

Name of Works: **SERVICE CONTRACT FOR PREPARATION OF SAMPLES USING EDM (ELECTRIC DISCHARGE MACHINING) PROCESS FOR BHEL -TRICHY DURING 2019-20**

Enquiry No.: **BHEL-TRY/ WCM/9471900057 / 17.05.2019**

BHARAT HEAVY ELECTRICALS LIMITED

TIRUCHIRAPPALLI-620 014

WORKS CONTRACTS MANAGEMENT

NOTICE INVITING TENDER

| | | | | | | | | | | | | | | | | | | | | | | | | | | |
|--|--|--|---------------------------------------|---------------------|--|----|--|----|--|----|--|----|---------------------------------------|----|---|----|--|----|--------------------------|----|--|----|-------------------------------------|---------------------|-----------------------|----|
| 1. | Tender Ref No: | BHEL-TRY/ WCM/9471900057 / 17.05.2019 | | | | | | | | | | | | | | | | | | | | | | | | |
| 2. | Tender Type | Open Tender -Two part | | | | | | | | | | | | | | | | | | | | | | | | |
| 3. | Name of works | SERVICE CONTRACT FOR PREPARATION OF SAMPLES USING EDM (ELECTRIC DISCHARGE MACHINING) PROCESS FOR BHEL -TRICHY DURING 2019-20. | | | | | | | | | | | | | | | | | | | | | | | | |
| 4. | Location of work | VENDOR'S WORKS | | | | | | | | | | | | | | | | | | | | | | | | |
| 5. | Period of contract | Twelve months from the date of award of contract. | | | | | | | | | | | | | | | | | | | | | | | | |
| 6. | Earnest Money Deposit Amount | ₹ 23,490/- (Rupees Twenty three thousand four hundred and ninety only) | | | | | | | | | | | | | | | | | | | | | | | | |
| 7. | Contents of Tender Document. | <table border="0"> <tr> <td>A] Part-I <u>Technical Bid</u></td> <td style="text-align: right;"><u>Pages</u></td> </tr> <tr> <td>ANNEX-1A (Technical Bid-Qualifying Criteria)</td> <td style="text-align: right;">03</td> </tr> <tr> <td>ANNEX -1B (Scope of Work & Technical Terms and Conditions)</td> <td style="text-align: right;">10</td> </tr> <tr> <td>ANNEX -1C (General Terms & Conditions of Contract)</td> <td style="text-align: right;">10</td> </tr> <tr> <td>ANNEX -1D (Special Terms & Conditions of Contract)</td> <td style="text-align: right;">02</td> </tr> <tr> <td>ANNEX - A (No deviation certificate)</td> <td style="text-align: right;">01</td> </tr> <tr> <td>ANNEX –B (EMD payment Instruction E-COLLECT)</td> <td style="text-align: right;">01</td> </tr> <tr> <td>ANNEX –C (Tender Opening authorization letter)</td> <td style="text-align: right;">01</td> </tr> <tr> <td>ANNEX - D (EFT Format)</td> <td style="text-align: right;">01</td> </tr> <tr> <td>ANNEX - E (CA Certificate for MSE Bidder)</td> <td style="text-align: right;">01</td> </tr> <tr> <td>B] Part- II <u>Price Bid</u></td> <td style="text-align: right;"><u>Pages</u></td> </tr> <tr> <td>ANNEX –II (Price bid)</td> <td style="text-align: right;">02</td> </tr> </table> | A] Part-I <u>Technical Bid</u> | <u>Pages</u> | ANNEX-1A (Technical Bid-Qualifying Criteria) | 03 | ANNEX -1B (Scope of Work & Technical Terms and Conditions) | 10 | ANNEX -1C (General Terms & Conditions of Contract) | 10 | ANNEX -1D (Special Terms & Conditions of Contract) | 02 | ANNEX - A (No deviation certificate) | 01 | ANNEX –B (EMD payment Instruction E-COLLECT) | 01 | ANNEX –C (Tender Opening authorization letter) | 01 | ANNEX - D (EFT Format) | 01 | ANNEX - E (CA Certificate for MSE Bidder) | 01 | B] Part- II <u>Price Bid</u> | <u>Pages</u> | ANNEX –II (Price bid) | 02 |
| A] Part-I <u>Technical Bid</u> | <u>Pages</u> | | | | | | | | | | | | | | | | | | | | | | | | | |
| ANNEX-1A (Technical Bid-Qualifying Criteria) | 03 | | | | | | | | | | | | | | | | | | | | | | | | | |
| ANNEX -1B (Scope of Work & Technical Terms and Conditions) | 10 | | | | | | | | | | | | | | | | | | | | | | | | | |
| ANNEX -1C (General Terms & Conditions of Contract) | 10 | | | | | | | | | | | | | | | | | | | | | | | | | |
| ANNEX -1D (Special Terms & Conditions of Contract) | 02 | | | | | | | | | | | | | | | | | | | | | | | | | |
| ANNEX - A (No deviation certificate) | 01 | | | | | | | | | | | | | | | | | | | | | | | | | |
| ANNEX –B (EMD payment Instruction E-COLLECT) | 01 | | | | | | | | | | | | | | | | | | | | | | | | | |
| ANNEX –C (Tender Opening authorization letter) | 01 | | | | | | | | | | | | | | | | | | | | | | | | | |
| ANNEX - D (EFT Format) | 01 | | | | | | | | | | | | | | | | | | | | | | | | | |
| ANNEX - E (CA Certificate for MSE Bidder) | 01 | | | | | | | | | | | | | | | | | | | | | | | | | |
| B] Part- II <u>Price Bid</u> | <u>Pages</u> | | | | | | | | | | | | | | | | | | | | | | | | | |
| ANNEX –II (Price bid) | 02 | | | | | | | | | | | | | | | | | | | | | | | | | |
| 8. | Address for submission of offer | <p>PHILIP P G, SM / WCM Works Contracts Management (WCM) Building 53, First Floor, BHEL, High Pressure Boiler Plant, Trichy - 620 014</p> <p>Note: The offer may be submitted in person by dropping the same in tender box kept at above mentioned address.</p> | | | | | | | | | | | | | | | | | | | | | | | | |
| 9. | Contact details for queries related to tender | <p>Satya Prakash, Dy. Manager / WCM; 0431 257 5242; e-mail: satyaprakash@bhel.in</p> <p>Philip P G, SM/ WCM; 0431 257 1913; e-mail: philip@bhel.in</p> | | | | | | | | | | | | | | | | | | | | | | | | |
| 10. | Contact details for queries related to scope of work | <p>Dhanesh Kant Verma, Manager / WRI e-mail : dkverma@bhel.in / Ph: 0431 257 7278</p> | | | | | | | | | | | | | | | | | | | | | | | | |
| 11. | Due date for submission of offer | 08.06.2019/ 10:00 Hrs. | | | | | | | | | | | | | | | | | | | | | | | | |
| 12. | Due date for opening of Techno -Commercial Bid | 08.06.2019/ 10:30 Hrs. | | | | | | | | | | | | | | | | | | | | | | | | |

Name of Works: **SERVICE CONTRACT FOR PREPARATION OF SAMPLES USING EDM (ELECTRIC DISCHARGE MACHINING) PROCESS FOR BHEL -TRICHY DURING 2019-20**

Enquiry No.: **BHEL-TRY/ WCM/9471900057 / 17.05.2019**

INSTRUCTIONS TO THE TENDERERS

The Tender addressed to SM/WCM, Works Contracts Management, 53 Building, BHEL, Tiruchirappalli 620 014 should reach WCM on or before **10:00 Hrs. 08.06.2019** or the same may be dropped in the Tender box kept at Works Contracts Management, 53 Building, BHEL, Tiruchirappalli 620 014. Tenders will be opened by **10:30 Hrs. (IST) on 08.06.2019** at Works Contracts Management, 53 Building, BHEL, Tiruchirappalli 620 014.

The tender document consists of following: (1) Part-I: Earnest money deposit (EMD) amount, (2) Part-I: Techno-Commercial bid & (3) Part-II: (Price bid)

Bidder shall submit the offer in following manner:

1. The first envelope shall contain EMD related documents and super scribed as EMD Cover for NIT / Tender Ref Number and Name of the work.

2. The second envelope shall contain Part-I (Technical bid documents shall sign on all the copies and affix vendor's seal) and shall be sealed and super scribed as Part-I (Technical Bid for NIT/Enquiry No.)

3. The third envelope shall contain only Part-II (Price bid) for the above work as per scope and to be quoted as per the format given in price bid. Any other information in price bid will not be considered. The envelope shall be sealed and super scribed as Price Bid for NIT / Enquiry No.

All the above **three envelopes** shall be kept into one cover, sealed and super scribed as Tender Document for the work as per NIT (NIT/Enquiry No).

The Tender (Envelope containing Part I & II along with supporting documents) should reach WCM on or before the due date and time.

Mode of receipt of offer shall be registered post/ by hand /e-mail /speed post / courier etc.

Checklist for submission of offer has been provided to ensure that tender submitted is complete in all respect. The checklist shall be properly filled and submitted along with the offer.

Check list for submission of offer

| Sl. No | Description | Remarks |
|--------|---|---|
| 1 | Separate Part-I: EMD cover containing Earnest Money Deposit amount of ₹ 23,490/- and superscribed with Tender reference number and Name of work. | <input type="checkbox"/> Enclosed / <input type="checkbox"/> Not enclosed |
| | a. EMD may be submitted in the form of Cash deposit (Before tender opening) / Bankers Cheque / Pay order / DD / FDR drawn in favor of BHEL, Trichy (Along with offer)/ EFT payment details vide SBI Collect as EMD (Before tender opening). b. EMD is waived off based on submission of UAM along with CA Certificate (As per Annexure-I of tender document) issued for latest financial year ending on 31st March 2018 or later / Valid EM-II with deemed validity of five years from the date of issue of EM-II as on date of technical bid opening / EM-II along with latest CA certificate (As per Annexure-I of tender document) issued for latest financial year ending on 31st March 2018 or later where deemed validity of five years is expired / Valid NSIC Registration Certificate as on date of technical bid opening / Valid Registration to any other body as specified by ministry of MSME. EMD in any other form (One Time EMD, BG for full amount of EMD etc.) is not acceptable. | |

Name of Works: **SERVICE CONTRACT FOR PREPARATION OF SAMPLES USING EDM (ELECTRIC DISCHARGE MACHINING) PROCESS FOR BHEL -TRICHY DURING 2019-20**

Enquiry No.: **BHEL-TRY/ WCM/9471900057 / 17.05.2019**

| Sl. No | Description | Remarks |
|--------|---|---|
| 2 | Separate Part-I: Technical Bid cover (superscribed with Tender reference number and Name of work) containing duly filled, signed and stamped copy of tender document along with following supporting documents to meet the pre-qualification criteria. | <input type="checkbox"/> Enclosed / <input type="checkbox"/> Not enclosed |
| 2.1 | Duly signed and stamped copy of documentary evidence in support of Status of the Enterprise/ Company/ Firm as indicated in pre-qualification criteria. | <input type="checkbox"/> Enclosed / <input type="checkbox"/> Not enclosed |
| 2.2 | Duly signed and stamped copy of documentary evidence for Minimum one year of experience of execution of works as per scope of work or works related to machining using EDM technique executed after 31st March, 2011 as per C: "Pre- qualification Criteria: Technical competency "of technical bid. | <input type="checkbox"/> Enclosed / <input type="checkbox"/> Not Enclosed |
| 2.3 | Duly signed and stamped copy of Income Tax Registration (PAN) | <input type="checkbox"/> Enclosed / <input type="checkbox"/> Not enclosed |
| 2.4 | Duly signed and stamped copy of Goods and Service Tax (GST) Registration Document | <input type="checkbox"/> Enclosed / <input type="checkbox"/> Not enclosed |
| 2.5 | Duly signed and Sealed copy of " No deviation certificate " in letterhead as per enclosed Annexure-A of tender document | <input type="checkbox"/> Enclosed / <input type="checkbox"/> Not enclosed |
| 3 | Separate Part-II (Price Bid) cover (superscribed with Tender reference number and Name of work) duly filled, signed and stamped. | <input type="checkbox"/> Enclosed / <input type="checkbox"/> Not enclosed |
| 9 | All the above documents / covers kept in separate Envelope and superscribed with Tender reference number and Name of work | <input type="checkbox"/> Enclosed / <input type="checkbox"/> Not enclosed |

Note: Bidders are requested to submit documents to meet the pre-qualification criteria of tender only. Additional documents not relevant to tender pre-qualification criteria / tender need not be enclosed along with the offer

Name of Works: **SERVICE CONTRACT FOR PREPARATION OF SAMPLES USING EDM (ELECTRIC DISCHARGE MACHINING) PROCESS FOR BHEL -TRICHY DURING 2019-20.**

Enquiry No.: **BHEL-TRY/ WCM/9471900057 / 17.05.2019**

IMPORTANT POINTS TO BE TAKEN CARE OF WHILE SUBMITTING OFFER.

- (a) Should a Tenderer find discrepancies or omissions in the Tender documents or should there any doubt as to their meaning, he should at once address the authority inviting the Tender, for clarification well before the due date, so as to submit his Tender in time. (No extension of time shall be given for submission of the Tender on any account)
- (b) Conditional and late Tenders, Tenders containing prima-facie absurd rates and amounts, Tenders which are incomplete or otherwise considered defective and Tenders not in accordance with the Tender conditions herein contained and the Tenders not in original **ARE LIABLE TO BE REJECTED**
- (c) New vendors responding against BHEL web site / NIC / CPPP, may visit the area of work, if they want, to know the scope / work details and also area of work, prior to quoting.
- (d) All pages of the tender document and supporting documents shall be dully signed, stamped and Submitted along with the offer as token of acceptance.
- (e) Documents not signed and stamped by the authorized signatory of the bidder shall not be accepted and considered for evaluation of bid.
- (f) Any additional documents submitted by the bidder during processing of the tender shall not be accepted unless it is dully signed, stamped even if the documents are received in soft form.
- (g) All entries in the Tender documents should be in one ink. Erasures and overwriting are not permitted. All cancellations and insertions should be duly attested by the Tenderers concerned.
- (h) Bidder has to quote as per the Work / Rate schedule. Price bid quoting in any other form will not be accepted and will be rejected.
- (i) Bidder has to quote in figures as well as in words for all the items shown in the attached schedule. Wherever there is a difference in the two, the rates quoted in words will be taken as final.
- (j) The Tender must be signed separately and legibly by Partner / Director of the Firm or by the person holding the Power of Attorney on behalf of the Firm concerned. In the latter case, a copy of Power of Attorney, duly self-attested must be accompanied.
- (k) If a Tenderer deliberately gives wrong information in his Tender or creates conditions favorable for the acceptance of his Tender, the BHEL will REJECT SUCH TENDER AT ANY STAGE.
- (l) Words imparting singular number shall be deemed to include plural number and vice-versa where the context so requires.
- (m) Canvassing in any form in connection with Tenders is strictly prohibited and the Tenders submitted by the Contractors who resort to canvassing will be liable for rejection.
- (n) Should a Tenderer's or a Contractor's or in the case of a firm or company of Contractors / any of its Directors / Managing partner's / Managing director and there elative is employed in BHEL, the authority inviting the Tenders shall be informed in writing of this fact at the time of submission of the Tender, failing which the Tender may be disqualified, or if such fact subsequently comes to light, the Contract may be cancelled.
- (o) The Tender schedule and the Tender shall be deemed to form an integral part of the Contract to be entered into for this work.
- (p) Submission of Tenders by electronic media like e-mail, Internet, fax etc. followed by hard copy, is acceptable and will be at the sole risk of the Tenderer. The Tenders thus submitted will be final and binding on the Tenderer. BHEL will not be responsible for any consequences that may arise in this regard.
- (q) Late and Delayed Tenders will be summarily rejected and under no circumstances it will be considered and accepted.

Name of Works: **SERVICE CONTRACT FOR PREPARATION OF SAMPLES USING EDM (ELECTRIC DISCHARGE MACHINING) PROCESS FOR BHEL -TRICHY DURING 2019-20.**

Enquiry No.: **BHEL-TRY/ WCM/9471900057 / 17.05.2019**

- (r) **Offer without EMD / supporting documents to avail waiver of EMD in separate Cover will be summarily rejected.**
- (s) The contractor must satisfy himself by personal study and examination of the specifications furnished and understand thoroughly the scope of proposed work in detail and all conditions affecting the work before entering into the contract.
- (t) Tenderers shall pursue carefully the instructions and directions to parties in tendering and the conditions of the agreement and all other relevant documents before tendering the rates for the work. The approximate quantity of work to be executed under each clause is given in the schedule. The quantities are given with a view to enable tenderer to quote his overall rate for each class of work in the tender form and for a uniform comparison of tenders. It shall be definitely understood that BHEL does not accept any responsibilities for the correctness or completeness of this schedule and the schedule is liable to alternations by omissions, deductions or additions at the discretion of accepting authority. In case of any doubts/clarifications, he is advised to approach BHEL-Trichy before tender submission.
- (u) Before quoting rates for the work, the tenderer shall inspect the site of work, and should satisfy himself about the nature and scope of work to be executed. BHEL will not, however, after acceptance of a contract rate, pay extra charges for any other reason. In case the contractor is found later on to have misjudged the nature and scope of the work and also the availability of materials, no separate scheme will be provided for estimation.

NOTE

- *BHEL may reject the bid or in case the contract has been awarded, terminate the contract apart from taking any other suitable action under the contract or applicable legal provisions or BHEL guidelines including Guidelines for suspension of Business Dealings, without any liability for any compensation to the bidder if, BHEL discovers at any time that any statement made by the bidder in the affidavit cum undertaking is false, fraudulent*
 - Or
 - Any document submitted by the bidder was fake and forged*
 - Or
 - If BHEL determines in the sole discretion that any statement was aimed at deliberately misleading BHEL with a view to ensure award of the subject contract to the bidder.*
- *The quoted rate shall be valid up to **six months** from date of Tender opening.*
- *The rates shall **remain firm** for the entire period of the contract in case WO is awarded*
- *Income Tax deduction at source as applicable in the IT Act from time to time will be made on the value of the bills in the absence of Income Tax Exemption Certificate from the concerned IT officer.*
- *If the Contractor back outs after opening of tender, the contractor is liable for forfeiture of the EMD paid.*
- *In case contract is not executed by vendor after award and acceptance of contract, BHEL may exercise the right to forfeit EMD, Security Deposit / BG of such contractors and also suitable action will be taken by BHEL on those Contractors as deemed fit.*
- ***BHEL does not guarantee any minimum quantity against the subject tender.***
- ***EMD of successful bidder shall be converted to / adjusted against Security Deposit.***

PART-I (TECHNO COMMERCIAL BID)

A: (Bidders Profile)

| | | |
|-----|--|--|
| 1. | Name of the Enterprise/ Company/ Firm. | |
| 2. | Name of Directors / Partners / proprietor of Enterprise/ Company/ Firm | |
| 3. | Registered Address of Enterprise/ Company/ Firm | |
| 4. | Contact Details : Landline /Mobile number:. | |
| 5. | E-mail Address for communication w.r.t tender / award of work. | |
| 6. | Name and Contact details of person for communication related to Tender | |
| 7. | BHEL Vendor Code (If any) | BHEL- Trichy Vendor Code: (If vendor code is not available, kindly Submit the original RTGS Format duly filled and signed as per Annexure-C along with cancelled cheque leaf) |
| 8. | PF Registration (As applicable) To be obtained before start of work if already not registered | () Registered () Not Registered PF Registration No: (Copy of registration to be attached) |
| 9. | ESI Registration (As applicable) To be obtained before start of work if already not registered | () Registered () Not Registered ESI Registration No: (Copy of registration to be attached) |
| 10. | Labour License (As applicable) To be obtained after award of work and before start of work | () Registered () Not Registered Labour License No: (Copy of Labour license to be attached) |
| 11. | MSME Status Documentary evidence to be enclosed to get the Benefit of MSE | <input type="checkbox"/> MSE Bidder / <input type="checkbox"/> Non MSE Bidder NSIC Registered certificate / Entrepreneur Memorandum Part – II (EM-II) along with CA certificate / MSE vendor having UAM certificate along with CA certificate (CA certificate format as per Annexure-I) |

NOTE:

If vendor fails to get PF / ESI /Labour License (As applicable) before start of work, EMD / SD shall be forfeited and penal action shall be taken as per Extant rules of BHEL.

Name of Works: **SERVICE CONTRACT FOR PREPARATION OF SAMPLES USING EDM (ELECTRIC DISCHARGE MACHINING) PROCESS FOR BHEL -TRICHY DURING 2019-20.**

Enquiry No.: **BHEL-TRY/ WCM/9471900057 / 17.05.2019**

B: Pre- qualification Criteria: Earnest Money Deposit (EMD) & status of firm

| | | |
|---|---|---|
| <p>1</p> | <p>EMD amount: ₹ 23,490/- (` Twenty three thousand four hundred and ninety only)</p> <p>EMD may be submitted in following ways:</p> <p>i) Electronic fund transfer credited in BHEL account (Before Tender Opening). (Refer Annexure -C for making EMD payment through SBI-E collect)</p> <p>ii) In the form of Cash deposit (Done before tender opening) / Bankers Cheque / Pay order / DD / FDR (Along with offer) drawn in favour of BHEL - Trichy, payable at Trichy issued by Scheduled Bank / Nationalized bank / Consortium banks.</p> <p>EMD in any other form (One Time EMD, BG for full value of EMD etc.) is not acceptable.</p> <p>EMD is waived off based on submission of UAM along with CA Certificate (As per Annexure-I of tender document) issued for latest financial year ending on 31st March 2018 or later / Valid EM-II with deemed validity of five years from the date of issue of EM-II as on date of technical bid opening / EM-II along with latest CA certificate (As per Annexure-I of tender document) issued for latest financial year ending on 31st March 2018 or later where deemed validity of five years is expired / Valid NSIC Registration Certificate as on date of technical bid opening / Valid Registration to any other body as specified by ministry of MSME.</p> | <p>DD/ FDR / PAY ORDER DETAILS: AMOUNT: ₹</p> <p>INST. NO:</p> <p>INST. DATE:</p> <p>ISSUING BANK:</p> <p style="text-align: center;">OR</p> <p>RTGS PAYMENT DETAILS: AMOUNT: ₹</p> <p>RECEIPT NO:</p> <p>RECEIPT DATE:</p> <p>BANK DETAILS:</p> <p style="text-align: center;">OR</p> <p>MSME / NSIC / SSI REG. DETAILS:</p> <p>REG.NO:</p> <p>REG. DATE:</p> <p>REG. CATEGORY: () MICRO / () SMALL</p> |
| <p>2.</p> | <p>Status of the Enterprise/ Company/ Firm.</p> | <p>Status:.....</p> <p>Reg. No:</p> <p>Reg. Date:</p> <p>(Vendor to provide the details and copy of document in support of above)</p> |
| <p>Following documents may be submitted based on status of Enterprise/ Company/ Firm.</p> | | |
| <p>2.1</p> | <p>Sole Proprietorship</p> | <p>Trade License / GST registration / Auditor's letter</p> |
| <p>2.2</p> | <p>Partnership</p> | <p>Registered Partnership Deed and (Trade License / GST registration)</p> |
| <p>2.3</p> | <p>Private Limited Company / Public Limited Company / Public Sector / Govt. Org</p> | <p>Certificate of Registration/Memorandum of Association & Articles of Association</p> |

Name of Works: **SERVICE CONTRACT FOR PREPARATION OF SAMPLES USING EDM (ELECTRIC DISCHARGE MACHINING) PROCESS FOR BHEL -TRICHY DURING 2019-20.**

Enquiry No.: **BHEL-TRY/ WCM/9471900057 / 17.05.2019**

C: Pre- qualification Criteria: Technical competency

| | |
|----------|---|
| 1 | Work Experience |
| 1 | <p>Minimum one year of experience of execution of works as per scope of work or works related to machining using EDM technique executed after 31st March, 2011.</p> <p>(Experience proof from BHEL shall contain work order copies and experience proof from other than BHEL shall contain work order / agreement copies along with Form 26AS / TDS certificate / bank statement for payment from the organisation for the work executed to be enclosed.)</p> |

D: Pre- qualification Criteria: Statutory requirements & acceptance to Tender terms & conditions

| | | |
|----------|--|---|
| 1 | Income Tax Registration (PAN) (Documentary evidence to be enclosed) | PAN: Self-attested copy of Income Tax Registration <input type="checkbox"/> Enclosed / <input type="checkbox"/> Not enclosed |
| 2 | Goods and Service Tax (GST) Registration (If any specific exemption is available, a declaration with due supporting documents need to be furnished for considering the offer) | GST No: Self-attested copy of Goods and Service Tax (GST)Registration <input type="checkbox"/> Enclosed / <input type="checkbox"/> Not enclosed / <input type="checkbox"/> Exempted |
| 3 | Duly signed and Sealed copy of "No deviation certificate" in letterhead as per enclosed Annexure-A of tender document in Enterprise/ Company/ Firm letterhead. | <input type="checkbox"/> Enclosed / <input type="checkbox"/> Not enclosed |
| 4 | Declaration regarding quoting for all items / schedules as per BOQ / Price bid. | Quoted for all items / schedules as per BOQ / Price bid () Quoted () Not -Quoted |
| 5 | Applicable GST % against the scope of work | _____% GST (Vendor to confirm) |

NOTE: Self attested copy of all the documents should be submitted along with Tender, if at any stage, the document(s) submitted by Contractor is / are found incorrect / false / fake, the necessary action will be taken by BHEL against Contractor viz., legal, Contractual, BHEL Policy / Procedural Actions in whatsoever manner as deemed fit.

The bidder shall sign on all the copies of technical bid and affix his seal

PART-I (TECHNO COMMERCIAL BID)

SCOPE OF WORK AND TECHNICAL TERMS & CONDITIONS

A. BILL OF QUANTITY

| SL NO | Description of Work | UOM | Approx. Quantity |
|-------|--|-----|------------------|
| 1 | Preparation of Impact sample as per scope of work. | No | 150 |
| 2 | Preparation of Tensile sample (round) as per scope of work. | No | 100 |
| 3 | Preparation of Tensile sample (flat) as per scope of work. | No | 50 |
| 4 | Preparation of Hot tensile (gleeble) sample as per scope of work. | No | 100 |
| 5 | Preparation of Hot compression (gleeble) as per scope of work. | No | 100 |
| 6 | Preparation of Vare-straint sample as per scope of work. | No | 75 |
| 7 | Preparation of CCT sample (gleeble) as per scope of work. | No | 75 |
| 8 | Preparation of stress corrosion sample as per scope of work. | No | 50 |
| 9 | Preparation of Flat blanks sample as per scope of work. | No | 100 |
| 10 | Preparation of V notch for CTOD samples by EDM as per scope of work. | No | 50 |
| 11 | Preparation of Pellini drop weight samples-Machining as per scope of work. | No | 25 |
| 12 | Preparation of Pellini drop weight samples-Notch cutting on hard faced deposition as per scope of work. | No | 50 |
| 13 | Preparation of Ultrasonic reference block sample as per scope of work. | No | 5 |

B. Scope of Work .

1. The scope of work includes extraction of blanks (finished or semi-finished products) to the dimension required for machining of given materials as per the drawing using EDM.
2. The samples should be start and made exactly from the location as specified in the drawing.
3. Semi-finished blanks to be machined to the given dimensions by means of conventional machining process (milling, turning, thread making, drilling, etc.)
4. After machining, the components shall be deburred to remove burr, sharp corners etc.
5. The finished specimens shall have no machining marks and the surface finish should strictly match with the drawing specification.
6. Vendor shall arrange transportation of raw material and finished components from and to WRI. All the expenses related to transportation of material will be borne by the vendor only.
7. Vendor shall maintain the records, preserve the scrap and return it to WRI along with finished goods, with proper identification.
8. Final quality inspection to be carried out at the time of returning the test samples.
9. The completed sample/ components in each lot will be inspected for dimensional accuracy, surface finish, etc. at WRI.
10. Materials will be issued in the lot basis for machining, a lot will be considered as minimum of 5% of the total order value OR depends upon the work load.
11. Vendor must have the EDM facility in his own premises.
12. Vendor must have the trained EDM operator in his own premises.
13. Vendor may be asked to call for a visit by WRI person to confirm the availability of EDM facility and trained EDM operator.

Name of Works: **SERVICE CONTRACT FOR PREPARATION OF SAMPLES USING EDM (ELECTRIC DISCHARGE MACHINING) PROCESS FOR BHEL -TRICHY DURING 2019-20.**

Enquiry No.: **BHEL-TRY/ WCM/9471900057 / 17.05.2019**

Raw material:

| | Material | Length | OD | ID | Thickness | WELDED PIPE SAMPLE |
|-------------|-------------|--------|-----|-----|-----------|--|
| WELDED PIPE | Inconel 617 | 500 | 524 | 250 | 137 |  |
| | Inconel 617 | 500 | 402 | 250 | 76 | |
| | Inconel 617 | 500 | 619 | 315 | 152 | |
| | Inconel 617 | 500 | 505 | 315 | 95 | |
| | Inconel 617 | 500 | 686 | 610 | 38 | |
| | Inconel 617 | 500 | 824 | 550 | 137 | |
| | Inconel 625 | 500 | 620 | 320 | 150 | |
| | Material | Length | OD | ID | Thickness | BASE PIPE SAMPLE |
| BASE PIPE | Inconel 617 | 500 | 524 | 250 | 137 |  |
| | Inconel 617 | 500 | 402 | 250 | 76 | |
| | Inconel 617 | 500 | 619 | 315 | 152 | |
| | Inconel 617 | 500 | 505 | 315 | 95 | |
| | Inconel 617 | 500 | 686 | 610 | 38 | |
| | Inconel 617 | 500 | 824 | 550 | 137 | |
| | Inconel 625 | 500 | 620 | 320 | 150 | |

- Raw materials are generally high strength ferritic materials and non-magnetic Ni-rich austenitic materials with strong work hardening characteristics, and it requires proper facilities for cutting and machining like EDM, CNC milling/turning, surface grinding with proper tooling
- These may be in the form of plate, tube, pipes and components with various dimensions supplied in the conditions of as-cast, hardened, and as-welded condition.
- The required sample drawings will be issued along with issue of raw materials.

Details of Raw materials and their forms: PIPE



TUBE

| Material | Length | OD | ID | Thickness |
|-------------|--------|-------|-------|-----------|
| Inconel 617 | 200 | 44.5 | 29.3 | 7.6 |
| Inconel 617 | 200 | 50.8 | 28.4 | 11.2 |
| Inconel 617 | 200 | 52 | 21.6 | 15.2 |
| Inconel 617 | 200 | 69.85 | 57.05 | 6.4 |
| Inconel 617 | 200 | 63.5 | 50.5 | 6.5 |
| Inconel 617 | 200 | 76.2 | 61 | 7.6 |
| Inconel 617 | 200 | 52 | 33 | 9.5 |

PLATE

| | Material | Length | Width | Thickness |
|---------------------------|--------------|--------|-------|-----------|
| WELDED PLATE | Inconel 625 | 400 | 400 | 40 |
| | Inconel 740H | 400 | 400 | 40 |
| | Inconel 617 | 400 | 400 | 25 |
| | Inconel 617 | 400 | 400 | 40 |
| | Inconel 617 | 400 | 400 | 65 |
| | Material | Length | Width | Thickness |
| BASE PLATE Inconel 617 | Inconel 617 | 250 | 250 | 25 |
| | Inconel 617 | 250 | 250 | 40 |
| | Inconel 617 | 250 | 250 | 65 |

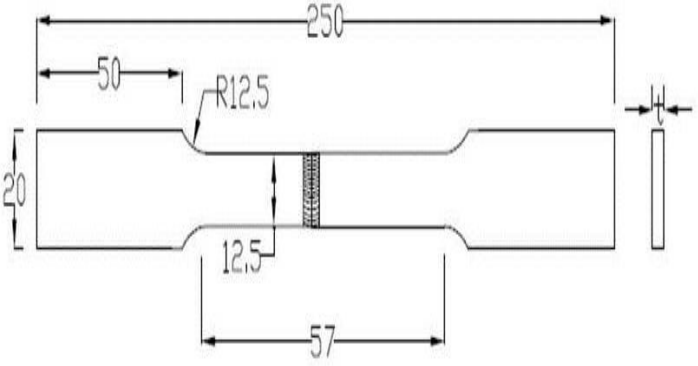
| Details of drawing for sample | | | | |
|-------------------------------|------------------------|--|---|-------|
| S.No. | Name | Raw Material condition | Drawings | Image |
| 1 | Impact Sample | Pipe,tube & Plate (Welded or Base metal) | | |
| 2 | Tensile Sample (round) | Pipe,tube & Plate (Welded or Base metal) | <p>FIG. 6 TENSION TEST SPECIMEN</p> <p>G = GAUGE LENGTH</p> | |

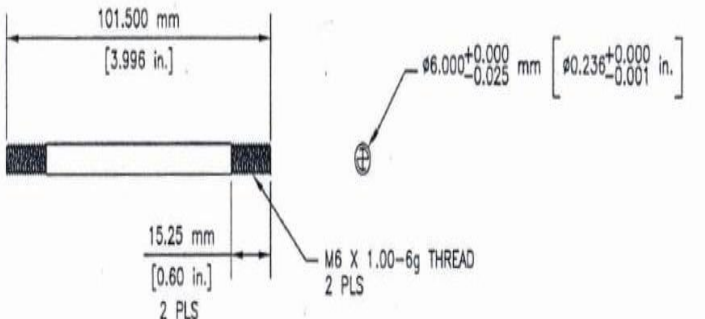
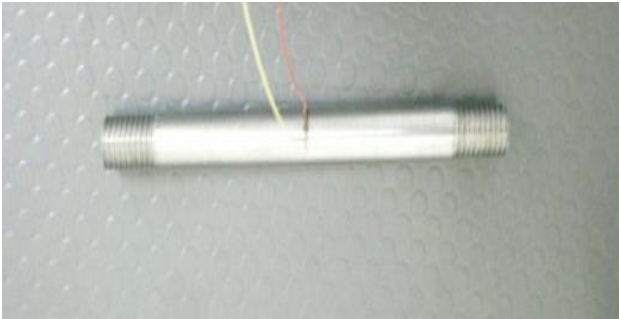
| | | | | |
|----------|------------------------------|---|---|--|
| <p>3</p> | <p>Tensile Sample (flat)</p> | <p>Pipe,tube & Plate (Welded or Base metal)</p> |  |  |
| <p>4</p> | <p>Hot Tensile (Gleeble)</p> | <p>Pipe,tube & Plate (Welded or Base metal)</p> |  |  |

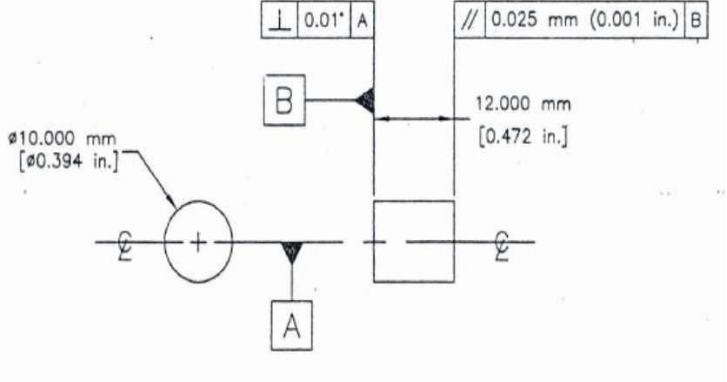
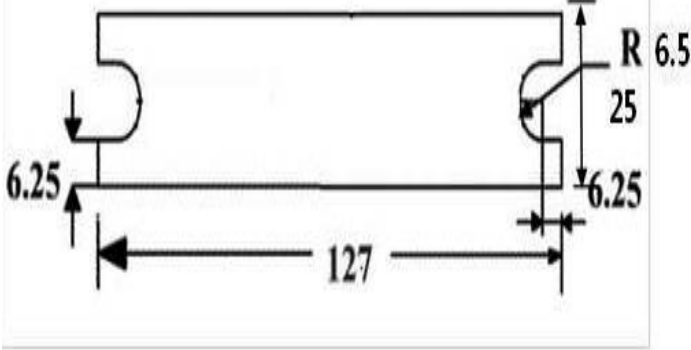
| | | | | |
|---|---------------------------|--|--|--|
| 5 | Hot compression (Gleeble) | Pipe,tube & Plate (Welded or Base metal) |  | |
| 6 | vare-Straint | Pipe,tube & Plate (Welded or Base metal) |  <p>All dimension are in mm. Uniform thickness is 3mm</p> | |

| | | | | |
|----------|--|---|---|--|
| <p>7</p> | <p>CCT sample (Gleeble)</p> | <p>Pipe,tube & Plate (Welded or Base metal)</p> | | |
| <p>8</p> | <p>Stress Corrosion sample</p> | <p>Pipe,tube & Plate (Welded or Base metal)</p> | <p>NOTE: ALL DIMENSIONS SHOWN IN MILLIMETERS.</p> | |

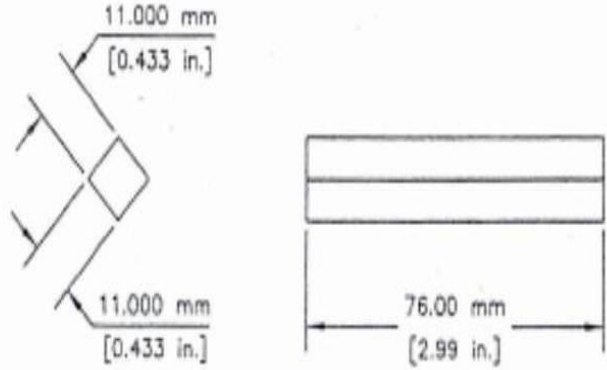
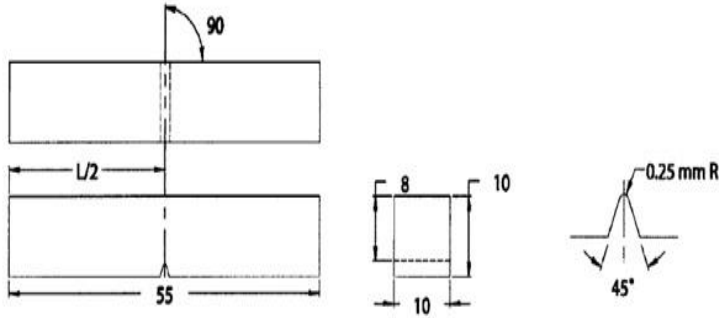
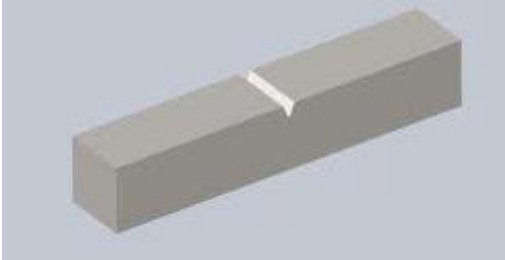
| | | | | |
|-----------|---------------------------|---|--|--|
| <p>9</p> | <p>Flat blanks</p> | <p>Pipe,tube & Plate (Welded or Base metal)</p> |  | |
| <p>10</p> | <p>"V" Notch Specimen</p> | <p>Pipe,tube & Plate (Welded or Base metal)</p> | <p>IMPACT SPECIMEN (ASTM E 23)</p>  |  |

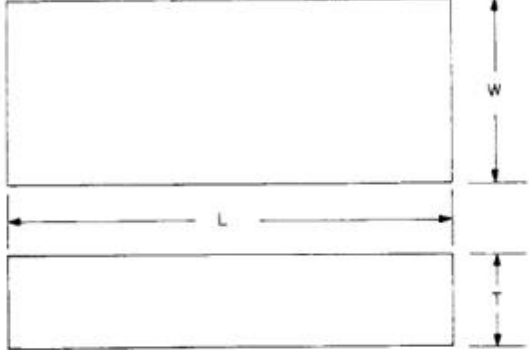
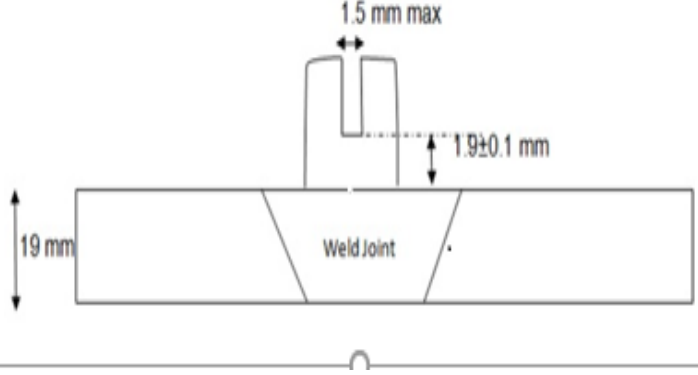
| <p>11</p> | <p>Pellini Drop Weight Sample</p> | <p>Plate</p> | <p>DROP WEIGHT SPECIMEN</p>  <table border="1" data-bbox="705 598 1220 774"> <thead> <tr> <th rowspan="2">Dimension</th> <th rowspan="2">Units</th> <th>Dimension</th> <th>Tolerance</th> </tr> </thead> <tbody> <tr> <td>T, Thickness</td> <td>in. 0.75 mm 19</td> <td>±0.04 ±1.0</td> </tr> <tr> <td>L, Length</td> <td>in. 5.0 mm 130</td> <td>±0.5 ±10</td> </tr> <tr> <td>W, Width</td> <td>in. 2.0 mm 50</td> <td>±0.04 ±1.0</td> </tr> </tbody> </table> | Dimension | Units | Dimension | Tolerance | T, Thickness | in. 0.75 mm 19 | ±0.04 ±1.0 | L, Length | in. 5.0 mm 130 | ±0.5 ±10 | W, Width | in. 2.0 mm 50 | ±0.04 ±1.0 | |
|-----------|--|---------------|--|---------------|-------|-----------|-----------|--------------|-------------------|---------------|-----------|-------------------|-------------|----------|------------------|---------------|--|
| Dimension | Units | Dimension | Tolerance | | | | | | | | | | | | | | |
| | | T, Thickness | in. 0.75 mm 19 | ±0.04 ±1.0 | | | | | | | | | | | | | |
| L, Length | in. 5.0 mm 130 | ±0.5 ±10 | | | | | | | | | | | | | | | |
| W, Width | in. 2.0 mm 50 | ±0.04 ±1.0 | | | | | | | | | | | | | | | |
| <p>12</p> | <p>Pellini Drop Weight Sample Notch making</p> | <p>Weld</p> |  | | | | | | | | | | | | | | |

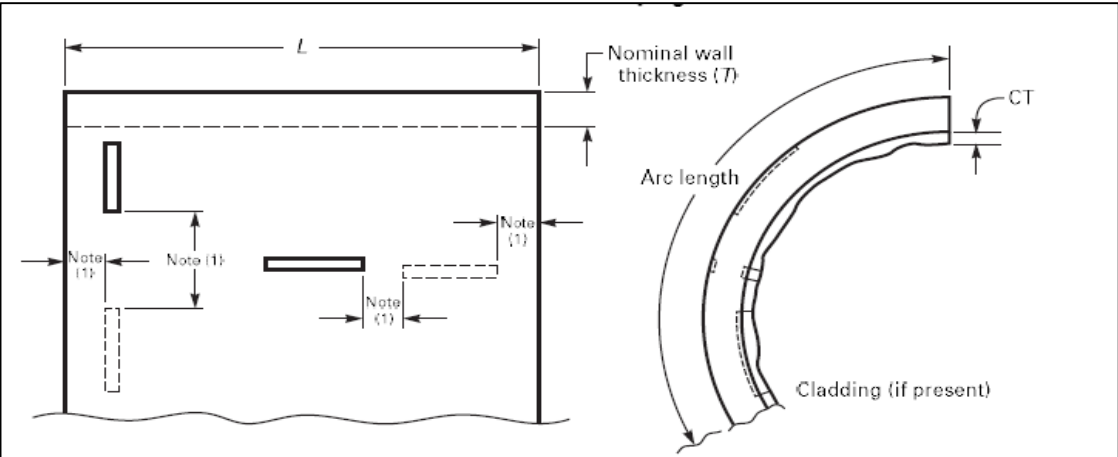
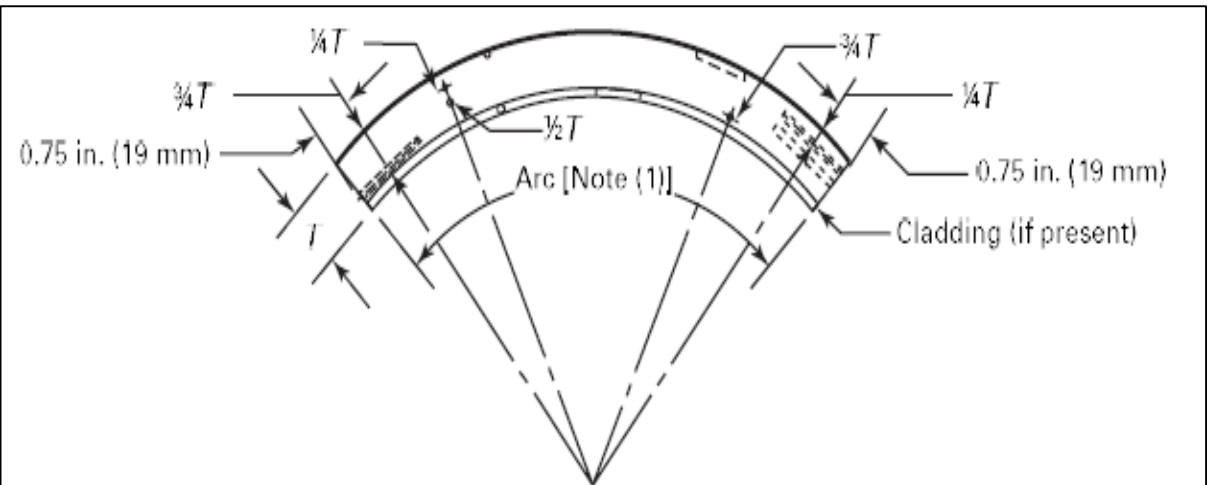
| | | | |
|----|-------------------|--------------------------------|---|
| 13 | Calibration Block | Both base metal and Weld metal |  <p>Technical drawing of a calibration block. The main view shows a rectangular block with length L and nominal wall thickness T. A detail view on the right shows a curved section with arc length and cladding (if present). The drawing includes several 'Note (1)' callouts pointing to specific features.</p> |
| | | |  <p>Detailed technical drawing of a curved section. It shows a semi-circular arc with various thickness dimensions: $\frac{1}{4}T$, $\frac{1}{2}T$, and $\frac{3}{4}T$. A dimension of 0.75 in. (19 mm) is indicated. The drawing also shows 'Arc [Note (1)]' and 'Cladding (if present)'.</p> |

C. CONTRACT PERIOD AND PLACE OF WORK:

1. **Duration of the contract:** Twelve months from the date of award of contract.

2. Delivery Schedule:

- a) Vendor has to collect the material within two days of intimation by WRI.
- b) The total lot has to be completed within 15 days from the date of collection of materials. In case of vendor failing to meet the time schedule without intimation, WRI reserves the right to invoke LD clause for the losses incurred due to not meeting the target

3. Place of work:

The work shall be carried out at vendor's work.

D. LIQUIDATED DAMAGES (LD)/PENALTY:

If the contractor fails to complete the service/work as per terms & conditions of the order within the delivery schedule, the following penalties/LD will be levied:

- a) Penalty @ 0.5 % of order value per week of delay in execution of work as per delivery schedule (Collection of sample within two days of intimation and completion of work for one lot within 15 days from the date of collection of materials) of scope of work or part thereof.
- b) Final quality inspection to be carried out at the time of returning the test samples, if the rejection level is more than 5% in the given lot, the total amount of the rejected sample or Rs. 500, whichever is higher, shall be deducted from the party's payment.
- c) The total value of Penalty / LD under clause a and b mentioned above shall be limited to maximum of 10 % of total order value.
- d) In case of any amendment / revision, Penalty shall be linked to the amended / revised PO value.

E. PAYMENT TERMS:

1. Payment will be made after completion of work on pro-rata basis based on actual number of samples machined as per scope of work after acceptance and certification of Area in charge (BHEL Executive).
2. The Contractor shall submit the bill within a week after at the end of each month in triplicate copies detailing the various items of work done during the month supported by the requisitions issued from time to time.
3. Any other relevant document which is required from time to time as per BHEL requirement.
4. The Contractor shall, once in every month, submit to the respective area HOD separately details of their claims for the work done by them up to and including the previous. He should in addition furnish a clear certificate to the effect that the claims submitted by him as aforesaid cover all his claims and that no further claims shall be raised by him in respect of the work done up to and including the period under report. Payment will be at the sole discretion of BHEL.
5. The proof of execution of work should be submitted along with each bill (printed form with covering letter and proof for execution of work). Payment will be made after 45 days from the date of bills Submission
6. If the Contractor is not registered for any statutory obligation and not liable thereto, then a declaration shall be submitted along with offer that they are within the threshold limit.
7. No advance may be paid for operational or any other expenses.
8. Goods and Services tax will be payable extra by BHEL at prevailing rates and corresponding TDS will be made as per Government norms.

PART-I (TECHNO COMMERCIAL BID)

ANNEXURE-IC

GENERAL TERMS & CONDITIONS OF CONTRACT

1. Definition:

In these General Conditions of Contract, the following terms shall have, I meaning hereby assigned to them, except where the context otherwise requires:

- a) The "Contract" means, the documents forming the tender and acceptance thereof, together with all the documents referred to therein including general and special conditions to contract. All these documents as applicable taken together shall be deemed to form one contract and shall be complementary to one another.
- b) The "Work" means, the work described in the tender documents in individual work orders as may be issued from time to time to the contractor by the Officer-In charge within the power conferred upon him including all notified or additional items of works and obligations to be carried out as required for the performance of contract.
- c) The "contractor" means, the individual Firm or Company whether incorporated or not, undertaking the work and shall include the legal personal representatives of such individuals or the persons composing the firm or Company or the successors of the firm or company and the permitted assigns of such individual or firm or Company.
- d) " The Officer-In charge" means, the Officer deputed by the BHEL to supervise the work or part of the work.
- e) "Approved" and "Directed" means, the approval or direction of the respective area **HOD** or person deputed by him for the particular purposes.
- f) "BHARAT HEAVY ELECTRICALS LIMITED" (hereinafter referred to as BHEL) shall mean the Board of Directors, Chairman, Executive Director, General Manager or, other Administrative Officer of the said Company including AGM / WCM authorised to invite tenders and enter into contract for works on behalf of the Company.
- g) The "Contract sum" means, the sum accepted or the sum calculated in accordance with the prices accepted in tender and / or the contract rates as payable to the contractor for the execution of the work during the currency of the contract.
- h) A "week" means, Seven Days, without regard to the number of hours worked or not worked in any day in that week.
- i) A "day" means, the day of 24 hours (TWENTY-FOUR) irrespective of the number of hours worked or not worked in that day.

2. Heading to the Contract Conditions:

The heading to these conditions shall not affect the interpretations thereof.

3. Deviations:

The contractor shall not carry out any work not covered by schedule except in pursuance of the written instructions of the respective area HOD/WCM. No such work shall be valid unless the same has been specifically confirmed and accepted by BHEL in writing and incorporated in the Contract.

4. Work to be carried Out:

The Contract shall include all labour which may be required for the execution of the work.

The Contractor will be deemed to have satisfied himself as to the nature of the site, local facilities of access and all matters affecting the execution of the work. No. extra charges consequent on any misunderstanding in these respects or otherwise will be allowed.

5. Assignment of Transfer of Contract:

The Contractor shall not, assign or transfer the contract or any part thereof, or any share, or interest thereon to any other persons.

Name of Works: **SERVICE CONTRACT FOR PREPARATION OF SAMPLES USING EDM (ELECTRIC DISCHARGE MACHINING) PROCESS FOR BHEL -TRICHY DURING 2019-20.**

Enquiry No.: **BHEL-TRY/ WCM/9471900057 / 17.05.2019**

6. Sub-Contract:

The Contractor shall not sublet any portion of the contract.

7. Compliance to Regulations and Bye-Laws:

The Contractor shall confirm to the provisions of any statute relating to the work and regulations and Bye-laws of any local authority. The Contractor shall be bound to give all notices required by statutory regulations or by-laws as aforesaid and to pay all fees and taxes payable to any authority in respect thereof.

8. Earnest Money Deposit (EMD) & Security Deposit (SD):

Earnest Money Deposit (EMD):

Tender must be accompanied by Earnest Money for the amount mentioned in tender notice, pledged to BHEL, Trichy in any of the forms mentioned below.

Modes of Deposit:

The EMD shall be accepted only in the following forms:

- a) Cash deposit as permissible under the extant Income Tax Act (before tender opening)
- b) Electronic Fund Transfer credited in BHEL account (before tender opening)
- c) Banker's cheque/ Pay order/ Demand draft, in favour of BHEL (along with offer)
- d) FDR issued by Scheduled Banks/ Public Financial Institutions as defined in the Companies Act (FDR should be in the name of the Contractor, a/c BHEL)
- e) In addition to the above, the EMD amount in excess of ₹ 2,00,000 /- (` two lakhs) also acceptable in the form of Bank guarantee from scheduled banks. The bank guarantee in such cases shall be valid for at least six months. (BG Format attached as Annexure-J)

Forfeiture of EMD:

EMD by the tenderer will be forfeited as per tender documents if

- i) After opening the Tender, the Tenderer revokes his Tender within the validity period or increase his earlier quoted rates.
- ii) If only, a part of the work included in the tender has been awarded to the tenderer and the tenderer refuses to take up the work the amount of Earnest Money to be forfeited will be based on the value of the contract so awarded.
- iii) The Tenderer does not commence the work within the period as per LOI / Contract. In case the LOI / Contract is silent in this regard then within 7 days after award of Contract.

General Terms related to EMD:

Earnest Money Deposit (EMD) will not carry any interest.

Earnest Money Deposit (EMD) of the successful tenderer will be retained as part of Security deposit.

The Earnest Money Deposit (EMD) will be refunded to the unsuccessful tenderers within 15 days of acceptance of the award of work by successful tenderer / expiry of offer validity period

Security Deposit (SD):

The contractor whose tender has been accepted shall, within seven days of receipt of the notification of acceptance of his tender, should deposit Security deposit @ 5 % of Contract value.

EMD of the successful tenderer shall be converted and adjusted towards the required amount of **Security deposit (SD):**

Modes of Deposit:

The balance amount to make up the required Security Deposit of 5% of the contract value may be accepted in the following forms:

- i) Cash (as permissible under the extant Income Tax Act)
- ii) Local cheques of Scheduled Banks (subject to realization)/ Pay Order/ Demand Draft/ Electronic Fund Transfer in favour of BHEL

Name of Works: **SERVICE CONTRACT FOR PREPARATION OF SAMPLES USING EDM (ELECTRIC DISCHARGE MACHINING) PROCESS FOR BHEL -TRICHY DURING 2019-20.**

Enquiry No.: **BHEL-TRY/ WCM/9471900057 / 17.05.2019**

iii) Bank Guarantee from Scheduled Banks/ Public Financial Institutions as defined in the Companies Act. The Bank Guarantee format should have the approval of BHEL

iv) Fixed Deposit Receipt issued by Scheduled Banks/ Public Financial Institutions as defined in the Companies Act (FDR should be in the name of the Contractor, a/c BHEL)

v) Securities available from Indian Post offices such as National Savings Certificates, Kisan Vikas Patras etc. (held in the name of Contractor furnishing the security and duly endorsed/ hypothecated/ pledged, as applicable, in favour of BHEL)

General Terms related to SD:

The security Deposit will not carry any interest.

Security Deposit shall be released to the contractor upon fulfilment of Contractual obligations as per terms of contract.

BHEL, shall not be responsible for any loss of securities due to liquidation or any other reason whatsoever or any depreciation in the value of the Securities while in their charge or for any loss of interest thereon.

NOTE: Acceptance of Security Deposit against Sl. No. (iii),(iv) and (v) above will be subject to hypothecation or endorsement on the documents (Signature of the Branch Manager must be present) in favor of BHEL. However, BHEL will not be liable or responsible in any manner for the collection of interest or renewal of the documents or in any other matter connected therewith.

All compensation or other sums of money payable by the contractor to BHEL under the terms of this contract or under any other contract with BHEL, may be deducted from the Security Deposit or realized by the sale of the securities or from the interest arising there from or from any sums which may be due or may become due to the contractor payable by BHEL, on any account whatsoever against this contract of any other contract with BHEL and in the event of his Security Deposit being reduced by reason of such deductions or sale as aforesaid, the Contractor shall within seven days thereafter make good in cash or in securities endorsed as aforesaid, any sum or sums by which the security Deposit has been so reduced.

In case of an Award of a Contract and if the Contractor fails to perform or does not comply with the Performance Evaluation Criteria, the Security Deposit will not be refunded / Bank Guarantee encashed.

The Bank Guarantee shall be kept valid until the due date for refund of Security Deposit.

Security Deposit has to be deposited within 7 days of LOI/WO. Else EMD will be forfeited and may also attract the provision of "Suspension of Business dealings with Suppliers/Contractors".

9. GOODS & SERVICE TAX (GST) REGISTRATION & COMPLIANCE

1. Supplier shall mention their GSTN registration number in all their invoices and invoices shall be in the format as specified/prescribed under GST laws. Invoices shall necessarily contain Invoice number (in case of multiple numbering system is being followed for billing like SAP invoice no, commercial invoice no etc., then the Invoice No which is linked/uploaded in GSTN network shall be clearly indicated), item description as per PO, Quantity, Rate, Value, applicable taxes with nomenclature (like IGST, SGST, CGST & UTGST) separately, HSN/ SAC Code, etc.
2. All invoices shall bear the HSN Code for each item separately (Harmonized System of Nomenclature)/ SAC code (Services Accounting Code).
3. A declaration to the effect that all invoice particulars are/were uploaded in the GSTN network/ portal & all tax liability as per GST rules and regulations have been and will be discharged, shall be mentioned in the invoice. If not mentioned in the invoice, a separate declaration shall be submitted as per the requirement of BHEL.
4. In case of discrepancy in the data uploaded by supplier in the GSTN portal or in case of any shortages or rejection in the supply, then BHEL will not be able to avail the tax credit and will notify the supplier of the same. Supplier has to rectify the data discrepancy in the GSTN portal or issue credit note (details to be uploaded in GSTN portal) for the shortages or rejections in the suppliers, within the calendar month notified by BHEL.

For any such delay in availing of tax credit for reasons attributable to supplier (as mentioned above), interest (calculated @ SBI Base Rate + 6%) along with penalty if any will be deducted for the delayed period i.e. from the month of receipt till the month tax credit is availed, from the running bills.

Name of Works: **SERVICE CONTRACT FOR PREPARATION OF SAMPLES USING EDM (ELECTRIC DISCHARGE MACHINING) PROCESS FOR BHEL -TRICHY DURING 2019-20.**

Enquiry No.: **BHEL-TRY/ WCM/9471900057 / 17.05.2019**

10. Orders under the Contract:

All orders, notices etc. to be given under the contract shall be in writing, typescript or printed and if sent by registered post to the address given in the tender of the Contract, shall be deemed to have been served on the date, when in the ordinary course they would have been delivered to him. The Contractor shall carry out without delay all orders given to him.

11. Contractor's Supervision:

1. The Contractor shall either himself supervise the execution of the contract or shall appoint a competent agent acceptable to BHEL Officials.
2. Orders given to the Contractor's agent shall be considered to have the same force as if they have been given to the Contractor himself.
3. The Contractor or his accredited agent shall attend when required without making any claim for doing so to the OFFICER-INCHARGE, to receive instructions.
4. The respective area HOD shall have full powers and without assigning any reason, requires the Contractor to immediately cease to employ in connection with this contract, any agent, servant or employee where continued employment is, in his opinion undesirable. The Contractor shall not be allowed any compensation on this account.

12 Payment to employees engaged by the contractor:

1. The Contractor shall remain liable for the payment of all wages and other payments in connection with the employees engaged by him and with regard to the work.
 2. The Contractor shall comply with the applicable provisions of Payment of Wages Act-1936, Minimum Wages Act-1948, Employees' Liability Act-1938, Employees' Compensation Act-1923, Payment of Bonus, EPF and Miscellaneous Provisions Act-1952, Employees' State Insurance Act-1948 and other relevant Acts and rules framed, thereunder from time to time.
 3. Contractor shall be responsible for making payment of wages within 7 days from the last day of wage period and shall obtain the signature at the end of entries in the wage register from area in-charge of contract operating department.
 5. Contractor should ensure that at least the prevailing minimum wages, as per the rules of Government of Tamil Nadu, which are applicable are paid to his employees ONLY in their respective nationalized bank accounts by means of NEFT/ RTGS/ IMPS.
 - 6 The contractor should remit the salary/wages of their workmen only through nationalized Bank, directly to the salary/savings account of the employee concerned. monthly clearance will be given in respect of those contractors, only if the salary/wages to the workmen concerned has been remitted in the nationalized bank account of the workmen. The relevant Bank statement/proof for Bank payment should be produced along with PF and ESI challans every month.
 - 7 No other mode of payment (hand payment / account transfer other than salary or any other) is acceptable as salary.
 - 8 The contractor should pay the previous month salary in full to our employees before 7th of every month and will not adjust with any advance/ loan /training cost / accommodation cost / repayment due by the employee to us.

If the Contractor employs more than twenty employees, he has to obtain License to this effect from the Factory Inspectorate and renew the same periodically.
 - 9 The Contractor should follow and comply with Minimum Wages, ESI, PF, Bonus, Group Insurance and other statutory regulations as stipulated in Factories Act and other applicable State / Central Governments' rules & regulations.
- 12 Each contract employees must have his own PF and ESI Codes and comply with the relevant Acts.

13. Precautions against Risk:

The Contractor shall be responsible for providing at his own expense for all precautions to prevent loss or damage from any and all risks and to minimize the amount of any such loss or damage and for the necessary steps to be taken for the said purpose.

14. Damage & Loss to Private Property & Injury to workmen:

The Contractor shall at his own expense reinstate and make good to the satisfaction of the respective area **HOD** and pay compensation for any injury, loss or damage occurred to any property or rights whatever including property and rights of BHEL (or agents) servants or employee of BHEL, the injury loss or damage arising out of or in any way in connection with the execution or purported execution of the contract and further the contractor shall indemnify BHEL against all claims enforceable against BHEL (or any agent, servant or employee of BHEL) or which would be so enforceable against BHEL, in respect of any such injury (including injury resulting in death) loss or damage to any person whomsoever or property including all claims which may arise under the Employees Compensation Act or otherwise.

15. Laws Governing the Contract:

The contract shall be governed by the Indian Laws for the time being in force.

16. Cancellation of Contract for Corrupt Acts:

BHEL, whose decision shall be final and conclusive, shall without prejudice to any other right or remedy which shall have accrued, shall accrue thereafter to BHEL cancel the contract in any of the following cases and the Contractor shall be liable to make payment to BHEL for any loss or damage resulting from any such cancellation to the same extent as provided in the case of cancellation for default.

If the Contractor shall:

- a) Offer or give or agree to give to any person in BHEL service any gift or consideration of any kind, as an inducement or reward for doing or for bearing to do or for having done or for having borne to do any act, in relation to the obtaining or execution of this or any other contract for BHEL service,
OR
- b) enter into a contract or understanding with any person in BHEL in connection with which commission has been paid or agreed to be paid by him or with his knowledge, unless the particulars of any such commission and the terms of payment thereof have previously been disclosed in writing to BHEL,
OR
- c) To obtain' a contract with BHEL as a result of ring tendering or by non-bonafide methods of competitive tendering, without first disclosing the fact in writing to BHEL.

17. Cancellation of Contract for Insolvency Assignment of Transfer or Subletting of Contract:

BHEL, without prejudice to any other right or remedy, which shall have accrued or shall accrue thereafter to BHEL, shall cancel the contract in any of the following cases:

If the Contractor,

- a) Being an individual or if a firm any partner thereof shall at any time be adjudged bankrupt or have a receiving order for administration of his estate, made against him or shall take any proceedings for liquidation or composition under any bankruptcy Act or assignment of his effects of composition or arrangement for the benefit of his creditors or purport to do so, or if any application made under any Bankruptcy Act for the time being in force for the sequestration of his estate or if a trust deed be granted by him on behalf of his creditors.
OR
- b) Being a Company, shall pass a resolution or Court shall make an order for the liquidation of its assets, or a receiver or Manager on behalf of the debenture holders shall be appointed or circumstances shall arise which entitle the Court or debenture holders to appoint a receiver or Manager.
OR
- c) Assigns, Transfers, Sublets or attempts to assign, transfer or sublet any portion of the work.

- d) Whenever BHEL exercises the authority to cancel the contract under these conditions, BHEL may have the work done by any means at the Contractor's risks and expenses provided always that in the event of the cost of the work so done (as certified by the respective area **HOD**) being less than the contract cost, the advantage shall accrue to BHEL and if the cost exceeds the money due to Contractor under the contract, the Contractor shall either pay the excess amount ordered by the respective area **HOD** or the same shall be recovered from the Contractor by other means.
- e) In case BHEL carries out the work under the provisions of this condition, the cost to be taken into account in determining the excess cost to be charged to the Contractor under this condition shall consist of the cost of the materials, hire charges of tools and plants and / or labour provided by BHEL with an addition of such percentage to cover superintendence and establishment charges as may be decided by the respective area **HOD** whose decision shall be final and conclusive.
- f) Labour engaged by the contractor should be disciplined & exhibit good behaviour in dealing with employees of BHEL. Any misbehaviour or undesirable conduct of any person engaged by the contractor is reported, contractor shall change that person immediately or else it may even lead to termination of the contract & in such case security deposit will be forfeited as penalty.

18. Cancellation of Contract in Part or Full for Contractor's Default:

If the contractor:

- a) makes default in carrying out the work as directed and continues in that state after a reasonable notice from the respective area **HOD** or his authorized representative:
- b) fails to comply with any of the terms & conditions of the contract or failure to comply orders after reasonable notice in writing with orders properly issued thereunder:

BHEL, May without prejudice to any other right or remedy which shall have accrued or shall accrue thereafter to BHEL CANCEL the contract as whole or in part thereof or only such work order or items of work in default from the contract. Whenever BHEL exercises the authority to cancel the contract as a whole or part under this condition, BHEL may complete the work at the contractor's risk and cost (as certified by the respective area **HOD** which is final and conclusive) being less than the contract cost, the advantage shall accrue to BHEL. If the cost exceeds the money due to the Contractor under this contract, the Contractor shall either pay the excess amount ordered by the respective area **HOD** or the same shall be recovered from the Contractor by other means. In case BHEL carries out the work or any part thereof under the provisions of the conditions the cost to be taken into account in determining the excess cost to be charged to the Contractor under this condition shall consist of the cost of the materials, hire charges of tools and plant and/or labour provided by BHEL with an addition of such percentage to cover the superintendence and establishment charges as may be decided by the respective area **HOD** whose decision shall be final and conclusive.

19. Termination of Contract on Death of Contractor:

Without prejudice to any of the rights or remedies under this contract, if the Contractor dies, or if the firm is dissolved or the company is liquidated, BHEL shall have the option of terminating the contract without compensation to the Contractor.

20. Special Power to Termination:

If at any time after the award of contract, BHEL shall for any reason whatsoever not require whole or any part of the work to be carried out the respective area **HOD** shall give notice in writing of the fact to the Contractor who shall have no claim to any payment of compensation or otherwise howsoever on account of any profit or advantage which he might have derived from the execution of the work in full but which he did not derive in consequence of the foreclosing of the work.

21. Recovery from Contractor:

Whenever under the contract, any sum of money, shall be recoverable from or payable by the Contractor, the same may be deducted from or any sum then due or which at any time thereafter may become due to Contractor under the contract or under any other contract with BHEL or from his Security Deposit unless the contractor pays the claim on demand.

Name of Works: **SERVICE CONTRACT FOR PREPARATION OF SAMPLES USING EDM (ELECTRIC DISCHARGE MACHINING) PROCESS FOR BHEL -TRICHY DURING 2019-20.**

Enquiry No.: **BHEL-TRY/ WCM/9471900057 / 17.05.2019**

22 Post- Technical Audit of Work and Bills:

BHEL reserves the right to carry out the post-payment Audit and technical examination of the work and final bill including all supporting vouchers, abstracts etc., and enforce recovery of any sum becoming due as a result thereof in the manner provided in the presiding sub- paragraphs. However, no such recovery shall be enforced after three years of passing the final bill.

23. Refund of Security Deposit:

The Security Deposit may be refunded to the Contractor after completion of the contract provided, after the Contractor shall first have been paid the last and final bill and have rendered a "NO DEMAND CERTIFICATE".

24. Force Majeure Clause:

If, at any time during the continuance of this Contract the performance in whole or in part by either party of any obligations under this Contract shall be prevented or delayed by reason of any War, Hostile acts of the public enemy Civil Commotion, Epidemics, or Acts of God (Floods, Storm/Cyclone, Hurricane, Earthquake etc.) then provided notice of happening of any such event is given by either party to other within 7 days from the date of occurrence thereof neither of the parties shall by reason of such event be entitled to terminate this Contract or claim for damages against the other in respect of such non-performance or delay for such period. Performance under the contract shall be resumed as soon as practicable after such event has come to an end or ceased to exist. If the performance in whole or part of any obligation under this Contract is prevented or delayed by reason of any such event, claims for extension of time may be granted for periods considered reasonable by the respective area **HOD** at his discretion subject to prompt notification by the contractor.

25. Arbitration:

Except as provided elsewhere in this Contract, in case amicable settlement is not reached between the Parties, in respect of any dispute or difference; arising out of the formation, breach, termination, validity or execution of the Contract; or, the respective rights and liabilities of the Parties; or, in relation to interpretation of any provision of the Contract; or, in any manner touching upon the Contract, then, either Party may, by a notice in writing to the other Party refer such dispute or difference to the sole arbitration of an arbitrator appointed by Head of the BHEL Tiruchirappalli.

The Arbitrator shall pass a reasoned award and the award of the Arbitrator shall be final and binding upon the Parties.

Subject as aforesaid, the provisions of Arbitration and Conciliation Act 1996 (India) or statutory modifications or re-enactments thereof and the rules made there under and for the time being in force shall apply to the arbitration proceedings under this clause. The seat of arbitration shall be Tiruchirappalli (the place from which the contract is issued)

The cost of arbitration shall be borne as per the award of the Arbitrator. Subject to the arbitration in terms of Clause above, the Courts at **Tiruchirappalli** (PI incorporate the name of the place where the Principal Civil Court having ordinary original civil jurisdiction to decide questions forming subject matter of the arbitration is located) shall have exclusive jurisdiction over any matter arising out of or in connection with this Contract.

Notwithstanding the existence or any dispute or differences and/or reference for the arbitration, the Contractor shall proceed with and continue without hindrance the performance of its obligations under this Contract with due diligence and expedition in a professional manner except where the contract has been terminated by either party in terms of this contract.

Name of Works: **SERVICE CONTRACT FOR PREPARATION OF SAMPLES USING EDM (ELECTRIC DISCHARGE MACHINING) PROCESS FOR BHEL -TRICHY DURING 2019-20.**

Enquiry No.: **BHEL-TRY/ WCM/9471900057 / 17.05.2019**

In case of contract with Public Sector Enterprises (PSE) or a Government Department, the following shall be applicable

In the event of any dispute or difference relating to the interpretation and application of the provisions of the Contract, such dispute or difference shall be referred by either Party for arbitration to the sole arbitrator in the Department of Public Enterprises to be nominated by the Secretary to the Government of India in-charge of the Department of Public Enterprises. The Arbitration and Conciliation Act, 1996 shall not be applicable to arbitration under this clause. The award of the arbitrator shall be binding upon the Parties to the dispute, provided, however, any Party aggrieved by such award may make further reference for setting aside or revision of the award to the Law Secretary, Department of Legal Affairs, Ministry of Law and Justice, Government of India. Upon such reference the dispute shall be decided by the Law Secretary or the Special Secretary or Additional Secretary when so authorized by the Law Secretary, whose decision shall bind the Parties hereto finally and conclusively. The Parties to the dispute will share equally the cost of arbitration as intimated by the Arbitrator.

26. JURISDICTION:

In case of any suit or other legal proceedings arising under or relating to this Contract, the courts at Trichy, Tamil Nadu only shall have the Jurisdiction and is only after exhausting the, Arbitration, Clause 25.

27 SECRACY OF CONFIDENTIAL INFORMATION:

The Contractor undertakes and agrees that he/it will not disclose or reveal in part or full the proprietary/confidential information, which terms shall mean and include patents, trademarks, service marks, registered designs, copyright, design rights, know-how, confidential information, trade and business names and any other similar protected information of BHEL received during negotiation or currency of the contract to any third party or governmental authorities without written permission from BHEL. In the event of termination or expiry of the contract, the contractor shall return all proprietary/confidential information to BHEL. This clause shall survive termination or expiry of the contract.

BHEL reserves the right to initiate appropriate action including legal proceeds / termination of contract, recovery of damages, penalties etc., if the contractor is found guilty / wrong usage of the documents given by BHEL for any unauthorised activity.

28. Signing of Contract:

Each contract document shall be signed by the Contractor with his usual signature. Contract by partnership or Hindu Joint Family firm, may be signed in the FIRM'S name by the Managing Partner or all /one of the Partners on behalf of the firm or the Karta or Manager for HUF as the case may be. Contract by a Company shall be signed with the name of the Company from a person authorised in this behalf and a Resolution or power of attorney or other satisfactory proof, showing that the person signing the Contract documents on behalf of the Company is duly authorised to do so, shall accompany the contract.

29 FRAUD PREVENTION POLICY

The Bidder along with its associate / collaborators / sub – vendors / consultants / service providers shall strictly adhere to BHEL Fraud Prevention Policy displayed on BHEL website <http://www.bhel.com> and shall immediately bring to the notice of BHEL Management about fraud or suspected fraud as soon as it comes to their notice”.

Fraud Prevention policy and List of Nodal Officers shall be hosted on BHEL website, vendor portals of Units / Regions intranet.

30. SUSPENSION OF BUSINESS DEALINGS WITH SUPPLIERS / CONTRACTORS:

Penal action can be initiated on the suppliers / Contractors in line with extant ‘Guidelines for Suspension of Business Dealings with Suppliers/ Contractors. The abridged version of extant ‘Guidelines for suspension of business dealings with suppliers/ contractors’ has been uploaded on <http://www.bhel.com> on “supplier registration page”.

Name of Works: **SERVICE CONTRACT FOR PREPARATION OF SAMPLES USING EDM (ELECTRIC DISCHARGE MACHINING) PROCESS FOR BHEL -TRICHY DURING 2019-20.**

Enquiry No.: **BHEL-TRY/ WCM/9471900057 / 17.05.2019**

31. RISK PURCHASE:

a) In the event of any successful Tenderer's failure to fulfil any of the tender / Contract obligations as per Contract / Agreement, BHEL may entrust the job to alternate vendor and get it completed to meet the BHEL requirement and additional expenditure, if any, including consequential cost viz., demurrage etc., will be fully recovered from the Contractor who failed to complete the job in line with the Contract.

b) The decision of BHEL with regard to the actual losses / consequential expenditure incurred by BHEL shall be final and binding on the Contractor.

In case vendor fails to fulfil any of the tender / Contract obligations as per Contract / Agreement, contract shall be cancelled and SD shall be forfeited

33. Notices of Accidents

In the event of an accident the Contractor shall be required to fill injury report and submit to the Engineer In charge immediately and ensure compliance of ESI / Workmen's Compensation of accident as per the Act. The Contractor shall get the Contract personnel engaged by him insured under workmen's compensation policy from any Insurance company in India before actually starting the work. The Insurance Coverage should be for the entire period of Contract. The Contractor shall comply with the provisions of the Workmen's Compensation Act 1923. (This should be read in connection with the provisions of ESI Act.)

34. PROVISION FOR MICRO & SMALL ENTERPRISES (MSE) SUPPLIERS:

1. MSE suppliers can avail the intended benefits only if they submit along with the offer, self-attested copies of UAM along with CA Certificate (As per Annexure-I of tender document) issued for latest financial year ending on 31st March 2018 or later / Valid EM-II with deemed validity of five years from the date of issue of EM-II as on date of technical bid opening / EM-II along with latest CA certificate (As per Annexure-I of tender document) issued for latest financial year ending on 31st March 2018 or later where deemed validity of five years is expired / Valid NSIC Registration Certificate as on date of technical bid opening / Valid Registration to any other body as specified by ministry of MSME.

2. Definitions of MSEs owned by Women is under:

2.1 In case of proprietorship firm, proprietor must be woman.

2.2 In case of partnership firm, the women partners must be holding at least 51% shares in the unit.

2.3 In case of private limited companies, at least 51% share must be held by women promoters.

3. *Definitions of MSEs owned by SC/ST is under:*

3.1 In case of proprietorship firm, proprietor must be SC/ST.

3.2 In case of partnership firm, the SC/ST partners must be holding at least 51% shares in the unit.

3.3 In case of private limited companies, at least 51% share must be held by SC/ST promoters.

4. *Authorized Offices to Issue SC/ST certificate. The caste/Tribe/Community certificate issued by the following authorities in the prescribed form for SCs/STs can be considered.*

2.2 In case of partnership firm, the women partners must be holding at least 51% shares in the unit.

2.3 In case of private limited companies, at least 51% share must be held by women promoters.

3. *Definitions of MSEs owned by SC/ST is under:*

3.1 In case of proprietorship firm, proprietor must be SC/ST.

3.2 In case of partnership firm, the SC/ST partners must be holding at least 51% shares in the unit.

3.3 In case of private limited companies, at least 51% share must be held by SC/ST promoters.

Name of Works: **SERVICE CONTRACT FOR PREPARATION OF SAMPLES USING EDM (ELECTRIC DISCHARGE MACHINING) PROCESS FOR BHEL -TRICHY DURING 2019-20.**

Enquiry No.: **BHEL-TRY/ WCM/9471900057 / 17.05.2019**

4. Authorized Offices to Issue SC/ST certificate. The caste/Tribe/Community certificate issued by the following authorities in the prescribed form for SCs/STs can be considered.

4.1 District Magistrate / Additional District Magistrate / Collector / Deputy commissioner / Additional Deputy commissioner / Deputy collector/ 1st class stipendiary magistrate/ Sub divisional Magistrate/ Taluka Magistrate/ Executive magistrate/ Extra Assistant commissioner.

4.2 Chief Presidency magistrate/ Additional chief presidency magistrate/ Presidency magistrate.

4.3 Revenue Officer not below the rank of tahsildar.

4.4 Sub-Divisional officer of the area where the individual and/ or his family normally resides.

4.5 To avail the benefits of MSE under SC/ST category, the related documents as stated above should be submitted along with tender documents.

5. If non-MSE vendor is L1, participating MSE quoting price within price band of L1+15% shall be counter-offered L1 rate(s). If the MSE vendor(s) accepts the counter-offered L1 rate(s), then -

5.1 In case splitting is proposed in tender, minimum **25 %** or minimum value proposed for a vendor (whichever is higher) will be awarded to MSE. In case no splitting is proposed in tender, 100 % work will be awarded to MSE bidder after acceptance of L1 rate by MSE bidder.

5.2 The preference to the MSEs will be given in order of their ranking L1, L2, L3, etc.

Non Submission of such documents along with the offer or during technical evaluation will lead to consideration of their bids at par with other bidders and no benefits shall be applicable for this enquiry though the bidder is MSE.

35.Preference to Make in India:

“For this procurement, Public Procurement (Preference to Make in India), Order 2017 dated 15.06.2017 & 28.05.2018 and subsequent Orders issued by the respective Nodal Ministry shall be applicable even if it is issued after this NIT but before finalization of contract / PO / WO against this NIT. In the event of any Nodal Ministry prescribing higher or lower percentage of purchase preference and / or local content in respect of this procurement, same shall be applicable.

PART-I (TECHNO COMMERCIAL BID)

ANNEXURE-ID

SPECIAL TERMS & CONDITIONS OF CONTRACT

1. PARTICIPATION.

- The Parties who have been suspended or black listed or issued with "Show Cause Notice "by BHEL Trichy-14 or any other BHEL Unit will not be allowed to participate in the Tender.
- Other than the bidder None of its group concerns or affiliates etc. are participating in the tender either directly or indirectly through any other agency under same proprietor / common director(s) / common partner(s).

The bidder should declare the same in the Tender. Even during the course of evaluation / finalization of Tender if it is found that some of the parties are not fulfilling the above clauses, BHEL will not consider them for further participation in the Tender.

2. EVALUATION CRITERIA:

- a. Technical Bids of tenderers will be evaluated based on the Pre-Qualification/Technical Eligibility Criteria on the basis of supporting documents and track record of the bidder.
- b. Price Bids of only those tenderers who are found to meet the Pre-Qualification/Technical Eligibility Criteria will be opened. Price Bids will be opened with prior information to the eligible bidders to facilitate the presence of the bidders or their authorized representatives to witness the Price Bid opening.

3. CRITERIA FOR AWARD OF WORK:

1. The evaluation of offer for award of work shall be on the basis of "Total Cost to BHEL/ **Net Cash outflow to BHEL after taking into account applicable Taxes and Duties.**
2. **The work will be awarded on Package Wise L1 basis. Vendor shall quote for all items of BOQ / Price bid.**
3. In case of more than one L1 bidders for respective schedules, BHEL will invite fresh revised reduced price bids from all such L1 bidders & ranking will be decided based on these revised bids. The new rates quoted should be lower than their previous L1 rates. In case if the revised bids submitted by L1 bidders is also same and none of the bidders are ready for further reduction in their rates, then L1 bidder will be selected on draw of lots. **In such cases Non-MSE Bidders will not be considered for draw of lots.**
4. The quantity mentioned in BOQ / Price bid is tentative. BHEL reserves the right to increase or decrease the quantity during award of work or issue work order in phase manner as per requirement of BHEL.

**4. METHOD OF EVALUATION OF PRICES
Priority / Ranking**

1. Net cash outflow to BHEL including all charges, incidentals etc., inclusive of Goods & Service tax.

5. RATE FINALIZATION

1. Lowest prices received against BHEL Tenders need not be the acceptable to BHEL and in that case BHEL would not be considered the same for award of Contract. BHEL would negotiate or re-float the Tender opened if L1 price is not the lowest acceptable price to them inter-alia other reasons.
2. BHEL will finalize the rates through price bid opening. Hence Tenderers are requested to give their best prices at the first instant itself.

Name of Works: **SERVICE CONTRACT FOR PREPARATION OF SAMPLES USING EDM (ELECTRIC DISCHARGE MACHINING) PROCESS FOR BHEL -TRICHY DURING 2019-20.**

Enquiry No.: **BHEL-TRY/ WCM/9471900057 / 17.05.2019**

3. In the event of the final L1 prices are not reasonable / acceptable to BHEL, BHEL also may resort to short closure of this open Tender.

6. SPLITTING OF CONTRACT:

No splitting is proposed and total work shall be awarded to single vendor.

7. DISCREPANCY IN WORDS & FIGURES- QUOTED IN PRICE BID:

- I. If, in the price structure quoted for the required goods / services / works, there is discrepancy between the unit price and the total price (which is obtained by multiplying the unit price by the quantity), the unit price shall prevail and the total price corrected accordingly, unless in the opinion of the purchaser there is an obvious misplacement of the decimal point in the unit price, in which case the total price as quoted shall govern and the unit price corrected accordingly.
- II. If there is an error in a total corresponding to the addition or subtraction of subtotals, the subtotals shall prevail and the total shall be corrected; and
- III. If there is a discrepancy between words and figures, the amount in words shall prevail, unless the amount expressed in words is related to an arithmetic error, in which case the amount in figures shall prevail subject of (I) and (II) above.
- IV. If there is such discrepancy in an offer, the same will be conveyed to the bidder with target date up to which the bidder has to send his acceptance on the above lines and if the bidder does not agree to the decision of the purchaser, the bid is liable to be ignored.
- V. Bid should be free from correction, overwriting, using corrective fluid, etc. any interlineation, cutting, erasure or overwriting shall be valid only if they are attested under full signature (s) of person(s) signing the bid shall be liable for rejection. All overwriting/ cutting, etc. will be numbered by bid opening officials and announced during bid opening.

Name of Works: **SERVICE CONTRACT FOR PREPARATION OF SAMPLES USING EDM (ELECTRIC DISCHARGE MACHINING) PROCESS FOR BHEL -TRICHY DURING 2019-20.**

Enquiry No.: **BHEL-TRY/ WCM/9471900057 / 17.05.2019**

PART-I (No Deviation certificate)

ANNEXURE-A

Note: The following Declaration to be typed on the contractor's Letter Head, duly signed & stamped and to be attached along with your Technical bid of the tender.

Name of Works: SERVICE CONTRACT FOR PREPARATION OF SAMPLES USING EDM (ELECTRIC DISCHARGE MACHINING) PROCESS FOR BHEL -TRICHY DURING 2019-20.

Enquiry No.: BHEL-TRY/ WCM/9471900057 / 17.05.2019

I/ We have read and clearly understood all the Terms and conditions in Tender Schedule of “SERVICE CONTRACT FOR PREPARATION OF SAMPLES USING EDM (ELECTRIC DISCHARGE MACHINING) PROCESS FOR BHEL -TRICHY DURING 2019-20.” Enquiry No.: BHEL-TRY/ WCM/9471900057 / 17.05.2019 and accordingly we accept the same without any deviation what so ever.

- I/ We unconditionally agree to all the tender conditions and no new conditions are imposed by us in the technical / price bid. I understand in the event of imposing any condition in the technical / price bid, such condition would be ignored by BHEL and only the prices will be considered for the purpose of evaluation”*
- I/ We confirm that none of our group concern or affiliates etc., appears on the list of banned firms / companies by BHEL (list available on www.bhel.com) nor any of the Director / Partner / proprietor of bidder / such group concern or affiliate etc. are involved with such company.*
- I/ We also declare that, we have not been suspended or black listed or issued with Show Cause Notice by BHEL- Trichy or any other BHEL Unit or any PSU/ Government organization.*
- I/ We confirm that other than us, none of our group concerns or affiliates etc. are participating in the tender either directly or indirectly through any other agency under same proprietor / common director(s) / common partner(s).*
- I/ We confirm that if any of the above statement / information furnished by us in this tender is found to be false/ fake at any stage of tender evaluation or during execution of contract, BHEL will have the right to initiate appropriate action including legal proceeds / termination of contract, recovery of damages, penalties etc. as deemed fit.*

(Contractor Signature with Seal)

EMD PAYMENT WIDE E-COLLECT

This explains how to make Payments to BHEL- Tiruchirapali and through SBI-Ecollect. Vendors (EMD and SD Payments payable by others) can utilise this facility. Payments can be made using Internet Banking, Debit Cards/Credit Cards etc. SBI Charges a minimum amount (Service Charge) for every transaction. This may vary according to the MODE selected.

STEP BY STEP PROCEDURE:

Login to <https://www.onlinesbi.com>

1. Select State Bank Collect available on the top (pre login page)
2. Accept the terms and conditions and click "PROCEED"
3. Select State "TAMILNADU "and Institution type "INDUSTRY ".
4. Select "BHEL TRICHY under "INDUSTRY".
5. In the next page, Select APPROPRIATE category, fill details correctly & click "SUBMIT".
6. If all details entered are correctly populated, click "CONFIRM "to proceed.
7. Make payment as per your convenience. (Options available are payment of fees through SBI Net Banking, State Bank ATM cum Debit Cards / Other Bank Debit / Credit Cards and through SBI Branches).
8. SAVE & Keep the copy of receipt for future reference.

**HOW TO TAKE RECEIPT FOR A PAYMENT MADE, EVEN ON A LATER DATE:
(PLEASE CHECK THE STATUS BEFORE MAKING PAYMENT SECOND TIME)**

1. Login to www.onlinesbi.com
2. Select State Bank Collect available on the top (pre login page)
3. Accept the terms and conditions and click "PROCEED"
4. Select "PAYMENT HISTORY "option available on the left side of screen.
5. Using two options as mentioned below , you can get the receipt :
 - a. Type the same Date of Birth, Mobile Number which you have entered at the time of making payment through SB collect. Select the date range and submit.
 - b. If you know the payment reference number, then enter the Reference number (DU...) along with anyone information (Date of Birth / Mobile number, which you have entered at the time of making payment). Select the date range and submit.
6. In the next page, take print out of receipt.

Name of Works: **SERVICE CONTRACT FOR PREPARATION OF SAMPLES USING EDM (ELECTRIC DISCHARGE MACHINING) PROCESS FOR BHEL -TRICHY DURING 2019-20.**

Enquiry No.: **BHEL-TRY/ WCM/9471900057 / 17.05.2019**

ANNEXURE-C

PROFORMA (SAMPLE)

(ON BIDDER'S LETTER HEAD)

REF:.....

DT:.....

AUTHORIZATION LETTER FOR PARTICIPATING IN TENDER OPENING

We, M/s..... (name of the Tenderer) hereby

authorizing (name of the representative) to participate in

the Tender opening of **"SERVICE CONTRACT FOR PREPARATION OF SAMPLES USING EDM (ELECTRIC DISCHARGE MACHINING) PROCESS FOR BHEL -TRICHY DURING 2019-20."**

Enquiry No.: **BHEL-TRY/ WCM/9471900057 / 17.05.2019**

The representative's specimen signature is appended below & attested.

(Signature of the representative)

Authorized signature
with seal and address

Name of Works: **SERVICE CONTRACT FOR PREPARATION OF SAMPLES USING EDM (ELECTRIC DISCHARGE MACHINING) PROCESS FOR BHEL -TRICHY DURING 2019-20.**

Enquiry No.: **BHEL-TRY/ WCM/9471900057 / 17.05.2019**

Annexure-D

To THE PURCHASE/CONTRACT EXECUTING AGENCY/BHEL ACCEPTANCE FOR ELECTRONIC FUND TRANSFER / RTGS TRANSFER

| | | |
|--|---|--------------------------------|
| 1 | NAME & ADDRESS OF THE SUPPLIER / SUB-CONTRACTOR | |
| 2 | VENDOR CODE assigned by BHEL | |
| <u>Details of Bank Account:</u> | | |
| 3 | NAME & ADDRESS OF THE BANK | |
| 4 | NAME OF THE BRANCH | |
| 5 | BRANCH CODE | |
| 6 | MICR CODE | |
| 7 | ACCOUNT NUMBER | |
| 8 | TYPE OF ACCOUNT | CURRENT A/C / OD / CASH CREDIT |
| 9 | BENEFICIERY'S NAME | |
| 10 | IFSC CODE OF THE BRANCH | |
| 11 | EMAIL ID | |
| 12 | TELEPHONE/MOBILE NO. | |

CERTIFICATE I / We hereby agree to receive the payments due from BHARAT HEAVY ELECTRICALS LIMITED by the National Electronic Funds Transfer and/or RTGS Transfer mode by credit to my / our above mentioned Bank Account. I / We also agree that payments made to the above mentioned Account is a valid discharge of the liability of Bharat Heavy Electricals Limited. I / We also agree to bear the applicable Bank Charges for the above mode of transfer. A copy of the cheque leaf/cancelled cheque leaf of the above account is sent herewith.

AUTHORISED SIGNATORY WITH NAME SEAL

Banker's Certification

We confirm that we are enabled for receiving RTGS and NEFT credits and we further confirm that the account number of _____
(name of account holder), the signature of the authorized signatory and the MICR and IFSC codes of our Branch mentioned above are correct.

PLACE:

(Manager / Officer's)

DATE:

Signature Under Bank stamp and Name Seal

With Membership No.

(Telephone / Mobile No. _____)

Forwarded to Accounts Dept. We confirm the above details are verified with the records available with us.

Signature of the BHEL Executive with Name Seal (Operating the Contract/Services)

Certificate by Chartered Accountant on letter head for MSE bidder

This is to Certify that M/S (hereinafter referred to as 'company') having its registered office at is registered under **MSMED Act 2006**, Udyog Aadhaar Memorandum(UAM) **No:** dtd:, Category:(Micro/Small/Medium) (Copy enclosed) / Entrepreneur Memorandum(Part

- II) **No:** dtd:, (Copy enclosed)(Strikethrough wherever not applicable)

Further Verified from the Books of Accounts that the investment of the company as per the latest audited financial year As per MSMED Act 2006 is as follows:

1. For Manufacturing Enterprises: Investment in plant and machinery (i.e. original cost excluding land and building and the items specified by the Ministry of Small Scale Industries vide its notification No. S.O.1722(E) dated October 5, 2006 :

Rs.Lacs.

2. For Service Enterprises: Investment in equipment (original cost excluding land and building and furniture, fittings and other items not directly related to the service rendered or as may be notified under MSMED Act, 2006 :

Rs.Lac.

(Strike off whichever is not applicable)

The above investment of Rs.Lacs is within permissible limit of Rs. Lacs for..... Micro / Small (Strike off which is not applicable) Category under MSMED Act 2006.

Or

The company has been graduated from its original category (Micro/Small) (Strike off which is not applicable) and the date of graduation of such enterprise from its original category is (dd/mm/yyyy) which is within the period of 3 years from the date of graduation of such enterprise from its original category as notified vide S.O. No. 3322 E dated 01.11.2013 published in the gazette notification dated 04.11.2013 by Ministry of MSME.

Date:

(Signature)

Name –

Membership Number –

Seal of Chartered Accountant.

Annexure-II

PART-II (PRICE BID)

| SL No | Item Description | UOM | ApproxQty. (A) | Rate in ₹ (₹/ UOM) (B) | Total value in ₹ (C =A X B) |
|-------|---|-----|----------------|--------------------------------------|--------------------------------------|
| 1 | Preparation of Impact sample as per scope of work. | No | 150 | ₹...../- Rupees.....only | ₹...../- Rupees.....only |
| 2 | Preparation of Tensile sample (round) as per scope of work. | No | 100 | ₹...../- Rupees.....only | ₹...../- Rupees.....only |
| 3 | Preparation of Tensile sample (flat) as per scope of work. | No | 50 | ₹...../- Rupees.....only | ₹...../- Rupees.....only |
| 4 | Preparation of Hot tensile (gleeble) sample as per scope of work. | No | 100 | ₹...../- Rupees.....only | ₹...../- Rupees.....only |
| 5 | Preparation of Hot compression (gleeble) as per scope of work. | No | 100 | ₹...../- Rupees.....only | ₹...../- Rupees.....only |
| 6 | Preparation of Vare-straint sample as per scope of work. | No | 75 | ₹...../- Rupees.....only | ₹...../- Rupees.....only |
| 7 | Preparation of CCT sample (gleeble) as per scope of work. | No | 75 | ₹...../- Rupees.....only | ₹...../- Rupees.....only |

Name of Works: **SERVICE CONTRACT FOR PREPARATION OF SAMPLES USING EDM (ELECTRIC DISCHARGE MACHINING) PROCESS FOR BHEL -TRICHY DURING 2019-20.**

Enquiry No.: **BHEL-TRY/ WCM/9471900057 / 17.05.2019**

| | | | | | |
|---------------------------------------|--|----|-----|--------------------------------------|--------------------------------------|
| 8 | Preparation of stress corrosion sample as per scope of work. | No | 50 | ₹...../- Rupees.....only | ₹...../- Rupees.....only |
| 9 | Preparation of Flat blanks sample as per scope of work. | No | 100 | ₹...../- Rupees.....only | ₹...../- Rupees.....only |
| 10 | Preparation of V notch for CTOD samples by EDM as per scope of work. | No | 50 | ₹...../- Rupees.....only | ₹...../- Rupees.....only |
| 11 | Preparation of Pellini drop weight samples-Machining as per scope of work. | No | 25 | ₹...../- Rupees.....only | ₹...../- Rupees.....only |
| 12 | Preparation of Pellini drop weight samples-Notch cutting on hard faced deposition as per scope of work. | No | 50 | ₹...../- Rupees.....only | ₹...../- Rupees.....only |
| 13 | Preparation of Ultrasonic reference block sample as per scope of work. | No | 5 | ₹...../- Rupees.....only | ₹...../- Rupees.....only |
| Total offer Value (₹) | | | | | |
| GST @ % (₹) | | | | | |
| Total offer value including GST % (₹) | | | | | |

- No pre conditions other than tender terms & conditions will be entertained by BHEL.**
- The signature at the bottom of the price bid confirms that the tenderer has read and accepted all the terms and conditions of tender and rates quoted are inclusive of all taxes and duties levied excluding GST. has been considered by the tenderer for the total contract period while quoting the above rates.