

DRAWING NO. 3-V-3245-24532

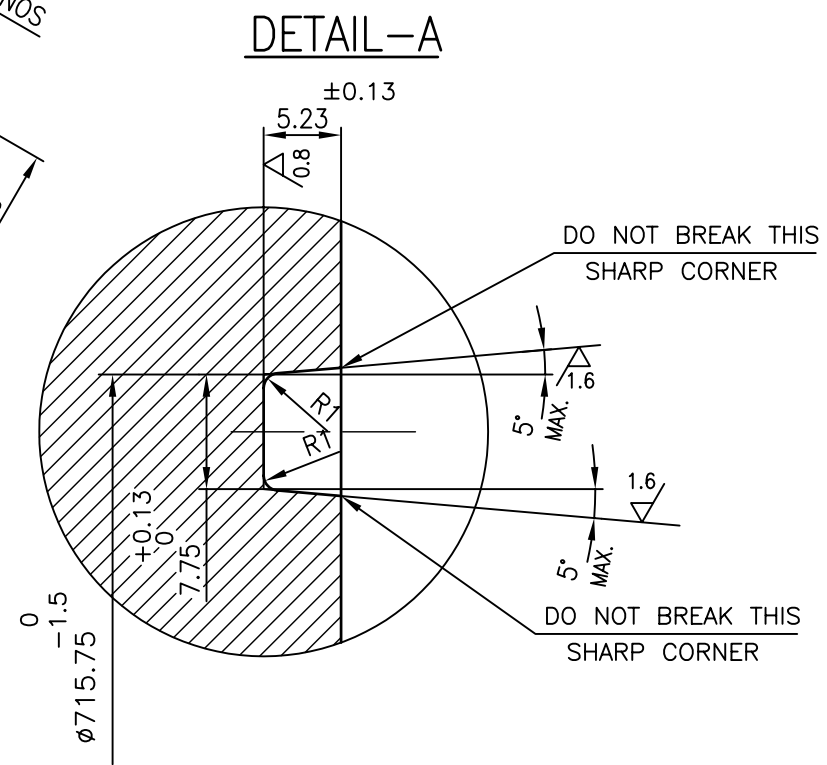
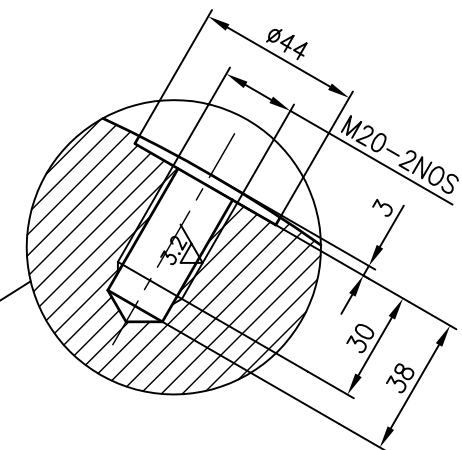
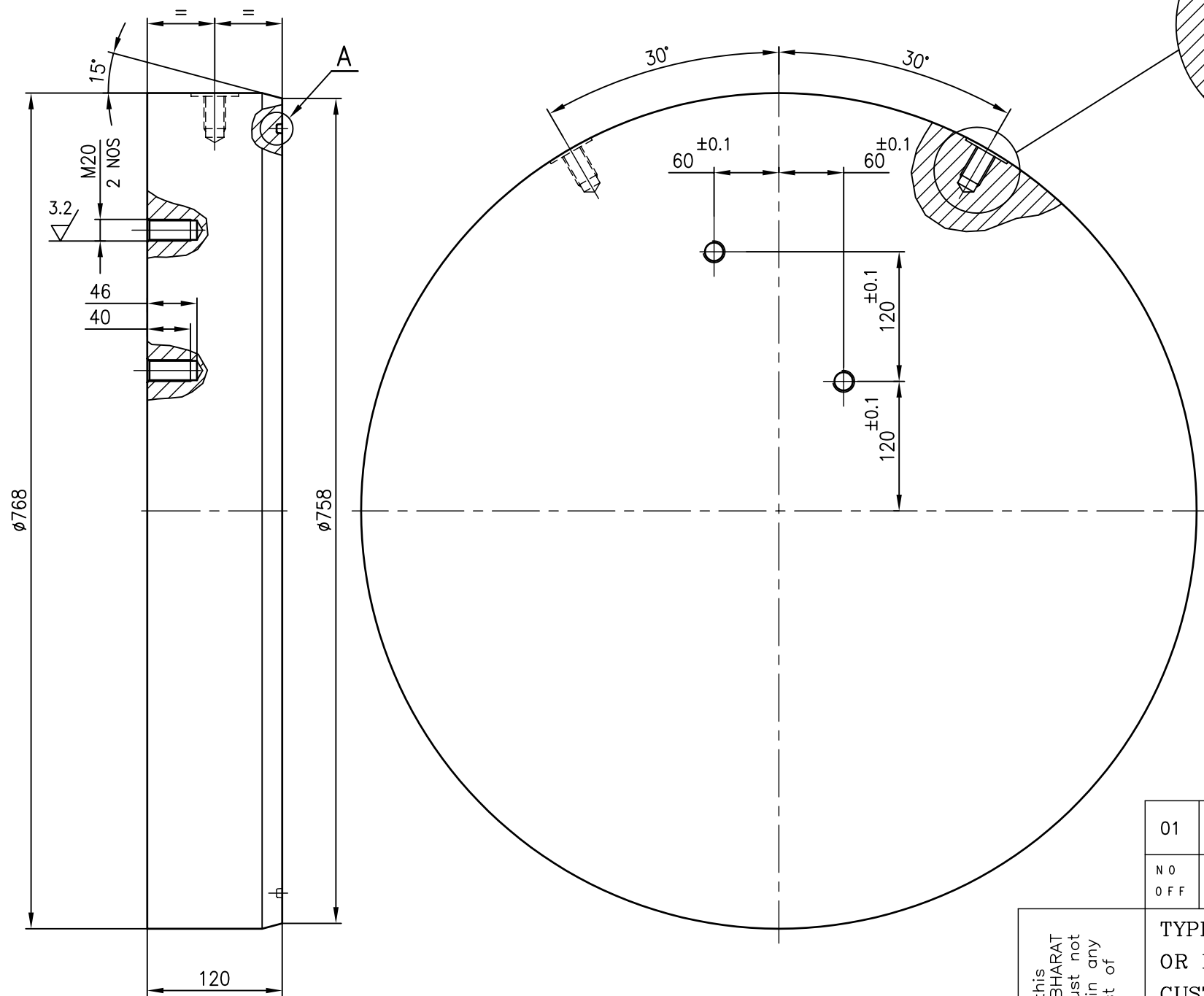

NOTE

- 01. BEFORE DRILLING AND TAPPING M20 THEIR ALIGNMENT WITH THE HOLES IN THE MATCHING LOCKING PLATE TO DRG 3.V.3245.24533 (LATEST REV.) SHALL BE ENSURED BY USING THE LOCKING PLATE AS TEMPLATE.
- 02. UNSPECIFIED SHARP CORNERS TO BE CHAMFERED TO 2X45°.
- 03. 45° CHAMFER FIRST THREAD.

01	PL.127-785X785	15 911 430	SA299 CERTIFY	NORMALISED	10	440.5	614.3	-	005
NO OFF	DESCRIPTION	MATL CODE	MATL SPECN	HEAT TREATMENT	SCRAP SORT	NET WT (kg)	GROSS WT (kg)	DRAWING No	ITEM No

CAUTION: The information on this document is the property of BHARAT HEAVY ELECTRICALS LTD. It must not be used directly or indirectly in any way detrimental to the interest of the company.

TYPE OF PRODUCT OR NAME OF CUSTOMER/PROJECT

BHARAT HEAVY ELECTRICALS LTD., UNIT: HIGH PRESSURE BOILER PLANT. TIRUCHIRAPALLI-620014.	DRN	M.SRINIVASAN	SIGN	DATE	NO.OF VAR.
	CHD	P.BOOMINATHAN		07.03.07	
	APPD	M.RAJAKUMAR		07.03.07	

REV	DATE	ALTERED
		CHD & APPD

DEPT	VL	SCALE	WEIGHT (KG).	REFERENCE INFORMATION	NO. OF ITEMS
CODE	320	NTS	440.5	COMP. CODE 93 201 037 0000 CAD : F324532	
TITLE			CARD CODE	DRAWING NO.	REV
DISK			U 01	3-V-3245-24532	