



BHARAT HEAVY ELECTRICALS LIMITED
HEEP HARIDWAR INDIA-PIN 249403
FAX NO: 0091 1334 226462
PHONE NO: 0091 1334 284142

Tender No.: **D/6580/17/0661D1**

Sub: BHEL-HEEP/OPEN-TENDER DF/2017-18/2

The Heavy Electricals Equipment Plant (HEEP) located in Haridwar, India is one of the major manufacturing plants of Bharat Heavy Electricals Ltd. The core business of HEEP includes design and manufacture of large steam and gas turbines, turbo generators, Defense Items and so on.

Sealed tenders with the Tender No. and opening date clearly super scribed on the cover are invited from the manufacturers (registered as well as unregistered) for the supply of the following items:-

S. No.	Tender No.	Description of Item	Qty	Delivery Schedule	Opening Date
1	D/6580/17/0661D1	HW7799902248 SEMI-AUTOMATIC DEVICE FOR UNIFORM COATING OF BRONZE BY THERMAL SPRAY PROCESS AS PER SPECIFICATION:DPT0151, REV.NO:00	1 no	31.07.17	19.06.2017

1. PRE QUALIFICATION REQUIREMENT IS AS PER ANNEXURE-1.
2. SPECIFICATION DPT0151 IS AS PER ANNEXURE-2.
3. EARLY DELIVERY IS ACCEPTABLE.
4. DELIVERY IS NOT SACROSANCT. VENDORS TO QUOTE BEST POSSIBLE DELIVERY.
5. ITEM REQUIRED FOR FABRICATION AREA IN DEFENCE SHOP.
6. GUARANTEE CERTIFICATE IS REQUIRED
7. OPERATION AND MAINTENANCE MANUAL IS REQUIRED

The tender documents can be downloaded from our web site www.bhel.com or www.bhelhwr.co.in or www.tenders.gov.in, after downloading the tender documents from web site, while submitting the tender as detailed in "Instruction to Bidders", intending vendors must remit tender fee of Rs. 2,000.00 for indigenous vendors (or equivalent amount in foreign currency for foreign vendors) against each tender if documents (in hard copies) are required from BHEL. **EMD is Nil.**

As per notification reference no. NSIC/HO/GP/15(4)/2013-14 dated 07.07.2013 Micro & Small Enterprises (MSEs) are not required to submit EMD & tender fees. A certificate issued from competent authority shall be submitted in support of Micro & Small Enterprises (MSEs). BHEL will not be responsible for any type of postal delay / incomplete information from vendor.

Amendments/Corrigendum, if any, will be hosted on our web site only. Other terms and conditions will be as per tender documents.

The date for opening of tender shall be 19.06.2017. Tenders will be received up to **1.45 P.M.** on **19.06.2017** and opened on the same day at 2.00 P.M. in the Tender Room. **Please note that tender received after due date & time (1.45 PM on 19.06.2017) will not be REPEAT will not be opened.** BHEL will not be responsible for any type of postal / courier delay.

Foreign and Indigenous bidders against open tender will necessarily have to obtain class – III DSCs. Procedure for application is available on www.bhel.com.

The total quantity may undergo change at the time of ordering.

Documents submitted with the offer/bid by the bidder (original registered supplier) shall be signed and stamped in each page by authorized representative of the bidder. Documents not signed and stamped in each page by the authorized signatory of the bidder, may neither be accepted nor considered for evaluation of the bid.

Any vendor who is under hold (for the item)/ delisted/ banned with BHEL on date of opening of Part – 1 will not be allowed to quote for this tender. In case their offer is received, it may be out rightly rejected.

Please submit your offer only for the above requirement subject to our **GENERAL INSTRUCTIONS AND STANDARD TERMS & CONDITIONS (GISTC)**. Please visit our site www.bhelhwr.co.in for General Instructions and Standard Terms & Conditions (GISTC) for Tender Enquiries. **All the bidders/vendors must ensure compliance of these GISTC.**

BIDS shall be opened at 2.00 PM on the due date in the presence of authorized representative of the bidders who may like to be present. The authorized representative should bring authority letter from their parent company (Manufacturer) for the specific tender no. attending the bid opening.

Unregistered vendors may please visit our site www.bhel.com for filing up the Supplier Registration Form. Copy of filled Supplier Registration Form may be submitted along with the offer.

KINDLY READ “INSTRUCTIONS TO BIDDERS.” QUOTATION NOT IN ACCORDANCE WITH THE INSTRUCTIONS ARE LIABLE TO BE DISQUALIFIED AND IGNORED.

INSTRUCTIONS TO BIDDERS FOR OPEN TENDER

DEFINITION

Registered Vendors - Are those who are registered with BHEL, Haridwar for Megawatt rating/ Size/ Weight of tendered items in respective material grade or machining of such items.

Un-registered Vendors - Are those who are not registered with BHEL, Haridwar for Megawatt rating/ Size/ Weight of tendered items in respective material grade or machining of such items.

ESSENTIAL INSTRUCTIONS

* Un-registered vendors may be approved by BHEL, if found suitable, on the basis of data furnished by them in Supplier Registration Form (SRF) for Foreign Vendors or Indigenous Vendors (as applicable).

* BHEL team may visit the vendor (s) works for verification of capability and capacity claimed in tender documents/offer (s).

* The tenders shall be submitted in two parts in separate sub-envelopes clearly super scribing type of bid, tender no., due date and the name of vendor with full contact details.

❖ **Part I –**

- a. Tender fee (if hard copy insisted from BHEL) OR attested copies of either EM II certificate having deemed validity (five years from the date of issue of acknowledgement in EM II) or valid NSIC certificate or EM II certificate along with attested copy of a CA certificate (if MSE benefits are to be availed),
- b. Supplier Registration Form (As applicable)
- c. Non Disclosure Agreement (Annexure-3)
- d. Pre Qualification Requirement (Annexure-1)
- e. Techno- Commercial Bid - it should be replica of price bid (copy of price bid without price part).

❖ **Part II – Price Bid.**

All the sub-envelopes (Part-I & Part- II) to be put in a single covering envelope indicating tender no., due date and the name of vendor, e-mail id, with full contact details. Offer should be complete in all respect (i.e. Part-I & Part- II).

* Please submit your offer according to **General Instructions and Standard Terms & Conditions (GISTC)** for Tender Enquiries. Please visit our site www.bhelhwr.co.in for GISTC. **All the bidders/vendors must ensure compliance of these GISTC (VERSION: APRIL-16, REV. 00).**

GISTC (VERSION: APRIL-16, REV. 00) can also be referred by login to B2B Portal for Vendors.

PQR

ANNEXURE-1

PRE QUALIFICATION REQUIREMENT (PQR)

SEMI-AUTOMATIC DEVICE FOR UNIFORM COATING OF BRONZE BY
THERMAL SPRAY PROCESS (INDENT No.: 20170661)

Only those vendors (Original manufacturer) who have supplied at least one such type of device/fixture or equivalent in last five years are only eligible to quote. Vendor to submit the purchase order copy of the supplied item with offer.

Sumit Kumar
25/5/17

SUMIT KUMAR

(ENGR. / DABG-TECH)

Rajive Chaurasia
25/5/17

RAJIVE CHAURASIA

(AGM / DABG)

उत्पाद क्रय विनिर्देश
PRODUCT PURCHASE SPECIFICATION
 (DEFENCE TECHNOLOGY)

DPT0151

Page 1 of 4

SEMI-AUTOMATIC DEVICE FOR UNIFORM COATING OF BRONZE BY THERMAL SPRAY PROCESS

COPYRIGHT AND CONFIDENTIAL
 The information on this

- Purpose:** The device is used for holding and rotating the cylindrical job for uniform coating of bronze by thermal spray process. The job is preheated to temperature approx. 500° C. Then thermal spray of bronze powder on the job is done with the help of high velocity oxy fuel (HVOF) torch with oxy-acetylene flame. The main purpose of this device is to achieve uniform coating of bronze on the cylindrical job – Vendor to confirm
- Specification:**
 - The device shall have its independent a.c motor drive for controlled rotation of face plate/chuck with self-centering 3 jaws - Vendor to confirm
 - The self-centering 3-jaw chuck shall be able to hold cylindrical jobs of clamping dia. 30. mm or less to 200 mm or more - Vendor to confirm
 - Swing over bed (SOB) should be 250 mm or more - Vendor to confirm
 - The RPM of the chuck should be minimum 1 or less to 50 or more at increment of 1 rpm or less suitable for uniform coating through thermal spray – vendor to confirm
 - Suitability of device for maximum length of the job 500 mm - Vendor to confirm
 - Suitability of device for maximum weight of the job 35 Kg - Vendor to confirm
 - The hot fumes generated during coating in inner diameter of the job should be removed from chuck/spindle side with the help of fume extractor installed with device. The exhaust fume exit should be around 0.5 m above the center axis of device - Vendor to confirm
 - Complete device shall be mounted on a base plate with chuck axis as horizontal - Vendor to confirm
 - Complete unit consisting of chuck drive, base plate etc. shall be portable with provision for lifting arrangement by overhead crane - Vendor to confirm

स्ववाधिकार गोपनीय
 इस प्रबंध में दी गई जानकारी को गोपनीय माना जाएगा और इसे बिना अनुमति के किसी भी तृतीय पक्ष को प्रकट नहीं किया जा सकता है।

संख्या एवं तारीख
 INVENTORY NO. & DATE

				नाम NAME	दिनांक एवं हस्ताक्षर SIGNATURE & DATE
			अनुवादक TRANSLATED BY		
			निर्माणकर्ता WORKED BY	SUMIT KUMAR	
DEFENCE PROJECT	UJJWAL KUMAR	17/05/17	जांचकर्ता CHECKED BY	RAJIVE CHAURASIA	17/05/17
सहमत-विभाग AGREED DEPTT	नाम NAME	दिनांक एवं हस्ताक्षर DATE & SIGNATURE	पर्यवेक्षणकर्ता SUPERVISED BY		
			स्वीकृति APPROVED : RAJIVE CHAURASIA	17/05/17	Gr. NO. 9
REV.NO - 00			निर्माण PREPARED : DABG	जारी ISSUED : DABG	दिनांक DATE : 17.05.17
DI - 17.05.2017					
CHANGE ADVICE NO.					

SIGN & DATE दिनांक एवं हस्ताक्षर		<h2 style="margin: 0;">उत्पाद क्रय विनिर्देश</h2> <h3 style="margin: 0;">PRODUCT PURCHASE SPECIFICATION (DEFENCE TECHNOLOGY)</h3>	DPT0151 Page 2 of 4
-------------------------------------	---	---	----------------------------

SUPERSEDES INVENTORY नामदीर्घ सूची संख्या की आशुपान संख्या	<p>3. Special Features:</p> <p>3.1 The device should have motor and gear arrangement to drive the chuck – vendor to confirm</p> <p>3.2 The run out of the chuck should be within 0.02 mm (radial as well as facial) – vendor to specify and confirm</p> <p>3.3 Material of all parts of Fume extractor should have capacity to sustain at high temperature fumes (approx. 250° C) - Vendor to confirm</p> <p>3.4 The material of the device like base plate should have heat resistance properties (for temperature approx. 250° C) - Vendor to confirm</p> <p>3.5 There should be adequate thermal protection of all items used in device i.e., motor, gear, belt etc. with capability to work at high temperature approx. 250° C - Vendor to confirm.</p> <p>3.6 The fan speed of fume extractor should be controlled by regulator- Vendor to confirm</p> <p>4. General Requirements:</p> <p>4.1 The thermal spray torch shall be applied by operator from direction opposite/facing towards to chuck for coating internal diameter and from in front/ parallel to the chuck for outer diameter of the job - Vendor to confirm</p> <p>4.2 The device should be vibration free during running or working condition - Vendor to confirm</p> <p>4.3 The device should be compact & portable with easy lifting & shifting - Vendor to confirm.</p> <p>4.4 All bearings used in device should be SKF/RHP/FAG make - Vendor to inform the make</p> <p>4.5 The chuck should be ZITHER/BONET/ROHM make - Vendor to inform the make</p> <p>4.6 The motor should be ABB/L&T/SIEMENS/KIRLOSKAR/CROMPTON make – vendor to inform the make and rating of motor.</p> <p>4.7 The heat is transferred from job's free end to jaws/chuck during coating. So vendor to ensure that, there will not be any distortion and effect of heat (approx.250° C) on material of the chuck and jaws during/ after coating - Vendor to confirm</p> <p>4.8 Connecting cable (10 m) with plugs will be provided by the vendor for connecting device to main power supply at BHEL, Haridwar - Vendor to confirm</p> <p>4.9 All electrical parts & motor should be protected & in-house in cover for safety of operator & equipment - Vendor to confirm</p>	
---	--	--

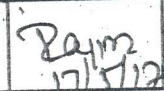
SIGN & DATE दिनांक एवं हस्ताक्षर	REV. NO.: 00		निर्माणकर्ता WORKED BY	SUMIT KUMAR	 17/05/17	17.05.17
INVENTORY NO नामदीर्घ सूची संख्या			जांचकर्ता CHECKED BY	RAJIVE CHAURASIA	 17/05/17	17.05.17

COPYRIGHT AND CONFIDENTIAL
 The information on this document is the property of Bharat Heavy Electrical Limited. It must not be used directly or indirectly in any way detrimental to the interest of the company.

स्वत्वात् एवं गोपनीय
 इस दस्तावेज में दी गई सूचना भारत भारी उपकरण लिमिटेड की संपत्ति है। इसका प्रयोग अन्य किसी व्यक्ति या संस्था के लिए अनुमति के बिना न होना चाहिए। इस दस्तावेज को किसी भी रूप में प्रसारित करना न किया जाय।

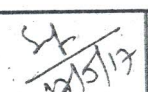
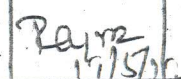
निर्माणकृत SIGN & DATE		<h2 style="margin:0;">उत्पाद क्रय विनिर्देश</h2> <h3 style="margin:0;">PRODUCT PURCHASE SPECIFICATION (DEFENCE TECHNOLOGY)</h3>	DPT0151 Page 3 of 4		
सुपरसेड्स INVENTORY	<p>4.10 All mechanical rotating parts should have suitable provision for oil lubrication - Vendor to confirm</p> <p>4.11 The device shall be used in normal machine shop environment without any temperature controlled enclosure - Vendor to confirm</p> <p>4.12 Maximum weight of the device – Vendor to inform</p> <p>4.13 The device should be properly painted -Vendor to confirm</p> <p>4.14 The device should have operating panel for on/off switch & rpm control etc. – vendor to confirm</p> <p>4.15 Input Power Supply at BHEL: Single phase, 230± 10% Volt, and 50 ± 3% Hz. Input power supply point will be provided by BHEL.</p> <p>4.16 Three sets of operation and maintenance manual documents are to be supplied along with the supply. Detailed electrical circuit & wire diagram should also be supplied along with the supply - Vendor to confirm</p> <p>5. Job Trial, Demonstration & Acceptance:</p> <p>5.1 The device shall be checked for compliance to specifications/scope's all parameters and Establishment of device for coating of one number of component as per drawing enclosed (annexure 1) at BHEL shop - Vendor to confirm</p> <p>5.2 Training to BHEL engineer for operational & maintenance of device at BHEL - Vendor to confirm</p> <p>5.3 Final acceptance shall be subject to successful completion of above 2 activities- Vendor to confirm</p> <p>6. Pre-Dispatch Inspection (PDI)</p> <p>6.1 The device will be inspected at the vendor's works by BHEL Engineers before dispatch to check the compliance to specification & functionality as per technical specification - Vendor to confirm</p> <p>6.2 Vendor to inform BHEL at least two weeks before the date of PDI - Vendor to confirm</p> <p>6.3 Vendor to submit a photo & schematic diagram of device showing all peripherals before PDI - Vendor to confirm.</p> <p>7. Packing: The device shall be dispatched in suitable packing to avoid any damage during handling and transit- Vendor to confirm</p> <p>8. Guarantee: All supplies shall be guaranteed by vendor for 12 months from date of its acceptance at BHEL works – Vendor to confirm</p>				
नमूने नं. मूलांक INVENTORY NO	REV. NO.: 00	निर्माणकर्ता WORKED BY	SUMIT KUMAR	 17/05/17	17.05.17
नमूने नं. मूलांक INVENTORY NO		जांचकर्ता CHECKED BY	RAJIVE CHAURASIA	 17/05/17	17.05.17

COPYRIGHT AND CONFIDENTIAL
 The information on this document is the property of Bharat Heavy Electricals Limited. It must not be used directly or indirectly in any way detrimental to the interest of the company.

स्वतंत्रता
 यह दस्तावेज में दी गई सूचना भारत की आर्थिक स्थिति को सुदृढ़ करने के लिए उपयोग की जानी चाहिए। इस दस्तावेज में दी गई सूचना भारत की आर्थिक स्थिति को सुदृढ़ करने के लिए उपयोग की जाननी चाहिए।

DPT0151



उत्पाद क्रय विनिर्देश

PRODUCT PURCHASE SPECIFICATION (DEFENCE TECHNOLOGY)

Page 4 of 4

ANNEXURE-1

दिनांक एवं संख्या
SIGN & DATE

समर्पण नं.
INVENTORY

समर्पण नं.
INVENTORY

COPYRIGHT AND CONFIDENTIAL
The information on this document is the property of Bharat Heavy Electricals Limited. It must not be used directly or indirectly in any way detrimental to the interest of the company.

स्वत्वता एवं गोपनीय
इस प्रलेख में दी गई सूचना भारत की राष्ट्रियता की सुरक्षा के लिये अत्यंत महत्वपूर्ण है। इस सूचना को बिना अनुमति के किसी भी प्रकार से प्रसारित करना या इस सूचना का उपयोग करना कानूनन दंडनीय है।

दिनांक एवं संख्या
SIGN & DATE

समर्पण नं.
INVENTORY NO.

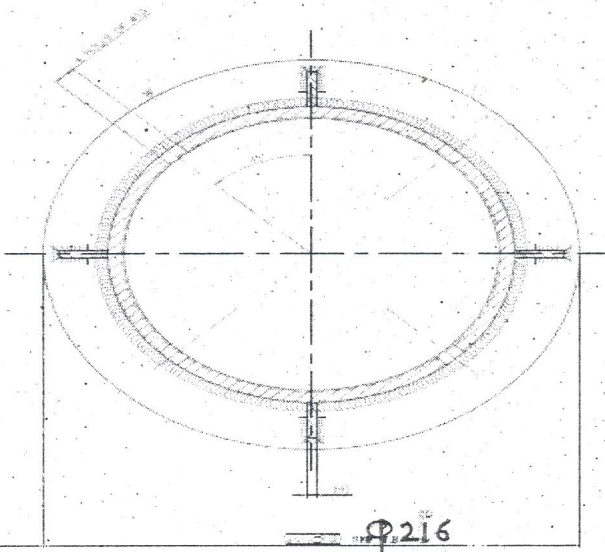
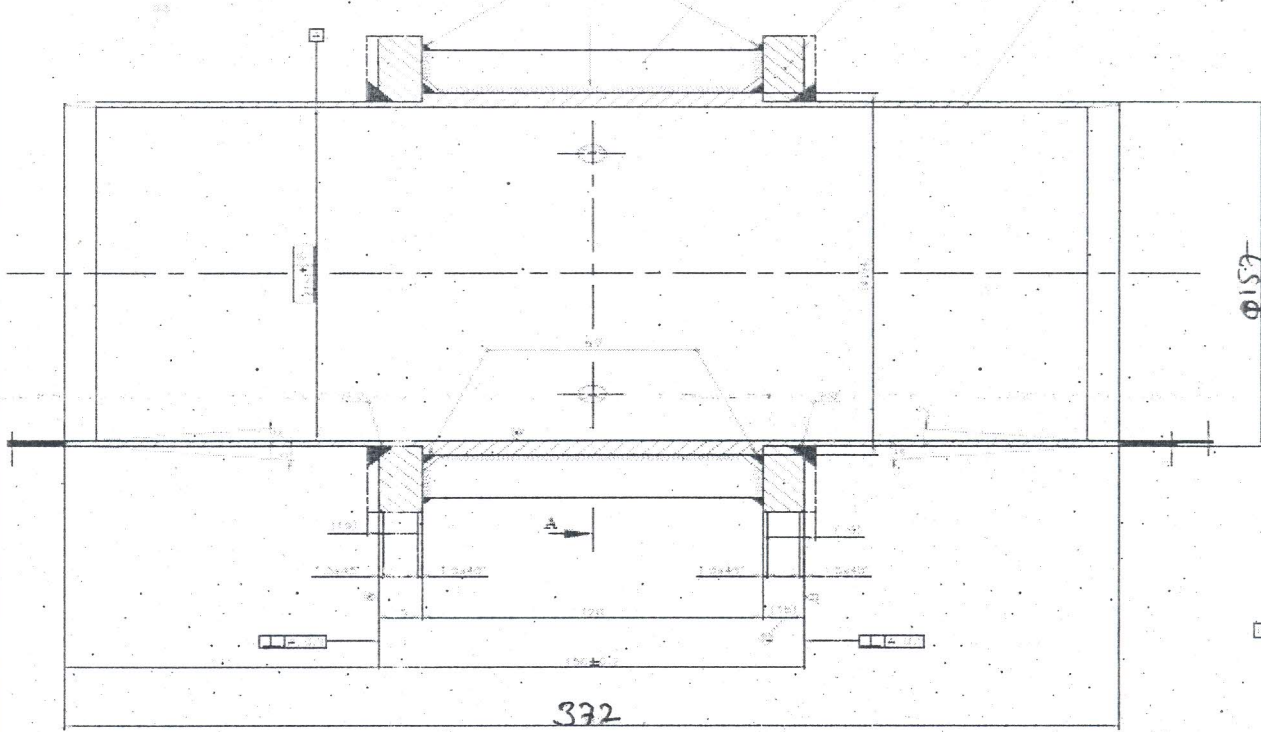

MACHINE TO $\phi 215.4 \pm 0.1$ AND APPLY BRONZE BY EUTALLOY PROCESS WITH 10185 CASTOLIN POWDER TO OBTAIN $\phi 216 \begin{smallmatrix} -0.17 \\ -0.45 \end{smallmatrix}$ AFTER MACHINING FINISHED.

REV. NO.: 00

निर्माणकर्ता WORKED BY	SUMIT KUMAR	<i>S.K.</i> 17/5/17	17.05.17
जांचकर्ता CHECKED BY	RAJIVE CHAURASIA	<i>Rajm.</i> 17/5/17	17.05.17

NON-DISCLOSURE AND PROPRIETARY INFORMATION AGREEMENT

BETWEEN

_____ (**Name of the Vendor**),, having its registered offices in _____ (**Address of Vendor**), registered under the no. _____ of the Companies' register of _____ (**Name of Place and Country**), capital stock of _____ (**Value**), with a place of business in _____ (**Name of Place and Country**) (hereinafter referred to as "**_____ (Name of Vendor)**");

AND

Bharat Heavy Electricals Ltd a company incorporated under the Indian Companies Act 1956 having its registered offices at BHEL House, Siri Fort, New Delhi -110 049 and having one of its works at Heavy Electrical Equipment Plant, Ranipur, Haridwar-249403 (Uttarakhand), India registered under the No. 4281 of 1964-65 of the companies register of Delhi, capital stock of Rs 4895.2 million with a place of registered office in New Delhi (hereinafter referred to as "BHEL") hereinafter also referred to individually as "the Party" or collectively as "the Parties".

BACKGROUND

This Agreement sets forth the rights and obligations of the Parties with respect to the use, handling, protection and safeguarding of Proprietary Information that is disclosed by and between the Parties.

WHEREAS

A) the Parties wish to pursue exploratory discussions concerning a possible collaboration between them in relation to the Program defined in Exhibit 1;

B) during the ensuing discussions and negotiations it may occur that either Party discloses to the other technical, financial or business information of a proprietary or confidential nature, which the Parties intend to protect against, making it available, by any means to any third person, and other unauthorized use and/or further disclosure by the recipient, in accordance with the terms and conditions set forth herein;

NOW, THEREFORE, the Parties have agreed as follows:

1. The term “Proprietary Information” shall mean any information or data of whatsoever kind of a confidential or proprietary nature, including but not limited to, commercial information, know how and technical information in the form of designs, drawings, concepts, requirements, specifications, software, interfaces, components, processes, or the like, that have been or will be disclosed by either Party to the other pursuant to this Agreement, either in writing, orally or other form, which is designated as “Proprietary” or “Confidential” by the disclosing Party by means of formal declaration or an appropriate stamp, legend or any other written or orally notice .

2. Proprietary Information may be conveyed, without limitation, through any written or printed documents, samples, models, electronic form on disk, tape, other storage media or any other means of disclosing such Proprietary Information that either Party may elect to use during the life of this Agreement, but if an originating Party originally discloses information orally or visually, the receiving Party will protect such information as Proprietary Information to the extent that the originating Party :
 - identifies the Information as Proprietary at the time of original disclosure,
 - summarizes the Proprietary Information in writing .

Information stored in electronic form on disk, tape, other storage media will be adequately marked if a proprietary legend displays when the information originally runs on a computer system and when the information is printed from its data file.

Proprietary Information also includes any information which can be obtained by examination, testing or analysis of any hardware or material substance or any component part of such hardware or material substance provided by the Disclosing Party even though the requirements in Clause 1 for marking and designation have not been fulfilled.

3. Each Party, to the extent of its rights to do so, shall disclose to the other only the Proprietary Information which the disclosing Party deems appropriate to fulfil the objectives of this Agreement. The Parties hereby represent that the disclosure of Proprietary Information by and between themselves shall be made in compliance with, and subject to the laws and regulations of the Disclosing Party's country.

4. The receiving Party hereby agrees and covenants that, from the effective date of this Agreement until the expiry date as per article 11 and the following period as per article 12, the Proprietary Information that either Party receives from the other shall:
 - a) be protected and kept in strict confidence by the receiving Party which must use the same degree of care it uses to protect its own confidential information and in no case less than a reasonable care;

 - b) be only disclosed to and used by those persons within the receiving Party's organization or that of its parent or controlled companies who have a need to know and solely for the purposes specified in this Agreement, and be treated by such persons or entities with the same degree of care and subject to the same restrictions;

 - c) to procure that each third party to whom Proprietary Information is disclosed under this Agreement is made aware of the provisions of this Agreement prior to such disclosure to it and that each such third party is

bound by obligations of confidentiality which are no less onerous than those contained in this Agreement;

- d) neither be disclosed nor caused to be disclosed or made available, either directly or indirectly, to any third Party or persons other than those mentioned in subparagraph b) above or other persons upon which both of the contractual Parties shall agree in an amendment to this Agreement;
- e) not to copy, reproduce or reduce to writing any part of such Proprietary Information except as may be reasonably necessary for the purpose referred to in the Recitals of this Agreement

PROVIDED THAT the Receiving Party shall be entitled to make any disclosure required by court order or government or regulatory requirement of the Disclosing Party's Proprietary Information subject to notifying the Disclosing Party as soon as possible of such requirement

- 5. Any Proprietary Information and copies thereof disclosed by either Party to the other shall remain the property of the disclosing Party and shall be immediately returned or destroyed by the receiving Party upon request.
- 6. The receiving Party shall have no obligations or restrictions with respect to any Proprietary Information for which the receiving Party can prove that:
 - a) is in or which comes into the public domain otherwise than as a result of a breach of this Agreement by any person to whom a disclosure of Proprietary Information is made as permitted under this Agreement or of any other duty of confidentiality relating to the Proprietary Information of which the Receiving Party has knowledge; or
 - b) it has been in its possession without restriction at the time of the disclosure, as evidenced by written documentation in its files; or
 - c) it has been lawfully received from a third Party without breach of this Agreement; or

- d) it has been or is published without violation of this Agreement; or
 - e) it has been independently developed in good faith by employees of the receiving Party who did not have access to the Proprietary Information; or
 - f) it has not been properly declared, designated or confirmed as Proprietary or Confidential; or
 - g) the protection period has expired according to articles 11 and 12 of this Agreement.
7. With respect to any exchange of Proprietary Information which may occur as a result of this Agreement, it is expressly understood and agreed that the persons listed in Exhibit 2 shall, on behalf of the respective Parties, be the exclusive individuals authorized to receive from and transmit to the other Party Proprietary Information under this Agreement. Each Party may replace at any time its respective authorized individuals identified in such Exhibit 2, within its own organization. Any such new designation by a Party shall be made by written notice to the other at the address indicated in such Exhibit 2.
8. Any Proprietary Information which is identified as “Classified Information”, or whose export is subject to an export license, shall be identified as such by the disclosing Party at the time of disclosure and the disclosure, protection, use and handling thereof, shall remain subject to the security procedures and restrictions imposed by the disclosing Party's Government.
9. The disclosure of Proprietary Information under this Agreement by either Party to the other shall not be construed as granting to the receiving Party any right, whether express or implied by licence or otherwise, on the matters, inventions or discoveries to which such information pertains, or as granting any trademark, patents, copyrights, trade secret right or other form of intellectual property right.

10. Nothing in this Agreement may be construed as an obligation of either Party to disclose any Proprietary Information to the other, or to enter into any subsequent contractual relationship with such other Party.
11. This Agreement covers the exchange of Proprietary Information which may be made by either Party to the other until ten years from signing of the agreement or any extension thereto which may be agreed upon by the Parties in writing. Proprietary information relevant to the Program detailed in Exhibit 1, already made available to the other contractual Party before the effective date, shall also be protected under this Agreement.

It is understood by the parties that, prior to disclosure, the Disclosing Party shall have obtained any government authorisation needed for the export of the Proprietary Information

12. The expiry of the period contemplated in Article 11 of this Agreement shall not relieve the receiving Party from complying with the obligations imposed by Article 4 here above with respect to the use and protection of the Proprietary Information, received prior the date of such expiry, for a period of ten (10) years after such expiry.
13. The Parties are independent contractors. Each will bear all costs and expenses in connection with this Agreement. This Agreement is intended to facilitate only the exchange of Proprietary Information and is not intended to be, and shall not be construed to create a teaming agreement, joint venture, association, partnership, or other business organisation or agency arrangement and no Party shall have the authority to bind the other without the other Party's separate prior written agreement .
14. This Agreement shall be governed by and shall be interpreted in accordance with the substantive Indian laws. Irrespective of the foregoing each Party shall remain

bound by the provisions of its own national laws and regulations with respect to the transfer or use of Classified Information or information whose export is subject to an export license.

15. All disputes among the Parties, in connection with or arising out of the existence, validity, construction, performance and termination of this Agreement (or any terms thereof), which the Parties are unable to resolve among themselves, shall be finally settled by an Arbitration. The Arbitration shall be held in Haridwar (India), in English language, in accordance with the rules laid down in the arbitration and reconciliation act of India.
16. The foregoing constitutes the entire Agreement among the Parties with respect to the subject matter hereof and supersedes and cancels all prior representations, negotiations, commitments, undertakings, communications, either oral or written, acceptances, understandings and agreements among the Parties with respect to or in connection with any of the matters to which such Agreement applies or refers.
17. Notices to _____(**Name of Vendor**) shall be made at the following address:

(Complete Address of Vendor)

Attention: Mr. _____(**Name of the Authorised Person of Vendor**)

Notices to BHEL shall be made at the following address:

BHARAT HEAVY ELECTRICALS LIMITED,
HEAVY ELECTRICAL EQUIPMENT PLANT,
Ranipur, Haridwar-249403 (Uttarakhand), India

Attention: _____(**Name of the PPX Incharge**)

18. The effective date of this Agreement shall be the date of the last signature appearing herein.

IN WITNESS WHEREOF, each of the Parties has caused this Agreement, to be executed by its duly authorized officer.

Date :

Signed for and on behalf of

Signed for and on behalf of

(Name of Vendor)

BHEL

By:

By:

Title:

Title:

Signature:

Signature:

EXHIBIT 1

to the

NON-DISCLOSURE AGREEMENT

between

_____ **(Name of Vendor)**

and

BHARAT HEAVY ELECTRICALS LIMITED

dated:

The Non Disclosure Agreement covers the exchange of Proprietary Information which may occur during the discussions and negotiations in view of a possible cooperation between the Parties in the following programs:

-Description of Material or Services for which the order is placed

_____ **(Name of Vendor)** list of products that require an exchange of Proprietary Information which may be occur during the discussions and negotiations in view of a possible cooperation for the above programs :

EXHIBIT 2

to the

NON-DISCLOSURE AGREEMENT

between

_____ **(Name of Vendor)**

and

Bharat Heavy Electricals Ltd.

dated:

Personnel of the Parties authorized to receive and/or transmit Proprietary Information under this Agreement:

For **(Name of Vendor)**

(Name of Person)

Tel.

Fax

Address.

Tel.

Fax

Address.

For Bharat Heavy Electricals Ltd.

Mr.

Tel. 01334

Fax 01334

Address. Main Administration Building

BHEL, HEEP, Haridwar

India

Mr.

Tel. 01334

Fax 01334

Address. Main Administration Building

BHEL, HEEP, Haridwar

India