



## INVITATION TO TENDER

**Ref: OPS/OS/WC/2019-20/117/016**

**Date: 23.05.2019**

**Sub:** Mechanical Contract for Dismantling of existing heater, Unloading & storage of materials, Fabrication, Erection, Testing, Painting of Heater Components and Its Auxiliaries and Providing manpower assistance for Pre-commissioning and Commissioning of Heater Package and Auxiliaries at M/s. ONGC, Navagam, Gujarat, SO No.- 4051 . Reg.

Sealed tenders are invited under **two bid system**, Techno-Commercial Bid (Part-I) and Price Bid (Part-II) from the reputed and experienced contractors with sound technical and financial capability for the subject work.

SL. No.	NAME OF THE WORK	ESTIMATE VALUE ₹	EMD ₹	WORK COMPLETION PERIOD	LAST DATE FOR RECEIPT OF TENDER
01	Mechanical Contract for Dismantling of existing heater, Unloading & storage of materials, Fabrication, Erection, Testing, Painting of Heater Components and Its Auxiliaries and Providing manpower assistance for Pre-commissioning and Commissioning of Heater Package and Auxiliaries at M/s. ONGC, Navagam, Gujarat, S.O. No - 4051	60.01 Lakhs	1,20,100*	05 Months	<b>13.06.2019</b> up to 14.00 Hrs.

**\* EMD SHALL NOT BE EXEMPTED FOR MSME/NSIC REGISTERED VENDORS.**

### **1. ELIGIBILITY CRITERIA:**

- I) Average annual turnover of the contractor duly certified by a practitioner chartered accountant during the last 3 years ending 31<sup>st</sup> March 2018 should be at least 30% of the estimated value. (i.e. ₹ 18.00 Lakhs).

Tenderer should enclose EPF, ESI, PAN, GSTIN registration no., Income tax returns for last three years (AY 2016-17, 2017-18 & 2018-19) and Profit & Loss account and Balance Sheet certified by the Practicing Chartered Accountant for the last 3 years.

- II) The Contractor should have experience of completing similar works during the last 7 years ending 30<sup>th</sup> April 2019 as given below: -

- (a) Three similar completed works costing not less than the amount equal to 40% of the estimated value (i.e. ₹ 24.00 Lakhs each)

OR

- (b) Two similar completed works costing not less than the amount equal to 50% of the estimated value. (i.e. ₹ 30.01 Lakhs each)

OR

- (c) One similar completed work costing not less than the amount equal to 80% of the estimated value. (i.e. ₹ 48.01 Lakhs)

Work orders & Job Completion Certificates from the customer shall be enclosed in support of successful and satisfactory completion of the orders.

**Note: Similar Works means Fabrication & Erection of Structural, Erection of Static / Rotary Equipments including Heavy Lifts, Fabrication, Erection, NDT, Testing of Coils/ Piping.**

- III) The works executed in the own name of the tenderer will only be considered for eligibility criteria.
- IV) Bidder to confirm the Manpower deployment schedule as per Annexure-VI and Construction machineries deployment schedule as per Annexure-VII.

## **2. BREIF DESCRIPTION OF WORK :**

Site work of Dismantling of existing heater & shifting of dismantled materials to yard as identified by the owner, unloading of incoming materials to site from trucks/lorry/trailers, handling and stacking of materials at site, erection & welding of new materials as per drawings, painting of heater as per painting schedule, testing of heater, providing manpower assistance for pre-commissioning & commissioning including all machineries, suitable capacity of cranes for erection and handling, labour, tools, tackles and consumables (Electrode, Gas, Argon etc.) whatsoever required for satisfactory completion of site works of Heater package within contractual delivery schedule as per drawings, standards & specifications and SOQR.

The various components of the Heater will be fabricated in Modular form at BHEL-HPVP shop and will be dispatched to site to minimize the quantum of the site works.

**For Dismantling of existing heater, unloading of fabricated heater modules and erection of Heater modules and components, contractor has to arrange the suitable capacity of cranes at their cost.**

The detailed scope of work is as given in the Annexure - I, Standards, Specifications, Drawings and SOQR enclosed to NIT.

## **3. LOCATION OF SITE:**

The site is located at M/s ONGC, Navagam, Ahmedabad, Gujarat (40 Km approx. from Ahmedabad near Bareja). The tenderers are advised to visit the site before submission of the tender to assess for themselves the site conditions, the entry restrictions, safety requirements, labour regulations, local conditions etc. at Desalter Plant, M/s ONGC, Navagam, Ahmedabad, Gujarat.

## **4. EARNEST MONEY DEPOSIT**

- I. The tenderer shall submit EMD for **₹1,20,100/-** (Rupees One Lakh Twenty Thousand One Hundred only) in the following forms only:
  - a) Cash Deposit as permissible under the extant Income Tax Act (before tender opening).
  - b) Electronic Fund Transfer credited in BHEL account (before tender opening).
  - c) Banker's Cheque/ Pay Order/ Demand Draft, in favour of BHEL, Visakhapatnam (along with offer)
- II. EMD by the tenderer will be forfeited as per NIT conditions, if:
  - a) After opening the tender and within the offer validity period, the tenderer revokes his tender or makes any modification in his tender which is not acceptable to BHEL.
  - b) The contractor fails to deposit the required security deposit or commence the work within the period as per LOI/ Contract.
  - c) EMD by the tenderer shall be withheld in case any action on the tenderer is envisaged under the provisions of extant %Guidelines on Suspension of business dealings with suppliers/ contractors+ and forfeited/ released based on the action as determined under these guidelines.

III. EMD given by all unsuccessful tenderers shall be refunded normally within 15 days of award of work.

IV. EMD shall not carry any interest.

V. EMD of successful tenderer will be retained as part of Security Deposit.

**Note: As per latest guidelines of BHEL, for works contracts, EMD shall not be exempted for MSME/ NSIC registered vendors for this tender.**

**5. WORK COMPLETION PERIOD:**

The entire scope of work is to be completed within **Five months** from the date of mobilization call or one month from the date of receipt of last materials at site whichever is later.

**6. LIQUIDATED DAMAGES:**

In the event of any delay in completion of work or part thereof as per the contractual completion period due to the reasons attributable to contractor, BHEL - HPVP shall have the right to impose Liquidated Damage at the rate of 0.5% of the contract value for every complete week of delay or part thereof subject to a maximum of 10% of the contract value.

**7. SECURITY DEPOSIT:**

Security Deposit shall be collected from the successful tenderer as per clause 1.10 of annexure- III

**8. INCOME TAX:**

Income tax as per statutory requirement will be deducted on each payment made to the contractor and TDS certificate will be issued to this effect.

**9. TDS ON GST:**

TDS on GST amount as per statutory requirement as applicable will be deducted on each payment made to the contractor. Present TDS on GST is 2%.

**10. PAYMENT TERMS:**

90 % progressive payment based on work done against monthly RA bills. Out of 90%, 5% against completion of all works including liquidation of check list & 5% against commissioning. Payment will be released within 30 days from the date of submission of bill.

Balance 10% on completion and acceptance of work and submission of final bill along with relevant documents as per contract and after expiry of guarantee period/defect liability period. However, this retention amount can be released on commencement of guarantee period and on submission of equivalent Performance bank guarantee valid for Defect liability period plus claim period of 3 months.

The detailed billing break-up is to be prepared and to be approved by BHEL-HPVP for submission of monthly RA bill after award of job.

**11. MODE OF PAYMENT:**

The mode of payment and measurement of work completed shall be as per relevant clauses of General Conditions of contract and Special Conditions of the contract.

Payment will be released only through RTGS/ NEFT and all documents required for the same as specified in SCC are to be submitted by contractor along with the bill.

Bills (RA/ Final Bill) to be submitted to Engineer-in-charge along with following documents:

The mode of payment and measurement of work completed shall be as per relevant clauses of General Conditions of contract and Special Conditions of the contract.

Contractor to submit **monthly RA bill** along following documents.

- a) Detailed work measurement.
- b) Copy of PF-ECR duly stamped by the designated Bank, along with a print of the digitally signed PDF data sheet of the ECR as proof of payment, each month.
- c) Copy of the online challan endorsed / stamped by the designated bank as proof of receipt of payment towards monthly contribution of ESI contribution.

**Payment will be released only through RTGS/ NEFT and all documents required for the same as specified in SCC are to be submitted by contractor along with the bill.**

### **FINAL BILL**

Final bill shall be submitted after completion of all works and material reconciliation along with following documents as specified in General Conditions of contract.

- a) Work Completion Certificate by BHEL Site In- charge.
- b) No Claim certificate by Contractor.
- c) Clearance Certificates wherever applicable viz. Clearance Certificates from Customer, various Statutory authorities like Labour Department, PF authorities, Commercial Tax Dept. etc.
- d) Indemnity Bond as per prescribed format

## **12. PRICE SCHEDULE, TAXES & DUTIES:**

- a. Prices shall be quoted in the price schedule attached to the tender for the complete scope of work.
- b. The quoted prices shall be inclusive of all applicable taxes & duties as applicable as on date of tender submission except GST. However, GST as applicable shall be payable contractor & the shall be reimbursed by BHEL on submission of proof of payment as per annexure - GST.
- c. In addition to existing taxes, any new taxes imposed by Central/ State Govt. shall be payable by the contractor and same shall be reimbursed on submission of relevant documents/proof of payment.
- d. In case, any new tax is imposed instead of existing tax, difference of the amount shall be reimbursed/ recovered on submission of documentary evidence.
- e. Any new tax is imposed by Central/ State Govt. or there is any variation in taxes after expiry of delivery / contract period, the same shall be borne by contractor only.
- f. All terms & conditions of the contract in respect of taxes & duties are subject to new taxation laws introduced time to time by Govt. and terms & conditions will deemed to be modified in accordance with the provisions of New Laws (i.e., GST)
- g. The quoted prices shall be fixed & firm without any escalation during the entire period of contract and till completion of the work.**
- h. Tenderer should quote the amounts in figures & words. It may be noted that corrections, overwriting etc. are not allowed.
- i. All rates shall be quoted in the tender format only.

**13. REVERSE AUCTION:**

BHEL reserves the right to go for Reverse Auction (RA) (Guidelines as available on [www.bhel.com](http://www.bhel.com)) instead of opening the sealed envelope price bid, submitted by the bidder. This will be decided after techno-commercial evaluation. Bidders have to give their acceptance with the offer for participation in RA. Non-acceptance to participate in RA may result in non-consideration of their bids, in case BHEL decides to go for RA.

Those bidders who have given their acceptance to participate in Reverse Auction will have to necessarily submit ~~Process~~ compliance formq(to the designated service provider) as well as ~~Online~~ sealed bidqin the Reverse Auction. Non-submission of ~~Process~~ compliance formqor ~~Online~~ sealed bidqby the agreed bidder(s) will be considered as tampering of the tender process and will invite action by BHEL as per extant guidelines for suspension of business dealings with suppliers/contractors (as available on [www.bhel.com](http://www.bhel.com)).

The bidders have to necessarily submit online sealed bid less than or equal to their envelope sealed price bid already submitted to BHEL along with the offer. The envelope sealed price bid of successful L1 bidder in RA, if conducted, shall also be opened after RA and the order will be placed on lower of the two bids (RA closing price & envelope sealed price) thus obtained. The bidder having submitted this offer specifically agrees to this condition and undertakes to execute the contract on thus awarded rates.

If it is found that L1 bidder has quoted higher in online sealed bid in comparison to envelope sealed bid for any item(s), the bidder will be issued a warning letter to this effect. However, if the same bidder again defaults on this count in any subsequent tender in the unit, it will be considered as fraud and will invite action by BHEL as per extant guidelines for suspension of business dealings with suppliers/contractors (as available on [www.bhel.com](http://www.bhel.com)).

As a reminder to the bidders, system will flash following message (in RED Color) during the course of ~~online~~ sealed bidq

**Bidders to submit online sealed bid less than or equal to their envelope sealed Price Bid already submitted to BHEL.**

**14. COMPENSATION IN CASES OF DEATH / PERMENENT INCAPACITATION OF PERSON DUE TO UNINTENDED / UNFORESEEN OCCURENCES DURING MANUFACTURING / OPERATION AND WORK AT BHEL FACTORIES / OFFICES:**

BHEL shall recover the amount of compensation paid to victim(s) by BHEL towards loss of life / permanent disability due to an accident which is attributable to the negligence of contractor, agency or firm or any of its employees as detailed below.

- a) Victim: Any person who suffers permanent disability or dies in an accident as defined below.
- b) Accident: Any death or permanent disability resulting solely and directly from any unintended and unforeseen injurious occurrence caused during the manufacturing / operation and works incidental thereto at BHEL factories / offices and precincts thereof, project execution, erection and commissioning, services, repairs and maintenance, trouble shooting, servicing, overhaul, renovation and retrofitting, trail operation, performance guarantee testing undertaken by company or during any works/during working at BHEL units/offices/townships and premises/project sites.
- c) Compensation in respect of each of the victims:
  - (i) In the event of death or permanent disability resulting from Loss of both limbs: Rs 10,00,000/- (Rs. Ten Lakhs)
  - (ii) In the event of other Permanent disability: Rs 7,00,000/- (Rs. Seven Lakhs)

- d) Permanent Displacement: A displacement that is classified as a permanent total disablement under the provision to Section 2(l) of the Employees Compensation Act, 1923.

## 15. **GENERAL:**

### 15.1 **Bidders shall confirm their acceptance to all the terms & conditions of the tender enquiry.**

Deviations to the tender conditions are not acceptable and BHEL-HPVP reserves the right to reject such offers which do not meet Technical / Commercial requirements without any / further correspondence.

Bids not accompanied with requisite EMD, late / delayed bids, incomplete / conditional offers, bids not conforming to the terms & conditions specified in the tender are liable for rejection.

15.2 BHEL reserves the right to modify or cancel or short close the tender at any stage at its discretion without assigning any reason thereof.

15.3 The bidders shall study the Tender documents and all other relevant documents in detail for understanding the scope of work involved in various items before submission of offers.

For any clarifications required on this tender document, scope of work etc., the bidders shall depute their authorized representatives to HPVP, Visakhapatnam with prior intimation to get clarifications from concerned authorities.

15.4 DGM (E&C) shall be the Officer-in-charge for herein after referred to as such in the tender.

15.5 Lowest offer need not be the rate acceptable to BHEL-HPVP. BHEL-HPVP reserves the right for negotiation with the L1 bidders or opt for Reverse Auction as per applicable guidelines.

15.6 The following documents (enclosed) shall form part of the contract including this Notice Inviting Tender.

<b>INDEX OF CONTENTS</b>			
<b>Sl. No.</b>	<b>Description Of Documents</b>	<b>Document/Drawing/ Standard/ Specification</b>	<b>Remarks</b>
1	Detailed Scope of Site Works of Feed Heater		Annexure-I
2	Schedule Of Quantities & Rates (SOQR)	Price Bid	Annexure-II
3	General Conditions of Contract (Works/ Services)		Annexure-III
4	Special Conditions Of the Contract		Annexure- IV
5	Painting Schedule		Annexure - V
6	Manpower Deployment schedule		Annexure-VI
7	Construction Machineries deployment schedule		Annexure-VII
8	Acceptance to the Tender terms & Conditions		Annexure-VIII
9	Minimum Wages As Per Central Labour Department		Annexure-IX
10	Contractor Information		Annexure-X
11	Check List		Annexure-XI

Sl. No.	Description Of Documents	Document/Drawing/ Standard/ Specification	Remarks
13	Offer forwarding letter/Tender submission letter	Form No: F-01 Rev 0	
14	Declaration by authorized signatory of bidder	Form No: F-02 Rev 0	
15	No deviation certificate	Form No: F-03 Rev 0	
16	Declaration confirming knowledge about site conditions	Form No: F-04 Rev 0	
17	Agreement	PS:MSX:F & P Rev 0	
18	Bank Guarantee		
19	Indemnity Bond	Form No: F-21 Rev 0	
20	Power of Attorney	Form No: F-25 Rev 0	
21	GA Drawing of Fired Heater	B-0-00-00-00000 Rev 00	
22	GA Drawing for Heater Area piping	0-00-001-00001 Rev 00	
23	Manufacturing Quality Plan	CQP039 Rev 1 Dt. 28.01.17 (2 Sheets)	
24	Modularization Philosophy along with Sketches (1 to 4)		
25	Specification for Electrical heat tracing of Fuel gas piping		
26	Welding document list (WDL) & Welding Procedures specifications (WPS)	3 Sheets	
27	Statutory Requirements		

**16. VALIDITY OF OFFER:**

The offer shall be valid for a period of **Six months** from the last date for tender submission.

**17. RISK PURCHASE:**

**In case the contractor fails to execute the work due to any reason, BHEL reserves the right to get the same completed through some other party at the risk & cost of the contractor and any additional expenditure incurred due to the same shall be charged to the contractor.**

**18. TENDER COLLECTION:**

Tender Documents can be downloaded from our Websites <http://hpvp.bhel.in> & <http://www.bhel.com/tender/>.

**19. TENDER SUBMISSION:**

19.1 The Bid shall be submitted in two parts.

**Part-I: Techno-Commercial Bid shall be placed in one cover** along with the following documents:

- a. All pages of tender document after duly signed & stamped
- b. Earnest Money Deposit @ **1,20,100/-**
- c. Income tax returns for last 3 year, Profit & Loss account and Balance Sheet certified by the Practicing Chartered Accountant for the last 3 years
- d. Copy of P.F. Registration Certificate.
- e. Copy of E.S.I Registration Certificate.

- f. Experience Certificates in line with eligibility criteria
- g. Copy of GSTIN Registration Certificate.
- h. Copy of PAN
- i. All other applicable documents as detailed in the tender

**Part-II: Price Bid** in the prescribed format shall be placed in **another separate cover**.

The tender documents including the various supporting documents enclosed by the bidder should be **signed on all pages with seal**.

Both covers containing Part- I & Part- II bids shall be placed in **another** bigger size envelope duly superscribing the **Tender No. & Subject** on the envelope.

- 19.2 The tender completed in all respects **shall be dropped** in the **Outsourcing** tender box kept at reception counter, ADM building **latest by 14.00 Hrs. on 13.06.2019**.

Bidder may also send their offers by Post to "**Outsourcing Tender Box, Admn. Building, BHEL - HPVP, Visakhapatnam – 530012**".

Last date for receipt of tenders is **13.06.2019 up to 14.00 hrs**. BHEL-HPVP is not responsible for any postal or other delays in submission of offers.

Offers received in any other form will not be accepted.

- 19.3 Submission of offer by a tenderer implies that all the tender documents were read by the tenderer and the tenderer is aware of the scope and specifications of the work, site condition, local conditions and rates at which stores, tools and plant, free / chargeable materials etc., will be issued to him by BHEL - HPVP and other factors having bearing on the execution of the work.

## **20. OPENING OF TENDERS:**

Techno-commercial Bids will be opened on **13.06.2019 at 14.00 Hrs.** at Customer Cell, Admn. Building, BHEL- HPVP. The bidders may depute their representatives at the time of opening. The price bid of the techno-commercially qualified bidders will also be opened in the presence of representatives of the bidders and the date & time of opening of price bids will be intimated later. In case of reverse auction, the date of conducting reverse auction will be intimated in advance at appropriate time.

**If bids are not accompanied by requisite EMD along with Part- I (Techno Commercial Bid), then Part-II (Price Bid) will not be considered for opening.**

21. For this procurement, Public Procurement (Preference to Make in India), Order 2017 dated 15.06.2017 & 28.05.2018 and subsequent orders issued by the respective Nodal Ministry shall be applicable even if issued after issue of this NIT but before finalization of contract / POWO against this NIT

In the event of any Nodal Ministry prescribing higher or lower percentage of purchase preference and / or local content in respect of this procurement, same shall be applicable.

Yours Faithfully,  
For BHARAT HEAVY ELECTRICALS LIMITED,

*N. Satish Kumar*  
23/05/2019  
Dy. Manager (OS) SATISH KUMAR  
एचपीवीपी, बीएचईएल/HPVP-BHEL  
विशाखपट्टणम/Visakhapatnam-530012

**DETAILED SCOPE OF SITE WORKS OF FEED HEATER****I. PART A (Technical):**

**The job involves dismantling of the existing Heater and installation/ erection of new heater in the same location as per the drawings, specifications, other documents enclosed in the Tender.**

Dismantling of old Heater and transporting the dismantled materials to a location within the Desalter plant premises as per the direction of ONGC, Nawagam, Ahmedabad and making the heater location ready for erection of new heater.

The New feed heater is rectangular in shape, to be erected/installed in the Desalter plant of ONGC Nawagam. It has basically two sections a) Radiant section b) Convection section. The height of the heater up to top of stack is 18 meters. Radiant section will be installed on fabricated structure grouted on the foundation. Convection section will be installed above the radiant section with fabricated structural supports. Finally, the stack will be erected on the convection section. All the heater components shall be fabricated in BHEL-HPVP shop and supplied to site as modules /segments. All bought out components shall be dispatched to site directly from vendor's works. Contractor has to carry out the erection of these components at site as per drawings, standard and specifications.

The heater platforms ladders, staircase and handrails are also to be despatched to site in pre-fabricated conditions and erection and welding of these items are to be carried out by the contractor. Any mismatch or fabrication of small component including cutting, drilling, welding, painting etc. are to be done at site by the contractor. The contractor has to erect the stack on the top of Heater along with Ladders and platforms.

There is a FD Fan which is connected to feed Heater by piping. The pipes will be supplied to the contractor in running meter. Fabrication, erection and welding of Air piping including supporting arrangement are to be carried out by the contractor at site. The contractor to carry out the erection, alignment and pre-commissioning of FD Fan with motor.

Fuel Gas piping and other piping materials will be despatched to site in running meter along with pipe fittings. Contract to carry out the fabrication, erection, welding, NDT etc., as per drawing at site

The size and approximate weight of various sections are as below:

	ITEM DESCRIPTION	SIZE	APPROX. WT.
1.0	Radiant section	8114 x 2682 x4469	55 MT
2.0	Convection section	8114 x 4282 x 1318	33 MT
3.0	Flue gas ducts / Stack		04 MT

The General arrangement drawings may be referred with respect to above to have a clear understanding of the work involved.

- a) GA Drawing of Fired Heater - B-0-00-00-00000 Rev 00
- b) GA Drawing for Heater Area piping 0-00-001-U0092 Rev 00
- c) Modularization Philosophy along with Sketches (1 to 4)

**DETAILED SCOPE OF SITE WORKS OF FEED HEATER****THE SECTION WISE DETAILS OF HEATER:****1.0 RADIANT SECTION:**

Radiant section including casing along with coil assembly will be fabricated at HPVP and will be dispatched to site in one Module along with supporting Columns, Bottom plate and Arch plate duly assembled and welded. All the coil work inside the Radiant section will be fabricated & tested at HPVP. The radiant section will be totally lined with insulation along with fixing of Sight doors, observation doors, and access doors.

Unloading of Radiant Module, stacking at site and transportation of the same from storage area to erection site, erection in position, alignment, supporting, welding as per AFC drawings, Specifications and Standards, QAP etc., are to be carried out by contractor.

All the requisite temporary staging/ scaffolding required for the erection, alignment, welding are to be arranged by the contractor.

The stems of Skin thermocouples as per SOQR are to be welded on the radiant coil and NDT to be carried out.

The supporting structure for convection section will be assembled and welded to the radiant section and will form integrated portion of the radiant section.

The cross-over/ jump-over piping connecting the Radiant coils & convection coils and outlet header will be fabricated, welded and NDT carried out & Tested at BHEL HPVP and sent to site in **prefabricated spools**. Erection of fabricated piping spools, alignment, welding and 100% Radiography etc., are to be carried out by contractor at site. Erection of piping supports etc. as per AFC drawings, Specifications and Standards are to be carried out at site.

Fixing of tube seals is to be done as per specifications and Standards for all coil parts coming out of furnace shell through sleeves. Other items like nozzles, pressure gauges etc., shall be erected & assembled.

**2.0 CONVECTION SECTION (Economiser):**

Convection section in one Module will be dispatched to site in fabricated condition along with supporting Columns, breeching plate duly assembled and welded. All the coil work inside the Convection section will be fabricated & tested at HPVP. The Convection section will be totally lined with insulation along with fixing of observation doors, and access doors.

Also the tapping points like PT & TE, observation doors will be assembled and welded to the convection module.

Unloading, proper stacking, transporting from storage area to erection site, erection of Module as per AFC drawings, Specifications and Standards is in scope of contractor.

Erection, welding, all NDT applicable and 100% radiography required for all cross over / Jump over piping, fittings, sleeves (CS & SS), valves & flanges for instruments and auxiliary connection as per AFC drawings, Specifications and Standards are in the scope of contractor.

**3.0 SUPPORTING STRUCTURE FOR RADIANT SECTION:**

The supporting structure will be sent in prefabricated condition which are to be unloaded, stacked, properly stored, transported from storage area to site, erected, assembled, aligned and grouted on the foundation by the contractor as per AFC drawings, Specifications and Standards.

**DETAILED SCOPE OF SITE WORKS OF FEED HEATER****4.0 AIR DUCTS (FD fan out let to Burners inlet)**

These ducts are to be fabricated from pipes and pipes will be supplied to site in running meter. Fabrication and erection of Air Ducts will be done at site as per AFC drawings, Specifications and Standards by the contractor.

**5.0 PLATFORM, STAIRCASE, LADDERS, HANDRAILS, GRATINGS:**

The Operating platforms, staircase, ladders, handrails, etc., for the radiant section, convection section, will be supplied to site in **prefabricated condition** in DUs in transportable dimensions.

These structures are to be unloaded, stacked, properly stored, and transported from storage area to erection site. Erection, assembly, alignment, welding etc., are to be carried out by the contractor as per drawings, Specifications and Standards.

Electro forged Gratings will be supplied to site in loose and same are to be erected in position as per drawings.

**6.0 FLUE GAS DUCTS, STACK AND KOD:**

The flue gas ducts and Stack will be supplied in fabricated condition in sections. Erection, assembly, alignment, bolting/welding as per drawings/specifications and instructions of BHEL . HPVP is in the scope of the contractor. Similarly Knock Out Drum (KOD) will be supplied to site in fabricated conditions. Erection, alignment and grouting of foundation bolt and base plate is to be carried out by the contractor.

**7.0 PIPING:**

All piping will be supplied to site in running meter. Unloading, Stacking, proper storing, transportation of materials from storage point to work site, Fabrication, Erection, assembly, fit-up & welding, bolting, including scaffolding / staging, temporary supports etc. complete in all respects has to be carried out by the contractor. All NDT like preheating, DP, radiography etc. required as per QAP/ ITP enclosed are to be carried out by the contractor. After the installation of piping, hydro testing of the pipelines has to be carried out as per drawings / specifications and standards. Required Pumps for filling and testing are to be arranged by the contractor. Temporary gaskets for hydro testing are to be arranged by the contractor. Permanent gaskets are to be installed only after the testing and pre-commissioning activities are completed which will be supplied by BHEL.

**8.0 BOUGHT OUT COMPONENTS**

All the bought out components will be supplied by vendors directly to site. Unloading, Stacking, proper storing, transportation of materials from storage point to work site, cleaning, assembly, installation/erection, including fixing of bolts, nuts, gaskets/packing, washers, welding etc. if any, grouting, system testing, trial runs and including attending minor rectification, if any and completing the work in all respects as per drawings, specifications and instruction of BHEL - HPVP.

**9.0 BURNERS:**

Burners along with all auxiliaries will be supplied by vendor in finished condition directly to site. Unloading, stacking, proper storing, shifting from storage area to erection site, trial assembly, cleaning, Installation of the burners along with all the components including Igniters, control panels etc. complete in all respects to be carried out by the contractor as per Specifications and Standards.

**10.0 FD FAN WITH MOTORS AND ITS AUXILIARIES:**

Unloading, Stacking, proper storing, transportation of materials from storage point to work site, Erection, assembly, bolting, alignment, grouting including supply of grouting materials etc., of blowers, Motors including Local panels, in all respects as per drawings specifications & Standards and instructions of BHEL - HPVP.

**DETAILED SCOPE OF SITE WORKS OF FEED HEATER****11.0 EXPANSION BELLOWS:**

Unloading, Stacking, proper storing, transportation of materials from storage point to work site, Erection, assembly, bolting, alignment, etc., of Expansion bellows complete in all respects.

**12.0 SKIN THERMOCOUPLES:**

Unloading, Stacking, proper storing, transportation of materials from storage point to work site, Erection, assembly, welding with the coils etc., of skin thermocouples complete in all respects.

**13.0 VALVES:**

Unloading, Stacking, proper storing, transportation of materials from storage point to work site, Erection, assembly, bolting / welding with the pipelines / coils etc., of both Socket welded & Butt Welded Valves complete in all respects. Valves if required to be dropped during the pre-commissioning activities of the Pipelines are to be done and the cost of same to be included in the quoted price.

**14.0 PAINTING:**

All the fabricated components of Heater supplied to site duly painted with primer as per the approved painting schedule. Subsequent coating of painting is to be carried out by contractor as per approved Painting Schedule, Specifications and Standards. **Paints will be supplied by BHEL-HPVP as free issue.**

**15.0 LEAKAGE TESTING OF HEATER:**

To ensure leak tightness of heater casing/ducting, these shall be leak tested at site by the contractor after all mechanical works are over. The leak test shall be carried out by generating smoke (white or coloured) through Industrial smoke generator or smoke bombs. Smoke generated from fossil fuels is to be avoided. The generated smoke shall be slightly pressurized for effective testing. Contractor to ensure the availability of all equipment for the subject testing. Leak test shall be witnessed by BHEL/Owner.

**16.0** Hydro testing of heater after completion of erection, welding and NDT of cross over pi& jump over piping, inlet and outlet headers. Hydro testing of the heaters is to be carried out by using potable water / DM water. Contractor to arrange the required quantities of DM water, filling & test pump along with pressure gauges as per requirements. After Hydro test, the hydro test water is to be removed by air flushing for which contractor has to arrange required capacity of Air compressor. All temporary materials such as blind flanges, isolation valves, pressure gauges, fasteners, NRVs, gaskets etc., are to be arranged by contractor.

**17.0 PRECOMMISSIONING & COMMISSIONING ASSISTANCE:**

Contractor has to provide manpower assistance along with tools & tackles during pre-commissioning and commissioning of the Heater Package.

**18.0 DISMANTLING OF OLD HEATER:**

Dismantling of old Heater and transporting the dismantled materials to a location within the Desalter plant premises as per the direction of ONGC, Nawagam, Ahmedabad and making the heater location ready for erection of new heater. Higher capacity cranes and trailer required for dismantling & transporting of the Heater components of the existing Heater are to be deployed by contractor and cost of the same is to be included in the quoted price.

**19.0** Any other works if required as per drawings, specifications, QAP etc., for total completion of site work are to be carried out by contractor without any extra cost.

**DETAILED SCOPE OF SITE WORKS OF FEED HEATER****II. PART-B****A. CONTRACTOR' S RESPONSIBILITY:**

1. **The detailed scope of work as mentioned above from Pt. 1.0 to 20.0 and all works deemed required for the completion of the job are to be carried out by Contractor within the Quoted price.** The quantities indicated in SOQR are tentative only and may vary  $\pm$  15%. However, the rates quoted by the contractor shall be firm till the completion of job.
2. Dismantling of existing heater, transporting of dismantled materials to a location within the Desalter plant premises as per the direction of ONGC, Nawagam, Ahmedabad and making the heater location ready for erection of new heater, unloading of incoming materials from trucks/lorry/trailers, handling and stacking of materials at site, erection, painting, testing, providing manpower assistance for pre-commissioning & commissioning including supply of all construction machineries, cranes, adequate and proper workmen (skilled, semi-skilled & un-skilled), tools, tackles and consumables like Electrodes, industrial Gases, Argon, grinding wheels etc., whatsoever required for satisfactory completion of site works within the contractual delivery schedule as per drawings, standards & specifications and SOQR.
3. Since the work is to be carried out in the existing running plant, contractor to follow the prevailing safety norms in Desalter Plant, ONGC, Nawagam, Ahmedabad. The decision of ONGC's Operation personnel in this regard will be final. Contractor has to obtain all work permits viz. Hot Work permit, Cold work permit etc. daily before starting the job and during extended periods after fulfilling all the formalities as required for the same.
4. Contractor to deploy the adequate and proper manpower at site for smooth and timely completion of site works. A tentative list of manpower is given in Manpower Deployment Schedule at ANNEXURE-VI. Contractor to submit the daily manpower report to BHEL without fail. If the contractor fails to arrange the manpower as per agreement, then penalty will be levied for non-deployment of manpower as per details given below.

**Penalty for non-deployment of key personnel and key manpower per day per person after the contractual mobilisation period/ jointly agreed schedule based on front availability etc.,**

- a) **Rs.1500/- for Site In-charge**
- b) **Rs.1200/- for Site Supervisor, Quality Supervisor, Safety Supervisor,**
- c) **Rs.1000/- for Welder, Electrician**

**Notes:**

- a) **All intervening of days and holidays will be counted for levy of penalty.**
  - b) **Mobilised personnel shall not be demobilised till completion of works or based on consent of BHEL Engineer-in-Charge else penalties as above shall be applied.**
  - c) **Total of above penalties shall not exceed 5% of the contract value/executed value.**
  - d) **The above penalties are over & above all other contractual provisions with respect to penalties.**
5. Contractor to ensure the timely payment of labour wages and payments to their employees/ staff at site without linking to the payment due from BHEL. Copy of monthly wage sheets along with PF & ESI remittance details shall be submitted to BHEL every month.

**DETAILED SCOPE OF SITE WORKS OF FEED HEATER**

6. Contractor to mobilise the construction machineries as per the Construction Machinery Deployment Schedule given in ANNEXURE-VII and any other tools and tackles required for completion of the site works in all respects as per schedule.
7. Heater structure is to be erected on the already available foundations. Minor chipping and making the foundations suitable for erection if any are to be carried out by contractor. The packing plates/ Shim plates required for base plates are to be supplied by the contractor without any extra cost.
8. Grouting of heater supporting columns, Staircase structure, ladders, FD Fan & Motor foundation bolts & base frames are to be carried out by contractor including Supply of Non shrink grouting material having required compressive strength and as approved by BHEL . HPVP.
9. Structural, platforms, ladders, hand rails, gratings etc. supplied in **prefabricated condition** shall be erected & welded sequentially so as to facilitate easy erection and site convenience. Minor foundations required for the staircase structures and ladders resting on the ground are to be carried out by contractor.
10. **Suitable cranes required for dismantling of old heater, Unloading, handling, shifting, assembly, erection of new heater components and Modules are to be arranged by the contractor within the quoted rates.**

**Since the Heater components will be despatched to site in Modules as detailed above, the erection of these modules has to be carried out by contractor, suitable higher capacity cranes of adequate capacity are to be arranged for the erection of the heater modules at higher elevation by the contractor within the quoted price. To ascertain the capacity of the crane, GAD, Elevation drawings and SOQR etc., may be referred.**

**The erection scheme & the rigging procedure for the erection of the Heater components are to be submitted to BHEL-HPVP/ ONGC for review and approval prior to erection.**

**11. Construction Power:**

Customer shall provide Construction Power to the contractor free of cost at one point. Further distribution including installation of Electrical panel, cabling, main switches, ELCB accessories, energy meter etc. along with all safety devices as per standard norms prevailing at ONGC Nawagam are to be arranged by contractor at his own cost. **Supply of required cables from the allocated power point to Construction Main Panel and further to the distribution panel are to be done by contractor and cost of the same to be included in the quoted price.** Full time Qualified Electrician to be deployed by contractor and all liasioning activities required for energizing the panel and further distribution from the panel to the site are to be taken care by the contractor.

**12. Construction Water:**

Water shall be provided to the contractor at one point free of cost. Further distribution construction to work spot with necessary piping, water meters etc. as per the rules and regulations in vogue at site shall be carried out by the contractor at his own cost.

13. In special circumstances, when customer is not in a position to provide power and water, the contractor has to make his own arrangements and carry out the job without any interruption.
14. Supply & Installation of all temporary staging and scaffolding materials including pipes and clamps/ swivel couplers required for the site works of the heater are to be done by contractor and the quoted price should include the same.

**DETAILED SCOPE OF SITE WORKS OF FEED HEATER****15. INSPECTION & TESTING:**

- a. Approved QAP for the total job is enclosed in the tender. However, contractor shall prepare and submit QAP, Job procedures, WPS, PQR and ITP for all site works which are to be approved by M/s BHEL -HPVP / ONGC in line with the relevant Standards and specifications of this package. All the materials shall be inspected by M/s. BHEL - HPVP / ONGC after receipt at site as per approved ITP/ QAP & Specifications. Necessary assistance required for carrying out the Inspection has to be provided by contractor.

All the Site works shall be inspected stage wise and in Final stage by M/s. BHEL - HPVP / ONGC as per approved QAP / ITP & as mentioned in the Specifications and Standards. All Necessary assistance required for carrying out the Inspection has to be provided by contractor.

The site works should conform to the allowances mentioned in the relevant specifications and standards. Any rework / repairs resulting against the same are to be carried out by the contractor without any cost implications to the satisfaction of BHEL-HPVP/ ONGC.

- b. The welders deployed for the structural works and piping works are to be Qualified as per approved WPS and PQR. All the necessary tests required for the qualification of Welders are to be carried out by contractor.
- c. The welding consumables CS & SS required for welding of all components of heaters are to be supplied by the contractor within the quoted rate and are to be procured from BHEL . HPVP/ ONGC approved vendors along with relevant Manufacturer test certificates. Tentative List of the electrodes to be used for the job is enclosed in tender.
- d. PMI, if applicable, is to be carried out for the site weld joints as per specifications and standards.
- e. All NDT (Liquid Penetrant Test, Preheating, MPT, UT, Radiography, PWHT etc.) as applicable are to be carried out by contractor. The job procedures & Inspection test plans (ITP) for the same are to be prepared in line with Specifications / Standards and are to be submitted by contractor for approval by BHEL- HPVP/ ONGC.
- f. Hydro testing, air purging and boxing up of heater are to be carried out by contractor.
- g. Leak test of complete heater by conducting ~~Smoke test~~ as per specifications & Standards.
- h. Application of Final coats of painting as per the painting schedule is in scope of contractor.
16. Contractor shall arrange Insurance as may be required under law for all his employees and workmen/ labour engaged by him.
17. **The contractor has to obtain labour license before commencement of site works as per the Labour Act.** However, FORM-V will be issued by ONGC for the labour license. All liaisoning activities required for obtaining labour license from Labour Dept. to be done by contractor. It is the contractor's responsibility to maintain the required documentation as per labour act and same will be submitted to BHEL/ Owner for their verification.
18. The contractor shall fulfill all statutory obligations with regard to **Employee Provident Fund (EPF) & ESI** in respect of his employees and labour / workmen engaged by them and should submit proof to site In-charge / Resident Manager of BHEL - HPVP for the latest payments made to the concerned statutory authority along with each Running Account Bill.

The contractor shall be required to submit the following documents/details.

**DETAILED SCOPE OF SITE WORKS OF FEED HEATER**

- a) Copy of PF-ECR duly stamped by the designated Bank, along with a print of the digitally signed PDF data sheet of the ECR as proof of payment, each month.
  - b) Copy of the online challan endorsed / stamped by the designated bank as proof of receipt of payment towards monthly contribution of ESI contribution.
  - c) Copy of Return of contribution in respect of ESI for each contribution period of the six months i.e., for the contribution period ended 30<sup>th</sup> Sept and the contribution period ended 31<sup>st</sup> March.
  - d) Contractor shall also ensure that all statutory obligations such as Labour License, ESI, and PF etc. are complied with as long as they work with BHEL-HPVP in ONGC premises.
19. Since the heater is in the operating unit inside refinery, Contractor has to obtain all work permits viz. Hot Work permit, Cold work permits etc. daily before start of the job and all the formalities required to obtain the same are fulfilled by the contractor.

**20. SITE OFFICE / STORES SHED:**

Contractor to make his own arrangements for temporary shed for office & stores for his machinery, tools & tackles etc.

In addition to the above Contractor has to make covered store for storing small items like Pipe fittings, flanges, bends, fasteners, gaskets, valves, instruments, electrical items etc. However, all the raw material & BOC $\phi$  will be stored in open storage yard with proper stacking as per the instruction of BHEL-HPVP Resident Engineer.

All the Raw Materials, Bought out components and other materials will be handed over to contractor as and when they are received at site and are to be acknowledged as per packing list. Small items like Pipe fittings, flanges, bends, fasteners, gaskets, valves, instruments, electrical items etc., shall be stored in covered storage.

21. Contractor has to arrange for Gate Entry for manpower and all the incoming materials to site for execution of site work and all the formalities and liasioning activities with CISF / ONGC are to be taken care by the contractor at his own cost.

Unloading of the materials from the Trucks / Trailers carrying the above materials to the site is to be done in the shortest possible time and delay / detention of the same, if attributable to contractor, will be charged to his account. Contractor has to deploy exclusive dedicated staff to take care of all the above activities.

22. Contractor has to provide one exclusive helper for BHEL Office at site to work as office boy till completion site work as per SOQR.
23. For issue of Gate passes for entry inside the ONGC premises, all the employees and labour engaged by the Contractor have to produce Police Verification certificate (PVC) from the police station where they hail from and same is to be submitted to Local police authorities for issue of PVC. Similarly, Photo Identity card for all the employees and workmen engaged by contractor are required for gate pass. Without PVC and Photo Identity card, Gate passes for entry inside the ONGC premises will not be issued.
24. Contractor shall arrange for the necessary transport, medical, accommodation and other facilities for his employees, staff and labour at his own cost and abide by all labour laws, Safety codes and statutory regulations and keep owner indemnified in respect thereof.

Rest room with necessary facilities required for the Labour deployed as per the labour rules & regulations is to be established at site.

**DETAILED SCOPE OF SITE WORKS OF FEED HEATER**

25. All welding consumables (CS & SS) required for welding of all components of heater are to be supplied by the contractor within the quoted rate and are to be procured from BHEL approved vendors along with relevant test certificates. BTCs for welding consumables are to be produced for certification before putting them into use. If required, the tests for chemical composition of the welding consumables are to be carried out at site and are to be tested in approved labs.
26. All expenses towards mobilization & demobilization including bringing in equipment, clearing the site etc., shall be deemed to be included in the prices quoted and no separate payments on account of such expenses shall be entertained.
27. It shall be entirely the contractor's responsibility to provide, operate and maintain all necessary construction equipment /machineries, scaffoldings and safety gadgets, cranes and other lifting tools & tackles, and appliances to perform the work in a workman like and efficient manner and complete all the jobs as per time schedule.
28. Proper approaches and Hard stand if required for the movement and operation of the cranes, grading of the areas for assembly and erection shall also be the responsibility of the contractor.
29. Contractor has to arrange sufficient quantities of Scaffolding materials, temporary Gratings, Jallies etc. for making safe working platforms as the jobs are to be carried out at different elevations. These scaffolding materials should meet the Safety requirements / specifications of ONGC prevalent at site.

**B. BHEL-HPVP SCOPE:**

1. All the permanent materials will be supplied by BHEL- HPVP.
2. All AFC drawings, Specifications, Standards and approved QAP for total job will be furnished by BHEL-HPVP.
3. Supply of Finish paints.

**III. PART – C (COMMERCIAL)****1.0 PRICE:**

Tenderer shall quote his best competitive price for the subject work detailed in Annexure-I, Standard & specifications and drawings in the pro-forma %SCHEDULE OF QUANTITIES AND RATES+ (SOQR) enclosed at **Annexure – II A & Annexure-II B**. **Prices shall be inclusive of all taxes and duties except for GST. GST shall be payable by contractor & the same shall be reimbursed by BHEL against proof of payment as per annexure-GST.**

**2.0 TERMS OF PAYMENT:**

**90 %** progressive payment based on work done against monthly RA bills. Out of 90%, 5% against completion of all works including liquidation of check list & 5% against commissioning. Payment will be released within 30 days from the date of submission of bill.

Balance **10 %** on completion and acceptance of work and submission of final bill along with relevant documents as per contract and after expiry of guarantee period/defect liability period. However, this retention amount can be released on commencement of guarantee period and on submission of equivalent Performance bank guarantee valid for Defect liability period plus claim period of 3 months.

The detailed billing break-up is to be prepared and to be approved by BHEL-HPVP for submission of monthly RA bill after award of job.

**DETAILED SCOPE OF SITE WORKS OF FEED HEATER****3.0 Mode of payment:**

The mode of payment and measurement of work completed shall be as per relevant clauses of General Conditions of contract and Special Conditions of the contract.

Contractor to submit **monthly RA bill** along following documents.

- a) Detailed work measurement.
- b) Copy of PF-ECR duly stamped by the designated Bank, along with a print of the digitally signed PDF data sheet of the ECR as proof of payment, each month.
- c) Copy of the online challan endorsed / stamped by the designated bank as proof of receipt of payment towards monthly contribution of ESI contribution.

**Payment will be released only through RTGS/ NEFT and all documents required for the same as specified in SCC are to be submitted by contractor along with the bill.**

**FINAL BILL**

Final bill shall be submitted after completion of all works and material reconciliation along with following documents as specified in General Conditions of contract.

- a) Work Completion Certificate by BHEL Site In- charge.
- b) No Claim certificate by Contractor.
- c) Clearance Certificates wherever applicable viz. Clearance Certificates from Customer, various Statutory authorities like Labour Department, PF authorities, Commercial Tax Dept. etc.
- d) Indemnity Bond as per prescribed format.

**4.0 TAXES AND DUTIES:**

The price shall be inclusive of all taxes applicable on works, on construction equipment, machinery tools & tackles, but excluding GST there on. GST shall be reimbursed against proof of payment and submission of documents as per prevailing act as per annexure . GST. If contractor fails to pay the required taxes, BHEL- HPVP will recover the same from the contractor bills.

**5.0 LAW GOVERNING CONTRACT AND COURT JURISDICTION:**

The contract shall be governed by the law in force in the Republic of India. The Civil court having original civil jurisdiction at Visakhapatnam for HPVP shall alone have exclusive jurisdiction in regard to all claims in respect of the contract. No other civil court shall have jurisdiction in case of any dispute under this contract.

**6.0 MATERIAL ACCOUNTING:**

The contractor shall fully account all the free issue materials and submit the material reconciliation statement which will be verified and certified by Resident Engineer, BHEL-HPVP. The store clearance has to be taken by the contractor and to be submitted along with final bill for processing final bill.

The surplus materials as well as the scrap after the material accounting shall be returned to BHEL by the contractor.

**7.0 PERFORMANCE GUARANTEE:**

The contractor will be responsible for quality of the workmanship and shall guarantee the work done for a period of 18 (Eighteen) months from the date of mechanical completion or 12 (Twelve) months from the date of commissioning whichever is earlier.

**DETAILED SCOPE OF SITE WORKS OF FEED HEATER****8.0 LIQUIDATED DAMAGES:**

In the event of any delay in completion of work or part thereof as per the contractual completion period due to the reasons attributable to contractor, BHEL - HPVP shall have the right to impose Liquidated Damage at the rate of **0.5%** of the contract value for every complete week of delay or part thereof subject to a maximum of **10 %** of the contract value.

**9.0 OVER RUN COMPENSATION (ORC) /IDLE CHARGES:**

The contractor shall not be entitled to claim and the company shall not be liable to pay any amount on account of overrun compensation and idle charges, the overrun/ idling may be for whatsoever reasons.

**10.0 PRICE VARIATION COMPENSATION (PVC):**

The contractor shall be paid only at contract rate/ rates for the work executed and the contractor shall not be entitled to claim or receive any extra amount on account of any price escalations either in materials, labor, taxes / duties etc., or for any reasons whatsoever and the contract rates are firm and fixed till the completion of the work in all respects.

**11.0 PATENTS:**

M/s BHEL - HPVP warrant on their part that any design instructions given by BHEL-HPVP shall not be such, as will cause contractor to infringe any letters of patents, registered designs, trademarks, copy right or other protected right valid in India the performance of work. Subject to this, contractor has to indemnify BHEL-HPVP against any claim for infringement by Contractor or any letters of patent, registered designs, registered trademarks or copy right or other protected right valid in India in performance of contract.

**12.0 SECRECY:**

All the drawings, designs, specifications and other documents and information contained herein and any instruction given by BHEL-HPVP in the performance of contract, whether parenthetic or pardonable or not shall always remain the exclusive property of M/s BHEL - HPVP and contractor at no time shall question or dispute such right of M/s BHEL - HPVP. Such documents are given on loan by M/s BHEL - HPVP to contractor for the limited purpose of execution of work and shall be returned to M/s BHEL - HPVP in whole on completion of work. Contractor shall not publish or cause to be published any information on project, contract work covered by contract or contractor's participation in it without the prior written concerned of M/s BHEL - HPVP. The provisions of this article shall survive expiry or earlier termination/ suspension of contract.

**13.0 SAFETY:**

Contractor shall adhere to safe construction practices and shall comply with the safety rules of M/s BHEL - HPVP / ONGC in vogue at site and as per HSE & OHSAS in Chapter IX of Special Conditions of Contract.

- a) Qualified Safety Engineer approved by BHEL-HPVP/ ONGC has to be deployed exclusively by the contractor. Non- Deployment of Safety Engineer will attract penalty as applicable per day as decided by the Site-in-charge.
- b) Contractor and his employees shall follow all fire and safety, security regulations of customer.
- c) Before starting any work contractor shall apply & obtain well in advance not less than a day safety permit/hot permit etc., for execution of work. Liasioning with BHEL-HPVP ONGC for obtaining the above permits is to be taken care by contractor. Firemen has to be deployed during the execution of the works throughout the period during

**DETAILED SCOPE OF SITE WORKS OF FEED HEATER**

- d) All the safety gears required for the employees of the contractor to execute the work should be provided by the contractor within his quoted rates. The tentative list of such items but not limited to as listed under.
- i) Safety Helmets, Safety Belts, Safety Shoes, Safety gloves etc.
  - ii) Welders Gloves, Apron etc.
  - iii) Gas cutters Goggles, Grinders mask etc.
  - iv) Safety Cloths when needed.
  - v) Electrical safety devices etc.
- e) During the fabrication & erection, the contractor at all times shall keep the work and storage area free from accumulation of waste materials, rubbish etc.
- f) The contractor shall do necessary housekeeping to keep the area free of scrap materials, Electrode butts etc.
- g) Contractor has to deploy an exclusive vehicle as **AMBULANCE** to cater to any emergency requirements during the execution of site works. Penalty, as applicable, will be levied towards Non-deployment of the same.

**14.0 SITE ORGANISATION:**

The Contractor shall deploy qualified and experienced Engineers for execution of site works. However, deployment of one Qualified Resident Engineer / Site-in-charge to organize all the site activities, One Lead Engineer, One qualified quality engineer, One planning engineer and one Qualified Safety Engineer exclusively for the job along with all supporting engineers / Supervisors is mandatory.

Also contractor has to deploy all necessary skilled / semiskilled / unskilled labour including highly skilled workmen.

All responsibilities of the contractor towards Labour, Supervisory staff etc., as mentioned in Special Conditions and General Conditions of the Contract are to be strictly complied with.

**15.0 SITE MOBILISATION:**

The contractor has to commence the work as per time indicated in Letter of Intent from BHEL and shall proceed with the same with due expedition without delay.

**16.0 PLANNING & EXECUTION:**

The contractor should submit each item wise schedule to complete in the stipulated time in the form of PERT chart / MS Project to complete all the activities along with Resource mobilization indicating category wise manpower and machinery deployment in different phases of the Project.

The contractor has to prepare Monthly Plan, Weekly Plan, Daily plan as per the mutually decided and approved Overall Construction schedule and shall submit Daily reports, Weekly Reports & Monthly Reports based on the plans as per formats approved by BHEL-HPVP/ EIL.

- 17.0** The contractor has to liaison with local unions / local bodies during engagement of labourers and all necessary norms / regulations prevalent in ONGC site for engaging the local labour has to be adhered to.

**18.0 EXTRA WORKS**

- 18.1 All rectifications/modifications, revamping, and reworks required for any reasons not due to the fault of the contractor, or needed due to any change in deviation from drawings and design of

**DETAILED SCOPE OF SITE WORKS OF FEED HEATER**

equipments, operation/maintenance requirements, mismatching, or due to damages in transit, storage and erection/commissioning, and other allied works which are not very specifically indicated in the drawings, but are found essential for satisfactory completion of the work, will be considered as extra works.

- 18.2 Extra works arising on account of the contractor's fault, irrespective of time consumed in rectification of the damage/loss, will have to be carried out by the contractor free of cost. Under such circumstances, any material and consumable required for this purpose will also have to be arranged by the contractor at his cost.
- 18.3 All the extra work should be carried out by a separately identifiable gang, without affecting routine activities. Daily log sheets in the pro-forma prescribed by BHEL should be maintained and shall be signed by the contractor's representative and BHEL engineer. No claim for extra work will be considered/entertained in the absence of the said supporting documents i.e. daily log sheets. Signing of log sheets by BHEL engineer does not necessarily mean the acceptance of such works as extra works.
- 18.4 BHEL retains the right to award or not to award any of the major repair/rework/modification/rectification/fabrication works to the contractor, at their discretion without assigning any reason for the same. After eligibility of extra works is established and finally accepted by BHEL engineer/designer, payment will be released on competent authority's approval at the following rate.
- 18.5 MAN-HOUR RATE FOR ELIGIBLE EXTRA WORKS: Contractor to submit Single composite average labour man-hour rate, including overtime if any, supervision, use of tools and tackles and other site expenses and incidentals, consumables for carrying out any major rework/repairs/rectification/modification/fabrication as certified by site as may arise during the course of erection, testing, commissioning or extra works arising out of transit, storage and erection damages as per pro-forma SOQR, ANNEXURE-II/B. The man-hour rate of successful bidder will be operated for extra works at the discretion of BHEL-HPVP.
- 18.6 The above composite labour man hour rate towards extra works shall remain firm and not subject to any variation during execution of the work.**

\*\*\*\*\*

Ref: OPS/OS/WC/2019-20/117/016

Date: 23.05.2019

## **PART – II (PRICE BID)**

**Sub:** Mechanical Contract for Dismantling of existing heater, Unloading, Fabrication, Erection, Testing, Painting of Heater Components and Its Auxiliaries and Providing Assistance for Pre-commissioning and Commissioning of Heater Package and Auxiliaries at M/s. ONGC, Navagam, Gujarat, SO No.-4051

**Tender Enquiry No :** OPS/OS/WC/2019-20/117/016, Date: 23.05.2019

**Note:**

- 1 The various activities/items mentioned in the SOQR are not exhaustive. Any other activities which may be required to complete the job in all respects even if not mentioned in SOQR description shall be deemed to have been included in the total quoted prices & no extra payment for these items shall be made under any circumstances.
- 2 Unit rates for various items shall include loading, transportation, unloading, fabrication, erection, surface preparation, painting including consumables & any wastages etc.
- 3 The quantities indicated in SOQ/SOQR are tentative only and may vary +/- 15%. However, the rates quoted by the contractor shall be firm & fixed irrespective of any variation in the individual quantities and valid till completion of all works covered under this contract. No cost escalation will be paid on any account throughout the contract period for any item. Payment will be made based on actual quantities executed at site.
- 4 The quoted prices shall be inclusive of all applicable taxes & duties as applicable as on date of tender submission except GST. However, GST as applicable shall be payable contractor & the shall be reimbursed by BHEL on submission of proof of payment as per annexure - GST.
- 5 The quoted prices shall be fixed & firm without any escalation during the entire period of contract and till completion of the work.
- 6 No over run charges and escalation shall be paid to the contractor under any circumstances.
- 7 Suitable cranes required for Unloading, material handling, shifting, assembly, fit-up and welding of column segments are to be deployed by the contractor within the quoted rates during entire tenure of the project.
- 8 L1 shall be evaluated on the quoted total amount. However, BHEL reserves the right to negotiate with L1 vendor or go for Reverse Auction.
- 9 Offered discount / increase will be considered for calculation of unit rate & total amount for each item.

**ANNEXURE - II / A**

Tender Enquiry No : OPS/OS/WC/2019-20/117/016, Date: 23.05.2019

**SCHEDULE OF QUANTITIES & RATES (SOQR) - PRICE BID**

ITEM No.	ITEM DESCRIPTION	UOM	Qty	Unit Rate in ₹	Amount in ₹
1	<p>Receipt of all materials at ONGC Nawagam including arranging entry permission of vehicles at ONGC gate, liasoning with CISF for entry of vehicles with materials, unloading of raw materials, Pre-fabricated modules &amp; BOC's from trucks/trailer at site &amp; storage yard, stacking them properly. Contractor shall arrange suitable cranes/handling facilities for safe unloading of materials at designated places and provide sleepers wherever required. The materials unloaded are to be stacked properly inside the covered stores or in the open fenced areas as per directions of BHEL-HPVP Engineer, shifting of items from stores/storage yard to erection site for placing in position . All activities required for Physical verification &amp; certification of the material for preparing IMIR and release for erection by BHEL included in the scope of the item.</p> <p><b>Suitable Cranes required for the Unloading of materials and Modules are to be arranged by contractor and quoted rate should include the same.</b></p>	MT	154	1,518.00	2,33,772.00
2	<p><b>STRUCTURAL STEEL WORK :</b></p> <p>Erection of fabricated steel structures like Heater supporting columns, platform, ladders, stairways, handrails of operating platforms for radiant section, Convection section, Ducts/stack. Assembly, Aligning, bolting, fixing of prefabricated structures, alignment and grouting of the base plates with all consumables including grouting material labor supervision, tools and tackles. cleaning the surfaces and application of final coat of paint as per specification and instructions of engineer in-charge, and completing the work in all respects as per drawings, specifications and instructions of BHEL - HPVP/EIL. Finish paints to be applied after completion of job in all respects. Finish Paints will be Free Issue by BHEL.</p> <p><b>Suitable Cranes required for the erection of the structures are to be arranged by contractor and quoted rate should include the same.</b></p>	MT	15	18,894.00	2,83,410.00

Tender Enquiry No : OPS/OS/WC/2019-20/117/016, Date: 23.05.2019

## SCHEDULE OF QUANTITIES &amp; RATES (SOQR) - PRICE BID

ITEM No.	ITEM DESCRIPTION	UOM	Qty	Unit Rate in ₹	Amount in ₹
3	<p><b>PLATFORM GRATINGS:</b> Erection, fixing of GI grating &amp; welding of Electroforged gratings and stepthreads which will be supplied to site in finished condition with all consumables, labour, tools and tackles, supervision and completing the work in all respects as per drawings, specifications and instruction of BHEL - HPVP/EIL. Finish paints to be applied after completion of job in all respects. Finish Paints will be Free Issue by BHEL.</p> <p><b>Suitable Cranes required for the erection of Gratings are to be arranged by contractor and quoted rate should include the same.</b></p>	MT	5	11,494.00	57,470.00
4	<p><b>RADIANT SECTION: (Main Shell + Bottom loose structure)</b> Radiant section including coil assembly will be Fabricated at HPVP and will be despatched to site in one Module in pre-fabricated condition along with supporting Columns, Bottom plate and Arch plate duly assembled and welded. All the coil work inside the Radiant section will be fabricated &amp; tested at HO. The radiant section will be totally lined with insulation along with fixing of Sight doors, observation doors, and access doors.</p> <p>Erection / Installation of Radiant section on the structure, fixing with bolts, alignment, labour, tools and tackles, supervision and completing the work in all respects as per drawings, specifications and instruction of BHEL - HPVP/EIL. Removal of temporary structure after erection. Finish paints to be applied after completion of job in all respects. Finish Paints will be Free Issue by BHEL.</p> <p><b>Suitable Cranes required for the erection of the Radiant section to be arranged by contractor and quoted rate should include the same.</b></p>	MT	52	18,062.00	9,39,224.00
5	<p><b>PRESSURE PARTS:</b> Erection of Interconnection of Radiant coil piping with Outlet Header, Radiant coil with Convection coils &amp; Convection Coil with the Inlet Header including Fit up, Alignment, preheating, welding, NDT including DP checks, 100% radiography and repeat radiography, hydrostatic testing and any other test required for completion of coil assembly complete with spigots and installation, bolting, Gaskets, welding of auxiliary connections etc., Flushing out and blanking of the piping work, providing all labour, tools, tackles, consumables, &amp; completing the work in all respects as per drawings/ specifications and instructions of BHEL - HPVP/EIL . Finish paints to be applied after completion of job in all respects. Finish Paints will be Free Issue by BHEL.</p> <p><b><u>Suitable Cranes required for the erection of the Pressure parts are to be arranged by contractor and quoted rate should include the same.</u></b></p>				
5.1	Erection of inter connection piping, Jump over, cross-over piping. <b><u>Suitable Cranes required for the erection of the piping are to be arranged by contractor and quoted rate should include the same.</u></b>	MT	1.5	27,914.00	41,871.00
5.2	Fabrication & welding of Inter connection piping, Jump over, cross-over (Size : OD 168.3)	INCH DIA.	66	625.00	41,250.00

Tender Enquiry No : OPS/OS/WC/2019-20/117/016, Date: 23.05.2019

## SCHEDULE OF QUANTITIES &amp; RATES (SOQR) - PRICE BID

ITEM No.	ITEM DESCRIPTION	UOM	Qty	Unit Rate in ₹	Amount in ₹
6	<p><b>CONVECTION SECTION:</b> Convection section in one Module will despatched to site in fabricated condition along with supporting Columns, Breeching plate duly assembled and welded. All the coil work inside the Convection section will be fabricated &amp; tested at HO. The Convection section will be totally lined with insulation along with fixing of observation doors, and access doors. Erection/ Instalation, assembly, allignment, and providing all labour, tools, tackles, consumables, &amp; completing the work in all respects as per drawings/specifications and instructions of BHEL - HPVP/EIL. Finish paints to be applied after completion of job in all respects. Finish Paints will be Free Issue by BHEL.</p> <p><b>Suitable Cranes required for the erection of the Convection section are to be arranged by contractor and quoted rate should include the same.</b></p>	MT	31	18,062.00	5,59,922.00
7	<p><b>Hot Flue Gas Duct &amp; Stack</b> The Flue gas ducts/Stack supplied in Pre fabricated condition in Transportable sections with provision of tapping points etc. <b>(with external insulation)</b> Unloading &amp; Erection of the Flue gas ducts/Stack, assembly, alignment, bolting of Flange joints and seal welding of the flange joints providing all labour, tools, tackles, consumables, &amp; completing the work in all respects as per drawings/specifications and instructions of BHEL - HPVP/ EIL. Finish paints to be applied after completion of job in all respects. Finish Paints will be Free Issue by BHEL.</p> <p><b>Suitable Cranes required for the erection of the Ducts are to be arranged by contractor and quoted rate should include the same.</b></p>	MT	4	14,450.00	57,800.00
8	<p><b>BOUGHT OUT COMPONENTS:</b> Stacking, Proper storing,Transportation of materials from storage point to work site, cleaning, assembly, installation/erection, providing all labour, consumables, supervision, tools and tackles etc. including fixing of bolts, nuts, gaskets/packing, washers, welding etc. if any, grouting, system testing, providing skilled personnel during trial runs and including attending minor rectification, if any and completing the work in all respects as per drawings, specifications and instruction of BHEL - HPVP/ Owner.</p> <p><b>Suitable Cranes required for the erection of the BOC's are to be arranged by contractor and quoted rate should include the same.</b></p>				
8.1	<p><b>Burners:</b> Erection of Burners, Burner blocks &amp; ignition equipments including control panels and completing the work in all respects as per drawings, specifications and instructions of BHEL - HPVP/Owner.</p>	Nos	4	19,950.00	79,800.00
8.2	<p><b>BLOWERS</b> Assembly &amp; installation, alignment, grouting of BLOWER, Motor and it's control panel and pneumatic/electrical contacts etc. and completing the work in all respects as per drawings, specifications and instructions of BHEL - HPVP/Owner. Supply of grouting also in contractor scope.</p>	MT	4	28,735.00	1,14,940.00

Tender Enquiry No : OPS/OS/WC/2019-20/117/016, Date: 23.05.2019

## SCHEDULE OF QUANTITIES &amp; RATES (SOQR) - PRICE BID

ITEM No.	ITEM DESCRIPTION	UOM	Qty	Unit Rate in ₹	Amount in ₹
8.3	<b>EXPANSION BELLOWS</b> Erection, Assembly, alignment, bolting/welding etc. and completing the work in all respects as per drawings, specifications and instructions of BHEL - HPVP/Owner.	Nos	4	13,136.00	52,544.00
8.4	<b>Skin Thermocouples:</b> Erection, assembly & welding of Skin Point Thermocouples on the tube / coil surfaces including heat treatment and completing the work in all respects as per drawings, specifications and instructions of BHEL - HPVP/Owner.	Nos	2	7,342.00	14,684.00
9	<b>Valves:</b> Unloading, unpacking, transportatation to erection site, revisioning, erection in position with mating flanges in pipie lines at various elevations, welding of valves, gasket fixing, bolting etc. as per drawings and specification. Temporary spool pieces are to be fabricated , fitted wherever necessary, to facilitate blowing clean systemsand remove them after cleaning. <b>Suitable Cranes required for the erection of the Valves are to be arranged by contractor and quoted rate should include the same.</b>				
9.1	CS Valves (BW/SW) - 3/4" to 3"	Nos	40	954.00	38,160.00
9.2	CS Valves (FLANGED) - 1/2"to 3"	Nos	28	318.00	8,904.00
9.3	CS Valves (FLANGED) - 8"to 20"	Nos	8	1,696.00	13,568.00
10	<b>PIPING</b> Erection, Fit up, Alignment, preheating, welding, NDT including DP checks, radiography and repeat radiography, hydrostatic testing and any other test required for completion of piping complete, fabrication & erection of supports, bolting, Gaskets, welding of auxiliary connections etc., Flushing out and blanking of the pipe lines, providing all labour, tools, tackles, consumables, & completing the work in all respects as per drawings/specifications and instructions of BHEL - HPVP/EIL . Removal of temporary structure after erection. Finish paints to be applied after completion of job in all respects. Finish Paints will be Free Issue by BHEL. <b>Suitable Cranes required for the fabrication &amp; erection of the piping are to be arranged by contractor and quoted rate should include the same.</b>				
10.1	Fabrication of piping	Inch DIA	1,470	625.00	9,18,750.00
10.2	Erection of piping	Inch MTR	1735	271.00	4,70,185.00
11	<b>KOD of Fuel Gas line:</b> Erection, alignment, boxing up with mating flanges, fabrication & installation of supports including anchoring etc. as per drawings, specifications and instructions of BHEL - HPVP/EIL. <b>Suitable Cranes required for the fabrication &amp; erection of the piping are to be arranged by contractor and quoted rate should include the same.</b>	MT	0.5	19,076.00	9,538.00

Tender Enquiry No : OPS/OS/WC/2019-20/117/016, Date: 23.05.2019

## SCHEDULE OF QUANTITIES &amp; RATES (SOQR) - PRICE BID

ITEM No.	ITEM DESCRIPTION	UOM	Qty	Unit Rate in ₹	Amount in ₹
12	Dismantling of old Heater and transporting the dismantled materials to a location within the Desalter plant premises as per the direction of ONGC, Nawagam, Ahmedabad and making the heater location ready for erection of new heater. <b>Suitable Cranes required for the dismantling of heater components are to be arranged by contractor and quoted rate should include the same.</b>	MT	120	8,320.00	9,98,400.00
13	<b>ASSISTANCE DURING COMMISSIONING</b> Assistance during pre commissioning, commissioning by providing skilled , Unskilled manpower including all required tools & tackles, consumables etc including overtime, Sundays & Holidays (Fitter - 1 No, Rigger-2 Nos. & Helpers - 2 Nos.)	Man-days	540	1,696.00	9,15,840.00
14	Supply for office assistance	Man-days	240	630.00	1,51,200.00
	<b>Total amount in ₹</b>				<b>60,01,232.00</b>
	<b>Discount / Increase offered by Bidder on above total amount in %</b>				
	<b>Total Offered amount after Discount / Increase offered by Bidder in ₹</b>				

Total Offered amount after Discount / Increase offered by Bidder in Words:

SIGNATURE OF THE BIDDER WITH STAMP

**ANNEXURE - II / B**

**Sub:** Mechanical Contract for Dismantling of existing heater, Unloading, Fabrication, Erection, Testing, Painting of Heater Components and Its Auxiliaries and Providing Assistance for Pre-commissioning and Commissioning of Heater Package and Auxiliaries at M/s. ONGC, Navagam, Gujarat, SO No.-4051

**Tender Enquiry No :** OPS/OS/WC/2019-20/117/016, Date: 23.05.2019

<b>SCHEDULE OF QUANTITY AND RATES (SOQR) - OPTIONAL ITEMS</b>				
<b>Sl. No.</b>	<b>Description of Items</b>	<b>Unit</b>	<b>Qty.</b>	<b>Rate</b>
1	<b>MAN-HOUR RATE FOR ELIGIBLE EXTRA WORKS:</b> Contractor to submit Single composite average labour man-hour rate, including overtime if any, supervision, use of tools and tackles and other site expenses and incidentals, consumables for carrying out any major rework/ repairs/ rectification/ modification/ fabrication as certified by site as may arise during the course of erection, testing, commissioning or extra works arising out of transit, storage and erection damages.	MAN-HOUR		

**SIGNATURE OF THE TENDERER WITH SEAL**

**Bharat Heavy Electricals Limited**  
Heavy Plates & Vessels Plant, Visakhapatnam

GENERAL CONDITIONS OF CONTRACT (Works / Services)

PAGE 1 OF 30

# TABLE OF CONTENTS

## 1. CHAPTER-1: GENERAL INSTRUCTIONS TO TENDERERS

- 1.1. DESPATCH INSTRUCTIONS
- 1.2. SUBMISSION OF TENDERS
- 1.3. LANGUAGE
- 1.4. PRICE DISCREPANCY
- 1.5. QUALIFICATION OF TENDERERS
- 1.6. EVALUATION OF BIDS
- 1.7. DATA TO BE ENCLOSED
- 1.8. AUTHORISATION AND ATTESTATION
- 1.9. EARNEST MONEY DEPOSIT
- 1.10. SECURITY DEPOSIT
- 1.11. RETURN OF SECURITY DEPOSIT
- 1.12. BANK GUARANTEE
- 1.13. VALIDITY OF OFFER
- 1.14. EXECUTION OF CONTRACT AGREEMENT
- 1.15. REJECTION OF TENDER AND OTHER CONDITIONS
- 1.16. ~~EMD EXEMPTION FOR MSME VENDORS~~
- 1.17. FRAUD PREVENTION POLICY

## 2. CHAPTER-2

- 2.1. DEFINITIONS
- 2.2. HEADING OF THE CONDITIONS
- 2.3. CONTRACT DOCUMENTS
- 2.4. WORKS TO BE CARRIED OUT
- 2.5. DEVIATIONS
- 2.6. TIME
- 2.7. STORE AND MATERIALS
- 2.8. DELAY AND TIME EXTENSION
- 2.9. PATENT RIGHTS
- 2.10. TAXES AND DUTIES
- 2.11. ROYALTIES
- 2.12. PLANT
- 2.13. ASSIGNMENT OR TRANSFER OF CONTRACT
- 2.14. LAWS GOVERNING THE CONTRACT
- 2.15. COMPLIANCE TO REGULATION AND BYE LAWS
- 2.16. ORDERS UNDER THE CONTRACT
- 2.17. ADMISSION TO THE SITE:
- 2.18. CONTRACTORS SUPERVISORS
- 2.19. LABOUR LAWS TO BE COMPLIED WITH BY THE CONTRACTOR
- 2.20. ACCOMMODATION FOR LABOUR
- 2.21. ANTI MALARIAL PRECAUTION

**Bharat Heavy Electricals Limited**

Heavy Plates &amp; Vessels Plant, Visakhapatnam

GENERAL CONDITIONS OF CONTRACT (Works / Services)

PAGE 2 OF 30

- 2.22. CONSERVANCY
- 2.23. NUISANCE:
- 2.24. WATER & ELECTRICITY
- 2.25. TEMPORARY WORKSHOPS STORES etc.
- 2.26. STORES AND MATERIALS ON SITE
- 2.27. TOOLS AND PLANTS ON SITE
- 2.28. STATEMENT OF HIRE CHARGES
- 2.29. PRECAUTIONS AGAINST RISK
- 2.30. NOTICES AND FEES
- 2.31. SETTING OUT OF THE WORK & PROTECTING/ MAINTAINING SIGNALS & MARKS
- 2.32. SITE DRAINAGE
- 2.33. EXCAVATION RELICS etc.
- 2.34. FOUNDATIONS:
- 2.35. COVERING OF WORK
- 2.36. APPROVAL OF WORKS BY STAGES:
- 2.37. EXECUTION OF WORK
- 2.38. RESPONSIBILITY FOR BUILDINGS
- 2.39. INSPECTION OF WORKS
- 2.40. DAMAGE AND LOSS TO PRIVATE PROPERTY AND INJURY TO WORKS
- 2.41. COMPLETION
- 2.42. COMPENSATION AS LIQUIDATED DAMAGES FOR DELAY
- 2.43. CANCELLATION OF CONTRACT FOR CORRUPT ACTS
- 2.44. CANCELLATION OF CONTRACT DUE TO INSOLVENCY, ASSIGNMENT OR TRANSFER OR SUBLETTING OF CONTRACT
- 2.45. CANCELLATION OF CONTRACT IN PART OR IN FULL FOR CONTRACTOR'S DEFAULT
- 2.46. TERMINATION OF CONTRACT DUE TO DEATH
- 2.47. SPECIAL POWERS OF TERMINATION
- 2.48. FAIR WAGE

**3. CHAPTER-III- VALUATION AND PAYMENT**

- 3.1. RECORDS AND MEASUREMENTS
- 3.2. FINAL BILLS
- 3.3. PAYMENTS OF BILLS
- 3.4. RECOVERY FROM THE CONTRACTOR
- 3.5. POST TECHNICAL AUDIT OF WORK & BILLS
- 3.6. REFUND OF SECURITY DEPOSIT
- 3.7. ARBITRATION
- 3.8. IMPLEMENTATION OF PROVISION OF THE APPRENTICE ACT
- 3.9. SAFETY AND SECURITY

**Bharat Heavy Electricals Limited**  
Heavy Plates & Vessels Plant, Visakhapatnam

GENERAL CONDITIONS OF CONTRACT (Works / Services)

PAGE 3 OF 30

## CHAPTER -1

### GENERAL INSTRUCTION TO TENDERERS

#### 1.1. **DESPATCH\_INSTRUCTION:**

- i) The General Conditions of Contract form part of the Tender specifications. **All pages of the tender documents shall be duly signed, stamped and submitted along with the offer in token of complete acceptance thereof.** The information furnished shall be complete by itself. The tenderer is required to furnish all the details and other documents as required in the following pages.
- ii) Tenderers are advised to study all the tender documents carefully. Any submission of tender by the tenderer shall be deemed to have been done after careful study and examination of the tender documents and with the full understanding of the implications thereof. Should the tenderers have any doubt about the meaning of any portion of the Tender Specification or find discrepancies or omissions in the drawings or the tender documents issued are incomplete or shall require clarification on any of the technical aspect, the scope of work etc., they shall at once, contact the authority inviting the tender well in time (so as not to affect last date of submission) for clarification before the submission of the tender. Tenderer's request for clarifications shall be with reference to Sections and Clause numbers given in the tender documents. The specifications and terms and conditions shall be deemed to have been accepted by the tenderer in his offer. Non compliance with any of the requirements and instructions of the tender enquiry may result in the rejection of the tender.
- iii) Integrity pact (IP) shall be applicable for all tenders / contracts if indicated in NIT. This integrity pact shall be issued as part of the Tender documents and shall be returned by the bidder along with Techno-commercial bid duly filled, signed and stamped by the authorized signatory who signs the bid. Only those vendors / bidders who have entered into such an IP with BHEL shall be considered qualified to participate in the bidding. Entering into this pact shall be a preliminary qualification

#### 1.2. **SUBMISSION OF TENDERS:**

- 1.2.1 The tenderers must submit their tenders as per instructions in the NIT
- 1.2.2 Tenders submitted by post shall be sent by 'REGISTERED POST ACKNOWLEDGEMENT DUE / by COURIER' and shall be posted with due allowance for any postal/courier delays. BHEL takes no responsibility for delay, loss or non-receipt of tenders sent by post/courier. **The tenders received after the specified time of their submission are treated as 'Late Tenders' and shall not be considered under any circumstances.** Offers received by Fax/Email/Internet shall be considered as per terms of NIT.
- 1.2.3 Tenders shall be opened by authorised Officers of BHEL at the place, time and date as specified in the NIT, in the presence of such of those tenderers or their authorised representatives who may be present
- 1.2.4 Tenderers whose bids are found techno commercially qualified shall be informed the date and time of opening of the Price Bids and such Tenderers may depute their representatives to witness the opening of the price bids. BHEL's decision in this regard shall be final and binding.
- 1.2.5 Before submission of Offer, the tenderers are advised to inspect the site of work and the environments and be well acquainted with the actual working and other prevalent conditions, facilities available, position of material and labour, means of transport and access to Site, accommodation, etc. No claim will be entertained later on the grounds of lack of knowledge of any of these conditions.

**Bharat Heavy Electricals Limited**  
Heavy Plates & Vessels Plant, Visakhapatnam

GENERAL CONDITIONS OF CONTRACT (Works / Services)

PAGE 4 OF 30

**1.3. LANGUAGE:**

- 1.3.1 The tenderer shall quote the rates in English language and international numerals. These rates shall be entered in figures as well as in words. For the purpose of the tenders, the metric system of units shall be used.
- 1.3.2 All entries in the tender shall either be typed or written legibly in ink. Erasing and over-writing is not permitted and may render such tenders liable for rejection. All cancellations and insertions shall be duly attested by the tenderer.

**1.4 PRICE DISCREPANCY:**

- 1.4.1 **Conventional (Manual) Price Bid opening:** In the case of price bid opening without resorting to Reverse Auction, if there are differences between the rates given by the tenderer in words and figures or in amount worked out by him, the following procedure for evaluation and award shall be followed:

- i) When there is a difference between the rates in figures and in words, the rates which corresponds to the amounts worked out by the contractor, shall be taken as correct
- ii) When the amount of an item is not worked out by the contractor or it does not correspond with the rate written either in figure or in words, then the rate quoted by the contractor in words shall be taken as correct
- iii) When the rate quoted by the contractor in figures and words tallies but the amount is not worked out correctly, the rate quoted by the contractor shall be taken as correct and not the amount.
- iv) In case of lump sum price, if there is any difference between the amount in figures and in words, the amount quoted by the bidder in words shall be taken as correct.
- v) In case of omission in quoting any rate for one or more items, the evaluation shall be done considering the highest quoted rate obtained against the respective items by other tenderers for the subject tender. If the tenderer becomes L-1, the notional rates for the omission items shall be the lowest rates quoted for the respective items by the other tenderers against the respective omission items for the subject job and the 'Total quoted price (loaded for omissions)' shall be arrived at. However, the overall price remaining the same as quoted originally, the rates for all the items in the 'Total quoted price (loaded for omissions)' shall be reduced item wise in proportion to the ratio of 'Original' total price and the 'Total quoted price (loaded for omissions)''.
- vi) The 'Final Total Amount' shall be arrived at after considering the amounts worked out in line with 'i' to 'iv' above.

- 1.4.2 **Reverse Auction:** In case of Reverse Auction, the successful bidder shall undertake to execute the work as per overall price offered by him during the Reverse Auction process. In case of omission of rates, the procedure shall be as per 'Guidelines for Reverse Auction' enclosed.

**1.5. QUALIFICATION OF TENDERERS:**

- i) Only tenderers who have previous experience in the work of the nature and description detailed in the Notice Inviting Tender and/or tender specification are expected to quote for this work duly detailing their experience along with offer.
- ii) Offers from tenderers who do not have proven and established experience in the field shall not be considered
- iii) Offers from tenderers who are under suspension (banned) by any Unit/Region/Division of BHEL shall not be considered.

**Bharat Heavy Electricals Limited**

Heavy Plates &amp; Vessels Plant, Visakhapatnam

GENERAL CONDITIONS OF CONTRACT (Works / Services)

PAGE 5 OF 30

- iv) Offers from tenderers who do not comply with the latest guidelines of Ministry/Commissions of Govt of India shall not be considered.

**1.6. EVALUATION OF BIDS:**

- i) Techno-commercial Bids submitted by the tenderer will be opened first and evaluated for fulfilling the Pre Qualification criteria and other conditions in NIT/Tender documents, based on documentary evidences submitted along with the offer
- ii) In case the same qualifying experience is claimed by more than one agency, then the agency who has executed the work as per documentary evidence submitted shall only be qualified. Scope of qualifying work should be totally with the agency who has executed and in case it is only labour + consumables without T&P, then the responsibility of execution is assigned to the first agency and not to the agency who has executed only as labour supply contractor. Further, BHEL reserves the right to ask for further proofs including submission of TDS certificates for the said job
- iii) In case the qualifying experience is claimed by private organizations based on Work Order and completion certificates from another private organization, BHEL reserves the right to ask for further proofs including submission of TDS certificates for the said job
- iv) Assessing Bidder Capacity for executing the current tender shall be as per Notice Inviting Tender
- v) Price Bids of shortlisted bidders shall only be opened either through the conventional price bid opening or through electronic Reverse Auction, at the discretion of BHEL
- vi) Price Bids of unqualified bidders shall not be opened. After release of Letter of Intent / Work Order, the un-opened bids (including price bids) shall be returned to respective bidder along with reasons for not opening the bid.

**1.7. DATA TO BE ENCLOSED:**

Full information shall be given by the tenderer in respect of the following. Non-submission of this information may lead to rejection of the offer.

**i) INCOME TAX PERMANENT ACCOUNT NUMBER**

Certified copies of Permanent Account Numbers as allotted by Income Tax Department for the Company/Firm/Individual Partners, etc. shall be furnished along with tender.

**ii) GSTIN REGISTRATION NUMBER**

Certified copies of GSTIN Numbers for the Company/Firm/Individual Partners, etc. shall be furnished along with tender

**iii) ORGANIZATION CHART**

The organization chart of the tenderer's organization, including the names, addresses and contact information of the Directors/Partners shall be furnished along with the offer.

An attested copy of the Power of Attorney, in case the tender is signed by an individual other than the sole proprietor

**iv) IN CASE OF INDIVIDUAL TENDERER:**

His / her full name, address and place & nature of business.

**Bharat Heavy Electricals Limited**  
Heavy Plates & Vessels Plant, Visakhapatnam

GENERAL CONDITIONS OF CONTRACT (Works / Services)

PAGE 6 OF 30

**v) IN CASE OF PARTNERSHIP FIRM**

The names of all the partners and their addresses, A copy of the partnership deed/instrument of partnership duly certified by the Notary Public shall be enclosed.

**vi) IN CASE OF COMPANIES:**

- a. Date and place of registration including date of commencement certificate in case of Public Companies (certified copies of Memorandum and articles of Association are also to be furnished).
- b. Nature of business carried on by the Company and the provisions of the Memorandum relating thereof.

**1.8. AUTHORISATION AND ATTESTATION:**

Tenders shall be signed by a person duly authorized/empowered to do so. An attested copy of the Power of Attorney, in case the tender is signed by an individual other than the sole proprietor shall be submitted along with the tenders

**1.9. EARNEST MONEY DEPOSIT:**

1.9.1 Every tender must be accompanied by the prescribed amount of Earnest Money Deposit (EMD) in the manner described herein.

- a) Cash Deposit as permissible under the extant Income Tax Act (before tender opening).
- b) Electronic Fund Transfer credited in BHEL account (before tender opening).
- c) Banker's Cheque/ Pay Order/ Demand Draft, in favour of BHEL, Visakhapatnam along with offer

In case total EMD amount is more than 20 Lakh, the amount in excess of 20 lakhs may be accepted in the form of Bank Guarantee from scheduled bank. The Bank Guarantee in such cases shall be valid for at least six months.

1.9.2 EMD by the tenderer will be forfeited as per NIT conditions, if:

- a) After opening the tender and within the offer validity period, the tenderer revokes his tender or makes any modification in his tender which is not acceptable to BHEL.
- b) The contractor fails to deposit the required security deposit or commence the work within the period as per LOI/ Contract.
- c) EMD by the tenderer shall be withheld in case any action on the tenderer is envisaged under the provisions of extant "Guidelines on Suspension of business dealings with suppliers/ contractors" and forfeited/ released based on the action as determined under these guidelines.

1.9.3 EMD given by all unsuccessful tenderers shall be refunded normally within 15 days of award of work.

1.9.4 EMD shall not carry any interest.

1.9.5 EMD of successful tenderer will be retained as part of Security Deposit.

**1.10. SECURITY DEPOSIT:**

- A. Security deposit means the security provided by the contractor towards fulfillment of any obligations in terms of the provisions of the contract.
- B. The total amount of the security deposit will be **5%** of the contract value. EMD of the successful tenderer shall be converted and adjusted towards the required amount of Security deposit.

**Bharat Heavy Electricals Limited**  
Heavy Plates & Vessels Plant, Visakhapatnam

GENERAL CONDITIONS OF CONTRACT (Works / Services)

PAGE 7 OF 30

**C. Modes of Deposit:**

The balance amount to make up the required Security Deposit of **5%** of the contract value may be accepted in the following forms:

- a) Cash (as permissible under the extant Income Tax Act)
- b) Local cheques of Scheduled Banks (subject to realization)/ Pay Order/ Demand Draft/ Electronic Fund Transfer in favour of BHEL.
- c) Bank Guarantee from Scheduled Banks/ Public Financial Institutions as defined in the company's act. The bank guarantee format should have the approval of BHEL.
- d) Fixed Deposit Receipt issued by Scheduled Banks/ Public Financial Institutions as defined in the company's act (FDR should be in the name of the contractor, a/c BHEL.
- e) Securities available from Indian Post offices such as National Savings Certificates, Kisan Vikas Patras etc. (held in the name of Contractor furnishing the security and duly endorsed/ hypothecated/ pledged, as applicable, in favour of BHEL)

(**Note:** BHEL will not be liable or responsible in any manner for the collection of interest or renewal of the documents or in any other matter connected therewith)

**D. Collection of Security deposit:**

At least 50% of the required security deposit, including the EMD, should be submitted before start of the work. Balance security deposit can be collected by deducting 10% of the gross amount progressively from each of the running bills of the contractor till the total amount of the required security deposit is collected.

If the value of work done at any time exceeds the contract value, the amount of Security Deposit shall be correspondingly enhanced and the additional Security Deposit shall be immediately deposited by the Contractor or recovered from payment/s due to the Contractor.

The recoveries made from running bills (cash deduction towards balance SD amount) can be released against submission of equivalent Bank Guarantee in acceptable form, but only once, before completion of work, with the approval of the authority competent to award the work.

(Note: In case of (a) small value contracts not exceeding 20 Lakh or (b) SAS jobs, work can be started before the required Security Deposit is collected. However, payment can be released only after collection/ recovery of initial 50% Security Deposit).

- E. Security deposit shall be released to the contractor upon fulfillment of contractual obligations as per the terms of the contract.
  - F. The security deposit shall not carry any interest.
- 1.10.1 The validity of Bank Guarantees towards Security Deposit shall be initially up to the completion period as stipulated in the Letter of Intent/Award + 3 months, and the same shall be kept valid by proper renewal till the acceptance of Final Bills of the Contractor, by BHEL
  - 1.10.2 BHEL reserves the right of forfeiture of Security Deposit in addition to other claims and penalties in the event of the Contractor's failure to fulfill any of the contractual obligations or in the event of termination of contract as per terms and conditions of contract. BHEL reserves the right to set off the Security Deposit against any claims of other contracts with BHEL.

**Bharat Heavy Electricals Limited**  
Heavy Plates & Vessels Plant, Visakhapatnam

GENERAL CONDITIONS OF CONTRACT (Works / Services)

PAGE 8 OF 30

**1.11. RETURN OF SECURITY DEPOSIT:**

Security Deposit shall be refunded/Bank Guarantee(s) released to the Contractor along with the 'Final Bill' after deducting all expenses/ other amounts due to BHEL under the contract / other contracts entered into with them by BHEL.

**1.12. BANK GUARANTEE:**

Where ever Bank Guarantees are to be furnished/ submitted by the contractor, the following shall be complied with

- i) Bank Guarantees shall be from Scheduled Banks/ Public Financial Institutions as recommended by BHEL time to time.
- ii) The Bank Guarantees shall be as per prescribed formats of BHEL.
- iii) It is the responsibility of the bidder to get the Bank Guarantees revalidated/extended for the required period (subject to a minimum period of six months), as per the advice of BHEL Engineer-in-charge/ Site Engineer / Construction Manager. BHEL shall not be liable for issue of any reminders regarding expiry of the Bank Guarantees.
- iv) In case extension/further extensions of any Bank Guarantees are not required, the bidders shall ensure that the same is explicitly endorsed by the Engineer-in-charge/ Construction Manager and submitted to the BHEL Visakhapatnam.
- v) In case the Bank Guarantees are not extended before the expiry date, BHEL reserves the right to invoke the same by informing the concerned Bank in writing, without any advance notice/communication to the concerned bidder.
- vi) Bidders to note that any corrections to Bank Guarantees shall be done by the issuing Bank, only through an amendment in an appropriate non judicial stamp paper.
- vii) The Original Bank Guarantee shall be sent directly by the Bank to BHEL under Registered Post (Acknowledgement Due), addressed to the Finance Bills, BHEL, HPVP, Visakhapatnam – 530012

**1.13. VALIDITY OF OFFER:**

The rates in the Tender shall be kept open for acceptance for a minimum period of **SIX MONTHS** from latest due date of offer submission (including extension, if any). In case BHEL (Bharat Heavy Electricals Ltd) calls for negotiations, such negotiations shall not amount to cancellation or withdrawal of the original offer which shall be binding on the tenderers.

**1.14. EXECUTION OF CONTRACT AGREEMENT:**

The successful tenderer's responsibility under this contract commences from the date of issue of the Letter of Intent / Work Order by Bharat Heavy Electricals Limited. The Tenderer shall submit an unqualified acceptance to the Letter of Intent/Work order within the period stipulated therein.

The successful tenderer shall be required to execute an agreement in the prescribed form, with BHEL, within a reasonable time after the acceptance of the Letter of Intent/Work Order, and in any case before releasing the first running bill. The contract agreement shall be signed by a person duly authorized/empowered by the tenderer. The expenses for preparation of agreement document shall be borne by Contractor.

**1.15. REJECTION OF TENDER AND OTHER CONDITIONS:**

- 1.15.1 The acceptance of tender will rest with BHEL which does not bind itself to accept the lowest tender or any tender and reserves to itself full rights for the following without assigning any reasons whatsoever:

**Bharat Heavy Electricals Limited**  
Heavy Plates & Vessels Plant, Visakhapatnam

GENERAL CONDITIONS OF CONTRACT (Works / Services)

PAGE 9 OF 30

- a. To reject any or all of the tenders.
  - b. To split up the work amongst two or more tenderers as per NIT
  - c. To award the work in part if specified in NIT
  - d. In case of either of the contingencies stated in (b) and (c) above, the time for completion as stipulated in the tender shall be applicable.
- 1.15.2 Conditional tenders, unsolicited tenders, tender which are incomplete or not in the form specified or defective or have been materially altered or not in accordance with the tender conditions, specifications etc., are liable to be rejected.
- 1.15.3 Tenders are liable to be rejected in case of unsatisfactory performance of the tenderer with BHEL or tenderer under suspension (hold/banning /delisted) by any unit / region / division of BHEL or tenderers who do not comply with the latest guidelines of Ministry/ Commissions of Govt. of India. BHEL reserves the right to reject a bidder in case it is observed that they are overloaded and may not be in a position to execute this job'. The decision of BHEL will be final in this regard.
- 1.15.4 If a tenderer who is a proprietor expires after the submission of his tender or after the acceptance of his tender, BHEL may at their discretion, cancel such tender. If a partner of a firm expires after the submission of tender or after the acceptance of the tender, BHEL may then cancel such tender at their discretion, unless the firm retains its character.
- 1.15.5 BHEL will not be bound by any Power of Attorney granted by changes in the composition of the firm made subsequent to the execution of the contract. They may, however, recognise such power of Attorney and changes after obtaining proper legal advice, the cost of which will be chargeable to the contractor concerned.
- 1.15.6 If the tenderer deliberately gives wrong information in his tender, BHEL reserves the right to reject such tender at any stage or to cancel the contract if awarded and forfeit the Earnest Money/Security Deposit/any other money due.
- 1.15.7 Canvassing in any form in connection with the tenders submitted by the Tenderer shall make his offer liable to rejection.
- 1.15.8 In case the Proprietor, Partner or Director of the Company/Firm submitting the Tender, has any relative or relation employed in BHEL, the authority inviting the Tender shall be informed of the fact as per specified format, along with the Offer. Failing to do so, BHEL may, at its sole discretion, reject the tender or cancel the contract and forfeit the Earnest Money/Security Deposit.
- 1.15.9 1.15.9 The successful tenderer should not sub-contract part or complete work detailed in the tender specification undertaken by him without written permission of BHEL's Construction Manager/ Site-in-charge/ Engineer -in-charge. The tenderer is solely responsible to BHEL for the work awarded to him.
- 1.15.10 1.15.10 The Tender submitted by a techno commercially qualified tenderer shall become the property of BHEL who shall be under no obligation to return the same to the bidder. However unopened price bids and late tenders shall be returned to the bidders.
- 1.15.11 1.15.11 Unsolicited discount received after the due date and time of Bid Submission shall not be considered for evaluation. However, if the party who has submitted the unsolicited discount/rebate becomes the L-I party, then the awarded price i.e. contract value shall be worked out after considering the discount so offered.
- 1.15.12 1.15.12 BHEL shall not be liable for any expenses incurred by the bidder in the preparation of the tender irrespective of whether the tender is accepted or not.

<b>Bharat Heavy Electricals Limited</b> Heavy Plates & Vessels Plant, Visakhapatnam	
GENERAL CONDITIONS OF CONTRACT (Works / Services)	PAGE 10 OF 30

**1.16. ~~EMD EXEMPTION FOR MSME VENDORS:~~**

~~MSE suppliers can avail the intended benefits only if they submit along with the offer, attested copies of either EM II certificate in similar works having deemed validity (five years from the date of issue of acknowledgement in EM II) or valid NSIC certificate or EM II certificate along with attested copy of a CA certificate (Format enclosed at annexure A where deemed validity of EM II certificate of five years has expired) applicable for the relevant financial year (latest audited). Date to be reckoned for determining the deemed validity will be the date of bid opening (Part 1 in case of two part bid). Non-submission of such documents will lead to consideration of their bid at par with other bidders. No benefits shall be applicable for this enquiry if any deficiencies in the above required documents are not submitted before price bid opening. Documents should be notarized or attested by a Gazetted officer".~~

**1.17. FRAUD PREVENTION POLICY:**

"The bidder along with its associate/collaborators/sub-contractors/sub-vendors/consultants/ service providers shall strictly adhere to BHEL Fraud Prevention Policy displayed on BHEL website <http://www.bhel.com> and shall immediately bring to the notice of BHEL management about any fraud or suspected fraud as soon as it comes to their notice".

**Bharat Heavy Electricals Limited**

Heavy Plates &amp; Vessels Plant, Visakhapatnam

GENERAL CONDITIONS OF CONTRACT (Works / Services)

PAGE 11 OF 30

**CHAPTER-II****2.1 DEFINITIONS:**

In these general conditions of contract, the following terms shall have the meaning hereby assigned to them except where the context otherwise requires: -

- (a) The "CONTRACT" means the documents forming the tender and acceptance thereof together with all the documents referred to therein including General and Special conditions of contract, CPWD specifications Vol. I to VII as amended up to date and the drawings. All the documents as applicable taken together shall be deemed to form one contract and shall be complementary to one another.
- (b) The "TENDER DOCUMENT" means the form of tender as applicable General and Special Conditions of contract, and the specifications and/or drawings as given to contractors for the purpose of preparing their tender including "Notice Inviting Tender".
- (c) The "WORK" means the work described in the tender documents in individual work order and/ or accompanying drawings and specifications as may be issued from time to time to the contractor by the Engineer-in-charge in writing the power conferred upon them, including all modifications or additional works and obligations to be carried out either at the site or in factory, workshop or any other place as may be essentially required for the performance of the work.
- (d) The "SITE" means the land and/ or other place on into or through which the work is to be executed under the contract or any adjacent land, part or structure which may be allotted to or used for the purpose of carrying out the contract.
- (e) The "CONTRACTOR" means the individual firm or company whether incorporated or not, undertaking the work and shall include the legal personal representatives of such individuals or the person(s) composing the firm or company and the permitted assigns of such individuals or firm or company.
- (f) The abbreviations "SE/ Dy. Mgr/ Mgr./ Sr. Mgr/ DGM/ Sr. DGM/ AGM/ GM" means Senior Engineer/ Deputy Manager/ Manager/ Senior Manager/ Deputy General Manager/ Sr. Dy. General Manager / Additional General Manager / General Manager respectively who will direct the contract.
- (g) The "ENGINEER INCHARGE" means the Engineer/ Sr. Engineer or any other executive deputed by BHEL to supervise the work or part of the work on behalf of the First Party.
- (h) Accepting authority: As per BHEL Delegation of Power
- (i) "APPROVED" means the approval of directions of the Sr. Manager/ Manager/ Dy. Manager or person deputed by them for the particular purpose.  
 "Bharat Heavy Electricals Limited" hereinafter referred to as BHEL shall mean the Head of the contracting / Outsourcing department / Other Administrator or other Administrative Officers of the said Company including the Engineer-in-charge, Sr. Manager or other executive deputed by BHEL is authorized to invite tenders and enter into contract for works on behalf of the Company. BHEL means the Bharat Heavy Electricals Limited/ HPVP plant of the said Company at Visakhapatnam.
- (j) In the case of percentage rate contract, "Contractor's percentage" shall if the context so permits means the uniform percentage tendered by the contractor and accepted by the Accepting Officer and expression "Contract Rates" shall refer to rates in the Schedule of Quantities & Rates (SOQR).
- (k) The "CONTRACT SUM" means the sum accepted or the sum calculated in accordance with the prices accepted in tender and/ or the Contract rate as applicable to the contractor for the entire execution and full completion of the work.
- (l) The "FINAL SUM" means the actual amount payable under the contract by BHEL to the contractor for the entire execution and full completion of the work.
- (m) The "TIME OF COMPLETION" is the date or dates for completion of the work or any part of the work as set out in or ascertained in accordance with the individual work or the tender documents or any subsequent amendments thereto.

**Bharat Heavy Electricals Limited**

Heavy Plates &amp; Vessels Plant, Visakhapatnam

GENERAL CONDITIONS OF CONTRACT (Works / Services)

PAGE 12 OF 30

- n) A "WEEK" means seven days without regard to the number of hours worked in any day in that week.
- (o) A "DAY" means a day of 24 (twenty-four) hours irrespective of the number of hours worked or not worked in that day.
- (p) A "WORK DAY" means day other than that prescribed by the Negotiable Instruments Act, as being a holiday and consists of the number of hours of labour as commonly recognized by good employers in the trade, in the district where the work is carried out or as laid in the BHEL Rules and Regulations.
- (q) "DEVIATION ORDER" means any order given by the Engineer-in-charge to effect an alteration, addition or deduction, which does not radically affect the scope and nature of the contract.
- (r) "EMERGENCY WORK " means any urgent measures which in the opinion of the Engineer-in-charge become necessary during the progress of the work to obviate any risk of accident or failure or which become necessary for security.
- (s) "PROVISIONAL SUM" or "PROVISIONAL LUMPSUM" means a lump sum included by the BHEL in the work for which details are not available at the time of inviting tender.
- (t) "PROVISIONAL ITEMS" means items for which approximate quantities have been included in the tender documents.

**SCOPE OF WORK****2.2 HEADING OF THE CONDITIONS:**

The heading to these conditions shall not affect the interpretation thereof. The decision of BHEL regarding interpretation of any of terms and conditions set forth in this agreement shall be final and binding on the contractor

**2.3 CONTRACT DOCUMENTS:**

The accepting officer shall furnish to the contractor on demand, two copies of the signed drawings and schedule, and copies of all other relevant documents and specifications and the Engineer in- charge or his representative shall have, at all reasonable times, access to them.

**2.4 WORKS TO BE CARRIED OUT:**

The contractor shall, except as provided under schedule include all labour, materials, tools, plant, equipment & transport which may be required in preparation for, and in the entire execution and full completion of work. Schedule shall be deemed to have prepared in accordance with good practice and recognized principles & unless otherwise stated the descriptions given therein shall be held to include rate on materials, carriage, and cartage, lead, return of empties, hoisting, setting, fitting in position and all other labour necessary in and for the entire execution and full completion aforesaid. Any error in description or in quantity in schedule or any omission there from shall not vitiate the contract or release the contractor from the execution of the whole or any part of the work comprised there in accordance to the drawings and material workmanship but the articles or materials specified may be obtained from any other firm subject to the prior written approval of the Unit Head of the First Party.

In case of any discrepancy between schedule, the specification and/ or the drawings, the Accepting Officer shall be the deciding authority as to which shall prevail and his decision shall be final and conclusive. If neither drawings nor specifications contain any mention of minor details of construction, which in the opinion of the Accepting Officer are essentially as are reasonably and obviously and fairly intended for the satisfactory completion of the work, whose decision shall be final and conclusive. Such details shall be provided by the contractor without any extra cost as if they were specifically mentioned and shall be deemed to be included in the contract. The contractor shall be deemed to have satisfied himself as to the nature of site, local facilities of access and all matters affecting the execution and completion of the work. No extra charges consequent on any misunderstanding in these respects or otherwise will be allowed by the First Party.

**Bharat Heavy Electricals Limited**

Heavy Plates &amp; Vessels Plant, Visakhapatnam

GENERAL CONDITIONS OF CONTRACT (Works / Services)

PAGE 13 OF 30

**2.5 DEVIATIONS:**

The contractor shall not make any alteration and addition to or omission from the work as described in the tender documents except in pursuance of the written instructions of the Engineer Incharge. No such DEVIATION from the work described in the tender documents shall be valid unless the same has been specifically confirmed in writing.

The Accepting Officer may deviate, either by way of addition or deduction from the work so described provided that the contract sum thereby carried on the whole, by not more than the percentage set out in the tender documents. The value, of all additions and deductions will be added to or deducted from the contract sum. Whenever the Accepting Officer intends to exercise such a right, his intention shall specify the deviations, which are to be made on the lump sum assessment or the proposed basis of payment, the extra items allowed, if any, and the date for completion of entire contract. Any objection by the contractor to any matter consisting the order shall be notified by him in writing to Engineer-in-charge within seven days from the date of such order, but under no circumstance shall the work be stopped (unless so ordered by the Engineer-in-charge) owing to such difference or controversy that may arise from such an objection by the contractor. The Contractor shall be deemed to have accepted the order and the conditions stated therein. In the event of the contractor failing to agree with Engineer-in-charge regarding the terms of proposed deviation, the objection shall be referred to the Accepting Officer or officer authorized by Accepting Officer whose decision shall be binding on the contractor.

**2.6 TIME:**

Time is the essence of the contract and is specified in the tender document or in each individual work order.

As soon as possible after the contract is let or any substantial work order is placed and before the work is to begin, the Engineer-in-charge and the contractor shall (if so required by the Engineer-in-charge) agree a time and progress chart for completion of the work within the scheduled time. The chart in the work order shall have the completion date of the individual items thereof and/ or the contract or order as a whole. It shall indicate the forecast of the dates for commencement and completion of the various processes or sequences of the work, and shall be amended as may be required by agreement between Engineer-in-charge and contractor writing the limitations of time imposed in the tender document or order.

In the absence of any specific time and progress chart to be agreed to between the contractor and Engineer-in-charge, the contractor shall ensure and maintain, uninterrupted progress of the work such that the entire work shall be completed within the time imposed in the tender documents or order and the proportion of work that shall be completed up to any time in relation to the entire work to be done under the contract or order shall not be less than the proportion that the time elapsed bears to the total time of completion provided in the tender documents or order. The contractor shall suspend the execution of the work or any part or parts thereof whenever called upon in writing by the Engineer-in-charge. The contractor will be allowed an extension of time for completion limited to not less than the period of suspension but no other claim in respect for compensation or otherwise whatsoever will be admitted. Time may also be extended to allow for alteration of work made by the deviation order as may be decided upon by the Engineer-in-charge in consultation with the contractor.

**2.7 STORE AND MATERIALS:**

The contractor shall, at his own expense, supply all stores and material required for the contract other than free issue materials provided by BHEL at the rates detailed therein subject to their availability at the place of issue indicated therein. All stores and materials to be supplied by the contractor shall be of the best kind as described in the specification and the contractor shall ensure that the stores and materials so comply with the specifications. The contractor shall, at his own expense and without delay, supply samples of stores and materials proposed to be used in the execution of the work for the approval of Engineer-in-charge, who may reject all stores and materials not corresponding either in quantity or character to the approved samples. The stores and materials so rejected shall be duly replaced by the Contractor in time to ensure completion of the work as scheduled and the rejected stores/ materials shall also be replaced by him at his own cost and effort.

In case of stores and material provided by BHEL, the contractor shall bear the cost of loading, transporting to site, unloading, storing under cover and as required, assembling and jointing the several parts together as

**Bharat Heavy Electricals Limited**  
Heavy Plates & Vessels Plant, Visakhapatnam

GENERAL CONDITIONS OF CONTRACT (Works / Services)

PAGE 14 OF 30

necessary and incorporating fixing these stores and materials in the work including all preparatory work of whatever description that may be required, and returning empty cases or containers to the place of issue without any extra charge.

**2.8 DELAY AND TIME EXTENSION:**

If in the opinion of Engineer-in-charge the work is delayed by any one or more of the following:

- 1) By reason of abnormally bad weather,
- 2) By reason of serious loss or damage by fire,
- 3) By reason of civil commotion, local combination of worker, strike or lockout, affecting any of the trades employed on the work,
- 4) By delay on the part of the agency or tradesmen engaged by B.H.E.L./ HPVP in executing work not performing part of this contractor,
- 5) Earthquake & floods
- 6) Busy of nation
- 7) Riots
- 8) Non-availability of stores which are responsibility of BHEL etc. the same shall be covered under force majeure.
- 9) Any Other Reason.

By reason of any other cause, which in the absolute discretion of the Engineer-in-charge (when he is the accepting officer of the contract), is beyond the contractor control. When in such case(s) the accepting officer, on recommendation of the Engineer-in-charge (or higher authority) to be specified in this regard, may make fair and reasonable extension in the completion date of the individual items of work of the contract as a whole. Such extension, which will be communicated to the contractor by the Engineer-in-charge in writing, but shall nevertheless use constantly his best endeavour to prevent or make good the delay and shall do all that may be reasonably required to the satisfaction of the Engineer-in-charge to proceed with the work. The delay caused on this account may be waived by the Accepting Officer on merit, based on the written request of the Contractor.

**2.9 PATENT RIGHTS:**

The contractor shall fully indemnify BHEL or the agent servant or employees or BHEL against any action, claim or proceeding to infringement or the use of any patent or design or any alleged patent or design rights, and shall pay any royalties which may be payable in respect of article or part thereof included in the contract. In the event of any claims being made or action against BHEL in respect of any of the matters aforesaid, the contractor shall immediately be notified thereof for taking necessary action provided that the payment of indemnity shall not apply when such infringement has taken place, in complying with the specific direction issued by BHEL but the contractor shall pay any royalties payable in respect of any such use.

**2.10 TAXES & DUTIES:**

All charges on account of taxes and/or duties on materials obtained for the work (excluding materials provided by BHEL) shall be as per Notice of Inviting tender.

**2.11 ROYALTIES:**

Royalties fixed from time to time as per prevalent local rules will be recovered for materials, after which the contractor may be allowed to remove from quarries situated on land, which is in the charge of BHEL authorities.

**2.12 PLANT:**

The contractor, shall at his own expense, supply all tools plants and equipment (herein after referred to as T & P) required for the execution of the contract, as specified in the tender documents.

**Bharat Heavy Electricals Limited**

Heavy Plates &amp; Vessels Plant, Visakhapatnam

GENERAL CONDITIONS OF CONTRACT (Works / Services)

PAGE 15 OF 30

**2.13 ASSIGNMENT OR TRANSFER OF CONTRACT:**

The contractor shall not without prior written approval of the accepting officer, assign or transfer the contract or any part thereof or any share, or interest wherein to any other person. No sum of money which may become payable under the contract shall be payable to any person other than the contractor without prior written approval of Accepting Officer to the assignment or transfer of such money.

**SUB CONTRACT:** The contractor shall not sub-contract any portion of the contract without the prior written approval of the Accepting Officer.

**2.14 LAWS GOVERNING THE CONTRACT:**

BHEL reserves the right to take penal action as deemed fit if any information provided by the vender / contractor is found to be incorrect. This contract shall be governed by the Indian Laws for the time being in force.

**2.15 COMPLIANCE TO REGULATION AND BYE LAWS:**

The contractor shall conform to the provisions of any statute relating to the work and regulations and bye-laws of any local authority and of any water and lighting companies or undertakings with whom/whose systems the work is proposed to be connected. Before making any variation from the drawings or specifications so as to necessitate for such connections the contractor shall give notice to Engineer-in-charge specifying the variations proposed to be made and the reasons thereof. Until he has received instructions from the Engineer-in-charge in respect thereof, the contractor required shall be bound to give all notice by statute regulations or bye-laws as aforesaid and to pay all fees and taxes payable to any authority in respect thereof.

**PERFORMANCE OF THE CONTRACT****2.16 ORDERS UNDER THE CONTRACT:**

All orders, notices etc. to be given under the contract shall be in writing, typescript or printed and if sent by registered post to the address given in tender of the contractor, shall be deemed to have been on the date when in ordinary course they would have been delivered to him. The contractor shall carry out without delay all orders given to him.

**2.17 ADMISSION TO THE SITE:**

The contractor shall not enter on (other than for inspection purpose) or take possession of the site unless permitted to do so by Engineer-in-charge. The portions of the site to be occupied by the contractor shall be clearly defined and marked on the site plan, and the contractor will not on any account be allowed to extend his operations beyond these areas.

The contractor shall be provided if necessary or required at site, temporary access thereto and shall modify and maintain the same as required from time to time. He shall take out and clear away and access route when no longer required, restoring the area to its original condition. The Engineer-in-charge shall have power to execute other works whether or not connected with the work in contract agreement on the site contemporaneously with the execution of the original work and the contractor shall give reasonable facilities for this purpose.

BHEL reserves the right of taking over, at any times any portion of the site which they may require and the contractor shall at his own expense clear such portion forthwith. The photographs of the site of work or any part therein shall be taken, published or otherwise circulated with the prior approval of Engineer-in-charge.

No such approval shall, however, exempt the contractor from complying with any statutory provision in regard to the taking and publication of such photograph. No such approval shall, however, exempt the contractor or shall give him the right to entry to the site at all time. The Engineer-in-charge shall have the power to exclude from the site any person of the Contractor whose admission thereto may in his opinion be undesirable for any reason whatsoever.

**2.18 CONTRACTORS SUPERVISORS:**

The contractor shall either himself supervise the execution of the contract or shall appoint competent agent approved by the Engineer-in-charge to act in his stead.

**Bharat Heavy Electricals Limited**

Heavy Plates &amp; Vessels Plant, Visakhapatnam

GENERAL CONDITIONS OF CONTRACT (Works / Services)

PAGE 16 OF 30

The contractor shall employ such Agent having at least DEGREE of BACHELOR of Engineering from a recognized University for contract value exceeding rupees ten lacs, or having at least a diploma in engineering from a recognized college for contract value exceeding Rs.5 lacs but not exceeding Rs ten lacs. The employment of any agent as aforesaid shall not be necessary if the contractor himself is in possession of recognized technical qualification and is in opinion of the Engineer In charge, capable of receiving instructions of the Engineer-in-charge and for execution of the works to the full satisfaction of the Engineer In charge. If the contractor fails to appoint a suitable Engineer/ agent as aforesaid, the Engineer-in-charge shall have full power to suspend the execution of work and stop payment of any advance that may become due until such date till a suitable Engineer/ agent is appointed and the contractor shall be held responsible for the delay caused to the work and no extension of time on this account shall be given to him as stipulated in condition mentioned above.

Orders given to contractor's agent shall be considered to have the same force as if they had been given to the contractor himself.

The contractor or his accredited agent shall attend whenever required and without making any claim for doing so, either to the office of the Engineer-in-charge or the work site to receive instructions. The Engineer-in-charge shall have full power and without assigning any reason, to require the contractor immediately and cease to employ in connection with this contract any agent, servant or employee whose continued employment is, in his opinion, undesirable. The contractor shall not be allowed any compensation on this account.

**2.19 LABOUR LAWS TO BE COMPLIED WITH BY THE CONTRACTOR:**

The contractor shall employ labour in sufficient number to maintain the required rate of progress and of quality required to ensure workmanship of the degree required by the specifications and to the satisfaction of the Engineer-in-charge.

Contractor shall decide the number of employees to be deployed for execution of the work awarded to him and he or his authorized representative will be solely entitled to dictate such workers about the manner of carrying out the work as per the prescribed specifications and quality plan.

Contractor to ensure that the employees deployed in the premises of BHEL are physically and mentally fit and do not have any criminal record. Such employees should possess requisite skill, proficiency, qualification, experience etc. Contractor to provide employment card / identity with photograph duly verified and attested by the contractor to his employees. Contractor to indicate the name of the proprietary/ partnership firm/ company, place of work, contract no. and duration of validity of card. Contractor will be responsible for good conduct of his employees. In case of any misconduct / misbehaviour by any employee, the contractor will replace such employee(s) immediately.

BHEL shall have the privity of the contract with the contractor only and will give instructions to the contractor or his authorized representatives. BHEL will have nothing to do or be concerned with the employment of employees working for the contractor. The relationship between BHEL and the contractor will be that of independent entities and nothing herein contained will amount to joint venture, partnership or an employer employee relationship.

The contractor shall obtain a valid labour licence under the Contract Labour (R&A) Act 1970, and the Contract Labour (Regulation and Abolition) Central Rules 1971, before the commencement of the work, and continue to have a valid licence until the completion of work. The contractor shall also abide by the provisions of the Child Labour (Prohibition and Regulation) Act 1986. The relevant statutory provisions of the State Government of Andhra Pradesh shall also be applicable in toto. The contractor shall observe provisions of the Factories Act in respect of working hours, holidays, rest intervals, leaves and overtime to his employees. No work shall be done on second/ third shift, overtime, Sundays or on other declared holidays without written permission from BHEL.

Any failure to fulfil this requirement shall attract the penal provisions of the Contract arising out of the resultant non-execution of the work.

**Payment of wages:**

- I. The contractor shall pay to labour employed by him either directly or through sub-contractors, in accordance with the provisions of the Contract Labour (Regulations and Abolition) Act 1970 and the Contract Labour

**Bharat Heavy Electricals Limited**

Heavy Plates &amp; Vessels Plant, Visakhapatnam

GENERAL CONDITIONS OF CONTRACT (Works / Services)

PAGE 17 OF 30

(Regulation and Abolition) Central Rules 1971 or Minimum Wages Act wherever applicable, including the relevant statutory provisions of the State Government. The contractor shall ensure payment of wages to the Contract labour employed by him latest by 7th of the following month. The above payments shall be verified by the departmental supervisor under his name and designation.

- II. In respect of all labour directly or indirectly employed in the works for performance of the contractor's part of this contract, the Contractor shall comply with or cause to be complied with the BHEL's Contractor's Labour Regulations made by BHEL from time to time or as per the provisions of the Contract Labour (Regulations and Abolition) Act 1970 and the Contact Labour (Regulation and Abolition) Central Rules 1971 and Minimum Wages Act wherever applicable.
- III. (A) The Engineer-in-charge concerned shall have the right to deduct from the moneys due to the contractor any sum required or estimated to be required for making good the loss suffered by a worker or workforce by reason of non-fulfilment of the conditions of the contract for the benefit of the workers, non-payment of wages or of deductions made from his or their wages which are not justified by their terms of the contract or non-observance of the regulations.
- B) Under the provisions of Minimum Wages (Central) Rules 1950, the contractor is bound to allow to the labours directly or indirectly employed in the works one-day rest for 6 days continuous work and pay wages at the same rates as for duty. In the event of default, the Engineer-in-charge shall have the right to deduct the sum or sums not paid on account of wages for weekly holidays to any labour and pay the same to the persons entitled thereto from any money due to the contractor by the Engineer-in-charge concerned.
- IV. The contractor shall duly comply with the provisions of the Payment of wages Act-1936, Minimum Wages Act 1948, Employees liability Act-1938, Workmen's compensation Act-1923, Industrial Disputes Act 1947, Maternity Benefits Act 1961, EPF and MP Act 1952, Payment of Gratuity Act 1972, Income tax Act, Service Tax Act, Employees State Insurance Act, Payment of Bonus Act 1967 etc. and the Contract Labour (Regulations and Abolition) Act 1970, or the modifications thereof or any other laws relating thereto and the rules made there under from time to time.
- a) Contractor must ensure payment of PF, pension dues under EPF and MP Act 1952 to the RPFC.
  - b) Contractor must ensure payment of ESI contribution under ESI Act 1948 and provide ESI membership No. / Card of each employee.
  - c) Contractor shall produce proof of deductions as well as remittances of PF, Pension, ESI contribution; administrative charges etc. wherever applicable and shall maintain proper records. Contractor to issue wage slip to his employees.
  - d) The contractor shall furnish proper returns to the concerned statutory authorities like PF etc. and also provide a copy of the same to BHEL.
  - e) In case of non compliance of any of the labour laws e.g. payment of minimum wages to his employees or remittance of contribution to the concerned authorities etc., the contractor shall be responsible for all the expenses /liability occurring/ accruing on BHEL because of this including expenditure of legal proceedings. All such expenses shall be recoverable from the contractor from any of his running contracts / security deposit / other dues with BHEL or from any contract entered with BHEL thereafter.
  - f) Payment of bonus under the Payment of Bonus Act, payment of Gratuity under the Gratuity Act and retrenchment compensation under act will be the sole responsibility of contractor.
  - g) Contractor shall pay minimum wages as applicable from time to time including leave with wages to their workers as per rules /act.
  - h) Contractor will give three National Holidays to his workers.
- V. The contractor shall indemnify and keep BHEL indemnified against statutory payments to be made under for due observance of the laws aforesaid as well as the BHEL contractor's Labour Regulations without prejudice

**Bharat Heavy Electricals Limited**

Heavy Plates &amp; Vessels Plant, Visakhapatnam

GENERAL CONDITIONS OF CONTRACT (Works / Services)

PAGE 18 OF 30

to his rights to claim indemnity from his sub-contractors not affecting BHEL under any event or statutory violation by the contractor.

- VI. The laws aforesaid shall be deemed to be part of this contract and any breach thereof shall be deemed to be a breach of the contract.
- VII. Whatever is the minimum wage for the time being, such wage shall be paid by the contractor to the workmen directly without any intervention of jamadar and that jamadar shall not be entitled to deduct or recover any amount from the minimum wage payable to the workmen and by way of commission or otherwise.
- VIII. The contractor shall ensure that no amount by way of commission or otherwise is deducted or recovered by that jamadar from the wages of workmen engaged by him in the work premises of BHEL.
- IX. All the registers and records shall be preserved in original for a period of 3 years from the passing of final bill and shall be produced on demand before any officer, inspector, etc. of the Government/ BHEL.

In respect of all labours directly or indirectly employed in the work of the performance of the contractor's part of the contract, the contractor shall its own expenses arrange for the safety provisions as per BHEL safety clause framed from time to time and shall its own expense provide for all facilities in connection therewith. In case the contractor fails to make arrangement and provide necessary facilities aforesaid the Engineer-in-charge shall be at liberty to make arrangement and provide facilities as aforesaid and recover in full the costs incurred in that behalf from the contractor.

Should it appear to the Engineer-in-charge that the contractor is not properly observing and complying with the provisions of the BHEL Contractor's Labour Regulations and Model Rules and the Contract Labour (Regulation and Abolition) Central Rules 1971, for the protection of health and sanitary arrangements for the workmen employed by the contractor, (hereinafter referred as "the said Rules") the Engineer-in-charge shall have the power to give notice in writing to the contractor requiring that the said rules be complied with and the amenities prescribed therein be provided to the workmen within a reasonable time to be specified in the notice. If the contractor shall fail within the period specified in the notice to comply with and/observe the said Rules and to provide the amenities to the workmen as aforesaid, the Engineer-in-charge shall have the power to provide amenities herein before mentioned at the cost of the contractor.

The Engineer-In charge may require the contractor to dismiss or remove from the site of the work any person or persons in the contractor's employee upon the work who may be incompetent or misconduct himself and the contractor shall forthwith comply with such requirements.

It shall be the responsibility of the contractor to see that the building under construction is not occupied by anybody unauthorized during construction, and is handed over to the Engineer-in-charge with vacant possession of complete building. If such building though completed is occupied illegally, then the Engineer-in-charge shall have the option to refuse to accept the said building/ buildings in that position.

However, the Engineer-in-charge, through a notice, may require the contractor to remove the illegal occupation any time on or before construction and delivery. The contractor will be liable for all payments to be made under the law and for the observance of the regulations aforesaid without prejudice to his right to claim indemnity from his subcontractor.

## **2.20 ACCOMMODATION FOR LABOUR:**

The contractor shall during the progress of the work, provide, erect and maintain at his own expense and approved standards and scales, all necessary temporary living and sanitary accommodation required for his work people on the site, in connection with the execution of the work and also arrange for supply of wholesome drinking water for his work people.

The planning, sitting, layout and erection of these temporary buildings shall be approved by the Engineer-in-charge and the whole of such temporary accommodation shall at all times during the progress of the work be kept tidy and in clean sanitary conditions to the entire satisfaction of the Engineer-in-charge and at the contractor's expenses. The contractor shall confirm generally to the sanitary requirements of the local medical

**Bharat Heavy Electricals Limited**  
Heavy Plates & Vessels Plant, Visakhapatnam

GENERAL CONDITIONS OF CONTRACT (Works / Services)

PAGE 19 OF 30

and health authority and at all times with such precautions that may be necessary to prevent soil pollution of the site.

On completion of the work all such temporary buildings shall be cleaned away, all rubbish burnt, excrete or other disposal pits or trenches filled and effectively sealed off and the whole of the site left clean and tidy to the entire satisfaction of the Engineer-in-charge and at the contractor's expense.

**2.21 ANTI MALARIAL PRECAUTION:**

The contractor shall at his own expenses, conform to all anti-malarial instruction given to him by the Engineer-in-charge including filling up of borrow pits, if any.

**2.22 CONSERVANCY:**

The contractor shall at his own expenses, carry out all instructions issued to him by Engineer-in-charge to effect a proper disposal to night soil and other conservation work in respect of the contractors work people or his employees on the site.

The contractor will bear the cost of any charges levied by the local authority for the execution of such work on his behalf.

**2.23 NUISANCE:**

The contractor shall not at any time do, cause or permit any nuisance on the site or do anything which may cause unnecessary disturbance or inconvenience to the owners, tenants or occupier of other properties near the site and to the public generally and shall secure the efficient protection of streams and water ways against pollution.

**2.24 WATER & ELECTRICITY:**

Water and electricity shall be supplied to the contractor by the department subject to the following conditions:

- i) One/ two source of supply of water/ electricity points, to be decided by Engineer-in-charge, shall be provided by BHEL. However, contractor shall have to make their own arrangement for laying of pipelines/ connection from the main source of supply for working at site.
- ii) Department do not guarantee to maintain uninterrupted supply of water/ electricity and it will be incumbent on the contractor to make alternative arrangement for proper supply of the same at their own cost in the event of any break down in the government water/ electricity mains so that the progress of work is not held up for the want of the same. No claim of damage or refund will be entertained on account of such break down.
- iii) In case of non-availability of above facilities at work place, contractor has to make his own arrangements at his cost or as mentioned in the NIT.

**2.25 TEMPORARY WORKSHOPS STORES etc.:**

The contractor shall, during the progress of work, provide, erect and maintain at his own expense all necessary temporary work-shops, stores, offices etc. required for the proper and efficient execution of work. The planning, sitting and execution of these buildings/ works shall have the approval of the Engineer-in-charge and the contractor shall at all times keep them tidy in a clean and sanitary condition to the entire satisfaction of the Engineer In-charge.

**2.26 STORES AND MATERIALS ON SITE:**

All stores and materials for the work are to be deposited by the contractor only in places to be indicated by the Engineer In charge, where in accordance with the contract, stipulations certain stores and materials (for incorporation in the work) are to be issued to the contractor by BHEL as detailed.

BHEL free issue items will be so issued only to the extent required for the actual completion of the work as stipulated in the contract. The decision of Engineer-in-Charge / Head of the department regarding the quantities to be issued as above shall be final and binding on the contractor. For any excess quantities consumed on the work, the cost will be recovered from the contractor at punitive rates, which will be as mentioned in Schedule "B".

**Bharat Heavy Electricals Limited**  
Heavy Plates & Vessels Plant, Visakhapatnam

GENERAL CONDITIONS OF CONTRACT (Works / Services)

PAGE 20 OF 30

As regard issue of material and stores to be issued to the contractor by BHEL, the contractor shall give the Engineer-in-charge reasonable notice in writing of his requirement of such stores/ materials and on the approval of his demand being notified to him, he shall make immediate arrangement for drawing the same. Such stores and materials shall be transported by the contractor at his own expense direct from the place of issue to the site of work with the prior written approval, obtained from the Engineer-in-charge to take them to a store or work shop or elsewhere. BHEL officers connected with the contract shall have the power at any time to inspect and examine any stores or at any factory or workshop or other place where material intended to be used in or on the workshop, or other places such stores or materials are being fabricated or manufactured, or at any place where the same are lying and the contractor shall give necessary facilities for such inspection and examination.

The Engineer-in-charge shall be entitled to have tests made of any stores or materials supplied by the contractor who shall provide at his own expense all facilities which the Engineer-in-charge may require for this purpose. If at the discretion of Engineer-in-charge, independent expert is employed to make any such test, his charges shall be borne by the contractor only, if the test disclosed that the said stores or materials are not in accordance with the provisions of the contract.

Should the Engineer-in-charge consider at any time during the construction or reconstruction or prior to the expiry of the maintenance period that the stores or materials provided by the contractor are unsound or of a quality inferior to the constructed or otherwise and not in accordance with the contract (in respect whereof the decision of the Engineer-in-charge shall be final and conclusive). The contractor shall on demand in writing from the Engineer-in-charge specifying the stores or materials complained or notwithstanding that the same may have been inadvertently passed, certified and paid for, forthwith remove the stores or materials so specified and provide other proper and suitable stores or materials at his own expense to the entire satisfaction of Engineer-in-charge and in the event of his failing to do so within a period to be specified by Engineer-in-charge in his demand aforesaid, the Engineer-in-charge may replace with others, the stores or materials complained of, at the risk and expense in all respect of the contractor.

The liability of the contractor under this condition shall not extend beyond the maintenance period aforesaid except as regard stores or materials, which the Engineer-in-charge shall have previously given, notice to the contractor to replace that. (Maintenance period for any work under this organization will be TWELVE MONTHS from the date of actual completion of the particular work and handing over to BHEL in the case of building works and SIX MONTHS for all other works.).

All stores and materials brought to the site shall become and remains the property of BHEL and shall not be removed from the site without the prior written approval of the Engineer In charge. However, when the work is finally completed, the contractor shall at his own expense forthwith remove from the site surplus stores and materials originally supplied by him and upon such removal the same shall revert and become the property of the fixing in the work and which after making due allowance for the reasonable wear and tear/ or waste have not on completion of the works been so incorporated or fixed, shall be returned by the contractor at his own expense to the place of issue.

Credit for surplus stores and/ or material returned by the contractor to BHEL will be given to him at a price, based on the prevailing market rate but not exceeding that at which the said stores and materials were originally issued to him but due consideration shall be given to the allowance claimed by BHEL, in respect of any depreciation or damage suffered by the stores and / or materials while in the custody of the contractor regarding which the decision of Engineer-in-charge shall be final and conclusive.

If in the opinion of the Engineer-in-charge(which will be final and conclusive) any stores supplied by the BHEL have either during progress of work or after completion of work but under the custody of the contractor, become damaged to such an extent that they cannot be usefully utilized either in the same work or in other work, the Engineer-in-charge shall not accept the stores and in the event of his so rejecting, the contractor shall be charged for the said stores at a rate fixed by the accepting officer. The contractor shall not be entitled to any claim whatsoever on this account.

**Bharat Heavy Electricals Limited**

Heavy Plates &amp; Vessels Plant, Visakhapatnam

GENERAL CONDITIONS OF CONTRACT (Works / Services)

PAGE 21 OF 30

**2.27 TOOLS AND PLANTS ON SITE:**

All tools, plants and equipment brought to site shall become the property of the BHEL and shall not be removed from the site without the prior written approval of the Engineer In charge. When the work is finally completed or contract is terminated for reasons other than the default of the contractor, the contractor shall forthwith remove from the site all tools, plants and equipments (other than those as may have been provided by BHEL) and upon such removal the same shall become the property of the contractor.

**2.28 STATEMENT OF HIRE CHARGES:**

A monthly detailed statement of the hire charges incurred in respect of BHEL tools, plants, equipment etc. shall be given to the contractor by the Engineer-in-charge.

**2.29 PRECAUTIONS AGAINST RISK:**

The contractor shall be responsible for providing at his own expense, for all precautions to prevent loss or damage from any and all risk and to minimize the amount of any such loss or damage and for necessary steps to be taken for the said purpose until the works have been handed over complete in all respect to the Engineer In-charge.

The contractor shall provide all watchmen necessary for the protection of site, the work, the materials, tools, plants, equipment and anything else lying in the site during the progress of work. He shall solely be responsible for and shall take all responsible and proper steps for protecting, securing and watching all and/ or about the work and the site which may be dangerous to any person whatsoever.

**2.30 NOTICES AND FEES:**

The contractor shall give all notices required by any statutory provisions or by the regulations and/ or bye-laws or any local authority and/ or of any public service, company or authority affected by the work or with those systems if the same are or will be contracted. The contractor shall pay and indemnify BHEL against any fees and charges demandable by law under such Acts, Regulations and/ or bye-laws in respect of the work and shall make and supply all drawings and plans required in connection with any such notice.

**2.31 SETTING OUT OF THE WORK & PROTECTING/ MAINTAINING SIGNALS & MARKS:**

The Engineer-in-charge shall supply dimensions, drawings, levels and other information necessary to enable the contractor to set out the work. The contractor shall at his own expense set out accurately according to the drawings, figures and dimensions there, on all the work in the contract and any extras or additions thereto and shall be solely responsible for their being so set out and executed. All bench marks, pegs, signals on surface, alignment stones, mile stones and all similar marks whether putting by BHEL authorities for the purpose of checking the contractor's work in the tenure of the contractor, be put under the care of the contractor who shall, at his own expense take all proper and responsible precautions and care to preserve and maintain them in their true position. In the event of these marks being disturbed or obliterated by accident or due to any other cause whatsoever the same may, if deemed necessary, be replaced by the Engineer – In – Charge / Head of the department to the contractor's expense and the cost thereof deducted from any money thereon or/ after becoming due to the contractor.

Where requested by the contractor, the level mark, centre line and chain age pegs corresponding to those as shown on the drawings, will be pointed out to the contractor on the ground but all bench marks or chain age pegs additional to these shown on the drawing shall be provided by the contractor at his expense.

**2.32 SITE DRAINAGE:**

All water that may accumulate on the site during the progress of the work or in trenches and excavations shall be removed by the contractor to the entire satisfaction of the Engineer-in-charge at his own expense.

**2.33 EXCAVATION RELICS etc.:**

Material of any kinds obtained from excavation on the site shall remain the property of BHEL and shall be disposed off as the Engineer-in-charge directs. All gold, silver, oil and other materials of any description and all

**Bharat Heavy Electricals Limited**  
Heavy Plates & Vessels Plant, Visakhapatnam

GENERAL CONDITIONS OF CONTRACT (Works / Services)

PAGE 22 OF 30

precious stones, coins, treasures, relics, antiquities and other similar items which may be found on at/upon the site shall be the property of the BHEL.

**2.34 FOUNDATIONS:**

The contractor shall not lay any foundation until the excavations for the same have been examined and approved in writing by the Engineer-in-charge.

**2.35 COVERING OF WORK:**

The contractor shall give reasonable notices in writing to the Engineer-in-charge whenever any work is to be permanently covered or cancelled, whether by earth or other means so that it can finally be inspected or measured if necessary. In default of doing so the contractor shall, if required by the Engineer-in-charge uncover such work at his own expense.

**2.36 APPROVAL OF WORKS BY STAGES:**

All work embracing more than one process shall be subject to examination and approval at each stage and the contractor shall give due notice in writing to the Engineer-in-charge when each stage is ready. In default of such notice being received, the Engineer-in-charge shall be entitled to approve the quality and extent thereof at any time he may choose and in the event of any dispute, the decision of the Engineer-in-charge thereon shall be final and conclusive.

**2.37 EXECUTION OF WORK:**

The work shall be executed in a workman like manner and to the satisfaction in all respect of the Engineer-in-charge. The Engineer-in-charge will communicate or confirm his instruction to the contractor in respect of the execution of the work in a "WORK SITE ORDER BOOK " maintained at his office and the contractor shall visit this office, daily and shall conform receipt of such instructions by signing the relevant entries in this book. Such entries will rank as order notices in writing within the intent and meaning of these conditions.

**2.38 RESPONSIBILITY FOR BUILDINGS:**

In the event of any building or part of any building being handed over to the contractor for execution of work thereto under provisions of the contract, he shall give a written receipt for all fixtures, glasses etc. and shall be required to make good at his own expense all damage resulting from whatsoever cause while in his charge and on completion of the work to deliver up the said building or part thereof in a clean stage complete in every particular to the entire satisfaction of the Engineer In charge.

**2.39 INSPECTION OF WORKS:**

BHEL Officers / BHEL representatives concerned with the contract shall have power at any time in respect and examine any part of the work and the contractor shall provide such facilities as may be required for such inspection and examination. Should the Engineer-in-charge consider at any time during the construction or reconstruction or prior to the expiry of maintenance period, that any work has been executed with unsound, imperfect or unskilled workmanship or of a quality inferior to that contracted for or not otherwise in accordance with the contract, in respect whereof the decision of the Engineer-in-charge shall be final and conclusive. The contractor shall on demand in writing from the Engineer-in-charge specifying the fault notwithstanding that the same may have been inadvertently passed, certified and paid for, forthwith rectify or remove and reconstruct, the work so specified, in whole or in part as the case may be, require at his own risk and expense to the entire satisfaction of Engineer-in-charge, who may accept the work at reduced rate if deemed fit. However, the liability of the contractor under this condition shall not extend beyond the maintenance period except as regard workmanship, which the Engineer-in-charge should have previously given notice to the contractor to rectify.

**2.40 DAMAGE AND LOSS TO PRIVATE PROPERTY AND INJURY TO WORKS:**

The contractor shall at his own expense reinstate and make good to the satisfaction of the Engineer-in-charge and pay compensation for any injury, loss or damage caused to any property or right what so ever including property or/ and rights of BHEL (or agent /servants/any outsider or employees of BHEL) and the injury, loss or damage arising out of or in any way in connection with the execution or purported execution of the contract and further the contractor shall indemnify BHEL, against all claims enforceable against BHEL) or which would be so

**Bharat Heavy Electricals Limited**  
Heavy Plates & Vessels Plant, Visakhapatnam

GENERAL CONDITIONS OF CONTRACT (Works / Services)

PAGE 23 OF 30

enforceable against BHEL were BHEL a private person in respect of any such injury (including injury resulting in death, loss or damage to any person whatsoever or property, including all claims which may arise under Workman's Compensation Act or otherwise.

**2.41 COMPLETION:**

The works shall be completed to the entire satisfaction of the Engineer In-charge and in accordance with contractor's forecast of time and progress where operative and that, all unused stores and materials, tools, plant, equipment, temporary buildings and things shall be removed and the site and work cleared of rubbish and all waste material and delivered up clean and tidy to the satisfactions of the Engineer-in-charge at the contractor's expense on or before the scheduled date of completion. BHEL shall have power to take over from the contractor from time to time such section of work as have been completed to the satisfaction of the Engineer In-charge. The Engineer-in-charge shall certify to the state of the work at the end of the maintenance period where applicable.

**2.42 COMPENSATION AS LIQUIDATED DAMAGES FOR DELAY:**

If the contractor fails to complete and clear the site on or before the scheduled date of completion or does not achieve the progress as set out under the caption "TIME " in clause 2.6 of these General Conditions, he shall without prejudice to any other right or remedy on BHEL on account of such breach, be liable to pay as compensation as liquidated damage an amount equal to 0.50 percentage of the total contract sum for every week (7 days) of extension sought beyond the scheduled date of completion of the contract provided always that the total amount of compensation as liquidated damages to be paid under this condition shall not exceed 10% of the contract sum. Such amount may be adjusted or set off against any sum payable to the contractor under this or any other contract. If delay is for 8 days, it will be counted as delay for 2 weeks for liquidated damages. In case any penalty is to be levied at any stage during the progress of work, reference shall be made to the clause as mentioned in special condition of tender.

**2.43 CANCELLATION OF CONTRACT FOR CORRUPT ACTS:**

The Accepting Officer, whose decision shall be final and conclusive, shall without prejudice to any other right or remedy which shall have accrued or shall accrue thereafter, BHEL cancel the contract if any of the following cases and the contractor shall be liable to pay to BHEL for any loss or damage relating from any such cancellation to the same extent as provided in the case of cancellation of defaults.

If the contractor---

- a) Offer to give or agree to give to any person in BHEL service, any gift or consideration of any kind as an inducement or reward for doing or forbearing to do for having done or for borne to do any act in relation to obtaining or execution of this or any other contract for BHEL service

**OR**

- b) Enter into a contract with BHEL in connection with which commission has been paid or agreed to be paid by him or with his knowledge, unless the particulars of any such commission and the terms of payment thereof have previously been disclosed in writing to the Accepting Officer.

**OR**

- c) Obtain a contract with BHEL as a result of ring tendering or by non-bearing methods or competitive tendering without first disclosing the fact in writing to the Accepting Officer.

**OR**

- d) Steel or misuse of any property of BHEL either by himself or through his workmen within his knowledge or convince.

**2.44 CANCELLATION OF CONTRACT DUE TO INSOLVENCY, ASSIGNMENT OR TRANSFER OR SUBLETTING OF CONTRACT:**

The Accepting Officer, without prejudice to any other right or remedy, which shall have accrued or shall accrue thereafter to BHEL, shall cancel the contract in any of the following cases:

**Bharat Heavy Electricals Limited**

Heavy Plates &amp; Vessels Plant, Visakhapatnam

GENERAL CONDITIONS OF CONTRACT (Works / Services)

PAGE 24 OF 30

If the contractor ----

- a) Being an individual or if a firm, or any partner thereof shall at any time to be adjudged bankrupt or having a receiving order or order for administration of his estate made against him or shall take any proceedings for liquidation or composition under any Bankruptcy Act for the time being enforce or make any connivance or assignment or makes unauthorized or illegal arrangement for the benefit of his creditors or propose to do so, or if any application be made under any bankruptcy and for the time being in force for the sequestration of his estate or if a trust deed be granted by him on behalf of his creditors,

**OR**

- b) Being a company, shall pass a resolution or the court shall make an order for the liquidation of its affairs, or a receiver or Manager on behalf of the debenture holders shall be appointed or circumstances shall arise which entitle the court of debenture holders to appoint a receiver or Manager.

**OR**

- c) Assigns, sublets or attempts to assign, transfer or sublet any portion of the work without the prior written approval of the Accepting Officer,

Whenever the Accepting Officer exercises his authority to cancel the contract under this condition, he may complete the work by any means at the contractor's risk and expense, provided that, in the event of the cost of completion (as certified by Engineer In charge, which is final and conclusive) being less than the contract cost the advantage shall accrue to the BHEL, and that if the cost of completion exceeds the money due to the contractor under the contract, the contractor shall either pay the excess amount ordered by the Engineer-in-charge or the same shall be recovered from the contractor by other means

In case BHEL completes the work under the provisions of this condition, the cost of such completion to be taken into account in determining the excess cost to be charged to the contractor under this condition shall consist of the cost of materials purchased and/ or labour provided by BHEL with an addition of such percentage to cover superintendence and establishment charges as may be decided by the DGM / GM, whose decision shall be final and conclusive.

#### **2.45 CANCELLATION OF CONTRACT IN PART OR IN FULL FOR CONTRACTOR'S DEFAULT:**

If the contractor—

- a) Makes default in commencing the work within a reasonable time from the date of handing over of the site and continues in that state after a reasonable notice from the Engineer In charge.

**OR**

- b) In the opinion of the Engineer-in-charge at any time, whether before or after the date or extended date for completion, makes default in proceeding with the work with due diligence and continues in that state after reasonable notice from Engineer-in-charge.

**OR**

- c) Fails to complete the work, without prejudice to any other right or remedy which shall have accrued, or shall accrue thereafter to BHEL contract.

**OR**

- d) Fails to comply with any of the terms and conditions of the contract after reasonable notice in writing with order properly issued.

**OR**

- e) Fails to complete the work, work order, and items of work with individual dates for completion and clear the site on or before the date of completion, or if fails to achieve the conditions of contract, the Accepting Officer, may without prejudice to any other right or remedy which shall have accrued or shall accrue thereafter or do only such work order or items of work in default from the contract at the expense and cost of the contractor.

**Bharat Heavy Electricals Limited**

Heavy Plates &amp; Vessels Plant, Visakhapatnam

GENERAL CONDITIONS OF CONTRACT (Works / Services)

PAGE 25 OF 30

Whenever the Accepting Officer exercises his authority to cancel the contract as a whole or in part under this condition, he may complete the work as a whole or part to under this contract, the contractor shall either pay the excess amount ordered by Engineer-in-charge or the same shall be recovered from the contractor by other means.

In case of BHEL completes the work or any part thereof under the provisions of this condition, the cost of such completion to be taken into account in determining the excess cost to be charged to the contractor under this condition, shall consist of the materials purchased and/ or labour provided by BHEL with an addition of such percentage to cover superintendence and establishment charges as may be decided by the DGM whose decision shall be final and conclusive.

In the event of termination of contract for any reason whatsoever, the contractor shall withdraw all his employees from the establishment of BHEL. In case contractor decides to terminate services of his employees he should settle all terminal dues including retrenchment compensation.

**2.46 TERMINATION OF CONTRACT DUE TO DEATH:**

Without prejudice to any of the rights or remedies under this contract, if the contractor dies, the Accepting Officer shall have the option of terminating the contract without compensation to the contractor authorized survivors.

**2.47 SPECIAL POWERS OF TERMINATION:**

If at any time after the acceptance of the tender, BHEL shall for any reason whatsoever not require the whole or any part of the work, to be carried out, the Engineer-in-charge shall give notice in writing of the fact to the contractor, who shall have no claim to any payment of compensation or otherwise, howsoever on account of any profit or advantage which he might have derived from the execution of the work in full but which he did not derive in consequence of the foreclosing of the work.

The contractor shall be paid at contract rates for the full amount of the work executed including such additional work i.e., cleaning of site etc. as may be rendered necessary by the said foreclosing. He shall also be allowed a reasonable payment (as decided by the Accepting Officer) for any expenses sustained on account of labour and material collected but which could not be utilized on the work as verified by the Engineer-in-charge but the contractor shall not have any claim for compensation on account of any alterations having been made in the original specifications, drawings, designs and instructions involving and curtailment of the work as originally contemplated.

**2.48 FAIR WAGE:**

Refer clause 2.19 of General terms and conditions of Contract.

**Bharat Heavy Electricals Limited**

Heavy Plates &amp; Vessels Plant, Visakhapatnam

GENERAL CONDITIONS OF CONTRACT (Works / Services)

PAGE 26 OF 30

**CHAPTER-III**  
**VALUATION AND PAYMENT**

**3.1 RECORDS AND MEASUREMENTS:**

All items having a financial value shall be entered in the BHEL Measurement book so that a complete record is obtained on all work performed under the contract.

Measurement shall be carried out as per unit mentioned in the bill of quantity (price-bid).

The measurements shall be taken jointly by any person or persons duly authorized on the part of the BHEL and the contractor.

The Engineer-in-charge shall give reasonable notice in writing to the contractor of appointments for measurements.

The contractor shall without extra charge, provide assistance with appliance and other things necessary for measurements.

The contractor shall bear all the cost of measurement of his work.

Measurements shall be entered in the BHEL measurement book and signed and dated by both parties each day on the site on completion of measurement. If the contractor objects to any of the measurement recorded on behalf of BHEL in the Measurement Book or against the item or items objected to, and such note shall be signed and dated by both parties engaged in taking the measurements.

If as a result of such objection it becomes necessary to remeasure the work wholly or in part, the expense of such measurement shall be borne by the party requiring the measurement to be retaken provided that net error found by this remeasurement amount to less than 5 % (five percent) of the value as recorded by the first measurement.

If the contractor's representative fails to attend when required, the Engineer-in-Charge shall have power to proceed by himself to take measurements, and in that case these measurements shall be accepted by the contractor as final.

The contractor shall once in every month, submit to the Engineer with a copy to the concerned Engineer-in-charge details of his claims for the work done by him up to and including the previous month which are not covered by his contract agreement in any of the following respects: -

- a) Deviation from the item and specification provided in the contract documents.
- b) Extra items / new items of the work.
- c) Quantities in excess of those provided in the contract agreement.
- d) Items in respect of which rates have not been settled, in addition furnish a clear certificate to the effect that the claims submitted by him as aforesaid cover all his claims and that no further claims shall be raised by him in respect of the work done up to and including the period under report.

**3.2 FINAL BILLS:**

As soon as possible after the completion of the work to the satisfaction of the Engineer-in-charge, the contractor shall forward a certified final account on BHEL forms in duplicate. It shall be accompanied with all abstracts; vouchers etc. in support thereof and shall be prepared, in the manner prescribed by the Engineer In charge. No claims will be entertained after the receipt of the final bills.

The contractor shall be entitled to be paid the final sum less the value of payments already made on account subject to certification to the final bill by the Engineer-in-Charge. No charge shall be allowed to the contractor on account of the preparation of the final bills.

**Bharat Heavy Electricals Limited**  
Heavy Plates & Vessels Plant, Visakhapatnam

GENERAL CONDITIONS OF CONTRACT (Works / Services)

PAGE 27 OF 30

**3.3 PAYMENTS OF BILLS:**

The payment of final bill will be made only after successful proving. All payments to be made to the contractor under this contract shall be through online payment i.e., RTGS/ NEFT within a reasonable time after the certification by the Engineer-in-charge.

**3.4 RECOVERY FROM THE CONTRACTOR:**

Whenever under the contract any sum of money shall be recoverable from or payable to the contractor, the same may be deducted from any sum then due or which at any time thereafter may become due to the contractor under the contract or under any other contract with BHEL or from his security deposit, or he shall pay the claim on demand.

**3.5 POST TECHNICAL AUDIT OF WORK & BILLS:**

BHEL reserves the right to carry out a post payment audit and technical examination of the work and bill including all supporting vouchers, abstracts etc. and to enforce recovery of any sums becoming due as a result thereof in the manner provided into the proceedings sub-paragraph provided, however, that no such recovery shall be enforced after three years of passing the final bills.

**3.6 REFUND OF SECURITY DEPOSIT:**

After expiration of the maintenance period, provided always that the contractor shall first have been paid final bill and have rendered a "No Demand" certificate, the security deposit mentioned *shall be released after satisfactory completion of the maintenance period* of the work duly verified by Site In charge. *The maintenance period of work is 3 months from the date of actual completion of work.*

**3.7 ARBITRATION:**

All disputes between the parties to the contract arising out of or relating to the contractor other than those for which the decision of the Engineer-in-charge/ Accepting Officer or any other person is by the contract expressed to be final and conclusive, shall after written notice by either party to the contract, the other party be referred to the sole arbitration of Unit Head or any other officer of BHEL in his sole discretion unless the parties otherwise agree, such reference shall not take place until after the completion, alleged completion or abandonment of the work or the determination of the contract. The venue of arbitration proceedings will be at Visakhapatnam. The arbitrator shall have the power to extend, from time to time, the time for making his award with the consent of the parties. The award of the Arbitrator shall be final, conclusive and binding on both the parties to the contract. Any matter arising out of or in connection with the agreement shall be under jurisdiction of Visakhapatnam court. The Head of HPVP Unit of BHEL, Visakhapatnam shall appoint the Arbitrator. No person other than a person so appointed shall act as Arbitrator.

**3.8 IMPLEMENTATION OF PROVISION OF THE APPRENTICE ACT:**

Contractor shall comply with the provisions of Apprentice Act-1961, and the Rules and Orders issued there under from time to time. If he fails to do so his failure will be a breach of the contract and the Accepting Authority may, in his discretion cancel the contract. The contractor shall also be liable for any pecuniary liability arising on account of any violation by him of the provision of the Act.

**3.9 SAFETY AND SECURITY:**

1. BHEL reserves the right to take penal action as deemed fit if any information provided by the vender / contractor is found to be incorrect.

**2. Other safety related conditions:**

a) The contractor shall ensure proper safety of all the workmen, materials, plant and belonging to him or to BHEL or to others, working at or near the site. The contractor shall also be responsible for provision of all safety notices and safety equipment required both by the relevant legislation and the Engineer-in-charge as he may deem necessary.

**Bharat Heavy Electricals Limited**  
Heavy Plates & Vessels Plant, Visakhapatnam

GENERAL CONDITIONS OF CONTRACT (Works / Services)

PAGE 28 OF 30

- b) The contractor shall adopt adequate safety measures and use of protective clothing by all the workmen at site/work place whether engaged or not in actual of work or supervision thereof. The contractor shall ensure that the workmen on site use safety belt, gloves, helmets, masks etc. as are necessary for their safety.
- c) The contractor shall be responsible for safety arrangements of all equipment used in connection with the execution of the work and shall ensure employment of only trained person to operate the equipment. Only tested equipment, tools, wires, ropes etc. shall be used and shall periodically be tested to the satisfaction of the BHEL. All test certificates shall be made available to the BHEL at site as and when required.
- d) The contractor shall ensure provision and maintenance of lights, guards, fencing with gates and watching when and where necessary or required by the BHEL or by any one duly constituted authority for the protection of the work and / or for the safety and convenience of the public or others.
- e) The contractor shall take adequate safety precautions for prevention of accidents at site. The contractor shall also ensure that their employees / workmen comply with the statutory safety rules and regulations as and also those laid down by BHEL from time to time.
- f) The contractor shall provide at his cost necessary watch and ward force as may be approved by the BHEL to ensure security and safety of all buildings, structures, equipments and materials under their custody at the site of work.
- g) The contractor shall abide by all security regulations at site by the BHEL from time to time. The contractor shall provide identify badges to their personnel and workmen, which must be properly displayed by them at site.
- h) In order to facilitate issue of exit gate permits by the BHEL for materials and equipments either during execution or the maintenance period, the CONTRACTOR shall submit to the BHEL list of construction / erection equipment etc. and / or other materials that shall be taken by them inside the site from time to time. Such movement of materials, equipment, tools, tackles etc. shall be subject to certification by the Engineer In charge.
- i) The contractor and his personnel / workmen shall be subject to security check by BHEL's own security force or Central Industrial Security Force if engaged by the BHEL for the overall protection of the project.
- j) The contractor shall not allow any visitors on the works except with the written permission of the BHEL.
- k) From the commencement to the completion of work, the contractor shall take full responsibility for the care of the work, constructional plant and equipment and all temporary works and in case any damage or loss shall happen to the work, constructional plant and equipment or to plant temporary work from any cause whatsoever, the contractor shall at his own cost replace or repair and make good the same.
- l) The contractor will notify well in advance to the Engineer-in-charge of his intention to bring to site any container filled with liquid or gaseous fuel explosive or petroleum substance or such chemicals, which may involve hazards. The Engineer-in-charge shall have the right to prescribe the conditions under which such containers are to be stored, handled and used during the performance of the works and the contractor shall strictly adhere to and comply with such instructions. The Engineer-in-charge shall have to right at his sole discretion to inspect any such container or such construction plant / equipment, for which material in the container is required to be used and if in his opinion, its use is not safe, he may forbid its use. No claim due to such prohibition shall be entertained by BHEL nor shall BHEL entertain any claim of the contractor towards additional safety provisions/ conditions to be provided for/ constructed as per Engineer-in-charge instructions compliance to statutory in respect of such conditions will be the sole responsibility of the contractor.
- m) Further any such decision of the Engineer-in-charge shall not in any way absolve the contractor of his responsibilities for safety provisions and in case, use of such a container or entry thereof into the site area is forbidden by Engineer-in-charge without any cost implications to BHEL or extension of work schedule.
- n) Where it is necessary to provide and/ or store petroleum products or petroleum mixtures and explosive, the contractor shall be responsible for carrying out such provision and / or storage in accordance with the rules

**Bharat Heavy Electricals Limited**

Heavy Plates &amp; Vessels Plant, Visakhapatnam

GENERAL CONDITIONS OF CONTRACT (Works / Services)

PAGE 29 OF 30

and regulations laid down in Petroleum Act 1934, Explosives Act 1948 and Petroleum and Calcium Carbide Manual published by the Chief Inspector of Explosives of India. All such storage shall have prior approval of the Engineer-in-charge. In case, any approval is necessary from the Chief Inspector (Explosives) or other statutory authorities, the contractor shall be responsible for obtaining the same.

- o) All equipment used in construction & erection by the contractor shall meet Indian/ International Standards and where such standards do not exist, contractor shall ensure these to be absolutely safe. All equipment shall be strictly operated and maintained by the contractor in accordance with manufacturer's operation manual and safety instructions and as per guide lines/ rules of BHEL in this regard.
- p) Periodical examination and all tests for all lifting/ hoisting equipment and tackles shall be carried out in accordance with the relevant provisions of Factories Act 1948, Indian Electricity Rules 1910 and associated Law/ Rules in force from time to time. A register of such examinations and tests shall be promptly produced as and when desired by Engineer-in-charge or Safety Officer.
- q) Contractor shall provide suitable safety equipment of prescribed standard to all employees and workmen according to the need at his own cost as may be directed by Engineer-in-charge who will also have the right to examine these safety equipments to determine their suitability, reliability, acceptability and adoptability.
- r) The contractor shall provide safe working conditions to all workmen and employees at the site including safe means of access, railings, stairs, ladders, scaffolding, safety belts etc. the scaffoldings shall be erected under the control and supervision of an experienced and competent person.
- s) The contractor shall not interfere with or disturb electric fuses, wiring and other electrical equipment belonging to BHEL or other contractors under any circumstances whatsoever, unless specially permitted in writing by BHEL to handle such fuses, wiring or electrical equipment.

Before the contractor connects any electrical appliances to any plug or socket belonging to the other contractor or BHEL, he shall:

- i) Satisfy the Engineer-in-charge that the appliance is in good working condition.
- ii) Inform the Engineer-in-charge of the maximum current rating voltage and phases of the appliances.
- iii) Obtain permission of the Engineer-in-charge detailing the sockets to which the appliances may be connected.

**The Engineer-in-charge will not grant permission to connect until he is satisfied that:**

- i) The appliance is in good condition and is fitted with a suitable plug.
- ii) The appliance is fitted with suitable cable having two earth conductors, one of which shall be an earthed metal sheet surrounding the cores.
- iii) No electrical cable in use by the contractor will be disturbed without prior permission. No weight of any description will be imposed on any cable and no ladder or similar equipment will rest against or attached to it.
- iv) No repair work shall be carried out on any live equipment, the equipment must be declared safe by the Engineer-in-charge and a permit to work shall be issued by Engineer-in-charge before any repair work is carried out by the contractor. While working on electric lines/ equipment whether alive or dead suitable type and sufficient quantity of tools will have to be provided by contractor to electricians/ workmen/ officers.
- t) The contractor shall employ necessary number of qualified full time electricians/ electrical supervisors to maintain his temporary electrical installations.
- u) In case any accident occurs during the construction/ erection or other associated activities undertaken by the contractor thereby causing any minor or major or fatal injury to his employees due to reason whatsoever, it shall be the responsibility of the contractor to promptly inform the same to BHEL Engineer-in-charge in prescribed form. The contractor will be responsible for all pecuniary liability if any under such circumstances.

**Bharat Heavy Electricals Limited**

Heavy Plates &amp; Vessels Plant, Visakhapatnam

GENERAL CONDITIONS OF CONTRACT (Works / Services)

PAGE 30 OF 30

- v) The Engineer-In charge and Safety Officer shall have the right at his sole discretion to stop the work, if in his opinion, the work is being carried out in such a way that it may cause accidents and endanger the safety of the person and/ or property and/ or equipments. In such cases, the contractor shall also be informed in writing about the nature of hazards and possible injury/ accident and he shall remove the shortcomings promptly. The contractor after stopping the specific work can, if felt necessary, appeal against the order of stoppage of work to the respective General Manager within 3 days of such stoppage of work and decision of GM in this respect shall be conclusive and binding on the contractor.
- w) Notwithstanding anything contrary to this, in the event of his workmen, the contractor shall be required to fill Injury Report and submit to the Shop Manager/ Engineer-in-charge of BHEL immediately and ensure due compliance of Workmen Compensation Act 1923 and Rules made there under.
- x) The contractor shall not be entitled to any damages/ compensation for stoppage of work due to safety reasons as provided above and the period of such stoppage of work will not necessarily be taken as an extension of time for completion of work and will not be the ground for waiver of levy of liquidated damages.
- y) The contractor shall follow and comply with all BHEL safety rules, relevant provision of applicable law pertaining to the safety of workmen, plant and equipment as may be prescribed from time to time without any demur protest or contest or reservation. In case of any unconformity between statutory requirement and BHEL Safety Rules referred above, the later shall be binding on the contractor unless the statutory provisions are more stringent.
- z) If the contractor fails in providing safe working environment as per the statutory requirements and / or BHEL Safety Rules or continue to work even after being instructed to stop the work by Engineer-in-charge or Safety Officer as provided above, the contractor shall promptly pay to BHEL, on demand, compensation at the rate of Rs. 500/- per day or part thereof till instructions are complied with and so certified by Engineer-in-charge/ Safety Officer. However, in case of accident taking place causing death/ injury to any individual the statutory provisions shall apply in addition to compensation mentioned in this para; and the contractor will be solely liable on account of this.

\* \* \*

**SPECIAL CONDITIONS OF CONTRACT (SCC)**

## Contents

<b>SI No</b>	<b>DESCRIPTION</b>	<b>Chapter</b>	<b>No. OF PAGES</b>
1	General Intent of the Specifications	Chapter-I	3
2	General Services to be rendered by the Bidder	Chapter-II	4
3	General Technical Requirements (Codes and Standards)	Chapter-III	5
4	Obligations of Contractor (In respect of Tools, Tackles, Consumables, etc. employment of supervisory staff and workmen)	Chapter-IV	6-8
5	Responsibilities of Contractor (In respect of employment of Labour, Supervisory staff, etc.)	Chapter-V	9
6	Material Handling, Storage, Preservation, etc.	Chapter-VI	10-11
7	Drawings and Documents	Chapter-VII	12
8	Inspection and Quality	Chapter-VIII	13-15
9	HSE & OHSAS Obligations	Chapter-IX	16-25
10	RA Bill Payment	Chapter-X	26
11	Performance Monitoring	Chapter-XI	27
12	Suspension of Business Dealings	Chapter-XII	28

SPECIAL CONDITIONS OF CONTRACT (SCC)

## Chapter - I: General Intent of Specifications

<b>1.0</b>	<b>INTENT OF THE SPECIFICATION</b>
1.1	The intent of this erection specification is to provide services for execution of the project according to most modern and proven techniques and codes. The omission of specific reference to any method, equipment or material necessary for the proper and efficient services towards installation of the plant shall not relieve the contractor of the responsibility of providing such services / facilities to complete the work or portion of work awarded to him. The quoted / accepted rates / price shall deem to be inclusive of all such contingencies.
1.2	The work shall conform to dimensions and tolerances given in various drawings and documents that will be provided during erection. If any portion of works is found to be defective in workmanship and not conforming to drawings / documents or other stipulations, the contractor shall dismantle and re-do the work duly replacing the defective materials at their own cost, failing which recoveries, as determined by BHEL, shall be effected from contractor's bills.
1.3	It is not the intent of this specification to specify herein all the details of erection and commissioning. However, the system shall conform in all respects to high standards of quality and workmanship for performing the required duties in a manner acceptable to purchaser who will interpret the meaning of drawings and specifications and shall be entitled to reject any work or material, which in his judgments is not in full accordance herewith.
1.4	The omission of specific reference to any fabrication / erection or other method, equipment or material necessary for proper and efficient working of the plant shall not relieve the tenderer of the responsibility of providing such facilities to complete the work at quoted rates. Any mismatch/ defect found due to mistake in fabrication / erection shall have to be rectified by the vendor free of cost. Inspection by BHEL/Customer does not relieve vendor of his responsibility of executing quality erection.
1.5	The work covered under this specification is of highly sophisticated nature, requiring the best quality workmanship, supervision, engineering and construction management. The contractor should ensure proper planning and successful and timely completion of the work to meet the overall project schedule. The contractor must deploy adequate quantity of tools & plants, modern / latest construction aids etc. He must also deploy adequate trained, qualified and experienced supervisory staff and skilled personnel.
1.6	Contractor shall erect and commission all the equipments and auxiliaries as per the sequence & methodology prescribed by BHEL depending upon the technical requirements. Availability of materials and fronts will decide this. BHEL Engineer's decision regarding correctness of the work and method of working shall be final and binding on the contractor. No claims for extra payment from the contractor will be entertained on the ground of deviation from the methods / sequence adopted in erection of similar sets elsewhere.
1.7	Following shall be the minimum responsibility of contractor and have to be provided within finally accepted rates / prices:
1.7.1	Provision as required of all types of labour, supervisors, engineers, watch and ward, tools & tackles, calibrated MMEs (Monitoring and Measuring Equipment) as specified and otherwise required for the work, consumables for erection, testing and commissioning including material handling.
1.7.2	Achieving Proper out-turns / Turn-over as per BHEL plan and commitment.
1.7.3	Completion of work as per BHEL Schedule.
1.7.4	Good quality and accurate workmanship for proper performance of the equipment
1.7.5	Repair and rectification
1.7.6	Preservation / Re-conservation of all components during storage / erection / commissioning till handing over.

SPECIAL CONDITIONS OF CONTRACT (SCC)

## Chapter - II: General Services to be rendered by the Bidder

<b>2.0</b>	<b>GENERAL SERVICES TO BE RENDERED BY THE BIDDER</b>
2.1	Services for construction, fabrication, equipment erection, testing as well as trial run & commissioning of various equipment and accessories under the contract shall include but not be limited to the following:
2.2	Issuing materials from store/open yard from time to time for erection as per the construction programme. The Contractor shall be the custodian of all the materials issued till the plant/equipment is officially taken over by the owner / BHEL after complete erection and successful trial run & commissioning.
2.3	Transport of material to their respective places of erection and erection of the complete plant & equipment as supplied under this specification.
2.4	Trial run and commissioning of individual equipment / sub-systems to the satisfaction of Owner/BHEL.
2.5	Deployment of all skilled and unskilled manpower required for erection, supervision of erection, watch & ward, commissioning and other services to be rendered under this specification.
2.6	Deployment of all erection tools & tackle, construction machinery, transportation vehicles and all other implements in adequate number and size, appropriate for the erection work to be handled under scope of this specification except otherwise specified.
2.7	Supply of all consumables, e.g. welding electrodes, gases, grinding/cutting wheels, cleaning agents, diesel oil, lubricant etc. as well as materials required for temporary supports, scaffolding etc. as necessary for such erection work, unless specified otherwise.
2.8	Providing support services for the contractor's erection staff e.g. construction of site offices, temporary stores, residential accommodation and transport to work site for erection personnel, watch and ward for security and safety of the materials under the Contractor's custody etc. as required.
2.9	Maintaining proper documentation of all the site activities undertaken by the Contractor as per the proforma mutually agreed with BHEL, Submission of monthly progress reports and any such document as and when desired by BHEL/owner, taking approval of all statutory authorities i.e. Boiler Inspector, Factory Inspector, Inspector of Explosives etc., as applicable for respective portions of work fall under the jurisdiction of such statutes of laws.
2.10	Any other service, although not specifically called for but required for a contract of the size and nature indicated in the specification.

SPECIAL CONDITIONS OF CONTRACT (SCC)

## Chapter - III: General Technical Requirements (Codes and Standards)

<b>3.0</b>	<b>GENERAL TECHNICAL REQUIREMENTS (CODES AND STANDARDS)</b>
3.1	Except where otherwise specified, the plant/equipment shall comply with the appropriate Indian Standard or an agreed internationally accepted Standard Specification as mentioned elsewhere in contract specifications, each incorporating the latest revisions at the time of tendering. Where no internationally accepted standard is applicable, the Bidder shall give all particulars and details as necessary; to enable BHEL to identify all of the plant/equipment in the same detail as would be possible had there been a Standard Specification.
3.2	Where the Bidder proposes alternative codes or standards he shall include in his tender one copy (in English) of each Standard Specification to which materials offered shall comply. In such case, the adopted alternative standard shall be equivalent or superior to the standards mentioned in the specification.
3.3	In the event of any conflict between the codes and standards referred above, and the requirements of this specification, the requirements which are more stringent shall govern.
3.4	Tools used during erection and commissioning shall not be accepted except with the specific approval of the Engineer.

SPECIAL CONDITIONS OF CONTRACT (SCC)

## Chapter - IV: Obligations of Contractor

<b>4.0</b>	<b>OBLIGATIONS OF CONTRACTOR</b>
<b>4.1</b>	<b>CONSUMABLES &amp; OTHER ITEMS</b>
4.1.1	The contractor shall provide within finally accepted price / rates, all consumables (except those indicated in BHEL scope) like welding electrodes (including alloy steel and stainless steel), filler wires, TIG filler wires, gases (inert, welding, cutting), soldering material, dye penetrants, radiography films, etc. Other erection consumables such as tapes, jointing compound, grease, mobile oil, M-seal, Araldite, petrol, CTC / other cleaning agents, grinding and cutting wheels are to be provided by the contractor. Steel, packers, shims, wooden planks, scaffolding materials hardware items etc. required for temporary works such as supports, scaffoldings are to be arranged by the contractor. Sealing compounds, gaskets, gland packing, wooden/concrete sleepers, for temporary work, required for completion of work except those which are specifically supplied by manufacturing unit are also to be arranged by the contractor.
4.1.2	All the shims, gaskets and packing, which are required for erection and alignment of equipments, shall be supplied by contractor free of cost.
4.1.3	It shall be the responsibility of the contractor to plan the activities and store sufficient quantity of consumables. Non-availability of any consumable materials or equivalent suggested by BHEL cannot be considered as reason for not attaining the required progress or for additional claim.
4.1.4	<b>Void.</b>
4.1.5	It shall be the responsibility of the contractor to obtain prior approval of BHEL, regarding suppliers, type of electrodes etc. before procurement of welding electrodes. On receipt of electrodes at site these shall be subjected to inspection and approval by BHEL. The contractor shall inform BHEL details regarding type of electrodes, batch number, date of expiry etc. and produce test certificate for each lot / batch with correlation of batch / lot number with respective test certificate. No electrode without a valid test certificate will be used.
4.1.6	BHEL reserves the right to reject the use of any consumable including electrodes, gases, lubricants / special consumables if it is not found to be of the required standard / make / purity or when shelf life has expired. Contractor shall ensure display of shelf life on consumable wherever required and records maintained.
4.1.7	Storage of all consumables including welding electrodes shall be done as per requirement / instruction of the Engineer by the contractor at his cost.
4.1.8	In case of improper arrangement for procurement of any consumable, BHEL reserves the right to procure the same from any source and recover the cost from the Contractor's first subsequent bill at market value plus the departmental charges of BHEL from time to time. Postponement of such recovery is normally not permitted. The decision of Engineer in this regard shall be final and binding on the Contractor.
4.1.9	All lubricants and chemicals required for pre-commissioning, commissioning, testing, preservation and lubricants for trial runs of the equipment shall be supplied by BHEL / BHEL's client. All services including labour and T&P will be provided by the contractor for handling, filling, emptying, refilling etc. The consumption of lubricants / chemicals shall be properly accounted for. Surplus material if any shall be properly stacked/ tagged and returned to BHEL/ CUSTOMER stores at no extra cost to BHEL. BHEL reserves the right to recover costs for wastage by the contractor.
4.1.10	Transportation of oil drums from stores, filling of oil for flushing, first filling, subsequent changeover if any; topping/making up till the unit is fully commissioned and handed over to customer is included in scope of this contract. The contractor shall have to return all the empty drums to BHEL / BHEL's client store at no extra cost. Any loss / damage to above drums shall be to contractor's account.
4.1.11	All charges on account of Octroi, terminal or sales tax and other duties on materials obtained from any source for carrying out the works in the scope of the contractor shall be borne by the contractor.
<b>4.2</b>	<b>TOOLS AND PLANTS / MONITORING AND MEASURING EQUIPMENT (MMEs)</b>
4.2.1	<b>T&amp;Ps and MMEs to be provided by Contractor</b>

SPECIAL CONDITIONS OF CONTRACT (SCC)

## Chapter - IV: Obligations of Contractor

4.2.1.1	All T&Ps and MMEs excepting those specifically indicated in BHEL scope are to be provided by the Contractor. Contractor has to make his own arrangement at his cost for completing the formalities (including arrangement of Road permits, if any) if required with Sales Tax/VAT authorities, for bringing their materials, plants and equipments at site for the execution of work under this contract.
4.2.1.2	All suitable cranes for erection of equipments, pipe lines, structural, unloading & loading and material handling, lifting and transport equipments for material handling at stores/yard/siding of BHEL/ Customer are included in contractor's scope. BHEL's cranes will not be available for this purpose unless otherwise specifically permitted as per contract conditions
4.2.1.3	All T&Ps to be deployed by the contractor shall have the approval of BHEL Engineer with regard to brand, quality and specification.
4.2.1.4	Indicative list of Major T&Ps in the scope of Contractor are given in the Technical Conditions of Contract. Bidders to note that these are only indicative and as such all other T&P necessary for timely and satisfactory completion of work in scope shall be mobilized by Contractor
4.2.1.5	Timely deployment of adequate T&Ps is the responsibility of the contractor. The contractor shall be prepared to augment the T&P at short notice to match the planned programme and to achieve the milestones.
4.2.1.6	Contractor shall maintain and operate his tools and plants in such a way that major breakdowns are avoided. In the event of major breakdown, contractor shall make alternative arrangements expeditiously so that the progress of work is not hampered.
4.2.1.7	In the event of contractor failing to arrange the required tools, plants, machinery, equipment, material or non-availability of the same owing to breakdown, BHEL will make alternative arrangement at the risk and cost of the contractor. Decision of BHEL shall be final and binding on the contractor
4.2.1.8	The T&P to be arranged by the contractor shall be in proper working condition and their operation shall not lead to unsafe condition. The movements of cranes and other equipment should be such that no damage / breakage occur to foundations, other equipments, material, property and men. All arrangements for the movement of the T&P etc. shall be the contractor's responsibility.
4.2.1.9	Use of welding generators / rectifiers only shall be permitted for welding. Use of welding transformers will be subject to specific approval of BHEL engineer.
4.2.1.10	The contractor at his cost shall carry out periodical testing of his construction equipments. Test certificates shall be furnished to BHEL.
4.2.1.11	Contractor shall ensure deployment of serviced and healthy T&Ps including cranes, lifting tackles, wire ropes, manila ropes, winches and slings etc. History card and maintenance records for major T&Ps will be maintained by the contractor and will be made available to BHEL Engineer for inspection as and when required. Fitness certificate / Test Certificates of T&P shall have to be submitted before it is put in use. Identification for such T&Ps will be done as per BHEL Engineer's advice. BHEL reserves the right to permit only new slings up to 20 mm and lifting tackles up to 3 MT capacities.
4.2.1.12	Contractor shall ensure deployment of reliable and calibrated MMEs (Inspection measuring and Monitoring equipment). The MMEs shall have test / calibration certificates from authorized / Government approved / accredited agencies traceable to National / International standards. Each MME shall have a label indicating calibration status i.e. date of calibration, calibration agency and due date for calibration. A list of such instruments deployed by contractor at site with its calibration status is to be submitted to BHEL Engineer for control.
4.2.1.13	Re-testing / re-calibration shall also be arranged at regular intervals during the period of use as advised by BHEL Engineer within the contract price. The contractor will also have alternate arrangements for such MME so that work does not suffer when the particular instrument is sent for calibration. If any MMEs not found fit for use, BHEL shall have the right to stop the use of such item. It will be necessary for the contractor to deploy proper item. Any readings taken by the defective instrument will be recalled and repeat the readings taken by that instrument with a proper one. In case he fails to do so, BHEL may deploy MMEs and retake the readings at contractor's cost.

SPECIAL CONDITIONS OF CONTRACT (SCC)

## Chapter - IV: Obligations of Contractor

4.2.1.14	BHEL shall have lien on all T&P, MMEs and other equipment of the contractor brought to the site for the purpose of erection, testing and commissioning. BHEL shall continue to hold the lien on all such items throughout the period of contract / extended period. The contractor and / or his sub-contractors, without the prior written approval of the Engineer, shall remove no material brought to the site.
4.2.1.15	The month wise T&P deployment plan to execute the work is to be submitted as per relevant format as per the instruction of BHEL. It shall be the contractor's responsibility to deploy the required T&P, for timely and successful completion of the job, to any extent.
4.2.2	<b>Obligations in respect of T&amp;Ps and MMEs if provided by BHEL</b>
4.2.2.1	T&P / MMEs being provided by BHEL to sub- contractor free of hire charges shall be shared by other subcontractors working for BHEL at site and the allotment done by BHEL Engineer shall be final and binding.
4.2.2.2	BHEL T&P will be issued in basic assembled condition. Additional loose components / sub-assemblies / attachments as and when necessary, will be issued by BHEL. Assembly of such additional loose components/sub-assemblies/ attachments is in contractor's scope.
4.2.2.3	In case of non-availability of the T&Ps to be provided by BHEL due to breakdown, major overhauls, distribution pattern or any other reason, the contractor shall plan / amend / alter his activities to meet erection / commissioning targets in consultation with BHEL.
4.2.2.4	<b>void</b>
4.2.2.5	The contractor shall engage trained and experienced operators for the operation of BHEL's T&Ps. Their skill / performance will be checked by BHEL Engineer before they are allowed to operate the same. However checking of skills by BHEL does not absolve the contractor of his responsibilities for proper and safe handling of equipment, consistent good performance of operators and regular performance evaluation of operators.
4.2.2.6	void
4.2.2.7	Void
4.2.2.8	Increasing / shortening of the crane boom to suit work requirements shall have to be arranged by the indenting contractor at his cost including restoration to a state as directed by BHEL. All necessary manpower tools, support, consumables, illumination etc. will have to be arranged by contractor at his cost. If required,
4.2.2.9	The area and infrastructure development of the area to be carried out by the customer. However, in construction projects of this magnitude it is possible that all the areas / approaches may not be ready. In such cases backfilling of approaches where ever necessary, consolidation of ground and arrangement of sleepers / sand bag filling etc., for safe operation / movement of equipment including cranes / trailers etc., shall be the responsibility of the contractor at his cost. No compensation on this account shall be payable.
4.2.2.10	Void
4.2.2.11	Void
4.2.2.12	Void
4.2.2.13	Void
4.2.2.14	Void
4.2.2.15	Void
4.2.2.17	Void.

SPECIAL CONDITIONS OF CONTRACT (SCC)

## Chapter 6 V: Responsibilities of Contractor in respect of Labour, Supervisory Staff, etc.

<b>5.0</b>	<b>RESPONSIBILITIES OF CONTRACTOR IN RESPECT OF LABOUR, SUPERVISORY STAFF, ETC.</b>
5.1	Refer relevant clauses of General Conditions of Contract (GCC) also in this regard
5.2	The contractor shall deploy all the necessary skilled, semiskilled, unskilled labour including highly skilled workmen etc. These workmen should have previous experience on similar job. They shall hold valid certificates wherever necessary. BHEL reserves the right to insist on removal of any employee of the contractor at any time if he is found to be unsuitable and the contractor shall forthwith remove him.
5.3	Contractor shall also comply with the requirements of local authorities/ project authorities calling for police verification of antecedents of the workmen, staff etc.
5.4	It is the responsibility of the contractor to engage his workmen in shifts and or on overtime basis for achieving the targets set by BHEL. This target may be set to suit BHEL's commitments to its customer or to advance date of completion of events or due to other reasons. The decision of BHEL in regard to setting the erection and commissioning targets will be final and binding on the contractor.
5.5	Contractor shall provide at different elevation suitable arrangement for urinal and drinking water facility with necessary plumbing & disposal arrangement including construction of septic tank. These installations shall be maintained in hygienic condition at all times.
5.6	The Contractor in the event of engaging 20 or more workmen, shall obtain Independent license under the Contract labour (Regulation and Abolition) Act 1970 from the concerned authorities based on Form-V issued by the Principal Employer/Customer. In order to issue Form-V by Customer, Contractor shall fulfill all Statutory requirements like Insurance Policy, PF Code/PF Account number etc. as per the requirement of BHEL/Customer.
5.7	Contractor shall deduct the necessary amount towards Provident Fund and contribute equal amount as per Government of India laws. This amount will be deposited regularly to the provident Fund Commissioner. BHEL/Customer may insist for submission of the account code duly certified by PF Commissioner.
5.8	Contractor may also be required to comply with provisions of ESI Act in vogue if applicable and submit evidence to BHEL.
5.9	BHEL / customer may insist for witnessing the regular payment to the labour. They may also like to verify the relevant records for compliance with statutory requirements. Contractor shall enable such facilities to BHEL / Customer.
5.10	Contractor shall deploy only qualified and experienced engineers/ supervisors. They shall have professional approach in executing the work.
5.11	The contractor's supervisory staff shall execute the work in the most professional manner in the stipulated time. Accuracy of work and aesthetic finish are essential part of this contract. They shall be responsible to ensure that the assembly and workmanship conform to dimensions and tolerances given in the drawings / instructions given by BHEL engineer from time to time.
5.12	The supervisory staff employed by the contractor shall ensure proper outturn of work and discipline on the part of the labour put on the job by the contractor. Also in general they should see that the works are carried out in a safe and proper manner and in coordination with other labour and staff employed directly by BHEL or other contractors of BHEL or BHEL's client.
5.13	It is the responsibility of the contractor to arrange gate pass for all his employees, T&P etc for entering the project premises. Necessary coordination with customer officials is the responsibility of the contractor. Contractor to follow all the procedures laid down by the customer for making gate passes. Where permitted, by customer / BHEL, to work beyond normal working hours, the contractor shall arrange necessary work permits for working beyond normal working hours.
5.14	The actual deployment of Labour and Engineer/supervision staff shall be so as to satisfy the erection and commissioning targets set by BHEL. If at any time, it is found that the contractor is not in a position to deploy the required engineers/supervisors/workmen due to any reason, BHEL shall have the option to make alternate arrangements at the contractor's risk and cost. The expenditure incurred along with BHEL overheads thereon shall be recovered from the contractor
5.15	Contractor shall not deploy women labour at night.

SPECIAL CONDITIONS OF CONTRACT (SCC)

## Chapter ó VI: Material Handling, Storage &amp; preservation

6.0	<b>MATERIAL HANDLING, STORAGE AND PRESERVATION ETC</b>
6.1	<b>MATERIAL HANDLING AND STORAGE</b>
6.1.1	All the equipments/materials furnished under this contract shall be received from the project stores, sheds / storage yards and transported to pre assembly area / erection site and stored in the storage spaces in a manner so that they are easily retrievable till the contractor erects them. <b>While drawing/lifting material from BHEL / customer stores, the contractor shall ensure that the balance / other materials are stacked back immediately. No claim is admissible on this account</b>
6.1.2	While BHEL will endeavor to store / stack / identify materials properly in their open / close / semi closed / tarpaulins covered storage yard / shed, it shall be contractor's responsibility to assist BHEL in identifying materials well in time for erection. They should take the delivery of the same, following the procedure indicated by BHEL, and transport the material safely to pre-assembly yard / erection site in time, according to program.
6.1.3	The contractor shall take delivery of components, equipment / consumables from storage area after getting the approval of BHEL Engineer on standard indent forms.
6.1.4	The contractor shall identify and deploy necessary Engineers / supervisors / workmen for the above work in sufficient number as may be needed by BHEL, for areas covering their scope.
6.1.5	All the equipment shall be handled very carefully to prevent any damage or loss. No untested wire ropes / slings etc. shall be used for unloading / handling. The equipment shall be properly protected to prevent damage either to the equipment or to the floor where they are stored. The equipment from the stores shall be moved to the actual location at the appropriate time so as to avoid damage of such equipment at site.
6.1.6	Contractor shall ensure that while lifting slings shall be put over the points indicated on the equipment or as indicated in the manufacturer's drawings. Slings / shackles of proper size shall be used for all lifting and rigging purposes. All care shall be taken to safe guard the equipment against any damage. Dragging of piping / valves should be avoided. In case of any damage the cost shall be covered from the contractor.
6.1.7	Approach road conditions from the stores / yards to the erection site may not be equipped and ideal for smooth transportation of the equipment. Contractor may have to be adequately prepared to transport the materials under the above circumstances without any extra cost. . The contractor may familiar himself with soil conditions at site.
6.1.8	Contractor shall be responsible for examining all the plant and materials issued to him and notify the Engineer immediately of any damage, shortage, discrepancy etc., before they are moved out of the stores / storage area. The contractor shall be solely responsible for any shortages or damages in transit, handling, storage and erection of the equipment once received by him. As the erection work will be spread in different areas / locations of the project, contractor has to arrange sufficient number of watch / ward personal to avoid any pilferage of material.
6.1.9	The contractor shall maintain an accurate and exhaustive record-detailing out the list of all equipment received by him for the purpose of erection and keep such record open for the inspection of the engineer at any time.
6.1.10	All the material in the custody of contractor and stored in the open or dusty locations must be covered with suitable weather proof / fire retardant covering material wherever applicable and shall be blocked up on raised level above ground. All covering materials including blocks and sleeper shall be arranged by the contractor at his cost.
6.1.11	If the material belonging to the contractor are stored in area other than those earmarked for his operation the engineer will have the right to get it moved to the area earmarked for the contractor at the contractors risk and cost.
6.1.12	The contractor shall be responsible for making suitable indoor storage facilities to store all equipment (drawn by the contractor from BHEL / customer stores), which require indoor storage till the time of their installation. The Engineer will direct the contractor in this regard, which item in his opinion will require indoor storage, and the contractor shall comply with Engineer's decision.

SPECIAL CONDITIONS OF CONTRACT (SCC)

## Chapter ó VI: Material Handling, Storage &amp; preservation

6.1.13	The contractor shall ensure that all surplus / damaged / scrap / unused material, packing wood / containers/ special transporting frames etc. are returned to BHEL at a place in project area identified by the Engineer. The contractor will maintain an account for all items received and returned to BHEL. Any shortage in returning such items shall be chargeable to the contractor except allowable wastage for packing wood only.
6.1.14	The contractor shall hand over all parts / materials remaining extra over the normal requirement with proper identification tags to the stores as directed by the concerned BHEL engineer.
6.1.15	The contractor shall ensure that all the packing materials and protective devices installed on equipment during transit and storage are removed before installation.
6.1.16	It shall be the responsibility of the contractor to keep the work / storage areas in neat, tidy and working conditions. All surplus/unusable packing and other materials shall be removed and deposited at location(s) specified by BHEL within the project premises. If required weighing of the same within the project premises will have to be carried out.
6.2	<b>PRESERVATION OF COMPONENTS</b>
6.2.1	After taking delivery from BHEL / customer's stores, plant materials storage shall be subjected to the following protection besides other provisions indicated in these specifications elsewhere.
6.2.1.1	Items stored outdoors shall be stacked up at least six inches (6") off the ground. Items should not be stored in a low lying area where water logging is a possibility. Contractor should have sufficient numbers of wooden / concrete / steel sleepers for the job.
6.2.1.2	Motors, valves, electrical equipment, control equipment and instruments, and special or precision items requiring special care, etc. shall be stored indoors. Motor windings shall be kept dry by use of external heat or space heaters.
6.2.1.3	Bearings and other wearing surfaces of plant materials shall be protected against corrosion and kept clean and should be regularly monitored.
6.2.1.4	Insulation materials shall be stored indoors or otherwise protected against getting wet/ damaged, using suitable measures and should be protected from direct rain.
6.2	<b>PRESERVATION OF COMPONENTS</b>
6.2.1	After taking delivery from BHEL / customer's stores, plant materials storage shall be subjected to the following protection besides other provisions indicated in these specifications elsewhere.
6.2.1.1	Items stored outdoors shall be stacked up at least six inches (6") off the ground. Items should not be stored in a low lying area where water logging is a possibility. Contractor should have sufficient numbers of wooden / concrete / steel sleepers for the job.
6.2.1.2	Motors, valves, electrical equipment, control equipment and instruments, and special or precision items requiring special care, etc. shall be stored indoors. Motor windings shall be kept dry by use of external heat or space heaters.
6.2.1.3	Bearings and other wearing surfaces of plant materials shall be protected against corrosion and kept clean and should be regularly monitored.
6.2.1.4	Insulation materials shall be stored indoors or otherwise protected against getting wet/ damaged, using suitable measures and should be protected from direct rain.
6.2.2	It shall be the responsibility of the contractor to apply preservatives / touch up paints (primer) on equipment handled and erected by him till such time of final painting. It shall be contractor's responsibility to arrange for required paints (primer), thinners, labour, scaffolding materials, cleaning materials like wire brush, emery sheets, etc., cleaning of surface and provide one coat of preservatives / paints (primer) from time to time as decided by BHEL engineer. The accepted rate shall include this work also. It is to be noted that such painting may have to be done as and when required till such time the final painting is carried out.
6.2.3	The contractor shall effectively protect the finished work from action of weather and from damage or defacement and shall cover the finished parts then and there for their protection.
6.2.4	Any failure on the part of contractor to carry out works according to above clauses will entail BHEL to carry out the job from any other party and recover the cost from contractor.

## SPECIAL CONDITIONS OF CONTRACT (SCC)

## Chapter ó VII: Drawings and documents

<b>7.0</b>	<b>DRAWINGS AND DOCUMENTS</b>
7.1	The detailed drawings, specifications available with BHEL engineers will be made available to the contractor during execution of work at site. The contractor will also ensure availability of all drawings / documents at work place.
7.2	Necessary drawings to carry out the erection work will be furnished to the contractor by BHEL on loan, which shall be returned to BHEL Engineer at site after completion of work. Contractor shall ensure safe storage and quick retrieval of these documents.
7.3	The contractor shall maintain a record of all drawings and documents available with him in a register as per format given by BHEL Engineer. Contractor shall ensure use of pertinent drawings / data / documents and removal of obsolete ones from work place and returning to BHEL.
7.4	The data furnished in various annexure enclosed with this tender specification are only approximate and for guidance. However, the change in the design and in the quantity may occur as is usual in any such large scale of work. The contractors quoted rates shall be inclusive of the above factor
7.5	Should any error or ambiguity be discovered in the specification or information the contractor shall forthwith bring the same to the notice of BHEL before commencement of work. BHEL's interpretation in such cases shall be final and binding on the contractor.
7.6	Deviation from design dimensions should not exceed permissible limit. The contractor shall not correct or alter any dimension / details, without specific approval of BHEL.

**SPECIAL CONDITIONS OF CONTRACT (SCC)****Chapter ó VIII: Inspection and Quality**

<b>8.0</b>	<b>INSPECTION AND QUALITY</b>
<b>8.1</b>	<b>Inspection, Quality Assurance, Quality Control</b>
8.1.1	Preparation of quality assurance log sheets and protocols with customer/ consultants/statutory authority, welding logs, NDE records, testing & calibration records and other quality control and quality assurance documentation as per BHEL engineer's instructions, is within the scope of work/specification. These records shall be submitted to BHEL/customer for approval from time to time.
8.1.2	The protocols between contractor and customer/ BHEL shall be made prior to installation for correctness of foundations, materials, procedures, at each stage of installation, generally as per the requirement of customer/ BHEL. This is necessary to ensure elimination of errors or keeping them within tolerable limits and to avoid accumulation and multiplication of errors.
8.1.3	A daily log book should be maintained by every supervisor/engineer of contractor on the job in duplicate (one for BHEL and one for contractor) for detailing and incorporating alignment/clearance / centering / leveling readings and inspection details of various equipments etc. High pressure welding details like serial number of weld joints, welders name, date of welding, details of repair, heat treatment etc. will be documented in welding log as per BHEL Engineer's instructions. Record of radiography containing details like serial number of weld joints, date of radiography, repairs, if any, re-shots etc. shall also be maintained as per BHEL Engineer's instructions. <b>Record of heat treatments performed shall be maintained as prescribed by BHEL</b>
8.1.4	The performance of welders will be reviewed from time to time as per the BHEL standards. Welders' performance record shall be periodically furnished for scrutiny of BHEL's Engineer. Corrective action as informed by BHEL shall be taken in respect of those welders not conforming to these standards. This may include removal/ discontinuance of concerned welder(s). Contractor shall arrange for the alternate welders immediately
8.1.5	All the welders shall carry identity cards as per the proforma prescribed by BHEL/ Customer/Consultant. Only welders duly authorized by BHEL/customer/consultant shall be engaged on the work.
8.1.6	Contractor shall provide all the Measuring Monitoring Equipments (MMEs) required for completion of the work satisfactorily. These MMEs shall be of brand, quality and accuracy specified by BHEL Engineer and should have necessary calibration and other certificates as per the requirement of BHEL Engineer. Decision of BHEL Engineer regarding acceptance or otherwise of the measuring instruments/gauges/tools for the work under this specification, is final and binding on the contractor. BHEL may give an indicative list of MMEs required for this work and to be made available by the contractor. The list will be reviewed by BHEL and the contractor shall meet any augmentation needed wherever required.
8.1.7	It is the responsibility of the contractor to prove the accuracy of the testing/measuring/calibrating equipments brought by him based on the periodicity of calibration as called for in the BHEL's quality assurance standards/BHEL Engineer's instructions.
8.1.8	Any re-laying or re-termination of cables/re-erection of instruments/ recalibration of instruments etc. required due to contractor's mistake or design requirement and found at any stage inspection, shall be carried out by the contractor at no extra cost.
8.1.9	BHEL have already been accredited with ISO 9001 certification and as such this work is subject to various audits to meet ISO 9001 requirements. One particular aspect which needs special mention is about arrangement of calibration of instruments by the contractor. Contractor shall ensure deployment of reliable and calibrated MMEs (Measuring and Monitoring Equipments). The MMEs shall have test / calibration certificates from authorized / Government approved / Accredited agencies traceable to National / International Standards. Re-testing / re- calibration shall also be arranged at regular intervals during the period of use as advised by BHEL Engineer within the contract price. The contractor will also have alternate arrangements for such MMEs so that work does not suffer when the particular equipment / instrument is sent for calibration. Also if any MMEs not found fit for use, BHEL shall have the right to stop the use of such item and instruct the contractor to deploy proper item and recall ie repeat the readings taken by that instrument, failing which BHEL may deploy MME and retake the readings at Contractor's cost.

SPECIAL CONDITIONS OF CONTRACT (SCC)Chapter ó VIII: Inspection and Quality

8.1.10	Re-work necessitated on account of use of invalid MMEs shall be entirely to the contractor's account. He shall be responsible to take all corrective actions, including resource augmentation if any, as specified by BHEL to make-up for the loss of time.
8.1.11	In the courses of erection, it may become necessary to carry repeated checks of the work with instruments recently calibrated, re-calibrated. BHEL may counter/ finally check the measurements with their own MMEs. Contractor shall render all assistance in conduct of such counter/final measurements.
8.1.12	Total Quality is the watchword of the work and Contractor shall strive to achieve the Quality Standards, procedures laid down by BHEL. He shall follow all the instructions as per BHEL drawings and Quality Standards.
8.2	<b>Stage Inspection By FES/QA Engineers</b>
8.2.1	Apart from day-to-day inspection by BHEL Engineers stationed at Site and Customer's Engineers, stage inspection of equipments under erection and commissioning at various stages shall also be conducted by teams of Engineers from Field Engineering Services of BHEL's Manufacturing Units, Quality Assurance teams from Field Quality Assurance, Unit/Factory Quality Assurance and Commissioning Engineers from Technical Services etc. Contractor shall arrange all labour, tools and tackles etc. along with proper access for such stage inspections free of cost.
8.2.2	Any modifications suggested by BHEL FES and QA Engineers's team shall be carried out by contractor.
8.3	<b>Statutory Inspection of Work</b>
8.3.1	<p>The work to be executed under these specifications has to be offered for inspection, at appropriate stages of work completion, to various statutory authorities for compliance with applicable regulations. The work related statutory inspections, though not limited to, are as under:</p> <ol style="list-style-type: none"> <li>1) Inspectorate of Steam Boilers and Smoke Nuisance</li> <li>2) Electrical Inspector</li> <li>3) Factory Inspector, Labour Commissioner, PF Commissioner and other authority connected to this project work</li> </ol> <p>The scope includes getting the approvals from the statutory authorities, which includes arranging for inspection visits of statutory authority periodically as per BHEL Engineer's instructions, arranging materials for ground inspection, taking rub outs for the pressure parts to be offered for inspection, submitting co-related inspection reports, documents, radiographs etc. and following up the matter with them. Contractor shall also make all arrangements for offering the Products / Systems for inspection at location, as applicable, to the concerned authority.</p>
8.3.2	Contractor should be qualified to execute pressure parts & piping work coming under the purview of IBR, for which he should register himself with CIB of state concerned. Contractor also should be aware of the latest IBR regulations and Electricity Act, including the amendments thereof.
8.3.3	Contractor shall comply with -Qualification Tests for welders engaged in welding of Boilers and Steam Pipes under Construction, Erection and Fabrication at Site in India and in repairing Boilers and steam pipes by welding's in line with Chapter XIII of Indian Boiler Regulations-1950, for testing his welders / men / workers, including all associated fees, procedures, required instruments and equipments and their calibration thereof, shall be contractor's responsibility to obtain approval of Statutory Authorities, wherever applicable, for the conducting of any work which comes under the purview of these authorities, at his cost.
8.3.4	<p>The following fees shall be excluded from scope of Contractor:</p> <ol style="list-style-type: none"> <li>1. Registration Fee as per Regulation 385 of Chapter IX of Indian Boiler Regulations-1950</li> <li>2. Fees for inspection of Boiler at the site of Construction as per Regulation 395 A, Sl. No. 4 of Chapter IX of Indian Boiler Regulations-1950</li> </ol> <p>However all other fees like visit fees charged by the Boiler Inspector and other arrangements for his visit or visits till satisfactory completion of work, shall be included in scope of Contractor</p>

## SPECIAL CONDITIONS OF CONTRACT (SCC)

## Chapter ó VIII: Inspection and Quality

8.4	The Quality Management System of BHEL- HPVP have already been certified and accredited under ISO 9002 standards in this regard. The basic philosophy of the Quality Management System is to define the organizational responsibility, work as per documented procedures, verify the output with respect to acceptance norms, identify the non-conforming product/ procedure and take corrective action for removal of non-conformance specifying the steps for avoiding recurrence of such non-conformities, & maintain the relevant quality records. The non-conformities are to be identified through the conduct of periodical audit of implementation of quality systems at various locations/stages of work. Suppliers/vendors of various products/services contributing in the work are also considered as part of the quality management system. .as such the contractor is expected not only to conform to the quality management system of BHEL but also it is desirable that they themselves are accredited under any quality management system standard.
8.5	<b>Field Quality Assurance</b>
8.5.1	Contractor shall carry out all activities conforming to the approved Field Quality Plan (FQP) as revised from time to time. Total quality shall be the watchword of the work and contractor shall strive to achieve the quality standards, procedures laid down by BHEL. He shall follow all the instructions as per BHEL drawings and quality standards. Contractor shall provide the services of quality assurance engineer as per the relevant clauses.

SPECIAL CONDITIONS OF CONTRACT (SCC)

## Chapter-IX: HSE &amp; OHSAS

9.0	<b>OCCUPATIONAL HEALTH, SAFETY &amp; ENVIRONMENT MANAGEMENT/ QUALITY ASSURANCE PROGRAMME:</b> BHEL, HPVP is certified for ISO 9001. Quality of work to customer's satisfaction and fulfillment of system requirements are the essence of ISO 9001 certification. BHEL, have HSE certification (ISO 14001 & OHSAS 18001) and therefore Contractor also shall organize/ plan/ perform all their activities to meet with the applicable requirements of these standards.
9.1	<b>HSE (Health, safety &amp; Environment):</b> Contractor will comply with HSE (Health, safety & Environment) requirements of BHEL. HSE requirements in brief, are given below :-
9.1.1	Contractor will nominate one of their qualified and experienced employees as Safety Officer, who will be responsible for all HSE related issues of contractor's work area. Safety Officer will have authority to stop any activity, in case he observes that the activity is not being carried out in safe manner. He will conduct surprise inspection as well as periodic inspection/drill (at least once in a month) and submit such reports to BHEL. He will conduct periodic meetings with supervisors of different working groups and explain HSE issues and use of PPEs to them. Reports of such meetings will be submitted to BHEL. Contractor will develop suitable work procedures based upon HSE guidelines and OCPs and implement it. Such work procedures will consist of Area of work, T&P Details, Work Procedure, and PPE requirements etc. Please refer Schedule VIII of BOCW Rules for number of safety officers, qualification, duties etc. Contractor should highlight the requirement of safety to staff and labor through daily tool box meeting before start of the day's job. Contractor to also submit monthly safety reports as per the format/procedure of BHEL.
9.1.2	The contractor shall arrange induction and regular health check of their employees as per schedule VII of BOCW rules by a registered medical practitioner. The contractor shall take special care of the employees affected with occupational diseases under rule 230 and schedule II of BOCW Rules. The employees not meeting the fitness requirement should not be engaged for such job
9.1.3	Following personnel protective equipments (PPEs), in adequate numbers, will be made available at site & their regular use by all concerned will be ensured: - - HELMET - SAFETY GOGGLES & WELDING FACE SHIELDS - SAFETY BELTS AND PROTECTIVE NET FOR WORKING AT HEIGHT - SAFETY SHOES - EAR PLUG - ANY OTHER SAFETY EQUIPMENT REQUIRED FOR SAFE COMPLETION OF THE WORK Contractor to also submit monthly reports on above as per the format/procedure of BHEL/ Consultant / customer.
9.1.4	Providing appropriate First Aid facilities for prompt treatment of injuries and illness at work place. Arranging training to contractor workmen/ employees for giving first aid.
9.1.5	Arranging ambulance in case of any emergency situation.
9.1.6	Identification of nearest hospital and health check-up of workmen/employees
9.1.7	Providing filtered drinking water at work place in cool container.
9.1.8	Providing Canteen, Rest Room, Washing facilities to the contracted employees as per provisions of Contract Labour Regulation Act 1970 (Chapter V).
9.1.9	Providing appropriate firefighting equipment at designated work place and nominate a fire officer/ warden adequately trained for his job.
9.1.10	Identification of nearest fire station and display contact telephone nos./ person's name around work places for cases of emergencies .
9.1.11	Providing adequate no. of 24 V sources and ensure that no hand lamps are operating at voltage level above 24 Volts.
9.1.12	Fulfilling safety requirements at all power tapping points.

SPECIAL CONDITIONS OF CONTRACT (SCC)

## Chapter-IX: HSE &amp; OHSAS

9.1.13	Red & White caution tape of proper width(1.5 to 2 inch) to be used for cordoning unsafe area such as open trench, excavation area etc.
9.1.14	Providing contractors company logo on cloths /uniform/ proper identity cards with photographs, for correct identification of people working at project site.
9.1.15	High/ Low pressure welders to be identified with separate colour clothings. No welders will be deployed without passing appropriate tests and holding valid welding certificates. Approved welding procedure should be displayed at work place.
9.1.16	Displaying safe handling procedures for all chemicals such as lube oil, acid, alkali, sealing compounds etc , at work place.
9.1.17	All scaffolding/ platforms should be made from materials of appropriate quality/grade so that these are safe for use. It should be certified/declared safe for use by an experienced contractor person, before any scaffolding/platform is used. Please refer IS:3696 part 1&2 and 4014 part 1 & 2
9.1.18	All T&Ps/ MMEs should be of reputed brand/appropriate quality & must have valid test/calibration certificates bearing endorsement from competent authority of BHEL. Contractor to also submit monthly reports of T&Ps deployed and validity test certificates to BHEL safety Officer as per the format/procedure of BHEL.
9.1.19	Ensure that the regulatory requirement of excessive weight limits (to carry/lift/ move weights beyond prescribed limits) for male and female workers are complied with.
9.1.20	Safety slogan, Safety/ Caution boards, wherever required to be displayed in consultation with BHEL.
9.1.21	Take suitable measures for waste management and environment related laws/legislation as a part of normal construction activities. Compliance with the legal requirements on storage/ disposal of paint drums (including the empty ones), Lubricant containers, Chemical Containers, and transportation and storage of hazardous chemicals will be strictly maintained. Ensure proper cleanliness of work place, housekeeping and waste management (including proper waste disposal ) on daily basis.
9.1.22	It is imperative on the part of the contractor to join and effectively contribute in joint measures such as tree plantation, environment protection, contributing towards social upliftment, conversion of packing woods to school furniture, keeping good relation with local populace etc.
9.1.23	The contractor shall carry out periodic air and water quality check and illumination level checking in his area of work place and take suitable control measure.
9.1.24	The Contractor is required to provide proper safety net systems (IS-11057) where ever the hazard of fall from height is present as per instruction of BHEL Engineer. The safety nets shall be fire resistant, duly tested and shall be of ISI Mark and the nets shall be located as per site requirements to arrest or to reduce the consequences of a possible fall of persons working at different heights.
9.1.25	Void..
9.2.	<b>SAFETY AND CLEANLINESS:</b> The contractor shall take all necessary safety precautions and arrange for appropriate appliances as per discretion of BHEL or its authorised officials (Site Construction Manager) to prevent loss of human lives, injuries, to personnel engaged and damage to property. Before commencing the work, the contractor shall submit a "Safety Plan" to the above authorised BHEL official and obtain approval on the same. The safety plan shall indicate in detail the measures that would be taken by the contractor to ensure safety of men, equipment, materials and environment during execution of the work. This will also include an organization structure, role and responsibilities of the concerned key personnel, the safety practices that will be followed, PPEs deployed, plan for handling critical activities and emergencies.
9.3	If the contractor fails to take appropriate safety precautions or to provide necessary safety devices and equipment or to carry out instructions issued by the authorised BHEL official, BHEL shall have the right to take corrective steps at the risk and cost of the contractor.
9.4	During the course of construction, alternation or repairs, scrap with protruding nail, sharp edge etc. and all other debris shall be kept clean from working areas, passage, ways and stairs in and around site.
9.5	Combustible scrap and debris shall be removed at regular intervals during the course of execution. Safe means shall be provided to facilitate such removal. The combustible scrap should be stored in safe place away from the plant materials to avoid fire accidents. The area shall be chosen in consultation with the Engineer and to be cordoned off.

**SPECIAL CONDITIONS OF CONTRACT (SCC)****Chapter-IX: HSE & OHSAS**

9.6	Rigging equipment for materials handling shall be inspected prior to use in each shift and as necessary during its use to ensure that it is safe. Defective rigging equipment will be removed from service.
9.7	Rigging equipment shall not be loaded in excess of its recommended safe working load. Rigging equipment, when not in use, shall be removed from the original work area so as not to present a hazard to employees.
9.8	Contractor shall notify the engineer, of his intention to bring on to site any equipment or any container, with liquid or gaseous fuel or other substance which may create a hazard. The Engineer shall have the right to prescribe the condition under which such equipment or container may be handled and used during the performance of the works and the contractor shall strictly adhere to such instructions. The Engineer shall have the right to inspect any construction tool and to forbid its use, if in his opinion it is unsafe. No claim due to such prohibition will be entertained.
9.9	Where it is necessary to provide and/or store petroleum products or petroleum mixture & explosives, the contractor shall be responsible for carrying out such provision / storage in accordance with the rules & regulations laid down in the relevant petroleum act, explosive act and petroleum and carbide of calcium manual, published by the chief inspector of explosives of India. All such storage shall have prior approval if necessary from the chief inspector of explosives or any other statutory authority. The contractor shall be responsible for obtaining the same.
9.10	Cylinders shall be moved by tilting and rolling them on their bottom edges. They shall not be intentionally dragged, struck or permitted to strike each other violently.
9.11	When cylinders are transported by powered vehicle they shall be secured in a vertical position.
9.12	All workmen of the contractor working on construction area shall wear safety shoes, hand gloves, safety helmets and safety belt as applicable. The contractor shall provide to its workforce and ensure the use of following personnel protective equipment as found necessary and as directed by BHEL.
9.12.1	Safety Helmets conforming to IS-2925 : 1984
9.12.2	Safety Belts conforming to IS-3521:1983
9.12.3	Safety Shoes conforming to IS-1989 : 1978
9.12.4	Eye and face protection devices conforming to IS 6 1179:1967, IS 5983:1980, IS 8521 Part 1:1977, IS 8521 Part 2: 1994.
9.12.5	Hand and body protection devices conforming to IS 4770:1991 and IS- 6994: Part 1: 1973, IS 6 8619 : 1977
9.12.6	Ear protection IS-9167:1979
9.12.7	Respiratory Protective Devices as per IS-9473:2002, i4746:1999 and 14166:1994
9.13	The contractor shall insure his workmen against all accidents and the policy shall be presented to BHEL Engineer on demand. Otherwise, BHEL will arrange the same and the expenditure towards this will be debited to the contractor. In case of a fatal or disabling injury accident to any person at construction site due to lapses by the contractor, the victim and/or his/her dependents shall be compensated by the contractor as per statutory requirements. However, if considered necessary BHEL shall have the right to impose appropriate financial penalty on contractor and recover the same from payments due to the contractor for suitably compensating the victim and/or his/her dependence before imposing any such penalty. Appropriate enquiry shall be held by BHEL giving opportunity to the contractor for presenting his case. Above safety conditions are not exhaustive but give an idea for the contractor and contractor shall adhere to all safety precaution given by the Engineer at site.
9.14	The contractor shall arrange at his cost adequate lighting facilities e.g. flood lighting, hand lamps, area lighting etc. at various levels for safe and proper working operations during night hours at the work spot as well as at the pre-assembly area.
9.15	The contractor shall be responsible for provision of all the safety notices and safety equipment as enjoined on him by the application of relevant statutory regulation / provisions and/or as called upon by BHEL from time to time. He shall be held responsible for any violation of statutory regulations (local, state or central) and BHEL instruction that may endanger safety of men, equipment and material.
9.16	The contractor shall provide temporary fencing wherever required as a safety measure against accident and damage to properties. Suitable caution notices shall be displayed where access to any part is found to be unsafe and hazardous.
9.17	Contractor shall ensure safety of all the workmen, material and equipment either belonging to him or to others working at site. He shall observe safety rules and codes applied by BHEL without exception.

SPECIAL CONDITIONS OF CONTRACT (SCC)

## Chapter-IX: HSE &amp; OHSAS

9.18	It will be the responsibility of the contractor to ensure safe lifting of the equipment, taking due precaution to avoid any accident and damage to other equipment and personnel. All requisite tests and inspection of handling equipment, tools & tackle shall be periodically done by the contractor by engaging only the COMPETENT PERSONS as per law. Defective equipment or uncertified shall be removed from service. Any equipment shall not be loaded in excess of its recommended safe working load.
9.19	The contractor shall provide necessary first aid facilities as per schedule III. In addition, ambulance facilities, OHC and CMO as per schedule IV, V, X and XI of BOCW Rules as applicable for all his employees, representatives and workmen at site and BHEL shall have no obligation in this regard. The first aid boxes should be placed at various elevations so as to make them available within the reach and at the quickest possible time. The contractor should conduct periodical first aid classes to keep his supervisor and Engineers properly trained for attending to any emergency.
9.20	Training
9.20.1	The contractor shall arrange induction safety training for all employees before assigning work. In addition, awareness programme, mock drill at regular intervals and daily tool box meetings shall be arranged. Monthly report of the above to be given to BHEL safety Officer as per prescribed BHEL formats.
9.20.2	All the contractor's supervisory personnel and sufficient number of workers shall be trained for fire protection systems. Enough number of such trained personnel must be available during the tenure of contract. Contractor should nominate his supervisor to coordinate and implement the safety measures.
9.21	Contractor shall provide enough fire protecting equipment of the types and numbers at his office, stores, temporary structure in labour colony etc. Such fire protection equipment shall be easy and kept open at all times. The fire extinguishers shall be properly refilled and kept ready which should be certified at periodic intervals. The date of changing should be marked on the Cylinders. All other fire safety measures as laid down in the codes for fire safety at construction site issued by safety coordinator of BHEL shall be followed. Non-compliance of the above requirement under fire protection shall in no way relieve the contractor of any of his responsibility and liabilities to fire accident occurring either to his materials or equipment or those of others. Emergency contacts nos must be displayed at prominent locations.
9.22	The contractor shall at his cost, remove from vicinity of work at least once each day all combustible waste, scrap, painting materials, rubbish, unused or other materials and deposit them in places specified by BHEL to keep the work site clear and tidy. Use of undercoated canvas paper, corrugated paper, fabricated carton, plastic or other flammable materials shall be restricted to the minimum and promptly removed.
9.23	The contractor shall not use any hand lamp energized by Electric power with supply voltage of more than 24 volts in confined spaces like inside water boxes, turbine casings, condensers etc.
9.24	All portable electric tools used by the contractor shall have safe plugging system to source of power and be appropriately earthed. Only electricians licensed by appropriate statutory authority shall be employed by the contractor to carry out all types of electrical works. Details of earth resource and their test dates to be given to BHEL safety officer as per the prescribed formats of BHEL.
9.25	In case of any delay in completion of a job due to mishaps attributable to lapses by the contractor, BHEL shall have the right to recover cost of such delay from the payments due to the contractor, after notifying the contractor suitably.
9.26	Valve protection caps shall be kept in place and secured.
9.27	The contractor shall be responsible for the safe storage and handling of his radio-active sources as per BARC rules and regulations.
9.28	Tarpaulin being inflammable should not be used (instead, only non-inflammable covering materials shall be used) as protective cover while preheating, welding, stress relieving etc. at site.

SPECIAL CONDITIONS OF CONTRACT (SCC)

## Chapter-IX: HSE &amp; OHSAS

9.29	If the contractor fails to improve the standards of safety in its operation to the satisfaction of BHEL after being given reasonable opportunity to do so and/or if the contractor fails to take appropriate safety precautions or to provide necessary safety devices and equipment or to carry out instruction regarding safety issued by BHEL, BHEL shall have the right to take corrective steps at the risk and cost of the contractor after giving a notice of not less than 7 days indicating the steps that would be taken by BHEL.
9.30	If the contractor succeeds in carrying out its job in time without any fatal or disabling injury accident and without any damage to property BHEL may, at its sole discretion, favorably consider to reward the contractor suitably for the performance.
9.31	The contractor shall carefully follow the safety requirement of BHEL/ the purchaser with the regard to voltages used in critical areas.
9.32	The contractor shall use only properly insulated and armored cables which conform to the requirement of Indian Electricity Act and Rules for all wiring, electrical applications at site. BHEL reserves the right to replace any unsafe electrical installations, wiring, cabling etc. at the cost of the contractor. All electrical appliances used in the work shall be in good working condition and shall be properly earthed. No maintenance work shall be carried out on live equipment. The contractor shall maintain adequate number of qualified electricians to maintain his temporary electrical installations. Area wise Electrical safety inspection is to be carried out on monthly basis as per Electrical Safety Inspection checklist and the report is to be submitted to BHEL safety officer.
9.33	The contractor shall arrange adequate number of persons specifically for clearing any debris and for housekeeping of the erection area including restacking of components in the erection areas. Housekeeping to be carried out as per BHEL's check list and report is to be submitted to BHEL safety officer.
9.34	In case of any damage to property due to lapses by the contractor, BHEL shall have the right to recover the cost of such damages from the contractor after holding an appropriate enquiry.
9.35	The contractor shall submit report of all accidents, fires and property damage etc. to the Engineer immediately after such occurrence, but in any case not later than 24 hours of the occurrence. Such reports shall be furnished in the manner prescribed by BHEL. In addition, periodic reports on safety shall also be submitted by the contractor to BHEL from time to time as prescribed by the Engineer. Compiled monthly reports of all kinds of accidents, fires and property damage to be submitted to BHEL safety officer as per prescribed formats
9.36	Before commencing the work, the contractor shall appoint / nominate a responsible person to supervise implementation of all safety measures and liaison with his counterpart of BHEL.
9.37	Suitable scaffolds shall be provided for workman for all works that cannot safely be done from the ground, or from solid construction except in the case of short duration of work which can be done safely from ladders. When a ladder is used, it shall be of rigid construction made of steel. The steps shall have a minimum width of 45 cm and a maximum rise of 30 cm. Suitable handholds of good quality wood or steel shall be provided and the ladder shall be given an inclination not steeper than ¼ horizontal and 1 vertical.
9.38	Scaffolding or staging more than 3.6 m above the ground floor, swung or suspended from an overhead support or erected with stationery support shall have a guard rail properly bolted, braced or otherwise secured, at least 90 cm above the floor or platform of such scaffolding or staging and extending along the entire length of the outside and ends thereof with only such openings as may be necessary for the delivery of materials. Such scaffolding or staging shall be so fastened as to prevent it from savor, from swaying, from the building or structure.
9.39	Working platforms, gangways and stairways shall be so constructed that they do not sag unduly or unequally and if the height of the platform gangways provided is more than 3.6 m above ground level or floor level, they shall be closely boarded and shall have adequate width which shall not be less than 750 mm and be suitably fenced as described above.
9.40	Every opening in the floor or a building or in a working platform shall be provided with suitable means to prevent the fall of persons or materials by providing suitable fencing or railing whose minimum height shall be 90 cm.

**SPECIAL CONDITIONS OF CONTRACT (SCC)****Chapter-IX: HSE & OHSAS**

9.41	Wherever there is open excavation in ground, they shall be fenced off by suitable railing and danger signals installed at night so as to prevent persons slipping into the excavations.
9.42	Safe means of access shall be provided to all working places. Every ladder shall be securely fixed. No portable single ladder shall be over 9 m in the length while the width between side rails in rung ladder shall in no case be less than app. 29.2 cm for ladder up to and including 3 m in length. For longer ladders this width shall be increased at least $\frac{1}{4}\phi$ for each additional foot of length.
9.43	A sketch of the ladders and scaffolds proposed to be used shall be prepared and approval of the Engineer obtained prior to Construction.
9.44	All personnel of the Contactor working within the plant site shall be provided with safety helmets. All welders shall wear welding goggles while doing welding work and all metal worker shall be provided with safety gloves. Persons employed on metal cutting and grinding shall wear safety glasses.
9.45	Adequate precautions shall be taken to prevent danger for electrical equipment. No materials on any of the sites of work shall be so stacked or placed as to cause danger or inconvenience to any person or the public.
9.46	All trenches, four feet or more in depth, shall at all times be supplied with at least one ladder for each 30 m in length or fraction thereof. The ladder shall be extended from bottom of the trench to at least 90 cm above the surface of the ground. Sides of the trenches which are 1.50 m or more in depth shall be stepped back to give suitable slope or securely held by timer bracing, so as to avoid the danger of sides collapsing. The excavated materials shall not be placed within 1.5 m of the edges of the trench or half of the depth of the trench whichever is more. Cutting shall be done from top to bottom. Under no circumstances undermining or undercutting shall be done.
9.47.1	The contractor shall take permission of BHEL prior to risky jobs such as working at height, hot work, lifting activities, etc. through permits. No job should be started without permits.
9.47.2	The Contactor shall take all measures at the sites of the work to protect all persons from accidents and shall be bound to bear the expenses of defense of every suit, action or other proceeding at law that may be brought by any persons for injury sustained or death owing to neglect of the above precautions and to pay any such persons such compensation or which may with the consent of the Contractor be paid to compromise any claim by any such person should such claim proceeding be filed against BHEL, the Contractor hereby agrees to indemnify BHEL against the same.
9.48	Before any demolition work is commenced and also during the process of the work the following shall be ensured:
9.48.1	All roads and open areas adjacent to the work site shall either be closed or suitably protected.
9.48.2	No electric cable or apparatus which is liable to be a source of danger nor a cable or an apparatus used by the operator shall remain electrically charged.
9.48.3	All practical steps shall be taken to prevent danger to persons employed from the risks of fire or explosion or flooding. No floor, roof or other part of the building shall be so overloaded with debris or materials as to render them unsafe.
9.49	All necessary personnel safety equipment as considered adequate by the Engineer should be kept available for the use of the persons employed in the Site and maintained in a condition suitable for immediate use and the Contactor should take adequate steps to ensure proper use of equipment by those concerned.
9.49.1	Workers employed on mixing asphalted materials, cement and lime mortars shall be provided with protective foot wear and protective goggles.
9.49.2	Those engaged in white washing and mixing or stacking of cement bags or any materials which are injurious to the eyes shall be provided with protective goggles.
9.49.3	Those engaged in welding works shall be provided with welder's protective eyesight lids
9.49.4	Stone breakers shall be provided with protective goggles and protective clothing and seated sufficient to safe intervals.

SPECIAL CONDITIONS OF CONTRACT (SCC)

## Chapter-IX: HSE &amp; OHSAS

9.49.5	Where workers are employed in sewers and manholes, which are in use, the Contractor shall ensure that the manhole covers are opened and ventilated at least for an hour before the workers are allowed to get into manhole, and the manholes so opened shall be cordoned off with suitable railing and provided with warning signals or boards to prevent accident to the public.
9.49.6	The Contractor shall not employ men below the age of 18 years and women on the work of painting with products containing lead in any form. Wherever men above the age of 18 are employed on the work of lead painting, the following precautions should be taken.
9.49.6.1	No paint containing lead or lead products shall be used except in the form of paste or readymade paint.
9.49.6.2	Suitably face masks should be supplied for use by the workers where paints are applied in the form of spray or a surface having lead paint dry rubbed and crapped.
9.49.6.3	Overalls shall be supplied by the Contractor to the workmen and adequate facilities shall be provided to enable the working painters to wash during the cessation of work.
9.50	When the work is being done near any place where there is risk of drowning all necessary equipment should be provided and kept ready for use and all necessary steps taken for prompt rescue of any person in danger and adequate provision should be made for prompt first aid treatment of all injuries likely to be sustained during the course of the work.
9.51	Motors, gearing, transmission, electric wiring and other dangerous parts of hoisting appliances should be provided with efficient safe guards. Hoisting appliance should be provided with such means as will reduce to the minimum the risk of any part of a suspended load becoming accidentally displaced. When workers employed on electrical installations which are already energized, insulting mats, wearing apparel, such as gloves, sleeves and boots as may be necessary should be provided. The worker should not wear any rings, watches and carry keys or other materials which are good conductor of electricity.
9.52	All scaffolds, ladders and other safety devices mentioned or described herein shall be maintained in safe condition and no scaffold, ladder or equipment shall be altered or removed while it is in use. Adequate washing facilities should be provided at or near the places of work.
9.53	The contractor shall maintain and ensure necessary safety measures as required for inspection and tests HV test, Pneumatic test, Hydraulic test, Spring test, Bend test etc as applicable, to enable Inspection Agency for performing Inspection. If any test equipment is found not complying with proper safety requirements then the Inspection Agency may withhold inspection, till such time the desired safety requirements are met.
9.54	The Contractor shall notify BHEL of his intention to bring to site any equipment or material which may create hazard. BHEL shall have the right to prescribe the conditions under which such equipment or materials may be handled and the contractor shall adhere to such instructions. BHEL may prohibit the use of any construction machinery, which according to him is unsafe. No claim for compensation due to such prohibition will be entertained by BHEL.
9.55	All safety precautions shall be taken for welding and cutting operations as per IS-818. All safety precautions shall be taken for foundation and other excavation marks as per IS-3764.
9.56	All gas cylinders shall be stored in upright position. Suitable trolley shall be used. There shall be flash-back arrestors conforming to IS-11006 at both cylinder and burner ends. Damaged tube and regulators must be immediately replaced. No of cylinders shall not exceed the specified quantity as per OCP
9.57	These safety provisions should be brought to the notice of all concerned by display on a notice board at a prominent, place at work spot. The persons responsible for compliance of the safety code shall be named therein by the Contractor
9.58	To ensure effective enforcement of the rules and regulations relating to safety precautions the arrangement made by the contract shall be open to inspection by the Engineer of the Engineer's Representative.

**SPECIAL CONDITIONS OF CONTRACT (SCC)****Chapter-IX: HSE & OHSAS**

9.59	Keeping the work area clean/ free from debris, removed scaffoldings, scraps, insulation/sheeting wastage /cut pieces, temporary structures, packing woods etc. will be in the scope of the contractor. Such cleanings have to be done by contractor within quoted rate, on daily basis by an identified group. If such activity is not carried out by contractor / BHEL is not satisfied, then BHEL may get it done by other agency and actual cost along with BHEL overheads will be deducted from contractor's bill. Such decisions of BHEL shall be binding on the contractor.																																																																		
9.60	Notwithstanding the above clauses there is nothing to exit the Contractor from the operations of any other Act or Rule in force in area of work in this respect. Provided always that all safety measures apart from those specifically provided in this agreement which are brought to the notice of the Contractor from time to time by the Engineer shall be complied by the Contractor. Provided further that all consequences, damages, or losses arising by reason of any safety code shall be met with by the Contractor.																																																																		
9.61	<p><b><u>NON COMPLIANCE: -</u></b></p> <p style="text-align: center;"><b>NONCONFORMITY OF SAFETY RULES AND SAFETY APPLIANCES WILL BE VIEWED SERIOUSLY AND BHEL HAS RIGHT TO IMPOSE FINES ON THE CONTRACTOR AS UNDER <u>for every instance of violation noticed:</u></b></p> <table border="1" data-bbox="253 842 1484 1843"> <thead> <tr> <th data-bbox="253 842 337 888">SN</th> <th data-bbox="337 842 1219 888">Violation of Safety Norms</th> <th data-bbox="1219 842 1484 888">Fine (in Rs)</th> </tr> </thead> <tbody> <tr> <td data-bbox="253 888 337 934">1</td> <td data-bbox="337 888 1219 934">Not Wearing Safety Helmet</td> <td data-bbox="1219 888 1484 934">50/- *</td> </tr> <tr> <td data-bbox="253 934 337 980">2</td> <td data-bbox="337 934 1219 980">Not wearing Safety Belt or not anchoring life line</td> <td data-bbox="1219 934 1484 980">100/-*</td> </tr> <tr> <td data-bbox="253 980 337 1026">3</td> <td data-bbox="337 980 1219 1026">Not wearing safety shoe</td> <td data-bbox="1219 980 1484 1026">100/-*</td> </tr> <tr> <td data-bbox="253 1026 337 1073">4</td> <td data-bbox="337 1026 1219 1073">Not keeping gas cylinders vertically</td> <td data-bbox="1219 1026 1484 1073">100/-</td> </tr> <tr> <td data-bbox="253 1073 337 1119">5</td> <td data-bbox="337 1073 1219 1119">Not using flash back arrestors</td> <td data-bbox="1219 1073 1484 1119">50/-</td> </tr> <tr> <td data-bbox="253 1119 337 1165">6</td> <td data-bbox="337 1119 1219 1165">Not wearing gloves</td> <td data-bbox="1219 1119 1484 1165">50/- *</td> </tr> <tr> <td data-bbox="253 1165 337 1211">7</td> <td data-bbox="337 1165 1219 1211">Grinding Without Goggles</td> <td data-bbox="1219 1165 1484 1211">50/- *</td> </tr> <tr> <td data-bbox="253 1211 337 1257">8</td> <td data-bbox="337 1211 1219 1257">Not using 24 V Supply For Internal Work</td> <td data-bbox="1219 1211 1484 1257">500/-</td> </tr> <tr> <td data-bbox="253 1257 337 1304">9</td> <td data-bbox="337 1257 1219 1304">Electrical Plugs Not used for hand Machine</td> <td data-bbox="1219 1257 1484 1304">100/-</td> </tr> <tr> <td data-bbox="253 1304 337 1350">10</td> <td data-bbox="337 1304 1219 1350">Not Slinging property</td> <td data-bbox="1219 1304 1484 1350">200/-</td> </tr> <tr> <td data-bbox="253 1350 337 1396">11</td> <td data-bbox="337 1350 1219 1396">Using Damaged Sling</td> <td data-bbox="1219 1350 1484 1396">200/-</td> </tr> <tr> <td data-bbox="253 1396 337 1442">12</td> <td data-bbox="337 1396 1219 1442">Lifting Cylinders Without Cage</td> <td data-bbox="1219 1396 1484 1442">500/-</td> </tr> <tr> <td data-bbox="253 1442 337 1488">13</td> <td data-bbox="337 1442 1219 1488">Not Using Proper Welding Cable With Lot of Joints And Not Insulated Property.</td> <td data-bbox="1219 1442 1484 1488">200/-</td> </tr> <tr> <td data-bbox="253 1488 337 1535">14</td> <td data-bbox="337 1488 1219 1535">Not Removing Small Scrap From Platforms</td> <td data-bbox="1219 1488 1484 1535">200/-</td> </tr> <tr> <td data-bbox="253 1535 337 1581">15</td> <td data-bbox="337 1535 1219 1581">Gas Cutting Without Taking Not Using Sheet Below Gas Cutting</td> <td data-bbox="1219 1535 1484 1581">200/-</td> </tr> <tr> <td data-bbox="253 1581 337 1627">16</td> <td data-bbox="337 1581 1219 1627">Not Maintaining Electric Operated Dangerously</td> <td data-bbox="1219 1581 1484 1627">500/-</td> </tr> <tr> <td data-bbox="253 1627 337 1673">17</td> <td data-bbox="337 1627 1219 1673">Improper Earthing Of Electrical T&amp;P</td> <td data-bbox="1219 1627 1484 1673">500/-</td> </tr> <tr> <td data-bbox="253 1673 337 1719">18</td> <td data-bbox="337 1673 1219 1719">No or improper barricading</td> <td data-bbox="1219 1673 1484 1719">500/-</td> </tr> <tr> <td data-bbox="253 1719 337 1766">19</td> <td data-bbox="337 1719 1219 1766">Activity carried out without Safety work permit (Height work, Lifting activity, Hot work-each person/case)</td> <td data-bbox="1219 1719 1484 1766">1000/-</td> </tr> <tr> <td data-bbox="253 1766 337 1812">20</td> <td data-bbox="337 1766 1219 1812">Accident Resulting in Partial Loss in Earning Capacity</td> <td data-bbox="1219 1766 1484 1812">25,000/- per victim</td> </tr> <tr> <td data-bbox="253 1812 337 1858">21</td> <td data-bbox="337 1812 1219 1858">Fatal Accident/Accidents Resulting in total loss in Earning Capacity</td> <td data-bbox="1219 1812 1484 1858">1,00,000/per victim #</td> </tr> </tbody> </table> <p data-bbox="164 1848 1529 2005">Legend: -*: per head, #: or as deducted by Customer whichever is higher. Any other non-conformity noticed not listed above will also be fined as deemed fit by BHEL. The decision of BHEL engineer is final on the above. The amount will be deducted from running bills of the contractor. The amount collected above will be utilized for giving award to the employees who could avoid accident by following safety rules. Also the amount will be spent for purchasing the safety appliances and supporting the safety activity at site.</p>	SN	Violation of Safety Norms	Fine (in Rs)	1	Not Wearing Safety Helmet	50/- *	2	Not wearing Safety Belt or not anchoring life line	100/-*	3	Not wearing safety shoe	100/-*	4	Not keeping gas cylinders vertically	100/-	5	Not using flash back arrestors	50/-	6	Not wearing gloves	50/- *	7	Grinding Without Goggles	50/- *	8	Not using 24 V Supply For Internal Work	500/-	9	Electrical Plugs Not used for hand Machine	100/-	10	Not Slinging property	200/-	11	Using Damaged Sling	200/-	12	Lifting Cylinders Without Cage	500/-	13	Not Using Proper Welding Cable With Lot of Joints And Not Insulated Property.	200/-	14	Not Removing Small Scrap From Platforms	200/-	15	Gas Cutting Without Taking Not Using Sheet Below Gas Cutting	200/-	16	Not Maintaining Electric Operated Dangerously	500/-	17	Improper Earthing Of Electrical T&P	500/-	18	No or improper barricading	500/-	19	Activity carried out without Safety work permit (Height work, Lifting activity, Hot work-each person/case)	1000/-	20	Accident Resulting in Partial Loss in Earning Capacity	25,000/- per victim	21	Fatal Accident/Accidents Resulting in total loss in Earning Capacity	1,00,000/per victim #
SN	Violation of Safety Norms	Fine (in Rs)																																																																	
1	Not Wearing Safety Helmet	50/- *																																																																	
2	Not wearing Safety Belt or not anchoring life line	100/-*																																																																	
3	Not wearing safety shoe	100/-*																																																																	
4	Not keeping gas cylinders vertically	100/-																																																																	
5	Not using flash back arrestors	50/-																																																																	
6	Not wearing gloves	50/- *																																																																	
7	Grinding Without Goggles	50/- *																																																																	
8	Not using 24 V Supply For Internal Work	500/-																																																																	
9	Electrical Plugs Not used for hand Machine	100/-																																																																	
10	Not Slinging property	200/-																																																																	
11	Using Damaged Sling	200/-																																																																	
12	Lifting Cylinders Without Cage	500/-																																																																	
13	Not Using Proper Welding Cable With Lot of Joints And Not Insulated Property.	200/-																																																																	
14	Not Removing Small Scrap From Platforms	200/-																																																																	
15	Gas Cutting Without Taking Not Using Sheet Below Gas Cutting	200/-																																																																	
16	Not Maintaining Electric Operated Dangerously	500/-																																																																	
17	Improper Earthing Of Electrical T&P	500/-																																																																	
18	No or improper barricading	500/-																																																																	
19	Activity carried out without Safety work permit (Height work, Lifting activity, Hot work-each person/case)	1000/-																																																																	
20	Accident Resulting in Partial Loss in Earning Capacity	25,000/- per victim																																																																	
21	Fatal Accident/Accidents Resulting in total loss in Earning Capacity	1,00,000/per victim #																																																																	

**SPECIAL CONDITIONS OF CONTRACT (SCC)**

**Chapter-IX: HSE & OHSAS**

9.61	<p><b><u>CITATION:</u></b>-If safety record of the contractor in execution of the awarded job is to the satisfaction of safety department of BHEL, issue of an appropriate certificate to recognize the safety performance of the contractor may be considered by BHEL after completion of the job.</p>
9.62	<p><b><u>MEMORANDUM OF UNDERSTANDING</u></b>                  After Award Of Work, Contractors Are Required To Enter Into A Memorandum Of Understanding As Given Below:</p> <p style="text-align: center;"><b><u>Memorandum of Understanding</u></b></p> <p>BHEL, Power Sector _____ Region is committed to Health, Safety and Environment Policy (EHS Policy).</p> <p>M/s _____ do hereby also commit to the same EHS Policy while executing the Contract Number _____</p> <p>M/s _____ shall ensure that safe work practices not limited to the above are followed by all construction workers and supervisors. Spirit and content therein shall be reached to all workers and supervisors for compliance.</p> <p>BHEL will be carrying out EHS audits twice a year and M/s _____ shall ensure to close any non-conformity observed / reported within fifteen days.</p> <p>Signed by authorized representative of M/s -----</p> <p>Name _____</p> <p>Place &amp; Date _____</p>

**SPECIAL CONDITIONS OF CONTRACT (SCC)****Chapter-X: RA Bill Payments**

<b>10.0</b>	<b>RA Bill Payments</b>
10.1	The contractor shall submit his monthly RA bills with all the details required by BHEL-HPVP on specified date every month covering progress of work in all respects and areas for the previous calendar month.
10.2	Mode of payment and measurement of work completed shall be as per relevant clauses of General Conditions of Contract
10.3	Release of payment in each running bill will be restricted to 90% of the value of work admitted as per stages of progressive pro rata payments.
10.4	The 10% thus remaining shall be treated as Retention Amount and shall be released as per terms specified in the General Conditions of Contract.
10.5	The payment for running bills will normally be released from BHE_HPVP Head Office at Visakhapatnam within 30 days of submission of running bill complete in all respects with all documents. It is the responsibility of the contractor to make his own arrangements for making timely payments towards labour wages, statutory payments, outstanding dues etc. and other dues in the meanwhile.
10.6	BHEL shall release payment through Electronic Fund Transfer (EFT)/RTGS from Head Office. In order to implement this system, Contractor to furnish details pertaining to his Bank Accounts where proceeds will be transferred through BHEL's banker, as per prescribed formats: Note: BHEL may also choose to release payment by other alternative modes as Applicable
10.7	Void

Document No PS:MSX:SCC, Rev 01 Chapter-X, Rev 00

**SPECIAL CONDITIONS OF CONTRACT (SCC)****Chapter-XI: Performance Monitoring**

<b>11.0</b>	<b>Performance Monitoring</b>
11.1	Performance of the contractor is monitored through various reports/reviews and shall be jointly evaluated every month for unit wise identified packages as per prescribed formats. Based on the net weighted scores obtained, Contractors shall be rated Good or Satisfactory or Unsatisfactory
11.2	In case of any dispute on performance rating and the contractor refuses to sign on the performance rating given by BHEL package In-charge, the same shall be reviewed by BHEL site In-charge/Construction Manager and his decision shall be final.
11.3	Void.
11.4	Performance of the contractor will be taken into consideration for assessing the capacity of the bidder to execute future jobs under tender, as detailed in the Notice Inviting Tender. Risk of non-evaluation or non-availability of the Monthly performance evaluation reports is to be borne by the Bidder.
11.5	In case of Unsatisfactory performance for a continuous period of three or more months for a package or packages, BHEL has the right to get the balance works executed at the risk and cost of the contractor.
11.6	In case of Unsatisfactory performance in a financial year, BHEL reserves the right to put on hold such Contractors for a period of six months for similar package or similar packages

Document No PS:MSX:SCC, Rev 01 Chapter-XI, Rev 00

**SPECIAL CONDITIONS OF CONTRACT (SCC)****Chapter-XII: Suspension of Business Dealings**

<b>12.0</b>	<b>Suspension of Business dealings</b>
12.1	BHEL reserves the right to take action against contractors who fail to perform or indulge in malpractices, by suspending business dealings with them.
12.2	Suspension could be in the form of <del>Hold</del> <del>De-listing</del> or <del>Banning</del> a contractor.
12.3	<p>A bidder may be put on HOLD for a period of 6 months, for future tenders for specific works on the basis of one or more of the following reasons:</p> <ol style="list-style-type: none"> <li>Bidder does not honour his own offer or any of its conditions within the validity period.</li> <li>Bidder fails to respond against three consecutive enquires of BHEL.</li> <li>After placement of order, Bidder fails to execute a contract.</li> <li>Bidder fails to settle sundry debt account, for which he is legitimately liable, within one year of its occurrence.</li> <li>Bidder's performance rating falls below 60% in specific category (more fully described in chapter <del>Performance Monitoring</del>)</li> <li>Bidder works are under strike/ lockout for a long period.</li> </ol>
12.4	<p>A Bidder may be de-listed from the list of registered Bidders of the region for a period of 1 year on the basis of one or more of the following reasons: -</p> <ol style="list-style-type: none"> <li>Bidder tampers with tendering procedure affecting ordering process or commits any misconduct which is contrary to business ethics.</li> <li>Bidder has substituted, damaged, failed to return, short returned or unauthorized disposed off materials/ documents/ drawings/ tools etc., of BHEL.</li> <li>Bidder no longer has the technical staff, equipment, financial resources etc. required to execute the orders/ contracts.</li> </ol>
12.5	<p>A Bidder can be banned from doing any business with all Units of BHEL for a period of 3 years on the basis of one or more of the following reasons:</p> <ol style="list-style-type: none"> <li>Bidder is found to be responsible for submitting fake/ false/ forged documents, certificates, or information prejudicial to BHEL's interest.</li> <li>In spite of warnings, the Bidder persistently violates or circumvents the provisions of labour laws/ regulations/ rules and other statutory requirements.</li> <li>Bidder is found to be involved in cartel formation</li> <li>The Bidder has indulged in malpractices or misconduct such as bribery, corruption and fraud, pilferage etc. which are contrary to business ethics.</li> <li>The Bidder is found guilty by any court of law for criminal activity/ offences involving moral turpitude in relation to business dealings.</li> <li>The Bidder is declared bankrupt, insolvent, has wound up or been dissolved; i.e. ceases to exist for all practical purposes.</li> <li>Bidder is found to have obtained Official Company information/ documentation by questionable means.</li> <li>Communication is received from the administrative Ministry of BHEL to ban the Bidder from business dealings.</li> </ol>
12.6	Contracts already entered with a contractor before the date of issue of order of <del>HOLD</del> or <del>DE-LISTING</del> shall not be affected.
12.7	All existing contracts with a <del>BANNED</del> contractor shall normally be short closed.
12.8	Once the order for suspension is passed, existing offers/new offers of the contractor shall not be entertained.
12.9	The above guidelines are not exhaustive but enunciate broad principles governing action against contractors

**BHARAT HEAVY ELECTRICALS LIMITED, HPVP UNIT, VISAKHAPATNAM  
PAINTING SCHEDULE FOR FEED HEATER, ONGC, NAVAGAM (SO:4051)  
DOCUMENT NO:4-4051-PAINT-SCH--001, REV: A**

S NO	DESCRIPTION	SURFACE PREPARATION & SURFACE PROFILE	PRIMER COAT		FINISH PAINT		Total DFT
			PAINT	NO OF COATS/DFT	PAINT	NO OF COATS/DFT	
1	External surfaces of Heater main shell/Economiser shell/stack/flue gas piping, structural members in contact with hot surfaces	SA2 1/2 Blast cleaning to near white metal SSPC-SP-10	F-9 Two pack air drying self curing solvent based inorganic zinc silicate coating with minimum 80% zinc on dry fill and suitable to 250 degree centigrade	1 coat 65-75 µ DFT/coat	F-12 Heat resistant silicon aluminium paint to IS13183 gr I suitable up to 250 degrees centigrade.	2 coat 20µ DFT/coat (2x20 µ)	105-115 µ
2	Heater inside surfaces in contact with ceramic fibre blanket	SA2 1/2 Blast cleaning to near white metal SSPC-SP-10	P6: One coat of self priming Epoxy phenolic primer.	1 coats 755 µ DFT/coat	Two coats of epoxy phenolic coating.	2 coats 75 µ DFT/coat	225 µ
3	<b>All other steel works</b>						
a)	Ladders, Rungs, Railing & Vertical posts	Power tool cleaning	F-9 Two component inorganic zinc silicate coating with minimum 80% zinc on dry film and suitable to 400 degrees centigrade + P6: One coat of Epoxy zinc phosphate primer.	1 coat 65-75 µ DFT/coat + 1 coats 40 µ DFT/coat	F6A: Two coats of epoxy high build paint. + F2: 1 coat of Acrylic Polyurethane finish paint	2 coats 100 µ DFT/coat + 1 coat 40 µ DFT/coat	345-355 µ
b)	Hand rail, middle rail, Toe plate,	SA2 1/2 Blast cleaning to near white metal SSPC-SP-10					
c)	Steel columns, brackets, duct outside, beams, bracings	SA2 1/2 Blast cleaning to near white metal SSPC-SP-10	F9: One coat of inorganic zinc silicate primer	1 coat 65-75 µ DFT/coat	F6A: 1coat of poly amine cured high build epoxy paint + F2: 1 coat of Acrylic Polyurethane finish paint	1 coats 100 µ DFT/coat + 1 coat 50 µ DFT/coat	215-225 µ
4)	Cold duct (In side)						

Notes: 1) All external insulated surfaces to be provided with primer coats only suitable for 40C degrees centigrade.  
2) For fabricated box sections & construction of similar nature, primer coat shall be given inside the surface before fabrication.  
3) \*\* SL No:2: Paint is in Refractory vendor scope.

Prepared by 

Checked by 

Approved by 

Ref: OPS/OS/WC/2019-20/117/016

Date: 23.05.2019

<b>MANPOWER DEPLOMENT SCHEDULE</b>		
<b>Sl. No</b>	<b>Description</b>	<b>Qty Required</b>
1	Site In charge with Power of Attorney	1 No.
2	Site Supervisor (Mechanical)	1 No.
3	Quality Engineer/Supervisor	1 No.
4	Qualified Safety Engineer/Supervisor	1 No.
6	Qualified Electrician	1 No.
7	Structural welder	2 Nos.
8	Pipe welder (6G position)	2 Nos.
9	Structure Fabricator/ Fitter	1 No
10	Pipe Fabricator/Fitter	1 No.
11	Skilled/ Semiskilled/ Unskilled manpower	As per site requirement

**SIGNATURE OF THE TENDERER WITH SEAL**

CONSTRUCTION MACHINERY DEPLOYMENT SCHEDULE		
Sl. No	Description	Qty Required
1	Hydra Crane 14T	1 No.
2	Higher Capacity Crane as per requirements	1 No.
3	Welding Machines	6 Nos.
4	TIG Welding set	2 Sets
5	Gas Cutting sets	3 Nos.
6	PUG Cutting Machines	2 Nos.
7	Grinding Machines	10 Nos.
8	Drilling Machines including Potable drilling Machine	2 Nos.
9	PMI Equipment	1 No.
10	NDT X-ray source & Camera	1 No.
11	Higher Capacity Slings as per requirement	8 Nos.
12	Higher Capacity D Shackles as per requirement	8 Nos.
13	Electrical distribution panel boards along with accessories	2 Nos.
14	Compressor, 350 CFT	1 No.
15	Hydraulic Test pump	1 No.
16	Electrode Backing Ovens	2 Nos.
17	Electrode Portable Ovens	12 Nos.
18	Trailer	1 No.
19	All other tools and tackles as per requirements	As per site requirement

**Note :** The list of machineries indicated above are tentative only. In addition to the above, if any other machineries and tools & tackles required for completion of the site works in all respects, then same are to be mobilised by the contractor without any additional cost.

**SIGNATURE OF THE TENDERER WITH SEAL**

**Ref: OPS/OS/WC/2019-20/117/016**

**Date: 23.05.2019**

**ACCEPTANCE TO TENDER TERMS & CONDITIONS**

**Sub:** Mechanical Contract for Dismantling of existing heater, Unloading & storage of materials, Fabrication, Erection, Testing, Painting of Heater Components and Its Auxiliaries and Providing manpower assistance for Pre-commissioning and Commissioning of Heater Package and Auxiliaries at M/s. ONGC, Navagam, Gujarat, SO No.-4051

**Tender Enquiry No.:** OPS/OS/WC/2019-20/117/016, Date: 23.05.2019

I / We hereby confirm that the Tender documents, all annexures etc. have been studied in detail and we have fully understood the scope of work.

I / We accept to all the Terms and Conditions of the Tender Enquiry and the prices quoted are in accordance with the same.

I / We accept to offer valid for a period of **6 months** from the last date for tender submission.

I / We give our acceptance to participate in Reverse Auction in case BHEL decides to go for reverse auction for this tender.

**Tender documents duly signed on all the pages by the Owner / authorized representative of the bidder are attached herewith.**

**SIGNATURE OF THE TENDERER WITH SEAL**

**CONTRACTOR INFORMATION**

Sl.No.	Particulars	To be Filled by Bidder
01.	Name of the Contractor	
02.	Nature of Firm / Concern (Proprietor/Partnership/Pvt. Limited/Public Ltd.) Note: In case of partnership concern, please enclose photo copies of the partnership deed	
03.	Full address	
04.	Name of the Proprietor/Partner	
05.	Name of the Person(s) and designation authorized for signing the contract/dealing with BHEL	
06.	Telephone No. of the firm	
07.	Fax No.	
08.	Mobile No.	
09.	E-mail ID	
09.	Organizational structure with name and designation	

SIGNATURE OF THE TENDERER WITH SEAL

**CHECK LIST**

Sl. No.	Particulars	Document Enclosed (Yes / No)	Document No
01.	Name of the Contractor		
02.	Tender Document Signed & Stamped		
03.	Earnest Money Deposit (EMD)		
04.	PF Registration Certificate		
05.	ESI Registration Certificate		
06.	GSTIN Registration Certificate		
07.	PAN Number		
08.	Income Tax Returns for last 3 years		
09.	Profit & Loss account and Balance Sheet certified by the Practicing Chartered Accountant for the last 3 years		
10.	Work orders & Job Completion Certificates in similar works as mentioned in eligibility criteria.		
11.	MSE Registration Documents, if applicable EM II certificate having deemed validity ( <b>or</b> ) Udyog Adhar Registration certificate		

SIGNATURE OF THE TENDERER WITH SEAL

**ACCEPTANCE FOR ELECTRONIC FUND TRANSFER / RTGS / NEFT TRANSFER**

01	NAME & ADDRESS OF THE SUPPLIER / SUBCONTRACTOR	
02	VENDOR CODE ASSIGNED BY BHEL, HPVP UNIT, VISAKHAPATNAM	

**DETAILS OF BANK ACCOUNT**

03	NAME & ADDRESS OF THE BANK	
04	NAME OF THE BRANCH	
05	BRANCH CODE	
06	MICR CODE	
07	ACCOUNT NUMBER	
08	TYPE OF ACCOUNT	
09	BENEFICIARY'S NAME	
10	IFSC CODE OF THE BRANCH	
11	EMAIL ID	
12	TELEPHONE / MOBILE NUMBER	

**CERTIFICATE**

I / We here by agree to receive the payments due from M/s Bharat Heavy Electricals Ltd., by the National Electronic Fund Transfer / or RTGS Transfer mode by credit to my / our above mentioned Bank account. I / We also agree that payments made to the above mentioned account are a valid discharge of the liability of M/s Bharat Heavy Electricals Ltd. I / We also agree to bear the applicable Bank charges for the above mode of transfer. A copy of the cheque leaf/ cancelled cheque leaf of the above account is sent herewith.

(Authorized Signatories with Name & Seal)

**BANKER'S CERTIFICATION**

We confirm that we are enabled for receiving RTGS and NEFT credits and we further confirm that the account number of \_\_\_\_\_ (name of account holder), the signature of authorized signatory and the MICR and IFSC codes of our branch mentioned above are correct.

Place:  
Date:

Bank Manager / Officer  
Signature with Bank stamp and name seal

**FORWARDED TO ACCOUNTS DEPARTMENT / CASH SECTION**

We confirm the above details are verified with the records available with us

Signature of BHEL Official with Name & Seal  
Operating the contract / Services

**GST COMPLIANCE FOR INDIGENOUS SUPPLIERS / CONTRACTORS**

1. In Response to Tenders for Indigenous supplier will be entertained only if the vendor has a valid GSTIN which should be clearly mentioned in the offer. If any specific exemption is available, a declaration with due supporting documents need to be furnished for considering the offer.
2. Supplier shall mention their GSTIN in all their invoices and invoices shall be in the format as specified/prescribed under GST laws. Invoices shall necessarily contain Invoice number (in case of multiple numbering system is being followed for billing like SAP invoice no, commercial invoice no etc., then the Invoice No which is linked/uploaded in GSTN network shall be clearly indicated), item description as per PO, Quantity, Rate, Value, applicable taxes with nomenclature (like IGST, SGST, CGST & UTGST) separately, HSN/ SAC Code, etc.
3. All invoices shall bear the HSN Code for each item separately (Harmonized System of Nomenclature)/ SAC code (Services Accounting Code).
4. A declaration to the effect that all invoice particulars are/were uploaded in the GSTN network/ portal & all tax liability as per GST rules and regulations have been and will be discharged, shall be mentioned in the invoice. If not mentioned in the invoice, a separate declaration shall be submitted as per the requirement of BHEL.
5. All documents like Test Certificate, LR copy, Guarantee/Warrantee certificate, work completion certificate, any other document mentioned in PO, shall be sent along with the vehicle/consignment where ever applicable. For all consignments received within the calendar month, input credit will be availed within that month in line with monthly returns filing cycle. In case of any discrepancy in the document or non-submission of documents mentioned in the PO, then BHEL will not be able to accept or account the material, in such case availing of tax credit will be deferred to next month or so.
6. In case of discrepancy in the data uploaded by supplier in the GSTN portal or in case of any shortages or rejection in the supply, then BHEL will not be able to avail the tax credit and will notify the supplier of the same. Supplier has to rectify the data discrepancy in the GSTN portal or issue credit note (details to be uploaded in GSTN portal) for the shortages or rejections in the suppliers, within the calendar month notified by BHEL.
7. For any such delay in availing of tax credit for reasons attributable to supplier (as mentioned above), interest (calculated @ SBI Base Rate + 6%) along with penalty if any will be deducted for the delayed period i.e. from the month of receipt till the month tax credit is availed, from the running bills.
8. Under GST regime, BHEL has to discharge GST liability on LD recovered from suppliers/contractors. Hence applicable GST shall also be recoverable from suppliers/contractors on LD amount. For this Debit note will be issued by BHEL indicating the respective supply invoice number.
9. This is to inform that GST portion of invoice, shall be released only upon Vendor declaring such invoice in his GSTR-1 and receipt of goods and Tax invoice by BHEL and Confirmation of payment of GST thereon by vendor on GSTN portal. Alternatively, BG of appropriate value may be obtained from vendor which shall be valid At least one month after the confirmation of date of payment of GST by vendor on GSTN portal and receipt of Tax invoice and receipt of goods, whichever is later. Above is subject to receipt of goods/service and tax invoice thereof along with vendor declaring invoice in his return and paying GST within timeline prescribed for availing ITC by BHEL.
10. That in case vendor delays Declaring such invoice in his return and GST credit availed by BHEL is denied or reversed subsequently as per GST law, GST amount paid by BHEL towards such ITC reversal as per GST law shall be recoverable from vendor/contractor along with interest levied/leviable on BHEL.

***Note: The above will be followed strictly for Processing vendor payments to ensure GST Compliance.***

**Form No: F- 01 (Rev 00)**  
**OFFER FORWARDING LETTER / TENDER SUBMISSION LETTER**  
(To be typed and submitted in the Letter Head of the Company/Firm of Bidder)

---

Offer Reference No:õ õ õ õ õ õ õ .

Date:õ õ õ õ õ

To,  
(Write Name & Address of Officer of BHEL inviting the Tender)

Dear Sir,

Sub : Submission of Offer against Tender Specification No: õ õ õ õ õ õ õ õ õ

I/We hereby offer to carry out the work detailed in the Tender Specification issued by Bharat Heavy Electricals Limited, HPVP, Visakhapatnam, in accordance with the terms and conditions thereof.

I/We have carefully perused the following listed documents connected with the above work and agree to abide by the same.

1. Amendments/ Clarifications/ Corrigenda/ Errata/ etc issued in respect of the Tender documents by BHEL
2. Notice Inviting Tender (NIT)
3. Price Bid
4. Technical Conditions of Contract
5. Special Conditions of Contract
6. General Conditions of Contract
7. Forms and Procedures

Should our Offer be accepted by BHEL for Award, I/we further agree to furnish ~~Security Deposit~~for the work as provided for in the Tender Conditions within the stipulated time as may be indicated by BHEL.

I/We further agree to execute all the works referred to in the said Tender documents upon the terms and conditions contained or referred to therein and as detailed in the appendices annexed thereto.

I/We have deposited/depositing herewith the requisite Earnest Money Deposit (EMD) as per details furnished in the Check List.

**Authorised Representative of Bidder**

Signature :

Name :

Address :

Place:

Date:

**Form No: F-02 (Rev 00)**

**DECLARATION BY AUTHORISED SIGNATORY OF BIDDER**

(To be typed and submitted in the Letter Head of the Company/Firm of Bidder)

-----

To,

(Write Name & Address of Officer of BHEL inviting the Tender)

Dear Sir,

Sub : **Declaration by Authorised Signatory**

Ref : 1) NIT/Tender Specification No: 0 0 0 0 0 0 0 0 0 ,

2) All other pertinent issues till date

I/We, hereby certify that all the information and data furnished by me with regard to the above Tender Specification are true and complete to the best of my knowledge. I have gone through the specifications, conditions, stipulations and all other pertinent issues till date, and agree to comply with the requirements and Intent of the specification.

I further certify that I am authorised to represent on behalf of my Company/Firm for the above mentioned tender and a valid Power of Attorney to this effect is also enclosed.

Yours faithfully,

(Signature, Date & Seal of Authorized Signatory of the Bidder)

Date:

Enclosed: Power of Attorney

**Form No: F-03 (Rev 00)**  
**NO DEVIATION CERTIFICATE**

(To be typed and submitted in the Letter Head of the Company/Firm of Bidder)

-----

To,  
(Write Name & Address of Officer of BHEL inviting the Tender)

Dear Sir,

Sub : **No Deviation Certificate**

Ref : 1) NIT/Tender Specification No: 0 0 0 0 0 0 0 0 0 ,

2) All other pertinent issues till date

We hereby confirm that we have not changed/ modified/materially altered any of the tender documents as downloaded from the website/ issued by BHEL and in case of such observance at any stage, it shall be treated as null and void.

We also hereby confirm that we have neither set any Terms and Conditions and nor have we taken any deviation from the Tender conditions together with other references applicable for the above referred NIT/Tender Specification.

We further confirm our unqualified acceptance to all Terms and Conditions, unqualified compliance to Tender Conditions, Integrity Pact (if applicable) and acceptance to Reverse Auctioning process.

We confirm to have submitted offer in accordance with tender instructions and as per aforesaid references.

Thanking you,

Yours faithfully,

(Signature, date & seal of authorized representative of the bidder)

**Form No: F-04 (Rev 00)**  
**DECLARATION CONFIRMING KNOWLEDGE ABOUT SITE CONDITIONS**  
(To be typed and submitted in the Letter Head of the Company/Firm of Bidder)

---

To,  
(Write Name & Address of Officer of BHEL inviting the Tender)

Dear Sir,

**Sub : Declaration confirming knowledge about Site conditions**

Ref : 1) NIT/Tender Specification No: 0 0 0 0 0 0 0 0 0 ,

2) All other pertinent issues till date

I/We, \_\_\_\_\_ hereby declare and confirm that we have visited the Project Site as referred in BHEL Tender Specifications and acquired full knowledge and information about the Site conditions including Wage structure, Industrial Climate, the Law & Order and other conditions prevalent at and around the Site. We further confirm that the above information is true and correct and we shall not raise any claim of any nature due to lack of knowledge of Site conditions.

I/We, hereby offer to carry out work as detailed in above mentioned Tender Specification, in accordance with Terms & Conditions thereof.

Yours faithfully,

(Signature, Date & Seal of Authorized  
Representative of the Bidder)

Date :

Place:

**CONTRACT AGREEMENT**

THIS AGREEMENT MADE THIS \_\_\_\_\_ DAY OF \_\_\_\_\_ between BHARAT HEAVY ELECTRICALS LIMITED (A Government of India Enterprise) a Company incorporated under the Companies Act, 1956, having its Registered Office at BHEL House, Siri Fort New Delhi- 110049 (herein after called BHEL) of the ONE PART.

AND

M/S \_\_\_\_\_ (hereinafter called the `Contractor') of the SECOND PART. Whereas M/s. \_\_\_\_\_ state that they have acquired and possess extensive experience in the field of \_\_\_\_\_ .

And Whereas in response to an Invitation to Tender No. \_\_\_\_\_ issued by BHEL for execution of the contractor submitted their offer No. \_\_\_\_\_ .

And whereas BHEL has accepted the offer \_\_\_\_\_ of the contractor on terms and conditions specified in the letter of intent no. \_\_\_\_\_ Dated.: \_\_\_\_\_ read with the reference.

THIS AGREEMENT WITNESSES AND it is hereby agreed by and between the parties as follows:

1. That the contractor shall execute the work of \_\_\_\_\_ and more particularly described in tender Specification No \_\_\_\_\_ including Drawings and Specifications (hereinafter called the said works) in accordance with and subject to terms and conditions contained in these presents, instructions to Tenderers, General Conditions of Contract, Special Conditions, Annexures, Letter of Intent dated \_\_\_\_\_ and such other instructions, Drawings, Specifications given to him from time to time by BHEL.
2. The Contractor is required to furnish to BHEL Security deposit in the form of cash/ approved securities / Bank Guarantee Valid up to \_\_\_\_\_ for a sum of Rs. \_\_\_\_\_ towards satisfactory performance and completion of the Contract.
3. The Contractor has furnished a Bank Guarantee bearing no.----- dated -----for a sum of Rs.----- executed by ----- in favour of BHEL towards Security Deposit valid up to -----

OR

The Contractor has furnished to BHEL an initial Security Deposit of Rs. \_\_\_\_\_ in the form of Cash/ approved Securities / B.G. No. \_\_\_\_\_ Dated \_\_\_\_\_ for Rs. \_\_\_\_\_ executed by \_\_\_\_\_ in favour of BHEL valid up to \_\_\_\_\_ and has agreed for recovery of the balance security deposit by BHEL @ 10% of the value of work done from each running bill till the entire Security Deposit is recovered.

OR

The contractor has furnished to BHEL an initial Security Deposit of Rs. \_\_\_\_\_ (Rs. \_\_\_\_\_ vide Bank Draft No. \_\_\_\_\_ Dated \_\_\_\_\_ and by adjusting EMD of Rs. \_\_\_\_\_ submitted vide Bank Draft No. \_\_\_\_\_ dated. \_\_\_\_\_) and has agreed for recovery of balance Security Deposit by BHEL @ 10% of the value of work done from each running bill till the entire security deposit is recovered.

The Contractor hereby agrees to extend the validity of the Bank Guarantee for such further period or periods as may be required by BHEL and if the Contractor fails to obtain such extension(s) from the Bank, the Contractor, shall pay forthwith or accept recovery of Rs.----- from the bills in one installment and the contractor further agrees that failure to extend the validity of the Bank Guarantee or failure to pay the aforesaid amount in the manner specified above shall constitute breach of contract. In addition to above, BHEL shall be entitled to take such action as deemed fit and proper for recovering the said sum of Rs. -----

OR

In case the contractor furnishes the bank guarantee at a later date the contractor hereby agrees to extend the validity of bank guarantee for such further period or periods as may be required by BHEL and if the contractor fails to obtain such extension(s) from the bank, the contractor shall pay forthwith or accept recovery of the amount of bank guarantee given in lieu of security deposit from the bills in one instalment and the contractor further agrees that failure to extend the validity of bank guarantee or failure to pay the aforesaid amount in the manner specified above shall constitute breach of contract. In addition to above, BHEL shall be entitled to take such action as deemed fit and proper for recovering the said sum.

4. That in consideration of the payments to be made to the Contractor by BHEL in accordance with this Agreement the Contractor hereby covenants and undertakes with BHEL that they shall execute, construct, complete the works in conformity, in all respects, with the terms and conditions specified in this Agreement and the documents governing the same.
5. That the Contractor shall be deemed to have carefully examined this Agreement and the documents governing the same and also to have satisfied himself as to the nature and character of the Works to be executed by him.
6. That the Contractor shall carry out and complete the execution of the said works to the entire satisfaction of the Engineer or such other officer authorised by BHEL, within the agreed time schedule, the time of completion being the essence of the Contract.
7. That BHEL shall, after proper scrutiny of the bills submitted by the Contractor, pay to him during the progress of the said works such sum as determined by BHEL in accordance with this Agreement.
8. That this Agreement shall be deemed to have come into force from ----- the date on which the letter of intent has been issued to the Contractor.
9. That whenever under this contract or otherwise, any sum of money shall be recoverable from or payable by the Contractor, the same may be deducted in the manner as set out in the General Conditions of Contract or other conditions governing this Agreement.
10. That all charges on account of Octroi, Terminal and other taxes including sales tax or other duties on material obtained for execution of the said works shall be borne and paid by the Contractor.
11. That BHEL shall be entitled to deduct from the Contractor's running bills or otherwise Income Tax under Section 194 (C) of the Income Tax Act, 1961.
12. That BHEL shall be further entitled to recover from the running bills of the Contractor or otherwise such sum as may be determined by BHEL from time to time in respect of consumables supplied by BHEL, hire charges for tools and plants issued (Where applicable) and any other dues owed by the Contractor.
13. That it is hereby agreed by and between the parties that non- exercise, forbearance or omission of any of the powers conferred on BHEL and /or any of its authorities will not in any manner constitute waiver of the conditions hereto contained in these presents and the liability of the Contractor with respect to compensation payable to BHEL or Contractor's obligations shall

remain unaffected.

14. It is clearly understood by and between the parties that in the event of any conflict between the Letter of Intent and other documents governing this Agreement, the provisions in the Letter of Intent shall prevail.

15. The following documents

a) Invitation to Tender No----- and the documents specified therein.

b) Contractor's Offer No----- dated-----.

c) \_\_\_\_\_

d) \_\_\_\_\_

e) \_\_\_\_\_

f) Letter of Intent No\_\_\_\_\_ dated\_\_\_\_\_.

g) \_\_\_\_\_

shall also form part of and govern this Agreement.

IN WITNESS HEREOF, the parties hereto have respectively set their signatures in the presence of

WITNESS

(CONTRACTOR)

(to be signed by a person holding a valid Power of Attorney)

1.

2.

WITNESS

(For and on behalf of BHEL)

1.

2.

**PROFORMA OF BANK GUARANTEE (in lieu of SECURITY DEPOSIT)**

In consideration of Bharat Heavy Electricals Limited (hereinafter referred to as the 'Employer' which expression shall unless repugnant to the context or meaning thereof, include its successors and permitted assigns) incorporated under the Companies Act, 1956 and having its registered office at \_\_\_\_\_ **1** through its Unit at \_\_\_\_\_ ..(name of the Unit) having agreed to exempt ( Name of the Vendor / Contractor / Vendors) with its registered office at \_\_\_\_\_ **2** (hereinafter called the said %Contractor+which term includes vendors), from demand under the terms and conditions of the Contract reference No. \_\_\_\_\_ dated \_\_\_\_\_ **3** valued at Rs \_\_\_\_\_ **4** ( Rupees -----) **4** (hereinafter called the said Contract), of Security Deposit for the due fulfilment by the said Contractor of the terms and conditions contained in the said Contract, on production of a Bank Guarantee for Rs. \_\_\_\_\_ **5** (Rupees \_\_\_\_\_ only),

We \_\_\_\_\_ (indicate the name and address of the Bank) having its Head Office at \_\_\_\_\_ (address of the head Office) (hereinafter referred to as the Bank), , at the request of \_\_\_\_\_ [Contractor(s)], being the Guarantor under this Guarantee, do hereby irrevocably and unconditionally undertake to forthwith and immediately pay to the Employer, , an amount not exceeding Rs. \_\_\_\_\_ without any demur, immediately on demand from the Employer and without any reservation, protest, and recourse and without the Employer needing to prove or demonstrate reasons for its such demand

Any such demand made on the bank, shall be conclusive as regards the amount due and payable by the Bank under this guarantee. However, our liability under this guarantee shall be restricted to an amount not exceeding Rs. \_\_\_\_\_.

We undertake to pay to the Employer any money so demanded notwithstanding any dispute or disputes raised by the Contractor(s) in any suit or proceeding pending before any Court or Tribunal or Arbitrator or any other authority, our liability under this present being absolute and unequivocal.

The payment so made by us under this guarantee shall be a valid discharge of our liability for payment hereunder and the Contractor(s) shall have no claim against us for making such payment.

We, further agree that the guarantee herein contained shall remain in full force and effect during the period that would be taken for the performance of the said Contract and that it shall continue to be enforceable till all the dues of the Employer under or by virtue of the said Contract have been fully paid and its claims satisfied & the Employer certifies that the terms and conditions of the said Contract have been fully and properly carried out by the said contractor(s) or acceptance of the final bill or discharge of this guarantee by the Employer, whichever is earlier. This guarantee shall initially remain in force up to and including \_\_\_\_\_ **6** and shall be extended from time to time for such period as may be desired by the Employer. Unless a demand or claim under this guarantee is made on us in writing on or before the \_\_\_\_\_ **7**, we shall be discharged from all the liability under this guarantee thereafter.

We, \_\_\_\_\_ (indicate the name of the Bank) \_\_\_\_\_ further agree with the Employer that the Employer shall have the fullest liberty without our consent and without affecting in any manner our obligations hereunder to vary any of the terms and conditions of the said Contract or to extend time of

performance by the said contractor(s) from time to time or to postpone for any time or from time to time any of the powers exercisable by the Employer against the said contractor(s) and to forbear or enforce any of the terms and conditions relating to the said Contract and we shall not be relieved from our liability by any reason of any such variation or extension being granted to the said contractor(s) or for any forbearance, act or omission on the part of the Employer or any indulgence by the Employer to the said contractor(s) or by any such matter or thing whatsoever which under the law relating to sureties would but for this provision have effect of so relieving us.

The Bank also agrees that the Employer at its option shall be entitled to enforce this Guarantee against the Bank as a principal debtor, in the first instance without proceeding against the Contractor and notwithstanding any security or other guarantee that the Employer may have in relation to the Contractor's liabilities.

This Guarantee shall not be determined or affected by liquidation or winding up, dissolution or change of constitution or insolvency of the Contractor but shall in all respects and for all purposes be binding and operative until payment of all money payable to the Employer in terms thereof. This guarantee will not be discharged due to the change in the constitution of the Bank or the Contractor(s).

We, \_\_\_\_\_ . BANK lastly undertake not to revoke this guarantee during its currency except with the previous consent of the Employer in writing.

Notwithstanding anything to the contrary contained hereinabove:

- a) The liability of the Bank under this Guarantee shall not exceed \_\_\_\_\_ 5
- b) This Guarantee shall be valid up to \_\_\_\_\_ 6
- c) Unless the Bank is served a written claim or demand on or before \_\_\_\_\_ 7 all rights under this guarantee shall be forfeited and the Bank shall be relieved and discharged from all liabilities under this guarantee irrespective of whether or not the original bank guarantee is returned to the Bank.

We, \_\_\_\_\_ Bank, have power to issue this Guarantee under law and the undersigned as a duly authorized person has full powers to sign this Guarantee on behalf of the Bank.

Date \_\_\_\_\_ Day of \_\_\_\_\_  
for \_\_\_\_\_ (indicate the name of the Bank)

(Signature of Authorised signatory)

- 1 ADDRESS OF THE EMPLOYER. i.e. Bharat Heavy Electricals Limited
- 2 ADDRESS OF THE VENDOR /CONTRACTOR / SUPPLIER.
- 3 DETAILS ABOUT THE NOTICE OF AWARD/CONTRACT REFERENCE
- 4 CONTRACT VALUE
- 5 BG AMOUNT IN FIGURES AND WORDS
- 6 VALIDITY DATE
- 7 DATE OF EXPIRY OF CLAIM PERIOD

**Note:**

1. Units are advised that expiry of claim period may be kept 3-6 months after validity date. It may be ensured that the same is in line with the agreement/ contract entered with the Vendor.
2. The BG should be on Non-Judicial Stamp paper/e-stamp paper of appropriate value as per Stamp Act prevailing in the State(s) where the BG is submitted or is to be acted upon or the rate prevailing in the State where the BG was executed, whichever is higher. The Stamp Paper/e-stamp paper shall be purchased in the name of Vendor/Contractor/Supplier /Bank issuing the guarantee.
3. In line with the GCC, SCC or contractual terms, Unit may carry out minor modifications in the Standard BG Formats. If required, such modifications may be carried out after taking up appropriately with the Unit/ Region's Law Deptt.

**4. In Case of Bank Guarantees submitted by Foreign Vendors**

- a) From Nationalized/Public Sector / Private Sector/ Foreign Banks (BG issued by Branches in India) can be accepted subject to the condition that the Bank Guarantee should be enforceable in the town/city or at nearest branch where the Unit is located i.e. Demand can be presented at the Branch located in the town/city or at nearest branch where the Unit is located.
- b) From Foreign Banks (wherein Foreign Vendors intend to provide BG from local branch of the Vendor Country's Bank)

**b.1** In such cases, in the Tender Enquiry/ Contract itself, it may be clearly specified that Bank Guarantee issued by any of the Consortium Banks only will be accepted by BHEL. As such, Foreign Vendor needs to make necessary arrangements for issuance of Counter- Guarantee by Foreign Bank in favour of the Indian Bank's (BHEL's Consortium Bank) branch in India. It is advisable that all charges for issuance of Bank Guarantee/ counter- Guarantee should be borne by the Foreign Vendor. The tender stipulation should clearly specify these requirements.

**b.2** In case, Foreign Vendors intend to provide BG from Overseas Branch of our Consortium Bank (e.g. if a BG is to be issued by SBI Frankfurt), the same is acceptable. However, the procedure at sl.no. b.1 will required to be followed.

**b.3** The BG issued may preferably be subject to Uniform Rules for Demand Guarantees (URDG) 758 (as amended from time to time). The BG Format provided to them should clearly specify the same.

**Indemnity Bond**

Form No: F-21 Rev 0

(To be executed on a Non Judicial Stamp Paper of the requisite value as per Stamp Duty prevalent in the respective State)

This Indemnity Bond executed by <name of company> having their Registered Office at <XXXXXXXXXXXX> in favour of M/s Bharat Heavy Electricals Limited, a Company incorporated under the Companies Act, 1956, having its Registered Office at BHEL House, Siri Fort, Asiad, New Delhi - 110049 through its Unit at Power Sector \_\_\_\_\_ Region \_\_\_\_\_ State. (Hereinafter referred to as the Company)

And whereas the Company has entered into a Contract with M/s \_\_\_\_\_ the executants of this Deed (hereinafter referred to as the Contractor) as its contractor in respect of the work of %o \_\_\_\_\_ +

AND WHEREAS under the provisions of GCC further stipulates that the Contractor shall indemnify the Company against all claims of whatever nature arising during the course of execution of Contract including defects liability period of \_\_\_\_\_ Months, i.e. till Date.: \_\_\_\_\_.

Now this deed witness that in case the Company is made liable by any Authority including Court to pay any claim or compensation etc. in respect of all labourers or other matters at any stage under or relating to the Contract with the Contractor, the Contractor hereby covenants and agrees with the Company that they shall indemnify and reimburse the Company to the extent of such payments and for any fee, including litigation charges, lawyers fees, etc., penalty or damages claimed against the Company by reason of the Contractor falling to comply with Central/States Laws, Rules etc, or his failure to comply with Contract (including all expenses and charges incurred by the Company).

The Contractor further indemnifies the Company for the amount which the Company may be liable to pay by way of penalty for not making deductions from the Bills of the Contractor towards such amount and depositing the same in the Government Treasury.

The Contractor further agree that the Company shall be entitled to withhold and adjust the Security Deposit and/or withhold and adjust payment of Bills of Contractor pertaining to this Contract against any payment which the Company has made or is required to make for which the Contractor is liable under the Contract and that such amount can be withheld, adjusted by the Company till satisfactory and final settlement of all pending matters and the Contractor hereby gives his consent for the same.

The Contractor further agrees that the terms of indemnity shall survive the termination or completion of this contract.

The contractor further agrees that the liability of the contractor shall be extended on actual basis notwithstanding the limitations of liability clause, in respect of:

1. breach of terms of contract by the contractor
2. breach of laws by the contractor
3. breach of Intellectual property rights by the contractor

4. breach of confidentiality by the contractor

Nothing contained in this deed, shall be construed as absolving or limiting the liability of the Contractor under said Contract between the Company and the Contractor. That this Indemnity Bond is irrevocable and the condition of the bond is that the Contractor shall duly and punctually comply with the terms and the conditions of this deed and contractual provisions to the satisfaction of the Company.

In witness where of M/s \_\_\_\_\_ these presents on the day, month and year first, above written at \_\_\_\_\_ by the hand of its signatory Mr. \_\_\_\_\_.

Signed for and on behalf of

M/s \_\_\_\_\_

Witness:

1

2

Form No: F-25 Rev 0

**POWER OF ATTORNEY for SUBMISSION OF TENDER/SIGNING CONTRACT AGREEMENT**

(To be typed on non judicial Stamp Papers of appropriate value as applicable and Notarized)

KNOW ALL MEN BY THESE PRESENTS, that I/We do hereby make, nominate, constitute and appoint Mr. \_\_\_\_\_, whose signature given below herewith to be true and lawful Attorney of M/s \_\_\_\_\_ hereinafter called ~~Company~~ for submitting Tender/entering into Contract and inter alia, sign, execute all papers and to do necessary lawful acts on behalf of Company with M/s Bharat Heavy Electricals Ltd, Power Sector \_\_\_\_\_ Region, \_\_\_\_\_, in connection with \_\_\_\_\_ vide Tender Specification No: \_\_\_\_\_ dated \_\_\_\_\_

And the Company do hereby agree to ratify and confirm all acts, deeds, things or proceedings as may be lawfully done by the said attorney and by or on behalf of the company and in the name of the company, by virtue of the powers conferred herein and the same shall be binding on the company and shall have full force and effect.

IN WITNESS WHEREOF the common seal of the company has been hereunto affixed in the manner hereinafter appearing on the document.

Dated at \_\_\_\_\_, this \_\_\_\_\_ day of \_\_\_\_\_

\_\_\_\_\_ Director/CMD/Partner/Proprietor

Signature of Mr. \_\_\_\_\_ (Attorney)

Attested by: Director/CMD/Partner/Proprietor

Witness

Notary Public

## Statutory Requirements

### (Extract from Contract with Customer)

Wherever applicable, the contractor shall have itself registered under Employees Provident Fund and Miscellaneous Provisions Act, 1952 and Employees State Insurance Act, 1948 and follow the relevant statutory provisions including Rules made there-under concerning contractual workers.

The contractor shall be required to submit the following documents/ details to the Corporation.:

- (i) Copy of PF-ECR duly stamped by the designated Bank, along with a print of the digitally signed PDF data sheet of the ECR, as proof of payment, each month, details of this PDF data sheet shall be verified by the appropriate authority (i.e. Payment Making Authority) in the Corporation from the official website of EPFO (<http://www.epfindia.gov.in>).
- (ii) (A) Copy of the online challan endorsed/ stamped by the designated bank as proof of receipt of payment towards monthly contribution of ESI contribution.  
(B) Copy of Returns of contribution in respect of ESI for each contribution period of the six months i.e. for the contribution period ended 30<sup>th</sup> Sept and the contribution ended 31<sup>st</sup> March.
- (iii) As an Annexure to each EPF-ECR and ESI Challan(s), contractor shall also furnish the following certificates.
  - a. The furnished information is correct to the best of his knowledge.
  - b. In case any discrepancies or irregularities is / are noticed in this undertaking, then ONGC is free to inform the PF/ ESIC Authorities.
  - c. Before the completion of contract, contractor shall serve one-month notice to all his contractual workers, informing that their services will be terminated.
  - d. Within one month on completion / expiry of the contract, contractor shall pay all the dues/ terminal dues such as leave with wages, bonus (if applicable), Gratuity (if applicable), to all his contractual workmen, failing which contractor's Bank Guarantee/ Security Deposit may be withheld by ONGC.

Corporation shall maintain these records and verify the deposit of statutory contribution made by the contractor with the EPF/ ESI authorities. Where deemed necessary. However, (i.e. Payment Making Authority) in the Corporation, shall verify the details/ status of the payment towards EPF/ ESI (i.e. <http://www.epfindia.gov.in> AND <http://esic.in>). In case the information furnished by the Contractor is found to be incorrect the corporation shall take appropriate action against the contract.

**Note:** Conditions for applicability of above provisions

Above clause W.R.T. submission of details of EPF and ESI payments shall not be applicable in following types of contracts.

- a) In those contracts wherein the services/ jobs has been performed exclusively in the premises of the contractor, certificate to the effect is to be submitted by the contractor that services / job to be executed under the contract have been performed exclusively in his premises.

- b) In those contracts also wherein contractor has employed only their full time regular employees for execution of the contract, certificate to the effect is to be submitted by the contractor that for execution of the contract, no contractual labour has been employed and only full time regular employees of the contractor have been employed.

OR

- c) Fulfilment of conditions at (i) on EPF and (ii) on ESI mentioned below

(i) Information sought in above clause pertaining to only EPF shall not be required to be submitted in those contracts wherein the contractor has employed only those of his employees whose pay exceeds Rs. 6500/- per month thereby they are covered under the definition of %Excluded Employee. Certificate to the effect is to be submitted by the contractor that for execution of the contract, the monthly wages of all employees who have been employed, exceeds to Rs. 6500/- per month or they have been treated as %Excluded Employee+.

(ii) Information sought in above clause pertaining to only ESI shall not be required to be submitted in those contracts where in the contractor has employed only those of his employees whose pay exceeds Rs.21000/- per month as in terms of the current provisions of the ESI Act, 1948 an employee whose monthly pay exceeds Rs.21000/- is outside the purview of the ESI Act. Certificate to the effect is to be submitted by the contractor that for execution of the contract, the monthly wages of all employees who have been employed, exceeds Rs.21000/- per month. Further, ESI Act, 1948 is applicable only in areas where it has been made applicable by Gazette Notification in this regard (In the areas of ONGC operation, the ESI Act is currently applicable in all areas except the NE States. However, the Act is applicable in Guwahati. Applicability in new areas of operation is to be verified from the office of the ESI Corporation concerned.)

In case a contractor falling under the provisions of the Note mentioned above does not submit the required details on EPF and ESI payments, then in that case, the contractor shall be required to indemnify ONGC for any liabilities arising out of declarations made by him in future on violation or provisions of the EPF Act 1952 and ESI Act 1948.

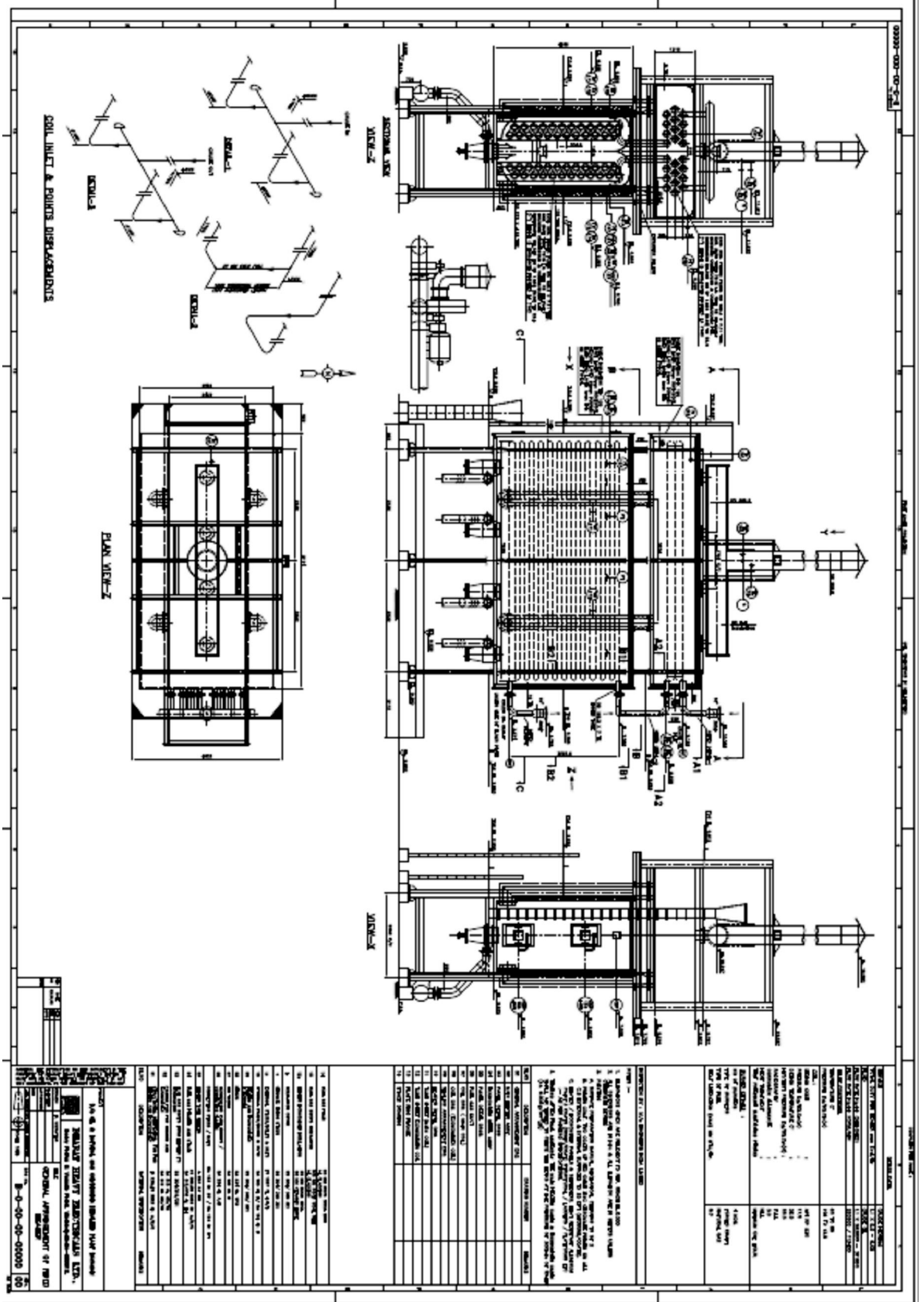

REVISIONS		DATE	
1	ISSUED FOR FABRICATION	23.05.2019	01
2	ISSUED FOR TESTING	23.05.2019	02
3	ISSUED FOR COMMISSIONING	23.05.2019	03

NO.	DESCRIPTION	DATE	BY	CHECKED
1	DESIGN	23.05.2019	[Signature]	[Signature]
2	CHECKED	23.05.2019	[Signature]	[Signature]
3	APPROVED	23.05.2019	[Signature]	[Signature]

NO.	DESCRIPTION	DATE	BY	CHECKED
1	DESIGN	23.05.2019	[Signature]	[Signature]
2	CHECKED	23.05.2019	[Signature]	[Signature]
3	APPROVED	23.05.2019	[Signature]	[Signature]

NO.	DESCRIPTION	DATE	BY	CHECKED
1	DESIGN	23.05.2019	[Signature]	[Signature]
2	CHECKED	23.05.2019	[Signature]	[Signature]
3	APPROVED	23.05.2019	[Signature]	[Signature]

FOR ALL INFORMATION AND REQUIREMENTS CONTACT: [Contact Information]

DESIGNED BY: [Name]

CHECKED BY: [Name]

APPROVED BY: [Name]

DATE: 23.05.2019

PROJECT NO: OPS/OS/WC/20119-20/117/016

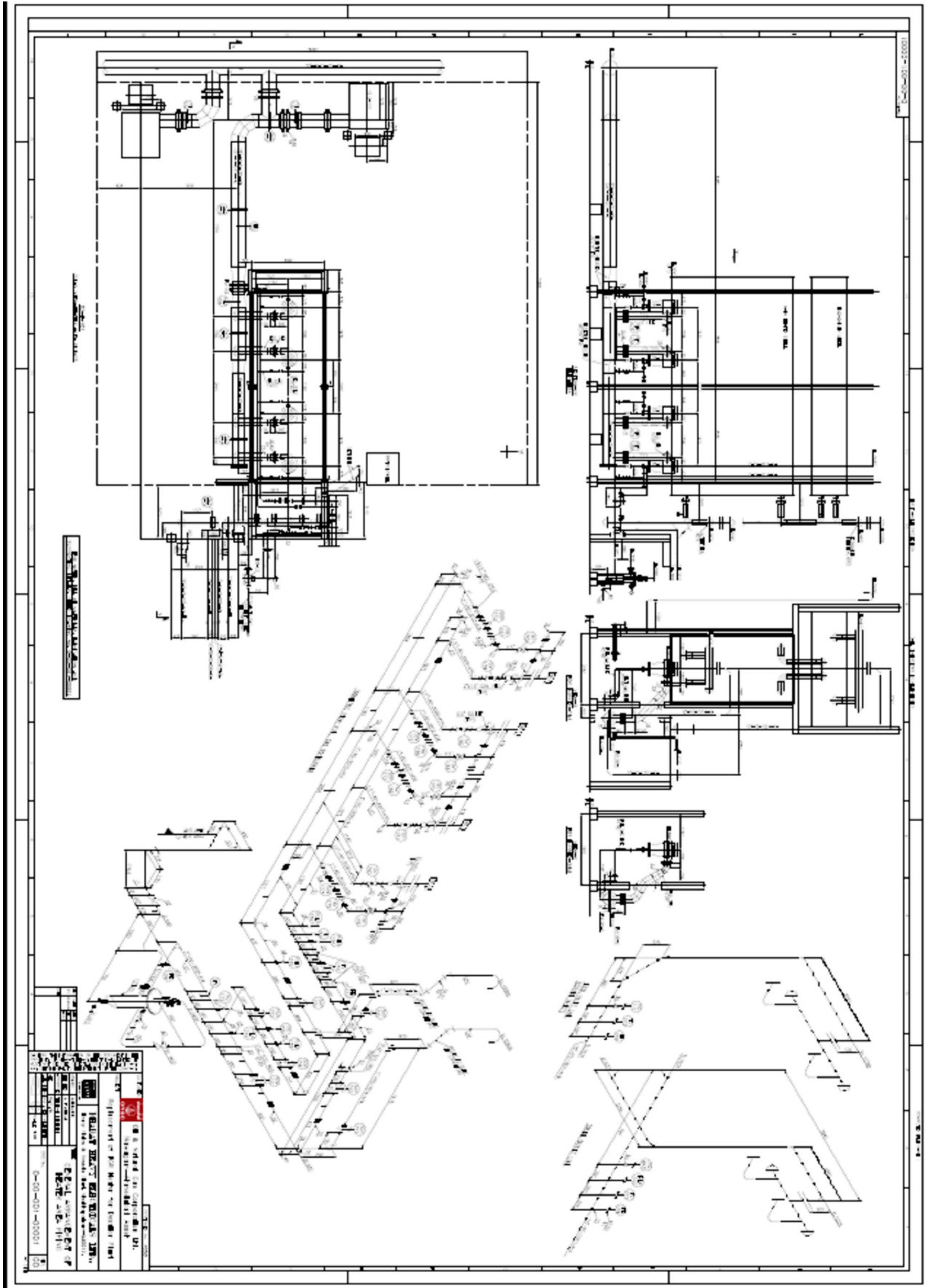





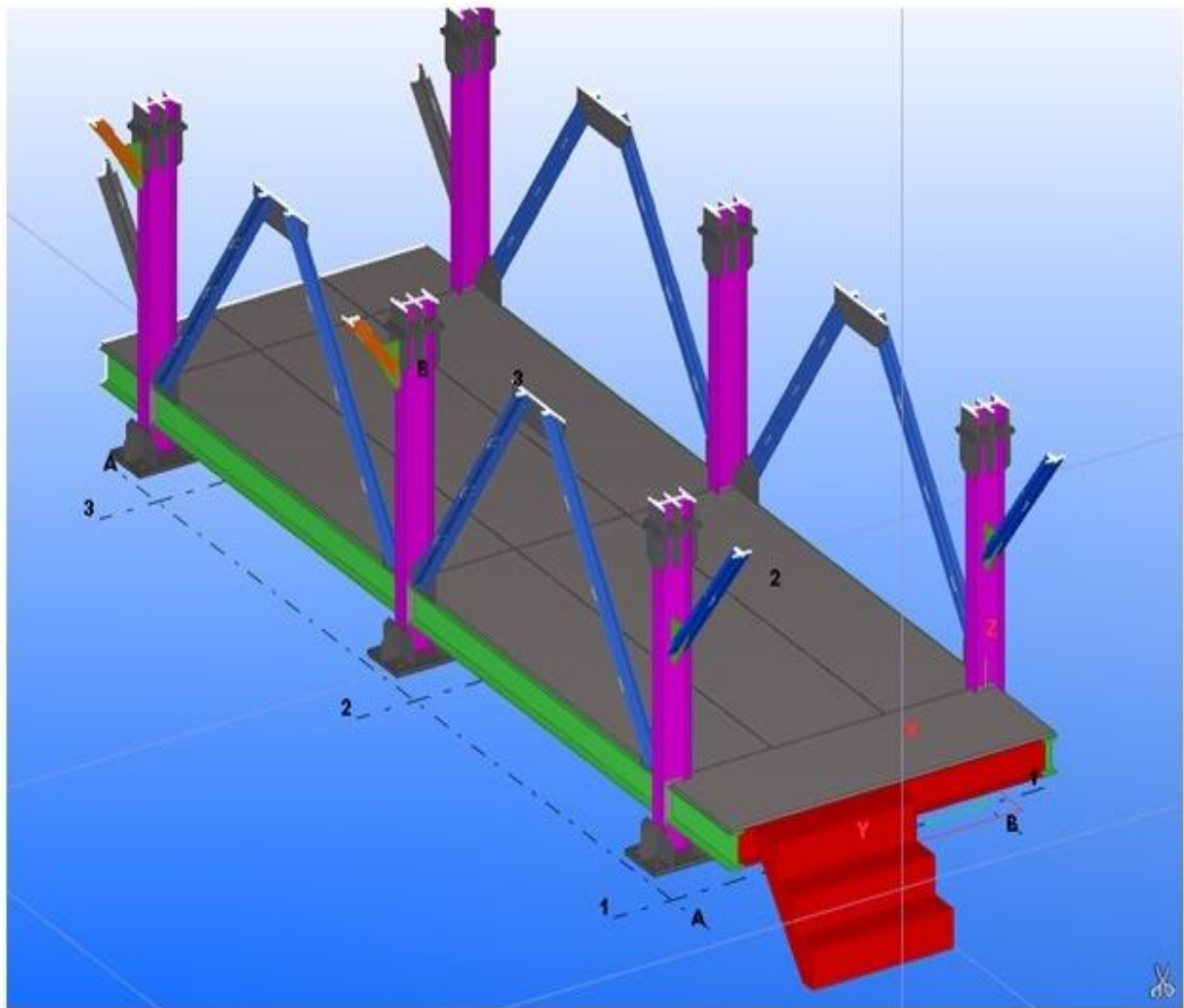

Modularization Philosophy	
1.	Bottom most portion of Heater Structure from base plate to bottom of Heater floor (i.e Main chamber floor) . despatched loose (weight included at SI.No. 12)-[3100 width x 10000 Lg x 2900 Ht]- (Refer Sketch -1)
2.	Main Shell with insulation and coils inserted with tube support castings bolted in position - <b>48 MT</b> [3100 width x 5000 Ht x 9000 Lg] (Refer Sketch -2)
3.	Economizer shell with insulation, Coils and Tube sheets in bolted condition- <b>33 MT</b> [4850 width x 3500 Ht x 9000 Lg] . (Refer Sketch -3)
4.	4 Nos. Inter connecting ducts (without external insulation) - <b>1.5 MT [Dia 273 x 5 Thk x 5000 Lg]</b>
5.	Flue gas collecting duct including Stack (without external insulation) - <b>2 MT</b> (Refer Sketch -4) - <b>[Dia 609.6 x 6 Thk x 16000 Lg]</b>
6.	Inlet & Outlet Headers with jump-over piping, crossover piping (without external insulation) despatched to site loose . weight included in SI.No.: 3
7.	Fuel Gas piping with valves (NOTE: complete Fuel Gas piping done at site with external insulation. Refer SOQ for quantity, size & length)- <b>3.5 MT without external insulation</b>
8.	1 No. FD Fan with Drive Motors . <b>4 MT</b>
9.	4 No. Fuel Gas Burners . <b>1.5 MT</b>
10.	4 No. Metallic Expansion Bellows . <b>500 Kg</b>
11.	1 No. Fuel Gas knockout Drum(without external insulation) . <b>400 Kg</b>
12.	All the platform structure, gratings, Stair tower will be fabricated and despatched to site loose . <b>15 MT</b>
13.	Utility piping as required. . <b>200 Kg</b>

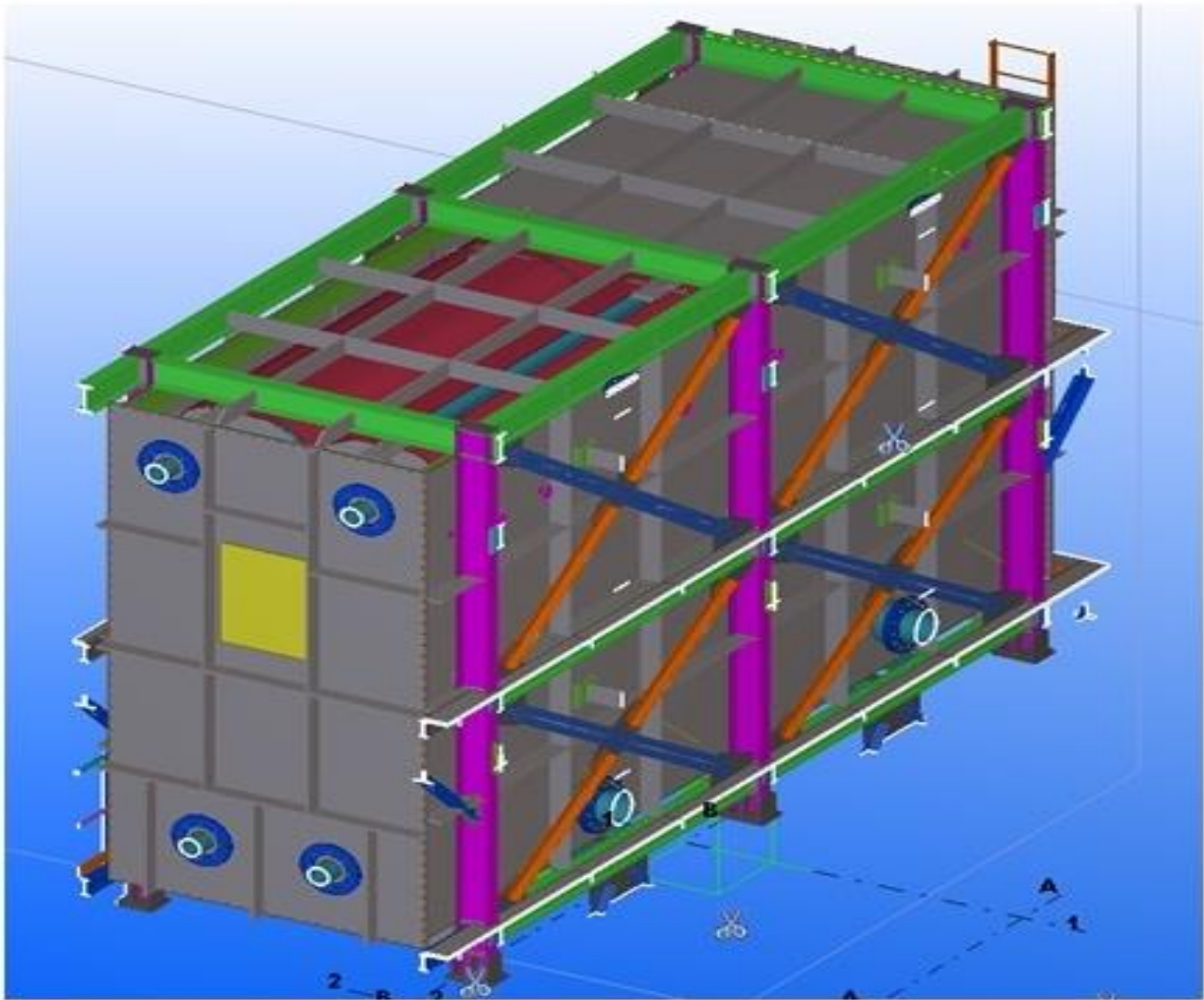

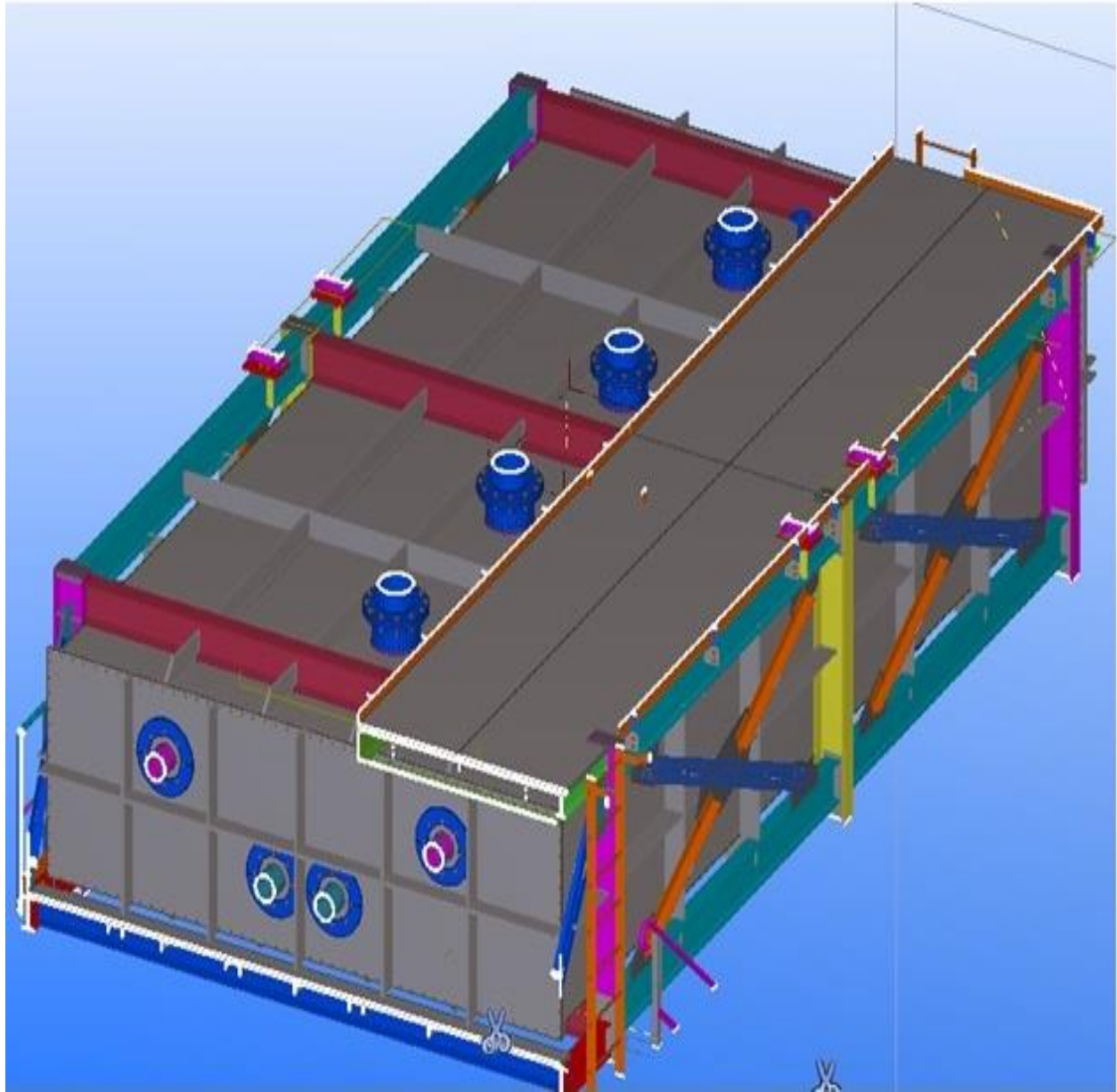

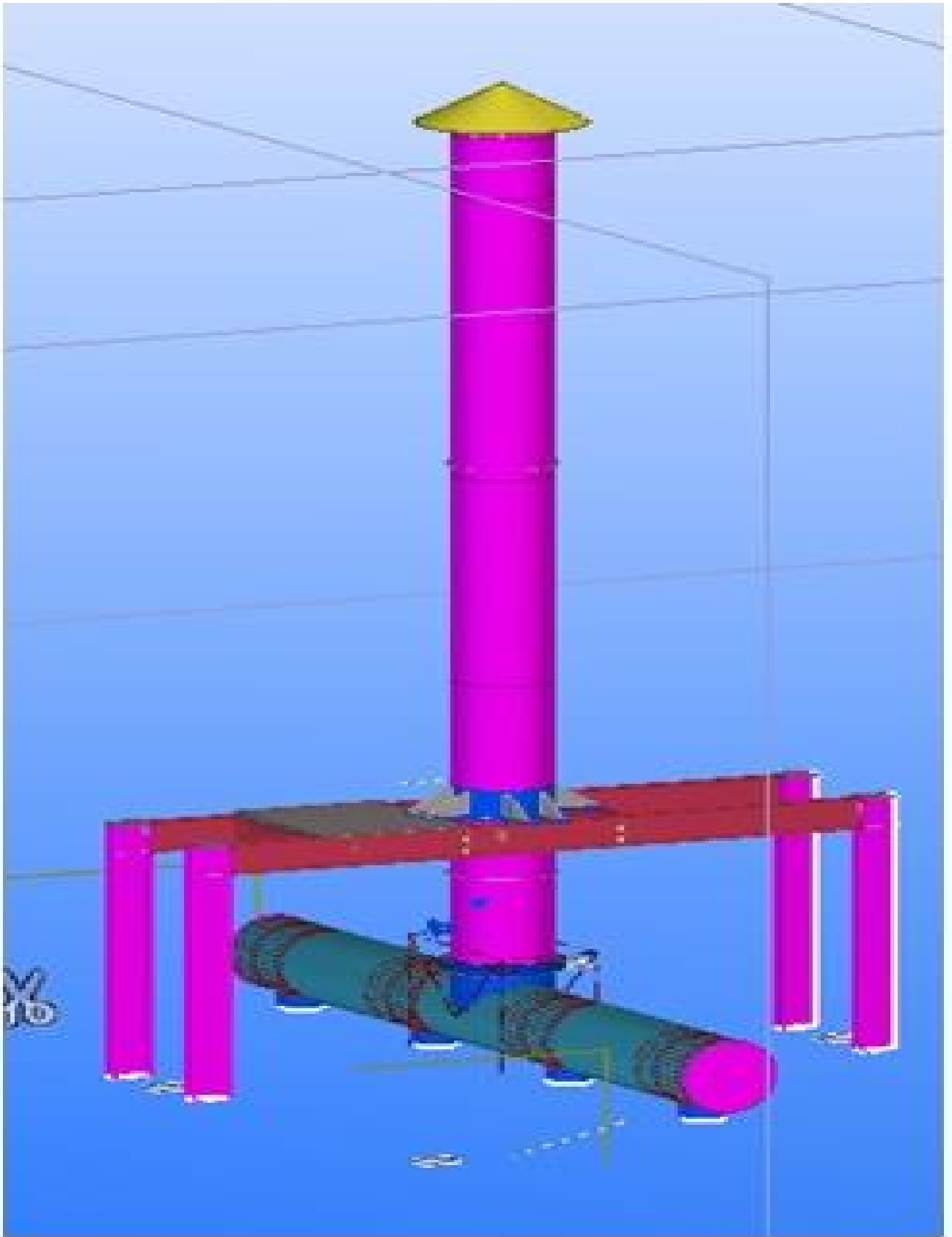



		<b>MANUFACTURER'S NAME &amp; ADDRESS</b> <b>BHEL-VISAKHAPATNAM</b>		<b>MANUFACTURING QUALITY PLAN</b>				PROJECT: ONGC NAVAGAM PACKAGE: Feed heater SO NO: 4051 Customer Reference: AMD/AMD-ASSET /SUPPORT /MM/2018/209918 dtd 02.01.19 (Contract No:9010029115)	
		ITEM: Feed heater system QP NO: CQP 2457 REV 00 Date: 13.02.2019 PAGE: 1 of 2		QUANTUM OF CHECK: 6 TYPE OF CHECK: 5 CLASS: 4 CHARACTERISTICS: 3		REFERENCE DOCUMENTS: 7 ACCEPTANCE NORMS: 8		FORMAT OF RECORD: 9 AGENCY: M C N	

SL No	COMPONENT & OPERATION	CHARACTERISTICS	CLASS	TYPE OF CHECK	QUANTUM OF CHECK	REFERENCE DOCUMENTS	ACCEPTANCE NORMS	FORMAT OF RECORD	AGENCY	REMARKS
<b>RAW MATERIALS &amp; BOUGHT OUT ITEMS</b>										
1.0	Other Materials as per respective material specification and BHEL Drawing									
1.1	Pipes & Tubes As applicable	Mechanical Chemical NDT as applicable	A	TC verification	100%	Material Specification as per Column 2, Internal TDC		√	QC	V
1.2	Flanges & Fittings As applicable	Mechanical Chemical NDT as applicable	A	TC verification	100%	Material Specification as per Column 2, Internal TDC		√	QC	V
1.3	Plates As applicable	Mechanical Chemical NDT as applicable	B	TC verification	100%	Material Specification as per Column 2, Internal TDC		-	QC	V
1.4	Check on sample basis									

<b>INPROCESS INSPECTION</b>						
2.0	ASME Sec IX as applicable			WPS	PQR	WQR
2.1	Welding Qualification	Procedure Qualification	B	WPS Review	100%	ASME Sec IX as applicable
2.2	Welder Qualification	Personnel Qualification	B	WQR Review	100%	AWS/IBR/IS (#)

Prepared By	Reviewed & Approved By	Approved By
V. Sunitha	V. Sampath kumar	Customer Signature & Stamp
V. Sunitha	V. Sampath kumar	Approved subject to correction against V.

Approved  
 21/2/19  
 (P. Gupta)  
 General Manager (P)  
 ONGC, Amritsar



**MANUFACTURER'S NAME & ADDRESS**  
**BHEL-VISAKHAPATNAM**

**MANUFACTURING QUALITY PLAN**

**ITEM:** Feed heater system  
 QP NO: C3P 2457 REV 00  
 Date: 13.02.2019  
 PAGE 2 of 2

**PROJECT:** ONGC NAVAGAM  
**PACKAGE:** Feed heater  
 SO NO: 4051  
 Customer Reference: AMD/AMD-ASSET /SUPPORT /MM/2018/209918 dtd 02.01.19  
 (Contract No:9010029115)

SL No	COMPONENT & OPERATION	CHARACTERISTICS	CLASS	TYPE OF CHECK	QUANTUM OF CHECK	REFERENCE DOCUMENTS	ACCEPTANCE NORMS	FORMAT OF RECORD			REMARKS		
								M	C	N			
1	2	3	4	5	6	7	8	9	D				
2.3	Edge preparation of pressure parts	Soundness	B	Visual	100%	Material specification				P	QC -		
2.4	Fit up inspection	Weld angle, mismatch, root gap	B	Visual & Dimension	100%	BHEL Drawing				P	QC -		
2.5	<b>NDT for Welds</b>												
2.5.A	Butt welds in piping	Soundness	B	RT	100%	API RP 530		RT Report	√	P	ND T	V*	*Verification of RT films
2.5.B	Root and final welds of all butt and fillet joints	Soundness	B	PT	100%	As per drawing		PT Report		P	QC	-	
2.6	PWHT	Temp Vs Time	B	Review	100%	Drawing & HT Cycle		HT Chart		P	QC	-	
2.7	Hydro test	Soundness	B	Visual	100%	BHEL Drawing		Hydro test report		P	QC	W	
3.0	<b>FINAL INSPECTION &amp; TESTING</b>												
3.1	Visual & Dimensional check	Visual & Dimensions	B	Visual Measurement	100%	BHEL Drawing		Inspection Report	√	P	QC	W	
3.2	Identification & Painting	Stenciling, Cleanliness & PMI	B	Verification, Visual	100%	BHEL Drawing & Approved paint scheme		Painting report		P	QC	-	
3.3	Preservation & packing	Packing	B	Visual & Verification	100%	BHEL Drawing		-		P	QC	-	
3.4	Data Folder	Documents	B	Verification	100%	As applicable		Data folder			QC		

*Ramesh*  
21/2/19

**परमेश गुप्ता**  
 मुख्य अभियंता (विद्युत)  
 ई. एण्ड पी. भूतल स्तर  
 ओ.एस.जी.सी, अहमदाबाद.



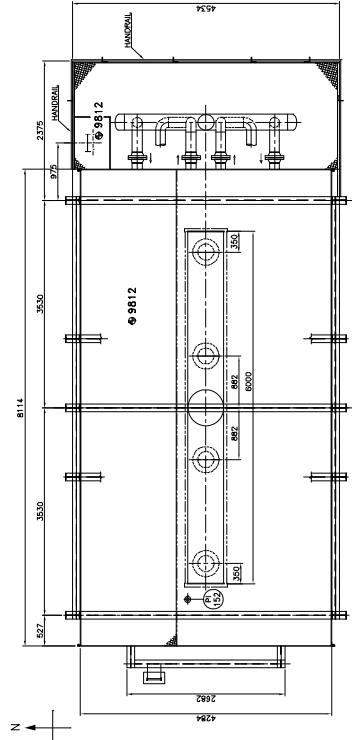

SECTION AA - PLAN AT 9812  
(FROM SHT. 1 OF 2)

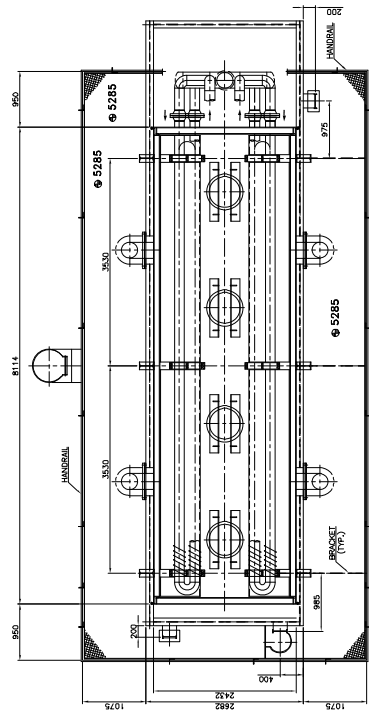

SECTION BB - PLAN AT 7519  
(FROM SHT. 1 OF 2)

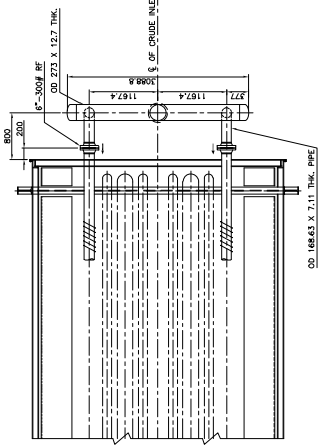

SECTION - A1A1  
(CRUDE INLET TO ECONOMISER COIL)

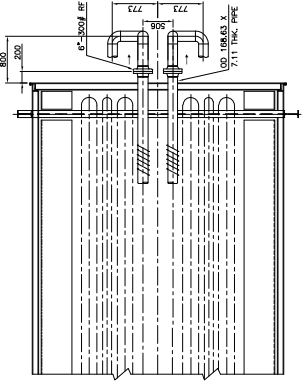

SECTION - A2A2  
(CRUDE OUTLET TO ECONOMISER COIL)

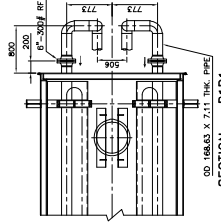

SECTION - B1B1  
(CRUDE INLET TO MAIN COIL FROM ECONOMISER COIL)

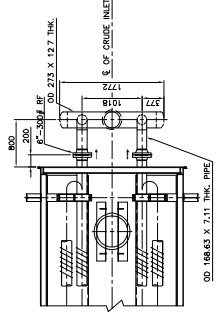

SECTION - B2B2  
(CRUDE OUTLET FROM MAIN COIL)

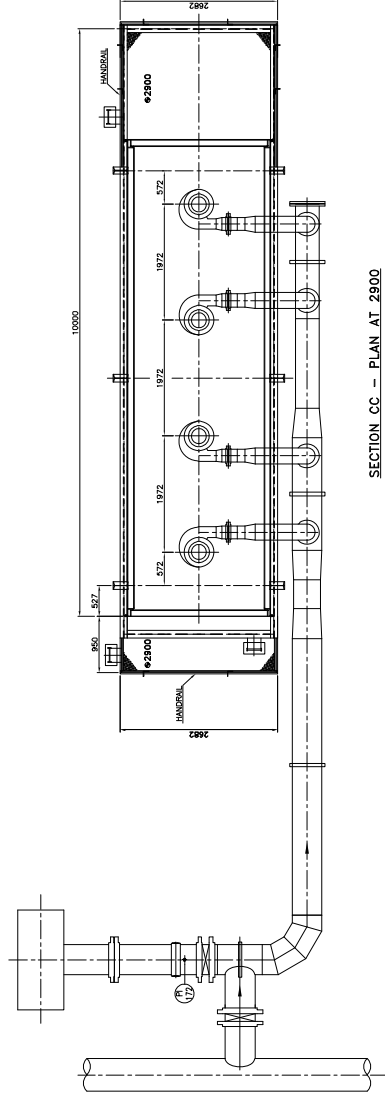

SECTION CC - PLAN AT 2900  
(FROM SHT. 1 OF 2)

PROJECT: M/O. OIL & NATURAL GAS COMMISSION DESALTER PLANT HANAGAM

**BHARAT HEAVY ELECTRICALS LTD.,**  
 Heavy Electric & Vessels Plant, Vessels Plant, Vessels Plant-330012.

DESIGNED BY: K. MANIYAN  
 DRAWN BY: K. MANIYAN  
 CHECKED BY: K. MANIYAN  
 SCALE: 1:50

REVISIONS:

NO.	DATE	DESCRIPTION

ALL DIMENSIONS ARE IN MILLIMETRES. DIM. IN. 1:50

GENERAL ARRANGEMENT OF FIRED HEATER

REV. 01 B-0-00-00-00000 00

COMPUTER FILE NAME :

(ALL DIMENSIONS IN MILLIMETERS)

FIRST ANGLE PROJECTION

Z6000-100-00-0

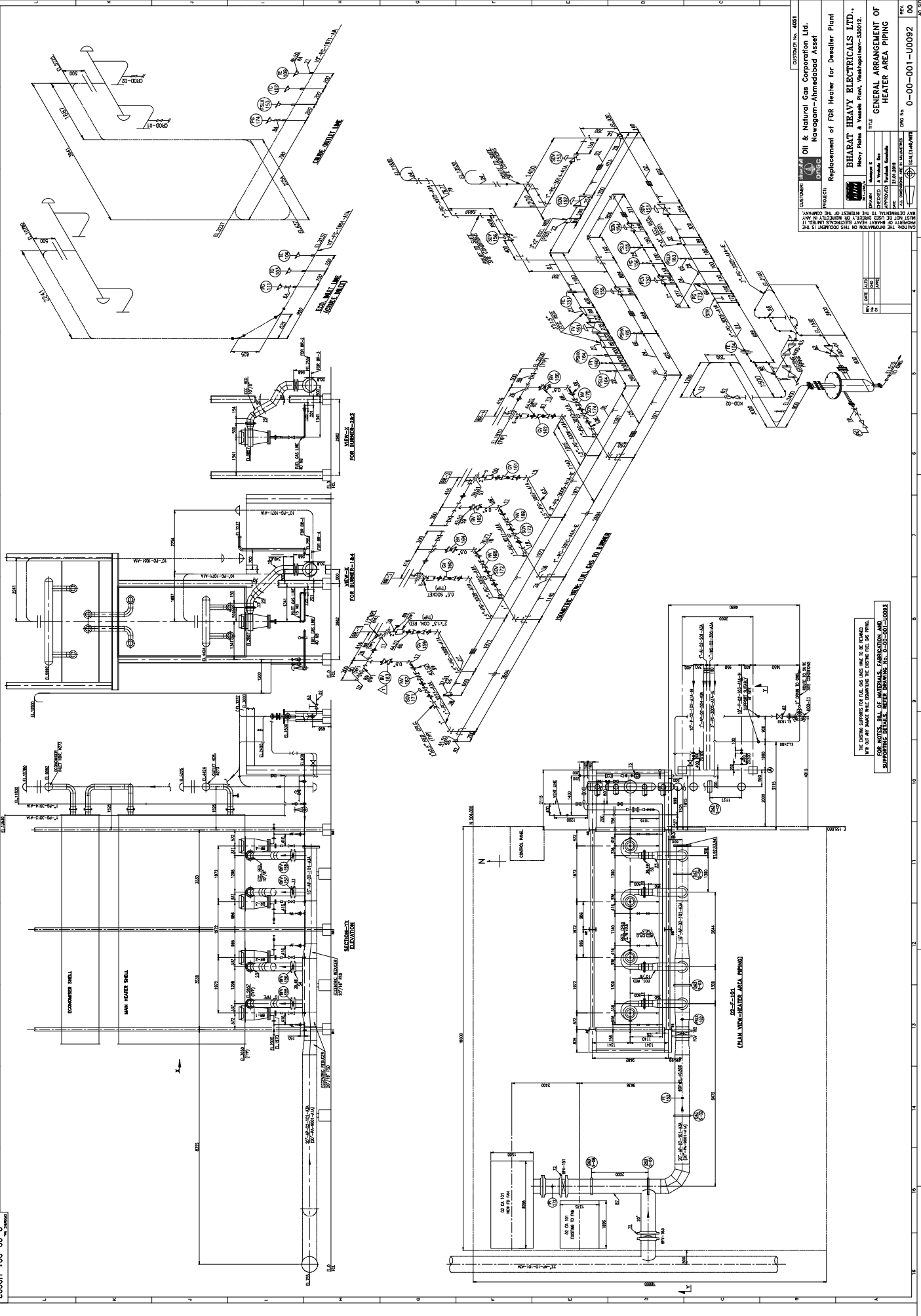

CUSTOMER NO.	4051
CUSTOMER	Oil & Natural Gas Corporation Ltd. Nowgong-Ahmedabad Asset
PROJECT	Replacement of HR Heater for Desalter Plant
DESIGNED BY	BHARAT HEAVY ELECTRICALS LTD. Heavy Fabric. & Erecting Plant, Vadodha-390012.
CHECKED BY	GENERAL ARRANGEMENT OF HEATER AREA PIPING
DATE	12.12.2018
SCALE	AS SHOWN
NO. OF SHEETS	01
TOTAL SHEETS	01
REV.	0-00-001-00092 00

THE EXISTING SUPPORTS FOR PIPE AND LINES HAVE TO BE RETAINED  
WITH OUT ANY CHANGE UNLESS INDICATED IN THE EXISTING PIPING AND  
FOR NOTES: BILL OF MATERIALS, FABRICATION AND  
SUPPORTING DETAILS, GENERAL ARRANGEMENT, SEE DRAWING SHEET

