



INVITATION TO TENDER

Ref : OS/19-20/7790/26/047

Date : 28.08.2019

Sub : **Fabrication of Deaerator Assembly & Loose Items for Auxiliary Boiler against S.O. 7790 at Vendor's works**

Dear Sir,

Sealed tenders are invited for the subject work in **two part bid** system from Vendors who are experienced in / capable of fabrication of similar jobs subject to the following eligibility criteria :

ELIGIBILITY CRITERIA

- (1) Bidders should have an experience of executing similar works (i.e. Fabrication of Pressure Vessels / equipments) for a minimum of one project as on 31st July/2019. Bidders shall have to enclose Work Orders and Work Completion Certificates in support of the same.
- (2) Average Annual Turnover of the bidders for the last 3 financial years should be Rs.5 Lakh. Bidders shall enclose IT Returns and other necessary documents in support of the same.
- (3) Bidders shall have to enclose the documents of Registration of Firm, Udyog Aadhar, PAN & GST.
- (4) The works executed in the name of individual / firm of the tenderer will only be considered for eligibility criteria.

1. LOCATION OF WORK SPOT :

The fabrication work is to be carried out at **Vendor's Works**.

2. VENDOR'S SCOPE OF WORK :

- a) Equipments to be fabricated are briefed below and the details are given in Annexure . II (B).

<u>S.O. No.</u>	<u>Project</u>	<u>Description of Item</u>	<u>Qty.</u>	<u>Total Weight</u>
7790	M/s BIFPCL, Maitree	Deaerator Assembly & Loose Items	1 Set	21 MT (approx.)

- b) Complete Fabrication of Deaerator Assembly along with Loose Items as per the GMS, Drawings, QAP, WPS & Specifications etc. listed in Annexure . II (A) & II (B) and it includes the following activities but not limited to the same :

- Fabrication involving operations like marking, cutting, rolling, machining, assembly, fit - up, welding & dressing, LPI, MPI, 100% Radiography, Air test for RF pads etc.
- Fabrication of Dished End blanks and Production Test Coupons which involves operations like Marking, Cutting, Fit-up, Welding, Radiography etc.
- Cold Forming of Dished ends including NDT (DP & UT) and normalizing through BHEL approved vendors as per Drawings, QAP & Specifications including necessary Certification.
- Rolling / Pressing of RF Pads.
- Fabrication of Nozzles & Saddles including Marking, Cutting, Rolling of plates, Welding etc.
- Fabrication and Fixing of CS / SS internals.
- Surface Cleaning by Grit / Shot Blasting, Painting as per the drawing / painting schedule.
- Quality Plan to be prepared by the vendor and submitted to BHEL . QC for approval.
- Hard Stamping and Letter painting for all Items in the prescribed format.

- c) Collection of free issue items from HPVP stores / shops, transportation to Vendor's works and Loading of finished equipments on to the trailer and welding of supports for transportation of the same to HPVP stores / shops / Logistics.
- d) Transportation of the equipment to HPVP Shops for SR and back to Vendor's Works after SR.
- e) Free issue items cleared by QC (Stores) to be collected within 3 days from the date of intimation without any failure. Any delay beyond the 3 days shall be considered for levying of L.D.
- f) Submission of economical Cutting plans for all the plate materials and sections issued by BHEL. Approval must be obtained from competent authority before taking up fabrication.

Wherever fabrication is done without proper approved cutting plans, any loss of materials arising due to the same will be recovered as per BHEL recovery rates.

- g) Fabrication of Spray Valves & Trays.
- h) Hydra Crane required for fabrication, unloading & loading at Vendor's works.
- i) Welding to be carried out by **ASME qualified welders** only. Qualification of welders, if required, shall be carried out by the vendor at their own cost.
- j) Qualified Engineers & Supervisors shall be deployed for proper co-ordination of the job.
- k) Any modification work due to revision of drawings during fabrication is to be carried out by the vendor without any extra cost. Though not mentioned specifically, any activity which is required for completion of the work is deemed to be included in the scope of work of vendor.

3. BHEL SCOPE : BHEL . HPVP shall provide the following as free issue :

- i) Drawings, BOMs, QAP & WPS and other applicable Standards & Specifications.
- ii) Raw materials like Plates (full / off-cuts), Pipes / Tubes, Round Bars, Structural items etc. in running meters and BOCs like fasteners, gaskets etc. as per Drawings / GMS from HPVP stores.
- iii) Paints as per requirement.
- iv) SR of the fabricated equipment.

4. INSPECTION :

Inspection shall be carried out by M/s. BHEL . Vizag / M/s Lloyds / Customer as per approved QAP. Contractor shall have to offer for Stage wise and Final inspection as per approved QAP and obtaining inspection clearance along with all necessary documentation.

5. DELIVERY :

Finished items along with inspection documents and all other certificates are to be handed over to HPVP Logistics as per the following schedule :

Within a maximum of **10 weeks** from the date of issue of First consignment of free issue materials or 4 weeks from the date of issue of Last consignment of materials whichever is later.

Note : For intermediate operations like SR, the time period from the date of handing over to the date of taking over will be excluded from the delivery period for the purpose of computation of LD.

6. PRICE :

The price shall be quoted as per the Schedule of Rates enclosed at Annexure . I for the detailed scope of work of each item. The prices shall be fixed & firm without any escalation during the entire period of contract and till completion of the work.

The quoted price shall be inclusive of all applicable taxes & duties except GST and Income tax will be deducted at applicable rates from RA & Final bills. GST shall be reimbursable to the vendor as detailed in Clause . 7 and as per Annexure . GST.

7. GOODS & SERVICES TAX (GST) :

Bidders shall make a note of the following points of GST before submission of their offer :

- Vendors registered under GST Act shall have to mention their GSTIN no. (15 Digits) in their Technical Bid. If any specific exemption is available, a declaration with due supporting documents need to be furnished for considering the offer.
- Semi-finished goods are to be delivered by the Vendors in BHEL, HPVP premises within a maximum period of one year from the date of issue of the material, failing which the whole transaction will be considered as Supply and Sale and GST is required to be paid along with interest (calculated @ SBI Base Rate + 6%) along with penalty, if any, from the date of Challan on the whole value of materials. Hence vendors shall have to ensure that materials issued to them are returned within 365 days.
- After fabrication, the vendors shall have to deliver the Semi-finished Goods by fulfilling the following formalities :

GST invoice should be raised by the vendors by paying GST on job work charges at applicable rates and by incorporating the HPVP GSTIN no. in the invoice for availing the reimbursement of GST from HPVP.

The vendor shall also have to enter in their GST Return -1 (GSTR-1) the details of invoice raised for payment of GST so as to enable HPVP to avail input credit.

8. REVERSE AUCTION :

BHEL reserves the right to opt for Reverse Auction at its discretion instead of opening the price bids submitted in sealed envelope and any information regarding the reverse auction shall be decided after technical evaluation and shall be intimated to the bidders at appropriate time. The bidders are requested to give their acceptance for participation in RA. Non-acceptance to participate in RA may result in non-consideration of their bids in case BHEL decides to go for RA.

In case BHEL decides to go for RA, only those bidders who give their acceptance will be allowed to participate in RA and these bidders shall have to necessarily submit ~~Online Sealed Bid~~ in the RA. Non-submission of ~~Online Sealed Bid~~ by the bidder will be considered as tampering of the tendering process and will invite action by BHEL as per extent guidelines in vogue.

9. Other Terms & Conditions shall be as per Annexure . III enclosed.

10. RISK PURCHASE :

In case the contractor fails to execute the work within the scheduled time or due to any other reasons, BHEL - HPVP reserves the right to get the same completed through some other party at the risk & cost of the contractor and any additional expenditure incurred due to the same shall be charged to the contractor.

11. VALIDITY OF OFFER :

The offer shall be valid for a period of **3 months** from the last date for tender submission.

12. GENERAL :

- The bidders shall study the Tender documents, Drawings, Quality Documents and all other relevant documents in detail for understanding the scope of work and the processes involved before submission of offers. One complete set of drawings shall be made available in the office of DGM (Outsourcing) and the same shall be referred during working hours. Drawings, QAP, WPS etc. shall be sent to vendor's e-mail address on their request.

For any clarifications required on this tender document, scope of work etc., the bidders shall depute their authorized representatives to BHEL, Visakhapatnam with prior intimation to get clarifications from concerned authorities between 09:00 AM and 04:00 PM.

- Bidders shall confirm their acceptance to all the terms & conditions of the tender enquiry. Any deviations to the tender terms & conditions are not acceptable and BHEL reserves the right to reject such offers without further correspondence
- BHEL reserves the right to modify or cancel the tender enquiry at any stage without assigning any reasons thereof.

13. The following documents shall form part of the tender enquiry :

- | | |
|---|---------------------|
| i) Schedule of Rates | : Annexure – I |
| ii) List of Applicable Drawings & Documents | : Annexure – II (A) |
| (Drawings shall be sent by e-mail to vendor's registered e-mail address on request) | |
| iii) Details of De-aerators to be fabricated | : Annexure – II (B) |
| iv) General Terms & Conditions | : Annexure – III |
| v) Acceptance to tender terms & conditions | : Annexure – IV |
| vi) General Terms & Conditions of Reverse Auction | : Annexure – V |
| vii) GST Compliance for Indigenous Suppliers | : Annexure – GST |

14. TENDER SUBMISSION :

Techno-Commercial bids shall be submitted along with the **tender document duly signed & stamped by the bidder on all pages**. Techno-Commercial Bid and Price bid shall be placed in two separate envelopes and both shall be kept in another big envelope.

Tenders completed in all respects shall be **dropped / sent by post** to the following address before **14.00 hrs. on 12.09.2019** duly super scribing on the envelopes with the Subject, Tender Ref. No. and Technical / Price Bid etc.:

Outsourcing Tender Box,
 Reception Counter, ADM Building,
 Heavy Plates & Vessels Plant,
 BHEL, Visakhapatnam
 PIN – 530 012 (A.P.)

TENDERS RECEIVED AFTER THE DUE DATE & TIME ARE NOT ACCEPTABLE.

Note : Offers sent in any other form will be treated as invalid and will be summarily rejected.

15. OPENING OF TENDERS :

Techno-commercial Bids will be opened on **12.09.2019 at 14.00 Hrs.** at Customer Cell, Admn. Building, BHEL - HPVP, Visakhapatnam. The price bid of the techno-commercially qualified bidders will be opened in presence of representatives of the bidders and the date & time of opening of price bids will be intimated later. The bidders may depute their representatives at the time of opening.

In case of opting for Reverse Auction, intimation shall be given to the qualified bidders in advance at appropriate time.

for Bharat Heavy Electricals Limited,

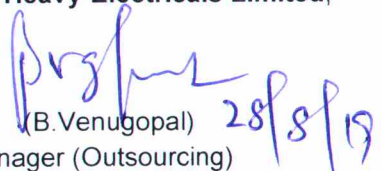
 (B. Venugopal) 28/8/19
 Manager (Outsourcing)

Schedule of Rates

Ref : OS/19-20/7790/26/047

Date : 28.08.2019

Sub : Fabrication of Deaerator Assembly & Loose Items for Auxiliary Boiler against S.O. 7790 at Vendor's works

Sl. No.	S.O. No.	Description of Work	Unit	Total Qty.	Rate per MT (in ₹)	Total Amount (in ₹)
1	7790	Complete Fabrication of Deaerator Assembly and Loose Items including Forming of Dished ends as per the Drawings, Specifications, QAP & WPS with free issue raw materials & BOCs including Collection of FIMs from HPVP stores / shops, transportation to Vendor's Works, transportation of equipment from Vendor's Works to Shops for SR and back to Vendor's Works, Handing over of the finished equipments to HPVP Logistics dept. and loading of equipments onto the trailers & welding of supports for transportation, etc. complete in all respects as per the detailed scope of work mentioned in the tender document. 1 Set @ 21.00 MT	MT	21		
		Total				
Total Amount in Words :						

Notes :

- 1) L1 shall be evaluated on total quoted value.
- 2) The weights indicated above are approximate and may increase or decrease slightly subject to revision or addition or deletion of drawings. However, payment shall be made for the actual weight as per the applicable drawings / BOM.
- 3) The prices shall be fixed & firm without any escalation during the entire period of contract and till completion of the work.
- 4) The quoted price shall be inclusive of all applicable taxes & duties except GST and Income tax shall be deducted at applicable rates from the vendor's bills. GST shall be reimbursable to the vendor as detailed in Clause – 7 and as per annexure-GST.
- 5) Tenderer should quote the amount in figures & words. It may be noted that corrections, overwriting etc. are not allowed. If there is a discrepancy between amount in figures & words, the amount in words shall prevail unless the amount expressed in words is related to an arithmetic error, in which case the amount in figures shall prevail. If there is an error in the total corresponding to the addition or subtraction of sub-totals, the sub-totals shall prevail and total shall be corrected accordingly.

In case of mismatch between rate and amount in figures, rate in figures shall be taken into consideration for further evaluation and processing.
- 6) BHEL reserves the right to go for Reverse auction as per the applicable guidelines instead of opening price bids.

Signature of the Bidder with stamp

LIST OF APPLICABLE DRAWINGS & DOCUMENTS

Sl. No.	S.O. No.	Description	Drawing / Doc. Ref. No.	Rev. No.
1	7790	DEAERATOR MAIN ASSEMBLY	1-81-026-U8027	00
2		FEED WATER STORAGE TANK (OD 3000)	1-81-026-U8026	01
3		VENT AND SPARY ASSEMBLY OF DEAERATOR	1-81-026-U8025	00
4		DEAERATOR ASSY. 90T/HR	1-81-026-U8024	00
5		DEAEARATOR TRAY ASSEMBLY	3-81-026-U8039	00
6		DEAEARATOR TRAY	3-81-026-U8040	00
7		CONDENSING CHAMBER ASSEMBLY	2-81-026-U8005	00
8		MAN HOLE ASSEMBLY	3-81-026-U8041	00
9		SPRAY NOZZLE ASSSEMBLY	3-81-026-U8028	00
10		DEFLECTING GUIDE ASSEMBLY	3-81-026-U8029	00
11		TRAY SUPPORT	3-81-026-U8030	00
12		SLIDING SADDLE	3-81-026-U8038	00
13		FIXED SADDLE	3-81-026-U8031	00
14		SUPPORT ASSEMBLY	3-81-026-U8035	00
15		SUPPORT TUBE (D60.3X3.91)	3-81-026-U8044	00
16		PIPE WITH END CLOSURE	3-81-026-U8033	00
17		STAND PIPE (FOR LEVEL TRANSMITTER)	3-81-026-U8034	00
18		STAND PIPE ASSEMBLY	1-81-026-U8027	00
19		STAND PIPE (FOR LEVEL GAUGE)	3-81-026-U8036	00
20		NAME PLATE ARRANGEMENT	3-81-026-U8037	00
21		TEMP. STUB RC1", M33X2	4-81-026-U8060	00
22		FLAT END CLOSURE DIA 219.1	4-81-026-U8061	00
23		PLUG R1", M33X2	4-81-026-U8062	00
24		DISHED END-OD3000, 16THK	4-81-026-U8063	00
25		SW STUB, NB15, CL3000	4-81-026-U8064	00
26		SW STUB NB 25 - CL 3000	4-81-026-U8065	00
27		SW STUB NB 40 - CL 3000	4-81-026-U8066	00
28		SW STUB NB 50 - CL 3000	4-81-026-U8067	00
29		SOW FLANGE NB600, PL50,DIA780/614	4-81-026-U8068	00
30		BLANK FLANGE NB.600, 35THK, DIA780	4-81-026-U8069	00
31		HANDLE DIA 16	3-81-026-U8041	00
32		ORIFICE PLATE - 6 THK	2-81-026-U8005	00
33		NOZZLE HOLDER - 10 THK	1-81-026-U8025	00
34		SPRING RETAINING PLATE 40	3-81-026-U8044	00

LIST OF APPLICABLE DRAWINGS & DOCUMENTS

SI. No.	S.O. No.	Description	Drawing / Doc. Ref. No.	Rev. No.	
35	7790	STEM 12	3-81-026-U8044	00	
36		GUIDE PLATE 10 THK	3-81-026-U8044	00	
37		NOZZLE PLUG 63	3-81-026-U8044	00	
38		NAME PLATE 130 x 300	4-81-026-U8046	00	
39		NOZZLE BASE PLATE 10 THK	3-81-026-U8028	00	
40		INNER CONE PLATE 5 THK	3-81-026-U8029	00	
41		OUTER CONE PLATE 5 THK	3-81-026-U8029	00	
42		STIFFNER PLATE 5 THK	3-81-026-U8029	00	
43		INNER RING - 5 THK PLATE	3-81-026-U8039	00	
44		OUTER SEGMENT - 5 THK PLATE	3-81-026-U8039	00	
45		U SEGMENT - 5 THK PLATE	3-81-026-U8039	00	
46		TOP PLATE - 5 THK PLATE	3-81-026-U8030	00	
47		BOTTOM PLATE - 5 THK PLATE	3-81-026-U8030	00	
48		TORI SPH. DÉND - OD 1500	4-81-026-U8076	00	
49		SOW FLAGE - NB 150 CLASS 150	4-81-026-U8078	00	
50		LINK PLATE	3-81-026-U8043	00	
51		HINGE SUPPORT PLATE	3-81-026-U8043	00	
52		RIDGE PLATE	3-81-026-U8043	00	
53		GUIDE PIN, DIA 50.0 MM	4-81-026-U8083	00	
54		7790	QUALITY PLAN	To be developed by the vendor	
55		Std.	WELDING PROCEDURE SPECIFICATION	M.1.1.02	00
56				M.1.1.28	00
57				M.1.1.37	00
58	M.1.4.27			00	
59	M.4.4.17			00	
60	M.4.8.61			00	
61	M.5A.5A.05			00	
62	M.8.8.43			00	
63	M.S.1.1.01			01	
64	M.S.1.1.09			00	
65	T.1.1.01			00	
66	T.1.1.14			00	
67	T.M.1.1.02			00	
68	T.M.1.1.31			00	

Note : The drawings & documents mentioned above are tentative only and the job is to be executed as per the Engg. drawings & documents issued at the time of execution.

Ref : OS/19-20/7790/26/047

Date : 28.08.2019

DETAILS OF DEAERATORS TO BE FABRICATED

DU No.	Description of Item	S.O. 7790		
		Item Weight (Kg.)	Qty.	Total Wt. (Kg.)
1	Feed Water Storage Tank - Dia 3000 mm	16308.35	1	16308.35
2	Deaerator Assembly 90 T / HR	1947.40	1	1947.40
3	Fixed and Sliding Saddles	2445.42	1	2445.42
4	Stand Pipe Assembly	143.48	1	143.48
5	Round Dia 16 - SA 105	9.47	10	94.70
6	Plate size in mm - 10 x 400 x 400	12.56	1	12.56
	Total			20951.9

Note : Quantities and weights mentioned above are tentative and may slightly vary as per the Engg. drawings & documents issued at the time of execution.

GENERAL TERMS & CONDITIONS**1. TECHNICAL DELIVERY CONDITIONS :**

The work should conform to the technical data given in our drawings, GMS, Shipping List Specifications, QAP, WPS etc.

2. PARTY'S SCOPE :

The scope of the party shall be as follows: -

- a) All welding equipments, baking oven, tools, jigs and fixtures, measuring instruments duly calibrated, handling facilities, testing facilities etc.
- b) All materials other than those mentioned under "Free Issue Materials", which are required for completion of the work.
- c) All consumables such as electrodes, gases, grinding wheels etc.

Note : Electrodes of specification mentioned in the drawings / WPS and of BHEL approved brands only shall be used.

3. REVISION OF DRAWINGS :

There may be minor changes in the drawings during execution. In such a case, party should accommodate the same without any extra claim.

4. WELDING QUALIFICATION : Qualification of required number of Welders is party's responsibility at their cost.**5. X-RAY :**

All welding shall be of X-ray quality where specified on drawings. Inspection would specify the quantum of X-ray based on drawings / code requirement. Party should strictly follow the WPS and QAP supplied by BHEL during welding. Getting the welds radiographed and getting them cleared by inspection is the responsibility of the party.

6. RECTIFICATIONS / REJECTIONS :

Any rectification due to defective work, if required, shall be done by the party free of charge with a suitable technology approved before hand by BHEL in writing. The cost of material, if any used for rectification work / rejection work, will be estimated by BHEL and the same shall be debited to party's account. In case any rectification / rework is to be carried out due to defective material supplied by BHEL, the replacement material and consumables will be supplied by BHEL free of Cost.

7. SECURITY DEPOSIT :

Vendors shall have to submit a Bank Guarantee for **10%** of the order value in case of **HPVP ADM site** or **25%** of the material cost in case of Vendor works towards Security Deposit and safe custody of materials within one week from the date of issue of Order. The BG shall be valid for the contract period with a claim period of 3 months. This Bank Guarantee shall be released to the contractor after completion of work and on acceptance of the same by BHEL / Owner and on submission of Performance BG for 10 % of the order value covering for the defects liability period. If PBG is not submitted, 10% of the order value shall be deducted towards PBG from final bill.

8. RAW MATERIALS ISSUE :

Raw materials shall be issued with appropriate processing allowance and invisible wastage over the theoretical requirement of raw materials (**Plates, Sheets, Sections and Pipes**).

9. TRANSFER / RETURN OF LEFT OVER MATERIALS :

Party should maintain proper records for receipt & use of all free issue materials. The left over materials & scrap as per the material accounting statement shall be returned to HPVP stores along with finished job. Material Transfer Vouchers (MTV) from one order to another or from one vendor to another and Material Return Vouchers should be submitted immediately after transfer / return. The material reconciliation statement shall be submitted by the contractor after verification and certification by BHEL along with the final bill **within 30 days from the date of completion of work**. Otherwise, recovery for the balance materials shall be made from any of their pending bills without further intimation.

10. MATERIAL RECONCILIATION :

Orders issued to the vendors have to be completed in all respects including Material Accounting within a maximum of **180 days** from the **date of issue of the first material** from BHEL - HPVP stores. This is a statutory requirement under Central Excise Rules and must be strictly complied with.

Maximum of 0.5 % on the requirement of materials (**Plates, Sections and Pipes**) is admitted towards **process allowance and invisible wastage**.

Scrap quantity is permissible up to a **maximum of 1% on Structural (Beams, Channels, Angles, Rods, Pipes etc.), 2% on Sheets, 3% for Plates** on the theoretical requirement of materials.

If wastage and scrap is beyond the above limits, it should be fully justified with cutting diagrams etc. which are to be approved in advance by BHEL. **Otherwise, the cost of raw materials beyond approved limits will be recovered from the contractor as per BHEL recovery rates including applicable taxes & duties.**

Material reconciliation including return of balance materials, off-cuts is to be completed within 20 days from the date of completion of the order. The material reconciliation statement shall be submitted by the contractor after verification and certification by BHEL-HPVP along with the final bill **within 30 days from the date of completion of work**. Otherwise, recovery for the balance materials shall be made from any of their pending bills without further intimation,

Repeated occurrence of inordinate delays in returning and settling the material accounting will entail BHEL the right to terminate the contract forthwith or impose a temporary suspension on further loading at the discretion of BHEL.

11. SCRAP & OFFCUT NORMS :

SI. No.	Description	Scrap Size (in mm)	Off-Cut (in MM)
1.	CS/AS Sheets & Plates	Below 500 × 250	500 × 250 & above
2.	Rolled sections Rod, angles etc. (other than -tubes, pipes)	Below 1000	1000 & above
3.	Tubes & Pipes	Below 500	500 & above
4.	Universal column	Below 1000	1000 & Above
5.	SS Sheets & Plates	Below 500 × 250	500 × 250 & above
6.	SS Structural, Rods, Tubes, Pipes	Below 250	250 & above
7.	Non – ferrous: sheets & plates, rods & tubes	Below 500 × 250 (S & PL), Below 250 (Rods & Tubes)	500 × 250 & above, 250 & above
8.	Big size Scrap	(2500 & above) × (150 to 249)	-

12. INSPECTION :

Party shall contact our Quality Control Dept. for stages of inspection before commencement of job and should strictly follow the stages of inspection as per QAP.

13. WORKMANSHIP GUARANTEE :

The vendors should give workmanship guarantee for fabricated items for a period of 18 months from the date of last delivery of the order. Any defects due to incomplete work, faulty workmanship found in the fabricated items after delivery during the defects liability period shall be rectified / replaced by the vendor free of cost. Otherwise, the expenditure incurred towards the same will be recovered from the pending bills of vendors.

14. WORK PROGRESS :

The fabricator shall furnish a weekly report on the progress of work along with the status of availability of free issue materials and requirement of further materials, if any.

Outsourcing dept. personnel will visit vendor's works from time to time to assess and review the work progress. Free access shall be provided to BHEL or its inspection agency at all reasonable times of the day / night.

In case the progress is not satisfactory or supplies are delayed abnormally beyond the contractual delivery date, BHEL-HPVP, Visakhapatnam reserves the right to cancel the order in part or full or get the balance job in as is where is condition completed elsewhere by another agency at the risk and cost of Fabricator. The value of the work carried out by the party will be assessed by BHEL and the same shall be final. No compensation will be given to the fabricator in case of cancellation of order or diversion of balance job even if the jobs have been processed partly.

15. DELIVERY :

Finished items should be handed over to the Logistics dept. on party's delivery challans along with Job completion certificate / Final Inspection Report from inspection agency / HPVP-QC department.

16. PENALTY :

If delivery exceeds the stipulated delivery schedule, penalty 1/2 % of the total value of order per week or part there of subject to a maximum of 10% on the total value of the order will be levied. However, time taken for the following will not be considered as delay on the part of the Sub-Contractor.

- 1) Intermediate operations, if any, carried out by BHEL.
- 2) Waiting time for BHEL / Third party Inspection beyond a normal time of 3 days.

17. PAYMENT TERMS :

100% payment will be made against delivery of the finished items duly inspected & cleared by Inspection authority along with all inspection documents to Logistics Dept. Payment shall be made within **45 days** from the date of submission of RA Bill.

Only one bill will be admitted for orders with value less than Rs. 5 lakhs and a maximum of two bills are allowed for orders of value more than Rs. 5 lakhs. In such cases, the first bill value shall be restricted to a maximum of 50 % of the order value and a minimum of 50% of the total DUs of the order.

Vendors shall have to submit the bills in the formats specified by HPVP-Outsourcing and the bills submitted in the specified format along with necessary supporting documents are only admitted for processing. The following documents shall be submitted along with the Final Bill: -

1. No Claim Certificate from the contractor
2. No Dues Certificate from BHEL
3. Work Completion Certificate from BHEL
4. Material Reconciliation Statement submitted by the Contractor and certified by concerned authority of BHEL (if applicable)
5. Workmanship Guarantee certificate from the contractor

18. SECRECY :

All the documents of BHEL inclusive of Drawings, GMS and Standards made available to the fabricator should be kept in strict confidence and under no circumstance be made available to others or allow others to make use of them. Such documents shall be returned to BHEL on demand after completion of the job. This secrecy clause is binding on the employees of the fabricators also. Violation of the same may lead to suspension of business with the vendor and necessary legal action.

19. SUB-LETTING :

In general, sub-letting of jobs will not be permitted. But in special circumstances, this may be allowed. In such case, the party should obtain written approval from BHEL-HPVP, Visakhapatnam before sub-letting.

20. FACTORY RULES AND REGULATIONS :

Party shall abide by all the rules and statutory regulations in force from time to time as per factories act. It shall be party's responsibility to ensure the safety of their workmen and fulfilling the ESI, PF and other relevant statutory regulations.

21. SAFETY :

- a) Contractor shall adhere to safe construction practices, guard against hazardous & unsafe working conditions and shall comply with the safety rules of BHEL and local authorities. He shall maintain First Aid facilities for all his employees and labour. Contractor's responsibility includes supply of welder kit, all safety items such as safety belts, white and colour glasses, goggles, safety helmets, safety shoes etc.
- b) *Contractor and his employees shall follow all fire & safety, security regulations of BHEL.*

22. HOUSE KEEPING :

During execution of work, the contractor at all times keep the working place and storage area clean and free from accumulation of waste materials, rubbish etc.,

23. ACCIDENT / DAMAGE / CONDUCT ETC. :

Contractor will be held responsible for any disorderly conduct / misconduct, indiscipline, theft, smoking etc., on the part of his men. He will ensure summary eviction of such men from his premises failing which BHEL would remove them from the factory on his responsibility. Any damage to and or loss of equipment, machinery, building etc., to BHEL or BHEL employees, visitors or other contractors resulting from his own or any of his men's negligence shall be liable to be made good by him. Contractor shall be solely responsible for any accident in which you or your men or your equipment may be involved during the execution of contract on account of any reason what so ever.

24. TERMINATION OF CONTRACT :

In the event of any failure on the part of the contractor, BHEL reserves the right to terminate the contract by giving a notice of 2 weeks for any of the following lapses and contractual violations: -

- a) Failure to make labour payments in time as per the rules
- b) Failure to progress the job according to the agreed schedule
- c) Failure to mobilize adequate man power, tools & tackles and consumables in time
- d) Failure to adhere to Quality Standards of BHEL
- e) Refused to co-operate with other agencies working in the same area
- f) Failure to resolve labour disputes like strikes etc., within 7 days of occurrence
- g) Failure to comply with statutory regulations applicable at BHEL

BHEL shall also be free to intervene and take necessary remedial measures. All costs incurred with interest and overheads shall be recovered from contractor by such foreclosing or off-loading any part of the contract work.

25. DISPUTES :

Head of BHEL- HPVP Unit will be the final authority for any disputes arising out of this contract. The disputes / arbitration / settlement of contractual or legal issues shall be under the Jurisdiction of Visakhapatnam Court.

- 26.** For this procurement, Public Procurement (Preference to Make in India), Order 2017 dated 15.06.2017 & 28.05.2018 and subsequent Orders issued by the respective Nodal Ministry shall be applicable even if issued after issue of this NIT but before finalization of Contract / PO / WO against this NIT.

In the event of any Nodal Ministry prescribing higher or lower percentage of purchase preference and / or local content in respect of this procurement, same shall be applicable.

Signature of Bidder with Stamp

Acceptance to Tender Terms & Conditions

I / We hereby confirm that the Tender documents, Drawings, Quality documents etc. have been studied in detail and we have fully understood the scope of work.

I / We accept to all the Terms and Conditions of the Tender Enquiry and the prices quoted are in accordance with the same.

I / We give our acceptance to participate in reverse auction in case BHEL decides to opt for reverse auction for this tender.

Tender documents duly signed on all the pages by the Owner / authorized representative of the bidder are attached herewith.

Signature of the Bidder with Stamp

GENERAL TERMS AND CONDITIONS OF RA (REVERSE AUCTION)

BHEL reserves the right to go for Reverse Auction (RA) (Guidelines as available on www.bhel.com) instead of opening the sealed envelope price bid, submitted by the bidder. This will be decided after techno-commercial evaluation. Bidders have to give their acceptance with the offer for participation in RA. Non-acceptance to participate in RA may result in non-consideration of their bids, in case BHEL decides to go for RA.

Those bidders who have given their acceptance to participate in Reverse Auction will have to necessarily submit ~~Process~~ compliance form (to the designated service provider) as well as ~~Online~~ sealed bid in the Reverse Auction. Non-submission of ~~Process~~ compliance form or ~~Online~~ sealed bid by the agreed bidder(s) will be considered as tampering of the tender process and will invite action by BHEL as per extant guidelines for suspension of the business dealings with suppliers/ contractors (as available on www.bhel.com).

The bidders have to necessarily submit online sealed bid less than or equal to their envelope sealed price bid already submitted to BHEL along with the offer. **The envelope sealed price bid of successful L1 bidder in RA, if conducted, shall also be opened after RA and the order will be placed on lower of the two bids (RA closing price & envelope sealed price) thus obtained. The bidder having submitted this offer specifically agrees to this condition and undertakes to execute the contract on thus awarded rates.**

If it is found that L1 bidder has quoted higher in online sealed bid in comparison to envelope sealed bid for any item(s), the bidder will be issued a warning letter to this effect. However, if the same bidder again defaults on this count in any subsequent tender in the unit, it will be considered as fraud and will invite action by BHEL as per extant guidelines for suspension of business dealings with suppliers / contractors (as available on www.bhel.com).

As a reminder to the bidders, system will flash following message (**in RED Colour**) during the course of ~~online~~ sealed bid

~~Bidders~~ to submit online sealed bid less than or equal to their envelope sealed bid already submitted to BHEL+

Signature of the Bidder with Stamp

GST COMPLIANCE FOR INDIGENOUS SUPPLIERS

1. In Response to Tenders for Indigenous supplier will be entertained only if the vendor has a valid GSTIN which should be clearly mentioned in the offer. If any specific exemption is available, a declaration with due supporting documents need to be furnished for considering the offer.
2. Supplier shall mention their GSTIN in all their invoices and invoices shall be in the format as specified/prescribed under GST laws. Invoices shall necessarily contain Invoice number (in case of multiple numbering system is being followed for billing like SAP invoice no, commercial invoice no etc., then the Invoice No which is linked/uploaded in GSTN network shall be clearly indicated), item description as per PO, Quantity, Rate, Value, applicable taxes with nomenclature (like IGST, SGST, CGST & UTGST) separately, HSN/ SAC Code, etc.
3. All invoices shall bear the HSN Code for each item separately (Harmonized System of Nomenclature)/ SAC code (Services Accounting Code).
4. A declaration to the effect that all invoice particulars are/were uploaded in the GSTN network/ portal & all tax liability as per GST rules and regulations have been and will be discharged, shall be mentioned in the invoice. If not mentioned in the invoice, a separate declaration shall be submitted as per the requirement of BHEL.
5. All documents like Test Certificate, LR copy, Guarantee/Warranty certificate, work completion certificate, any other document mentioned in PO, shall be sent along with the vehicle/consignment where ever applicable. For all consignments received within the calendar month, input credit will be availed within that month in line with monthly returns filing cycle. In case of any discrepancy in the document or non-submission of documents mentioned in the PO, then BHEL will not be able to accept or account the material, in such case availing of tax credit will be deferred to next month or so.
6. In case of discrepancy in the data uploaded by supplier in the GSTN portal or in case of any shortages or rejection in the supply, then BHEL will not be able to avail the tax credit and will notify the supplier of the same. Supplier has to rectify the data discrepancy in the GSTN portal or issue credit note (details to be uploaded in GSTN portal) for the shortages or rejections in the suppliers, within the calendar month notified by BHEL.
7. For any such delay in availing of tax credit for reasons attributable to supplier (as mentioned above), interest (calculated @ SBI Base Rate + 6%) along with penalty if any will be deducted for the delayed period i.e. from the month of receipt till the month tax credit is availed, from the running bills.
8. Under GST regime, BHEL has to discharge GST liability on LD recovered from suppliers/contractors. Hence applicable GST shall also be recoverable from suppliers/contractors on LD amount. For this Debit note will be issued by BHEL indicating the respective supply invoice number.
9. This is to inform that GST portion of invoice, shall be released only upon Vendor declaring such invoice in his GSTR-1 and receipt of goods and Tax invoice by BHEL and Confirmation of payment of GST thereon by vendor on GSTN portal. Alternatively, BG of appropriate value may be obtained from vendor which shall be valid At least one month after the confirmation of date of payment of GST by vendor on GSTN portal and receipt of Tax invoice and receipt of goods, whichever is later. Above is subject to receipt of goods/service and tax invoice thereof along with vendor declaring invoice in his return and paying GST within timeline prescribed for availing ITC by BHEL.
10. That in case vendor delays Declaring such invoice in his return and GST credit availed by BHEL is denied or reversed subsequently as per GST law, GST amount paid by BHEL towards such ITC reversal as per GST law shall be recoverable from vendor/contractor along with interest levied/ leviable on BHEL.

Note : The above will be followed strictly for processing vendor payments to ensure GST Compliance.

Signature of the Bidder with Stamp

CAUTION : The information on this document is the property of BHARAT HEAVY ELECTRICALS LTD. It must not be used directly or indirectly in any way detrimental to the interest of the company.

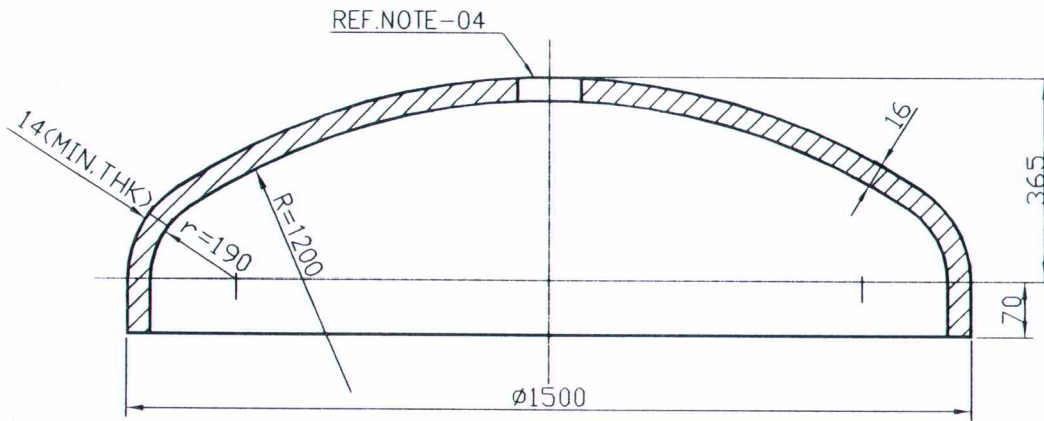

NOTES: -

01. ALL DIMENSIONS ARE FINISHED DIMENSIONS.
02. EDGE PREPARATION FOR BUTT WELDING SHALL BE AS PER CONTRACT DRAWINGS.
03. THE DIMENSION 70mm. INDICATED FOR THE SKIRT IS INCLUSIVE OF MANUFACTURING TOLERANCE FOR EDGE PREPARATION. FINAL REQUIRED DIMENSION WITH EDGE PREPARATION IS 50mm.
04. DEPENDING UPON THE PROCESS OF MANUFACTURE, A PILOT HOLE OF $\phi 20$ mm. (MAXIMUM) MAY BE PERMITTED AT THE LOCATION SHOWN.THE PILOT HOLE SHALL BE CLOSED BY WELDING AND RADIOGRAPHED.
05. DESIGN PRESSURE AT 343° C : 9 Kg/Sq.Cm.
06. FOR QUALITY CONTROL PROCEDURE REFER SIMH:QPC:01
07. MANUFACTURING, INSPECTION AND TESTING SHALL BE AS PER IBR.
08. RADIOGRAPHY OF WELD SEAM BEFORE HEAT TREATMENT SHALL BE 100%.
09. HEAT TREATMENT : STRESS RELIEVING SHALL BE DONE AFTER FORMING.

VARIANT NO.	DESCRIPTION	STD	PLATE 16 x $\phi 1860$	A	UNIT	341.00
			SA 515 Gr.70			UNIT WT(kg)
			MATERIAL CODE			QUANTITY
			MATERIAL SPECN			

REV NO.	BRIEF RECORD OF REVISIONS	PPD.	CHD.	APPD.
---------	---------------------------	------	------	-------

<p>Bharat Heavy Electricals Ltd UNIT: HEAVY PLATES & VESSELS PLANT VISAKHAPATNAM-530012</p>		DRN	S.SATYANARAYANA MURTY	SIGNATURE	DATE	02.08.2018
		CHD	D.SATISH		02.08.2018	
		APPD	A.N.V.K.KISHORE		02.08.2018	
DEPT	ALL DIMENSIONS ARE IN MM	PROJECTION	SCALE	WEIGHT (Kg)	REF TO ASSY / OLD DWG	
CODE			N.T.S		-	
TITLE				DRAWING NO :	REV	
TORI SPHERICAL DISHED END $\phi 1500 \times 16$				4-81-026-U8076	00	

FORM NO 0420/2

CAUTION : The information on this document is the property of BHARAT HEAVY ELECTRICALS LTD. It must not be used directly or indirectly in any way detrimental to the interest of the company.

DESIGN PRESSURE: 9 kg/Sq.Cm.(g)

DESIGN TEMPERATURE: 343°C

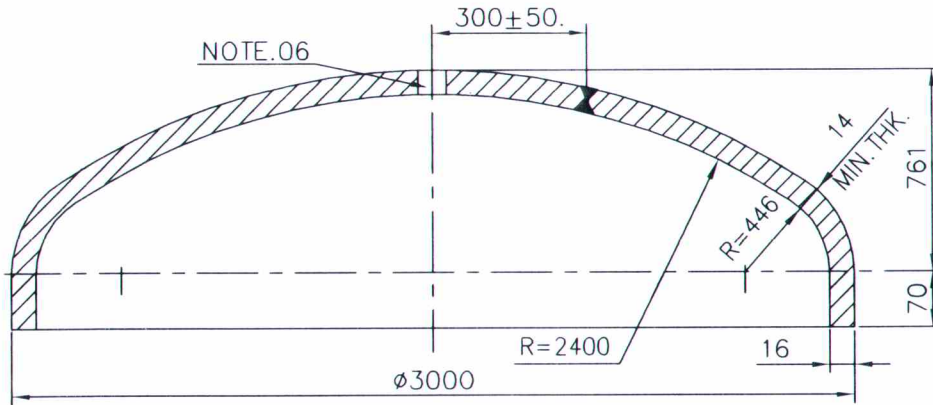

NOTES:

01. ALL DIMENSIONS ARE FINISHED DIMENSION. ONE WELD SEAM IS PERMITTED TO BUILD UP BLANK. THE SEAM IS TO BE IN ACCORDANCE WITH IBR REGULATION 365. ONLY CHORDAL SEAM IS PERMITTED. CROWN & PETAL SEAMS ARE NOT PERMITTED.
02. MANUFACTURING, INSPECTION AND TESTING AS PER IBR.
03. WELD SEAM TO BE EDGE PREPARED AS DOUBLE V
04. RADIOGRAPHY OF WELD SEAM, BEFORE HEAT TREATMENT, IS TO BE 100%
05. HEAT TREATMENT & STRESS RELIEVING IS TO BE DONE AFTER WELDING & FORMING.
06. DEPENDING UPON THE PROCESS OF MANUFACTURE, A PILOT HOLE OF $\phi 20$ mm MAXIMUM MAY BE PERMITTED AT THE LOCATION SHOWN. THE PILOT HOLE SHALL BE PLUGGED, SEAL WELDED AND RADIOGRAPHED.
07. MECHANICAL TESTING IS TO BE DONE ON WELD FOR TEST PIECE AS PER IBR.
08. FOLLOW QUALITY CONTROL PROCEDURE AS PER QAP
09. EDGE PREPARATION SHALL BE AS PER CONTRACT DRAWINGS.
10. THE DIMENSION 70 MM INDICATED FOR THE SKIRT INCLUSIVE OF MFG. TOLERANCE FOR EDGE PREPARATION. FINAL REQUIRED DIMENSION WITH EDGE PREPARATION IS 50 MM.

	PLATE 16 x $\phi 3850$				1462
			SA515GR70	A	
VAR. NO.	DESCRIPTION	STD	MATL. CODE	A/C	UNIT
			MATL. SPECN	D	QTY.

REV NO.	BRIEF RECORD OF REVISIONS	PPD.	CHD.	APPD.
---------	---------------------------	------	------	-------

<p>Bharat Heavy Electricals Ltd UNIT: HEAVY PLATES & VESSELS PLANT VISAKHAPATNAM-530012</p>		DRN	S.SATYANARAYANA MURTY	SIGNATURE	DATE	02.08.2018
		CHD	D.SATISH		02.08.2018	
		APPD	A.N.V.K.KISHORE		02.08.2018	
DEPT	ALL DIMENSIONS ARE IN MM	PROJECTION	SCALE	WEIGHT (Kg)	REF TO ASSY / OLD DWG	
CODE			N.T.S	1462	—	
TITLE				DRAWING NO :	REV	
TORI SPHERICAL DISHED END OD3000 x 16				4-81-026-U8063	00	

FORM NO. 0420/2