



INVITATION TO TENDER

Ref : OS/19-20/7874/19/046

Date : 23.08.2019

Sub : Fabrication of C-Type and Ramshorn Hook Bail Arms against S.O. 7874.

Dear Sir,

Sealed tenders are invited for the subject work in **two part bid** system from the **Vendors** who fulfill the following eligibility criteria :

- 1) Bidders shall have an experience of minimum 2 years in fabrication of Structure & machining works or at least one job / work order of similar nature as on 31st July'2019. Bidders shall have to enclose relevant Work Orders and Work Completion Certificates in support of the same.
- 2) Average Annual Turn Over of the bidders for the last 3 years should be Rs.5 Lakhs. Bidders shall enclose IT Returns and other necessary documents in support of the same.
- 3) Bidders shall have to enclose the documents of Firm Registration, Udyog Aadhar, EPF, ESI, PAN & GST.
- 4) The works executed in the name of individual / firm of the tenderer will only be considered for eligibility criteria.

1. VENDOR'S SCOPE OF WORK:

- a) Total Quantity of work to be carried out by the vendors is about 31 MT as detailed below :
 - (1) S.O. 7874 : Bail Arm (185 MT Capacity) . C Type . 1 No. . 16 MT approx
 - (2) S.O. 7874 : Bail Arm (185 MT Capacity) . Ramshorn Hook Type . 1 No. . 16 MT approxFor further details, drawings and documents mentioned in Annexure . It may be referred.
- b) Complete Fabrication of C-Type and Ramshorn Hook Bail Arms which involves various operations like Marking, Cutting, Edge Preparation, Machining, Drilling, Assembly / Fit-Up, Welding, NDT like LPI, MPI, Radiography, Ultrasonic Testing (wherever required) as per applicable Drawings, GMS, QAP & WPS.
- c) Surface Cleaning by blasting and Painting with Red Oxide Primer as per the applicable Painting Schedule.
- d) Collection of all free issue items, Raw materials & BOCs & Paints etc. from HPVP stores / shops and transportation to Vendor's works, Transportation & handing over of finished items to HPVP Logistics dept. and excess / balance materials at HPVP stores
- e) The fabricated items shall strictly conform to the dimensions and tolerances indicated in the drawings. It must be ensured that correct dimensions and deviations, if any, are recorded properly and is made available to BHEL officials or their authorized agencies.
- f) Vendor's scope includes rectification of raw materials such as straightening etc. if any and trial assembly after fabrication wherever required as per Drawings / QAP and rectification of defects, if any attributable to vendors, found after handing over to Logistics dept.
- g) Free issue materials should be collected within 3 days from the date of clearance by QC (stores) without failure. Any delay beyond 3 days shall be considered for levying of LD.
- h) Submission of economic cutting plans for all plate materials and sections issued by BHEL and obtaining approval of competent authority is mandatory before taking up fabrication.

Contd...2

- i) Wherever fabrication is done without proper approved cutting plans, any loss of materials arising due to the same will be recovered as per BHEL recovery rates.
- j) No extra rates are applicable for the additional joints to be made in Plates / Rolled sections.
- k) The work is to be executed as per the latest approved Drawings, Group Manufacturing Specification (GMS), Shipping List, QAP, WPS, Specifications etc.
- l) Adequate facilities like welding equipments, baking oven, handling facilities and measuring instruments duly calibrated must be available with the vendor. All the above equipments must be under working condition and relevant documents for the same are to be made available for verification by BHEL - HPVP / TPI Officials or their authorized agents.
- m) The fabricated items shall strictly conform to the dimensions and tolerances indicated in the drawings. It must be ensured that correct dimensions and deviations, if any, are recorded properly and is made available to BHEL officials or their authorized agencies.
- n) All indirect materials, consumables like electrodes, gases, grinding wheels etc. required for fabrication are in the scope of the Vendor. In general, 7018 electrodes shall have to be used in the fabrication unless otherwise specified in the WPS.
- o) Identification of all items shall be hard stamped by encircling with paint and stenciled in a specific format with details of Project name, Customer No., Work Order No., PGMA No., DU No., Qty., Weight etc., for identification and dispatch as per the instructions of the concerned. Completed job without proper identification will not be accepted by HPVP - Stores / Logistics dept.
- p) Vendors shall have to return the excess / balance materials including off-cuts and total scrap available with the vendors exclusive of process allowance & invisible wastage to HPVP Stores after material reconciliation but before submission of their final bill. In case the same are not returned by the vendors, Recovery shall be made as per BHEL Rates / MSTC rates plus applicable taxes, prevailing at the time of processing of the final bills.
- q) Hydra Crane, Chains / Slings required for fabrication, loading & unloading at vendor's works etc. are in the scope of vendor.
- r) Qualified Engineers & Supervisors shall be deployed for proper co-ordination of the job.
- s) In case of requirement of off-cut materials, the vendor shall have to arrange for Gas Cutting at BHEL Stores.
- t) Though not mentioned specifically, any activity which is required for completion of the work as per the drawings and QAP is deemed to be included in the scope of work of vendor. Any modification work due to revision of drawings during fabrication is to be carried out by the vendor without any extra cost.

2. BHEL's SCOPE :

BHEL shall supply the following as free issue :

- i) Plates in full / off-cuts & Fasteners as per Drawings & GMS
- ii) Rods in Running Metres
- iii) Top & Bottom Plates (Part Nos. 2 to 5 of BOM) of C-type Bail Arm in Pressed Condition
- iv) Vertical & Bottom Plates (Part Nos. 1, 4 & 5 of BOM) of Ramshorn Hook Bail Arm in Pressed Condition
- v) Paints and other items as per GMS
- vi) Drawings, GMS, QAP, WPS and Painting Schedule etc.

3. LOCATION OF WORK SPOT :

The fabrication work is to be carried out **at Vendor's works.**

4. INSPECTION :

Inspection shall be carried out by M/s. BHEL / BHEL Authorized Inspection Agency as per approved QAP.

5. DELIVERY :

Finished items along with inspection documents and all other relevant certificates are to be handed over to Logistics dept. within **8 weeks** from the date of issue of last consignment of raw materials.

6. VALIDITY OF OFFER :

The offer shall be valid for a period of **3 months** from the last date for tender submission.

7. PRICE :

The prices shall be quoted for the detailed scope of work in the Schedule of Rates enclosed at Annexure . I & II. The prices shall be fixed & firm without any escalation during the entire period of contract and till completion of the work.

The quoted price shall be **inclusive of all applicable taxes & duties except GST and** GST shall be reimbursable to the vendor as detailed in Clause . 8. Income tax shall be deducted at applicable rates from the vendor's bills.

8. GOODS & SERVICES TAX (GST) :

Bidders shall make a note of the following points of GST before submission of their offer :

- Vendors registered under GST Act shall have to mention their GSTIN no. (15 Digits) in their Technical Bid. If any specific exemption is available, a declaration with due supporting documents need to be furnished for considering the offer.
- Semi-finished goods are to be delivered by the Vendors in BHEL, HPVP premises within a maximum period of one year from the date of issue of the material, failing which the whole transaction will be considered as Supply and Sale and GST is required to be paid along with interest (calculated @ SBI Base Rate + 6%) along with penalty, if any, from the date of Challan on the whole value of materials. Hence vendors shall have to ensure that materials issued to them are returned within 365 days.
- After fabrication, the vendors shall have to deliver the Semi-finished Goods by fulfilling the following formalities :

GST invoice should be raised by the vendors by paying GST on job work charges at applicable rates and by incorporating the HPVP GSTIN no. in the invoice for availing the reimbursement of GST from HPVP.

The vendor shall also have to enter in their GST Return -1 (GSTR-1) the details of invoice raised for payment of GST so as to enable HPVP to avail input tax credit.

9. REVERSE AUCTION :

BHEL reserves the right to opt for Reverse Auction at its discretion instead of opening the price bids submitted in sealed envelope and any information regarding the reverse auction shall be decided after technical evaluation and shall be intimated to the bidders at appropriate time.

The bidders are advised to give their acceptance for participation in RA. Non-acceptance to participate in RA may result in non-consideration of their bids in case BHEL decides to go for RA.

In case BHEL decides to go for RA, only those bidders who give their acceptance will be allowed to participate in RA and these bidders shall have to necessarily submit sOnline Sealed Bid in the RA. Non-submission of sOnline Sealed Bid by the bidder will be considered as tampering of the tendering process and will invite action by BHEL as per extant guidelines in vogue.

10. RISK PURCHASE :

In case the contractor fails to execute the work within the scheduled time or due to any other reasons, BHEL - HPVP reserves the right to get the same completed through some other party at the risk & cost of the contractor and any additional expenditure incurred due to the same shall be charged to the contractor.

11. Other Terms & Conditions shall be as per Annexure –III enclosed.

12. GENERAL :

a) The bidders shall study the Tender documents, Drawings, Quality Documents and all other relevant documents in detail for understanding the scope of work and the processes involved before submission of offer. One complete set of drawings shall be made available in the office of DGM (Outsourcing) and the same shall be referred during working hours.

For any clarifications required on this tender document, scope of work etc., the bidders shall depute their authorized representatives to BHEL, Visakhapatnam with prior intimation to get clarifications from concerned authorities between 09:00 AM and 04:00 PM.

b) **Bidders shall confirm their acceptance to all the terms & conditions of the tender enquiry. Any deviations to the tender terms & conditions are not acceptable** and BHEL reserves the right to reject such offers without further correspondence.

c) BHEL reserves the right to modify in part or full or cancel the tender enquiry at any stage without assigning any reasons thereof.

13. The following documents shall form part of the tender enquiry :

- i) Schedule of Rates : Annexure - I
- ii) Details of DUs to be fabricated & applicable drawings : Annexure – II
(Typical Drawings shall be sent to the bidders by e-mail upon their request)
- iii) General Terms & Conditions : Annexure – III
- iv) Acceptance to tender terms & conditions : Annexure – IV
- v) General Terms & Conditions of Reverse Auction : Annexure – V
- vi) GST Compliance for Indigenous Suppliers : Annexure – GST

14. TENDER SUBMISSION :

Techno-commercial bids shall be submitted along with the **tender document duly signed by the bidder on all pages**. Techno-Commercial Bid and Price bid shall be placed in two separate envelopes and both shall be kept in another big envelope.

Tenders completed in all respects shall be dropped in the **Outsourcing Tender Box** placed at Reception counter, Admn. Building, BHEL - HPVP, Visakhapatnam latest by **14.00 hrs. on or before 05.09.2019** duly super scribing the Subject, Tender Ref. No. and Technical / Price Bid on the envelopes.

TENDERS RECEIVED AFTER THE DUE DATE & TIME ARE NOT ACCEPTABLE.

Note : Offers sent in any other form will be treated as invalid and will be summarily rejected.

15. OPENING OF TENDERS :

Techno-commercial Bids will be opened on **05.09.2019 at 14.00 Hrs.** at Customer Cell, ADMN. Building, BHEL - HPVP, Visakhapatnam The price bid of the techno-commercially qualified bidders will be opened in presence of representatives of the bidders and the date & time of opening of price bids will be intimated later. The bidders may depute their representatives at the time of opening.

In case of opting for Reverse Auction, intimation shall be given to the qualified bidders in advance at appropriate time.

for Bharat Heavy Electricals Limited,

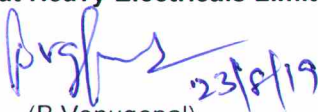
 (B. Venugopal)
 Manager (OS)

Schedule of Rates**Sub :** Fabrication of C-Type and Ramshorn Hook Type Bail Arms against S.O. 7874.**Ref :** OS/19-20/7874/19/046**Date :** 23.08.2019

SOR Item No.	S.O. No.	Description of Item	Unit	Quantity in MT (A)	Unit Rate (in ₹) (B)	Amount (in ₹) (AxB)
1		Fabrication of the following Bail Arms as detailed in annexure - II, which involve major operations like Marking, Cutting, Edge Preparation, Machining, Drilling, Assembly/Fit-up, Welding etc. as per applicable Drawings, GMS, Shipping List, QAP & WPS and as per detailed scope of work mentioned in the tender document.				
1.1	7874	C - Type Bail Arm	MT	16		
1.2		Ramshorn Hook Type Bail Arm	MT	16		
		TOTAL		32		

Notes :

- 1) **L1 Status will be evaluated on total quoted value and there will be no distribution of work.**
- 2) The quantity and weights indicated above are tentative and may vary slightly on both sides depending upon requirement at the time of ordering / execution or due to revision of drawings / Engg. details. However, payment shall be made for the actual quantities / weights only.
- 3) The quoted price shall be inclusive of all applicable taxes & duties except GST GST shall be reimbursable to the vendor as detailed in Clause – 8. Income tax shall be deducted at applicable rates from the vendor's bills.
- 4) The prices shall be fixed & firm without any escalation during the entire period of contract and till completion of the work.
- 5) The bidders are advised to go through all the drawings & documents before quoting the tender.
- 6) BHEL reserves the right to go for Reverse auction as per the applicable guidelines instead of opening price bids.
- 7) Tenderer should quote the amount in figures & words. It may be noted that corrections, overwriting etc. are not allowed. If there is a discrepancy between amount in figures & words, the amount in words shall prevail unless the amount expressed in words is related to an arithmetic error, in which case the amount in figures shall prevail. If there is an error in the total corresponding to the addition or subtraction of sub-totals, the sub-totals shall prevail and total shall be corrected accordingly.

In case of any mismatch between quoted rate and amount in figures, rate in figures shall be taken into consideration for further evaluation and processing.

Signature of the Bidder with Stamp

ANNEXURE-II

DETAILS OF ITEMS TO BE FABRICATED & RELEVANT DRAWINGS

Ref : OS/19-20/7874/19/046

Date : 23.08.2019

Sl. No.	S. O.	PGMA	DU No.	Description of Item	Drawing No.	Rev.
1	7874	BA-001	01	Bail Arm - C Type	1-LD-001-U0010	00
2		BA-002	01	Bail Arm - Ramshorn Hook Type	1-LD-001-U0011	00
3				Bail Arm - Ramshorn Hook Type	1-LD-001-U0012	00
4				Manufacturing Quality Plan	CQP:2481	00

Note : The quantity and weights indicated above are tentative and may vary slightly on both sides depending upon requirement at the time of ordering / execution or due to revision of drawings / Engg. details.

GENERAL TERMS & CONDITIONS**1. TECHNICAL DELIVERY CONDITIONS :**

The work should conform to the technical data given in our drawings, GMS, Shipping List Specifications, QAP, WPS etc.

2. PARTY'S SCOPE :

The scope of the party shall be as follows: -

- a) All welding equipments, baking oven, tools, jigs and fixtures, measuring instruments duly calibrated, handling facilities, testing facilities etc.
- b) All materials other than those mentioned under "Free Issue Materials", which are required for completion of the work.
- c) All consumables such as electrodes, gases, grinding wheels etc.

Note : Electrodes of specification mentioned in the drawings / WPS and of BHEL approved brands only shall be used.

3. REVISION OF DRAWINGS :

There may be minor changes in the drawings during execution. In such a case, party should accommodate the same without any extra claim.

4. WELDING QUALIFICATION : Qualification of required number of Welders is party's responsibility at their cost.**5. X-RAY :**

All welding shall be of X-ray quality where specified on drawings. Inspection would specify the quantum of X-ray based on drawings / code requirement. Party should strictly follow the WPS and QAP supplied by BHEL during welding. Getting the welds radiographed and getting them cleared by inspection is the responsibility of the party.

6. RECTIFICATIONS / REJECTIONS :

Any rectification due to defective work, if required, shall be done by the party free of charge with a suitable technology approved before hand by BHEL in writing. The cost of material, if any used for rectification work / rejection work, will be estimated by BHEL and the same shall be debited to party's account. In case any rectification / rework is to be carried out due to defective material supplied by BHEL, the replacement material and consumables will be supplied by BHEL free of Cost.

7. SECURITY DEPOSIT :

Vendors shall have to submit a Bank Guarantee for **10%** of the order value in case of **HPVP ADM site** or **25%** of the material cost in case of Vendor works towards Security Deposit and safe custody of materials within one week from the date of issue of Order. The BG shall be valid for the contract period with a claim period of 3 months. This Bank Guarantee shall be released to the contractor after completion of work and on acceptance of the same by BHEL / Owner and on submission of Performance BG for 10 % of the order value covering for the defects liability period. If PBG is not submitted, 10% of the order value shall be deducted towards PBG from final bill.

8. RAW MATERIALS ISSUE :

Raw materials shall be issued with appropriate processing allowance and invisible wastage over the theoretical requirement of raw materials (**Plates, Sheets, Sections and Pipes**).

9. TRANSFER / RETURN OF LEFT OVER MATERIALS :

Party should maintain proper records for receipt & use of all free issue materials. The left over materials & scrap as per the material accounting statement shall be returned to HPVP stores along with finished job. Material Transfer Vouchers (MTV) from one order to another or from one vendor to another and Material Return Vouchers should be submitted immediately after transfer / return. The material reconciliation statement shall be submitted by the contractor after verification and certification by BHEL along with the final bill **within 30 days from the date of completion of work**. Otherwise, recovery for the balance materials shall be made from any of their pending bills without further intimation.

10. MATERIAL RECONCILIATION :

Orders issued to the vendors have to be completed in all respects including Material Accounting within a maximum of **180 days** from the **date of issue of the first material** from BHEL - HPVP stores. This is a statutory requirement under Central Excise Rules and must be strictly complied with.

Maximum of 0.5 % on the requirement of materials (**Plates, Sections and Pipes**) is admitted towards **process allowance and invisible wastage**.

Scrap quantity is permissible up to a **maximum of 1% on Structural (Beams, Channels, Angles, Rods, Pipes etc.), 2% on Sheets, 3% for Plates** on the theoretical requirement of materials.

If wastage and scrap is beyond the above limits, it should be fully justified with cutting diagrams etc. which are to be approved in advance by BHEL. **Otherwise, the cost of raw materials beyond approved limits will be recovered from the contractor as per BHEL recovery rates including applicable taxes & duties.**

Material reconciliation including return of balance materials, off-cuts is to be completed within 20 days from the date of completion of the order. The material reconciliation statement shall be submitted by the contractor after verification and certification by BHEL-HPVP along with the final bill **within 30 days from the date of completion of work**. Otherwise, recovery for the balance materials shall be made from any of their pending bills without further intimation,

Repeated occurrence of inordinate delays in returning and settling the material accounting will entail BHEL the right to terminate the contract forthwith or impose a temporary suspension on further loading at the discretion of BHEL.

11. SCRAP & OFFCUT NORMS :

SI. No.	Description	Scrap Size (in mm)	Off-Cut (in MM)
1.	CS/AS Sheets & Plates	Below 500 × 250	500 × 250 & above
2.	Rolled sections Rod, angles etc. (other than -tubes, pipes)	Below 1000	1000 & above
3.	Tubes & Pipes	Below 500	500 & above
4.	Universal column	Below 1000	1000 & Above
5.	SS Sheets & Plates	Below 500 × 250	500 × 250 & above
6.	SS Structural, Rods, Tubes, Pipes	Below 250	250 & above
7.	Non – ferrous: sheets & plates, rods & tubes	Below 500 × 250 (S & PL), Below 250 (Rods & Tubes)	500 × 250 & above, 250 & above
8.	Big size Scrap	(2500 & above) × (150 to 249)	-

12. INSPECTION :

Party shall contact our Quality Control Dept. for stages of inspection before commencement of job and should strictly follow the stages of inspection as per QAP.

13. WORKMANSHIP GUARANTEE :

The vendors should give workmanship guarantee for fabricated items for a period of 18 months from the date of last delivery of the order. Any defects due to incomplete work, faulty workmanship found in the fabricated items after delivery during the defects liability period shall be rectified / replaced by the vendor free of cost. Otherwise, the expenditure incurred towards the same will be recovered from the pending bills of vendors.

14. WORK PROGRESS :

The fabricator shall furnish a weekly report on the progress of work along with the status of availability of free issue materials and requirement of further materials, if any.

Outsourcing dept. personnel will visit vendor's works from time to time to assess and review the work progress. Free access shall be provided to BHEL or its inspection agency at all reasonable times of the day / night.

In case the progress is not satisfactory or supplies are delayed abnormally beyond the contractual delivery date, BHEL-HPVP, Visakhapatnam reserves the right to cancel the order in part or full or get the balance job in as is where is condition completed elsewhere by another agency at the risk and cost of Fabricator. The value of the work carried out by the party will be assessed by BHEL and the same shall be final. No compensation will be given to the fabricator in case of cancellation of order or diversion of balance job even if the jobs have been processed partly.

15. DELIVERY :

Finished items should be handed over to the Logistics dept. on party's delivery challans along with Job completion certificate / Final Inspection Report from inspection agency / HPVP-QC department.

16. PENALTY :

If delivery exceeds the stipulated delivery schedule, penalty 1/2 % of the total value of order per week or part there of subject to a maximum of 10% on the total value of the order will be levied. However, time taken for the following will not be considered as delay on the part of the Sub-Contractor.

- 1) Intermediate operations, if any, carried out by BHEL.
- 2) Waiting time for BHEL / Third party Inspection beyond a normal time of 3 days.

17. PAYMENT TERMS :

100% payment will be made against delivery of the finished items duly inspected & cleared by Inspection authority along with all inspection documents to Logistics Dept. Payment shall be made within **45 days** from the date of submission of RA Bill.

Only one bill will be admitted for orders with value less than Rs. 5 lakhs and a maximum of two bills are allowed for orders of value more than Rs. 5 lakhs. In such cases, the first bill value shall be restricted to a maximum of 50 % of the order value and a minimum of 50% of the total DUs of the order.

Vendors shall have to submit the bills in the formats specified by HPVP-Outsourcing and the bills submitted in the specified format along with necessary supporting documents are only admitted for processing. The following documents shall be submitted along with the Final Bill: -

1. No Claim Certificate from the contractor
2. No Dues Certificate from BHEL
3. Work Completion Certificate from BHEL
4. Material Reconciliation Statement submitted by the Contractor and certified by concerned authority of BHEL (if applicable)
5. Workmanship Guarantee certificate from the contractor

18. SECRECY :

All the documents of BHEL inclusive of Drawings, GMS and Standards made available to the fabricator should be kept in strict confidence and under no circumstance be made available to others or allow others to make use of them. Such documents shall be returned to BHEL on demand after completion of the job. This secrecy clause is binding on the employees of the fabricators also. Violation of the same may lead to suspension of business with the vendor and necessary legal action.

19. SUB-LETTING :

In general, sub-letting of jobs will not be permitted. But in special circumstances, this may be allowed. In such case, the party should obtain written approval from BHEL-HPVP, Visakhapatnam before sub-letting.

20. FACTORY RULES AND REGULATIONS :

Party shall abide by all the rules and statutory regulations in force from time to time as per factories act. It shall be party's responsibility to ensure the safety of their workmen and fulfilling the ESI, PF and other relevant statutory regulations.

21. SAFETY :

- a) Contractor shall adhere to safe construction practices, guard against hazardous & unsafe working conditions and shall comply with the safety rules of BHEL and local authorities. He shall maintain First Aid facilities for all his employees and labour. Contractor's responsibility includes supply of welder kit, all safety items such as safety belts, white and colour glasses, goggles, safety helmets, safety shoes etc.
- b) *Contractor and his employees shall follow all fire & safety, security regulations of BHEL.*

22. HOUSE KEEPING :

During execution of work, the contractor at all times keep the working place and storage area clean and free from accumulation of waste materials, rubbish etc.,

23. ACCIDENT / DAMAGE / CONDUCT ETC. :

Contractor will be held responsible for any disorderly conduct / misconduct, indiscipline, theft, smoking etc., on the part of his men. He will ensure summary eviction of such men from his premises failing which BHEL would remove them from the factory on his responsibility. Any damage to and or loss of equipment, machinery, building etc., to BHEL or BHEL employees, visitors or other contractors resulting from his own or any of his men's negligence shall be liable to be made good by him. Contractor shall be solely responsible for any accident in which you or your men or your equipment may be involved during the execution of contract on account of any reason what so ever.

24. TERMINATION OF CONTRACT :

In the event of any failure on the part of the contractor, BHEL reserves the right to terminate the contract by giving a notice of 2 weeks for any of the following lapses and contractual violations: -

- a) Failure to make labour payments in time as per the rules
- b) Failure to progress the job according to the agreed schedule
- c) Failure to mobilize adequate man power, tools & tackles and consumables in time
- d) Failure to adhere to Quality Standards of BHEL
- e) Refused to co-operate with other agencies working in the same area
- f) Failure to resolve labour disputes like strikes etc., within 7 days of occurrence
- g) Failure to comply with statutory regulations applicable at BHEL

BHEL shall also be free to intervene and take necessary remedial measures. All costs incurred with interest and overheads shall be recovered from contractor by such foreclosing or off-loading any part of the contract work.

25. DISPUTES :

Head of BHEL- HPVP Unit will be the final authority for any disputes arising out of this contract. The disputes / arbitration / settlement of contractual or legal issues shall be under the Jurisdiction of Visakhapatnam Court.

- 26.** For this procurement, Public Procurement (Preference to Make in India), Order 2017 dated 15.06.2017 & 28.05.2018 and subsequent Orders issued by the respective Nodal Ministry shall be applicable even if issued after issue of this NIT but before finalization of Contract / PO / WO against this NIT.

In the event of any Nodal Ministry prescribing higher or lower percentage of purchase preference and / or local content in respect of this procurement, same shall be applicable.

Signature of Bidder with Stamp

Acceptance to Tender Terms & Conditions

I / We hereby confirm that the Tender documents, Drawings, Quality documents etc. have been studied in detail and we have fully understood the scope of work.

I / We accept to all the Terms and Conditions of the Tender Enquiry and the prices quoted are in accordance with the same.

I / We give our acceptance to participate in reverse auction in case BHEL decides to opt for reverse auction for this tender.

Tender documents duly signed on all the pages by the Owner / authorized representative of the bidder are attached herewith.

Signature of the Bidder with Stamp

GENERAL TERMS AND CONDITIONS OF RA (REVERSE AUCTION)

BHEL reserves the right to go for Reverse Auction (RA) (Guidelines as available on www.bhel.com) instead of opening the sealed envelope price bid, submitted by the bidder. This will be decided after techno-commercial evaluation. Bidders to give their acceptance with the offer for participation in RA. Non-acceptance to participate in RA may result in non-consideration of their bids, in case BHEL decides to go for RA.

Those bidders who have given their acceptance to participate in Reverse Auction will have to necessarily submit ~~Process compliance form~~(to the designated service provider) as well as ~~Online sealed bid~~in the Reverse Auction. Non-submission of ~~Process compliance form~~or ~~Online sealed bid~~by the agreed bidder(s) will be considered as tampering of the tender process and will invite action by BHEL as per extant guidelines for suspension of the business dealings with suppliers/ contractors (as available on www.bhel.com).

The bidders have to necessarily submit online sealed bid less than or equal to their envelope sealed price bid already submitted to BHEL along with the offer. **The envelope sealed price bid of successful L1 bidder in RA, if conducted, shall also be opened after RA and the order will be placed on lower of the two bids (RA closing price & envelope sealed price) thus obtained. The bidder having submitted this offer specifically agrees to this condition and undertakes to execute the contract on thus awarded rates.**

If it is found that L1 bidder has quoted higher in online sealed bid in comparison to envelope sealed bid for any item(s), the bidder will be issued a warning letter to this effect. However, if the same bidder again defaults on this count in any subsequent tender in the unit, it will be considered as fraud and will invite action by BHEL as per extant guidelines for suspension of business dealings with suppliers / contractors (as available on ww.bhel.com).+

As a reminder to the bidders, system will flash following message **(in RED Colour)** during the course of ~~online sealed bid~~

~~%~~Bidders to submit online sealed bid less than or equal to their envelope sealed bid already submitted to BHEL+

Signature of the Bidder with Stamp

GST COMPLIANCE FOR INDIGENOUS SUPPLIERS

1. In Response to Tenders for Indigenous supplier will be entertained only if the vendor has a valid GSTIN which should be clearly mentioned in the offer. If any specific exemption is available, a declaration with due supporting documents need to be furnished for considering the offer.
2. Supplier shall mention their GSTIN in all their invoices and invoices shall be in the format as specified/prescribed under GST laws. Invoices shall necessarily contain Invoice number (in case of multiple numbering system is being followed for billing like SAP invoice no, commercial invoice no etc., then the Invoice No which is linked/uploaded in GSTN network shall be clearly indicated), item description as per PO, Quantity, Rate, Value, applicable taxes with nomenclature (like IGST, SGST, CGST & UTGST) separately, HSN/ SAC Code, etc.
3. All invoices shall bear the HSN Code for each item separately (Harmonized System of Nomenclature)/ SAC code (Services Accounting Code).
4. A declaration to the effect that all invoice particulars are/were uploaded in the GSTN network/ portal & all tax liability as per GST rules and regulations have been and will be discharged, shall be mentioned in the invoice. If not mentioned in the invoice, a separate declaration shall be submitted as per the requirement of BHEL.
5. All documents like Test Certificate, LR copy, Guarantee/Warrantee certificate, work completion certificate, any other document mentioned in PO, shall be sent along with the vehicle/consignment where ever applicable. For all consignments received within the calendar month, input credit will be availed within that month in line with monthly returns filing cycle. In case of any discrepancy in the document or non-submission of documents mentioned in the PO, then BHEL will not be able to accept or account the material, in such case availing of tax credit will be deferred to next month or so.
6. In case of discrepancy in the data uploaded by supplier in the GSTN portal or in case of any shortages or rejection in the supply, then BHEL will not be able to avail the tax credit and will notify the supplier of the same. Supplier has to rectify the data discrepancy in the GSTN portal or issue credit note (details to be uploaded in GSTN portal) for the shortages or rejections in the suppliers, within the calendar month notified by BHEL.
7. For any such delay in availing of tax credit for reasons attributable to supplier (as mentioned above), interest (calculated @ SBI Base Rate + 6%) along with penalty if any will be deducted for the delayed period i.e. from the month of receipt till the month tax credit is availed, from the running bills.
8. Under GST regime, BHEL has to discharge GST liability on LD recovered from suppliers/contractors. Hence applicable GST shall also be recoverable from suppliers/contractors on LD amount. For this Debit note will be issued by BHEL indicating the respective supply invoice number.
9. This is to inform that GST portion of invoice, shall be released only upon Vendor declaring such invoice in his GSTR-1 and receipt of goods and Tax invoice by BHEL and Confirmation of payment of GST thereon by vendor on GSTN portal. Alternatively, BG of appropriate value may be obtained from vendor which shall be valid At least one month after the confirmation of date of payment of GST by vendor on GSTN portal and receipt of Tax invoice and receipt of goods, whichever is later. Above is subject to receipt of goods/service and tax invoice thereof along with vendor declaring invoice in his return and paying GST within timeline prescribed for availing ITC by BHEL.
10. That in case vendor delays Declaring such invoice in his return and GST credit availed by BHEL is denied or reversed subsequently as per GST law, GST amount paid by BHEL towards such ITC reversal as per GST law shall be recoverable from vendor/contractor along with interest levied/ leviable on BHEL.

Note : The above will be followed strictly for processing vendor payments to ensure GST Compliance.

Signature of the Bidder with Stamp

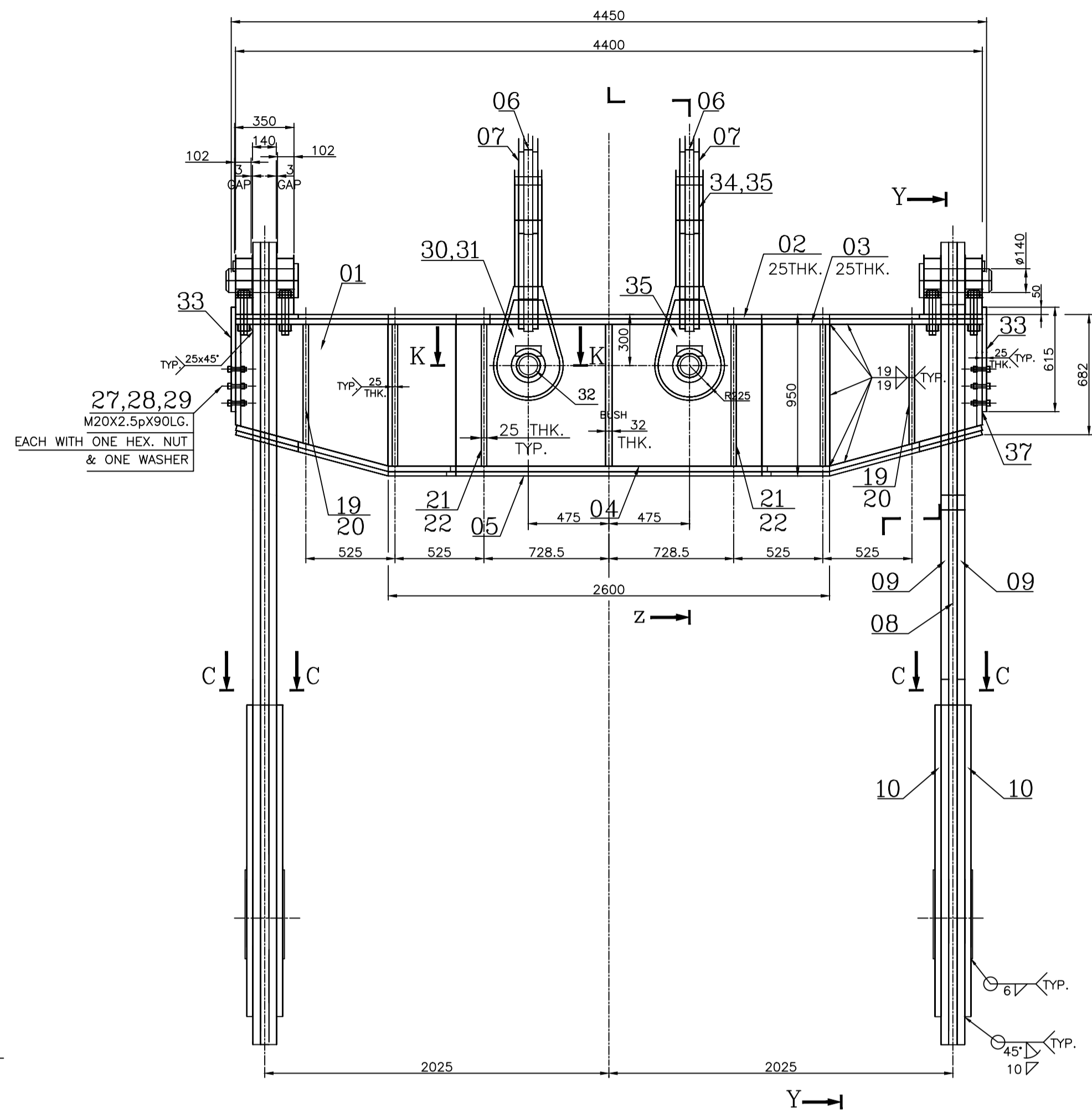

SECTION-XX

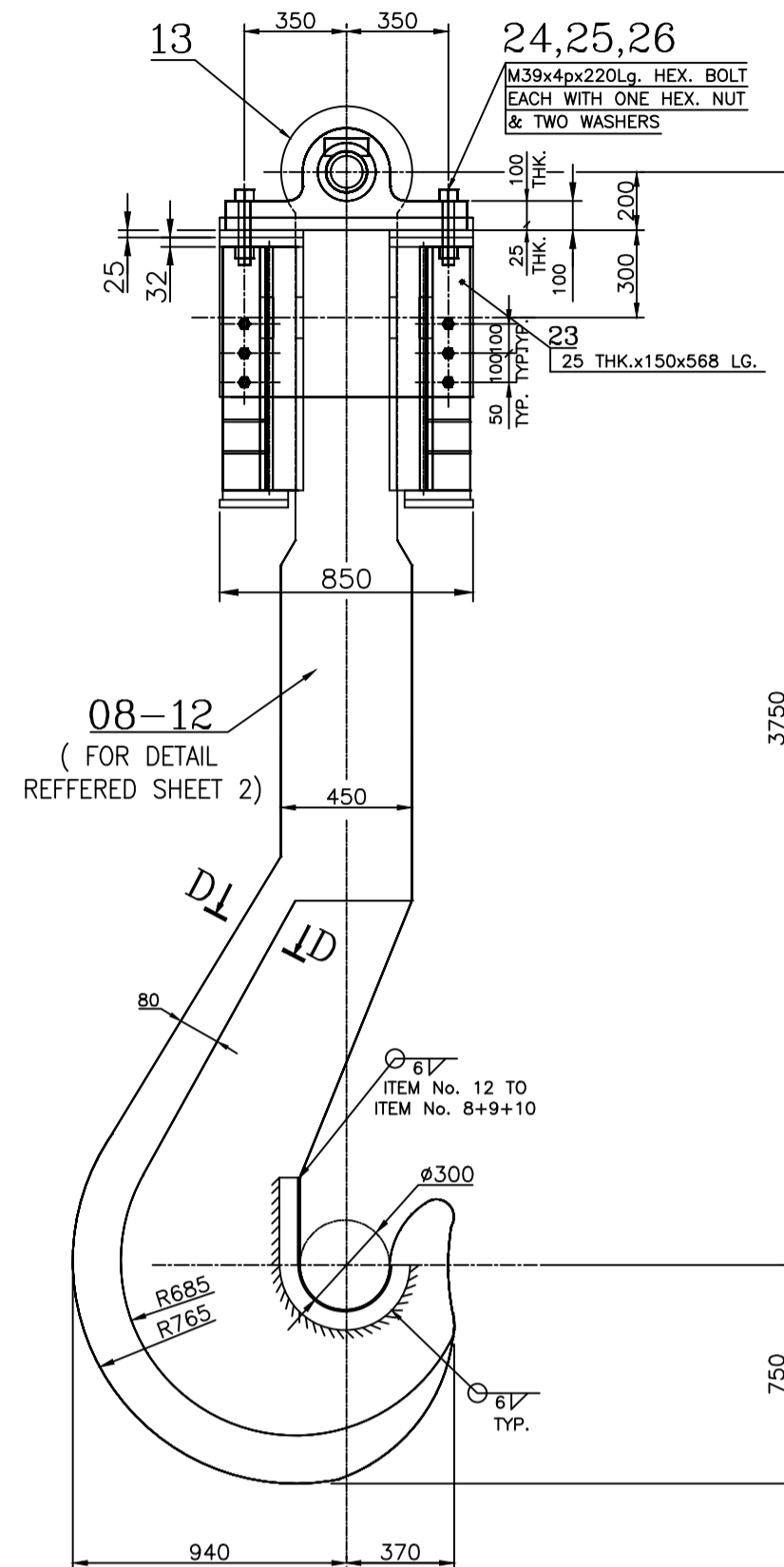

SECTION-YY

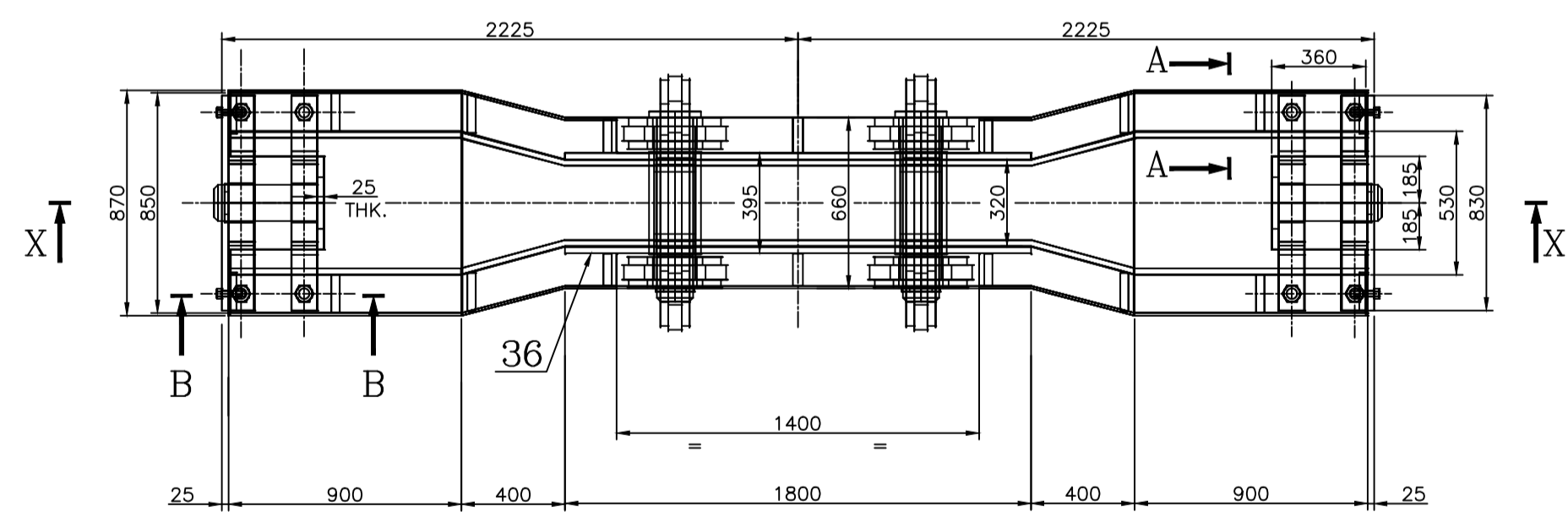

PLAN
HOOK NOT SHOWN

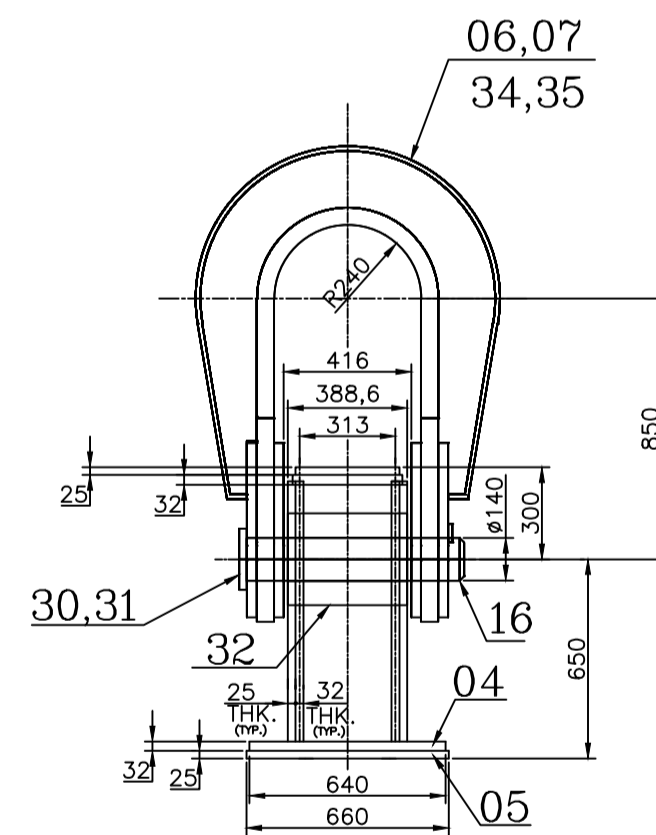

SECTION-ZZ

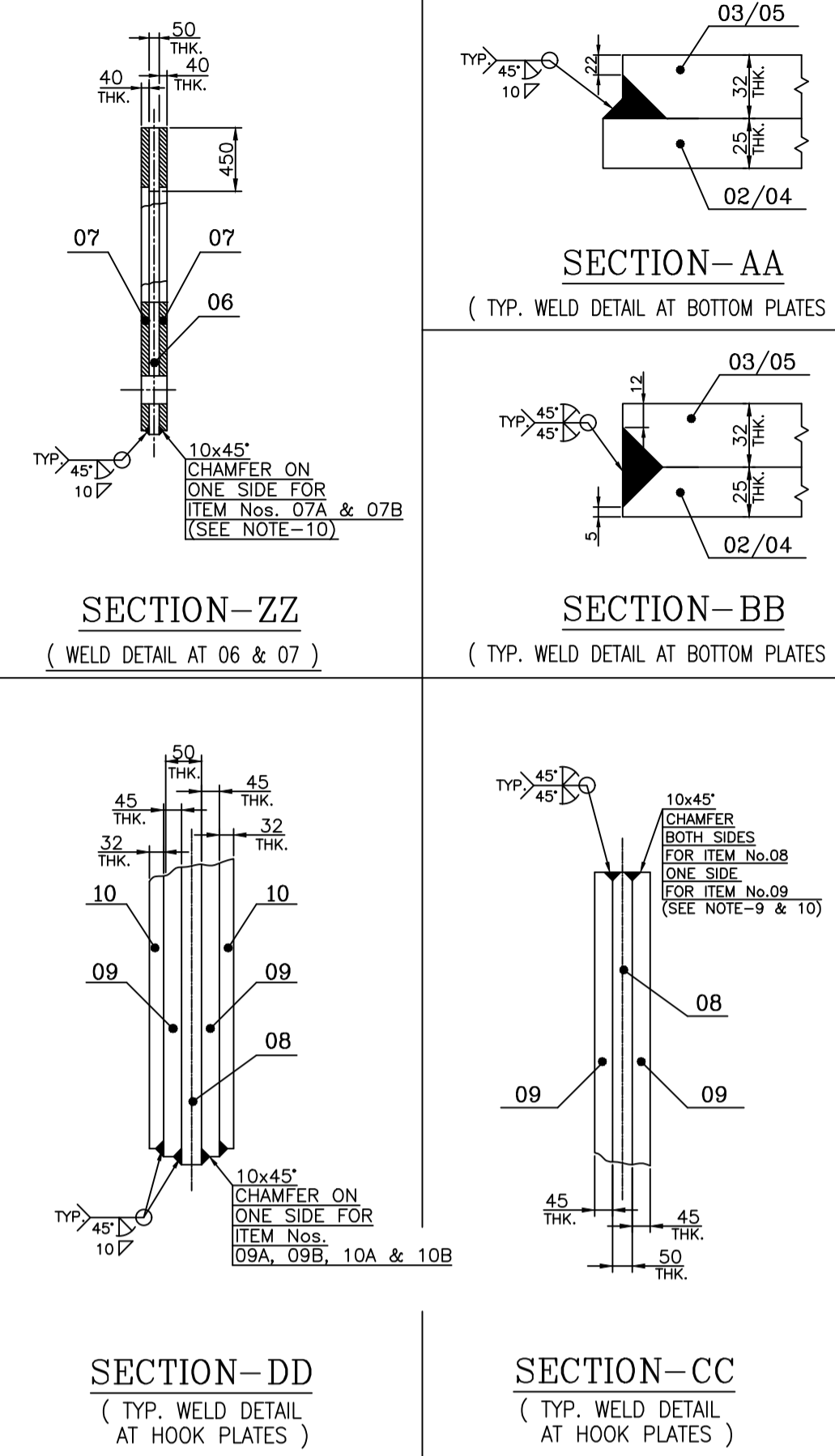

SECTION-DD
(TYP. WELD DETAIL AT HOOK PLATES)

SECTION-CC
(TYP. WELD DETAIL AT HOOK PLATES)

SECTION-KK
(TYP. WELD DETAIL AT LIFTING LUG PIN)

DETAIL OF ITEM NO. 31
(QUANTITY-4 + 2 Nos.)

DETAIL OF ITEM No.14 TO 16

- NOTES :-**
- ALL PLATES & PINS SHOULD BE ULTRA SONICALLY TESTED.
 - FULL WELDING REQUIRED AT ALL PLACES.
 - ALL WELDING JOINTS TO BE SUBJECTED TO D.P. TEST AND FREE FROM ANY WELDING CRACKS.
 - ALL BUTT WELDING JOINTS TO BE WITH PROPER 'V' GROOVE PREPARATIONS.
 - TOP AND BOTTOM FLANGE, WEB PLATE SHOULD BE IN ONE PEACE ONLY.
 - BAIL ARM TO BE MADE AS STRONG WELDED CONSTRUCTION M.S. PLATE ACCORDING TO IS : 2002 / SA 106 GR.70 ULTRASONICALLY TESTED.
 - WELDING THICKNESS SHOULD NOT BE LESS THAN 0.75 TIMES OF PL. THICKNESS.
 - SUITABLE TECHNOLOGICAL ALLOWANCE TO BE TAKEN AS PER REQUIREMENT.
 - a). 10x45° CHAMFERING AND WELDING SHALL BE DONE ALL ROUND UP TO A LENGTH OF 2725m FOR ITEM Nos. 08, 09A, 09B, 10A & 10B AS SHOWN.
b). 10x45° CHAMFERING AND WELDING SHALL BE DONE AT ONE SIDE OF HOOK AREA.
 - GAP BETWEEN PLATES AS SHOWN IN SECTION-ZZ, CC & DD NOT TO EXCEED 0.5 mm AND TO BE CHECKED WITH FILLER GAUGE. LENGTH OF GAPS NOT TO EXCEED 50 mm & DEPTH OF GAP NOT EXCEED 20 mm POINT DISTANCE OF TWO GAPS SHOULD NOT BE LESSER THAN 20 mm.

WEIGHT : 15118.740 Kgs.

ITEM No.	DESCRIPTION	SIZE	QTY.	UNIT WT. IN Kgs.	TOTAL WT. IN Kgs.	CUST. MATL.	REMARKS
37	SUPPORT RIB	25 THK. X 150 X 568 LG.	4	16.720	66.880	SA 516 GR.70	
36	RECTANGLE PLATE	25 THK X 836 X 1800 LG.	2	287.612	575.224	SA 516 GR.70	
35	BEND PLATE	56 THK X 370 X 570 LG.	4	92.711	370.844	SA 516 GR.70	
34	BEND PLATE	56 THK. X 160 X 1454 LG.	2	102.268	204.537	SA 516 GR.70	
33	END PLATE	25 THK X 615 X 830 LG.	2	100.001	200.002	SA 516 GR.70	
32	BUSH	Ø300/Ø142 X 320 LG.	4	123.347	493.388	SA 105	
31	LOCKING PLATE	14 THK. X 60 X 150 LG.	4+2	0.843	5.058	SA 516 GR.70	
30	HEX. BOLT	M12 X 1.75p X 35 LG.	8	0.050	0.400	IS 1367 CL.4.6	
29	WASHER	FOR M20 (O.D.37/I.D.22 X 3.15 THK.)	12	0.017	0.204	IS 2016	
28	HEX. NUT	M20 X 2.5p	12	0.030	0.360	IS 1367 CL.4.0	
27	HEX. BOLT	M20 X 2.5p X 90 LG.	12	0.280	3.360	IS 1367 CL.4.6	
26	WASHER	FOR M39 (O.D.72/I.D.42 X 6 THK.)	16	0.126	2.016	IS 2016	
25	HEX. NUT	M39 X 3.0p	8	0.476	3.808	IS 1367 CL.4.0	
24	HEX. BOLT	M39 X 3.0p X 200 LG.	8	2.532	20.256	IS 1367 CL.4.6	
23	SUPPORT RIB	25 THK. X 147.5 X 568 LG.	4	16.386	65.544	SA 516 GR.70	
22	SUPPORT RIB	25 THK. X 836 X 265 LG.	4	43.477	173.908	SA 516 GR.70	
21	SUPPORT RIB	25 THK. X 836 X 265 LG.	4	43.477	173.908	SA 516 GR.70	
20	SUPPORT RIB	25 THK. X 710 X 265 LG.	2	43.477	86.954	SA 516 GR.70	
19	SUPPORT RIB	25 THK. X 710 X 265 LG.	2	36.924	73.848	SA 516 GR.70	
18	END PLATE	25 THK. X 615 X 850 LG.	2	102.141	204.282	SA 516 GR.70	
17	PIN COLLAR	Ø300 / Ø143 X 14 LG..	2	1.771	3.542	SA 105	
16	PIN	Ø140 X 825 LG.	2	95.465	190.930	SA 105	
15	PIN COLLAR	Ø300 / Ø143 X 14 LG..	2	1.771	3.542	SA 105	
14	PIN	Ø140 X 390 LG.	2	47.128	94.256	SA 105	
13	SUPPORT BRACKET	100 THK. X 350 X 830 LG.	4	228.042	912.288	SA 516 GR.70	
12	PLATE	6 THK. X 122 X 668 DEV. LG.	2	6.670	13.340	SA 516 GR.70	
11	PLATE	6 THK. X 399 X 448 LG.	4	2.346	9.384	SA 516 GR.70	
10	HOOK PLATE-III	40 THK. X 1840 X 1150 LG.	4	473.374	1893.496	SA 516 GR.70	
09	HOOK PLATE-II	45 THK. X 1230 X 4645 LG.	4	928.913	3715.652	SA 516 GR.70	
08	HOOK PLATE-I	50 THK. X 1310 X 4725 LG.	2	1080.231	2160.462	SA 516 GR.70	
07	LIFTING LUG PL.-II	32 THK. X 962 X 1120 LG.	4	98.747	394.988	SA 516 GR.70	
06	LIFTING LUG PL.-I	50 THK. X 992 X 1150 LG.	2	171.138	342.276	SA 516 GR.70	
05	BOTTOM PLATE-II	25 THK. X 870 X 4503 DEV. LG.	2	286.629	573.258	SA 516 GR.70	
04	BOTTOM PLATE-I	32 THK. X 850 X 4483 DEV. LG.	1	368.536	368.536	SA 516 GR.70	
03	TOP PLATE-II	32 THK. X 265 X 4400 LG.	2	122.620	245.240	SA 516 GR.70	
02	TOP PLATE-I	25 THK. X 850 X 4400 DEV. LG.	1	535.480	535.480	SA 516 GR.70	
01	VERTICAL PLATE	32 THK. X 836 X 4400 LG.	2	861.138	1722.276	SA 516 GR.70	

TYPE OF PRODUCT OR NAME OF CUSTOMER/PROJECT: S.O. : 7874 PROJECT : BHEL-CFFP , HARIDWAR

Bharat Heavy Electricals Ltd
UNIT: HEAVY PLATES & VESSELS PLANT
VISAKHAPATNAM - 530012

DRN: T.S.S.RAO DATE: 25.02.2019 NO. OF VAR: /
CHD: V.KAVIKUMAR DATE: 25.02.2019 /
APPD: Y.PRASANNAKUMAR DATE: 25.02.2019 /

DEPT: HT ENGG. ALL DIMENSIONS ARE IN mm SCALE: NTS WEIGHT (Kg): 15118.740 REF TO ASSY / OLD DWG: 02-34-004 ITEM NO: / NO OF ITEMS: /

TITLE: BAIL ARM CAPACITY-185T FOR RAMSHORN HOOK CARD CODE: U 01 DRAWING NO: 1-LD-001-U0011 SHEET 1 OF 2 REV: 00

REV	DATE	ALTERED
01		CHKD & APPD

DRAWING NO: 1-LD-001-U0012

ALL DIMENSIONS ARE IN MILLIMETERS

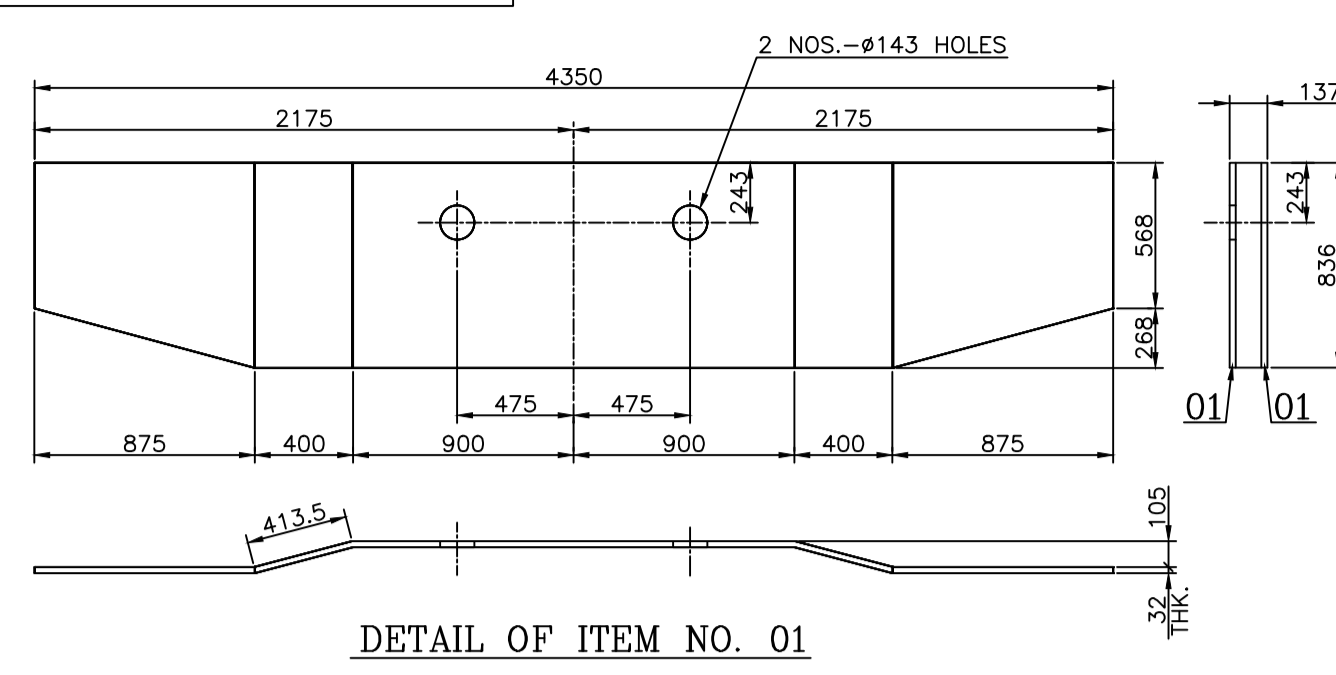

DETAIL OF ITEM NO. 01

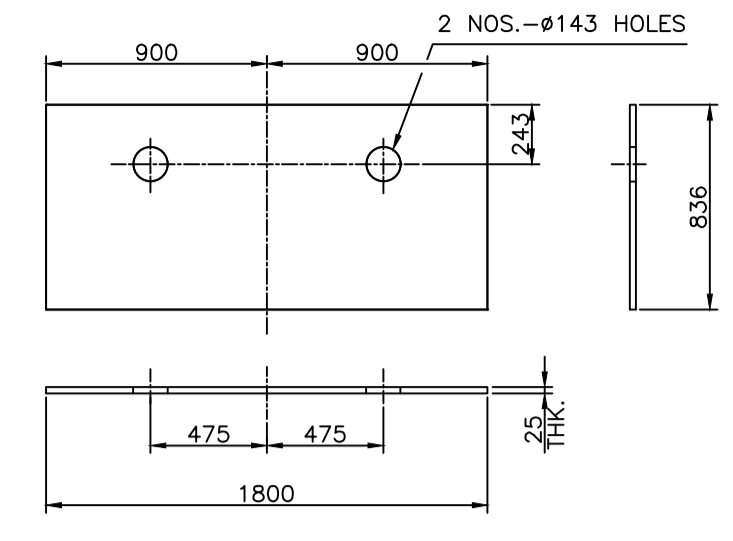

DETAIL OF ITEM NO. 36

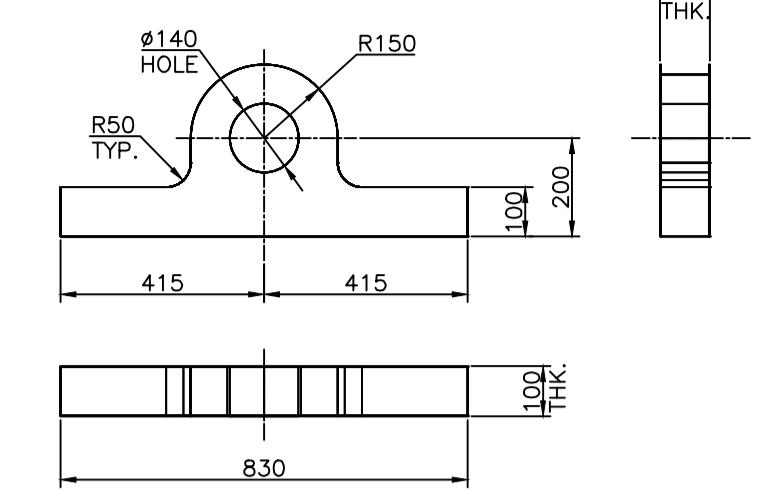

DETAIL OF ITEM NO. 13

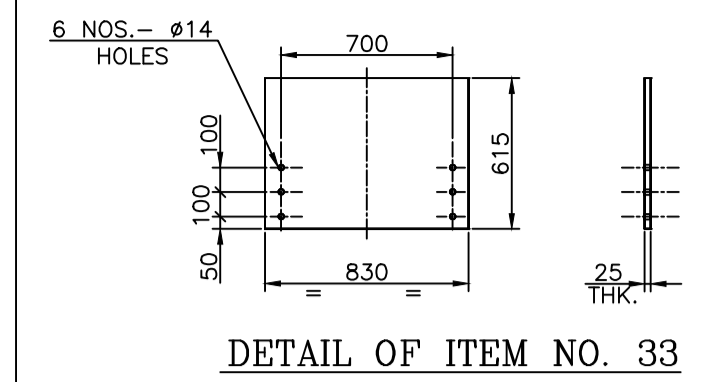

DETAIL OF ITEM NO. 33

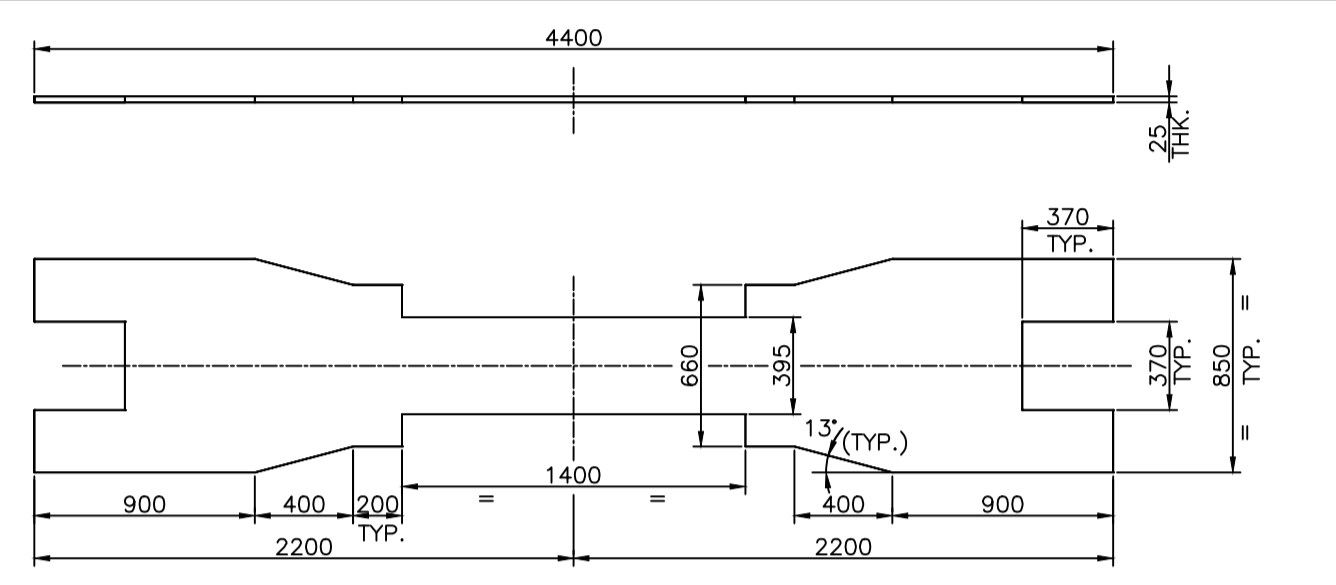

DETAIL OF ITEM NO. 02

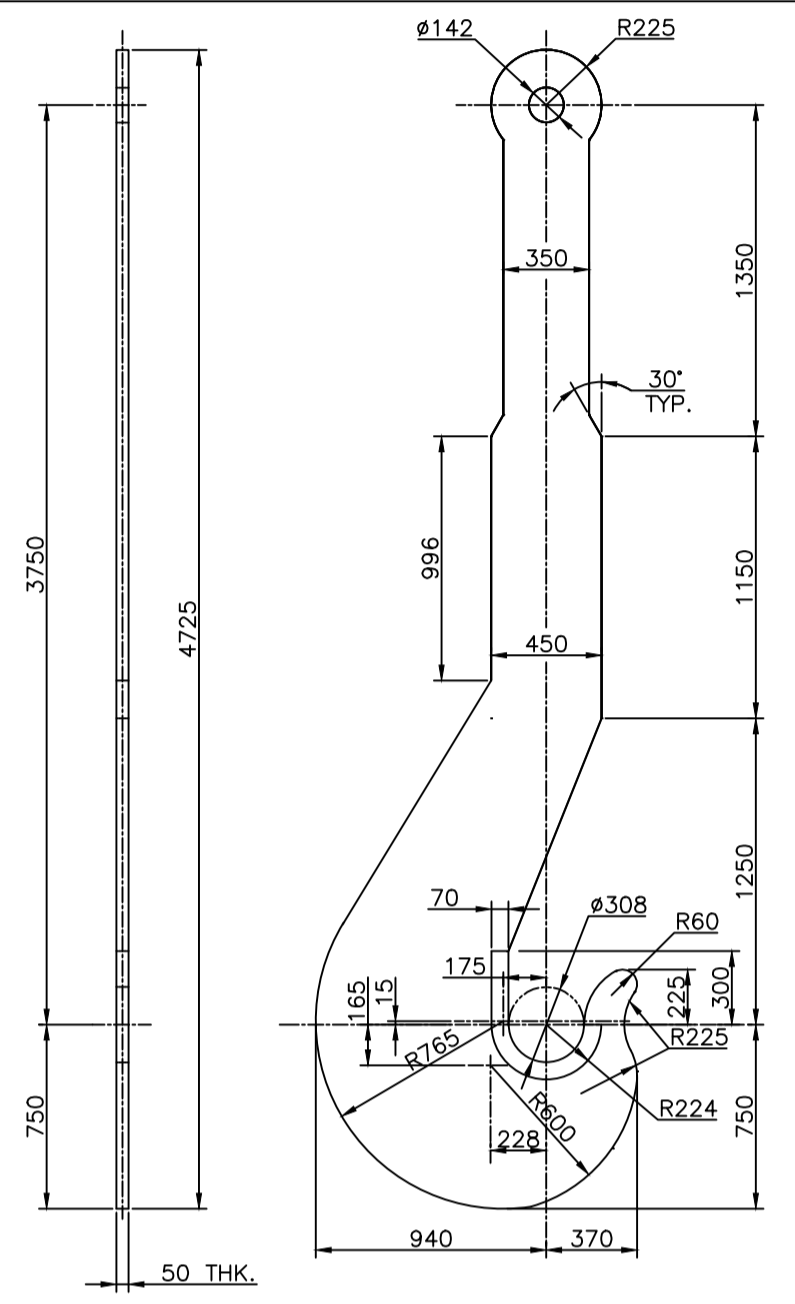

DETAIL OF ITEM NO. 08

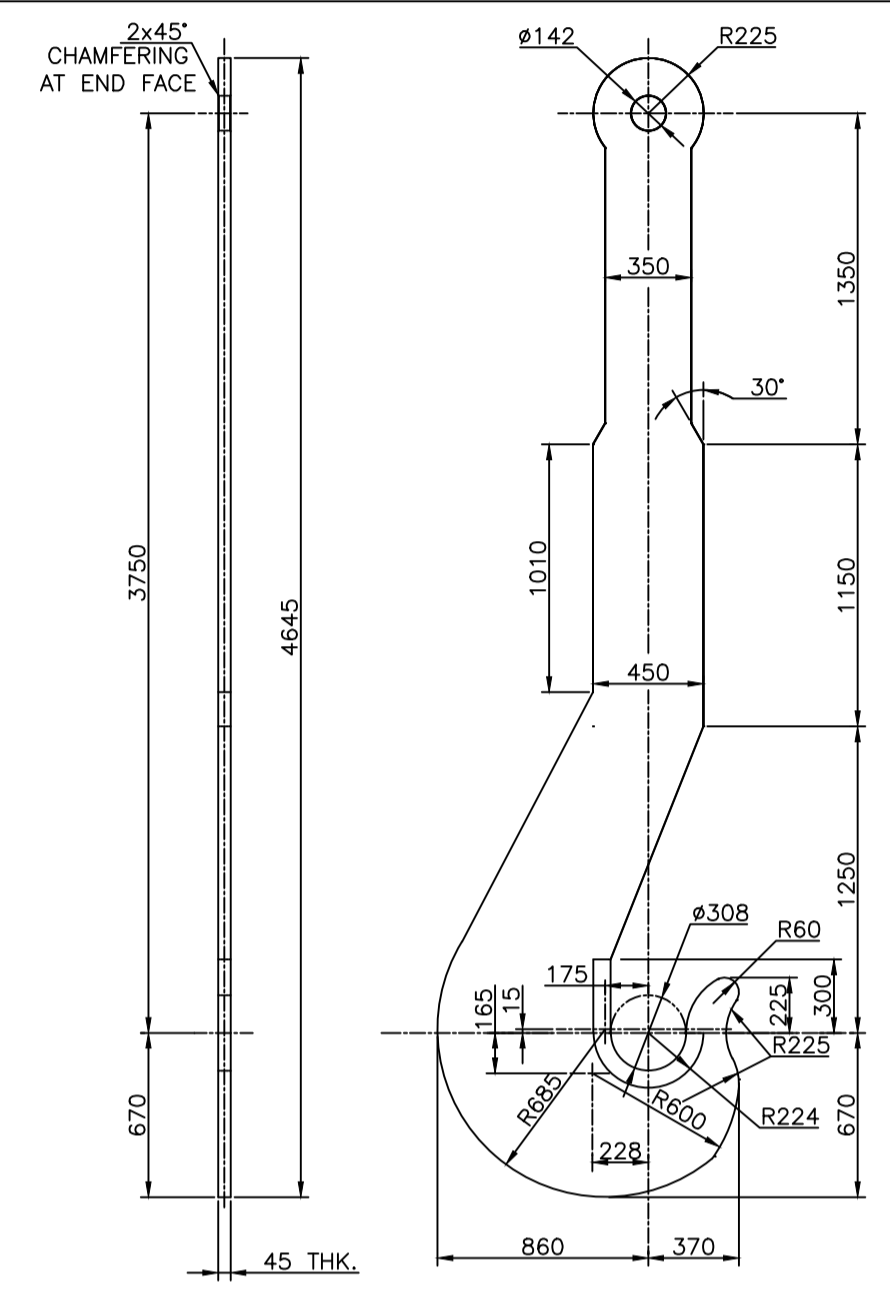

DETAIL OF ITEM NO. 09

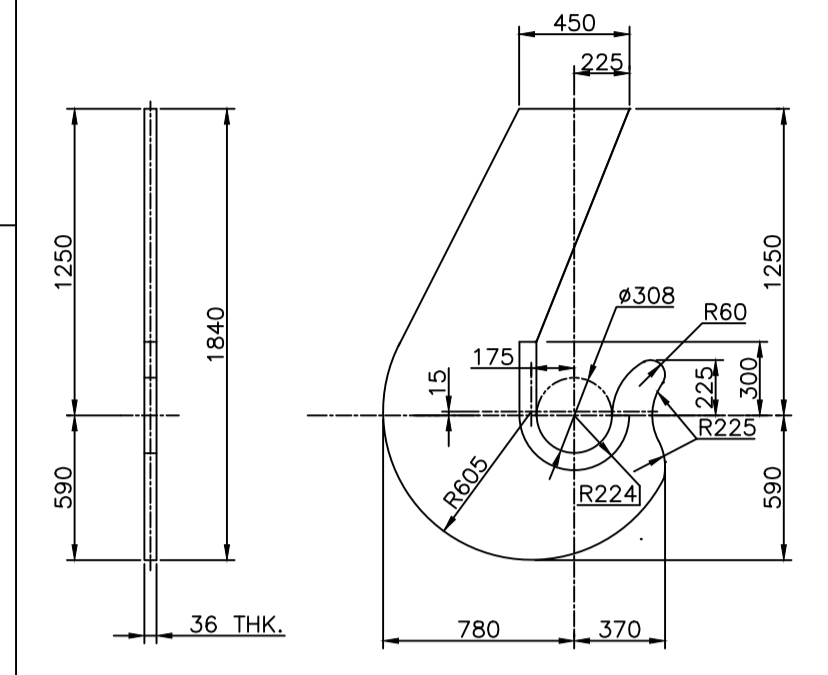

DETAIL OF ITEM NO. 10

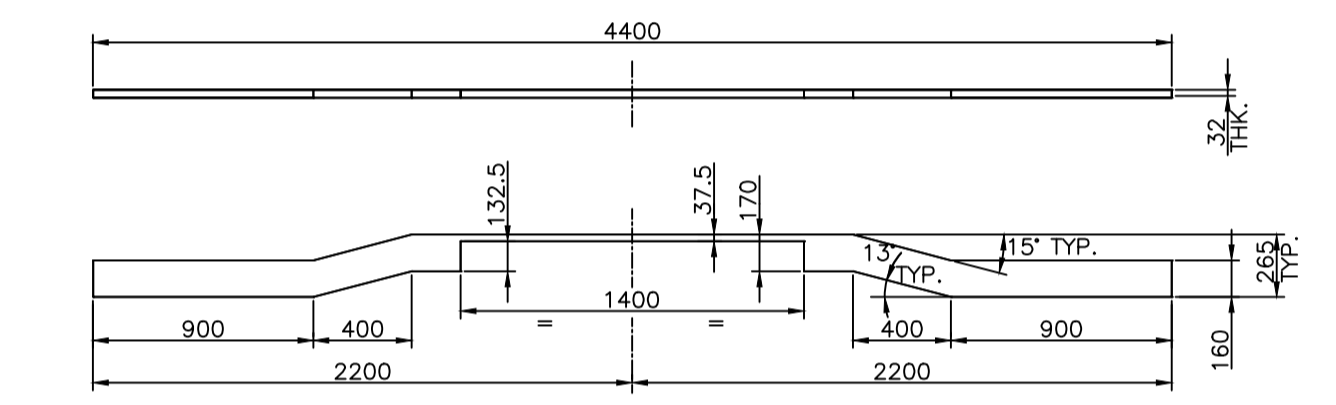

DETAIL OF ITEM NO. 03

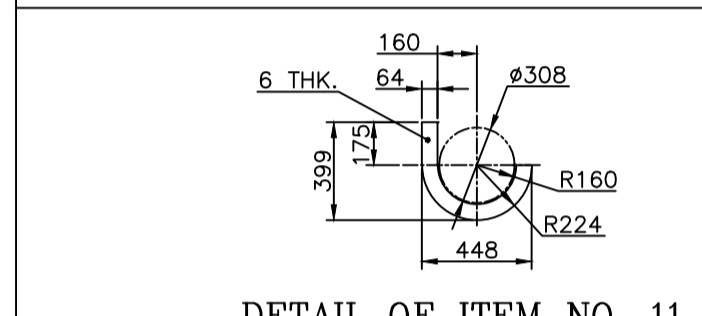

DETAIL OF ITEM NO. 11

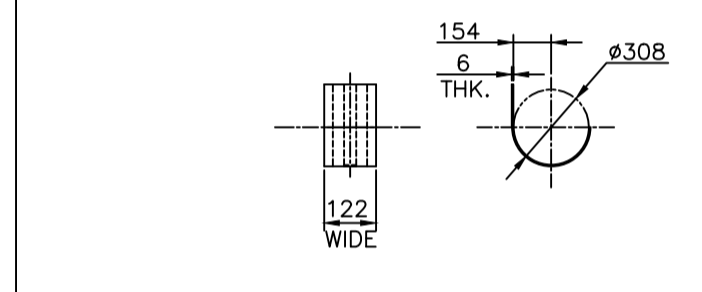

DETAIL OF ITEM NO. 12

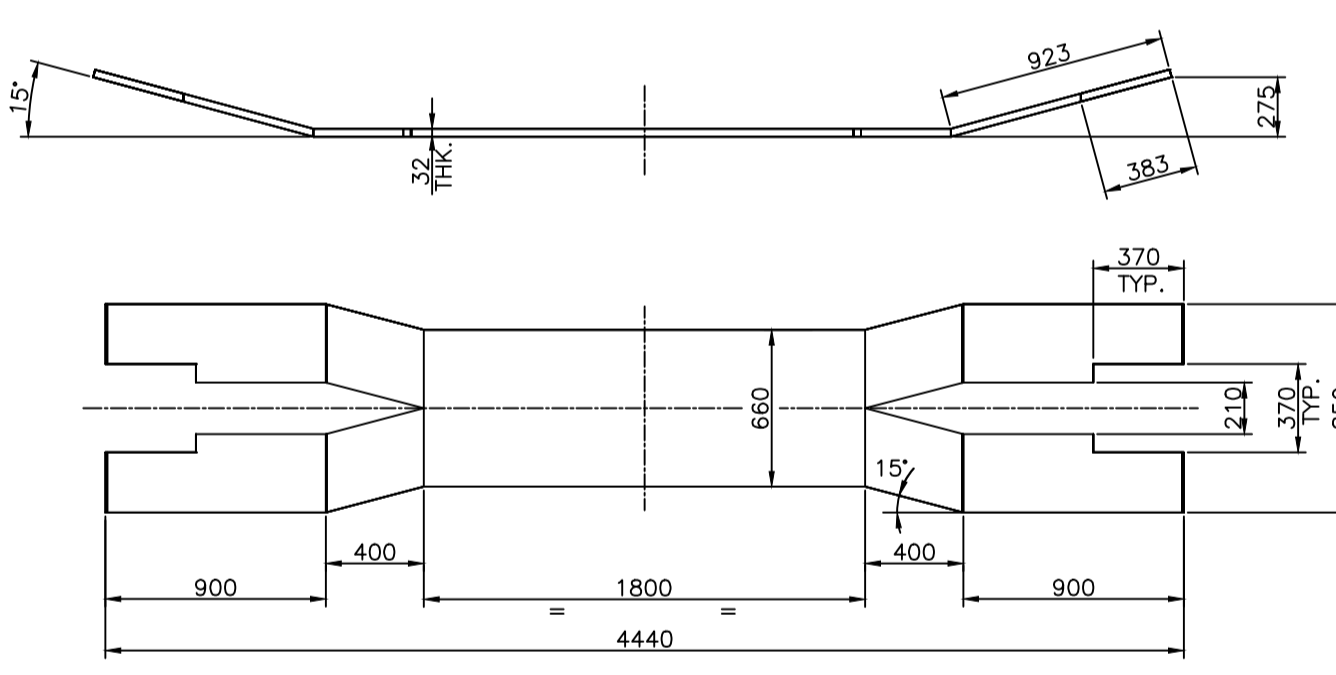

DETAIL OF ITEM NO. 04

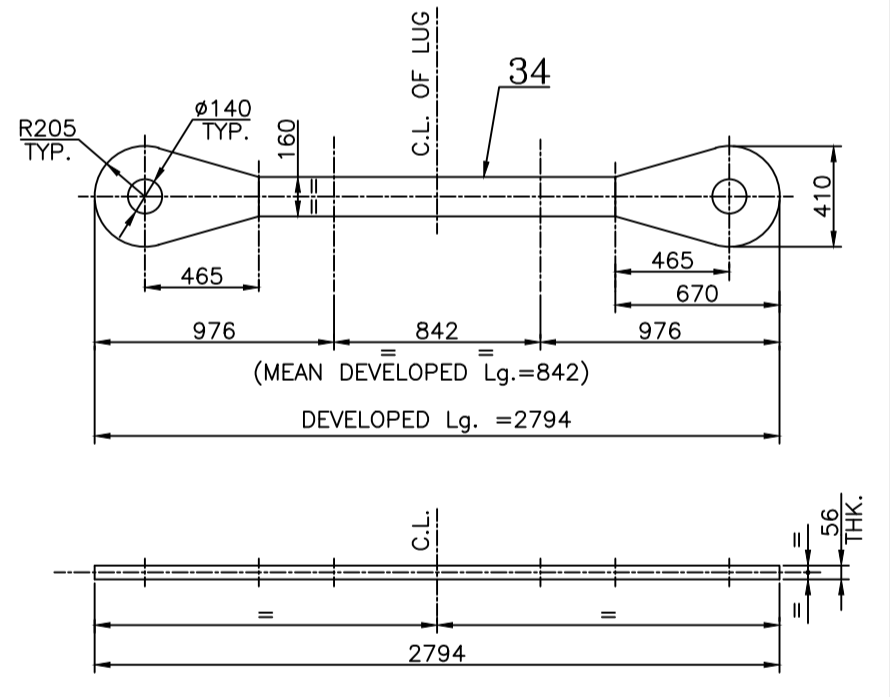

DETAIL OF ITEM NO. 34

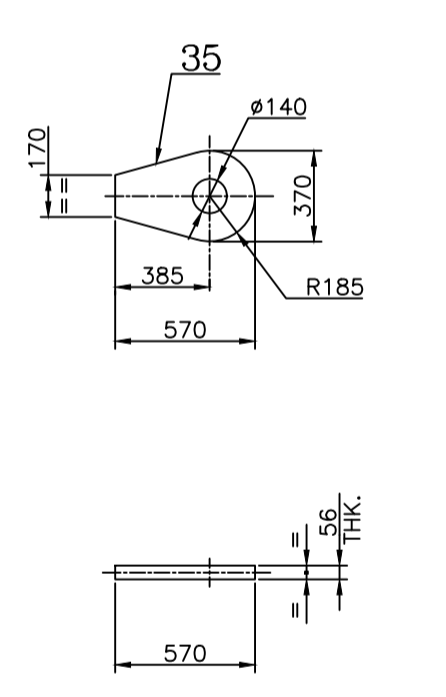

DETAIL OF ITEM NO. 35

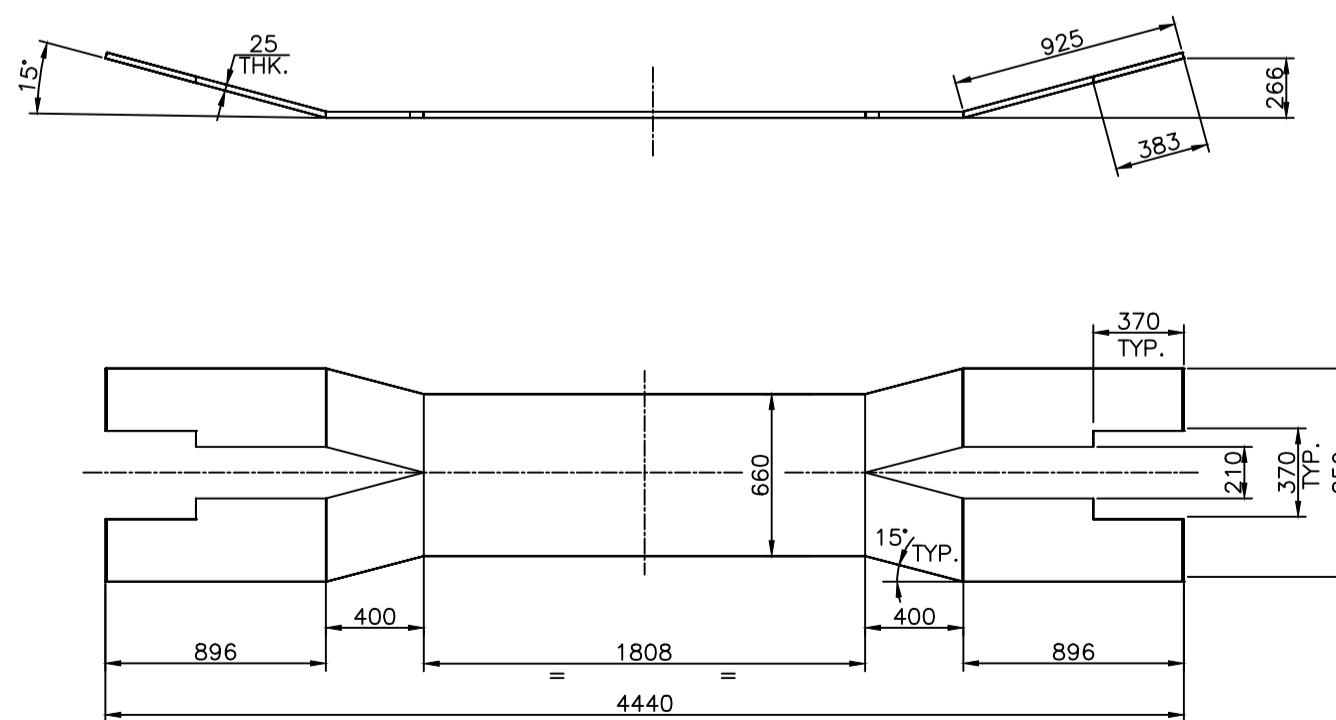

DETAIL OF ITEM NO. 05

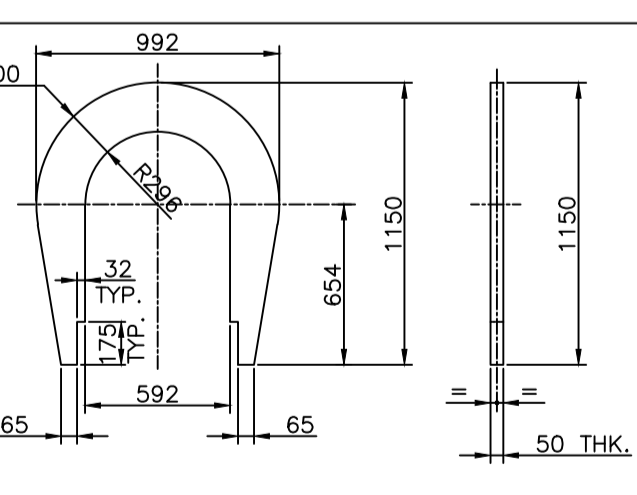

DETAIL OF ITEM NO. 06

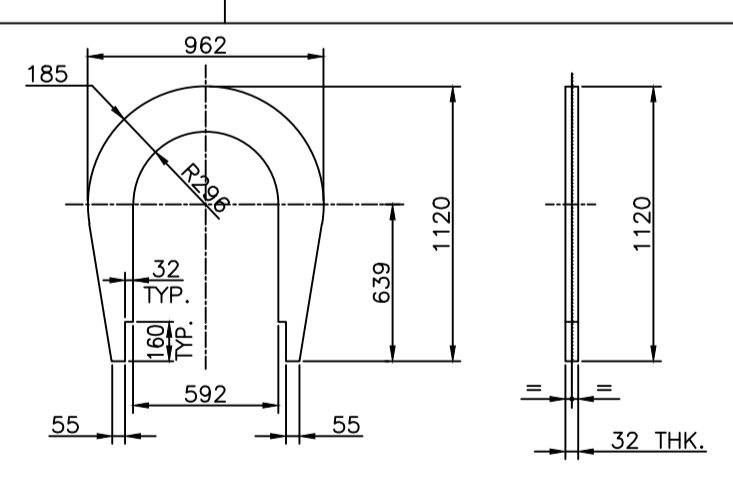

DETAIL OF ITEM NO. 07

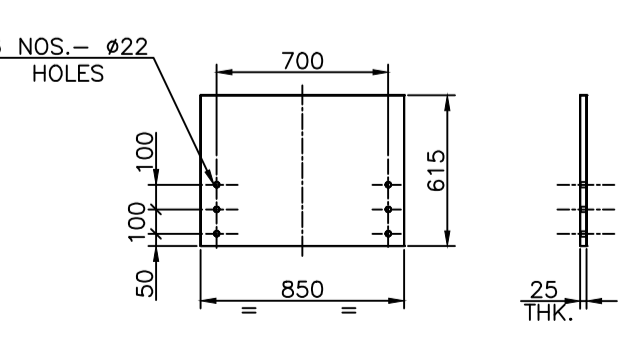

DETAIL OF ITEM NO. 18

REV	DATE	ALTERED
01		CHKD & APPD
ZONE		

TYPE OF PRODUCT OR NAME OF CUSTOMER/PROJECT				Bharat Heavy Electricals Ltd UNIT: HEAVY PLATES & VESSELS PLANT VISAKHAPATNAM - 530012	
DRN	T.S.S.RAO	DATE	25.02.2019	NO. OF VAR	/
CHD	V.KAVIKUMAR	DATE	25.02.2019	NO. OF ITEMS	/
APPD	Y.PRASANNAKUMAR	DATE	25.02.2019	REF TO ASSY / OLD DWG	02-34-004
DEPT	HT ENGG.	ALL DIMENSIONS ARE IN mm	SCALE	WEIGHT (Kg)	
CODE	320		NTS		
TITLE			BAIL ARM CAPACITY-185T FOR RAMSHORN HOOK		
DRAWING NO:			1-LD-001-U0012		
SHEET			2 OF 2		
CARD CODE			U 01		
REV			00		

CAUTION: The information on this drawing is the property of BHARAT HEAVY ELECTRICALS LTD. It must not be used directly or indirectly in any way detrimental to the interest of the company.

		MANUFACTURER'S NAME & ADDRESS BHEL-VISAKHAPATNAM		MANUFACTURING QUALITY PLAN				PROJECT: CFFP PACKAGE: 185T PO No: P8R0234 dtd 10.09.2018 SO NO:7874					
		ITEM: Bail Arm		QP NO: CQP:2481 REV 00 Date: 22.03.2019 Page 1 of 2		REFERENCE DOCUMENTS 7		ACCEPTANCE NORMS 8		FORMAT OF RECORD 9		AGENCY M C N	

SL No	COMPONENT & OPERATION	CHARACTERISTICS	CLASS	TYPE OF CHECK	QUANTUM OF CHECK	REFERENCE DOCUMENTS	ACCEPTANCE NORMS	FORMAT OF RECORD	AGENCY	REMARKS
1	2	3	4	5	6	7	8	9	M C N	

RAW MATERIALS & BOUGHT OUT ITEMS										
1.0										
1.1	SA 516 Gr.70 Plates as applicable	Chemical, Mechanical tests, Soundness (UT), Heat treatment	A	TC verification	100%	Material specification as per Column 2 UT as per ASTM A 435		Mfg TC	√	P QC
1.2	Pins: SA105	Chemical, Mechanical tests, Soundness (UT)	A	TC verification	100%	Material specification as per Column 2 UT as per SA 388 Cl 3.3.4		Mfg TC	√	P QC

INPROCESS INSPECTION										
2.0										
2.1	Welding Qualification	Procedure Qualification	B	WPS review	100%	ASME Sec IX		WPS PQR		P QC
2.2	Welder Qualification	Personnel Qualification	B	WQR review	100%	ASME/AWS		WQR		P QC
2.3	Edge preparation by gas cutting	Soundness	B	Visual & MPT	100%	BHEL Drawing		MPT Report		QC & ND
2.4	Fit up inspection	Weld angle, mismatch, root gap	B	Visual & Dimension	100%	BHEL Drawing		Report		P QC

Prepared By <i>V. Sunitha</i>	Reviewed & Approved By <i>V. Sampath Kumar</i>	Approved By <i>H. S. R.</i>
V. Sunitha	V. Sampath kumar	Customer Signature & Stamp

LEGEND: P: PERFORM TC; Test Certificate; WPS: Welding procedure specification; PQR: Procedure Qualification Record; WQR: Welder Qualification Record; AWS: American welding society; UT: Ultrasonic testing; RT: Radiographic testing; MPI: Magnetic particle Inspection; LPI: Liquid Penetrant Inspection; DFT: Dry film thickness; M: BHEL/Approved subcontractor; C: BHEL QC/ND/Authorized inspection agency; N: Customer, A: Critical; B: Major; R-Report/Record as applicable; P: Perform; V-Verification of documents for witness marked items; W: Witness
Items marked with ✓ (TICK) in column 'D', certificates shall be included in Documentation.

MANUFACTURER'S NAME & ADDRESS		MANUFACTURING QUALITY PLAN					PROJECT: CFFP PACKAGE: 185T PO No: P8R0234 dtd 10.09.2018 SO NO:7874				
BHEL-VISAKHAPATNAM		ITEM: Bail Arm					QP NO: CQP:2481 REV 00 Date: 22.03.2019 Page 2 of 2				
SL No	COMPONENT & OPERATION	CHARACTERISTICS	CLASS	TYPE OF CHECK	QUANTUM OF CHECK	REFERENCE DOCUMENTS	ACCEPTANCE NORMS	FORMAT OF RECORD	AGENCY	REMARKS	
1	2	3	4	5	6	7	8	9	M	C	N
2.5	NDE for welds	Soundness	B	DPT	100%	BHE-NDT-PT-07026		DPT report	P	ND	
2.6	All welds and back chipped areas.	Soundness	B	DPT	100%	BHE-NDT-PT-07026		DPT Report	P	ND	
2.7	Drilling of Holes as per drawing	Hole dimensions	B	Visual & Measurement	100%	As per drawing		Report	√	P	QC
2.8	Hook dimensions as per drawing	Hook profile and dimensions	B	Visual & Measurement	100%	As per drawing		Report	√	P	QC
3.0	FINAL INSPECTION & TESTING										
3.1	Visual & Dimensional check	Visual & Dimensions	B	Visual Measurement	100 %	BHEL Drawing			√	P	QC
3.2	Identification	Stamping	B	Verification	100 %	--				P	QC
3.3	Surface preparation & painting	Surface cleaning & painting	B	Paint shade, DFT Thk	100 %	BHEL Drawing / Painting spec				P	QC
3.4	Preservation & packing	Packing	B	Visual & Verify	100%	--				P	QC