

**BHARAT HEAVY ELECTRICALS LIMITED
TRANSMISSION BUSINESS GROUP
SUBCONTRACTS MANAGEMENT
SECTOR-142, EXPRESSWAY NOIDA-201305**



TENDER DOCUMENTS

FOR

**HIRING OF HV TEST KIT FOR 400KV GIS AT CHAREMA IN HIMACHAL
PRADESH**

CUSTOMER

NHPC LIMITED

TENDER SPEC. NO.: TBSM/CHAMERA/HV TEST KIT/TENDER/03

DATE: 08.06.2018

**TRANSMISSION BUSINESS GROUP
SUBCONTRACTS MANAGEMENT**

INDEX

| Sl. No. | Description | No. of Pages |
|----------------|---|---------------------|
| 1.0 | Notice Inviting Tender | 07 |
| 2.0 | Pre-Qualifying Requirements | 02 |
| 3.0 | Procedure for submission of sealed Tenders | 01 |
| 4.0 | Project Information | 01 |
| 5.0 | Scope of work | 01 |
| 6.0 | Terms & Conditions | 07 |
| 7.0 | Price Schedule (Annexure-I,II & III) | 03 |
| 8.0 | Drawings | 07 |
| 9.0 | No Deviation Certificate | 01 |
| 10.0 | Declaration for relation in BHEL | 01 |
| 11.0 | E-payment details | 01 |



BHARAT HEAVY ELECTRICALS LIMITED

TRANSMISSION BUSINESS GROUP
SECTOR-142, EXPRESSWAY NOIDA, NOIDA-201305

e-mail:-krishna.singh@bhel.in

NOTICE INVITING TENDER

REF.: TBSM/CHAMERA/HV TEST KIT/ TENDER/03

DATE: 08.06.2018

SUB: TENDER FOR "HIRING OF HV TEST KIT FOR 400KV GIS AT CHAMERA IN HIMACHAL PRADESH"

Dear Sirs,

1. Sealed tenders are invited for the following:

| NAME OF WORK | VALIDITY PERIOD | EMD | TENDER SUBMISSION DATE AND TIME | TENDER OPENING DATE & TIME |
|--|---------------------------------------|-----|---------------------------------|--|
| Hiring of HV test kit for 400kV GIS at Chamera in Himachal Pradesh | 06 months from date of tender opening | NIL | 15.06.2018 14.30 hrs. | 15.06.2018 15.30 hrs. (Technical bid only) and Price bid opening/Reverse Auction date will be intimated later to Techno commercially acceptable parties |

2. The sealed bid should be dropped in the TBSM Tender Box kept at lobby area in BHEL, TBG office located at 5th floor, Advant Navis IT Business Park, Plot No-7, Sector-142, Expressway Noida, Noida -201305 (UP). In case of bid documents are bulky and cannot be dropped in the TBSM tender box, the same can be handed over to Sh. Krishna Swaroop Singh, DGM (TBSM) or Sh. V.K.Ubnare, Manager (TBSM).
3. Offers can also be sent by courier/ registered post at the below address:

TENDER SPEC. NO.:TBSM/CHAMERA/HV TEST KIT/ TENDER/03, DATE: 08.06.2018

TO,

**KRISHNA SWAROOP SINGH
DGM (TBSM)**

**BHARAT HEAVY ELECTRICALS LIMITED,
TRANSMISSION BUSINESS GROUP,
5TH FLOOR, ADVANT NAVIS IT BUSINESS PARK,
PLOT No-7, SECTOR-142, EXPRESSWAY NOIDA,
NOIDA-201305
DISTT- G.B.NAGAR (UTTAR PRADESH)
TELEPHONE: 0120-6748454, 6748440 FAX: 0120-6748579
E-mail: tbsm@bhel.in**

4. The prospective bidders who have downloaded the tender documents from our website are requested to send their acknowledgement and willingness to participate in the tender to the undersigned, through fax or email.
5. Offers should be strictly in accordance with the Tender Specifications and General Instructions to Tenderer enclosed herewith.
6. "BHEL reserves the right to go for Reverse Auction (RA) (Guidelines as available on www.bhel.com) instead of opening the sealed envelope price bid, submitted by the bidder. This will be decided after techno-commercial evaluation. Bidders to give their acceptance with the offer for participation in RA. Non-acceptance to participate in RA may result in non-consideration of their bids, in case BHEL decides to go for RA.

Those bidders who have given their acceptance to participate in Reverse Auction will have to necessarily submit 'Process compliance form' (to the designated service provider) as well as 'Online sealed bid' in the Reverse Auction. Non-submission of 'Process compliance form' or 'Online sealed bid' by the agreed bidder(s) will be considered as tampering of the tender process and will invite action by BHEL as per extant guidelines for suspension of business dealings with suppliers/ contractors (as available on www.bhel.com).

The bidders have to necessarily submit online sealed bid less than or equal to their envelope sealed price bid already submitted to BHEL along with the offer. **The envelope sealed price bid of successful L1 bidder in RA, if conducted, shall also be opened after RA and the order will be placed on lower of the two bids (RA closing price & envelope sealed price) thus obtained. The bidder having submitted this offer specifically agrees to this condition and undertakes to execute the contract on thus awarded rates.**

If it is found that L1 bidder has quoted higher in online sealed bid in comparison to envelope sealed bid for any item(s), the bidder will be issued a warning letter to this effect. However, if the same bidder again defaults on this count in any subsequent tender in the unit, it will be considered as fraud and will invite action by BHEL as per extant guidelines for suspension of business dealings with suppliers/ contractors (as available on www.bhel.com).

7. All documents submitted with the offer shall be signed and stamped in each page by authorized representative of the bidder.
 8. Clarifications, if any, can be obtained from the undersigned but such requests should be submitted well before the due date for submission of tenders. Due date for submission and opening of tenders will not be extended on such grounds.
 9. The offers of the bidders who are under suspension as also the offers of the bidders, who engage the services of the banned firms, shall be rejected. The list of banned firms is available on BHEL web site www.bhel.com.
- 1.0 Integrity commitment, performance of the contract and punitive action thereof:
 - 1.1. Commitment by BHEL:

BHEL commits to take all measures necessary to prevent corruption in connection with the tender process and execution of the contract. BHEL will during the tender process treat all Bidder(s) in a transparent and fair manner, and with equity.
 - 1.2. Commitment by Bidder/ Supplier/ Contractor:
 - 1.2.1. The bidder/ supplier/ contractor commit to take all measures to prevent corruption and will not directly or indirectly influence any decision or benefit which he is not legally entitled to nor will act or omit in any manner which tantamount to an offence punishable under any provision of the Indian Penal Code, 1860 or any other law in force in India.

- 1.2.2. The bidder/ supplier/ contractor will, when presenting his bid, disclose any and all payments he has made, and is committed to or intends to make to agents, brokers or any other intermediaries in connection with the award of the contract and shall adhere to relevant guidelines issued from time to time by Govt. of India/ BHEL.
- 1.2.3. The bidder/ supplier/ contractor will perform/ execute the contract as per the contract terms & conditions and will not default without any reasonable cause, which causes loss of business/ money/ reputation, to BHEL.

If any bidder/ supplier/ contractor during pre-tendering/ tendering/ post tendering/ award/ execution/ post-execution stage indulges in mal-practices, cheating, bribery, fraud or and other misconduct or formation of cartel so as to influence the bidding process or influence the price or acts or omits in any manner which tantamount to an offence punishable under any provision of the Indian Penal Code, 1860 or any other law in force in India, then, action may be taken against such bidder/ supplier/ contractor as per extant guidelines of the company available on [www. bhel.com](http://www.bhel.com) and/or under applicable legal provisions”.

10. Also, offer of the bidders who are suspended (under hold/ delist) for business dealings by BHEL, TBG shall not be considered. Please note that lifting/ restoration of suspension (Ban/Hold/ De-list) of business dealing is not automatic after expiry of specified suspension period. Hence, vendor shall be considered as suspended for business till suspension is lifted by BHEL in writing on specific request of the vendor as per extant guidelines.
11. BHEL Fraud Prevention Policy, "The Bidder along with its associate/ collaborators/ sub-contractors/ sub-vendors/ consultants/ service providers shall strictly adhere to BHEL Fraud Prevention Policy displayed on BHEL website <http://www.bhel.com> and shall immediately bring to the notice of BHEL Management about any fraud or suspected fraud as soon as it comes to their notice."
12. Technical Bid will be opened in the office of undersigned. If required, technical discussions will be held with only those bidders who have taken any deviations. Bidders representative may be present during technical bid opening for technical discussion, if required. The price bids will be opened subsequently, after Technical Bids of all the bidders have been evaluated and frozen. Bidders should quote their most competitive rates as there will not be any price negotiation. However if felt necessary by BHEL, price negotiation will be held with lowest bidder (L-1) only. IT WOULD BE PREFERRED THAT YOUR OFFER IS WITHOUT ANY DEVIATION w.r.t. TENDER SPECIFICATIONS AND THE SAME MAY BE CLEARLY MENTIONED ON THE COVERING LETTER ACCOMPANYING THE TECHNICAL BID. Offers with deviations are likely to be rejected. However if the bidder insists on any technical or commercial deviations, from the specification and/or tender conditions, the price implication if any, of withdrawing the deviations must be submitted along with the price bid in a separate sealed envelope superscribed "Price Implication for withdrawal of deviations".
13. Offers will be scrutinized based on the qualifying requirements and only those who are technically and financially capable to execute the Job and who fulfil the Pre-Qualifying Requirements (PQR) are eligible to quote against the above NIT. Decision of BHEL/Customer shall be final and binding on the bidder.
14. In case any adverse information is received concerning performance, capability or conduct of the bidder after issue of tender enquiry, BHEL reserves the right to reject the offer at any stage as deemed fit.
15. The purchase preference for central P.S.Us shall be given as per the prevailing Government policy.

16. In case an offer is not being submitted by the prospective bidders against this tender, they may send their "regret" letter to this office, for information.
17. Details of qualifying work(s) executed by the bidder will be forwarded to the principal employer for verification of the work with respect to completion, commencement & completion date and value of the work executed. Performance feedback of the bidder will also be sought from the principal employer.
18. The bidder representative may be called for discussion with the committee. His originals may be verified by the committee. In addition to above their organisation chart and detail list of manpower, tools & plants and technical capability will be discussed and ascertained by the committee.

Thanking you,

Yours faithfully,
For and on behalf of BHEL,

(Krishna Swaroop Singh)
DGM /TBSM

TO BE FILLED BY TENDERER

Certified that General Instructions and Information for tenderer have been read/ complied/ agreed to and each page of tender offer has been initialled and stamped.

(Signature of Tenderer)

Name and Designation of Authorised person (s)
Signing the tender on behalf of the tenderer

Authorization of representative who will participate in the on line Reverse Auction Process:

| | | |
|---|---|--|
| 1 | NAME & DESIGNATION OF OFFICIAL | |
| 2 | POSTAL ADDRESS (COMPLETE) | |
| 3 | TELEPHONE NOS. (LAND LINE & MOBILE BOTH) | |
| 4 | FAX NO. | |
| 5 | E-MAIL ADDRESS | |
| 6 | NAME OF PLACE / STATE / COUNTRY, WHEREFROM S/HE WILL PARTICIPATE IN THE REVERSE AUCTION | |

BHARAT HEAVY ELECTRICALS LIMITED
TRANSMISSION BUSINESS GROUP, NOIDA

PRE-QUALIFYING REQUIREMENTS

Tender Ref. No.: TBSM/CHAMERA/HV TEST KIT/ TENDER/03

Date: 08.06.2018

SUB: TENDER FOR HIRING OF HV TEST KIT FOR 400KV GIS AT CHAMERA IN HIMACHAL PRADESH.

Only those bidders who are technically and financially capable to execute the Job and who fulfil the Pre-Qualifying Requirements [PQR] given under are eligible to quote against the above NIT. Tenderers should submit their offer along with credentials in a sealed envelope as per the procedure specified in tender documents.

The PQR for subject tender shall be as under:

| Sl. No. | Criteria | Description |
|---------|-----------------------|--|
| A | Turn Over | Vendors should have a minimum average annual turnover of Rs. 9 Lacs for last three fin. Years (2014-15, 2015-16 & 2016-17 OR 2015-16, 2016-17 & 2017-18) and should submit audited balance sheet and Profit & Loss Account Sheet of these years. In case audited balance sheet is not available due to turnover being less than statutory requirement of audit, bidder should furnish self-certified copies of Balance Sheet, Profit & Loss account along with income tax returns and form 26AS of these years. |
| B | Profit | Vendor should have earned profit in at least one year during last three financial years as mentioned in A above. |
| C | Technical Requirement | The bidder should have following experience during last seven year ending on 30.04.2017: 1. The Bidder shall have experience of conducting HV Testing of 400kV GIS at Site for at least 1 GIS Project. 2. The bidder shall have its own HV Test Kit OR can use a leased one. In case of a leased HV Test Kit, the bidder shall submit an authorization certificate from the owner of the HV Test Kit. |

NOTES:

1. In order to technically qualify in this tender, bidder should meet all criteria i.e. A, B & C mentioned above.
2. The bidder shall submit the Contract Agreement/ Work Order/LOI and performance/ completion/ execution certificate/ test report issued by Customer/ Contractor along with technical bid in support of qualification.

3. Consortium/ JV bidding is not allowed.
4. BHEL reserves the right to:
 - (a) Accept or reject any bid received at its discretion without assigning any reasons whatsoever.
 - (b) Postpone the above mentioned date, split and distribute the work among more than one bidder without assigning any reason whatsoever.
 - (c) May ask for further qualification during techno commercial scrutiny of bids received.
 - (d) May ask for further proofs including TDS certificates/ Final bill/Form 26AS/ payment detail for the said job for cross- verification.
5. BHEL shall not be responsible for any delay, loss, damage for bids sent by post.
6. BHEL shall not be liable for any expenses incurred by bidder in preparation of bid irrespective of whether it is accepted or not.
7. Quotations received from bidders who do not fulfil the PQR shall be summarily rejected without any further evaluation and information to bidders.
8. Canvassing i.e. soliciting favour, seeking advantage etc. in any form is strictly prohibited and any bidder found to have engaged in canvassing shall be liable to have his bid rejected summarily.
9. If the bidder deliberately gives any wrong information in his tender to create in circumstances for the acceptance to his bid, BHEL reserves the right to reject such application.
10. Bidder's selection is subject to approval of BHEL's customer (if applicable) for this work.
11. All corrigenda, addenda, amendments and clarifications to this Tender will be hosted in web page, www.bhel.com and not in the newspaper. Bidders shall keep themselves updated with all such amendments.

PROCEDURE FOR SUBMISSION OF SEALED TENDERS AND
DOCUMENT TO BE ENCLOSED WITH THE OFFER

The tenderer must submit their tenders as required in two parts in separate sealed covers prominently superscribed as Part-I, Technical Bid Part-II, Price bid and also indicating on each of the covers the tender specification number and due date and time as mentioned in the tender enquiry.

These two separate covers I and II (Part – I and Part-II) shall together be enclosed in third envelope (Cover-III) and this sealed cover shall be superscribed and submitted.

PART-I (TECHNICAL BID) COVER-I:

The following documents shall be kept in technical bid envelope:

- 1) Your covering letter for submission of offer.
- 2) Complete set of tender documents duly signed on each page including unpriced 'BOQ cum price schedule', as your acceptance of the tender conditions & NIT in toto.
- 3) Documents related to credentials as mentioned below under "important note"

PART-II (PRICE BID) COVER – II:

Rate / Price schedule only shall be given in this part-II. This envelope should be superscribed as Part-II, "Price Bid".

IMPORTANT NOTE:

Following documents must be enclosed along with other documents in technical bid envelope.

- 1) Service tax registration certificate
- 2) PAN & Copy of IT returns filed with IT authority (letter).
- 3) List & Details of similar works executed and under execution (As per PQR)
- 4) Audited Balance sheets for last three years (As per PQR).
- 5) Any other documents as per PQR and NIT

Offers without the above documents are liable to be rejected as "Techno Commercially Non Complying Offers."

PROJECT INFORMATION

1.0 CUSTOMER:

NHPC LIMITED

2.0 PROJECT LOCATION AND DETAILS:

400KV GIS AT CHAMERA IN HIMACHAL PRADESH

3.0 CONTACT PERSON: FOR CONTRACTUAL ISSUES

KRISHNA SWAROOP SINGH,
DGM (TBSM)
SUBCONTRACTS MANAGEMENT,
TRANSMISSION BUSINESS GROUP,
5TH FLOOR, ADVANT NAVIS IT BUSINESS PARK,
PLOT No-7, SECTOR-142, EXPRESSWAY NOIDA,
NOIDA-201305
DISTT- G.B.NAGAR (UTTAR PRADESH)

PHONE: 0120-6748454

E-mail: krishna.singh@bhel.in

4.0 CONTACT PERSON: FOR ENGINEERING ISSUES

VYOM
ENGINEER (TBEM)
TRANSMISSION BUSINESS GROUP,
5TH FLOOR, ADVANT NAVIS IT BUSINESS PARK,
PLOT No-7, SECTOR-142, EXPRESSWAY NOIDA,
NOIDA-201305
DISTT- G.B.NAGAR (UTTAR PRADESH)

PHONE: 0120-6748522

E-mail: vyom@bhel.in

5.0 CONTACT PERSON: FOR CONTRACT EXECUTION ISSUES

PUNEET RANA
SR.ENGINEER (SITE INCHARGE)
CHAMERA SITE
BHEL, TRANSMISSION BUSINESS GROUP

PHONE: 9971785858

E-mail: chamera.bhelqis@gmail.com

SCOPE OF WORK

| | |
|----|---|
| 1 | The HV Test Kit shall have valid calibration certificate applicable during the testing period. The HV Test kit shall be used to carry out HV Test on 400kV GIS as per relevant clause of the latest version of IEC. |
| 2 | The T&P (Tools and Plants) required at Site for carrying out shifting , storage and erection of HV Test Kit shall be arranged by BHEL (Like Trolley, Crane, Wagons, Scaffolding with Clamps, Manlift etc) . A list of TnP is to be provided by the bidder along with their offer which may be required during the testing. |
| 3 | The charges of lodging , boarding and commutation charges of the Testing Engineer/Operator is deemed to be included in the cost of deputation of Testing Engineer/Operator at S.No. 2 of BOQ. |
| 4 | Loading / Unloading, handling, shifting to & from stores, proper storage, assembly, installation shall be arranged by BHEL and shall be done in the supervision of the deputed operator/testing engineer of the BIDDER. |
| 5 | The rental of the HV Test Kit shall be applicable for the number of Kit functional days. In case of break-down/malfunctioning of the HV Test kit or non availability of the BIDDER's operator/testing engineer or BOTH , the day will not be counted as Equipment Functional Days. |
| 6 | The service charges of the Operator/Testing Engineer shall be applicable for the number availability days of the BIDDERS Operator/Technician. In case of break-down/malfunctioning of the HV Test kit or non availability of the BIDDER's operator/testing engineer or BOTH , the day will not be counted as Operators/Testing Engineer availability day. |
| 7 | If during the hiring period of the services of the BIDDER , the HV Test and the operator are idle due to the unavailability of the work front at the Site due to national holiday, site requirement, inaction of BHEL or its onsite contractor leading to idling of the Test Kit and the Operator the Idling charges shall be admissible as per S.No. 3 of BOQ |
| 8 | In case of damage to the HV Test Kit caused due to its operation , the bidder will have to arrange for its repair at its own cost without any additional price implication to BHEL . The BIDDER shall have to arrange for Insurance to cover the Risk Associated in transportation and use at Site. |
| 9 | Studies , drawings, models and documents communicated to the BIDDER shall be used exclusively for the execution of the Contract. The BIDDER shall treat these documents and Test Reports as confidential and they shall not be distributed , published or generally communicated to any third party/parties without prior express permission in writing by BHEL. |
| 10 | The BIDDER shall also inform in their offer about the tentative dimension of the HV Test Kit and the area required for its storage at Site. Any Special connector/cable/ accessories/consumable required in setting up the test circuit shall be arranged by the Bidder. |
| 11 | If the HV Test Kit is required for extended period , per day charges shall be applicable for any such extension. The rates shall be applicable for 6 months and can be used for redeployment of the HV Test Kit. |
| 12 | The payment of the Bidder shall be released only after producing the work completion Certificate issued by the BHEL Site personnel. |
| 13 | Technical Requirement of HV Test Kit 1. Minimum capability of Insulating Voltage (between Phase to Phase & Phase to Earth) : 520kV. 2. Capacitive Current : 1 Amp. |

TERMS & CONDITIONS

1.0 Earnest Monet Deposit

Not applicable

2.0 Security Deposit

Not applicable

3.0 Responsibility of vendor:

- (i) Vendor has to submit details of test equipment to be used (Make and Model Number), valid calibration certificate and user's manual before dispatch of HV test kit
- (ii) The vendor has to submit the calibration certificate of the HV test kit through OEM / NABL accredited/ Reputed laboratory only.
- (iii) For supervision of HV testing highly skilled and experienced engineer/operator should be deputed.
- (iv) The lodging, boarding and local transport of the Testing Engineer/Operator shall be in scope of vendor and charges on account of these are deemed to be included in the quoted price.
- (v) Loading/ unloading at vendors works shall be in scope of vendor.
- (vi) The vendor has to submit the detail test report with analysis immediately after testing carried out.
- (vii) The vendor has to inform the weight & dimension of HV test kit, storage space and tools required for loading/unloading required for HV test kit, facilities, manpower support etc. required to carry out the test.
- (viii) Route survey (if required) before transportation of test kit to site shall be in scope of vendor.
- (ix) For testing FQP as per OEM of test kit shall be followed.
- (x) All safety norms applicable for conducting HV test to be followed.
- (xi) The vendor shall comply with all statutory requirement applicable in connection with this test.
- (xii) During operation, if test kit or its component is found defective and it is required to be replaced/ repaired, then the vendor has to repair the test kit or shall arrange alternate HV test kit within 15 days from occurrence of such incident. No claim on account of this shall be entertained by BHEL.
- (xiii) If test could not be performed due reason solely attributable to the vendor, no idling charges shall be paid.

4.0 Responsibility of BHEL

- (i) Sufficient storage space for HV test kit shall be provided by BHEL.
- (ii) Loading / Unloading at site, handling, shifting to & from stores, proper storage, assembly, installation shall be facilitated by BHEL and shall be done in the supervision of the deputed operator/testing engineer of the vendor.
- (iii) The T&P (Tools and Plants) required at Site for carrying out shifting , storage and erection of HV Test Kit shall be arranged by BHEL (Like Trolley, Crane, Wagons, Scaffolding with Clamps, Manlift etc.). A list of T&P is to be provided by the bidder along with their offer which may be required during the testing.
- (iv) Manpower assistance (skilled / semi-skilled workmen) shall be provided by BHEL to carry out the test.
- (v) Adequate power supply required for the HV test kit will be provided by BHEL.
- (vi) BHEL at site shall arrange all necessary permit and clearance from customer/ statutory authority to perform the test.
- (vii) Assistance in obtaining road permit for Himachal Pradesh through customer.

5.0 TAXES & DUTIES:

1. All taxes (except GST) , duties , charges , royalties, cess and any other levies by Central/ State/local authorities for the execution of the contract shall be borne by the contractor and shall not be payable extra . Any increase of the same at any stage during execution of the contract shall be borne by the contractor .Quoted price of the same shall be inclusive of all such requirements.
2. Contractors have to make their own arrangement at their cost for completing the formalities, if required with relevant taxation authorities, for bringing their material, plant and machinery at site for the execution of the contract. Road permits / way bill, if required shall be arranged by the contractor.
3. The Contractor is responsible to furnish documentary evidence towards GST Registration of the State wherein the site is located or any other documents as per GST Act which may be required from time to time. BHEL will not be held to be responsible for any non-compliance of the Contractor in respect of GST laws as framed from time to time.
4. Goods and Service Tax (GST) will be reimbursed to the Contractor subject to the following conditions :-
 - (i) Submission of valid GST Compliant Tax Invoice as per the GST Invoice Rules.
 - (ii) The Invoice raised by the Contractor should indicate the BHEL GST Registration Number.
5. The GST amount shall get reflected within prescribed time limit in the GSTN for BHEL to avail the input credit. If the GST Credit is reversed/ denied/ delayed to BHEL due to non-receipt/delayed receipt of Services and/or tax invoice or due to expiry of timeline prescribed in GST law or due to any other factor for availing such Input Tax Credit (ITC) or for any other reason arising out of the act directly attributable to the Contractor,

GST amount shall be recoverable from Contractor from any dues payable to the Contractor along with any interest levied/ leviable on BHEL.

6. Statutory variation, if any, on account of GST will be payable by BHEL at actuals on submission of documentary evidence.
7. TDS under Income Tax Act/ GST Act shall be deducted as per applicable rates unless Exemption certificate, if applicable, from the appropriate Authority is furnished to BHEL along with the Invoice.
8. **New Taxes & duties (Introduced after tender opening date):**
If any new tax or duty is levied by the Central/State Government/Municipality/Local Authority and becomes directly applicable on items specified in the Bill of Quantities, full reimbursement shall be made subject to submission of documentation as per statute.

6.0 Payment terms:

- (i) No mobilisation advance shall be paid.
- (ii) 100% payment shall be paid against invoice on certification of work completion by site in-charge and on submission of following:
 - Test reports duly signed with BHEL/ Customer
 - Attendance/ time sheet jointly signed by BHEL and vendor
 -
- (iii) Payment will be released within thirty (30) days from the date of receipt of clear invoice from the vendor and on submission of documents mentioned at sl. no. 6. (ii). In case of any delay in payment due to any reason, BHEL shall not pay any interest on delayed payment.

7.0 Secrecy/ Confidentiality:

Drawings, models and other documents communicated to the vendor and test report/data shall be used exclusively for the execution of the contract and shall remain property of BHEL. The vendor shall treat these documents as confidential and these documents shall not be disclosed, distributed, published or communicated to any third party/parties without prior express permission in writing by BHEL.

8.0 Insurance:

The vendor shall arrange necessary insurance cover with appropriate Third Party Liability cover for the HV Test kit and WC/Personal Accident Policy as applicable for his testing engineers/ operator.

BHEL will not be responsible for any damage or accident directly or indirectly to the property or equipment or engineers/operator of the vendor during transportation and operation at site. Vendor shall arrange for necessary insurance to cover the risk associated in transportation and operation at Site.

BHEL/Client has obtained Insurance Policy for the plant under installation and other assets of BHEL. Accidental loss/damage to these materials will be covered under this policy.

9.0 Quantity Variations:

The quantities indicated in "Bill of Quantity" attached with the tender are indicative only and individual quantity may vary up to any extent. However, agreed unit rates shall remain firm up to a variation of + 30% of the total value of contract irrespective of variations in the quantity of individual items.

10.0 Validity of offer prices and variation:

The quoted/ finalised rates shall be firm and valid for six months from latest date of tender opening.

During execution if it is felt that, services are required for additional days then same per day hiring/ deputation/ idling charges shall be applicable for additional period. For any multiple deployment within the validity period, individual item rates shall remain same.

11.0 Zero Date and Mobilisation:

The HV test kit along with testing engineer should be deployed at site on a mutually agreed date but not later than 1 month from date of intimation of readiness of site. BHEL shall intimate in writing the readiness of site to the vendor. The testing will be witnessed by customer or BHEL representatives (as the case may be) and endorsement of the results will have to be taken from them.

12.0 Liquidated Damage:

Liquidated damage @ 0.5% (half percent) of the contract value, per calendar week, subject to ceiling of 10% of the contract value will be imposed on the vendor if the vendor fails to:

1. Mobilize test equipment or test engineer within the time specified in NIT.
2. Replace/ repair the test equipment within the time specified in NIT
3. Conduct HV test as per BHEL engineer instructions after readiness of site/ GIS for testing.

Amended/ revised contract value (excluding ORC, Extra work, Supplementary/Additional Items and PVC) shall be considered for calculating LD/ penalty.

13.0 Subletting

Subletting of the job is not allowed.

14.0 Rights of BHEL:

- (i) BHEL reserves the right to terminate the contract or get any part of the work done through other agency or deploy BHEL's own/hired/otherwise arranged resources, at the risk and cost of the vendor after due notice of a period of two weeks by BHEL, in the event of:-
 - a) Vendor fails to provide HV test kit with in notice of 30 days or mutual agreed date whichever is earlier.
 - b) Insolvency of the vendor
 - c) Poor quality of work
 - d) Corrupt or illegal act of the Contractor
 - e) Persistent disregard to the instructions of BHEL
 - f) Non fulfilment of any contractual obligations
- (ii) To meet the expenses including BHEL overheads on the differential cost at 5%, over and above the Liquidated damages/penalties arising out of "Risk & Cost" as explained above

under. BHEL shall recover the amount from any money due to the Contractor including Security Deposit, or by forfeiting any T&P or material of the contractor under this contract or any other contract of BHEL or by any other means or any combination thereof.

- (iii) To terminate the contract or to restrict the quantum of work and pay for the portion of work executed in case BHEL's contracts with its customer are terminated/ altered/deferred/disputed/on hold for any reason, as per mutual agreement.
- (iv) In event of termination of contract/ withdrawal of work without performing test the vendor shall have no claim to compensate for any loss sustained by him for any reason.
- (v) To effect recoveries from any amounts due to the vendor under this or any other contract or in any other form the moneys which BHEL is statutorily forced to pay to anybody due to contractor's failure to fulfil any of his obligations. BHEL shall levy overheads of 5% on all such payments.
- (vi) To restrict or increase the quantity and nature of work to suit site requirements, since the tender specification is based on preliminary documents and quantities furnished therein are indicative and approximate and the rates quoted shall not be subject to revision.

15.0 Limitation of Liability

Notwithstanding any other provisions, except in cases of wilful misconduct and / or criminal negligence / acts,

- a) Neither the vendor nor BHEL shall be liable to each other, whether in work order / contract, tort (including negligence), or otherwise, for any consequential loss or damage, loss of use, loss of production or loss of profits or interest costs, provided however this exclusion shall not apply to any obligation of the Supplier / Contractor to pay Liquidated Damages to the BHEL as per NIT and
- b) Notwithstanding any other provisions incorporated elsewhere in the contract, the aggregate liability of the vendor in respect of this contract, whether under the Contract, in tort (including negligence) or otherwise, shall not exceed total contract price, however this limitation shall not apply to any obligation of the vendor to indemnify BHEL with respect to Patent Infringement or Intellectual Property Rights.

16.0 Working Time:

Vendor's testing engineer/ operator working time has to be matched with BHEL working time at site. The normal working time (including 1 hr. lunch break) shall be 10 hrs./ day . Working on holiday/ Sunday/ working beyond normal working time will be treated as overtime and shall be paid on pro-rata basis.

17.0 Gate Pass for test kit and test engineer:

Vendor shall arrange the entry/out gate pass for their engineer and test kit for which necessary documents will be forwarded by BHEL to the customer. Vendor shall maintain duly endorsed records of incoming test kit to facilitate grant of outward gate pass.

18.0 Force Majeure:

The following shall amount to Force Majeure:-

- (i) Acts of God, act of any Government, War, Sabotage, Riots, Civil commotion, Police action, Revolution, Flood, Fire, Cyclones, Earth quake and Epidemic, strike and lawful lock-out and other similar causes over which the contractor has no control.
- (ii) If the test could not be performed or delayed on account of force majeure conditions as defined above, the agreed time of completion of the job covered by this contract or the obligations of the contractor shall be extended by a period of time equal to period of force majeure. BHEL in writing shall inform vendor within 7 days from the date of the occurrence of any such eventuality causing delay in execution of contract.
- (iii) If the Force Majeure event(s) continue beyond the period of 15 days, both the parties shall hold consultation to chalk out the further course of action.
- (iv) Neither party can claim any type of compensation from the other party on account of Force Majeure.

19.0 Arbitration:

- (i) Except where otherwise provided for in the contract all questions & disputes relating to the meaning of the specification designs, drawings and instruction herein before mentioned and as to the quality of workmanship or materials used on the work or as to any other question, claim, right, matter or thing whatsoever in any way arising out of or relating to the contract, designs, drawings specifications, estimates, instructions, orders of these conditions or otherwise concerning the works, of the execution or failure to execute the same whether arising during the progress of the work or after the completion or abandonment thereof shall be referred to the sole arbitration of the Head TBG, BHEL, Noida and if the Head TBG is unable or unwilling to act, to the sole arbitration of some other person appointed by the Head TBG willing to act as such arbitrator.

A party wishing to commence arbitration proceeding shall invoke Arbitration Clause by giving 60 days notice to the other party. The notice invoking arbitration shall specify all the points of disputes with details of the amount claimed to be referred to arbitration at the time of invocation of arbitration and not thereafter.

There will be no objection if the arbitrator so appointed is an employee of BHEL and he had to deal with the matters to which the contract relates, in the course of his duties. The arbitrator to whom the matter is originally referred being transferred or vacating his office or being unable to act for any reason such Head TBG as aforesaid at the time of such transfer vacation of office or inability to act shall appoint (see note) another person to act as arbitrator in accordance with the terms of the contract such person shall be entitled to proceed with the reference from the stage at which it was left by his predecessor. It is also a term of this contract that no person other than a person appointed by such Head TBG as aforesaid should act as arbitrator and if for any reason that is not possible the matter is not to be referred to arbitration at all, in all cases where the amount of the claim dispute is Rs. 50,000/- (Rupees fifty thousand) and above the arbitrator shall give reasons for the award. The provisions of Indian Arbitration and Conciliation Act 1996 or any statutory modification or re-enactment thereof and the rules made thereunder and the time being in force shall apply to the arbitration proceeding under this clause.

It is a term of the contract that the party involving arbitration shall specify the dispute or disputes to be referred to arbitration under this clause together with the amounts claimed in respect of each dispute.

The arbitrator may from time to time with consent of the parties enlarge the time for making and publishing the award.

The work under the contract shall, if reasonably possible, continue during the arbitration proceedings and no payment due or payable to the contractor shall be withheld on account of such proceedings.

The Arbitrator shall be deemed to have entered on the reference on the date he issues notice to both the parties fixing the date of the first hearing.

The Arbitrator shall give a separate award in respect of each dispute or difference referred to him.

The Venue of arbitration shall be at New Delhi.

The award of the arbitrator shall be final, conclusive and binding all parties to this contract, subject to the provisions of the Arbitration and Conciliation Act, 1996.

Laws governing the Contract:

The contract shall be governed by the Indians Laws for the time being in force.

NOTE:-The Authority appointing the arbitrator should not be lower in rank than the Authority accepting the Agreement.

- (ii) In case of Contract with Public Sector Enterprise (PSE) or a Government Department through Permanent Machinery of Arbitrators (PMA) in the department of Public Enterprises, the following shall be applicable:

In the event of any dispute or difference relating to the interpretation and application of the provisions of the Contract, such dispute or difference shall be referred to by either party to the arbitration of one of the arbitrators in the department of public enterprises. The award of the arbitrator shall be binding upon the parties to the dispute, provided, however, any party aggrieved by such award may make further reference for setting aside or revision of the award to the Law Secretary, Department of Legal Affairs, Ministry of Law and Justice, Government of India. Upon such reference the dispute shall be decided by the Law Secretary or the Special Secretary or Additional Secretary when so authorized by the Law Secretary, whose decision shall bind the parties hereto finally and conclusively.

- (iii) The cost of arbitration shall be equally by the parties.

- (iv) Neither party shall be entitled for any interest including pre-reference or pendent-lite interest on its claims and any claim for such interest made by any party shall be void.

| ANNEXURE-I | | | | | |
|------------------------|---|------------------------------|-----------------|---|--|
| BOQ CUM PRICE SCHEDULE | | | | | |
| <u>SL</u> | <u>Description</u> | <u>Unit</u> | <u>Quantity</u> | Unit Rate (INR) SERVICES | Total (INR) SERVICES |
| 1 | Hiring of HV Test Kit for conducting test on 400kV GIS on returnable basis. (Time period is excluding to and fro transportation time) | Equipment Functional Days | 7 | 1,86,017 | 13,02,119 |
| 2 | Deputation of Operator/Testing Engineer for conducting HV Test in cordination with the BHEL representative . | Mandays | 7 | 1,08,227 | 7,57,589 |
| 3 | Idling Charges of HV Test Kit and Testing Engineer | Day | 1 | 2,94,245 | 2,94,245 |
| 4 | Mobilisation Charges for HV Test Engineer (includes one time TO and FRO charges of the Bidder's Engineer from Bidders Office/Works to BHEL Site) | Lot | 1 | 1,69,111 | 1,69,111 |
| 5 | Transport Cost for HV Test Kit (includes one time TO and FRO charges of the HV Test Kit from Bidder's Works to Chamera Site) | Lot | 1 | 5,07,335 | 5,07,335 |
| | | | | | 30,30,399 |
| | | | | | Total Ex-works (INR) SERVICES (excluding GST) |

(ANNEXURE-II)

**TRANSMISSION BUSINESS GROUP
(SUB- CONTRACTS MANAGEMENT)
TBG - NOIDA**

PRICE SCHEDULE FORMAT

SUB: Hiring of HV test kit for 400kV GIS at Chamera in Himachal Pradesh

I/ We hereby agree to execute the above work at ----- % (in figure) -----Percentage (in words) Above / Below/ at Par the rates of items given in price schedule/BOQ for hiring of HV Test kit for 400kV GIS at Chamera (Annexure-I) of subject tender.

NOTE:

- 1 The percentage quoted shall be clearly written both in words and figures In case of discrepancy in rates in figure and words, the minimum will be taken into account by BHEL.
- 2 The quoted percentage will apply to the individual items unit rate uniformly.

Signature of tenderer
Name & Designation of authorised person (s) with seal

Date :

Place :

ANNEXURE-III

SUMMARY OF PRICES FOR Hiring of HV test kit for 400kV GIS at Chamera in Himachal Pradesh

| Sl No. | Description | Amount (Rs.) |
|---------------|--|----------------------------|
| 1 | Total amount as per the rates in BOQ for Hiring of HV test kit for 400kV GIS at Chamera in Himachal Pradesh (Annexure-I) | 30,30,399 |
| 2 | Value of percentage above/below/at par (As indicated in Price Schedule Format, Annexure-II) applicable to the total amount of civil work (Sl. no. 1 above) |% above/below/ at par |
| 3 | Total amount after consideration of percentage above/below/ at par. | |

DRAWING-X(C)

M31
3/2/2010

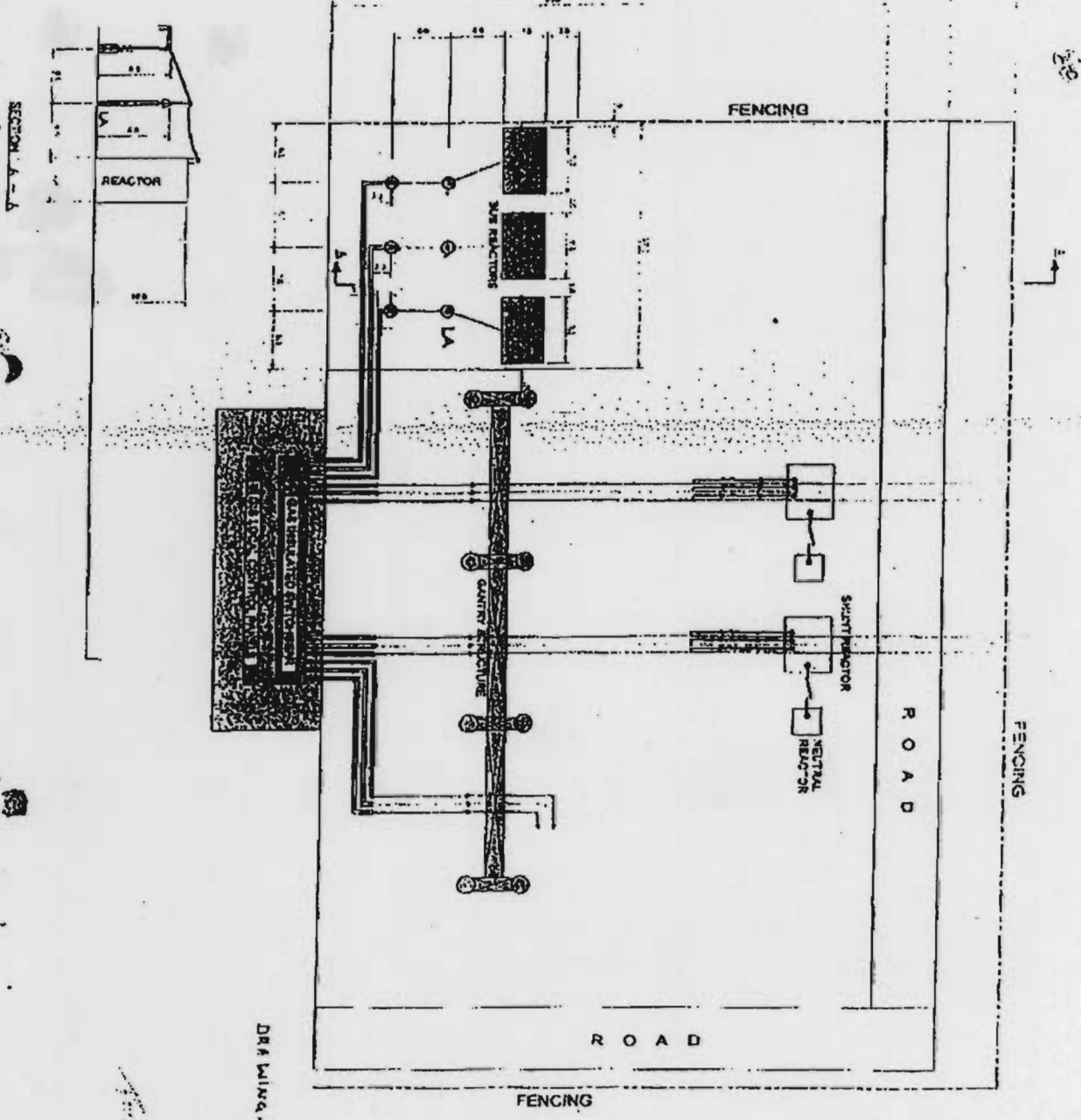

DRAWING-7

Handwritten notes and scribbles.

48

43

pos



80



Annexure A

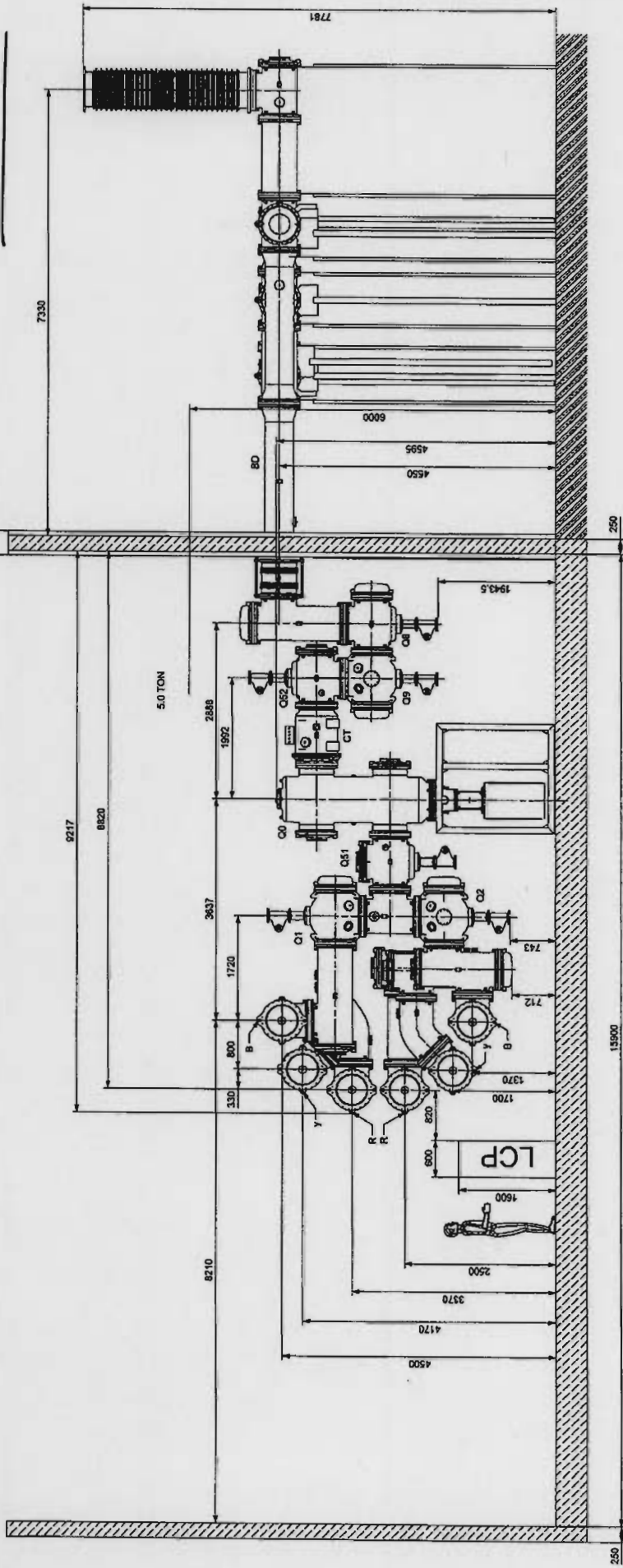

Approved
Signature
Signature

NOTE:
 THIS DRAWING IS MADE FOR GENERAL ARRANGEMENT OF EQUIPMENTS.
 ACTUAL DIMENSIONS MAY VARY DEPENDING UPON DESIGN SITE REQUIREMENT.

| | |
|---|---|
| GIS-220KV M/s. NTPC CHAMERA PROJECT NO. 1111 DRAWING NO. 33209000003 SHEET NO. 04 | |
| DATE: 10/10/11 DRAWING REVISED AS PER CUSTOMER COMMENTS ZONE: | DATE: 10/10/11 DRAWING REVISED AS PER CUSTOMER COMMENTS ZONE: |
| DATE: 10/10/11 DRAWING REVISED AS PER CUSTOMER COMMENTS ZONE: | DATE: 10/10/11 DRAWING REVISED AS PER CUSTOMER COMMENTS ZONE: |

| | |
|---|---|
| DATE: 10/10/11 DRAWING REVISED AS PER CUSTOMER COMMENTS ZONE: | DATE: 10/10/11 DRAWING REVISED AS PER CUSTOMER COMMENTS ZONE: |
| DATE: 10/10/11 DRAWING REVISED AS PER CUSTOMER COMMENTS ZONE: | DATE: 10/10/11 DRAWING REVISED AS PER CUSTOMER COMMENTS ZONE: |

| | |
|---|---|
| DATE: 10/10/11 DRAWING REVISED AS PER CUSTOMER COMMENTS ZONE: | DATE: 10/10/11 DRAWING REVISED AS PER CUSTOMER COMMENTS ZONE: |
| DATE: 10/10/11 DRAWING REVISED AS PER CUSTOMER COMMENTS ZONE: | DATE: 10/10/11 DRAWING REVISED AS PER CUSTOMER COMMENTS ZONE: |

ALL DIMENSIONS ARE IN MM

Annexure A

4602

EXISTING BUS



4049

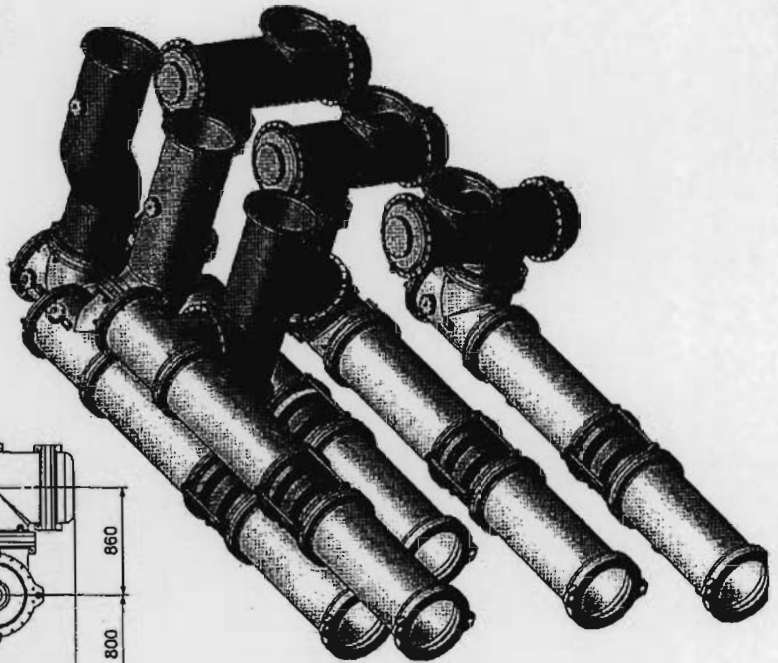
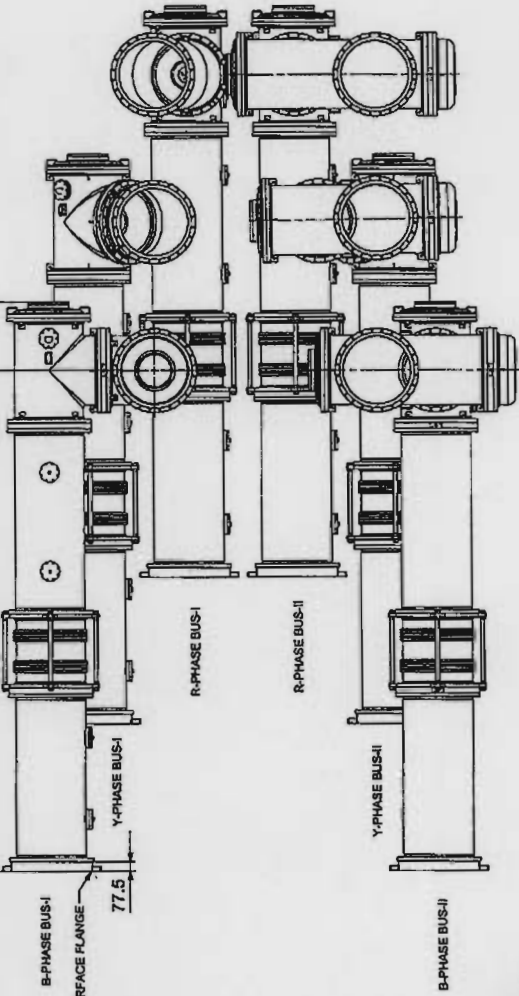
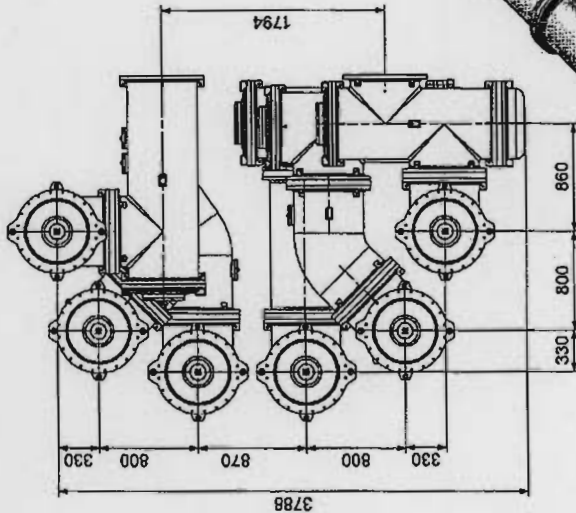

Approved
Sumit
Sanjay

NOTE:
 THIS DRAWING IS MADE FOR GENERAL ARRANGEMENT OF EQUIPMENTS.
 ACTUAL DIMENSIONS MAY VARY DEPENDING UPON DESIGN SITE REQUIREMENT.

| | | | |
|--|--|--|--|
| ADDITIONAL INFORMATION NAME AS PER THE TYPE OF PRODUCT OR NAME OF THE PROJECT PROJECT NO. / SHEET NO. / DATE OF ISSUE DATE OF ISSUE: 15/08/2023 SCALE: 1:1 SHEET NO.: 01 PROJECT NO.: 18/2023/01 | | GIS-420KV M/S. NHPC CHAMERA WITH 10 1/2" dia. INR SHUNT HEAVY ELECTRICAL LTD BHOVAL 42770 ABT, INDIA 1:1 | |
| STATUS OF DRAWINGS DATE BY CHECKED APPROVED DATE | | WITH & DRAWING NO. 3520900003 18/2023/01/01 | |
| DISTRIBUTION OF CHANGES NO. DATE 1. DRAWING ISSUED WITH PROPOSED CHANGES 2. SHEET 4 ADDED | | OCA DRAWING FOR GIS-400KV SHEET NO. 01 | |

THE INFORMATION ON THIS DOCUMENT IS THE PROPERTY OF SHARAD HEAVY ELECTRICALS LIMITED. IT MUST NOT BE USED DIRECTLY OR INDIRECTLY IN ANY MANNER DETRIMENTAL TO THE INTEREST OF THE COMPANY.

INVENTOR NO. DATE
 DESIGNED NO. DATE
 REF Dwg NO. DATE

**FORMAT OF NO DEVIATION CERTIFICATE
(To be submitted in the bidder's letter head)**

REF:.....

Date.....

**BHARAT HEAVY ELECTRICALS LIMITED,
TRANSMISSION BUSINESS GROUP,
5TH FLOOR, ADVANT NAVIS IT BUSINESS PARK,
PLOT No-7, SECTOR-142, EXPRESSWAY NOIDA,
NOIDA-201305
DISTT- G.B.NAGAR (UTTAR PRADESH)**

Sub.: Tender for “hiring of HV test kit for 400kV GIS at Chamera in Himachal Pradesh”

Tender Spec. No. TBSM/CHAMERA/HV TEST KIT/ TENDER/03, Dated 08.06.2018

Dear Sir,

With reference to above, this is to confirm that we have gone through all terms & conditions of the NIT before submission of our offer and noted the job content etc.

We also confirm that we have not changed / modified the tender documents as appeared in the website and in case of observance at any stage, it shall be treated as null and void. We hereby confirm that we have not taken any deviation from tender clauses together with other references as enumerated in the above referred NIT and we hereby convey our unqualified acceptance to all terms and conditions as stipulated in the tender and NIT. In the event of observance of any deviation in any part of our offer at a later date whether implicit or explicit, the deviations shall stand null & void.

We confirm to have submitted offer strictly in accordance with tender instructions.

Thanking you,

Yours faithfully,

(Signature, date & seal of authorized representative of the bidder)

DECLARATION FOR RELATION IN BHEL

(To be typed and submitted in the Letter Head of the Company/Firm of Bidder failing which the offer of Bidder is liable to be summarily rejected)

REF:.....

Date.....

To,

**BHARAT HEAVY ELECTRICALS LIMITED,
TRANSMISSION BUSINESS GROUP,
5TH FLOOR, ADVANT NAVIS IT BUSINESS PARK,
PLOT No-7, SECTOR-142, EXPRESSWAY NOIDA,
NOIDA-201305
DISTT- G.B.NAGAR (UTTAR PRADESH)**

Dear Sir,

Sub : Declaration for relation in BHEL

Ref : 1) NIT/Tender Specification No:,

I/We hereby submit the following information pertaining to relation/relatives of Proprieter/Partner(s)/Director(s) employed in BHEL

Tick(√) any one as applicable:

1. The Proprieter, Partner(s), Director(s) of our Company/Firm DO NOT have any relation or relatives employed in BHEL

OR

2. The Proprieter, Partner(s), or Director(s) of our Company / Firm HAVE relation / relatives employed in BHEL and their particulars are as below:

(i)

(ii)

Signature of the Authorised Signatory

Note:

1. Attach separate sheet, if necessary.
2. If BHEL Management comes to know at a later date that the information furnished by the Bidder is false, BHEL reserves the right to take suitable against the Bidder / Contractor.

