

BHARAT HEAVY ELECTRICALS LTD.
CENTRAL FOUNDRY FORGE PLANT
RANIPUR, HARDWAR
FORGE SHOP MAINTENANCE

Ref.: FF:19:MFG:RC:ME:02

Date: 03/04/2019

TENDER NOTICE – OPEN TENDER

Two part tenders in sealed envelopes are invited from technically and financially capable vendors, having experience in work similar to - and interested in - the under mentioned works. The tender documents are available at website www.bhel.com/www.bhelhwr.co.in in tender notification section which can be downloaded. The tender should be duly filled with all the documents attached. The tender should reach the place specified below **on or before 29.04.2019 at 01:30 PM** which will be opened on the **same day at 02:00 PM** in presence of the bidders who wish to be present at:

Tender Room
Administrative Building
CFFP, BHEL Haridwar – 249403

Bidders are advised to carefully study the drawings before quoting their rates. Bidders are also advised to go through the special Instructions attached to this notice. (Attachment - A). BHEL reserves the right to reject any or all of the tenders without assigning any reason thereto.

Tender No. & Date	Description of Work	Estimated Cost	Earnest Money	Total Time of completion	Tender Cost
FF:19:MFG:RC:ME:02 Dated: 03/04/2019	Final machining, grinding, hard Chrome Plating and buffing of Plungers of 25/50mT Manipulator	Rs. 7.36 lakhs /- (approx.)	Rs. 14722	6 Months	Rs 200.00

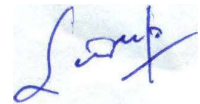

(Sandeep Kumar)
Dy. Mgr./M&S
CFFP, BHEL
Ranipur, Haridwar 249403
(Uttarakhand)
Contact No. 01334-284165
E-mail ID: kum.sandeep@bhel.in



Signature of Issuing Officer

Signature of Bidder/Tenderer

ATTACHMENT-A**SPECIAL INSTRUCTIONS**

1. Kindly read this set of Special Instructions carefully before filling up the tender form.
2. **Pre-qualification requirements placed at annexure A must be fulfilled by the vendor to participate in the tender and submitted along with techno-commercial bid.**
3. The bidders are to submit the tender form along with all the annexures as well as this set of special instructions (Attachment-A); all pages duly signed.
4. The tender is to be submitted in two parts, viz.:
 - 4.1 Techno Commercial Bid, and
 - 4.2 Price Bid

Documents related with pre-qualification requirements i.e. Annexure-A must be submitted along with techno-commercial bid.

5. Both the techno commercial bid and the price bid are to be sealed separately in separate envelopes super-scribed with **“Techno Commercial Bid for Tender no. : FF:19:MFG:RC:ME:02”** and **“Price Bid for Tender no. : FF:19:MFG:RC:ME:02”** respectively and then placed in a common envelope super-scribed with **“Tender for Tender No.: FF:19:MFG:RC:ME:02”**. The techno commercial bid must also contain an un-priced copy of price bid.
6. Only the techno commercial bid will be opened on the day of tender opening. The priced bid will be opened only if and of those vendors whose techno commercial bid(s) are found technically suitable & acceptable. Date of opening of price bid will be intimated to all technically suitable and acceptable bidders at a suitable time.
7. Once price bids are opened and accepted by BHEL, the same cannot be withdrawn by the bidder for whatsoever reasons. In case a bidder withdraws his/her/their tender, suitable action may be taken by BHEL as deemed fit.
8. If there is a difference found in the figures & words of the offered price. The price given in the words will be considered.

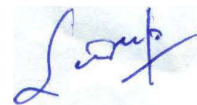

(Issuing Officer)

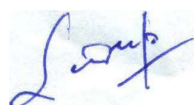

Signature of Issuing Officer

Signature of Bidder/Tenderer

BHARAT HEAVY ELECTRICALS LTD.
CENTRAL FOUNDRY FORGE PLANT
RANIPUR, HARDWAR
FORGE SHOP MAINTENANCE

TENDER FORM for “Final machining, grinding, hard Chrome Plating and buffing of Plungers of 25/50mT Manipulator”.

(PRICE BID)
PRICED/UNPRICED

(PRICED PRICE BID TO BE SEALED IN SEPARATE ENVELOP)

Name & Address of Bidder	:	
Tender Notice No.	:	FF:19:MFG:RC:ME:02
Last Date & Time for receipt of Tender	:	13:30 hrs on 29/04/2019
Date & Time for opening of Tenders	:	14:00 hrs on 29/04/2019
Place for opening of Tenders	:	Tender room, CFFP
Nature of Contract	:	Final machining, grinding, hard Chrome Plating and buffing of Plungers of 25/50mT Manipulator
Period of Contract	:	06 months

SCOPE OF WORK: “Final machining, grinding, hard Chrome Plating and buffing of Plungers as per final drawings. Material of the Plungers is 45C8 and will be supplied by CFFP, BHEL (in rough size). The drawings of rough and final size of the plungers will be provided by CFFP, BHEL. The drawings with mention of “Hard chrome plating” in it are final drawings of Plungers and others are rough drawings of Plungers. All the plungers to be supplied as per dimensions on respective final drawing (including hard chrome plating as mentioned on drawing).

S. No.	Plungers	Final Drawing No.	Qty. (No.)	Quoted Price Per Unit (A1) (Rs.)	Final Quoted Amount (A1*Qty.) (Rs.)
1	FW0320000190: Plunger Ø240 mm for Front Lifting	01-06-054	4		

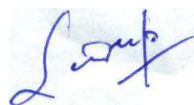

Signature of Issuing Officer

Signature of Bidder/Tenderer

2.	"FW0320000191: Plunger Ø240 mm for Rear Lifting	01-06-056	4		
3.	"FW0320000192: Plunger Ø110 mm of Stuffing Box	01-05-191	9		
4.	"FW0320000193: Cross Head Extension of Power End	01-05-192	6		
Total final quoted cost in figures (Rs.)					
Total final quoted cost in words (Rs.)					

Enclosures:

1. Annexure-A : Pre-Qualification Criteria
2. Annexure-B : Special Terms and conditions
3. Annexure-C : General Terms and conditions
4. Annexure-D : Rough and final Drawings of Plungers

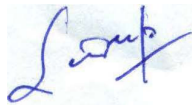

Signature of Issuing Officer

Signature of Bidder/Tenderer

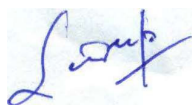

Signature of Issuing Officer

Signature of Bidder/Tenderer

Annexure – A: Pre – Qualification Criteria

S. No.	Criteria	Requirement
1	Vendor must have in-house facilities for finished machining of components of size Ø 100 mm & length 1000 mm or more.	Document mentioning size of Manufacturing Equipment (Lathes, Milling, Grinding Machines etc) installed in the premises of Plant shall be submitted by the vendor
2	Vendor must have in-house facilities for chrome plating. Any authorisation certificate regarding chrome facility from any other dealer will not be considered.	Document mentioning size of plating tank installed in the premises of Plant shall be submitted by the vendor
3	Vender must have successfully completed similar job work/ purchase order of finished machining including chrome plating of components of minimum size Dia. Ø100mm & Length 1000mm.	
3.1	Experience of having successfully completed similar works during last 7 years ending last day of month previous to the one in which applications are invited should be either of the following: Three similar completed works each costing equal to or more than Rs. 2.9 Lakhs Or Two similar completed works each costing equal to or more than Rs. 3.6 Lakhs Or One similar completed work each costing equal to or more than Rs. 5.8 Lakhs	Vendor to submit the copies of purchase orders/completion certificate of work duly signed by customers
3.2	Name & postal address of the customers for whom the above mentioned WOs/POs along with name, contact phone number(s), email id, designation of the contact person to be submitted	Documents detailing the details mentioning: 1. Name of the Company (Customer) 2. Name of the Contact Person 3. Contact Number & E-mail ID To be provided for all the work orders
4	Average annual financial turnover during the last 3 years ending 31st March of the previous financial year, should be at least 2.2 Lakhs.	Balance sheet specifically highlighting Turn Over to be submitted

Note:

1. Similar work means “Final/Finished machining (including machining, grinding, milling, drilling, chrome plating etc.) of components of minimum size Dia. Ø100mm & Length 1000mm.”
2. BHEL reserves the right to verify information submitted by vendor. In case the information is found to be false/ incorrect, the offer shall be rejected.

Signature of Issuing Officer

Signature of Bidder/Tenderer

Annexure – B: Special Terms & Conditions

1. (Rough machined) Material of the components will be provided by BHEL.
2. Bidder has to give bank guarantee of Rs. 250000 against full amount of the rough component/items material cost.
3. CFFP/BHEL reserves the right to pre-inspect the material at vendor's works/ warehouse/ premises before final dispatch and during intermediary processes.
4. The cost of transportation to and fro will be borne by the vendor and is to be included in the bid.
5. The cost of transit insurance during transportation to and fro will be borne by the vendor and is to be included in the bid.
6. The Bidder has to lift the material in one lot.
7. The work period will be 6 months for completion of work on all components and the start of the work period shall be counted from the dispatch date of material from CFFP, BHEL Haridwar Material Gate.
8. The cumulative period (from the start of Work order) for all the lots dispatched by the vendor after final machining (if material is dispatched in lots) and received at CFFP, BHEL material Gate should not exceed 6 Months. If it so exceeds, LD will be imposed accordingly.
9. The vendor will be penalized for late delivery of the material from due date at the rate of 0.5% per week subject to maximum of 10%.
10. The final bid will be evaluated on total landed cost including transportation cost, insurance cost and works inclusive. However, GST will be paid extra on actual basis on submission of GST deposit receipt.
11. Payment shall be made for each received lot of components or in total after receipt and acceptance of material at CFFP works.
12. Original Inspection report indicating surface roughness value, hardness value and all critical dimensions is to be provided.
13. All drawings and standards are propriety of BHEL; they must not be used in any way detrimental to the interest of the company.
14. Lowest bidder (L1) will be decided on total cost of all the Components.

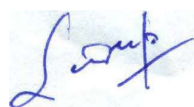

Signature of Issuing Officer

Signature of Bidder/Tenderer

Annexure – C: General Terms & Conditions

Please read the instructions below carefully before filling the tender form. Tender form having any cuttings/overwriting/not having clarity/having ambiguity will be cancelled. Do not remove any page from this form and sign both sides of the pages:

1. No tender documents will be accepted without submission of earnest money.
2. The contractor must sign each page of tender documents. In relation to the company or firm, the tender must be signed by the person who has the power of attorney, and a copy of the same must be enclosed with the tender form.
3. All the tenders must necessarily be accompanied with the earnest money as detailed in the tender notice/tender form. Any tender submitted without the earnest money will be liable to be rejected.
4. Once tenders are opened and accepted by BHEL, the same cannot be withdrawn by the bidder for whatsoever reasons. In case a bidder withdraws his/her/their tender, the earnest money deposited will be forfeited.
5. EMD is to be submitted in the following forms only:
 - (i) Cash deposit as permissible under the extant Income Tax Act (before tender opening)
 - (ii) Electronic Fund Transfer credited in BHEL account (before tender opening)
 - (iii) Banker's cheque/ Pay order/ Demand draft, in favour of BHEL (along with offer)
6. EMD may be waived off in line with statutory regulations if contractor provides necessary certificates/documents as per government notifications.
7. EMD of the tenderer will be forfeited as per tender documents, if:
 - (i) After opening the tender and within the offer validity period, the tenderer revokes his tender or makes any modification in his tender which is not acceptable to BHEL.
 - (ii) The Contractor fails to deposit the required Security deposit or commence the work within the period as per LOI/ Contract.
8. All documents of tender form and earnest money along with the receipt, received after depositing the DD/Pay order (CFFP) to the cash section (if applicable), should be sent to Tender Room, Administrative Building, CFFP by hand/by registered post/by courier in a sealed envelope before opening of tender before the deadline.
9. Contract shall be governed by the works policy, fraud prevention policy and the same shall be made available to the vendor in case of requirement expressed by the vendor. The Bidder along with its associate/collaborators/sub-contractors/sub-vendors/consultants/service providers shall strictly adhere to BHEL Fraud Prevention Policy displayed on BHEL website

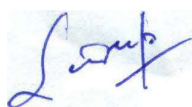

Signature of Issuing Officer

Signature of Bidder/Tenderer

- and shall immediately bring to the notice of BHEL Management about any fraud or suspected fraud as soon as it comes to their notice.
10. BHEL will have the right to cancel any or all tenders and to accept any tender whether it is minimum or maximum. Incomplete forms will be cancelled.
 11. Presence of tenderers at the time of tender opening is recommended but not mandatory.
 12. Bid should be free from correction, overwriting, using corrective fluid, etc. Any interlineation, cutting, erasure or overwriting shall be valid only if they are attested under full signature(s) of person(s) signing the bid else bid shall be liable for rejection.
 13. After getting the contract, security money (SD) has to be deposited by the vendor before commencement of work. The total amount of Security Deposit will be 5% of the contract value. EMD of the successful tenderer shall be converted and adjusted towards the required amount of Security Deposit.
 14. SD may be furnished in any of the following forms:
 - (i) Cash (as permissible under the extant Income Tax Act)
 - (ii) Local cheques of Scheduled Banks (subject to realization)/ Pay Order/ Demand
 - (iii) Draft/ Electronic Fund Transfer in favour of BHEL
 - (iv) Bank Guarantee from Scheduled Banks/ Public Financial Institutions as defined in the Companies Act. The Bank Guarantee format should have the approval of BHEL
 - (v) Fixed Deposit Receipt issued by Scheduled Banks/ Public Financial Institutions as defined in the Companies Act (FDR should be in the name of the Contractor, a/c BHEL)
 - (vi) Securities available from Indian Post offices such as National Savings Certificates, Kisan Vikas Patras etc. (held in the name of Contractor furnishing the security and duly endorsed/ hypothecated/ pledged, as applicable, in favour of BHEL)
 - (vii) (Note: BHEL will not be liable or responsible in any manner for the collection of interest or renewal of the documents or in any other matter connected therewith)

EMD of the successful tenderer can be converted and adjusted against the security deposit. The security deposit shall not carry any interest.
 15. Security deposit shall not be refunded to the contractor except in accordance with the terms of the contract.
 16. No overdue interest clause to be added. If added, BHEL is not liable to entertain the same.
 17. Tenderer has to sign on agreement before taking the Work order.
 18. It is notified to all tenderers that they shall not be submitting any fake documents along with the tender form. All the collected documents can be examined at any point of time and if

Signature of Issuing Officer

Signature of Bidder/Tenderer

documents are found fake/forged, then appropriate action will be taken to the extent of cancellation of registration and tender.

19. In case the contractor defaults in commencing the work within the time specified by BHEL in spite of a reasonable notice in writing or in case the contractor fails, to comply with any of the terms and conditions of the contract, in spite of 10 days' notice in writing or in case he/she neglects or refuses to execute the contract or any part thereof at any stage, the contract shall, without prejudice to any other rights or remedies available to BHEL be liable to cancelled/termination in part or as a whole. In the event of cancellation/termination. The contractor shall be liable to compensate BHEL for all loss incurred by BHEL including the loss suffered on account of having the work executed through any other contractor or department as may be convenient to BHEL in accordance with the exigencies of the work.
20. In the event of cancellation/termination, the contractor shall be liable to compensate BHEL for all losses incurred by BHEL including the loss suffered on account of having the work executed through any other contractor or department as may be convenient to BHEL in accordance with the exigencies of the work. In case only a part of the contract is cancelled, the remaining portion of contract may be allowed to be executed by the contractor. All disputes arising in connection with the contract shall be settled by mutual consultation if no agreement is reached the dispute shall be settled in accordance with the provisions of the Arbitration and conciliation Act, 1996 and the rules made there under. The dispute shall be referred for arbitration to any arbitrator to be appointed by the Head of the BHEL CFFP Unit. The award of the arbitrator shall be final and binding on both the Parties. The venue of the Arbitration shall be Haridwar (U.K.) in India. The questions, disputes, differences arising under, out of or in connection with this contract shall be to the exclusive jurisdiction of Haridwar Courts.

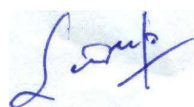

Signature of Issuing Officer

Signature of Bidder/Tenderer

COPYRIGHT AND CONFIDENTIAL
 THE INFORMATION ON THIS DOCUMENT IS THE PROPERTY OF
 BHARAT HEAVY ELECTRICALS LIMITED . IT MUST NOT BE USED DIRECTLY
 OR INDIRECTLY IN ANY WAY DETRIMENTAL TO THE INTEREST OF THE COMPANY.

FIRST ANGLE PROJECTION

(ALL DIMENSIONS ARE IN mm)

REV.	DATE	ALTERED	REV.	DATE	ALTERED	REV.	DATE	ALTERED
		CHECKED			CHECKED			CHECKED

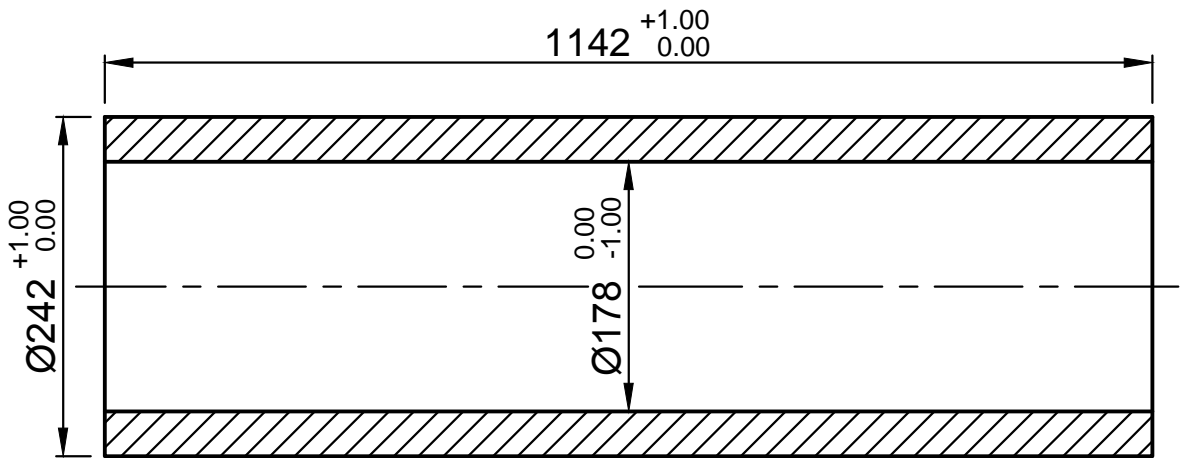

REF. DRG NO.

SIGN & DATE

FOR SUB-CONTRACTING ONLY



BHARAT HEAVY ELECTRICALS LTD
 UNIT: CENTRAL FOUNDRY FORGE PLANT
 HARDWAR

NAME	SIGN	DATE	NO.OF VAR.
DRN PRAVEEN		20.09.18	
CHD ANAMIKA			
APD ARPIT			

INVENTORY NO.

DEPT. M&S
CODE

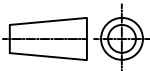

SCALE
NTS

WEIGHT

REF. TO ASSY. DRG.

ITEM NO.

NO.OF ITEMS

TITLE
PLUNGER Ø242
 FOR FRONT LIFTING DEVICE
 MANIPULATOR DEVICE

1

3

DRAWING NO.
01-06-054 (MOD)

SHEET NO.

NO.OF SHEETS

SIZE A4

FIRST ANGLE PROJECTION (ALL DIMENSIONS ARE IN M.M.)

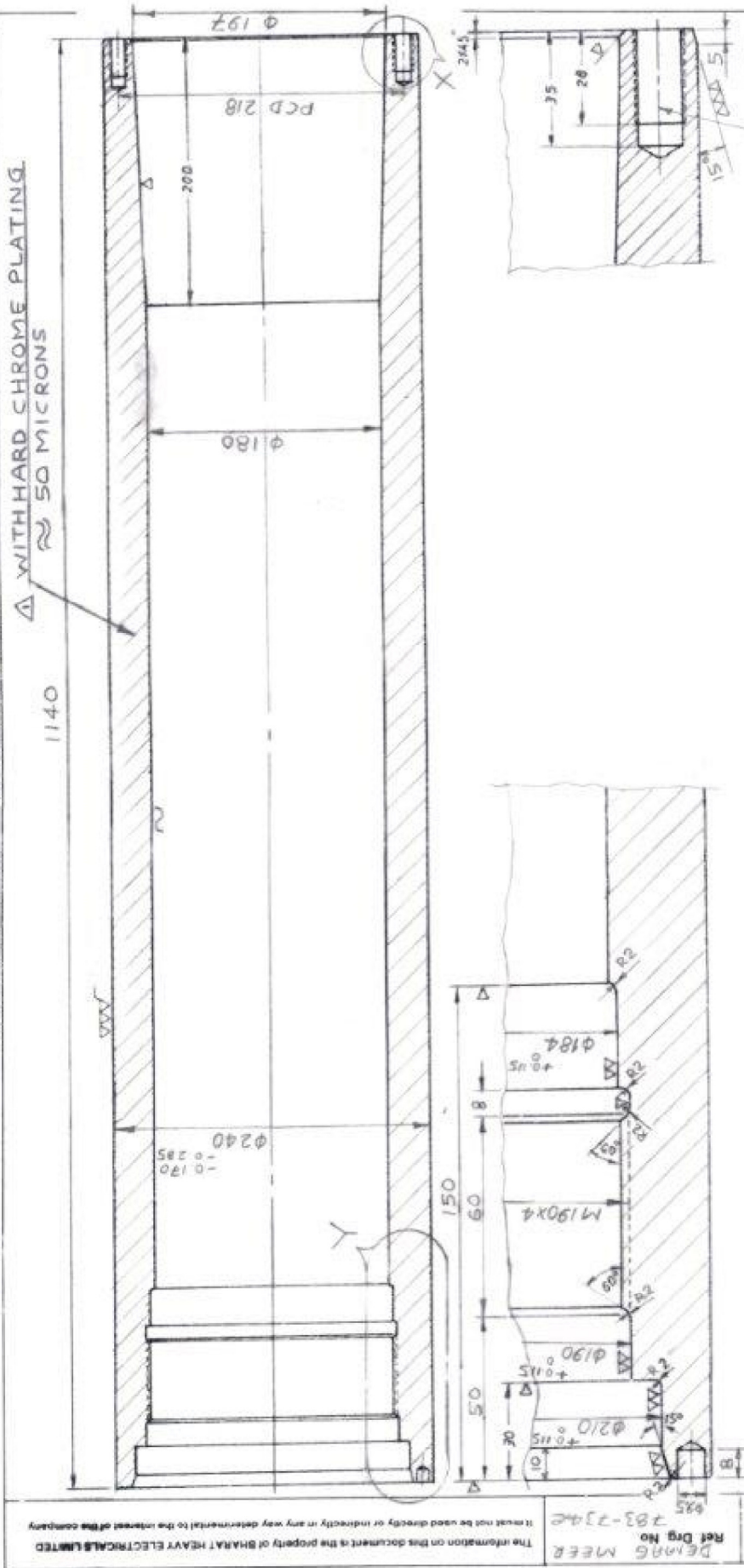

The information on this document is the property of BHARAT HEAVY ELECTRICALS LIMITED. It must not be used directly or indirectly in any way detrimental to the interest of the company.

DEBARG MEER
Ref Drg No 783-734C

Sign & Date

Inventory No

DETAIL - Y

INSTALLED QTY - 2 Nos

DETAIL - X

BHARAT HEAVY ELECTRICALS LIMITED.
UNIT: CENTRAL FOUNDRY FORGE PLANT.
HARDWAR



DEPT DESIGN BUREAU
TITLE PLUNGER Ø 240
FOR FRONT LIFTING DEVICE
MANIPULATOR S.O.M.T

REV DATE ALTERED CHECKED
R1 2.8.10
C HANGED AS MARK

ALL SHARP CORNERS TO BE ROUNDED OFF

WEIGHTINGS	REF TO ASSY DRG	ITEM NO
165 K9		
SCALE NTS	DEPT DESIGN BUREAU	DEPT DESIGN BUREAU
DRAWN KUSHOR DALVI	CHECKED P.B.G.	APPROVED P.B.G.
NAME SIGN	DATE	
	6.8.04	
DRAWING NO		REV
01,06,054		R1
SHEET NO 2	NO OF SHEETS 2	NO OF SHEETS 3

Dimensions to be controlled Within Limits as Shown
Machining Tolerance: 0.25 mm Unless Otherwise Shown Non Machining Tolerance ±

FIRST ANGLE PROJECTION (ALL DIMENSIONS ARE IN M.M.)

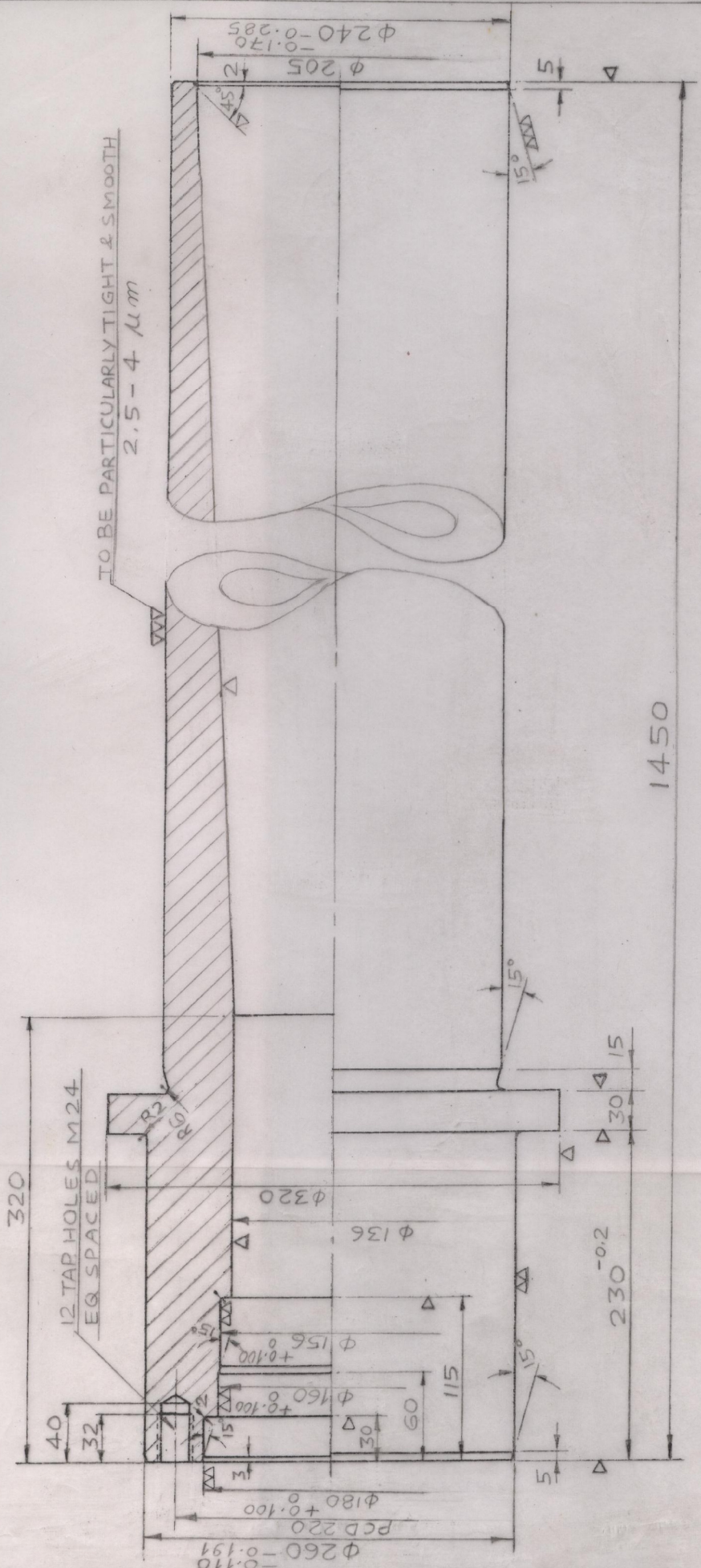

INSTALLED QTY - 2 NOS.

The information on this document is the property of BHARAT HEAVY ELECTRICALS LIMITED. It must not be used directly or indirectly in any way detrimental to the interest of the company.		DEMAG MEER Ref. Drg. No. 783-737C		Sign & Date		Inventory No.	
REV.	DATE	ALTERED CHECKED	REV.	DATE	ALTERED CHECKED	REV.	DATE
ALL SHARP CORNERS TO BE ROUNDED OFF.				MATERIAL - CK60/DIN: 1.1221			
DEPT. DESIGN BUREAU				SCALE NTS			
WEIGHT(KGS.) 305 kg				REF. to ASSY. DRG.			
TITLE PLUNGER φ240 FOR REAR LIFTING DEVICE MANIPULATOR 50MT				DRAWING NO. 01,06,05G			
DIMENSIONS TO BE CONTROLLED WITHIN LIMITS AS SHOWN MACHINING TOLERANCE: 0.25 mm UNLESS OTHERWISE SHOWN. NON MACHINING TOLERANCE ±				SHEET NO. 1 NC. OF SHEETS 1			
C 0.57-0.65, Si 0.15-0.35 Mn 0.60-0.90, P(MAX) 0.035 S(MAX) 0.035				DRAWN KISHORILAL CHECKED P.B.G. APPROVED P.B.G.			
BHARAT HEAVY ELECTRICALS LIMITED. UNIT: CENTRAL FOUNDRY FORGE PLANT. HARDWAR				ITEM NO.			
REV. 1				DATE 13.9.04			

COPYRIGHT AND CONFIDENTIAL
 THE INFORMATION ON THIS DOCUMENT IS THE PROPERTY OF
 BHARAT HEAVY ELECTRICALS LIMITED . IT MUST NOT BE USED DIRECTLY
 OR INDIRECTLY IN ANY WAY DETRIMENTAL TO THE INTEREST OF THE COMPANY.

FIRST ANGLE PROJECTION

(ALL DIMENSIONS ARE IN mm)

REV.	DATE	ALTERED	REV.	DATE	ALTERED	REV.	DATE	ALTERED
		CHECKED			CHECKED			CHECKED

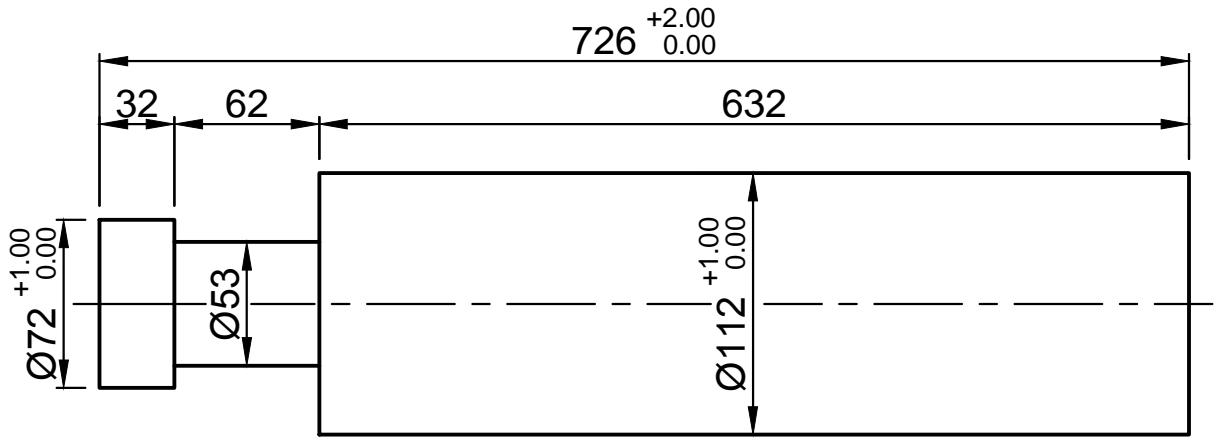

REF. DRG NO.

SIGN & DATE

FOR SUB-CONTRACTING ONLY



BHARAT HEAVY ELECTRICALS LTD
 UNIT: CENTRAL FOUNDRY FORGE PLANT
 HARDWAR

NAME	SIGN	DATE	NO.OF VAR.
DRN PRAVEEN		20.09.18	
CHD ANAMIKA			
APD ARPIT			

INVENTORY NO.

DEPT. M&S
CODE

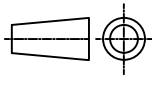

SCALE
NTS

WEIGHT

REF. TO ASSY. DRG.

ITEM NO.

NO.OF ITEMS

TITLE
PLUNGER
 OF STUFFING BOX
 FOR URACA PUMP, 2650T PRESS
 MFS

1 3

DRAWING NO.
01-05-191 (MOD)

SHEET NO. NO.OF SHEETS

SIZE A4

FIRST ANGLE PROJECTION

(ALL DIMENSIONS ARE IN mm)

FORM DG-38(B)

DRAWING NO 01-05-1918

COPYRIGHT AND CONFIDENTIAL
 THE INFORMATION ON THIS DOCUMENT IS THE PROPERTY OF
 BHARAT HEAVY ELECTRICALS LIMITED IT MUST NOT BE USED DIRECTLY
 OR INDIRECTLY IN ANY WAY DETRIMENTAL TO THE INTEREST OF THE COMPANY

WITH HARD CHROME PLATING

≈ 50 MICRONS

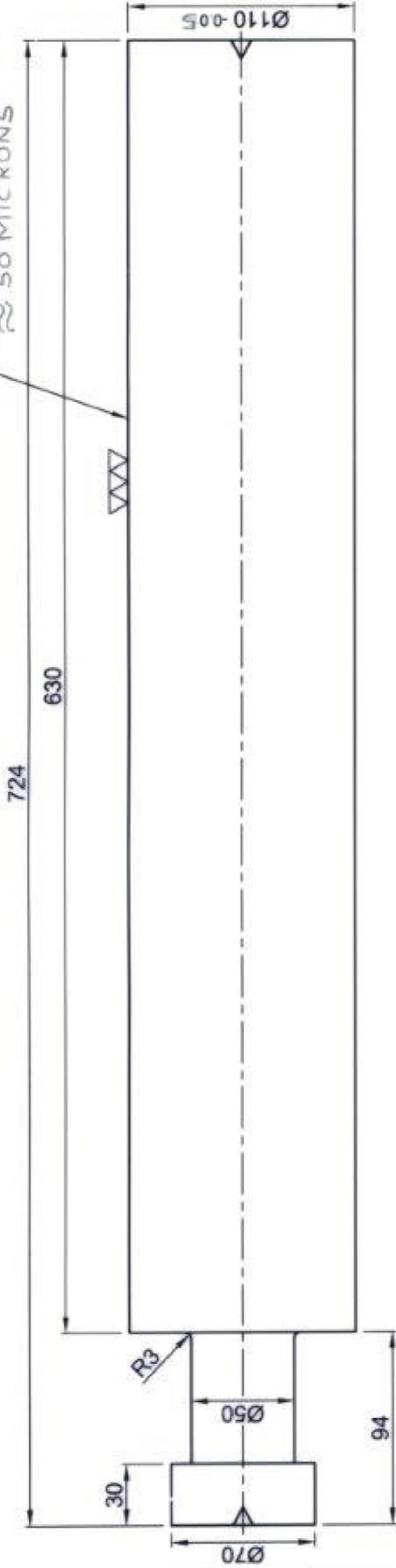

REV	DATE	ALTERED	CHECKED	REV	DATE	ALTERED	CHECKED	MATERIAL	C 35 E
				R1	2.8.18			ADD MICRONS VALVE & CHANGE TOLERANCE ON Ø110	
INVENTORY NO				SIGN & DATE				REF DRG NO	
DRAWING NO 01-05-1918				SIGN				NAME	
R1				CHANDRA				DRN PRAVEEN	
SHEET NO 01				NO OF SHEETS 01				APD SANDEEP	
NO OF ITEMS				REF TO ASSY DRG				CHD JANAMIKA	
19.17				73, 74				PARTS	
NO OF SHEETS 01				SCALE 1:2				WEIGHT	
SIZE A3				DEPT M&S				BHARAT HEAVY ELECTRICALS LTD	
NO OF SHEETS 01				CODE				UNIT CENTRAL PUMPIRY FORCE PLANT	
NO OF SHEETS 01				TITLE				HARDWAR	
NO OF SHEETS 01				FOR URACA PUMP 2650T PRESS				PLUNGER	
NO OF SHEETS 01				MPS				OF STUFFING BOX	

COPYRIGHT AND CONFIDENTIAL

THE INFORMATION ON THIS DOCUMENT IS THE PROPERTY OF
 BHARAT HEAVY ELECTRICALS LIMITED . IT MUST NOT BE USED DIRECTLY
 OR INDIRECTLY IN ANY WAY DETRIMENTAL TO THE INTEREST OF THE COMPANY.

FIRST ANGLE PROJECTION

(ALL DIMENSIONS ARE IN mm)

REV.	DATE	ALTERED	REV.	DATE	ALTERED	REV.	DATE	ALTERED
		CHECKED			CHECKED			CHECKED

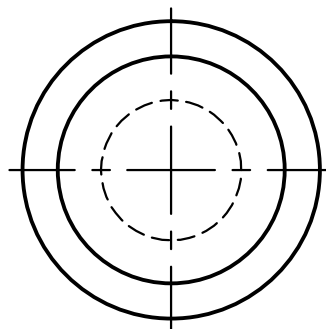
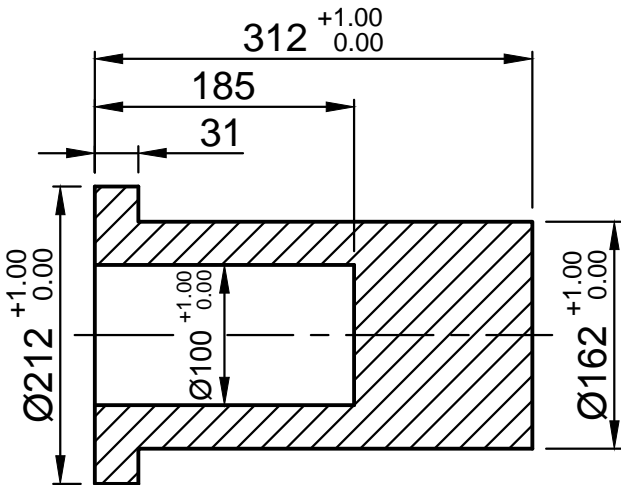

REF. DRG NO.

SIGN & DATE

INVENTORY NO.

FOR SUB-CONTRACTING ONLY

 BHARAT HEAVY ELECTRICALS LTD UNIT: CENTRAL FOUNDRY FORGE PLANT HARDWAR	NAME	SIGN	DATE	NO.OF VAR.
	DRN	PRAVEEN	20.09.18	
	CHD	ANAMIKA		
APD	ARPIT			73, 74

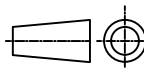
DEPT. M&S		SCALE	WEIGHT	REF. TO ASSY. DRG.	ITEM NO.	NO.OF ITEMS
CODE		NTS				75, 77

TITLE	1	3	DRAWING NO.	
CROSSHEAD EXTENSION			01-05-192 (MOD)	
OF POWER END, URACA PUMP				
FOR 2650T PRESS				
			SHEET NO.	NO.OF SHEETS

SIZE A4

FIRST ANGLE PROJECTION

(ALL DIMENSIONS ARE IN mm)

FORM DG-38(B)

DRAWING NO. 01-05-192A

COPYRIGHT AND CONFIDENTIAL
 THE INFORMATION ON THIS DOCUMENT IS THE PROPERTY OF
 BHARAT HEAVY ELECTRICALS LIMITED. IT MUST NOT BE USED DIRECTLY
 OR INDIRECTLY IN ANY WAY DETRIMENTAL TO THE INTEREST OF THE COMPANY

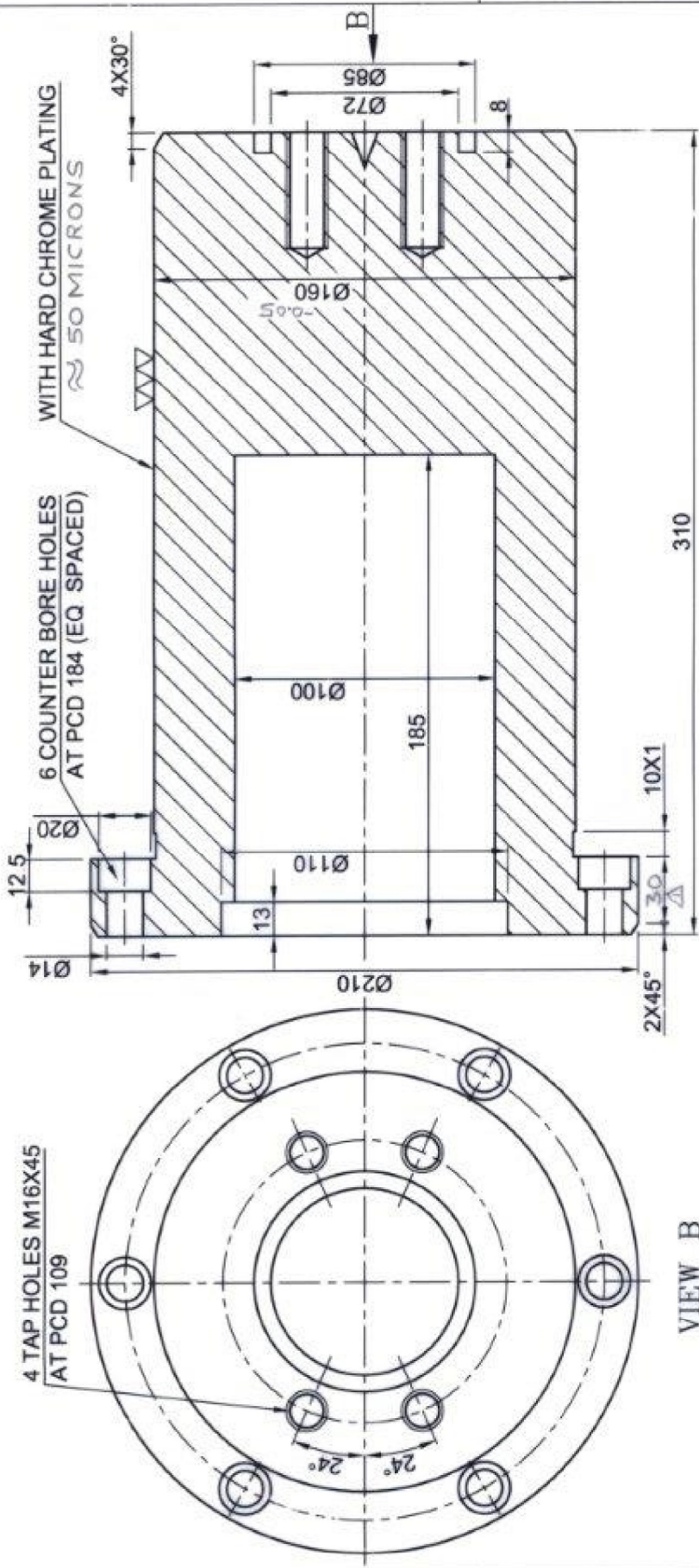

VIEW B

BHARAT HEAVY ELECTRICALS LTD UNIT CENTRAL FOUNDRY FORCE PLANT HARDWAR		NAME PRABEEN ANAMIKA SANDEEP	SIGN [Signature] [Signature] [Signature]	DATE 20.12.17	NO. OF VARI.
DEPT M&S	SCALE N S	WEIGHT	REF TO ASSY DRG	ITEM NO OF NO ITEMS	75.74 75.77
MATERIAL C 35			TITLE CROSSHEAD EXTENSION OF POWER END, URACA PUMP FOR 2650T PRESS		
REV R1	DATE 2.8.18	ALTERED CHECKED	ADD MICRONS VALUE & DIMENSION CHANGE AS MARK Δ		
REV R1	DATE 20.12.17	ALTERED CHECKED	DRAWING NO 01-05-192		
INVENTORY NO			SHEET NO 01 NO OF SHEETS 01		

SIZE A3