

**Name of Woks:** WORKS CONTRACT FOR TUBE EXPANSION OF HEAT EXCHANGERS AT ATP, BHEL-TRICHY FOR 2017-18

**Enquiry No:** 9001600064 /28.12.2016

**BHARAT HEAVY ELECTRICALS LIMITED  
TIRUCHIRAPPALLI-620 014  
WORKS CONTRACTS MANAGEMENT**

**NOTICE INVITING TENDER**

1.	Tender Ref No:	9001600064 /28.12.2016
2.	Name of works	WORKS CONTRACT FOR TUBE EXPANSION OF HEAT EXCHANGERS AT ATP, BHEL-TRICHY FOR 2017-18
3.	Location of work	BHEL, TRICHY.
4.	Period of contract	12 months from the date of award of contract.
5.	Earnest Money Deposit	₹ 84,000/- ( Rupees Eighty four thousand only)
6.	Tender Document details	A] Technical Bid ( Part-I) ANNEX-1A (Technical Bid-Qualifying Criteria) - 02 Pages ANNEX -1B (Scope of Work and Technical Terms & Conditions) - 04 Pages ANNEX -1C (General Terms & Conditions of Contract) - 10 Pages ANNEX: DR.No. 3-HE-170-02702/01 - 01Page B] Price Bid ( Part -II) ANNEX -II (Price bid) - 01 Page
7.	Address for Sending Tender Document along with EMD.	<b>Senior Manager Works Contracts Management (WCM) Building 53,First Floor, BHEL-High Pressure Boiler Plant, Trichy - 620 014</b>
8.	Last Date for submission of Tender Document	19.01.2017 / 10:00 Hrs.
9.	Date of Technical Bid Opening	19.01.2017 / 10:30 Hrs.
10.	Date of Price Bid Opening	Will be intimated separately to Technically qualified vendors.

**Name of Woks:** WORKS CONTRACT FOR TUBE EXPANSION OF HEAT EXCHANGERS AT ATP, BHEL-TRICHY  
FOR 2017-18

**Enquiry No:** 9001600064 /28.12.2016

### **INSTRUCTIONS TO THE TENDERERS**

The offer should be addressed to SENIOR MANAGER, Works Contracts Management, 53 Building, BHEL, Tiruchirappalli 620 014, to reach WCM Dept. on or before **19.01.2017 at 10:00 Hrs.** or the same may be dropped in the Tender Box kept at Works Contracts Management, 53 Building, BHEL, Tiruchirappalli 620 014.

Tenders will be opened on **19.01.2017 at 10:30 Hrs.** (IST) at Works Contracts Management, 53 Building, BHEL, Tiruchirappalli 620 014. BHEL shall not be responsible for any postal delay.

Bidder has to submit (1) Part-I (Techno-Commercial bid) (2) Part-II (Price bid) & (3) EMD draft in separate covers.

a. The first envelope shall contain DD / Pay order drawn in favor of BHEL, Trichy as EMD and super scribed as EMD Cover for NIT / Enquiry No.

Note: **1. Offer without EMD will be rejected.**

**2. EMD may be submitted in the form of DD/Pay Order /Bankers Cheque drawn in favor of BHEL, Trichy (along with offer) or Electronic Fund Transfer credited in BHEL account (before Tender opening). EMD in any other form (Like FD / One Time EMD etc.) is not acceptable.**

b. The second envelope shall be sealed and super scribed as Part-I (Technical Bid for NIT/Enquiry No.)

c. The third envelope shall contain only Part-II (Price bid) for the above work as per scope and to be quoted as per the format given in price bid. Any other information in price bid will not be considered.

The envelope shall be sealed and super scribed as Price Bid for NIT / Enquiry No.

All the above three envelopes shall be kept into one cover ,sealed and super scribed as Tender Document for the work as per NIT (NIT/Enquiry No).

#### **Note:**

1.The contract will be awarded for a period of **12 Months** from the date of ordering.

2.The quoted rates shall be valid up to six months from date of Tender opening.

3.The rates shall remain firm for the entire period of the contract in case WO is awarded.

4.If the Contractor back outs after opening of tender, the contractor is liable for forfeiture of the EMD paid.

**5. Evaluation of the offer shall be done on “Net Cash outflow to BHEL after taking into account applicable Taxes and Duties”.**

6.BHEL reserves the right to increase or decrease the tendered quantity.

**7. BHEL does not guarantee any minimum quantity.**

8.Income Tax deduction at source as applicable in the IT Act from time to time will be made on the value of the bills in the absence of Income Tax Exemption Certificate from the concerned IT officer.

9.All the Statutory Obligations such as ESI, PF, Labor Acts, Factories Act, Service Tax, etc. will have to be taken care of by the vendor. BHEL will have no liability on them. Notwithstanding the above, if any demand notice is served by the concerned Statutory Authorities for recovery of any of their dues on BHEL, the same would be paid to the statutory authorities without notice to the vendor and recovered as a due from any pending / future bills.

10.In case contract is not executed by vendor after award and acceptance of contract, BHEL may exercise the right to forfeit EMD, Security Deposit / BG of such contractors and also suitable action will be taken by BHEL on those Contractors as deemed fit.

**Name of Woks:** WORKS CONTRACT FOR TUBE EXPANSION OF HEAT EXCHANGERS AT ATP, BHEL-TRICHY  
FOR 2017-18

**Enquiry No:** 9001600064 /28.12.2016

#### 11. MSE VENDORS:-

MSE suppliers can avail the intended benefits only if they submit along with the offer, attested copies of either EM II certificate having deemed validity (Five years from the date of issue of acknowledgement in EM-II) or valid NSIC certificate or EM II certificate along with attested copy of a CA certificate (Format is provided as Annexure-A where deemed validity of EM II certificate of five years has expired) applicable for the relevant financial year (latest audited). Date to be reckoned for determining the deemed validity will be the date of bid opening (Part 1 in case of two part bid). Non submission of such documents will lead to consideration of their bids at par with other bidders. No benefit shall be applicable for this enquiry if any deficiency in the above required documents are not submitted before price bid opening. If the tender is to be submitted through e-procurement portal, then the above required documents are to be uploaded on the portal. Documents should be notarized or attested by a Gazetted officer.

**Annexure - A**

#### **Certificate by Chartered Accountant on letter head**

This is to Certify that M/S ..... (Here in after referred to as 'company') having its registered office at ..... is registered under MSMED Act 2006, (Entrepreneur Memorandum No. (Part - II) ..... Dtd: ....., Category: ..... (Micro/Small). (Copy enclosed).

Further Verified from the Books of Accounts that the investment of the company as per the latest audited financial year ..... As per MSMED Act 2006 is as follows:

1. For Manufacturing Enterprises: Investment in plant and machinery (i.e. original cost excluding land and building and the items specified by the Ministry of Small Scale Industries vide its notification No. S.O.1722( E ) dated October 5, 2006 :  
Rs....Lacs.
2. For Service Enterprises: Investment in equipment (original cost excluding land and building and furniture, fittings and other items not directly related to the service rendered or as may be notified under MSMED Act, 2006 :  
Rs...Lac.

**(Strike off whichever is not applicable)**

The above investment of Rs. ....Lacs is within permissible limit of Rs. ....Lacs for..... Micro / Small (Strike off which is not applicable) Category under MSMED Act 2006.

Or

The company has been graduated from its original category (Micro/Small) (Strike off which is not applicable) and the date of graduation of such enterprise from its original category is ..... (dd/mm/yyyy) which is within the period of 3 years from the date of graduation of such enterprise from its original category as notified vide S.O. No. 3322€ dated 01.11.2013 published in the gazette notification dated 04.11.2013 by Ministry of MSME.

Date:

(Signature)

Name -

Membership Number -

Seal of Chartered Accountant.

**ANNEXURE-1A**

**Name of Woks:** WORKS CONTRACT FOR TUBE EXPANSION OF HEAT EXCHANGERS AT ATP, BHEL-TRICHY  
FOR 2017-18

**Enquiry No:** 9001600064 /28.12.2016

**PART-I (TECHNO COMMERCIAL BID)**

**A: Bidder Profile**

1.	Name of the Agency /Company /vendor.	
2.	Address:	
3.	Phone No.:	
4.	E-mail Address:	
5.	Name and Contact details of person for communication related to Tender	
6.	BHEL Vendor Code ( If any )	
7.	Details of tube expansion jobs done for M/s NPCIL.	
8.	List of customers with full address and details of contact person.	
9.	<b>PF Registration (No. &amp; Date )</b> (Copy of PF Registration to be attached)	
10.	<b>ESI Registration (No. &amp; Date )</b> (Copy of ESI Registration to be attached)	
11.	<b>Labour License details.</b> ( Copy of Labour license to be attached )	

**Note:**

- Vendors not having PF Registration /ESI Registration / Labour License (as applicable) shall immediately get registered after award of work to comply with statutory requirements.**
- If vendor fails to get PF / ESI Registration and Labour License (As applicable) within 30 days of award of work, EMD / SD shall be forfeited and penal action shall be taken as per Extant rules of BHEL.**

Contractor Signature

Contractor Seal  
**Page 1 of 2**

**Name of Woks:** WORKS CONTRACT FOR TUBE EXPANSION OF HEAT EXCHANGERS AT ATP, BHEL-TRICHY  
FOR 2017-18

**Enquiry No:** 9001600064 /28.12.2016

**B: Qualifying Criteria:**

Sl. No	Qualifying Criteria	DETAILS	
A	<b>EMD( Earnest Money Deposit ) :</b> Amount: ₹ 84,000 /- (Offer without EMD will be rejected.) (EMD will be waived off for SME/NSIC/SSI vendors upon verification.) ( Copy of valid Certificate to be enclosed)	AMOUNT :₹ DD NO: DD DATE: ISSUING BANK :	
B	<b>Technical Competence :</b>		
B.1	Experience in the field of Tube ID expansion jobs by mechanical process using roller, cage and mandrel. (Evidence in the form of Work order / Contract / Completion certificate to be submitted by the Bidder).		
B.2	Experience of execution of at least one work order for tube ID expansion jobs on tubes of Dia. 19.00 mm or less to a length of around 50 mm placed in a tube sheet of thickness of around 400 mm in both rear and front side of heat exchanger by mechanical process using roller, cage and mandrel during last three years form the date of issue of tender. (Evidence in the form of Work order / Contract /Completion certificate to be submitted by the Bidder).		
C	<b>Financial Soundness:</b> Average annual turnover of ` 15 Lakhs for any two consecutive years during last four financial years ( i.e., 2012-13, 2013-14, 2014-15, 2015-16 ) Vendor to submit <b>IT Return acknowledgement AND (Balance sheet and Profit &amp; Loss statement certified by CA )</b> for any two consecutive years during last four years (2012-13, 2013-14, 2014-15 and 2015-16) or Assessment Year (2013-14, 2014-15, 2015-16, and 2016-17).	<b>Assessment Year</b>	<b>STATUS</b>
		2013-14	
		2014-15	
		2015-16	
		2016-17	
D	<b>Income Tax Registration :</b> Income Tax registration Number (Copy of PAN to be attached)		
E	<b>Service Tax Registration.</b> Service Tax Registration Number (Copy of Service Tax Registration to be attached)		
F	<b>Acceptance to Scope of Work (Annexure-1B), General Terms &amp; Conditions of Contract (Annexure-1C).</b>		

Contractor Signature

**Name of Woks:** WORKS CONTRACT FOR TUBE EXPANSION OF HEAT EXCHANGERS AT ATP, BHEL-TRICHY  
FOR 2017-18

**Enquiry No:** 9001600064 /28.12.2016

**ANNEXURE-IB**

**PART-I (TECHNO COMMERCIAL BID)**

**SCOPE OF WORK AND TECHNICAL TERMS & CONDITIONS**

**A. BILL OF QUANTITY**

<b>SN</b>	<b>Work Description</b>	<b>UOM</b>	<b>APPROX. QTY</b>
1	Tube expansion (4978 Nos. each on primary and secondary side) of SG as per scope of Work. Note: (1 set comprises of 4978 tubes on primary side and 4978 tubes on secondary side of SG )	Set	2

**B.SCOPE OF WORK**

The scope of work for Tube Expansion in 700MWe Steam Generator is as follows:

**4978 tubes to be expanded each on primary side and secondary side of tube sheet of SG and corresponding qualification tests.**

Once the tube expansion process is started in a SG, vendor has to complete the expansion, inspection and rework (if any) within 4 weeks from start of expansion.

**1.0 Job Description:**

**Tube details:**

Matl. Spec INCOLOY-800  
Dimension OD 19.0 +0.12/-0.03 mm  
Thickness 1.1 mm ±10%

**Tube sheet details:**

Matl. Spec 20MnMoNi55  
Tube hole dimension: 19.22 +0.13/-0 mm

Detailed dimensions of tube expansion is given in the attached drawing No. 3-HE-170-02702/01.

**2.0 General points:**

Production job shall be taken up only after successful completion of Qualification test in the presence of customer and establishing parameters for tube expansion and inspection.

**3.0 Equipment:**

Set of torque control unit, drive gun and expander unit (Mandrel, cage and rollers are consumables) are to be identified with equipment serial number. Expander unit shall be of protractive type. The rollers, spindle etc. of the mandrel shall be changed after completion 500 expansions.

Contractor Signature

Contractor Seal

**Name of Woks:** WORKS CONTRACT FOR TUBE EXPANSION OF HEAT EXCHANGERS AT ATP, BHEL-TRICHY  
FOR 2017-18

**Enquiry No:** 9001600064 /28.12.2016

#### **4.0 Trials:**

Setting and to train the operators. The customer shall be furnished with recorded outcome of the trials before taking up PQT. (Procedure Qualification Test)

#### **5.0 Procedure Qualification Test (PQT):**

The process of expansion shall be qualified by performing tube expansion on trial blocks and testing. 40 tubes to be expanded. 20 tubes to be expanded for primary and 20 tubes for secondary expansion.

Block-100mm (min) thickness x 75W x 155L size.

Length of expansion shall be 50mm for both primary and secondary expansion. The dimensions are to be maintained as per drawing no. 3-HE-170-02702/01.

Rolling tool stopper adjustment shall be such that the termination of actual tube to tube sheet contact shall be within the block.

All dimensions shall be measured from the front face of the block.

The tubes shall be held by mechanical methods of expansion. Suitable rigid spacers shall be used when 50mm length secondary side expansion is being qualified to simulate tube sheet nominal thickness in production job.

#### **Acceptance criteria for PQT:**

40 tubes shall be evaluated as follows. 20 tubes for primary and 20 tubes for secondary side expansions.

- a) The expanded portion of tubes shall be free from scratches, dents, cracks, etc. shall be examined visually.
- b) Location, length and smooth transition of expanded portion will be checked.
- c) Percentage of thinning shall lie between 3%-6% measured at 3 locations along the length.  
$$\% \text{ of thinning} = (t1 - t2)/t1 \times 100$$

Where t1: thickness of tube before expansion  
t2: thickness of tube after expansion
- d) Helium leak test shall be conducted on PQT block and Helium leak rate shall not exceed  $1 \times 10^{-7}$  std.cc/sec of helium.
- e) Pullout test shall be done and the load shall be 764 to 1530 kg.

#### **6.0 Personnel qualifications:**

Operators engaged in PQT are automatically qualified for carrying out the job. Any extra operators, if required, shall be qualified by expanding 10 tubes each for primary and secondary expansion in 100mm min. thick block and on satisfactory results of visual examination and dimension measurement.

#### **7.0 Quality Control during Tube Expansion on the job:**

One Tube expansion to be done on Quality control block per shift per machine per operator prior to start of expansion on the job in presence of BHEL/QC and customer. (Minimum of 100 tubes to be expanded in QC blocks per Steam Generator).

Contractor Signature

Contractor Seal

**Page 2 of 4**

**Name of Woks:** WORKS CONTRACT FOR TUBE EXPANSION OF HEAT EXCHANGERS AT ATP, BHEL-TRICHY  
FOR 2017-18

**Enquiry No:** 9001600064 /28.12.2016

The following examination shall be done on expanded QC tube for acceptance.

- a) The expanded portion of tubes shall be free from scratches, dents, cracks, etc.
- b) Location and length of expanded portion.
- c) Percentage of thinning shall lie between 3%-6% measured at 3 locations along the length.
- d) Pullout test shall be done.

#### **8.0 In-Process inspection on the job:**

1. The hole positions of tube expansion in production job with respect to QC tubes shall be recorded and maintained.
2. Reference holes (Qty-50 Nos.) will be identified in the tube sheet during tube sheet drilling. These holes shall be used for in-process inspection during expansion.
3. The percentage of thinning shall be measured for reference holes immediately after expansion. If the percentage of thinning is not within limits, 2 tubes in QC block shall be expanded successfully before continuing on the job.
4. Determine the rolling tool stopper to tube sheet face distances based on actual tube sheet thickness. Adjust the tool stopper setting accordingly before rolling on production job at the start of the shift and verify the same periodically.
5. If any abnormalities are noticed in the production job or QC block, two tubes expanded in the shift by the same operator using same machine shall be examined for corrective action.

The following examination shall be done on production job for acceptance.

- a) ID increase in all the tubes in two dimensions.
- b) Location and Length of expansion in reference holes.
- c) Percentage of thinning in reference holes.
- d) Boroscope check for inner surface of tubes of reference holes and other holes identified by customer.

#### **9.0 Scope of BHEL:**

1. Job will be given for expansion with sufficient lighting / space for expansion
2. Power supply for the Control units of tube expansion at one point nearer to job.
3. Platform arrangement to suit the height of the job
4. Consumables like white cloth, cotton waste for cleaning.
5. Boroscope for ID inspection, Bore dial gauges for final inspection.
6. QC blocks and tubes for trial, PQT, Operator qualification and production control.
7. Boroscope inspection, Pullout test and Helium leak test shall be done by BHEL.

#### **10.0 Scope of Vendor:**

1. Total 4978 tubes to be expanded both on primary side and secondary side of tube sheet of steam generator. Corresponding tube expansions for trials, PQT and QC block are to be done.
2. All the equipment, tools required for tube expansion like torque control units, drive gun, rollers, cage, mandrels and stoppers in sufficient quantity.
3. Expansion oil, in sufficient quantity. Vendor has to specify the oil used.
4. Required measuring instruments with calibration certificates for in-process checking.
5. Extension boxes for power supply
6. 100% Hole ID cleaning with white cloth (provided by BHEL).
7. Holding / suspension arrangements for expansion units.

Contractor Signature

Contractor Seal

**Page 3 of 4**

**Name of Woks:** WORKS CONTRACT FOR TUBE EXPANSION OF HEAT EXCHANGERS AT ATP, BHEL-TRICHY  
FOR 2017-18

**Enquiry No:** 9001600064 /28.12.2016

8. Man power assistance during dimensional check and visual examination of tube ID during BHEL QC and Customer Inspection.
9. Suitable operators for tube expansion. Vendor to specify no. of operators who will be deployed on the job.
10. One qualified supervisor has to be deployed in both the shifts for coordinating with various agencies of BHEL.
11. Arrangements for accommodation / to & fro transportation
12. Separate boxes with lock and key for safe custody of their tools / belongings.
13. Personal protective equipment for the operators engaged in job

**11.0 Special Instructions to vendor:**

- a) Vendor to ensure that there is no breakage of rollers during expansion.
- b) Vendor can deploy manpower in two shifts (G: 8AM to 4.30PM & N: 4.30PM to 1AM).
- c) Vendor has to quote per SG basis taking into consideration of all procedure qualifications and other trial expansions, which are all required for engaging themselves in actual expansion.
- d) Vendor shall co-ordinate to get clearance for all the stages from BHEL/QC and Customer.
- e) All the operators, machines and tools used for the process shall be qualified.
- f) Mandrel and rollers shall be examined by the operator for damage or wear prior to each expansion and periodically after thorough cleaning.

Contractor Signature

Contractor Seal  
**Page 4 of 4**

**Name of Woks:** WORKS CONTRACT FOR TUBE EXPANSION OF HEAT EXCHANGERS AT ATP, BHEL-TRICHY  
FOR 2017-18

**Enquiry No:** 9001600064 /28.12.2016

## **PART-I (TECHNO COMMERCIAL BID)**

**ANNEXURE-IC**

**Name of Vendor:**

### **GENERAL TERMS & CONDITIONS OF CONTRACT**

#### **1. Definition:**

In these General Conditions of Contract, the following terms shall have, I meaning hereby assigned to them, except where the context otherwise requires:

- a) The "Contract" means, the documents forming the tender and acceptance thereof, together with all the documents referred to therein including general and special conditions to contract. All these documents as applicable taken together shall be deemed to form one contract and shall be complementary to one another.
- b) The "Work" means, the work described in the tender documents in individual work orders as may be issued from time to time to the contractor by the Officer-In charge within the power conferred upon him including all notified or additional items of works and obligations to be carried out as required for the performance of contract.
- c) The "contractor" means, the individual Firm or Company whether incorporated or not, undertaking the work and shall include the legal personal representatives of such individuals or the persons composing the firm or Company or the successors of the firm or company and the permitted assigns of such individual or firm or Company.
- d) "The Officer-In charge" means, the Officer deputed by the respective area **HOD** to supervise the work or part of the work.
- e) "Approved" and "Directed" means, the approval or direction of the respective area **HOD** or person deputed by him for the particular purposes.
- f) "BHARAT HEAVY ELECTRICALS LIMITED" (hereinafter referred to as BHEL) shall mean the Board of Directors, Chairman, Executive Director, General Manager or, other Administrative Officer of the said Company including Sr.Manager / WCM authorised to invite tenders and enter into contract for works on behalf of the Company.
- g) The "Contract sum" means, the sum accepted or the sum calculated in accordance with the prices accepted in tender and / or the contract rates as payable to the contractor for the execution of the work during the currency of the contract.
- h) A "week" means, Seven Days, without regard to the number of hours worked or not worked in any day in that week.
- i) A "day" means, the day of 24 hours (TWENTY FOUR) irrespective of the number of hours worked or not worked in that day.

#### **2. Heading to the Contract Conditions:**

The heading to these conditions shall not affect the interpretations thereof.

#### **3. Deviations:**

The contractor shall carry out any Scope of work as per instructions of Executing official.

Contractor Signature

**Name of Woks:** WORKS CONTRACT FOR TUBE EXPANSION OF HEAT EXCHANGERS AT ATP, BHEL-TRICHY  
FOR 2017-18

**Enquiry No:** 9001600064 /28.12.2016

**4. Work To Be Carried Out:**

The Contract shall include all labour which may be required for the execution of the work.

The Contractor will be deemed to have satisfied himself as to the nature of the site, local facilities of access and all matters affecting the execution of the work. No. extra charges consequent on any misunderstanding in these respects or otherwise will be allowed.

**5. Assignment of Transfer of Contract:**

The Contractor shall not, without the prior written approval of the BHEL, assign or transfer the contract or any part thereof, or any share, or interest thereon to any other persons. No sum of money which may become payable under the contract shall be payable to any person, other than the contractor unless the prior written approval of the BHEL to the assignment or transfer of such money is given.

**6. Sub-Contract:**

The Contractor shall not sublet any portion of the contract without the prior written approval of the BHEL.

**7. Compliance to Regulations and Bye-Laws:**

The Contractor shall confirm to the provisions of any statute relating to the work and regulations and Bye-laws of any local authority. The Contractor shall be bound to give all notices required by statutory regulations or by-laws as aforesaid and to pay all fees and taxes payable to any authority in respect thereof.

**8. Earnest Money Deposit (EMD) & Security Deposit (SD):**

**Earnest Money Deposit (EMD):**

Tender must be accompanied by Earnest Money for the amount mentioned in tender notice, pledged to BHEL, Trichy in any of the forms mentioned below.

**Modes of Deposit:**

The EMD shall be accepted only in the following forms:

- a) Cash deposit as permissible under the extant Income Tax Act (before tender opening)
- b) Electronic Fund Transfer credited in BHEL account (before tender opening)
- c) Banker's cheque/ Pay order/ Demand draft, in favour of BHEL (along with offer)

In case total EMD amount is more than ₹ 20 Lakh, the amount in excess of ` 20 lakh may be accepted in the form of Bank Guarantee from scheduled bank. The Bank Guarantee in such cases shall be valid for at least six months.

**Forfeiture of EMD:**

EMD by the tenderer will be forfeited as per tender documents if

- i) After opening the Tender, the Tenderer revokes his Tender within the validity period or increase his earlier quoted rates.
- ii) If only, a part of the work included in the tender has been awarded to the tenderer and the tenderer refuses to take up the work the amount of Earnest Money to be forfeited will be based on the value of the contract so awarded.
- iii) The Tenderer does not commence the work within the period as per LOI / Contract. In case the LOI / Contract is silent in this regard then within 15 days after award of Contract.

**General Terms related to EMD:**

Earnest Money Deposit (EMD) will not carry any interest.

Earnest Money Deposit (EMD) of the successful tenderer will be retained as part of Security deposit.

Contractor Signature

**Name of Woks:** WORKS CONTRACT FOR TUBE EXPANSION OF HEAT EXCHANGERS AT ATP, BHEL-TRICHY FOR 2017-18

**Enquiry No:** 9001600064 /28.12.2016

The Earnest Money Deposit (EMD) will be refunded to the unsuccessful tenderers within 15 days of acceptance of the award of work by successful tenderer / expiry of offer validity period

**Security Deposit (SD):**

The contractor whose tender has been accepted shall, within seven days of receipt of the notification of acceptance of his tender, should deposit Security deposit @ 5 % of Contract value.

EMD of the successful tenderer shall be converted and adjusted towards the required amount of **Security deposit (SD):**

**Modes of Deposit:**

The balance amount to make up the required Security Deposit of 5% of the contract value may be accepted in the following forms:

- i) Cash (as permissible under the extant Income Tax Act)
- ii) Local cheques of Scheduled Banks (subject to realization)/ Pay Order/ Demand Draft/ Electronic Fund Transfer in favour of BHEL
- iii) Bank Guarantee from Scheduled Banks/ Public Financial Institutions as defined in the Companies Act. The Bank Guarantee format should have the approval of BHEL
- iv) Fixed Deposit Receipt issued by Scheduled Banks/ Public Financial Institutions as defined in the Companies Act (FDR should be in the name of the Contractor, a/c BHEL)
- v) Securities available from Indian Post offices such as National Savings Certificates, Kisan Vikas Patras etc. (held in the name of Contractor furnishing the security and duly endorsed/ hypothecated/ pledged, as applicable, in favour of BHEL)

**General Terms related to SD:**

The security Deposit will not carry any interest.

Security Deposit shall be released to the contractor upon fulfilment of Contractual obligations as per terms of contract.

BHEL, shall not be responsible for any loss of securities due to liquidation or any other reason whatsoever or any depreciation in the value of the Securities while in their charge or for any loss of interest thereon.

NOTE: Acceptance of Security Deposit against Sl. No. (iii),(iv) and (v) above will be subject to hypothecation or endorsement on the documents (Signature of the Branch Manager must be present ) in favor of BHEL. However, BHEL will not be liable or responsible in any manner for the collection of interest or renewal of the documents or in any other matter connected therewith.

All compensation or other sums of money payable by the contractor to BHEL under the terms of this contract or under any other contract with BHEL, may be deducted from the Security Deposit or realized by the sale of the securities of from the interest arising there from or from any sums which may be due or may become due to the contractor payable by BHEL, on any account whatsoever against this contract of any other contract with BHEL and in the event of his Security Deposit being reduced by reason of such deductions or sale as aforesaid, the Contractor shall within seven days thereafter make good in cash or in securities endorsed as aforesaid, any sum or sums by which the security Deposit has been so reduced.

In case of an Award of a Contract and if the Contractor fails to perform or does not comply with the Performance Evaluation Criteria, the Security Deposit will not be refunded / Bank Guarantee encashed.

**The Bank Guarantee shall be kept valid until the due date for refund of Security Deposit.**

**Security Deposit has to be deposited within 15 days of LOI/WO. Else EMD will be forfeited and may also attract the provision of "Suspension of Business dealings with Suppliers/Contractors".**

Contractor Signature

**Name of Woks:** WORKS CONTRACT FOR TUBE EXPANSION OF HEAT EXCHANGERS AT ATP, BHEL-TRICHY  
FOR 2017-18

**Enquiry No:** 9001600064 /28.12.2016

#### **9. Orders under the Contract:**

All orders, notices etc. to be given under the contract shall be in writing, typescript or printed and if sent by registered post to the address given in the tender of the Contract, shall be deemed to have been served on the date, when in the ordinary course they would have been delivered to him. The Contractor shall carry out without delay all orders given to him.

Contractor shall be deemed to have included in his tender price of all the plant, machinery and appliances required for the purpose of all operations connected with the work embraced under the contract to secure a satisfactory quality of work and rate of progress which in the opinion of the " Contract Signing Officer" will ensure the completion of the work within the time specified. BHEL is having every right to split the schedule and to award the work to single or many parties on the lowest offered rates basis. This is a time bound contract for period mentioned, and does not envisage any extension of time / period.

#### **10. Contractor's Supervision:**

1. The Contractor shall either himself supervise the execution of the contract or shall appoint a competent agent acceptable to BHEL Officials.
2. Orders given to the Contractor's agent shall be considered to have the same force as if they have been given to the Contractor himself.
3. The Contractor or his accredited agent shall attend when required without making any claim for doing so to the OFFICER-INCHARGE, to receive instructions.
4. The respective area HOD shall have full powers and without assigning any reason, requires the Contractor to immediately cease to employ in connection with this contract, any agent, servant or employee where continued employment is, in his opinion undesirable. The Contractor shall not be allowed any compensation on this account.

#### **11. Labour:**

1. The Contractor shall remain liable for the payment of all wages and other payments in connection with the employees engaged by him and with regard to the work.
2. The Contractor shall comply with the applicable provisions of Payment of Wages Act, 1936, Minimum Wages Act, 1948, Employees Liability Act. 1938, Employees' Compensation Act 1923, Payment of Bonus Act, EPF and Miscellaneous Provisions Act, 1952, Employees State Insurance Act, 1948 and other relevant Acts and rules framed, there under from time to time
3. Contractor shall be responsible for making payment of wages before expiry of 7days from the last day of wage period and shall ensure disbursement of wages in the presence of the authority's representative of contract operating division who shall record under his signature at the end of entries in the Register of wages.
4. Contractor shall have/ obtain license under CL(R&A) Act, 1970.
5. As per BHEL circular HR-Welfare circular dt 08.04.2014, the following additional wages per month has to be paid by the Contractor over and above minimum wages declared by Tamil Nadu Government to labors  
as:  
a) Unskilled : ₹. 3200/  
b) Semi-skilled : ₹. 3700/-  
c) Skilled : ₹. 4100/-

**6. The contractor should remit the salary/wages of their employee only through Bank, directly to the salary/savings account of the employee concerned. Wherever the number of contract workmen employed by the contractor is more than ten and the contract period is more than one month, monthly clearance will be**

Contractor Signature

**Name of Woks:** WORKS CONTRACT FOR TUBE EXPANSION OF HEAT EXCHANGERS AT ATP, BHEL-TRICHY  
FOR 2017-18

**Enquiry No:** 9001600064 /28.12.2016

**given in respect of those contractors, only if the salary/wages to the workmen concerned has been remitted in the bank account of the workmen. The relevant Bank statement/proof for Bank payment should be produced along with PF and ESI challans every month.**

**12. Precautions against Risk:**

The Contractor shall be responsible for providing at his own expense for all precautions to prevent loss or damage from any and all risks and to minimize the amount of any such loss or damage and for the necessary steps to be taken for the said purpose.

**13. Damage & Loss to Private Property & Injury to workmen:**

The Contractor shall at his own expense reinstate and make good to the satisfaction of the respective area **HOD** and pay compensation for any injury, loss or damage occurred to any property or rights whatever including property and rights of BHEL (or agents) servants or employee of BHEL, the injury loss or damage arising out of or in any way in connection with the execution or purported execution of the contract and further the contractor shall indemnify BHEL against all claims enforceable against BHEL (or any agent, servant or employee of BHEL) or which would be so enforceable against BHEL, in respect of any such injury (including injury resulting in death) loss or damage to any person whomsoever or property including all claims which may arise under the Employees Compensation Act or otherwise.

**14. Laws Governing the Contract:**

The contract shall be governed by the Indian Laws for the time being in force.

**15. Cancellation of Contract for Corrupt Acts:**

BHEL, whose decision shall be final and conclusive, shall without prejudice to any other right or remedy which shall have accrued, shall accrue thereafter to BHEL cancel the contract in any of the following cases and the Contractor shall be liable to make payment to BHEL for any loss or damage resulting from any such cancellation to the same extent as provided in the case of cancellation for default.

If the Contractor shall:

a) Offer or give or agree to give to any person in BHEL service any gift or consideration of any kind, as an inducement or reward for doing or for bearing to do or for having done or for having borne to do any act, in relation to the obtaining or execution of this or any other contract for BHEL service,

OR

b) enter into a contract or understanding with any person in BHEL in connection with which commission has been paid or agreed to be paid by him or with his knowledge, unless the particulars of any such commission and the terms of payment thereof have previously been disclosed in writing to BHEL,

OR

c) To obtain' a contract with BHEL as a result of ring tendering or by non-bonafide methods of competitive tendering, without first disclosing the fact in writing to BHEL.

**16. Cancellation of Contract for Insolvency Assignment of Transfer or Subletting Of Contract:**

BHEL, without prejudice to any other right or remedy, which shall have accrued or shall accrue thereafter to BHEL, shall cancel the contract in any of the following cases:

If the Contractor,

Contractor Signature

Contractor Seal  
Page 5 of 10

**Name of Woks:** WORKS CONTRACT FOR TUBE EXPANSION OF HEAT EXCHANGERS AT ATP, BHEL-TRICHY FOR 2017-18

**Enquiry No:** 9001600064 /28.12.2016

a) Being an individual or if a firm any partner thereof shall at any time be adjudged bankrupt or have a receiving order for administration of his estate, made against him or shall take any proceedings for liquidation or composition under any bankruptcy Act or assignment of his effects of composition or arrangement for the benefit of his creditors or purport to do so, or if any application made under any Bankruptcy Act for the time being in force for the sequestration of his estate or if a trust deed be granted by him on behalf of his creditors.

OR

b) Being a Company, shall pass a resolution or Court shall make an order for the liquidation of its assets, or a receiver or Manager on behalf of the debenture holders shall be appointed or circumstances shall arise which entitle the Court or debenture holders to appoint a receiver or Manager.

OR

c) Assigns, Transfers, Sublets or attempts to assign, transfer or sublet any portion of the work without the prior written approval of the BHEL.

d) Whenever BHEL exercises the authority to cancel the contract under these conditions, BHEL may have the work done by any means at the Contractor's risks and expenses provided always that in the event of the cost of the work so done (as certified by the respective area **HOD**) being less than the contract cost, the advantage shall accrue to BHEL and if the cost exceeds the money due to Contractor under the contract, the Contractor shall either pay the excess amount ordered by the respective area **HOD** or the same shall be recovered from the Contractor by other means.

e) In case BHEL carries out the work under the provisions of this condition, the cost to be taken into account in determining the excess cost to be charged to the Contractor under this condition shall consist of the cost of the materials, hire charges of tools and plants and / or labour provided by BHEL with an addition of such percentage to cover superintendence and establishment charges as may be decided by the respective area **HOD** whose decision shall be final and conclusive.

f) Labour engaged by the contractor should be disciplined & exhibit good behaviour in dealing with employees of BHEL. Any misbehaviour or undesirable conduct of any person engaged by the contractor is reported, contractor shall change that person immediately or else it may even lead to termination of the contract & in such case security deposit will be forfeited as penalty.

#### **17. Cancellation of Contract In Part or Full for Contractor's Default:**

If the contractor:

- a) makes default in carrying out the work as directed and continues in that state after a reasonable notice from the respective area **HOD** or his authorized representative:
- b) fails to comply with any of the terms & conditions of the contract or failure to comply orders after reasonable notice in writing with orders properly issued thereunder:

BHEL, May without prejudice to any other right or remedy which shall have accrued or shall accrue thereafter to BHEL CANCEL the contract as whole or in part thereof or only such work order or items of work in default from the contract. Whenever BHEL exercises the authority to cancel the contract as a whole or part under this condition, BHEL may complete the work at the contractor's risk and cost (as certified by the respective area

**HOD** which is final and conclusive) being less than the contract cost, the advantage shall accrue to BHEL. If the cost exceeds the money due to the Contractor under this contract, the Contractor shall either pay the

Contractor Signature

Contractor Seal

Page 6 of 10

**Name of Woks:** WORKS CONTRACT FOR TUBE EXPANSION OF HEAT EXCHANGERS AT ATP, BHEL-TRICHY  
FOR 2017-18

**Enquiry No:** 9001600064 /28.12.2016

excess amount ordered by the respective area **HOD** or the same shall be recovered from the Contractor by other means. In case BHEL carries out the work or any part thereof under the provisions of the conditions the cost to be taken into account in determining the excess cost to be charged to the Contractor under this condition shall consist of the cost of the materials, hire charges of tools and plant and/or labour provided by BHEL with an addition of such percentage to cover the superintendence and establishment charges as may be decided by the respective area **HOD** whose decision shall be final and conclusive.

**18. Termination of Contract on Death of Contractor:**

Without prejudice to any of the rights or remedies under this contract, if the Contractor dies, or if the firm is dissolved or the company is liquidated, BHEL shall have the option of terminating the contract without compensation to the Contractor.

**19. Special Power to Termination:**

If at any time after the award of contract, BHEL shall for any reason whatsoever not require whole or any part of the work to be carried out the respective area **HOD** shall give notice in writing of the fact to the Contractor who shall have no claim to any payment of compensation or otherwise howsoever on account of any profit or advantage which he might have derived from the execution of the work in full but which he did not derive in consequence of the foreclosing of the work.

**20. Submission and Processing Of Bills:**

**Payment of Bills:**

1. Payment will be made after completion of work on pro-rata basis on acceptance and certification of bills by BHEL Engineer.
2. Payment shall be made against Certification by respective area **Engineer in charge**.

The Contractor at the end of each month shall submit a bill in triplicate detailing the various items of work done during the month supported by the requisitions issued from time to time. The Contractor shall, once in every month, submit to the respective area **HOD** separately details of their claims for the work done by them up to and including the previous month which are not covered by their contract agreement in any of the following respects:

- a) Deviation from the items provided in the contract documents.
- b) Extra items / new items of work.
- c) Items in respect of which rates have not been settled. He should in addition furnish a clear certificate to the effect that the claims submitted by him as aforesaid cover all his claims and that no further claims shall be raised by him in respect of the work done up to and including the period under report. Payment will be at the sole discretion of BHEL.

**21. Along with bills, Contractors has to furnish copy of the following documents for further processing of bills:**

- a) Documentary proof for payment of PF/ESI with respect to the employees engaged by the contractor with payment details relating to individual names to be submitted.
- b) Copy of payment challan of previous Month / Quarter as proof of deposit of Service Tax along with a certificate from the Contractor that tax collected from BHEL has been remitted to tax authorities.
- c) Any other relevant document which is required from time to time as per BHEL requirement.
- d) If the Contractor is not registered for any statutory obligation and not liable thereto, then a declaration shall be submitted along with offer that they are within the threshold limit.

Contractor Signature

Contractor Seal  
Page 7 of 10

**Name of Woks:** WORKS CONTRACT FOR TUBE EXPANSION OF HEAT EXCHANGERS AT ATP, BHEL-TRICHY FOR 2017-18

**Enquiry No:** 9001600064 /28.12.2016

**22. Recovery from Contractor:**

Whenever under the contract, any sum of money, shall be recoverable from or payable by the Contractor, the same may be deducted from or any sum then due or which at any time thereafter may become due to Contractor under the contract or under any other contract with BHEL or from his Security Deposit unless the contractor pays the claim on demand.

**23. Post- Technical Audit of Work and Bills:**

BHEL reserves the right to carry out the post-payment Audit and technical examination of the work and final bill including all supporting vouchers, abstracts etc., and enforce recovery of any sum becoming due as a result thereof in the manner provided in the presiding sub- paragraphs. However no such recovery shall be enforced after three years of passing the final bill.

**24. Refund of Security Deposit:**

The Security Deposit mentioned in condition **8** above may be refunded to the Contractor after a period of 6 months on termination or expiry of the contract provided always that the Contractor shall first have been paid the last and final bill and have rendered a "NO DEMAND CERTIFICATE".

**25. Force Majeure Clause:**

If, at any time during the continuance of this Contract the performance in whole or in part by either party of any obligations under this Contract shall be prevented or delayed by reason of any War, Hostile acts of the public enemy Civil Commotion, Epidemics, or Acts of God (Floods, Storm/Cyclone, Hurricane, Earthquake etc. ) then provided notice of happening of any such event is given by either party to other within 7 days from the date of occurrence thereof neither of the parties shall by reason of such event be entitled to terminate this Contract or claim for damages against the other in respect of such non-performance or delay for such period. Performance under the contract shall be resumed as soon as practicable after such event has come to an end or ceased to exist. If the performance in whole or part of any obligation under this Contract is prevented or delayed by reason of any such event, claims for extension of time may be granted for periods considered reasonable by the respective area **HOD** at his discretion subject to prompt notification by the contractor.

**26. Arbitration:**

All disputes between the parties to the contract, arising out of or relating to the contract, other than those for which the decision of the respective area **HOD** or Accepting Officer or any other person is by the contract expressed to be final and conclusive shall after written notice by either party to the contract to the other party be referred to the Arbitrator, to be appointed by the GENERAL MANAGER of BHEL in his sole discretion. Unless the parties otherwise agree, such reference shall not take place until after the completion, alleged completion or abandonment of the work of the determination of the contract. The venue of Arbitration shall be such a place or places, as may be fixed by the Arbitrator in his sole discretion. The award of the Arbitrator shall be final, conclusive and binding on both parties to the contract.

**27. Signing Of Contract:**

Each contract document shall be signed by the Contractor with his usual signature. Contract by partnership or Hindu Joint Family firm, may be signed in the FIRM'S name by the Managing Partner or all /one of the Partners on behalf of the firm or the Karta or Manager for HUF as the case may be. Contract by a Company shall be signed with the name of the Company from a person authorised in this behalf and a Resolution or power of attorney or other satisfactory proof, showing that the person signing the Contract documents on behalf of the Company is duly authorised to do so, shall accompany the contract.

Contractor Signature

Contractor Seal

Page 8 of 10

**Name of Woks:** WORKS CONTRACT FOR TUBE EXPANSION OF HEAT EXCHANGERS AT ATP, BHEL-TRICHY  
FOR 2017-18

**Enquiry No:** 9001600064 /28.12.2016

**28. LIQUIDATED DAMAGES (LD)/PENALTY:**

If the contractor fails to complete the service/work as per terms & conditions of the order within the delivery schedule,

- a) LD shall be levied @ 0.5 % of the order value per week of delay or part thereof subject to a maximum of 5 % of the full order value.
- b) In case of any change to the order value, the LD shall be @ 0.5 % of the revised order value per week of delay or part thereof subject to a maximum of 5% of the revised order value.

**29. Biometric Entry/Exit System for Contract Workmen:**

1. The Entry/Exit of the employees engaged by contractor is to be regulated only through Biometric system.
2. The Contractor initially will be issued with a temporary gang pass for his/her employees for a period of ten days.
3. The contractor should arrange photo coverage for all his/her employees within the above stipulated time.
4. The contractor has to submit FORM-I for all his/her contract employees. All the particulars required in FORM-I are to be provided by the contractor without fail.
5. Every employee of the Contractor shall be provided with Employment Card as per Form XIV (as per Rule 76 of the Contract Labour (Central) Rules, 1971 and the contractor shall instruct its employees to carry the Employment Card as well as Entry Card without fail, while entering/exiting factory.
6. The contractor should educate his employees in registering the attendance through the system.
7. Whenever a contract employee migrates or leaves service of the contractor, the contractor has to surrender the biometric card of the particular employee to Contract Cell with immediate effect, without fail.
8. On completion of the work, the contractor has to surrender all the biometric entry cards issued to its employees immediately to the contract cell. Otherwise, an amount of Rs.100/- per card will be deducted from the final bill/security deposit of the contractor.
9. If any contract employee lose his/her entry card, the contractor shall arrange a duplicate entry card for the employee by paying an amount of Rs.100/-.
10. The Contractor is totally responsible for the biometric cards issued to his/her employee.
11. The Contractor has to indemnify BHEL for all the damages and losses caused by his/her employees.

**30. Common Terms and Conditions for Works Contract relevant to Safety:**

1. All the Contract employees should be trained on Safety and certified by Safety/BHEL. New employees should undergo Safety Training before take up the work, without Safety Training no contract person is allowed to do any work.
2. Use of cell phones and other mobile electronic devices (including hands-free devices) in the work spot and during the operation of a vehicle in the BHEL premises is prohibited.
3. Contract employees working on BHEL premises must wear appropriate personal protective equipment. Strict adherence to all required Personal Protective Equipment (Helmet, Safety Shoes and Goggles) are mandatory, specific PPE requirements will be based on job type or tasks performed.
4. Excessively loose-clothing, dhoti/Lungi is prohibited especially around rotating or moving equipment.

Contractor Signature

Contractor Seal  
Page 9 of 10

**Name of Woks:** WORKS CONTRACT FOR TUBE EXPANSION OF HEAT EXCHANGERS AT ATP, BHEL-TRICHY FOR 2017-18

**Enquiry No:** 9001600064 /28.12.2016

5. The contractors' work area should be kept clean and orderly, free of clutter and trash, so that work may proceed in a safe and orderly manner. Tools should be safely positioned during use and promptly put away when no longer required.
6. Fire-fighting, emergency shutdown devices, and life-saving equipment, should not be blocked by the contractor/employees and access to the path to this equipment should be maintained at all times.
7. Only approved equipment should be used in locations where flammable mixtures are present. A Hot Work Permit is required when open flames, or electric arcs are in the work area and while handling flammable materials.
8. Smoking is not allowed in work area.
9. BHELb operate under a comprehensive Emergency Response Plan. Contractors should be aware of the site Emergency Response Plan and communicate that plan to all their employees.
10. It is recommended that the contractor should know & display the emergency phone numbers like Fire, Ambulance, Safety, Security etc. at their work area.
11. It is the responsibility of the contractor to understand and use the appropriate Work Permits and to verify any permit requirements at the location. Contractor must make necessary arrangements with their Representative to acquire appropriate authorization to perform those operations at the site.

### **31. FRAUD PREVENTION POLICY**

The Bidder along with its associate / collaborators / sub – vendors / consultants / service providers shall strictly adhere to BHEL Fraud Prevention Policy displayed on BHEL website <http://www.bhel.com> and shall immediately bring to the notice of BHEL Management about fraud or suspected fraud as soon as it comes to their notice”.

Fraud Prevention policy and List of Nodal Officers shall be hosted on BHEL website, vendor portals of Units / Regions intranet.

### **32. SUSPENSION OF BUSINESS DEALINGS WITH SUPPLIERS / CONTRACTORS:**

Penal action can be initiated on the suppliers / Contractors in line with extant 'Guidelines for Suspension of Business Dealings with Suppliers/ Contractors. The abridged version of extant 'Guidelines for suspension of business dealings with suppliers/ contractors' has been uploaded on <http://www.bhel.com> on “supplier registration page”.

### **33. RISK PURCHASE:**

a) In the event of any successful Tenderer's failure to fulfil any of the tender / Contract obligations as per Contract / Agreement, BHEL may entrust the job to alternate vendor and get it completed to meet the BHEL requirement and additional expenditure, if any, including consequential cost viz., demurrage etc., will be fully recovered from the Contractor who failed to complete the job in line with the Contract.

b) The decision of BHEL with regard to the actual losses / consequential expenditure incurred by BHEL shall be final and binding on the Contractor.

**In case vendor fails to fulfil any of the tender / Contract obligations as per Contract / Agreement, contract shall be cancelled and SD shall be forfeited**

Contractor Signature

Contractor Seal

Page IO of 10

DRAWING NO: 3-HE-170-02702

U-TUBE (QTY. 2489 No.)  
(INCOLOY-800)

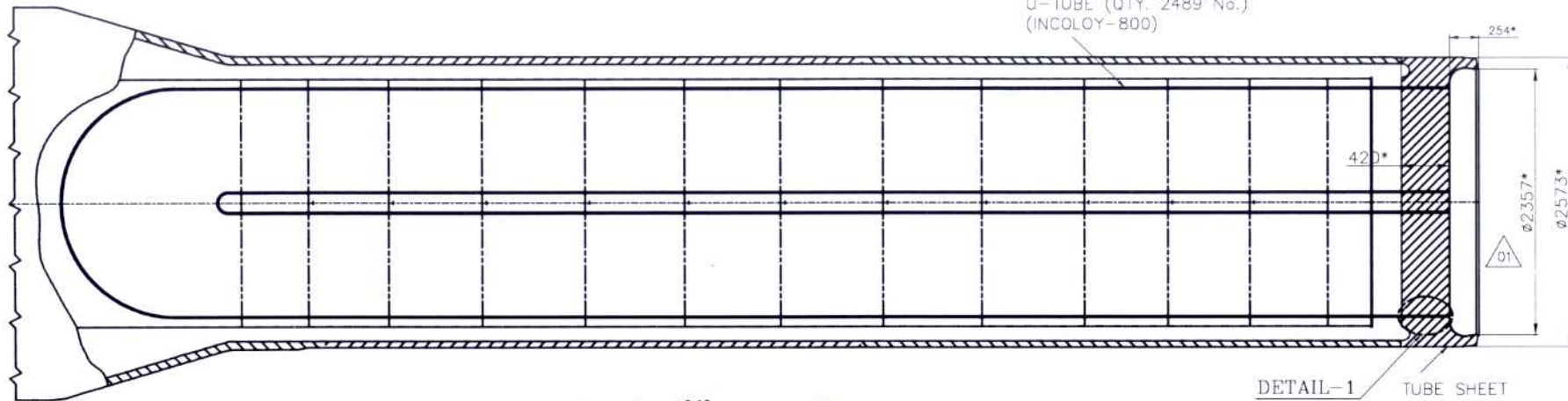

DETAIL-1  
(TYP) TUBE SHEET  
(20MnMoNi55)

U-TUBE [Ø19<sup>+0.12</sup><sub>0.03</sub> x 1.1 THK.]\*  
(QTY. 2489 No.) (INCOLOY-800)

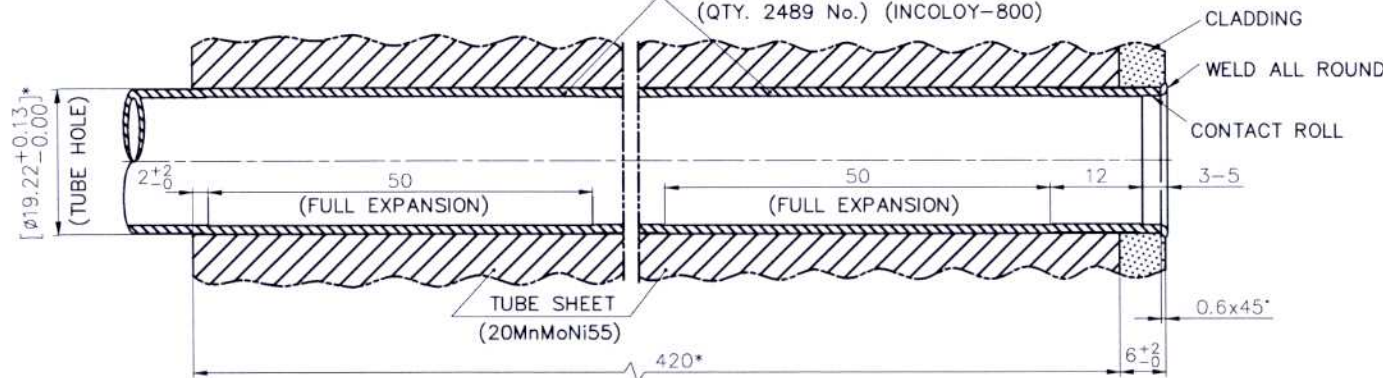

DETAIL-1

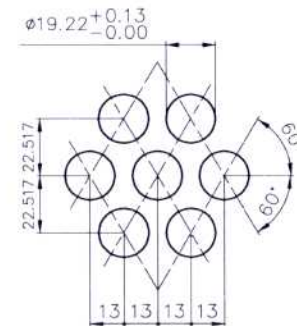

PITCH DETAIL  
(TOTAL No. OF HOLES - 4978)

**NOTE**

01. \* - DIMENSIONS ARE INDICATED FOR REFERENCE ONLY

CAUTION: The information on this document is the property of BHARAT HEAVY ELECTRICALS LTD. It must not be used directly or indirectly in any way detrimental to the interest of the company.

TYPE OF PRODUCT OR NAME OF CUSTOMER/PROJECT  
**700MWe**

 BHARAT HEAVY ELECTRICALS LTD 06-229/D	Bharat Heavy Electricals Ltd UNIT: HIGH PRESSURE BOILER PLANT TIRUCHIRAPALLI - 620014		DRN	NAME RAMESH	SIGNATURE	DATE	NO. OF VAR
			CHD	MAK/RRV	<i>[Signature]</i>	05.11.16	
			APPD	AS	<i>[Signature]</i>	05.11.16	

REV	DATE	ALTERED :
01	061216	CHD&APPD : <i>[Signature]</i>
DIMN. Ø2357 ADDED IN MAIN VIEW.		

DEPT	GRADE OF UNTOOL DIM	SCALE	WEIGHT (Kg)	REF TO ASSY / OLD DWG	ITEM NO	NO OF ITEMS
NC	C/M/F	NTS	-			
CODE	TITLE		CARD CODE	DRAWING NO :		REV
150	TUBE TO TUBE SHEET EXPANSION DETAILS		U 01	3-HE-170-02702		01

**PART-II (PRICE BID)**

**ANNEXURE-II**

01. Rates should be quoted in figures and words and are to be identical if not, the prices in the words will be considered as correct and the same shall be valid and binding.
  - (a) If, in the price structure quoted for the required goods / services / works, there is discrepancy between the unit price and the total price (which is obtained by multiplying the unit price by the quantity), the unit price shall prevail and the total price corrected accordingly, unless in the opinion of the purchaser there is an obvious misplacement of the decimal point in the unit price, in which case the total price as quoted shall govern and the unit price corrected accordingly.
  - (b) If there is an error in a total corresponding to the addition or subtraction of subtotals, the subtotals shall prevail and the total shall be corrected; and
  - (c) If there is a discrepancy between words and figures, the amount in words shall prevail, unless the amount expressed in words is related to an arithmetic error, in which case the amount in figures shall prevail subject of (a) and (b) above.
  - (d) If there is such discrepancy in an offer, the same will be conveyed to the bidder with target date up-to which the bidder has to send his acceptance on the above lines and if the bidder does not agree to the decision of the purchaser, the bid is liable to be ignored.
02. The Rate should be quoted inclusive of Service Tax and inclusive of any taxes and duties levied or to be levied both by Central and State Government authorities from time to time. Service Tax will be paid extra on production of documentary evidence.
03. Quotation should be valid for a period of 120 days from the date of Tender opening.
04. The contract will be awarded to only one contractor based on the total value of the offer. In case of more than one L1 bidders, BHEL gets fresh revised reduced price bids from all such L1 bidders & ranking will be decided based on these revised bids. The new rates quoted should be lower than their previous L1 rates.

SN	Work Description	UOM	APPROX. QTY	Rate/ UOM (₹ / UOM )	Total (₹ )
1	Tube expansion (4978 Nos. each on primary and secondary side) of SG as per scope of Work. <b>Note: (1 set comprises of 4978 tubes on primary side and 4978 tubes on secondary side of SG )</b>	Set	2	₹...../ Rupees..... .....only	₹...../ Rupees..... .....only
Total Value ( ₹ )					
Service Tax @ ____ %( ₹ )					
Total Value Including Service Tax( ₹ )					

**NOTES**

1. The rate quoted shall remain firm and valid for a period and no extra payment will be reimbursed to the contractor by BHEL. Any increase of DA/ wages to the contract labor shall be absorbed by the contractor themselves during the period of contract.
2. Evaluation of the offer shall be done on “Net Cash outflow to BHEL after taking into account applicable Taxes and Duties”.
3. No other pre conditions along with your offer will be entertained by BHEL
4. The signature at the bottom of the rate schedule confirms that the Tenderer had read and accepted all the Terms and conditions in Tender Schedule, also rate quoted with inclusive of any taxes and duties levied and excluding Service Tax etc. has been considered by the tenderer for the total contract period while quoting the above rates.

Contractor Signature

Contractor Seal