

NTPC LIMITED

2X660 MW TALCHER TPP STAGE-III

TECHNICAL SPECIFICATION FOR TG HALL 200/25 T (DOUBLE GIRDER) EOT CRANES

SPECIFICATION NO.: PE-TS-497-501-A501



**BHARAT HEAVY ELECTRICALS LTD
POWER SECTOR PROJECT ENGINEERING MANAGEMENT
NOIDA (U.P.)
INDIA**

	TITLE	SPECIFICATION NO. PE-TS-497-501-A501
	2x660MW TALCHER TPP STAGE-III	REV 00
	DOUBLE GIRDER EOT CRANES ABOVE 100T	Date Dec'22
	CONTENTS	Page 1 of 1

CONTENTS

SECTION	TITLE	PAGE No
I	Specific Technical Requirement	
IA	Specific Technical Requirement (Mechanical)	2-30
	- Customer specification	31-72
	- Annexure I- Makes of sub-vendor items	73-80
	- Annexure II- Mandatory spares	81-82
	- Annexure III- Maintenance Tools and Tackles	83
	- Annexure IV- Painting Specification	84
	- Annexure V- Drawings/ documents to be submitted after award of contract	85-87
	- Annexure VI-Packing Procedure	88
	- Annexure VII- Procedure for Load & Overload testing of Double Girder EOT at Manufacturer's Works	89-90
	- Annexure VIII- Format for O&M manual	91-93
	- Annexure IX- E-Learning package	94-97
	- Crane Clearance Diagram	98-99
	- Standard Quality Plan	100-110
IB	Specific Technical Requirement (Electrical)	111-190
IC	Data Sheet A	191-205
II	Standard Technical Requirement	
IIA	- Standard Technical Requirement (Mechanical)	206-230
	- Site Storage and Preservation Guidelines	231-245
	- General Technical Requirement	246-360
III	Documents to be submitted by the bidder	361
IIIA	List of documents to be submitted with the bid	362
IIIB	Compliance cum Confirmation Certificate	363-364
IIIC	Pre-bid Clarification	365
IIID	Electrical Load data	366
	Input Drawings	367-368

	TITLE	SPECIFICATION NO. PE-TS-497-501-A501
	2x660MW TALCHER TPP STAGE-III	REV 00
	DOUBLE GIRDER EOT CRANES ABOVE 100T	Section I Date DEC'22
SPECIFIC TECHNICAL REQUIREMENTS	Page 1 of 1	

SECTION – I

SPECIFIC TECHNICAL REQUIREMENTS

SUB-SECTION IA – Specific Technical Requirement (Mechanical)

SUB-SECTION IB – Specific Technical Requirement (Electrical)

SUB-SECTION IC – Data Sheet A

1236331/2023/PS-PEM-MAX

	TITLE	SPECIFICATION NO.	PE-TS-497-501-A501
	2x660MW TALCHER TPP STAGE-III	REV 00	
	DOUBLE GIRDER EOT CRANES ABOVE 100T	Section	I A Date DEC'22
SPECIFIC TECHNICAL REQUIREMENTS		Page 1 of 1	

**SUB-SECTION IA
SPECIFIC TECHNICAL REQUIREMENT (MECHANICAL)**

	TITLE	SPECIFICATION NO. PE-TS-497-501-A501
	2x660MW TALCHER TPP STAGE-III	REV 00
	DOUBLE GIRDER EOT CRANES ABOVE 100T	Section I A Date DEC'22
	SPECIFIC TECHNICAL REQUIREMENTS	Page 1 of 2

SCOPE OF ENQUIRY/INTENT OF SPECIFICATION

- 1.1 This specification includes, but not limited to SUPPLY PART, SERVICE PART & MANDATORY SPARES comprising of design (i.e. preparation and submission of drawing /documents including “As Built” drawings and O&M manuals), engineering, manufacture, fabrication, assembly, inspection / testing at vendor's & sub-vendor's works, painting, maintenance tools & tackles fill of lubricants & consumables along with spares for erection, start up and commissioning as required, forwarding, proper packing, shipment and delivery at site, unloading, handling, transportation & storage at site, in-site transportation, assembly, erection & commissioning, trial run at site and carrying out performance guarantee/Functional/Demonstration tests at site (As applicable), and OPERATION AND MAINTENANCE SERVICE including manpower, supervision, consumables etc. for operation & maintenance of cranes for 24 crane-months for each crane after commissioning & handing over in flawless condition of crane(s) for project and package specified above complete with all accessories for the total scope defined as per BHEL NIT & tender technical specification, amendment & agreements till placement of order.
- 1.2 The contractor shall be responsible for providing all material, equipment & services, which are required to fulfil the intent of ensuring operability, maintainability, reliability and complete safety of the complete work covered under this specification, irrespective of whether it has been specifically listed herein or not. **Omission of specific reference to any component / accessory necessary for proper performance of the equipment shall not relieve the contractor of the responsibility of providing such facilities to complete the supply, erection & commissioning and load testing of the cranes and its accessories.**
- 1.3 It is not the intent to specify herein all the details of design and manufacture. However, the equipment shall conform in all respects to high standards of design, engineering and workmanship and shall be capable of performing the required duties in a manner acceptable to purchaser who will interpret the meaning of drawings and specifications and shall be entitled to reject any work or material which in his judgement is not in full accordance herewith.
- 1.4 The extent of supply under the contract includes all items shown in the drawings, notwithstanding the fact that such items may have been omitted from the specification or schedules. Similarly, the extent of supply also includes all items mentioned in the specification and /or schedules, notwithstanding the fact that such items may have been omitted in the drawing.
- 1.5 The general term and conditions, instructions to tenderer and other attachment referred to elsewhere are made part of the tender specification. The equipment materials and works covered by this specification is subject to compliance to all attachments referred to in the specification. The bidder shall be responsible for and governed by all requirements stipulated herein.
- 1.6 While all efforts have been made to make the specification requirement complete & unambiguous, it shall be bidders' responsibility to ask for missing information, ensure completeness of specification, to bring out any contradictory / conflicting requirement in different sections of the specification and within a section itself to the notice of BHEL and to seek any clarification on specification requirement in the format enclosed under Section-III of the specification **within 10 days of receipt of tender documents.** In absence of any such clarifications, in case of any contradictory requirement, the more stringent requirement as per interpretation of Purchaser/Customer shall prevail and shall be complied by the bidder without any commercial implication on account of the same. Further in case of any missing information in the specification not brought out by the prospective bidders as part of pre-bid clarification, the same shall be furnished by Purchaser/ Customer as and when brought to their notice either by the bidder or by purchaser/ customer themselves. However, such requirements shall be binding on the successful bidder without any commercial & delivery implication.
- 1.7 The bidder's offer shall not carry any sections like clarification, interpretations and /or assumptions.
- 1.8 Deviations, if any, should be very clearly brought out clause by clause in the enclosed deviation schedule along with cost of withdrawal; otherwise, it will be presumed that the vendor's offer is strictly in line with NIT

	TITLE	SPECIFICATION NO.	PE-TS-497-501-A501
	2x660MW TALCHER TPP STAGE-III	REV 00	
	DOUBLE GIRDER EOT CRANES ABOVE 100T	Section	I A Date DEC'22
	SPECIFIC TECHNICAL REQUIREMENTS	Page 2 of 2	

specification. If no cost of withdrawal is given against the deviation, it will be presumed that deviation can be withdrawn without any cost to BHEL/its customer.

1.9 In the event of any conflict between the requirements of two clauses of this specification documents or requirements of different codes and standards specified, more stringent requirement as per the interpretation of the owner shall apply.

1.10 In case all above requirements are not complied with, the offer may be considered as incomplete and would become liable for rejection.

1.11 Unless specified otherwise, all through the specification, the word contractor shall have same meaning as successful bidder /vendor and Customer/ Purchaser/Employer will mean BHEL and /or customer including their consultant as interpreted by BHEL in the relevant context. For details refer the relevant clause in GCC.

1.12 Apart from specific design requirement for crane, design of various systems/ Sub-systems and all equipment will also strictly meet the stipulations of Customer's Technical Specification.

Note:

Bidder to note that BHEL reserves the right for drawing/document submission through web based Document Management System. Bidder would be provided access to the DMS for drawing/document approval and adequate training for the same. Detailed methodology would be finalized during the kick-off meeting. Bidder to ensure following at their end.

- Internet explorer version – Minimum Internet Explorer 7.
- Internet speed – 2 mbps (Minimum preferred).
- Pop ups from our external DMS IP (124.124.36.198) should not be blocked.
- Vendor's internal proxy setting should not block DMS application's link.

<http://dms-server.bhelnem.com/Wrench%20Web%20Access/Login.aspx>

1236331/2023/PS-PEM-MAX

	TITLE	SPECIFICATION NO. PE-TS-497-501-A501
	3X800 MW PATRATU STP	VOLUME: II B
	DOUBLE GIRDER EOT CRANES ABOVE 100T	REV 00
	SPECIFIC TECHNICAL REQUIREMENTS	Section I A Date DEC '22
		Page 1 of 1

PROJECT INFORMATION

CLAUSE NO.	PROJECT INFORMATION			
<p>1.00.00</p> <p>2.00.00</p> <p>2.01.00</p> <p>3.00.00</p> <p>3.01.00</p> <p>3.02.00</p> <p>3.03.00</p> <p>3.03.01</p> <p>3.03.03</p> <p>3.03.03</p>	<p style="text-align: center;">TALCHER TPP STAGE-III (2X660 MW)</p> <p>BACKGROUND</p> <p>Talcher Thermal Power Project is situated near Talcher town in Angul district of Orissa having capacity of 460 MW (4x60 MW + 2x110 MW). The project was implemented by Orissa State Electricity Board (OSEB). Subsequently TTPS was taken over by NTPC on 03.06.1995. The present proposal is for expansion of TTPS by adding 2 units of 660 MW.</p> <p>PROJECT HIGHLIGHTS</p> <p>Location</p> <p>The proposed site is located near Talcher town in Angul district of Orissa having latitude and longitude as 20°55' N and longitude 85°25' E respectively. The site is approachable from Banarpal–Talcher section of National Highway No. 23 at a distance of about 1 km from Anand Bazar. Nearest railway station is at Talcher on Talcher-Cuttack section of North Eastern Railway at about 4 Kms. The nearest commercial airport is Bhubaneswar at about 90 km.</p> <p>Vicinity Plan of the proposed project is placed at Annexure-I.</p> <p>BASIC INPUTS</p> <p>Land</p> <p>The plant facilities for this expansion stage would be accommodated within the land available in the existing power station and ash disposal shall be in mine voids.</p> <p>Water</p> <p>Make up water requirement for Talcher Thermal power project, Stage-III expansion (2x660 MW) would be about 40 Cusec with ash water recirculation system. Water requirement for the project will be met from upstream of the Samal barrage discharge on the River Brahmani and shall be pumped to the raw water reservoir located about 28 kms from intake well.</p> <p>FUEL</p> <p>Coal Requirement, Availability and Linkage</p> <p>The Coal Linkage for the project granted by SLC(LT) and CLOA has allocated 5.854 MMTPA coal from MCL.</p> <p>The primary fuel for the main steam generator shall be coal. The domestic coal quality parameters are indicated in Annexure-IV-2 and imported coal parameters are indicated in Annexure-IV-4 are to be considered for steam generator design.</p> <p>Coal Transportation</p> <p>The envisaged mode of coal transportation from the coal mines to the power plant is through Indian Railways network and will be unloaded in underground RCC Track Hoppers.</p> <p>Fuel Oil</p> <p>The fuel oil to be used for start-up, coal flame stabilization and low load operation of the steam generator shall be Light Diesel oil (LDO) having the characteristics given at Annexure-IV-1 and HSD Oil characteristics given at Annexure-IV-3.</p>	<p>TECHNICAL SPECIFICATION SECTION – VI, PART-A BID DOC. NO CS-4540-001A-2</p>	<p>SUB-SECTION-IB PROJECT INFORMATION</p>	

CLAUSE NO.	PROJECT INFORMATION			एनटीपीसी NTPC
4.00.00	<p>STEAM GENERATOR TECHNOLOGY</p> <p>The steam generators shall be super critical once through type, water tube, direct pulverized coal fired, top supported, balanced draft furnace, single reheat, radiant, dry bottom type, suitable for outdoor installation. The gas path arrangement shall be single pass (Tower type) or two pass type.</p>			
5.00.00	<p>FLUE GAS DESULPHURIZATION SYSTEM (FGD) & SCR ready system:</p> <p>The project is envisaged with Flue Gas Desulfurization (FGD) system and DeNOx ready system meeting Ministry of Environment, Forest & Climate Change notification dated 07.12.2015. Limestone to be used for design of FGD system shall be as per the characteristic given at Annexure-IV-5.</p>			
6.00.00	<p>CAPACITY</p> <p>Talcher TPP, Stage-III : 2x660 MW - Present proposal</p>			
7.00.00	<p>BENEFICIARY STATES</p> <p>The project is being implemented as a regional project for meeting the power demand of Eastern Region Beneficiaries including Orissa – the home-state. The exact allocation of power shall be subject to the approval of Ministry of Power, Govt. of India.</p>			
8.00.00	<p>METEOROLOGICAL DATA</p> <p>The meteorological data from nearest observatory is placed at Annexure-II.</p>			
9.00.00	<p>Plant Water Scheme</p> <p>The Plant water scheme is included in Part-E of Technical Specification.</p>			
9.01.00	<p>Condenser Cooling (CW) Water System</p> <p>It is proposed to adopt a recirculating type cooling water system with cooling towers for the project. For the re-circulating type CW system it is proposed to supply clarified water as make up. Circulating water from CW pumps to TG area and from TG area to cooling tower will be carried through pipes/ducts. Cooled water from cooling tower will be led to CW pump house through the cold water channel by gravity.</p>			
9.02.00	<p>Equipment Cooling Water (ECW) System (Unit Auxiliaries)</p> <p>All plant auxiliaries shall be cooled by De-mineralized water (DM) in a closed circuit. The primary circuit DM water shall be cooled through plate type heat exchangers by Circulating Water tapped from CW system in a closed secondary circuit. The hot secondary circuit cooling water shall be cooled in the cooling towers and shall be returned back to the system.</p> <p>It is proposed to provide independent primary cooling water circuit for TG & its auxiliaries and Steam Generator & auxiliaries (including station auxiliaries) on Unit basis.</p>			
9.03.00	<p>Other Miscellaneous Water Systems</p> <p>CW system blow down water shall be used for the FGD process requirement, ash slurry pumps sealing, sealing of Vacuum pumps (if applicable) of Ash Handling plant, make-up to fire water system. The service water shall be taken from clarified water tank of Pre-treatment plant. The service (wash water) water collected from various areas and coal handling plant shall be treated as per requirement and reused. The drinking water requirement shall be provided from water treatment plant.</p>			
<p>TALCHER THERMAL POWER PROJECT STAGE-III (2X660 MW) EPC PACKAGE</p>		<p>TECHNICAL SPECIFICATION SECTION – VI, PART-A BID DOC. NO CS-4540-001A-2</p>	<p>SUB-SECTION-IB PROJECT INFORMATION</p>	<p>PAGE 2 OF 15</p>

CLAUSE NO.	PROJECT INFORMATION		
<p>10.00.00</p> <p>11.00.00</p> <p>12.00.00</p> <p>13.00.00</p>	<div style="text-align: right; border: 1px solid black; padding: 2px; width: fit-content; margin: 0 auto;"> एनटीपीसी NTPC </div> <p>The quality of Raw water is given in this sub-section at Annexure-III</p> <p>POWER EVACUATION SYSTEM</p> <p>In view of above and considering the present capacity of the project (1320 MW), it is proposed to adopt the step-up/power evacuation voltage as 400kV. Accordingly provision for 4 Nos. of 400 kV line bays has been considered in the generation switchyard. Station supply shall be derived directly from 400kV voltage level through 400kV Class station transformers. The issue of power evacuation of the project shall be taken up with appropriate Transmission Utility as per regulatory provision, based on final power allocation received from Ministry of Power.</p> <p>Criteria for Earthquake Resistant Design of Structures and Equipment</p> <p>All power plant structures and equipment, including plant auxiliary structures and equipment shall be designed for seismic forces as given in Part-B of this section.</p> <p>Criteria for Wind Resistant Design of Structures and Equipment</p> <p>All structures and equipment of the power plant, including plant auxiliary structures and equipment, shall be designed for wind forces as given as given in Part-B of this section.</p> <p>Vulnerability Atlas of India(VAI), prepared by Building Materials, Training and Promotion Council (BMTPC) under Ministry of Housing and Urban Affairs, is a comprehensive document which provides existing hazard scenario for the entire country and presents the digitized State/UT-wise hazard, maps with respect to earthquakes, winds and floods for district-wise identification of vulnerable areas. It also includes additional digitized maps for thunderstorms, cyclones and landslides. The main purpose of this Atlas is its use for disaster preparedness and mitigation at policy planning and project formulation and construction stage. The VAI provides necessary information for risk analysis and hazard assessment and is available at website www.bmtpc.org.</p> <p>As per Government's directive, it is mandatory for the bidders to refer VAI for multi-hazard risk assessment and include the relevant hazard proneness specific to project location while planning, designing and execution of the project in terms of following details:</p> <ol style="list-style-type: none"> i) Seismic zone (II to V) for earthquakes ii) Wind velocity iii) Area liable to floods and Probable max. surge height iv) Thunderstorms history v) Number of cyclone storms/sever cyclone storms and max sustained wind specific to coastal region vi) Landslides incidences with Annual rainfall normal vii) District wise Probable Max. Precipitation <p>Accordingly, bidder should refer VAI while planning, designing and execution of the project. However, for design of structures/facilities and equipment, the criteria for earthquake resistant design of structures and equipment, the criteria for Wind Resistant Design of Structures and Equipment and design parameters for drainage facilities, stipulated in the Technical Specification shall be followed.</p> <p>For other information like area liable to floods, probable max. surge height, landslide, thunderstorm, cyclone etc. agencies are required to refer the VAI.</p>		
<p>TALCHER THERMAL POWER PROJECT STAGE-III (2X660 MW) EPC PACKAGE</p>	<p>TECHNICAL SPECIFICATION SECTION – VI, PART-A BID DOC. NO CS-4540-001A-2</p>	<p>SUB-SECTION-IB PROJECT INFORMATION</p>	<p>PAGE 3 OF 15</p>

CLAUSE NO.	PROJECT INFORMATION	
------------	---------------------	---

ANNEXURE-I

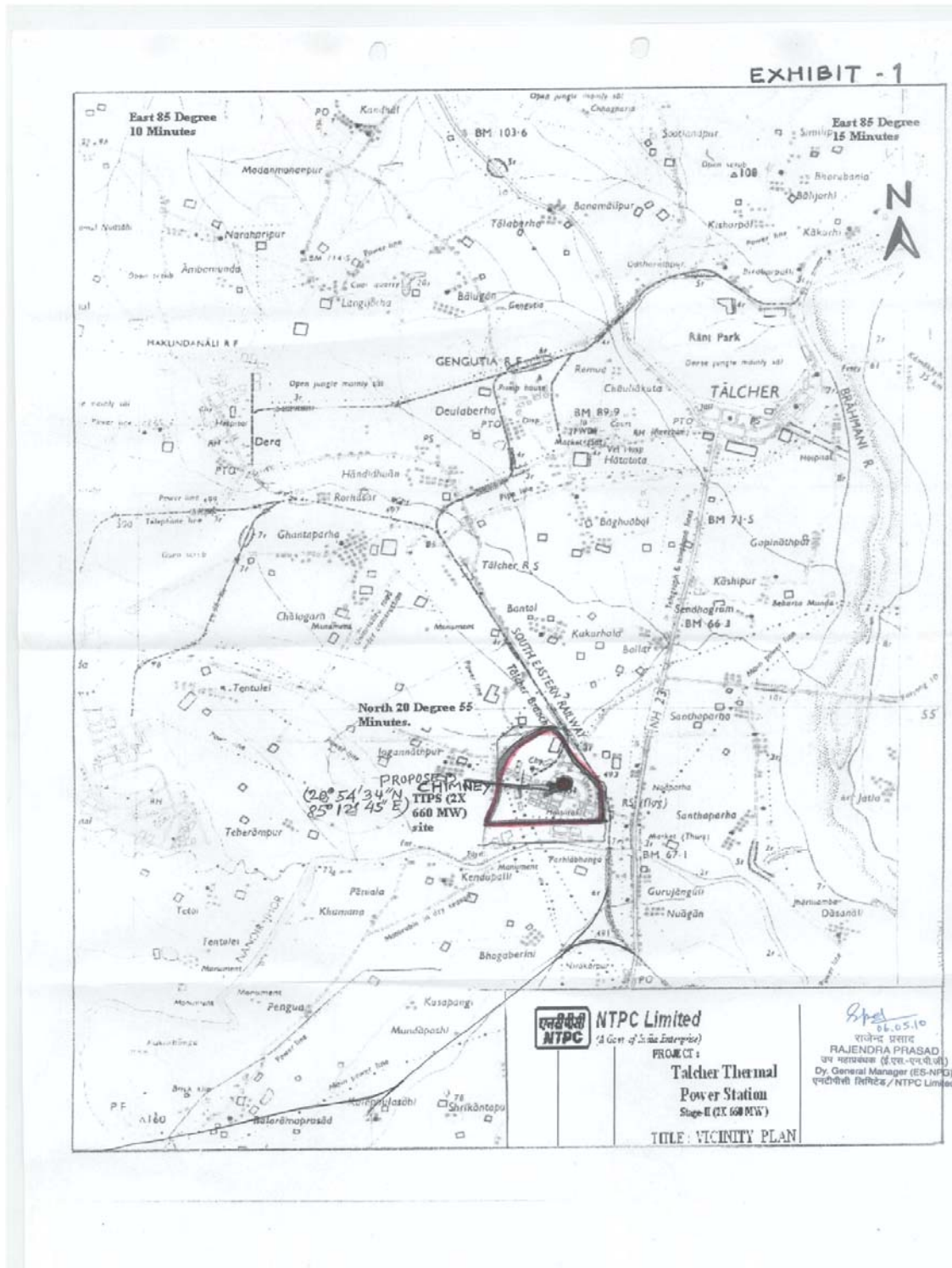

TALCHER THERMAL POWER PROJECT STAGE-III (2X660 MW) EPC PACKAGE	TECHNICAL SPECIFICATION SECTION – VI, PART-A BID DOC. NO CS-4540-001A-2	SUB-SECTION-IB PROJECT INFORMATION	PAGE 4 OF 15
---	--	---	-------------------------------

CLAUSE NO.		PROJECT INFORMATION																									
				ANNEXURE-II																							
<p align="center">जलवायवी साधी CLIMATOLOGICAL TABLE</p> <p align="center">स्टेशन : ANGUI LAT. 20°50' LONG. 85°06' उंची वरून उंची : 139 METRES उंची वरून उंची : 139 METRES उंची वरून उंची : 139 METRES</p>																											
MONTH	STATION PRESSURE (IPA)	MEAN AIR TEMPERATURE						EXTREMES		HUMIDITY		CLOUD AMOUNTS		MOON		WIND		RAINFALL		TOTAL MONTHLY RAINFALL		HEAVEST RAIN IN YEAR		DATE OF HEAVEST RAIN IN YEAR			
		DRY BULB °C	WET BULB °C	DAILY MEAN °C	HIGHEST °C	LOWEST °C	DATE AND YEAR	HIGHEST °C	LOWEST °C	RELATIVE HUMIDITY %	AMOUNT OF CLOUDS	ALL CLOUDS	LOW CLOUDS	NO. OF RAINY DAYS	NO. OF DAYS	NO. OF DAYS	NO. OF DAYS	NO. OF DAYS	NO. OF DAYS	NO. OF DAYS	NO. OF DAYS	NO. OF DAYS	NO. OF DAYS	NO. OF DAYS	NO. OF DAYS	NO. OF DAYS	
JAN	1001.2 997.6	17.9 23.7	15.4 18.5	27.9 15.6	31.0 11.3	35.1 19.4	29 1994	5.5 1971	76 47	15.8 13.6	1.2 1.1	0.3 0.3	9.0 0.7	61.7 1006	0.0 0.0	488 22	22 1905	0.0 0.0	488 22	0.0 0.0	488 22	0.0 0.0	488 22	0.0 0.0	488 22	22 1905	
FEB	1000.1 995.4	21.1 29.0	18.0 19.9	30.0 18.2	33.3 12.7	38.3 19.7	23 1967	8.8 1971	72 41	18.3 16.0	2.0 1.6	1.1 0.9	20.9 1.6	370.1 1061	0.0 0.0	1181 1961	6 6	0.0 0.0	1181 1961	0.0 0.0	1181 1961	0.0 0.0	1181 1961	0.0 0.0	1181 1961	6 6	
MAR	996.7 992.6	25.3 33.5	21.0 22.1	35.5 21.0	38.2 15.9	41.3 19.7	31 1999	10.2 1971	67 35	21.7 17.4	1.5 1.8	0.8 1.1	25.0 1.7	206.0 1990	0.0 0.0	115.0 1990	30 2	0.0 0.0	115.0 1990	0.0 0.0	115.0 1990	0.0 0.0	115.0 1990	0.0 0.0	115.0 1990	30 2	
APR	993.1 988.4	28.7 35.6	24.4 24.4	38.9 24.4	42.5 20.0	45.6 19.1	2 1941	14.4 1971	70 38	27.3 21.5	1.7 2.6	0.7 1.6	35.9 2.3	132.4 1097	0.0 0.0	67.2 1065	2 2	0.0 0.0	67.2 1065	0.0 0.0	67.2 1065	0.0 0.0	67.2 1065	0.0 0.0	67.2 1065	2 2	
MAY	990.4 995.7	30.6 36.6	25.9 25.7	39.8 25.0	44.3 21.6	47.2 19.2	24 1964	15.6 1967	68 42	20.7 20.2	1.9 3.2	0.9 2.0	75.6 3.6	333.1 1095	0.0 0.0	106.0 1990	30 15	0.0 0.0	106.0 1990	0.0 0.0	106.0 1990	0.0 0.0	106.0 1990	0.0 0.0	106.0 1990	30 15	
JUN	985.8 982.5	29.7 32.8	26.0 26.3	36.2 25.9	42.5 21.7	47.2 19.7	15 1967	17.4 1964	74 62	30.7 29.0	4.3 5.1	2.8 3.7	210.1 8.5	528.2 1990	30.4 1990	161.2 1990	15 15	0.0 0.0	528.2 1990	30.4 1990	161.2 1990	0.0 0.0	528.2 1990	30.4 1990	161.2 1990	15 15	
JUL	986.1 983.1	27.9 30.4	25.4 25.9	32.1 24.4	35.2 22.4	41.1 19.2	3 1982	18.3 1971	81 76	30.5 30.7	5.4 5.0	3.6 4.6	250.3 12.1	532.5 1992	102.4 1985	243.9 1992	35 1992	0.0 0.0	532.5 1992	102.4 1985	243.9 1992	0.0 0.0	532.5 1992	102.4 1985	243.9 1992	35 1992	
AUG	986.5 983.9	27.5 28.8	25.3 25.8	31.4 23.9	34.5 21.3	37.7 19.3	22 1983	14.3 1974	83 78	30.6 31.1	5.5 5.9	4.0 4.6	325.3 13.4	805.0 1991	95.5 1997	257.3 1991	21 1991	0.0 0.0	805.0 1991	95.5 1997	257.3 1991	0.0 0.0	805.0 1991	95.5 1997	257.3 1991	21 1991	
SEP	990.9 987.8	27.5 28.9	25.2 25.6	32.1 24.1	34.8 20.5	38.1 19.7	7 1977	12.8 1974	83 76	30.5 30.3	4.5 5.3	3.1 4.0	206.5 10.2	569.7 1921	56.1 1919	148.8 1939	6 1939	0.0 0.0	569.7 1921	56.1 1919	148.8 1939	0.0 0.0	569.7 1921	56.1 1919	148.8 1939	6 1939	
OCT	993.6 992.1	26.2 29.3	23.6 24.3	32.3 20.7	34.4 18.6	37.7 20.0	21 2000	12.0 1974	80 66	27.2 26.5	2.9 3.3	1.7 2.3	100.8 5.1	404.5 1973	0.0 0.0	194.2 1999	18 1999	0.0 0.0	404.5 1973	0.0 0.0	194.2 1999	0.0 0.0	404.5 1973	0.0 0.0	194.2 1999	18 1999	
NOV	990.4 993.8	22.4 27.3	19.4 20.9	30.0 18.2	32.5 13.6	35.1 19.7	26 1997	5.6 1970	75 54	20.5 19.7	1.8 1.9	0.9 1.0	26.7 1.3	161.5 1990	0.0 0.0	101.4 1990	6 1990	0.0 0.0	161.5 1990	0.0 0.0	101.4 1990	0.0 0.0	161.5 1990	0.0 0.0	101.4 1990	6 1990	
DEC	1001.7 997.8	17.8 24.7	15.3 17.9	27.7 15.1	30.3 11.5	35.1 19.5	23 1995	3.5 1974	75 49	15.5 15.3	1.0 1.1	0.4 0.4	3.1 0.3	39.8 1991	0.0 0.0	48.8 1997	14 1997	0.0 0.0	39.8 1991	0.0 0.0	48.8 1997	0.0 0.0	39.8 1991	0.0 0.0	48.8 1997	14 1997	
ANNUAL TOTAL OR MEAN	993.8 990.2	25.2 30.1	22.0 23.1	32.9 23.1	44.1 23.1	47.2 19.4	24 1974	3.5 1974	75 56	24.9 23.2	2.8 3.3	1.7 2.2	130.1 30	2603.4 94	756.1 94	257.3 100	21 100	0.0 0.0	2603.4 94	756.1 94	257.3 100	0.0 0.0	2603.4 94	756.1 94	257.3 100	21 100	
NUMBER OF YEARS	26	18	18	17	17	17	89	89	18	18	26	26	30	30	94	94	100										

CLAUSE NO.	TECHNICAL REQUIREMENTS		
D-1-12(D)	<p style="text-align: right;">Annexure- (D)</p> <p>CRITERIA FOR WIND RESISTANT DESIGN OF STRUCTURES AND EQUIPMENT</p> <p>All structures shall be designed for wind forces in accordance with IS:875 (Part-3) and as specified in this document. See Annexure – I for site specific information.</p> <p>Along wind forces shall generally be computed by the Peak (i.e. 3 second gust) Wind Speed method as defined in the standard.</p> <p>Along wind forces on slender and wind sensitive structures and structural elements shall also be computed, for dynamic effects, using the Gust Factor or Gust Effectiveness Factor Method as defined in the standard. The structures shall be designed for the higher of the forces obtained from Gust Factor method and the Peak Wind Speed method.</p> <p>Analysis for dynamic effects of wind must be undertaken for any structure which has a height to minimum lateral dimension ratio greater than “5” and/or if the fundamental frequency of the structure is less than 1 Hz.</p> <p>Susceptibility of structures to across-wind forces, galloping, flutter, ovaling etc. should be examined and designed/detailed accordingly following the recommendations of IS:875(Part-3) and other relevant Indian standards.</p> <p>It should be estimated if size and relative position of other structures are likely to enhance the wind loading on the structure under consideration. Enhancement factor, if necessary, shall suitably be estimated and applied to the wind loading to account for the interference effects.</p> <p>Damping in Structures</p> <p>The damping factor (as a percentage of critical damping) to be adopted shall not be more than as indicated below for:</p> <p>a) Welded steel structures : 1.0%</p> <p>b) Bolted steel structures/ RCC structures : 2.0%</p> <p>c) Prestressed concrete structures : 1.6%</p> <p>d) Steel stacks : As per IS: 6533 & CICIND Model Code whichever is more critical.</p>		
<p style="text-align: center;">TALCHER THERMAL POWER PROJECT STAGE-III (2X660 MW) EPC PACKAGE</p>	<p style="text-align: center;">TECHNICAL SPECIFICATIONS SECTION-VI, PART-B BID DOC NO.: CS-4540-001A-2</p>	<p style="text-align: center;">SUB-SECTION-D-1-12(D) CIVIL WORKS WIND DESIGN CRITERIA</p>	<p style="text-align: center;">PAGE 1 OF 2</p>

CLAUSE NO.	TECHNICAL REQUIREMENTS		
	<p style="text-align: right;">ANNEXURE-I</p> <p><u>SITE SPECIFIC DESIGN PARAMETERS</u></p> <p>The various design parameters, as defined in IS: 875 (Part-3), to be adopted for the project site shall be as follows:</p> <p>a) The basic wind speed “V_b” at ten metres above the mean ground level : 50 metres/second</p> <p>b) The risk coefficient “K_1” : 1.08</p> <p>c) Category of terrain : Category-2</p>		
<p style="text-align: center;">TALCHER THERMAL POWER PROJECT STAGE-III (2X660 MW) EPC PACKAGE</p>	<p style="text-align: center;">TECHNICAL SPECIFICATIONS SECTION-VI, PART-B BID DOC NO.: CS-4540-001A-2</p>	<p style="text-align: center;">SUB-SECTION-D-1-12(D) CIVIL WORKS WIND DESIGN CRITERIA</p>	<p style="text-align: center;">PAGE 2 OF 2</p>

	TITLE	SPECIFICATION NO. PE-TS-497-501-A501	
	2x660MW TALCHER TPP STAGE-III	REV 00	
	DOUBLE GIRDER EOT CRANES ABOVE 100T	Section IA	Date DEC'22
	SPECIFIC TECHNICAL REQUIREMENTS		

1.0.0. SCOPE OF WORK

1.1.0. SCOPE OF SUPPLY

1.1.1. Equipment and services to be furnished by the bidder for the Two (2) nos. 200T/25T capacity double girder EOT Cranes working in tandem with lifting beam for TG Hall with accessories as per the details given in the technical specification and data sheet A. Any equipment / accessories not specified in the specification but required to make the EOT crane complete for efficient operation shall also be under the bidder's scope of work.

1.1.2. Compliance with this specification shall not relieve the bidder of the responsibility of furnishing material and workmanship to meet the specified working/duty conditions.

1.1.3. Crane shall include but not be limited to the following: -

- a. Bridge girders
- b. End carriages with wheels
- c. Crab (trolley)
- d. Cross Travel & Long Travel drive arrangement
- e. All electrical equipment including cables, junction box, VVVF drive, RRC & pendent and panels etc. as per datasheet A.
- f. PVC insulated shrouded bus bar conductor type DSL
- g. Earthing arrangement
- h. Centralized grease lubrication system to be provided with hand pumps located at crab and both end carriages for all grease lubricated bearings of crane. Tubing/connectors shall be of SS/CS/MS material.
- i. Fill of lubricants till handing over.
- j. Painting of cranes and accessories including touch up painting at site.
- k. Two (2) nos. 3.5 Core Power copper flexible cable (length- Half the bay length + 25m) of suitable size as per load calculation for commissioning, testing & operation of EOT Crane till such time the DSL is charged.
- l. Rail including all accessories and end stopper
- m. Maintenance tools & Tackle
- n. Erection & Commissioning spares
- o. Mandatory Spares
- p. Operator's cabin.

	TITLE	SPECIFICATION NO. PE-TS-497-501-A501	
	2x660MW TALCHER TPP STAGE-III	REV 00	
	DOUBLE GIRDER EOT CRANES ABOVE 100T	Section IA	Date DEC'22
	SPECIFIC TECHNICAL REQUIREMENTS		

- q. Main Isolating switch/Changeover in enclosure at operating floor for disconnecting supply to DSL. Termination of incoming cable (from BHEL) into isolating switch shall be in Vendor's scope. For maintenance of cranes, 2 nos. isolating switches are to be provided at extreme ends of bay.
- r. Slings and cradle for load testing on returnable basis
- s. Lifting beam & endless slings
- t. Storm brake (Hydraulic rail clamp) (2 nos. per crane)

1.1.4 Maintenance Tools and Tackles

As per Annexure III, section-IA of this specification

1.1.5 Mandatory Spares

A complete unused and new set of Mandatory Spare parts shall be supplied. Each part shall be stamped so as to be identified, easy for its use. The items supplied shall be of the best quality. The minimum requirement of mandatory spare parts is listed in Annexure –II section-IA of this specification.

1.1.6 Erection and Commissioning spares

The Bidder shall also supply erection & commissioning spares along with his main equipment as per his experience, for replacement of damaged or unserviceable parts during the execution of the project at site, to avoid delay in the project schedule. This shall form part of the main equipment supply. The Purchaser shall retain the unutilized commissioning spares. Fill of lubricants; oil etc. till commissioning of the cranes shall also be supplied by the bidder.

1.1.7 Any supplies/services mentioned in GCC, SCC as relevant to the package

1.2.0 Services to be provided by the bidder

1.2.1. Packing, forwarding and transportation to site

1.2.2. Development of storage space including ward & watch of the equipment and handling at site.

1.2.3 Unloading, storage and handling at site.

The Bidder shall provide means for all unloading and reloading for all consignments of plant; both during transport to Site and on the Site. Consignments shall be unloaded

	TITLE	SPECIFICATION NO. PE-TS-497-501-A501	
	2x660MW TALCHER TPP STAGE-III	REV 00	
	DOUBLE GIRDER EOT CRANES ABOVE 100T	Section IA	Date DEC'22
	SPECIFIC TECHNICAL REQUIREMENTS		

immediately on arrival at Site. The Bidder is required to take the necessary steps in order to provide the carriage, special supporting structures for heavy loads, etc. The following parts shall be stored inside enclosed warehouses:

Bolts, pins, packing, tools, insulation materials, electrical parts with electrical devices attached, electric motors and excitation equipment, instruments, welding material and equipment, all small parts and all parts of the crane which already have been finally painted. If large parts are stored in the open air, they shall be provided with weather resistant and fire & resistant covers. Electrical parts, which are not packed in heavy duty polyethylene foil and those so packed, but whose packing has been damaged shall be kept in suitable places from the moment of storage to the moment of installation. All insulation materials which will be taken from the warehouse for installation and which are stored temporarily in the station shall be protected from weather or humidity. All the equipment shall be stored as per standard storage and preservation instructions etc. of the suppliers.

1.2.4 Arranging test load at site

Collecting the test load at site within a radius of 1-2 KM from owner's storage to final testing bed of crane shall be under bidder's scope of work. Test load in the form of rolled steel, plates, girder, angle etc., as available at the site shall be made available by the purchaser. The test load shall be put back to the place from where it was lifted by the vendor, after the load testing. Load testing sling, cradles and any other item required by the vendor during the load testing shall be arranged by the vendor at no extra cost to the purchaser. Slings & cradles will be allowed to be taken back by the vendor, after completion of the test at site.

1.2.5 Erection and Commissioning & E-Learning Package (Annexure-IX)

1.2.6 Demonstration / Load test at bidder's Works and at site.

1.2.7 Obtaining clearance and acceptance certificate from the concerned competent

Authority after site test and as and when required as per Government Norms /Statutory body till the time of final handing over to Customer. Necessary fees/expenditure as required shall be borne by the supplier.

1.2.8 Operation & maintenance for two years of each crane with details as per Annexure A which may be further extended as per requirement to be intimated by BHEL site.

	TITLE	SPECIFICATION NO. PE-TS-497-501-A501	
	2x660MW TALCHER TPP STAGE-III	REV 00	
	DOUBLE GIRDER EOT CRANES ABOVE 100T	Section IA	Date DEC'22
	SPECIFIC TECHNICAL REQUIREMENTS		

However bidder to note that warranty period as per relevant clause of GCC shall start after handling over the cranes to BHEL/customer after completion of O&M services.)

1.2.9 Any service mentioned in GCC & SCC as relevant to the package.

1.3.0. PAINTING & COLOUR SCHEME

As per Annexure IV, section-IA of this specification

2.0.0. Works Excluded

Supply feeder and cable from feeder / MCC to isolating switch.

Gantry girder

Dead load for load/ overload testing at site

Space for storage.

Exclusion, if any, mentioned in GCC, SCC.

3.0.0. Drawing and documents submission schedule along with number of prints.

Drawing and documents submission schedule along with number of prints / copies required for various drawing and documents are listed in Annexure –V, section-IA of this specification.

4.0.0. Deviations

If the offer submitted has got any deviation from the technical stipulations in the tender document, bidder shall tabulate the same in the format of “Cost of withdrawal of deviation” attached in Section III and furnishing full particular of such deviations. Deviations are to be furnished with mention to specific clause number (reasons / explanations for such deviations shall be furnished). Notes / comments etc. is not acceptable. If there are no deviations from the tender document, bidder shall mention “**NO DEVIATION**” in cost of withdrawal of deviation format.

5.0.0. Makes of Sub - Vendor items

Makes of bought out items as per Annexure-I, section IA of the specification is for reference only. Sub vendor list shall be subject to customer approval and same shall not have any impact on manufacturing, delivery schedule and cost of the crane.

	TITLE	SPECIFICATION NO. PE-TS-497-501-A501	
	2x660MW TALCHER TPP STAGE-III	REV 00	
	DOUBLE GIRDER EOT CRANES ABOVE 100T	Section IA	Date DEC'22
	SPECIFIC TECHNICAL REQUIREMENTS		

6.0.0 Parameter and tolerances for structural assembly including rail shall be as per the relevant standards.

7.0.0. Performance Test requirement

EOT crane along with its drives, controls and other accessories shall be checked for the rated capacity against the rated speed of motions and for the service conditions specified.

The bidder shall have the full responsibility for the safe and efficient operation of the crane with associated accessories as a single unit. If the site performance tests indicate the failure of any of the components to achieve the desired performance, the deficiency shall be made good at bidder's cost.

Performance test shall be carried out each time after the rectification /modification is carried out.

Performance test of the crane shall include load tests and speeds in various motions at site.

7.1.0 Testing at site

Completely assembled crane at site shall be check for misalignment of gears, shafts and other items. Following minimum tests shall be conducted on the crane at the site

- i. Deflection test of bridge girder at rated load. Crane shall rest on centerline of LT wheels.
- ii. Load test and Overload test (running of CT and Hoisting mechanism at 125% of the rated load). Capability of crane to lift the overload from mid-air shall be demonstrated. Electrical tests for brakes, panel, electrical equipment etc. as per IS - 3177
- iii. All Other tests as per IS-3177.
- iv. Load & overload test along with deflection test of lifting beam in line with BHEL approved MQP for lifting beam (if applicable).
- v. Speed test at rated load for hoisting, CT and LT mechanism.
- vi. Brake test.
- vii. Any other test as per IS-3177

Note: The test shall be carried out with actual panel, RRC, Master Controller etc.

	TITLE	SPECIFICATION NO. PE-TS-497-501-A501	
	2x660MW TALCHER TPP STAGE-III	REV 00	
	DOUBLE GIRDER EOT CRANES ABOVE 100T	Section IA	Date DEC'22
	SPECIFIC TECHNICAL REQUIREMENTS		

8.0 Consumables

The Bidder's scope includes requirements of consumables such as oils, lubricants including grease, servo fluids, gases and essential chemicals etc. till handing over. Consumption of all these consumables till handing over shall also be included in the scope of the Bidder. Bidder shall also supply a quantity of the full charge of each variety of lubricants, servo fluids, gases, chemicals etc. used which is expected to be utilized till handing over. This additional quantity shall be supplied in separate Containers.

	TITLE	SPECIFICATION NO. PE-TS-497-501-A501
	2x660MW TALCHER TPP STAGE-III	REV 00
	DOUBLE GIRDER EOT CRANES ABOVE 100T	Section IA Date DEC'22
	SPECIFIC TECHNICAL REQUIREMENTS	

OPERATION AND MAINTENANCE SERVICES SHALL INCLUDE BUT NOT LIMITED TO FOLLOWING (FOR TG HALL CRANE ONLY) ANNEXURE A

- 1.0 Scope covers operation and maintenance service including manpower, supervision, consumables etc. for complete operation and maintenance of 2 numbers 200/25T Double Girder Cranes for Power House area for two years after successful erection, commissioning & load testing. The O & M period shall be started after successful load testing at site.
- 2.0 For Operation of the Crane An experienced crane operator or shall be available for each crane as and when required by BHEL for at least 16hrs a day, daily.
- 3.0 For Maintenance of the Crane
 - a) Break-Down Maintenance
 - i) In case of any break-down of the crane during the contract period, service engineer shall be made available at site within 72 hrs.
 - ii) All the critical spares and consumables, as deemed necessary by the manufacturer shall be made available at the site. No delay in crane maintenance shall be allowed by BHEL due to non-availability of required spare at site.
 - b) Preventive Maintenance
 - i) Following work should be carried out quarterly

Bridge and Trolley wheel assembly	Checking for wear, flat spots and cracks in flange. Ensure drive wheels are of the same diameter.
Runway	Checking alignment and elevation of gantry track. Checking rail clamp bolts.
Machine Bolts	Checking all foundation bolts of Electrical and Mechanical equipment for tightness.
Structural Bolts	Checking for tightness. They should also be checked after the first month of operation.
Flexible Couplings	Checking pins and teeth for wear, cleaning and greasing.
Cross-shaft Plummer	Dismantling cap. Cleaning and checking oil seals and to be

	TITLE	SPECIFICATION NO. PE-TS-497-501-A501
	2x660MW TALCHER TPP STAGE-III	REV 00
	DOUBLE GIRDER EOT CRANES ABOVE 100T	Section IA Date DEC'22
	SPECIFIC TECHNICAL REQUIREMENTS	

Blocks	packed with fresh grease.
Trolley Collectors	Checking of cable trolleys / cabling / chain. Ensuring connection of trolley wheels is kept through entire length of span.
Brakes	All Brake assembly will be checked for loose connection, earthing connection, linings for wear, leakages and adjustments to ensure brake is not rubbing the brake drum during operation. Greasing pins and operation adjustment of brakes.
Resistor Connections	Checking, tightening connections at grid joints and at cable terminations.
Control Station	Clean out control cabinets. Checking of all connection at push buttons, master controllers contact tips, cams and terminals.
Control Panels	All Control Panels will be checked for loose connection and cleaning the contactor contacts, if required will be replaced.
Electrical Motors	All motion motors connection will be checked for loose contacts in terminal box loose crimping of wire lugs, loose contacts on slip ring assembly with carbon brush. Earthing connection with motor.
Safety Switches	All limit switches will be checked for desired operation and limits. Emergency switches will be checked.
Main Collectors	Checking of worn collector shoes, sag in main runway wiring, ensuring contact is kept through entire length runway properly.
Electrical connections	Checking throughout electrical equipment for loose connection such as selector switches, junction boxes, min isolator switch etc.
Lubrication	All gear box and thrusters' oil level will be checked. All bearings, couplings' grease will be checked.
Testing	After completion of checking and required rectification, trolley will be checked for idle operation, for brake operation, limit switch operation & safety switch operation. All motor currents will be checked on no load.

	TITLE	SPECIFICATION NO. PE-TS-497-501-A501	
	2x660MW TALCHER TPP STAGE-III	REV 00	
	DOUBLE GIRDER EOT CRANES ABOVE 100T	Section IA	Date DEC'22
	SPECIFIC TECHNICAL REQUIREMENTS		

ii) Following work should be carried out annually

Gear Boxes	Oil seals will be checked, if required will be replaced. Gear and pinion teeth will be checked. Drain the oil cleaning gear box and refill fresh oil.
Motor	All motors' insulation test and meagre test will be carried out.
Resistance Box	All resistance boxes' step resistance value will be checked.

iii) Besides the quarterly and annual preventive maintenance schedule mentioned above, operator shall carry out any daily, weekly, monthly maintenance schedule as deemed necessary and shall operate the crane only when the fitness of the crane for operation has been ensured.

4.0 Bidders' scope of work shall also include, arranging the statutory clearance from the concerned Government body/Authority as and when required for renewal of license till handing over. It shall be bidder's responsibility to ensure the presence of competent authority at the time of testing and obtaining the clearance and acceptance certificate from the concerned authority. Necessary fees/expenditure as required shall be borne by the supplier.



TITLE
2x660MW TALCHER TPP STAGE-III
DOUBLE GIRDER EOT CRANES ABOVE 100T
SPECIFIC TECHNICAL REQUIREMENTS

SPECIFICATION NO. PE-TS-497-501-A501	
REV 00	
Section IA	Date DEC'22

QUALITY ASSURANCE AND INSPECTION REQUIREMENT

	TITLE	SPECIFICATION NO. PE-TS-497-501-A501	
	2x660MW TALCHER TPP STAGE-III	REV 00	
	DOUBLE GIRDER EOT CRANES ABOVE 100T	Section IA	Date DEC'22
	SPECIFIC TECHNICAL REQUIREMENTS		

1.1.0. Inspection and Testing

Bidder shall submit QAP based on the guidelines given in the specification & QAP enclosed therein.

1.1.1. Inspection and testing at Manufacturer's works

Copy of approved documents with stamp and signature (one set) shall be available at the place of Inspection which shall be ensured by supplier.

Shop inspection and tests will include but not limited to the following –

STAGE INSPECTION

Stage inspection of various components of crane shall be guided by the MQP approved during detail engineering. Indicative MQP is attached in the specification. However, following shall be ensured and read in conjunction with relevant clause of MQP w.r.t. stage inspection:

- i. All test certificates shall be in original and legible. Photocopies certified by Mill/ manufacturer of raw material used, are acceptable.
- ii. For tensile testing of hooks/ forgings, samples shall be drawn from the full cross section of the shank diameter of hooks/ forgings Samples forged to reduced cross section for testing purposes is not acceptable. **Hooks shall be manufactured from Blooms, billets, rounds by forging with forging ratio of at least 3:1. Hooks manufactured from plates are not acceptable.**
- iii Radiographs shall be inspected to a sensitivity of 2%.
- iv Ultrasonic test on forgings and casting of critical components like cross head (hook suspension block), Hooks, Shafts, Axles, Gears, Wheels, Pulleys etc. Ultrasonic test on forgings shall be carried out as per norms given below. UT shall be carried out in Proof machined condition (single diameter/ Flat surface without steps, keyways, teeth cutting or other profile machining which can create difficulty in ultrasonic testing). Components shall be identified with Heat number and serial number by punching). Hardening operation shall be carried out prior to Ultrasonic testing. Unacceptable defects in forgings are as given below:

1. Cracks, flakes, seams and laps

	TITLE	SPECIFICATION NO. PE-TS-497-501-A501	
	2x660MW TALCHER TPP STAGE-III	REV 00	
	DOUBLE GIRDER EOT CRANES ABOVE 100T	Section IA	Date DEC'22
	SPECIFIC TECHNICAL REQUIREMENTS		

2. Defects giving indication larger than '4 (four) mm diameter equivalent flaw' except for wheels for which Defects giving indication larger than '6 (six) mm diameter equivalent flaw.'
3. Group of defects with maximum indication less than that from a 4 mm diameter equivalent flaw which cannot be separated at testing sensitivity if the back echo is reduced by 50% except for wheels for which Group of defects with maximum indication less than that from a 6 mm dia. equivalent flaw which cannot be separated at testing sensitivity if the back echo is reduced by 40%.
4. Defects giving indication of 2 to 4 mm dia. equivalent flaw, separated by a distance less than 4 (four) times the size of the larger of the adjacent flaws except for wheels for which Defects giving indication of 3 to 6 mm dia. Equivalent flaw, separated by a distance less than 4 (four) times the size of the larger of the adjacent flaws Ultrasonic test on Castings shall be carried out as per ASTM E 609.

Wherever, the Quality plan calls for witness of Ultrasonic test by BHEL or BHEL's representative, the material shall be offered for UT in proof machined condition as stated above and hard stamping and subsequent stamp transferring by BHEL shall be followed at subsequent stages to ensure trace ability.

- v. Gear boxes shall be checked at No load for backlash, tooth contact, noise, temperature rise and vibration as per attached Procedure No. PEM (Q)/001.
- vi. Test certificates shall be furnished for verification of Type tests including environmental tests - for electrical and electro-mechanical items. If Type tests for items with similar / identical construction are not available, arrangement shall be made to conduct the same in the presence of BHEL/ Customer's representative (as required).
- vii. Acceptance and routine tests (HV and insulation) for all electrical and electro-mechanical components and system as per governing specification

FINAL INSPECTION- Testing At Works.

Cranes shall be completely assembled at manufacturer's works to check the misalignment of gears, shafts and other items. Gears shall be run idle for at least 4 (four) hours. Following minimum tests shall be conducted on the crane at the works of the manufacturer:

	TITLE	SPECIFICATION NO. PE-TS-497-501-A501	
	2x660MW TALCHER TPP STAGE-III	REV 00	
	DOUBLE GIRDER EOT CRANES ABOVE 100T	Section IA	Date DEC'22
	SPECIFIC TECHNICAL REQUIREMENTS		

- a) Deflection test of bridge girder at rated load. Crane shall rest on centerline of LT wheels.
- b) Load test and Overload test (running of CT and Hoisting mechanism at 125% of the rated load). Capability of crane to lift the overload from mid-air shall be demonstrated.
- c) Electrical tests for brakes, panel, electrical equipment etc. as per IS - 3177
- d) All Other tests as per IS-3177.

Procedure for Load/Overload testing of EOT cranes at Manufacturer's Works & Site

Refer Testing requirement as mentioned at ANNEXURE-VII.

Load testing procedure of lifting beam at Works:

1) Scope: This covers the guidelines for load testing of lifting beams of EOT cranes.

2) ACCESSORIES AND FACILITIES NEEDED:

- a) Slings of suitable size and length, proof load tested at 2 X Safe working load (SWL)
- b) Jacking system/ any other mechanism
- c) Supporting structure
- d) Test loads.
- e) Cradle for accommodating test load (if required).

3) PROCEDURE:

- a) Support the lifting beam on fabricated structure and hydraulic jacks at both ends as indicated in the attached sketch no LB/001.
- b) Place the load to be lifted under the lower lifting beam. Total test load shall be 1.25 times the SWL
- c) Drop the lifting slings from the lifting beam and safely tie it with the load.
- d) The sling should be tied with the lifting beam such that the slings should not be slack. This should ensure that the slings are in full tension when the lifting beam is elevated by at least 100mm
- e) Fix the necessary measuring instrument in the lifting beam with wire and plumb to measure the initial reading for vertical deflection of both lower and upper lifting beam.

	TITLE	SPECIFICATION NO. PE-TS-497-501-A501	
	2x660MW TALCHER TPP STAGE-III	REV 00	
	DOUBLE GIRDER EOT CRANES ABOVE 100T	Section IA	Date DEC'22
	SPECIFIC TECHNICAL REQUIREMENTS		

- f) Now elevate the lifting beam by means of hydraulic jacks, such that the lifting beam is elevated by at least 100mm.
- g) Ensure that the whole load is lifted clear from the floor.
- h) Ensure that the elevation is equal at both ends.
- i) Now the load is lifted by 100 mm and hence the sling is in full tension.
- j) Keep the load in lifted condition for one minute.
- k) Measure the deflection of the lifting beam structure.
- l) Bring down the lifting beam to its original position with the help of jack.
- m) Make the lifting beam free from testing position and put in safe place.
- n) Visually check the weldments of lifting beam and carryout DP test in case of doubt.

4) REMARKS:

The dimensions of stand, cradle etc. in sketch no LB/001 are illustrative only. Bidder to make suitable arrangement as per their shop facility. In case the bidder has test pit facility instead of stands (illustrated in sketch LB/001), the same can also be used.

	TITLE	SPECIFICATION NO. PE-TS-497-501-A501
	2x660MW TALCHER TPP STAGE-III	REV 00
	DOUBLE GIRDER EOT CRANES ABOVE 100T	Section IA
	SPECIFIC TECHNICAL REQUIREMENTS	Date DEC'22

Procedure No. PEM (Q)/001

SHOP TEST PROCEDURE FOR GEAR BOX

1.0.0	Scope: Acceptance Norms for Crane Gear Boxes
1.1.0	This procedure lays down the Acceptance norms for the Gear boxes for EOT crane. This standard also covers vertical gear boxes. Reduction Gears shall be tested for reduction ratio, backlash & contact pattern. Gear Box shall also be subjected to No load run test to check for oil leakage, temp. rise, noise and vibration.
2.0.0	The following dimensions shall be checked:
2.1.0	i. Diameter and keyway dimensions of input and output shafts. ii. Projection of input and output shafts beyond foundation holes and Centre lines of gear box. iii. Centre distance between input and output shafts. iv. Centre Height. v. Distance between foundation holes with respect to center line of the output shaft and distance of foundation holes from center line of the gearbox. vi. Overall dimensions
3.0.0	Backlash
3.1.0	The back lash shall be checked by dial gauge preferably (refer Figure –1). Lead wire may be also be used but final decision in case of dispute shall be taken by using dial gauge. The backlash shall be within the limits specified in the drawing. If the value of the backlash allowed is not specified in the drawing, the allowed backlash shall be a given in Table-1
4.0.0	Area of Contact:
4.1.0	Area of contact shall be taken by applying Prussian blue. The contact area shall be within the limits mentioned below (refer Figure –2) For final stage of Hoist gearing: h / H shall be more than 30% $(a - c) / b$ shall be more than 40% For all other gears: h / H shall be more than 40% $(a - c) / b$ shall be more than 50%
5.0.0	Running Test
5.1.0	The gear boxes shall be run under no-load condition at the rated speed for minimum four hours in each direction and the following are to be checked:

	TITLE	SPECIFICATION NO. PE-TS-497-501-A501	
	2x660MW TALCHER TPP STAGE-III	REV 00	
	DOUBLE GIRDER EOT CRANES ABOVE 100T SPECIFIC TECHNICAL REQUIREMENTS	Section IA	Date DEC'22

	<ul style="list-style-type: none"> i. All bolts at the joints remain tight ii. All gear mesh lines are getting enough lubrication iii. All bearings are getting enough lubrication iv. Bearing temperatures after running for four hours shall not exceed 50 deg. Centigrade or 15 deg. centigrade above ambient whichever is higher. Temperature shall be checked after every hour. v. Vibration : Maximum limit 125 microns (peak to peak) vi. Sound: The gearbox shall not emit unusual sound as obtained under conditions of hard meshing, high spots etc. Maximum sound level shall be 85 dBA at a distance of 1000mm and 91 dBA at a distance of 300 mm. vii. There shall be no Oil leakage at parting lines, bearing housings or inspection covers.
6.0.0	General
6.1.0	<p>In addition to the above specific points, the following general points shall be ensured:</p> <ul style="list-style-type: none"> i. Inspection pockets are provided as required. ii. Gear box casings are provided with at least two fit bolts/dowels at the parting line. iii. Dip sticks with minimum / maximum level markings are provided. iv. Drain plugs are provided at convenient locations preferably at vertical wall of the housing. v. Breathers are provided. vi. Lifting lugs or eye bolts are provided as required. vii. Wherever bearings have splash lubrication, oil retainers are provided. viii. Gear boxes are painted as per specification outside and inside. Inside surfaces shall be painted with Oil proof paint. ix. In case of vertical gear boxes having more than two stage reduction, forced lubrication is also provided. <p>Name plate should provide information eg. Ratio, KW rating, Bearing details and manufacturers name.</p>



TITLE

2x660MW TALCHER TPP STAGE-III

DOUBLE GIRDER EOT CRANES ABOVE 100T
SPECIFIC TECHNICAL REQUIREMENTS

SPECIFICATION NO. PE-TS-497-501-A501

REV 00

Section IA

Date DEC'22

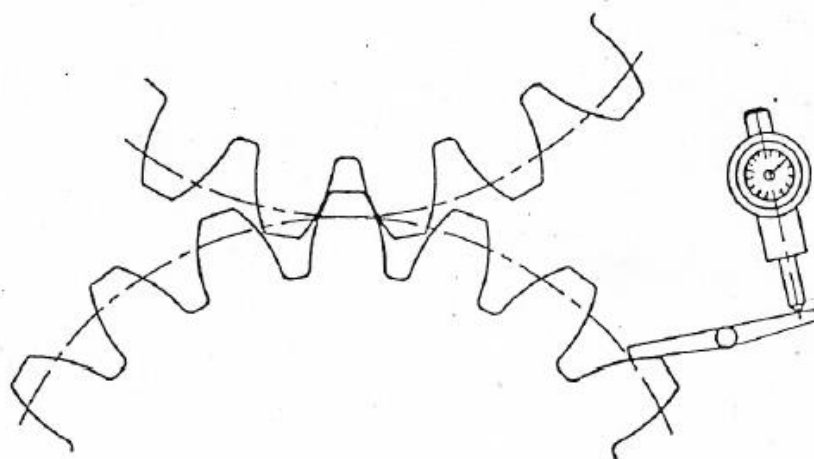

FIG.1 MEASUREMENT OF BACKLASH

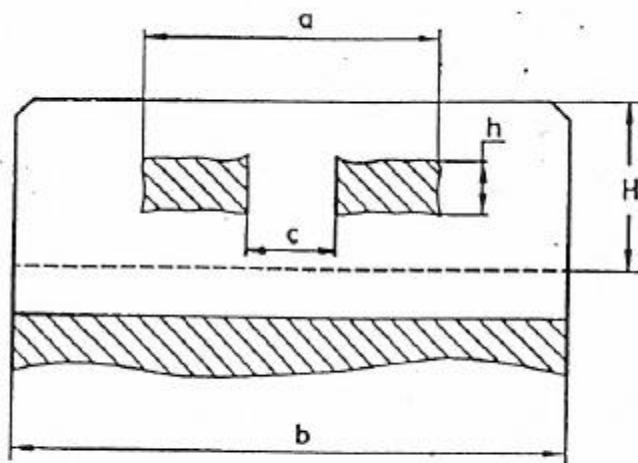

FIG.2 AREA OF CONTACT OF GEAR TEETH



TITLE

2x660MW TALCHER TPP STAGE-III

DOUBLE GIRDER EOT CRANES ABOVE 100T
SPECIFIC TECHNICAL REQUIREMENTS

SPECIFICATION NO. PE-TS-497-501-A501

REV 00

Section IA

Date DEC'22

Table-1

Backlash for Gearing specified by module
(Clause 3.1.0)

Centre distance in mm		Tolerances in microns		
Above	Upto	Minimum	Maximum	
			For gears other than Drum gears	For Drum gears
			For all modules 1 to 50	For all modules 2.5 to 50
-	50	85	240	280
50	80	105	320	380
80	120	130	360	420
120	200	170	470	530
200	320	210	540	640
320	500	260	660	740
500	800	340	820	880
800	1250	420	970	1040
1250	2000	530	1200	1280
2000	3150	710	1500	1670
3150	5000	850	1810	1980





TITLE
3X800 MW PATRATU STP
DOUBLE GIRDER EOT CRANES ABOVE 100T
SPECIFIC TECHNICAL REQUIREMENTS

SPECIFICATION NO. PE-TS-497-501-A501
REV 00
Section IA Date DEC'22
Page 1 of 28

SECTION – IA
CUSTOMER SPECIFICATION

CLAUSE NO.	TECHNICAL REQUIREMENTS		
6.05.10 6.05.11	<p>STRAINERS AT BOOSTER PUMP AND BOILER FEED PUMP Strainer body simplex and cylindrical type. The clear area of strainer to be Five times the inlet cross sectional area of the connecting piping. Strainer to be constructed of 11 gauge perforated stainless steel (304 grade) and lined with stainless steel (316 grade) screen. At design flow and clean condition, Pressure drop not to exceed 0.15 Kg/cm². At design flow and 50% clogged condition, Pressure drop not to exceed 0.20 kg/cm².</p> <p>Type Test(s) to be conducted Following type tests to be carried out;</p> <ul style="list-style-type: none"> (i) NPSH (R) Test on one BFP and one BP (ii) Pressure pulsation test on one BFP (iii) Axial thrust measurement on one BFP (iv) Visual cavitation test on one BFP (v) Complete strip down test of BFP which undergone above tests (vi) Pressure drop test on one strainer for each type and size <p>Bidder to ensure that after the type test, the pump is properly cleaned and dried so that during transportation there is no damage/rusting in the pump.</p>		
7.00.00 7.01.00	<p>EOT CRANES</p> <p>TURBINE HALL EOT CRANE:</p> <p>(i) RATING</p> <ul style="list-style-type: none"> (a) Capacity AS specified elsewhere in specification (b) Auxiliary Hoist Capacity Not less than 20 Tonne (c) Total height of crane Top most level of crane w.r.t. the top of runway rail level shall be approximately 4.5m (d) Approximate max. full load speeds <ul style="list-style-type: none"> - Main Hoist 1.6 m/min - Auxiliary Hoist 7.5 m/min. - Trolley travel 15.0 m/min. - Crane travel 30.0 m/min. (e) Creep speed of main hook and auxiliary hook 10% of max. speed (f) Creep speed for cross travel and long travel 10% of the maximum speed <p>(ii) Applicable codes</p> <ul style="list-style-type: none"> (a) Design and duty of crane structure, main hoist, auxiliary hoist, cross travel, long travel in accordance with class M5 of IS: 3177 (latest edition). (b) All other structure of cranes in accordance with IS-807. (c) Main hook Ramshorn type conforming to IS-5749 (latest edition) and auxiliary hook shank type conforming to IS 15560 (latest edition) <p>In case the load is more than 250 Tonne, Main hook (Ramshorn type) shall conform to DIN-15402 (latest edition).</p>		
TALCHER THERMAL POWER PROJECT STAGE-III (2X660 MW) EPC PACKAGE	TECHNICAL SPECIFICATION SECTION-VI, PART-B BID DOC. NO.: CS-4540-001A-2	SUB SECTION-A-07 STEAM TURBINE AND AUXILIARIES SYSTEM	PAGE 16 OF 25

CLAUSE NO.	TECHNICAL REQUIREMENTS		
	<p>(iii) Bridge structure</p> <p>(a) Vertical deflection caused by safe working load and weight of trolley in central position not to exceed 1/900 of the span.</p> <p>(b) Trolley stops of spring type to be mounted independently on bridge rails to prevent trolley from running off.</p> <p>(iv) Buffer</p> <p>(a) Suitable buffer to be fitted to each end of carriage assembly and crab.</p> <p>(b) Buffers to be designed to bring the loaded crane to rest from a speed of 50% of the rated speed.</p> <p>(v) End trucks, wheels and axles To be designed in accordance to IS: 3177 (latest edition)</p> <p>(vi) Bridge and trolley drive Mechanism</p> <p>(a) One drive at each end of bridge.</p> <p>(b) One drive for trolley drive.</p> <p>(vii) Operator's cabin and platform</p> <p>(a) Open type for indoor service to be located at B-row column. Cabin shall be designed as per IS3177 so as to have unrestrictive view of load from operator's cabin.</p> <p>(b) The area of cabin to be 2500/1850 mm with a head room of 2000 mm.</p> <p>(c) A foot operated electric warning horn of double bell type suitable for 240 V AC. of noise level 95 dBA at 3.5 m.</p> <p>(d) One brass gong suspended outside the Cabin and operated from inside.</p> <p>(e) A distinct type alarm with conspicuous warning lights on either side of the crane bridge to indicate overloading of crane.</p> <p>(f) Adequate carbon dioxide gas cylinders of 4.5 Kg.</p> <p>(g) One non oscillating ventilating fan.</p> <p>(h) Suitable inspection cages to accommodate two persons to facilitate inspection of down shop lead.</p> <p>(i) Access walkways of not less than 800 mm (clear) with hand railing of height of 1100 mm along the both side of bridge girder and cross over walkways</p> <p>(viii) Drums To be in accordance with IS-3177 (latest edition).</p> <p>(ix) Wire Rope</p> <p>(a) Wire rope of extra flexible plough steel and of 6/36 or 6/37 construction conforming to IS: 2266 (latest edition)</p> <p>(x) Bearings and lubrication</p> <p>(a) The type of bearings for various parts as per IS:3177 (latest).</p> <p>(b) Bearing life not less than 10,000 working hours.</p> <p>(c) Centralised grease lubrication with hand operated grease pump for all bearings as per bidder's standard proven practice.</p> <p>(xi) Guarding</p> <p>(a) Suitable guard to push forward or off the rail track any object placed across.</p> <p>(b) Suitable guards to live electrical wirings downshop lead.</p> <p>(c) Other guarding as per relevant standard.</p>		
<p>TALCHER THERMAL POWER PROJECT STAGE-III (2X660 MW) EPC PACKAGE</p>	<p>TECHNICAL SPECIFICATION SECTION-VI, PART-B BID DOC. NO.: CS-4540-001A-2</p>	<p>SUB SECTION-A-07 STEAM TURBINE AND AUXILIARIES SYSTEM</p>	<p>PAGE 17 OF 25</p>

CLAUSE NO.	TECHNICAL REQUIREMENTS											
	<p>(xiii) Safety</p> <p>(a) Suitable anti-collision device of two cranes, alongwith stoppers at both the gable ends.</p> <p>(b) To meet the requirements of Factories Act.</p> <p>(xiv) Runway/trolley Rails and rail joints Rails to be as per relevant Indian Standard and joints to be butt welded by thermit welding or fusion welding.</p> <p>(xv) Brakes 2 X 100 % Brake shall be provided for each motion. Each brake for hoisting motion, cross travel, long travel etc., shall be designed as per following: Brakes to be as per IS 3177. The Capacity of hoisting motion brakes to be 150% of torque transmitted to the brake drum with full load and that of cross travel and long travel to be 125% of motor rated torque before deaerating.</p> <p>xvi) Storm Brakes: 2x50% storm brakes, one each at each end of the bridge, shall be provided for each crane. Storm brakes shall be designed for wind velocity as indicated in "Criteria for wind resistant design for structure and equipment", Sub-section – D-01 / Civil Works/ Part-B/ Section-VI.</p> <p>(xvi) Common lifting beam for generator stator</p> <p>a) Suitable common lifting beam for lifting generator stator by means of two cranes operating in conjunction with suitable swiveling arrangement.</p> <p>b) A suitable indicating device to indicate the difference in the lifts of the two cranes, which shall be limited to 500 mm shall be provided on the lifting beam. The level difference indication shall be visible from ground level.</p> <p>c) A limit switch shall be provided to give alarm at both the cabins to enable the crane operators to control the level difference within 500mm.</p> <p>The bidder shall furnish the GA drawing of the beam showing all the dimensions, constructional details, details of crane hooks connection to the beam, lifting arrangement, level difference indicating devices, etc alongwith the bid.</p>											
7.02.00	EOT CRANES FOR BOILER FEED PUMP (if envisaged)											
7.02.01	One (1) no of Electrically operated travelling cranes (Double Girder type) for each unit with associated auxiliaries, alongwith electrical equipment, control & instrumentation as required and specified shall be provided in the BC bay for erection and maintenance of Boiler feed pump and their auxiliaries. The capacity of each crane shall be 10% over and above the heaviest component equipment to be handled (including lifting beam and slings etc., if provided) or 25 Tonne whichever is higher.											
7.02.02	The EOT crane shall be pendant operated. The power shall be supplied from a single electrical power supply point at a suitable location on the operation floor of pump house.											
7.02.03	The design code for EOT crane shall be IS: 3177 latest edition.											
7.02.04	However, the speed for the various motions shall be as follows:											
	<table border="0"> <tr> <td>Main hoist</td> <td>-</td> <td>1.6 m/min</td> </tr> <tr> <td>Trolley Travel (Cross Travel)</td> <td>-</td> <td>4.0 m/min</td> </tr> <tr> <td>Crane Travel (Long Travel)</td> <td>-</td> <td>8.0 m/min</td> </tr> </table>			Main hoist	-	1.6 m/min	Trolley Travel (Cross Travel)	-	4.0 m/min	Crane Travel (Long Travel)	-	8.0 m/min
Main hoist	-	1.6 m/min										
Trolley Travel (Cross Travel)	-	4.0 m/min										
Crane Travel (Long Travel)	-	8.0 m/min										
7.02.05	Creep speed drives shall be provided for all the motions viz. bridge motion, trolley motion and hoist motion. This shall be 10% of the rated speeds. (Creep speed to be achieved through pony motor and planetary gear box or through variable voltage variable frequency (VVVF) system. Hoist brake shall not be used for this motion).											
TALCHER THERMAL POWER PROJECT STAGE-III (2X660 MW) EPC PACKAGE	TECHNICAL SPECIFICATION SECTION-VI, PART-B BID DOC. NO.: CS-4540-001A-2	SUB SECTION-A-07 STEAM TURBINE AND AUXILIARIES SYSTEM	PAGE 18 OF 25									

CLAUSE NO.	TECHNICAL REQUIREMENTS	
7.02.06	The crane shall be electrically operated, overhead travelling type. Design and duty of crane structure, main hoist, cross travel. Long travel shall be in accordance with class M5 of IS:3177 (latest edition) and shall be suitable for indoor operation.	
7.02.07	The crane shall be complete with trolley and truck, wheels and axles, Drive mechanisms, Hoisting Drums, Brakes, Creep Speed Arrangement, Lifting tackles, Buffers Electric Motors, Controls, Switch Board and cabling, horns, warning lights, Limit switches etc. Any item not mentioned herein but required to make the system complete for the satisfactory performance of the crane shall also be included.	
7.02.08	The main hoist, trolley travel and crane travel for each movement shall be motor driven. Proper allowance shall be made for impact and wear in the design of the crane and the factor of safety shall be as per IS: 3177 based on the ultimate strength of the materials used at design duty. The design duty of crane structure, main hoist, cross travel and long travel shall conform to class M5 of the Indian Standard IS: 3177 (latest edition) or superior. The crane as a whole shall comply with the Indian Standard IS: 3177 / IS: 807 or approved equivalent international standard (latest edition).	
7.02.09	The hoist motors shall be provided with electro-magnetic brakes / Electro Hydraulic Thrust brakes. Electro - Hydraulic Thrust brakes shall be provided for cross travel & long travel. 2 X 100 % Brake shall be provided for each motion. Each brake for hoisting motion, cross travel, long travel etc., shall be designed as per following: Brakes to be as per IS 3177. The Capacity of hoisting motion brakes to be 150% of torque transmitted to the brake drum with full load and that of cross travel and long travel to be 125% of motor rated torque before deaerating.	
7.02.10	Safe means of access shall be provided and to every place of crane where examination/maintenance of any component is involved. A platform shall extend to full length of the crane bridge on both sides of the bridge girder. The platform shall be made of checkered Steel plate. A double tire hand-rail of height 1100 mm shall be provided along the outer edge of the platform and 75mm high toe-guards shall be provided all along the platforms and wherever else required from safety consideration. The width of platform shall not be less than 800mm in width and Guard rails shall be provided on the crab side of the bridge platform.	
7.02.11	LADDERS : Necessary access ladders shall be provided for access on to crane bridge platform from the gantry girder level, from crane bridge platform to trolley platform and from operating floor of pump to gantry girder level.	
7.02.12	The lifting tackle shall consist of a safety type lower pulley block, hook, necessary sheave and flexible steel wire ropes. The lower block sheaves and ropes shall be of adequate design and size to handle the specified loads. The hooks shall be of forged steel. The main hook shall be of Ramshorn type conforming to IS:5749 (latest edition) for 50 T and above capacity and shank type conforming to IS:15560 (latest edition) for capacity lower than 50 T. The factor of safety for the rope shall be as per IS:3177. The sheaves shall be of heavy duty with deep flanges made of cast steel and shall be properly grooved to fit the rope and adequately guarded.	
7.02.13	Each crane shall be controlled individually for all its motions from the control pendent panel.	
7.02.14	Each crane shall have a permanent inscription of English on each side, readily visible from the ground level, stating the safe working loads in tonnes for both the hooks, year of manufacture, crane serial number and manufacturer's name.	
7.02.15	The vertical deflection of crane girder shall not exceed 1/800 of the span. The girder shall be of box type and construction shall ensure non-accumulation of water/oil inside the box.	
7.03.00	<p>MAXIMUM SPAN/DEPTH RATIO FOR GIRDER:</p> <p>(a) Plate girders : 18</p> <p>(b) Lattice girders : 12</p>	

TALCHER THERMAL POWER PROJECT STAGE-III (2X660 MW) EPC PACKAGE	TECHNICAL SPECIFICATION SECTION-VI, PART-B BID DOC. NO.: CS-4540-001A-2	SUB SECTION-A-07 STEAM TURBINE AND AUXILIARIES SYSTEM	PAGE 19 OF 25
--	---	---	------------------

CLAUSE NO.	TECHNICAL REQUIREMENTS		
<p>7.04.00</p> <p>7.05.00</p> <p>8.00.00</p> <p>9.00.00</p>	<p>Material</p> <p>(i) Structural steel plates : Mild steel, grade 'B' of IS 2062 in 100% killed, normalised and ultrasonically tested quality or high strength steel of IS 8500 as appropriate</p> <p>(ii) Nuts & Bolts : As per IS:1363, IS:1364 and IS:1367. High Tension Friction grip bolts as per IS: 3757. High Tension Friction grip nuts as per IS: 6623.</p> <p>(iii) Electrodes : Radiography quality, covered electrodes with heavy covering as per IS : 814 and relevant requirements of ASME Sec. IX and IIC. Bare Electrodes as per IS:7280 and flux wire combination as per IS : 3613.</p> <p>(iv) Chequered plates : IS: 3502 (Minimum 6 mm thick O/P)</p> <p>(v) Hand rail pipes : 32 mm NB Medium class of IS : 1161 having top and bottom rail at height of 1050 mm and 600 mm and vertical post spacing not exceeding 1500 mm with provision of kick plate(100 mm high and 6 mm thick).</p> <p>(vi) Crane Rails : As per IS : 3443.</p> <p>7.05.00 Minimum thickness of Structure Members:</p> <p>(a) Load Carrying members: 8 mm</p> <p>(b) Tubes with both ends sealed : 4.9 mm (6 SWG)</p> <p>(c) Tubes with unsealed ends : 8 mm</p> <p>(d) Chequered plate : 6 mm O/P</p> <p>8.00.00 PRECOMMISSIONING ACTIVITIES</p> <p>The pre-commissioning activities including some of the important checks & tests for certain major equipment/ systems are mentioned under respective equipments, although it is the Contractor's responsibility to draw up a detailed sequential & systematic list of checks / tests and various activities / procedures connected with pre-commissioning of the complete facilities with all systems, sub-systems and equipment supplied and installed by him and get the same approved by the Employer.</p> <p>9.00.00 COMMISSIONING OF FACILITIES</p> <p>Upon completion of pre-commissioning activities/test the Contractor shall initiate commissioning of facilities. During commissioning the Contractor shall carryout system checking and reliability trials on various parts of the facilities.</p> <p>Contractor shall carry out these checks/tests at site to prove to the Employer that each equipment of the supply complies with requirements stipulated and is installed in accordance with requirements specified. Before the plant is put into initial operation the Contractor shall be required to conduct test to demonstrate to the Employer that each item of the plant is capable of correctly performing the functions for which it was specified and its performance, parameters etc. are as per the specified/approved values. These tests may be conducted concurrently with those required under commissioning sequence.</p>		
<p>TALCHER THERMAL POWER PROJECT STAGE-III (2X660 MW) EPC PACKAGE</p>	<p>TECHNICAL SPECIFICATION SECTION-VI, PART-B BID DOC. NO.: CS-4540-001A-2</p>	<p>SUB SECTION-A-07 STEAM TURBINE AND AUXILIARIES SYSTEM</p>	<p>PAGE 20 OF 25</p>

CLAUSE NO.	TECHNICAL REQUIREMENTS	एनटीपीसी NTPC	
10.00.00	<p>NOISE LEVEL</p> <p>In case the noise level pertaining to equipments covered under the scope exceeds the specified values, as given in relevant clause of General Technical requirement portion of Technical Specification, suitable acoustic enclosures, properly illuminated, having adequate inside space for movement (minimum 500 mm clear space on all sides from last equipment) alongwith all accessories in order to complete the system shall be provided to achieve the specified values. The acoustic enclosures & accessories shall be designed as per internationally accepted standards and shall be subject to Employer's approval.</p>		
11.00.00	<p>AVAILABILITY REQUIREMENTS OF TG AND AUXILIARIES</p> <p>The steam turbine generator unit and auxiliaries shall be designed for maximum reliability and availability, operability and maintainability particularly in respect of the following:</p>		
11.01.00	<p>All equipment and systems shall be of proven design, using proven materials with well established physical and chemical properties and as appropriate to the service as intended.</p>		
11.02.00	<p>The steam turbine generator unit and its auxiliaries shall be suitably designed and provided with required instrumentation for rapid starting, loading and unloading without causing undue vibration, distortion, differential expansion or producing excessive thermal stresses. Complete technical data including criteria for thermal stresses, cyclic loading, thermal fatigue, together with values of thermal stresses at critical locations shall be furnished to establish the suitability of design for cyclic and two shift operation.</p>		
11.03.00	<p>The steam turbine generator unit alongwith auxiliaries is normally expected to operate in sliding pressure mode from rated pressure down to 40% of rated pressure in conjunction with steam generator, HP-LP bypass system and plant instrumentation and control system.</p>		
11.04.00	<p>All stand-by auxiliaries shall be designed for auto start up, on failure of running auxiliaries with minimum time delay and without runback on unit load.</p>		
11.05.00	<p>Adequate maintenance facilities shall be provided as required for assembly, disassembly, alignment work particularly in respect of HP barrel, casing, inner and outer casings, diaphragm glands, steam valves, journal bearings, thrust bearings, turbine rotors, generator rotor, particularly end rings, shaft seals, generator bearings, hydrogen coolers, air cooled condenser system, vacuum pumps, condensate extraction pumps and boiler feed pump cartridges, BFP drive turbines, regenerative feed heaters, turbine oil coolers and pumps, etc. The offer shall give details like components requiring replacement or repairs during the life cycle of the plant, meantime between failures and list of tasks to be carried out during major overhauls.</p>		
12.00.00	<p>TYPE TESTS</p>		
12.01.01	<p>The contractor shall carry out the type tests as listed in the "TYPE TEST(S) TO BE CONDUCTED" on the equipment mentioned therein. The Bidder shall indicate the charges for each of these type tests separately in the relevant schedule of BPS and the same shall be considered for the evaluation of the Bids. The type test charges shall be paid only for the test(s) actually conducted successfully under this contract and upon certification by the Employer's Engineer.</p>		
12.01.02	<p>The type tests shall be carried out in presence of the Employer's representative, for which minimum 15 days notice shall be given by the Contractor. The Contractor shall obtain the Employer's approval for the type test procedure before conducting the type test. The type test procedure shall clearly specify the test set-up, instruments to be used, procedure,</p>		
TALCHER THERMAL POWER PROJECT STAGE-III (2X660 MW) EPC PACKAGE	TECHNICAL SPECIFICATION SECTION-VI, PART-B BID DOC. NO.: CS-4540-001A-2	SUB SECTION-A-07 STEAM TURBINE AND AUXILIARIES SYSTEM	PAGE 21 OF 25

CLAUSE NO.	TECHNICAL REQUIREMENTS			
12.01.03	<p>acceptance norms, recording of different parameters, interval of recording, precautions to be taken etc. for the type test(s) to be carried out.</p> <p>Irrespective of the requirement of conducting the type tests under this contract, the Contractor shall submit the reports of the type tests listed in the "TYPE TEST(S) TO BE CONDUCTED" and carried out within last five years from the date of bid opening. These reports should be for the tests conducted on the equipment same (model / type / size / rating) to those proposed to be supplied under this contract and the test(s) should have been either conducted at an independent laboratory or should have been witnessed by a client. The Employer reserves the right to waive conducting of any or all of the specified type tests under this contract, in which case the type test charges shall not be payable for the type tests waived by the Employer.</p>			
13.00.00	<p>All the Turbine & Auxiliaries equipments shall be designed following "Fail Safe" concept. In case of failure of Power supply like Electric power, Hydraulic pressure, Pneumatic pressure, Vacuum etc. the system should be designed in such a way that the equipment/Valves etc. shall always move/remains (as applicable) to safest position as per system requirement to ensure safety of Man and Machinery.</p>			
<p>TALCHER THERMAL POWER PROJECT STAGE-III (2X660 MW) EPC PACKAGE</p>	<p>TECHNICAL SPECIFICATION SECTION-VI, PART-B BID DOC. NO.: CS-4540-001A-2</p>	<p>SUB SECTION-A-07 STEAM TURBINE AND AUXILIARIES SYSTEM</p>	<p>PAGE 22 OF 25</p>	

CLAUSE NO.	TECHNICAL REQUIREMENTS		
	<p>c. Contractor shall provide electronic door detector (Infra red curtain type).</p> <p>d. Digital hall position indicator at all floors, tell lights at all floors shall also be provided by the Contractor.</p> <p>e. For facilitating the movement of visually & hearing impaired persons, hall lantern and car arrival chimes shall be provided</p> <p>f. All fixtures shall be in stainless steel face plates.</p> <p>g. Push buttons shall be fixed in the car for holding the doors open for any length of the time required.</p> <p>h. All other safety/protection/operation interlocks as required by IS:14665 (latest edition).</p>		
4.00.00	<p>POWER SUPPLY Each elevator shall be provided with a separate three phase, three wire 415V feeder of adequate rating</p>		
5.00.00	<p>Controls: The controls shall be Variable Voltage and Variable frequency type and shall provide smooth and constant acceleration and retardation under all conditions of operation . Suitable control panel shall be provided in the machine room.</p>		
6.00.00	<p>Cables and wiring: All the cables except trailing cables shall be as per IS:1554-1 or IS-7098-I. the PVC outer sheath of these cables shall be flame retardant, low smoke (FRLS) type with the following FRLS properties.</p> <p>a) Oxygen index of min. 29 (as per IS:10810 Part-58)</p> <p>b) Acid gas emission of max. 20% (as per IEC-754-I).</p> <p>c) Smoke density rating shall not be more than 60% (as per ASTM-D-2843).</p> <p>The circular trailing cables shall be either in accordance with IS 4289 Part-I (Elastomer insulated) or IS-4289 Part-II (PVC insulated). The flat type trailing cables if offered shall be in accordance with IEC-60227-6.</p> <p>All wiring / cabling between the equipment's in the lift machine room and that between the machine room and equipment's in the lift well and at the landings shall be wired in HDP conduits/ galvanized steel conduits to be supplied by the contractor. Alternatively armored cables may be used.</p>		
7.00.00	<p>Earthing: The elevator, EOT and crane structures and all Electrical equipment, including metal conduits shall be effectively earthed with the earth conductors provided in the machine room as per IS: 3043.</p>		
8.00.00	<p>EOT/ Hoist and Crane Motors</p>		
8.01.01	<p>Three phase Squirrel Cage Induction motors to be operated from VFD system shall be suitable for speed range and torque without exceeding temperature rise limits as specified elsewhere in this specification. These motors shall be provided with VPI insulation and insulated bearing on one side and shall be suitable for Inverter duty.</p> <p>Motors shall conform to latest revision of IS 325, IS 3177 and motor subsection of this specification.</p>		
8.02.00	<p>Controls</p> <p>i) Speed control of EOT crane shall be through Variable Voltage Variable Frequency System (VVVF) with minimum 6 (six) pulse design.</p>		
<p>TALCHER THERMAL POWER PROJECT STAGE-III (2X660 MW) EPC PACKAGE</p>	<p>TECHNICAL SPECIFICATION SECTION – VI, PART-B BID DOC NO : CS-4540-001A-2</p>	<p>SUB-SECTION-B-15 ELECTRICAL HOIST, CRANE AND ELEVATOR</p>	<p>Page 2 of 4</p>

CLAUSE NO.	TECHNICAL REQUIREMENTS		
8.03.00	<p>ii) Necessary input & output devices to be provided to reduce harmonics, as per IEE519, at supply side of the drive at the switchgear.</p> <p>iii) All necessary protections e.g. Input Phase Loss, Earth Fault, Over Voltage, Output Short Circuit, Load Loss, Input Transient Protection, Overload etc to be provided.</p> <p>iv) VVVF system shall be capable of generating suitable starting torque (upto 400% typical) with / without encoder, however starting current shall not exceed 150% at rated torque.</p> <p>v) VVVF system shall be capable of withstanding upto 50 deg C ambient temp without derating</p> <p>vi) Provision for controlling the motion from operator cabin (in case of Turbine hall EOT crane) as well as remote control shall be available.</p> <p>vii). Squirrel cage Induction motor with VPI insulation shall be provided With VVVF system.</p> <p>viii) Master controller - Desk type having following features.</p> <p>(i) Five speed control points in each direction of hoist motion.</p> <p>(ii) Four speed control points in each direction of bridge and trolley motion.</p> <p>(iii) Release of operator's hand from the controls shall stop motion and set brakes automatically.</p> <p>ix) Protective Panel Provided with isolating switch, power contactor control and indication to switch ON/OFF power to starter panels, control and lighting transformer.</p> <p>x) Starter Panel Separate VVVF system panels to be provided for CT, LT and hoist motion (main and auxiliary drives).</p> <p>a) Contactors : AC 4 duty for reversing application AC 3 duty for non reversing application</p> <p>b) Switches: AC 23 for motor application, AC 22 for other application.</p> <p>c) Fuses: HRC</p> <p>d) Overload relay : Temperature compensated, bimetallic with single phasing preventor.</p> <p>xi) Panel shall be fabricated out of 1.6 mm thick rolled sheet steel. IP 52 degree of protection. Paint shade shall be RAL 9002 for front & rear and RAL 5012 for side covers. Space heaters to be provided.</p> <p>Radio remote Control of EOT Crane:</p> <p>i) The equipment should have facility to control EOT crane by radio frequency based wireless remote unit. The equipment should be supplied with transmitter unit, receiver unit, encoder unit, decoder unit, interface panel, coupling system, battery unit and any other control gear if required.</p> <p>ii) The equipment should be based upon the microprocessor based digital technology with almost nil hard wiring.</p> <p>iii) The remote unit should communicate up to the distance of approximately 100 meters.</p> <p>iv) The system has to integrate with the control system of crane, which operates at 110 V AC, Single phase.</p>		
<p>TALCHER THERMAL POWER PROJECT STAGE-III (2X660 MW) EPC PACKAGE</p>	<p>TECHNICAL SPECIFICATION SECTION – VI, PART-B BID DOC NO : CS-4540-001A-2</p>	<p>SUB-SECTION-B-15 ELECTRICAL HOIST, CRANE AND ELEVATOR</p>	<p>Page 3 of 4</p>

CLAUSE NO.	TECHNICAL REQUIREMENTS		
7.06.0	<p>v) The remote unit should have transmitter which can be mounted on shoulder by suitable belt. Main controls can be of single joystick movement or double joystick movement type stepped control with spring return. The Micro control should be toggle switch type or push control type.</p> <p>vi) Frequency allotment for radio remote unit from Govt. of India, Deptt. of Telecommunication or any other agency shall be the responsibility of supplier.</p> <p>vii) The transmitter and receiver unit should have its own frequency and address code with each system having its own security code so that one particular set becomes unique and there is no interference from any other remote unit device. A microprocessor should check all security codes. The processor should have its own watchdog circuit. The receiver FM band should be sufficiently narrow to allow only passing of desired frequency and valid command. Any error should shut down the system immediately.</p> <p>viii) The remote unit should have safety key to prevent any unauthorized operation. All the crane operations should stop at once the communication break down occurs.</p> <p>ix) On local unit (receiver side), the system should be provided with one selector switch so that EOT crane can be operated either from Operator cabin or radio remote unit.</p> <p>x) In case tandem operation is envisaged, a suitable selector switch shall be provided in the cabin for selection of Tandem/normal operation.</p> <p>xi) The receiver unit along with I/O interface unit should be able to bear the vibrations and shocks encountered in normal usage of EOT crane.</p> <p>xii) The system should have very fast response time.</p> <p>Power Supply</p> <p>(a) Incoming numbers:</p> <p>(i) Turbine hall EOT crane: Contractor shall provide two (2) numbers 415 volts, 3 phase, 3 wire supply at operating floor near A-row column at centre of bay length with a changeover switch in enclosure.</p> <p>(ii) EOT crane for BFP: Contractor shall provide One (1) numbers 415 volts, 3 phase, 3 wire supply for each unit at BFP floor near B-row column.</p> <p>(b) Down shop Lead (DSL):</p> <p>(i) Shall conform to IS : 282 and shall be sized to Cater to all cranes working simultaneously with 40% cyclic duration factor for load.</p> <p>-Limit voltage drop at motor terminals within 2% at extreme positions.</p> <p>(ii) DSL shall be sized with a margin of 10% over load requirement.</p> <p>(iii) Protective cover over DSL to be provided.</p> <p>(iv) Two (2) numbers isolating switches in enclosure shall be provided at extreme ends of operating floor for disconnecting supply to DSL while maintaining the crane.</p> <p>(v) DSL shall be located on 'A' -row side for Turbine hall EOT crane.</p> <p>(c) Transformers Dry type, with insulation class B or better. Following transformers shall be provided.</p> <p>(i) Control Transformers : 2x100%, 415V / 110V</p> <p>(ii) Lighting Transformers : One 415V/240V</p> <p>(iii) Hand lamp : One 415V/24V</p>		
TALCHER THERMAL POWER PROJECT STAGE-III (2X660 MW) EPC PACKAGE	TECHNICAL SPECIFICATION SECTION – VI, PART-B BID DOC NO : CS-4540-001A-2	SUB-SECTION-B-15 ELECTRICAL HOIST, CRANE AND ELEVATOR	Page 4 of 4

CLAUSE NO.	TECHNICAL REQUIREMENTS																											
	<p style="text-align: center;">MOTORS</p> <p>1.00.00 GENERAL REQUIREMENTS</p> <p>1.01.00 This chapter has to be read in conjunction with sub-section B-0 "General electrical specification" of Technical specification Section- VI, Part-B and Sub-Section-IIB Electrical system/Equipment of Technical Specifications Section-VI, Part-A"</p> <p>Degree of Protection</p> <p>Degree of protection for various enclosures as per IEC60034-05 shall be as follows :-</p> <table border="0"> <tr> <td>i) Indoor motors</td> <td>-</td> <td>IP 55</td> </tr> <tr> <td>ii) Outdoor motors</td> <td>-</td> <td>IP 55 (Additional Canopy to be provided)</td> </tr> <tr> <td>iii) Cable box-indoor area</td> <td>-</td> <td>IP 55</td> </tr> <tr> <td>iv) Cable box-Outdoor area</td> <td>-</td> <td>IP 55</td> </tr> </table> <p>2.00.00 CODES AND STANDARDS</p> <table border="0"> <tr> <td>1) Three phase induction motors</td> <td>:</td> <td>IS15999/IEC:60034</td> </tr> <tr> <td>2) Single phase AC motors</td> <td>:</td> <td>IS 996/ IEC:60034</td> </tr> <tr> <td>3) Crane duty motors</td> <td>:</td> <td>IS:3177, IEC:60034</td> </tr> <tr> <td>4) DC motors/generators</td> <td>:</td> <td>IS:4722, IEC:60034</td> </tr> <tr> <td>5) Energy Efficient motors</td> <td>:</td> <td>IS 12615, IEC:60034-30</td> </tr> </table> <p>3.00.00 TYPE</p> <p>3.01.00 AC Motors:</p> <p>a) Squirrel cage induction motor suitable for direct-on-line starting.</p> <p>b) Continuous duty LT motors upto 200 KW Output rating (at 50 deg.C ambient temperature), shall be Premium Efficiency class-IE3, conforming to IS 12615, or IEC:60034-30. HT motors shall have minimum design efficiency of 95 %. However, tolerance on this efficiency value shall be applicable as per IEC 60034</p> <p>c) Motor operating through variable frequency drives shall be suitable for inverter duty with VPI insulation. Also these motors shall comply the requirements stipulated in IEC: 60034-18-41 and IEC: 60034-18-42 as applicable.</p> <p>3.02.00 DC Motors: Shunt wound.</p> <p>4.00.00 RATING</p> <p>(a) Continuously rated (S1). However, crane motors shall be rated for S4 duty, 40% cyclic duration factor.</p> <p>(b) Whenever the basis for motor or driven equipment ratings are not specified in the corresponding mechanical specification sub-sections, maximum continuous motor ratings shall be at least 10% above the maximum load demand of the driven equipment under entire operating range including voltage and frequency variations.</p> <p>5.00.00 TEMPERATURE RISE</p> <p>Air cooled motors</p> <p>70 deg. C by resistance method for both thermal class 130(B) & 155(F) insulation.</p> <p>Water cooled</p> <p>80 deg. C over inlet cooling water temperature mentioned elsewhere, by resistance method for both thermal class 130(B) & 155(F) insulation.</p>	i) Indoor motors	-	IP 55	ii) Outdoor motors	-	IP 55 (Additional Canopy to be provided)	iii) Cable box-indoor area	-	IP 55	iv) Cable box-Outdoor area	-	IP 55	1) Three phase induction motors	:	IS15999/IEC:60034	2) Single phase AC motors	:	IS 996/ IEC:60034	3) Crane duty motors	:	IS:3177, IEC:60034	4) DC motors/generators	:	IS:4722, IEC:60034	5) Energy Efficient motors	:	IS 12615, IEC:60034-30
i) Indoor motors	-	IP 55																										
ii) Outdoor motors	-	IP 55 (Additional Canopy to be provided)																										
iii) Cable box-indoor area	-	IP 55																										
iv) Cable box-Outdoor area	-	IP 55																										
1) Three phase induction motors	:	IS15999/IEC:60034																										
2) Single phase AC motors	:	IS 996/ IEC:60034																										
3) Crane duty motors	:	IS:3177, IEC:60034																										
4) DC motors/generators	:	IS:4722, IEC:60034																										
5) Energy Efficient motors	:	IS 12615, IEC:60034-30																										
<p style="text-align: center;">TALCHER THERMAL POWER PROJECT STAGE-III (2X660 MW) EPC PACKAGE</p>	<p style="text-align: center;">TECHNICAL SPECIFICATION SECTION – VI, PART-B BID DOC NO : CS-4540-001A-2 Page 42 of 368</p>	<p style="text-align: center;">SUB SECTION-II-B-02 MOTORS</p>	<p style="text-align: center;">PAGE 1 OF 4</p>																									

CLAUSE NO.	TECHNICAL REQUIREMENTS		
<p>6.00.00</p> <p>6.01.00</p> <p>6.01.01</p> <p>6.01.02</p> <p>6.01.03</p> <p>6.01.04</p> <p>6.02.00</p> <p>6.02.01</p> <p>6.02.02</p> <p>6.03.00</p>	<p>OPERATIONAL REQUIREMENTS</p> <p>Starting Time</p> <p>For motors with starting time upto 20 secs. at minimum permissible voltage during starting, the locked rotor withstand time under hot condition at highest voltage limit shall be at least 2.5 secs. more than starting time.</p> <p>For motors with starting time more than 20 secs. and upto 45 secs. at minimum permissible voltage during starting, the locked rotor withstand time under hot condition at highest voltage limit shall be at least 5 secs. more than starting time.</p> <p>For motors with starting time more than 45 secs. at minimum permissible voltage during starting, the locked rotor withstand time under hot condition at highest voltage limit shall be more than starting time by at least 10% of the starting time.</p> <p>Speed switches mounted on the motor shaft shall be provided in cases where above requirements are not met.</p> <p>Torque Requirements</p> <p>Accelerating torque at any speed with the lowest permissible starting voltage shall be at least 10% motor rated torque.</p> <p>Pull out torque at rated voltage shall not be less than 205% of rated torque. It shall be 275% for crane duty motors.</p> <p>NOT USED.</p>		
<p>7.00.00</p> <p>7.01.00</p> <p>7.02.00</p> <p>7.03.00</p>	<p>DESIGN AND CONSTRUCTIONAL FEATURES</p> <p>Suitable single phase space heaters shall be provided on motors rated 30KW and above to maintain windings in dry condition when motor is standstill. Separate terminal box for space heaters & RTDs shall be provided. However for flame proof motors, space heater terminals inside the main terminal box may be acceptable.</p> <p>All motors shall be either Totally enclosed fan cooled (TEFC) or totally enclosed tube ventilated (TETV) or Closed air circuit air cooled (CACWA) type. However, motors rated 3000KW or above can be Closed air circuit water cooled (CACW). The method of movement of primary and secondary coolant shall be self-circulated by fan or pump directly mounted on the rotor of the main motor as per IEC 60034-6. However VFD driven motors can be offered with forced cooling type with machine mounted fan or pump driven by separate electric motor. Motors and EPB located in hazardous areas shall have flame proof enclosures conforming to IS:2148 as detailed below</p> <p>(a) Fuel oil area : Group – IIB</p> <p>(b) Hydrogen generation : Group - IIC or (Group-I, Div-II as per plant area NEC) or (Class-1, Group-B, Div-II as per NEMA /IEC60034)</p> <p>Winding and Insulation</p> <p>Type : Electrolytic grade Copper conductor, Non-hygroscopic, oil resistant, flame resistant Insulation.</p> <p>Starting duty : Two hot starts in succession, with motor initially at normal running temperature.</p> <p>However, conveyor motors shall be suitable for 3 consecutive hot starts</p> <p>11kV, 6.6 KV & 3.3 kV AC motors : Thermal class 155 (F) insulation. The winding insulation process shall be total Vacuum Pressure Impregnated i.e resin poor method. The lightning Impulse & interturn insulation surge withstand level shall be as per IEC-60034 part-15.</p>		
<p>TALCHER THERMAL POWER PROJECT STAGE-III (2X660 MW) EPC PACKAGE</p>	<p>TECHNICAL SPECIFICATION SECTION – VI, PART-B BID DOC NO : CS-4540-001A-2 Page 43 of 368</p>	<p>SUB SECTION-II-B-02 MOTORS</p>	<p>PAGE 2 OF 4</p>

CLAUSE NO.	TECHNICAL REQUIREMENTS		
	<p>240VAC, : Thermal Class (F) or better 415V AC & 220V DC motors</p>		
7.04.00	Motors rated above 1000KW shall have insulated bearings/housing to prevent flow of shaft currents.		
7.05.00	Motors with heat exchangers shall have dial type thermometer with adjustable alarm contacts to indicate inlet and outlet primary air temperature.		
7.06.00	Noise level for all the motors shall be limited to 85 dB(A) except for BFP motor for which the maximum limit shall be 90dB(A). Vibration shall be limited within the limits prescribed in IS:12075 / IEC 60034-14 . Motors shall withstand vibrations produced by driven equipment. HT motor bearing housings shall have flat surfaces, in both X and Y directions, suitable for mounting vibration pads.		
7.07.00	In HT motors, at least four numbers simplex / two numbers duplex platinum resistance type temperature detectors shall be provided in each phase stator winding. Each bearing of HT motor shall be provided with three numbers duplex RTDs connected to three numbers dual input transmitters with display. However for air compressor, being high speed drive, each motor bearing shall be provided with minimum two numbers of duplex RTDs connected to two numbers dual input transmitters with display unit.7.08.00 Motor body shall have two earthing points on diagonally opposite sides.		
7.09.00	11 KV motors shall be offered with Separable Insulated Connector (SIC) as per IEEE 386. The offered SIC terminations shall be provided with protective cover and trifurcating sleeves. SIC termination kit shall be suitable for fault level of 25 KA for 0.17 seconds.		
7.10.00	3.3/6.6 KV motors shall be offered with dust tight phase segregated double walled (metallic as well as insulated barrier) Terminal box. Contractor shall provide termination kit for the offered Terminal box. The offered Terminal Box shall be suitable for fault level of 250 MVA for 0.12 sec. Removable gland plates of thickness 3 mm (hot/cold rolled sheet steel) or 4 mm (non magnetic material for single core cables) shall be provided.		
7.11.00	The spacing between gland plate & centre of bottom terminal stud shall be as per Table-I.		
7.12.00	All motors shall be so designed that maximum inrush currents and locked rotor and pullout torque developed by them at extreme voltage and frequency variations do not endanger the motor and driven equipment.		
7.13.00	The motors shall be suitable for bus transfer schemes provided on the 11kV, 6.6 KV, 3.3 KV /415V systems without any injurious effect on its life.		
7.14.00	For motors rated 2000 KW & above, neutral current transformers of PS class shall be provided on each phase in a separate neutral terminal box.		
7.15.00	NOT USED		
8.00.00	NOT USED		
10.00.00	TYPE TEST		
10.01.00	<p>HT MOTORS</p> <p>LIST OF TYPE TESTS TO BE CONDUCTED</p> <p>The following type tests shall be conducted on each type and rating of HT motor</p> <p>(a) No load saturation and loss curves upto approximately 115% of rated voltage</p> <p>(b) Measurement of noise at no load.</p> <p>(c) Momentary excess torque test (subject to test bed constraint).</p> <p>(d) Full load test(subject to test bed constraint)</p>		
<p>TALCHER THERMAL POWER PROJECT STAGE-III (2X660 MW) EPC PACKAGE</p>	<p>TECHNICAL SPECIFICATION SECTION – VI, PART-B BID DOC NO : CS-4540-001A-2 Page 44 of 368</p>	<p>SUB SECTION-II-B-02 MOTORS</p>	<p>PAGE 3 OF 4</p>

CLAUSE NO.	TECHNICAL REQUIREMENTS		
	<p>(e) Temperature rise test at rated conditions. During heat run test, bearing temp., winding temp., coolant flow and its temp. shall also be measured. In case the temperature rise test is carried at load other than rated load, specific approval for the test method and procedure is required to be obtained. Wherever ETD's are provided, the temperature shall be measured by ETD's also for the record purpose.</p> <p>LIST OF TESTS FOR WHICH REPORTS HAVE TO BE SUBMITTED</p> <p>The following type test reports shall be submitted for each type and rating of HT motor</p> <p>(a) Degree of protection test for the enclosure followed by IR, HV and no load run test.</p> <p>(b) Terminal box-fault level withstand test for each type of terminal box of HT motors only.</p> <p>(c) Lightning Impulse withstand test on the sample coil shall be as per clause no. 4.3 IEC-60034, part-15</p> <p>(d) Surge-withstand test on inter-turn insulation shall be as per clause no. 4.2 of IEC 60034, part-15</p>		
10.02.00	<p>LT Motors</p> <p>LIST OF TESTS FOR WHICH REPORTS HAVE TO BE SUBMITTED</p> <p>The following type test reports shall be submitted for each type and rating of LT motor of above 100 KW only</p> <ol style="list-style-type: none"> 1. Measurement of resistance of windings of stator and wound rotor. 2. No load test at rated voltage to determine input current power and speed 3. Open circuit voltage ratio of wound rotor motors (in case of Slip ring motors) 4. Full load test to determine efficiency power factor and slip 5. Temperature rise test 6. Momentary excess torque test. 7. High voltage test 8. Test for vibration severity of motor. 9. Test for noise levels of motor(Shall be limited as per clause no 7.06.00 of this section) 10. Test for degree of protection and 11. Overspeed test. 12. Type test reports for motors located in fuel oil area having flame proof enclosures as per IS 2148 / IEC 60079-1 		
10.03.00	<p>All acceptance and routine tests as per the specification and relevant standards shall be carried out. Charges for these shall be deemed to be included in the equipment price.</p>		
10.04.00	<p>The type test reports once approved for any projects shall be treated as reference. For subsequent projects of NTPC, an endorsement sheet will be furnished by the manufacturer confirming similarity and "No design Change". Minor changes if any shall be highlighted on the endorsement sheet.</p>		
<p>TALCHER THERMAL POWER PROJECT STAGE-III (2X660 MW) EPC PACKAGE</p>	<p>TECHNICAL SPECIFICATION SECTION – VI, PART-B BID DOC NO : CS-4540-001A-2 Page 45 of 368</p>	<p>SUB SECTION-II-B-02 MOTORS</p>	<p>PAGE 4 OF 4</p>





SUB-SECTION-B – 03

VFD

TALCHER THERMAL POWER PROJECT STAGE-III (2X660 MW)
EPC PACKAGE
BID DOC NO.: CS-4540-001A-2

TECHNICAL SPECIFICATION
SECTION - VI
PART-B

CLAUSE NO.	TECHNICAL REQUIREMENTS		
1.00.0	<u>VFD</u>		
	GENERAL		
	This chapter has to be read in conjunction with sub-section B-0 "General electrical specification" of Technical specification Section- VI, Part-B and Sub-Section-IIB Electrical system/Equipment of Technical Specifications Section-VI, Part-A.		
2.00.00	CODES AND STANDARDS		
	HT breaker	IEC:60056	
	DC reactor	IEC 60289	
	Transformers	IS:2026, IEC:60076, IEC 61378	
	Bushing	IS: 2099, IEC 60137	
	Adjustable Speed Electrical Power Drive Systems	IEC 61800	
	Semiconductor converters–General requirements	IEC 60146	
	IEEE Recommended practices and requirements for harmonic control in electrical power systems - IEEE 519		
	Degrees of protection provided by enclosures (IP Code)	IEC 60529	
	Electrostatic immunity test	IEC1000-4-2	
	Fast transient immunity test	IEC1000-4-4	
	Surge immunity test	IEC1000-4-5	
	High-voltage switchgear and controlgear; Pt.102: Alternating current disconnectors and earthing switches IEC 62271-102		
TALCHER THERMAL POWER PROJECT STAGE-III (2X660 MW) EPC PACKAGE	TECHNICAL SPECIFICATION SECTION – VI, PART-B BID DOC NO : CS-4540-001A-2	SUB-SECTION : B-03 VFD	PAGE 1 OF 11

CLAUSE NO.	TECHNICAL REQUIREMENTS 		
	<p>High-voltage switchgear and controlgear; Pt.200: AC metal-enclosed switchgear and controlgear for rated voltages above 1 kV and up to and including 52 KV IS/IEC: 62271-200</p> <p>AC electricity meters IS: 722</p> <p>Metal oxide surge arrester without gap for AC system IEC: 60099-4</p> <p>Terminal blocks for copper conductors IEC: 60947-7-1</p> <p>Dry transformer IS: 11171</p> <p>Motor IS:15999, IEC-60034, IEC60034 / NEMA 30 & 31</p> <p>Contactor/Switches/Fuses etc. IEC:60947, IS: 13947</p> <p>Harmonics & EM compatibility IEEE:519/IEC: 61000</p> <p>VFD IEC: 60034/ IEC: 61800</p>		
3.00.00	OPERATING CONDITIONS		
3.01.00	For the purpose of design of equipment/systems, an ambient temperature of 50 deg. Centigrade and also relative humidity of 95% at 40 deg. Celsius shall be considered.		
3.02.00	All equipment shall be suitable for rated frequency of 50 Hz with a variation of +3% & -5%, and 10% combined variation of voltage and frequency unless specifically brought out in the specification.		
3.03.00	<p>The voltage level for the VFD output to be fed to motor shall be as follows:-</p> <ol style="list-style-type: none"> 1. Upto 400 kW : 415V/690V, Low Voltage, Three Phase AC 2. Above 400kW and upto 700 KW : 690V, Low Voltage, Three Phase AC 3. Above 700KW : Medium Voltage <p>From here onwards in the specifications all the VFD Systems consisting of either 415 V or 690 V may be termed as LV VFD while the higher rated VFD System shall be termed as MV VFD. If nothing is mentioned than the Clause is applicable for both the LV and the MV VFD until deliberated otherwise.</p>		
TALCHER THERMAL POWER PROJECT STAGE-III (2X660 MW) EPC PACKAGE	TECHNICAL SPECIFICATION SECTION – VI, PART-B BID DOC NO : CS-4540-001A-2	SUB-SECTION : B-03 VFD	PAGE 2 OF 11

CLAUSE NO.	TECHNICAL REQUIREMENTS			
4.00.00	SYSTEM DESCRIPTION <p>Type of drive 3-Phase Diode / Thyristor / Multi Stage IGBT / IGCT / SGCT/ IEGT</p> <p>Type of Cooling of VFD Naturally air cooled/forced air cooled/Liquid cooled</p> <p>Converter Type Full wave diode rectifier/active front end type</p> <p>Inverter Type Thyristor/IGBT/IGCT/SGCT/IEGT</p>			
5.00.00	GENERAL REQUIREMENTS			
5.01.00	Medium Voltage VFD: The Variable frequency drive (VFD) system shall be of a modern proven design for similar applications in power plants/industry. The system shall be either Current Source Inverter (CSI) or Voltage Source Inverter (VSI) type with minimum eighteen (18) pulse design.			
5.02.00	415 V/690 V LV VFD: The Variable frequency drive (VFD) system shall be of a modern proven design for similar applications in power plants/industry. The system shall be either Current Source Inverter (CSI) or Voltage Source Inverter (VSI) type with minimum Twelve (12) pulse design / 6 pulse with active front end harmonic filter. For drives less than 100 KW Six (6) pulse can be offered meeting all other requirements.			
5.04.00	The offered equipment shall be with state of art technology and proven field track record. No prototype equipment shall be offered.			
5.05.00	The VFD manufacturer shall ensure the proper coordination of their VFD with the Driven Motor and the supply system. The VFD operation shall have no inherent detrimental impact on the Motors/ cables & supply system.			
6.00.00	TECHNICAL AND OPERATIONAL REQUIREMENTS			
6.01.00	The system shall be designed to deliver the motor input current and torque for the complete speed torque characteristics of the driven equipment, with worst input supply voltage and frequency variation. The system shall be suitable for the load characteristics and the operational duty of the driven equipment.			
6.02.00	The overload capacity of the controller shall be 150% of the rated current of the motor for one minute for constant torque applications and 110% of rated current for one minute for variable torque applications at rated voltage. If the motor load exceeds the limit, the drive shall automatically reduce the frequency and voltage to the motor to guard against overload.			
6.03.00	The drive system shall be designed to operate in one or more of the following operating modes as to suit characteristics of the driven equipment or specified by the load: <ul style="list-style-type: none"> a. Variable torque changing as a function of speed. b. Constant torque over a specific speed range. c. Constant power over a specific speed range. 			
TALCHER THERMAL POWER PROJECT STAGE-III (2X660 MW) EPC PACKAGE	TECHNICAL SPECIFICATION SECTION – VI, PART-B BID DOC NO : CS-4540-001A-2	SUB-SECTION : B-03 VFD	PAGE 3 OF 11	

CLAUSE NO.	TECHNICAL REQUIREMENTS		
	d. Any other as specified in data-sheet		
6.04.00	VFDs shall comply with the latest edition of IEEE 519 & IEC 61000 for both individual as well as total harmonic voltage and current distortion limits. The Voltage and Current limits shall be applicable at the Point of Common Coupling (PCC), which shall be the MCC/ Switchgear/ from which the VFD system is fed.		
6.05.00	The above compliance shall be verified by the field measurements of harmonics at the PCC with and without VFDs operation.		
6.06.00	VFD shall be capable of withstanding the thermal and dynamic stresses and the transient mechanical torque, resulting from short circuit. Any damage resulting from such a short circuit or internal fault shall be limited to the component concerned.		
6.07.00	The system shall be suitable to maintain speed variation within range 10-110% or as per the requirement of driven equipment with speed set accuracy of +1% of rated maximum speed and steady state regulation of +0.5% of rated speed as per system requirement.		
6.08.00	The VFD System shall maintain a power factor of 0.95 (minimum) (for LV VFD system) and 0.9 (minimum) (for MV VFD system) in the entire operating range.		
6.09.00	Maximum allowable audible noise from the VFD system will be 85 dB (A) at a distance of one meter under rated loaded with all cooling fan operating conditions.		
6.10.00	All the circuit components shall be suitably protected against over voltages, surges, lightning etc.		
6.11.00	The panels shall be designed to provide easy access to hardware, to facilitate replacement of cards in case of any failure.		
6.12.00	All the VFDs for particular application shall be of same design so as to ensure 100 % interchangeability of components.		
6.13.00	For each programmed warning and fault protection function, the VFD shall display a message in complete English words or Standard English abbreviations. At least 30 time tagged fault messages shall be stored in the drive's fault history.		
6.14.00	The VFD cubicles shall be placed in air conditioned environment. However if VFDs of less than 100 kW are designed to operate in non-air condition environment the same shall also be acceptable.		
6.15.00	The 3-Phase Thyristor/IGCT/SGCT/ multistage IGBT/IEGT based VFD system shall have minimum number of components to ensure very high reliability. The input side converter shall have 3-Phase Diode/Thyristor bridge configuration modular type and inverter shall be of 3-Phase Thyristor/IGCT/SGCT/multi stage IGBT/IEGT type, using Pulse Width Modulation or better technique for generating near sine wave output to motor.		
6.16.00	Fiber optic cable connection shall be provided preferably to ensure high network reliability.		
7.00.00	VFD COMPATIBILITY WITH THE MOTOR		
7.01.00	MV VFD output current waveform, as measured at the motor, shall be inherently sinusoidal at nominal loads, with a total harmonic current and voltage distortion within acceptable/standard limits. VFD with transformers on output side are not acceptable.		
TALCHER THERMAL POWER PROJECT STAGE-III (2X660 MW) EPC PACKAGE	TECHNICAL SPECIFICATION SECTION – VI, PART-B BID DOC NO : CS-4540-001A-2	SUB-SECTION : B-03 VFD	PAGE 4 OF 11

CLAUSE NO.	TECHNICAL REQUIREMENTS		
7.02.00	The system design shall not have any inherent output harmonic resonance in the operating speed range.		
7.03.00	VFD shall provide stable operation of motor from high-voltage dv/dt stress, regardless of cable length to motor. The vendor shall clearly state the limitations in the motor cable distance in his proposal. However, due to system requirements & constraints if the cable length becomes critical, filters/ chokes etc. shall be provided by the VFD manufacturers as an integral part of the VFD to mitigate the reflected wave effect of harmonics.		
8.00.00	BYPASS ARRANGEMENT (OPTIONAL, IF SPECIFIED)		
8.01.00	The VFD System shall have an optional feature to run the motor under bypass arrangement for operation of Motor with VFD bypassed. During starting (under rated conditions) the motor will be switched on in VFD Mode to limit the starting current and after gaining speed, the load would be switched over to bypass mode.		
8.02.00	Comprehensive motor protection scheme for protection and control for operation VFD during bypass mode shall be finalized during detailed engineering.		
9.00.00	STANDBY VFD ARRANGEMENT (OPTIONAL, IF SPECIFIED)		
9.01.00	A Common standby arrangement with auto/manual switchover shall be provided in case of failure of any VFD in a group of drives. Complete protection, interlocks & control required shall be provided in the changeover module.		
10.00.00	EFFICIENCY		
10.01.00	Efficiency (Drive only) shall be minimum 98% for both MV VFD and LV VFD. Overall efficiency (Includes the transformer if applicable) shall be minimum 96.5% for LV VFD and minimum 95 % for MV VFD at rated load and speed. Overall Efficiency evaluation shall include input transformer, harmonic filters and power factor correction (if applicable), VFD converters, cooling fans and output filter, as applicable in the system. Auxiliary controls, such as internal VFD control boards, cooling fans/pumps.		
10.02.00	In absence of valid test report, a factory test shall be performed at the VFD manufacturer's facility verifying the efficiencies. Manufactures who are supplying Drive and transformer from different locations, efficiency test will be conducted separately for Drive and transformer.		
11.00.00	COOLING SYSTEM		
11.01.00	VFD manufacturer to primarily offer Air cooled Design. However in case of large ratings, liquid cooled drives may be accepted subject to employer's approval. In case of liquid cooled system, there shall be no necessity of continuous water supply system (Closed Loop System).		
11.2.00	In case of Air cooled design, the VFD Cooling system shall be such that it puts minimum heat load inside the room and preferably throw the hot air outside the room with ventilation ducts. The Cooling system shall be designed in such a way that the Air Conditioning & Ventilation Air requirements are kept to minimum. The VFD Manufacturer shall furnish the data regarding heat load, air flow requirements during the detailed engineering.		
11.03.00	Air cooled VFDs shall be provided with cooling fans mounted integral to the VFD/ enclosure. The VFD shall include air-flow pressure switches and temperature detectors to monitor proper operation of the air cooling system. If the fan fails, the system must generate the alarm/trip for the fan failure.		
TALCHER THERMAL POWER PROJECT STAGE-III (2X660 MW) EPC PACKAGE	TECHNICAL SPECIFICATION SECTION – VI, PART-B BID DOC NO : CS-4540-001A-2	SUB-SECTION : B-03 VFD	PAGE 5 OF 11

CLAUSE NO.	TECHNICAL REQUIREMENTS		
12.00.00	TRANSFORMER:		
12.01.00	Type: Outdoor Mineral oil filled ONAN type or Indoor air-cooled Dry type, Three phase unit, rectifier/converter duty type transformer.		
12.02.00	All other components, technical parameters shall be as per applicable IEC/IS.		
12.03.00	Enclosure for Dry Type Transformer (as applicable)		
	Enclosure shall be of a tested quality sheet steel of minimum thickness 2 mm & shall also accommodate cable terminations. The housing door shall be interlocked such that it should be possible to open the door only when transformer is off. The enclosure shall be provided with lifting lugs and other hardware for floor mounting.		
12.04.00	Core	Shall be High grade non-ageing cold rolled grain oriented silicon steel Laminations.	
12.05.00	Winding conductor	Shall be electrolytic grade copper. Windings shall be of class F insulation or better.	
12.06.00	Winding temperature Indicator (WTI)	Shall be Platinum resistance type temperature detector in each limb.	
12.07.00	Thermistors	Shall be embedded in each limb with alarm and trip contacts for remote annunciation.	
12.08.00	Temperature rise:	For dry type transformer the winding temperature rise shall be 95 Deg. C for Class-H insulation or 70 Deg.C for Class – F Insulation.	
13.00.00	POWER CONVERTER:		
13.01.00	The static power converter shall consist of a line side converter for operation as a rectifier and a load side power converter for operation as a fully controller inverter. Power converter shall be fast switching, most efficient and low loss type.		
13.02.00	The converter shall be coordinated with the transformers. The converter shall be able to withstand a three phase short circuit current until interrupted by normal breaker operation.		
13.03.00	Adequate short circuit and over voltage protection shall be provided for the converter and inverter system.		
13.04.00	All power converter devices shall include protective devices, snubber networks and dv/dt networks as required.		
13.05.00	The current rating of the converter's semi-conductor components shall not be less than 120% of the nominal current flowing through the elements at full load of the VFD through the whole speed range. If the parallel connection of semiconductor is applied, the above current rating shall not be less than 140% of the above values.		
13.06.00	All power diodes shall be of silicon type with minimum VBO rating at 2.5 times the rated operating voltage.		
13.07.00	The power converter circuit shall be designed so that motor can be powered at its full nameplate rating continuously without exceeding its rated temperature rise nor reducing its service factor due to harmonic currents generated by the inverter operation. The conversion		
TALCHER THERMAL POWER PROJECT STAGE-III (2X660 MW) EPC PACKAGE	TECHNICAL SPECIFICATION SECTION – VI, PART-B BID DOC NO : CS-4540-001A-2	SUB-SECTION : B-03 VFD	PAGE 6 OF 11

CLAUSE NO.	TECHNICAL REQUIREMENTS		
	<p>devices and associated heat sinks shall be assembled such that individual devices can be replaced without requiring the use of any special precautions / tools.</p>		
13.08.00	<p>The cooling system of the electronic components, if provided, shall be monitored and necessary alarms shall be provided to prevent any consequential damage to the power control devices.</p>		
14.00.00	<p>OUTPUT FILTER (AS APPLICABLE):</p>		
14.01.00	<p>Output/ dv/dt filter shall be provided, if required. It shall be an integral part of the VFD system and included within the VFD enclosure. It shall inherently protect motor from high voltage dv/dt stress.</p>		
15.00.00	<p>DC LINK CAPACITOR (AS APPLICABLE):</p>		
15.01.00	<p>Capacitor shall be of self-healing film or electrolytic type having high life time. The capacitor shall be an integral part of VFD system. DC link Capacitors shall have discharge resistors which shall be capable of reducing the residual charges to zero just after the capacitor is disconnected from the supply source. The capacitor shall be suitable for high ripple currents.</p>		
16.00.00	<p>AC/DC Reactor (As applicable)</p> <ol style="list-style-type: none"> 1) Type: Dry type, air cored, self cooled, indoor type. Suitable for withstanding earth fault continuously. 2) Insulation: Thermal Class 155(F), temperature rise is limited to thermal class 130 (B). 3) Noise level shall not exceed value specified in NEMA TR-1. 		
17.00.00	<p>VFD PANEL REQUIREMENTS</p>		
17.01.00	<p>Enclosure frames and load bearing members shall be as per the Chapter B-05 and B06</p>		
17.02.00	<p>The cable entry shall be from the bottom of the panel and a removable bolted un-drilled gland plate.</p>		
17.03.00	<p>All Panels shall be of dust-proof and vermin-proof construction and shall be provided with a degree of protection of IP: 3X or better for MV VFD and IP: 4X or better for LV VFD as per IS/IEC 60947</p>		
17.04.00	<p>Enclosures must be designed to avoid harmonic and inductive heating effects and to shield any outside equipment from interference, enclosing and shielding the complete to eliminate any radio frequency interference. The construction of the panel shall provide effective protection against electromagnetic emissions.</p>		
17.05.00	<p>Each panel shall be provided with illuminating lamp, space heater with switch fuse and variable setting thermostat.</p>		
17.06.00	<p>Proper ventilation using air filters and fans/pumps shall be provided in the panels to ensure that maximum temperature inside the cubicle is within permissible limits for reliable and continuous operation of the system.</p>		
18.00.00	<p>NOT USED</p>		
19.00.00	<p>HT SWITCHGEAR</p>		
19.01.00	<p>The technical requirements of HT switchgear shall be as per chapter of HT switchgear in Part-B of Technical specifications.</p>		
<p>TALCHER THERMAL POWER PROJECT STAGE-III (2X660 MW) EPC PACKAGE</p>	<p>TECHNICAL SPECIFICATION SECTION – VI, PART-B BID DOC NO : CS-4540-001A-2</p>	<p>SUB-SECTION : B-03 VFD</p>	<p>PAGE 7 OF 11</p>

CLAUSE NO.	TECHNICAL REQUIREMENTS		
20.00.00	MOTORS		
20.01.00	VFD shall be used to drive three (3) phase squirrel cage inverter duty Induction motor with VPI insulation (Resin poor) suitable for VFD application. These motors shall be provided with insulated bearing on at least one side for motor frame size above 250 frame. However, contractor's proven practice with respect to use of insulated bearing in VFD driven motor may be accepted subject to Employer's approval.		
20.02.00	Motors shall also meet the requirements mentioned in subsection for motors, relevant portions of the specifications for driven equipment and relevant IS/IEC.		
20.03.00	Motor shall be suitable for operation with a solid state power supply consisting of an adjustable frequency inverter for speed control & shall be suitable for the current waveforms produced by the power supply including the harmonics generated by the drive.		
20.04.00	Motor insulation shall be designed to accept the applied voltage waveform, within the Vpeak and dv/dt limits as per IEC-61800.		
20.05.00	Drive manufacturer shall coordinate with the motor manufacturer for proper selection of the motor for the given load application and the output characteristics of the drive.		
20.06.00	Other requirements of motor shall be as stipulated in technical chapter of Motors and driven equipment in Part-B of technical specifications.		
21.00.00	LT & HT CABLES		
21.01.00	Contractor's scope shall also include LT and HT cables suitable for VFD system and Motors.		
22.00.00	CONTROL AND PERFORMANCE REQUIREMENTS		
22.01.00	The VFD to provide an automatic current limiting feature to control motor currents during startup and provide a "soft start" torque profile for the motor load combination. Current and torque limit adjustments shall be provided to limit the maximum VFD output current and the maximum torque produced by the motor.		
22.02.00	It shall be possible to vary the speed of the drive and control it in either Local or Remote mode. Local / Remote selection shall be done from VFD panel unless otherwise specified.		
22.03.00	<p>Provision shall be kept for exchange of information between different VFD control system parameters thru PLC/DDCMIS.</p> <p>Man machine interface for (MV) VFD shall have one flat TFT monitor with keyboard (password protected) in the VFD room and a color laser printer for system alarm and monitoring located in control room.</p> <p>Parameter Monitoring:</p> <ul style="list-style-type: none"> - Input and output voltage of Drive - Input and output current of Drive - Motor speed - Input and output power frequency of Drive - Torque <ul style="list-style-type: none"> - Input and Output power of Drive system (covering transformer if applicable) - Output kWhr of Drive - Transformer (if applicable) temperature for alarm & trip. <ul style="list-style-type: none"> - Ambient temperature - Run/stop and local/remote status displayed 		
TALCHER THERMAL POWER PROJECT STAGE-III (2X660 MW) EPC PACKAGE	TECHNICAL SPECIFICATION SECTION – VI, PART-B BID DOC NO : CS-4540-001A-2	SUB-SECTION : B-03 VFD	PAGE 8 OF 11

CLAUSE NO.	TECHNICAL REQUIREMENTS			
22.04.00	Drive shall be equipped with a front mounted operator console panel consisting of a backlit alphanumeric display and a keypad with keys for parameterization and adjusting parameter. Control panel shall be operable with password for changing the protection setting, safety interlock etc.			
22.05.00	Operator console/Main Control Card shall have facility / port to connect external hardware such as Lap-Top etc. Console shall have facility for upload and download of all parameter settings from one drive to another drive for start up and operation.			
22.06.00	User-friendly licensed software for operation and fault diagnostic shall be loaded in the drive system panel before commissioning.			
23.00.00	PROTECTION FEATURES			
23.01.00	<p>The system offered shall incorporate adequate protection features as per IEC 61800-4: 2002 Table-8, properly coordinated for the drive control and for motor including following:</p> <ul style="list-style-type: none"> i) Converter transformer: short circuit, over current, earth fault & winding temperature high protection. ii) Incoming and outgoing line surge protection. iii) Under / over voltage protection iv) Phase loss, phase reversal, overload, negative phase sequence, locked rotor protection. v) Instantaneous Over current & Earth fault protection vi) Converter/Inverter module failure indication. vii) Over frequency/speed protection. viii) Ventilation failure indication & alarm. ix) Over temperature of VFD x) Bearing temperature protection. xi) System earth fault protection. xii) Speed reference loss protection. 			
23.02.00	Under VFD Bypass Mode (if applicable) all the electrical protections related to the Motor shall remain applicable.			
24.00.00	CONTROL FEATURES			
24.01.00	<p>Following controls shall be provided as a part of the Operator Control Panel or through separate switches on the front panel door.</p> <ul style="list-style-type: none"> i) Start / stop (in local/remote mode) ii) Speed control (Raise / lower) 			
TALCHER THERMAL POWER PROJECT STAGE-III (2X660 MW) EPC PACKAGE		TECHNICAL SPECIFICATION SECTION – VI, PART-B BID DOC NO : CS-4540-001A-2	SUB-SECTION : B-03 VFD	PAGE 9 OF 11

CLAUSE NO.	TECHNICAL REQUIREMENTS		
	iii) Acknowledge/Accept/ Test Push Button for annunciation iv) Auto / Manual / Test Mode select v) Emergency stop vi) Trip-Remote Breaker		
25.00.00	DIAGNOSTIC FEATURES		
25.01.00	The VFD shall include a microprocessor/PLC based digital diagnostic system which monitors its own control functions and displays faults and operating conditions.		
25.02.00	Fault diagnostic shall be built into the system to supervise the operation and failure of the system. The information regarding failure of any of the system including shut down of the system shall be available. It shall be possible to retrieve the record of events prior to tripping of the system or de-energization. Auxiliary supply to the system components or to the electronics (firmware) for the diagnostics / display shall be taken care of by the manufacturer for this purpose.		
26.00.00	SERVICEABILITY / MAINTAINABILITY		
26.01.00	Power Component Accessibility: All power components in the converter sections shall be designed for rack-out accessibility for ease of maintenance and to minimize repair downtime.		
26.02.00	Marking / Labeling: Sleeve type wire marker tags or other acceptable means of permanent identification shall be applied to power and control wiring. Individual labels shall be provided for all major components of the VFD system.		
27.00.00	NOT USED		
28.00.00	TESTS		
28.01.00	ROUTINE TESTS		
28.02.00	All acceptance and routine tests as envisaged in QA section shall be carried out. Charges for these shall be deemed to be included in the equipment price.		
28.02.00	TYPE TESTS		
28.02.00	LIST OF TYPE TESTS TO BE CONDUCTED		
28.02.00	The following type tests shall be conducted under this contract for MV VFD		
28.02.00	i) Overall efficiency determination of VFD system including transformer/ Harmonic filters etc at motor full load ii) Temperature rise test iii) Noise level iv) Harmonics of No load current.(Input/Output)		
28.02.00	LIST OF TESTS FOR WHICH REPORTS HAVE TO BE SUBMITTED		
28.02.00	The following type test reports shall be submitted for VFD Panels'		
TALCHER THERMAL POWER PROJECT STAGE-III (2X660 MW) EPC PACKAGE	TECHNICAL SPECIFICATION SECTION – VI, PART-B BID DOC NO : CS-4540-001A-2	SUB-SECTION : B-03 VFD	PAGE 10 OF 11

CLAUSE NO.	TECHNICAL REQUIREMENTS		
	<p>1) VFD panels (For LV VFD used with load \geq 50 KW)</p> <ul style="list-style-type: none"> i. Rated Current/ Output ii. Temperature rise test iii. Noise level test iv. Power Loss Determination Test v. Power factor measurement. vi. Degree of Protection Test vii. EMC Test viii. The Fast transient SWC tests as per ANSI / IEEE C37.901-2002 / IEC 60255-22-04-2008 / IEC 61800 <p>2) VFD panels (For MV VFD)</p> <ul style="list-style-type: none"> i. Rated Current/ Output ii. Current Sharing iii. Voltage Division iv. Power Loss Determination Test v. Power factor measurement. vi. Degree of Protection Test vii. The Fast transient SWC tests as per ANSI / IEEE C37.901-2002 / IEC 60255-22-04-2008 / IEC 61800 <p>3) AC/DC Reactor</p> <ul style="list-style-type: none"> i. Lightning impulse test(If applicable) ii. Heat run test iii. Short time current test(If applicable) iv. Noise level test <p>4) Transformers (for Non Integrated type)</p> <ul style="list-style-type: none"> i. As per requirements mentioned in subsection for Transformer chapter in technical specifications. 		
<p>TALCHER THERMAL POWER PROJECT STAGE-III (2X660 MW) EPC PACKAGE</p>	<p>TECHNICAL SPECIFICATION SECTION – VI, PART-B BID DOC NO : CS-4540-001A-2</p>	<p>SUB-SECTION : B-03 VFD</p>	<p>PAGE 11 OF 11</p>

CLAUSE NO.

QUALITY ASSURANCE



- (c) Butt welds in the tube/ separator /body casing of the mill shall be tested by UT / RT and MPI. All other welds in main tube/separator shall be tested by MPI/LPI for acceptance. The tube shall be statically balanced.
- (d) All gearboxes shall be run tested for adequate duration to check rise in oil temperature, noise level and vibration. Check for leak tightness of gear case also shall be performed.
- (e) Trail assembly (stacking) of at least one Mill complete with all major components needs to be carried out at shop.
- (f) Fabricated pipe welds should be examined by MPI.
- (g) Ceramic/basalt lined piping/bends shall be checked for proper layout.
- (h) Weldments on burner components shall be checked with suitable NDT. The burner assemblies shall be tested for operation at shop.

1.02.05

Coal Feeders

- (a) Any welds in the casing/ pulley fabrication shall be checked with MPI.
- (b) Type tests including degree of protection and routine tests shall be done as per relevant Indian Standards or equivalent International Standards.
- (c) All major items like plates for casings, head pulley, tail pulley, Pulley shaft and major casings shall be procured with respective material test certificates.
- (d) Leak tightness test shall be done on individual feeder casing. Functional test for load cell shall be carried out.
- (e) Test for weighing accuracy, calibration and repeatability shall be carried out at various speeds by a coal flow on one feeder.
- (f) Calibration check shall be carried out on all feeder cabinet/ assemblies prior to dispatch.

1.02.06

Fuel Oil Pumps

- (a) Bar stock/forging above 40 mm diameter shall be subjected to UT. Impeller and rotor shall be dynamically balanced.
- (b) Pump assemblies shall be subjected to hydraulic test.
- (c) All pumps including spare cartridges shall be subjected to performance test at the manufacturer's works under as near site conditions as possible and strip down examination after the test.

1.02.07

EOT CRANES

1.0 HOOKS

- 1.01 All Tests including Proof Load Test as per relevant IS shall be carried out.
- 1.02 MPI/DPT shall be carried out after proof load test.

CLAUSE NO.	QUALITY ASSURANCE		
	<p>2.0 STEEL CASTING</p> <p>2.01 DPT on machined surface shall be carried out.</p> <p>3.0 GIRDERS, END CARRIAGE, CRAB, GEAR BOX AND ROPE DRUM</p> <p>3.01 The plates of thickness 25mm and above shall be ultrasonically tested.</p> <p>3.02 NDT requirements on weldments shall be as follows:</p> <p>(a) BUTT WELDS IN TENSION :- 100% RT AND 100% DPT</p> <p>(b) BUTT WELDS IN COMPRESSION :- 10% RT AND 100% DPT</p> <p>(c) BUTT WELDS IN ROPE DRUM :- 100% RT AND 100% DPT</p> <p>(d) FILLET WELDS :- RANDOM 10% DPT</p> <p>4.0 FORGINGS (wheel, gears, pinions, axle, hooks & hook trunnion)</p> <p>4.01 All forgings greater than or equal to 50 mm diameter or thickness shall be subjected to Ultrasonic test.</p> <p>4.02 DPT/MPI shall be done after hard-facing and machining.</p> <p>5.0 Wire rope shall be tested as per relevant standard.</p> <p>6.0 Reduction gears shall be tested for reduction ratio, backlash & contact pattern. Gear box shall be subjected to no load run test to check for oil leakage, temperature rise, noise and vibration.</p> <p>7.0 The cranes shall be completely assembled at shop for final testing. All tests for dimension, deflection, load, overload, hoisting motion, cross travel etc. as per IS-3177 shall be carried out at shop.</p> <p>8.0 All electric hoists shall be tested as per IS-3938 and chain pulley blocks shall be tested as per IS-3832.</p>		
1.02.08	<p>Lube Oil systems/ Hydraulic Power Pack</p> <p>Lube Oil system/ hydraulic power packs shall be tested for performance.</p>		
1.02.09	<p>Fans & pumps which are not mentioned in other clauses above shall be dynamically balanced and functionally tested at Manufacturer's works. Complete performance tests shall be carried out on inlet pump/fan of each type and capacity to verify its output against total head, power input, efficiency, vibration and noise level. Head/volume, efficiency and power input curves corrected for site conditions shall be furnished.</p>		
1.02.10	<p>Dampers</p> <p>(a) All the dampers shall be subjected to operational test/checks.</p> <p>(b) Leak tightness of test of Dampers / Gates shall be carried out as given in respective subsection of Technical Requirements of Steam Generator & Auxiliaries.</p> <p>(c) All dampers shall be checked for sealing dimensions to establish guaranteed tightness.</p>		
<p>TALCHER THERMAL POWER PROJECT STAGE-III (2X660 MW) EPC PACKAGE</p>	<p>TECHNICAL SPECIFICATION SECTION-VI, PART-B BID DOC NO.:CS-4540-001A-2</p>	<p>SUB-SECTION-E-1 STEAM GENERATOR AND AUXILIARIES</p>	<p>Page 10 of 13</p>

Shop Test for T.G.Hall EOT Cranes, Other Cranes & Hoist

1.0**HOOKS**

1.01

ALL TESTS INCLUDING PROOF LOAD TEST AS PER RELEVANT IS/BS/DIN SHALL BE CARRIED OUT.

1.02

MPI/DPT SHALL BE CARRIED OUT AFTER PROOF LOAD TEST.

2.0**STEEL CASTING**

2.01

DPT ON MACHINED SURFACE SHALL BE CARRIED OUT.

3.0**GIRDERS, END CARRIAGE, CRAB, GEAR BOX AND ROPE DRUM**

3.01

THE PLATES OF THICKNESS 20MM AND ABOVE SHALL BE ULTRASONICALLY TESTED.

3.02

NDT REQUIREMENTS ON WELDMENTS SHALL BE AS FOLLOWS:

- a) BUTT WELDS IN TENSION:- 100% RT AND 100% DPT
- b) BUTT WELDS IN COMPRESSION:- 10% RT AND 100% DPT
- c) BUTT WELDS IN ROPE DRUM:- 100% RT AND 100% DPT
- d) FILLET WELDS:- RANDOM 10% DPT

4.0**FORGING (WHEEL, GEARS, PINIONS, AXLE, HOOKS & HOOK TRUNION)**

4.01

ALL FORGINGS GREATER THAN OR EQUAL TO 50 MM DIAMETER OR THICKNESS SHALL BE SUBJECTED TO ULTRASONIC TESTING.

4.02

DPT/MPI SHALL BE DONE AFTER HARDFACING AND MACHINING.

5.0

WIRE ROPE SHALL BE TESTED AS PER RELEVANT STANDARD.

6.0

REDUCTION GEARS SHALL BE TESTED FOR REDUCTION RATIO, BACKLASH & CONTACT PATTERN. GEAR BOX SHALL BE SUBJECTED TO NO-LOAD RUN TEST TO CHECK FOR OIL LEAKAGE, TEMPERATURE RISE, NOISE AND VIBRATION.

7.0

THE CRANES SHALL BE COMPLETELY ASSEMBLED AT SHOP FOR FINAL TESTING. ALL TESTS FOR DIMENSION, DEFLECTION, LOAD, OVERLOAD, HOISTING MOTION, CROSS TRAVEL ETC. AS PER IS-3177 SHALL BE CARRIED OUT AT SHOP.

8.0

ALL ELECTRIC HOISTS SHALL BE TESTED AS PER IS-3938 AND CHAIN PULLEY BLOCKS SHALL BE TESTED AS PER IS-3832.

9.0**LIFTING BEAM:**

9.01

THE PLATES OF THICKNESS 20MM AND ABOVE SHALL BE ULTRASONICALLY TESTED.



9.02

NDT REQUIREMENTS ON WELDMENTS SHALL BE AS FOLLOWS:

- e) BUTT WELDS IN TENSION:- 100% RT AND 100% DPT
- f) BUTT WELDS IN COMPRESSION:- 10% RT AND 100% DPT
- g) FILLET WELDS:- RANDOM 10% DPT

9.03

ALL FORGINGS GREATER THAN OR EQUAL TO 50 MM DIAMETER OR THICKNESS SHALL BE SUBJECTED TO ULTRASONIC TESTING.

9.04

DPT/MPI SHALL BE DONE AFTER MACHINING.

9.05

Lifting Beam will be subjected to overload testing at @1.25 X SWL of Lifting Beam at manufacturer works.

CLAUSE NO.	TECHNICAL REQUIREMENTS			
	d) Chequered plate shall conform to IS 3502 and shall be minimum 6 mm thick excluding projection. Steel for chequered plate shall conform to grade E250A semi killed of IS: 2062 or equivalent grade conforming to ASTM & BS standards only.			
10.04.02	<p>Medium and High Tensile Steel</p> <p>Rolled Sections and plates shall be of grade designation E350 or higher, Quality B0 (Fully killed), conforming to IS: 2062. Plates beyond 12mm thickness and up to 40mm thickness shall be normalized rolled. Plates beyond 40mm thickness shall be vacuum degassed & furnace normalised and shall also be 100% ultrasonically tested as per ASTM –A578 level B-S2.</p>			
10.05.00	<p>Bricks</p> <p>Only fly ash bricks shall be used in all construction, except for elevator shafts, which can be either of burnt clay bricks or RCC construction as per functional / codal provisions. Bricks shall be table moulded/ machine made of uniform size, shape and sharp edges and shall have minimum compressive strength of 75kg/cm². Burnt clay fly ash bricks and fly ash lime bricks shall conform to IS: 13757 and IS: 12894 respectively. Minimum fly ash content in fly ash based bricks shall be 25%.</p>			
10.06.00	<p>Foundation Bolts</p> <p>Material and details of foundation bolts shall conform to IS: 5624. Mild steel bars used for the fabrication of bolt assembly shall conform to grade 1 of IS: 432 and/ or grade A of IS: 2062. Hexagonal nuts and lock nuts shall conform to IS: 1363 & IS: 1364 upto M36 diameter and IS: 5624 for M42 to M150 diameter.</p>			
10.07.00	<p>Stainless steel</p> <p>The material specification for stainless steel plates are mentioned in the design concept area of Mill Bunker building.</p>			
10.08.00	<p>Water</p> <p>Water used for cement concrete, mortar, plaster, grout, curing, washing of coarse aggregate, soaking of bricks, etc. shall be clean and free from oil, acids, alkalis, organic matters or other harmful substances in such amounts that may impair the strength or durability of the structure. Potable water shall generally be considered satisfactory for all masonry and concrete works, including curing. When water from the proposed source is used for making the concrete, the maximum permissible impurities, development of strength and initial setting time of concrete shall meet the requirements of IS: 456.</p> <p>All materials brought for incorporation in works shall be of best quality as per IS unless specified otherwise.</p>			
10.09.00	<p>PTFE (Poly Tetra Fluoroethylene) Bearing</p> <p>The bearing shall be of reputed make and manufacturer as approved by the Engineer, for required vertical load and end displacement/rotation. PTFE bearing shall be sliding against highly polished stainless steel and the coefficient of friction between them shall be less than 0.06 at 55 kg/sq.cm. In order to prevent cold flow in PTFE surface it shall be rigidly bonded by a special high temperature resistance adhesive to the stainless steel substrata. The stainless steel surface that slides against the PTFE is mirror polished. The stainless steel shall be bonded to the top plate by special high strength adhesive. The thickness of stainless steel plate shall be between 1.0 mm to 1.5 mm.</p>			
10.10.00	<p>Statutory Requirements</p> <p>Bidder shall comply with all the applicable statutory rules pertaining to Factories Act, Fire Safety Rules at Tariff Advisory Committee. Water Act for pollution control, Explosives Act, etc. Provisions of safety, health and welfare according to Factories Act shall be complied with.</p>			
TALCHER THERMAL POWER PROJECT STAGE-III (2X660 MW) EPC PACKAGE		TECHNICAL SPECIFICATION SECTION-VI, PART-B BID DOC NO.:CS-4540-001A-2	SUB-SECTION-D-1-10 CIVIL WORKS MATERIAL SPECIFICATION	PAGE 3 OF 4





SUB-SECTION-A-12

SURFACE PREPARATION & PAINTING

**TALCHER THERMAL POWER PROJECT
STAGE-III (2X660 MW)
EPC PACKAGE**

**TECHNICAL SPECIFICATION
SECTION-VI, PART-B
BID DOC. NO. CS-4540-001A-2**

CLAUSE NO.	<div style="text-align: right;"></div> TECHNICAL REQUIREMENTS		
1.00.00	Specification of surface preparation & painting		
1.01.00	Surface preparation methods and paint/primer materials shall be of the type specified herein. If the contractor desires to use any paint/primer materials other than that specified, specific approval shall be obtained by the contractor in writing from the employer for using the substitute material.		
1.02.00	All paints shall be delivered to job site in manufacturers sealed containers. Each container shall be labelled by the manufacturer with the manufacturer's name, type of paint, batch number and colour.		
1.03.00	Unless specified otherwise, paint shall not be applied to surfaces of insulation, surfaces of stainless steel/nickel/ copper/brass/ monel/ aluminum/ hastelloy/lead/ galvanized steel items, valve stem, pump rods, shafts, gauges, bearing and contact surfaces, lined or clad surfaces.		
1.04.00	All pipelines shall be Colour coded for identification as per the NTPC Colour-coding scheme, which will be furnished to the contractor during detailed engineering.		
1.05.00	SURFACE PREPARATION		
1.05.01	All surfaces to be painted shall be thoroughly cleaned of oil. Grease and other foreign material. Surfaces shall be free of moisture and contamination from chemicals and solvents.		
1.05.02	<p>The following surface preparation schemes are envisaged here. Depending upon requirement any one or a combination of these schemes may be used for surface preparation before application of primer.</p> <p>SP1 Solvent cleaning</p> <p>SP2 Application of rust converter (Ruskil or equivalent grade)</p> <p>SP3 Power tool cleaning</p> <p>SP4 Shot blasting (shot blasting shall be used as surface preparation method for hot worked pipes prior to application of primer)</p> <p>SP4* Shot blast cleaning/ abrasive blast cleaning to SA21/2 (near white metal) 35-50 microns</p> <p>SP5 Shot blasting/ abrasive blasting.</p> <p>SP6 Emery sheet cleaning/Manual wire brush cleaning.</p>		
1.06.00	APPLICATION OF PRIMER/PAINT		
1.06.01	The paint/primer manufacturer's instructions covering thinning, mixing, method of application, handling and drying time shall be strictly followed and considered as part of this specification. The Dry film thickness (DFT) of primer/paint shall be as specified herein.		
1.06.02	Surfaces prepared as per the surface preparation scheme indicated herein shall be applied with primer paint within 6 hours after preparation of surfaces.		
1.06.03	Where primer coat has been applied in the shop, the primer coat shall be carefully examined, cleaned and spot primed with one coat of the primer before applying intermediate and finish coats. When the primer coat has not been applied in the shop, primer coat shall be applied by brushing, rolling or spraying on the same day as the surface is prepared. Primer coat shall be applied prior to intermediate and finish coats.		
1.06.04	Steel surfaces that will be concealed by building walls shall be primed and finish painted before the floor is erected. Tops of structural steel members that will be covered by grating shall be primed and finish painted before the grating is permanently secured.		
TALCHER THERMAL POWER PROJECT STAGE-III (2X660 MW) EPC PACKAGE	TECHNICAL SPECIFICATION SECTION VI, PART-B BID DOC. NO. CS-4540-001A-2 Page 64 of 368	SUB-SECTION - A-12 SURFACE PREPARATION & PAINTING	Page 1 of 8

CLAUSE NO.	 TECHNICAL REQUIREMENTS		
1.06.05	<p>Following are the Primer/painting schemes envisaged herein:</p> <p>PS3 - Zinc Chrome Primer (Alkyd base) by brush/Spray to IS104.</p> <p>PS3* - Zinc Chrome primer (Alkyd base) by dip coat.</p> <p>PS4 - Synthetic Enamel (long oil alkyd) to IS2932.</p> <p>PS5 - Red Oxide Zinc Phosphate primer (Alkyd base) to IS 12744</p> <p>PS9 - Aluminum paint to IS 2339.</p> <p>PS9* - Heat resistant Aluminum paint to IS-13183 Gr.-I (for temperature 400 degC – 600 degC), IS-13183 Gr.-II (for temperature 200 degC- 400 degC and IS-13183 Gr.-III (for temperature upto 200 degC)</p> <p>PS13 - Rust preventive fluid by spray, dip or brush.</p> <p>PS14 - Weldable primer-Deoxaluminat or equivalent.</p> <p>PS16 - High Build Epoxy CDC mastic `15'.</p> <p>PS17 - Aliphatic Acrylic Polyurethane CDE134, %V=40.0(min.)</p> <p>PS18 - Epoxy based TiO2 pigmented coat</p> <p>PS19 - Epoxy Zinc rich primer (92% zinc in dry film (min.), %VS=35.0(min.)</p> <p>PS-20 - Epoxy based finish paint</p>		
1.06.06	All weld edge preparation for site welding shall be applied with one coat of weldable primer.		
1.06.07	For internal protection of pipes/tubes, VCI pellets shall be used at both ends after sponge testing and ends capped. VCI pellets shall not be used for SS components and composite assemblies.		
1.06.08	SG membrane walls and other Flue gas swept pressure part surfaces shall be applied with appropriate primer for protection of surfaces during transit, storage and erection.		
1.06.09	<p>a) All un-insulated equipments, pipes, valves etc covered in sub-section A-08 (Steam Turbine & Auxiliary system) shall be painted with paint not inferior to Epoxy resin based paints with minimum DFT of 150 micron.</p> <p>The paint shall be applied in three stages i.e. primer, intermediate and finish coats in following manner:</p> <ul style="list-style-type: none"> ▪ Primer coat – Epoxy based zinc phosphate ▪ Intermediate - Epoxy based TiO2 pigmented coat ▪ Finish coat - Epoxy based finish coat/Two pack polyurethane coat <p>b) Equipment, pipes etc. with high temperature shall be painted with heat resistant aluminum paint (to be selected based on the service condition of component as per IS-13183). Two coats of paint shall be applied with total DFT 40 micron.</p> <p>c) Surface preparation before painting shall be carried out according to requirement indicated in this sub-section and international standard</p>		
1.06.10 A)	<p>Specification for the application of Epoxy coating for internal protection of DM tank & other vessels/tanks (as applicable) shall be as follows:</p> <p>Primer : One coat of unmodified epoxy resin along with polyimide hardener.</p> <p>Paint : Two (2) coats unmodified epoxy resin along with Aromatic adduct</p>		
TALCHER THERMAL POWER PROJECT STAGE-III (2X660 MW) EPC PACKAGE	TECHNICAL SPECIFICATION SECTION VI, PART-B BID DOC. NO. CS-4540-001A-2 Page 65 of 368	SUB-SECTION - A-12 SURFACE PREPARATION & PAINTING	Page 2 of 8

CLAUSE NO.	TECHNICAL REQUIREMENTS 		
	<p style="text-align: center;">hardener.</p> <p>Total thickness of primer and paint should not be less than 400 microns.</p> <p>B) Specification for application of chlorinated Rubber paint for external protection vessel, tanks, piping, valves & other equipments shall be as follows:</p> <p>i) For Indoor vessel, tanks, piping, valves & other equipments:</p> <ul style="list-style-type: none"> (a) Surface preparation shall be done either manually or by any other approved method. (b) Primer coat shall consist of one coat of chlorinated rubber based zinc phosphate primer having minimum DFT of 50 microns. (c) Intermediate coat (or under coat) shall consist of one coat of chlorinated rubber based paint pigmented with Titanium dioxide with minimum DFT of 50 microns. (d) Top coat shall consist of one coat of chlorinated rubber paint of approved shade and colour with glossy finish and DFT of 50 microns. <p style="text-align: center;">Total DFT of paint system shall not be less than 150 microns.</p> <p>ii) For Outdoor vessel, tanks, piping, valves & other equipments:</p> <ul style="list-style-type: none"> (a) Surface preparation shall be blast cleared using non-siliceous abrasive after usual wire brushing, which shall conform to Sa 2-1/2 Swiss Standard. (b) Primer coat shall consist of one coat of epoxy resin based zinc phosphate primer having minimum DFT of 100 microns. (c) Intermediate coat (or under coat) shall consist of epoxy resin based paint pigmented with Titanium dioxide with minimum DFT of 100 microns. (d) Top coat shall consist of one coat of epoxy paint suitable pigmented of approved shade and colour with glossy finish and DFT of 75 microns. Additionally finishing coat of polyurethane of minimum DFT of 25 microns shall be provided. <p>The paint may be applied in one coat, in case high built paint is used, otherwise two coats shall be applied.</p> <p style="text-align: center;">Total DFT shall not be less than 300 microns.</p>		
TALCHER THERMAL POWER PROJECT STAGE-III (2X660 MW) EPC PACKAGE	TECHNICAL SPECIFICATION SECTION VI, PART-B BID DOC. NO. CS-4540-001A-2 Page 66 of 368	SUB-SECTION - A-12 SURFACE PREPARATION & PAINTING	Page 3 of 8



1.06.11 Primer/Painting Schedule

Sl. No	Description	Surface Preparation	Primer Coat			Intermediate Coat			Finish Coats			Total Min. Painting DFT (Microns)	Colour Shade
			Type of Primer	No. of Coats	Min. DFT / coat (Microns)	Type of coating	No. Coats	Min. DFT/ Coat (Microns)	Type of coating	No. Coats	Min. DFT/ Coat (Microns)		
A) Power Cycle Piping													
1.	All insulated Piping, fittings/ components, Pipe clamps, Vessels/Tanks, Equipments etc.	SP3/SP4	PS9*	1	20	-	-	-	PS9*	1	20	40	As per NTPC Colour shade/ coding scheme
2.	All un-insulated Piping, fittings/ components, Pipe clamps, Vessels/Tanks, Equipment etc.	Design temperature < or equal to 60°C	SP3/SP4	PS 5	2	25	-	-	PS 4	3	35	155	
		Design temperature above 60°C- 200°C	SP3/SP4	PS 9*	1	20	-	-	PS9*	1	20	40	
		Design temperature > 200°C	SP3/SP4	PS9*	1	20	-	-	PS9*	1	20	40	
3	Constant Load Hanger (CLH) and Variable Load Hanger (VLH)	SP4*	PS19	1	40	-	-	-	PS17	1	30	70	
4	Piping hangers / supports (other than (3) above. (un-insulated)	SP3/SP5	PS5	2	25	-	-	-	PS4	2	25	100	

TALCHER THERMAL POWER PROJECT
STAGE-III (2X660 MW)
EPC PACKAGE

BID DOC. NO. CS-4540-001A-2

TECHNICAL SPECIFICATION
SECTION VI, PART-BSUB-SECTION -A-12
SURFACE PREPARATION &
PAINTING

Page 4 of 8



Valves													
5.	Cast/Forged	Design temperature < or equal to 60 degC #	SP3/SP5	PS5	2	35	-	-	-	PS4	2	25	120
		Design temperature above 60 degC	SP3/SP5	PS9*	1	20	-	-	-	PS9*	1	20	40
6.	All auxiliary Structural Steel components for pipe supports	Outside building and in SG envelope TG	SP4*	Inorganic Ethyl Zinc Silicate	1	75	PS18	1	75	a) Epoxy coat b) Final coat of paint PS17	2 1	35 30	250
		Within building TG	SP4*	-do-	1	35	PS18	1	35	a) Epoxy coat b) Final coat of paint PS17	2 1	25 30	150
7.	Weld Edges		SP6 (Hand cleaning by wire brushing)	PS13 (Weldable primer)	1	25	-	-	-	-	-	-	25

TALCHER THERMAL POWER PROJECT STAGE-III (2X660 MW) EPC PACKAGE	BID DOC. NO. CS-4540-001A-2	TECHNICAL SPECIFICATION SECTION VI, PART-B	SUB-SECTION -A-12 SURFACE PREPARATION & PAINTING	Page 5 of 8
--	-----------------------------	---	--	-------------



1. \$ - The first 2 finished coats (total min.DFT of 70 microns) shall be done at shop and the 3rd finish coat (min.DFT 35 Microns) shall be applied at site.
2. For valves below 65NB and temperature upto and including 540 DegC, Parkerizing/zinc phosphate corrosion resistant coating as per ASTM F1137 is also acceptable in lieu of Aluminum paint.
3. For corrosion protection of threaded hanger rods and variable spring cages, electro galvanizing in full compliance to minimum Corrosion category C3 as per EN ISO12944 is also acceptable.
4. For spring cages, 2 coats of 30 µm (min) zinc-rich epoxy resin primer with zinc content > 80 weight% in dry film followed by 2 coats of 30 µm (min) top coat of Acrylic resin Co-polymerisate with a total combined minimum DFT of 120µm is also acceptable in lieu of above specified paint scheme.
5. For corrosion protection, all inner parts of the hangers (CLH/VLH) shall be at least in full compliance to Corrosion category C3 as per EN ISO12944.
6. # - For Cast/forged valves upto & including design temperature 60Deg.C, Aluminium painting as per IS-13183 Gr-3 or better with total DFT 40Micron is also acceptable.

B) Steam Generator & Auxiliaries:

1	All surfaces with temperature 95°C or less and which are insulated	SP3/SP4	PS 5	2	30	-	-	-	PS 4	2	20	100
2	All surfaces with temperature above 95°C and which are insulated	SP3/SP4	PS9*	1	20	-	-	-	PS9*	1	20	40

Note: 1) SG membrane walls and other Flue gas swept pressure part surfaces shall be applied with appropriate primer for protection of surfaces during transit, storage and erection.

2) Painting specification for all other exposed steel surfaces not covered above shall be same as that given in Civil Sub-section, Part-B, Section VI for corrosion protection of steel structures.

TALCHER THERMAL POWER PROJECT STAGE-III (2X660 MW) EPC PACKAGE	BID DOC. NO. CS-4540-001A-2	TECHNICAL SPECIFICATION SECTION VI, PART-B	SUB-SECTION -A-12 SURFACE PREPARATION & PAINTING	Page 6 of 8
--	-----------------------------	---	--	-------------



C) LOW PRESSURE PIPING													
1	All Piping, fittings / components, valves, Equipments etc.	SP3/SP5	PS3/PS5	2	25	PS 4	1	30	PS 4	2	35	150	As per NTPC Color shade/coding scheme.
2	Stainless steel surface, Galvanized steel surface and gun metal surface.	No Painting											
3	On the internal surface for pipes 1000 Nb and above	A coat of primer followed by hot coal-tar enamel or coal tar epoxy painting (cold) shall be applied.											
D) Fire Detection & Protection System, Compressed air system and Air-conditioning & Ventilation System													
<p>For Fire Detection & Protection System, Surface preparation and painting of Fire Water Storage Tanks, all Steel Surfaces (external) exposed to atmosphere (outdoor & indoor installation), Deluge Valves, Alarm Valves, Foam monitors, Water monitors, Foam Proportioning equipments, Foam makers, etc. should be as per the Part-B, Sub Section-A-18, Fire Detection & Protection System</p> <p>For Air Conditioning System, Surface preparation and painting of all the steel surfaces (external) exposed to atmosphere (outdoor & indoor installation), centrifugal fans – Casing etc. should be as per the Part-B, Sub Section-A-17, Air Conditioning System.</p> <p>For Ventilation System, Surface preparation and painting of all the steel surfaces (external) exposed to atmosphere (outdoor & indoor installation), centrifugal fans – Casing etc. should be as per the Part-B, Sub Section-A-17, Ventilation System.</p> <p>For compressed air system, Surface preparation and painting of all the steel surfaces should be as per the Part-B, Sub Section--A-16 compressed air system.</p>													
E) ESP													
1	All surfaces with surface temperature 95°C or less (with or without insulation)	SP3/SP4	PS3/PS3*	1	25	-	-	-	PS 4	1	30	55	
2	All surfaces with surface temperature above 95°C (with or without insulation)	SP3/SP4	PS5	2	30	-	-	-	-	-	-	60	

TALCHER THERMAL POWER PROJECT STAGE-III (2X660 MW) EPC PACKAGE	BID DOC. NO. CS-4540-001A-2	TECHNICAL SPECIFICATION SECTION VI, PART-B	SUB-SECTION -A-12 SURFACE PREPARATION & PAINTING	Page 7 of 8
--	-----------------------------	---	--	-------------



General Notes (Applicable for all above points A to E)

- i) Painting specification for all surfaces with surface temperature 95°C or less (un-insulated) that are not covered above shall be same as that given in Civil Sub-section, Part-B, Section-VI for corrosion protection of steel structures.
- ii) Painting specification for inside surfaces (such as inner surfaces of ducts/ tanks/ mills/ dampers/ ESP etc.) that are not covered specifically in above clauses, shall be provided with 2 coats of suitable primer i.e. PS5/ PS9 (Total DFT 60/40 micron) based on the temperature.

F) FGD System

- (i) Surface preparation shall be blast cleaned conforming to Sa 2-1/2 Swiss Standard.
- (ii) Primer coat shall consist of epoxy resin based zinc phosphate primer having minimum DFT of 100 microns.
- (iii) Intermediate coat (or under coat) shall consist of epoxy resin based paint pigmented with Titanium dioxide with minimum DFT of 100 microns.
- (iv) Top coat shall consist of one coat of epoxy paint suitable pigmented of approved shade and colour with glossy finish and DFT of 75 microns. Additionally finishing coat of polyurethane of minimum DFT of 25 microns shall be provided.

TALCHER THERMAL POWER PROJECT STAGE-III (2X660 MW) EPC PACKAGE	BID DOC. NO. CS-4540-001A-2	TECHNICAL SPECIFICATION SECTION VI, PART-B	SUB-SECTION -A-12 SURFACE PREPARATION & PAINTING	Page 8 of 8
--	-----------------------------	---	--	-------------

		SCOPE OF SUPPLY AND SERVICES		
1.20.00	2.	Following requirements of construction power for employers' office/ construction use: Construction power at 415 V at two locations with total load 100 KVA along with suitable metering arrangement at each location.		
1.21.00	Deleted			
1.22.00	OVERHEAD LINES	Transmission line to AWRS Pumphouse: Two number 11kV or 33kV single circuit transmission line on poles for supplying power from plant to AWRS pumphouse The overhead lines for AWRS Pump house shall generally be laid along the AWRS route. However, exact routing shall be decided during detailed engineering. Scope of work includes route survey for line, civil works, design, supply, erection and commissioning of poles.		
	PAINTING FOR ELECTRICAL EQUIPMENT	Unless explicitly stated in relevant chapters of the specification, the painting of all electrical equipment shall be as follows: The thickness of finish coat shall be minimum 50 microns (minimum total DFT shall be 100 microns). However, in case electrostatic process of painting is offered for any electrical equipment, minimum paint thickness of 50 microns shall be acceptable for finish coat. In case procedure is not indicated, Epoxy based paint with suitable additives shall be used. Paint shade for various Equipment shall be as follows		
		SI no.	Item Description	Procedure
		1.	Generator and Auxiliaries	-
		2.	Motors	-
		3.	VFD Transformer and Reactor Enclosures	-
		4.	VFD Panels	-
		5.	Transformers and Oil Tanker	a) Inside of Tank and Accessories- Oil and Heat Resistant b) External surface of transformer and accessories- Chemical resistant epoxy zinc phosphate primer, MIO (Micaceous iron oxide) as intermediate paint followed by polyurethane finish paint.
		6.	Transformers-Cooler & Radiators	a) External surface- ISO 12944-5:2018, Table D.1, System no. G5.05
TALCHER THERMAL POWER PROJECT STAGE- III (2X660 MW) EPC PACKAGE		TECHNICAL SPECIFICATION SECTION – VI, PART-A BID DOC NO. : CS-4540-001A-2		SUB-SECTION-IIB ELECTRICAL SYSTEM / EQUIPMENTS
				PAGE 13 OF 17

1236331/2023/PS-PEM-MAX

	TITLE	SPECIFICATION NO. PE-TS-497-501-A501	
	2x660MW TALCHER TPP STAGE-III	REV 00	
	DOUBLE GIRDER EOT CRANES ABOVE 100T	Section IA	Date DEC'22
	SPECIFIC TECHNICAL REQUIREMENTS		

SECTION – IA

ANNEXURES

	TITLE	SPECIFICATION NO. PE-TS-497-501-A501
	2x660MW TALCHER TPP STAGE-III	REV 00
	DOUBLE GIRDER EOT CRANES ABOVE 100T SPECIFIC TECHNICAL REQUIREMENTS	Section IA Date DEC'22

ANNEXURE-I
MAKES OF SUB-VENDOR ITEMS

SR. NO.	ITEM	SUPPLIERS	PLACE	REMARKS
1.	STEEL	SAIL		
		TISCO		
		JINDAL		
		ESSAR		
2.	HOOKS	STEEL FORGING & ENGG. CO.,	KOLKATA	
		SIMRITI FORGING		
		KARACHIWALA		UP TO 25T CAPACITY
3.	GEAR COUPLINGS	ALLIANCE		
		FLEX-TRANS (formerly known as HICLIFF)		
		SAHARA		
		NUTECH		
		OEM		
4.	WIRE ROPE	USHA MARTIN		
		FORT WILLIAMS		
		BHARAT WIRE ROPES		
5.	BEARINGS	SKF		
		FAG		
		TATA		
		NBC		
6.	MOTORS	SIEMENS		
		NGEF (up to 15KW)		
		CROMPTON		
		KIRLOSKAR		
		BHARAT BIJLI		
		MARATHON		
7.	BRAKES	ELECTROMAG		
		SPEED-O- CONTROL		
		BCH		FOR DCEM BRAKES ONLY
		KAKKU		
		PATHE		
8.	CONTACTOR	SIEMENS		
		L&T		
		SCHNEIDER (Earlier TELE MECHANIQUE)		
		BCH		
9.	OVER LOAD RELAYS	SIEMENS		
		L&T		
		ABB		
		SCHNEIDER (Earlier TELE MACHANIQUE)		

	TITLE	SPECIFICATION NO. PE-TS-497-501-A501
	2x660MW TALCHER TPP STAGE-III	REV 00
	DOUBLE GIRDER EOT CRANES ABOVE 100T SPECIFIC TECHNICAL REQUIREMENTS	Section IA Date DEC'22

SR. NO.	ITEM	SUPPLIERS	PLACE	REMARKS
10.	HRC FUSES	SIEMENS		
		L&T		
		ENGLISH ELECTRIC		
		GE POWER		
		EATON (BUSSMANN)		
11.	ISOLATING SWITCH	ABB		
		SIEMENS		
		L&T		
		CONTROL & SWITCH GEAR		
		ABB		
12.	SWITCH FUSE UNITS	SIEMENS		
		L&T		
		CONTROL & SWITCH GEAR	-	
		ABB		
13.	TIME DELAY RELAYS	SIEMENS		
		L&T		
		ABB		
		BCH		
		SCHNEIDER (Earlier TELE MACHANIQUE)		
14.	TRANSFORMERS	INDCOIL		
		LOGICSTAT		
		KAPPA		
		AUTOMATIC ELECTRIC		
		PRECISE ELECTRICALS		
		SILKAAN ELECTRIC MFG. CO. LTD.		
		SOUTHERN ELECTRIC		
15.	BULB & FLOURESCENT TUBES/FITTINGS	NEC		
		PHILIPS		
		BAJAJ		
16.	CABLE LUGS (HEAVY DUTY)	CROMPTON		
		DOWELLS		
		UML ENGINEERS	KOLKATA	
17.	HOOTERS	JAINSON		
		BEACON		
		OSC		
		TARGET		
18.	LIGHTING SWITCHES	KHERAJ		
		ANCHOR		
		ELLORA		
		BAJAJ		
19.	PVC POWER CABLES	PHILIPS		
		APAR INDUSTRIES LTD.	MUMBAI	
		CORDS CABLE INDUSTRIES LTD.	NEW DELHI	

	TITLE	SPECIFICATION NO. PE-TS-497-501-A501
	2x660MW TALCHER TPP STAGE-III	REV 00
	DOUBLE GIRDER EOT CRANES ABOVE 100T SPECIFIC TECHNICAL REQUIREMENTS	Section IA Date DEC'22

SR. NO.	ITEM	SUPPLIERS	PLACE	REMARKS
		DIAMOND POWER INFRASTRUCTURE LTD	VADODARA	
		GOYOLENE FIBRES (INDIA) PVT.LTD	MUMBAI	
		GOVIND CABLE INDUSTRIES	KOLKATA	
		GUPTA POWER INFRASTRUCTURE LIMITED	BHUBNESWAR	
		HAVELLS INDIA LIMITED	NOIDA	
		KEI INDUSTRIES LTD.	NEW DELHI	
		KRISHNA ELECTRICAL INDUSTRIES LTD	GWALIOR	
		KEC INTERNATIONAL LIMITED	MUMBAI	
		MANSFIELD CABLES COMPANY LTD.	NOIDA	
		NICCO CORPORATION LTD.	KOLKATA	
		PARAMOUNT COMMUNICATIONS LTD.	NEW DELHI	
		POLYCAB WIRES PVT. LTD.	MUMBAI	
		RADIANT CORPORATION PRIVATE LIMITED	HYDERABAD	
		RAVIN CABLES LIMITED	MUMBAI	
		SUYOG ELECTRICALS LTD.	VADODARA	
		SRIRAM CABLES PVT. LTD.	NEW DELHI	
		SCOT INNOVATION WIRES AND CABLES PVT. LTD.	SOLAN	
		SAM CABLES & CONDUCTORS (P) LTD	UDHAM SINGH NAGAR	
		THERMO CABLES LTD	HYDERABAD	
		ADVANCE CABLE TECHNOLOGIES (P) LTD	BANGALORE	
		APAR INDUSTRIES LTD., CMI LTD	MUMBAI	
		CMI LIMITED	FARIDABAD	
		CORDS CABLE INDUSTRIES LTD	NEW DELHI	
		CRYSTAL CABLE INDUSTRIES LTD	KOLKATA	
		DELTON CABLES LTD	NEW DELHI	
		DIAMOND POWER INFRASTRUCTURE LTD	VADODARA	
		ELKAY TELELINKS LTD	NEW DELHI	
		GEMSCAB INDUSTRIES LTD	NEW DELHI	
		GOVIND CABLE INDUSTRIES	KOLKATA	
		GUPTA POWER INFRASTRUCTURE LIMITED	BHUBNESWAR	
		HAVELLS INDIA LIMITED	NOIDA	
		INCOM CABLES (P) LTD	NEW DELHI	
		KEI INDUSTRIES LTD	NEW DELHI	
20.	PVC CONTROL CABLES			

	TITLE	SPECIFICATION NO. PE-TS-497-501-A501
	2x660MW TALCHER TPP STAGE-III	REV 00
	DOUBLE GIRDER EOT CRANES ABOVE 100T SPECIFIC TECHNICAL REQUIREMENTS	Section IA Date DEC'22

SR. NO.	ITEM	SUPPLIERS	PLACE	REMARKS
		KRISHNA ELECTRICAL INDUSTRIES LTD	GWALIOR	
		KEC INTERNATIONAL LIMITED	MUMBAI	
		MANSFIELD CABLES COMPANY LTD	NOIDA	
		NICCO CORPORATION LTD	KOLKATA	
		PARAMOUNT COMMUNICATIONS LTD	NEW DELHI	
		POLYB WIRES PVT. LTD	MUMBAI	
		RAVIN CABLES LIMITED	MUMBAI	
		SUYOG ELECTRICALS LTD	VADODARA	
		SPECIAL CABLES PVT. LTD	NEW DELHI	
		SCOT INNOVATION WIRES AND CABLES PVT. LTD	SOLAN	
		SAM CABLES & CONDUCTORS (P) LTD	UDHAM SINGH NAGAR	
		SPM POWER & TELECOM PVT. LTD	HYDERABAD	
		TORRENT CABLES LTD	AHMEDABAD	
		THERMO CABLES LTD	HYDERABAD	
		TIRUPATI PLASTOMATICS PVT. LTD	JAIPUR	
		UNIVERSAL CABLES LTD	SATNA	
21.	TRAILING CABLES	NICCO	KOLKATA	
		UNIVERSAL	SATNA	
		INCAB		
		ICL	NEW DELHI	
		APAR INDUSTRIES LTD	MUMBAI	
		CMI LTD	FARIDABAD	
		KEI INDUSTRIES LTD	NEW DELHI	
		SUYOG ELECTRICALS LTD	VADODARA	
22.	XLPE POWER CABLES	APAR INDUSTRIES LTD	MUMBAI	
		CORDS CABLE INDUSTRIES LTD	NEW DELHI	
		CRYSTAL CABLE INDUSTRIES LTD	KOLKATA	
		DIAMOND POWER INFRASTRUCTURE LTD	VADODARA	
		GEMSCAB INDUSTRIES LTD	NEW DELHI	
		GOVIND CABLE INDUSTRIES	KOLKATA	
		GUPTA POWER INFRASTRUCTURE LIMITED	BHUBNESWAR	
		HAVELLS INDIA LIMITED	NOIDA	
		KEI INDUSTRIES LTD	NEW DELHI	
		KRISHNA ELECTRICAL INDUSTRIES LTD	GWALIOR	
		KEC INTERNATIONAL LIMITED	MUMBAI	

	TITLE	SPECIFICATION NO. PE-TS-497-501-A501
	2x660MW TALCHER TPP STAGE-III	REV 00
	DOUBLE GIRDER EOT CRANES ABOVE 100T SPECIFIC TECHNICAL REQUIREMENTS	Section IA Date DEC'22

SR. NO.	ITEM	SUPPLIERS	PLACE	REMARKS
		MANSFIELD CABLES COMPANY LTD	NOIDA	
		PARAMOUNT COMMUNICATIONS LTD	NEW DELHI	
		POLYCAB WIRES PVT. LTD	MUMBAI	
		RAVIN CABLES LIMITED	MUMBAI	
		SUYOG ELECTRICALS LTD	VADODARA	
		SPECIAL CABLES PVT. LTD	NEW DELHI	
		SCOT INNOVATION WIRES AND CABLES PVT. LTD	SOLAN	
		SRIRAM CABLES PVT. LTD	NEW DELHI	
		TORRENT CABLES LTD	AHMEDABAD	
		THERMO CABLES LTD	HYDERABAD	
		TIRUPATI PLASTOMATICS PVT. LTD	JAIPUR	
23.	XLPE CONTROL CABLES	APAR INDUSTRIES LTD	MUMBAI	
		CABLE CORPORATION OF INDIA LTD	MUMBAI	
		CRYSTAL CABLE INDUSTRIES LTD	KOLKATA	
		DIAMOND POWER INFRASTRUCTURE LTD	VADODARA	
		GEMSCAB INDUSTRIES LTD	NEW DELHI	
		HAVELLS INDIA LIMITED	NOIDA	
		KEI INDUSTRIES LTD	NEW DELHI	
		KRISHNA ELECTRICAL INDUSTRIES LTD	GWALIOR	
		KEC INTERNATIONAL LIMITED	MUMBAI	
		PARAMOUNT COMMUNICATIONS LTD	NEW DELHI	
		POLYCAB WIRES PVT. LTD	MUMBAI	
		RADIANT CORPORATION PRIVATE LIMITED	HYDERABAD	
		RAVIN CABLES LIMITED	MUMBAI	
		SUYOG ELECTRICALS LTD	VADODARA	
		SRIRAM CABLES PVT. LTD	NEW DELHI	
		TORRENT CABLES LTD	AHMEDABAD	
		UNIVERSAL CABLES LTD	SATNA	
24.	CABLE GLAND	COMMET		
		SUNIL&CO		
		ARUP ENGINEERING		
		JAINSON		
		DOWELL		
25.	PUSH BUTTONS	SIEMENS		
		L&T		
		BCH		
		SCHNEIDER		

	TITLE	SPECIFICATION NO. PE-TS-497-501-A501
	2x660MW TALCHER TPP STAGE-III	REV 00
	DOUBLE GIRDER EOT CRANES ABOVE 100T SPECIFIC TECHNICAL REQUIREMENTS	Section IA Date DEC'22

SR. NO.	ITEM	SUPPLIERS	PLACE	REMARKS
26.	LIMIT SWITCHES	SPEED-O-CONTROL ELECTROMAG		
27.	MASTER CONTROLLER	SPEED-O-CONTROL ELECTROMAG		
28.	SAFETY SWITCHES	ALSTOM		
		L&T		
		SIEMENS		
29.	PENDENT PUSH BUTTON STATION	OEM		
30.	INDICATING LAMPS	TECKNIC		
		BCH		
		SIEMENS		
		STANDARD		
31.	MCB	MDS		
		INDO COPP		
		STANDARD		
		SIEMENS		
		L&T		
		ABB SCHNEIDER		
32.	PANELS	OEM		
		RITTAL		
		PYROTECH		
33.	RESISTANCE BOXES	ENAPROS		
		OEM		
34.	FIRE EXTINGUISHERS	ASKA EQUIPMENTS LTD.		
		ASHOKA ENGINEERING COMPANY		
		KANADIA FYR FYTER PVT. LTD		
		NITIN FIRE PROTECTION INDUSTRIES LTD		
		NEW ENGINEERING CORPORATION		
		SAFEX FIRE SERVICES LTD		
		UNITED FIRE EQUIPMENTS PVT. LTD		
		ZENITH FIRE SERVICES (INDIA) PVT LTD		
35.	VVVF	YASKAWA		
		ABB		
		SIEMENS		
		SCHNIEDER		
		FUJI ELECTRIC		
		MITSUBISHI ELECTRIC		

1236331/2023/PS-PEM-MAX

	TITLE	SPECIFICATION NO. PE-TS-497-501-A501
	2x660MW TALCHER TPP STAGE-III	REV 00
	DOUBLE GIRDER EOT CRANES ABOVE 100T SPECIFIC TECHNICAL REQUIREMENTS	Section IA Date DEC'22

SR. NO.	ITEM	SUPPLIERS	PLACE	REMARKS
36.	SHROUDED DSL	SUSHEEL		
		STROMAG		
37.	ANTI COLLISION DEVICE	ELECTRONIC SWITCHES INDIA		
38.	LOAD CELL	IPA		
		SARTORIUS		
39.	RRC	ACROPOLIS ENGINEERING	-	
		SNT CONTROLS	-	
40.	GEAR BOX	OEM		* = Applicable for Geared Motors only
		ELECON ENGINEERS		
		SHANTI GEARS		
		PBL*		
		NAW*		
		NORD*		
		SEW*		
BONGFILIOLI*				
41.	RAIL	JSPL		
		SAIL		
42.	CENTRALIZED LUBRICATION / HYDRAULIC POWER PACK	LUBCON, PUNE PRAKASH LUBRICANT, KOLKATA AFMC, KOLKATA SKF ENGG AND LUBRICATION (LINCOLN HELIOS) VIJAY ENGINEERS INDO HYDRAULIC BOMBAY PVT LTD MEHATA HYDRAULIC EQUIPMENT CLAYSYS VEDNAT ENGINEERING SERVICES ELECTROPNEUMATICS AND HYDRAULIC PVT LTD SN HYDRAULIC		CRANE OEM MAKE POWERPACK IS NOT ALLOWED.

NOTE:

1. THE SUB VENDOR LIST ABOVE IS INDICATIVE ONLY AND IS SUBJECT TO BHEL AND NTPC APPROVAL DURING DETAILED ENGINEERING STAGE WITHOUT ANY COMMERCIAL & DELIVERY IMPLICATION TO BHEL
2. BIDDER TO PROPOSE SUB VENDOR WITHIN 4 WEEKS OF PLACEMENT OF LOI. THEREAFTER NO REQUEST FOR ADDITIONAL SUB-VENDOR SHALL BE ENTERTAINED.
3. THE INSPECTION CATEGORY WILL BE INTIMATED AFTER AWARD OF CONTRACT BY BHEL/CUSTOMER. HOWEVER THE SAME WILL BE ADHERED BY THE BIDDER WITHOUT ANY COMMERCIAL AND DELIVERY IMPLICATION TO BHEL/ NTPC.



TITLE

2x660MW TALCHER TPP STAGE-III

DOUBLE GIRDER EOT CRANES ABOVE 100T
SPECIFIC TECHNICAL REQUIREMENTS

SPECIFICATION NO. PE-TS-497-501-A501

REV 00

Section IA

Date DEC'22

ANNEXURE-II MANDATORY SPARES

MANDATORY SPARES:

S. NO.	ITEM DESCRIPTION	QUANTITY
1	EOT CRANES-Main TG Hall	
1.1	Mechanical: Main TG Hall	
(a)	Bearings for long travel wheels	1 Set (Requirement for one Crane)
(b)	Bearings for cross travel wheels	1 Set (Requirement for one Crane)
(c)	Bearings for Gear Boxes for each type of Hoist & travel (Main and aux hoist (if applicable), LT and CT travel))	1 Set (Requirement for one Crane)
(d)	Brake Liner for all the brakes (main and aux hoist, LT and CT travel))	2 Sets (Requirement for two Crane)
(e)	Hydraulic thruster for all Brakes (Main and aux hoist, CT and LT travel)	1 Set (Requirement for one Crane)
(f)	Oil Seals (both main and aux hoist, CT and LT)	2 Sets (Requirement for two Crane)
(g)	Brake springs for all brakes (both main and aux hoist, LT and CT travel)	1 Set (Requirement for one Crane)
(h)	Wire Rope for Aux. Hook	1 No
(i)	Wire Rope for Main Hook	1 No
1.2	Electrical:	
i)	Solenoid Coils for Brakes	2 sets
ii)	MCBs/MCCBS/Fuse links for the whole crane	1 set
iii)	Contactors and overload Relays for Motors of the EOT	1 set of each type, size & rating
iv)	Timers of each type, size & rating	1 set
v)	Limit Switches for	
a	Main Hoist	1 set
b	Aux. Hoist	1 set
c	Cross Travel	1 set
d	Long Travel	1 set
vi)	Master Controller for Aux. Hoist	1 set each
vii)	Drive for MH, AH, CT<	1 no. of each type& rating

Notes:-

- One (1) Set is defined as 100% requirement for one crane for the entire cranes of similar size & capacity.
- All essential spares shall be supplied as per the requirement of the specifications. In case any spare indicated in the specification is not applicable for particular equipment then suitable applicable alternate spare have been offered / shall be supplied without any financial implication.
- Unless stated otherwise a 'Set', it will include the total requirement of the item for a unit module or the station as specified. Also, set for the particular equipment e.g. 'set' of bearings for a pump would include the total number of bearings in a pump. Also the 'set' would include all components required to replace the item; for example a set of bearing shall include all hardware normally required while replacing the bearings. It is further, intended that the assembly/sub-assembly which have different orientation (like left hand or right hand, top or bottom), different direction of rotation or mirror image positioning or any other reasons which result in maintaining two different sets of the spares to be

	TITLE	SPECIFICATION NO. PE-TS-497-501-A501	
	2x660MW TALCHER TPP STAGE-III	REV 00	
	DOUBLE GIRDER EOT CRANES ABOVE 100T	Section IA	Date DEC'22
	SPECIFIC TECHNICAL REQUIREMENTS		

used for the subject assembly/sub-assembly, these shall be considered as different types of assembly/sub-assembly.

4. Wherever the quantities have been indicated for each type, size, thickness, material, radius, range etc. these shall cover all the items supplied and installed.

5. In case spares indicated in the list are not applicable to the particular design offered by the bidder, the bidder should offer spares applicable to offered design with quantities generally in line with the approach followed in the above list.

6. Any item which is quoted as "not applicable" in the above list and is found to be "applicable" at a later date shall be supplied by the Bidder without any commercial implications. The Bidder shall note that if there is any change/ variation in equipment/ system during detail engineering which causes any change/ variation in the essential spares quantity, the same shall be supplied without any commercial implications. The price indicated for the mandatory spares shall be considered for the purpose of evaluation.

7. Mandatory spares shall not be dispatched before dispatch of corresponding main equipment. The spares shall be treated and packed for a long storage under the climatic condition prevailing at site.

8. Interchangeability and Packings: All spares supplied under this contract shall be strictly interchangeable with parts for which they are intended for replacements. These spares should include all mounted accessories like components, boards, add on items, fitting, connectors etc. and be complete in all respects so that the replacement of the main items by these spares does not require any additional item. The vendors must conform the pair to pair compatibility of each electrical spares modules with the modules should be supplied in the original package. All electronic modules should be pre set and/or preprogrammed for ready use at site. Alternatively, suitable instruction sheet indicating the details of required PCB jumper position, BCD which is setting, EPROM/PROM listing etc should be packed along with each module. Also a caution mark sign should be put on all such module which needs pre setting/pre programming before putting them in to service. The spare shall be treated and properly packed for long term storage.

9. Identification: Each spare shall be clearly marked and labeled on the outside of the packing with its description. When more than one spare part is packed in single case, a general description of the contents shall be shown on the outside of such case and a detailed list enclosed. All cases, containers and other packages must be suitably marked and numbered for the purpose of identification.

10. Mandatory spares listed above is bare minimum requirement. In case any additional mandatory spares requirement is covered elsewhere in the tender specification, same shall be deemed to have been covered in bidders scope of supply.

	TITLE	SPECIFICATION NO. PE-TS-497-501-A501	
	2x660MW TALCHER TPP STAGE-III	REV 00	
	DOUBLE GIRDER EOT CRANES ABOVE 100T	Section IA	Date DEC'22
	SPECIFIC TECHNICAL REQUIREMENTS		

ANNEXURE III - TOOLS & TACKLES

A complete unused new set of special purpose tools, tackles and accessories along with detailed instructions and maintenance manual for the crane shall be supplied. Each tool and wrench shall be stamped so as to be identified, easy for its use. The tools shall be supplied in steel toolbox and with a copy of instruction manual. The items supplied shall be of the best quality and minimum the following shall be provided.

S-No.	Description	Qty.
1	Complete set of ring spanners (Indicate the sizes offered)	1 Set
2	Complete set of screwdrivers (Min. 6 Nos., Indicate the sizes)	1 Set
3.	Adjustable Spanner	1 No.
4.	Insulated plier	1 No.
5	Wrench spanner	1 No.
6.	Grease Gun	1 No.
7.	Oil Gun.	1 No.
8.	Hand Lamp.	1 No.
9	Line tester	1 No.

Note: - One set of tool and tackles with O&M manual in the toolbox shall be supplied. Further in addition to above mentioned items, if any other items is required for maintenance of cranes, the same shall also be included as a part of maintenance tools by the bidder.



TITLE

2x660MW TALCHER TPP STAGE-III

DOUBLE GIRDER EOT CRANES ABOVE 100T
SPECIFIC TECHNICAL REQUIREMENTS

SPECIFICATION NO. PE-TS-497-501-A501

REV 00

Section IA

Date DEC'22

ANNEXURE IV PAINTING SPECIFICATION

1. Painting specification for steel structures:-

Surface preparation: De greasing and Mechanical cleaning with wire brush or blasting according to SIS 055900, Grade 2 ½ .

Primer : Epoxy based Zinc Phosphate. - 1 coat, DFT 35 µm per coat.

Intermediate : Epoxy base Tio2 pigmented coat - 1 coat, DFT 35 µm per coat

Finish Coat : Epoxy base paint - 2 coats, DFT 25 µm per coat. Final coat of paint Aliphatic Acrylic Polyurethane CDE134, %V=40.0(min.) – 1 coat 30 µm.

Total DFT : 150µ

2. Painting specification for Indoor components such as motors, electrical parts etc:-

Epoxy based with suitable additives. The thickness of finish coat shall be minimum 50 microns (minimum total DFT shall be 100 microns). However in case electrostatic process of painting is offered for any electrical equipment, minimum paint thickness of 50 microns shall be acceptable for finish coat.

3. Color Shade:

SL. No	Item Description	Color Shade	Remarks
1	Crane Structure	Golden Yellow shade 356 as per IS-5	Colour band-Black
2	Trolley and hook	Golden Yellow shade 356 as per IS-5	
3	Motors	Light Gray shade 631 as per IS-5	
4	Control Panels	Light Gray (Powder coated) as per IS-5	



TITLE

2x660MW TALCHER TPP STAGE-III

DOUBLE GIRDER EOT CRANES ABOVE 100T
SPECIFIC TECHNICAL REQUIREMENTS

SPECIFICATION NO. PE-TS-497-501-A501

REV 00

Section IA

Date DEC'22

ANNEXURE-V

DRAWINGS/ DOCUMENTS TO BE SUBMITTED AFTER AWARD OF CONTRACT

The successful bidder shall submit the following drawings / documents during detail engineering for customer's approval /information:

S.N	BHEL drawing No.	Title	Approval category	Schedule date of submission from date of LOI.
1	PE-V0-497-501-A501	Manufacturing Quality Plan with sub vendor list For TG Hall Crane	A	2
2	PE-V0-497-501-A503	Data sheet of motors for TG Hall Crane	I	5
3	PE-V0-497-501-A504	Mechanism Sizing Calculation Including storm brake calculation for TG Hall Crane	A	2
4	PE-V0-497-501-A505	General arrangement for TG Hall Crane with CT DSL details	A	2
5	PE-V0-497-501-A506	Crab sub assembly for TG Hall crane with CT wheel assembly	I	3
6	PE-V0-497-501-A508	General arrangement for PVC shrouded DSL for TG Hall crane	I	3
7	PE-V0-497-501-A509	Main and Auxiliary hook block assembly with details of hook, nut and check plate For TG Hall Crane	I	2
8	PE-V0-497-501-A510	Long travel Machinery Assembly with LT wheel assembly For TG Hall Crane	I	4
9	PE-V0-497-501-A511	Lifting beam assembly for TG Hall Crane	A	3
10	PE-V0-497-501-A512	Structural calculations For TG Hall Crane	A	3
11	PE-V0-497-501-A514	O & M Manual For TG Hall Crane	I	9
12	PE-V0-497-501-A515	Detailed BOM/BOQ for TG Hall Crane	I	8
13	PE-V0-497-501-A516	Electrical equipment layout in cabin for TG Hall crane	I	5
14	PE-V0-497-501-A517	"Schematic circuit diagram of a) Protective panel, Main and lighting circuit & BOM b) Main hoist panel & BOM c) Aux. hoist panel & BOM d) Cross Traverse & BOM e) Long Traverse & BOM Including earthing diagram For TG Hall Crane"	A	5
15	PE-V0-497-501-A518	"General Arrangement of a) Protective panel b) Main hoist panel c) Aux. hoist panel d) Cross Travel panel e) Long Traverse travel panel. f) Pendent g) Remote Radio Control For TG Hall Crane"	I	5



TITLE

2x660MW TALCHER TPP STAGE-III

DOUBLE GIRDER EOT CRANES ABOVE 100T
SPECIFIC TECHNICAL REQUIREMENTS

SPECIFICATION NO. PE-TS-497-501-A501

REV 00

Section IA

Date DEC'22

16	PE-V0-497-501-A519	Cable Sizing and cable schedule For TG Hall Crane	A	6
17	PE-V0-497-501-A520	Crane Operational write up For TG Hall Crane	I	5
18	PE-V0-497-501-A521	Type test certificate (for motors) For TG Hall Crane	A	8
19	PE-V0-497-501-A523	Mandatory spare parts list For TG Hall Crane	A	8
20	PE-V0-497-501-A525	Erection procedure For TG Hall Crane	I	8
21	PE-V0-497-501-A526	Manufacturing Quality Plan For Lifting Beam	A	3
22	PE-V0-497-501-A527	Data sheet of TG Hall Crane with painting details	A	3
23	PE-V0-497-501-A530	Electrical load for TG Hall EOT Crane	I	8
24	PE-V0-497-501-A532	Gantry Rail installation for TG Hall crane	I	3
25	PE-V0-497-501-A550	Crane lubrication drawing For TG Hall Crane	I	6
LEGENDS				
A= Approval category				
I= Information category				

Notes:

- The above drawing list is tentative and shall be finalized with the successful bidder after placement of order. While some of the drawings indicated above may not be applicable, some additional drawings may also be required based on scope of work.
- Drawings shall be prepared in Auto-Cad latest edition. Required no. of hard and soft copies (editable) of the drawings shall be furnished as per requirement specified elsewhere in the specification.
- Only manual calculation with authentic supporting literature (e.g. extracts of hand Book/ standard/codes) shall be acceptable. All design calculations and drawings shall be in SI system only.
- Bidder to note that all values/dimensions/elevations etc. without supporting back up data adopted/assumed by the successful bidder (during contract stage) in the design calculation/drawings shall be taken by the customer/owner to be correct unless they are stipulated in the specification. Any problem arising later in this regard shall be made good by the successful bidder at his cost and no extension of time shall be granted for the same.
- All the drawings and documents including general arrangement drawing, data sheet, calculation etc. to be furnished to the customer during detailed engineering stage shall include / indicate the following details for clarity w.r.t. Inspection, construction, erection and maintenance etc.:-
 - All drawings and documents shall indicate the list of all reference drawings including general arrangement.
 - All drawings shall include / show plan, elevation, side view, cross - section, skin section, blow - up view; all major self-manufactured and bought out items shall be labeled and included in BOQ / BOM in tabular form.
 - Painting schedule shall also be made as a part of general arrangement drawing of each equipment / items indicating at least 3 trade names.
 - All the drawings required to be furnished to customer during detailed engineering stage shall include technical parameters, details of paints and lubrication, hardness and BOQ / BOM in tabular form indicating all major components including bought

	TITLE	SPECIFICATION NO. PE-TS-497-501-A501	
	2x660MW TALCHER TPP STAGE-III	REV 00	
	DOUBLE GIRDER EOT CRANES ABOVE 100T	Section IA	Date DEC'22
	SPECIFIC TECHNICAL REQUIREMENTS		

out items and their quantity, material of construction indicating its applicable code / standard, weight, make etc.

- e) Drawings/ documents to be submitted for purchasers review/ approval shall be under Revision A, B, C... etc. while drawings /documents to be submitted thereafter for customer's approval after purchaser's approval shall be under R-0, 1, 2, 3etc.
- f) Drawings and documents not covered above but required to check safety of machines/ system, shall be submitted during detailed engineering stage without any commercial implication.
- g) All drawings shall include "B.O.M" and indicate quantity, material of construction, make along with IS/BS No., Technical parameters, dimensions, hardness, machining symbol and tolerance, requirement of radiography and hydraulic tests, painting details, elevation, side view, plan, skin section and blow-up view for clarity.
- h) All drawings shall be prepared as per BHEL's title block and shall bear BHEL's drawing No.
- i) Schedule of drawings submissions, comment incorporations & approval shall be as stipulated in the specifications. The successful bidder shall depute his design personnel to BHEL's/ Customer's/ Consultant's office for across the table resolution of issues and to get documents approved in the stipulated time.
- j) Bidder to follow the following the drawing submission schedule:
 - i. 1st submission of drawings from date of LOI as per the submission schedule.
 - ii. Every revised submission incorporating comments – within 7 days.
- k) Bidder to submit revised drawings complete in all respects incorporating all comments. Any incomplete drawing submitted shall be treated as non-submission with delays attributable to bidder's account. For any clarification/ discussion required to complete the drawings, the bidder shall himself depute his personal to BHEL for across the table discussions/ finalizations/ submissions of drawings.

	TITLE	SPECIFICATION NO. PE-TS-497-501-A501	
	2x660MW TALCHER TPP STAGE-III	REV 00	
	DOUBLE GIRDER EOT CRANES ABOVE 100T	Section IA	Date DEC'22
	SPECIFIC TECHNICAL REQUIREMENTS		

ANNEXURE VI – PACKING PROCEDURE

Packing and Marking

All the equipment shall be suitably protected, coated, covered or boxed and crated to prevent damage or deterioration during transit, handling and storage at site till the time of erection. The Contractor shall be responsible for all loss or damage during transportation, handling and storage due to improper packing.

The identification marking indicating the name and address of the consignee shall be clearly marked in indelible ink on two opposite sides and top of each of the packages. In addition the Contractor shall include in the marking gross and net weight, outer dimension and cubic measurement.

Each package shall be accompanied by a packing note (in weather proof paper) quoting specifically the name of the Contractor, the number and date of contract and names of the office placing the contract, nomenclature of contents and Bill of Material.

	TITLE	SPECIFICATION NO. PE-TS-497-501-A501	
	2x660MW TALCHER TPP STAGE-III	REV 00	
	DOUBLE GIRDER EOT CRANES ABOVE 100T	Section IA	Date DEC'22
	SPECIFIC TECHNICAL REQUIREMENTS		

ANNEXURE-VII

Procedure for Load & Overload testing of Double Girder EOT Cranes at Manufacturer's Works

Objective: To demonstrate final NO load, Load, Overload, Deflection & Functional tests of assembled crane/s for the purpose of acceptance.

Basic Assumptions / Inputs for testing at Works:

- Actual job hook shall be used for load & overload tests for hoisting.
- Actual ropes shall be used for load & overload testing.
- Shop cables can be used for temporary connection for the purpose of showing various functional tests at shop.
- Interlock and limit switch operation check will be shown with load for hoisting and CT motion.

Procedure for Load / Overload testing:

The cranes shall be tested for no load, load test & overload test at works generally in conformance with the IS – 3177 (latest edition). Specifically with respect to the load / overload testing of crane, the following tests as per the outlined procedures shall be done at works.

- Deflection of the girder will be measured at SWL when the trolley with load is at the middle of the girder.
- No load and full load current of the motors will be measured to verify whether it is as per the approved data sheet of the motor. Resistors in the circuit will be checked for any overheating of the element.
- Overload relays will be checked for proper functioning.

Hoisting & Cross Travel motions:

The load will be gradually raised to 125 percent of the rated capacity (SWL) with actual hook. The load will be lifted upward to about 1 meter height above its support and stop again. Check for any undue drift in the load. If load drifts, check the adjustment of brakes and repeat the above procedure. Then lower the load to rest on support/ground.

	TITLE	SPECIFICATION NO. PE-TS-497-501-A501	
	2x660MW TALCHER TPP STAGE-III	REV 00	
	DOUBLE GIRDER EOT CRANES ABOVE 100T	Section IA	Date DEC'22
	SPECIFIC TECHNICAL REQUIREMENTS		

For checking the cross travel, raise the load up to one (1) meter height above supports and then move the trolley with load about one (1) meter in either direction of the bridge. Then lower the load to rest on support/ ground.

Creep speed motions shall be checked over a distance of about 500 mm.

Note: Complete No load, load & over load tests in line with IS-3177 (latest edition) shall also be done after erection of EOT crane at site.



TITLE

2x660MW TALCHER TPP STAGE-III

SPECIFICATION NO. PE-TS-497-501-A501

REV 00

DOUBLE GIRDER EOT CRANES ABOVE 100T
SPECIFIC TECHNICAL REQUIREMENTS

Section IA

Date DEC'22

ANNEXURE-VIII**Format for Operation & Maintenance Manual**

Project name :

Project number :

Package Name :

PO reference :

Document number :

Revision number :

Sl.no. & Sections	Description	Tick (√) if included in Manual			Remarks
		Yes	No	Not Applicable	
1.	Cover page				
1.1	Project Name				
1.2	Customer/consultant Name				
1.3	Name of Package				
1.4	Supplier details with phone, FAX ,email address , Emergency Contact number				
1.5	Name and sign of prepared by , checked by & approved by				
1.6	Revision history with approval Details				
2.0	Index				
2.1	showing the sections & related page nos All the pages should be numbered section wise				
3.0	Description of Plant/System				
3.1	Description /write up of operating principle of system equipment/ associated sub-systems & accessories/controls system , operating conditions, performance parameters under normal , start up and special cases				
3.2	Equipment list and basic parameter with Tag numbers				
3.3	Data sheets approved by Customer/for information and catalogues provided by original manufacturer				
3.4	Associated other packages and Interface /terminal points				
3.5	P&ID & Process Diagrams				
3.6	GA Layout drawings, As-built drawings , Actual photograph of items/system (Drawings of A2 & bigger sizes are to be attached in the last)				
3.7	Single line/wiring diagrams				
3.8	Control philosophy /control write-ups				
4.0	Commissioning Activities (if not covered				



TITLE

2x660MW TALCHER TPP STAGE-III

DOUBLE GIRDER EOT CRANES ABOVE 100T
SPECIFIC TECHNICAL REQUIREMENTS

SPECIFICATION NO. PE-TS-497-501-A501

REV 00

Section IA

Date DEC'22

	in separate document i.e. erection manual, commissioning manual)				
4.1	Pre-Commissioning Checks				
4.2	handling of items at site				
4.3	Storage at site				
4.4	Unpacking & Installation procedure				
5.0	Operation Guidelines for plant personal/user/operator				
5.1	Interlock & Protection logic along with the limiting values of protection settings for the equipment along with brief philosophy behind the logic, drawings etc. to be provided.				
5.2	Start up, normal operation and shut down procedure for equipments along with the associated systems in step by step mode. Valve sequence chart, step list, interlocks etc. with Equipment isolating procedures to be mentioned.				
5.3	Do's & Don't of the equipments.				
5.4	Safety precautions to be taken during normal operation. Safety symbols, Emergency instructions on total power failure condition/lubrication failure/any other condition				
5.5	Parameters to be monitored with normal values and limiting values				
5.6	Trouble shooting with causes and remedial measures				
5.7	Routine operational checks, recommended logs & records				
5.8	Changeover schedule if more than one auxiliary for the same purpose is given				
5.9	Painting requirement and schedule				
5.10	Inspection, repair , Testing and calibration procedures				
6.0	Maintenance guidelines for plant personal				
6.1	List of Special Tools and Tackles required for Overhaul/Trouble shooting including special testing equipment required for calibration etc.				
6.2	Stepwise dismantling and re-assembly procedure clearly specifying the tools to be used, checks to be made, records to be maintained, clearances etc. to be mentioned. Tolerances for fitment of various components to be given.				
6.3	Preventive Maintenance & Overhauling schedules linked with running hours/calendar period along with checks to be given				



TITLE

2x660MW TALCHER TPP STAGE-III

**DOUBLE GIRDER EOT CRANES ABOVE 100T
SPECIFIC TECHNICAL REQUIREMENTS**

SPECIFICATION NO. PE-TS-497-501-A501

REV 00

Section IA

Date DEC'22

6.4	Long term maintenance schedules especially for structural, foundations etc.				
6.5	Consumable list along with the estimated quantity required during commissioning, normal running and during maintenance like Preventive Maintenances and Overhaul. Storage/handling requirement of consumables/self-life.				
6.6	List of lubricants with their Indian equivalent, Lubrication Schedule, Quantity required for each equipment for complete replacement is to be given				
6.7	List of vendors & Sub-vendors with their latest addresses, service centres ,Telephone Nos., Fax Nos., Mobile Nos., e-mail IDs etc.				
6.8	List of mandatory and recommended spare parts list				
6.9	Tentative Lead time required for ordering of spares from the equipment supplier				
6.10	Guarantee and warranty clauses				
7.0	Statutory and other specific requirements considerations.				
8.0	List of reference documents				
9.0	Binding as per requirement				

CLAUSE NO.	GENERAL TECHNICAL REQUIREMENTS			
<p>8.03.05</p> <p>8.03.05.01</p> <p>8.03.05.02</p> <p>8.03.05.03</p>	<p>e-Learning Package:</p> <p>e-learning packages shall be supplied for the equipment / system for the following Steam Turbine Generator & auxiliaries and Steam Generator & auxiliaries along with associated electrical and C&I system.</p> <p>Steam Turbine Generator & Auxiliaries</p> <p>Steam Turbine including stop valves, control valves, overload valves and cross over piping. Steam Turbine Auxiliary Systems including Quick Closing and Ordinary NRVs, Turbine gland sealing system, Lubricating oil system and its purification system, Centralized oil storage and its purification system, Control fluid and its purification system, governing and protection system, exhaust hood spray cooling system, drainage and vent system, turbine preservation system, HP/LP Bypass system.</p> <p>Generator and Auxiliary System including Generator, complete hydrogen cooling, carbon dioxide and nitrogen gas systems as applicable, complete seal oil system, complete water cooling system where applicable and complete excitation system.</p> <p>Condensing Plant including Condenser, Condenser air evacuation system and Condenser on load tube cleaning system as applicable etc.</p> <p>Drip Pump along with all accessories as applicable, Condensate Extraction Pumps along with all accessories, Deaerator level Control Station, Feed Water Heating Plant including Drain Cooler, low pressure heaters, deaerator and feed storage tank, high pressure heaters and associated accessories, Boiler Feed Pumps along with all accessories, Drive Turbine for Boiler Feed Pump along with all accessories, Feed regulating station, Make up system to Condenser, Gland Steam Condenser Recirculation System, Turbine Hall EOT Cranes and EOT Crane for Boiler Feed Pump as applicable.</p> <p>Steam Generator & Auxiliaries</p> <p>Furnace/evaporator, separator & drain collection vessel, superheater, reheater, economiser, startup recirculation & drain system, desuperheating spray system, safety valves, soot blowing system, draft plant including FD & ID fans, PA fan, air preheaters, SCAPH, coal preparation and firing system including raw coal feeder and pulverisers, coal burners, fuel oil system and oil burners, Electrostatic precipitator, NOx control system and Flue gas desulphurisation system, Aux. PRDS system.</p> <p>These packages shall be installed on the Learning Management Server (LMS) of Power Management Institute (PMI), NTPC located at Noida. The Engineer- In-Charge (EIC) for the e-learning modules shall be from PMI.</p> <p>1. The objective of the e-Learning package consisting of courses for erection, commissioning, operation and maintenance of equipment / system as specified</p>			
<p>TALCHER THERMAL POWER PROJECT STAGE-III (2X660 MW) EPC PACKAGE</p>	<p>TECHNICAL SPECIFICATIONS SECTION VI, PART-C BID DOC. NO.:CS-4540-001A-2</p>	<p>GENERAL TECHNICAL REQUIREMENTS</p>	<p>PAGE 19 OF 114</p>	

CLAUSE NO.	GENERAL TECHNICAL REQUIREMENTS			
	<p>above is to facilitate the employees to have first hand information / requirement with respect to above activities for the supplied equipment / system .</p> <p>2. The bidder shall submit e-learning courses each for erection, commissioning, operation and maintenance of each of the equipment / system supplied as above.</p> <p>a. The erection course(s) should include instructions on pre-checks, prerequisites, erection strategy, erection procedure etc.</p> <p>b. The commissioning course(s) should include instructions on pre-commissioning, commissioning, initial operation etc.</p> <p>c. The operation course(s) should include instructions on the permissive, interlocks, physical check-ups, start-up, shutdown and protections etc.</p> <p>d. The maintenance course(s) should include instructions on predictive, preventive, breakdown and overhauling.</p> <p>Depth of coverage of above courses shall be as specified for “Instruction Manuals” in above clauses. A literature on caution / safety while handling equipment / system for the above modules shall follow the description of the said equipment /system.</p> <p>3. The e-Learning packages on equipment / system shall be installed by the vendor and shall be successfully test run in the presence of EIC or representative before acceptance by NTPC. The vendor will also give the master copy in form of Flash Drive/CD/DVD. The respective module for erection & commissioning shall be delivered and successfully test run at least three months before the scheduled start of the corresponding activity at site.</p> <p>The respective module for operation & maintenance shall be delivered and successfully test run at least three months before scheduled first synchronization of first unit.</p> <p>4. e-Learning course broad requirements:</p> <p>a. The courses shall be web based and mobile based Application type. It shall run on all possible versions of web browser like Internet Explorer, Google Chrome, Firefox etc. on Laptop/Desktop and shall be Smartphone/Tablet/Mobile responsive. The Mobile responsive courses shall run on Android, Windows Mobile, Blackberry, iOS etc.</p> <p>b. The courses shall support liquid/fluid page layout so that the entire screen gets adjusted to PC, Laptop, Smartphone/Mobile, Tablet and any other display devices.</p> <p>c. Course content text shall be in English language and be associated with a voiceover in English language with Indian accent.</p>			
<p>TALCHER THERMAL POWER PROJECT STAGE-III (2X660 MW) EPC PACKAGE</p>	<p>TECHNICAL SPECIFICATIONS SECTION VI, PART-C BID DOC. NO.:CS-4540-001A-2</p>	<p>GENERAL TECHNICAL REQUIREMENTS</p>	<p>PAGE 20 OF 114</p>	

CLAUSE NO.	GENERAL TECHNICAL REQUIREMENTS			
	<p>d. Courses shall be SCORM (Sharable Content Object Reference Model) compliant, version 1.2 which is compatible with LMS at PMI.</p> <p>e. Each course shall have every physical and functional detail of the equipment / system supplied.</p> <p>f. Each of the e-Learning course shall be based on multiple web pages and mobile pages with multiple modules.</p> <p>g. There shall be option for self-assessment test after every course. In case the user doesn't opt for self-assessment test the user shall be able to go to the next course. There shall be no restriction in no. of times for repeating the assessments. All correct answers along with the answers marked by the users shall be displayed at the end of test/quiz.</p> <p>h. If Java and Flash, as applicable are not available in the system to run the package, then there shall be a prompt message for updation of the same.</p> <p>i. Each course shall have a self-running interactive content with navigation buttons containing forward, backward, pause, bookmark and menu options in the course window.</p> <p>j. The course shall contain chapter titled 'Introduction/overview' that explains the purpose of the course.</p> <p>k. The course content shall contain descriptive text shall be factual, specific, terse, clearly worded, and simply illustrative, so that the user can understand it.</p> <p>l. The system shall provide the user with the ability to select the information with a Cursor.</p> <p>m. The course menu should contain table of content linked to concerned pages. The user shall be given the capability to access all of the functions available on the system through a menu system. This shall consist of active buttons, which shall control a hierarchy of pull down/pop-up menus. Menu shall appear quickly and exist only while a selection is being made. The user shall be given the capability to position the cursor or pointer on the menu item and use pointer device such as mouse to activate the function.</p> <p>n. Every course shall contain the 3D design/drawing/exploded view/360° turn around view of the equipment/system, textual description of the equipment/system and its functionality with video (as applicable), animation and audio.</p> <p>o. The users shall be able to control audio sound level associated with the courses.</p> <p>p. Drawings / text in the courses shall be scalable (Zoom In/ Out).</p> <p>q. The user shall have the capability to record a bookmark to mark displayed information for later recall, whenever he accesses the same course next time.</p>			
<p>TALCHER THERMAL POWER PROJECT STAGE-III (2X660 MW) EPC PACKAGE</p>	<p>TECHNICAL SPECIFICATIONS SECTION VI, PART-C BID DOC. NO.:CS-4540-001A-2</p>	<p>GENERAL TECHNICAL REQUIREMENTS</p>	<p>PAGE 21 OF 114</p>	

CLAUSE NO.	GENERAL TECHNICAL REQUIREMENTS			
	<p>Notes:</p> <ol style="list-style-type: none"> 1. e-learning Package of an equipment / system shall include e-learning courses for each of erection, commissioning, operation and maintenance of that equipment / system. 2. e-learning courses on erection, commissioning, operation and maintenance of an equipment / system shall include e-learning lessons/chapters/modules (as required) for erection, commissioning, operation and maintenance respectively of that equipment / system. 3. The vendor shall get the approval of one sample course from EIC before proceeding for further courses. <p>8.04.00 Provision for Fail Safe operation of vital Equipments</p> <p>All the Plant and equipments / Systems supplied under the contract shall be designed following "Fail Safe" concept. In case of failure of Power supply like Electric power, Hydraulic pressure, Pneumatic pressure, Vacuum etc. the system should be designed in such a way that the equipment/Valves/dampers etc. shall always move/remains (as applicable) to safest position as per system requirement to ensure safety of Man and Machinery.</p> <p>8.05.00 Engineering Co-ordination Procedure</p> <p>8.05.01 The following principal coordinators will be identified by respective organizations at time of award of contract:</p> <p>NTPC Engineering Coordinator (NTPC EC):</p> <p>Name : _____</p> <p>Designation : _____</p> <p>Address : _____</p> <p>a) Postal : _____</p> <p>b) Telegraphic / e-Mail : _____</p> <p>c) FAX : _____ TELEPHONE : _____</p> <p>Contractor's/ Vendor's Engineering Coordinator (VENDOR EC):</p> <p>Name : _____</p> <p>Designation : _____</p>			
<p>TALCHER THERMAL POWER PROJECT STAGE-III (2X660 MW) EPC PACKAGE</p>	<p>TECHNICAL SPECIFICATIONS SECTION VI, PART-C BID DOC. NO.:CS-4540-001A-2</p>	<p>GENERAL TECHNICAL REQUIREMENTS</p>	<p>PAGE 22 OF 114</p>	



TITLE
2x660MW TALCHER TPP STAGE-III
DOUBLE GIRDER EOT CRANES ABOVE 100T
SPECIFIC TECHNICAL REQUIREMENTS

SPECIFICATION NO. PE-TS-497-501-A501
REV 00
Section IA Date DEC'22
Page 1 of 2

SECTION – IA
CRANE CLEARANCE DIAGRAM

1236331/2023/PS-PEM-MAX



TITLE

2x660MW TALCHER TPP STAGE-III

DOUBLE GIRDER EOT CRANES ABOVE 100T

SPECIFIC TECHNICAL REQUIREMENTS

SPECIFICATION NO. PE-TS-497-501-A501

REV 00

Section

IA

Date DEC'22

SECTION – IA

STANDARD QUALITY PLAN

		MANUFACTURER'S NAME & ADDRESS		STANDARD MANUFACTURING QUALITY PLAN				PROJECT: 2X660 MW TALCHER TPP					
				ITEM:		QP NO :		PACKAGE : DOUBLE GIRDER CRANES					
						REV : 0		CONTRACT NO :					
						DATE :		CONTRACTOR :					
								VENDOR'S QAP No :					
SL. NO.	COMPONENTS & OPERATION	CHARACTERISTICS	CLASS	TYPE OF CHECK	QUANTUM OF CHECK	REFERENCE DOCUMENT	ACCEPTANCE NORMS	FORMAT OF RECORDS	AGENCY			REMARKS	
	4	3	4	5	6	7	8	9	D*	**	10	11	
1	Fabricated components Box Girder, End Carriage, Crab Frame, Rope Drum												
a	Material	Chemical & Physical Properties	Major	Corelation with T.C./ Check test in absence of T.C.	1/Heat/Batch	E250 Grade BR IS: 2062	E250 Grade BR IS: 2062	Mfr's T.C/ Check Test Report	√	P	V	V	Refer note: 1
		U.T of plates.		Ultrasonic	100%	ASTM A435	ASTM A435	T.C. / I.R.	√	P	V	V	U.T. ON ABOVE 20MM THICK PLATE
b	weld setup	dimensions	Major	Measurement	100%	Components drawings	Components drawings	Vendor's inspection report		P			
1A	Seamless pipe for rope drum	Chemical & Physical Properties	major	Corelation with T.C./ Check test in absence of T.C.	100%	ASTM A106Gr B	ASTM A106Gr B	Mfr's T.C/ Check Test Report	√	P	V	V	Refer note: 1
		NDT	Major	Macro etching & flattening	100%	ASTM A106Gr B	ASTM A106Gr B	MTC/Lab TC	√	P	V	V	
		NDT	Major	UT	100%	ASTM E-213-2007	Notch depth shall not be more than 12.5% of thickness of pipe	UT Report	√	P	V	V	
2	Welding WPS (Welding procedure specification) in line with ASME sec. IX (QW - 482) - For Box Girder, End Carriage, Crab Frame, Trolley Gear Box Casing & Rope Drum												
a	Check for welding procedure qulification, welder's performance	Welding parameters	Major	Review of documents	100%	ASME Sec-IX	ASME Sec-IX	QW-482,QW-483, QW-484 as per ASME Sec-IX	√	P	V	V	WPS/PQR/WPQ approved/ reviewed by NTPC/ NPCIL/ BVI/ LLOYES/TUV etc. shall be acceptable
b	Back chipping	surface defect	Major	DPT	100%	ASME Sec-VIII, Div-I, Appen - 8	ASME Sec-VIII, Div-I, Appen - 8	DP Report	√	P	V	V	
c	Butt Welds	NDT	Critical	RT	100% in tension, 25% in compression, 100% in rope drum	ASME Sec-V	ASME Sec-VIII, CI UW-51 & 52	RT Report	√	P	V	V	

		MANUFACTURER'S NAME & ADDRESS		STANDARD MANUFACTURING QUALITY PLAN				PROJECT: 2X660 MW TALCHER TPP					
				ITEM:		QP NO :		PACKAGE : DOUBLE GIRDER CRANES					
						REV : 0		CONTRACT NO :					
						DATE :		CONTRACTOR :					
								VENDOR'S QAP No :					
SL. NO.	COMPONENTS & OPERATION	CHARACTERISTICS	CLASS	TYPE PF CHECK	QUANTUM OF CHECK	REFERENCE DOCUMENT	ACCEPTANCE NORMS	FORMAT OF RECORDS	D*	M**	C	N	REMARKS
1	4	3	4	5	6	7	8	9					11
			Critical	DPT	100%	ASME Sec-V	ASME Sec-VIII, Div-I, Appen - 8	DP Report	√	P	W	V	DP test of fillet weld for rope drum to be conducted. After final machining random witness by BHEL
d	fillet welds	Size and surface defects	Major	Visual	100%	Manufacturing drawing	Manufacturing drawing	Vender inspection Report	√	P	V	V	
		NDT	Major	DPT	10% RANDOM	ASME Sec-V	ASME Sec-VIII, Div-I, Appen - 8	Vender inspection Report	√	P	W	V	
e	final insection of fabricated components listed in Sr.1 above	Dimensions for Girder, end carriage rope drum etc. Camber, Verticality, bend etc	Major	Dimensional Measurement	100%	Vendor Mfg. Drg.	Vendor Mfg. Drg.	vendor inspection report	√	P	V	V	
f	Heat treatment of rope drum	Stress relieving	Major	Review of SR chart	100%	Approved drawing/relevant standard	Approved drawing/ relevant standard	SR Chart	√	P	V	V	If fabricated from M.S Plate
3	Gear box casing												
a	Material	Surface condition	Major	Visual	100%	Manufacturing drawing	Manufacturing drawing	Vendor inspection Report	√	P	V	V	Refer note 1
		Chemical & mech	Major	Measurement Correlation with T.C. Check test in absesnce of T.C. Correlation	100%	Manufacturing drawing/ IS: 2062	Manufacturing drawing/ IS: 2062	T.C. & I.R.	√	P	V	V	

		MANUFACTURER'S NAME & ADDRESS		STANDARD MANUFACTURING QUALITY PLAN				PROJECT: 2X660 MW TALCHER TPP					
				ITEM:		QP NO :		PACKAGE : DOUBLE GIRDER CRANES					
						REV : 0		CONTRACT NO :					
						DATE :		CONTRACTOR :					
								VENDOR'S QAP No :					
SL. NO.	COMPONENTS & OPERATION	CHARACTERISTICS	CLASS	TYPE OF CHECK	QUANTUM OF CHECK	REFERENCE DOCUMENT	ACCEPTANCE NORMS	FORMAT OF RECORDS	AGENCY			REMARKS	
1	4	3	4	5	6	7	8	9	D*	M	C	N	11
b	Dimension	Dimensional conformity	Major	Measurement	100%	Manufacturing drawing	Manufacturing drawing	Vendor inspection Report		P			
c	Heat treatment	stress relieving	Major	Review of SR chart	100%	Approved drawing/relevant standard	Approved drawing/relevant standard	SR Chart	√	P	V	V	
4	PLATFORMS	Dimensional conformity	Minor	Measurement	100%	Manufacturing drawing	Manufacturing drawing	Vendor inspection Report	√	P	V	V	Refer note: 1
5	L.T.FRAMES	Dimensional conformity	Minor	Measurement	100%	Manufacturing drawing	Manufacturing drawing	Vendor inspection Report	√	P	V	V	
6	HAND RAILINGS	Dimensional conformity	Minor	Measurement	100%	Manufacturing drawing	Manufacturing drawing	Vendor inspection Report	√	P	V	V	
7	CABIN	Dimensional conformity	Minor	Measurement	100%	Manufacturing drawing	Manufacturing drawing	Vendor inspection Report	√	P	V	V	
8	Current collector arms	Dimensional conformity	Minor	Measurement	100%	Mfr. Catalog	Mfr. Catalog	Vendor inspection Report	√	P	V	V	
9	DSL Guard	Dimensional conformity	Minor	Measurement	100%	Manufacturing drawing	Manufacturing drawing	Vendor inspection Report	√	P	V	V	
10	Rails	Dimensional conformity	Minor	Measurement	100%	G.A.drg./IS : 3443 Vendore T.C./Appd.Data Sheet	G.A.drg./IS : 3443 Vendor T.C./Appd.Data Sheet	Vendor inspection Report	√	P	V	V	
		Chemical , tensile & hardness	Major	Chemical & hardness	100%	IS-3443	IS:3443	Manufacturer TC	√	P	V	V	
11	MECHANICAL COMPONENTS												
A	a) wheels												

		MANUFACTURER'S NAME & ADDRESS		STANDARD MANUFACTURING QUALITY PLAN				PROJECT: 2X660 MW TALCHER TPP					
				ITEM:		QP NO :		PACKAGE : DOUBLE GIRDER CRANES					
						REV : 0		CONTRACT NO :					
						DATE :		CONTRACTOR :					
								VENDOR'S QAP No :					
SL. NO.	COMPONENTS & OPERATION	CHARACTERISTICS	CLASS	TYPE OF CHECK	QUANTUM OF CHECK	REFERENCE DOCUMENT	ACCEPTANCE NORMS	FORMAT OF RECORDS		AGENCY		REMARKS	
1	4	3	4	5	6	7	8	9	D*	M**	C 10	N	11
	i) raw material	Chemicals composition and Mechanical Properties.	Major	Corelation with Mfr's TC	100%	Mfg.drg./IS:1570 / BS - 970	Mfg.drg./IS:1570 / BS - 970	Test Certificate	✓	P	V/ W#	V	Refer Note:1. # UTS required for selection of PL value as indicated in Table 6 of IS 3177 shall be witnessed by BHEL.
	ii) Machined	a) Dimensions	Major	Measurement	100%	Manufacturing drawing	Manufacturing drawing	Vendor inspection Report		P	V	V	
		b) Hardness		Mechanical	100%	Approved Data Sheet / Mfg. Drg.	Approved Data Sheet / Mfg. Drg.	Vendor inspection Report	✓	P	V	V	
		c) UT		NDT	100%	ASTM A 388	ASTM A 388	Vendor inspection Report	✓	P	V	V	Refer UT procedure
		d) DPT		NDT	100%	ASME Sec-VIII-App-8	ASME Sec-VIII-App-8	Vendor inspection Report	✓	P	W	V	
	b) Raw material for Gears , Pinions, Shafts,Axles etc	i) Chemicals Composition & heat treatment, Physical Properties.	Major	Correlation with Mfr's TC/ Check test in absence of TC	100%	Manufacturing drawing, BS : 970 / IS : 1570 / Approved Data Sheet	Manufacturing drawing, BS : 970 / IS : 1570 / Approved Data Sheet	Mfr's T.C/ Check Test Report	✓	P	V	V	
		ii) UT (after machining)	Major	check for UT (above)	100%	ASME Sec-V	Refer UT procedure	Vendor inspection Report	✓	P	V	V	
		iii) Hardness	Major	check for Hardness	100%	drg. & Approved Data Sheet	Mfg. drg. & Approved Data Sheet	Vendor inspection Report	✓	P	W	V	Hardness witnessing by BHEL before teeth cutting.
		iv) Dimensions	Major	Measurement	100%	Mfg. Drawing	Mfg. Drawing	Vendor inspection Report	✓	P	V	V	
		v) D.P.Test on teeth	Major	NDT	100%	ASTME-165	No linear indication	Vendor inspection Report	✓	P	V	V	
	c) Casting for Gears and pinions, if applicable	Chemical and Physical	Major	Chemical and Physical	100%	Approved drg/ data sheet	Approved drg/ data sheet	Mfr's T.C	✓	P	V	V	
		NDT	Major	U.T.	100%	ASTM A 388	ASTM A 388	Vendor inspection	✓	P	V	V	Refer UT procedure

		MANUFACTURER'S NAME & ADDRESS		STANDARD MANUFACTURING QUALITY PLAN				PROJECT: 2X660 MW TALCHER TPP				
				ITEM:		QP NO :		PACKAGE : DOUBLE GIRDER CRANES				
						REV : 0		CONTRACT NO :				
						DATE :		CONTRACTOR :				
								VENDOR'S QAP No :				
SL. NO.	COMPONENTS & OPERATION	CHARACTERISTICS	CLASS	TYPE OF CHECK	QUANTUM OF CHECK	REFERENCE DOCUMENT	ACCEPTANCE NORMS	FORMAT OF RECORDS	AGENCY			REMARKS
1	4	3	4	5	6	7	8	9	D*	**	10	11
B	Pulleys, Brake drums, coupling & other major steel castings & forging											
	i) Materials	Physical/Chemical/Hardness	Major	Corelation with mfr's TC	100%	Mfg. Drawing	Mfg. Drawing	Mfr's T.C.	√	P	V	V
	ii) Machined	a) Dimensions	Major	Measurement	100%	Components Drawing	Components Drawing	Vendor inspection Report		P	V	V
		b) DPT after machining.	Major	NDT	100%	ASTM E-165	No linear indication	Vendor inspection Report	√	P	V	V
C	Gear box assy & idle running	Check for oil leakage,Noise level,vibration backlash, rise in temp. after 2 Hrs. of running, reduction ratio, backlash and contact pattern	Major	Visual & Measurement	100%	Vendor standard	Smooth running no oil leakage, Noise 85 db at 1 Mtr. Max. Temp. rise 30°C above amb temp.	Vendor inspection Report	√	P	V	V
D	a) Top block, bottom block	dimensional conformity	Major	Masurement	100%	Assembly drawing	Assembly drawing	Vendor inspection Report		P	V	V
	b) Hook	i) Chemical composition, Heat treatment, Mechanical properties on integral test bar	Major	Chemical, heat treatment & Tensile , % elongation	100%	IS:1875		Test Certificate , HT chart & Insp. Report	√	P	V	V
		ii) UT on raw material of hook	Major	UT	100%	ASME sec--v	Annex-1 (Attached)		√	P	V	V
		iii) Forging operation of hook	Major	Visual	100%	IS:5749 /IS:15560	IS:5749 /IS:15560		√	P	V	V
		iv) Proof load test	Major	Mechanical	100%	IS:5749 /IS:15560	IS:5749 /IS:15560		√	P	W	V
		v) UT & MPI after proof load test	Major	UT & MPI	100%	ASME sec - v & ASTM E709-2007	Annex-1 for UT & No crack & linear indication (For MPI as per ASME Sec VIII Appen 6)		√	P	W	V
		Identification Punch (By BHEL &/or customer, after proof load & NDT witness)	Major	Visual	100%	-----	-----	-----	-	P		CHP - Customer Hold Point

1236331/2023/PS-PEM-MAX

MANUFACTURER'S NAME & ADDRESS		STANDARD MANUFACTURING QUALITY PLAN						PROJECT: 2X660 MW TALCHER TPP				
		ITEM:		QP NO :		PACKAGE : DOUBLE GIRDER CRANES						
				REV : 0		CONTRACT NO :						
				DATE :		CONTRACTOR :						
						VENDOR' S QAP No :						
SL. NO.	COMPONENTS & OPERATION	CHARACTERISTCS	CLASS	TYPE PF CHECK	QUANTUM OF CHECK	REFERENCE DOCUMENT	ACCEPTANCE NORMS	FORMAT OF RECORDS	AGENCY			REMARKS
1	4	3	4	5	6	7	8	9	D*	**	10	11
E	Rope drum assembly	Diemnsion	Major	Measurement	100%	Mfg. Drawing	Tolerance as per drg	Vendor insp Report		P	V	V
12	Electrical components											

		MANUFACTURER'S NAME & ADDRESS		STANDARD MANUFACTURING QUALITY PLAN				PROJECT: 2X660 MW TALCHER TPP					
				ITEM:		QP NO :		PACKAGE : DOUBLE GIRDER CRANES					
						REV : 0		CONTRACT NO :					
						DATE :		CONTRACTOR :					
								VENDOR'S QAP No :					
SL. NO.	COMPONENTS & OPERATION	CHARACTERISTICS	CLASS	TYPE PF CHECK	QUANTUM OF CHECK	REFERENCE DOCUMENT	ACCEPTANCE NORMS	FORMAT OF RECORDS		AGENCY		REMARKS	
1	4	3	4	5	6	7	8	9	D*	M**	C	N	11
a)	Motors (=< 50 KW)	make , type , rating, Routine test	Major	Review mfr's TC	100%	IS:325	IS 325/Mfr's T.C.	Mfr's T.C.	√	P	V	V	Refer Note for motor upto 50 KW.For motor above 50KW separate QP shall be applicable
b)	Brakes	Make , type , rating , dia , Functional test /Routine test	Major	Review mfr's TC	100%	Appd drgs	Appd drgs	Mfr's T.C.	√	P	V	V	
c)	Control panel	Interlocking fuctional, IR, HV, Sheet thickness, cable laying, dressing , ferulling Overall diemsnions , painting shade, Panel surface finish, Paint Thickness, adhesive test, Component fixing, Degree of protection by paper inserting method	CR	Test for HV, IR, functional check	100%	IS : 3177 / App. Panel Drg. & BOM/ Data sheet	IS : 3177 / App. Panel Drg. & BOM/ Data sheet	Vendor insp Report	√	P	W	V	Refer Note No. 4 VVVF Test Certificate to be submitted from app. Vendor for verification.
d)	Radio remote, Master controller	HV, IR,Functional	Major	Verfication	100%	BOM/ Mfr. Catalogue	BOM/ Mfr. Catalogue	Mfr's T.C.	√	P	V	V	Refer Note No. 4
e)	Limit switches	Functional	Major	Verfication	100%	Approved drawings	Approved drawings	Mfr's T.C.	√	P	V	V	
f)	Trailing cable, Power Control Cable & DSL	Make , type , rating ,Routine & acceptance test insulation resistance values	Major	Verfication	100%	IS: 9968, IS 1554-Part-1	IS: 9968, IS 1554-Part-1	Mfr's T.C.	√	P	V	V	
g)	Transformer	make rating , routine test	Major	visual	100%	Appd drg	Appd drg	Mfr's T.C.	√	P	V	V	
h)	SFU, MCCB,MCB, Contactors, DSL, relays, fuses, resitance bank	make, t ype , rating size, functional, continuity check	Major	visual	100%	Appd drg	Appd drg	Mfr's T.C.		P	V	V	
i)	VVVF drives	make , type , rating, routine test	Major	visual	100%	Appd drg	Appd drg	Mfr's T.C.		P	V	V	
j)	Anti collision devices , cable gland , ,lugs ,r ectifier, indicating lamps, terminal blocks, load cell.	make , type	Major	visual	100%	Appd drg	Appd drg	Mfr's T.C.		P	V	V	
13	Bought out items												
a)	Wire rope	Visual , tensile	Major	Type, grade, dia br	100%	IS:2266	IS:2266	Mfr's T.C.	√	P	V	V	
b)	Bearing	Type & Size	Major	Verfication	100%	Appd drg/Mfr's catalogue	Appd drg/Mfr's catalogue	Mfr's T.C.	√	P	V	V	
14	Assembly of cranes												

		MANUFACTURER'S NAME & ADDRESS		STANDARD MANUFACTURING QUALITY PLAN				PROJECT: 2X660 MW TALCHER TPP						
				ITEM:		QP NO :		PACKAGE : DOUBLE GIRDER CRANES						
						REV : 0		CONTRACT NO :						
						DATE :		CONTRACTOR :						
								VENDOR'S QAP No :						
SL. NO.	COMPONENTS & OPERATION	CHARACTERISTICS	CLASS	TYPE PF CHECK	QUANTUM OF CHECK	REFERENCE DOCUMENT	ACCEPTANCE NORMS	FORMAT OF RECORDS	AGENCY			REMARKS		
1	4	3	4	5	6	7	8	9	D*	**	M	C	N	11
a)	Bridge with LT	Dimesions, wheel level alignment	Major	Measurement	100%	GA drg/IS:3177	GA drg/IS:3177	Insp. Report	√	P	W	V		
b)	Crab assembly	Dimesions, wheel level alignment	Major	Measurement/ Vis	100%	GA drg/IS:3177	GA drg/IS:3177	Insp. Report	√	P	W	V		
c)	Final Inspection (at works) with actual panel and pendent	Overall dimension: Span, Diagonal dimension check, Wheel base & gauge, overhang, LT Stopper, headroom, lift , Eqp. Layout on bridge platform, , elevations /levels etc	Major	Measurement	100%	Approved drgs./IS :3177	Approved drgs./IS: 3177	Insp. Report	√	P	W	W		
		No Load & Load Tests												
		a) No load: Hoists,CT & current measurement, No Load running of LT machinery for direction and speed with VVFD	Major	Measurement	100%	Approved drgs	Approved drgs	Insp. Report	√	P	W	W		
		b) SWL: Hoists, CT speed, current & Deflection measurement	Major	Operational Check & Measurement	100%	GA drg/ IS:3177/ Approved Drawing	GA drg/ IS:3177/ Approved Drawing	Insp. Report	√	P	W	W		
		c) Overload: Hoisting, CT movement & current measurment (at 125% SWL)	Major	Operational Check & Measurement	100%	GA drg/ IS:3177/ Approved Drawing	GA drg/ IS:3177/ Approved Drawing	Insp. Report	√	P	W	W		
		d) Operation check of brakes and limit switches .	Major	Operational Check	100%	GA drg/ IS:3177/ Approved Drawing	GA drg/ IS:3177/ Approved Drawing	Insp. Report	√	P	W	W		
15	Painting	Surface preparation & Painting. DFT	Major	Visual	100%	Approved drgs/doc	Approved drgs/doc	Vendor's Report		P	V			
<p>Note 1 : Original TCs / Photocopies certified in original by mill shall be furnished for review. Test In absence of correlated TCs Check test to be witnessed by BHEL shall be carried out from each plate/ bar for above 10 mm thk., certificates shall be offered for review at the time of stage inspection of components / assembly. Supplier shall ensure that pitted material is not used.</p>														
<p>Note 2 : X-Ray to be taken for thickness upto 19 mm and Gamma Ray for thickness above 19 mm. If Gamma Ray is used for lower thickness slow speed film like D2 or equivalent which gives enough readable and interpretable film quality to be used for clarity. All NDT shall be carried out by Qualified Level II personnel.</p>														

MANUFACTURER'S NAME & ADDRESS		STANDARD MANUFACTURING QUALITY PLAN						PROJECT: 2X660 MW TALCHER TPP				
		ITEM:		QP NO :		PACKAGE : DOUBLE GIRDER CRANES						
				REV : 0		CONTRACT NO :						
				DATE :		CONTRACTOR :						
						VENDOR'S QAP No :						
SL. NO.	COMPONENTS & OPERATION	CHARACTERISTICS	CLASS	TYPE PF CHECK	QUANTUM OF CHECK	REFERENCE DOCUMENT	ACCEPTANCE NORMS	FORMAT OF RECORDS	AGENCY			REMARKS
1	4	3	4	5	6	7	8	9	D*	**	10	11
<p>Note 3 : LT motors shall be of type tested quality. For each type & rating of LT motors rated above 30 KW, the bidder shall submit for Owner's approval the reports of all the type tests as per relevant standards and carried out within last ten years from the date of bid opening. These reports should be for the tests conducted on the equipment similar to those proposed to be supplied under this contract and the test(s) should have been either conducted at an independent laboratory or should have been witnessed by a client.</p> <p>In case the Bidder is not able to submit report of the type test(s) conducted within last ten years from the date of bid opening, or in case the type test report(s) are not found to be meeting the specification requirements, the Bidder shall conduct all such tests under this contract free of cost to the Owner and submit the reports for approval.</p> <p>LIST OF TESTS FOR WHICH REPORTS HAVE TO BE SUBMITTED</p> <p>The following type test reports shall be submitted for each type and rating of LT motor of above 30 KW only</p> <ol style="list-style-type: none"> 1. Measurement of resistance of windings of stator and wound rotor. 2. No load test at rated voltage to determine input current power and speed 3. Open circuit voltage ratio of wound rotor motors (in case of Slip ring motors) 4. Full load test to determine efficiency power factor and slip . 5. Temperature rise test . 6. Momentary excess torque test. 7. High voltage test . 8. Test for vibration severity of motor. 9. Test for noise levels of motor 10. Test for degree of protection and 11. Over speed test. <p><u>LESS THAN 30KW:</u> ACCEPTANCE OF MOTOR LESS THAN 30 KW IS BASED ON COC OF THE MANUFACTURER & THE CONTRACTOR CONFIRMING AS FOLLOWS: IT IS HEREBY CONFIRMED THAT THE ABOVE MENTIONED MOTOR /MOTORS WAS/ WERE MANUFACTURED TAKING CARE OF CUSTOMER SPECIFIC REQUIREMENTS REGARDING AMBIENT TEMP., VOLTAGE & FREQUENCY VARIATION, HOT STARTS, PULL OUT TORQUE, STARTING KVA/KW, TEMP. RISE, DISTANCE BETWEEN CENTRE OF STUD & GLAND PLATE AND TESTED IN ACCORDANCE WITH APPROVED DRAWING /DATA SHEETS.</p> <p><u>30 KW TO BELOW 50 KW:</u>ACCEPTANCE OF MOTOR RATING BETWEEN 30 KW & 50 KW IS BASED ON NTPC REVIEW OF ROUTINE TEST INSPECTION REPORT AS PER IS 325 ALONG WITH COC OF THE MANUFACTURER & THE CONTRACTOR CONFIRMING AS FOLLOWS:IT IS HEREBY CONFIRMED THAT THE ABOVE MENTIONED MOTOR /MOTORS WAS/ WERE MANUFACTURED TAKING CARE OF NTPC SPECIFIC REQUIREMENTS REGARDING AMBIENT TEMP., VOLTAGE & FREQUENCY VARIATION, HOT STARTS, PULL OUT TORQUE, STARTING KVA/KW, TEMP. RISE, DISTANCE BETWEEN CENTRE OF STUD & GLAND PLATE, SPACE HEATER AND TESTED IN ACCORDANCE WITH APPROVED DRAWING /DATA SHEETS.</p>												
<p>Note 4 : Performance of electrical & control devices along with the interlocks, protection & sequence to be checked during crane assembly and parked at works.</p>												
<p>Note 5 : All material of construction shall be as per approved drg. / data sheet / specifications</p>												
<p>LEGEND :</p>												
<p>D: RECORDS INDETIFIED WITH 'TICK'(✓) SHALL BE ESSENTIALLY INCLUDED BY CONTRACTOR IN QA DOCUMENTATION</p>												
<p>M : MANUFACTURER/SUBCONTRACTOR</p>												
<p>C: BHEL-CQS/THIRD PARTY</p>												
<p>N : CUSTOMER</p>												
<p>INDICATE "P" PERFORM "W" WITNESS AND "V" DOCUMENT REVIEW</p>												

MANUFACTURER'S NAME & ADDRESS				STANDARD MANUFACTURING QUALITY PLAN				PROJECT: 2X660 MW TALCHER TPP				
				ITEM:				PACKAGE : DOUBLE GIRDER CRANES				
				QP NO :				CONTRACT NO :				
				REV : 0				CONTRACTOR :				
				DATE :				VENDOR' S QAP No :				
SL. NO.	COMPONENTS & OPERATION	CHARACTERISTCS	CLASS	TYPE PF CHECK	QUANTUM OF CHECK	REFERENCE DOCUMENT	ACCEPTANCE NORMS	FORMAT OF RECORDS	AGENCY			REMARKS
1	4	3	4	5	6	7	8	9	D*	**	10	11
MANUFACTURER/ CONTRACTOR												
SUBCONTRACTOR												
SIGNATURE								REVIEWED BY		NAME & SIGN OF APPROVING AUTHORITY & SEAL		



TITLE
2x660MW TALCHER TPP STAGE-III
DOUBLE GIRDER EOT CRANES ABOVE 100T
SPECIFIC TECHNICAL REQUIREMENTS

SPECIFICATION NO. PE-TS-497-501-A501
 REV 00
 Section I B Date DEC'22
 Page 1 of 1

SUB-SECTION IB
SPECIFIC TECHNICAL REQUIREMENT (ELECTRICAL)

1236331/2023/PS-PEM-MAX

ELECTRICAL EQUIPMENT SPECIFICATION
FOR
DG EOT CRANE

2X660 MW TALCHER THERMAL POWER PROJECT

SPECIFICATION NO.
PE_TS_497_501_A501

VOLUME NO. : II-B

SECTION : C

REV NO.: 00 DATE: 26.12.22

SHEET : 1 OF 3

TECHNICAL SPECIFICATION

FOR

DG EOT CRANE

(ELECTRICAL PORTION)

**ELECTRICAL EQUIPMENT SPECIFICATION
FOR
DG EOT CRANE**

2X660 MW TALCHER THERMAL POWER PROJECT

SPECIFICATION NO.
PE_TS_497_501_A501

VOLUME NO. : **II-B**

SECTION : **C**

REV NO.: **00** DATE: 26.12.22

SHEET : 2 OF 3

1.0 EQUIPMENT & SERVICES TO BE PROVIDED BY BIDDER:

- a) Services and equipment as per “Electrical Scope between BHEL and Vendor”.
- b) Any item/work either supply of equipment or erection material which have not been specifically mentioned but are necessary to complete the work for trouble free and efficient operation of the plant shall be deemed to be included within the scope of this specification. The same shall be provided by the bidder without any extra charge.
- c) Supply of mandatory spares as specified in the specifications of mechanical equipments.
- d) Erection and Commissioning spares.
- e) Erection & Maintenance tools & tackles.
- f) Electrical load requirement for **DG EOT** system.
- g) All equipment shall be suitable for the power supply fault levels and other climatic conditions mentioned in the enclosed project information.
- h) Bidder to furnish list of makes for each equipment at contract stage, which shall be subject to customer/BHEL approval without any commercial and delivery implications to BHEL
- i) Various drawings, data sheets as per required format, Quality plans, calculations, test reports, test certificates, operation and maintenance manuals etc shall be furnished as specified at contract stage. All documents shall be subject to customer/BHEL approval without any commercial implication to BHEL.
- j) Motor shall meet minimum requirement of motor specification.
- k) LT power & control cables shall meet minimum requirement of LT power & control cables specification.
- l) Cabling, earthing & lightning protection shall meet minimum requirement of cabling, earthing & lightning protection specification.

2.0 EQUIPMENT & SERVICES TO BE PROVIDED BY PURCHASER FOR ELECTRICAL & TERMINAL POINTS:

Refer “Electrical Scope between BHEL and Vendor”.

3.0 DOCUMENTS TO BE SUBMITTED ALONG WITH BID

- 3.1 Bidder shall confirm total compliance to the electrical specification without any deviation from the technical/quality assurance requirements stipulated. In line with this two signed and stamped copies of the following shall be furnished by the bidder as technical offer:
 - a) A copy of this sheet” Electrical equipment Specification for **DG EOT CRANE** and sheet “Electrical Scope between BHEL and Vendor” with bidder’s signature and company stamp.
 - b) List of Erection and Commissioning spares.
 - c) List of Erection & Maintenance tools & tackles.
 - d) Electrical load requirement
- 3.2 No technical submittal such as copies of data sheets, drawings, write-up, quality plans, type test certificates, technical literature, etc, is required during tender stage. Any such submission even if made, shall not be considered as part of offer.

1236331/2023/PS-PEM-MAX

**ELECTRICAL EQUIPMENT SPECIFICATION
FOR
DG EOT CRANE**

2X660 MW TALCHER THERMAL POWER PROJECT

SPECIFICATION NO.
PE_TS_497_501_A501

VOLUME NO. : **II-B**

SECTION : **C**

REV NO.: **00** DATE: 26.12.22

SHEET : 3 OF 3

4.0 List of enclosures:

- a) Electrical scope between BHEL & vendor.
- b) Technical specification, datasheets & quality plans for 415V Electric motors.
- c) Technical Specification, datasheets & quality plans for LT power & control cables.
- d) Technical Specification, datasheets & quality plans & quality assurance for cabling, earthing & lightning protection.
- e) Electrical Load data format.
- f) Cable Listing Format
- g) Cable listing philosophy.

Note: The requirements mentioned in Customer Motor Spec for Motors shall prevail in case of conflict between the same and the corresponding requirements mentioned in the Section C/ Section D/ Datasheet A

STANDARD ELECTRICAL SCOPE BETWEEN BHEL AND VENDOR (FOR EPC PROJECTS)

PACKAGE: DOUBLE GRIDER EOT CRANES

SCOPE OF VENDOR: SUPPLY , ERECTION & COMMISSIONING OF VENDOR'S EQUIPMENT

PROJECT : 2 X 660 MW TALCHER TPP STAGE-III (EPC)

<u>S. NO</u>	<u>DETAILS</u>	<u>SCOPE SUPPLY</u>	<u>SCOPE E&C</u>	<u>REMARKS</u>
1	Isolating Switch	Vendor	Vendor	BHEL will provide one number 415 V (3ph, 4W) supply feeder only up to isolating switches for cranes. Any other voltage level (AC/DC) required will be derived by the vendor. Motor starter shall be part of crane control panel.
2	Power cables, control cables, screened control cables and any special cables (if required) between equipment supplied by vendor.	Vendor	Vendor	Cable from supply feeder to isolating switch shall be in BHEL scope.
3	Cabling material (cable trays, accessories, cable tray supporting system, conduits etc).	Vendor	Vendor	
4	Equipment Earthing	Vendor	Vendor	All equipment metallic enclosures / frames, metal structure etc. shall be grounded at two points each to the nearest grounding points / risers provided by BHEL.
5	Motors	Vendor	Vendor	
6	Cable glands and lugs for equipment supplied by vendor	Vendor	Vendor	<ol style="list-style-type: none"> 1. Double compression Ni-Cr plated brass cable glands 2. Solder less crimping type heavy duty tinned copper lugs for power & control cables.
7	<ol style="list-style-type: none"> a) Input cable schedules (C & I) b) Cable interconnection details for above c) Cable block diagram 	Vendor Vendor Vendor	- - -	Cable listing for Control and Instrumentation Cable in enclosed excel format shall be submitted by vendor during detailed engineering stage.
8	Equipment layout drawings	Vendor	-	
9	Electrical Equipment GA drawing	Vendor	-	For necessary interface review.



SUB-SECTION-B – 02

MOTORS

TALCHER THERMAL POWER PROJECT STAGE-III (2X660 MW)
EPC PACKAGE
BID DOC NO.: CS-4540-001A-2

TECHNICAL SPECIFICATION
SECTION - VI
PART-B

CLAUSE NO.	TECHNICAL REQUIREMENTS																											
	<p style="text-align: center;">MOTORS</p> <p>1.00.00 GENERAL REQUIREMENTS</p> <p>1.01.00 This chapter has to be read in conjunction with sub-section B-0 "General electrical specification" of Technical specification Section- VI, Part-B and Sub-Section-IIB Electrical system/Equipment of Technical Specifications Section-VI, Part-A"</p> <p>Degree of Protection</p> <p>Degree of protection for various enclosures as per IEC60034-05 shall be as follows :-</p> <table border="0"> <tr> <td>i) Indoor motors</td> <td>-</td> <td>IP 55</td> </tr> <tr> <td>ii) Outdoor motors</td> <td>-</td> <td>IP 55 (Additional Canopy to be provided)</td> </tr> <tr> <td>iii) Cable box-indoor area</td> <td>-</td> <td>IP 55</td> </tr> <tr> <td>iv) Cable box-Outdoor area</td> <td>-</td> <td>IP 55</td> </tr> </table> <p>2.00.00 CODES AND STANDARDS</p> <table border="0"> <tr> <td>1) Three phase induction motors</td> <td>:</td> <td>IS15999/IEC:60034</td> </tr> <tr> <td>2) Single phase AC motors</td> <td>:</td> <td>IS 996/ IEC:60034</td> </tr> <tr> <td>3) Crane duty motors</td> <td>:</td> <td>IS:3177, IEC:60034</td> </tr> <tr> <td>4) DC motors/generators</td> <td>:</td> <td>IS:4722, IEC:60034</td> </tr> <tr> <td>5) Energy Efficient motors</td> <td>:</td> <td>IS 12615, IEC:60034-30</td> </tr> </table> <p>3.00.00 TYPE</p> <p>3.01.00 AC Motors:</p> <p>a) Squirrel cage induction motor suitable for direct-on-line starting.</p> <p>b) Continuous duty LT motors upto 200 KW Output rating (at 50 deg.C ambient temperature), shall be Premium Efficiency class-IE3, conforming to IS 12615, or IEC:60034-30. HT motors shall have minimum design efficiency of 95 %. However, tolerance on this efficiency value shall be applicable as per IEC 60034</p> <p>c) Motor operating through variable frequency drives shall be suitable for inverter duty with VPI insulation. Also these motors shall comply the requirements stipulated in IEC: 60034-18-41 and IEC: 60034-18-42 as applicable.</p> <p>3.02.00 DC Motors: Shunt wound.</p> <p>4.00.00 RATING</p> <p>(a) Continuously rated (S1). However, crane motors shall be rated for S4 duty, 40% cyclic duration factor.</p> <p>(b) Whenever the basis for motor or driven equipment ratings are not specified in the corresponding mechanical specification sub-sections, maximum continuous motor ratings shall be at least 10% above the maximum load demand of the driven equipment under entire operating range including voltage and frequency variations.</p> <p>5.00.00 TEMPERATURE RISE</p> <p>Air cooled motors</p> <p>70 deg. C by resistance method for both thermal class 130(B) & 155(F) insulation.</p> <p>Water cooled</p> <p>80 deg. C over inlet cooling water temperature mentioned elsewhere, by resistance method for both thermal class 130(B) & 155(F) insulation.</p>	i) Indoor motors	-	IP 55	ii) Outdoor motors	-	IP 55 (Additional Canopy to be provided)	iii) Cable box-indoor area	-	IP 55	iv) Cable box-Outdoor area	-	IP 55	1) Three phase induction motors	:	IS15999/IEC:60034	2) Single phase AC motors	:	IS 996/ IEC:60034	3) Crane duty motors	:	IS:3177, IEC:60034	4) DC motors/generators	:	IS:4722, IEC:60034	5) Energy Efficient motors	:	IS 12615, IEC:60034-30
i) Indoor motors	-	IP 55																										
ii) Outdoor motors	-	IP 55 (Additional Canopy to be provided)																										
iii) Cable box-indoor area	-	IP 55																										
iv) Cable box-Outdoor area	-	IP 55																										
1) Three phase induction motors	:	IS15999/IEC:60034																										
2) Single phase AC motors	:	IS 996/ IEC:60034																										
3) Crane duty motors	:	IS:3177, IEC:60034																										
4) DC motors/generators	:	IS:4722, IEC:60034																										
5) Energy Efficient motors	:	IS 12615, IEC:60034-30																										
<p style="text-align: center;">TALCHER THERMAL POWER PROJECT STAGE-III (2X660 MW) EPC PACKAGE</p>	<p style="text-align: center;">TECHNICAL SPECIFICATION SECTION – VI, PART-B BID DOC NO : CS-4540-001A-2 Page 117 of 368</p>	<p style="text-align: center;">SUB SECTION-II-B-02 MOTORS</p>	<p style="text-align: center;">PAGE 1 OF 4</p>																									

CLAUSE NO.	TECHNICAL REQUIREMENTS		
6.00.00	OPERATIONAL REQUIREMENTS		
6.01.00	Starting Time		
6.01.01	For motors with starting time upto 20 secs. at minimum permissible voltage during starting, the locked rotor withstand time under hot condition at highest voltage limit shall be at least 2.5 secs. more than starting time.		
6.01.02	For motors with starting time more than 20 secs. and upto 45 secs. at minimum permissible voltage during starting, the locked rotor withstand time under hot condition at highest voltage limit shall be at least 5 secs. more than starting time.		
6.01.03	For motors with starting time more than 45 secs. at minimum permissible voltage during starting, the locked rotor withstand time under hot condition at highest voltage limit shall be more than starting time by at least 10% of the starting time.		
6.01.04	Speed switches mounted on the motor shaft shall be provided in cases where above requirements are not met.		
6.02.00	Torque Requirements		
6.02.01	Accelerating torque at any speed with the lowest permissible starting voltage shall be at least 10% motor rated torque.		
6.02.02	Pull out torque at rated voltage shall not be less than 205% of rated torque. It shall be 275% for crane duty motors.		
6.03.00	NOT USED.		
7.00.00	DESIGN AND CONSTRUCTIONAL FEATURES		
7.01.00	Suitable single phase space heaters shall be provided on motors rated 30KW and above to maintain windings in dry condition when motor is standstill. Separate terminal box for space heaters & RTDs shall be provided. However for flame proof motors, space heater terminals inside the main terminal box may be acceptable.		
7.02.00	<p>All motors shall be either Totally enclosed fan cooled (TEFC) or totally enclosed tube ventilated (TETV) or Closed air circuit air cooled (CACWA) type. However, motors rated 3000KW or above can be Closed air circuit water cooled (CACW). The method of movement of primary and secondary coolant shall be self-circulated by fan or pump directly mounted on the rotor of the main motor as per IEC 60034-6. However VFD driven motors can be offered with forced cooling type with machine mounted fan or pump driven by separate electric motor. Motors and EPB located in hazardous areas shall have flame proof enclosures conforming to IS:2148 as detailed below</p> <p>(a) Fuel oil area : Group – IIB</p> <p>(b) Hydrogen generation : Group - IIC or (Group-I, Div-II as per plant area NEC) or (Class-1, Group-B, Div-II as per NEMA /IEC60034)</p>		
7.03.00	<p>Winding and Insulation</p> <p>Type : Electrolytic grade Copper conductor, Non-hygroscopic, oil resistant, flame resistant Insulation.</p> <p>Starting duty : Two hot starts in succession, with motor initially at normal running temperature.</p> <p>However, conveyor motors shall be suitable for 3 consecutive hot starts</p> <p>11kV, 6.6 KV & 3.3 kV AC motors : Thermal class 155 (F) insulation. The winding insulation process shall be total Vacuum Pressure Impregnated i.e resin poor method. The lightning Impulse & interturn insulation surge withstand level shall be as per IEC-60034 part-15.</p>		
<p>TALCHER THERMAL POWER PROJECT STAGE-III (2X660 MW) EPC PACKAGE</p>	<p>TECHNICAL SPECIFICATION SECTION – VI, PART-B BID DOC NO : CS-4540-001A-2 Page 118 of 368</p>	<p>SUB SECTION-II-B-02 MOTORS</p>	<p>PAGE 2 OF 4</p>

CLAUSE NO.	TECHNICAL REQUIREMENTS		
	<p>240VAC, : Thermal Class (F) or better 415V AC & 220V DC motors</p>		
7.04.00	Motors rated above 1000KW shall have insulated bearings/housing to prevent flow of shaft currents.		
7.05.00	Motors with heat exchangers shall have dial type thermometer with adjustable alarm contacts to indicate inlet and outlet primary air temperature.		
7.06.00	Noise level for all the motors shall be limited to 85 dB(A) except for BFP motor for which the maximum limit shall be 90dB(A). Vibration shall be limited within the limits prescribed in IS:12075 / IEC 60034-14 . Motors shall withstand vibrations produced by driven equipment. HT motor bearing housings shall have flat surfaces, in both X and Y directions, suitable for mounting vibration pads.		
7.07.00	In HT motors, at least four numbers simplex / two numbers duplex platinum resistance type temperature detectors shall be provided in each phase stator winding. Each bearing of HT motor shall be provided with three numbers duplex RTDs connected to three numbers dual input transmitters with display. However for air compressor, being high speed drive, each motor bearing shall be provided with minimum two numbers of duplex RTDs connected to two numbers dual input transmitters with display unit.7.08.00 Motor body shall have two earthing points on diagonally opposite sides.		
7.09.00	11 KV motors shall be offered with Separable Insulated Connector (SIC) as per IEEE 386. The offered SIC terminations shall be provided with protective cover and trifurcating sleeves. SIC termination kit shall be suitable for fault level of 25 KA for 0.17 seconds.		
7.10.00	3.3/6.6 KV motors shall be offered with dust tight phase segregated double walled (metallic as well as insulated barrier) Terminal box. Contractor shall provide termination kit for the offered Terminal box. The offered Terminal Box shall be suitable for fault level of 250 MVA for 0.12 sec. Removable gland plates of thickness 3 mm (hot/cold rolled sheet steel) or 4 mm (non magnetic material for single core cables) shall be provided.		
7.11.00	The spacing between gland plate & centre of bottom terminal stud shall be as per Table-I.		
7.12.00	All motors shall be so designed that maximum inrush currents and locked rotor and pullout torque developed by them at extreme voltage and frequency variations do not endanger the motor and driven equipment.		
7.13.00	The motors shall be suitable for bus transfer schemes provided on the 11kV, 6.6 KV, 3.3 KV /415V systems without any injurious effect on its life.		
7.14.00	For motors rated 2000 KW & above, neutral current transformers of PS class shall be provided on each phase in a separate neutral terminal box.		
7.15.00	NOT USED		
8.00.00	NOT USED		
10.00.00	TYPE TEST		
10.01.00	<p>HT MOTORS</p> <p>LIST OF TYPE TESTS TO BE CONDUCTED</p> <p>The following type tests shall be conducted on each type and rating of HT motor</p> <p>(a) No load saturation and loss curves upto approximately 115% of rated voltage</p> <p>(b) Measurement of noise at no load.</p> <p>(c) Momentary excess torque test (subject to test bed constraint).</p> <p>(d) Full load test(subject to test bed constraint)</p>		
<p>TALCHER THERMAL POWER PROJECT STAGE-III (2X660 MW) EPC PACKAGE</p>	<p>TECHNICAL SPECIFICATION SECTION – VI, PART-B BID DOC NO : CS-4540-001A-2 Page 119 of 368</p>	<p>SUB SECTION-II-B-02 MOTORS</p>	<p>PAGE 3 OF 4</p>

CLAUSE NO.	TECHNICAL REQUIREMENTS		
10.02.00	<p>(e) Temperature rise test at rated conditions. During heat run test, bearing temp., winding temp., coolant flow and its temp. shall also be measured. In case the temperature rise test is carried at load other than rated load, specific approval for the test method and procedure is required to be obtained. Wherever ETD's are provided, the temperature shall be measured by ETD's also for the record purpose.</p> <p>LIST OF TESTS FOR WHICH REPORTS HAVE TO BE SUBMITTED</p> <p>The following type test reports shall be submitted for each type and rating of HT motor</p> <p>(a) Degree of protection test for the enclosure followed by IR, HV and no load run test.</p> <p>(b) Terminal box-fault level withstand test for each type of terminal box of HT motors only.</p> <p>(c) Lightning Impulse withstand test on the sample coil shall be as per clause no. 4.3 IEC-60034, part-15</p> <p>(d) Surge-withstand test on inter-turn insulation shall be as per clause no. 4.2 of IEC 60034, part-15</p> <p>LT Motors</p> <p>LIST OF TESTS FOR WHICH REPORTS HAVE TO BE SUBMITTED</p> <p>The following type test reports shall be submitted for each type and rating of LT motor of above 100 KW only</p> <ol style="list-style-type: none"> 1. Measurement of resistance of windings of stator and wound rotor. 2. No load test at rated voltage to determine input current power and speed 3. Open circuit voltage ratio of wound rotor motors (in case of Slip ring motors) 4. Full load test to determine efficiency power factor and slip 5. Temperature rise test 6. Momentary excess torque test. 7. High voltage test 8. Test for vibration severity of motor. 9. Test for noise levels of motor(Shall be limited as per clause no 7.06.00 of this section) 10. Test for degree of protection and 11. Overspeed test. 12. Type test reports for motors located in fuel oil area having flame proof enclosures as per IS 2148 / IEC 60079-1 		
10.03.00	All acceptance and routine tests as per the specification and relevant standards shall be carried out. Charges for these shall be deemed to be included in the equipment price.		
10.04.00	The type test reports once approved for any projects shall be treated as reference. For subsequent projects of NTPC, an endorsement sheet will be furnished by the manufacturer confirming similarity and "No design Change". Minor changes if any shall be highlighted on the endorsement sheet.		
TALCHER THERMAL POWER PROJECT STAGE-III (2X660 MW) EPC PACKAGE	TECHNICAL SPECIFICATION SECTION – VI, PART-B BID DOC NO : CS-4540-001A-2 Page 120 of 368	SUB SECTION-II-B-02 MOTORS	PAGE 4 OF 4





SUB-SECTION-B – 08

HT LT & CONTROL CABLES

TALCHER THERMAL POWER PROJECT STAGE-III (2X660 MW)
EPC PACKAGE
BID DOC NO.: CS-4540-001A-2

TECHNICAL SPECIFICATION
SECTION - VI
PART-B

CLAUSE NO.	TECHNICAL REQUIREMENTS			
<p>1.00.00</p>	<p align="center">HT & LT POWER CABLES & control cables</p> <p>This chapter has to be read in conjunction with sub-section B-0 "General electrical specification" of Technical specification Section- VI, Part-B and Sub-Section-IIB Electrical system/Equipment of Technical Specifications Section-VI, Part-A".</p> <p>CODES AND STANDARDS</p> <p>All standards, specifications and codes of practice referred to herein shall be the latest editions including all applicable official amendments and revisions as on date of opening of bid. In case of conflict between this specification and those (IS: codes, standards, etc.) referred to herein, the former shall prevail. All the cables shall conform to the requirements of the following standards and codes :</p> <p>IS:7098 (Part -II) Specification for Cross linked polyethylene insulated PVC sheathed cables. Part-II: For working voltages from 3.3 KV upto and including 33 KV.</p> <p>IS : 3975 Low Carbon Galvanized steel wires, formed wires and tapes for armouring of cables.</p> <p>IS :4905 Methods for random sampling.</p> <p>IS : 5831 PVC insulation and sheath of electrical cables.</p> <p>IS : 8130 Conductors for insulated electrical cables and flexible cords.</p> <p>IS : 10418 Specification for drums for electric cables.</p> <p>IS : 10810 Methods of tests for cables.</p> <p>ASTM-D - 2843 Standard test method for density of smoke from the burning or decomposition of plastics.</p> <p>IEC-754 (Part-I) Tests on gases evolved during combustion of electric cables.</p> <p>IS :1554 - I PVC insulated (heavy duty) electric cables for working voltages upto and including 1100V.</p> <p>IS : 3961 Recommended current ratings for cables</p> <p>IEC- 332 Tests on electric cables under fire conditions. Part-3: Tests on bunched wires or cables (Category-B).</p> <p>IS:7098 (Part -I) Cross linked polyethylene insulated PVC sheathed cables for working voltages upto and including 1100V.</p>			
<p>2.00.00</p> <p>2.01.00</p>	<p>TECHNICAL REQUIREMENTS</p> <p>All cables (HT Power, LT power and control cables) shall be armoured type only irrespective of anything contrary mentioned elsewhere in the specification. All cables including EPR cables</p>			
<p align="center">TALCHER THERMAL POWER PROJECT STAGE-III (2X660 MW) EPC PACKAGE</p>	<p align="center">TECHNICAL SPECIFICATIONS SECTION VI, PART-B BID DOC. NO.:CS-4540-001A-2</p>	<p align="center">SUB-SECTION-B-08 HT LT AND CONTROL CABLES</p>	<p align="center">PAGE 1 OF 6</p>	

CLAUSE NO.	TECHNICAL REQUIREMENTS																
	<p>shall be flame retardant, low smoke (FRLS) type designed to withstand all mechanical, electrical and thermal stresses developed under steady state and transient operating conditions as specified elsewhere in this specification.</p>																
2.02.00	Aluminium conductor used in power cables shall have tensile strength of more than 100 N/ sq.mm. Conductors shall be multi stranded.																
2.03.00	XLPE insulation shall be suitable for a continuous conductor temperature of 90 deg. C and short circuit conductor temperature of 250 deg C. PVC insulation shall be suitable for continuous conductor temperature of 70 deg C and short circuit conductor temperature of 160 deg. C.																
2.04.00	The cable cores shall be laid up with fillers between the cores wherever necessary. It shall not stick to insulation and inner sheath. All the cables, other than single core unarmoured cables, shall have distinct extruded PVC inner sheath of black colour as per IS: 5831.																
2.05.00	<p>For single core armoured cables, armouring shall be of aluminium wires. For multicore armoured cables armouring shall be of galvanised steel as follows : -</p> <table border="1" data-bbox="407 726 1203 1367"> <thead> <tr> <th data-bbox="407 726 862 789">Calculated nominal dia of cable under armour</th> <th data-bbox="862 726 1203 789">Size and Type of armour</th> </tr> </thead> <tbody> <tr> <td data-bbox="407 810 862 852">i) Upto 13 mm</td> <td data-bbox="862 810 1203 852">1.4mm dia GS wire</td> </tr> <tr> <td data-bbox="407 873 862 936">ii) Above 13 & upto 25mm</td> <td data-bbox="862 873 1203 936">0.8 mm thick GS formed wire / 1.6 mm dia GS wire</td> </tr> <tr> <td data-bbox="407 978 862 1041">iii) Above 25 & upto 40 mm</td> <td data-bbox="862 978 1203 1041">0.8mm thick GS formed wire / 2.0mm dia GS wire</td> </tr> <tr> <td data-bbox="407 1083 862 1146">iv) Above 40 & upto 55mm</td> <td data-bbox="862 1083 1203 1146">1.4 mm thick GS formed wire/2.5mm dia GS wire</td> </tr> <tr> <td data-bbox="407 1188 862 1251">v) Above 55 & upto 70mm</td> <td data-bbox="862 1188 1203 1251">1.4 mm thick GS formed wire/3.15mm dia GS wire</td> </tr> <tr> <td data-bbox="407 1293 862 1356">vi) Above 70mm</td> <td data-bbox="862 1293 1203 1356">1.4 mm thick GS formed wire / 4.0 mm dia GS wire</td> </tr> </tbody> </table>	Calculated nominal dia of cable under armour	Size and Type of armour	i) Upto 13 mm	1.4mm dia GS wire	ii) Above 13 & upto 25mm	0.8 mm thick GS formed wire / 1.6 mm dia GS wire	iii) Above 25 & upto 40 mm	0.8mm thick GS formed wire / 2.0mm dia GS wire	iv) Above 40 & upto 55mm	1.4 mm thick GS formed wire/2.5mm dia GS wire	v) Above 55 & upto 70mm	1.4 mm thick GS formed wire/3.15mm dia GS wire	vi) Above 70mm	1.4 mm thick GS formed wire / 4.0 mm dia GS wire		
Calculated nominal dia of cable under armour	Size and Type of armour																
i) Upto 13 mm	1.4mm dia GS wire																
ii) Above 13 & upto 25mm	0.8 mm thick GS formed wire / 1.6 mm dia GS wire																
iii) Above 25 & upto 40 mm	0.8mm thick GS formed wire / 2.0mm dia GS wire																
iv) Above 40 & upto 55mm	1.4 mm thick GS formed wire/2.5mm dia GS wire																
v) Above 55 & upto 70mm	1.4 mm thick GS formed wire/3.15mm dia GS wire																
vi) Above 70mm	1.4 mm thick GS formed wire / 4.0 mm dia GS wire																
2.05.01	The aluminium used for armouring shall be of H4 grade as per IS: 8130 with maximum resistivity of 0.028264 ohm-sq.mm/mtr at 20 deg.C. The types and sizes of aluminium armouring shall be same as mentioned for galvanised steel at 2.05.00 above.																
2.05.02	The gap between armour wires / formed wires shall not exceed one armour wire / formed wire space and there shall be no cross over / over-riding of armour wire / formed wire. The minimum area of coverage of armouring shall be 90%. The breaking load of armour joint shall not be less than 95% of that of armour wire / formed wire. Zinc rich paint shall be applied on armour joint surface of G.S.wire/ formed wire.																
2.06.00	<p>Distinct extruded PVC inner sheath of black colour as per IS:5831 shall be provided for the cables as follows:</p> <ol style="list-style-type: none"> <li data-bbox="386 1713 740 1745">For all multicore cables. <li data-bbox="386 1755 1422 1808">For single core armoured cables, where armouring is not being used as metallic screen. 																
<p>TALCHER THERMAL POWER PROJECT STAGE-III (2X660 MW) EPC PACKAGE</p>	<p>TECHNICAL SPECIFICATIONS SECTION VI, PART-B BID DOC. NO.:CS-4540-001A-2</p>	<p>SUB-SECTION-B-08 HT LT AND CONTROL CABLES</p>	<p>PAGE 2 OF 6</p>														

CLAUSE NO.	TECHNICAL REQUIREMENTS		
2.07.00	<p>Outer sheath shall be of PVC black in colour. In addition to meeting all the requirements of Indian standards referred to, outer sheath of all the cables shall have the following FRLS properties.</p> <p>(a.) Oxygen index of min. 29 (Test method as per IS 10810 Part-58)</p> <p>(b.) Acid gas emission of max. 20% as per IEC-754 (Part-I)</p> <p>(c.) Smoke density rating shall not be more than 60% during Smoke Density Test as per ASTM-D-2843.</p>		
2.08.00	Allowable tolerances on the overall diameter of the cables shall be ± 2 mm maximum over the declared value in the technical data sheets.		
2.09.00	Cable lengths shall be considered in such a way that straight through cable joints is avoided.		
2.10.00	All Cables shall be armoured type only.		
2.11.00	<p>All LT power cables of sizes more than 120 sq.mm. shall be XLPE insulated and sizes shall be of 1Cx150, 1Cx300, 1Cx630, 3Cx150 & 3Cx240 sq.mm However for cable sizes upto 120 sq.mm. both XLPE insulated & PVC insulated LT power cables are acceptable. For LT cables, Same cable sizes to be used for same type & rating of motor i.e if there are three pumps for one application, all three pumps motor should be provided with same cables sizes</p>		
2.12.00	<p>Cores of the cables shall be identified by colouring of insulation. Following colour scheme shall be adopted:</p> <p>1 core - Red, Black, Yellow or Blue</p> <p>2 core - Red & Black</p> <p>3 core - Red, Yellow & Blue</p> <p>4 core - Red, Yellow, Blue and Black</p>		
2.13.00	For reduced neutral conductors, the core shall be black.		
2.14.00	In plant repairs to the cables shall not be accepted. Pimples, fish eye, blow holes etc. are not acceptable.		
2.15.00	The cross-sectional area of the metallic screen strip/tape/wires shall be considered in sizing calculations.		
2.16.00	The eccentricity of the core shall not exceed 10% and ovality not to exceed 2%.		
3.00.00	CABLE SELECTION & SIZING		
3.00.01	<p>Cables shall be sized based on the following considerations:</p> <p>a) Rated current of the equipment</p> <p>b) The voltage drop in the cable, during motor starting condition, shall be limited to 10% and during full load running condition, shall be limited to 3% of the rated voltage</p> <p>c) Short circuit withstand capability</p>		
3.00.02	<p>Derating Factors</p> <p>Derating factors for various conditions of installations including the following shall be considered while selecting the cable sizes:</p> <p>a) Variation in ambient temperature for cables laid in air</p> <p>b) Grouping of cables</p>		
TALCHER THERMAL POWER PROJECT STAGE-III (2X660 MW) EPC PACKAGE	TECHNICAL SPECIFICATIONS SECTION VI, PART-B BID DOC. NO.:CS-4540-001A-2	SUB-SECTION-B-08 HT LT AND CONTROL CABLES	PAGE 3 OF 6

CLAUSE NO.	TECHNICAL REQUIREMENTS		
<p>4.00.00</p> <p>4.00.01</p> <p>4.00.02</p> <p>4.00.03</p> <p>4.00.03</p> <p>4.00.04</p> <p>4.00.04.01</p>	<p>c) Variation in ground temperature and soil resistivity for buried cables.</p> <p>The bidder shall furnish detailed cable selection/sizing criteria for Employer's approval.</p> <p>CONSTRUCTIONAL FEATURES</p> <p>19/33, 11/11 KV Grade Power Cables:</p> <p>Cables shall conform to IS 7098 Part-II. These cables shall be multi-stranded, compacted circular aluminium conductor, XLPE-insulated, metallic screened PVC outer sheathed. The conductor screen and insulation screen shall both be of extruded semiconducting compound and shall be applied along with the XLPE insulation in a single operation of triple extrusion process so as to obtain continuously smooth interfaces. Method of curing for 33/33 KV Cables shall be "dry curing / gas curing ". The metallic screen for each core shall be capable of carrying the system earth fault current and shall consist of copper wires or tape with minimum overlap of 20%. However, for single core armoured cables, the armouring shall constitute the metallic part of the screening.</p> <p>3.3/3.3kV Grade Power Cables:</p> <p>Cables shall conform to IS: 7098 Part - II. These cables shall be multi- stranded, compacted circular aluminium conductor, XLPE insulated, metallic screened, PVC outer sheathed. The metallic screen of each core shall consist of copper wires or tape with minimum overlap of 20%. However, for single core armoured cables, the armouring shall constitute the metallic part of the screening. The metallic screen of each core shall be capable of carrying the system earth fault current Method of curing for cables shall be "dry curing / gas curing / steam curing".</p> <p>Trailing cables shall have tinned copper (class 5) conductor, insulated with heat resistant elastomeric compound based on Ethylene Propylene Rubber (EPR) suitable for withstanding 90 deg.C continuous conductor temperature and 250deg C during short circuit, inner-sheathed with heat resistant elastomeric compound, nylon cord reinforced, outer-sheathed with heat resistant, oil resistant and flame retardant heavy duty elastomeric compound conforming to IS 9968</p> <p>1.1 KV Grade Power Cables</p> <p>(a) 1.1 KV grade XLPE power cables shall have compacted aluminium conductor, XLPE insulated, PVC inner-sheathed (as applicable), armoured-PVC outer-sheathed conforming to IS: 7098. (Part-I).</p> <p>(b) 1.1KV grade PVC power cables shall have aluminium conductor (compacted type for sizes above 10 sq.mm), PVC Insulated, PVC inner sheathed (as applicable) armoured, PVC outer-sheathed conforming to IS:1554 (Part-I).</p> <p>(c) 1.1 KV grade Trailing cables shall have tinned copper(class 5) conductor, insulated with heat resistant elastomeric compound based on Ethylene Propylene Rubber(EPR) suitable for withstanding 90 deg.C continuous conductor temperature and 250deg C during short circuit, inner-sheathed with heat resistant elastomeric compound, nylon cord reinforced, outer-sheathed with heat resistant, oil resistant and flame retardant heavy duty elastomeric compound conforming to IS 9968.</p> <p>CABLE DRUMS</p> <p>Cables shall be supplied in steel drums of heavy construction. The drum shall be designed on the basis of weight, diameter, bending radius and length of cable. The surface of the drum and the outer most cable layer shall be covered with water proof cover. Both the ends of the</p>		
<p>TALCHER THERMAL POWER PROJECT STAGE-III (2X660 MW) EPC PACKAGE</p>	<p>TECHNICAL SPECIFICATIONS SECTION VI, PART-B BID DOC. NO.:CS-4540-001A-2</p>	<p>SUB-SECTION-B-08 HT LT AND CONTROL CABLES</p>	<p>PAGE 4 OF 6</p>

CLAUSE NO.	TECHNICAL REQUIREMENTS																																												
	<p>cables shall be properly sealed with heat shrinkable PVC/ rubber caps secured by 'U' nails so as to eliminate ingress of water during transportation, storage and erection.</p>																																												
4.00.04.02	<p>Each drum shall carry manufacturer's name, purchaser's name, address and contract number, item number and type, size and length of cable and net gross weight stenciled on both sides of the drum. A tag containing same information shall be attached to the leading end of the cable. An arrow and suitable accompanying wording shall be marked on one end of the reel indicating the direction in which it should be rolled.</p>																																												
4.00.04.03	<p>The standard drum length for HT power cables with a maximum tolerance of +/- 5%, may be decided by the bidder subject to condition that there shall not be any joint in cable, where application length of cable is up to & including 1000 meter for single core cable, and 750 meter for multicore cable. The standard drum length of LT power cable with a maximum tolerance of +/- 5% may be decided by the bidder subject to condition that there shall not be any joint in cable, where application length of cable is up to & including 1000 meter for single core cable excluding 630 sqmm size, and 750 meter for multicore cable & single core 630 sqmm. The standard drum length for Control cables with a maximum tolerance of +/- 5% may be decided by the bidder subject to condition that there shall not be any joint in cable, where application length of cable is up to & including 1000 meter One drum length of each cable size can be of non-standard length(not less than 250 meter) so as to match the ordered quantity subject to condition that there shall not be any joint in cable.</p>																																												
5.00.00	TYPE, ROUTINE AND ACCEPTANCE TESTS																																												
5.01.00	Type Tests																																												
5.01.01	<p>The reports for the following type tests shall be submitted for one size each of LT XLPE, LT PVC Power and control cables. The following type tests shall be carried out on one size each of 19/33 KV & 11/11 KV, 3.3/3.3 KV HT Cables. Size shall be decided by the employer during detailed engineering</p> <table border="1" data-bbox="375 1045 1425 1843"> <thead> <tr> <th data-bbox="375 1045 516 1087">S. No</th> <th data-bbox="516 1045 987 1087">Type Test</th> <th data-bbox="987 1045 1425 1087">Remarks</th> </tr> </thead> <tbody> <tr> <td data-bbox="375 1087 516 1192">1.</td> <td data-bbox="516 1087 987 1192">Resistance test For Armour Wires / Formed Wires</td> <td data-bbox="987 1087 1425 1192"></td> </tr> <tr> <td data-bbox="375 1192 516 1234">2.</td> <td data-bbox="516 1192 987 1234">Measurement of Dimensions</td> <td data-bbox="987 1192 1425 1234"></td> </tr> <tr> <td data-bbox="375 1234 516 1276">3.</td> <td data-bbox="516 1234 987 1276">Tensile Test</td> <td data-bbox="987 1234 1425 1276"></td> </tr> <tr> <td data-bbox="375 1276 516 1318">4.</td> <td data-bbox="516 1276 987 1318">Elongation test</td> <td data-bbox="987 1276 1425 1318"></td> </tr> <tr> <td data-bbox="375 1318 516 1360">5.</td> <td data-bbox="516 1318 987 1360">Torsion test</td> <td data-bbox="987 1318 1425 1360">For round wires only</td> </tr> <tr> <td data-bbox="375 1360 516 1402">6.</td> <td data-bbox="516 1360 987 1402">Wrapping test</td> <td data-bbox="987 1360 1425 1402"></td> </tr> <tr> <td data-bbox="375 1402 516 1444">7.</td> <td data-bbox="516 1402 987 1444">Resistance test</td> <td data-bbox="987 1402 1425 1444"></td> </tr> <tr> <td data-bbox="375 1444 516 1528">8(a)</td> <td data-bbox="516 1444 987 1528">Mass & uniformity of Zinc Coating tests</td> <td data-bbox="987 1444 1425 1528">For GS wires/formed wires only.</td> </tr> <tr> <td data-bbox="375 1528 516 1612">8(b)</td> <td data-bbox="516 1528 987 1612">Adhesion test For XLPE insulation & PVC Sheath</td> <td data-bbox="987 1528 1425 1612">For GS wires/formed wires only</td> </tr> <tr> <td data-bbox="375 1612 516 1654">9.</td> <td data-bbox="516 1612 987 1654">Test for thickness</td> <td data-bbox="987 1612 1425 1654"></td> </tr> <tr> <td data-bbox="375 1654 516 1738">10.</td> <td data-bbox="516 1654 987 1738">Tensile strength and elongation test before ageing and after ageing</td> <td data-bbox="987 1654 1425 1738"></td> </tr> <tr> <td data-bbox="375 1738 516 1780">11.</td> <td data-bbox="516 1738 987 1780">Ageing in air oven</td> <td data-bbox="987 1738 1425 1780"></td> </tr> <tr> <td data-bbox="375 1780 516 1843">12.</td> <td data-bbox="516 1780 987 1843">Loss of mass test</td> <td data-bbox="987 1780 1425 1843">For PVC outer sheath only.</td> </tr> </tbody> </table>			S. No	Type Test	Remarks	1.	Resistance test For Armour Wires / Formed Wires		2.	Measurement of Dimensions		3.	Tensile Test		4.	Elongation test		5.	Torsion test	For round wires only	6.	Wrapping test		7.	Resistance test		8(a)	Mass & uniformity of Zinc Coating tests	For GS wires/formed wires only.	8(b)	Adhesion test For XLPE insulation & PVC Sheath	For GS wires/formed wires only	9.	Test for thickness		10.	Tensile strength and elongation test before ageing and after ageing		11.	Ageing in air oven		12.	Loss of mass test	For PVC outer sheath only.
S. No	Type Test	Remarks																																											
1.	Resistance test For Armour Wires / Formed Wires																																												
2.	Measurement of Dimensions																																												
3.	Tensile Test																																												
4.	Elongation test																																												
5.	Torsion test	For round wires only																																											
6.	Wrapping test																																												
7.	Resistance test																																												
8(a)	Mass & uniformity of Zinc Coating tests	For GS wires/formed wires only.																																											
8(b)	Adhesion test For XLPE insulation & PVC Sheath	For GS wires/formed wires only																																											
9.	Test for thickness																																												
10.	Tensile strength and elongation test before ageing and after ageing																																												
11.	Ageing in air oven																																												
12.	Loss of mass test	For PVC outer sheath only.																																											
<p>TALCHER THERMAL POWER PROJECT STAGE-III (2X660 MW) EPC PACKAGE</p>	<p>TECHNICAL SPECIFICATIONS SECTION VI, PART-B BID DOC. NO.:CS-4540-001A-2</p>	<p>SUB-SECTION-B-08 HT LT AND CONTROL CABLES</p>	<p>PAGE 5 OF 6</p>																																										

CLAUSE NO.	TECHNICAL REQUIREMENTS			
5.02.00	S. No 13. 14. 15. 16. 17. 18. 19. 20. 21. 22	Type Test Hot deformation test Heat shock test Shrinkage test Thermal stability test Hot set test Water absorption test Oxygen index test Smoke density test Acid gas generation test Flammability test as per IEC-332 Part-3 (Category -B)	Remarks For PVC outer sheath only. For PVC outer sheath only For PVC outer sheath only For XLPE insulation only For XLPE insulation only For PVC outer sheath only For PVC outer sheath only For PVC outer sheath only For completed cable only	
	The following type tests reports for HT Cables shall be submitted for each type (voltage grade) & size of the cable: S. No. Type Test For all cables 1. Insulation resistance test (Volume Resistivity method) 2. High voltage test For cables of 19/33kV, 11/11KV,3.3/3.3KV Grade only. 3. Partial discharge test 4. Bending test 5. Dielectric power factor test a) As a function of voltage b) As a function of temperature 6. Heating cycle test 7. Impulse withstand test Indicative list of tests/ checks, Routine and Acceptance tests shall be as per Quality Assurance & Inspection table of H.T. Cables enclosed.			
TALCHER THERMAL POWER PROJECT STAGE-III (2X660 MW) EPC PACKAGE	TECHNICAL SPECIFICATIONS SECTION VI, PART-B BID DOC. NO.:CS-4540-001A-2	SUB-SECTION-B-08 HT LT AND CONTROL CABLES	PAGE 6 OF 6	



SUB-SECTION-B – 10

CABLING EARTHING

TALCHER THERMAL POWER PROJECT STAGE-III (2X660 MW)
EPC PACKAGE
BID DOC NO.: CS-4540-001A-2

TECHNICAL SPECIFICATION
SECTION - VI
PART-B

CLAUSE NO.	TECHNICAL REQUIREMENTS	
<p>1.00.00</p> <p>1.01.00</p> <p>1.02.00</p>	<p>CODES AND STANDARDS</p> <p>All standards, specifications and codes of practice referred to herein shall be the latest editions including all applicable official amendments and revisions as on date of opening of bid. In case of conflict between this specification and those (IS codes, standards, etc.) referred to herein, the former shall prevail. All work shall be carried out as per the following standards/ codes as applicable .</p> <p>IS:513 Cold rolled low carbon steel sheets and strips. IS:802 Code of practice for the use of Structural Steel in Overhead Transmission Line Towers. IS:1079 Hot Rolled carbon steel sheet & strips IS:1239 Mild steel tubes, tubulars and other wrought steel fittings IS:1255 Code of practice for installation and maintenance of power cables upto and including 33 KV rating IS:1367 Part-13 Technical supply conditions for threaded Steel fasteners. (Hot dip galvanized coatings on threaded fasteners). IS:2147 Degree of protection provided by enclosures for low voltage switchgear and control gear IS:2309 Code of Practice for the protection of building and allied structures against lightning. IS:2629 Recommended practice for hot dip galvanising of iron & steel IS:2633 Method for testing uniformity of coating on zinc coated articles. IS:3043 Code of practice for Earthing IS:3063 Fasteners single coil rectangular section spring washers. IS:6745 Methods for determination of mass of zinc coating on zinc coated iron & steel articles. IS:8308 Compression type tubular in- line connectors for aluminium conductors of insulated cables IS:8309 Compression type tubular terminal ends for aluminium conductors of insulated cables. IS:9537 Conduits for electrical installation. IS:9595 Metal - arc welding of carbon and carbon manganese steels - recommendations. IS:13573 Joints and terminations for polymeric cables. BS:476 Fire tests on building materials and structures IEEE:80 IEEE guide for safety in AC substation grounding IEEE:142 Grounding of Industrial & commercial power systems DIN 46267 (Part-II) Non tension proof compression joints for Aluminium conductors. DIN 46329 Cable lugs for compression connections, ring type ,for Aluminium conductors BS:6121 Specification for mechanical Cable glands for elastomers and plastic insulated cables. Indian Electricity Act. Indian Electricity Rules.</p> <p>Equipment complying with other internationally accepted standards such as IEC, BS, DIN, USA, VDE, NEMA etc. will also be considered if they ensure performance and constructional features equivalent or superior to standards listed above. In such a case, the Bidder shall clearly indicate the standard(s) adopted, furnish a copy in English of the latest revision of the standards alongwith copies of all official amendments and revisions in force as on date of opening of bid and shall clearly bring out the salient features for comparison.</p>	
<p>TALCHER THERMAL POWER PROJECT STAGE-III (2X660 MW) EPC PACKAGE</p>	<p>TECHNICAL SPECIFICATION SECTION – VI, PART-B BID DOC NO : CS-4540-001A-2</p>	<p>SUB SECTION-B-10 CABLING, EARTHING & LIGHTNING PROTECTION</p> <p>Page 1 of 21</p>

CLAUSE NO.	TECHNICAL REQUIREMENTS	
2.01.11	<p>Conscious exceptions to the above guidelines may be accepted under special conditions but suitable measures should be taken at such location to:</p> <ul style="list-style-type: none"> • Meet all safety requirements • Safeguard against fire hazards, mechanical damage, flooding of water, oil accumulation, electrical faults/interferences, etc 	
3.00.00	EQUIPMENT DESCRIPTION	
3.01.00	Cable trays, Fittings & Accessories	
3.01.01	<p>Cable trays shall be ladder/perforated type as specified complete with matching fittings (like brackets, elbows, bends, reducers, tees, crosses, etc.) accessories (like side coupler plates, etc. and hardware (like bolts, nuts, washers, G.I. strap, hook etc.) as required. Cable tray shall be ladder type for power & control cables and perforated for instrumentation cables.</p>	
3.01.02	<p>Cable trays, fittings and accessories shall be fabricated out of rolled mild steel sheets free from flaws such as laminations, rolling marks, pitting etc. These (including hardware) shall be hot dip galvanized as per Clause No. 3.13.00 of this chapter.</p>	
3.01.03	<p>Cable trays shall have standard width of 150 mm, 300 mm & 600 mm and standard lengths of 2.5 metre. Thickness of mild steel sheets used for fabrication of cable trays and fittings shall be 2 mm. The thickness of side coupler plates shall be 3 mm.</p>	
3.01.04	<p>Cable troughs shall be required for branching out few cables from main cable route. These shall be U-shaped, fabricated of mild steel sheets of thickness 2 mm and shall be hot dip galvanized as per Clause No. 3.13.00 of this chapter. Troughs shall be standard width of 50 mm & 75 mm with depth of 25 mm.</p>	
3.01.05	<p>The tolerance for cable tray and accessories shall be as per IS 2102 (Part-1). Tolerance Class: - Coarse</p>	
3.02.00	Support System for Cable Trays	
3.02.01	<p>Cable tray support system shall be pre-fabricated out of single sheet as per enclosed tender drawings.</p>	
3.02.02	<p>Support system for cable trays shall essentially comprise of the two components i.e. main support channel and cantilever arms. The main support channel shall be of two types : (i) C1:- having provision of supporting cable trays on one side and (ii) C2:-having provision of supporting cable trays on both sides. The support system shall be the type described hereunder</p> <ol style="list-style-type: none"> a. Cable supporting steel work for cable racks/cables shall comprise of various channel sections, cantilever arms, various brackets, clamps, floor plates, all hardwares such as lock washers, hexagon nuts, hexagon head bolt, support hooks, stud nuts, hexagon head screw, channel nut, channel nut with springs, fixing studs, etc. b. The system shall be designed such that it allows easy assembly at site by using bolting. All cable supporting steel work, hardwares fittings and accessories shall be prefabricated factory galvanized. c. The main support and cantilever arms shall be fixed at site using necessary brackets, clamps, fittings, bolts, nuts and other hardware etc. to form various arrangements required to support the cable trays. Welding of the components shall not be allowed. However, welding of the bracket (to which the main support channel is bolted) to the overhead beams, structural steel, insert plates or reinforcement bars will be permitted. Any cutting or welding of the galvansied surface shall be brushed and red lead primer, oil primer & aluminium paint shall be applied 	
<p>TALCHER THERMAL POWER PROJECT STAGE-III (2X660 MW) EPC PACKAGE</p>	<p>TECHNICAL SPECIFICATION SECTION – VI, PART-B BID DOC NO : CS-4540-001A-2</p>	<p>SUB SECTION-B-10 CABLING, EARTHING & LIGHTNING PROTECTION</p> <p>Page 3 of 21</p>

CLAUSE NO.	TECHNICAL REQUIREMENTS	
	<p>d. All steel components, accessories, fittings and hardware shall be hot dip galvanised after completing welding, cutting, drilling and other machining operation.</p> <p>e. The typical arrangement of flexible support system is shown in the enclosed drawings and described briefly below: The main support channel and cantilever arms shall be fabricated out of 2.5 thick rolled steel sheet conforming to IS 1079.</p> <p>f. Cantilever arms of 320 mm, 620mm and 750 mm in length are required, and shall be as shown in the enclosed drawing. The arm portion shall be suitable for assembling the complete arm assembly on to component constructed of standard channel section. The back plate shall allow sufficient clearance for fixing bolt to be tightened with tray in position.</p> <p>g. Support system shall be able to withstand</p> <ul style="list-style-type: none"> • weight of the cable trays • weight of the cables (75 Kg/Metre run of each cable tray) • Concentrated load of 75 Kg between every support span. • Factor of safety of minimum 1.5 shall be considered. 	
3.02.03	The size of structural steel members or thickness of sheet steel of main support channel and cantilever arms and other accessories as indicated above or in the enclosed drawings are indicative only. Nevertheless, the support system shall be designed by the bidder to fully meet the requirements of type tests as specified. In case the system fails in the tests, the components design modification shall be done by the Bidder without any additional cost to the Employer. The bidder shall submit the detailed drawings of the system offered by him alongwith the bid.	
3.02.04	Four legged structure shall be provided wherever there is change in elevation and change in direction	

3.03.00	Pipes, Fittings & Accessories	
3.03.01	Pipes offered shall be complete with fittings and accessories (like tees, elbows, bends, check nuts, bushings, reducers, enlargers, coupling caps, nipples etc.) The size of the pipe shall be selected on the basis of maximum 40% fill criteria	
TALCHER THERMAL POWER PROJECT STAGE-III (2X660 MW) EPC PACKAGE	TECHNICAL SPECIFICATION SECTION – VI, PART-B BID DOC NO : CS-4540-001A-2	SUB SECTION-B-10 CABLING, EARTHING & LIGHTNING PROTECTION Page 4 of 21

CLAUSE NO.	TECHNICAL REQUIREMENTS	
3.03.02	GI Pipes shall be of medium duty as per IS: 1239	
3.03.03	Duct banks shall be High Density PE pipes encased in PCC (10% spare of each size, subject to minimum one) with suitable water-proof manholes.	
3.03.04	Hume pipes shall be NP3 type as per IS 458.	
3.03.05	TERNE Coated Flexible Steel Conduits shall be water proof and rust proof made of heat resistant lead coated steel. Conduit diameter shall be uniform throughout its length. Internal surface of the conduit shall be free from burrs and sharp edges. Conduits shall be complete with necessary accessories for proper termination of the conduit with junction boxes and lighting fixtures	
3.03.06	HDPE pipes and conduits shall be PE-80, PN-10 type as per IS 4984/IS 8008 part-I.	
3.04.00	Junction Boxes	
3.04.01	<p>Junction box shall be made of Fire retardant material. Material of JB shall be Thermoplastic or thermosetting or FRP type. The box shall be provided with the terminal blocks, mounting bracket and screws etc. The cable entry shall be through galvanized steel conduits of suitable diameter. The JB shall have suitable for installing glands of suitable size on the bottom of the box. The JB shall be suitable for surface mounting on ceiling/structures. The JB shall be of grey color RAL 7035. All the metal parts shall be corrosion protected. Junction box surface should be such that it is free from crazings, blisterings, wrinkling, colour blots/striations. There should not be any mending or repair of surface. JB's will be provided with captive screws so that screws don't fall off when cover is opened. JB's mounting brackets should be of powder coated MS. Type test reports for the following tests shall be furnished:-</p> <p>(a) Impact resistance for impact energy of 2 Joules (IK07) as per BS EN50102</p> <p>(b) Thermal ageing at 70deg C for 96 hours as per IEC60068-2-2Bb.</p> <p>(c) Class of protection shall be IP 55.</p> <p>(d) HV test.</p>	

TALCHER THERMAL POWER PROJECT STAGE-III (2X660 MW) EPC PACKAGE	TECHNICAL SPECIFICATION SECTION – VI, PART-B BID DOC NO : CS-4540-001A-2	SUB SECTION-B-10 CABLING, EARTHING & LIGHTNING PROTECTION	Page 5 of 21
--	--	---	-----------------

CLAUSE NO.	TECHNICAL REQUIREMENTS	
3.06.00 3.06.01	<p>Cable glands</p> <p>Cable shall be terminated using double compression type cable glands. Testing requirements of Cable glands shall conform to BS:6121 and gland shall be of robust construction capable of clamping cable and cable armour (for armoured cables) firmly without injury to insulation. Cable glands shall be made of heavy duty brass machine finished and nickel chrome plated. Thickness of plating shall not be less than 10 micron. All washers and hardware shall also be made of brass with nickel chrome plating Rubber components shall be of neoprene or better synthetic material and of tested quality. Cable glands shall be suitable for the sizes of cable supplied/erected.</p>	
3.07.00 3.07.01	<p>Cable lugs/ferrules</p> <p>Cable lugs/ferrules shall be solderless crimping type suitable for power and control cables as per the DIN 46239. Aluminium solderless crimping lugs/ ferrules shall be used for Aluminium cables and Copper lugs/ferrules shall be used for Copper cables. Bimetallic washers or bimetallic type lugs shall be used for bimetallic connections.</p> <p>Crimping tool for crimping (from 1.5sqmm cable to 630sqmm cables) above mentioned lugs shall be of Hexagonal Type crimp profile, with suitable die of crimp match code.</p> <p>Characteristics of crimping tool:</p> <ol style="list-style-type: none"> 1) To should generate enough pressure to pass pull out test as per IEC 61238-1. Relevant type test to be produced for the sizes specified in the tender. 2) Tool die shall be replaceable for assorted sizes and crimp code to be mentioned on both part the die. 3) Tool should be compliant of testing according to IEC, UL and GS standards. <p>Tool shall have features such as:</p> <ul style="list-style-type: none"> • Auto retraction system • Manual retraction stop. • Feedback signals for improper pressure • Better battery capacity and with status display • Flexible and rotating head for easy crimping. 	
3.08.00 3.08.01	<p>Trefoil clamps</p> <p>Trefoil clamps for single core cables shall be pressure die cast aluminum or fibre glass or nylon and shall include necessary fixing accessories like G.I. nuts, bolts, washers, etc. Trefoil clamps shall have adequate mechanical strength, when installed at 1 mtr intervals, to withstand the forces generated by the peak value of maximum system short circuit current.</p>	
3.09.00 3.09.01	<p>Cable Clamps & Ties</p> <p>The cable clamps/ties required to clamp multicore cables shall be of SS-316 material, 12mm wide, polyester coated ladder lock type. The clamps/ties shall have self locking arrangement</p>	

CLAUSE NO.	TECHNICAL REQUIREMENTS	
	<p>& shall have sufficient strength. The cable clamps/ties shall be supplied in finished individual pieces of suitable length to meet the site requirements.</p>	
3.10.00	<p>Receptacles</p>	
3.10.01	<p>Receptacles boxes shall be fabricated out of MS sheet of 2mm thickness and hot dipped gavanised or of die-cast aluminium alloy of thickness not less than 2.5 mm. The boxes shall be provided with two nos. earthing terminals, gasket to achieve IP55 degree of protection, terminal blocks for loop-in loop-out for cable of specified sizes, mounting brackets suitable for surface mounting on wall/column/structure, gland plate etc. The ON-OFF switch shall be rotary type heavy duty, double break,AC23 category, suitable for AC supply. Plug and Socket shall be shrouded Die-cast aluminium. Socket shall be provided with lid safety cover. Robust mechanical interlock shall be provided such that the switch can be put ON only when the plug is fully engaged and plug can be withdrawn only when the switch is in OFF position. Also cover can be opened only when the switch is in OFF position. Wiring shall be carried out with 1100 V grade PVC insulated stranded aluminium/copper wire of adequate size. The Terminal blocks shall be of 1100 V grade. The Terminal blocks shall be of 1100 V grade made up of unbreakable polyimide 6.6 grade with adequate current rating and size. The welding receptacles shall be provided with RCCB/RCD of 30mA sensitivity having facility for manual testing/checking of operation of RCCB/RCD. Location and Minimum no of RC type receptacle TG and SG area shall be provided as per Annex-I attached.</p>	
3.11.00	<p>Cable Drum Lifting Jack</p> <p>The jack for cable drum lifting shall be of screw type with 10 ton capacity. The cable drum jacks shall be manufactured from fabricated steel. The spindles supplied with the cable drum jack shall be manufactured using BSEN-24 grade steel bar with locking collars. Jack nests shall be of SG cast steel. Cable drum jack supplied shall have undergone load testing and reports for the same shall be submitted. At least Two Nos. of jacks shall be supplied for NTPC use. Contractor has to make arrangements for his own jacks for cable reeling/unreeling under his scope of installation.</p>	
3.12.00	<p>Galvanising</p>	
3.12.01	<p>Galvanising of steel components and accessories shall conform to IS:2629 , IS4759 & IS:2633. Additionally galvanising shall be uniform, clean smooth, continuous and free from acid spots.</p>	
3.12.02	<p>The amount of zinc deposit over threaded portion of bolts, nuts, screws and washers shall be as per IS:1367 . The removal of extra zinc on threaded portion of components shall be carefully done to ensure that the threads shall have the required zinc coating on them as specified</p>	
3.13.00	<p>Welding</p>	
3.13.01	<p>The welding shall be carried out in accordance with IS:9595. All welding procedures and welders qualification shall also be followed strictly in line with IS:9595</p>	
4.00.00	<p>INSTALLATION</p>	
4.01.00	<p>Cable tray and Support System Installation</p>	
4.01.01	<p>Cables shall run in cable trays mounted horizontally or vertically on cable tray support system which in turn shall be supported from floor, ceiling, overhead structures, trestles, pipe racks, trenches or other building structures.</p>	
4.01.02	<p>Horizontally running cable trays shall be clamped by bolting to cantilever arms and vertically running cable trays shall be bolted to main support channel by suitable bracket/clamps on both top and bottom side rails at an interval of 2000 mm in general. For vertical cable risers/shafts cable trays shall be supported at an interval of 1000mm in general. Fixing of cable trays to cantilever arms or main support channel by welding shall not be accepted.</p>	
<p>TALCHER THERMAL POWER PROJECT STAGE-III (2X660 MW) EPC PACKAGE</p>	<p>TECHNICAL SPECIFICATION SECTION – VI, PART-B BID DOC NO : CS-4540-001A-2</p>	<p>SUB SECTION-B-10 CABLING, EARTHING & LIGHTNING PROTECTION</p> <p>Page 7 of 21</p>

CLAUSE NO.	TECHNICAL REQUIREMENTS											
	<p>Cable tray installation shall generally be carried out as per the approved guidelines/ drawings. Vendor shall design the support system along with tray, spacing etc in line with tray loadings/drawings.</p> <p>4.01.03 The cantilever arms shall be positioned on the main support channel with a minimum vertical spacing of 300 mm unless otherwise indicated.</p> <p>4.01.04 The contractor shall fix the brackets/ clamps/ insert plates using anchor fasteners. Minimum size of anchor fasteners shall be M 8 X 50 and material shall be stainless steel grade 316 or better. Anchor fastener shall be fixed as recommended by manufacturer and as approved by site engineer. For brick wall suitable anchor fasteners shall be used as per the recommendations of manufacturer. Make of anchor fasteners subject to QA approval and the same shall be finalized at pre-award stage.</p> <p>4.01.05 All cable way sections shall have identification, designations as per cable way layout drawings and painted/stenciled at each end of cable way and where there is a branch connection to another cable way. Minimum height of letter shall be not less than 75 mm. For long lengths of trays, the identification shall be painted at every 10 meter. Risers shall additionally be painted/stenciled with identification numbers at every floor.</p> <p>4.01.06 In certain cases it may be necessary to site fabricate portions of trays, supports and other non standard bends where the normal prefabricated trays, supports and accessories may not be suitable. Fabricated sections of trays, supports and accessories to make the installation complete at site shall be neat in appearance and shall match with the prefabricated sections in the dimensions. They shall be applied with one coat of red lead primer, one coat of oil primer followed by two finishing coats of aluminium paint.</p> <p>4.01.07 In fire prone areas, like Boiler, TG, fuel oil area and any other strategic location etc, fire retardant paint to be applied after installation cables.</p> <p>4.02.00 Conduits/Pipes/Ducts Installation</p> <p>4.02.01 The Contractor shall ensure for properly embedding conduit pipe sleeves wherever necessary for cabling work. All openings in the floor/roof/wall / cable tunnel/cable trenches made for conduit installation shall be sealed and made water proof by the Contractor.</p> <p>4.02.02 GI pull wire of adequate size shall be laid in all conduits before installation. Metallic conduit runs at termination shall have two lock nuts wherever required for junction boxes etc.</p> <p>4.02.03 Conduit runs/sleeves shall be provided with PVC bushings having round edge at each end. All conduits/pipes shall have their ends closed by caps until cables are pulled. After cables are pulled, the ends of conduits/pipes shall be sealed with Glass wool/Cement Mortar/Putty to prevent entrance of moisture and foreign material</p> <p>4.02.04 Exposed conduit/pipe shall be adequately supported by racks, clamps, straps or by other approved means. Conduits /pipe support shall be installed square and true to line and grade with an average spacing between the supports as given below, unless specified otherwise</p> <table border="0" data-bbox="402 1539 950 1682"> <thead> <tr> <th>Conduit /pipe size (dia).</th> <th>Spacing</th> </tr> </thead> <tbody> <tr> <td>Upto 40 mm</td> <td>1 M</td> </tr> <tr> <td>50 mm</td> <td>2.0 M</td> </tr> <tr> <td>65-85 mm</td> <td>2.5 M</td> </tr> <tr> <td>100 mm and above</td> <td>3.0 M</td> </tr> </tbody> </table> <p>4.02.05 For bending of conduits, bending machine shall be arranged at site by the contractor to facilitate cold bending. The bends formed shall be smooth.</p>	Conduit /pipe size (dia).	Spacing	Upto 40 mm	1 M	50 mm	2.0 M	65-85 mm	2.5 M	100 mm and above	3.0 M	
Conduit /pipe size (dia).	Spacing											
Upto 40 mm	1 M											
50 mm	2.0 M											
65-85 mm	2.5 M											
100 mm and above	3.0 M											
<p>TALCHER THERMAL POWER PROJECT STAGE-III (2X660 MW) EPC PACKAGE</p>	<p>TECHNICAL SPECIFICATION SECTION – VI, PART-B BID DOC NO : CS-4540-001A-2</p>	<p>SUB SECTION-B-10 CABLING, EARTHING & LIGHTNING PROTECTION</p> <p>Page 8 of 21</p>										

CLAUSE NO.	TECHNICAL REQUIREMENTS	
4.03.00	Junction Boxes Installation	
4.03.01	Junction boxes shall be mounted at a height of 1200mm above floor level or as specified in the drawings and shall be adequately supported/mounted on masonry wall by means of anchor fasteners/ expandable bolts or shall be mounted on an angle, plate or other structural supports fixed to floor, wall, ceiling or equipment foundations.	
4.04.00	Cable Installation	
4.04.01	Cable installation shall be carried out as per IS:1255 and other applicable standards.	
4.04.02	For Cable unloading, pulling etc following guidelines shall be followed in general:	
	<p>a) Cable drums shall be unloaded, handled and stored in an approved manner on hard and well drained surface so that they may not sink. In no case shall be drum be stored flat i.e. with flange horizontal. Rolling of drums shall be avoided as far as possible. For short distances, the drums may be rolled provided they are rolled slowly and in proper direction as marked on the drum. In absence of any indication, the drums may be rolled in the same direction as it was rolled during taking up the cables. For unreeling the cable, the drum shall be mounted on suitable jacks or on cable wheels and shall be rolled slowly so that cable comes out over the drum and not from below. All possible care shall be taken during unreeling and laying to avoid damage due to twist, kink or sharp bends. Cable ends shall be provided with sealed plastic caps to prevent damage and ingress of moisture.</p> <p>b) While laying cable, ground rollers shall be used at every 2 meter interval to avoid cable touching ground. The cables shall be pushed over the rollers by a gang of people positioned in between the rollers. Cables shall not be pulled from the end without having intermediate pushing arrangements. Pulling tension shall not exceed the values recommended by cable manufacturer. Selection of cable drums for each run shall be so planned so as to avoid using straight through joints. Care should be taken while laying the cables so as to avoid damage to cables. If any particular cable is damaged, the same shall be repaired or changed to the satisfaction of Project Manager.</p>	
4.04.03	Cables shall be laid on cable trays strictly in line with cable schedule	
4.04.04	Power and control cables shall be laid on separate tiers inline with the approved guidelines/drawings. The laying of different voltage grade cables shall be on different tiers according to the voltage grade of the cables. In horizontal tray stacks, H.T. cables shall be laid on top most tier and cables of subsequent lower voltage grades on lower tiers of trays. Single core cable in trefoil formation shall be laid with a distance of four times the diameter of cable between trefoil center lines and clamped at every one metre. All multicore cables shall be laid in touching formation. Power and control cables shall be secured fixed to trays/support with cable clamps/ties with self locking arrangement. For horizontal trays arrangements, multicore power cables and control cables shall be secured at every five meter interval. For vertical tray arrangement, individual multicore power cables and control cables shall be secured at every one meter. After completion of cable laying work in the particular vertical tray, all the control cables shall be binded to trays/supports by cable clamps/ties with self locking arrangement at every five meter interval and at every bend. Fibre Optical cable shall be laid in trenches/trays or as decided by Employer.	
4.04.05	Bending radii for cables shall be as per manufacturer's recommendations and IS:1255.	
4.04.06	Where cables cross roads/rail tracks, the cables shall be laid in hume pipe/ HDPE pipe.	
4.04.07	No joints shall be allowed in trip circuits, protection circuits and CT/PT circuits. Also joints in critical equipment in main plant area shall not be permitted. Vendor shall identify and accordingly procure the cable drum length.	
TALCHER THERMAL POWER PROJECT STAGE-III (2X660 MW) EPC PACKAGE	TECHNICAL SPECIFICATION SECTION – VI, PART-B BID DOC NO : CS-4540-001A-2	SUB SECTION-B-10 CABLING, EARTHING & LIGHTNING PROTECTION Page 9 of 21

CLAUSE NO.	TECHNICAL REQUIREMENTS											
4.04.08	In each cable run some extra length shall be kept at suitable point to enable one LT/two HT straight through joints to made, should the cable develop fault at a later stage. Control cable termination inside equipment enclosure shall have sufficient lengths so that shifting of termination in terminal blocks can be done without requiring any splicing.											
4.04.09	Wherever few cables are branching out from main trunk route troughs shall be used.											
4.04.10	Wind loading shall be considered for designing support as well Cable trays wherever required.											
4.04.11	Where there is a considerable risk of steam, hot oil or mechanical damage cable routes shall be protected by barriers or enclosures.											
4.04.12	The installation work shall be carried out in a neat workman like manner & areas of work shall be cleaned of all scraps, water, etc. after the completion of work in each area every day. Contractor shall replace RCC/Steel trench covers after the Installation work in that particular area is completed or when further work is not likely to be taken up for some time.											
4.04.13	<p>Separation At least 300mm clearance shall be provided between:</p> <ul style="list-style-type: none"> - HT power & LT power cables, - LT power & LT control/instrumentation cables, 											
4.04.14	<p>Segregation</p> <ol style="list-style-type: none"> 1) Segregation means physical isolation to prevent fire jumping. 2) All cables associated with the unit shall be segregated from cables of other units. 3) Interplant cables of station auxiliaries and unit critical drives shall be segregated in such a way that not more than half of the drives are lost in case of single incident of fire. Power and control cables for AC drives and corresponding emergency AC or DC drives shall be laid in segregated routes. Cable routes for one set of auxiliaries of same unit shall be segregated from the other set. 4) In switchyard, control cables of each bay shall be laid on separate racks/trays. 											
4.04.15	<p>Minimum number of spare cores required to be left for interconnection in control cables shall be as follows:</p> <table border="0" style="margin-left: 40px;"> <tr> <td style="text-align: center;">No. of cores in cable</td> <td style="text-align: center;">No. of spare cores</td> </tr> <tr> <td style="text-align: center;">2C,3C</td> <td style="text-align: center;">NIL</td> </tr> <tr> <td style="text-align: center;">5C</td> <td style="text-align: center;">1</td> </tr> <tr> <td style="text-align: center;">7C-10C</td> <td style="text-align: center;">2</td> </tr> <tr> <td style="text-align: center;">14C and above</td> <td style="text-align: center;">3</td> </tr> </table> <p>Minimum number of spare cores required to be left for interconnection in control cables shall be as follows:</p>	No. of cores in cable	No. of spare cores	2C,3C	NIL	5C	1	7C-10C	2	14C and above	3	
No. of cores in cable	No. of spare cores											
2C,3C	NIL											
5C	1											
7C-10C	2											
14C and above	3											

CLAUSE NO.	TECHNICAL REQUIREMENTS		
4.04.17	Cable tags shall be provided on all cables at each end (just before entering the equipment enclosure), on both sides of a wall or floor crossing, on each duct/conduit entry, and at every 20 meters in cable tray/trench runs. Cable tags shall also be provided inside the switchgear, motor control centers, control and relay panels etc. where a number of cables enter together through a gland plate. Cable tag shall be of rectangular shape for power cables and control cables. Cable tag shall be of 2 mm thick aluminum with number punched on it and securely attached to the cable by not less than two turns of 20 SWG GI wire conforming to IS:280. Alternatively, the Contractor may also provide cable tags made of nylon, cable marking ties with cable number heat stamped on the cable tags. The cable tag requirements mentioned above shall prevail over Tag requirements mentioned elsewhere in this document for HT power, LT power & control cables.		
4.04.18	While crossing the floors, unarmoured cables shall be protected in conduits upto a height of 500 mm from floor level if not laid in tray.		
4.05.00	Cable Terminations & Connections		
4.05.01	The termination and connection of cables shall be done strictly in accordance with cable termination kit manufacturer" instructions, drawings and/or as directed by Project Manager. Cable jointer shall be qualified to carryout satisfactory cable jointing/termination. Contractor shall furnish for review documentary evidence/experience reports of the jointers to be deployed at site.		
4.05.02	Work shall include all clamps, fittings etc. and clamping, fitting, fixing, plumbing, soldering, drilling, cutting, taping, preparation of cable end, crimping of lug, insulated sleeving over control cable lugs, heat shrinking (where applicable), connecting to cable terminal, shorting and grounding as required to complete the job to the satisfaction of the Project Manager.		
4.05.03	The equipment will be generally provided with undrilled gland plates for cables/conduit entry. The Contractor shall be responsible for punching of gland plates, painting and touching up. Holes shall not be made by gas cutting. The holes shall be true in shape. All cable entry points shall be sealed and made vermin and dust proof. Unused openings shall be effectively sealed by 2mm thick aluminium sheets.		
4.05.04	Control cable cores entering control panel/switchgear/MCC/miscellaneous panels shall be neatly bunched, clamped and tied with self locking type nylon cable ties with de interlocking facility to keep them in position.		
4.05.05	All the cores of the control cable to be terminated shall have identification by providing ferrules at either end of the core, each ferrule shall be indelible, printed single tube ferrule and shall include the complete wire number and TB number as per the drawings. The ferrule shall fit tightly on the core. Spare cores shall have similar ferrules with suffix sp1, sp2, ---etc along with cable numbers and coiled up after end sealing.		
4.05.06	All cable terminations shall be appropriately tightened to ensure secure and reliable connections.		
5.00.00	EARTHING SYSTEM		
5.01.00	Earthing system shall be in strict accordance with IS:3043 and Indian Electricity Rules/Acts		
TALCHER THERMAL POWER PROJECT	TECHNICAL SPECIFICATION	SUB SECTION-B-10	Page
STAGE-III (2X660 MW)	SECTION – VI, PART-B	CABLING, EARTHING &	11 of 21
EPC PACKAGE	BID DOC NO : CS-4540-001A-2	LIGHTNING PROTECTION	

CLAUSE NO.	TECHNICAL REQUIREMENTS																																					
	<p>The earthing system shall be designed for a life expectancy of at least forty (40) years, for a system fault current of 63 kA for 1.0 sec. The minimum rate of corrosion of steel for selection of earthing conductor shall be 0.12mm per year.</p> <p>Earthing system network/earthmat shall be interconnected mesh of mild steel rods buried in ground in the plant. All areas under contractor scope of supply shall be interconnected together by minimum two parallel conductors. The Contractor shall furnish the detailed design and calculations for Employer's approval. Contractor shall obtain all necessary statutory approvals for the system. All the columns shall be earthed by nearby risers and earthmat grid spacing shall be maximum 10 mts. Minimum two nos of risers shall be provided for each equipment in SG area. Separate dedicated riser shall be provided for C&I earthing purpose and also for Lightning down conductor connection purpose. Sufficient nos of risers near the equipment shall be provided as per the system requirement. Ring type earthing around the offsite building shall be provided with interconnection of with main grid at minimum two points.</p>																																					
5.02.00	The earth conductors shall be free from pitting, laminations, rust, scale and other electrical, mechanical defects																																					
5.04.00	<p>The sizes of earthing conductors for various electrical equipments shall be as below:</p> <table border="1" data-bbox="397 1060 1347 1722"> <thead> <tr> <th>Equipment</th> <th>Earth conductor buried in earth</th> <th>Earth conductor above ground level & in built-up trenches</th> </tr> </thead> <tbody> <tr> <td>a) Main earth grid</td> <td>Min 40 mm dia. MS rod or as per actual calculation whichever is more</td> <td>65 x 8mm GS flat</td> </tr> <tr> <td>b) 33kV/11kV/6.6kV/3.3 kV/ switchgear equipment and 415V switchgear</td> <td>---</td> <td>65 x 8mm GS flat</td> </tr> <tr> <td>c) 415 V MCC/ Distribution boards / Transformers</td> <td>---</td> <td>50 x 6mm GS flat</td> </tr> <tr> <td>d) LT Motors above 125 KW</td> <td>---</td> <td>50 x 6mm GS flat</td> </tr> <tr> <td>25 KW to 125 KW</td> <td>---</td> <td>25 x 6mm GS flat</td> </tr> <tr> <td>1KW to 25 KW</td> <td>---</td> <td>25 x 3mm GS flat</td> </tr> <tr> <td>Fractional House power motor</td> <td>---</td> <td>8 SWG GS wire</td> </tr> <tr> <td>e) Control panel & control desk</td> <td>---</td> <td>25 x 3 mm GS flat</td> </tr> <tr> <td>f) Push button station / Junction Box</td> <td>---</td> <td>8 SWG GI wire</td> </tr> <tr> <td>g) Columns, structures, cable trays and bus ducts enclosures</td> <td>---</td> <td>50 x 6mm GS flat</td> </tr> <tr> <td>h) Crane, rails, rail tracks & other non-current carrying metal parts</td> <td>---</td> <td>25 x 6mm GS flat</td> </tr> </tbody> </table>	Equipment	Earth conductor buried in earth	Earth conductor above ground level & in built-up trenches	a) Main earth grid	Min 40 mm dia. MS rod or as per actual calculation whichever is more	65 x 8mm GS flat	b) 33kV/11kV/6.6kV/3.3 kV/ switchgear equipment and 415V switchgear	---	65 x 8mm GS flat	c) 415 V MCC/ Distribution boards / Transformers	---	50 x 6mm GS flat	d) LT Motors above 125 KW	---	50 x 6mm GS flat	25 KW to 125 KW	---	25 x 6mm GS flat	1KW to 25 KW	---	25 x 3mm GS flat	Fractional House power motor	---	8 SWG GS wire	e) Control panel & control desk	---	25 x 3 mm GS flat	f) Push button station / Junction Box	---	8 SWG GI wire	g) Columns, structures, cable trays and bus ducts enclosures	---	50 x 6mm GS flat	h) Crane, rails, rail tracks & other non-current carrying metal parts	---	25 x 6mm GS flat	
Equipment	Earth conductor buried in earth	Earth conductor above ground level & in built-up trenches																																				
a) Main earth grid	Min 40 mm dia. MS rod or as per actual calculation whichever is more	65 x 8mm GS flat																																				
b) 33kV/11kV/6.6kV/3.3 kV/ switchgear equipment and 415V switchgear	---	65 x 8mm GS flat																																				
c) 415 V MCC/ Distribution boards / Transformers	---	50 x 6mm GS flat																																				
d) LT Motors above 125 KW	---	50 x 6mm GS flat																																				
25 KW to 125 KW	---	25 x 6mm GS flat																																				
1KW to 25 KW	---	25 x 3mm GS flat																																				
Fractional House power motor	---	8 SWG GS wire																																				
e) Control panel & control desk	---	25 x 3 mm GS flat																																				
f) Push button station / Junction Box	---	8 SWG GI wire																																				
g) Columns, structures, cable trays and bus ducts enclosures	---	50 x 6mm GS flat																																				
h) Crane, rails, rail tracks & other non-current carrying metal parts	---	25 x 6mm GS flat																																				
5.05.00	Metallic frame of all electrical equipment shall be earthed by two separate and distinct connections to earthing system, each of 100% capacity, Crane rails, tracks, metal pipes and conduits shall also be effectively earthed at two points. Steel RCC columns, metallic stairs,																																					

CLAUSE NO.	TECHNICAL REQUIREMENTS	
	<p>and rails etc. of the building housing electrical equipment shall be connected to the nearby earthing grid conductor by one earthing ensured by bonding the different sections of hand rails and metallic stairs. Metallic sheaths/screens, and armour of multi-core cables shall be earthed at both ends. Metallic Sheaths and armour of single core cables shall be earthed at switchgear end only unless otherwise approved. Every alternate post of the switchyard fence shall be connected to earthing grid by one GS flat and gates by flexible lead to the earthed post. Railway tracks within the plant area shall be bonded across fish plates and connected to earthing grid at several locations. Portable tools, appliances and welding equipment shall be earthed by flexible insulated cable.</p>	
5.06.00	<p>Each continuous laid lengths of cable tray shall be earthed at minimum two places by G.S. flats to earthing system, the distance between earthing points shall not exceed 30 meter. Wherever earth mat is not available, necessary connections shall be done by driving an earth electrode in the ground</p>	
5.09.00	<p>Connections between earth leads and equipment shall normally be of bolted type. Contact surfaces shall be thoroughly cleaned before connections. Equipment bolted connections after being tested and checked shall be painted with anti corrosive paint/compound.</p>	
5.10.00	<p>Suitable earth risers as approved shall be provided above finished floor/ground level, if the equipment is not available at the time of laying of main earth conductor.</p>	
5.11.00	<p>Connections between equipment earthing leads and between main earthing conductors shall be of welded type. For rust protection the welds should be treated with red lead compound and afterwards thickly coated with bitumen compound. All welded connections shall be made by electric arc welding.</p>	
5.12.00	<p>Resistance of the joint shall not be more than the resistance of the equivalent length of conductors.</p>	
5.13.00	<p>Earthing conductors buried in ground shall be laid minimum 600 mm below grade level unless otherwise indicated in the drawing. Back filling material to be placed over buried conductors shall be free from stones and harmful mixtures. Back filling shall be placed in layers of 150 mm.</p>	
5.14.00	<p>Earthing conductors embedded in the concrete floor of the building shall have approximately 50 mm concrete cover.</p>	
5.15.00	<p>A minimum earth coverage of 300 mm shall be provided between earth conductor and the bottom of trench/foundation/underground pipes at crossings. Earthing conductors crossings the road can be installed in pipes. Wherever earthing conductor crosses or runs at less than 300 mm distance along metallic structures such as gas, water, steam pipe lines, steel reinforcement in concrete, it shall be bonded to the same.</p>	
5.16.00	<p>Earthing conductors along their run on columns, walls, etc. shall be supported by suitable welding / cleating at interval of 1000mm and 750mm respectively.</p>	

<p>TALCHER THERMAL POWER PROJECT STAGE-III (2X660 MW) EPC PACKAGE</p>	<p>TECHNICAL SPECIFICATION SECTION – VI, PART-B BID DOC NO : CS-4540-001A-2</p>	<p>SUB SECTION-B-10 CABLING, EARTHING & LIGHTNING PROTECTION</p>	<p>Page 13 of 21</p>
---	---	--	--------------------------

CLAUSE NO.	Bidder's Name	
	DE-1B	LT MOTORS
	A.	GENERAL
5.	Manufacturer & Country of origin. (Shall be as per approved QA make)	
6.	Equipment driven by motor	
7.	Motor type	
8.	Quantity	
	B.	DESIGN AND PERFORMANCE DATA
18.	Frame size	
19.	Type of duty	
20.	Type of enclosure /Method of cooling/ Degree of	
21.	Applicable standard to which motor generally	
22.	Efficiency class as per IS 12615	
23.	(a)Whether motor is flame proof	Yes/No
	(b)If yes, the gas group to which it conforms as per IS:2148	
24.	Type of mounting	
25.	Direction of rotation as viewed from DE END	
26.	Standard continuous rating at 40 deg.C. ambient temp. as per Indian Standard (KW)	
27.	Derated rating for specified normal condition i.e. 50 deg. C ambient temperature (KW)	
28.	Maximum continuous load demand of driven	
29.	Rated Voltage (volts)	
30.	Permissible variation of :	
	a. Voltage (Volts)	
	b. Frequency (Hz)	
	c. Combined voltage and frequency	
31.	Rated speed at rated voltage and	
32.	At rated Voltage and frequency:	
	a. Full load current	

CLAUSE NO.	Bidder's Name		
	b. No load current		
33.	Power Factor at		
	a. 100% load		
	b. NO load		
	c. Starting.		
34.	Efficiency at rated voltage and frequency,		
	a. 100% load		
	b. 75% load		
	c. 50% load		
35.	Starting current (amps) at		
	a. 100 % voltage		
	b. 85% voltage		
	c. 80% voltage		
36.	Minimum permissible starting Voltage (Volts)		
37.	Starting time with minimum permissible voltage		
	a. Without driven equipment coupled		
	b. With driven equipment coupled		
38.	Safe stall time with 100% and 110% of rated		
	a. From hot condition		
	b. From cold condition		
39.	Torques :		
	a. Starting torque at min. permissible voltage(kg-		
	b. Pull up torque at rated voltage.		
	c. Pull out torque		
	d. Min accelerating torque (kg.m) available		
	e. Rated torque (kg.m)		
40.	Stator winding resistance per phase (ohms at 20		
41.	GD2 value of motors		

CLAUSE NO.	Bidder's Name		
	42.	No of permissible successive starts when motor is in hot condition	
	43.	Locked Rotor KVA Input	
	44.	Locked Rotor KVA/KW	
	45.	Vibration limit :Velocity (mm/s)	
	46.	Noise level limit (dBA)	
	C.	CONSTRUCTIONAL FEATURES	
	1.	Stator winding insulation	
		a. Class & Type	
		b. Winding Insulation Process	
		c. Tropicalised (Yes/No)	
		d. Temperature rise over specified maximum ambient temperature of 50 deg C	
		e. Method of temperature measurement	
		f. Stator winding connection	
	2.	Main Terminal Box	
		a. Type	
		b. Location(viewed from NDE side)	
		c. Entry of cables(bottom/side)	
		d. Recommended cable size(To be matched with cable size envisaged by owner)	
		e. Fault level (MVA),Fault level duration(sec)	
		f. Cable glands & lugs details (shall be suitable for	
	3.	Type of DE/NDE Bearing	
	4.	Motor Paint shade	
	5.	Weight of	
		a. Motor stator (KG)	
		b. Motor Rotor (KG)	
		c. Total weight (KG)	

CLAUSE NO.	Bidder's Name		
	D.	List of accessories.	
	1.	3 Space Heaters (Applicable for 30 KW & above motor) (Nos./Power in watts/supply voltage)	
	2.	Terminal Box for Space Heater (Yes/No)	
	3.	Speed switch (Yes/No)	
	4.	Insulation of bearing (Yes/No)	
	5.	Noise reducer(Yes/No)	
	6.	Grounding pads	
		i) No and size on motor body	
		ii) Nos on terminal Box	
	7.	Vibration pads	
		i) Nos and size	
		ii) Location	
	8.	Any other fitments	
	E.	List of curves.	
	1.	Torque speed characteristic of the motor	
	2.	Thermal withstand characteristic	
	3.	Starting. current Vs. Time	
	4.	Starting. current Vs speed	
	5.	P.F. and Effi. Vs Load	
	F.	Additional Data to be filled for each rating of DC Motor	
	1.	Rated armature voltage (Volt)	
	2.	Rated field excitation (Amp)	
	3.	Permissible % variation in voltage	
	4.	Minimum Permissible Starting voltage (volt)	
	5.	At rated voltage	
		i)Full load Armature current.(Amp)	

CLAUSE NO.	Bidder's Name	
	ii) Full load Field current (Amp)	
	iii) No load Armature current (Amp)	
6.	Full load Field current (Amp)	
7.	No load Armature current (Amp)	
8.	Minimum permissible field current (Amp) to avoid	
	i) Maximum permissible voltage	
	ii) Rated voltage	
	iii) Minimum Permissible Voltage	
9.	Resistance (indicative Values) in ohm	
	i) Armature winding (Arm + IP + Series) at 25	
	ii) Field Winding at 25 deg. C	
10..	Inductance (indicative values)	
	i) Armature winding	
	ii) Field winding	
11	Value of trimmer resistance (ohm) to be connected in series with the shunt field to	
	i) 220 V DC	
	ii) 250 V DC	
	iii) 187 V DC	
12	Value of the external resistance (ohm) required to be connected in series with armature during starting only	
13	Technical data sheet for external resistance box	
14	GA drawing of motor	
15	Starting time calculation	
16	Starter resistance design calculation	
17	Electrical connection diagram of motor	

	2X660MW TALCHER TPP EPC PACKAGE TECHNICAL SPECIFICATION FOR CABLE TRAYS & ACCESSORIES	SPECIFICATION NO. PE-TS-497-507-E021	
		VOLUME II B	
		SECTION D	
		REVISION 0	DATE: 23.12.2022
		SHEET	1 of 2

DATASHEET-A

1.0 APPLICABLE STANDARDS

- | | | |
|----|----------|--|
| a) | IS: 1079 | For hot rolled carbon steel sheet and strip. |
| b) | IS: 1730 | For dimensions for steel sheet and strip. |
| c) | IS: 1363 | Hexagon head bolts, screws and nuts. |
| d) | IS: 2629 | For hot dip galvanising of steel & surface pre treatment. |
| e) | IS: 2633 | For testing of zinc coating. |
| f) | IS: 6745 | For determining of mass of zinc coating. |
| g) | IS: 1367 | Galvanised Coating on threaded Fasteners.
(Part-XIII) |
| h) | IS: 1852 | For Rolling and Cutting Tolerances of hot rolled steel products. |
| i) | IS: 9595 | For thickness of welding of carbon & carbon manganese steels |

2.0 CABLE TRAYS & ACCESSORIES

- | | | | |
|-----|---|---|---|
| 2.1 | Material | : | Hot Rolled Mild Steel |
| 2.2 | Type | : | Ladder Type
Perforated Type
Cable trough |
| 2.3 | Standard Length of
Straight Length of
Cable Trays | : | 2.5 meters |
| 2.4 | Standard Width (mm) | : | Cable Trays: 600 300 150
Cable Trough: 75 50 |
| 2.5 | Construction | : | Conforming to enclosed drawing [PE-DG-405-507-E005] |
| 2.6 | Bending Radius
of Accessories (in mm) | : | 600 mm |
| 2.7 | Tolerance in length/width
/ height | : | + /- 2 mm |

3.0 FITTINGS

- | | | |
|-----------------|---|--|
| End connections | : | Through Coupler plates
(Side Coupler Plates shall be provided as part of cable tray & accessories supply with bolts, nuts, washers etc) |
|-----------------|---|--|

4.0 SHEET THICKNESS

- | | | |
|-------------------------------------|---|--|
| a) For cable trays &
Accessories | : | min 2.0 mm |
| b) For Coupler plate | : | min 3.0 mm |
| c) Tolerance in Thickness | : | (+ 0.2 mm)
(NO NEGATIVE TOLERANCE IS PERMITTED) |

	2X660MW TALCHER TPP EPC PACKAGE TECHNICAL SPECIFICATION FOR CABLE TRAYS & ACCESSORIES	SPECIFICATION NO. PE-TS-497-507-E021	
		VOLUME II B	
		SECTION D	
		REVISION 0	DATE: 23.12.2022
		SHEET	2 of 2

6.0 SURFACE TREATMENT

- a) Pre-treatment : IS 2629 before galvanisation
- b) Type : Hot dip galvanisation
- c) Applicable Standard : IS 2629
- d) Minimum thickness : 75 microns (minimum)
- e) Min. weight of Zinc deposit : 610 grams per square meter
- f) Tests for galvanizing : (i) Weight of Zinc Coating as per IS 6745.
(ii) Thickness of Zinc Coating as per IS 4759.
(iii) Uniformity of Zinc Coating as per IS 2633.
(iv) Adhesion Test as per IS 2629.

7.0 NUMBER OF COUPLER PLATES, BOLTS, WASHERS & NUTS REQUIRED FOR EACH CABLE TRAY SECTION (2.5 MTRS)

Sl. No.	NAME OF ITEM	COUPLER PLATE (nos.)	NUTS (nos.)	WASHERS (nos.)	BOLTS (nos.)
1	Cable tray of standard length 2.5 meters	4	16	32	16

NOTE: - Based on above table, no. of coupler plates, bolts, washers & nuts shall be calculated for the offered lot. Over & above the calculated quantity, additional 5% coupler plates & 10% bolts, washers & nuts shall be supplied by the bidder.

	2X660MW TALCHER EPC PACKAGE	SPECIFICATION NO. PE-TS-497-507-E013	
		VOLUME II B	
	TECHNICAL SPECIFICATION FOR CABLE TRAY SUPPORT SYSTEM (BOLTABLE TYPE)	SECTION -D	
		REVISION 0	DATE: 23.12.2022
		SHEET 1 OF 1	

DATASHEET A
(SPECIFIC TECHNICAL REQUIREMENTS)

1.0 APPLICABLE STANDARDS:

- a) IS: 2062 For structural steel.
- b) IS: 1079 For hot rolled carbon steel sheet and strip.
- c) IS: 513 For cold rolled low carbon steel sheet & strips
- d) IS: 1730 For dimensions for steel sheet and strip.
- e) IS: 1363 Hexagon head bolts, screws and nuts.
- f) IS: 5 For colours of paint.
- g) IS: 2629 For hot dip galvanising of steel & surface pre-treatment.
- h) IS: 2633 For testing of zinc coating.
- i) IS: 6745 For determining of mass of zinc coating.
- j) IS: 1852 For rolling and cutting tolerances of hot rolled steel products.

2.0 CABLE TRAY SUPPORT

- a) Tray support type: Boltable type
- b) Material: **Hot/ Cold** Rolled MS sheet steel for channel SC1/ DC1 and channel portion of cantilever arms
- c) Thickness: 2.5 mm
- d) Length: Standard length of 6 meters
- e) Fabrication : At works
- f) Construction: Conforming to enclosed drawings [PE-DG-405-507-E013]

3.0 SURFACE TREATMENT:

Galvanizing:

- a) Pre-treatment: As per IS 2629 prior to galvanisation
- b) Type: Hot dip galvanization
- c) Applicable Standard: IS 2629
- d) Minimum thickness: 75 microns (minimum)
- e) Min. weight of Zinc deposit: 610 gms. per square meter
- f) Tests for galvanizing:
 - i) Weight of zinc coating as per IS : 6745
 - ii) Thickness of zinc coating as per IS : 4759
 - iii) Uniformity of zinc coating as per IS : 2633
 - iv) Adhesion as per IS: 2629

	MANUFACTURER/ BIDDER/ SUPPLIER NAME & ADDRESS	STANDARD QUALITY PLAN		SPEC. NO :	DATE:
		CUSTOMER :	QP NO.: PE-QP-999-Q-006, REV-02	DATE: 17.04.2020	
		PROJECT:	PO NO.:	DATE:	
		ITEM: AC ELECT. MOTORS UPTO 55KW (LV (415V))	SYSTEM:	SECTION: II	SHEET 1 of 2

S. NO.	COMPONENT & OPERATIONS	CHARACTERISTICS	CLASS	TYPE OF CHECK	QUANTUM OF CHECK		REFERENCE DOCUMENT	ACCEPTANCE NORMS	FORMAT OF RECORD	AGENCY				REMARKS
					6	M				C/ N	7	8	9	
1	2	3	4	5			M	C	N					
1.0	ASSEMBLY	1.WORKMANSHIP	MA	VISUAL	100%	-	MFG. SPEC.	MFG. SPEC.	LOG BOOK		P	-	-	
		2.DIMENSIONS	MA	VISUAL	100%	-	MFG. DRG./ MFG. SPEC.	MFG. DRG./ MFG. SPEC.	LOG BOOK		P	-	-	
		3.CORRECTNESS COMPLETENESS TERMINATIONS/ MARKING/ COLOUR CODE	MA	VISUAL	100%	-	MFG.SPEC./	MFG.SPEC.	LOG BOOK		P	-	-	
2.0	PAINTING	1.SHADE	MA	VISUAL	SAMPLE	-	MFG. SPEC/ APPROVED DATASHEET	MFG. SPEC/ APPROVED DATASHEET	LOG BOOK	✓	P	V	-	
3.0	TESTS	1.ROUTINE TEST INCLUDING SPECIAL TEST	MA	VISUAL	100%	-	IS-325 / IS-12615/ APPROVED DATA SHEET	IS-325 / IS-12615/ APPROVED DATA SHEET	TEST/ INSPN. REPORT	✓	P	V*	-	* NOTE -1
		2.OVERALL DIMENSIONS & ORIENTATION	MA	MEASUREME NT & VISUAL	100%	-	APPROVED DRG/ DATA SHEET	APPROVED DRG/ DATA SHEET	TEST/ INSPN. REPORT	✓	P	V*	-	* NOTE -1 & NOTE-2

BHEL					
ENGINEERING			QUALITY		
Sign & Date	Name	Checked by:	Sign & Date	Name	
Prepared by: HEMA KUSHWAHA	HEMA KUSHWAHA	Checked by: KUNAL GANDHI			
Reviewed by: PRAVEEN DUTTA	PRAVEEN DUTTA	Reviewed by: RITESH KUMAR JAISWAL			

BIDDER/ SUPPLIER	
Sign & Date	Seal

FOR CUSTOMER REVIEW & APPROVAL			
Doc No:	Sign & Date	Name	Seal
Reviewed by:			
Approved by:			

	MANUFACTURER/ SUPPLIER NAME & ADDRESS	BIDDER/ SUPPLIER NAME & ADDRESS	STANDARD QUALITY PLAN				SPEC. NO :				DATE:			
			CUSTOMER :				QP NO.: PE-QP-999-Q-006, REV-02				DATE: 17.04.2020			
			PROJECT:				PO NO.:				DATE:			
			ITEM: AC ELECT. MOTORS UPTO 55KW (LV (415V))		SYSTEM:		SECTION: II				SHEET 2 of 2			

		3.NAMEPLATE DETAILS	MA	VISUAL	100%	-	IS-325 / IS-12615 / APPROVED DATA SHEET	SAME AS COL. 7	TEST/ INSPN. REPORT	✓	P	V	-	
4.0	PACKING	SURFACE FINISH & COMPLETENESS	MA	VISUAL	100%	100%	AS PER MFG. STANDARD / (#)	AS PER MFG. STANDARD / (#).	INSPC. REPORT	✓	P	W	-	(#) REFER NOTE-8

NOTES:

1. Routine tests on 100% motors shall be done by the vendor. However, BHEL/ Customer shall witness routine tests on random samples. The sampling plan shall be mutually agreed upon.
2. For exhaust/ventilation fan motors of rating up to 1.5 KW, only routine test certificates shall be furnished for scrutiny.
3. In case test certificates for these tests on similar type, size and design of motor from independent laboratory are available, the same is valid for 5 years.
4. BHEL reserves the right to perform repeat test, if required.
5. After packing and prior to issue MDCC, photographs of items to be despatched shall be sent to BHEL for review.
6. In case of any changes in QP commented by customer at contract stage, same shall be carried out by bidder without any implication to BHEL/ Customer.
7. Project specific QP to be developed based on customer requirement.
8. For export job, BHEL technical specification for seaworthy packing to be followed.
9. Packing shall be suitable for storage at site in tropical climate conditions.
10. Latest revision/ year of issue of all the standards (IS/ ASME/ IEC etc.) indicated in QP shall be referred.



LEGENDS:

*RECORDS, IDENTIFIED WITH "TICK"(✓) SHALL BE ESSENTIALLY INCLUDED BY SUPPLIER IN QA DOCUMENTATION,
 ** **M:** SUPPLIER/ MANUFACTURER/ SUB-SUPPLIER, **B:** MAIN SUPPLIER/ BHEL/ THIRD PARTY INSPECTION AGENCY, **C:** CUSTOMER,
P: PERFORM, **W:** WITNESS, **V:** VERIFICATION, AS APPROPRIATE
MA: MAJOR, **MI:** MINOR, **CR:** CRITICAL
D: DOCUMENTATION

BHEL				BIDDER/ SUPPLIER		FOR CUSTOMER REVIEW & APPROVAL			
ENGINEERING		QUALITY		Sign & Date		Doc No:			
Sign & Date	Name	Sign & Date	Name	Seal		Sign & Date	Name	Seal	
Prepared by:	HEMA KUSHWAHA	Checked by:	KUNAL GANDHI			Reviewed by:			
Reviewed by:	PRAVEEN DUTTA	Reviewed by:	RITESH KUMAR JAISWAL			Approved by:			

	MANUFACTURER/ BIDDER/ SUPPLIER NAME & ADDRESS	STANDARD QUALITY PLAN		SPEC. NO.:	DATE: 17,04,2020 SHEET 1 OF 9
		CUSTOMER :		QP NO.: PE-QP-699-Q-007, REV-04	
		PROJECT:		PO NO.:	
		ITEM: AC ELECT. MOTORS 55 KW & ABOVE (LV (415V))	SYSTEM:	SECTION: II	

Sl No.	Component & Operations	Characteristics	Class	Type of Check	Quantum Of check		Reference Document	Acceptance NORMS	FORMAT OF RECORD		AGENCY			
					M	C/N			9	*	**	M	C	N
1.0	RAW MATERIAL & BOUGHT OUT CONTROL													
1.1	SHEET STEEL, PLATES, SECTION, EYEBOLTS	1.SURFACE CONDITION	MA	VISUAL	100%	-	-	FREE FROM BLENKS, CRACKS, WAVINESS ETC	LOG BOOK		P	-	-	
		2.DIMENSIONS	MA	MEASUREMENT	SAMPLE	-	MANUFACTURER'S DRG./SPEC	MANUFACTURER'S DRG./SPEC	LOG BOOK		P	-	-	
		3.PROOF LOAD TEST (EYE BOLT)	MA	MECH. TEST	SAMPLE	-	MANUFACTURER'S DRG./SPEC	MANUFACTURER'S DRG./SPEC	TEST REPORT		P/N	-	-	
1.2	HARDWARES	1.SURFACE CONDITION	MA	VISUAL	100%	-	-	FREE FROM CRACKS, UNEVENNESS ETC.	TEST REPORT		P	-	-	
		2.PROPERTY CLASS	MA	VISUAL	SAMPLES	-	MANUFACTURER'S DRG./SPEC	MANUFACTURER'S DRG./SPEC	TC		P/N	-	-	PROPERTY CLASS MARKING SHALL BE CHECKED BY THE VENDOR
1.3	CASTING	1.SURFACE CONDITION	MA	VISUAL	100%	-	MANUFACTURER'S DRG./SPEC	FREE FROM CRACKS, BLOW HOLES ETC.	LOG BOOK		P/N	-	-	
		2.CHEM. & PHY. PROP.	MA	CHEM & MECH TEST	1/HEAT NO.	-	MANUFACTURER'S DRG./SPEC	MANUFACTURER'S DRG./SPEC	TC		P/N	-	-	HEAT NO. SHALL BE VERIFIED
		3.DIMENSIONS	MA	MEASUREMENT	100%	-	MANUFACTURER'S DRG.	MANUFACTURER'S DRG.	LOG BOOK		P/N	-	-	
1.4	PAINT & VARNISH	1.WAKE, SHADE, SHELF LIFE & TYPE	MA	VISUAL	100%	CONTINUOUS	MANUFACTURER'S DRG./SPEC	MANUFACTURER'S DRG./SPEC	LOG BOOK		P/N	-	-	

BHEL					
ENGINEERING			QUALITY		
Sign & Date	Name		Sign & Date	Name	
Prepared by: HEMA KUSHWAHA	HEMA KHUSHWAHA	Checked by: 	KUNAL GANDHI		
Reviewed by: PRAVEEN DUTTA	PRAVEEN DUTTA	Reviewed by: 	R K JAISWAL		



BIDDER/ SUPPLIER	
Sign & Date	
Seal	

FOR CUSTOMER REVIEW & APPROVAL			
Doc No:			
	Sign & Date	Name	Seal
Reviewed by:			
Approved by:			

16 OF 27

	MANUFACTURER/ BIDDER/ SUPPLIER NAME & ADDRESS	STANDARD QUALITY PLAN			SPEC. NO.:		DATE: 17.04.2020 SHEET 2 OF 9
		CUSTOMER :			QP NO.: PE-QP-999-Q-007, REV-04		
		PROJECT:			PO NO.:		
		ITEM: AC ELECT. MOTORS 55 KW & ABOVE (LV (415V))		SYSTEM:	SECTION: II		

Sl No.	Component & Operations	Characteristics	Class	Type of Check	Quantum Of check		Reference Document	Acceptance NORMS	FORMAT OF RECORD	AGENCY				
					M	C/N				D	M	C	N	
1.5	SHAFT (FORGED OR ROLLED)	1. SURFACE COND.	MA	VISUAL	100%	-	-	FREE FROM VISUAL DEFECTS	LOG BOOK		P	-	-	VENDOR'S APPROVAL IDENTIFICATION SHALL BE MAINTAINED
		2. CHEM. & PHYSICAL PROPERTIES	MA	CHEM. & PHYSICAL TESTS	1/HEAT NO. OR HEAT TREATMENT BATCH NO	-	MANUFACTURER'S DRG/ SPEC.	MANUFACTURER'S DRG/ STD.	TC		P/W	-	-	
		3. DIMENSIONS	MA	MEASUREMENT	100%	-	MANUFACTURER'S DRG/ SPEC.	MANUFACTURER'S DRG.	LOG BOOK		P/W	-	-	
		4. INTERNAL FLAWS	CR	ULTRASONIC TEST	100%	-	ASTM-A388	MANUFACTURER'S STD.	INSPECTION REPORT	✓	P/W	V	-	FOR DIA OF 55 MM & ABOVE
1.6	SPACE HEATERS, CONNECTORS, TERMINAL BLOCKS, CABLES, CABLE LUGS, CARBON BRUSH TEMP. DETECTORS, RTD, BTD'S	1. MAKE & RATING	MA	VISUAL	100%	-	MANUFACTURER'S DRG./STD.	MANUFACTURER'S DRG./STD.	INSPECTION REPORT		P/W	-	-	
		2. PHYSICAL COND.	MA	VISUAL	100%	-	MANUFACTURER'S DRG./STD.	NO PHYS. DAMAGE, NO ELECTRICAL DISCONTINUITY	INSPECTION REPORT		P/W	-	-	
		3. DIMENSIONS (WHEREVER APPLICABLE)	MA	MEASUREMENT	SAMPLE	-	MANUFACTURER'S DRG./ STD	MANUFACTURER'S DRG./ STD.	INSPECTION REPORT		P/W	-	-	
		4. PERFORMANCE/ CALIBRATION	MA	TEST	100%	-	MANUFACTURER'S DRG./ STD	MANUFACTURER'S DRG./ STD.	TEST REPORT		P/W	-	-	

BHEL					
ENGINEERING			QUALITY		
	Sign & Date	Name		Sign & Date	Name
Prepared by:	HEMA KUSHWAHA	HEMA KHUSHWAHA	Checked by:		KUNAL GANDHI
Reviewed by:	PRAVEEN DUTTA	PRAVEEN DUTTA	Reviewed by:		R K JAISWAL

BIDDER/ SUPPLIER	
Sign & Date	
Seal	

FOR CUSTOMER REVIEW & APPROVAL			
Doc No:			
	Sign & Date	Name	Seal
Reviewed by:			
Approved by:			

17 OF 27

	MANUFACTURER/ BIDDER/ SUPPLIER NAME & ADDRESS	STANDARD QUALITY PLAN		SPEC. NO :		
		CUSTOMER :		QP NO.: PE-QP-899-Q-007, REV-04		DATE:17.04.2020
		PROJECT:		PO NO.:		
		ITEM: AC ELECT. MOTORS 55 KW & ABOVE (LV (415V))	SYSTEM:	SECTION: II	SHEET 3 OF 9	

Sl No.	Component & Operations	Characteristics	Class	Type of Check	Quantum Of check		Reference Document	Acceptance NORMS	FORMAT OF RECORD	AGENCY			
					M	C/N				D	M	C	N
1.7	OTHER INSULATING MATERIALS LIKE SLEEVES, BINDINGS CORDS, PAPERS, PRESS BOARDS ETC.	1. SURFACE COND. ETC. 2. DIMENSION (BORE DIA, WALL THICKNESS, BDV AS RECEIVED, BDV AFTER FOLDING AT 180°	MA MA	VISUAL TEST	100% SAMPLE	- -	- MANUFACTURER'S STD.	NO VISUAL DEFECTS MANUFACTURER'S STD.	TEST REPORT LOG BOOK AND OR SUPPLIER'S TC	P/V P/V	- -	- -	
1.8	SHEET STAMPING (PUNCHED)	1. SURFACE COND. 2. DIMENSIONS INCLUDING BURS HEIGHT 3. ACCEPTANCE TESTS	MA MA MA	VISUAL MEASUREMENT ELECT. & MECH TESTS	100% SAMPLE SAMPLE	- - -	- MANUFACTURER'S DRG. MANUFACTURER'S DRG/ STD.	NO VISUAL DEFECTS (FREE FROM BURS) MANUFACTURER'S DRG. MANUFACTURER'S DRG/ STD.	LOG BOOK LOG BOOK TC	P P/V P/V	- - -	- - -	
1.9	CONDUCTORS	1. SURFACE FINISH 2. ELECT. PROP. & MECH. PROP	MA MA	VISUAL ELECT. & MECH. TEST	100% SAMPLES	- -	- MANUFACTURER'S DRG/ SPEC.	FREE FROM VISUAL DEFECTS MANUFACTURER'S / SPEC.	LOG BOOK TC & VENDOR'S TEST REPORTS	*P/V P/V	- -	- -	* MOTOR MANUFACTURER TO CONDUCT VISUAL CHECK FOR SURFACE FINISH ON RANDOM BASIS (10% SAMPLE) AT HIS WORKS AND MAINTAIN RECORD FOR VERIFICATION BY

BHEL					
ENGINEERING			QUALITY		
	Sign & Date	Name		Sign & Date	Name
Prepared by:	HEMA KUSHWAHA	HEMA KHUSHWAHA	Checked by:		KUNAL GANDHI
Reviewed by:	PRAVEEN DUTTA	PRAVEEN DUTTA	Reviewed by:	RITESH JAIN	R K JAISWAL

BIDDER/ SUPPLIER	
Sign & Date	
Seal	

FOR CUSTOMER REVIEW & APPROVAL			
Doc No:			
	Sign & Date	Name	Seal
Reviewed by:			
Approved by:			

18 OF 27

	MANUFACTURER/ BIDDER/ SUPPLIER NAME & ADDRESS	STANDARD QUALITY PLAN		SPEC. NO :	
		CUSTOMER :		QP NO.: PE-QP-699-Q-007, REV-04	
		PROJECT:		PO NO.:	
		ITEM: AC ELECT. MOTORS 55 KW & ABOVE (LV (415V))		SYSTEM:	SECTION: II

DATE:17.04.2020

Sl No.	Component & Operations	Characteristics	Class	Type of Check	Quantum Of check		Reference Document	Acceptance NORMS	FORMAT OF RECORD	AGENCY				
					6	C/N				9	D	M	C	N
1	2	3	4	5	6	C/N	7	8	9	D	M	C	N	
1.10	BEARINGS	3.DIMENSIONS 1.MAKE & TYPE	MA	MEASUREMENT VISUAL	SAMPLES 100%	-	MANUFACTURER'S DRG/ SPEC. MANUFACTURER'S DRG/ APPROVED DATASHEET	MANUFACTURER'S / SPEC. MANUFACTURER'S DRG/ APPROVED DATASHEET	LOG BOOK LOG BOOK		P/V	-	-	
1.11	SLIP RING (WHEREVER APPLICABLE)	2.DIMENSIONS 3.SURFACE FINISH 1.SURFACE COND.	MA	MEASUREMENT VISUAL	SAMPLE 100%	-	APPROVED DATASHEET -	APPROVED DATASHEET/ BEARING MANUF'S CATALOGUES FREE FROM VISUAL DEFECTS	LOG BOOK LOG BOOK		P/V	-	-	
1.12	OIL SEALS & GASKETS	2.DIMENSIONS 3.TEMP.WITHSTAND CAPACITY 4.HVIR 1.MATERIAL OF GASKET	MA	MEASUREMENT ELECT.TEST -DC-	SAMPLE 100%	-	MANUFACTURER'S DRG MANUFACTURER'S STD/ APPROVED DATASHEET	MANUFACTURER'S DRG MANUFACTURER'S STD/ APPROVED DATASHEET	LOG BOOK LOG BOOK		P	-	-	
		2.SURFACE COND. 3.DIMENSIONS	MA	VISUAL MEASUREMENT	100% SAMPLE	-	MANUFACTURER'S DRG/SPECS MANUFACTURER'S DRG	FREE FROM VISUAL DEFECTS MANUFACTURER'S DRG	LOG BOOK LOG BOOK		P	-	-	

BHEL					
ENGINEERING			QUALITY		
Sign & Date	Name		Sign & Date	Name	
Prepared by: HEMA KUSHWAHA	HEMA KHUSHWAHA	Checked by: KUNAL GANDHI	KUNAL GANDHI	KUNAL GANDHI	
Reviewed by: PRAVEEN DUTTA	PRAVEEN DUTTA	Reviewed by: R K JAISWAL	R K JAISWAL	R K JAISWAL	



BIDDER/ SUPPLIER	
Sign & Date	
Seal	

FOR CUSTOMER REVIEW & APPROVAL			
Doc No:			
	Sign & Date	Name	Seal
Reviewed by:			
Approved by:			

19 OF 27

	MANUFACTURER/ BIDDER/ SUPPLIER NAME & ADDRESS	STANDARD QUALITY PLAN		SPEC. NO.:		
		CUSTOMER :		QP NO.: PE-QP-999-Q-007, REV-04		DATE:17.04.2020
		PROJECT:		PO NO.:		
		ITEM: AC ELECT. MOTORS 55 KW & ABOVE (LV (415V))	SYSTEM:	SECTION: II	SHEET 5 OF 9	

Sl No.	Component & Operations	Characteristics	Class	Type of Check	Quantum Of check		Reference Document	Acceptance NORMS	FORMAT OF RECORD		AGENCY							
					M	C/N			9	*	**	D	M	C	N			
2.0	IN PROCESS																	
2.1	STATOR FRAME WELDING (IN CASE OF FABRICATED STATOR)	1.WORKMANSHIP & CLEANNESS	MA	VISUAL	100%		MANUFACTURER'S DRG	GOOD FINISH	LOG BOOK			PW	-	-				
		2.DIMENSIONS	MA	MEASUREMENT	100%		MANUFACTURER'S DRG	MANUFACTURER'S DRG	LOG BOOK			P	-	-				
2.2	MACHINING	1.FINISH	MA	VISUAL	100%		-DC-	GOOD FINISH	LOG BOOK			P	-	-				
		2.DIMENSIONS	MA	MEASUREMENT	100%		MANUFACTURER'S DRG	MANUFACTURER'S DRG	LOG BOOK			P	-	-				
		3.SHAFT SURFACE FLOWS	MA	PT	100%		MANUFACTURER'S STD/ASTM E165	MANUFACTURER'S STD/ APPROVED DATASHEET.	LOG BOOK	✓		P	V	-				
2.3	PAINTING	1.SURFACE PREPARATION	MA	VISUAL	100%		MANUFACTURER'S STD/APPROVED DATASHEET	MANUFACTURER'S STD/APPROVED DATASHEET	LOG BOOK			P	-	-				
		2.PAINT THICKNESS (BOTH PRIMER & FINISH COAT)	MA	MEASUREMENT BY ELCOMETER	SAMPLE		MANUFACTURER'S STD/APPROVED DATASHEET	MANUFACTURER'S STD/APPROVED DATASHEET	LOG BOOK			P	-	-				
		3.SHADE	MA	VISUAL	SAMPLE		MANUFACTURER'S STD/APPROVED DATASHEET	MANUFACTURER'S STD/APPROVED DATASHEET	LOG BOOK			P	-	-				
		4.ADHESION	MA	CROSS CUTTING & TAPE TEST	SAMPLE		MANUFACTURER'S STD/APPROVED DATASHEET	MANUFACTURER'S STD/APPROVED DATASHEET	LOG BOOK			P	-	-				

BHEL					
ENGINEERING			QUALITY		
	Sign & Date	Name		Sign & Date	Name
Prepared by:	HEMA KUSHWAHA	HEMA KHUSHWAHA	Checked by:		KUNAL GANDHI
Reviewed by:		PRAVEEN DUTTA	Reviewed by:		R K JAISWAL

BIDDER/ SUPPLIER	
Sign & Date	
Seal	

FOR CUSTOMER REVIEW & APPROVAL			
Doc No:			
	Sign & Date	Name	Seal
Reviewed by:			
Approved by:			

20 OF 27

	MANUFACTURER/ BIDDER/ SUPPLIER NAME & ADDRESS	STANDARD QUALITY PLAN		SPEC. NO.:		
		CUSTOMER :		QP NO.: PE-QP-999-Q-007, REV-04		DATE: 17.04.2020
		PROJECT:		PO NO.:		
		ITEM: AC ELECT. MOTORS 55 KW & ABOVE (LV (415V))		SYSTEM:	SECTION: II	SHEET 6 OF 9

Sl No.	Component & Operations	Characteristics	Class	Type of Check	Quantum Of check		Reference Document	Acceptance NORMS	FORMAT OF RECORD		AGENCY			
					M	C/N			9	*	**	D	M	C
2.4	SHEET STACKING	1.COMPLETENESS	MA	MEASUREMENT	SAMPLE	-	MANUFACTURER'S STD.	MANUFACTURER'S STD.	LOG BOOK		P	-	-	
		2.COMPRESSION & TIGHTENING	MA	MEASUREMENT	100%	-	MANUFACTURER'S STD.	MANUFACTURER'S STD.	LOG BOOK		P	-	-	
2.5	WINDING	1.COMPLETENESS	CR	VISUAL	100%	-	MANUFACTURER'S STD./APPROVED DATASHEET	MANUFACTURER'S STD./APPROVED DATASHEET	LOG BOOK		P	-	-	
		2.CLEANLINESS	CR	VISUAL	100%	-	MANUFACTURER'S STD./APPROVED DATASHEET	MANUFACTURER'S STD./APPROVED DATASHEET	LOG BOOK		P	-	-	
		3.IR+IV-IR	CR	ELECT. TEST	100%	-	IS-325/IS-12615/IEC-60034 PART-1	IS-325/IS-12615/IEC-60034 PART-1	TEST/INSPC. REPORT	✓	P	V	-	
		4.RESISTANCE	CR	ELECT. TEST	100%	-	IS-325/IS-12615/IEC-60034 PART-1	IS-325/IS-12615/IEC-60034 PART-1	TEST/INSPC. REPORT	✓	P	V	-	
		5.INTERTURN INSULATION	CR	ELECT. TEST	100%	-	IS-325/IS-12615/IEC-60034 PART-1	IS-325/IS-12615/IEC-60034 PART-1	TEST/INSPC. REPORT		P	-	-	
2.6	IMPREGNATION	1.VISCOSITY	MA	PHY. TEST	AT STARTING	-	MANUFACTURER'S STANDARD	MANUFACTURER'S STANDARD	LOG BOOK		P	-	-	
		2.TEMP. PRESSURE VACCUM	MA	PROCESS CHECK	CONTINUOUS	-	MANUFACTURER'S STANDARD	MANUFACTURER'S STANDARD	LOG BOOK		P	-	-	
		3.NO. OF DIPS	MA	PROCESS CHECK	CONTINUOUS	-	MANUFACTURER'S STANDARD	MANUFACTURER'S STANDARD	LOG BOOK	✓	P	V	-	THREE DIPS TO BE GIVEN

BHEL					
ENGINEERING			QUALITY		
	Sign & Date	Name		Sign & Date	Name
Prepared by:	HEMA KUSHWAHA	HEMA KHUSHWAHA	Checked by:	KUNAL GANDHI	KUNAL GANDHI
Reviewed by:	PRAVEEN DUTTA	PRAVEEN DUTTA	Reviewed by:	RITESH KUMAR JAIN	R K JAISWAL



BIDDER/ SUPPLIER	
Sign & Date	
Seal	

FOR CUSTOMER REVIEW & APPROVAL			
Doc No:			
	Sign & Date	Name	Seal
Reviewed by:			
Approved by:			

21 OF 27

	MANUFACTURER/ BIDDER/ SUPPLIER NAME & ADDRESS	STANDARD QUALITY PLAN		SPEC. NO.:	DATE:17.04.2020
		CUSTOMER :		QP NO.: PE-QP-899-Q-007, REV-04	
		PROJECT:		PO NO.:	
		ITEM: AC ELECT. MOTORS 55 KW & ABOVE (LV (415V))	SYSTEM:	SECTION: II	

Sl No.	Component & Operations	Characteristics	Class	Type of Check	Quantum Of check		Reference Document	Acceptance NORMS	FORMAT OF RECORD	AGENCY			
					M	C/N				D	M	C	N
2.7	COMPLETE STATOR ASSEMBLY	4.DURATION 1.COMPACTNESS & CLEANLINESS	MA MA	PROCESS CHECK VISUAL	CONTINUOUS 100%	- -	MANUFACTURER'S STANDARD MANUFACTURER'S STANDARD	MANUFACTURER'S STANDARD MANUFACTURER'S STANDARD	LOG BOOK LOG BOOK	✓ -	P P	V -	- -
2.8	BRAZING/COMPRESSION JOINT	1.COMPLETENESS 2.SOUNDNESS	CR CR	VISUAL MALLETT TEST & UT	100% 100%	- -	MANUFACTURER'S STANDARD MANUFACTURER'S STANDARD	MANUFACTURER'S STANDARD MANUFACTURER'S STANDARD	LOG BOOK TEST INSPEC. REPORT	✓ -	P P	- V	- -
2.9	COMPLETE ROTOR ASSEMBLY	3.HV 1.RESIDUAL UNBALANCE	MA CR	ELECT. TEST DYN. BALANCE	100% 100%	- -	MANUFACTURER'S STANDARD MANUFACTURER'S SPEC./ ISO 1940	MANUFACTURER'S STANDARD MANUFACTURER'S DWG.	TEST INSPEC. REPORT LOG BOOK	✓ -	P P	V -	- -
2.10	ASSEMBLY	2.SOUNDNESS OF DIE CASTING	CR	ELECT. (GROWLER TEST)	100%	-	MANUFACTURER'S SPEC.	MANUFACTURER'S SPEC.	TEST INSPEC. REPORT	✓	P	V	-
		1.ALIGNMENT 2.WORKMANSHIP 3.AXIAL PLAY 4.DIMENSIONS	MA MA MA MA	MEAS. VISUAL MEAS. MEAS.	100% 100% 100% 100%	- - - -	MANUFACTURER'S SPEC. MANUFACTURER'S SPEC. MANUFACTURER'S SPEC. MANUFACTURER'S DRG./ MANUFACTURER'S SPEC.	MANUFACTURER'S SPEC. MANUFACTURER'S SPEC. MANUFACTURER'S SPEC. MANUFACTURER'S DRG./ MANUFACTURER'S SPEC.	LOG BOOK LOG BOOK LOG BOOK LOG BOOK	✓ - - -	P P P P	- - V -	- - - -
		5.CORRECTNESS, COMPLETENESS TERMINATIONS/ MARKING/ COLOUR CODE 6. RTD, BTD & SPACE HEATER MOUNTING.	MA MA	VISUAL VISUAL	100% 100%	- -	MANUFACTURER'S SPEC. MANUFACTURER'S SPEC.	MANUFACTURER'S SPEC. MANUFACTURER'S SPEC.	LOG BOOK LOG BOOK	✓ -	P P	- V	- -

BHEL					
ENGINEERING			QUALITY		
Sign & Date		Name	Sign & Date		Name
Prepared by:	HEMA KUSHWAHA	HEMA KHUSHWAHA	Checked by:		KUNAL GANDHI
Reviewed by:	PRAVEEN DUTTA	PRAVEEN DUTTA	Reviewed by:		R K JAISWAL

BIDDER/ SUPPLIER	
Sign & Date	
Seal	

FOR CUSTOMER REVIEW & APPROVAL			
Doc No:	Sign & Date	Name	Seal
Reviewed by:			
Approved by:			

22 OF 27

	MANUFACTURER/ BIDDER/ SUPPLIER NAME & ADDRESS	STANDARD QUALITY PLAN		SPEC. NO :		
		CUSTOMER :		QP NO.: PE-QP-999-Q-007, REV-04		DATE:17,04,2020
		PROJECT:		PO NO.:		
		ITEM: AC ELECT. MOTORS 55 KW & ABOVE (LV (415V))		SYSTEM:		SECTION: II

Sl No.	Component & Operations	Characteristics	Class	Type of Check	Quantum Of check		Reference Document	Acceptance NORMS	FORMAT OF RECORD	AGENCY				
					M	C/N				D	M	C	N	
3.0	TESTS	1.TYPE TESTS INCLUDING SPECIAL TESTS	MA	ELECT.TEST	1/TYPE/SIZE	1/TYPE/SIZE	IS-325/IS-12615/APPROVED DATASHEET	IS-325/IS-12615/APPROVED DATASHEET	TEST REPORT	✓	P	W*	-	* NOTE =1
		2.ROUTINE TESTS INCLUDING SPECIAL TEST	MA	ELECT.TEST	100%	-	IS-325/IS-12615/APPROVED DATASHEET	IS-325/IS-12615/APPROVED DATASHEET	TEST REPORT	✓	P	V [§]	-	§ NOTE =2
		3.VIBRATION & NOISE LEVEL	MA	ELECT.TEST	100%	-	IS: 12075 / IEC 60034-14 & IS-12065	IS: 12075 / IEC 60034-14 & IS-12065	TEST REPORT	✓	P	V [§]	-	§ NOTE =2
		4.OVERALL DIMENSIONS AND ORIENTATION	MA	MEASUREMENT & VISUAL	100%	100%	APPROVED DRG/DATA SHEET	APPROVED DRG/DATA SHEET &	TEST/INSPC. REPORT	✓	P	W	-	
		5.DEGREE OF PROTECTION	MA	ELECT. & MECH.TEST	1/TYPE/ SIZE	-	IEC 60034-5/IS-12615	APPROVED DATASHEET	TC	✓	P	V	-	TC FROM AN INDEPENDENT LABORATORY, REFER NOTE-3
		6. MEASUREMENT OF RESISTANCE OF RTD & BTD	MA	ELECT. & MECH. TEST	100%	-	IS-325/IS-12615/IEC-60034 PART-1/IS: 12802	IS-325/IS-12615/IEC-60034 PART-1/IS: 12802	TC	✓	P	V [§]	-	§ NOTE =2
		7. MEASUREMENT OF RESISTANCE, R OF SPACE HEATER	MA	ELECT. & MECH. TEST	100%	-	IS-325/IS-12615/IEC-60034 PART-1	IS-325/IS-12615/IEC-60034 PART-1	TC	✓	P	V [§]	-	§ NOTE =2
		8. NAME PLATE DETAILS	MA	VISUAL	100%	-	IS-325/IS-12615& DATA SHEET	IS-325/IS-12615 & DATA SHEET	TEST/INSPC. REPORT	✓	P	V [§]	-	§ NOTE =2
		9.EXPLOSION FLAME PROOF NESS (IF SPECIFIED)	MA	EXPLOSION FLAME PROOF TEST	1/TYPE	-	IS 2148 / IEC 60079-1	IS 2148 / IEC 60079-1	TC	✓	P	V	-	TC FROM AN INDEPENDENT LABORATORY, REFER NOTE-3
		10. PAINT SHADE, THICKNESS & FINISH	MA	VISUAL & MEASUREMENT BY ELKOMETER	SAMPLE	SAMPLE	APPROVED DATASHEET	APPROVED DATASHEET	TC	✓	P	W [§]	-	SAMPLING PLAN TO BE DECIDED BY INSPECTION AGENCY § NOTE =2

BHEL					
ENGINEERING			QUALITY		
	Sign & Date	Name		Sign & Date	Name
Prepared by:	HEMA KUSHWAHA	HEMA KHUSHWAHA	Checked by:		KUNAL GANDHI
Reviewed by:	PRAVEEN DUTTA	PRAVEEN DUTTA	Reviewed by:	RITESH KUMAR JAISWAL	R K JAISWAL

BIDDER/ SUPPLIER	
Sign & Date	
Seal	

FOR CUSTOMER REVIEW & APPROVAL			
Doc No:			
	Sign & Date	Name	Seal
Reviewed by:			
Approved by:			

23 OF 27

	MANUFACTURER/ BIDDER/ SUPPLIER NAME & ADDRESS	STANDARD QUALITY PLAN		SPEC. NO :		DATE:17.04.2020 SHEET 9 OF 9
		CUSTOMER :		QP NO.: PE-QP-999-Q-007, REV-04		
		PROJECT:		PO NO.:		
		ITEM: AC ELECT., MOTORS 55 KW & ABOVE (LV (415V))	SYSTEM:	SECTION: II		

Sl No.	Component & Operations	Characteristics	Class	Type of Check	Quantum Of check		Reference Document	Acceptance NORMS	FORMAT OF RECORD	AGENCY				
					M	C/N				D	M	C	N	
4.0	PACKING	SURFACE FINISH & COMPLETENESS	MA	VISUAL	100%	100%	AS PER MANUFACT. STANDARD / (#)	AS PER MANUFACT. STANDARD / (#)	INSPC. REPORT	✓	P	W	•	(#): REFER NOTE-8

NOTES:

- 1 DEPENDING UPON THE SIZE AND CRITICALLY, WITNESSING BY BHEL SHALL BE DECIDED.
- 2 ROUTINE TESTS ON 100% MOTORS SHALL BE DONE BY THE VENDOR, HOWEVER, BHEL/CUSTOMER SHALL WITNESS ROUTINE TESTS ON RANDOM SAMPLES, THE SAMPLING PLAN SHALL BE MUTUALLY AGREED UPON.
- 3 IN CASE TEST CERTIFICATES FOR THESE TESTS ON SIMILAR TYPE, SIZE AND DESIGN OF MOTOR FROM INDEPENDENT LABORATORY ARE AVAILABLE, THE SAME IS VALID FOR 5 YEARS.
- 4 BHEL RESERVES THE RIGHT TO PERFORM REPEAT TEST, IF REQUIRED.
- 5 AFTER PACKING AND PRIOR TO ISSUE MDCC, PHOTOGRAPHS OF ITEMS TO BE DESPATCHED SHALL BE SENT TO BHEL PURCHASE GROUP FOR REVIEW.
- 6 IN CASE , ANY CHANGES IN QP COMMENTED BY CUSTOMER AT CONTRACT STAGE SHALL BE CARRIED OUT BY BIDDER WITHOUT ANY IMPLICATION TO BHEL/ CUSTOMER.
- 7 PROJECT SPECIFIC QP TO BE DEVELOPED BASED ON CUSTOMER REQUIREMENT.
- 8 FOR EXPORT JOB, BHEL TECHNICAL SPECIFICATION FOR SEAWORTHY PACKING TO BE FOLLOWED.
- 9 PACKING SHALL BE SUITABLE FOR STORAGE AT SITE IN TROPICAL CLIMATE CONDITIONS.
- 10 LATEST REVISION/ YEAR OF ISSUE OF ALL THE STANDARDS (IS/ ASME/ IEC ETC.) INDICATED IN QP SHALL BE REFERRED.

LEGENDS:

*RECORDS, IDENTIFIED WITH "TICK"(✓) SHALL BE ESSENTIALLY INCLUDED BY SUPPLIER IN QA DOCUMENTATION.
 ** M: SUPPLIER/ MANUFACTURER/ SUB-SUPPLIER, B: MAIN SUPPLIER/ BHEL/ THIRD PARTY INSPECTION AGENCY, C: CUSTOMER,
 P: PERFORM, W: WITNESS, V: VERIFICATION, AS APPROPRIATE
 MA: MAJOR, M: MINOR, CR: CRITICAL
 D: DOCUMENT

BHEL					
ENGINEERING			QUALITY		
	Sign & Date	Name		Sign & Date	Name
Prepared by:	HEMA KUSHWAHA	HEMA KHUSHWAHA	Checked by:		KUNAL GANDHI
Reviewed by:	PRAVEEN DUTTA	PRAVEEN DUTTA	Reviewed by:	RITESH KUMAR JAISWAL	R K JAISWAL

BIDDER/ SUPPLIER	
Sign & Date	
Seal	

FOR CUSTOMER REVIEW & APPROVAL			
Doc No:			
	Sign & Date	Name	Seal
Reviewed by:			
Approved by:			



SUB-SECTION-E-42

MOTORS

**TALCHER THERMAL POWER PROJECT
STAGE-III (2 X 660 MW)
EPC PACKAGE**

**TECHNICAL SPECIFICATION
SECTION-VI, PART-B
BID DOC NO.:CS-4540-001A-2**



CLAUSE NO.

QUALITY ASSURANCE

MOTOR

TESTS/CHECKS TEMS/COMPONENTS	Visual	Dimensional	Make/Type/Rating /General Physical Inspection	Mech/Chem. Properties	NDT /DP/MPI/UT	Metallography	Electrical Characteristics	Welding/Brazing(WPS/PQR)	Heat Treatment	Magnetic Characteristics	Hydraulic/Leak/Pressure Test	Thermal Characteristics	Run out	Dynamic Balancing	Routine & Acceptance tests as per IS-4722 /IS- 9283/IS 2148/IEC60034/IEC 60079-II IS-12615	Vibration	Over speed	Tan delta, shaft voltage & polarization index test	Paint shade, thickness & adhesion
Plates for stator frame, end shield, spider etc.	Y	Y	Y	Y	Y				Y										
Shaft	Y	Y	Y	Y	Y	Y			Y										
Magnetic Material	Y	Y	Y	Y			Y			Y		Y							
Rotor Copper/Aluminium	Y	Y	Y	Y			Y		Y										
Stator copper	Y	Y	Y	Y			Y		Y			Y							
SC Ring	Y	Y	Y	Y	Y		Y	Y	Y										
Insulating Material	Y	Y	Y	Y			Y					Y							
Tubes, for Cooler	Y	Y	Y	Y	Y				Y		Y								
Sleeve Bearing	Y	Y	Y	Y	Y				Y		Y								
Stator/Rotor, Exciter Coils	Y	Y	Y				Y	Y											
Castings, stator frame, terminal box and bearing housing etc.	Y	Y	Y	Y	Y			Y											
Fabrication & machining of stator, rotor, terminal box	Y	Y			Y			Y	Y										
Wound stator	Y	Y					Y	Y											
Wound Exciter	Y	Y					Y	Y											
Rotor complete	Y	Y					Y						Y	Y					
Exciter, Stator, Rotor, Terminal Box assembly	Y	Y					Y												
Accessories, RTD, BTD, CT, Space heater, antifriction bearing, gaskets etc.	Y	Y	Y																

TALCHER THERMAL POWER PROJECT
STAGE-III (2X660 MW)
EPC PACKAGE

TECHNICAL SPECIFICATIONS
SECTION – VI, PART-B
BID DOC.NO.: CS-4540-001A-2

SUB-SECTION –E-47
MOTOR

Page
1 of 2

CLAUSE NO.	QUALITY ASSURANCE															
------------	--------------------------	--	--	--	--	--	--	--	--	--	--	--	--	---	--	--

Complete Motor	Y	Y	Y													Y	Y	Y	Y1	Y
----------------	---	---	---	--	--	--	--	--	--	--	--	--	--	--	--	---	---	---	----	---

Note:
 1. The manufacture is to furnish a detailed Quality Plan indicating the practices & Procedure followed along with relevant supporting documents during QP finalization. However, following methodology to be followed for Inspection Categorization:

Note for LT Motor:
i) Motor rating up to 50 KW: Inspection CAT- III : Acceptance of Motor up to 50 KW is based on COC of the Manufacturer and Main Contractor confirming as follows:
 "It is hereby confirmed that the above mentioned motor /motors was/ were manufactured taking care of NTPC specific requirements regarding ambient temp., voltage frequency variation, hot starts, pull out torque, starting KVA/KW, temperature rise, distance between center of stud gland plate and tested in accordance with approved drawing /data sheets."
ii) Motor rating above 50 KW & less than 75 KW: Inspection CAT- II as per NTPC approved MQP: Acceptance of Motor rating above 50 KW & less than 75 KW is based on NTPC review of Routine Test inspection report as per IS:12615 - 2018 (including latest revision) duly witnessed by main contractor along with COC of the Manufacturer and Main Contractor confirming as follows:
 "It is hereby confirmed that the above mentioned motor /motors was/ were manufactured taking care of NTPC specific requirements regarding ambient temp., voltage frequency variation, hot starts, pull out torque, starting KVA/KW, temperature rise, distance between center of stud gland plate, space heater and tested in accordance with approved drawing /data sheets."
iii) Motor rating 75 KW & above: Inspection CAT-I: As per NTPC approved MQP.

2. Additional routine tests for Flame proof motors shall be applicable as per relevant standard
 3. Makes of major bought out items for HT motors will be subject to NTPC approval.
 4. Y1 = for HT Motor / Machines only.
 5. For LT Motors, stator core stack length & grade, no load loss and winding resistance w.r.t. type tested motor for IE2/IE3 shall be checked/verified in addition to Compliance of relevant standard IS:12615/IEC requirement. In case actual results are not within the tolerance limit as declared by manufacturer during QP submission, the motor shall be subjected to efficiency test.



SUB-SECTION–E-40

L.T. POWER CABLE
&
CONTROL CABLE

TALCHER THERMAL POWER PROJECT
STAGE-III (2 X 660 MW)
EPC PACKAGE

TECHNICAL SPECIFICATION
SECTION-VI, PART-B
BID DOC NO.:CS-4540-001A-2



CLAUSE NO.

QUALITY ASSURANCE

LT Power Cables & Control Cables

Attributes / Characteristics	Item / Components / Sub System Assembly	Make, Type & T.C as per relevant standard	Dimension/surface finish	Mechanical properties	Chemical Composition	Spark Test(as applicable)	Electrical properties	Hot Set Test/ Eccentricity & Ovality	Lay length & Sequence	Armour coverage, cross over, looseness, gap between two	Sequential marking/ Batch marking/ surface finish/ cable length	T.S & elongation before & after ageing on outer sheath & insulation	Thermal stability	Anti termite coating on wooden	Constructional requirements feature as per specification	Routine & Acceptance Tests as per relevant standard & specification	FRLS Tests
	Aluminum (IEC 60228)	Y	Y	Y	Y		Y										
	Copper (IEC 60228)	Y	Y	Y	Y		Y										
	XLPE Compound (IEC 60502-2 (2005))	Y		Y			Y	Y				Y					
	PVC insulation Compound (IEC 60502)	Y		Y			Y					Y	Y				
	FRLS PVC Compound (IEC-60754 Part-1)	Y		Y								Y	Y				Y
	Extrusion & curing /Manufacturing of Core (PVC / XLPE)		Y			Y	Y						Y				
	Core Laying								Y								
	Armour wire/strip	Y	Y	Y													
	Inner sheath	Y	Y														
	Armouring		Y							Y							
	Outer Sheathing		Y								Y						
	Finished Cable (IEC-60754 Part-1, IEC 60332 part III cat B/relevant standard)								Y	Y	Y	Y	Y	Y	Y	Y	Y
	Wooden drum(relevant standard) /Steel Drum		Y											Y	Y		

Notes:

- This is an indicative list of tests / checks. The manufacturer is to furnish a detailed Quality Plan indicating the practice and procedure along with relevant supporting documents.
- Make of all major Bought out items will be subject to Owner's approval.

TALCHER THERMAL POWER PROJECT
STAGE-III (2X660 MW)
EPC PACKAGE

TECHNICAL SPECIFICATIONS
SECTION – VI, PART-B
BID DOC.NO.: CS-4540-001A-2

SUB-SECTION –E-40
LT POWER CABLES & CONTROL
CABLES

Page
1 of 4



QUALITY ASSURANCE

CLAUSE NO.

ROUTINE TESTS	Following routine tests shall be carried out on each drum of finished cables for all types (PVC / XLPE insulated) & sizes.	
1)	Conductor Resistance test	
2)	High voltage test	
ACCEPTANCE TESTS	Following Acceptance tests shall be carried out on each size of each type (PVC / XLPE insulated) of cables, in the offered lot.	
A) For Conductor (as per sampling plan mentioned in IEC Pub 502 (1983)/ BS 6346:1969/ IEC 60502-2 (2005))		
	1)	Annealing test (Copper)
	2)	Tensile Test (Aluminum)
	3)	Wrapping Test (Aluminum)
	4)	Resistance test
B) For Armour Wires / Formed Wires (If applicable) (as per sampling plan mentioned in IEC Pub 502 (1983)/ BS 6346:1969/ IEC 60502-2 (2005))		
	1.	Measurement of Dimensions
	2.	Tensile Tests
	3.	Elongation Test
	4.	Torsion Test For Round wires only
	5.	Wrapping Test
	6.	Resistance Test
	7.	Mass of Zinc coating test For G S wires / Formed wires only
	8.	Uniformity of Zinc coating For G S wires / Formed wires only
	9.	Adhesion test For G S wires / Formed wires only
	10.	Freedom from surface defects
C) For PVC / XLPE insulation & PVC Sheath (as per sampling plan mentioned in IEC Pub 502 (1983)/ BS 6346:1969/ IEC 60502-2 (2005))		
	1)	Test for thickness
	2)	Tensile strength & Elongation before ageing(for tests after ageing see "D")
	3)	Hot set test (For XLPE insulation)

TALCHER THERMAL POWER PROJECT
STAGE-III (2X660 MW)
EPC PACKAGE

TECHNICAL SPECIFICATIONS
SECTION – VI, PART-B
BID DOC.NO.: CS-4540-001A-2

SUB-SECTION –E-40
LT POWER CABLES & CONTROL
CABLES

Page
2 of 4

CLAUSE NO.	QUALITY ASSURANCE		
	D) Ageing test:		
	If the compound manufacturer is carrying out Ageing test, test report of compound manufacturer is to be reviewed. If the compound manufacturer is not carrying out ageing test, then cable manufacturer will carry out ageing test & the test report will be reviewed by owner (quantum of ageing test sample shall be one sample /batch)		
	E) Following tests will be carried out on completed cables as per relevant standard on each size of each type (PVC / XLPE insulated)		
	1)	Insulation resistance test (Volume resistivity method)	
	2)	High voltage test	
	F) Following tests shall be carried out on only one size of offered lot (comprising of all sizes & types)		
	1)	Thermal stability test on PVC insulation and outer sheath	
	2)	Oxygen index test on outer sheath	
	3)	Smoke density rating test on outer sheath	
	4)	Acid gas generation test on outer sheath	
	G) Flammability test as per IEC 60332 - Part- 3 (Category- B) on completed cables as per following sampling plan:		
		<p>This test will be carried out using composite sampling i.e. irrespective of size; cables of one particular type (i.e. armoured PVC insulated, unarmoured PVC insulated, armoured XLPE insulated, unarmoured XLPE insulated) will be bunched together, as per calculations in line with the IEC. All sizes of PVC & XLPE insulated, armoured & unarmoured cables shall be covered.</p> <p>For one particular type, cables with OD less than or equal to 30 mm shall be clubbed together in touching formation while cables with OD greater than 30 mm shall be clubbed together leaving a gap equal to OD of cable having least diameter. Cable OD shall be taken as nominal overall diameter as per approved datasheet.</p>	
	H) Following tests shall be carried on one length of each size of each type (PVC / XLPE insulated) of offered lot:		
	1)	Constructional / dimensional check, surface finish, length measurement, sequence of cores, armour coverage, Gap between two consecutive armour wires / formed wires, Sequential marking, drum / Batch (outer sheath extrusion batch)number marking on sheath	
	2)	Measurement of Eccentricity & Ovality	
	GENERAL NOTE:		
	<p>(a) In case of manufacturers / supplier who have supplied cables in the past through Corporate Centre:- Routine Test of manufacturer internal test report are to be verified by owner and Main Contractor at the time of final inspection. Owner and Main Contractor will also witness routine tests on cables on 10% sample basis.</p> <p>(b) In case of manufacturers / supplier WHO HAVE NOT SUPPLIED cables in the past through Corporate Centre:- Routine Test of manufacturer internal test report are to be verified by Owner at the time of final inspection. Owner will witness routine tests on cables for the first order on 10% sample basis and Main Contractor will witness routine tests on cables for the first order on 100% basis.</p>		
<p>TALCHER THERMAL POWER PROJECT STAGE-III (2X660 MW) EPC PACKAGE</p>	<p>TECHNICAL SPECIFICATIONS SECTION – VI, PART-B BID DOC.NO.: CS-4540-001A-2</p>	<p>SUB-SECTION –E-40 LT POWER CABLES & CONTROL CABLES</p>	<p>Page 3 of 4</p>

CLAUSE NO.	QUALITY ASSURANCE			
	<p>1. For Smoke Density rating test: if the test result without conditioning is within (-)10% of the maximum specified value, then, retesting is to be carried out with conditioning of samples as per standard and the test results after conditioning shall be final for acceptance/rejection.</p> <p>2. For Acid Gas Generation test: if the test result without conditioning is within (-)10% of the maximum specified value, then, retesting is to be carried out with conditioning of samples as per standard and the test results after conditioning shall be final for acceptance/rejection.</p> <p>3. For Oxygen Index test: if the test result without conditioning is within (+)7% of the minimum specified value, then, retesting is to be carried out with conditioning of samples as per standard and the test results after conditioning shall be final for acceptance/rejection.</p> <p>4. In case the test results without conditioning do not meet the maximum/minimum specified value, the manufacturer may exercise the option of retesting the samples after conditioning as per standard.</p>			
<p>TALCHER THERMAL POWER PROJECT STAGE-III (2X660 MW) EPC PACKAGE</p>	<p>TECHNICAL SPECIFICATIONS SECTION – VI, PART-B BID DOC.NO.: CS-4540-001A-2</p>	<p>SUB-SECTION –E-40 LT POWER CABLES & CONTROL CABLES</p>	<p>Page 4 of 4</p>	

QUALITY ASSURANCE

CABLING, EARTHING, LIGHTNING PROTECTION

ATTRIBUTES / CHARACTERISTICS ITEMS/COMPONENTS / SUB SYSTEMS	Dimension	Paint shade, paint thickness, adhesion	Pre-treatment of sheet	IP protection	Proof load*	Surface finish	Deflection test*	HV & IR	Galvanise Test (If Applicable)	Functional	Bought out items/Bill of material	Routine tests as per relevant standard & specification	Acceptance tests as per relevant standard & specification	Constructional feature as per NTPC Specification
Wall Mounted-Lighting Panel (IS-513, IS:5, IS:2629, 2633, 6745)	Y	Y	Y	Y		Y		Y		Y	Y	Y	Y	Y
Switch box/junction box/ Receptacles Panel (IS-513, IS:5, IS:2629, 2633, 6745)	Y	Y	Y	Y		Y		Y	Y	Y	Y	Y	Y	Y
Cable glands(BS-6121)	Y													Y
Cable lug	Y													Y
Lighting wire (IS-694)	Y											Y		
Flexible conduits	Y											Y		Y
Conduits (Galvanise & Epoxy) IS-9537 & IS-2629, 2633, 6745	Y		Y					Y				Y		Y
RCC Hume Pipe (IS-458)												Y		
Cable termination & straight through joint (IS 13573)	Y											Y		Y
Cable Trays, bends, tees, crosses, Flexible supports system & accessories IS-513, 2629,2633,6745	Y		Y		Y	Y	Y		Y			Y	Y	Y
Trefoil clamp	Y													Y
GI flats for earthing & lighting protection (IS 2062, 2629, 6745,2633)	Y		Y						Y			Y		Y
GI wire (IS-280)	Y											Y		
Fire Sealing System (BS -476)												Y	Y	Y

.Note:1.This is an indicative list of tests /checks. The manufacturer is to furnish a detailed Quality Plan indicating the practice and procedure along with relevant supporting documents.

2.* Deflection Test on cable trays and Proof Load test on cable trays support system will be as per details given in the NTPC technical specification & approved MQP. The above acceptance tests shall be done only on one sample from each size of offered lot. This test is not applicable on bends, tees & crosses.

3. Make of all items will be subject to NTPC approval.

LOAD TITLE	RATING (KW / A)		UNIT (U)/STN (S)	Nos.		VOLTAGE CODE*	FEEDER CODE**	EMER. LOAD (Y)	CONT.(C)/ INTT.(I)	STARTING TIME >5 SEC (Y)	LOCATION	BOARD NO.	CABLE		BLOCK CABLE DRG. No.	CONTROL CODE	REMARKS	LOAD No.
	NAME PLATE	MAX. CONT. DEMAND (MCR)		RUNNING	STANDBY								SIZE CODE	NOs				
1	2	3	4	5	6	7	8	9	10	11	12	13	14	15	16	17	18	19

ANNEXURE-III

NOTES: 1. COLUMN 1 TO 12 & 18 SHALL BE FILLED BY THE REQUISITIONER (ORIGINATING AGENCY); REMAINING COLUMNS ARE TO BE FILLED UP BY PEM (ELECTRICAL)/ CUSTOMER
 2. ABBREVIATIONS : * VOLTAGE CODE (7):- (ac) A=11 KV, B=6.6 KV, C=3.3 KV, D=415 V, E=240 V (1 PH), F=110 V (cc): G=220 V, H=110 V, J=48 V, K=+24V, L=-24 V
 : ** FEEDER CODE (8):- U=UNIDIRECTIONAL STARTER, B=BI-DIRECTIONAL STARTER, S=SUPPLY FEEDER, D=SUPPLY FEEDER (CONTACTER CONTROLLED)

LOAD DATA (ELECTRICAL)	JOB NO.		ORIGINATING AGENCY	PEM (ELECTRICAL)
	PROJECT TITLE		NAME	DATA FILLED UP ON
	SYSTEM		SIGN.	DATA ENTERED ON
	DEPTT. / SECTION	MAUX	SHEET 1 OF 1	REV. 00
			DE'S SIGN. & DATE	

26 OF 27

1236331/2023/PS-PEM-MAX

Explanatory notes for filling up cable list for routing through WinPath, the cable routing program (developed by Corporate R&D) being used in PEM.

1. For the purpose of clarity, it may please be noted that the information given in regard to the cables to be routed through WinPath as per the system elaborated below is called "Cable List", while the term "Cable Schedule" applies to the cable list with routing information added after routing has been carried out.
2. The cable list shall be entered as an MS Excel file in the format as per enclosed template EXT_CAB_SCH_FORMAT.XLS. No blank lines, special characters, header, footer, lines, etc. shall be introduced in the file. No changes shall be made in the title line (first line) of the template.
3. The field properties shall be as under:
 - a. UNITCABLENO: A/N, up to sixteen (16) characters; each cable shall have its own unique, unduplicated cable number. In case this rule is violated, the cable cannot be taken up for routing.
 - b. FROM: A/N, up to sixty (60) characters; the "From" end equipment/ device description and location to be specified here. Information in excess of 60 characters will be truncated after 60 characters.
 - c. TO: A/N, up to sixty (60) characters; the "To" end equipment/ device description and location to be specified here. Information in excess of 60 characters will be truncated after 60 characters.
 - d. PURPOSE: A/N, up to sixty (60) characters; the purpose (i.e. power cable/ indication/ measurement, etc.) to be specified here. Information in excess of 60 characters will be truncated after 60 characters.
 - e. REMARKS: A/N, up to forty (40) characters; Any information pertinent to routing to be specified here (e.g., cable number of the cable redundant to the cable number being entered). Information in excess of 40 characters will be truncated after 40 characters.
 - f. CABLESIZE: A/N, 7 characters exactly as per the codes indicated below shall be specified here. The program cannot route cables described in any other way/ format.
 - g. PATHCABLENO: Field reserved for utilization by the program. User shall not enter any information here.
4. One list shall be prepared for each system/ equipment (i.e., separate and unique cable lists shall be prepared for each system).
5. The cables shall be described as per the scheme listed below:

A	NN	A	NNN
Cable	No. of cores	Cable code	Cable size
Voltage	(e.g. 01,03,3H, 07)	(See C below)	(e.g. 035,185,2.5, 0.5)
Code (see B below)			

(A) SYSTEM VOLTAGE CODES:

(ac) A = 11KV, B = 6.6KV, C = 3.3KV, D = 415V, E = 240V, F = 110V

(dc) G = 220V, H = 110V, J = 48V, K = +24V, L = -24V

(B) CABLE VOLTAGE CODES:

A = 11KV (Power cables)

1236331/2023/PS-PEM-MAX**Explanatory notes for filling up cable list for routing through WinPath, the cable routing program (developed by Corporate R&D) being used in PEM.**

- B = 6.6KV (Power cables)
 C = 3.3KV (Power cables)
 D = 1.1KV (LV & DC system power & control cables)
 E = 0.6KV (0.5 sq. mm. Control cables)

(C) CABLE CODES**PVC Copper**

- A = Armoured FRLS B = Armoured Non-FRLS
 C = unarmoured FRLS D = Unarmoured Non-FRLS

PVC Aluminium

- E = Armoured FRLS F = Armoured Non-FRLS
 G = unarmoured FRLS H = Unarmoured Non-FRLS

XLPE Copper

- J = Armoured FRLS K = Armoured Non-FRLS
 L = unarmoured FRLS M = Unarmoured Non-FRLS

XLPE Aluminium

- N = Armoured FRLS P = Armoured Non-FRLS
 Q = unarmoured FRLS R = Unarmoured Non-FRLS

- S = FIRE SURVIVAL CABLES
 T = TOUGH RUBBER SHEATH
 U = OVERALL SCREENED
 V = PAIRED OVERALL SCREENED (G-Type)
 W = PAIRED INDIVIDUAL SCREENED (F-type)
 Y = COMPENSATING CABLES
 I = PRE-FABRICATED CABLES
 Z = JELLY FILLED CABLES

6. Once a cable list has been given to PEM for routing, any subsequent changes required in the cable list (which may be in the form of addition of cables, deletion of cables, change of type or size of cable, etc.) must be informed as specific changes (as a separate file MS Excel of the same format as the original file) to the cable list given earlier if the cable list has been routed and cable schedule generated. The routing status of the cable list shall be got confirmed from PEM by the agency that has prepared the cable list before the changes are intimated. In case PEM confirms that the cable list in question has not been taken up for routing, and the revised cable list is acceptable, the same may be sent. Since cable routing through the program involves adding each cable list to the project cable schedule database, the original cable schedule shall not be furnished to PEM with revisions incorporated within.
7. For any assistance or clarifications, please contact sbnaithani@bhelpem.co.in.

SUB-VENDOR LIST

7	LT Switchgear - Floor mounted Fixed type indoor LT Switchgear Panel (ACDB / DCDB)	CATI				
					Schneider (formerly L&T)	Mumbai / Coimbatore/Ahmednagar
					C&S Electric	Noida/ Haridwar
					Schneider	Nasik
					Siemens	Kalwa
					Schneider	Vadodara
						#
	L1 KV LT Power Cables (Type- XLPE Insulated, PVC sheathed (incl FRLS)	CATI				
					Advance Cable	Bengaluru
					Apar Industries Ltd	Umbergaon
					Cords Cables	Bhiwadi
					CMI	Baddi
					Delton Cable Ltd	Faridabad
					Dynamic Cables	Jaipur
					Gemscabs Industries	Bhiwadi
					Gupta Power Cables	Khurda
					Havells India Ltd.	Alwar
					KEC International	Silvassa , Mysore
					KEI Industries	Bhiwadi
					Paramount Cable	Khushkhdera
					Polycab Wires Pvt. Ltd	Daman
					Ravin Cables	Pune
					Special Cables	Rudrapur
					Suyog Cables	Vadodara
					Thermocables	Hyderabad
					Tirupati Plastomatics	Jaipur
					Torrent Cable Ltd	Nadiad
					Universal Cable Ltd.	Satna
						#

ITEM CODE	ITEM/SERVICE DESCRIPTION	SL NO.	VENDOR CODE	VENDOR NAME	ADDRESS	PHONE	REMARKS
ES1	AC CONTACTORS	1	S01	SIEMENS	RC-IN I S NR DEL AREA, JIL BUILDING, TOWER-B, PLOT NO. 78, SECTOR 18, GURGAON-122015, INDIA	0124-2842000, 9873424331 amit.bhadauria@siemens.com	
	AC CONTACTORS	2	A35	GE-POWER	KAMAK TOWER, 3RD FLOOR, PLOT NO. 12-A, TVK INDUSTRIAL ESTATE, EKKADUTHANGAL, GUINDY, CHENNAI-600032	044-49681447	
	AC CONTACTORS	3	E1144	TELEMECHANIQUE/ SCHNEIDER ELECTRIC INDIA PVT. LTD.	9TH FLOOR, BLDG. NO. 10, TOWER-C, DLF CYBER CITY, PH-II, GURGAON-122002	0124-3940400	TAKEN OVER BY SCHNEIDER
	AC CONTACTORS	4	L01	L&T	32, SHIVAJI MARG, P.O. BOX- 6223, NEW DELHI-110015	011-41419554/59	
	AC CONTACTORS	5	B04	BCH	20/4, MATHURA ROAD, FARIDABAD, HARYANA-121006	0129-4293000	
ES2	AC LOAD BREAK SWITCH	1	A35	GE-POWER	KAMAK TOWER, 3RD FLOOR, PLOT NO. 12-A, TVK INDUSTRIAL ESTATE, EKKADUTHANGAL, GUINDY, CHENNAI-600032	044-49681447	
	AC LOAD BREAK SWITCH	2	L01	L&T	32, SHIVAJI MARG, P.O. BOX- 6223, NEW DELHI-110015	011-41419554/59	
	AC LOAD BREAK SWITCH	3	S01	SIEMENS	RC-IN I S NR DEL AREA, JIL BUILDING, TOWER-B, PLOT NO. 78, SECTOR 18, GURGAON-122015, INDIA	0124-2842000, 9873424331 amit.bhadauria@siemens.com	
	AC LOAD BREAK SWITCH	4	E1076	KAYCEE	KAYCEE INDUSTRIES LTD., C/O-CMS COMPUTERS LTD., 35A, REAR BLDG., KILOKARI, NEW DELHI-110014	Rajiv Sharma-9312004687	
	AC LOAD BREAK SWITCH	5	C01	C&S ELECTRIC LTD.	222, OKHLA IND. ESTATE, PH-III, NEW DELHI-110020	011-3088 7520-29	
ES3	AC MCCB	1	C01	C&S ELECTRIC LTD.	222, OKHLA IND. ESTATE, PH-III, NEW DELHI-110020	011-3088 7520-29	
	AC MCCB	2	S03	SCHNEIDER ELECTRIC INDIA PVT. LTD.	9TH FLOOR, BLDG. NO. 10, TOWER-C, DLF CYBER CITY, PH-II, GURGAON-122002	0124-3940400	
	AC MCCB	3	S01	SIEMENS	RC-IN I S NR DEL AREA, JIL BUILDING, TOWER-B, PLOT NO. 78, SECTOR 18, GURGAON-122015, INDIA	0124-2842000, 9873424331 amit.bhadauria@siemens.com	
	AC MCCB	4	A35	GE-POWER	KAMAK TOWER, 3RD FLOOR, PLOT NO. 12-A, TVK INDUSTRIAL ESTATE, EKKADUTHANGAL, GUINDY, CHENNAI-600032	044-49681447	
	AC MCCB	5	L01	L&T	32, SHIVAJI MARG, P.O. BOX- 6223, NEW DELHI-110015	011-41419554/59	
	AC MCCB	6	C02	CROMPTON GREAVES	RAIL TRANSPORTATION SYSTEMS,VANDANA BUILDING, 11, TOLSTOY MARG, TOLSTOY MARG, NEW DELHI, DL 110001	011 3041 6300	
ES7	AUXILIARY RELAYS	1	A24	ABB	14, MATHURA ROAD, FARIDABAD, HARYANA-121003	0129-2567580, 09871799449	
	AUXILIARY RELAYS	2	G01	ALSTOM LTD	A-7, SEC-65, NOIDA	0120-479 0000	
	AUXILIARY RELAYS	3	E1075	JYOTI LTD.	JYOTI LIMITED, E&CS DIVISION,3/15, BIDC, GORWA,VADODARA - 390 016, E-MAIL ID: ECS@JYOTI.COM	Ph. No. :+91-265-2281214 , Fax No. :+91-265-2281214	
	AUXILIARY RELAYS	4	E1099	OEN INDIA LTD	29/1479, VYTILLA, COCHIN - 682 019 KERALA, INDIA	Phone : +91 484 2301132, 2303709 Fax : +91 484 2302287, 2302221 sales@oenindia.com	
	AUXILIARY RELAYS	5	S01	SIEMENS	RC-IN I S NR DEL AREA, JIL BUILDING, TOWER-B, PLOT NO. 78, SECTOR 18, GURGAON-122015, INDIA	0124-2842000, 9873424331 amit.bhadauria@siemens.com	
ES8	BIMETAL RELAYS	1	L01	L&T	32, SHIVAJI MARG, P.O. BOX- 6223, NEW DELHI-110015	011-41419554/59	
	BIMETAL RELAYS	2	A35	GE-POWER	KAMAK TOWER, 3RD FLOOR, PLOT NO. 12-A, TVK INDUSTRIAL ESTATE, EKKADUTHANGAL, GUINDY, CHENNAI-600032	044-49681447	
	BIMETAL RELAYS	3	S01	SIEMENS	RC-IN I S NR DEL AREA, JIL BUILDING, TOWER-B, PLOT NO. 78, SECTOR 18, GURGAON-122015, INDIA	0124-2842000, 9873424331 amit.bhadauria@siemens.com	
	BIMETAL RELAYS	4	E1144	TELEMECHANIQUE/ SCHNEIDER ELECTRIC INDIA PVT. LTD.	9TH FLOOR, BLDG. NO. 10, TOWER-C, DLF CYBER CITY, PH-II, GURGAON-122002	0124-3940400	TAKEN OVER BY SCHNEIDER
ES9	BUCHHOLZ RELAY	1	G01	ALSTOM LTD	A-7, SEC-65, NOIDA	0120-479 0000	
	BUCHHOLZ RELAY	2	E1020	ATVUS INDUSTRIES	689, BLOCK 'O', NEW ALIPORE, CALCUTTA-700053	(91)-(33)-24001101 / 9885 sales@atvus.in	
	BUCHHOLZ RELAY	3	E1070	INSTRUMENTS & CONTROLS	146, GIDC IND.ESTATE,MAKARPURA, VADODRA-390010	0265-2642729	
ES10	CABLE CLAMPS & CABLE TIES	1	E1045	ELECTROMAC IND.CORPN.	27/28 AF,NEW EMPIRE IND.ESTT., R.KRISHNA MANDIR RD.JB NGR ,ANDHERI(E), MUMBAI-400059	91-22-28324829 / 66919034/ Mr. Devang Patel/ 91-9867074600 devang@electromacglands.com	
	CABLE CLAMPS & CABLE TIES	2	I01	INCAB	HARE STREET,KOLKATA,WEST BENGAL-700001	91-33-2480161/62/63/64 Fax : 91-33-2485766	
	CABLE CLAMPS & CABLE TIES	3	N05	NOVOFLEX MARKETING PVT. LTD.	RAIKVA' - 5TH FLOOR, UNIT-6 3A, RAM MOHAN MULLICK GARDEN LANE KOLKATA - 700 010	Phone: +91 33 2372 0088 Email: sales@novoflex.co.in, novoflexcal@vsnl.net	
	CABLE GLANDS	1	E1201	ALLIED TRADERS & EXPORTERS	C-124 A, SECTOR-2, NOIDA -201 301, UTTAR PRADESH, INDIA	Mr. Vijay Mohan Sood +(91)-(120)-2525694 +(91)-(120)-3052594 +(91)-(11)-23287156 vijay_mohansood@yahoo.com	
	CABLE GLANDS	2	E1017	ARUP ENGG & FOUNDARY WORKS	391/119,PRINCE ANWAR SHAH ROAD, CALCUTTA-700068	033 2473 0850	

ITEM CODE	ITEM/SERVICE DESCRIPTION	SL NO.	VENDOR CODE	VENDOR NAME	ADDRESS	PHONE	REMARKS
ES11	CABLE GLANDS	3	E1206	BALIGA LIGHTING EQPT.PVT.LTD.	63A,CP RAMASWAMY ROAD, ALWARPET,P.B.No 6910, CHENNAI-600018	44-24995505,22680990-4	
	CABLE GLANDS	4	E1036	COMMET BRASS PRODUCTS	NUTAN CHEMICAL COMPOUND, WALBHAT ROAD, GOREGAON, MUMBAI-400063	91-022-26852961/62/63 comet@vsnl.net	
	CABLE GLANDS	5	DW08	DOWELLS	M/S. DOWELLS ELECTRICALS 47/47A, SATGURU INDUSTRIAL ESTATE. OFF AAREY ROAD, GOREGAON (EAST). MUMBAI 400 063.	CEO : Mr. Jayantibhai S. Patel TEL: 022-32504770./022-29270876/ 022-29270878.	
	CABLE GLANDS	6	E1044	ELECTROMAC INDUSTRIES	27/28AF NEW EMPIRE IND.ESTT., R.KRISHNA MANDIR RD.JB NGR ,ANDHERI(E),MUMBAI-400059	91-22-28324829 / 66919034 devang@electromacglands.com	
	CABLE GLANDS	7	I01	INCAB	HARE STREET,KOLKATA,WEST BENGAL-700001	91-33-2480161/62/63/64 Fax : 91-33-2485766	
ES12	CABLE LUGS	1	E1040	DOWELLS	M/S. DOWELLS ELECTRICALS 47/47A, SATGURU INDUSTRIAL ESTATE. OFF AAREY ROAD, GOREGAON (EAST).	CEO : Mr. Jayantibhai S. Patel TEL: 022-32504770./022-29270876/	
	CABLE LUGS	2	E1149	UNIVERSAL MACHINES LTD.	4,B.B.D.BAG (EAST) 90,STEPHEN HOUSE,5TH FLR CALCUTTA-700001	033 2282 2540	
ES13	D.C. MCCB	1	C02	CROMPTON GREAVES	RAIL TRANSPORTATION SYSTEMS,VANDANA BUILDING, 11, TOLSTOY MARG, TOLSTOY MARG, NEW DELHI, DL 110001	011 3041 6300	
	D.C. MCCB	2	L01	L&T	32, SHIVAJI MARG, P.O. BOX- 6223, NEW DELHI-110015	011-41419554/59	
	D.C. MCCB	3	A35	GE-POWER	KAMAK TOWER, 3RD FLOOR, PLOT NO. 12-A, TVK INDUSTRIAL ESTATE, EKKADUTHANGAL,	044-49681447	
	D.C. MCCB	4	S01	SIEMENS	RC-IN I S NR DEL AREA, JIL BUILDING, TOWER-B, PLOT NO. 78, SECTOR 18, GURGAON-122015, INDIA	0124-2842000, 9873424331 amit.bhadauria@siemens.com	
ES14	EARTH LEAKAGE CB	1	L01	L&T	32, SHIVAJI MARG, P.O. BOX- 6223, NEW DELHI-110015	011-41419554/59	
	EARTH LEAKAGE CB	2	S01	SIEMENS	RC-IN I S NR DEL AREA, JIL BUILDING, TOWER-B, PLOT NO. 78, SECTOR 18, GURGAON-122015, INDIA	0124-2842000, 9873424331 amit.bhadauria@siemens.com	
	EARTH LEAKAGE CB	3	A35	GE-POWER	KAMAK TOWER, 3RD FLOOR, PLOT NO. 12-A, TVK INDUSTRIAL ESTATE, EKKADUTHANGAL, GUINDY, CHENNAI-600032	044-49681447	
	EARTH LEAKAGE CB	4	S03	SCHNEIDER ELECTRIC INDIA PVT. LTD.	9TH FLOOR, BLDG. NO. 10, TOWER-C, DLF CYBER CITY, PH-II, GURGAON-122002	0124-3940400	
	EARTH LEAKAGE CB	5	C01	C&S ELECTRIC LTD.	222, OKHLA IND. ESTATE, PH-III, NEW DELHI-110020	011-3088 7520-29	
	EARTH LEAKAGE CB	6	A24	ABB	14, MATHURA ROAD, FARIDABAD, HARYANA-121003	0129-2567580, 09871799449	
	EARTH LEAKAGE CB	7	E1068	INDO ASIAN	B-24, PHASE - II, NOIDA - 201305, U.P.	120-3042222	
	EARTH LEAKAGE CB	8	E1088	MDS SWITCHGEAR LTD	314-317SHAH NAHAR ESTATE	011 - 25793021	
	EARTH LEAKAGE CB	9	E1120	S&S POWER SWITCHGEAR LTD.	NEW NO. 67, OLD NO. 19, DR. RANGA ROAD, MYLAPORE, CHENNAI - 600004	044 - 24988056, 044 - 24988057, 044 - 24988058	
ES15	JELLY FILLED CABLES	1	D01	DELTON SALES LTD.	DELTON HOUSE 4801,BHARAT RAM ROAD,24DARYAGANJ N.DELHI-110002	3273905-8,3262517	
	JELLY FILLED CABLES	2	H01	HINDUSTAN CABLES	A-40 ASIAN GAMES VILLAGE RANJIT SINGH BLOCK NEW DELHI-110049	011-26493673	
	JELLY FILLED CABLES	3	E1096	TELELINK-NICCO	NICCO HOUSE 2,HARE STREET,CALCUTTA-700001	91-033-66285000	
	JELLY FILLED CABLES	4	E1151	USHA BELTRON LTD.	TATISILWAI , ranchi- 835105	91 651 415 897, 415 816	
ES16	GI CONDUITS	BIS APPROVED MAKE					
ES17	GI CONDUIT (EPOXY PAINTED)	BIS APPROVED MAKE					
ES18	FLEXIBLE CONDUITS (LEAD COATED)	1	P03	PLICA INDIA PVT. LTD.	V.P.AGARWAL MANAGING DIRECTOR, PLICA INDIA PVT. LTD. 149, MODEL TOWN EAST GHAZIABAD - 201009	M - 9810052131 / 0120-4563979 / 9810557567 Mail: agr@plicaindia.com	
ES19	FLEXIBLE CONDUIT (PVC COATED)	REPUTED MAKE					
ES20	DC CONTACTORS	1	S03	SCHNEIDER ELECTRIC INDIA PVT. LTD.	9TH FLOOR, BLDG. NO. 10, TOWER-C, DLF CYBER CITY, PH-II, GURGAON-122002	0124-3940400	
	DC CONTACTORS	2	E1030	BHEL (BHOPAL)	HEAVY ELECTRICAL PLANT		
	DC CONTACTORS	3	E1044	ELECTROMAC INDUSTRIES	27/28AF NEW EMPIRE IND.ESTT., R.KRISHNA MANDIR RD.JB NGR ,ANDHERI(E),MUMBAI-400059	91-22-28324829 / 66919034 devang@electromacglands.com	
	DC CONTACTORS	4	L01	L&T	32, SHIVAJI MARG, P.O. BOX- 6223, NEW DELHI-110015	011-41419554/59	
	DC CONTACTORS	5	S01	SIEMENS	RC-IN I S NR DEL AREA, JIL BUILDING, TOWER-B, PLOT NO. 78, SECTOR 18, GURGAON-122015, INDIA	0124-2842000, 9873424331 amit.bhadauria@siemens.com	
	DC CONTACTORS	6	E1144	TELEMECHANIQUE/ SCHNEIDER ELECTRIC INDIA PVT. LTD.	9TH FLOOR, BLDG. NO. 10, TOWER-C, DLF CYBER CITY, PH-II, GURGAON-122002	0124-3940400	TAKEN OVER BY SCHNEIDER
	DC CONTACTORS	7	A35	GE-POWER	KAMAK TOWER, 3RD FLOOR, PLOT NO. 12-A, TVK INDUSTRIAL ESTATE, EKKADUTHANGAL, GUINDY, CHENNAI-600032	044-49681447	
CONTROL SWITCHES/ SELECTOR SWITCH	CONTROL SWITCHES/ SELECTOR SWITCH	1	E1076	KAYCEE	KAYCEE INDUSTRIES LTD., C/O-CMS COMPUTERS LTD., 35A, REAR BLDG., KILOKARI, NEW DELHI-110014	Rajiv Sharma-9312004687	
	CONTROL SWITCHES/ SELECTOR SWITCH	2	A35	GE-POWER	KAMAK TOWER, 3RD FLOOR, PLOT NO. 12-A, TVK INDUSTRIAL ESTATE, EKKADUTHANGAL, GUINDY, CHENNAI-600032	044-49681447	

ITEM CODE	ITEM/SERVICE DESCRIPTION	SL NO.	VENDOR CODE	VENDOR NAME	ADDRESS	PHONE	REMARKS
ES21	CONTROL SWITCHES/ SELECTOR SWITCH	3	G01	ALSTOM LTD	A-7, SEC-65, NOIDA	0120-479000	
	CONTROL SWITCHES/ SELECTOR SWITCH	4	S03	SCHNEIDER ELECTRIC INDIA PVT. LTD.	9TH FLOOR, BLDG. NO. 10, TOWER-C, DLF CYBER CITY, PH-II, GURGAON-122002	0124-3940400	
	CONTROL SWITCHES/ SELECTOR SWITCH	5	SRC01	M/s Shrenik & Co.	39A/3, PANCHRATNA INDUSTRIAL ESTATE, SARKHEJ-BAVLA ROAD, CHANGODAR,		
	CONTROL SWITCHES/ SELECTOR SWITCH	6	RE05	RECOM PVT. LTD.	M/S RECOM PVT. LTD.,16A , 2ND FLOOR A, WING RAJ INDUSTRIAL COMPLEX, MILITARY	Mr. Chandrashekar Kamath (MD) : 09820249503	
ES22	CONTROL TRANSFORMER/ WINDING HEATING TRANSFORMER	1	E1009	AUTOMATIC ELECTRIC LTD.	96 AB LONAVLA INDUSTRIAL ESTATE NANGARGAON, LONAVLA-410401	Phone : +91 2114323665 Fax : +91 2114273482	
	CONTROL TRANSFORMER/ WINDING HEATING TRANSFORMER	2	E1066	INDCOIL	PLOT NO. A- 150/ 151, 23RD U ROAD, WAGLE ESTATE, THANE WEST, CST RD, FRIENDS COLONY, HALLOW PUL, KURLA WEST, MUMBAI, MAHARASHTRA 400070	Phone:022 2583 8305	
	CONTROL TRANSFORMER/ WINDING HEATING TRANSFORMER	3	K18	KAPPA ELECTRICALS	KAPPA ELECTRICALS, KAPPA CONSOLIDATED PVT. LTD., 14, CART TRACK ROAD, MADUVANKARAI, CHENNAI - 600 042, INDIA.	PHONE: +91 - 44 - 22454709, 22454516, 22450794, 22450795 FAX: +91 - 44 - 22351662, 22451693 E-MAIL: mira@kappaelectricals.com sales@kappaelectricals.com	
	CONTROL TRANSFORMER/ WINDING HEATING TRANSFORMER	4	E1082	LOGICSTAT	B-160, INDUSTRIAL AREA, C BLOCK RD, OKHLA I, OKHLA INDUSTRIAL AREA, NEW DELHI, DL 110020	011 2681 0032	
	CONTROL TRANSFORMER/ WINDING HEATING TRANSFORMER	5	E1106	PRECISE ELECTRICALS	47A-49A, CHAKALA ROAD ANDHERI(E), MUMBAI 99 MUMBAI, MAHARASHTRA, INDIA PIN-400 099	022-8323402 / 022-8216433	
	CONTROL TRANSFORMER/ WINDING HEATING TRANSFORMER	6	E1128	UNILEC ENGINEERS PVT. LTD.	PLOT NO: R-247, T.T.C. INDUSTRIAL AREA, M.I.D.C , RABALE, NAVI MUMBAI- 400 701 INDIA	+91-22- 27607787 / 27607927 +91-22- 27607997	
	CONTROL TRANSFORMER/ WINDING HEATING TRANSFORMER	7	NK09	M/s Newtek Electricals	M-90, M.I.D.C, Waluj, Aurangabad 431136, Maharashtra, India	Tel/Fax: +91 240 2551555 E-mail: mkt.north@newtekelectricals.co m, sales@newtekelectricals.com Mr Sanjeev Aggarwal (9958897890)	FOR CONTROL TRANSFORMER ONLY
ES23	LT- CURRENT TRANSFORMER	1	S01	SIEMENS	RC-IN I S NR DEL AREA, JIL BUILDING, TOWER- B, PLOT NO. 78, SECTOR 18, GURGAON- 122015, INDIA	0124-2842000, 9873424331 amit.bhadauria@siemens.com	
	LT- CURRENT TRANSFORMER	2	E1009	AUTOMATIC ELECTRIC LTD.	96 AB LONAVLA INDUSTRIAL ESTATE NANGARGAON, LONAVLA-410401	Phone : +91 2114323665 Fax : +91 2114273482	
	LT- CURRENT TRANSFORMER	3	E1066	INDCOIL	PLOT NO. A- 150/ 151, 23RD U ROAD, WAGLE ESTATE, THANE WEST, CST RD, FRIENDS COLONY, HALLOW PUL, KURLA WEST, MUMBAI, MAHARASHTRA 400070	Phone:022 2583 8305	
	LT- CURRENT TRANSFORMER	4	K18	KAPPA ELECTRICALS	KAPPA ELECTRICALS, KAPPA CONSOLIDATED PVT. LTD., SOUTHERN ELECTRIKS 14, CART TRACK ROAD, MADUVANKARAI, CHENNAI - 600 042, INDIA.	PHONE: +91 - 44 - 22454709, 22454516, 22450794, 22450795 FAX: +91 - 44 - 22351662, 22451693 E-MAIL: mira@kappaelectricals.com sales@kappaelectricals.com	
	LT- CURRENT TRANSFORMER	5	E1104	PRAGATI ELECTRICALS	280/3,II POKHRAN RD	5341779,5427041	
	LT- CURRENT TRANSFORMER	6	E1106	PRECISE ELECTRICALS	47A-49A, CHAKALA ROAD ANDHERI(E), MUMBAI 99 MUMBAI, MAHARASHTRA, INDIA PIN-400 099	022-8323402 / 022-8216433	
	LT- CURRENT TRANSFORMER	7	E1128	SILKAANS ELECT.MFG.CO.PVT.LTD	PLOT NO: R-247, T.T.C. INDUSTRIAL AREA, M.I.D.C , RABALE, NAVI MUMBAI- 400 701 INDIA	+91-22- 27607787 / 27607927 +91-22- 27607997	
	LT- CURRENT TRANSFORMER	8	E1111	PRAYOG ELECTRICALS PVT. LTD.	GROUND FLOOR, THAKORE INDUSTRIAL COMPUND, STATION ROAD, VIDYA VIHAR (W), NATHANI ROAD , OPP. AMIBIKA TEMPLE,MUMBAI Mumbai - 400086, Maharashtra, India	91-22-25164288/25133146 Mr. P. U. PATWARDHAN (MANAGING DIRECTOR)	
	LT- CURRENT TRANSFORMER	9	C01	C&S ELECTRIC LTD.	222, OKHLA IND. ESTATE, PH-III, NEW DELHI- 110020	011-3088 7520-29	
	LT- CURRENT TRANSFORMER	10	NK09	M/s Newtek Electricals	M-90, M.I.D.C, Waluj, Aurangabad 431136, Maharashtra, India	Tel/Fax: +91 240 2551555 E-mail: mkt.north@newtekelectricals.co m, sales@newtekelectricals.com Mr Sanjeev Aggarwal (9958897890)	
	LT- POTENTIAL TRANSFORMER	1	S01	SIEMENS	RC-IN I S NR DEL AREA, JIL BUILDING, TOWER- B, PLOT NO. 78, SECTOR 18, GURGAON- 122015, INDIA	0124-2842000, 9873424331 amit.bhadauria@siemens.com	
	LT- POTENTIAL TRANSFORMER	2	E1009	AUTOMATIC ELECTRIC LTD.	96 AB LONAVLA INDUSTRIAL ESTATE NANGARGAON, LONAVLA-410401	Phone : +91 2114323665 Fax : +91 2114273482	
	LT- POTENTIAL TRANSFORMER	3	E1066	INDCOIL	PLOT NO. A- 150/ 151, 23RD U ROAD, WAGLE ESTATE, THANE WEST, CST RD, FRIENDS COLONY, HALLOW PUL, KURLA WEST, MUMBAI, MAHARASHTRA 400070	Phone:022 2583 8305	

SUB-VENDOR LIST

ITEM CODE	ITEM/SERVICE DESCRIPTION	SL NO.	VENDOR CODE	VENDOR NAME	ADDRESS	PHONE	REMARKS
ES24	LT- POTENTIAL TRANSFORMER	4	K18	KAPPA ELECTRICALS	KAPPA ELECTRICALS, KAPPA CONSOLIDATED PVT. LTD., SOUTHERN ELECTRIKS 14, CART TRACK ROAD, MADUVANKARAI, CHENNAI - 600 042, INDIA.	PHONE: +91 - 44 - 22454709, 22454516, 22450794, 22450795 FAX: +91 - 44 - 22351662, 22451693 E-MAIL: mira@kappaelectricals.com sales@kappaelectricals.com	
	LT- POTENTIAL TRANSFORMER	5	E1104	PRAGATI ELECTRICALS	280/3,II POKHRAN RD	5341779,5427041	
	LT- POTENTIAL TRANSFORMER	6	E1106	PRECISE ELECTRICALS	47A-49A,CHAKALA ROAD ANDHERI(E),MUMBAI- 99 MUMBAI, MAHARASHTRA, INDIA PIN-400 099	022-8323402 / 022-8216433	
	LT- POTENTIAL TRANSFORMER	7	E1128	SILKAANS ELECT.MFG.CO.PVT.LTD	PLOT NO: R-247, T.T.C. INDUSTRIAL AREA, M.I.D.C , RABALE, NAVI MUMBAI- 400 701 INDIA	+91-22- 27607787 / 27607927 +91-22- 27607997	
	LT- POTENTIAL TRANSFORMER	8	E1111	PRAYOG ELECTRICALS PVT. LTD.	GROUND FLOOR, THAKORE INDUSTRIAL COMPUND, STATION ROAD, VIDYA VIHAR (W), NATHANI ROAD , OPP. AMIBIKA TEMPLE,MUMBAI Mumbai - 400086, Maharashtra, India	91-22-25164288/25133146 Mr. P. U. PATWARDHAN (MANAGING DIRECTOR)	
LT- POTENTIAL TRANSFORMER	9	NK09	M/s Newtek Electricals	M-90, M.I.D.C, Waluj, Aurangabad 431136, Maharashtra, India	Tel/Fax: +91 240 2551555 E-mail: mkt.north@newtekelectricals.co m, sales@newtekelectricals.com Mr Sanjeev Aggarwal (9958897890)		
ES25	DC SWITCH	1	A35	GE-POWER	KAMAK TOWER, 3RD FLOOR, PLOT NO. 12-A, TVK INDUSTRIAL ESTATE, EKKADUTHANGAL, GUINDY, CHENNAI-600032	044-49681447	
	DC SWITCH	2	E1076	KAYCEE	KAYCEE INDUSTRIES LTD., C/O-CMS COMPUTERS LTD., 35A, REAR BLDG., KILOKARI, NEW DELHI-110014	Rajiv Sharma-9312004687	
	DC SWITCH	3	S01	SIEMENS	RC-IN I S NR DEL AREA, JIL BUILDING, TOWER- B, PLOT NO. 78, SECTOR 18, GURGAON- 122015, INDIA	0124-2842000, 9873424331 amit.bhadauria@siemens.com	
ES26	DISTRIBUTION BOX	1	SR01	M/S SHRENIK & CO.	39A/3, PANCHRATNA INDUSTRIAL ESTATE, SARKHEJ-BAVLA ROAD, CHANGODAR, AHMEDABAD – 382 213		
ES27	EMER. PORTABLE LTG. SET	1	B05	BAJAJ ELECTRICALS	BAJAJ ELECTRICALS LTD. ENGINEERING & PROJECTS BU (NORTH) 3rd FLOOR, GULMOHARHOUSE, COMMUNITY CENTRE 161/B-4, GAUTAM NAGAR, YUSUF SARAI NEW DELHI – 110049	CONTACT PERSON : Mr. S. SREEMANY. SR. MANAGER (PROJECTS) CONTACT DETAILS : (+91) 9871025705. MAIL ID : srabans@bajajelectricals.com;	
	EMER. PORTABLE LTG. SET	2	B05	BAJAJ ELECTRICALS	BAJAJ ELECTRICALS LTD. ENGINEERING & PROJECTS BU (NORTH) 3rd FLOOR, GULMOHARHOUSE, COMMUNITY CENTRE 161/B-4, GAUTAM NAGAR, YUSUF SARAI NEW DELHI – 110049	SREEMANY. SR. MANAGER (PROJECTS) CONTACT DETAILS : (+91) 9871025705. MAIL ID : srabans@bajajelectricals.com;	
ES28	FUSE BASE	1	E1068	INDO ASIAN	B-24, PHASE - II , NOIDA - 201305, U.P.	120-3042222	
	FUSE BASE	2	G01	GE-POWER	KAMAK TOWER, 3RD FLOOR, PLOT NO. 12-A, TVK INDUSTRIAL ESTATE, EKKADUTHANGAL, GUINDY, CHENNAI-600032	044-49681447	
	FUSE BASE	3	L01	L&T	32, SHIVAJI MARG, P.O. BOX- 6223, NEW DELHI- 110015	011-41419554/59	
	FUSE BASE	4	CD1	C&S ELECTRIC LTD.	222, OKHLA IND. ESTATE, PH-III, NEW DELHI- 110020	011-3088 7520-29	
	FUSE BASE	5	S01	SIEMENS	RC-IN I S NR DEL AREA, JIL BUILDING, TOWER- B, PLOT NO. 78, SECTOR 18, GURGAON- 122015, INDIA	0124-2842000, 9873424331 ;amit.bhadauria@siemens.com	
	FUSE BASE	6	A24	ABB	14, MATHURA ROAD, FARIDABAD, HARYANA- 121003	0129-2567580, 09871799449	
	FUSE BASE	7	S02	SPACEAGE SWITCHGEARS LTD.	68 & 13-A INDUSTRIAL DEVELOPMENT COLONY, MEHRAULI ROAD GURGAON, HARYANA-122001	0124-2302711, 4085091	
	FUSE BASE	8	S03	SCHNEIDER ELECTRIC INDIA PVT. LTD.	9TH FLOOR, BLDG. NO. 10, TOWER-C, DLF CYBER CITY, PH-II, GURGAON-122002	0124-3940400	
	FUSE BASE	9	G01	ALSTOM LTD	A-7, SEC-65, NOIDA	0120-479 0000	
	FUSE BASE	10	E1050	ESSEN DEINKI	FLAT NO. 502, SKYLINE HOUSE 85, NEHRU PLACE NEW DELHI	011-26217060	
ES29	HRC FUSES	1	E1068	INDO ASIAN	B-24, PHASE - II , NOIDA - 201305, U.P.	120-3042222	
	HRC FUSES	2	G01	GE-POWER	KAMAK TOWER, 3RD FLOOR, PLOT NO. 12-A, TVK INDUSTRIAL ESTATE, EKKADUTHANGAL, GUINDY, CHENNAI-600032	044-49681447	
	HRC FUSES	3	L01	L&T	32, SHIVAJI MARG, P.O. BOX- 6223, NEW DELHI- 110015	011-41419554/59	
	HRC FUSES	4	CD1	C&S ELECTRIC LTD.	222, OKHLA IND. ESTATE, PH-III, NEW DELHI- 110020	011-3088 7520-29	
	HRC FUSES	5	S01	SIEMENS	RC-IN I S NR DEL AREA, JIL BUILDING, TOWER- B, PLOT NO. 78, SECTOR 18, GURGAON- 122015, INDIA	0124-2842000, 9873424331 ;amit.bhadauria@siemens.com	
	HRC FUSES	6	A24	ABB	14, MATHURA ROAD, FARIDABAD, HARYANA- 121003	0129-2567580, 09871799449	

SUB-VENDOR LIST

1236331/2023/PS-PEM-MAX

ITEM CODE	ITEM/SERVICE DESCRIPTION	SL NO.	VENDOR CODE	VENDOR NAME	ADDRESS	PHONE	REMARKS
	HRC FUSES	7	S02	SPACEAGE SWITCHGEARS LTD.	68 & 13-A INDUSTRIAL DEVELOPMENT COLONY, MEHRAULI ROAD GURGAON, HARYANA-122001	0124-2302711, 4085091	
	HRC FUSES	8	S03	SCHNEIDER ELECTRIC INDIA PVT. LTD.	9TH FLOOR, BLDG. NO. 10, TOWER-C, DLF CYBER CITY, PH-II, GURGAON-122002	0124-3940400	
	HRC FUSES	9	G01	ALSTOM LTD	A-7, SEC-65, NOIDA	0120-479 0000	
	HRC FUSES	10	E1050	ESSEN DEINKI	FLAT NO. 502, SKYLINE HOUSE 85, NEHRU PLACE NEW DELHI	011-26217060	
ES30	GALVANISING	1		Jenco Industrial Corporation	Chincholi Bunder Khkar Road Near Link Road Devruwadi Malad (W) Mumbai 400064		
	GALVANISING	2		National Galvanizing Company	66, Barrackpore Kamarhatt Trunck Road Calcutta-700058		
	GALVANISING	3		Sigma Galvanising Pvt. Ltd.	Plot No. C-169, TTC, MIDC Ind Area Navin Mumbai-400705	8725402,8725765	
	GALVANISING	4		B.P. Projects PVT LTD	167A, Vivekananda Road Kolkata-700006	033 2553 1254	
	GALVANISING	5		Standard Galvanisers	Makardah Road, Kabara Para, Bankra, Howarah -711403	28756318/28741986/28725402/28725765	
	GALVANISING	6		Steel Products	National Highway No. 6, Chamrail, Kona, Howrah-711114		
	GALVANISING	7		Unitech Fabricators & Engineers Pvt. Ltd.	Village- Ajab Nagar, P.O. -Molla Simila, P.S. Singur, Dist - Hoogly, Pin-712223	022 -27686606/ 1907	
	GALVANISING	8		Shivam Engineers & Fabricators	A0-282-284, Industrial Area, South Side of G.T. Road, Ghaziabad, U.P.		
	GALVANISING	9		B.G. Shirke Construction Technology Pvt. Ltd	72-76, Mundhawa, Pune - 401 036		
	GALVANISING	10		Galbro Ispat Galvanizers Pvt. Ltd.	GUT 11 AND 12, OPP. Kudus Steel,Rolling Mill, Wada, Thane , Mumbai		
	GALVANISING	11		Eros Metals	G-97, MIDC, Bhutibori , Naggpur		
	GALVANISING	12		Industrial Perforation (India) Pvt. Ltd.	Ganganagr, Katakhal, Kolkata-700132		
	GALVANISING	13		Indmark Formtech Pvt. Ltd.	Phase - 3, E - 11 / 1, M. I. D. C., Chakan, Pune - 410 501, Maharashtra, India.		
	GALVANISING	14		Namdhari Industrial Traders Pvt. Ltd.	Village Latton Dana, Chandigarh Road, Ludhiana		
	GALVANISING	15		Neha Galvaniser	Jalan Industrial Estate, Gate No-1, 1st Right Choise Lane, Near N.G-6, Jangalpur, PO Domjur Howrah - 700071, West Bengal, India		
	GALVANISING	16		Patny Systems (P) Ltd.	Unit-IV, Sy No. -228/9, Plot No. 6, IP Kuchavaram, Toopran(M) Dist.- Medak, Telegana - 502336		
	GALVANISING	17		Parmar Metal Company	Survey No.207,Veraval (Shapar) Dist. Rajkot, India.		
	GALVANISING	18		Rukmani Electrical & Components Pvt Ltd	Urla Industrial Area, Urla Sarora Road, Raipur- 493 221 (Chhattisgarh)		
	GALVANISING	18		Rukmani Fab & Gal Pvt Ltd	Shankharidaha Baniyarah, Jalan Industrial Complex, Gate no.3, Lane no. 4, Domjur, Howrah , W.B. - 711411		
	GALVANISING	19		DMP Projects Pvt.Ltd.	Dulagarh Industrial Park , PS-Sankrail , Howrah -711302		
	GALVANISING	20		Vinfab Engineers India Private Limited	Gut no. 224/1 &2 Bhiwandi Wada State Highway, Village khupri, Dist. Thane, Maharashtra -421303		
	GALVANISING	21		Saral Projects & Processors	B-1, Industrial Area, Site-II, Amawan Road Rae Bareli		
	GALVANISING	22		Brahampuri Steels Limite	172 (F) Industrial Area, Jhotwara, Jaipur-302013		
	GALVANISING	23		Indiana Gratings PVT. LTD	F-5, MIDC Jejuri, Pune-412 303		
GALVANISING	24	AT08	M/s AVAIDS TECHNOVATORS PVT. LTD.	131, MATSYA INDUSTRIAL AREA, ALWAR RAJASTHAN			
	GI WIRE & FLAT	1	I039	INDUSTRIAL PERFORATION (I) PVT.LTD.	MR. A. K. SAHA 327, R.N.GUHA ROAD, DUM DUM KOLKATA-West Bengal-India Phone-9830241788 Pincode : 700028 Email : ipipl@cal2.vsnl.net.in	011 2737 3579	
	GI WIRE & FLAT	2	I070	INDIA ELECTRICALS SYNDICATE	Mr. Suresh Kumar Agarwal 55, Ezra Street, Kolkata-West Bengal-India Phone- 033-22354047 Pincode : 700001 Email : cabletray@vsnl.com	022-28511704	
	GI WIRE & FLAT	3	I072	INDMARK FORMTECH PVT. LTD.	Mr. Narendra R. Meher J Block, Plot No.-375, MIDC BHOSARI PUNE-MAHARASHTRA-INDIA Phone- 020-27130546 Pincode : 411026 Email : indmarkformtech@vsnl.net		
	GI WIRE & FLAT	4	P039	PREMIER POWER PRODUCTS (CAL) PVT. LTD.	Chatterjee International Centre, 33A, Jawaharlal Nehru Road, 6th Floor, Suit No. - 11A, Kolkata,-West Bengal-India Phone-9331008739 Pincode : 700071 Email : hemantdaga@dagaventures.com		
	GI WIRE & FLAT	5	P050	PATNY SYSTEMS (P) LTD	PATNY PLAZA 160, SARDAR PATEL ROAD SEUNDRABAD SECUNDRABAD-TELANGANA-INDIA Phone- 040-27902451 Pincode : 500003 Email : mr.mkt@patnysystems.com		

SUB-VENDOR LIST

ITEM CODE	ITEM/SERVICE DESCRIPTION	SL NO.	VENDOR CODE	VENDOR NAME	ADDRESS	PHONE	REMARKS
ES31	GI WIRE & FLAT	6	P079	PASSIVE INFRA PROJECTS PVT. LTD.	MR. VARUN AGRAWAL 182, VAISHALI, PITAMPURA Delhi-DELHI-INDIA Phone- 9871183059 Pincode : 110088 Email : ATANU.SAHA@PASSIVEINFRA.COM		
	GI WIRE & FLAT	7	R036	RUKMANI ELECTRICAL & COMPONENTS PVT LTD	11A, MAHARISHI DEBENDRA ROAD 1ST FL, ROOM NO.4 KOLKATA-WEST BENGAL-INDIA Phone- Pincode : 700007 Email : maruthikabra@gmail.com		
	GI WIRE & FLAT	8	R037	RATAN PROJECTS & ENGINEERING CO. PVT.LTD.	MR. G.D. SINGHEE/MR. MAHESH SINGHEE 26, P.K. TAGORE STREET, MAIN BUILDING KOLKATA-WEST BENGAL-INDIA Phone- 9830177331 Pincode : 700006 Email : mahesh@ratans.com		
	GI WIRE & FLAT	9	R041	RABI ENGINEERING WORKS PVT. LTD.	MR. TAPAN KUMAR SEN/MR. SIDDHARTHA 327, R.N. GUHA ROAD, DUM DUM, KOLKATA-WEST BENGAL-INDIA Phone- 9748753002 Pincode : 700028 Email : rabiengineering@gmail.com		
	GI WIRE & FLAT	10	R200	RAJASTHAN METAL SMELTING CO.	Mr. R. K. Tibrewala D-80, Road No. 7, V.K.I.A., Jaipur-Rajasthan-India Phone- 0141-2332269 Pincode : 302013 Email : info@rmscoindia.com		
	GI WIRE & FLAT	11	S210	SARAL INDUSTRIES	Mr. Y.K. Gupta L-1, L-2, Industrial Area-1 Sultanpur Road Rae Bareilly-Uttar Pradesh-India Phone- 0535-2702474 Pincode : 229010 Email : saralindustries@gmail.com		
	GI WIRE & FLAT	12		PARCO Engineers Pvt. Ltd.	401, skyline Epitom Building ,Near to Jolly Gym Khana, Kirol Road , Vidhyavihar, MH 400086 India		
	GI WIRE & FLAT	13	U019	UNITECH FABRICATORS and ENGINEERS PVT LTD	INDRAPRASHTHA APARTMENT 24 , M.B.RAOD, BIRATI KALABAGAN KOLKATA KOLKATA-WEST BENGAL-INDIA Phone- Pincode : 700051 Email : ufepl@vsnl.net; ufepl@rediffmail.com	022 - 26230814	
ES32	HIGH MAST	1	B05	BAJAJ ELECTRICALS	BAJAJ ELECTRICALS LTD. ENGINEERING & PROJECTS BU (NORTH) 3rd FLOOR, GULMOHARHOUSE, COMMUNITY CENTRE 161/B-4, GAUTAM NAGAR, YUSUF SARAI NEW DELHI - 110049	SREEMANY. SR. MANAGER (PROJECTS) CONTACT DETAILS : (+91) 9871025705. MAIL ID :rabans@bajajelectricals.com;	
	HIGH MAST	2	TL01	M/S TRANSRAIL LIGHTING LIMITED (TLL)	M/S TRANSRAIL LIGHTING LIMITED (TLL), GAMMON INDIA LIMITED 2ND FLOOR , CENTRIC PLAZA, PLOT NO.8 POCKET-4, SECTOR-11 DWARKA , NEW DELHI -110075	hemant.jain@transrailttd.com'	
ES33	IND.POWER & WLDG SOCKETS	1	C02	CROMPTON GREAVES	3RD FLOOR, EXPRESS BUILDING,9-10, BAHADUR SHAH ZAFAR MARG, NEAR ITO CROSSING,NEW DELHI-110002, INDIA	91 11 23460700 - 999 *Sunil.Das@cgglobal.com	
	IND.POWER & WLDG SOCKETS	2	E1207	CYCLE ELECTRIC DEVICE & SERV.CO.	: A-3, NEAR ANTHEM BIOSCIENCE, KSSIDC INDUSTRIAL AREA, BOMMASANDRA, BOMMASANDRA INDUSTRIAL AREA, BANGALORE, KARNATAKA 560099	Mr. H.Jaishanker +919845039081, 080 - 27833102, 080 - 27833103 : +91 80 41460985 *cycloelectric@gmail.com	
	IND.POWER & WLDG SOCKETS	3	B04	BCH	20/4, MATHURA ROAD, FARIDABAD - 121006, HARYANA, INDIA	0(129)-4063000, 9015800189(Ramesh Giri) *ramesh.giri@bchindia.com	
	IND.POWER & WLDG SOCKETS	4	B02	BEST & CROMPTON	Best & Crompton Engineering Ltd	Ph : +91 44 4551 4724 , MRKT	BEST &
	IND.POWER & WLDG SOCKETS	5	A03	AJMERA INDUSTRIES & ENGG. WORKS	AJMERA INDL. AND ENGG. WORKS. AJMERA HOUSE, A-61 / KHAIRANE MIDC. , TTC INDL. AREA, NAVI MUMBAI - 400705.	Tel : 022 27620299 / 97 / 96 mail@ajmera.net	
ES34	INTERPOSING RELAY	1	A24	ABB	14, MATHURA ROAD, FARIDABAD, HARYANA-121003	0129-2567580, 09871799449	
	INTERPOSING RELAY	2	G01	ALSTOM LTD	A-7, SEC-65, NOIDA	0120-479 0000	
	INTERPOSING RELAY	3	E1075	JYOTI LTD.	JYOTI LIMITED, E&CS DIVISION,3/15, BIDC, GORWA,VADODARA - 390 016, E-MAIL ID: ECS@JYOTI.COM	Ph. No.:+91-265-2281214 , Fax No.:+91-265-2281214	
	INTERPOSING RELAY	4	E1099	OEN INDIA LTD	29/1479, VYTILLA, COCHIN - 682 019 KERALA, INDIA	Phone : +91 484 2301132, 2303709 Fax : +91 484 2302287, 2302221 sales@oenindia.com	
	INTERPOSING RELAY	5	S01	SIEMENS	RC-IN I S NR DEL AREA, JIL BUILDING, TOWER-B, PLOT NO. 78, SECTOR 18, GURGAON-122015, INDIA	0124-2842000, 9873424331 amit.bhadauria@siemens.com	
ES35	INDICATING LAMPS	1	B04	BCH	20/4, MATHURA ROAD, FARIDABAD, HARYANA-121006	0129-4293000	
	INDICATING LAMPS	2	C01	C&S ELECTRIC LTD.	222, OKHLA IND. ESTATE, PH-III, NEW DELHI-110020	6832259,6918834-37	
	INDICATING LAMPS	3	E1050	ESSEN DEINKI	FLAT NO. 502, SKYLINE HOUSE 85, NEHRU PLACE NEW DELHI	011-26217060	
	INDICATING LAMPS	4	E1153	VAISHNO(HOTLINE SWGR.& CONTROL)	G-19, SECTOR - 11, NOIDA - 201301, UTTAR PRADESH, INDIA	8377805157 9818338922	
	INDICATING LAMPS	5	A35	GE-POWER	KAMAK TOWER, 3RD FLOOR, PLOT NO. 12-A, TVK INDUSTRIAL ESTATE, EKKADUTHANGAL, GUINDY, CHENNAI-600032	9818338922	
	INDICATING LAMPS	6	S01	SIEMENS	RC-IN I S NR DEL AREA, JIL BUILDING, TOWER-B, PLOT NO. 78, SECTOR 18, GURGAON-122015, INDIA	0124-2842000, 9873424331 amit.bhadauria@siemens.com	
	INDICATING LAMPS	7	S03	SCHNEIDER ELECTRIC INDIA PVT. LTD.	9TH FLOOR, BLDG. NO. 10, TOWER-C, DLF CYBER CITY, PH-II, GURGAON-122002	0124-3940400	
	JUNCTION BOXES (NON FLAME PROOF)	1	J01	JASPER ENGINEERS PVT. LTD.	A-23, SECTOR - 8, NOIDA-201301	0120-4033520/533	

ITEM CODE	ITEM/SERVICE DESCRIPTION	SL NO.	VENDOR CODE	VENDOR NAME	ADDRESS	PHONE	REMARKS
ES36	JUNCTION BOXES (NON FLAME PROOF)	2	EC05	Electro Controls & Devices	M/S ELECTRO CONTROLS & DEVICES, F-41, SITE-C, SURAIPUR INDUSTRIAL AREA GREATER NOIDA, UTTAR PRADESH :201308	Mr. Sanjay Sharma (Chief Promoter) 0120-2569487, 2560100,2560300	
	JUNCTION BOXES (NON FLAME PROOF)	3	SRC01	M/s Shrenik & Co.	39A/3, PANCHRATNA INDUSTRIAL ESTATE, SARKHEJ-BAVLA ROAD, CHANGODAR, AHMEDABAD – 382 213	020-026708100	
	JUNCTION BOXES (NON FLAME PROOF)	4	PME-01	M/s PHOENIX MECANO LTD.,	388 BHARE, TALUKA MULSHI, POST GHOTAWADE, PIRANGOOT, INDUSTRIAL AREA, PUNE-412115	Awasthi(09971119006) Tel: ++91 20 6674 5103, Mobile: +91 90499 95985, Fax: ++91 20 6674 5126	
	JUNCTION BOXES (NON FLAME PROOF)	5	ACE01	Adroit Control Engineers Pvt.Ltd.	M/S ADROIT CONTROL ENGINEERS PVT.LTD. PLOT-3, KRISHNA INDL AREA, SECTOR-25 FARIDABAD – 121004	011-47600700, 0129-4251400	
	JUNCTION BOXES (NON FLAME PROOF)	6	PME-01	M/s PHOENIX MECANO LTD.,	388 BHARE, TALUKA MULSHI, POST GHOTAWADE, PIRANGOOT, INDUSTRIAL AREA, PUNE-412115	Awasthi(09971119006) Tel: ++91 20 6674 5103, Mobile: +91 90499 95985, Fax: ++91 20 6674 5126 contact person : Vishwa bandhu E-mail:d.gupta@pmipl-online.com ;admin@pmipl-online.com	
	JUNCTION BOXES (NON FLAME PROOF)	7	MK01	MIKA ENGINEERS	BRANCH OFFICE : 'D'-101, DHEERAJ HERITAGE RESIDENCY II, SHASTRI NAGAR, SANTACRUZ (W), MUMBAI 400 054.	Director : Mr. Asgar Karimi Email: asgar@mikaengineers.com E-mail : mika@mtnl.net.inTelfax : 022-26610081/82/83/84Tel : 02527-249066/70 Cell : 099230 74373	TYPE-S ONLY
	JUNCTION BOXES (NON FLAME PROOF)	8	PME-01	M/s PHOENIX MECANO LTD.,	388 BHARE, TALUKA MULSHI, POST GHOTAWADE, PIRANGOOT, INDUSTRIAL AREA, PUNE-412115	TEL- +912066745000 Awasthi(09971119006) Tel: ++91 20 6674 5103, Mobile: +91 90499 95985, Fax: ++91 20 6674 5126 contact person : Vishwa bandhu E-mail:d.gupta@pmipl-online.com ;admin@pmipl-online.com	
	JUNCTION BOXES (NON FLAME PROOF)	9	B05	BAJAJ ELECTRICALS	BAJAJ ELECTRICALS LTD. ENGINEERING & PROJECTS BU (NORTH) 3rd FLOOR, GULMOHARHOUSE, COMMUNITY CENTRE 161/B-4, GAUTAM NAGAR, YUSUF SARAI NEW DELHI – 110049	CONTACT PERSON : Mr. S. SREEMANY. SR. MANAGER (PROJECTS) CONTACT DETAILS : (+91) 9871025705. MAIL ID : srbans@bajajelectricals.com;	
	JUNCTION BOXES (NON FLAME PROOF)	10	A03	AJEMERA INDUSTRIES & ENGG. WORKS	AJEMERA INDL AND ENGG. WORKS. AJEMERA HOUSE, A-61 / KHAIRANE MIDC. , TTC INDL AREA, NAVI MUMBAI – 400705.	Tel : 022 27620299 / 97 / 96 mail@ajmerna.net	
	JUNCTION BOXES (NON FLAME PROOF)	11	SB02	S.B. ELECTRICAL ENGINEERING CORPORATION	03, SARDAR GRIHA BUILDING, LOHAR CHAWAL, MUMBAI-400002	022- 22069831; 022-66637259	
	JUNCTION BOXES (NON FLAME PROOF)	12	RT13	RITTAL INDIA PVT. LTD.	Espire Building ,Level -1 A-41, Mohan Co-Operative Industrial Estate ,Mathura Road, New Delhi -110044	Amit Bansal Phone: 011-42004000, D: 011-42004033 - Mobile: +91 971772245 - mailto:amit.b@rittal-india.com www.rittal-india.com	
	JUNCTION BOXES (NON FLAME PROOF)	13	HP08	HPL ELECTRIC AND POWER LTD.	Works Address: Village Shavella, PO:Jabli, Teh- Kasauli, Dist-Solan, Himachal Pradesh-173209	Mr. Ashwani Kumar mailto:'ashwani@hplindia.com' M:9971127370	
	ES37	JUNCTION BOXES (FLAME PROOF)	1	SS01	SUDHIR SWITCHGEAR	305/6, APEEJAY HOUSE, 130, BOMBAY SAMACHAR MARG, MUMBAI - 400 023. INDIA	Telephone Nos. : 40460000 (100 lines) Fax Nos. : ++91-22-22049381 Email : md@sudhirsritchgear.com ; works@sudhirsritchgear.com ;scud@vsnl.com
	LIGHTING DISTRIBUTION BOARDS	1	E1007	ADVANCE ENGG. COMPANY	38,SETHI IND. ESTATE 10/E,SUREN RD,ANDHERI MUMBAI-400097	91 - 22 - 24360086	
	LIGHTING DISTRIBUTION BOARDS	2	STRG01	Sterling Generators Pvt. Ltd.	C-56/38, INSTITUTIONAL AREA, SECTOR-62, NOIDA -201307, U.P.	Nityanand Engineer-Sales & Marketing (Panel Division) Noida, UP 201307, India Mobile-+91-8510022170	
	LIGHTING DISTRIBUTION BOARDS	3	E1091	MIKA ENGINEERS	BRANCH OFFICE : 'D'-101, DHEERAJ HERITAGE RESIDENCY II, SHASTRI NAGAR, SANTACRUZ (W), MUMBAI 400 054.	Director : Mr. Asgar Karimi E-mail : mika@mtnl.net.inTelfax : 022-26610081/82/83/84Tel : 02527-249066/70 Cell : 099230 74373 ; Email: asgar@mikaengineers.com	
	LIGHTING DISTRIBUTION BOARDS	4	F04	ELEXPRO ELECTRICALS PVT/ LTD.	C 1/27 & 37 GIDC KABILPORE NAVSARI-396424	02637-265140, Mr. Jssk kumar	

SUB-VENDOR LIST

ITEM CODE	ITEM/SERVICE DESCRIPTION	SL NO.	VENDOR CODE	VENDOR NAME	ADDRESS	PHONE	REMARKS
ES38	LIGHTING DISTRIBUTION BOARDS	5	KM1	KMG ATOZ SYSTEMS	"ATOZ HOUSE" C-49, SECTOR-81, GAUTAM BUDDH NAGAR, NOIDA – 201 305 U. P. (INDIA)	Tel : +91-120-4207920 Fax : +91-120-4207921, 4327958 Phone:098 10 802710	
	LIGHTING DISTRIBUTION BOARDS	6	E05	UNILEC ENGINEERS PVT. LTD.	BEHRAMPUR INDUSTRIAL AREA, BEGAMPUR KHATOLA ROAD, GURGAON-122001	0124-4030247,248, 4559700, 9911087173	
	LIGHTING DISTRIBUTION BOARDS	7	AVA01	AVAIODS TECHNOVATORS LTD.	PLOT NO.25 ,SECTOR-3,IMT-MANESAR, GURGEON-122050 (HARYANA)	KRISHNA KALRA- 09958096168	
	LIGHTING DISTRIBUTION BOARDS	8	ACE01	Adroit Control Engineers Pvt.Ltd.	M/S ADROIT CONTROL ENGINEERS PVT.LTD. PLOT-3, KRISHNA INDL. AREA, SECTOR-25 FARIDABAD – 121004	011-47600700, 0129-4251400	
	LIGHTING DISTRIBUTION BOARDS	9	JC01	JACKSON ENGINEERS	A-43, HOSEIRY COMPLEX, OPPOSITE NSEZ, NOIDA-201305	0120-4302600, 2568923,27	
	LIGHTING DISTRIBUTION BOARDS	10	ADL01	Adlec Systems Private Limited	PLOT NO-277, SWARN PARK, UDYOG NAGAR, MUNDKA, MAIN ROHTAK ROAD, UDYOG NAGAR, NEW DELHI, DELHI 110041	011 2834 5061	
	LIGHTING DISTRIBUTION BOARDS	11	POP01	Popular Switchgears Pvt Ltd	712, ARUN CHAMBERS, TARDEO MAIN ROAD, TARDEO, NEAR TARDEO AIRCONDITIONER MARKET, MUMBAI - 400034	-9362634406	
	LIGHTING DISTRIBUTION BOARDS	12	CS01	CANDS	I/202, ANSA INDUSTRIAL ESTATE, SAKI VIHAR ROAD, SAKINAKA, ANDHERI (EAST), MUMBAI-72	022-28570858	
	LIGHTING DISTRIBUTION BOARDS	13	PYRE01	Pyrotech Electronics Pvt. Ltd.	M/s Pyrotech Electronics Pvt. Ltd.(Unit -1) Led Light, Sensor Division F-16A, Road No.3 Mewar Industrial Area, Madri Udaipur -313003, Rajasthan,	Concern Person – Mr. Praveen sisodiya (psisodiya@pyrotechlighting.com) Ankit Kumar Sr. Engineer(North Region -Sales & Marketing) # +91- 7340061769, 8287897309	
	LIGHTING DISTRIBUTION BOARDS	14	PCS01	Positronics Pvt. Ltd.	POSITRONICS HOUSE ,882/ 2, G.I.D.C. MAKARPURA,VADODARA 390010 GUJARAT	+91 265 2642496 Fax: +91 265 264 7033 / 234 0944 E- mail : info@positronicsindia.com Website:www.positronicsindia.com	
	LIGHTING DISTRIBUTION BOARDS	15	ISC01	Industrial Switchgears & Control Pvt Ltd	S-02 AMARDEEP MAHAL, NANDA PATKAR RD, VILE PARLE EAST, MUMBAI - 400057	(91)-22-26182011	
	LIGHTING DISTRIBUTION BOARDS	16	VC01	M/s Vidhyut Control (I) Pvt.Ltd.	D-12 & 13, SECTOR-17, KAVI NAGAR INDL.AREA, GHAZIABAD – 201002 (DELHI NCR) U.P. INDIA		
LIGHTING DISTRIBUTION BOARDS	17	MIL01	MILESTONE SWITCHGEARS PVT. LTD.	MILESTONE SWITCHGEARS PVT. LTD. 97, UDYOG VIHAR, PHASE-1, GURGEON HARYANA - 122016	Phone Nos.: 0124-4994900 (30 Lines) Fax: 0124-4002973 Email: jaideep.ahuja@milestonesindia.com URL: www.milestonesindia.com		
ES39	LIGHTING FIXTURES (NON LED)	2	E1206	BALIGA LIGHTING EQPT PVT LTD	63A, CP RAMASWAMY ROAD, PB NO 6910, CHENNAI-600018	44-24995505,22680990-4	
	LIGHTING FIXTURES (NON LED)	3	F04	ELEXPRO ELECTRICALS PVT/ LTD.	C 1/27 & 37 GIDC KABILPORE NAVSARI-396424	02637-265140, Mr. Jssk kumar	
	LIGHTING FIXTURES (NON LED)	4	B05	BAJAJ ELECTRICALS	BAJAJ ELECTRICALS LTD. ENGINEERING & PROJECTS BU (NORTH) 3rd FLOOR, GULMOHARHOUSE, COMMUNITY CENTRE 161/B-4, GAUTAM NAGAR, YUSUF SARAI NEW DELHI – 110049	CONTACT PERSON : Mr. S. SREEMANY. SR. MANAGER (PROJECTS) CONTACT DETAILS : (+91) 9871025705. MAIL ID : srabans@bajajelectricals.com;	
	LIGHTING FIXTURES (NON LED)	5	C02	CROMPTON GREAVES	3RD FLOOR, EXPRESS BUILDING,9-10, BAHADUR SHAH ZAFAR MARG, NEAR ITO CROSSING,NEW DELHI-110002, INDIA	91 11 23460700 - 999 Sunil.Das@cgglobal.com, Mr. Prashant Wewhare 9930095703	
	LIGHTING FIXTURES (NON LED)	6	E1051	EVERGREEN ENGG. CO.	EVERGREEN ENGG COMPANY WORKS-5, PLOT NO. 9,10,11,12, SURVEY NO. 242, CHINCH PADA, VASAI EAST-401208	(0250) 6458250	
	LIGHTING FIXTURES (NON LED)	7	P01	PHILIPS	9TH FLOOR,DLF 9B, DLF CYBER CITY, DLF PHASE III,GURGAON-122002	01244606001, Sharad (+919871150447)	
	LIGHTING FIXTURES (NON LED)	8	WP01	WIPRO LTD.	WIPRO CONSUMER CARE AND LIGHTING, 5TH FLOOR, GODREJ ETERNIA -C, OLD PUNE-MUMBAI ROAD, SHIVAJINAGAR, PUNE -411005	020-66098700	
	LIGHTING FIXTURES (NON LED)	9	HP01	M/S HPL ELECTRIC & POWER PVT. LTD	M/S HPL ELECTRIC & POWER PVT. LTD. PLOT NO. 76-B,PHASE-IV, SEC-57, HSIIDC, INDL. AREA , KUNDLI, DIST. -SONEPAT (HARYANA) - 131028	mohitsharma@hplindia.com'	
	LIGHTING FIXTURES (NON LED)	10	SR01	SURYA ROSHNI LIMITED	PADMA TOWER, RAJENDRA PLACE, RAJENDRA PLACE NEW DELHI	011-25810093 ; 9810071832 (Akhilesh Agrawal) aagrawal@sroshni.com	
	LIGHTING FIXTURES (NON LED)	11	HI02	HAVELLS INDIA LIMITED	QRG TOWERS , 2D SECTOR-126, NOIDA-201301	GIRISH KUMAR SHRIVASTAVA +91-9810528922	
	LIGHTING FIXTURES (NON LED)	12	HN13	M/s Halonix Technologies Limited	M/s Halonix Technologies Limited B-31 , Phase –II, Noida Distt. Gautam Budh Nagar (U.P.) Pin- 201305	Mr. Mohit Gautam 'Tel: +919568152111 'mohit.gautam@halonix.co.in'; 'rahul.singh@halonix.co.in'	

SUB-VENDOR LIST

ITEM CODE	ITEM/SERVICE DESCRIPTION	SL NO.	VENDOR CODE	VENDOR NAME	ADDRESS	PHONE	REMARKS
ES40	LIGHTING FIXTURES (LED)	1	NE01	Neev Luminaries	B-6/3 Okhla Industrial Area Phase-2 New Delhi 110020	Phone: 011 40604830-31, M:8826995888 Fax: +91 11 4060 4831 info@neevenergy.in, Jitendra Sahu <jsahu@neevenergy.com>	
	LIGHTING FIXTURES (LED)	2	HI01	HAVELLS INDIA LIMITED	QRG TOWERS , 2D SECTOR-126, NOIDA- 201301	GIRISH KUMAR SHRIVASTAVA +91-9810528922, girish.srivastava@havells.com\	
	LIGHTING FIXTURES (LED)	3	B05	BAJAJ ELECTRICALS	BAJAJ ELECTRICALS LTD. ENGINEERING & PROJECTS BU (NORTH) 3rd FLOOR, GULMOHARHOUSE, COMMUNITY CENTRE 161/B-4, GAUTAM NAGAR, YUSUF SARAI NEW DELHI – 110049	CONTACT PERSON : Mr. S. SREEMANY. SR. MANAGER (PROJECTS) CONTACT DETAILS : (+91) 9871025705. MAIL ID : srabans@bajajelectricals.com;	
	LIGHTING FIXTURES (LED)	4	SR01	SURYA ROSHNI LIMITED		011-25810093 ; 9810071832 (Akhilesh Agrawal) aagrawal@sroshni.com	
	LIGHTING FIXTURES (LED)	5	P01	PHILIPS	9TH FLOOR,DLF 9B, DLF CYBER CITY, DLF PHASE- III,GURGAON-122002	01244606001, Sharad (+919871150447), Mr. Guruseelan M 8939693949, Mr Ashish Sethi 9007077089	
	LIGHTING FIXTURES (LED)	6	HP01	M/S HPL ELECTRIC & POWER PVT. LTD	M/S HPL ELECTRIC & POWER PVT. LTD. PLOT NO. 76-B,PHASE-IV, SEC-57, HSIIDC, INDL. AREA , KUNDLI, DIST.- SONEPAT (HARYANA) - 131028	mohitsharma@hplindia.com, Mr. Nitesh Verma 8851036938, Mr Ajay lakra 9560045423	
	LIGHTING FIXTURES (LED)	7	INS1	INSTA POWER	PLOT NO. - 457 PHASE - V, UDYOG VIHAR, GURGAON - 122016	124-4124000, Mr amit Bhardwar: 8800508090	
	LIGHTING FIXTURES (LED)	8	PT13	Pyrotech Electronics Pvt. Ltd.	M/s Pyrotech Electronics Pvt. Ltd.(Unit -1) Led Light, Sensor Division F-16A, Road No.3 Mewar Industrial Area, Madri Udaipur -313003, Rajasthan,	Concern Person – Mr. Praveen sisodiya : 9314310042(phisodiya@pyrotechli ghting.com) Ms Ritika 9509245814	
	LIGHTING FIXTURES (LED)	9	HN13	M/s Halonix Technologies Limited	M/s Halonix Technologies Limited B-31 , Phase –II, Noida Distt. Gautam Budh Nagar (U.P.) Pin- 201305	Mr. Mohit Gautam 'Tel: +919568152111 'mohit.gautam@halonix.co.in'; M: 9891868793'rahul.singh@halonix. co.in'	
	LIGHTING FIXTURES (LED)	10	JA13	M/s JAQUAR & COMPANY PVT. LTD.	M/s JAQUAR & COMPANY PVT. LTD. Plot No.3 , Sector M-11, IMT Manesar. Gurgaon- 122050 Haryana	Mr. Dhruv Kumar 'Tel: +919350043727 dhruv.kumar@jaquar.com ; gaurav.bhalla@jaquar.com : 9582950282	
	LIGHTING FIXTURES (LED)	11	CR13	M/s CROMPTON GREAVES CONSUMER ELECTRICALS LTD.	M/s CROMPTON GREAVES CONSUMER ELECTRICALS LTD.Tower-3, 1st Floor, East Wing Equinox Business Park LBS Marg, Kurla (West), Mumbai-400070	Mr S L Sivakumar 'Sivakumar L' <sivakumar.sl@crompton.co.in> M: 9176609363	
	LIGHTING FIXTURES (LED)	12	WI13	M/s WIPRO ENTERPRISES PRIVATE LTD.	M/s WIPRO ENTERPRISES PRIVATE LTD. L-8, MIDC Waluj, Aurangabad-431136, Maharashtra, India	Ms Dhanya K K 'dhanya.kk8@wipro.com' M 9891815476, Mr Puneet kalia 'puneet.kalia@wipro.com'	
	LIGHTING FIXTURES (LED)	13	NI13	M/s Nessa Illumination Technologies Pvt. Ltd.	M/s Nessa Illumination Technologies Pvt. Ltd.36/A Devraj Industrial Park, Opp. Sameep Fabrics, Pipalaj Pirana Road, Piplaj, Ahmedabad	Mr. Dhaval Shah <dhaval@nessa.in> M 9825650354, Mr. Akshat Khare <akshat@nessa.in> M: 9016111723	
	LIGHTING FIXTURES (LED)	14	FE13	M/s. Forus Electric Pvt. Ltd.	M/s. Forus Electric Pvt. Ltd. B-313, Okhla Industrial Area, Phase-1, New delhi-110020	Mr. Amit Bharadwaj <amit.bharadwaj@foruselectric.c om> M 8800508090, Mr. Uttam Goyal <uttam@foruselectric.com> M: 8527652687	

ITEM CODE	ITEM/SERVICE DESCRIPTION	SL NO.	VENDOR CODE	VENDOR NAME	ADDRESS	PHONE	REMARKS
ES41	LIGHTING FIXTURES (FLAME PROOF)	1	HI01	HAVELLS INDIA LIMITED	ORG TOWERS , 2D SECTOR-126, NOIDA-201301	GIRISH KUMAR SHRIVASTAVA +91-9810528922	
	LIGHTING FIXTURES (FLAME PROOF)	2	B05	BAJAJ ELECTRICALS	BAJAJ ELECTRICALS LTD. ENGINEERING & PROJECTS BU (NORTH) 3rd FLOOR, GULMOHARHOUSE, COMMUNITY CENTRE 161/B-4, GAUTAM NAGAR, YUSUF SARAI NEW DELHI – 110049	CONTACT PERSON : Mr. S. SREEMANY. SR. MANAGER (PROJECTS) CONTACT DETAILS : (+91) 9871025705. MAIL ID : srabans@bajajelectricals.com;	
	LIGHTING FIXTURES (FLAME PROOF)	3	E1206	BALIGA ELECTRICALS	63A,CP RAMASWAMY ROAD, PB NO 6910, CHENNAI-600018	44-24995505,22680990-4	
ES42	LIGHTING LAMP (NON LED)	1	WP01	WIPRO LTD.	WIPRO CONSUMER CARE AND LIGHTING, 5TH FLOOR, GODREJ ETERNIA -C, OLD PUNE-	020-66098700	
	LIGHTING LAMP (NON LED)	2	E1050	ESSEN DEINKI	FLAT NO. 502, SKYLINE HOUSE 85, NEHRU PLACE NEW DELHI	9818338922	
	LIGHTING LAMP (NON LED)	3	B05	BAJAJ ELECTRICALS	BAJAJ ELECTRICALS LTD. ENGINEERING & PROJECTS BU (NORTH) 3rd FLOOR, GULMOHARHOUSE, COMMUNITY CENTRE 161/B-4, GAUTAM NAGAR, YUSUF SARAI NEW DELHI – 110049	CONTACT PERSON : Mr. S. SREEMANY. SR. MANAGER (PROJECTS) CONTACT DETAILS : (+91) 9871025705. MAIL ID : srabans@bajajelectricals.com;	
	LIGHTING LAMP (NON LED)	4	INS1	INSTA POWER	PLOT NO. - 457 PHASE - V, UDYOG VIHAR, GURGAON - 122016	124-4124000	
	LIGHTING LAMP (NON LED)	5	P01	PHILIPS	9TH FLOOR,DLF 9B, DLF CYBER CITY, DLF PHASE- III,GURGAON-122002	01244606001, Sharad (+919871150447)	
	LIGHTING LAMP (NON LED)	6	HI01	HAVELLS INDIA LIMITED	ORG TOWERS , 2D SECTOR-126, NOIDA- 201301	GIRISH KUMAR SHRIVASTAVA +91-9810528922	
	LIGHTING LAMP (NON LED)	7	HP01	HPL	M/S HPL ELECTRIC & POWER PVT. LTD. PLOT NO. 76-B,PHASE-IV, SEC-57, HSIDC, INDL. AREA , KUNDLI, DIST.- SONEPAT (HARYANA) - 131028	mohitsharma@hplindia.com'	
	LIGHTING LAMP (NON LED)	8	SR01	SURYA ROSHNI LIMITED	PADMA TOWER, RAJENDRA PLACE, RAJENDRA PLACE NEW DELHI	011-25810093 ; 9810071832 (Akhlesh Agrawal) aagrawal@sroshni.com	
	LIGHTING LAMP (NON LED)	9	HN13	M/s Halonix Technologies Limited	M/s Halonix Technologies Limited B-31 , Phase -II, Noida Distt. Gautam Budh Nagar (U.P.) Pin- 201305	Mr. Mohit Gautam 'Tel: +919568152111 'mohit.gautam@halonix.co.in'; 'rahul.singh@halonix.co.in'	
ES43	LIGHTING LAMP (LED)	1	NE01	Neev Luminaries	D-115 , OKHLA INDUSTRIAL AREA, PHASE-1 NEW DELHI – 110020	Phone: +91 11 4060 4830 Fax: +91 11 4060 4831 info@neevenenergy.in	
	LIGHTING LAMP (LED)	2	HI01	HAVELLS INDIA LIMITED	ORG TOWERS , 2D SECTOR-126, NOIDA- 201301	GIRISH KUMAR SHRIVASTAVA +91-9810528922	
	LIGHTING LAMP (LED)	3	B05	BAJAJ ELECTRICALS	BAJAJ ELECTRICALS LTD. ENGINEERING & PROJECTS BU (NORTH) 3rd FLOOR, GULMOHARHOUSE, COMMUNITY CENTRE 161/B-4, GAUTAM NAGAR, YUSUF SARAI NEW DELHI – 110049	CONTACT PERSON : Mr. S. SREEMANY. SR. MANAGER (PROJECTS) CONTACT DETAILS : (+91) 9871025705. MAIL ID : srabans@bajajelectricals.com;	
	LIGHTING LAMP (LED)	4	SR01	SURYA ROSHNI LIMITED	PADMA TOWER, RAJENDRA PLACE, RAJENDRA PLACE NEW DELHI	011-25810093 ; 9810071832 (Akhlesh Agrawal) aagrawal@sroshni.com	
	LIGHTING LAMP (LED)	5	P01	PHILIPS	9TH FLOOR,DLF 9B, DLF CYBER CITY, DLF PHASE- III,GURGAON-122002	01244606001, Sharad (+919871150447)	
	LIGHTING LAMP (LED)	6	HP01	M/S HPL ELECTRIC & POWER PVT. LTD	M/S HPL ELECTRIC & POWER PVT. LTD. PLOT NO. 76-B,PHASE-IV, SEC-57, HSIDC, INDL. AREA , KUNDLI, DIST.- SONEPAT (HARYANA) - 131028	mohitsharma@hplindia.com	
	LIGHTING LAMP (LED)	7	INS1	INSTA POWER	PLOT NO. - 457 PHASE - V, UDYOG VIHAR, GURGAON - 122016	124-4124000	
	LIGHTING LAMP (LED)	8	PT13	Pyrotech Electronics Pvt. Ltd.	M/s Pyrotech Electronics Pvt. Ltd(Unit -1) Led Light, Sensor Division F-16A, Road No.3 Mewar Industrial Area, Madri Udaipur -313003, Rajasthan,	Concern Person – Mr. Praveen sisodiya (psisodiya@pyrotechlighting.com) Ankit Kumar Sr. Engineer(North Region -Sales & Marketing) # +91- 7340061769, 8287897309	
	LIGHTING LAMP (LED)	9	HN13	M/s Halonix Technologies Limited	M/s Halonix Technologies Limited B-31 , Phase -II, Noida Distt. Gautam Budh Nagar (U.P.) Pin- 201305	Mr. Mohit Gautam 'Tel: +919568152111 'mohit.gautam@halonix.co.in'; 'rahul.singh@halonix.co.in'	
ES44	LIGHTING POLES	1	E1033	BOMBAY TUBE & POLES CO.	BOMBAY TUBES & POLES CO. 2ND LANE, DARUKHANA, PLOT NO. 100, MAZGAON, MUMBAI - 10	Tel. : +91 22 23729802, email ID: btpc1954@hotmail.com	
	LIGHTING POLES	2	E1118	RIDHDHI POLES	4/5 INDUSTRIAL ESTATE, GORWA, VADODRA- 390016	0265 - 2283768	
	LIGHTING POLES	3	MK01	MIKA ENGINEERS	BRANCH OFFICE : 'D'-101, DHEERAJ HERITAGE RESIDENCY II, SHASTRI NAGAR, SANTACRUZ (W), MUMBAI 400 054. WORKS : AT POST AGHAI, SHED NO. 2, VILLAGE AGHAI JILLA, SHAHPUR, DIST. THANE 421 601 TEL : 02527-249066/70 CELL : 099230 74373	Director : Mr. Asgar Karimi Email: asgar@mikaengineers.com;mika @mntl.net.in Telfax : 022-26610081/82/83/84 Tel : 02527-249066/70 Cell : 099230 74373	

ITEM CODE	ITEM/SERVICE DESCRIPTION	SL NO.	VENDOR CODE	VENDOR NAME	ADDRESS	PHONE	REMARKS
E344	LIGHTING POLES	4	K02	KL INDUSTRIES	B1 1001 LOK GAURAV, LBS MARG, VIKHROLI WEST, MUMBAI - 400083	(91)-9821013736 (91)-22-25774272	
	LIGHTING POLES	5	B05	BAJAJ ELECTRICALS	BAJAJ ELECTRICALS LTD. ENGINEERING & PROJECTS BU (NORTH) 3rd FLOOR, GULMOHARHOUSE, COMMUNITY CENTRE 161/B-4, GAUTAM NAGAR, YUSUF SARAI NEW DELHI - 110049	CONTACT PERSON : Mr. S. SREEMANY. SR. MANAGER (PROJECTS) CONTACT DETAILS : (+91) 9871025705. MAIL ID : srabans@bajajelectricals.com;	
	LIGHTING POLES	6	TL01	TLL	M/S TRANSRAIL LIGHTING LIMITED (TLL), GAMMON INDIA LIMITED 2ND FLOOR, CENTRIC PLAZA, PLOT NO.8 POCKET-4, SECTOR-11 DWARKA , NEW DELHI -110075	hemant.jain@transrailtd.com'	
E545	LIGHTING SWITCH , SOCKET & S/F UNIT	1	F04	ELEXPRO ELECTRICALS PVT/ LTD.	C 1/27 & 37 GIDC KABILPORE NAVSARI-396424	02637-265140, Mr. Jssk kumar	
	LIGHTING SWITCH , SOCKET & S/F UNIT	2	E1012	ANCHOR	STEEL HOUSE, B WING, PLOT NO. 24, MAHAL INDUSTRIAL ESTATE, MAHAKALI CAVES ROAD, NEAR PAPER BOX, ANDHERI (E), MUMBAI, MAHARASHTRA - 400093	022-30418888.	
	LIGHTING SWITCH , SOCKET & S/F UNIT	3	E1076	KAYCEE	KAYCEE INDUSTRIES LTD., C/O-CMS COMPUTERS LTD., 35A, REAR BLDG., KILOKARI, NEW DELHI-110014	Rajiv Sharma-9312004687	
	LIGHTING SWITCH , SOCKET & S/F UNIT	4	L01	L&T	32, SHIVAJI MARG, P.O. BOX- 6223, NEW DELHI-110015	011-41419554/59	
	LIGHTING SWITCH , SOCKET & S/F UNIT	5	S01	SIEMENS	RC-IN I S NR DEL AREA, JIL BUILDING, TOWER-B, PLOT NO. 78, SECTOR 18, GURGAON-122015, INDIA	0124-2842000, 9873424331 amit.bhadauria@siemens.com	
	LIGHTING SWITCH , SOCKET & S/F UNIT	6	E1068	INDO ASIAN	B-24, PHASE - II , NOIDA - 201305, U.P.	120-3042222	
E546	LIGHTING TRANSFORMER	1	E1021	AUTOMATIC ELECTRIC LTD.	ADDRESS : 96 AB LONAVLA INDUSTRIAL ESTATE	Phone : +91 2114323665 Fax : +91 2114273482	
	LIGHTING TRANSFORMER	2	E1066	INDCOIL	PLOT NO. A- 150/ 151, 23RD U ROAD, WAGLE ESTATE, THANE WEST, CST RD, FRIENDS COLONY, HALLOW PUL, KURLA WEST, MUMBAI, MAHARASHTRA 400070	Phone:022 2583 8305	
	LIGHTING TRANSFORMER	3	E1103	POWER PACK ENTERPRISES	POWER PACK ENTERPRISES MR. NEHAL SHAH / MR. SHARAD SHAH (PARTNER) NO. 3, JAYSHREE SADAN, 1ST FLOOR, OLD NAGARDAS ROAD, ANDHERI EAST MUMBAI - 400069, MAHARASHTRA, INDIA	Call Us:08447573761 Mobile: +(91)-9821787821 +(91)-9821035604	
	LIGHTING TRANSFORMER	4	E1155	VIJAY ELECTRICALS LTD.	6-3-648/1&2, OFF RAI BHAVAN ROAD, SOMAJIGUDA, HYDERABAD - 500 082. ANDHRA PRADESH, INDIA.	Vijay Electricals Mr. Bharat Giri / Ajay Giri (CEO) B 79, Gali No. 60, Sanjay Colony, Sector- 23 Faridabad - 121005, Haryana, India Call Us: 09953353612 websales@vijajelectricals.com	
	LIGHTING TRANSFORMER	5	E1057	GILBERT & MAXWELL	WORKS PLOT G-28 , M.I.D.C., AMBAD NASHIK - 422010, MAHARASHTRA, INDIA	Mr. Sanjeev Kulkarni, (Marketing Manager) Cell: 9822586724 sanjeevkulkarni@gilbert-maxwell.in Phone : + 91 - 253 - 238 25 51 Fax : + 91 - 253 - 238 25 52	
	LIGHTING TRANSFORMER	6	K18	KAPPA ELECTRICALS	KAPPA ELECTRICALS, KAPPA CONSOLIDATED PVT. LTD., SOUTHERN ELECTRIKS 14, CART TRACK ROAD, MADUVANKARAI, CHENNAI - 600 042, INDIA.	PHONE: +91 - 44 - 22454709, 22454516, 22450794, 22450795 FAX: +91 - 44 - 22351662, 22451693 E-MAIL: mira@kappaelectricals.com sales@kappaelectricals.com	
	LIGHTING TRANSFORMER	7	AIE01	Ames Impex Electricals Pvt. Ltd	C-1B/1207, PHASE IV, GIDC NARODA, AHMEDABAD, GUJARAT 382330	Phone:079 2282 1648	
LOCAL PUSH BUTTON STATION (NON FLAME PROOF)	LOCAL PUSH BUTTON STATION (NON FLAME PROOF)	8	A35	GE-POWER	KAMAK TOWER, 3RD FLOOR, PLOT NO. 12-A, TVK INDUSTRIAL ESTATE, EKKADUTHANGAL, GUINDY, CHENNAI-600032	044-49681447	
	LOCAL PUSH BUTTON STATION (NON FLAME PROOF)	9	E1019	ASIATIC	A-58 NARAINA IND. AREA, PHASE-I , NEW DELHI 110028	011 - 25796330, 25796617	
	LOCAL PUSH BUTTON STATION (NON FLAME PROOF)	10	CO1	C&S ELECTRIC LTD.	222, OKHLA IND. ESTATE, PH-III, NEW DELHI-110020	011 - 25793021	
	LOCAL PUSH BUTTON STATION (NON FLAME PROOF)	11	E1051	EVERGREEN ENGG. CO.	EVERGREEN ENGG COMPANY WORKS-5, PLOT NO. 9,10,11,12, SURVEY NO. 242, CHINCH PADA, VASAI EAST-401208	(0250) 6458250	
	LOCAL PUSH BUTTON STATION (NON FLAME PROOF)	12	E1143	TECKNIC CONTROLS	703, MADHAVA, BANDRA, KURLA COMPLEX, BANDRA EAST, MUMBAI, MAHARASHTRA 400051	022-42532507/00 022-24451648	
	LOCAL PUSH BUTTON STATION (NON FLAME PROOF)	13	E1053	EX-PROTECTA LIGHTING EQUIPMENT	305-306, GIDC ESTATE, VITHAL UDYOGNAGAR - 388121 DIST. ANAND, GUJARAT 388121 INDIA	02692-237823	
	LOCAL PUSH BUTTON STATION (NON FLAME PROOF)	14	E1206	BALIGA ELECTRICALS	63A, CP RAMASWAMY ROAD, PB NO 6910, CHENNAI-600018	44-24995505,22680990-4	

ITEM CODE	ITEM/SERVICE DESCRIPTION	SL NO.	VENDOR CODE	VENDOR NAME	ADDRESS	PHONE	REMARKS
ES47	LOCAL PUSH BUTTON STATION (NON FLAME PROOF)	15	E1210	ENPRO ENGG.	NO.995P, DIAMOND PLAZA, 2ND FLOOR, 12TH MAIN ROAD, ANNA NAGAR, CHENNAI-40	044 – 42611526 / 42170338 / 26262716 enproengg@enproengineering.com	
	LOCAL PUSH BUTTON STATION (NON FLAME PROOF)	16	E1132	STERLING SWGR CONTROL PVT.LTD.	P.O. BOX NO. 17023, SORAB HOUSE, 2ND FLOOR, 555, S.B. MARG, DADAR, MUMBAI - 400028, MAHARASHTRA, INDIA	91-22-24222297/24222298/24224236	
	LOCAL PUSH BUTTON STATION (NON FLAME PROOF)	17	F04	ELEXPRO ELECTRICALS PVT/ LTD.	C 1/27 & 37 GIDC KABILPORE NAVSARI-396424	02637-265140, Mr. Jssk kumar	
	LOCAL PUSH BUTTON STATION (NON FLAME PROOF)	18	E1153	VAISHNO(HOTLINE SWGR & CONTROL)	G-19, SECTOR - 11, NOIDA - 201301, UTTAR PRADESH, INDIA	8377805157 9818338922	
	LOCAL PUSH BUTTON STATION (NON FLAME PROOF)	19	J01	JASPER ENGINEERS PVT. LTD.	A-23, SECTOR - 8, NOIDA-201301	0120-4033520/533	
	LOCAL PUSH BUTTON STATION (NON FLAME PROOF)	20	KM1	KMG ATOZ SYSTEMS	C-49, SECTOR-81-NOIDA-201305	120-4207920, 08527897328	
	LOCAL PUSH BUTTON STATION (NON FLAME PROOF)	21	E05	UNILEC ENGINEERS PVT. LTD.	BEHRAMPUR INDUSTRIAL AREA, BEGAMPUR KHATOLA ROAD, GURGAON-122001	0124-4030247,248, 4559700, 9911087173	
	LOCAL PUSH BUTTON STATION (NON FLAME PROOF)	22	B04	BCH	20/4, MATHURA ROAD, FARIDABAD, HARYANA-121006	0129-4293000	
	LOCAL PUSH BUTTON STATION (NON FLAME PROOF)	23	E1035	CANDS	I/202, ANSA INDUSTRIAL ESTATE, SAKI VIHAR ROAD, SAKINAKA, ANDHERI (EAST), MUMBAI-72	022-28570858	
	LOCAL PUSH BUTTON STATION (NON FLAME PROOF)	24	S01	SIEMENS	RC-IN I S NR DEL AREA, JIL BUILDING, TOWER-B, PLOT NO. 78, SECTOR 18, GURGAON-122015, INDIA	0124-2842000, 9873424331 amit.bhadauria@siemens.com	
	LOCAL PUSH BUTTON STATION (NON FLAME PROOF)	25	S03	SCHNEIDER ELECTRIC INDIA PVT. LTD.	9TH FLOOR, BLDG. NO. 10, TOWER-C, DLF CYBER CITY, PH-II, GURGAON-122002	0124-3940400	
	LOCAL PUSH BUTTON STATION (NON FLAME PROOF)	26	E1143	TECKNIC CONTROLS	703, MADHAVA, BANDRA, KURLA COMPLEX, BANDRA EAST, MUMBAI, MAHARASHTRA 400051	022-42532507/00 022-24451648	
	LOCAL PUSH BUTTON STATION (NON FLAME PROOF)	27	E1148	UNITED ELECTRIC	97 UDYOG VIHAR PHASE-I, GURGAON 122015, HARYANA	124 4002970 72	
	LOCAL PUSH BUTTON STATION (NON FLAME PROOF)	28	SRC01	M/s Shrenik & Co.	39A/3, PANCHRATNA INDUSTRIAL ESTATE, SARKHEJ-BAVLA ROAD, CHANGODAR, AHMEDABAD – 382 213		
ES48	LOCAL PUSH BUTTON STATION (FLAME PROOF)						
ES49	LIGHTING PANEL (FLAME PROOF)	1	E1206	BALIGA ELECTRICALS	63A, CP RAMASWAMY ROAD, PB NO 6910, CHENNAI-600018	44-24995505,22680990-4	
	LIGHTING PANEL (FLAME PROOF)	2	SS01	SUDHIR SWITCHGEAR	305/6, APEJAY HOUSE, 130, BOMBAY SAMACHAR MARG, MUMBAI - 400 023. INDIA	Telephone Nos. : 40460000 (100 lines) Fax Nos. : ++91-22-22049381 Email : md@sudhirschwitchgears.com ; works@sudhirschwitchgears.com ; scud@vsnl.com	
ES50	LIGHTING PANEL (NON FLAME PROOF)	1	E1091	MIKA ENGINEERS	D'-101, DHEERAJ HERITAGE RESIDENCY II, SHASTRI NAGAR, SANTACRUZ (W), MUMBAI 400 054.	Director : Mr. Asgar Karimi E-mail : mika@mtnl.net.inTelfax : 022-26610081/82/83/84Tel : 02527-249066/70 Cell : 099230	
	LIGHTING PANEL (NON FLAME PROOF)	2	F04	ELEXPRO ELECTRICALS PVT/ LTD.	C 1/27 & 37 GIDC KABILPORE NAVSARI-396424	02637-265140, Mr. Jssk kumar	
	LIGHTING PANEL (NON FLAME PROOF)	3	VC01	Vidhyut Controls (India) Pvt. Ltd.	M/S VIDHYUT CONTROL (I) PVT.LTD. D-12 & 13, SECTOR-17,KAVI NAGAR INDL.AREA,GHAZIABAD – 201002 (DELHI NCR) U.P. INDIA	0120-4186400, 0120-4186423, 8527005590(DK GUPTA)	
	LIGHTING PANEL (NON FLAME PROOF)	4	KM1	KMG ATOZ SYSTEMS	"ATOZ HOUSE" C-49, SECTOR-81, GAUTAM BUDDH NAGAR, NOIDA – 201 305 U. P. (INDIA)	Tel: +91-120-4207920 Fax: +91-120-4207921, 4327958 Phone:098 10 802710	
	LIGHTING PANEL (NON FLAME PROOF)	5	E05	UNILEC ENGINEERS PVT. LTD.	BEHRAMPUR INDUSTRIAL AREA, BEGAMPUR KHATOLA ROAD, GURGAON-122001	0124-4030247,248, 4559700, 9911087173	
	LIGHTING PANEL (NON FLAME PROOF)	6	AVA01	AVAIODS TECHNOVATORS LTD.	PLOT NO.25 ,SECTOR-3,IMT-MANESAR, GURGEON-122050 (HARYANA)	KRISHNA KALRA- 09958096168	
	LIGHTING PANEL (NON FLAME PROOF)	7	ACE01	Adroit Control Engineers Pvt.Ltd.	M/S ADROIT CONTROL ENGINEERS PVT.LTD. PLOT-3, KRISHNA INDL. AREA, SECTOR-25 FARIDABAD – 121004	011-47600700, 0129-4251400	
	LIGHTING PANEL (NON FLAME PROOF)	8	JC01	JACKSON ENGINEERS	A-43, HOSEIRY COMPLEX, OPPOSITE NSEZ, NOIDA-201305	0120-4302600, 2568923,27	
	LIGHTING PANEL (NON FLAME PROOF)	9	MIL01	MILESTONE SWITCHGEARS PVT. LTD.	MILESTONE SWITCHGEARS PVT. LTD. 97, UDYOG VIHAR, PHASE-1, GURGEON HARYANA - 122016	Phone Nos.: 0124-4994900 (30 Lines) Fax: 0124-4002973 Email: jaideep.ahuja@milestonesindia.com URL: www.milestonesindia.com	
	LIGHTING PANEL (NON FLAME PROOF)	10	PCS01	Positronics Pvt. Ltd.	POSITRONICS HOUSE ,882/ 2, G.I.D.C. MAKARPURA,VADODARA 390010 GUJARAT	+91 265 2642496 Fax: +91 265 264 7033 / 234 0944 E- mail : info@positronicsindia.com Website:www.positronicsindia.com	

ITEM CODE	ITEM/SERVICE DESCRIPTION	SL NO.	VENDOR CODE	VENDOR NAME	ADDRESS	PHONE	REMARKS
	LIGHTING PANEL (NON FLAME PROOF)	11	PYRE01	Pyrotech Electronics Pvt. Ltd.	M/s Pyrotech Electronics Pvt. Ltd(Unit -1) Led Light, Sensor Division F-16A, Road No.3 Mewar Industrial Area, Madri Udaipur -313003, Rajasthan,	Concern Person – Mr. Praveen sisodiya (psisodiya@pyrotechlighting.com) Ankit Kumar Sr. Engineer(North Region -Sales & Marketing) # +91- 7340061769, 8287897309	
ES51	MCB	1	E1088	MDS SWITCHGEAR LTD	314-3175SHAH NAHAR ESTATE	011 - 25793021	
	MCB	2	E1068	INDO ASIAN	B-24, PHASE - II , NOIDA - 201305, U.P.	120-3042222	
	MCB	3	S03	SCHNEIDER ELECTRIC INDIA PVT. LTD.	9TH FLOOR, BLDG. NO. 10, TOWER-C, DLF CYBER CITY, PH-II, GURGAON-122002	0124-3940400	
	MCB	4	E1120	S&S POWER SWITCHGEAR LTD.	NEW NO. 67, OLD NO. 19, DR. RANGA ROAD, MYLAPORE, CHENNAI - 600004	044 - 24988056, 044 - 24988057, 044 - 24988058	
ES52	MCC (FIXED TYPE)	1	S02	SPACEAGE SWITCHGEARS LTD.	68 & 13-A INDUSTRIAL DEVELOPMENT COLONY, MEHRAULI ROAD GURGAON, HARYANA-122001	0124-2302711, 4085091	
	MCC (FIXED TYPE)	2	A01	ASSOCIATED SWGR & PROJ.LTD.	C-10, UPSIDC, INDUSTRIAL AREA, SITE-IV, KASNA ROAD, GREATER NOIDA-201306	0120-4294618,19,20 Asplho@gmail.com	
	MCC (FIXED TYPE)	3	B04	BCH	20/4, MATHURA ROAD, FARIDABAD, HARYANA-121006	0129-4293000	
ES53	LV MOTORS (NON FLAME PROOF)	1	A24	ABB	14, MATHURA ROAD, FARIDABAD, HARYANA-121003	0129-2567580, 09871799449	
	LV MOTORS (NON FLAME PROOF)	2	E1027	BHARAT BIJLEE LTD.	BHARAT BIJLEE LIMITED, 1ST FLOOR, 7-B, RAJINDRA PARK, PUSA ROAD, NEW DELHI - 110 060.	Tel.: + 91 (11) 25816931-33, 35 & 36 DT: +91 25724318 Fax: + 91 (11) 25819640 M:+ 91	
	LV MOTORS (NON FLAME PROOF)	3	C02	CROMPTON GREAVES	3RD FLOOR, EXPRESS BUILDING 9-10, BAHADUR SHAH ZAFAR MARG, NEAR ITO CROSSING,NEW DELHI-110002, INDIA	91 11 23460700- 999 Sunil.Das@cgglobal.com	
	LV MOTORS (NON FLAME PROOF)	4	A35	GE-POWER	KAMAK TOWER, 3RD FLOOR, PLOT NO. 12-A, TVK INDUSTRIAL ESTATE, EKKADUTHANGAL, GUINDY, CHENNAI-600032	044-49681447	
	LV MOTORS (NON FLAME PROOF)	5	K01	KIRLOSKAR ELECTRIC CO LTD.	P.O. BOX 5555 , MALLESWARAM WEST ,BANGALORE 560055	Tel: +91-80-23374865 Fax: +91-80-23377706	
	LV MOTORS (NON FLAME PROOF)	6	L04	LAXMI HYDRAULICS PVT. LTD	129/130, INDUSTRIAL ESTATE PATIL NAGAR, HOTGI ROAD SOLAPUR-413003, MAHARASHTRA	0217- 2357001-005	APPROVED UPTO 200KW
	LV MOTORS (NON FLAME PROOF)	7	M01	MARATHON	MARATHON ELECTRIC INDIA PRIVATE LTD.SECTOR - 11, MODEL TOWN, FARIDABAD - 121006	Ph: +91-129-2286421, 2265340, 4006601 to 4006610	
	LV MOTORS (NON FLAME PROOF)	8	A35	NGEF	POCKET NO.10, FLAT NO. 37 & 38, EXPANDABLE DDA FLATS, NASIRPUR DWARKA,	Ph:(011) 2539 7763	
	LV MOTORS (NON FLAME PROOF)	9	E1115	RAJINDRA ELECT INDUSTRIES	14 SHAH IND ESTATE VEERA DESAI RD,ANDHERI(W) MUMBAI-400053	91-22-26730823, 26730789; 91)-(22)-26730154	
	LV MOTORS (NON FLAME PROOF)	10	S01	SIEMENS	RC-IN I S NR DEL AREA, JIL BUILDING, TOWER-B, PLOT NO. 78, SECTOR 18, GURGAON-122015, INDIA	0124-2842000, 9873424331 amit.bhadauria@siemens.com	
ES54	LV MOTORS (FLAME PROOF)	1	E1115	RAJINDRA ELECT INDUSTRIES	14 SHAH IND ESTATE VEERA DESAI RD,ANDHERI(W) MUMBAI-400053	91-22-26730823, 26730789; 91)-(22)-26730154	
ES55	MODULAR SWITCH BOARD	1	E1012	ANCHOR	STEEL HOUSE, B WING, PLOT NO. 24, MAHAL INDUSTRIAL ESTATE, MAHAKALI CAVES ROAD, NEAR PAPER BOX, ANDHERI (E), MUMBAI, MAHARASHTRA. - 400093	022-30418888.	
	MODULAR SWITCH BOARD	2	F04	ELEXPRO ELECTRICALS PVT/LTD.	C 1/27 & 37 GIDC KABILPORE NAVSARI-396424	02637-265140, Mr. Jssk kumar	
	MODULAR SWITCH BOARD	3	H101	HAVELLS INDIA LIMITED	ORG TOWERS , 2D SECTOR-126, NOIDA-201301	GIRISH KUMAR SHRIVASTAVA +91-9810528922	
ES56	OIL TEMP INDICATOR	1	E1101	PERFECT CONTROLS	BLOCK NO. 7, NORTH ROAD,WEST C.I.T. NAGAR,CHENNAI - 600035, INDIA.	Phone: (91-44) 24341043, 24330387, 42867651 Fax: (91-44) 24345075	
	OIL TEMP INDICATOR	2	E1105	PRECIMEASURE	M/S. PRECIMEASURE CONTROLS PVT. LTD. 168/C, INDUSTRIAL SUBURB, PEENYA 3RD PHASE, BANGALORE - 560058. KARNATAKA, INDIA	Phone EPABX: +91-80-42602702. Fax: +91-80-41552205 E-mail: info@precimeasure.com	
ES57	PROTECTION - RELAYS (PNEUMATIC)	1	S01	SIEMENS	RC-IN I S NR DEL AREA, JIL BUILDING, TOWER-B, PLOT NO. 78, SECTOR 18, GURGAON-122015, INDIA	0124-2842000, 9873424331 amit.bhadauria@siemens.com	
	PROTECTION - RELAYS (PNEUMATIC)	2	S03	SCHNEIDER ELECTRIC INDIA PVT. LTD.	9TH FLOOR, BLDG. NO. 10, TOWER-C, DLF CYBER CITY, PH-II, GURGAON-122002	0124-3940400	
	PROTECTION - RELAYS (PNEUMATIC)	3	A35	GE-MULTILINE, GE INDIA INDUSTRIAL PVT. LTD.	NO. 90-B, ELECTRONICS CITY, HOSUR ROAD, BENGALURU - 560016, KARNATAKA	(080) 41314617, 9945478935	
	PROTECTION - RELAYS (PNEUMATIC)	4	SC01	SCHWEITZER ENGG. LAB (SEL)	406, BHIKAJI CAMA BHAVAN, BHIKAJI CAMA PLACE, MOHAMMADPUR, RK PURAM, NEW DELHI, DL 110066	011 4152 7899	
	PROTECTION - RELAYS (PNEUMATIC)	5	C01	C&S ELECTRIC LTD.	222, OKHLA IND. ESTATE, PH-III, NEW DELHI-110020	011-3088 7520-29	
	PROTECTION - RELAYS (PNEUMATIC)	6	G01	ALSTOM LTD	A-7, SEC-65, NOIDA	0120-479 0000	
	PROTECTION - RELAYS (PNEUMATIC)	7	A24	ABB	14, MATHURA ROAD, FARIDABAD, HARYANA-121003	0129-2567580, 09871799449	
	PROTECTION - RELAYS (PNEUMATIC)	8	C01	AVK-SEG & CONTROLS(I) LTD	C-60,NOIDA PHASE-II	6918834-37	
ES58	PROTECTION - RELAYS (NUMERICAL)	1	S01	SIEMENS	RC-IN I S NR DEL AREA, JIL BUILDING, TOWER-B, PLOT NO. 78, SECTOR 18, GURGAON-122015, INDIA	0124-2842000, 9873424331 amit.bhadauria@siemens.com	
	PROTECTION - RELAYS (NUMERICAL)	2	S03	SCHNEIDER ELECTRIC INDIA PVT. LTD.	9TH FLOOR, BLDG. NO. 10, TOWER-C, DLF CYBER CITY, PH-II, GURGAON-122002	0124-3940400	
	PROTECTION - RELAYS (NUMERICAL)	3	A35	GE-MULTILINE, GE INDIA INDUSTRIAL PVT. LTD.	NO. 90-B, ELECTRONICS CITY, HOSUR ROAD, BENGALURU - 560016, KARNATAKA	(080) 41314617, 9945478935	
	PROTECTION - RELAYS (NUMERICAL)	4	SC01	SCHWEITZER ENGG. LAB (SEL)	406, BHIKAJI CAMA BHAVAN, BHIKAJI CAMA PLACE, MOHAMMADPUR, RK PURAM, NEW DELHI, DL	011 4152 7899	

SUB-VENDOR LIST

ITEM CODE	ITEM/SERVICE DESCRIPTION	SL NO.	VENDOR CODE	VENDOR NAME	ADDRESS	PHONE	REMARKS
ES59	RECEPTACLES - DECORATIVE	1	E1012	ANCHOR	STEEL HOUSE, B WING, PLOT NO. 24, MAHAL INDUSTRIAL ESTATE, MAHAKALI CAVES ROAD, NEAR PAPER BOX, ANDHERI (E), MUMBAI, MAHARASHTRA. - 400093	022-30418888.	
	RECEPTACLES - DECORATIVE	2	F04	ELEXPRO ELECTRICALS PVT/ LTD.	C 1/27 & 37 GIDC KABILPORE NAVSARI-396424	02637-265140, Mr. Jssk kumar	
	RECEPTACLES - DECORATIVE	3	B05	BAJAJ ELECTRICALS	BAJAJ ELECTRICALS LTD. ENGINEERING & PROJECTS BU (NORTH) 3rd FLOOR, GULMOHARHOUSE, COMMUNITY CENTRE 161/B-4, GAUTAM NAGAR, YUSUF SARAI NEW DELHI - 110049	CONTACT PERSON : Mr. S. SREEMANY. SR. MANAGER (PROJECTS) CONTACT DETAILS : (+91) 9871025705. MAIL ID : srabans@bajajelectricals.com;	
	RECEPTACLES - DECORATIVE	4	A03	AJIMERA INDUSTRIES & ENGG. WORKS	AJIMERA INDL AND ENGG. WORKS. AJIMERA HOUSE, A-61 / KHAIRANE MIDC. , TTC INDL. AREA, NAVI MUMBAI - 400705.	Tel : 022 27620299 / 97 / 96 'mail@ajimera.net	
ES60	RESISTOR FOR DC STARTERS	1	B04	BCH	20/4, MATHURA ROAD, FARIDABAD, HARYANA-121006	0129-4293000	
	RESISTOR FOR DC STARTERS	2	C01	C&S ELECTRIC LTD.	222, OKHLA IND. ESTATE, PH-III, NEW DELHI-110020	011-3088 7520-29	
	RESISTOR FOR DC STARTERS	3	E1119	RSI	60,IND.DEV.COLONY, MEHRAULI ROAD, GURGAON-122001	91 - 124 - 2333442	
	RESISTOR FOR DC STARTERS	4	S04	SPEED-O-CONTROL	C-16, NAND JYOT INDUSTRIAL ESTATE, SAFED POOL, ANDHERI-KURLA ROAD, SAFED POOL, MAGAN NATHURAM RD, SHIVAJI NAGAR, SAKINAKA, MUMBAI, MAHARASHTRA 400072	022 2851 8514	
	RESISTOR FOR DC STARTERS	5	E1137	SUSHIL ENGG CORP.	D-7, GHATKOPAR INDUSTRIAL ESTATE, OFF LBS MARG, GHATKOPAR (WEST), AMRUT NAGAR RD, AMRUT NAGAR, GHATKOPAR WEST, MUMBAI, MAHARASHTRA 400086	022 2500 7976	
ES61	SWITCH BOX	1	E1012	ANCHOR	STEEL HOUSE, B WING, PLOT NO. 24, MAHAL INDUSTRIAL ESTATE, MAHAKALI CAVES ROAD, NEAR PAPER BOX, ANDHERI (E), MUMBAI, MAHARASHTRA. - 400093	022-30418888.	
	SWITCH BOX	2	F04	ELEXPRO ELECTRICALS PVT/ LTD.	C 1/27 & 37 GIDC KABILPORE NAVSARI-396424	02637-265140, Mr. Jssk kumar	
	SWITCH BOX	3	B05	BAJAJ ELECTRICALS	BAJAJ ELECTRICALS LTD. ENGINEERING & PROJECTS BU (NORTH) 3rd FLOOR, GULMOHARHOUSE, COMMUNITY CENTRE 161/B-4, GAUTAM NAGAR, YUSUF SARAI NEW DELHI - 110049	CONTACT PERSON : Mr. S. SREEMANY. SR. MANAGER (PROJECTS) CONTACT DETAILS : (+91) 9871025705. MAIL ID : srabans@bajajelectricals.com;	
	SWITCH BOX	4	A03	AJIMERA INDUSTRIES & ENGG. WORKS	AJIMERA INDL AND ENGG. WORKS. AJIMERA HOUSE, A-61 / KHAIRANE MIDC. , TTC INDL. AREA, NAVI MUMBAI - 400705.	Tel : 022 27620299 / 97 / 96 'mail@ajimera.net	
	SWITCH BOX	5	SB02	S.B. ELECTRICAL ENGINEERING CORPORATION	03, SARDAR GRIHA BUILDING, LOHAR CHAWAL, MUMBAI-400002	022- 22069831; 022-66637259	
ES62	TERMINAL BLOCKS	1	C01	WAGO-CONTROLS	C 27, GREATER NOIDA, SECTOR 58, C BLOCK, SECTOR 58, NOIDA, UTTAR PRADESH 201307	0120-2580409/10	
	TERMINAL BLOCKS	2	E1038	CONNECT WELL	309A/4, 3RD FLOOR, KALKAJI, OKHLA IND AREA PH-2, GOVINDPURI, NEW DELHI, DL 110019	9811881085 09871419996 011-65908877	
	TERMINAL BLOCKS	3	E1047	ELMEX CONTROLS PVT. LTD.	12,G.I.D.C.ESTATE,MUKARPURA ROAD,YADODARA-390010	9374631074	
	TERMINAL BLOCKS	4	E1050	ESSEN DEINKI	FLAT NO. 502, SKYLINE HOUSE 85, NEHRU PLACE NEW DELHI	011-26217060	
	TERMINAL BLOCKS	5	E1142	TECHNOPLAST	OPP.I.M.INTER COLLEGE, BEGUM SARAI KHURD ROAD, AMROHA - 244221, U.P.	PH:- 05922 264006 CELL NO:- 9012676000, 9319520799, 9319582467	
	TERMINAL BLOCKS	6	PME-01	M/s PHOENIX MECANO LTD.,	388 BHARE, TALUKA MULSHI, POST GHOTAWADE, PIRANGOOT, INDUSTRIAL AREA, PUNE-412115	TEL. - +912066745000 Awasthi(09971119006) Tel: +91 20 6674 5103, Mobile: +91 90499 95985, Fax: +91 20 6674 5126 contact person : Vishwa bandhu E-mail:d.gupta@pmpl-online.com ;admin@pmpl-online.com	
	TERMINAL BLOCKS	7	E1050	ESSEN DEINKI	FLAT NO. 502, SKYLINE HOUSE 85, NEHRU PLACE NEW DELHI	011-26217060	
ES63	TIMERS - PNEUMATIC	1	B04	BCH	20/4, MATHURA ROAD, FARIDABAD, HARYANA-121006	0129-4293000	
	TIMERS - PNEUMATIC	2	G01	ALSTOM LTD	A-7, SEC-65, NOIDA	0120-479 0000	
	TIMERS - PNEUMATIC	3	L01	L&T	32, SHIVAJI MARG, P.O. BOX- 6223, NEW DELHI-110015	011-41419554/59	
	TIMERS - PNEUMATIC	4	E1144	TELEMECHANIQUE/ SCHNEIDER ELECTRIC INDIA PVT. LTD.	9TH FLOOR, BLDG. NO. 10, TOWER-C, DLF CYBER CITY, PH-II, GURGAON-122002	0124-3940400	TAKEN OVER BY SCHNEIDER
	TIMERS - PNEUMATIC	5	S03	SCHNEIDER ELECTRIC INDIA PVT. LTD.	9TH FLOOR, BLDG. NO. 10, TOWER-C, DLF CYBER CITY, PH-II, GURGAON-122002	0124-3940400	
	TIMERS - PNEUMATIC	6	E01	ELECTRONIC AUTOMATION PVT. LTD.	20, KHB INDUSTRIAL AREA YELAHANKA BANGLORE-560064	080 -28567561 / 080 -28567562 / 080 -42802345	

SUB-VENDOR LIST

ITEM CODE	ITEM/SERVICE DESCRIPTION	SL NO.	VENDOR CODE	VENDOR NAME	ADDRESS	PHONE	REMARKS
ES64	TIMERS - ELECTRONIC	1	E1050	ESSEN DEINKI	FLAT NO. 502, SKYLINE HOUSE 85, NEHRU PLACE NEW DELHI	011-26217060	
ES65	TRANSUCERS	1	E1021	AUTOMATIC ELECTRIC LTD.	ADDRESS : 96 AB LONAVLA INDUSTRIAL ESTATE	Phone : +91 2114323665 Fax : +91 2114273482	
	TRANSUCERS	2	E1202	SOUTHERN TRANSUCERS	INTERTECH B-83, FLATTED FACTORY COMPLEX, NEAR MODI MILLS, OKHLA, NEW DELHI-110020	Mr. Gurmohit Singh 011-41020365 / 9891402128	
ES66	WINDING TEMP INDICATOR	1	E1101	PERFECT CONTROLS	OFFICE ADDRESS: 7, NORTH ROAD, WEST C.I.T. NAGAR, CHENNAI - 600035, INDIA.	Phone: (91-44) 24341043, 24330387, 42867651; Fax: (91-44) 24345075	
	WINDING TEMP INDICATOR	2	E1105	PRECIMEASURE	M/S. PRECIMEASURE CONTROLS PVT. LTD. 168/C, INDUSTRIAL SUBURB, PEENYA 3RD PHASE, BANGALORE - 560058. KARNATAKA, INDIA	Phone EPABX: +91-80-42602702. Fax: +91-80-41552205 E-mail: info@precimeasure.com	
ES67	RECEPTACLE (FLAME PROOF)	1	E1206	BALIGA ELECTRICALS	63A, CP RAMASWAMY ROAD, PB NO 6910, CHENNAI-600018	44-24995505, 22680990-4	
	RECEPTACLE (FLAME PROOF)	2	SS01	SUDHIR SWITCHGEAR	305/6, APEEJAY HOUSE, 130, BOMBAY SAMACHAR MARG, MUMBAI - 400 023. INDIA	Telephone Nos. : 40460000 (100 lines) Fax Nos. : ++91-22-22049381 Email : md@sudhirswhitchgears.com ; works@sudhirswhitchgears.com ; scud@vsnl.com	
	RECEPTACLE (FLAME PROOF)	3	FFP01	FCG FLAME PROOF CONTROL GEAR	A1/53, SHAH & NAHAR INDUSTRIAL ESTATE, SITARAM JADHAV ROAD, LOWER PAREL (W), MUMBAI-400 013	Mr. N. G. Patel CMD Office No: +91-22-43443200 Fax No: +91-22-24960313	
ES68	RECEPTACLE (NON FLAME PROOF)	1	A03	AJMERA INDUSTRIES & ENGG. WORKS	AJMERA INDL. AND ENGG. WORKS. AJMERA HOUSE, A-61 / KHAIRANE MIDC. , TTC INDL. AREA, NAVI MUMBAI - 400705.	Tel : 022 27620299 / 97 / 96 mail@ajmerna.net	
	RECEPTACLE (NON FLAME PROOF)	2	C02	CROMPTON GREAVES	3RD FLOOR, EXPRESS BUILDING, 9-10, BAHADUR SHAH ZAFAR MARG, NEAR ITO CROSSING, NEW DELHI-110002, INDIA	91 11 23460700 - 999 Sunil.Das@cgglobal.com	
	RECEPTACLE (NON FLAME PROOF)	3	E1207	CYCLE ELECTRIC DEVICE & SERV.CO.	A-3, NEAR ANTHEM BIOSCIENCE, KSSIDC INDUSTRIAL AREA, BOMMASANDRA, BOMMASANDRA INDUSTRIAL AREA, BANGALORE, KARNATAKA 560099	Mr. H.Jaishanker +919845039081, 080 - 27833102, 080 - 27833103 : +91 80 41460985 cycloelectric@gmail.com	
	RECEPTACLE (NON FLAME PROOF)	4	B04	BCH	20/4, MATHURA ROAD, FARIDABAD - 121006, HARYANA, INDIA	0(129)-4063000, 9015800189(Ramesh Giri) ramesh.giri@bchindia.com	
	RECEPTACLE (NON FLAME PROOF)	5	B02	BEST & CROMPTON	BEST & CROMPTON ENGINEERING LTD 28C, AMBATTUR INDUSTRIAL ESTATE (NORTH) AMBATTUR, CHENNAI - 600 098	Ph : +91 44 4551 4724 , MRKT DGM Mr. Vi Raj:- 9840593411 bestcromptonviraj@gmail.com	
ES69	EMERGENCY LIGHTING UNIT (FIXED & PORTABLE TYPE)-NON FLAME PROOF	1	B05	BAJAJ ELECTRICALS	BAJAJ ELECTRICALS LTD. ENGINEERING & PROJECTS BU (NORTH) 3rd FLOOR, GULMOHARHOUSE, COMMUNITY CENTRE 161/B-4, GAUTAM NAGAR, YUSUF SARAI NEW DELHI - 110049	CONTACT PERSON : Mr. S. SREEMANY. SR. MANAGER (PROJECTS) CONTACT DETAILS : (+91) 9871025705. MAIL ID : srbans@bajajelectricals.com	
	EMERGENCY LIGHTING UNIT (FIXED & PORTABLE TYPE)-NON FLAME PROOF	2	PEP05	PROLITE AUTOGLO LIMITED,	PROLITE AUTOGLO LTD 25 SINGH INDUSTRIAL ESTATE NO. 3, RAM MANDIR ROAD., GOREGAON (W), MUMBAI, MAHARASHTRA 400104, INDIA	022-67868100 sales@prolite.com	
ES70	EMERGENCY LIGHTING UNIT (FIXED & PORTABLE TYPE)-FLAME PROOF	1					
ES71	24V SUPPLY MODULE WITH COMPLETE ACCESSORIES	1	E1103	POWER PACK ENTERPRISES	POWER PACK ENTERPRISES MR. NEHAL SHAH / MR. SHARAD SHAH (PARTNER) NO. 3, JAYSHREE SADAN, 1ST FLOOR, OLD NAGARDAS ROAD, ANDHERI EAST MUMBAI - 400069, MAHARASHTRA, INDIA	Call Us:08447573761 Mobile: +(91)-9821787821 +(91)-9821035604	
	24V SUPPLY MODULE WITH COMPLETE ACCESSORIES	2	E1066	INDCOIL	ADDRESS: PLOT NO. A-150/ 151, 23RD U ROAD, WAGLE ESTATE, THANE WEST, CST RD, FRIENDS COLONY, HALLOW PUL, KURLA WEST, MUMBAI, MAHARASHTRA 400070	Phone:022 2583 8305	
	24V SUPPLY MODULE WITH COMPLETE ACCESSORIES	3	AIE01	Ames Impex Electricals Pvt. Ltd	C-1B/1207, PHASE IV, GIDC NARODA, AHMEDABAD, GUJARAT 382330	Phone:079 2282 1648	
ES72	ENERGY METER (ANALOG)	1	B07	BHEL (EDN)	MYSORE ROAD, BANGALORE-560026	080-26998500	
	ENERGY METER (ANALOG)	2	E1129	SIMCO ENGG. LTD	NO. 126, K ROAD, TIRUCHIRAPPALLI -620001, TAMIL NADU	Mr. Madaswamy Muthu +(91)-(431)-4046223 +(91)-(431)-4046210 +(91)-9786600915	
	ENERGY METER (ANALOG)	3	R01	RISHABH INST.PVT LTD	RISHABH INSTRUMENTS PVT. LTD. F-31, MIDC, SATPUR NASHIK - 422007 MAHARASHTRA INDIA	marketing@rishabh.co.in 91-253 2202202/203 Fax: 91 253 2351064	
	ENERGY METER (ANALOG)	4	E1009	AUTOMATIC ELECTRIC LTD.	96 AB LONAVLA INDUSTRIAL ESTATE NANGARGAON, LONAVLA-410401	Phone : +91 2114323665 Fax : +91 2114273482	
	ENERGY METER (ANALOG)	5	CON1	CONZERVE SYSTEMS PVT. LTD.(SCHNEIDER)	87, 1ST FLOOR INDUSTRIAL DEVELOPMENT COLONY (IDC) MEHRAULI ROAD, UGURGAON 122001 HARYANA, INDIA.	4268899, 9910695701	
	ENERGY METER (DIGITAL)	1	CON1	CONZERVE SYSTEMS PVT. LTD.(SCHNEIDER)	87, 1ST FLOOR INDUSTRIAL DEVELOPMENT COLONY (IDC) MEHRAULI ROAD, UGURGAON 122001 HARYANA, INDIA.	4268899, 9910695701	

ITEM CODE	ITEM/SERVICE DESCRIPTION	SL NO.	VENDOR CODE	VENDOR NAME	ADDRESS	PHONE	REMARKS
ES73	ENERGY METER (DIGITAL)	2	NK09	M/s Newtek Electricals	M-90, M.I.D.C, Waluj, Aurangabad 431136, Maharashtra, India	Tel/Fax: +91 240 2551555 E-mail: mkt.north@newtekelectricals.com, sales@newtekelectricals.com Mr Sanjeev Aggarwal (9958897890)	
ES74	AMMETER	1	E1009	AUTOMATIC ELECTRIC LTD.	96 AB LONAVLA INDUSTRIAL ESTATE NANGARGAON, LONAVLA-410401	Phone : +91 2114233665 Fax : +91 2114273482	
	AMMETER	2	R01	RISHABH INST.PVT LTD	RISHABH INSTRUMENTS PVT. LTD. F-31, MIDC, SATPUR NASHIK - 422007 MAHARASHTRA INDIA	marketing@rishabh.co.in 91-253 2202202/203 Fax: 91 253 2351064	
	AMMETER	3	NK09	M/s Newtek Electricals	M-90, M.I.D.C, Waluj, Aurangabad 431136, Maharashtra, India	Tel/Fax: +91 240 2551555 E-mail: mkt.north@newtekelectricals.com, sales@newtekelectricals.com Mr Sanjeev Aggarwal (9958897890)	
ES75	VOLTMETER	1	E1009	AUTOMATIC ELECTRIC LTD.	96 AB LONAVLA INDUSTRIAL ESTATE NANGARGAON, LONAVLA-410401	Phone : +91 2114233665 Fax : +91 2114273482	
	VOLTMETER	2	R01	RISHABH INST.PVT LTD	RISHABH INSTRUMENTS PVT. LTD. F-31, MIDC, SATPUR NASHIK - 422007 MAHARASHTRA INDIA	marketing@rishabh.co.in 91-253 2202202/203 Fax: 91 253 2351064	
		3	NK09	M/s Newtek Electricals	M-90, M.I.D.C, Waluj, Aurangabad 431136, Maharashtra, India	Tel/Fax: +91 240 2551555 E-mail: mkt.north@newtekelectricals.com, sales@newtekelectricals.com Mr Sanjeev Aggarwal (9958897890)	
ES76	MPCB	1	S03	SCHNEIDER ELECTRIC INDIA PVT. LTD.	9TH FLOOR, BLDG. NO. 10, TOWER-C, DLF CYBER CITY, PH-II, GURGAON-122002	0124-3940400	
	MPCB	2	L01	L&T	32, SHIVAJI MARG, P.O. BOX- 6223, NEW DELHI-110015	011-41419554/59	
	MPCB	3	S01	SIEMENS	RC-IN I S NR DEL AREA, JIL BUILDING, TOWER-B, PLOT NO. 78, SECTOR 18, GURGAON-122015, INDIA	0124-2842000, 9873424331 amit.bhadauria@siemens.com	
	MPCB	4	A35	GE-POWER	KAMAK TOWER, 3RD FLOOR, PLOT NO. 12-A, TVK INDUSTRIAL ESTATE, EKKADUTHANGAL, GUINDY, CHENNAI-600032	044-49681447	
	MPCB	5	S03	SCHNEIDER ELECTRIC INDIA PVT. LTD.	9TH FLOOR, BLDG. NO. 10, TOWER-C, DLF CYBER CITY, PH-II, GURGAON-122002	0124-3940400	
	MPCB	6	C01	C&S ELECTRIC LTD.	222, OKHLA IND. ESTATE, PH-III, NEW DELHI-110020	011-3088 7520-29	
ES77	MAGNETIC OIL GAUGE	1	E1134	SUKRUT UDYOG	9/1/A, ERANDAWANE, OPPOSITE MEHENDALE GARAGE, ERANDAWANE, GULAWANI MAHARAJ RD, SWAROOP SOCIETY, VAKIL NAGAR, ERANDAWANE, PUNE, MAHARASHTRA 411004	020 2544 1726	
ES78	MULTIFUNCTION METER	1	CON1	CONZERVE SYSTEMS PVT. LTD./ SCHNEIDER ELECTRIC INDIA PVT. LTD.	87, 1ST FLOOR INDUSTRIAL DEVELOPMENT COLONY (IDC) MEHRAULI ROAD, GURGAON 122001 HARYANA, INDIA.	4268899, 9910695701	TAKEN OVER BY SCHNEIDER
	MULTIFUNCTION METER	2	NK09	M/s Newtek Electricals	M-90, M.I.D.C, Waluj, Aurangabad 431136, Maharashtra, India	Tel/Fax: +91 240 2551555 E-mail: mkt.north@newtekelectricals.com, sales@newtekelectricals.com Mr Sanjeev Aggarwal (9958897890)	
ES79	RCCB	1	C01	C&S ELECTRIC LTD.	222, OKHLA IND. ESTATE, PH-III, NEW DELHI-110020	011-3088 7520-29	
	RCCB	2	S03	SCHNEIDER ELECTRIC INDIA PVT. LTD.	9TH FLOOR, BLDG. NO. 10, TOWER-C, DLF CYBER CITY, PH-II, GURGAON-122002	0124-3940400	
	RCCB	3	S01	SIEMENS	RC-IN I S NR DEL AREA, JIL BUILDING, TOWER-B, PLOT NO. 78, SECTOR 18, GURGAON-122015, INDIA	0124-2842000, 9873424331 amit.bhadauria@siemens.com	
	RCCB	4	A35	GE-POWER	KAMAK TOWER, 3RD FLOOR, PLOT NO. 12-A, TVK INDUSTRIAL ESTATE, EKKADUTHANGAL, GUINDY, CHENNAI-600032	044-49681447	
	RCCB	5	L01	L&T	32, SHIVAJI MARG, P.O. BOX- 6223, NEW DELHI-110015	011-41419554/59	
	RCCB	6	C02	CROMPTON GREAVES	RAIL TRANSPORTATION SYSTEMS,VANDANA BUILDING, 11, TOLSTOY MARG, TOLSTOY MARG, NEW DELHI, DL 110001	011 3041 6300	
ES80	PVC WIRES				BIS APPROVED MAKE		
ES81	PEDESTAL FAN & CEILING FAN				REPUTED MAKE		
ES82	EXIT SIGN (FLAME PROOF)				REPUTED MAKE		
ES83	EXIT SIGN (NON FLAME PROOF)				REPUTED MAKE		
ES84	LADDER				REPUTED MAKE		
ES85	HUME PIPE				REPUTED MAKE		
ES86	PHOTOELECTRIC SWITCH				REPUTED MAKE		
ES87	DICHORIC SPOT LIGHTING FIXTURE				REPUTED MAKE		
ES88	HAND LAMP UNIT				REPUTED MAKE		
	LIGHTING DESIGNER	1	AT13	AVAIIDS TECHNOVATORS PVT. LTD.	4A/58, SHANKAR ROAD, NEW DELHI-110060	Mr. Rajendra Panda M: 9910481854 (email: rajendra@avaids.com)	

ITEM CODE	ITEM/SERVICE DESCRIPTION	SL NO.	VENDOR CODE	VENDOR NAME	ADDRESS	PHONE	REMARKS
ES89	LIGHTING DESIGNER	2	BE13	BAJAJ ELECTRICALS LTD.	801 (8th floor), Rustomjee Aspire, Bhanu Shankar Yagnik Marg, Off Eastern Express Highway Sion (E), Mumbai 400022	Mr. S. SREEMANY. SR. MANAGER (PROJECTS) CONTACT DETAILS : (+91) 9871025705. (email: srbans@bajajelectricals.com)	
	LIGHTING DESIGNER	3	KS13	KELSATEK SOLUTIONS PVT. LTD.	50/1 4TH FLOOR, CHURCH STREET, BANGALORE-560001	Mr. S S Mudaliar Sr. VP M: 6380471362 (email: mudaliar@kelsatek.com)	
	LIGHTING DESIGNER	4	SE13	M/s SUMANAM ENGINEERING SERVICES CONSULTANT	1, ADITHYA, KOWDIAR, TRIVANDRUM 695003	Mr. Anshad S Phone: 471-2437588, (email: shaw@sumanam.org)	
	LIGHTING DESIGNER	5	SM13	SPAN MANUFACTURING COMPANY LTD	27 First Floor, Bhiku Building, Murari Ghag Marg, Prabhadevi, Mumbai-400025	Ms Surbhi Jindal M: 9811026321 (email: spanmanufacturing@gmail.com, info@dalighthub.com)	Lighting System designer only for FGD, R&M and Hydro projects
	LIGHTING DESIGNER	6	CL13	CITELUM INDIA PVT. LTD	Y-14A, GREEN PARK MAIN, NEW DELHI-110016	Mr. Satyabrata Meher M: 8155001095, (email: smeher@citelum.in)	Lighting System designer only for FGD, R&M and Hydro projects
	LIGHTING DESIGNER	7	SR13	M/s SURYA ROSHNI LTD	Padma Tower 1, Rajendra Place, New Delhi-110008	Mr. Saurabh Gupta 9999433167, (email: saurabh.gupta@surya.in), AKHILESH AGRAWAL (aagrawal@surya.in)	
	LIGHTING DESIGNER	8	HP13	M/s HPL ELECTRIC & POWER PVT. LTD.	WINDSOR BUSINESS PARK, B-1D, SECTOR-10 NOIDA-201301 (UP)	Name : Mr. Mahesh Sharma Designation: Sr. GM (HOD Projects) Email : msharma@hplindia.com Contact : 9818282236 Ashwani Kumar Mob-9971127370 Email: ashwani@hplindia.com	
	LIGHTING DESIGNER	9	ME13	M/s MIKA ENGINEERS.	Survey No.-47,Shed No.-2,Aghai,Shahapur-Wada Road, Village-Aghai, THANE , Pin 421601; MAHARASHTRA	Name : Mr. Deepak Kumar Nayak Email : deepak@mikaengineers.com Contact : 8976737543 Mr. Asgar B Karimi Mob-9820019739 Email: asgar@mikaengineers.com	
	LIGHTING DESIGNER	10	FED13	M/s. Forus Electric Pvt. Ltd.	M/s. Forus Electric Pvt. Ltd. B-313, Okhla Industrial Area, Phase-1, New delhi-110020	Mr. Amit Bharadwaj <amit.bharadwaj@foruselectric.com> M 8800508090, Mr. Uttam Goyal <uttam@foruselectric.com> M: 8527652687	
	ES90	VAF METER (DIGITAL)	1	NK09	M/s Newtek Electricals	M-90, M.I.D.C, Waluj, Aurangabad 431136, Maharashtra, India	Tel/Fax: +91 240 2551555 E-mail: mkt.north@newtekelectricals.com, sales@newtekelectricals.com Mr Sanjeev Aggarwal (9958897890)
ES91	LED BASED HIGH INTENSITY AVIATION WARNING LIGHTS	1	INS1	M/s INSTA POWER LIMITED	Correspondence Address: M/s Insta Power Limited, S-19, Panch Shila Park, New-Delhi-110017 Manufacturing Unit: M/s Insta Power Limited, Khasra No. 103M, Raipur Industrial Area, Raipur, Bhagwanpur, Roorkee, Uttrakhand-247661	Manu Thakur (electrical1@instapower.com) Deepak Gupta (deepak.gupta@instapower.com) Abhijit R Vaish (abhijit.ra@instapower.com) Satyajit R Vaish (satyajit@instapower.com)	

1236340/2023/PS-PEM-MAX



TITLE

2x660MW TALCHER TPP STAGE-III

DOUBLE GIRDER EOT CRANES ABOVE 100T

SPECIFIC TECHNICAL REQUIREMENTS

SPECIFICATION NO. PE-TS-497-501-A501

REV 00

Section

IC

Date DEC'22

SUB-SECTION – IC**DATA SHEET**



**TECHNICAL SPECIFICATION FOR
200/25T TG HALL EOT CRANE
2x660MW TALCHER TPP STAGE-III**

SPECIFICATION NO. PE-TS-497-501-A501

VOLUME II - B

SECTION - I

SECTION - I C

REV 00

DATE DEC 2022

DATA SHEET FOR TG HALL EOT CRANE WITH VVVF DRIVES

* Information's are to be furnished by bidder during detail engineering stage only.

Sr. No.	DESCRIPTION	TECHNICAL PARTICULARS
1.0.0	General	
1.1.0	Name of manufacturer	*
	a. EOT Crane	*
	b. Crane motors	*
	c. Runway conductors	*
1.2.0	Weight of equipments	
	a. Bridge assembly	*
	b. Trolley assembly	*
	c. Total crane weight	*
	d. Total weight of the gantry rail	*
	e. Total weight of DSL	*
	f. Total weight of all the equipments under this specification	*
1.3.0	Design, fabrication and testing of the crane confirm to standard / code number	Mechanical and Electrical as per IS: 3177-2020 & Structure design in accordance to IS 807:2006 / IS 800:1984. Minimum web thickness - 8mm. Minimum diaphragm/stiffner thickness - 8mm.
1.4.0	Number of crane	Two (2) nos.
1.5.0	Crane classification	M5 (Mechanical and Electrical) as per IS: 807-2006 and 13834 (part-5)-1993
1.6.0	Suitable for outdoor or indoor duty	Indoor
1.7.0	Capacity and lift	200/25T
1.7.1	Main hoist	
	a. Rated SWC – tonnes	200T
	b. Test load SWC – tonnes	Rated SWC and over load test : 125% of SWC
1.7.2	Aux. hoists	
	a. Rated SWC – tonnes	25T
	b. Test load SWC – tonnes	Rated SWC and over load test : 125% of SWC
1.8.0	Span	28.1 m
1.9.0	Operation from	Cabin + Pendent Push Button+ Radio remote control
2.00	CRANE PERFORMANCE	
2.1.0	Crane speed with full load	Full speed M/Min Creep speed M/Min



TECHNICAL SPECIFICATION FOR
200/25T TG HALL EOT CRANE
2x660MW TALCHER TPP STAGE-III

SPECIFICATION NO. PE-TS-497-501-A501

VOLUME II - B

SECTION - I

SECTION - I C

REV 00

DATE DEC 2022

	a.	Main hoist	1.6	0.16 (10% of main speed thru' VVVF drives)
	b.	Aux. hoist	7.5	0.75 (10% of main speed thru' VVVF drives)
	c.	Trolley travel (CT)	15.0	1.5 (10% of main speed thru' VVVF drives)
	d.	Longitudinal bridge travel (LT)	30.0	3.0 (10% of main speed thru' VVVF drives)
2.2.0		Acceleration values	LT motion (bridge travel)	CT motion (trolley travel)
			As per IS: 3177	As per IS: 3177
2.3.0		Lift in Metres		
	a.	Main Hoist	As per Crane clearance diagram	
	b.	Aux Hoist	As per Crane clearance diagram	
2.4.0		Hook Approaches		
	a.	Main hook (cabin end)	As per Crane clearance diagram	
	b.	Aux. Hook (cabin-end)	As per Crane clearance diagram	
	c.	Main hook (other end)	As per Crane clearance diagram	
	d.	Aux. Hook (other end)	As per Crane clearance diagram	
2.5.0		Hand Rail Pipes	32 mm NB Medium class of IS: 1161 having top and bottom rail at height of 1050 mm and 600 mm and vertical post spacing not exceeding 1500 mm with provision of kick plate (100 mm high and 6mm thick)	
3.0.0		COMPONENT DETAILS		
3.1.0		Trolley	<p>The trolley frame shall be built up from heavy steel plates, angles and channels adequately braced to resist vertical, lateral and torsional strains, welded to form a rigid one piece frame. Alternatively, it may be of cast steel construction and should be covered by flooring as far as possible. On bottom of trolley frame, on each side a double spring bumper shall be provided to engage stops at each end of the bridge.</p> <p>800 mm (clear) with hand railing of height of 1100 mm along the cross over walkways on trolley.</p>	
	a.	Type	Fabricated	
	b.	Method of fabrication	Fusion welded	
	c.	Material	Mild Steel (Fe410) Gr-B IS: 2062 100% killed, normalized & Ultrasonically tested	
	d.	Centre to centre distance of wheels (on the same rails)	*	



TECHNICAL SPECIFICATION FOR
200/25T TG HALL EOT CRANE
2x660MW TALCHER TPP STAGE-III

SPECIFICATION NO. PE-TS-497-501-A501

VOLUME II - B

SECTION - I

SECTION - I C

REV 00

DATE DEC 2022

	e.	Whether jacking pads for lifting trolley provided or not	Yes			
3.2.0		Rope drums	Main hoist		Aux. Hoist	
	a.	Dimensions in mm length and diameter (PCD)	*		*	
	b.	Material (Indicate IS)	Seamless pipe ASTM -106 Gr. B or fabricated rolled section to IS: 2062 Gr. B & stress relieved			
	c.	Flange / flangeless	Flanged			
	d.	Numbers provided	One for each hoist			
	e.	Number of grooves	*		*	
	f.	Type of grooves	Identical Right hand and Left hand			
	g.	Diameter on bottom of grooves	*		*	
3.3.0		Rope details				
	a.	Construction	Extra flexible plough steel , 6 x 36 or 6x37 construction			
	b.	Grade	*			
	c.	Standard conforming to	IS: 2266 (latest edition)			
	d.	Diameter in mm	*		*	
	e.	Breaking strength	*		*	
	f.	Tensile designation	*		*	
	g.	Factor of safety	5.25 as per IS		5.25 as per IS	
	h.	Type of core	Steel		Steel	
	i.	Number of falls	*		*	
	j.	Length of rope	*		*	
3.4.0		Sheaves details	Main hoist		Aux. Hoist	
	a.	Material	Fe 410 WA IS: 2062 Gr. B / CS Gr. 280-520 IS: 1030 Design as per IS: 3177- 1999			
	b.	Diameter of main sheaves in mm on Root	*		*	
	c.	Diameter of Equalizing sheaves (in mm) on Root	Should not be less 62% of calculated main sheave diameter		Should not be less 62% of calculated main sheave diameter	
	d.	Type of guards provided	Fabricated from rolled steel plate			
3.5.0		COUPLINGS & SHAFTING				
3.5.1		Coupling details (between motor and gear box)	Main hoist	Aux. Hoist	Cross Travel	Long Travel
	a.	Type	Flexible shock absorbing coupling excepting pin bush type			
	b.	Size & Torque rating	*			
	c.	Guards and enclosures	Provided			



TECHNICAL SPECIFICATION FOR
200/25T TG HALL EOT CRANE
2x660MW TALCHER TPP STAGE-III

SPECIFICATION NO. PE-TS-497-501-A501

VOLUME II - B

SECTION - I

SECTION - I C

REV 00

DATE DEC 2022

	d.	Coupling material and hardness	All couplings shall be of cast, wrought or from forged steel, tooth portion to be heat treated to hardness HB241-280			
3.5.2		Coupling details (between gear box and wheels)	Cross Travel (CT)		Long Travel (LT)	
	a.	Type	Flexible geared type			
	b.	Size & Torque rating	*			
	c.	Guards and enclosures provided	Yes			
3.5.3		Coupling details (between gear box and rope drum)	Main hoist		Aux. Hoist	
	a.	Type	One of the following arrangements will be adopted for connecting the rope drum with the gear- box. 1. Flexible joint, incorporating flexible geared coupling housed within the drum. 2. Fully flexible geared coupling between the drum & gearbox.			
	b.	Size	*			
	c.	Guards and enclosures provided	Yes			
3.5.4		Shafting (Output)	Cross Travel		Long Travel	
	a.	Diameter in mm	*		*	
	b.	Factor of Safety	As per IS: 3177-2020			
	c.	Number of support bearings	*		*	
	d.	Type of support bearing	*		*	
	e.	Arrangement of lubrication	Grease cups / Nipple			
	f.	Type of lubricant	Grease			
	g.	Max unsupported length of shaft in mm	*		*	
3.6.0		Gear box details				
3.6.1		Hoist Motions	MH	MH Micro	AH	AH micro
	a.	Type of mounting of gear box	Horizontal / Vertical			
	b.	Classification	Suitable for M5 duty			
	c.	Total number of reductions	*	Thru' VVVF drive	*	Thru' VVVF drive
	d.	Type of gears	Helical / Spur		Helical / Spur	
	e.	Reduction ratio	*			
	f.	Type of lubrication (grease / splash / pump lubrication)	Splash Lubrication			
	g.	Hardness (BHN) – gear	217 to 255 BHN			

1236340/2023/PS-PEM-MAX

PEM-6666-



TECHNICAL SPECIFICATION FOR
200/25T TG HALL EOT CRANE
2x660MW TALCHER TPP STAGE-III

SPECIFICATION NO. PE-TS-497-501-A501

VOLUME II - B

SECTION - I

SECTION - I C

REV 00

DATE DEC 2022

	h.	Hardness (BHN) – pinion	266 to 300BHN			
	i.	Difference in Gear and pinion hardness	Min 20 BHN			
	j.	Materials (gear/pinions)	Main Gears En 9/ 55C8/ IS2707 Gr. 1or 2. Pinions En 19/EN 24. Hardness conforming to IS: 3177 (latest edition) Gears to be hardened, tempered & heat treated as per IS 4460			
	k.	Casings	Fabricated Fe 410w IS: 2062 Gr B & stress relieved			
	l.	Noise level	85 db	NA	85 db	NA
	m.	Standard conforming to	IS: 4460 / AGMA			
3.6.2		Travel Motions	CT	CT micro	LT	LT micro
	a.	Type of mounting gear box	Vertical/ Horizontal	NA	Vertical/ Horizontal	NA
	b.	Classification	M5 duty			
	c.	Total number of reduction	*	Thru' VVVF drive	*	Thru' VVVF drive
	d.	Type of gears	Helical / Spur		Helical / Spur	
	e.	Reduction ratio	*		*	
	f.	Type of lubrication (grease / splash / pump lubrication)	Splash Lubrication			
	g.	Hardness (BHN) – gear	217 to 255 BHN			
	h.	Hardness (BHN) – pinion	266 to 300BHN			
	i.	Difference in Gear and pinion hardness	Min 20 BHN			
	j.	Materials (gear / pinions)	Main Gears En 9/ 55C8/ IS2707 Gr. 1or 2. Pinions En 19/EN 24. Hardness conforming to IS: 3177 (latest edition) Gears to be hardened, tempered & heat treated as per IS 4460			
	k.	Casings	Fabricated Fe 410w IS: 2062 Gr A/B & stress relieved			
	l.	Standard conforming to	IS: 4460 / AGMA			
3.7.0		Wheels details	Cross travel	Long travel		
	a.	Material	Grade C55Mn75 of IS 1570 (Part 1 and Part 2/Sec 2) or 42CrMo4 or equivalent as per IS 3177-2020. UTS required for selection of P _L value as indicated in Table 6 of IS 3177 shall be witnessed by BHEL.			
	b.	Hardness	300 – 350 BHN			
	c.	Depth of hardness	10 mm (min)			
	d.	Tread diameter in mm	*	*		
	e.	Tread width in mm	*	*		
	f.	Process of hardening	Volume hardening			
	g.	Type	Double flanged			
	h.	Numbers provided	4 nos.	8 nos.		
	i.	Specification conforming to	IS: 3177			



TECHNICAL SPECIFICATION FOR
200/25T TG HALL EOT CRANE
2x660MW TALCHER TPP STAGE-III

SPECIFICATION NO. PE-TS-497-501-A501

VOLUME II - B

SECTION - I

SECTION - I C

REV 00

DATE DEC 2022

		Arrangement of lubrication	Grease			
3.8.0		<u>Lifting hooks</u>	MH		AH	
	a.	Type	Ramshorn shank with safety latch swiveling type as per latest edition of IS-5749		Plain with safety latch swiveling type as per latest edition of IS: 15560	
	b.	Safe lifting capacity	200 T as per IS-5749		25 T as per IS: 15560	
	c.	Material	✓ As per IS-5749 ✓ Class 3 for hook of grades L & M respectively as per IS 1875:1992 for hooks conforming to IS : 15560			
	d.	Standard conforming to	IS-5749		IS: 15560	
	e.	Hook can rotate	Yes			
	f.	Safety latch on hook provided	Yes			
	g.	Locking device on swivelling hook required or not	Provided			
3.9.0		Buffers	Cross travel		Long travel	
	a.	Type	Spring loaded type. To be designed to bring the loaded crane (In calculation crane is considered to be loaded with SWL) to rest from speed of 50% of the rated speed.			
	b.	Numbers provided	4		4	
	c.	Details of end stop	Mild steel, grade 'B' of IS 2062 in 100% killed, normalised and ultrasonically tested quality or high strength steel of IS 8500 as appropriate.			
3.10.0		Brakes				
3.10.1		Hoist Motions	MH	MH micro	AH	AH micro
	a	Type of brake	AC Electro-Hydraulic Thruster operated			
	b.	Diameter of brake in mm	*	NA	*	NA
	c.	Torque rating Kg. M	*		*	
	d.	Number provided per motor	2		2	
	e.	Braking capacity (% of torque transmitted to the brake drum with full load.)	150%		150%	
	f.	Braking torque actually required	*		*	
	g.	Material				
		• Brake liners	Ferrodo liners			
		• Drum	CS IS : 1030 / CL 4 IS : 1875			
		• Springs	As per manufacturers standard			
	h.	Braking distance in mm	*	NA	*	NA
3.10.2		Travel Motions	CT	CT micro	LT	LT micro



TECHNICAL SPECIFICATION FOR
200/25T TG HALL EOT CRANE
2x660MW TALCHER TPP STAGE-III

SPECIFICATION NO. PE-TS-497-501-A501

VOLUME II - B

SECTION - I

SECTION - I C

REV 00

DATE DEC 2022

	a.	Type of brake (ac / dc / thruster)	AC Electro-Hydraulic Thruster operated		AC Electro-Hydraulic Thruster operated		
	b.	Dia of brake in mm	*	NA	*	NA	
	c.	Torque rating KgM	*		*		
	d.	Number provided per motor	2		2		
	e.	Braking capacity (% of motor rated torque before derating)	125%		125%		
	f.	Braking torque actually required	*		*		
	g.	Material					
		• Brake liners	Ferodo liners				
		• Drum	CS IS : 1030 / CL4 IS : 1875				
		• Springs	As per manufacturers standard				
		• Thrusters	*				
	h.	Braking distance in mm	*	NA	*	NA	
		Storm brake	2 No's LT parking brake (storm brake) shall be provided				
3.11.0		Drive system for hoisting					
	a.	Arrangement of drive from motor to rope drum (main)	Through geared coupling and gear box				
	b.	Arrangement of drive from pony motor to rope drum (creep speed)	Pony motor NA as creep speed through VVVF drive				
3.12.0		Bearings	Crane hook	Trolley wheels	Rope drum	Gear box	Any other assembly
	a.	Type	Antifriction ball / roller bearings				
	b.	Number provided for each	As per assembly requirements				
	c.	Method of lubrication	Centralised grease lubrication with hand operated grease pump for all bearings as per bidder's standard proven practice.				
	d.	Bearing life	10,000 working hours.				
3.13.0		Bridge girder					
	a.	Type & Quantity	Box type – 2 nos. Material: Mild steel, grade 'B' of IS 2062 in 100% killed, normalised and ultrasonically tested quality or high strength steel of IS 8500 as appropriate.				
	b.	Size	*				



TECHNICAL SPECIFICATION FOR
200/25T TG HALL EOT CRANE
2x660MW TALCHER TPP STAGE-III

SPECIFICATION NO. PE-TS-497-501-A501

VOLUME II - B

SECTION - I

SECTION - I C

REV 00

DATE DEC 2022

		Limiting value of stress	The following shall be taken into consideration. The static loads due to the dead weight, the loads due to working load multiplied by dynamic coefficient and the two most unfavorable horizontal effects, excluding buffer forces. All these loads must then be multiplied by the amplifying coefficient.
	c.	Vertical Deflection	Span / 900
	d.	Type of connection to end carriage	By fitted bolts
	e.	Width	*
	f.	Length	*
3.14.0		Rails	
	a.	Type / section	Rails sections as per IS: 3443 Grade 50 C 12. Joint to be butt-welded by thermit welding or fusion welding/ CR-100 with 45 degrees angle.
	b.	Standard conforming to	IS: 3443
	c.	Weight per metre	*
	d.	Material	50C12 / 55C11
	e.	Top width in mm	*
	f.	Height in mm	*
3.15.0		Type of platform required on the bridge	Chequered plate platform 6mm thick over plain as per IS : 3502
	a.	Length	Full span length
	b.	Walkways	Access walkways of not less than 800 mm (clear) with hand railing of height of 1100 mm along the both side of bridge girder and cross over walkways.
	c.	Type of access from gantry girder level to crane bridge	Rung ladder at ends from gantry girder level walkway to crane bridges walkway
	d.	Type of access to maintenance cage from crane bridges walkway	Rung ladder
	e.	Type of access to Cabin from crane bridges walkway	By Staircase
	f.	Provided at both ends	Yes
3.16.0		Operators cabin	
	a.	Type of construction	Open type with minimum 6mm toughened glass.
	b.	Area and minimum clear height	2500x1850 mm with a head room of 2000 mm
	c.	Operator's seat	Revolving type



TECHNICAL SPECIFICATION FOR
200/25T TG HALL EOT CRANE
2x660MW TALCHER TPP STAGE-III

SPECIFICATION NO. PE-TS-497-501-A501

VOLUME II - B

SECTION - I

SECTION - I C

REV 00

DATE DEC 2022

	d.	Warning gong	A foot operated electric warning horn of double bell type suitable for 240 V AC. of noise level 95 dB at 3.5 m. One brass gong suspended outside the Cabin and operated from inside.			
			A distinct type alarm with conspicuous warning lights on either side of the crane bridge to indicate overloading of crane.			
	e.	Position of controllers	In front/ side of operator's chair			
	f.	Ventilation	One no non oscillating ventilating electric fan in cabin			
	g.	Siren	One (1) heavy duty type industrial siren shall be provided with Each crane. The siren shall be operated from foot-switch in the Operator's cabin.			
3.17.0		End carriage span (wheel base)	As per IS 807 (latest edition)			
3.18.0		Motors				
3.18.1		Hoist Motions	MH	MH micro	AH	AH micro
	a.	Type	Three phase Squirrel Cage Induction motors to be operated from VFD system shall be suitable for speed range and torque without exceeding temperature rise limits as specified elsewhere in this specification. These motors shall be provided with VPI insulation and insulated bearing on one side and shall be suitable for Inverter duty.	Thru VVVF drive	Three phase Squirrel Cage Induction motors to be operated from VFD system shall Be suitable for speed range and torque without exceeding temperature rise limits as specified elsewhere in this specification. These motors shall be provided with VPI insulation and insulated bearing on one side and shall be suitable for Inverter duty.	Thru VVVF drive
	b.	Enclosure	TEFC	NA	TEFC	NA
	c.	Numbers furnished	One per motion			
	d.	Voltage, phase and frequency	415V \pm 10%, 3 Ph., 4 wire, 50 Hz, +3/-5 % Combined voltage & frequency variation = 10% absolute			
	e.	Class of protection	IP – 55			
	f.	Rated capacity (KW)	The motor shall be suitable for 40% CDF. Motor nameplate rating at 50 C shall have Motor rating will be calculated keeping margin of at least 10% over the maximum power requirement in the duty condition specified.			
	g.	Duration factor/duty	40 % CDF / S-4			
	h.	Speed (rpm)	*			



TECHNICAL SPECIFICATION FOR
200/25T TG HALL EOT CRANE
2x660MW TALCHER TPP STAGE-III

SPECIFICATION NO. PE-TS-497-501-A501

VOLUME II - B

SECTION - I

SECTION - I C

REV 00

DATE DEC 2022

	i.	Class of insulation	Class 'F' for sq. cage motors with temp rise limited to 70 C			
	j.	Number of starts/ hour	Starts / hr as per IS 3177-2020			
	k.	Contactors for motor	*			
	l.	Overload protection for motors provided	Yes			
	m.	Space heater requirements	For motors of rating 30 KW and above			
3.18.2		Travel Motions	CT	CT micro	LT	LT micro
	a.	Type	Three phase Squirrel Cage Induction motors to be operated from VFD system shall be suitable for speed range and torque without exceeding temperature rise limits as specified elsewhere in this specification. These motors shall be provided with VPI insulation and insulated bearing on one side and shall be suitable for Inverter duty	Thru VVVF drive	Three phase Squirrel Cage Induction motors to be operated from VFD system shall be suitable for speed range and torque without exceeding temperature rise limits as specified elsewhere in this specification. These motors shall be provided with VPI insulation and insulated bearing on one side and shall be suitable for Inverter duty	Thru VVVF drives
	b.	Enclosure	TEFC	NA	TEFC	NA
	c.	Numbers furnished	1	NA	2	NA
	d.	Voltage, phase and frequency	415V \pm 10%, 3 Ph., 4 wire, 50 Hz, +3/-5 % Combined voltage & frequency variation = 10% absolute			
	e.	Class of protection	IP – 55			
	f.	Rated capacity (KW)	The motor shall be suitable for 40% CDF. Motor nameplate rating at 50 C shall have Motor rating will be calculated keeping margin of at least 10% over the maximum power requirement in the duty condition specified.			
	g.	Duration factor/duty	40 % CDF / S-4			
	h.	Speed (rpm)	*			
	i.	Class of insulation	Class 'F' for sq. cage motors with temp rise limited to 70C			
	j.	Number of starts/ hour	Starts / hr as per IS 3177-2020.			
	k.	Contactors for motor	*			
	l.	Overload protection for motors provided	Yes			



TECHNICAL SPECIFICATION FOR
200/25T TG HALL EOT CRANE
2x660MW TALCHER TPP STAGE-III

SPECIFICATION NO. PE-TS-497-501-A501

VOLUME II - B

SECTION - I

SECTION - I C

REV 00

DATE DEC 2022

	m.	Space heater requirement	For motors of rating 30 KW and above			
3.18.3		Motor Duty and pull out torque	Duty S4 and pull out torque 275% of full load torque			
3.19.0		Limit switches	Main hoist	Aux. hoist	Cross Travel	Long Travel
	a.	Type	Rotary gear + Gravity		Lever type (one way/ two way)	
	b.	Number provided	1+1	1+1	2/1	2
	c.	Rating of contacts	*			
	d.	Material of contacts	Double break Silver Cadmium			
	e.	Control voltage / Enclosure	110 V/ IP 55			
3.20.0		Power conductors (DSL)				
	a.	Type	LT: PVC shrouded Cu/Al conductor bus bar. CT: EPR insulated, copper conductor trailing cables, as per IS: 9968, on the bridge.			
	b.	Size	Shall be sized with a margin of 10% over load requirement. Voltage drop at motor terminal shall be limited to 2% at extreme positions. Protective cover over DSL to be provided.			
	c.	Material	*			
	d.	Numbers	*			
	e.	Length	Suitable for bay length			
	f.	Guard provided	Yes			
3.21.0		Protective Panel				
	a.	Make	OEM			
	b.	Size	*			
	c.	Material	Sheet steel 2 mm size			
	d.	Numbers and location	One number located in cabin			
	e.	DOP	IP 54			
3.22.0		Control panel				
	a.	Make	OEM			
	b.	Size	*			
	c.	Material	Cold Rolled sheet steel 2mm size			
	d.	Numbers and location	One each for MH, AH, CT and LT located on bridge platform with space heaters.			
	e.	Degree of protection	IP 54			
3.23.0		Master Controllers (Desk Type)	Main Hoist	Aux Hoist	Cross Travel	Long Travel
	a.	Number of steps	5	5	4	4
	b.	Voltage & current rating	415 V/10 A			



TECHNICAL SPECIFICATION FOR
200/25T TG HALL EOT CRANE
2x660MW TALCHER TPP STAGE-III

SPECIFICATION NO. PE-TS-497-501-A501

VOLUME II - B

SECTION - I

SECTION - I C

REV 00

DATE DEC 2022

	c.	Type	Heavy duty type having DOP IP54. Release of operators' hand from the controls shall stop motion and set brakes automatically.
	d.	Location	In cabin
3.24.0		Control for Hoists /CT/LT operations	Through Variable Voltage Variable frequency drive
	a.	Speed control	Thru' VVVF with minimum 6 pulse design
	b.	Starting torque of VVVF	Up to 400 % typical with encoder
	c.	Starting current	Less than 150 % of rated torque.
	d.	Temperature	VVVF system shall be capable of withstanding up to 50 ° C without derating.
3.25.0		Cable	Power
	a.	Material	Mentioned in Electrical Portion
	b.	Type	
	c.	Size	
	d.	Voltage grade	
	e.	Voltage drop	Cable from main isolating switch (1.5M above operating floor) to motor terminal shall be so sized that the voltage drop does not exceed 2% of rated voltage at motor terminals.
3.26.0		Earthing	
	a.	Material of earthing	G.I / Copper
	b.	Earthing as per specification	Yes
3.27.0	a.	Contactors	AC 4 duty for reversing application. AC 3 duty for non-reversing application
	b.	Switches	AC 23 for motor application, AC 22 for other application.
	c.	Fuses	HRC
	d.	Overload relay	Temperature compensated bimetallic with single phasing preventor.
3.28.0		Power supply	Owner shall provide Two (2) nos. 415 V, 3 phase, 4 wire supply at operating floor near A row column at centre of bay length shall be provided. Bidder shall provide change over switch in enclosure to receive above power supply.
3.29.0		Transformer	(Dry type, With Insulation Class B or Better)
	a.	Quantity	2 X 100 % for control, 1 no for lighting & 1 no for hand lamp.
	b.	Voltage Rating	Control 415/110V, Lighting 415/240V and hand lamp 415/24V.
	c.	KVA rating	20% over loading to be considered while sizing the rating
3.30.0		Illumination	
	a.	In cabin	40W florescent tube + Bulk head fitting with 60W incandescent lamp – 1 each 2 nos. 24V- 5A-3 pin industrial socket.
	b.	Over Bridge	4 no. 60W Bulk head fittings with Florescent lamp lamps and 4 nos.24V 20A -3 pin Industrial socket
	c.	Under bridge	4 nos. 250 W HPSV lamps
	d.	For inspection of crane components	One (1) portable 40W hand lamp with min. half span length flexible cable for inspection of crane components
3.31.0		Fire Extinguisher	



TECHNICAL SPECIFICATION FOR
200/25T TG HALL EOT CRANE
2x660MW TALCHER TPP STAGE-III

SPECIFICATION NO. PE-TS-497-501-A501

VOLUME II - B

SECTION - I

SECTION - I C

REV 00

DATE DEC 2022

	a.	Type and size	4.5 kg CO ₂ type
	b.	Location	One in cabin and Three on bridge
3.32.0		Maintenance cage	Suitable inspection cages to accommodate two persons to facilitate inspection of down shop lead.
3.33.0		Type of control for Hoists/ CT/LT operation	Through VVVF drive
3.34.0		VVVF Drive	Mentioned Elsewhere in the specification
3.35.0		Mechanical overload protection (Load Cell)	To be provided for hoist mode
3.36.0		Painting	As per Annexure- IV
3.37.0		Isolating switch	Two nos. isolating switch shall be provided at extreme ends of the bay length, at a distance of approximately 20 mtrs. From the centre line of first & last column for maintenance of the cranes.
3.38.0		Whether tandem operation envisaged	Yes
3.39.0		Lifting Beam & its capacity	A suitable indicating device to indicate the difference in the lifts of the two cranes, which shall be limited to 500 mm shall be provided on the lifting beam. The level difference indication shall be visible from ground level. A limit switch shall be provided to give alarm at both the cabins to enable the crane operators to control the level difference within 500mm.

S. No.	Description	Weight (Tons)	Remarks I Reference
a	SWL of Lifting Beam	326	
b	Design Capacity of Lifting Beam (considering 5% margin on SWL)	326 X 1.05= 342.3	Design capacity of lifting beam shall be used for structural sizing
c	Overload testing of Lifting Beam at manufacturer's works	1.25 X SWL	

Note: Other requirements for the system.

- Centralized grease lubrication with hand operated grease pump for all bearings.
- Upper pulley block to be placed above crab platform level for ease in approach during maintenance.
- The crane electrical shall be designed for ambient air temperature of 50 Deg. C relative humidity of 100%. The equipment shall operate in highly polluted environment.
- All electrical equipment, accessories and wiring shall have tropical protection involving special treatment of insulation and metal against fungus, insects and corrosion.
- Emergency Switch-Mushroom type emergency STOP push buttons to open the main contactor shall be furnished at least one in operator's cabin and two on bridge platform within easy reach.
- DSL phase indicating lamps to be provided.
- Additional features in operator's cabin and on pendant push button:

Emergency Push Button

Switches for lights and bells

Lamps for Power 'ON' indication and emergency corner switch operation



TECHNICAL SPECIFICATION FOR
200/25T TG HALL EOT CRANE
2x660MW TALCHER TPP STAGE-III

SPECIFICATION NO. PE-TS-497-501-A501

VOLUME II - B

SECTION - I

SECTION - I C

REV 00

DATE DEC 2022

- Two nos. fail safe LT storm/parking brakes, truck end mounted, hydraulic rail clamp type of adequate capacity (depending on wind pressure) to be provided. The setting shall include automatic engagement of clamps in case of crane is left idle for five minutes (adjustable).
- The following parameters shall be considered for design and selection of LT storm /parking brakes.
 - a) The basic wind speed "Vb" at ten metres above the mean ground level: 50 meters /second
 - b) The risk coefficient "K1" 1.08
 - c) Category of terrain Category-2
 - d) Other factors in line with IS 875.

1236340/2023/PS-PEM-MAX



TITLE

2x660MW TALCHER TPP STAGE-III

DOUBLE GIRDER EOT CRANES ABOVE 100T

STANDARD TECHNICAL REQUIREMENTS

SPECIFICATION NO. PE-TS-497-501-A501

REV 00

Section

IIA

Date DEC'22

SECTION – II

STANDARD TECHNICAL SPECIFICATION

SUB-SECTION IIA – Standard Technical Requirement (Mechanical)

	TITLE	SPECIFICATION NO.	PE-TS-497-501-A501
	2x660MW TALCHER TPP STAGE-III	REV 00	
	DOUBLE GIRDER EOT CRANES ABOVE 100T	Section	IIA Date DEC'22
STANDARD TECHNICAL REQUIREMENTS			

DOUBLE GIRDER EOT CRANE

1.0.0 SCOPE

This specification covers the design, material, manufacture, assembly, inspection and testing at manufacturer works for EOT cranes and shall be applicable unless the requirements are addressed otherwise in BHEL / BHEL's Customer approved documents.

2.0.0 CODES AND STANDARDS

The equipment to be supplied under this specification shall conform to the following codes and standards (latest revisions) unless otherwise specified hereinafter.

- | | | |
|-------|------------------|---|
| i) | IS 807 | Codes of Practice for Design, Manufacture, Erection and Testing (Structural Portion) of cranes and hoists |
| ii) | IS: 3177 | Code of Practice for Design of Overhead Travelling Cranes and Gantry Cranes other than steel work cranes. |
| iii) | IS: 2266 | Specification for steel wire ropes for general Engineering purposes. |
| iv) | IS: 4029 | Guide for testing induction motor (for temperature rise). |
| v) | IS: 15560 | Steel hooks for standard shank design. |
| vi) | IS: 3443 | Specification for crane rail section. |
| vii) | IS: 325 | Three phase induction motors. |
| viii) | IS: 900 | Code of practice for installation and maintenance of induction motors. |
| ix) | IS: 4237 | General requirement of switchgear and Control gear for voltage not exceeding 1000V. |
| x) | IS: 434 (Part I) | Copper conductors rubber insulated cables for voltage up to 1000V. |
| xi) | IS 1596 | Polyethylene insulated PVC sheathed cables |

	TITLE	SPECIFICATION NO.	PE-TS-497-501-A501
	2x660MW TALCHER TPP STAGE-III	REV 00	
	DOUBLE GIRDER EOT CRANES ABOVE 100T	Section	IIA Date DEC'22
STANDARD TECHNICAL REQUIREMENTS			

xii)	IS 3043	Code of practice Earthing
xiii)	IS: 3938	Electric Wire Rope Hoists.
xiv)	IS: 2147	Degree of protection provided by enclosures for Low voltage switchgear and control gear.
xv)	IS: 1554 Part I	PVC insulated (Heavy-duty) electric cables for working voltages up to and including 1100 volts.
xvi)	IS: 691	Flexible trailing cables rubber insulated.
xvii)	IS: 1653	Steel conduits for general engineering purposes.
xviii)	IS: 2509	Rigid non-metallic conduit for electric-Installations
xix)	IS: 2062	Steel for General Engineering purposes.
xx)	IS: 1030	Carbon Steel castings for general engineering purposes.
xxi)	IS: 1570	Schedules for Wrought steels.
xxii)	IS: 1875	Carbon steel billets, blooms, slabs and bars for forgings.
xxiii)	IS: 808	Dimensions for hot rolled steel beam, column, channel and angle sections.
xxiv)	IS: 1852	Rolling and cutting tolerances for Hot rolled steel products.
xxv)	IS: 2291	Tangential Keys and Keyways.
xxvi)	IS: 2292	Taper Keys and Keyways.
xxvii)	IS: 3961	Recommended current rating for cables.
xxviii)	IS: 694	PVC insulated cables for working voltages up to and including 1100V)
xxix)	IS: 1554 (part-I)	PVC insulated (heavy duty) electric cables: Part 1: for working voltages up to and including 1100 volts.
xxx)	IS: 4289	Flexible cables for lifts and other flexible connections: Part 1: Elastomer insulated cables.
xxxii)	BS: 970	Wrought steels in the form of blooms, billets, bars and forgings.
xxxii)	IS: 5749/ BS 3017	Specification for Forged Rams horn Hooks



TITLE 2x660MW TALCHER TPP STAGE-III DOUBLE GIRDER EOT CRANES ABOVE 100T STANDARD TECHNICAL REQUIREMENTS	SPECIFICATION NO. PE-TS-497-501-A501	
	REV 00	
	Section IIA	Date DEC'22

Indian electricity rules - 1956.

In the event of any conflict between the specification and standards mentioned above, the more stringent of the two as per interpretation of purchaser shall govern.

3.0.0 DOUBLE GIRDER EOT CRANE

3.1.0 DESIGN REQUIREMENTS

3.1.1 The crane shall be designed in accordance with the latest edition of IS-3177, IS-807 and any other standard as referred there in and subject to any modification and requirement as specified herein after.

Class of crane mechanism shall correspond to that of the crane requirement and as specified elsewhere.

3.1.2 Safety devices should be provided with all equipment/parts covered under this specification.

3.1.3 Parts requiring replacement or lubrication shall easily be accessible without dismantling the other equipment or structures. All electrical cables shall be laid to comply with recognized standards and purchaser's requirements.

3.1.4 For welded construction such as bridge girders, end carriages, rope drum, gearboxes etc. steel shall be conforming to IS-2062 quality. Welding shall be carried out only by qualified welders and subjected to NDT as specified in Quality Plan.

a. Welding shall be performed by shielded electric arc, gas or other approved methods. The electrodes used for welding shall conform to AWS A5.1.

b. Wherever lateral welding of the main plates of box girders are required, it shall be butt-welded.

c. Qualification of welding procedure and welder: These shall be carried out as per ASME Boiler and Pressure vessel code Sec. IX - Welding and brazing qualifications.

d. Electrode designations and qualifications shall be as per AWS A 5.1.

e. Electrodes should be of radiography quality with heavy covering as per IS: 814 and relevant requirement of ASME Sec IX and IIC.

f. Bare electrodes as per IS: 7280 and flux wire combination as per IS: 3613.4e

3.1.5 VOID



TITLE

2x660MW TALCHER TPP STAGE-III

DOUBLE GIRDER EOT CRANES ABOVE 100T

STANDARD TECHNICAL REQUIREMENTS

SPECIFICATION NO. PE-TS-497-501-A501

REV 00

Section IIA Date DEC'22

3.1.6 Guard shall be provided on crane to prevent the hoist ropes coming in contact with down shop leads.

Guards/ rail sweep of an approved design, which will push forward or off the track any object such as a person foot or arm, placed across it. Guards shall be attached to each end of the end carriages.

Suitable guards shall be provided to revolving shafts, coupling etc.

3.1.7 All cables shall be clamped individually. All trailing cables shall be clamped with PVC or non-metallic clamp.

3.1.8 Walkways of CT shall be of chequered plate minimum 6 mm thick O/P at least 800 mm clear inside with non-skid toe plates 8mm thick, projecting 100 mm above the floor. Walkways shall be of rigid construction and designed to sustain a distributed load of not less than 300 kg/ sq. mm.

Intermediate posts for supporting handrails shall not be spaced more than 1.5 meters apart.

Ladders provided shall have at least 450mm clear width with 20 mm rungs (rods) spaced 300 mm apart.

3.1.9 All wheels, couplings, open gear etc. shall be provided with covers.

3.1.10 All bolts except those with locknut shall be provided with grip lock nuts or spring washers.

3.1.11 Fasteners for pedestal blocks, motors, gearboxes etc. shall be easily removable from the top. Studs shall not be used as fasteners for mechanical items except for fixing covers.

3.1.12 Defects in the material like fractures, cracks, blowholes, pitting etc. are not allowed. Rectification of any such flaw is permissible only with the approval of the purchaser.

3.1.13 All parts of the crane shall be thoroughly cleaned of mill scales, rust or foreign matter and then painted as per the specification requirements.

The permissible camber shall be shown in drawing or data sheet submitted for approval.

3.2.0 STRUCTURAL DETAILS

3.2.1.0 Crane structure shall be designed in accordance with the latest edition of IS-807 after taking the following additions/deviations as applicable.

	TITLE	SPECIFICATION NO.	PE-TS-497-501-A501
	2x660MW TALCHER TPP STAGE-III	REV 00	
	DOUBLE GIRDER EOT CRANES ABOVE 100T	Section IIA	Date DEC'22
STANDARD TECHNICAL REQUIREMENTS			

- 3.2.1.1 Black bolts shall not be used in the main structure of the crane. The calculated strength of other bolted joints in structural members shall not be less than net strength of member plus 25%.
- 3.2.1.2 The calculated strength of riveted joint or joints made by friction grip bolts in structure members shall be not less than the calculated net strength of the member.
- 3.2.1.3 Bolts used in shear shall be fitted in to reamed hole.
- 3.2.1.4 Nuts and Bolts will be as per IS:1363, IS: 1364 and IS: 1367
High-tension friction grip bolts as per IS: 3757 and High- tension friction grip nuts as per IS: 6623
- 3.2.1.5 Transverse filled welding on load carrying member shall be avoided.
- 3.2.1.6 All butt welds on structural members subjected to tensile stress shall be of radiographic quality as ASME Sec VIII Div.1 acceptance norms.
- 3.2.1.7 Fillet welding on load carrying members shall be avoided.
- 3.2.1.8 For load carrying members the component plates, bars, angles and other rolled sections shall be minimum 8mm thick. For tubes having both ends sealed the minimum thickness shall be 4.9 mm (6 SWG). For unsealed tubes the minimum thickness shall be 8mm.
- 3.2.1.9 The cranes working out door or in corrosive environment, an allowance of 1.5 mm shall be added to the calculated thickness.
- 3.2.1.10 Minimum thickness of chequered plates for platform shall be over 6 mm over plain. Chequered plates shall not be considered for strength calculations of load carrying members.
- 3.2.1.11 Splice shall be designed to resist all the forces and moments to which it is subjected to plus 50% thereof.
- 3.2.1.12 However, in no case the strength developed by the splice shall be less than 50% of the effective strength of the material spliced. Splices shall be proportioned and arranged, so that the gravity axis of the splice in line with the gravity axis of the member joined so as to avoid the eccentricity of the loading.
- 3.2.1.13 The material of construction of the major components shall be as specified in the specification/data sheet. Manufacturer are however free to use alternate material material which are superior for the intended service. But in all the cases, prior concurrence of the purchaser is must.

	TITLE	SPECIFICATION NO.	PE-TS-497-501-A501
	2x660MW TALCHER TPP STAGE-III	REV 00	
	DOUBLE GIRDER EOT CRANES ABOVE 100T	Section	IIA Date DEC'22
	STANDARD TECHNICAL REQUIREMENTS		

3.2.1.14 Splices shall be designed to resist one and half times the forces and moments to which it is subjected, but in no case it shall be less than 2/3rd of the effective strength of the material spliced except that splices in the webs of the plate girders shall be designed for full strength of the web in shear as well as bending. For splicing tension members, the net section of the splice plate shall be ten percent more than that of the material spliced. Splices shall be proportioned and arranged, so that the gravity axes of the splices are in line with the gravity axis of the member to avoid eccentricity.

3.2.2 Bridge Girder

3.2.2.1 The bridge girder shall consist of a box construction with double Web plate girders or lattice girders and shall be of adequate strength to withstand the rolling loads and other stresses it is subjected to. The design of the girder shall be in accordance with latest edition of IS- 807.

3.2.2.2 Maximum deflection of the bridge girder, with safe working load, shall not exceed 1/900 of the span or as per latest IS. The girder shall be supported on the centerline of LT wheels during the deflection check. The girder shall be cambered by an amount by an amount equal to the maximum deflection.

3.2.2.3 Box section shall be adequately reinforced by internal diaphragms and ribs to withstand the most severe combination of load that may develop under different working conditions. Additional Internal diaphragms shall be provided at points where external members are welded for providing support to drives etc.

3.2.2.4 Box girders shall be provided with end plates sealing. Diaphragms inside the girder shall extend to the full - width & depth of the girder and the web plates shall be reinforced by angles all along the full length of the plates spaced midway between the diaphragms. Full depth diaphragms or stiffeners shall be furnished at bridge drive supports and below the line shaft bearings.

3.2.2.5 Short diaphragms shall be furnished and are required to transmit the trolley wheel loads to the web plates. Trolley rail section shall not be considered into design of bridge girders.

3.2.2.6 Full length chequered platforms on both side shall be provided on the side of bridge girders as specified in data sheet - A.

	TITLE	SPECIFICATION NO.	PE-TS-497-501-A501
	2x660MW TALCHER TPP STAGE-III	REV 00	
	DOUBLE GIRDER EOT CRANES ABOVE 100T	Section	IIA Date DEC'22
STANDARD TECHNICAL REQUIREMENTS			

3.2.2.7 There should not be accumulation of water/oil inside the box girders. If required breathing holes can be provided for expansion / contraction, due to change in temperature. Tapped (threaded) holes shall be provided with ½” NPT plug in the bottom of the girders, at both ends, to drain off any accumulation of water / Oil inside the girder. Instruction shall be painted on the girders to remove the plug and check for water/oil before lifting. Plug shall be replaced after installation.

3.2.2.8 All connection splices shall be designed for full strength of member of loads indicated unless otherwise approved. Beams and connections shall be designed for 60% of shear capacity of beam section plus additional axial load if any. Not more than one splice shall be provided to make up full length of number.

3.2.2.9 Maximum Span/ Depth ratio for Plate Girder shall be 25 or as per IS 807 latest edition.

3.2.3 End carriage

3.2.3.1 End carriages shall be fabricated from rolled steel section or plates. End carriage shall be of ample strength to resist all stresses likely to be imposed on them under service conditions including collision with other cranes or stops. The length of the end carriages shall be such that no other part of the crane is damaged in collision. End carriage shall be so designed as to distribute the load evenly between the wheels from each bridge girders.

3.2.3.2 The wheel base shall not be less than 1/6th of the span up to 20m, 3.5m for spans above 21m but less than 24.5m & 1/7th of span above 24.5m (as per IS 807 latest edition). End carriage shall be fitted with safety stop to prevent the end carriage falling more than 25 mm in the event of breakage of a track wheel, bogies or axle.

3.2.3.3 Suitable jacking pads at a suitable height from rail level shall be provided on each crane for crane jacking. Jacking pad dimensions shall be suitable for full seating of the jacking pad seat without any instability. When changing the track wheel, jacking pads shall not interfere with replacement of track wheel.

3.2.4 Crab (Trolley)

3.2.4.1 The crab frame shall be built from heavy steel section, welded properly to form single piece frame & to resist vertical, lateral and torsional strain and to support all loads without undue deflection. It should be properly machined to receive hoisting mechanism, cross traverse arrangement/mechanism, wheels etc. etc.

	TITLE	SPECIFICATION NO.	PE-TS-497-501-A501
	2x660MW TALCHER TPP STAGE-III	REV 00	
	DOUBLE GIRDER EOT CRANES ABOVE 100T	Section	IIA Date DEC'22
STANDARD TECHNICAL REQUIREMENTS			

3.2.4.2 Sheaves, part of hoisting mechanism, shall be so arranged on trolley that rope reeling arrangement shall ensure lifting of load in vertical line with minimum of swing or side movement. Trolley shall be provided with chequered plates all over except for opening required for ropes and equipment foundation. Equipment foundation shall not be welded/ supported on chequered plates. Toe plates 100 mm high and 6mm thick shall be provided around opening provided for movement of ropes. Suitable railing shall also be provided around the opening for rope in case the opening is large.

3.2.4.3 **Platforms and Ladders**

a) Safe means of access shall be provided to every place where any person engaged in the examination or maintenance of the crane has to work. Adequate handholds and footholds shall be provided as necessary..

b) Every platform shall be provided with steel chequered plate top and be securely fenced with 1050 mm high double tier hand rails and toe boards. Platforms shall be of sufficient width to enable normal maintenance work to be undertaken safely

c) Safety hand railing of tubular construction 32 mm NB Medium class of IS: 1239 having top and bottom rail at height of 1100 mm and 600 mm and vertical post spacing not exceeding 1500 mm with provision of kick plate (100 mm high and 6mm thick) shall be provided on bridge walkways and on end carriages, staircases, trolley and at any other place where access is provided. Bends shall be neat and made by machine. The top rail should be so laid that there is no intermediate obstruction and hand need not be lifted from rail while walking

d) In case lattice riveted construction is offered for the bridge girder, full length chequered plate platform with adequate headroom shall also be provided at bottom chord level for periodic checking of all rivets/bolts and other items.

3.2.5.0 Brief description of crane operation, Maintenance and periodical lubrication etc. typed in English and in local language neatly framed in a permanent frame for easy reference.

3.2.6.0 Suitable inspection cages to accommodate two persons to facilitate inspection of DSL.

3.3.0 **MECHANICAL**

3.3.1 **Rope drums**



TITLE

2x660MW TALCHER TPP STAGE-III

DOUBLE GIRDER EOT CRANES ABOVE 100T

STANDARD TECHNICAL REQUIREMENTS

SPECIFICATION NO. PE-TS-497-501-A501

REV 00

Section IIA Date DEC'22

Rope drums shall be of mild steel plate fabricated/ cast steel/ as per IS 3177. All fabricated rope drums shall be stress relieved. The drum shall be so designed to take full length of hoisting rope in single layers. The end of the rope shall be anchored to the drum in such a way that the charger is readily accessible. Each rope shall have not less than two (2) full turns on the drum when the hook is at lowest position not taking into consideration the turns covered by the rope in charge. One spare groove shall be provided for each rope drum when the hook is at the highest position. Each rope end shall be clamped with minimum two clamping wedges with at least two bolts on each clamping arrangement.

The pitch diameter of the drum shall be as per IS - 3177 or as specified elsewhere. The depth of the groove shall not be less than 0.35 times the rope diameter. Each rope shall be clamped to drum with two clamp wedges with at least two numbers of bolts on each clamping arrangement.

For evaluation of Radiography the designed thickness of the drum (top of crest to ID) shall be taken into consideration and not the thickness of plate selected.

3.3.2 Hoist ropes

Ropes of steel core as specified in Data sheet "A" shall be of 6x36 or 6x37 construction of extra flexible plough steel as per IS 2266 having minimum UTS of 1770 kN.

3.3.3 Rope sheaves

Sheaves shall be of cast (Castings to IS: 1030 Gr. II with Y.P. greater than 50% of UTS) or forged steel. All sheaves shall be identical, however, exception may be made for equalizer sheave. Sheave groove shall be ground finished for getting increase rope life. Equalizer sheave shall be arranged to turn and swivel in order to maintain rope alignment under all circumstances.

3.3.4 Wheels

LT & CT wheels shall be double flanged with straight tread. The wheels shall be capable of taking up misalignment in span. Solid wheel shall either be of forged steel or as specified in Data sheet. The wheel rim shall be with minimum hardness of BHN 300-350. Wheels may be either hardened on tread portion as per IS -3177 or Volume hardened. Contact stresses between wheels and rails should be within permissible limits.

	TITLE	SPECIFICATION NO.	PE-TS-497-501-A501
	2x660MW TALCHER TPP STAGE-III	REV 00	
	DOUBLE GIRDER EOT CRANES ABOVE 100T	Section	IIA Date DEC'22
STANDARD TECHNICAL REQUIREMENTS			

3.3.5 Buffer

Each End carriage shall be provided with buffer as per data sheet 'A'. Buffers should be so located that removal is not required while changing wheels or bogies. Buffers shall have sufficient tension on energy absorption capacity to bring the unloaded crane to rest from the speed of 100% of the rated speed to zero speed. Buffer is to be fitted to each end of carriage assembly and crab so that buffer contact takes place before the bridge or trolley reaches the end of rail.

3.3.6 LT drive

The bridge motion shall be achieved by suitable drive arrangement as specified elsewhere. When twin drives are used, these shall be operating in unison to avoid skewing effect. The drives shall be interlocked for simultaneous starting, stopping & speed control.

3.3.7 CT drive

Trolley drive shall be achieved by suitable drives & power shall be transmitted to the geared wheel by means of pinions mounted on both ends of the output shaft.

3.3.8. Gearing

- 3.3.8.1 Gears in speed reducer unit for bridge drive, hoists and trolley drive gearing shall be enclosed in substantial housing and shall operate in oil bath. The housing shall be of sufficient design not to permit temperature in excess of 90°C for the oil bath. Spur and helical gearing shall normally be used for all motions. Worms and bevel gears shall not be used. First high-speed reduction shall be through helical gears. All gears shall be hardened and tempered and of alloy steel with machine cut teeth 1.6 Micron finish or better and lapped with some minimum applied load to remove high spots and to improve tooth contact. Cast alloy steel is acceptable only for gears in the last stage of speed reduction. Surface hardening of teeth is not acceptable. Gear teeth shall preferably be cut in metric module system. Gears shall be designed to meet requirement of crane duty as per IS: 3177. The ratings of gears shall be established as per IS: 4660.

3.3.9 Gear Box

- 3.3.9.1 All gears shall be completely covered and enclosed in oil tight casing & sealed with gasket. In case of totally enclosed gearboxes, splash or automatic lubrication system shall be used. Covers shall be split horizontally at each shaft centre line, so that top

	TITLE	SPECIFICATION NO.	PE-TS-497-501-A501
	2x660MW TALCHER TPP STAGE-III	REV 00	
	DOUBLE GIRDER EOT CRANES ABOVE 100T	Section	IIA Date DEC'22
STANDARD TECHNICAL REQUIREMENTS			

half can be removed for inspection and repair with out disturbing the bottom half. Gear shafts shall be supported on ball/roller bearings mounted in gearbox unless specially agreed otherwise. The gear boxes shall be provided with breather, air vent, oil level indicator, dip stick, drain plug and lugs for lifting.

Radial clearance between the gear boxes inner surface and outside diameter of the gears shall be at least 1.25 times the depth of larger gear tooth inside the gear box or 20mm which ever in higher. Facial clearance between inner surface of gearbox and face of gear or pinion shall be at least 20 mm. Gearbox shall be inspected in line with QP and as per PEM (Q)/001 enclosed.

3.3.9.2 The gearboxes shall be of mild steel or cast steel. All fabricated gearboxes shall be stress relieved at a temperature between 590 to 680 deg. C. The temperature shall be maintained within ± 20 deg. C and at no time during the soaking cycle the temperature shall fall below 590 deg. C or exceed 680 deg. C. Soaking shall be done for a period proportionate to 1 (one) hour/ 2.5 cm. of wall thickness.

3.3.10 **Bearing**

3.3.10.1 Ball and roller antifriction bearing of attached sub-vendor list, make shall be used throughout, except where specified otherwise. Drive side bearing on Hoisting equipment shall be ball / roller bearing type. Rated life of ball and roller bearing shall be not less than total working life as per data sheet-A. Life of bearing shall be calculated in accordance with manufacturer's recommendations.

3.3.10.2 Provision shall be made for service lubrication of all bearings. Lubrication arrangement and clamping shall be done neatly. Bends in pipe shall be done with the help of machine. Bearing enclosures shall be designed as far as practicable to exclude dirt and shall prevent oil leakage. Accessibility should be such that parts may be safely lubricated from the walkway or ladder when the crane is not in motion.

3.3.11. **Shafts, Couplings and axles**

3.3.11.1 Shafts and axles shall be made from solid rolled or forged steel bars and shall have ample strength and rigidity and adequate bearing surface. If shouldered, they shall be provided with fillets of ample radius and /or be tapered to avoid stress concentration.

Motor shafts shall be connected to gearbox input extension shafts through flexible gear coupling. Solid coupling shall be used for connecting intermediate lengths of long travel shafts. For driving hoist drum full-gear couplings shall be used between

	TITLE	SPECIFICATION NO.	PE-TS-497-501-A501
	2x660MW TALCHER TPP STAGE-III	REV 00	
	DOUBLE GIRDER EOT CRANES ABOVE 100T	Section	IIA Date DEC'22
STANDARD TECHNICAL REQUIREMENTS			

hoists drum & hoist gearbox output shaft. Couplings shall be of cast steel/wrought steel conforming to IS: 1030 grade 280-520 and shall be designed to suit service conditions.

3.3.11.2 Self-aligning type gear couplings shall be used between connection shafts to take care of transverse as well as axial movement whenever necessary. Whenever components of considerable amount of inertia are directly mounted on the high-speed shaft (e.g. brake drum, coupling etc.) they shall be balanced statically to minimise vibration.

3.3.12 Repair Cage

A repair cage shall be provided on the inside of the end carriage for attending the main current collectors. The repair cage shall be adequately sized to accommodate two persons. And guarded for safety and correctly located for the intended service. Suitable access to the cage shall be provided. Repair cage shall be provided at the corner of the crane.

3.3.13 Lifting hook

Standard hooks shall be used unless otherwise specified. These hooks shall conform to the latest edition. All hooks used shall be in normalized condition only.

3.3.14 LIFTING HOOK BLOCK ASSY

3.3.14.1 Lifting hook block assembly shall be Ram shorn type or approved for capacity greater than 50 Tonnes and point hook with Shank for capacity below 50 Tonnes and shall be of forged steel construction. Hooks shall be manufactured from Blooms, billets, rounds by forging with forging ratio of at least 3:1. Hooks manufactured from plates are not acceptable. All hooks used shall be in normalized condition only. Each hook shall be supported on ball or roller thrust bearing and shall rotate freely.

3.3.14.2 The sheaves of the hook block shall be enclosed in a casing permitting generous lubrication of wire ropes, sheaves and also preventing accidental tapping of hands.

3.3.15 Brakes

3.3.15.1 Selection and design of brakes shall be such as to meet the requirement. Brakes shall be designed to suit 150% of torque transmitted to the brake drum with full load for hoist motions and 125% of motor rated torque before de-rating for LT/CT motion. Brakes shall be provided as specified in Data Sheet 'A'. Brake drum shall be separately mounted and coupling halves shall not be used as brake drum.

	TITLE	SPECIFICATION NO.	PE-TS-497-501-A501
	2x660MW TALCHER TPP STAGE-III	REV 00	
	DOUBLE GIRDER EOT CRANES ABOVE 100T	Section	IIA Date DEC'22
STANDARD TECHNICAL REQUIREMENTS			

i) **SERVICE BRAKE**

Double shoe types & disc type service brakes shall be provided for each motion of the crane as/or as specified in Data Sheet. The service brakes shall apply automatically when power supply to the drive motor is cut off or fails.

ii) **HOIST CONTROL**

Hoist motion shall be provided with a self-contained sturdy braking system to control the speed of hoisting as well as lowering motion. The braking system shall be reasonably uniform and effective in all loads at any position.

3.4.0 **ELECTRICAL**

3.4.1 The scope of supply shall cover all electrical equipments comprising from Main isolating switch, down shop leads, trolley conductors, current collectors etc.

3.4.1.1 Main Disconnecting/Isolating Switch fuse unit shall be provided at 1.5M above the operating floor level at one end / at both the ends of bay length or in the middle as specified in the data sheet A. Termination of incoming power supply cable to isolating switch fuse unit and further cable from switch to down shop leads shall be included in the bidder's scope of work. The switch shall be provided with Power ON Red indication lamp.

3.4.1.2 Run way conductors (Down shop leads) shrouded conductor as specified in the data sheet A shall have four conductors. One of the conductors shall be connected to earth grid for earthing connections of all electrical equipment on the crane and shall be connected to suitable collecting gear of earth conductor. Voltage drop across the down shop leads shall be less than 3% or specified in data sheet "A". It shall be supplied with brackets. Maintenance cage for DSL shall be provided on crane.

3.4.1.3 The current collectors shall be with adequate current carrying capacity and shall maintain adequate contact pressure. Spacing between current collectors shall be such as to provide sufficient quenching area for sparks coming out of collectors surface. The collector system per conductor shall spring loaded CI/carbon metallic shoes to maintain adequate contact pressure.

3.4.1.4 The cable, supplying power to crane trolley shall be flexible trailing cable as per IS-9968 Part I (latest edition) and mounted on retracting supports (festoon type).

3.4.2 **DRIVE MOTORS**

	TITLE	SPECIFICATION NO. PE-TS-497-501-A501		
	2x660MW TALCHER TPP STAGE-III			REV 00
	DOUBLE GIRDER EOT CRANES ABOVE 100T			Section IIA Date DEC'22
	STANDARD TECHNICAL REQUIREMENTS			

- 3.4.2.1 Crane Motors shall be totally enclosed, fan cooled and as per data sheet 'A'. The starting torque of motor shall not be less than 2.25 times the rated torque and pull out torque shall not be less than 275% of the rated full load torque of motor. In case of VVVF drive system, the creep speed will be achieved through VVVF drives and the motors for Main hoists, Auxiliary hoist, CT and LT will be Squirrel cage. Hoisting drive motors shall be provided with antifriction roller / ball bearings on the drive side.
- 3.4.2.2 Ambient correction factors as well as voltage /frequency correction factors depending up on the ambient temperature and voltage /frequency variation shall be applied to de-rate the motors. The minimum margin of 10% shall be considered over the calculated rating of the motor. The protection class of the motors shall be as IP-55. Motors shall be tested at manufacturer's works in accordance with IS-325/as per agreed Quality plan & Reports shall be submitted for approval. Motors shall comply with the requirement of IS-325 or as per the motor spec.
- 3.4.2.3 All the motors shall be provided with lifting lugs two earth terminals of adequate size to accept the earthing conductors shall be provided at diametrically opposite points unless specifically designed For higher speeds, motors shall be capable of with-standing 2.5 times the rated speed.
- 3.4.2.4 Motors shall be painted in line with painting instructions specified in Painting Scheme Annexure IV attached along with the technical specification.
- 3.4.3 **Limit switches**
The hoist mechanism of the crane shall be provided with rotary type limit switch to open the control circuit & in order to prevent the crane hook from over hoisting and over lowering, one gravity type back up limit switch of hand reset type shall also be provided. This switch will operate in the event of failure of main limit switch. Lever operated limit switches shall be provided at both ends of longitudinal travel and cross traverse. These limit switches shall be self-reset type. The limit switches shall be as per "Data Sheet A"
- 3.4.4 **Switch**
All switches shall be hand operated; air break, heavy duty, quick make and quick break type. Incoming supply disconnect switch shall be interlocked with panel door so that the same cannot be opened unless the switch is in OFF position. Safety Interlocks-Disconnect Switch-The operating handle of the main/ safety disconnect

	TITLE	SPECIFICATION NO.	PE-TS-497-501-A501
	2x660MW TALCHER TPP STAGE-III	REV 00	
	DOUBLE GIRDER EOT CRANES ABOVE 100T	Section	IIA Date DEC'22
STANDARD TECHNICAL REQUIREMENTS			

switch shall be mechanically interlocked with enclosure cover such that the same cannot be opened unless the switch is in OFF position. Main/ safety disconnect switch shall have provision of pad locking in OFF position

3.4.5. **Contactors.**

Contactors shall be suitable for heavy duty, with current rating not less than connected motor full load current. All reversing contactors shall be mechanically and electrically interlocked.

Each contactor shall be provided with three positive acting ambient temp. Compensated thermal overload relay with adjustable setting to suit the motor current. The relay shall be hand reset type, suitable for current. The relays shall be replaceable from front. The main contactor shall be electrically interlocked so that it cannot close unless all the motor overload relays are RESET and all controllers are in OFF position. The main contactor shall be also opened by means of emergency push buttons and hoist limit switches.

3.4.6 **Push button and lamp**

Push button shall be spring return type with 2 NO + 2 NC contacts, rated 10A, 240 V AC. Indicating lamps and lens shall be replaceable from front.

3.4.7 **Protective Panel**

- 3.4.7.1 The electrical protective panel shall be a cubicle fabricated from Cold rolled sheet steel not less than 2.5mm for front & rear & 2mm for side, top & bottom portion with gland plate of 3mm thick with lockable-hinged door. The control cabinet's door shall be interlocked with the operating handles of isolating switches of supply circuits so as to prevent opening of the door when an isolating switch is closed. A device for bypassing the interlock shall also be provided. It shall be dust and vermin proof with degree of protection as IP-54 or as specified in data sheet A. All the equipment inside the panel shall have permanent identification. The panels shall be front connected type with front-hinged door for access to wiring and terminals. Engraved nameplate shall be furnished for all panels and also for the equipment and devices mounted there on.

The following minimum equipment shall be provided.

- One triple pole air break type main contactor with thermal overload relay.
- One triple pole main line connecting/disconnecting switch.

	TITLE	SPECIFICATION NO.	PE-TS-497-501-A501
	2x660MW TALCHER TPP STAGE-III	REV 00	
	DOUBLE GIRDER EOT CRANES ABOVE 100T	Section	IIA Date DEC'22
STANDARD TECHNICAL REQUIREMENTS			

- c) Emergency push button at convenient height for the operation for interruption of the entire power.
- d) Thermal overload relay for each drive. It shall be ambient temperature compensated and adjustable type.
- e) Contactors, timer and auxiliary contactors.
- f) Portable Lighting Transformer rated for 415/24V.
- g) Lighting Voltage Transformer with fuse 415/24V.
- h) Control transformer with fuses.
- i) Indicating lamps to indicate the live condition of all three phases.
- j) Main supply ON/OFF lamps on the door of the protective panel.
- k) Electrical interlock shall be provided to prevent the main contactor being closed unless all controllers are in OFF position.
- l) Other equipment as per supplier's standard practice. Air break contactors shall conform to category AC-4 duty. The main contacts shall have the rating for 5 Amps or as specified in the data sheet A. The contactor drop off voltage shall be between 45-50% of rated voltage.
- m) All internal wiring shall be identified with numbering rules at both ends as per the relevant wiring diagram.
- n) Each panel shall have internal illumination with fluorescent lamp. The inside of the panel shall be painted white.
- o) Separate terminal blocks shall be provided for terminating circuits of various voltage classes. At least 20% spare terminals for the wire terminations shall be provided in the cabinet.

3.4.8 Starter Panel

Separate panels shall be provided for CT, LT & hoist motion (Main and Auxiliary), with following type of items.

- a) Contactors : AC4 duty for reversing applications
AC3 duty for non-reversing applications
- b) Switches : AC23 for motor application.
AC22 for other application
- c) Fuses : HRC

	TITLE	SPECIFICATION NO.	PE-TS-497-501-A501
	2x660MW TALCHER TPP STAGE-III	REV 00	
	DOUBLE GIRDER EOT CRANES ABOVE 100T	Section	IIA Date DEC'22
STANDARD TECHNICAL REQUIREMENTS			

d) Overload relays: Temperature compensated bi-metallic
with single phasing preventer.

3.4.9 MOTOR CONTROL PANEL

The motor control panels shall be dust and weatherproof to IP-54/55 or as specified in "Data Sheet A" & shall be provided separate for each motion. The panel shall contain minimum the following components.

- a) Switch fuse unit with contacts of adequate rating for each motion.
- b) Thermal overload relay for each drive. These shall be ambient temperature compensated adjustable type.
- c) Contactors, timers and auxiliary contactors.
- d) The panel shall be provided with space heater. The space heater with thermostat shall be located at the bottom of the panel and shall have individual ON/OFF switch.
- e) Terminal blocks shall be stud or snap on type. A protective cover shall be fixed on top of terminal blocks to prevent accidental contact. A minimum of 20% spare terminals shall be provided.
- f) Air break contactors shall be provided for main supply as well as for motors. They shall conform to category AC-4 as per IS-1322. These shall have three main contacts and 2 No. & 2 NC auxiliary contacts.
- g) The main contacts shall have the ratings as per duty requirement but auxiliary contact shall be rated for 5 amp 240V AC. The contactor drop off voltage shall be between 45-50% of rated voltage. The contactor coil shall be suitable for 240V AC supply.
- h) The auxiliary contactors shall have 4 No. + 4 NC contacts for control and interlocking purposes. The contacts shall be convertible. The contacts rating shall be suitable for 5 amps at 240 Volts AC.
- i) Adequate protection for overload and short circuit shall be provided for all the three phases of each motor.
- j) Double pole switch fuse unit for control circuit of the contractor 'START (push button and a pilot lamp with the red lens for indicating the contactor "CLOSED" shall be furnished.

3.4.11 Illumination

	TITLE	SPECIFICATION NO.	PE-TS-497-501-A501
	2x660MW TALCHER TPP STAGE-III	REV 00	
	DOUBLE GIRDER EOT CRANES ABOVE 100T	Section	IIA Date DEC'22
STANDARD TECHNICAL REQUIREMENTS			

Crane lighting and space heating system shall be de- signed for 240V, 1Phase 50Hz supply and receptacle system with 24V 1Phase 50Hz supply or as specified in the Data sheet A. Suitable dry type transformers shall be furnished for this purpose, complete with isolation facility and Primary/secondary fuses.

- a) Branch Circuits for lighting and receptacles shall be individually protected by switch fuse units.
- b) CFL fixtures shall be used for lighting operator's cabin and bridge platform.
- b) 60W bulkhead fittings with fluorescent lamp shall be used for lighting bridge platform.
- c) Four (4) no.s - 250 W HPSV lamps shall be provided under the bridge as specified in the data sheet "A"
- d) All lighting fixtures shall be mounted with anti-vibration mounting and shall be easily accessible for maintenance.
- e) 24V - 5A - 3 pin industrial socket outlets shall be provided. Minimum four (4) on the bridge along the walk way on both sides of full length platforms.
- f) One (1) portable 40 W hand lamp with min. half span length flexible cable for inspection of crane components.

3.4.13 **Grounding**

3.4.13.1 The crane structure, motor frame and all other electrical equipment/s shall be grounded in accordance with the Indian Electricity Rules. The connections from Crane Bridge to 4th conductor of down shop leads shall be by means of current collector.

3.4.13.2 The equipment fed by flexible cables shall be grounded by means of fourth core provided in the flexible trailing cable. Pendant push button station shall be earthed Separately.

3.4.14 Red warning light 3 Nos. shall be provided at both ends of the gantry girder to indicate the aliveness of DSL.

3.4.15 **Wiring Systems**

- a) All electrical equipment, accessories and wiring shall have tropical protection involving special treatment of insulation and metal against fungus, insects and corrosion. All cabling shall be carried out using XLPE insulated fire resistant (FRLS) cables & wiring by Heat resistance PVC wires with stranded conductor
- b) All wiring shall be done with 1100V grade fire resistance PVC insulated wire in conduits or by 1100V grade PVCA PVC cables with extruded inner sheath.

	TITLE	SPECIFICATION NO.	PE-TS-497-501-A501
	2x660MW TALCHER TPP STAGE-III	REV 00	
	DOUBLE GIRDER EOT CRANES ABOVE 100T	Section	IIA Date DEC'22
STANDARD TECHNICAL REQUIREMENTS			

- c) For selecting the cable rating, cable for power wiring, consideration shall be given to the motor duty, ambient temperature grouping and disposition of the cables voltage drop etc.
- d) Armoured cables or un-armoured running through the flexible conduits may be used for power wiring / control and auxiliary circuit wiring shall run through flexible conduits.
- e) Each motor shall be wired independently. Power and control wiring shall be effectively separated.
- f) Each wire shall be identified at both ends with wire designation in accordance with circuit wiring diagram.
- g) All wire termination to the panels shall be provided with clamp type connections screw. Screw Type terminals with screw directly impinging on conductors are not acceptable.
- h) Multi way terminal blocks complete with screw nut, washer and marking strips shall be furnished for terminating the panel wiring.
- i) Not more than two wires shall be connected to any terminal on either side of terminal block. If necessary number of terminals shall be jumped together to provide the wiring points
- j) Each terminal block shall be marked with designation in accordance with conductors wiring diagram.



TITLE

TECHNICAL SPECIFICATION
FOR VVVF DRIVE

SPECIFICATION NO. PE-TS-XXX-501-A002

VOLUME II - B

SECTION II B

Rev 00

1 OF 5

1.0 General

- a) This part of the specification describes the general requirements for the Variable Voltage Variable frequency Drives, herein referred to as AC Drives, for use with standard IEC design AC squirrel cage induction motors. The nominal values, the standard documents and the drive's minimum performance are defined in this part. **To avoid any mismatch between the motor and its control equipment, the AC Drive shall be capable of auto adjustment by automatic measurement of the motor parameters with/without motor rotation.**

- b) Inverter construction and related devices:

Construction shall be divided in 3 broad sections. Section one converts AC Supply into DC supply. Section 2 Converts and controls DC supply into AC Supply with regulation. Section 3 shall be used for braking action of the motor and Dynamic Braking Unit (DBU) can be inbuilt or external depending upon the drive capacity. VVVF can be used in open loop (without external speed feed back) like in Travel motions or close loop (With external speed feed back) like in Hoist motions. Chokes on input supply side are generally used in crane application for power regulation. Like all other electronic / electric devices VVVF drives are also protected by MCB / MCCB / Fuses. VVVF drives are sensitive to temperature and hence drive internal as well as external cooling fans are provided.

- c) Programming of VVVF Drives.

VVVF drives shall be programmable and for that purpose detachable digital Operator display unit shall be supplied along with the VVVF having required buttons for setting the user constant, functions etc. The VVVF drive is to be fine tuned by matching the motor parameters and setting the parameters on full load.

- d) VVVF drives shall be connected with power supply and these drives generate their own low voltage control supply. Potential free contacts shall be connected to this control supply and few programmable control terminals. Starting / stopping / set speeds operations of VVVF drive shall be achieved by above control connection.
- e) VVVF shall give smooth control over acceleration and deceleration making the motion jerk free and using Variable voltage variable frequency limits the inrush current to the squirrel cage motors. VVVF provides controlled torque to the motor due to which crane operations are jerk free.

1.1 Experience

The Frequency Converter Manufacturer shall have adequate experience in frequency converter manufacturing and have adequate business volume in order to provide credibility in his commitments and a capability of long term support.

1.2 Local support



TITLE

**TECHNICAL SPECIFICATION
FOR VVVF DRIVE**

SPECIFICATION NO. PE-TS-XXX-501-A002

VOLUME II - B

SECTION -D

Rev 00

2 OF 5

The Supplier shall have a permanent representative office with a trained and skilled support staff, in the country where the goods are delivered, in order to prove his commitment for local support and to provide a channel for communication.

The engineers employed by the Supplier's regional office shall be certified by the Manufacturer and provide start-up service including physical inspection of the drive, connected wiring and final adjustments, to ensure that the AC Drive meets the required performance.

The Supplier shall be able to give basic drives training to the Customer's engineers, preferably on the site. The training shall, as a minimum, include system concepts and basic troubleshooting.

2.0 Basic requirements for the AC Drives

2.1 General requirements

The AC Drive shall comply with National(country of origin) and International standards and the recommendations for electrical industrial control devices (IEC, EN, UL, NFC, VDE).

The AC Drive shall be of the most modern design, yet user friendly and be simple to install, commission and maintain. The AC Drive shall be able to start and control the speed of a standard squirrel cage induction AC motor. The AC Drives shall be : CE marked, conforming to European Low Voltage (73/23/CEE and 93/68/CEE) and EMC (89/336/CEE) Directives, UL/CSA marked according to UL 508C.

The AC Drives have to be built to comply with the IEC standards.

The AC Drive shall be a digitally controlled drive, using, at least, the Pulse Width Modulation (PWM) with flux vector control open loop(for travel) and closed loop(for hoist). It shall have diodes / thyristors in rectifier and IGBT's in the inverter section in their entire power range, and it shall have the following minimum specifications.

Rated Input Voltages	380V -15% 480V +10%, three-phase
Rated Input Frequency	50Hz +/- 5%
Output Voltage	0 – Input voltage, three-phase
Output Frequency Range	0 to 400 Hz
Acceleration / Deceleration Time	0.01 – 999s, adjustable, linear, with S, with U or customised shapes
Overload capability (Constant Torque)	150% of nominal current for 1min.
Operating ambient Temperature	-10°C up to 50°C(shall be derated suitably)



TITLE

**TECHNICAL SPECIFICATION
FOR VVVF DRIVE**

SPECIFICATION NO. PE-TS-XXX-501-A002

VOLUME II - B

SECTION -D

Rev 00

3 OF 5

	if not rated at 50°C)
Storage ambient Temperature	-25°C up to 70 °C
Maximum operating altitude	1000 m without de-rating, 1000...3000 (shall be de-rated suitably)
Max. Relative Humidity	95 %, without condensation and dripping water.
Main Protections	Over current, short circuit between phase, short circuit between phase and ground, input phase loss, output phase loss, motor overload, over speed, over voltage, under voltage, drive over temperature

The AC Drive shall be able to give a 100 % output current continuously in the above specified conditions. In order to ensure that the drive can provide the required output current in the specified ambient conditions, the Manufacturer shall inform the required derating, if the ambient temperature given in the project-specific specification is higher than rated ambient of the drive or if the installation altitude is more than 1000 m above the sea level. The de-rating factor shall be specified so that neither the lifetime of the AC Drive nor the unit's performance, overload capability included, nor the reliability of the AC Drive shall suffer.

The VVVF drives shall have all necessary protections i.e input phase loss, earth fault, over voltage, output short circuit, load loss , input transient protection, overload etc

Suitable encoder shall be provided for all motions.

3.0 User interface

3.1 General

The user interface shall be identical throughout the power range and type to avoid confusion amongst the users and need for training in several different units.

3.2 Inputs and outputs

A. At least, the following standard Inputs and Outputs shall be provided, to be used in interface with the control system:

Analogue Inputs	:	1 x Programmable differential voltage input $\pm 10V$, 1 x Programmable current input 0(4) - 20mA 1 x Programmable voltage input 0 – 10V
Analogue Output	:	1 x Programmable analogue outputs 0(4) - 20mA or 0 – 10V
Logic inputs	:	6 x Programmable logic Inputs isolated from the mains



TITLE

**TECHNICAL SPECIFICATION
FOR VVVF DRIVE**

SPECIFICATION NO. PE-TS-XXX-501-A002

VOLUME II - B

SECTION -D

Rev 00

4 OF 5

Relay Outputs : 2 x Programmable Digital outputs with a changeover dry contact

All the control terminals shall be clearly marked.

B. At least, it shall be possible to assigned the following functions to the I/Os:

Analogue input	Analogue outputs
Speed reference Summing reference	Motor current Motor frequency Motor torque Motor power
Logic input	Relay or logic outputs (open collector)
Forward Reverse Jog Preset speeds Reference switching Ramp switching Parameter sets selection Fast stop Freewheel stop + speed - speed External fault	Ready Drive running High speed attained Drive fault Frequency threshold attained Motor thermal state attained Torque or current limitation attained Brake control

3.4 Programming terminal

- A. The AC drive shall have a keypad /display for programming and controlling purposes. An IP54 or IP65 remote mounting shall be possible at a distance of 10m.
- B. Password protection shall be provided to avoid unauthorized tampering with the set parameters.
- C. The programming terminal shall be able to display the commercial reference of the AC drive and of the options, the software version, the serial number
- D. Direct keypad entry shall be provided to observe the following actual parameters. Any one of the following parameters or actual values shall be selected to be always displayed:-
- Input Voltage
 - Input Frequency
 - Output Frequency
 - Output Power
 - Output Current



TITLE

TECHNICAL SPECIFICATION
FOR VVVF DRIVE

SPECIFICATION NO. PE-TS-XXX-501-A002

VOLUME II - B

SECTION -D

Rev 00

5 OF 5

vi) Motor Speed

The following parameters shall always be displayed during normal operation:-

i) Drive Status

The following drive control functions at least shall be available from the keypad:-

- i) Run
- ii) Stop
- iii) Local / Remote selection.
- iv) Forward/Reverse (if function enabled)
- v) Accelerate
- vi) Decelerate
- vii) Parameter setting

3.5 Application programming

The AC Drive shall be designed for both simple and the most complicated applications, yet it shall be user friendly. It shall be possible to reset the parameter settings back to the original factory settings through the keypad.

3.6 PC Tools

The AC Drive Supplier shall have a Windows based PC software available for monitoring and controlling the AC Drives, and the software shall be offered as an option. The software shall be supplied with the necessary hardware and a provision for connecting a PC with the AC Drives. It shall be possible to set and modify parameters, control the drive, read actual values and make trend analysis using the software.

4.0 Software features

A. Restart

In the event of a fault trip due to over voltage, over current or loss of analogue signal, the AC DRIVE shall be programmable to attempt an automatic restart. For safety reasons, the maximum number of attempts shall be within a selectable time. If the fault does not clear after the attempts, the drive shall lock out.

B. Brake logic control

The AC Drive shall have a built-in function to control a mechanical brake in order to move the load in a smooth and safe way. The brake logic control shall be adapted to the different movements, hoisting, travel, and orientation.

5.0 Preferred makes:

As per attached sub-vendor list

1236340/2023/PS-PEM-MAX



TITLE

2x660MW TALCHER TPP STAGE-III**DOUBLE GIRDER EOT CRANES ABOVE 100T****STANDARD TECHNICAL REQUIREMENTS**

SPECIFICATION NO.

REV 00

Section II

SECTION – II**Site Storage and Preservation Guidelines**

CONTENT

- 1 SCOPE OF THE DOCUMENT
- 2 PURPOSE OF STORAGE & PRESERVATION
- 3 MEASURES TO BE TAKEN FOR STORAGE AND PRESERVATION
 - a) GENERAL STORAGE REQUIREMENTS
 - b) GENERAL PRESERVATION REQUIREMENTS
 - c) GENERAL INSPECTION REQUIREMENTS
- 4 TYPE OF STORAGE FOR VARIOUS EQUIPMENT
5. CONCLUSION
6. STACKING ARRANGEMENT FOR PLATES AND STRUCTURAL STEEL

1. SCOPE OF THE DOCUMENT

This guideline is prepared in intent to provide proper site storage and preservation of the Mechanical, Electrical and C & I items / equipment supplied under various bought out packages/items. This storage procedure shall be followed at different power plant sites by concerned agency for storage and preservation from the date of equipment received at site until the same are erected and handed over to the customer.

2. PURPOSE OF STORAGE & PRESERVATION

Many of the items may be required to be kept in stores for long period. It shall therefore be essential that proper methods of storage and preservation be applied so that items do not deteriorate, loose some of their properties and become unusable due to atmospheric conditions and biological elements.

3. MEASURES TO BE TAKEN FOR STORAGE, HANDLING & PRESERVATION

a) GENERAL STORAGE REQUIREMENTS

1. To the extent feasible, materials should be stored near the point of erection. The storage areas should have adequate unloading and handling facilities with adequate passage space for movement of material handling equipment such as cranes, fork lift trucks, etc. The storage of materials shall be properly planned to minimise time loss during retrieval of items required for erection.
2. The outdoor storage areas as well as semi-closed stores shall be provided with adequate drainage facilities to prevent water logging. Adequacy of these facilities shall be checked prior to monsoon.
3. The storage sheds shall be built in conformity with fire safety requirements. The stores shall be provided with adequate lights and fire extinguishers. 'No smoking' signs shall be placed at strategic locations. Safety precautions shall be strictly enforced.
4. Adequate lighting facility shall be provided in storage areas and storage sheds and security personnel positioned to ensure enforcement of security measures to prevent theft and loss of materials.
5. Adequate number of competent stores personnel and security staff shall be deployed to efficiently store and maintain the equipment / material.
7. The equipment shall be stored in an orderly manner, preserving their identification slips, tags and instruction booklets, etc., required during erection. The storage of materials shall be equipment-wise. Loose parts shall be stored in sheds on racks,

preserving the identification marks and tags in good condition. The group codes shall be displayed on the racks

6. At no time shall any materials be stored directly on ground. All materials shall be stored minimum 200 mm above the ground preferably on wooden sleepers

b) GENERAL PRESERVATION REQUIREMENTS

1. All special measures to prevent corrosion shall be taken like keeping material in dry condition, avoiding the equipment coming in contact with corrosive fluid like water, acid etc.
2. Materials which carry protective coating shall not be wrapped in paper, cloth, etc., as these are liable to absorb and retain moisture. The material shall be inspected and in case of signs of wear or damages to protective coating, that portion shall be cleaned with approved solution and coated with an approved protective paint. Complete record of all such observations and protective measures taken shall be maintained.
3. Generally equipment supplied at site are properly greased or rust protective oil is applied on machined/ fabricated components. However periodic inspection shall be carried out to ensure that protection offered is intact.
4. While handling the equipment, no dragging on the ground is permitted. Avoid using wire rope for lifting coated components. Use polyester slings (if possible) otherwise protective material (e.g. clothes, wood block etc.) should be used while handling the components with rope / slings
5. For Equipment supplied with finished paint, touch paint shall be done in case any surface paint gets peeled off during handling. Otherwise such surfaces shall necessarily be wrapped with polythene to avoid any corrosion. Further for equipment wherein finish coat is to be applied at site, site to ensure that equipment is received with primer coat applied.
6. It shall be ensured by periodic inspection that plastic inserts are intact in tapped holes, wherever applicable.
7. Pipes shall be blown with air periodically and it shall be ensured that there is no obstruction.
8. Silica gel or approved equivalent moisture absorbing material in small cotton bags shall be placed and tied at various points on the equipment, wherever necessary.
9. Heavy rotating parts in assembled conditions shall be periodically rotated to prevent corrosion/jamming due to prolonged storage.

10. All the electrical equipment such as motors, generators, etc. shall be tested for insulation resistance at least once in three months and a record of such measured insulation values shall be maintained.
11. Following preservatives/preservation methods can be used depending upon type of equipment
 - a. Rust preventive fluid (RPF)
 - b. Rust protective paints
 - c. Tarpaulin covers, in case of outdoor storage
 - d. De-oxy aluminate for weld-ments

c) GENERAL INSPECTION REQUIREMENTS

1. Period inspection of materials with specific reference to –
 - Ingress of moisture and corrosion damages.
 - Damage to protective coating.
 - Open ends in pipes, vessels and equipment -
 - In case any open ends are noticed, same shall be capped.
2. Any damages to equipment / materials.
 - In case of any damages, these shall be promptly notified and in all cases, the repairs / rectification shall be carried out.
 - Any items found damaged or not suitable as per project requirements shall be removed from site. If required to store temporarily, they shall be clearly marked and stored separately to prevent any inadvertent use.

4. TYPE OF STORAGE FOR VARIOUS EQUIPMENT

The types of storage are broadly classified under the following heads:

i **Closed storage with dry and dust free atmosphere. (C)**

The closed shed can be constructed by using cold-rolled / tubular components for structure and corrugated asbestos sheets / galvanised iron sheets for roofing. Brick walls / asbestos sheets can be used to cover all the sides. The floor of the shed can be finished with plain cement concrete suitably glazed. The shed shall be provided with proper ventilation and illumination.



ii **Semi-closed storage. (S)**

The semi closed shed can be constructed by using cold-rolled / tubular components for structure and corrugated / asbestos sheets for roofing. The floor shall be brick paved. If required a small portion of sides can be covered to protect components from rainwater splashing onto the components.





iii Open storage (O)

The open yard shall be levelled, well consolidated to achieve raised ground with the provision of feeder roads for crane approach along with access roads running all sides. One part of the open yard shall be stone pitched, levelled and consolidated with raised ground suitable for storing / stacking heavier and critical components with due space to handle them by cranes etc . Adequate number of sleepers, concrete block etc. to be provided to make raised platforms to stack critical materials.

A separate yard to be identified as “scrap yard” slightly away from main open yard to store wooden/steel scraps, which are to be disposed off. This is required to avoid mix up with regular components as well as to avoid fire hazard.

Some of the components, which are having both machined & un-machined surfaces and are bulky, shall be stored in open storage area on a raised ground and suitably covered with water proof / fire retardant tarpaulin.



1236340/2023/PS-PEM-MAX

The equipment listed below shall be stored and inspected as per requirement mentioned in the table below.

Sl. No.	Description of the equipment	Type of Storage	Check for	Remarks
Raw material /mechanical items like pipes, plates, structure sections etc.)				
1.	Steel pipes (lined/unlined)	S	Damage , paint, corrosion, rubber lining peeling	Provide end cap
2.	MS Plates	S	Damage, paint, corrosion	
3.	SS Plates	S	Damage	
4.	Non-metallic pipes	S	Damage, cracks	Provide end cap
5.	Stainless steel pipes	S	Damage ,	Provide end cap
6.	MS sections, beams	S	Damage, paint, corrosion	
7.	Cable trays	S	Damage, condition of preservations	
8.	Insulation sheets	S	Damage	
9.	Insulation	C	Damage, packing	
10.	Hangers Rods	S	Damage, paint, packing	
11.	Tubes	S	Damage, paint , packing	Provide end cap
12.	Hume pipes	O	Damage	
13.	Castings	O	Damage, paint, corrosion	
Fabricated mechanical items (pressure vessels, tanks etc.)				
14.	Pressure vessels (unlined)	O	Damage, paint, corrosion,	Covered nozzles
15.	Atmospheric storage tanks (unlined)	O	Damage, paint, corrosion	Covered nozzles

Sl. No.	Description of the equipment	Type of Storage	Check for	Remarks
16.	Pressure vessels (lined)	S	Damage, paint, corrosion, rubber lining	
17.	Atmospheric storage tanks(lined)	S	Damage, paint, corrosion, rubber lining	
18.	Support structures	O	Damage , paint, corrosion	
19.	Flanges	C	Damage , paint, corrosion	
20.	Fabricated pipes	S	Damage , paint, corrosion	Provide end cap
21.	Vessels internals	C	Damage , paint, corrosion ,packing	
22.	Grills	S	Damage , paint, corrosion	
23.	Angles	S	Damage , paint, corrosion	
24.	Bridge mechanism/clarifier mechanism	O	Damage , paint, corrosion	
25.	Cranes, rails	S	Damage , paint, corrosion	
26.	Stair cases	O	Damage , paint, corrosion	
27.	Ladders/handrails	O	Damage , paint, corrosion	
28.	Fabricated ducts	S	Damage , paint, corrosion	
29.	Isolation Gates	O	Damage , paint, corrosion	
30.	Fabricated boxes/panels	S	Damage , paint, corrosion	
Mechanical components like valves, fittings, cables glands, spares etc.)				
31.	Valves	S	Damage , packing	

Sl. No.	Description of the equipment	Type of Storage	Check for	Remarks
32.	Fittings	S	Damage , packing	Provide end cap
33.	Cable glands	C	Damage , packing	
34.	Tools & tackles	C	Damage , packing	
35.	Nut , bolts, washers,	C	Damage , packing	
36.	Gasket & Packings	C	Damage , packing	
37.	Copper tubes	C	Damage , packing, corrosion	Provide end cap
38.	SS tubing	C	Damage , packing	Provide end cap
Rotating assemblies (pumps, blowers, stirrers, fans, compressors etc.)				
39.	Pumps	S	Damage , packing, corrosion	Shaft rotation
40.	Blowers/Compressors	S	Damage , packing, corrosion	Shaft rotation
41.	Agitators/stirrers/radial launders	C	Damage , packing, corrosion	Shaft rotation
42.	Rollers for chlorine tonner mounting	C	Damage , packing, corrosion	
43.	Centrifuge	S	Damage , packing,	
44.	Gear box	C	Damage , packing, corrosion	
45.	Bearings	C	Damage , packing, corrosion	
46.	Fans	S	Damage , packing, corrosion	
47.	Dosing skids	S	Damage , packing, corrosion	
48.	Pump assemblies	S	Damage , packing, corrosion	
49.	Air washers(INTERNALS)	S	Damage , packing	
50.	Air conditioners (split)	C	Damage , packing	

Sl. No.	Description of the equipment	Type of Storage	Check for	Remarks
51.	Elevators(CONTAINERIZED)	O	Damage , packing, corrosion	
52.	Chillers/VA machines	S	Damage , packing	
53.	Air handling Unit/Package unit	S	Damage , packing	
54.	Chlorinators & Evaporators	C	Damage , packing	
55.	Ejectors	C	Damage , packing	
56.	Electrolyser	C	Damage , packing	
Miscellaneous items like chain pulley blocks, hoists etc.				
57.	Chain pulley blocks	S	Damage, Packing	
58.	Electric hoists	S	Damage, Packing	
59.	Fire extinguishers	C	Damage, expiry date	
60.	Fork Lift Truck	S	Damage, Packing	
61.	Hydraulic Mobile Crane	O	Damage, Packing	
62.	Mobile Pick Up & Carry Crane	O	Damage, Packing	
63.	Motor boats	O	Damage, Packing	
64.	Safety showers	S	Damage, Packing	
65.	Diffusers/dampers	S	Damage, Packing	
Chemicals and consumables (acid, alkali, paints, oils, reagents and special chemicals)				
66.	Hydro Chloric Acid (HCl)	Store in canes/ storage tank in dyke area	Date of production/ leakage/fumes	hazardous chemical
67.	Sulphuric acid (H ₂ SO ₄)	Store in canes/ storage tank in dyke area	Date of production/ leakage/fumes	hazardous chemical

Sl. No.	Description of the equipment	Type of Storage	Check for	Remarks
68.	Sodium hydroxide (NaOH)	Store in canes/ storage tank in dyke area	Date of production/ leakage/ fumes/ breather	hazardous chemical ,breather to be checked for air ingress
69.	Sodium hypo chlorite	To be stored under shed	Date of production/ leakage/ fumes	hazardous chemical ,self-life normally 15-30 days after which strength of chemical decays
70.	Ammonia	S	Date of production/ leakage/ fumes	Store in closed storage tanks, hazardous chemical
71.	CW treatment chemicals	S	Date of production , Self-life	Store in closed canes
72.	RO/UF cleaning chemicals	S	Date of production , Self-life	Store in closed canes
73.	Lime	C	Damage to packing , seepage	Prevent moisture, rain
74.	Alum bricks	C	Damage to packing	Prevent moisture, rain
75.	Poly electrolyte	S		Store in closed storage tanks
76.	Laboratory chemicals(powder)	C	Damage, Packing self- life	
77.	Laboratory chemicals(liquid)	C	Damage, Packing self- life	
78.	Lubrication oils	C	Leakage	
79.	Paints	S	Leakage ,air tightness	
80.	Sand	O	Damage of packing	No hooks
81.	Salt (NaCl)	C	Damage of packing, water ingress	Prevent moisture, rain
82.	Anthracite	S	Damage of packing	
83.	Activated carbon	S	Damage of packing	

Sl. No.	Description of the equipment	Type of Storage	Check for	Remarks
84.	Thermal insulation	S	Damage of packing	
85.	Cement	C	Damage of packing	Prevent moisture, rain
86.	Gravels	O	Damage of packing	
87.	ION exchange resins	C	Damage , packing	Refer manufacturer guidelines
88.	RO membranes	C	Damage , packing	Refer manufacturer guidelines
89.	UF membranes	C	Damage , packing	Refer manufacturer guidelines
90.	Cleaning chemicals	C	Damage , packing	Refer manufacturer guidelines
91.	Chemicals for analysers/calibration	C	Damage , packing	Refer manufacturer guidelines
Electrical and C & I items (motors, cables etc.)				
92.	Motors	C	Damage , packing	
93.	Cable drums	O	Damage	
94.	Control Panel /control desk, UPS ,JB	S	Damage, Packing	
95.	Instruments(gauges/analysers)	C	Damage	
Special items		As per Manufacturer's item, like Hydrogen cylinders, Ozonator, Analyser, Chlorine dioxide generators etc.		

5. CONCLUSION

Concerned storage agency at site should make sure that loss in equipment performance and wear & tear are minimised through proper storage and preservation. The above are broad guidelines and cover major equipment / materials. However specific storage practices shall be followed as per manufacturer recommendation. All the necessary measures even in addition to the ones mentioned above, if found necessary, should be taken to achieve the objective.

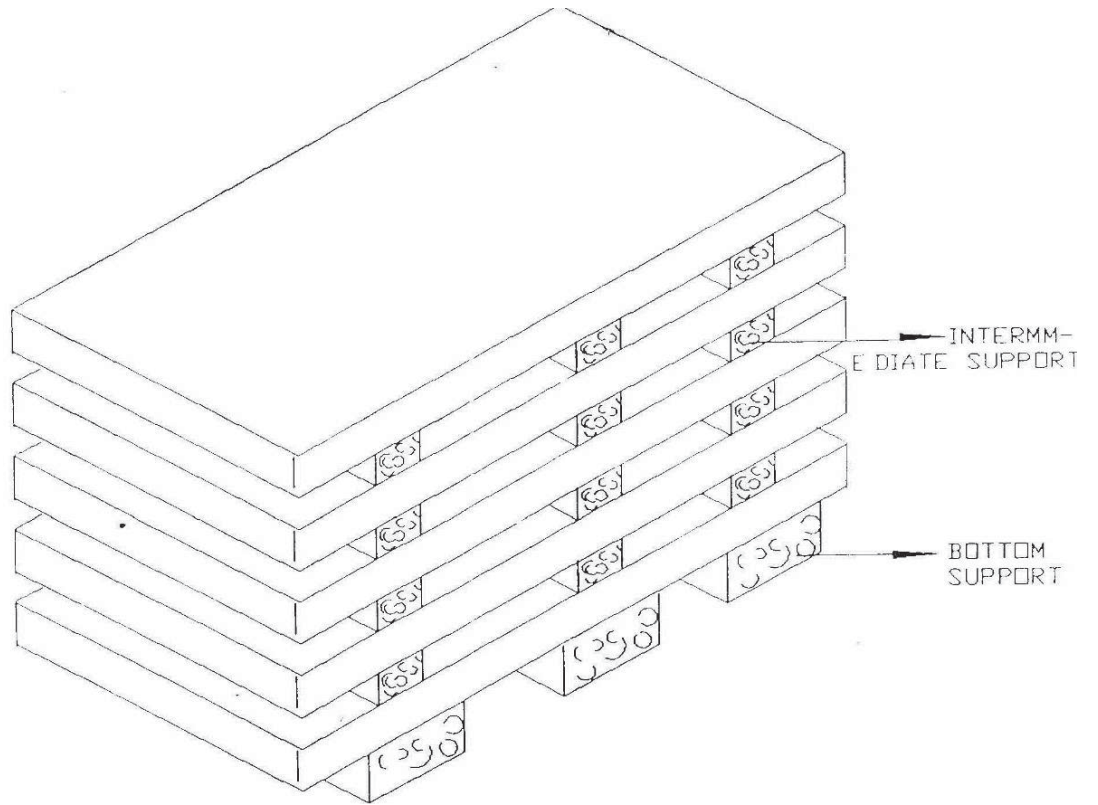

Figure – 1 – PLATE STACKING ARRANGEMENT

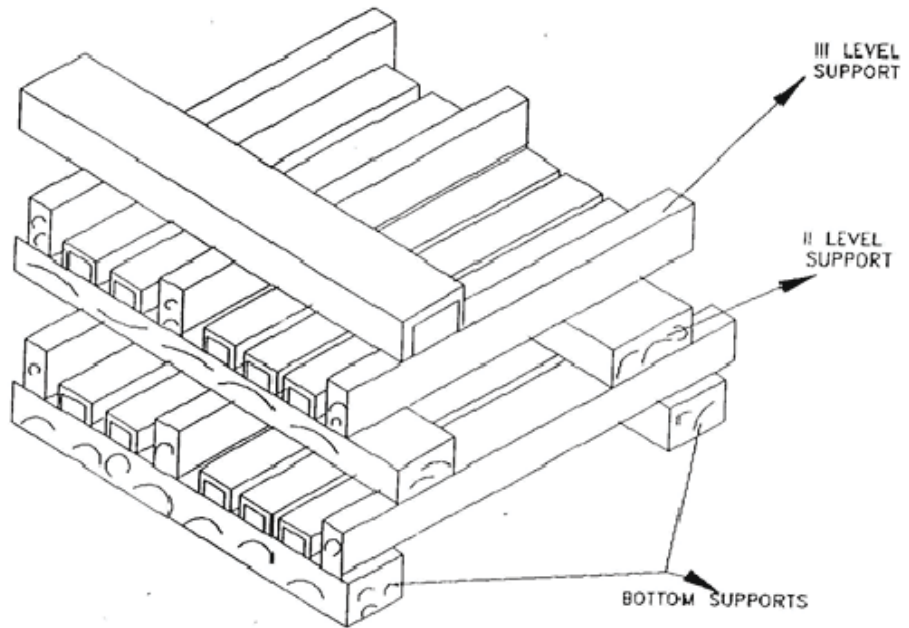

Figure – 2 – STRUCTURAL STEEL STACKING ARRANGEMENT

NTPC Limited

(A Government of India Enterprise)



TALCHER THERMAL POWER PROJECT STAGE - III (2x660MW)

PART - C

GENERAL TECHNICAL REQUIREMENTS

SECTION – VI

TECHNICAL SPECIFICATION

FOR

EPC PACKAGE

BIDDING DOCUMENT NO.: CS-4540-001A-2

(This document is meant for the exclusive purpose of bidding against this Package and shall not be transferred, reproduced or otherwise used for purposes other than that for which it is specifically issued).

CLAUSE NO.	GENERAL TECHNICAL REQUIREMENTS			
1.00.00	<p>INTRODUCTION</p> <p>This part covers technical requirements which will form an integral part of the Contract. The following provisions shall supplement all the detailed technical specifications and requirements brought out in Section-VI, the Technical Specification and the Technical Data Sheets.</p>			
2.00.00	<p>BRAND NAME</p> <p>Whenever a material or article is specified or described by the name of a particular brand, manufacturer or vendor, the specific item mentioned shall be understood to be indicative of the function and quality desired, and not restrictive; other manufacturer's products may be considered provided sufficient information is furnished to enable the Employer to determine that the products proposed are equivalent to those named.</p>			
3.00.00	<p>BASE OFFER & ALTERNATE PROPOSALS</p> <p>The Bidder's proposal shall be based upon the use of equipment and material complying fully with the requirements specified herein. It is recognized that the Contractor may have standardized on the use of certain components, materials, processes or procedures different than those specified herein. Alternate proposals offering similar equipment based on the manufacturer's standard practice will also be considered, provided the base offer is in line with technical specifications and such proposals meet the specified design standards and performance requirement and are acceptable to the Employer. Sufficient amount of information for justifying such proposals shall be furnished to Employer alongwith the bid to enable the Employer to determine the acceptability of these proposals.</p>			
4.00.00	<p>COMPLETENESS OF FACILITIES</p>			
4.01.00	<p>Bidders may note that this is a EPC Package contract. Each of the plant shall be engineered and designed in accordance with the specification requirement. All engineering and associated services are required to ensure a completely engineered plant shall be provided.</p>			
4.02.00	<p>All equipments furnished by the Contractor shall be complete in every respect, with all mountings, fittings, fixtures and standard accessories normally provided with such equipment and/or those needed for erection, completion and safe operation of the equipment and for the safety of the operating personnel, as required by applicable codes, though they may not have been specifically detailed in the respective specifications, unless included in the list of exclusions.</p> <p>All same standard components/ parts of same equipment provided, shall be interchangeable with one another.</p>			
<p>TALCHER THERMAL POWER PROJECT STAGE-III (2X660 MW) EPC PACKAGE</p>	<p>TECHNICAL SPECIFICATIONS SECTION VI, PART-C BID DOC. NO.:CS-4540-001A-2</p>	<p>GENERAL TECHNICAL REQUIREMENTS</p>	<p>PAGE 1 OF 114</p>	

CLAUSE NO.	GENERAL TECHNICAL REQUIREMENTS		
4.03.00	For the C&I systems, the Contractor shall be required to provide regular information about future upgrades and migration paths to the Employer.		
5.00.00	CODES & STANDARDS		
5.01.00	<p>In addition to the codes and standards specifically mentioned in the relevant technical specifications for the equipment / plant / system, all equipment parts, systems and works covered under this specification shall comply with all currently applicable statutory regulations and safety codes of the Republic of India as well as of the locality where they will be installed, including the following :</p> <ul style="list-style-type: none"> a) Indian Electricity Act b) Indian Electricity Rules c) Indian Explosives Act d) Indian Factories Act and State Factories Act e) Indian Boiler Regulations (IBR) f) Regulations of the Central Pollution Control Board, India g) Regulations of the Ministry of Environment & Forest (MoEF), Government of India h) Pollution Control Regulations of Department of Environment, Government of India i) State Pollution Control Board. (j) Rules for Electrical installation by Tariff Advisory Committee (TAC). (k) Building and other construction workers (Regulation of Employment and Conditions of services) Act, 1996 (l) Building and other construction workers (Regulation of Employment and Conditions of services) Central Rules, 1998 (m) Explosive Rules, 1983 (n) Petroleum Act, 1984 (o) Petroleum Rules, 1976, (p) Gas Cylinder Rules, 1981 		
TALCHER THERMAL POWER PROJECT STAGE-III (2X660 MW) EPC PACKAGE	TECHNICAL SPECIFICATIONS SECTION VI, PART-C BID DOC. NO.:CS-4540-001A-2	GENERAL TECHNICAL REQUIREMENTS	PAGE 2 OF 114

CLAUSE NO.	GENERAL TECHNICAL REQUIREMENTS			
5.02.00	<p>(q) Static and Mobile Pressure Vessels (Unified) Rules, 1981</p> <p>(r) Workmen's Compensation Act, 1923</p> <p>(s) Workmen's Compensation Rules, 1924</p> <p>(t) NTPC Safety Rules for Construction and Erection</p> <p>(u) NTPC Safety Policy</p> <p>(v) Any other statutory codes / standards / regulations, as may be applicable.</p> <p>Unless covered otherwise in the specifications, the latest editions (as applicable as on the date of bid opening), of the codes and standards given below shall also apply:</p> <p>a) Bureau of Indian standards (BIS)</p> <p>b) Japanese Industrial Standards (JIS)</p> <p>c) American National Standards Institute (ANSI)</p> <p>d) American Society of Testing and Materials (ASTM)</p> <p>e) American Society of Mechanical Engineers (ASME)</p> <p>f) American Petroleum Institute (API)</p> <p>g) Standards of the Hydraulic Institute, U.S.A.</p> <p>h) International Organization for Standardization (ISO)</p> <p>i) Tubular Exchanger Manufacturer's Association (TEMA)</p> <p>j) American Welding Society (AWS)</p> <p>k) National Electrical Manufacturers Association (NEMA)</p> <p>l) National Fire Protection Association (NFPA)</p> <p>m) International Electro-Technical Commission (IEC)/ European Norm (EN)</p> <p>n) Expansion Joint Manufacturers Association (EJMA)</p> <p>o) Heat Exchange Institute (HEI)</p> <p>p) IEEE standard</p>			
TALCHER THERMAL POWER PROJECT STAGE-III (2X660 MW) EPC PACKAGE	TECHNICAL SPECIFICATIONS SECTION VI, PART-C BID DOC. NO.:CS-4540-001A-2	GENERAL TECHNICAL REQUIREMENTS	PAGE 3 OF 114	

CLAUSE NO.	GENERAL TECHNICAL REQUIREMENTS		
<p>5.03.00</p> <p>5.04.00</p> <p>5.05.00</p> <p>5.06.00</p> <p>5.07.00</p> <p>5.08.00</p> <p>6.00.00</p> <p>6.01.00</p>	<p>q) JEC standard</p> <p>Other International/ National standards such as DIN, VDI, BS, GOST etc. shall also be accepted for only material codes and manufacturing standards, subject to the Employer's approval, for which the Bidder shall furnish, adequate information to justify that these standards are equivalent or superior to the standards mentioned above. In all such cases the Bidder shall furnish specifically the variations and deviations from the standards mentioned elsewhere in the specification together with the complete word to word translation of the standard that is normally not published in English.</p> <p>As regards highly standardized equipments such as Steam Turbine and Generator, National /International standards such as JIS, DIN, VDI, ISO, SEL, SEW, VDE, IEC & VGB shall also be considered as far as applicable for Design, Manufacturing and Testing of the respective equipment. However, for those of the above equipment not covered by these National / International standards, established and proven standards of manufacturers shall also be considered.</p> <p>In the event of any conflict between the codes and standards referred to in the above clauses and the requirement of this specification, the requirement of Technical Specification shall govern.</p> <p>Two (2) English language copies of all national and international codes and/or standards used in the design of the plant and equipment shall be provided by the Contractor to the Employer within two calendar months from the date of the Notification of Award.</p> <p>In case of any change in codes, standards & regulations between the date of bid opening and the date when vendors proceed with fabrication, the Employer shall have the option to incorporate the changed requirements or to retain the original standard. It shall be the responsibility of the Contractor to bring to the notice of the Employer such changes and advise Employer of the resulting effect.</p> <p>A detailed list of standards apart from those mentioned in the respective detailed specifications in other parts of Section-VI to which all equipment/systems/civil works should conform as indicated in this Part C and elsewhere in the specification.</p> <p>EQUIPMENT FUNCTIONAL GUARANTEE</p> <p>The functional guarantees of the equipment under the scope of the Contract is given in Section-VI Part - A & B of Technical Specifications. These guarantees shall supplement the general functional guarantee provisions covered under Defect liabilities Section-IV, General Conditions of Contract.</p>		
<p>TALCHER THERMAL POWER PROJECT STAGE-III (2X660 MW) EPC PACKAGE</p>	<p>TECHNICAL SPECIFICATIONS SECTION VI, PART-C BID DOC. NO.:CS-4540-001A-2</p>	<p>GENERAL TECHNICAL REQUIREMENTS</p>	<p>PAGE 4 OF 114</p>

CLAUSE NO.	GENERAL TECHNICAL REQUIREMENTS			
6.02.00	Liquidated damages for shortfall in meeting functional guarantee(s) during the performance and guarantee tests shall be assessed and recovered from the Contractor as specified elsewhere in this specification.			
7.00.00	DESIGN OF FACILITIES/ MAINTENANCE & AVAILABILITY CONSIDERATIONS			
7.01.00	<p>DESIGN OF FACILITIES</p> <p>All the design procedures, systems and components proposed shall have already been adequately developed and shall have demonstrated good reliability under similar conditions elsewhere.</p> <p>The Contractor shall be responsible for the selection and design of appropriate equipments to provide the best co-ordinated performance of the entire system. The basic requirements are detailed out in various clauses of the Technical Specifications. The design of various components, assemblies and subassemblies shall be done so that it facilitates easy field assembly and dismantling. All the rotating components shall be so selected that the natural frequency of the complete unit is not critical or close to the operating range of the unit.</p>			
7.02.00	<p>MAINTENANCE AND AVILABILITY CONSIDERATIONS</p> <p>Equipment/works offered shall be designed for high availability, low maintenance and ease of maintenance. The Bidder shall specifically state the design features incorporated to achieve high degree of reliability/ availability and ease of maintenance. The Bidder shall also furnish details of availability records in the reference plants stated in his experience list.</p> <p>Bidder shall state in his offer the various maintenance intervals, spare parts and man-hour requirement during such operation. The intervals for each type of maintenance namely inspection of the furnace, inspection of the entire hot gas path, turbine & equipments, inspection of the steam path and the minor and major overhauls shall be specified in terms of fired hours, clearly defining the spare parts and man-hour requirement for each stage.</p> <p>Lifting devices i.e. hoists and chain pulley jacks, etc. shall be provided by the contractor for handling of any equipment or any of its part having weight in excess of 500 Kgs during erection and maintenance activities.</p> <p>Lifting devices like lifting tackles, slings, etc. to be connected to hook of the hoist / crane shall be provided by the contractor for lifting the equipment and accessories covered under the specification.</p>			
TALCHER THERMAL POWER PROJECT STAGE-III (2X660 MW) EPC PACKAGE		TECHNICAL SPECIFICATIONS SECTION VI, PART-C BID DOC. NO.:CS-4540-001A-2	GENERAL TECHNICAL REQUIREMENTS	PAGE 5 OF 114

CLAUSE NO.	GENERAL TECHNICAL REQUIREMENTS			
8.00.00	DOCUMENTS, DATA AND DRAWINGS TO BE FURNISHED BY CONTRACTOR			
8.01.00	<p>Bidders may note that this is an EPC Package contract. Each of the plant and equipment shall be fully integrated, engineered and designed to perform in accordance with the technical specification. All engineering and technical services required to ensure a completely engineered plant shall be provided in respect of mechanical, electrical and power systems, control & instrumentation, civil & structural works as per the scope.</p> <p>Each main and auxiliary equipment/item of the plant including instruments shall be assigned a unique tag number. The assignment of tag numbers shall be in accordance with KKS system. In all drawings/documents/data sheet etc. KKS tag number of the equipment/item/instrument etc. shall be indicated.</p> <p>The Contractor shall furnish engineering data /drawings in accordance with the schedule of information as specified in Technical Data Sheets and Technical Specification.</p> <p>A comprehensive engineering and quality coordination procedure shall be finalized with the successful bidder covering salient features as described in this section of specifications.</p>			
8.02.00	The number of copies/prints/CD-ROMs/manuals to be furnished for various types of document is given in Annexure-VI to this Part-C, Section-VI of the Technical Specification.			
8.03.00	The documentation that shall be provided by the Contractor is indicated in the various sections of specification. This documentation shall include but not be limited to the following:			
8.03.01	<p>A) BASIC ENGINEERING DOCUMENTATION</p> <p>Prior to commencement of the detailed engineering work, the Contractor shall furnish a Plant Definition Manual within 12 weeks from the date of the Notification of Award. This manual shall contain the following as a minimum:</p> <ul style="list-style-type: none"> i) System description of all the mechanical, electrical, control & instrumentation & civil systems. ii) Technology scan for each system / sub-system & equipment. iii) Selection of appropriate technology / schemes for various systems/ subsystems including techno-economic studies between various options. 			
TALCHER THERMAL POWER PROJECT STAGE-III (2X660 MW) EPC PACKAGE		TECHNICAL SPECIFICATIONS SECTION VI, PART-C BID DOC. NO.:CS-4540-001A-2	GENERAL TECHNICAL REQUIREMENTS	PAGE 6 OF 114

CLAUSE NO.	GENERAL TECHNICAL REQUIREMENTS			
	<p>iv) Optimization studies including thermal cycle optimization.</p> <p>v) Sizing criteria of all the systems, sub-systems/ equipments/ structures/ equipment foundations alongwith all calculations justifying and identifying the sizing and the design margins.</p> <p>vi) Schemes and Process & Instrumentation diagrams for the various systems/ sub-system with functional write-ups.</p> <p>vii) Water Balance diagram.</p> <p>viii) Operation Philosophy and the control philosophy of the Main Plant and other plants.</p> <p>ix) General Layout plan of the power station incorporating all facilities in Bidder's as well as those in the Employer's scope. This drawing shall also be furnished in the form of CD-ROMs to the Employer for engineering of areas not included in bidder's scope.</p> <p>x) Basic layouts and cross sections of the main plant building (various floor elevations), boiler, fuel oil area, transformer yard, switchyard and other areas included in the scope of the bidder.</p> <p>xi) Documentation in respect of Quality Assurance System as listed out elsewhere in this specification.</p> <p>The successful bidder shall furnish within three (3) weeks from the date of Notification of Award, a list of contents of the Plant Definition Manual (PDMs) including techno-economic studies, which shall then be mutually discussed & finalised with the Employer.</p> <p>B) DETAILED ENGINEERING DOCUMENTS</p> <p>i) General layout plan of the station.</p> <p>ii) Layouts, general arrangements, elevations and cross-sections drawings for all the equipment and facilities of the plant.</p> <p>iii) Flow diagram, Process and Instrumentation diagrams along with write up and system description.</p> <p>iv) Start-up curves for boiler and both turbines and boiler combined together as a unit for various start-ups, viz. Cold, Warm and Hot start up.</p> <p>v) Piping isometric, composite layout and fabrication drawings.</p>			
<p>TALCHER THERMAL POWER PROJECT STAGE-III (2X660 MW) EPC PACKAGE</p>	<p>TECHNICAL SPECIFICATIONS SECTION VI, PART-C BID DOC. NO.:CS-4540-001A-2</p>	<p>GENERAL TECHNICAL REQUIREMENTS</p>	<p>PAGE 7 OF 114</p>	

CLAUSE NO.	GENERAL TECHNICAL REQUIREMENTS		
	<ul style="list-style-type: none"> vi) Piping engineering diagrams, pipe and fittings schedules, valve schedules, hanger and support schedules, insulation schedules. vii) Technical data sheets for all bought out and manufactured items. Contractor shall use the Employer's specifications as a base for placement of orders on their sub vendors. viii) Detailed design calculations for components, system, piping etc., wherever applicable including sizing calculations for all auxiliaries like Mills, Fans, BFPs, CEPs, Heaters/ Deaerators, Air cooled Condensers, Vacuum pumps etc. ix) Boiler pressure part schedule and sizing calculations. Boiler performance data and boiler design dossier. x) Transient, hydraulic and thermal stress analysis of piping and system wherever applicable & input and output data alongwith stress analysis isometrics showing nodes. xi) Thermal cycle information (heat balance diagrams, boiler performance calculations, condenser and heat exchanger thermal calculations etc.). xii) Characteristic Curves/ Performance Correction Curves. Hydraulic & Mechanical design calculations for condensers & heaters. xiii) Comprehensive list of all Terminal Points which interface with Employer's facilities, giving details of location, terminal pressure, temperature, fluid handled & end connection details, forces, moments etc. xiv) Power supply single line diagram, block logics, control schematics, electrical schematics, etc. xv) Protection system diagrams and relay settings. xvi) Cables schedules and interconnection diagrams. xvii) Cable routing plan. xviii) Instrument schedule, measuring point list, I/O list, Interconnection & wiring diagram, functional write-ups, installation drawings for field mounted instruments, logic diagrams, control schematics, wiring and tubing diagrams of panels and enclosures etc. Drawings for open loop and close loop controls (both hardware and software). Motor list and valve schedule including type of actuator etc. 		
<p style="text-align: center;">TALCHER THERMAL POWER PROJECT STAGE-III (2X660 MW) EPC PACKAGE</p>	<p style="text-align: center;">TECHNICAL SPECIFICATIONS SECTION VI, PART-C BID DOC. NO.:CS-4540-001A-2</p>	<p style="text-align: center;">GENERAL TECHNICAL REQUIREMENTS</p>	<p style="text-align: center;">PAGE 8 OF 114</p>

CLAUSE NO.	GENERAL TECHNICAL REQUIREMENTS			
8.03.02	<p>xix) Alarm and annunciation/ Sequence of Event (SOE) list and alarms & trip set points.</p> <p>xx) Sequence and protection interlock schemes.</p> <p>xxi) Type test reports, insulation co-ordination study report and power system stability study report.</p> <p>xxii) Control system configuration diagrams and card circuit diagrams and maintenance details.</p> <p>xxiii) Detailed DDCMIS system manuals.</p> <p>xxiv) Detailed flow chart for digital control system.</p> <p>xv) Mimic diagram layout, Assignment for other application engg.</p> <p>xxvi) Civil and Structural works drawings and documents for all structures, facilities, architectural works, foundations underground and overground works and super-structural works as included in the scope of the bidder civil calculation sheets including structural analysis and design alongwith output results.</p> <p>xxvii) Underground facilities, levelling, sanitary, land scaping drawings.</p> <p>xxviii) Geotechnical investigation and site survey reports (if and as applicable).</p> <p>xxix) Model study reports wherever applicable.</p> <p>xxx) Functional & guarantee test procedures and test reports.</p> <p>xxxi) Documentation in respect of Quality Assurance System, and Documentation in respect of Commissioning, as listed out elsewhere in this specification.</p> <p>The Contractor's while submitting the above documents/ drawings for approval/ reference as the case may be, shall mark on each copy of submission the reference letter alongwith the date vide which the submissions are made.</p> <p>INSTRUCTION MANUALS</p> <p>The Contractor shall submit to the Employer, draft Instruction Manuals for all the equipments covered under the Contract by the end of one year from the date of his acceptance of the Letter of Award. The Instruction manuals shall contain full details required for erection, commissioning, operation and maintenance of each</p>			
<p>TALCHER THERMAL POWER PROJECT STAGE-III (2X660 MW) EPC PACKAGE</p>	<p>TECHNICAL SPECIFICATIONS SECTION VI, PART-C BID DOC. NO.:CS-4540-001A-2</p>	<p>GENERAL TECHNICAL REQUIREMENTS</p>	<p>PAGE 9 OF 114</p>	

CLAUSE NO.	GENERAL TECHNICAL REQUIREMENTS			
	<p>equipment. The manual shall be specifically compiled for this project. After finalisation and approval of the Employer the Instruction Manuals shall be submitted as indicated in Annexure-IV. The Contract shall not be considered to be completed for purposes of taking over until the final Instructions manuals have been supplied to the Employer. The Instruction Manuals shall comprise of the following.</p> <p>A) ERECTION MANUALS</p> <p>The erection manuals shall be submitted at least three (3) months prior to the commencement of erection activities of a particular equipment/system. The erection manual should contain the following as a minimum.</p> <ol style="list-style-type: none"> a) Erection strategy. b) Sequence of erection. c) Erection instructions. d) Critical checks and permissible deviation/tolerances. e) List of tools, tackles, heavy equipments like cranes, dozers, etc. f) Bill of Materials g) Procedure for erection and General Safety procedures to followed during erection/installation. h) Procedure for initial checking after erection. i) Procedure for testing and acceptance norms. j) Procedure / Check list for pre-commissioning activities. k) Procedure / Check list for commissioning of the system. l) Safety precautions to be followed in electrical supply distribution during erection. <p>B) OPERATION & MAINTENANCE MANUALS</p> <ol style="list-style-type: none"> a) The manual shall be a two rim PVC bound stiff sided binder able to withstand constant usage or where a thicker type is required it shall have locking steel pins, the size of the manual shall not be larger than international size A3. The cover shall be printed with the Project 			
<p>TALCHER THERMAL POWER PROJECT STAGE-III (2X660 MW) EPC PACKAGE</p>	<p>TECHNICAL SPECIFICATIONS SECTION VI, PART-C BID DOC. NO.:CS-4540-001A-2</p>	<p>GENERAL TECHNICAL REQUIREMENTS</p>	<p>PAGE 10 OF 114</p>	

CLAUSE NO.	GENERAL TECHNICAL REQUIREMENTS			
	<p>Name, Services covered and Volume / Book number Each section of the manual shall be divided by a stiff divider of the same size as the holder. The dividers shall clearly state the section number and title. All written instructions within the manual not provided by the manufacturers shall be typewritten with a margin on the left hand side.</p> <p>b) The arrangement and contents of O & M manuals shall be as follows:</p> <p>1) <u>Chapter 1 - Plant Description:</u> To contain the following sections specific to the equipment/system supplied</p> <p>(a) Description of operating principle of equipment / system with schematic drawing / layouts.</p> <p>(b) Functional description of associated accessories / controls. Control interlock protection write up.</p> <p>(c) Integrated operation of the equipment alongwith the intended system. (This to be given by the supplier of the Main equipment by taking into account the operating instruction given by the associated suppliers).</p> <p>(d) Exploded view of the main equipment, associated accessories and auxiliaries with description. Schematic drawing of the equipment alongwith its accessories and auxiliaries.</p> <p>(e) Design data against which the plant performance will be compared.</p> <p>(f) Master list of equipments, Technical specification of the equipment/ system and approved data sheets.</p> <p>(g) Identification system adopted for the various components, (it will be of a simple process linked tagging system).</p> <p>(h) Master list of drawings (as built drawing - Drawings to be enclosed in a separate volume).</p> <p>2) <u>Chapter 2.0 - Plant Operation:</u> To contain the following sections specific to the equipment supplied</p> <p>(a) Protection logics provided for the equipment alongwith brief philosophy behind the logic, Drawings etc.</p> <p>(b) Limiting values of all protection settings.</p> <p>(c) Various settings of annunciation/interlocks provided.</p>			
<p>TALCHER THERMAL POWER PROJECT STAGE-III (2X660 MW) EPC PACKAGE</p>	<p>TECHNICAL SPECIFICATIONS SECTION VI, PART-C BID DOC. NO.:CS-4540-001A-2</p>	<p>GENERAL TECHNICAL REQUIREMENTS</p>	<p>PAGE 11 OF 114</p>	

CLAUSE NO.	GENERAL TECHNICAL REQUIREMENTS			
	<p>(d) Startup and shut down procedure for equipment alongwith the associated systems in step mode.</p> <p>(e) Do's and Don'ts related to operation of the equipment.</p> <p>(f) Safety precautions to be taken during normal operation. Emergency instruction on total power failure condition/lubrication failure/any other conditions.</p> <p>(g) Parameters to be monitored with normal value and limiting values.</p> <p>(h) Equipment isolating procedures.</p> <p>(i) Trouble shooting with causes and remedial measures.</p> <p>(j) Routine testing procedure to ascertain healthiness of the safety devices alongwith schedule of testing.</p> <p>(k) Routine Operational Checks, Recommended Logs and Records</p> <p>(l) Change over schedule if more than one auxiliary for the same purpose is given.</p> <p>(m) Preservation procedure on long shut down.</p> <p>(n) System/plant commissioning procedure.</p> <p>3) <u>Chapter 3.0 - Plant Maintenance</u>- To contain the following sections specific to the equipment supplied.</p> <p>(a) Exploded view of each of the equipments. Drawings alongwith bill of materials including name, code no. & population.</p> <p>(b) Exploded view of the spare parts and critical components with dimensional drawings (In case of Electronic cards, the circuit diagram to be given) and spare parts catalogue for each equipment.</p> <p>(c) List of Special T/ P required for Overhauling /Trouble shooting including special testing equipment required for calibration etc.</p> <p>(d) Stepwise dismantling and assembly procedure clearly specifying the tools to be used, checks to be made, records to be maintained etc. Clearance to be maintained etc.</p>			
<p>TALCHER THERMAL POWER PROJECT STAGE-III (2X660 MW) EPC PACKAGE</p>	<p>TECHNICAL SPECIFICATIONS SECTION VI, PART-C BID DOC. NO.:CS-4540-001A-2</p>	<p>GENERAL TECHNICAL REQUIREMENTS</p>	<p>PAGE 12 OF 114</p>	

CLAUSE NO.	GENERAL TECHNICAL REQUIREMENTS		
8.03.03	<p>(e) Preventive Maintenance schedules linked with running hours/calendar period alongwith checks to be carried out.</p> <p>(f) Overhauling schedules linked with running hours/calendar period alongwith checks to be done.</p> <p>(g) Long term maintenance schedules</p> <p>(h) Consumables list alongwith the estimated quantity required during normal running and during maintenance like Preventive Maintenance and Overhauling.</p> <p>(i) List of lubricants with their Indian equivalent, Lubrication Schedule including charts showing lubrication checking, testing and replacement procedure to be carried daily, weekly, monthly & at longer intervals to ensure trouble free operation and quantity required for complete replacement.</p> <p>(j) Tolerance for fitment of various components.</p> <p>(k) Details of sub vendors with their part no. in case of bought out items.</p> <p>(l) List of spare parts with their Part No, total population, life expediency & their interchangeability with already supplied spares to NTPC.</p> <p>(m) List of mandatory and recommended spare list along with manufacturing drawings, material specification & quality plan for fast moving consumable spares.</p> <p>(n) Lead time required for ordering of spares from the equipment supplier, instructions for storage and preservation of spares.</p> <p>(o) General information on the equipment such as modification carried out in the equipment from its inception, equipment population in the country / foreign country and list of utilities where similar equipments have been supplied.</p> <p>After finalization and approval of the Employer, the O & M Manuals shall be submitted as indicated in Annexure-VI. The Contract shall not be considered to be completed for purposes of taking over until the final Instructions manuals (both erection and O & M manuals have been supplied to the Employer.</p> <p>If after the commissioning and initial operation of the plant, the instruction manuals (Erection and /or O &M manuals) require modifications/additions/ changes, the same shall be incorporated and the updated final instruction manuals shall be submitted by</p>		
TALCHER THERMAL POWER PROJECT STAGE-III (2X660 MW) EPC PACKAGE	TECHNICAL SPECIFICATIONS SECTION VI, PART-C BID DOC. NO.:CS-4540-001A-2	GENERAL TECHNICAL REQUIREMENTS	PAGE 13 OF 114

CLAUSE NO.	GENERAL TECHNICAL REQUIREMENTS			
	<p>the Contractor to the Employer for records and number of copies shall be as mentioned in Annexure-VI.</p>			
8.03.03	PLANT HANDBOOK AND PROJECT COMPLETION REPORT			
8.03.03.01	PLANT HANDBOOK			
	<p>The Contractor shall submit to the Employer a preliminary plant hand book preferably in A-4 size sheets which shall contain the design and performance data of various plants, equipments and systems covering the complete project including</p> <ul style="list-style-type: none"> i) Design and performance data. ii) Process & Instrumentation diagrams. iii) Single line diagrams. iv) Sequence & Protection Interlock Schemes. v) Alarm and trip values. vi) Performance Curves. vii) General layout plan and layout of main plant building and auxiliary buildings viii) Important Do's & Don't's <p>The plant handbook shall be submitted within twelve (12) months from the date of award of contract. After the incorporation of Employer's comments, the final plant handbook complete in all respects shall be submitted three (3) months before start-up and commissioning activities.</p>			
8.03.03.02	PROJECT COMPLETION REPORT			
	<p>The Contractor shall submit a Project Completion Report at the time of handing over the plant.</p>			
8.03.04	DRAWINGS			
	<ul style="list-style-type: none"> a) i) All the plant layouts shall be made in computerized 3D modelling system. The Employer reserves the right to review the 3D model at different stages during the progress of engineering. The layout drawings submitted for Employer's review shall be fully dimensioned and extracted from 3D model after interference check. ii) All documents submitted by the Contractor for Employer's review shall be in electronic form (soft copies) along with the desired number 			
<p>TALCHER THERMAL POWER PROJECT STAGE-III (2X660 MW) EPC PACKAGE</p>	<p>TECHNICAL SPECIFICATIONS SECTION VI, PART-C BID DOC. NO.:CS-4540-001A-2</p>	<p>GENERAL TECHNICAL REQUIREMENTS</p>	<p>PAGE 14 OF 114</p>	

CLAUSE NO.	GENERAL TECHNICAL REQUIREMENTS			
	<p>of hard copies as per Annexure-VI of Part-C. The soft copies shall be uploaded by the vendors in C-folders, a Web-based system of NTPC ERP, for which a username and password will be allotted to the new vendor by NTPC.</p> <p>Similarly, the vendor can download the drawings/documents, approved/ commented by NTPC, through above site.</p> <p>The soft copies of identified drawings/documents shall be in pdf format, whereas the attachments/reply to the submitted document(s) can be in .doc, .xls, .pdf, .dwg or .std formats.</p> <p>iii) Final copies of the approved drawings along with requisite number of hard copies shall be submitted as per Annexure-VI of Part-C.</p> <p>iv) Contractor shall prepare the model of all the facilities located within plant boundary covering facilities in Main Plant Block area and Balance of plant (BOP) area in an integrated & intelligent 3D software solution. Main Plant Block area shall include Transformer Yard, TG building (including all facilities), Boiler area, ESP area, chimney area, FGD area and any other facility located in main plant block. BOP area shall include all facilities pertaining to AHP, CHP, LHP, GHP, DM PT plant, pipe & cable racks and any other facility located within plant boundary.</p> <p>All piping layouts, equipment layouts, floor plans, ducting layout (Air/flue gas, A/C, Ventilation etc.), General Arrangement drawings and RCC layout of major buildings and structural arrangement drawings shall necessarily be extracted from the aforesaid 3D model and submitted for employer's review along with the 3D review model to enable NTPC to review and approve these drawings.</p> <p>Contractor shall prepare and provide 3D design review model (network ready, which shall include visual interference check, walk-through animation, video simulation for major equipment placement and removal, visual effect, photo realism etc.), which is extracted from intelligent 3D model and shall make a presentation of the same every 3 months from LOA to enable NTPC to review the progress of engineering or as & when required by employer.</p> <p>The complete 3D data (editable model) which shall be utilised for all future detailed engineering related to maintenance, operation, R&M, efficiency improvement of the project etc. Complete 3D model along with as built GADs, layout, isometrics, reports extracted and 3D models for all disciplines , with any other document generated from 3D model and naming conventions with as-built updates along with complete reference databases, component catalogues for all the size range shall be handed over to owner. Apart from the 3D Model, all</p>			
<p>TALCHER THERMAL POWER PROJECT STAGE-III (2X660 MW) EPC PACKAGE</p>	<p>TECHNICAL SPECIFICATIONS SECTION VI, PART-C BID DOC. NO.:CS-4540-001A-2</p>	<p>GENERAL TECHNICAL REQUIREMENTS</p>	<p>PAGE 15 OF 114</p>	

CLAUSE NO.	GENERAL TECHNICAL REQUIREMENTS			
	<p>drawings like GADs, Isometrics etc. extracted from the model shall also be submitted by the Contractor in Electronic form. 3D model along with complete Project databases shall be submitted at each model review stage and as final as-built. The contractor shall also submit all the configuration files, customization files, templates and all referenced databases.</p> <p>All input files of software used for design of Equipments / Piping like CAESAR2 files, input files for Pressure vessel design, datasheets etc., shall be handed over to NTPC as per NTPC specifications for handover of Engineering Information.</p> <p>Further, two Licenses of the used 3D Modelling Software (One for Engineering View and One for Site View) shall be provided along with compatible Hardware for possible review and study of the Model Files being submitted by the Bidder Time to time.</p> <p>Handover Plan: There shall be continuous handover of documents and data at various stages of the project including rules and trigger points for handover of data to NTPC shall be at 30%, 60% and 90 % of 3D model stage.</p> <p>Database backup shall be taken every month and handed over to NTPC.</p> <p>b) All documents/text information shall be in latest version of MS Office/MS Excel/PDF format as applicable.</p> <p>c) All drawings submitted by the Contractor including those submitted at the time of bid shall be in sufficient detail indicating the type, size, arrangement, weight of each component for packing and shipment, the external connection, fixing arrangement required, the dimensions required for installation and interconnections with other equipments and materials, clearance and spaces required between various portions of equipment and any other information specifically requested in the drawing schedules.</p> <p>d) Each drawing submitted by the Contractor (including those of sub-vendors) shall bear a title block at the right hand bottom corner with clear mention of the name of the Employer, the system designation, the specifications title, the specification number, the name of the Project, drawing number and revisions. If standard catalogue pages are submitted the applicable items shall be indicated therein. All titles, notings, markings and writings on the drawing shall be in English. All the dimensions should be in metric units.</p> <p>e) The drawings submitted by the Contractor (or their subvendors) shall bear Employer's drawing number in addition to contractor's (their sub-vendor's)</p>			
<p>TALCHER THERMAL POWER PROJECT STAGE-III (2X660 MW) EPC PACKAGE</p>	<p>TECHNICAL SPECIFICATIONS SECTION VI, PART-C BID DOC. NO.:CS-4540-001A-2</p>	<p>GENERAL TECHNICAL REQUIREMENTS</p>	<p>PAGE 16 OF 114</p>	

CLAUSE NO.	GENERAL TECHNICAL REQUIREMENTS			
	<p>own drawing number. Employer's drawing numbering system shall be made available to the successful bidder to enable him to assign Employer's drawing numbers to the drawings to be submitted by him during the course of execution of the Contract.</p> <p>Similarly, all the drawings/ documents submitted by the Contractor during detailed engineering stage shall be marked "FOR APPROVAL" or "FOR INFORMATION" prior to submission in line with suggestive MDL.</p> <p>Further, space shall be identified on each drawing for Approval stamp and electronic signature.</p> <p>f) The furnishing of detailed engineering data and drawings by the Contractor shall be in accordance with the time schedule for the project. The review of these documents/ data/ drawings by the Employer will cover only general conformance of the data/ drawings/ documents to the specifications and contract, interfaces with the equipments provided by others and external connections & dimensions which might affect plant layout. The review by the Employer should not be construed to be a thorough review of all dimensions, quantities and details of the equipments, materials, any devices or items indicated or the accuracy of the information submitted. The review and/ or approval by the Employer/ Project Manager shall not relieve the Contractor of any of his responsibilities and liabilities under this contract.</p> <p>g) After the approval of the drawings, further work by the Contractor shall be in strict accordance with these approved drawings and no deviation shall be permitted without the written approval of the Employer.</p> <p>h) All manufacturing, fabrication and execution of work in connection with the equipment / system, prior to the approval of the drawings, shall be at the Contractor's risk. The Contractor is expected not to make any changes in the design of the equipment /system, once they are approved by the Employer. However, if some changes are necessitated in the design of the equipment/system at a later date, the Contractor may do so, but such changes shall promptly be brought to the notice of the Employer indicating the reasons for the change and get the revised drawing approved again in strict conformance to the provisions of the Technical Specification.</p> <p>i) Drawings shall include all installations and detailed piping layout drawings. Layout drawings for all piping of 65 mm and larger diameter shall be submitted for review/ approval of Employer prior to erection. Small diameter pipes shall however be routed as per site conditions in consultation with site authority/ representative of Employer based on requirements of such piping indicated in approved/ finalised Flow Scheme/ Process & Instrumentation Diagrams and/or the requirements cropping up for draining & venting of larger diameter piping or otherwise after their erection as per actual physical condition for the entire scope of work of this package.</p>			
<p>TALCHER THERMAL POWER PROJECT STAGE-III (2X660 MW) EPC PACKAGE</p>	<p>TECHNICAL SPECIFICATIONS SECTION VI, PART-C BID DOC. NO.:CS-4540-001A-2</p>	<p>GENERAL TECHNICAL REQUIREMENTS</p>	<p>PAGE 17 OF 114</p>	

CLAUSE NO.	GENERAL TECHNICAL REQUIREMENTS			
	<p>Assessing & anticipating the requirement and supply of all piping and equipment shall be done by the contractor well in advance so as not to hinder the progress of piping & equipment erection, subsequent system charging and its effective draining & venting arrangement as per site suitability.</p> <p>j) As Built Drawings</p> <p>After final acceptance of individual equipment / system by the Employer, the Contractor will update all original drawings and documents for the equipment / system to “as built” conditions and submit no. of copies as per Annexure VI.</p> <p>k) Drawings must be checked by the Contractor in terms of its completeness, data adequacy and relevance with respect to Engineering schedule prior to submission to the Employer. In case drawings are found to be submitted without proper checking by the Contractor, the same shall not be reviewed and returned to the Contractor for re-submission. The contractor shall make a visit to site to see the existing facilities and understand the layout completely and collect all necessary data/ drawings at site which are needed as an input to the engineering. The contractor shall do the complete engineering including interfacing and integration of all his equipment, systems & facilities within his scope of work as well as interface engineering & integration of systems, facilities, equipment & works under Employer's scope and submit all necessary drawings/ documents for the same.</p> <p>l) The Contractor shall submit adequate prints of drawing / data / document for Employer's review and approval. The Employer shall review the drawings and return soft copy to the Contractor authorizing either to proceed with manufacture or fabrication or marked to show changes desired. When changes are required, drawings shall be re-submitted promptly, with revisions clearly marked, for final review. Any delays arising out of the failure of the Contractor to submit/rectify and resubmit in time shall not be accepted as a reason for delay in the contract schedule.</p> <p>m) All engineering data submitted by the Contractor after final process including review and approval by the Project Manager/ Employer shall form part of the contract documents and the entire works covered under these specification shall be performed in strict conformity with technical specifications unless otherwise expressly requested by the Project Manager in writing.</p>			
<p>TALCHER THERMAL POWER PROJECT STAGE-III (2X660 MW) EPC PACKAGE</p>	<p>TECHNICAL SPECIFICATIONS SECTION VI, PART-C BID DOC. NO.:CS-4540-001A-2</p>	<p>GENERAL TECHNICAL REQUIREMENTS</p>	<p>PAGE 18 OF 114</p>	

CLAUSE NO.	GENERAL TECHNICAL REQUIREMENTS			
8.03.05	e-Learning Package:			
	e-learning packages shall be supplied for the equipment / system for the following Steam Turbine Generator & auxiliaries and Steam Generator & auxiliaries along with associated electrical and C&I system.			
8.03.05.01	Steam Turbine Generator & Auxiliaries			
	Steam Turbine including stop valves, control valves, overload valves and cross over piping. Steam Turbine Auxiliary Systems including Quick Closing and Ordinary NRVs, Turbine gland sealing system, Lubricating oil system and its purification system, Centralized oil storage and its purification system, Control fluid and its purification system, governing and protection system, exhaust hood spray cooling system, drainage and vent system, turbine preservation system, HP/LP Bypass system.			
	Generator and Auxiliary System including Generator, complete hydrogen cooling, carbon dioxide and nitrogen gas systems as applicable, complete seal oil system, complete water cooling system where applicable and complete excitation system.			
	Condensing Plant including Condenser, Condenser air evacuation system and Condenser on load tube cleaning system as applicable etc.			
	Drip Pump along with all accessories as applicable, Condensate Extraction Pumps along with all accessories, Deaerator level Control Station, Feed Water Heating Plant including Drain Cooler, low pressure heaters, deaerator and feed storage tank, high pressure heaters and associated accessories, Boiler Feed Pumps along with all accessories, Drive Turbine for Boiler Feed Pump along with all accessories, Feed regulating station, Make up system to Condenser, Gland Steam Condenser Recirculation System, Turbine Hall EOT Cranes and EOT Crane for Boiler Feed Pump as applicable.			
8.03.05.02	Steam Generator & Auxiliaries			
	Furnace/evaporator, separator & drain collection vessel, superheater, reheater, economiser, startup recirculation & drain system, desuperheating spray system, safety valves, soot blowing system, draft plant including FD & ID fans, PA fan, air preheaters, SCAPH, coal preparation and firing system including raw coal feeder and pulverisers, coal burners, fuel oil system and oil burners, Electrostatic precipitator, NOx control system and Flue gas desulphurisation system, Aux. PRDS system.			
8.03.05.03	These packages shall be installed on the Learning Management Server (LMS) of Power Management Institute (PMI), NTPC located at Noida. The Engineer- In-Charge (EIC) for the e-learning modules shall be from PMI.			
	<ol style="list-style-type: none"> The objective of the e-Learning package consisting of courses for erection, commissioning, operation and maintenance of equipment / system as specified 			
TALCHER THERMAL POWER PROJECT STAGE-III (2X660 MW) EPC PACKAGE	TECHNICAL SPECIFICATIONS SECTION VI, PART-C BID DOC. NO.:CS-4540-001A-2	GENERAL TECHNICAL REQUIREMENTS	PAGE 19 OF 114	

CLAUSE NO.	GENERAL TECHNICAL REQUIREMENTS			
	<p>above is to facilitate the employees to have first hand information / requirement with respect to above activities for the supplied equipment / system .</p> <p>2. The bidder shall submit e-learning courses each for erection, commissioning, operation and maintenance of each of the equipment / system supplied as above.</p> <p>a. The erection course(s) should include instructions on pre-checks, prerequisites, erection strategy, erection procedure etc.</p> <p>b. The commissioning course(s) should include instructions on pre-commissioning, commissioning, initial operation etc.</p> <p>c. The operation course(s) should include instructions on the permissive, interlocks, physical check-ups, start-up, shutdown and protections etc.</p> <p>d. The maintenance course(s) should include instructions on predictive, preventive, breakdown and overhauling.</p> <p>Depth of coverage of above courses shall be as specified for “Instruction Manuals” in above clauses. A literature on caution / safety while handling equipment / system for the above modules shall follow the description of the said equipment /system.</p> <p>3. The e-Learning packages on equipment / system shall be installed by the vendor and shall be successfully test run in the presence of EIC or representative before acceptance by NTPC. The vendor will also give the master copy in form of Flash Drive/CD/DVD. The respective module for erection & commissioning shall be delivered and successfully test run at least three months before the scheduled start of the corresponding activity at site.</p> <p>The respective module for operation & maintenance shall be delivered and successfully test run at least three months before scheduled first synchronization of first unit.</p> <p>4. e-Learning course broad requirements:</p> <p>a. The courses shall be web based and mobile based Application type. It shall run on all possible versions of web browser like Internet Explorer, Google Chrome, Firefox etc. on Laptop/Desktop and shall be Smartphone/Tablet/Mobile responsive. The Mobile responsive courses shall run on Android, Windows Mobile, Blackberry, iOS etc.</p> <p>b. The courses shall support liquid/fluid page layout so that the entire screen gets adjusted to PC, Laptop, Smartphone/Mobile, Tablet and any other display devices.</p> <p>c. Course content text shall be in English language and be associated with a voiceover in English language with Indian accent.</p>			
<p>TALCHER THERMAL POWER PROJECT STAGE-III (2X660 MW) EPC PACKAGE</p>	<p>TECHNICAL SPECIFICATIONS SECTION VI, PART-C BID DOC. NO.:CS-4540-001A-2</p>	<p>GENERAL TECHNICAL REQUIREMENTS</p>	<p>PAGE 20 OF 114</p>	

CLAUSE NO.	GENERAL TECHNICAL REQUIREMENTS			
	<p>d. Courses shall be SCORM (Sharable Content Object Reference Model) compliant, version 1.2 which is compatible with LMS at PMI.</p> <p>e. Each course shall have every physical and functional detail of the equipment / system supplied.</p> <p>f. Each of the e-Learning course shall be based on multiple web pages and mobile pages with multiple modules.</p> <p>g. There shall be option for self-assessment test after every course. In case the user doesn't opt for self-assessment test the user shall be able to go to the next course. There shall be no restriction in no. of times for repeating the assessments. All correct answers along with the answers marked by the users shall be displayed at the end of test/quiz.</p> <p>h. If Java and Flash, as applicable are not available in the system to run the package, then there shall be a prompt message for updation of the same.</p> <p>i. Each course shall have a self-running interactive content with navigation buttons containing forward, backward, pause, bookmark and menu options in the course window.</p> <p>j. The course shall contain chapter titled 'Introduction/overview' that explains the purpose of the course.</p> <p>k. The course content shall contain descriptive text shall be factual, specific, terse, clearly worded, and simply illustrative, so that the user can understand it.</p> <p>l. The system shall provide the user with the ability to select the information with a Cursor.</p> <p>m. The course menu should contain table of content linked to concerned pages. The user shall be given the capability to access all of the functions available on the system through a menu system. This shall consist of active buttons, which shall control a hierarchy of pull down/pop-up menus. Menu shall appear quickly and exist only while a selection is being made. The user shall be given the capability to position the cursor or pointer on the menu item and use pointer device such as mouse to activate the function.</p> <p>n. Every course shall contain the 3D design/drawing/exploded view/360° turn around view of the equipment/system, textual description of the equipment/system and its functionality with video (as applicable), animation and audio.</p> <p>o. The users shall be able to control audio sound level associated with the courses.</p> <p>p. Drawings / text in the courses shall be scalable (Zoom In/ Out).</p> <p>q. The user shall have the capability to record a bookmark to mark displayed information for later recall, whenever he accesses the same course next time.</p>			
<p>TALCHER THERMAL POWER PROJECT STAGE-III (2X660 MW) EPC PACKAGE</p>	<p>TECHNICAL SPECIFICATIONS SECTION VI, PART-C BID DOC. NO.:CS-4540-001A-2</p>	<p>GENERAL TECHNICAL REQUIREMENTS</p>	<p>PAGE 21 OF 114</p>	

CLAUSE NO.	GENERAL TECHNICAL REQUIREMENTS			
<p>8.04.00</p> <p>8.05.00</p> <p>8.05.01</p>	<p>Notes:</p> <ol style="list-style-type: none"> 1. e-learning Package of an equipment / system shall include e-learning courses for each of erection, commissioning, operation and maintenance of that equipment / system. 2. e-learning courses on erection, commissioning, operation and maintenance of an equipment / system shall include e-learning lessons/chapters/modules (as required) for erection, commissioning, operation and maintenance respectively of that equipment / system. 3. The vendor shall get the approval of one sample course from EIC before proceeding for further courses. <p>Provision for Fail Safe operation of vital Equipments</p> <p>All the Plant and equipments / Systems supplied under the contract shall be designed following “Fail Safe” concept. In case of failure of Power supply like Electric power, Hydraulic pressure, Pneumatic pressure, Vacuum etc. the system should be designed in such a way that the equipment/Valves/dampers etc. shall always move/remains (as applicable) to safest position as per system requirement to ensure safety of Man and Machinery.</p> <p>Engineering Co-ordination Procedure</p> <p>The following principal coordinators will be identified by respective organizations at time of award of contract:</p> <p>NTPC Engineering Coordinator (NTPC EC):</p> <p>Name : _____</p> <p>Designation : _____</p> <p>Address : _____</p> <p>a) Postal : _____</p> <p>b) Telegraphic / e-Mail : _____</p> <p>c) FAX : _____ TELEPHONE : _____</p> <p>Contractor’s/ Vendor’s Engineering Coordinator (VENDOR EC):</p> <p>Name : _____</p> <p>Designation : _____</p>			
<p>TALCHER THERMAL POWER PROJECT STAGE-III (2X660 MW) EPC PACKAGE</p>	<p>TECHNICAL SPECIFICATIONS SECTION VI, PART-C BID DOC. NO.:CS-4540-001A-2</p>	<p>GENERAL TECHNICAL REQUIREMENTS</p>	<p>PAGE 22 OF 114</p>	

CLAUSE NO.	GENERAL TECHNICAL REQUIREMENTS			
	Address : a) Postal : b) Telegraphic / e-Mail : c) FAX : TELEPHONE :			
8.05.02	All engineering correspondence shall be in the name of above coordinators on behalf of the respective organizations.			
8.05.03	Contractor's/Vendor's Drawing Submission and Approval Procedure: a) All data/information furnished by Vendor in the form of drawings/ documents/catalogues or in any other form for NTPC's information/ interface and or review and approval are referred by the general term "drawings". b) Not used c) All drawings (including those of subvendor's) shall bear at the right hand bottom corner the 'title plate' with all relevant information duly filled in. The Contractor shall furnish this format to his sub-vendor along with his purchase order for sub-vendor's compliance. d) Not used e) The contractor shall make a visit to site to see the existing facilities and understand the layout completely and collect all necessary data / drawings at site which are needed as an input to the engineering. The contractor shall do the complete engineering including interfacing and integration of all his equipment, systems & facilities within his scope of work as well as interface engineering & integration of systems, facilities, equipment & works under Employer's scope and submit all necessary drawings/ documents for the same. f) Drawings must be checked by the Contractor in terms of its completeness, data adequacy and relevance with respect to engineering schedule prior to submission to the Employer. In case drawings are found to be submitted without proper endorsement for checking by the Contractor, the same shall not be reviewed and returned to the Contractor for re-submission. g) The Contractor shall submit drawing / data / document for Employer's review and approval. The drawings submitted by the Contractor/vendor shall be reviewed by NTPC and their comments shall be forwarded within three (3) weeks of receipt of drawings. Upon review of each drawing, depending on			
TALCHER THERMAL POWER PROJECT STAGE-III (2X660 MW) EPC PACKAGE	TECHNICAL SPECIFICATIONS SECTION VI, PART-C BID DOC. NO.:CS-4540-001A-2	GENERAL TECHNICAL REQUIREMENTS	PAGE 23 OF 114	

CLAUSE NO.	GENERAL TECHNICAL REQUIREMENTS			
	<p>the correctness and completeness of the drawing, the same will be categorized and approval accorded in one of the following categories:</p> <p>CATEGORY- I: Approved</p> <p>CATEGORY- II Approved, subject to incorporation of comments/ modification as noted. Resubmit revised drawing incorporating the comments.</p> <p>CATEGORY –III Not approved. Resubmit revised drawings for approval after incorporating comments/ modification as noted.</p> <p>CATEGORY -IV For information and records.</p> <p>h) Contractor shall resubmit the drawings approved under Category II, III & IV within two (2) weeks of receipt of comments on the drawings, incorporating all comments. Every revision of the drawing shall bear a revision index wherein such revisions shall be highlighted in the form of description or marked up in the drawing identifying the same with relevant revision Number enclosed in a triangle (eg. 1, 2, 3 etc). Contractor shall not make any changes in the portions of the drawing other than those commented. If changes are required to be made in the portions already approved, the Contractor shall resubmit the drawing identifying the changes for Employer's review and approval. Drawings resubmitted shall show clearly the portions where the same are revised marking the relevant revision numbers and Employer shall review only such revised portion of documents.</p> <p>i) In case, the Contractor/ Vendor does not agree with any specific comment, he shall furnish the explanation for the same to NTPC for consideration. In all such cases the Contractor shall necessarily enclose explanations along with the revised drawing (taking care of balance comments) to avoid any delay and/or duplication in review work.</p> <p>j) It is responsibility of the Contractor/ Vendor to get all the drawings approved in the Category I & IV (as the case may be) and complete engineering activities within the agreed schedule. Any delay arising out of submission and modification of drawings shall not alter the contract completion schedule.</p> <p>k) If Contractor/ Vendor fails to resubmit the drawings as per the schedule, construction work at site will not be held up and work will be carried out on the basis of comments furnished on previous issues of the drawing.</p> <p>l) These comments will be taken care by the contractor while submitting the revised drawing.</p>			
<p>TALCHER THERMAL POWER PROJECT STAGE-III (2X660 MW) EPC PACKAGE</p>	<p>TECHNICAL SPECIFICATIONS SECTION VI, PART-C BID DOC. NO.:CS-4540-001A-2</p>	<p>GENERAL TECHNICAL REQUIREMENTS</p>	<p>PAGE 24 OF 114</p>	

CLAUSE NO.	GENERAL TECHNICAL REQUIREMENTS			
	<p>The contractor shall use a single transmittal for drawings. Submission. This shall include transmittal numbers and date, number of copies being sent, names of the agencies to whom copies being sent, drawing number and titles, remarks or special notes if any etc.</p>			
8.06.00	ENGINEERING PROGRESS AND EXCEPTION REPORT			
8.06.01	<p>The Contractor shall submit every month an Engineering progress and Exception Report giving the status of each engineering information including</p> <p>a) A list of drawings/engineering information which remains unapproved for more than four (4) weeks after the date of first submission</p> <p>b) Drawings which were not submitted as per agreed schedule.</p>			
8.06.02	<p>The draft format for this report shall be furnished to the Employer within four (4) weeks of the award of the contract, which shall then be discussed and finalised with the Employer.</p>			
9.00.00	TECHNICAL CO-ORDINATION MEETING			
9.01.00	<p>The Contractor shall be called upon to organise and attend monthly Design/ Technical Co-ordination Meetings (TCMs) with the Employer/Employer's representatives and other Contractors of the Employer during the period of contract. The Contractor shall attend such meetings at his own cost at NEW DELHI / NOIDA or at mutually agreed venue as and when required and fully co-operate with such persons and agencies involved during the discussions.</p>			
9.02.00	<p>The Contractor should note that Time is the essence of the contract. In order to expedite the early completion of engineering activities, the comments of the Employer shall be discussed across the table during the above Technical Co-ordination Meeting (s) wherein best efforts shall be made by both sides to ensure the approval of the drawing.</p>			
9.02.01	<p>The Contractor shall ensure availability of the concerned experts / consultants/ personnel who are empowered to take necessary decisions during these meetings. The Contractor shall be equipped with necessary tools and facilities so that the drawings/documents can be resubmitted after incorporating necessary changes and approved during the meeting itself.</p>			
9.02.02	<p>Should any drawing remain unapproved for more than six (6) weeks after it's first submission, this shall be brought out in the monthly Engineering Progress and Exception Report with reasons thereof.</p>			
TALCHER THERMAL POWER PROJECT STAGE-III (2X660 MW) EPC PACKAGE		TECHNICAL SPECIFICATIONS SECTION VI, PART-C BID DOC. NO.:CS-4540-001A-2	GENERAL TECHNICAL REQUIREMENTS	PAGE 25 OF 114

CLAUSE NO.	GENERAL TECHNICAL REQUIREMENTS	
9.03.0	<p>Any delays arising out of failure by the Contractor to incorporate Employer's comments and resubmit the same during the TCM shall be considered as a default and in no case shall entitle the Contractor to alter the Contract completion date.</p>	
10.00.00	<p>DESIGN IMPROVEMENTS</p> <p>The Employer or the Contractor may propose changes in the specification of the equipment or quality thereof and if the parties agree upon any such changes the specification shall be modified accordingly.</p> <p>If any such agreed upon change is such that it affects the price and schedule of completion, the parties shall agree in writing as to the extent of any changing the price and/or schedule of completion before the Contractor proceeds with the change. Following such agreement, the provision thereof, shall be deemed to have been amended accordingly.</p>	
11.00.00	<p>EQUIPMENT BASES</p> <p>A cast iron or welded steel base plate shall be provided for all rotating equipment which is to be installed on a concrete base, unless otherwise specifically agreed to by the Employer. Each base plate shall support the unit and its drive assembly, shall be of a neat design with pads for anchoring the units, shall have a raised lip all around, and shall have threaded drain connections.</p>	
12.00.00	<p>PROTECTIVE GUARDS</p> <p>Suitable guards shall be provided for protection of personnel on all exposed rotating and/or moving machine parts. All such guards shall be designed for easy installation and removal for maintenance purpose.</p>	
13.00.00	<p>LUBRICANTS, SERVO FLUIDS AND CHEMICALS</p>	
13.01.00	<p>All the first fill and one year's topping requirement of consumables such as greases, oils, lubricants, servo fluids / control fluids, gases (excluding H₂, CO₂ and N₂ for Generator) etc. which will be required to put the equipment covered under the scope of specifications into successful commissioning/initial operation and to establish completion of facilities shall be supplied by the contractor. Suitable standard lubricants as available in India are desired. Efforts should be made to limit the variety of lubricants to minimum.</p> <p>Bidder scope shall include supply of H₂, CO₂ and N₂ as applicable for the Generator till successful commissioning of Generator.</p> <p>Bidder shall supply a quantity not less than 10% of the full charge or one (1) year topping requirement mentioned above (Whichever is higher) of each variety of lubricants, servo fluids, gases etc. (as detailed above) used which is expected to be</p>	
<p>TALCHER THERMAL POWER PROJECT STAGE-III (2X660 MW) EPC PACKAGE</p>	<p>TECHNICAL SPECIFICATIONS SECTION VI, PART-C BID DOC. NO.:CS-4540-001A-2</p>	<p>GENERAL TECHNICAL REQUIREMENTS</p> <p>PAGE 26 OF 114</p>

CLAUSE NO.	GENERAL TECHNICAL REQUIREMENTS			
	utilized during the first year of operation. This additional quantity shall be supplied in separate containers.			
13.02.00	As far as possible lubricants marketed by the Indian Oil Corporation shall be used. The variety of lubricants shall be kept to a minimum possible.			
	Detailed specifications for the lubricating oil, grease, gases, servo fluids, control fluids, chemicals etc. required for the complete plant covered herein shall be furnished. On completion of erection, a complete list of bearings/ equipment giving their location and identification marks shall be furnished to the Employer alongwith lubrication requirements.			
14.00.00	LUBRICATION			
14.01.00	Equipment shall be lubricated by systems designed for continuous operation. Lubricant level indicators shall be furnished and marked to indicate proper levels under both standstill and operating conditions.			
15.00.00	MATERIAL OF CONSTRUCTION			
15.01.00	All materials used for the construction of the equipment shall be new and shall be in accordance with the requirements of this specification. Materials utilised for various components shall be those which have established themselves for use in such applications.			
16.00.00	RATING PLATES, NAME PLATES & LABELS			
16.01.00	Each main and auxiliary item of plant shall have permanently attached to it in a conspicuous position, a rating plate of non-corrosive material upon which shall be engraved manufacturer's name, equipment, type or serial number together with details of the ratings, service conditions under which the item of plant in question has been designed to operate, and such diagram plates as may be required by the Employer.			
16.02.00	Each item of plant shall be provided with nameplate or label designating the service of the particular equipment. The inscriptions shall be approved by the Employer or as detailed in appropriate section of the technical specifications.			
16.03.00	Such nameplates or labels shall be of white non-hygroscopic material with engraved black lettering or alternately, in the case of indoor circuit breakers, starters, etc. of transparent plastic material with suitably coloured lettering engraved on the back.			
16.04.00	Items of plant such as valves, which are subject to handling, shall be provided with an engraved chromium plated nameplate or label with engraving filled with enamel. The name plates for valves shall be marked in accordance with MSS standard SP-25 and ANSI B 16.34 as a minimum.			
TALCHER THERMAL POWER PROJECT STAGE-III (2X660 MW) EPC PACKAGE	TECHNICAL SPECIFICATIONS SECTION VI, PART-C BID DOC. NO.:CS-4540-001A-2	GENERAL TECHNICAL REQUIREMENTS	PAGE 27 OF 114	

CLAUSE NO.	GENERAL TECHNICAL REQUIREMENTS			
16.05.00	<p>Hanger/ support numbers shall be marked on all pipe supports, anchors, hangers, snubbers and restraint assemblies. Each constant and variable spring support shall also have stamped upon it the designed hot and cold load which it is intended to support.</p>			
16.06.00	<p>Valves, steam traps and strainers shall be identified by Employer's tag number of a metal tap permanently attached to non-pressure parts such as the yoke by a stainless steel wire. The direction of flow shall also be marked on the body.</p>			
16.07.00	<p>Safety and relief valves shall be provided with the following:</p> <ol style="list-style-type: none"> Manufacturer's identification. Nominal inlet and outlet sizes in mm. Set pressure in Kg/cm² (abs). Blowdown and accumulation as percentage of set pressure. Certified capacity in Kg of saturated steam per hour or in case of liquid certified capacity in litres of water per minute. 			
16.08.00	<p>All such plates, instruction plates, etc. shall be bilingual with Hindi inscription first, followed by English. Alternatively, two separate plates one with Hindi and the other with English inscriptions may be provided.</p>			
16.09.00	<p>All segregated phases of conductors or bus ducts, indoor or outdoor, shall be provided with coloured phase plates to clearly identify the phase of the system.</p>			
17.00.00	<p>TOOLS AND TACKLES</p> <p>The Contractor shall supply with the equipment one complete set of all special tools and tackles and other instruments required and other instruments for the erection, assembly, disassembly and proper maintenance of the plant and equipment and systems (including software). These special tools will also include special material handling equipment, jigs and fixtures for maintenance and calibration / readjustment, checking and measurement aids etc. A list of such tools and tackles shall be submitted by the Bidder alongwith the offer.</p> <p>The price of each tool / tackle shall be deemed to have been included in the total bid price. These tools and tackles shall be separately packed and sent to site. The Contractor shall also ensure that these tools and tackles are not used by him during erection, commissioning and initial operation. For this period the Contractor should bring his own tools and tackles. All the tools and tackles shall be of reputed make acceptable to the Employer.</p>			
<p>TALCHER THERMAL POWER PROJECT STAGE-III (2X660 MW) EPC PACKAGE</p>		<p>TECHNICAL SPECIFICATIONS SECTION VI, PART-C BID DOC. NO.:CS-4540-001A-2</p>	<p>GENERAL TECHNICAL REQUIREMENTS</p>	<p>PAGE 28 OF 114</p>

CLAUSE NO.	GENERAL TECHNICAL REQUIREMENTS			
18.00.00	WELDING			
18.01.00	If the manufacturer has special requirements relating to the welding procedures for welds at the terminals of the equipments to be performed by others the requirements shall be submitted to the Employer in advance of commencement of erection work.			
19.00.00	COLOUR CODE FOR ALL EQUIPMENTS/ PIPINGS/ PIPE SERVICES			
19.01.00	All equipment/ piping/ pipe services are to be painted by the Contractor in accordance with Employer's standard colour coding scheme, which will be furnished to the Contractor during detailed engineering stage.			
20.00.00	PROTECTION AND PRESERVATIVE SHOP COATING			
20.01.00	<p>PROTECTION</p> <p>All coated surfaces shall be protected against abrasion, impact, discoloration and any other damages. All exposed threaded portions shall be suitably protected with either metallic or a non-metallic protection device. All ends of all valves and piping and conduit equipment connections shall be properly sealed with suitable devices to protect them from damage. All primers/paints/coatings shall take into account the hot humid, corrosive & alkaline, subsoil or over ground environment as the case may be. The requirements for painting specification shall be complied with as detailed out in Part-A & B of the Technical Specification.</p>			
20.02.00	<p>PRESERVATIVE SHOP COATING</p> <p>All exposed metallic surfaces subject to corrosion shall be protected by shop application of suitable coatings. All surfaces which will not be easily accessible after the shop assembly, shall be treated beforehand and protected for the life of the equipment. All surfaces shall be thoroughly cleaned of all mill scales, oxides and other coatings and prepared in the shop. The surfaces that are to be finish-painted after installation or require corrosion protection until installation, shall be shop painted as per the requirements covered in the relevant part of the Technical Specification.</p> <p>Transformers and other electrical equipments, if included shall be shop finished with one or more coats of primer and two coats of high grade resistance enamel. The finished colors shall be as per manufacturer's standards, to be selected and specified by the Employer at a later date.</p>			
20.03.00	Shop primer for all steel surfaces which will be exposed to operating temperature below 95 degrees Celsius shall be selected by the Contractor after obtaining specific approval of the Employer regarding the quality of primer proposed to be applied. Special high temperature primer shall be used on surfaces exposed to temperature			
TALCHER THERMAL POWER PROJECT STAGE-III (2X660 MW) EPC PACKAGE		TECHNICAL SPECIFICATIONS SECTION VI, PART-C BID DOC. NO.:CS-4540-001A-2	GENERAL TECHNICAL REQUIREMENTS	PAGE 29 OF 114

CLAUSE NO.	GENERAL TECHNICAL REQUIREMENTS		
	<p>higher than 95 degrees Celsius and such primer shall also be subject to the approval of the Employer.</p>		
20.04.00	<p>All other steel surfaces which are not to be painted shall be coated with suitable dust preventive compound subject to the approval of the Employer.</p>		
20.05.00	<p>All piping shall be cleaned after shop assembly by shot blasting or other means approved by the Employer. Lube oil piping or carbon steel shall be pickled.</p>		
20.06.00	<p>Painting for Civil structures and equipment/system covered under this package shall be done as specified under technical requirements on civil works in relevant part of this specifications.</p>		
21.00.00	<p>QUALITY ASSURANCE PROGRAMME</p>		
21.01.00	<p>To ensure that the equipment and services under the scope of contract whether manufactured or performed within the Contractor's works or at his sub-contractor's premises or at the Employer's site or at any other place of work are in accordance with the specifications, the Contractor shall adopt suitable quality assurance programme to control such activities at all points, as necessary. Such programmes shall be outlined by the Contractor and shall be finally accepted by the Employer/authorised representative after discussions before the award of the contract. The QA programme shall be generally in line with ISO-9001/IS-14001. A quality assurance programme of the contractor shall generally cover the following:</p> <ol style="list-style-type: none"> a) His organisation structure for the management and implementation of the proposed quality assurance programme b) Quality System Manual c) Design Control System d) Documentation Control System e) Qualification data for Bidder's key Personnel. f) The procedure for purchase of materials, parts, components and selection of sub-contractor's services including vendor analysis, source inspection, incoming raw-material inspection, verification of materials purchased etc. g) System for shop manufacturing and site erection control including process controls and fabrication and assembly controls. h) Control of non-conforming items and system for corrective actions. i) Inspection and test procedure both for manufacture and field activities. 		
<p>TALCHER THERMAL POWER PROJECT STAGE-III (2X660 MW) EPC PACKAGE</p>	<p>TECHNICAL SPECIFICATIONS SECTION VI, PART-C BID DOC. NO.:CS-4540-001A-2</p>	<p>GENERAL TECHNICAL REQUIREMENTS</p>	<p>PAGE 30 OF 114</p>

CLAUSE NO.	GENERAL TECHNICAL REQUIREMENTS				
	<p>j) Control of calibration and testing of measuring testing equipments.</p> <p>k) System for Quality Audits.</p> <p>l) System for indication and appraisal of inspection status.</p> <p>m) System for authorising release of manufactured product to the Employer.</p> <p>n) System for handling storage and delivery.</p> <p>o) System for maintenance of records, and</p> <p>p) Furnishing of quality plans for manufacturing and field activities detailing out the specific quality control procedure adopted for controlling the quality characteristics relevant to each item of equipment/component .Formats for the same will be shared along with QA Coordination procedure.</p>				
22.00.00	GENERAL REQUIREMENTS - QUALITY ASSURANCE				
22.01.00	<p>All materials, components and equipment covered under this specification shall be procured, manufactured, erected, commissioned and tested at all the stages, as per a comprehensive Quality Assurance Programme. An indicative programme of inspection/tests to be carried out by the contractor for some of the major items is given in the respective technical specification. This is, however, not intended to form a comprehensive programme as it is the contractor's responsibility to draw up and implement such programme duly approved by the Employer. The detailed Quality Plans for manufacturing and field activities shall be drawn up by the Bidder and will be submitted to Employer for approval. Schedule of finalisation of such quality plans will be finalised before award on enclosed format No. QS-01-QAI-P-1/F3-R0. Monthly progress reports shall be furnished.</p>				
22.02.00	<p>Manufacturing Quality Plan will detail out for all the components and equipment, various tests/inspection, to be carried out as per the requirements of this specification and standards mentioned therein and quality practices and procedures followed by Contractor's/ Sub-contractor's/ sub-supplier's Quality Control Organisation, the relevant reference documents and standards, acceptance norms, inspection documents raised etc., during all stages of materials procurement, manufacture, assembly and final testing/performance testing. The Quality Plan shall be submitted on electronic media through C-folders, a web based system of NTPC ERP, for review and approval.</p>				
22.03.00	<p>Field Quality Plans will detail out for all the equipment, the quality practices and procedures etc. to be followed by the Contractor's "Site Quality Control Organisation", during various stages of site activities starting from receipt of materials/equipment at site.</p>				
<p>TALCHER THERMAL POWER PROJECT STAGE-III (2X660 MW) EPC PACKAGE</p>	<p>TECHNICAL SPECIFICATIONS SECTION VI, PART-C BID DOC. NO.:CS-4540-001A-2</p>	<p>GENERAL TECHNICAL REQUIREMENTS</p>	<p>PAGE 31 OF 114</p>		

CLAUSE NO.	GENERAL TECHNICAL REQUIREMENTS			
22.04.00	<p>The Bidder shall also furnish copies of the reference documents/plant standards/acceptance norms/tests and inspection procedure etc., as referred in Quality Plans along with Quality Plans. These Quality Plans and reference documents/standards etc. will be subject to Employer's approval without which manufacturer shall not proceed. These approved documents shall form a part of the contract. In these approved Quality Plans, Employer shall identify customer hold points (CHP), i.e. test/checks which shall be carried out in presence of the Employer's Project Manager or his authorised representative and beyond which the work will not proceed without consent of Employer in writing. All deviations to this specification, approved quality plans and applicable standards must be documented and referred to Employer along with technical justification for approval and dispositioning.</p>			
22.05.00	<p>The contractor shall submit to the Employer Field Welding Schedule for field welding activities in the format enclosed at Annexure-V. The field welding schedule shall be submitted to the Employer along with all supporting documents, like welding procedures, heat treatment procedures, NDT procedures etc. at least ninety days before schedule start of erection work at site.</p>			
22.06.00	<p>The contractor shall have suitable Field Quality Organization with adequate manpower at Employer's site, to effectively implement the Field Quality Plan (FQP) and Field Quality Management System for site activities. The contractor shall submit the details of proposed FQA setup (organizational structure and manpower) for employer's approval. The FQA setup shall be in place at least one month before the start of site activities.</p>			
22.07.00	<p>No material shall be despatched from the manufacturer's works before the same is accepted by Employer's Project Manager/Authorised representative and duly authorised for despatch by issuance of Material Dispatch Clearance Certificate (MDCC / CHP Clearance).</p>			
22.08.00	<p>All material used for equipment manufacture including casting and forging etc. shall be of tested quality as per relevant codes/standards. Details of results of the tests conducted to determine the mechanical properties; chemical analysis and details of heat treatment procedure recommended and actually followed shall be recorded on certificates and time temperature chart. Tests shall be carried out as per applicable material standards and/or agreed details</p>			
22.09.00	<p>All welding and brazing shall be carried out as per procedure drawn and qualified in accordance with requirements of ASME Section IX/BS-4870 or other International equivalent standard acceptable to the Employer.</p> <p>All welding/brazing procedures shall be submitted to the Employer or its authorized representative prior to carrying out the welding/brazing.</p>			
22.10.00	<p>All brazers, welders and welding operators employed on any part of the contract either in Contractor's/his sub-contractor's works or at site or elsewhere shall be</p>			
<p>TALCHER THERMAL POWER PROJECT STAGE-III (2X660 MW) EPC PACKAGE</p>	<p>TECHNICAL SPECIFICATIONS SECTION VI, PART-C BID DOC. NO.:CS-4540-001A-2</p>	<p>GENERAL TECHNICAL REQUIREMENTS</p>	<p>PAGE 32 OF 114</p>	

CLAUSE NO.	GENERAL TECHNICAL REQUIREMENTS		
	<p>qualified as per ASME Section-IX or BS-4871 or other equivalent International Standards acceptable to the Employer. All welding / brazing procedures qualified / used at shop, will be made available to NTPC during audit / inspection. Procedures to be qualified at site will be submitted to NTPC for approval.</p>		
22.11.00	Not Used.		
22.12.00	<p>For all IBR pressure parts and high pressure piping welding, the latest applicable requirements of the IBR (Indian Boiler Regulations) shall also be essentially complied with. However, other piping shall be as per relevant code. Similarly, any other statutory requirements for the equipment/systems shall also be complied with. On all back-gauged welds MPI/LPI shall be carried before seal welding</p>		
22.13.00	<p>All the heat treatment results shall be recorded on time temperature charts and verified with recommended regimes.</p>		
22.14.00	<p>No welding shall be carried out on cast iron components for repair.</p>		
22.15.00	<p>Unless otherwise proven and specifically agreed with the Employer, welding of dissimilar materials and high alloy materials shall be carried out at shop only.</p>		
22.16.00	<p>All non-destructive examination shall be performed in accordance with written procedures as per International Standards, The NDT operator shall be qualified as per SNT-TC-IA (of the American Society of non-destructive examination). NDT shall be recorded in a report, which includes details of methods and equipment used, result/evaluation, job data and identification of personnel employed and details of co-relation of the test report with the job.</p>		
	<p>In general all plates of thickness greater than 40mm & for pressure parts plates of thickness equal to or greater than 25mm shall be ultrasonically tested otherwise as specified in respective equipment specification. All bar stock/Forging of diameter equal to or greater than 40 mm shall be Ultrasonically tested.</p>		
22.17.00	<p>The Contractor shall list out all major items/ equipment/ components to be manufactured in house as well as procured from sub-contractors (BOI).</p> <p>All the sub-vendors proposed by the Main contractor for procurement of major bought out items including castings, forgings, semi-finished and finished components/equipment etc., list of which shall be drawn up by the Contractor and finalised with the Employer, shall be subject to Employer's approval on enclosed format as Annexure-III.</p> <p>List of NTPC approved sub vendors against similar Pkg/items is attached as Section-VI, Part-B ,Chapter E-60 Indicative sub-vendor list.</p> <p>The contractor's proposal for any new sub vendor for any of the items identified in indicative sub-vendor list shall necessarily be furnished in the sub vendor questionnaire & main Contractor Evaluation report format attached as Annexure- VII with all relevant documents and main contractor's own assessment report</p>		
<p>TALCHER THERMAL POWER PROJECT STAGE-III (2X660 MW) EPC PACKAGE</p>	<p>TECHNICAL SPECIFICATIONS SECTION VI, PART-C BID DOC. NO.:CS-4540-001A-2</p>	<p>GENERAL TECHNICAL REQUIREMENTS</p>	<p>PAGE 33 OF 114</p>

CLAUSE NO.	GENERAL TECHNICAL REQUIREMENTS			
	<p>assessed as per their quality management system for NTPC review and acceptance .</p> <p>New sub vendor proposal will only be considered for NTPC review, provided the proposal is received sufficiently in time: 90 days prior to ordering date of a Bought-Out Items/Start of Manufacturing so as not to impede the progress of the contract.</p> <p>Major checks and quality requirements as mentioned below shall necessarily be assessed by main contractor and complied with documentary support in case the same is not the part of their Quality management system.</p> <ol style="list-style-type: none"> i. Duly Filled Main supplier Evaluation Report. ii. Duly Filled Sub-Supplier Questionnaire. iii. Factory Registration Certificate. iv. Overall Organization Chart with Manpower details (Design, Manufacturing, Quality etc.) v. Supply reference list of the Sub-Supplier indicating similar product supply order reference no., customer name, rating of product, date /year of supply, date / year of commissioning. vi. List of Manufacturing Equipment available with sub vendor. vii. List of Testing Equipment available with sub vendor. viii. Manufacturing process execution plan with flow chart indicating various stages of manufacturing from raw material to finished product including outsourced process, if any. ix. Details of Outsourced Manufacturing Processes, if any. x. Quality control exercised during receipt, in-process & final inspection. xi. Compliance of Statutory requirements (As applicable) <p>After first submission of proposal to NTPC , In absence of relevant documents/ Incompleteness of the proposal, The main contractor will be given a period of maximum 10 days to submit the compliance of the NTPC comments. In case of noncompliance it will be presumed that main contractor is not serious about pursuing the proposal & the proposal will be foreclosed.</p> <p>The proposed Sub vendor will be assessed broadly on following criteria</p> <ol style="list-style-type: none"> i) Quality Management System Compliance including raw material/BOI control, traceability & control over outsources process ii) Design Capabilities (As applicable) iii) Manufacturing, Testing & Storage Facility iv) Processing Capabilities v) Supply Experience vi) Safety Aspect <p>In case of major observations or non-compliance observed during sub vendor works visit (Jointly with the main contractor) with respect to the submitted documents, proposed sub vendor will not be considered for acceptance and Main contractor will be solely responsible in such cases.</p> <p>Monthly progress reports on sub-vendor detail. Submission / approval shall be furnished preferably on enclosed format at Annexure-IV. Such vendor approval shall not relieve the contractor from any obligation, duty or responsibility under the contract.</p>			
<p>TALCHER THERMAL POWER PROJECT STAGE-III (2X660 MW) EPC PACKAGE</p>	<p>TECHNICAL SPECIFICATIONS SECTION VI, PART-C BID DOC. NO.:CS-4540-001A-2</p>	<p>GENERAL TECHNICAL REQUIREMENTS</p>	<p>PAGE 34 OF 114</p>	

CLAUSE NO.	GENERAL TECHNICAL REQUIREMENTS			
22.18.00	<p>For components/equipment procured by the contractors for the purpose of the contract, after obtaining the written approval of the Employer, the contractor's purchase specifications and inquiries shall call for quality plans to be submitted by the suppliers. The quality plans called for from the sub-contractor shall set out, during the various stages of manufacture and installation, the quality practices and procedures followed by the vendor's quality control organisation, the relevant reference documents/standards used, acceptance level, inspection of documentation raised, etc. Such quality plans of the successful vendors shall be finalised with the Employer and such approved Quality Plans shall form a part of the purchase order/contract between the Contractor and sub-contractor. Within two (2) weeks of the release of the purchase orders /contracts for such bought out items /components, a copy of the same without price details but together with the detailed purchase specifications, quality plans and delivery conditions shall be furnished to the Employer on the monthly basis by the Contractor along with a report of the Purchase Order placed so far for the contract.</p>			
22.19.00	<p>Employer reserves the right to carry out quality audit and quality surveillance of the systems and procedures of the Contractor's or their sub-contractor's quality management and control activities. The contractor shall provide all necessary assistance to enable the Employer carry out such audit and surveillance.</p>			
22.20.00	<p>The contractor shall carry out an inspection and testing programme during manufacture in his work and that of his subcontractor's and at site to ensure the mechanical accuracy of components, compliance with drawings, conformance to functional and performance requirements, identity and acceptability of all materials parts and equipment. Contractor shall carry out all tests/inspection required to establish that the items/equipment conform to requirements of the specification and the relevant codes/standards specified in the specification, in addition to carrying out tests as per the approved quality plan.</p>			
22.21.00	<p>Quality audit/surveillance/approval of the results of the tests and inspection will not, however, prejudice the right of the Employer to reject the equipment if it does not comply with the specification when erected or does not give complete satisfaction in service and the above shall in no way limit the liabilities and responsibilities of the Contractor in ensuring complete conformance of the materials/equipment supplied to relevant specification, standard, data sheets, drawings, etc.</p>			
22.22.00	<p>For all spares and replacement items, the quality requirements as agreed for the main equipment supply shall be applicable.</p>			
22.23.00	<p>Repair/rectification procedures to be adopted to make the job acceptable shall be subject to the approval of the Employer/ authorised representative.</p>			
22.24.00	<p>Environmental Stress Screening</p> <p>Environmental stress screening test process / procedure for eliminating infant mortile components for DDCMIS / PLC based system & for other systems having</p>			
<p>TALCHER THERMAL POWER PROJECT STAGE-III (2X660 MW) EPC PACKAGE</p>	<p>TECHNICAL SPECIFICATIONS SECTION VI, PART-C BID DOC. NO.:CS-4540-001A-2</p>	<p>GENERAL TECHNICAL REQUIREMENTS</p>	<p>PAGE 35 OF 114</p>	

CLAUSE NO.	GENERAL TECHNICAL REQUIREMENTS			
	<p>substantial electronics components (as determined by employer) like Electronic transmitter, CCTV components, PA systems etc. shall be furnished for NTPC acceptance</p>			
22.25.00	<p>The Contractor / Sub-contractor shall carry out routine test on 100% item at contractor / sub-contractor's works. The quantum of check / test for routine & acceptance test by employer shall be generally as per criteria / sampling plan defined in referred standards. Wherever standards have not been mentioned quantum of check / test for routine / acceptance test shall be as agreed during detailed engineering stage.</p>			
22.26.00	<p>Software Reliability / Quality Certification</p> <p>Certification from OEM's authorized signatory that software offered with DDCMIS, PLC, CCTV, PA, Pyrometer, CEMS, AAQMS, EQMS, BHMS etc. declaring that the all the offered software(s) had gone through the established software quality test and offered software is not of β-version and offered software is also free from all known bugs as on date of approval of systems documents by NTPC as a part of quality documentation review and approval process during detail engineering.</p>			
23.00.00	<p>QUALITY ASSURANCE DOCUMENTS</p>			
23.01.00	<p>The Contractor shall be required to submit the QA Documentation in soft copies, as identified in respective quality plan with tick (✓) mark.</p>			
23.01.01	<p>Each QA Documentation shall have a project specific Cover Sheet bearing name & identification number of equipment and including an index of its contents with page control on each document.</p>			
23.02.00	<p>The QA Documentation file shall be progressively completed by the Supplier's sub-supplier to allow regular reviews by all parties during the manufacturing.</p> <p>The final quality document will be compiled and issued at the final assembly place of equipment before despatch. However, soft copies will be furnished not later than two (2) weeks.</p>			
23.02.00	<p>Typical contents of QA Documentation is as below:-</p> <ul style="list-style-type: none"> (a.) Quality Plan (b.) Material mill test reports on components as specified by the specification and approved Quality Plans. (c.) Manufacturer / works test reports/results for testing required as per applicable codes and standard referred in the specification and approved Quality Plans. (d.) Non-destructive examination results /reports including radiography interpretation reports. Sketches/drawings used for indicating the method of traceability of the radiographs to the location on the equipment. 			
<p>TALCHER THERMAL POWER PROJECT STAGE-III (2X660 MW) EPC PACKAGE</p>	<p>TECHNICAL SPECIFICATIONS SECTION VI, PART-C BID DOC. NO.:CS-4540-001A-2</p>	<p>GENERAL TECHNICAL REQUIREMENTS</p>	<p>PAGE 36 OF 114</p>	

CLAUSE NO.	GENERAL TECHNICAL REQUIREMENTS			
	(e.) Heat Treatment Certificate/Record (Time- temperature Chart) (f.) All the accepted Non-conformance Reports (Major/Minor)/deviation, including complete technical details / repair procedure). (g.) CHP / Inspection reports duly signed by the Inspector of the Employer and Contractor for the agreed Customer Hold Points. (h.) Certificate of Conformance (COC) wherever applicable. (i.) MDCC			
23.03.00	Similarly, the contractor shall be required to submit soft copies containing QA Documentation pertaining to field activities as per Approved Field Quality Plans and other agreed manuals/ procedures, prior to commissioning of individual system.			
23.04.00	Before despatch / commissioning of any equipment, the Supplier shall make sure that the corresponding quality document or in the case of protracted phased deliveries, the applicable section of the quality document file is completed. The supplier will then notify the Inspector regarding the readiness of the quality document (or applicable section) for review. (a.) If the result of the review carried out by the Inspector is satisfactory, the Inspector shall stamp the quality document (or applicable section) for release. (b.) If the quality document is unsatisfactory, the Supplier shall endeavor to correct the incompleteness, thus allowing to finalize the quality document (or applicable section) by time compatible with the requirements as per contract documents. When it is done, the quality document (or applicable section) is stamped by the Inspector. (c.) If a decision is made for despatch, whereas all outstanding actions cannot be readily cleared for the release of the quality document by that time, the supplier shall immediately, upon shipment of the equipment, send a copy of the quality document Review Status signed by the Supplier Representative to the Inspector and notify of the committed date for the completion of all outstanding actions & submission. The Inspector shall stamp the quality document for applicable section when it is effectively completed. The submission of QA documentation package shall not be later than two (2) weeks after the despatch of equipment.			
TALCHER THERMAL POWER PROJECT STAGE-III (2X660 MW) EPC PACKAGE	TECHNICAL SPECIFICATIONS SECTION VI, PART-C BID DOC. NO.:CS-4540-001A-2	GENERAL TECHNICAL REQUIREMENTS	PAGE 37 OF 114	

CLAUSE NO.	GENERAL TECHNICAL REQUIREMENTS			
23.05.00	<p>TRANSMISSION OF QA DOCUMENTATION</p> <p>On release of QA Documentation by Inspector, one set of quality document shall be forwarded to Corporate Quality Assurance Department and other set to respective Project Site of Employer.</p> <p>For the particular case of phased deliveries, the complete quality document to the Employer shall be issued not later than two (2) weeks after the date of the last delivery of equipment.</p>			
24.00.00	<p>PROJECT MANAGER'S SUPERVISION</p>			
24.01.00	<p>To eliminate delays and avoid disputes and litigation, it is agreed between the parties to the Contract that all matters and questions shall be referred to the Project Manager and without prejudice to the provisions of 'Arbitration' clause in Section GCC, the Contractor shall proceed to comply with the Project Manager's decision.</p>			
24.02.00	<p>The work shall be performed under the supervision of the Project Manager.</p> <p>The scope of the duties of the Project Manager pursuant to the Contract, will include but not be limited to the following:</p> <ul style="list-style-type: none"> (a.) Interpretation of all the terms and conditions of these documents and specifications (b.) Review and interpretation of all the Contractor's drawing, engineering data, etc. (c.) Witness or his authorised representative to witness tests and trials either at the manufacturer's works or at site, or at any place where work is performed under the contract (d.) Inspect, accept or reject any equipment, material and work under the contract (e.) Issue certificate of acceptance and/or progressive payment and final payment certificates (f.) Review and suggest modifications and improvement in completion schedules from time to time, and (g.) Supervise Quality Assurance Programme implementation at all stages of the works. 			
<p>TALCHER THERMAL POWER PROJECT STAGE-III (2X660 MW) EPC PACKAGE</p>	<p>TECHNICAL SPECIFICATIONS SECTION VI, PART-C BID DOC. NO.:CS-4540-001A-2</p>	<p>GENERAL TECHNICAL REQUIREMENTS</p>	<p>PAGE 38 OF 114</p>	

CLAUSE NO.	GENERAL TECHNICAL REQUIREMENTS			
25.00.00	INSPECTION, TESTING AND INSPECTION CERTIFICATES			
25.01.00	The word 'Inspector' shall mean the Project Manager and/or his authorised representative and/or an outside inspection agency acting on behalf of the Employer to inspect and examine the materials and workmanship of the works during its manufacture or erection.			
25.02.00	The Project Manager or his duly authorised representative and/or an outside inspection agency acting on behalf of the Employer shall have access at all reasonable times to inspect and examine the materials and workmanship of the works during its manufacture or erection and if part of the works is being manufactured or assembled on other premises or works, the Contractor shall obtain for the Project Manager and for his duly authorised representative permission to inspect as if the works were manufactured or assembled on the Contractor's own premises or works.			
25.03.00	The Contractor shall give the Project Manager/Inspector fifteen (15) days written notice of any material being ready for testing. Such tests shall be to the Contractor's account except for the expenses of the Inspector's. The Project Manager/Inspector, unless the witnessing of the tests is virtually waived and confirmed in writing, will attend such tests within fifteen (15) days of the date on which the equipment is noticed as being ready for test/inspection failing which the contractor may proceed with test which shall be deemed to have been made in the inspector's presence and he shall forthwith forward to the inspector duly certified copies of test reports in two (2) copies.			
25.04.00	The Project Manager or Inspector shall within fifteen (15) days from the date of inspection as defined herein give notice in writing to the Contractor, or any objection to any drawings and all or any equipment and workmanship which is in his opinion not in accordance with the contract. The Contractor shall give due consideration to such objections and shall either make modifications that may be necessary to meet the said objections or shall inform in writing to the Project Manager/Inspector giving reasons therein, that no modifications are necessary to comply with the contract.			
25.05.00	When the factory tests have been completed at the Contractor's or subcontractor's works, the Project Manager /Inspector shall issue a certificate to this effect fifteen (15) days after completion of tests but if the tests are not witnessed by the Project Manager /Inspectors, the certificate shall be issued within fifteen (15) days of the receipt of the Contractor's test certificate by the Project Manager /Inspector. Failure on the part of Project Manager /Inspector to issue such a certificate shall not prevent the Contractor from proceeding with the works. The completion of these tests or the issue of the certificates shall not bind the Employer to accept the equipment should it, on further tests after erection be found not to comply with the contract.			
TALCHER THERMAL POWER PROJECT STAGE-III (2X660 MW) EPC PACKAGE		TECHNICAL SPECIFICATIONS SECTION VI, PART-C BID DOC. NO.:CS-4540-001A-2	GENERAL TECHNICAL REQUIREMENTS	PAGE 39 OF 114

CLAUSE NO.	GENERAL TECHNICAL REQUIREMENTS	
25.06.00	<p>In all cases where the contract provides for tests whether at the premises or works of the Contractor or any sub-contractor, the Contractor, except where otherwise specified shall provide free of charge such items as labour, material, electricity, fuel, water, stores, apparatus and instruments as may be reasonably demanded by the Project Manager /Inspector or his authorised representatives to carry out effectively such tests on the equipment in accordance with the Contractor and shall give facilities to the Project Manager/Inspector or to his authorised representative to accomplish testing.</p>	
25.07.00	<p>The inspection by Project Manager / Inspector and issue of Inspection Certificate thereon shall in no way limit the liabilities and responsibilities of the Contractor in respect of the agreed Quality Assurance Programme forming a part of the contract.</p>	
25.08.00	<p>To facilitate advance planning of inspection in addition to giving inspection notice as specified at clause no. 25.03.00 - of this chapter, the Contractor shall furnish quarterly inspection programme indicating schedule dates of inspection at Customer Hold Point and final inspection stages. Updated quarterly inspection plans will be made for each three consecutive months and shall be furnished before beginning of each calendar month.</p>	
25.09.00	<p>All inspection, measuring and test equipment used by contractor shall be calibrated periodically depending on its use and criticality of the test/measurement to be done. The Contractor shall maintain all the relevant records of periodic calibration and instrument identification, and shall produce the same for inspection by NTPC. Wherever asked specifically, the contractor shall re-calibrate the measuring/test equipment in the presence of Project Manager / Inspector.</p>	
25.10.00	<p>ASSOCIATED DOCUMENT FOR QUALITY ASSURANCE PROGRAMME</p>	
25.10.01	<p>List of items requiring quality plan and sub supplier approval. Format No.: QS-01-QAI-P-01/F3-R0 (Annexure-III).</p>	
25.10.02	<p>Status of items requiring Quality Plan and sub supplier approval. Format enclosed at Annexure-IV.</p>	
25.10.03	<p>Field Welding Schedule Format enclosed at Annexure-V.</p>	
25.11.00	<p>TESTING OF MAJOR DESIGN FEATURES:</p> <p>The major design features of the system shall be demonstrated by the Contractor at the Contractor's works or any other place mutually agreed within Six months from the date of LOA. These are the system function tests, which have a major impact on the detailed system design & finalization of important engineering documents like configuration, functional grouping, BOM etc., but do not require a fully engineered system for conductance. Bidder shall identify these features & include detailed test procedures in the bid, which shall be finalized during discussions with the bidder</p>	
<p>TALCHER THERMAL POWER PROJECT STAGE-III (2X660 MW) EPC PACKAGE</p>	<p>TECHNICAL SPECIFICATIONS SECTION VI, PART-C BID DOC. NO.:CS-4540-001A-2</p>	<p>GENERAL TECHNICAL REQUIREMENTS</p> <p>PAGE 40 OF 114</p>

CLAUSE NO.	GENERAL TECHNICAL REQUIREMENTS			
25.12.00 25.12.01	<p>before award. The developments and any augmentation of standard features undertaken by the Bidder to fulfill the various specification requirements, shall be also be tested during these major design tests. This shall include but not be limited to the following.</p> <ol style="list-style-type: none"> a) System accuracy tests of DDCMIS for the various type of inputs identified in Part-B. b) Loop reaction time for sample loops/ logics. c) SOE functionality tests. d) Server changeover. e) Various response times, having serious implication on operation & maintenance philosophy. f) Duty cycle of controller/ HMIPIS with simulated load, representative of the final engineered load. g) Connectivity of Switchgear DDCMIS with Switchgear Relay Network. <p>The results of the above tests, after its acceptance by the Employer, shall be properly documented and submitted to Employer.</p> <p>If any of the envisaged tests have been carried out by Bidder in a previous NTPC project, then the same need not be specifically conducted by the Bidder for this project, provided it is clearly established by the Bidder & accepted by the Employer that there is no difference between the system offered for this project & the previous NTPC project with respect to the test. However, even in such a case, test report of the previous project shall be submitted by the Bidder as a part of MDFT (Major Design Feature Test) test report.</p> <p>DEMONSTRATION OF APPLICATION ENGINEERING</p> <p>Contractor shall prepare and submit typical implemented scheme in their system (Control system & HMI) on sample basis. The typical cases to be covered shall include but not be limited to the following.</p> <ol style="list-style-type: none"> (i) Logics/Loops: <ol style="list-style-type: none"> a) Drive logics implementation for each type of binary drive along with its display in HMI. b) Sequence implementation along with its display in HMI. 			
<p>TALCHER THERMAL POWER PROJECT STAGE-III (2X660 MW) EPC PACKAGE</p>	<p>TECHNICAL SPECIFICATIONS SECTION VI, PART-C BID DOC. NO.:CS-4540-001A-2</p>	<p>GENERAL TECHNICAL REQUIREMENTS</p>	<p>PAGE 41 OF 114</p>	

CLAUSE NO.	GENERAL TECHNICAL REQUIREMENTS			
25.12.02	<ul style="list-style-type: none"> c) Single non-cascade controller implementation. d) Cascade loop implementation. e) Master slave implementation with different slave combination. f) Temperature & pressure compensation for flow signals & pressure compensation for level signals as applicable. <p>(ii) HMI Functions:</p> <ul style="list-style-type: none"> a) LVS Annunciation. b) Graphics. c) HSR d) Logs/Reports. e) Calculations (Basic & Performance Calculations). <p>The above typical cases shall be finalized with the Employer through Technical Co-ordination meetings.</p> <p>After review and finalization of the typical cases, the implementation of each logic & control loop shall be carried out by the Contractor. After implementation of these logics & loops, the Contractor shall test each logic /loop and record the observations and demonstrate to Employer at Employer premises during engineering finalization. Any modifications as a result of the demonstration shall be done and documented as part of the test report along with the final scheme. Similarly, HMI functions shall also be demonstrated by the Contractor at Employer premises & the results shall be documented as part of test report.</p>			
25.12.03	<p>During the integrated testing at the Contractor's works, only sample checks shall be done by the Employer for the items covered in above application engineering demonstration.</p>			
26.00.00	PRE-COMMISSIONING AND COMMISSIONING FACILITIES			
26.01.00	<p>(a) As soon as the facilities or part thereof has been completed operationally and structurally and before start-up, each item of the equipment and systems forming part of facilities shall be thoroughly cleaned and then inspected jointly by the Employer and the Contractor for correctness of and completeness of facility or part thereof and acceptability for initial pre-commissioning tests, commissioning and start-up at Site. The list of pre-commissioning tests to be performed shall be as mutually agreed and</p>			
<p>TALCHER THERMAL POWER PROJECT STAGE-III (2X660 MW) EPC PACKAGE</p>	<p>TECHNICAL SPECIFICATIONS SECTION VI, PART-C BID DOC. NO.:CS-4540-001A-2</p>	<p>GENERAL TECHNICAL REQUIREMENTS</p>	<p>PAGE 42 OF 114</p>	

CLAUSE NO.	GENERAL TECHNICAL REQUIREMENTS			
	<p>included in the Contractor's quality assurance programme as well as those included in Part-D, Section-VI and elsewhere in the Technical Specifications.</p> <p>(b) The Contractor's pre-commissioning/ commissioning/start-up engineers, specially identified as far as possible, shall be responsible for carrying out all the pre-commissioning tests at Site. On completion of inspection, checking and after the pre-commissioning tests are satisfactorily over, the commissioning of the complete facilities shall be commenced during which period the complete facilities, equipments shall be operated integral with sub-systems and supporting equipment as a complete plant.</p> <p>(c) All piping system shall be flushed, steam blown, air blown as required and cleanliness demonstrated using acceptable industry standards. Procedures to accomplish this work shall be submitted for approval to the Employer six months prior to the respective implementations. The Employer will approve final verification of cleanliness.</p> <p>(d) The time consumed in the inspection and checking of the units shall be considered as a part of the erection and installation period.</p> <p>(e) The check outs during the pre-commissioning period should be programmed to follow the construction completion schedule. Each equipment/system, as it is completed in construction and turned over to Employer's commissioning (start-up) Engineer(s), should be checked out and cleaned. The checking and inspection of individual systems should then follow a prescribed schedule to be agreed by Employer.</p> <p>(f) The Contractor during initial operation and performance testing shall conduct vibration testing to determine the 'base line' of performance of all plant rotating equipment. These tests shall be conducted when the equipment is running at the base load, peak load as well as lowest sustained operating condition as far as practicable.</p>			
26.01.00	<p>Contractor shall furnish the commissioning organization chart for review & acceptance of employer at least eighteen months prior to the schedule date of synchronization of 1st unit. The chart should contain:</p> <p>(1.) Biodata including experience of the Commissioning Engineers. (2.) Role and responsibilities of the Commissioning Organisation members. (3.) Expected duration of posting of the above Commissioning Engineers at site.</p>			
26.02.00	<p>Initial Operation</p> <p>(a) On completion of all pre-commissioning activities/ tests and as a part of commissioning the complete facilities shall be put on 'Initial Operation' during which period all necessary adjustments shall be made while operating over the full load range enabling the facilities to be made ready for the Guarantee Tests.</p>			
<p>TALCHER THERMAL POWER PROJECT STAGE-III (2X660 MW) EPC PACKAGE</p>	<p>TECHNICAL SPECIFICATIONS SECTION VI, PART-C BID DOC. NO.:CS-4540-001A-2</p>	<p>GENERAL TECHNICAL REQUIREMENTS</p>	<p>PAGE 43 OF 114</p>	

CLAUSE NO.	GENERAL TECHNICAL REQUIREMENTS			
26.03.00	<p>(b) The 'Initial Operation' of the complete facility as an integral unit shall be conducted for 720 continuous hours. During the period of initial operation of 720 hours, the unit shall operate continuously at full rated load for a period not less than 72 hours.</p> <p>The Initial Operation shall be considered successful, provided that each item/ part of the facility can operate continuously at the specified operating characteristics, for the period of Initial Operation with all operating parameters within the specified limits and at or near the predicted performance of the equipment/ facility.</p> <p>The Contractor shall intimate the Employer about the commencement of initial operation and shall furnish adequate notice to the Employer in this respect.</p> <p>(c) Any loss of generation due to constraints attributable to the Employer shall be construed as Deemed Generation.</p> <p>(d) An Initial Operation report comprising of observations and recordings of various parameters to be measured in respect of the above Initial Operation shall be prepared by the Contractor. This report, besides recording the details of the various observations during initial operation shall also include the dates of start and finish of the Initial Operation and shall be signed by the representatives of both the parties. The report shall have sheets, recording all the details of interruptions occurred, adjustments made and any minor repairs done during the Initial Operation. Based on the observations, necessary modifications/repairs to the plant shall be carried out by the Contractor to the full satisfaction of the Employer to enable the latter to accord permission to carry out the Guarantee tests on the facilities. However, minor defects which do not endanger the safe operation of the equipment, shall not be considered as reasons for with- holding the aforesaid permission.</p> <p>Guarantee Tests</p> <p>a) The final test as to prove the Functional Guarantees shall be conducted at Site by the Contractor in presence of the Employer. The contractor's Commissioning, start-up Engineer shall make the unit ready to conduct such test before start of initial operation. Such test shall be conducted along with the Initial Operations.</p> <p>b) These tests shall be binding on both the parties of the Contract to determine compliance of the equipment with the functional guarantee.</p> <p>c) For performance/ demonstration tests instrumentations, of accuracy class shall be as per specified test codes. The numbers and location of the instruments shall be as per the specified test codes. In addition the values of parameters shall be logged from the information system provided under Employer's Distributed Digital Control Monitoring and Information system. Test will be conducted at specified load points.</p>			
TALCHER THERMAL POWER PROJECT STAGE-III (2X660 MW) EPC PACKAGE	TECHNICAL SPECIFICATIONS SECTION VI, PART-C BID DOC. NO.:CS-4540-001A-2	GENERAL TECHNICAL REQUIREMENTS	PAGE 44 OF 114	

CLAUSE NO.	GENERAL TECHNICAL REQUIREMENTS			
26.04.00	<p>d) Any special equipment, tools and tackles required for the successful completion of the Guarantee Tests shall be provided by the Contractor, free of cost.</p> <p>e) The Guarantee tests and specific tests to be conducted on equipments have been brought out in detail elsewhere in the specifications.</p> <p>Before start of commissioning of critical equipment, Commissioning Clearance Certificate (CCC) to be submitted by Main contractor. List of the critical equipments and CCC format will be provided along with QA Coordination procedure.</p>			
27.00.00	<p>TAKING OVER</p> <p>Upon successful completion of Initial Operations and all the tests conducted to the Employer's satisfaction, the Employer shall issue to the Contractor a Taking over Certificate as a proof of the final acceptance of the equipment. Such certificate shall not unreasonably be withheld nor will the Employer delay the issuance thereof, on account of minor omissions or defects which do not affect the commercial operation and/or cause any serious risk to the equipment. Such certificate shall not relieve the Contractor of any of his obligations which otherwise survive, by the terms and conditions of the Contract after issuance of such certificate.</p>			
28.00.00	<p>TRAINING OF EMPLOYER'S PERSONNEL</p>			
28.01.00	<p>The scope of service under training of Employer's engineers shall include a training module covering the areas of Operation & Maintenance.</p> <p>Such training should cover the following areas as a minimum in order to enable these personnel to individually take the responsibility of operating and maintaining the power station in a manner acceptable to the Employer:</p> <p>(a) Training for Steam Generator & ESP Equipment, TG & Auxiliaries and related equipments.</p> <p>(b) Training for Electric Systems including VFD and Electric power supply system.</p> <p>(c) Training for other SG/TG related C&I systems/equipments including training on Flame Monitoring System, Furnace and Flame Viewing System , Turbine Supervisory System (TSS) including vibration analyzer, vibration monitoring system axial shift, eccentricity measurements etc. for Main Turbine, BFP Turbine etc. Burner management study, control loop study, misc. system for SG C&I, EHTC, Turbine stress control system, Turbine protection system, ATRS, instrumentation etc.</p> <p>c1: Training on Engineering, Model building, pre-testing, Post -test fine tuning of Advance process control systems with faculty having experience of atleast 5 years in Model Process Control.</p> <p>(d) Training for special packages specified elsewhere in Technical Specification, Section-VI.</p>			
<p>TALCHER THERMAL POWER PROJECT STAGE-III (2X660 MW) EPC PACKAGE</p>	<p>TECHNICAL SPECIFICATIONS SECTION VI, PART-C BID DOC. NO.:CS-4540-001A-2</p>	<p>GENERAL TECHNICAL REQUIREMENTS</p>	<p>PAGE 45 OF 114</p>	

CLAUSE NO.	GENERAL TECHNICAL REQUIREMENTS			एनटीपीसी NTPC						
	<p>(e) Training for various C&I systems/equipment supplied includes the following:</p> <ul style="list-style-type: none"> i) DDCMIS - Human Machine Interface – Hardware & Operating System ii) DDCMIS-Human Machine Interface System Engineering & Application Software. iii) DDCMIS – Control System Hardware and Control system Application Software. iv) DDCMIS – Operator Training : Use of the system at Works + at site. v) DDCMIS – Specialized Network security. <p>(f) Training for power cycle piping/critical piping.</p> <p>(g) Training for UPS systems Annunciation system, SWAS, PA system, flue gas analyzers, CCTV and 24 VDC system.</p> <p>(h) Training on following aspects of fieldbus (i) Hardware & Software features (ii) System design, diagnostic and testing (iii) maintenance, troubleshooting and fault analysis.</p> <p>(i) Training on Non-Intrusive hardwired Electric Actuator and Fieldbus based Electric Actuator along with detail training on Foundation Fieldbus/ Profibus interface used in actuator</p> <p>(k) Training for numerical relays & networking systems supplied under MV & LT switchgear system.</p> <p>(l) Training courses on offered PLC system in the following areas:</p> <ul style="list-style-type: none"> (a.) Operator training (b.) Hardware Maintenance training (c.) Software training (d.) Any other specialized training as required for system operation and maintenance. <p>(m) Training for Ash Handling System & Coal Handling Plant Equipment and Auxiliaries</p> <table border="1" data-bbox="467 1556 1425 1812"> <thead> <tr> <th data-bbox="467 1556 626 1591">Area</th> <th data-bbox="630 1556 1263 1591">Topics</th> <th data-bbox="1266 1556 1425 1591">Mandays</th> </tr> </thead> <tbody> <tr> <td data-bbox="467 1593 626 1812">Ash Handling Plant</td> <td data-bbox="630 1593 1263 1812"> Product design - Basic design features - Theory & principle of operation - Latest technological trends in Ash handling plant and design Plant Visit - Operational feedback </td> <td data-bbox="1266 1593 1425 1812">300</td> </tr> </tbody> </table>				Area	Topics	Mandays	Ash Handling Plant	Product design - Basic design features - Theory & principle of operation - Latest technological trends in Ash handling plant and design Plant Visit - Operational feedback	300
Area	Topics	Mandays								
Ash Handling Plant	Product design - Basic design features - Theory & principle of operation - Latest technological trends in Ash handling plant and design Plant Visit - Operational feedback	300								
TALCHER THERMAL POWER PROJECT STAGE-III (2X660 MW) EPC PACKAGE	TECHNICAL SPECIFICATIONS SECTION VI, PART-C BID DOC. NO.:CS-4540-001A-2	GENERAL TECHNICAL REQUIREMENTS	PAGE 46 OF 114							

CLAUSE NO.	GENERAL TECHNICAL REQUIREMENTS								
		<ul style="list-style-type: none"> - O&M history/problems related to Ash handling plant Visit to Manufacturer's Work - Manufacturing process of Ash handling equipments - Testing facilities Operation & Maintenance of Plant - Trouble shooting and fault analysis - Familiarization of special maintenance techniques - Special tool and tackles familiarization 							
	<p style="text-align: center;">Coal Handling Plant</p>	<ul style="list-style-type: none"> Product design - Basic design features - Theory & principle of operation - Latest technological trends in Coal handling plant and design Plant Visit - Operational feedback - O&M history/problems related to Coal handling plant Visit to Manufacturer's Work - Manufacturing process of Coal handling equipments - Testing facilities Operation & Maintenance of Plant - Trouble shooting and fault analysis - Familiarization of special maintenance techniques - Special tool and tackles familiarization 	150						
	<p>n) Training for UF Membranes, RO membranes, Zero Liquid Discharge (ZLD) Chlorine Di-Oxide (ClO₂) generation & dosing system, Condensate Polishing Plant (CPU) and CW Treatment System.</p>								
	<table border="1" style="width: 100%; border-collapse: collapse;"> <thead> <tr> <th style="width: 20%;">Area</th> <th style="width: 60%;">Topics</th> <th style="width: 20%;">MANDAYS</th> </tr> </thead> <tbody> <tr> <td style="text-align: center;">UF Membranes</td> <td> Product design <ul style="list-style-type: none"> -Basic design features -Theory & principle of operation -Latest technological trends in Ultrafiltration membranes and design -CIP & CEB of UF system Plant Visit </td> <td style="text-align: center; vertical-align: top;">7</td> </tr> </tbody> </table>	Area	Topics	MANDAYS	UF Membranes	Product design <ul style="list-style-type: none"> -Basic design features -Theory & principle of operation -Latest technological trends in Ultrafiltration membranes and design -CIP & CEB of UF system Plant Visit	7		
Area	Topics	MANDAYS							
UF Membranes	Product design <ul style="list-style-type: none"> -Basic design features -Theory & principle of operation -Latest technological trends in Ultrafiltration membranes and design -CIP & CEB of UF system Plant Visit	7							
TALCHER THERMAL POWER PROJECT STAGE-III (2X660 MW) EPC PACKAGE	TECHNICAL SPECIFICATIONS SECTION VI, PART-C BID DOC. NO.:CS-4540-001A-2	GENERAL TECHNICAL REQUIREMENTS	PAGE 47 OF 114						

CLAUSE NO.	GENERAL TECHNICAL REQUIREMENTS			एनटीपीसी NTPC					
	<ul style="list-style-type: none"> -Operational feedback -O&M history/problems related to UF membranes Visit to Manufacturer's Work -Manufacturing process of UF membranes and equipment -Testing facilities Operation & Maintenance of Plant -Trouble shooting and fault analysis -Familiarization of special maintenance techniques -Special tool and tackles familiarization 								
	<table border="1" style="width: 100%; border-collapse: collapse;"> <thead> <tr> <th style="width: 15%;">Area</th> <th style="width: 60%;">Topics</th> <th style="width: 25%;">MANDAYS</th> </tr> </thead> <tbody> <tr> <td style="text-align: center;">RO membranes</td> <td> <p>Product design</p> <ul style="list-style-type: none"> -Basic design features -Theory & principle of operation -Latest technological trends in RO membranes and design -Failure analysis, types of failures, causes & its evaluation, remedies -CIP of RO system <p>Plant Visit</p> <ul style="list-style-type: none"> -Operational feedback -O&M history/problems related to RO membranes <p>Visit to Manufacturer's Work</p> <ul style="list-style-type: none"> -Manufacturing process of RO membranes and equipment -Testing facilities <p>Operation & Maintenance of Plant</p> <ul style="list-style-type: none"> -Trouble shooting and fault analysis -Familiarization of special maintenance techniques -Special tool and tackles familiarization </td> <td style="text-align: center; vertical-align: top;">7</td> </tr> </tbody> </table>	Area	Topics	MANDAYS	RO membranes	<p>Product design</p> <ul style="list-style-type: none"> -Basic design features -Theory & principle of operation -Latest technological trends in RO membranes and design -Failure analysis, types of failures, causes & its evaluation, remedies -CIP of RO system <p>Plant Visit</p> <ul style="list-style-type: none"> -Operational feedback -O&M history/problems related to RO membranes <p>Visit to Manufacturer's Work</p> <ul style="list-style-type: none"> -Manufacturing process of RO membranes and equipment -Testing facilities <p>Operation & Maintenance of Plant</p> <ul style="list-style-type: none"> -Trouble shooting and fault analysis -Familiarization of special maintenance techniques -Special tool and tackles familiarization 	7		
Area	Topics	MANDAYS							
RO membranes	<p>Product design</p> <ul style="list-style-type: none"> -Basic design features -Theory & principle of operation -Latest technological trends in RO membranes and design -Failure analysis, types of failures, causes & its evaluation, remedies -CIP of RO system <p>Plant Visit</p> <ul style="list-style-type: none"> -Operational feedback -O&M history/problems related to RO membranes <p>Visit to Manufacturer's Work</p> <ul style="list-style-type: none"> -Manufacturing process of RO membranes and equipment -Testing facilities <p>Operation & Maintenance of Plant</p> <ul style="list-style-type: none"> -Trouble shooting and fault analysis -Familiarization of special maintenance techniques -Special tool and tackles familiarization 	7							
TALCHER THERMAL POWER PROJECT STAGE-III (2X660 MW) EPC PACKAGE	TECHNICAL SPECIFICATIONS SECTION VI, PART-C BID DOC. NO.:CS-4540-001A-2	GENERAL TECHNICAL REQUIREMENTS	PAGE 48 OF 114						

CLAUSE NO.	GENERAL TECHNICAL REQUIREMENTS		एनटीपीसी NTPC
	Zero Liquid Discharge (ZLD)	System Design - Plant water optimization and Scheme to achieve the ZLD - Basic design features - Latest technological trends for ZLD in Thermal Power Plant Plant Visit - Operational feedback - O&M history/problems related to plant	5
	Chlorine Di-Oxide (ClO₂) generation & dosing system	System/Product Design - Basic design features - Theory & principle of operation - Latest technological trends in Chlorine Di-Oxide (ClO ₂) generation & dosing system and design aspects & Selection criteria. Plant Visit - Operational feedback - O&M history/ problems related to ClO ₂ plant Performance Test of generator - Generator capacity performance testing. Operation & Maintenance of Plant -Trouble shooting and fault analysis -Familiarization of special maintenance techniques -Special tool and tackles familiarization	5
	Condensate Polishing Plant (CPU)	System/Product Design - Basic design features including Pre-filters - Theory & principle of operation - Latest technological trends in CPU & Pre-filters and design aspects & Selection criteria. Plant Visit - Operational feedback - O&M history / problems related to CPU plant Visit to Manufacturer's Work -Manufacturing process of pre-filters and major equipment	3
TALCHER THERMAL POWER PROJECT STAGE-III (2X660 MW) EPC PACKAGE	TECHNICAL SPECIFICATIONS SECTION VI, PART-C BID DOC. NO.:CS-4540-001A-2	GENERAL TECHNICAL REQUIREMENTS	PAGE 49 OF 114

CLAUSE NO.	GENERAL TECHNICAL REQUIREMENTS		
		<ul style="list-style-type: none"> -Testing facilities <p>Operation & Maintenance of Plant</p> <ul style="list-style-type: none"> -Trouble shooting and fault analysis -Familiarization of special maintenance techniques -Special tool and tackles familiarization 	
	CW Treatment System	<p>System/Product Design</p> <ul style="list-style-type: none"> - Basic design features - Theory & principle of operation - Latest technological trends and design aspects & Selection criteria. <p>Operation & Maintenance of Plant</p> <ul style="list-style-type: none"> - Operational feedback - O&M history / problems related to plant - Trouble shooting and fault analysis Familiarization of special maintenance techniques - Special tool and tackles familiarization 	3
Note: One week shall constitute of five (5) man days.			
<p>(o) Training for Substation Automation System</p>			
PRODUCT		AREAS OF TRAINING REQUIREMENT	
Substation Automation System		PRODUCT/SYSTEM DESIGN	
		<p>The contractor shall provide training for NTPC personnel comprehensively covering following courses.</p>	
		<ol style="list-style-type: none"> 1 Computer System Hardware 2 Computer System Software 3 Application Software 	
MANDAYS: 60 (Total) inclusive of visit to Manufacturer's site)			
<p>(p) Training on Erection methodologies for all the Sub-packages, System and Equipments associated with the EPC Package, including a visit to power plant construction site.</p>			
<p>The exact details, extent and schedule for training shall be as finalized during detailed engineering and shall be subject to Employer's approval.</p>			
TALCHER THERMAL POWER PROJECT STAGE-III (2X660 MW) EPC PACKAGE	TECHNICAL SPECIFICATIONS SECTION VI, PART-C BID DOC. NO.:CS-4540-001A-2	GENERAL TECHNICAL REQUIREMENTS	PAGE 50 OF 114

CLAUSE NO.	GENERAL TECHNICAL REQUIREMENTS		
28.03.00	<p>The scope of services under training shall also necessarily include training of Employer's Engineering personnel covering entire scope for the package. This shall cover all disciplines viz, Mechanical, Electrical, C&I , QA etc. and shall include all the related areas like Design familiarization, training on product design features and product design software of major equipment and systems, engineering, manufacturing, erection, commissioning, training on operating features of equipment, quality assurance and testing, plant visits and visits to manufacturer's works, exposure to various kinds of problems which may be encountered in fabrication, manufacturing erection, welding etc.</p>		
28.04.00	<p>Contractor shall also arrange for training of Employer's personnel in respect of fire detection and protection systems and other Balance of Plant equipments.</p>		
28.05.00	<p>Contractor shall provide training on application of PAUT (Phased array ultrasonic testing) and TOFD (Time of flight diffraction) techniques for two weeks (at least 80 Hours). The training shall be arranged at least six months prior to the start of erection works of SG & TG works.</p>		
28.06.00	<p>Exact details, extent of training and the training schedule shall be finalized based on the Bidder's proposal within two (2) months from placement of award.</p>		
28.07.00	<p>In all the above cases, the lodging and boarding of the Employer's personnel shall be at the cost of Bidder. The Bidder shall make all necessary arrangements towards the same.</p>		
28.08.00	<p>Take off prices (product wise) should be indicated by the Bidder in the Bid Proposal Sheets. Employer reserves the right to include or exclude these item(s) during placement of Award.</p>		
	<p>Note:</p> <ol style="list-style-type: none"> 1. For training purposes, one (1) man month implies 30 working days (excluding all intervening holidays) per person. 2. The total man months in each area shall be divided into suitable number of modules which shall be discussed and finalized during post award stage. 3. Duration of each module shall not be less than 10 (ten) working days out of which 20 % shall be for plant/manufacturers' works visits and 80% shall be classroom training. 4. A) Location of classroom training for engineering shall be at Design/Engineering office. B) Classroom training for erection/O&M shall be at location of Manufacturers' works. 		
<p>TALCHER THERMAL POWER PROJECT STAGE-III (2X660 MW) EPC PACKAGE</p>	<p>TECHNICAL SPECIFICATIONS SECTION VI, PART-C BID DOC. NO.:CS-4540-001A-2</p>	<p>GENERAL TECHNICAL REQUIREMENTS</p>	<p>PAGE 51 OF 114</p>

CLAUSE NO.	GENERAL TECHNICAL REQUIREMENTS			
28.09.00	TRAINING REQUIRED IN MAN MONTH			
	Area	Engineering (Man months)	Erection (Man months)	O&M (Man months)
	Steam Turbine Generator and its Auxiliaries including electricals	6.5	9.0	23
	Steam Generator and its Auxiliaries including electricals	6.5	9.0	23
	Station C&I (Control and Instrumentation)	3.5	5.5	10
	Ash Handling Plant	2.0	3.0	5.0
	Coal Handling Plant	1.0	1.5	2.5
	UF Membranes, RO Membranes, ZLD, Chlorine Di Oxide (ClO2) generation & dosing system, Condensate Polishing Plant (CPU), CW Treatment System	0.2	0.3	0.5
	Substation Automation System	0.3	0.7	1
	Total	20	29	65
29.00.00	SAFETY ASPECTS DURING CONSTRUCTION AND ERECTION			
	In addition to the requirements given in Erection Conditions of Contract (ECC) the following shall also cover:			
	i) Working platforms should be fenced and shall have means of access.			
	ii) Ladders in accordance with Employer's safety rules for construction and erection shall be used. Rungs shall not be welded on columns. All the stairs shall be provided with handrails immediately after its erection.			
TALCHER THERMAL POWER PROJECT STAGE-III (2X660 MW) EPC PACKAGE	TECHNICAL SPECIFICATIONS SECTION VI, PART-C BID DOC. NO.:CS-4540-001A-2	GENERAL TECHNICAL REQUIREMENTS	PAGE 52 OF 114	



CLAUSE NO.	GENERAL TECHNICAL REQUIREMENTS			
30.00.00	<p>NOISE LEVEL</p> <p>The equivalent 'A' weighted sound pressure level measured at a height of 1.5 m above floor level in elevation and at a distance of one (1) meter horizontally from the nearest surface of any equipment/machine, furnished and installed under these specifications, expressed in decibels to a reference of 0.0002 microbar, shall not exceed 85 dBA except for</p> <ul style="list-style-type: none"> i) Safety valves and associated vent pipes for which it shall not exceed 105 dBA-115 dBA. ii) Regulating drain valves in which case it shall be limited to 90 dBA-115 dBA. iii) Mill noise which will be limited to 85-90 dBA. iv) TG unit in which case it shall not exceed 90 dBA. v) For HP-LP bypass valves and other intermittently operating control valves, the noise level shall be within the limit of 90 dBA. vi) For BFP Motor Noise level shall be within the limit of 90 dBA. 			
31.00.00	<p>PACKAGING, TRANSPORTATION AND STORAGE</p> <p>All the equipments shall be suitably protected, coated, covered or boxed and crated to prevent damage or deterioration during transit, handling and storage at Site till the time of erection. While packing all the materials, the limitation from the point of view of the sizes of railway wagons available in India should be taken account of. The Contractor shall be responsible for any loss or damage during transportation, handling and storage at site due to improper packing and preservation. The Contractor shall ascertain the availability of Railway wagon sizes from the Indian Railways or any other agency concerned in India well before effecting despatch of equipment. Before despatch it shall be ensured that complete processing and manufacturing of the components is carried out at shop, only restricted by transport limitation, in order to ensure that site works like grinding, welding, cutting & preassembly to bare minimum. The Employer's Inspector shall have right to insist for completion of works in shops before despatch of materials for transportation.</p> <p>In addition to above, the contractor shall take all necessary measures for storage of all electronic equipment / systems at site in a dust free Air conditioned space ensuring proper temperature & humidity.</p>			
<p>TALCHER THERMAL POWER PROJECT STAGE-III (2X660 MW) EPC PACKAGE</p>	<p>TECHNICAL SPECIFICATIONS SECTION VI, PART-C BID DOC. NO.:CS-4540-001A-2</p>	<p>GENERAL TECHNICAL REQUIREMENTS</p>	<p>PAGE 53 OF 114</p>	



CLAUSE NO.	GENERAL TECHNICAL REQUIREMENTS																			
32.00.00 32.01.00 33.00.00 33.01.00	<p>ELECTRICAL EQUIPMENTS/ENCLOSURES</p> <p>All electrical equipments and devices, including insulation, heating and ventilation devices shall be designed for ambient temperature and a maximum relative humidity as specified elsewhere in the specifications.</p> <p>INSTRUMENTATION AND CONTROL</p> <p>All instrumentation and control systems/ equipment/ devices/ components, furnished under this contract shall be in accordance with the requirements stated herein, unless otherwise specified in the detailed specifications.</p> <p>All instrument scales and charts shall be calibrated and printed in metric units and shall have linear graduation. The ranges shall be selected to have the normal reading at 75% of full scale.</p> <p>All scales and charts shall be calibrated and printed in Metric Units as follows:</p> <table border="0"> <tr> <td>1. Temperature</td> <td>- Degree centigrade (deg C)</td> </tr> <tr> <td>2. Pressure</td> <td>- Kilograms per square centimetre (Kg/cm²). Pressure instrument shall have the unit suffixed with 'a' to indicate absolute pressure. If nothing is there, that will mean that the indicated pressure is gauge pressure.</td> </tr> <tr> <td>3. Draught</td> <td>- Millimetres of water column (mm wc).</td> </tr> <tr> <td>4. Vacuum</td> <td>- Millimeters of mercury gauge (mm Hg) or water column (mm Wcl).</td> </tr> <tr> <td>5. Flow (Gas)</td> <td>- Tonnes/ hour</td> </tr> <tr> <td>6. Flow (Steam)</td> <td>- Tonnes/ hour</td> </tr> <tr> <td>7. Flow (Liquid)</td> <td>- Tonnes / hour</td> </tr> <tr> <td>8. Flow base</td> <td>- 760 mm Hg. 15 deg.C</td> </tr> <tr> <td>9. Density</td> <td>- Grams per cubic centimetre.</td> </tr> </table>		1. Temperature	- Degree centigrade (deg C)	2. Pressure	- Kilograms per square centimetre (Kg/cm ²). Pressure instrument shall have the unit suffixed with 'a' to indicate absolute pressure. If nothing is there, that will mean that the indicated pressure is gauge pressure.	3. Draught	- Millimetres of water column (mm wc).	4. Vacuum	- Millimeters of mercury gauge (mm Hg) or water column (mm Wcl).	5. Flow (Gas)	- Tonnes/ hour	6. Flow (Steam)	- Tonnes/ hour	7. Flow (Liquid)	- Tonnes / hour	8. Flow base	- 760 mm Hg. 15 deg.C	9. Density	- Grams per cubic centimetre.
1. Temperature	- Degree centigrade (deg C)																			
2. Pressure	- Kilograms per square centimetre (Kg/cm ²). Pressure instrument shall have the unit suffixed with 'a' to indicate absolute pressure. If nothing is there, that will mean that the indicated pressure is gauge pressure.																			
3. Draught	- Millimetres of water column (mm wc).																			
4. Vacuum	- Millimeters of mercury gauge (mm Hg) or water column (mm Wcl).																			
5. Flow (Gas)	- Tonnes/ hour																			
6. Flow (Steam)	- Tonnes/ hour																			
7. Flow (Liquid)	- Tonnes / hour																			
8. Flow base	- 760 mm Hg. 15 deg.C																			
9. Density	- Grams per cubic centimetre.																			
TALCHER THERMAL POWER PROJECT STAGE-III (2X660 MW) EPC PACKAGE	TECHNICAL SPECIFICATIONS SECTION VI, PART-C BID DOC. NO.:CS-4540-001A-2	GENERAL TECHNICAL REQUIREMENTS	PAGE 54 OF 114																	



CLAUSE NO.	GENERAL TECHNICAL REQUIREMENTS			
34.00.00	<p>ELECTRICAL NOISE CONTROL</p> <p>The equipment furnished by the Contractor shall incorporate necessary techniques to eliminate measurement and control problems caused by electrical noise. Areas in Contractor's equipment which are vulnerable to electrical noise shall be hardened to eliminate possible problems. Any additional equipment, services required for effectively eliminating the noise problems shall be included in the proposal. The equipment shall be protected against ESD as per IEC-61000-2. Radio Frequency interference (RFI) and Electro Magnetic Interference (EMI) protection against hardware damage and control system mal-operations/errors shall be provided for all systems as per EN-50082-2 (1995).</p>			
35.00.00	<p>SURGE PROTECTION FOR SOLID STATE EQUIPMENT</p> <p>All solid state systems /equipment shall be able to withstand the electrical noise and surge as encountered in actual service conditions and inherent in a power plant and shall meet the requirements of surge protection as defined in ANSI C37.90.1-1989 on its suitable equivalent class of IEC 254-4. Details of the features incorporated and relevant tests carried out. The test certificates. etc. shall be submitted by the Bidder.</p>			
36.00.00	<p>INSTRUMENT AIR SYSTEM</p> <p>The instrument air supply system as supplied by the Bidder for various pneumatic control & instrumentation devices like pneumatic actuators, power cylinders, E/P converters, piping / tubing etc.</p> <p>Each pneumatic instrument shall have an individual air shut - off valve. The pressure regulating valve shall be equipped with an internal filter, a 50 mm pressure gauge and a built-in filter housing blow down valve.</p>			
37.00.00	<p>TAPPING POINTS FOR MEASUREMENTS</p> <p>Tapping points shall include probes, wherever applicable, for analytical measurements and sampling.</p> <p>For direct temperature measurement of all working media, one stub with internal threading of approved pattern shall be provided along with suitable plug and washer. The Contractor will be intimated about thread standard to be adopted.</p> <p>The following shall be provided on equipment by the Bidder. The standard which is to be adopted, will be intimated to the Contractor.</p> <ul style="list-style-type: none"> i) Temperature test pockets with stub and thermowell ii) Pressure test pockets 			
<p>TALCHER THERMAL POWER PROJECT STAGE-III (2X660 MW) EPC PACKAGE</p>		<p>TECHNICAL SPECIFICATIONS SECTION VI, PART-C BID DOC. NO.:CS-4540-001A-2</p>	<p>GENERAL TECHNICAL REQUIREMENTS</p>	<p>PAGE 55 OF 114</p>

CLAUSE NO.	GENERAL TECHNICAL REQUIREMENTS			
38.00.00	<p>SYSTEM DOCUMENTATION</p> <p>The Bidder shall provide drawings, system overview & description, hardware/software details, technical literature, functional & hardware schemes, bill of material, parts list, interconnection diagrams, data sheets, erection/ installation/ commissioning procedures, instruction/ operating manuals, etc. for each of the C& I system / sub-systems/ equipment supplied under this package. The documentation shall include complete details of the C&I systems/ sub-systems/ equipment to enable review by Employer during detailed engineering stage and to provide information to plant personnel for operation & Maintenance (including quick diagnostics & trouble shooting) of these C&I systems/ sub-systems/ equipment at site. The minimum documentation requirements for C&I systems shall be as stipulated under C&I "Technical Data Sheets" Part of specifications. In addition to this, system documentation for DDCMIS shall include as a minimum to that specified elsewhere in the Technical Specification.</p> <p>The exact format, submission schedule and contents of various documents shall be as finalised during detailed engineering stage.</p>			
38.01.00	Bill of material (instrument list) for all C&I equipment/ devices shall be furnished by the bidder in standard formats as approved by the Employer.			
39.00.00	<p>MAINTENANCE MANUALS OF ELECTRONIC MODULES</p> <p>The Contractor shall have to furnish two (2) sets of all maintenance manual of each and every electronic card/module as employed on the various systems and equipment including peripherals etc., offered by him. The Contractor will also have to furnish the data regarding the expected failure rate of various modules and other system components. Further, the contractor shall furnish a set of operating manuals which should include block diagrams, make, model/type, details wiring and external connection drawings etc. as required to do the testing and maintenance of the electronic modules.</p> <p>Backup & Restoration Procedures of DDCMIS, Station LAN & Advance Process Control shall be provided.</p>			
40.00.00	<p>MAKE IN INDIA REQUIREMENTS</p> <p>a) The bidder shall follow Indian laws, regulations and standards. There shall not be any restriction in terms of compliance to codes & standards of foreign origin only. The compliance to equivalent/better Indian as well as other codes & standards, wherever available, shall also be acceptable.</p> <p>b) The technologies/ products offered shall be environmentally friendly, consuming less energy, and safe, energy efficient, durable and long lasting under the prescribed operational conditions.</p>			
<p>TALCHER THERMAL POWER PROJECT STAGE-III (2X660 MW) EPC PACKAGE</p>	<p>TECHNICAL SPECIFICATIONS SECTION VI, PART-C BID DOC. NO.:CS-4540-001A-2</p>	<p>GENERAL TECHNICAL REQUIREMENTS</p>	<p>PAGE 56 OF 114</p>	



CLAUSE NO.	GENERAL TECHNICAL REQUIREMENTS		
<p>c)</p> <p>d)</p> <p>e)</p> <p>f)</p> <p>g)</p> <p>h)</p> <p>i)</p> <p>j)</p>	<p>The bidder/its sub vendor/supplier shall ensure supply of spares, materials and technological support for the entire life of the project.</p> <p>The bidder shall list out the products and components producing Toxic E-waste and other waste as specified. It shall have an Extended Producers Responsibility (EPR) so that after the completion of the lifecycle, the materials are safely recycled/ disposed of by the contractor and for this, the bidder has to establish recycling/disposal unit as specified.</p> <p>The equipment/ material sourced from foreign companies will be tested in accredited labs in India before acceptance wherever such facilities are available. The testing shall be carried out in accordance with MOP extant order/guidelines.</p> <p>The bidder shall have to furnish a certificate regarding cyber security/safety of the equipment/process to be supplied/services to be rendered as safe to connect.</p> <p>All applicable safety requirements shall be met. Regular safety audit shall be carried out by the manufacturer/ supplier.</p> <p>Wherever required, the foreign supplier shall establish fully functional service centers in India and shall keep spares/material locally for future needs of Employer.</p> <p>To protect the security, integrity and reliability of equipment in this package, it is essential to remove vulnerabilities arising out of the possibility of cyber-attack through malware/ Trojans etc. embedded in imported equipments. This requirement shall apply to any item imported for end use or to be used as a component, or as a part in manufacturing, assembling of any equipment or to be used in this package. Contractor shall comply all the requirements of Order No 25-11/6/2018-PG, dated 02/07/2020 (attached as Appendix-I), issued by Ministry of Power, Government of India and its subsequent amendments/revisions. Contractor shall furnish declaration of compliance of MOP order dated 02/07/2020 requirements with dispatch of equipment/ item. Further, Contractor shall furnish back up testing certificates, whenever Employer asks the same.</p> <p>All equipment/materials/parts/items required in this package which are domestically manufactured with sufficient domestic capacity as identified in Annexure-I of MOP order dated 16/11/2021 including its subsequent revisions (copy attached as Appendix-II) shall necessarily be sourced from the class-I local suppliers only as per the extant provisions of the Public Procurement (Preference to Make in India) Orders issued by DPIIT and MoP.</p> <p>Any violation w.r.t Make in India and minimum local content (MLC) requirements as specified shall be sole responsibility of the Bidder.</p>		
<p>TALCHER THERMAL POWER PROJECT STAGE-III (2X660 MW) EPC PACKAGE</p>	<p>TECHNICAL SPECIFICATIONS SECTION VI, PART-C BID DOC. NO.:CS-4540-001A-2</p>	<p>GENERAL TECHNICAL REQUIREMENTS</p>	<p>PAGE 57 OF 114</p>

CLAUSE NO.	GENERAL TECHNICAL REQUIREMENTS			
	<p style="text-align: right;">Appendix-I</p> <p style="text-align: center;">No.25-11/6/2018-PG Government of India Ministry of Power Shram Shakti Bhawan, Rafi Marg, New Delhi – 110001 Tele Fax: 011-23730264 *****</p> <p style="text-align: right;">Dated 02/07/2020</p> <p style="text-align: center;"><u>ORDER</u></p> <p>Power Supply System is a sensitive and critical infrastructure that supports not only our national defence, vital emergency services including health, disaster response, critical national infrastructure including classified data & communication services, defence installations and manufacturing establishments, logistics services but also the entire economy and the day-to-day life of the citizens of the country. Any danger or threat to Power Supply System can have catastrophic effects and has the potential to cripple the entire country. Therefore, the Power Sector is a strategic and critical sector.</p> <p>The vulnerabilities in the Power Supply System & Network mainly arise out of the possibilities of cyber attacks through malware / Trojans etc. embedded in imported equipment. Hence, to protect the security, integrity and reliability of the strategically important and critical Power Supply System & Network in the country, the following directions are hereby issued :-</p> <p>(1) All equipment, components, and parts imported for use in the Power Supply System and Network shall be tested in the country to check for any kind of embedded malware/trojans/cyber threat and for adherence to Indian Standards.</p> <p>(2) All such testings shall be done in certified laboratories that will be designated by the Ministry of Power (MoP).</p> <p>(3) Any import of equipment/components/parts from "prior reference" countries as specified or by persons owned by, controlled by, or subject to the jurisdiction or the directions of these "prior reference" countries will require prior permission of the Government of India</p> <p>(4) Where the equipment/components/parts are imported from "prior reference" countries, with special permission, the protocol for testing in certified and designated laboratories shall be approved by the Ministry of Power (MoP).</p> <p>This order shall apply to any item imported for end use or to be used as a component, or as a part in manufacturing, assembling of any equipment or to be used in power supply system or any activity directly or indirectly related to power supply system.</p> <p>This issues with the approval of Hon'ble Minister of State for Power and New & Renewable Energy (Independent Charge).</p> <p style="text-align: right;">  (Goutam Ghosh) Director Tel: 011-23716674 </p> <p>To:</p> <ol style="list-style-type: none"> 1. All Ministries/Departments of Government of India (As per list) 2. Secretary (Coordination), Cabinet Secretariat 3. Vice Chairman, NITI Aayog 4. Comptroller and Auditor General of India 5. Chairperson, CEA 6. CMDs of CPSEs/Chairman of DVC & BBMB/MD, EESL/DG, NPTI/DG, CPRI/DG, BEE/ 7. All ASs/JSs/EA, MoP <p>Copy:</p> <ol style="list-style-type: none"> 1. PS to Hon'ble PM, Prime Minister's Office 2. PS to Hon'ble MOS(IC) for Power and NRE 3. Sr. PPS to Secretary(Power) 			
TALCHER THERMAL POWER PROJECT STAGE-III (2X660 MW) EPC PACKAGE	TECHNICAL SPECIFICATIONS SECTION VI, PART-C BID DOC. NO.:CS-4540-001A-2	GENERAL TECHNICAL REQUIREMENTS	PAGE 58 OF 114	

CLAUSE NO.	GENERAL TECHNICAL REQUIREMENTS			
	<p style="text-align: right;">Appendix-II</p> <p style="text-align: center;"> No. A-1/2021-FSC-Part(5) Government of India Ministry of Power Shram Shakti Bhawan, New Delhi Dated: 16th November, 2021 </p> <p style="text-align: center;"><u>ORDER</u></p> <p>Subject: Public Procurement (Preference to Make in India) to provide for Purchase Preference (linked with local content) in respect of Power Sector.</p> <p>Reference: Department for Promotion of Industry and Internal Trade (DPIIT) Notification No. P-45021/2/2017-PP (BE-II) dated 16.09.2020.</p> <p>The Government of India, Department for Promotion of Industry and Internal Trade (DPIIT) issued Public Procurement (Preference to Make in India), Order 2017, for encouraging 'Make in India' and promoting manufacturing and production of goods and services in India with a view to enhancing income and employment. Subsequently, DPIIT vide order No. P-45021/2/2017-PP (BE-II) dated 4th June, 2020 and further vide order dated 16th September, 2020 have issued the revised Public Procurement (Preference to Make in India) Order 2017.</p> <p>2. In light of the Public Procurement (Preference to Make in India) Order 2017, this Ministry had notified purchase preference (linked with local content) for Hydro and Transmission sectors vide Order No. 11/05/2018-Coord dated 20.12.2018, for Thermal sector vide Order dated 28.12.2018 and for Distribution sector vide Order dated 17.03.2020. Further, a combined order dated 04.04.2020 was also issued in supersession of all previous orders to indicate equipment/material/components for which there was sufficient local capacity and competition and also to indicate conditions for including suitably in the tenders to be issued by the procurers. In furtherance of Para 19 of the DPIIT Notification No. P-45021/2/2017-PP(BE-II) dated 04.06.2020, Ministry of Power (MoP) issued a revised comprehensive Order dated 28.07.2020 (Annexure-I amended by order dated 17.09.2020).</p> <p>3. DPIIT Notification No. P-45021/2/2017-PP(BE-II) dated 16.09.2020 has further revised its order dated 04.06.2020. Therefore, in supersession of all the aforementioned orders including order No.10/1/2019-St.Th. (Part-II) dated 20.03.2020 issued by this Ministry, the following has been decided:</p> <ol style="list-style-type: none"> i. For the purpose of this order, the definitions of various terms used in the order, and provisions relating to (i) Eligibility of 'Class-I local supplier'/'Class-II local supplier'/'Non-local suppliers' for different types of procurement, (ii) purchase preference (iii) exemption to small purchases and (iv) margin of purchase preference shall be the same as in DPIIT order dated 16.09.2020, referred to above and extracts of the same is given at Appendix. ii. In procurement of all goods and services or works in respect of which there is sufficient local capacity and local competition as in Annexure-I, only "Class-I local supplier" shall be eligible to bid irrespective of purchase value. "Class-I local supplier" is a supplier or service provider whose goods, services or works offered for procurement meets the Minimum Local Content (MLC) as prescribed in Annexure-I of this order. "Class-II local supplier" means a <p style="text-align: center;"></p>			
TALCHER THERMAL POWER PROJECT STAGE-III (2X660 MW) EPC PACKAGE	TECHNICAL SPECIFICATIONS SECTION VI, PART-C BID DOC. NO.:CS-4540-001A-2	GENERAL TECHNICAL REQUIREMENTS	PAGE 59 OF 114	

CLAUSE NO.	GENERAL TECHNICAL REQUIREMENTS																					
	<p>supplier, as defined by DPIIT in its Order No. P-45021/2/2017-PP (BE-II) dated 16-09-2020.</p> <p>iii. In the procurement of all goods and services or works other than those listed in Annexure-I, only "Class-I local supplier" and "Class-II local supplier" as defined in the order of this Ministry herewith shall be eligible to bid in procurement undertaken by procuring entities, except when Global Tender Enquiry has been issued. In Global tender enquiries, "Non-local suppliers" shall also be eligible to bid along with "Class-I local suppliers" and "Class-II local suppliers". In procurement of all goods, services or works not covered by sub-para 3(ii) above, and with estimated value of purchases less than Rs. 200 crores, in accordance with Rule 161(iv) of GFR, 2017, Global Tender Enquiry(GTE) shall not be issued except with the approval of the competent authority as designated by Department of Expenditure.</p> <p>iv. For the purpose of this order, 'Works' means all works as per Rule 130 of GFR- 2017, and will also include 'turnkey works', Engineering, Procurement and Construction (EPC) contracts and service contracts including System Integrator (SI) contracts.</p> <p>4. The list of items, in respect of which, local capacity with sufficient competition exists as per Annexure-I, will be reviewed at regular intervals with a view to increase number of items in this list and also to increase the MLC for each item, wherever it is less than 100%.</p> <p>5. Purchase preference shall be given to local suppliers in accordance with para 3A of DPIIT Order dated 16.09.2020, and extracts of the same are given at Appendix.</p> <p>6. Further, it has been decided to constitute a committee for independent verification of self-declarations and auditor's / accountant's certificates on random basis and in the case of complaints. The composition of the committee is given below:</p> <table border="1" data-bbox="566 1178 1227 1419"> <tbody> <tr> <td>Member (Planning), Central Electricity Authority (CEA)</td> <td>Chairperson</td> </tr> <tr> <td>Chief Engineer (PSETD), CEA</td> <td>Member</td> </tr> <tr> <td>Chief Engineer (HETD), CEA</td> <td>Member</td> </tr> <tr> <td>Chief Engineer (TETD), CEA</td> <td>Member</td> </tr> <tr> <td>Chief Engineer (DP&R), CEA</td> <td>Member</td> </tr> <tr> <td>As may be co-opted by CEA</td> <td>External Expert</td> </tr> <tr> <td>Chief Engineer (R&D), CEA</td> <td>Convener</td> </tr> </tbody> </table> <p>7. Further, it has also been decided to constitute a committee to examine the grievances in consultation with stakeholders and recommend appropriate actions to the Competent Authority in MoP. The composition of the Committee is given below:</p> <table border="1" data-bbox="646 1541 1157 1612"> <tbody> <tr> <td>Chairperson, CEA</td> <td>Chairperson</td> </tr> <tr> <td>Member (Hydro), CEA</td> <td>Member</td> </tr> </tbody> </table> 			Member (Planning), Central Electricity Authority (CEA)	Chairperson	Chief Engineer (PSETD), CEA	Member	Chief Engineer (HETD), CEA	Member	Chief Engineer (TETD), CEA	Member	Chief Engineer (DP&R), CEA	Member	As may be co-opted by CEA	External Expert	Chief Engineer (R&D), CEA	Convener	Chairperson, CEA	Chairperson	Member (Hydro), CEA	Member	
Member (Planning), Central Electricity Authority (CEA)	Chairperson																					
Chief Engineer (PSETD), CEA	Member																					
Chief Engineer (HETD), CEA	Member																					
Chief Engineer (TETD), CEA	Member																					
Chief Engineer (DP&R), CEA	Member																					
As may be co-opted by CEA	External Expert																					
Chief Engineer (R&D), CEA	Convener																					
Chairperson, CEA	Chairperson																					
Member (Hydro), CEA	Member																					
<p>TALCHER THERMAL POWER PROJECT STAGE-III (2X660 MW) EPC PACKAGE</p>	<p>TECHNICAL SPECIFICATIONS SECTION VI, PART-C BID DOC. NO.:CS-4540-001A-2</p>	<p>GENERAL TECHNICAL REQUIREMENTS</p>	<p>PAGE 60 OF 114</p>																			

CLAUSE NO.	GENERAL TECHNICAL REQUIREMENTS			एनटीपीसी NTPC				
	<table border="1" data-bbox="646 258 1122 317" style="margin-left: auto; margin-right: auto;"> <tr> <td>Member (Power System), CEA</td> <td>Member</td> </tr> <tr> <td>Member (Thermal), CEA</td> <td>Convener</td> </tr> </table> <p data-bbox="513 344 1260 489">8. The complaint fee of Rs. 2 Lakhs or 1% of the value of the local item being procured (subject to maximum of Rs. 5 Lakhs), whichever is higher, shall be paid in the form of Demand Draft, drawn in favour of PAO, CEA, New Delhi. In case the complaint is found to be incorrect, the complaint fee shall be forfeited. In case, the complaint is upheld and found to be substantially correct, the deposited fee of the complainant would be refunded without any interest.</p> <p data-bbox="513 506 1260 552">9. All other conditions, not stipulated in this order, shall be as laid down in the DPIIT's order No. P-45021/2/2017-PP (BE-II) dated 16.09.2020.</p> <p data-bbox="513 569 1260 884">10. This order shall be applicable in respect of the procurement made by all attached or subordinate offices or autonomous bodies under the Government of India including Government Companies as defined in the Companies Act, and /or the States and Local Bodies making procurement under all Central Schemes/ Central Sector Schemes where the Scheme is fully or partially funded by the Government of India. The aforesaid orders shall also be applicable in respect of projects wherein funding of goods, services or works is by Power Finance Corporation (PFC) /Rural Electrification Corporation (REC) and any Financial Institution in which Government of India/ State Government share exists. This order shall be applicable to Tariff Based Competitive Bidding (TBCB) projects also. Procuring entities as defined in the DPIIT's Order dated 16.09.2020 are advised to revise their tender documents to fully comply with the said DPIIT's Order and the subsequent Orders that would be issued in this regard by DPIIT/ this Ministry from time to time.</p> <p data-bbox="513 900 1260 1020">11. All tenders for procurement by Central Government Agencies or the States and Local Bodies, as the case may be, have to be certified for compliance of the Public Procurement (Preference to Make in India) 'PPP-MII' Order by the concerned procurement officer of the Government Organization before uploading the same on the portal.</p> <p data-bbox="513 1037 1260 1205">12. Exemption from meeting the stipulated local content is allowed as per clause 13 and 13A of PPP-MII Order dated 16.09.2020, if the manufacturer declares that the item is manufactured in India under a License from a foreign Manufacturer who holds Intellectual Property Rights (IPRs) and there is Transfer of Technology (ToT) with phasing to increase Minimum Local Content. For such items, if any CPSE under the administration of Ministry of Power requests exemption for any item, it shall be considered by Ministry of Power, on case to case basis.</p> <p data-bbox="513 1222 1260 1323">13. In order to further encourage Make in India initiatives and promote manufacturing and production of goods and services in India, general guidelines as enclosed at Annexure-II may be adopted in an appropriate manner according to the circumstances by the procuring entities in their tendering process.</p> <p data-bbox="513 1339 1260 1486">14. The procurers may specify the higher values of MLC than those specified in this Order in respect of goods, services or works covered in their tenders and award the weightage to the product of higher MLC for which they have to specify the criteria beforehand in their tender. The values given in Annexure-I are the minimum prescribed values for becoming a class-I local supplier for the products indicated therein.</p> <div data-bbox="971 1486 1117 1577" style="text-align: right;">  </div>			Member (Power System), CEA	Member	Member (Thermal), CEA	Convener	
Member (Power System), CEA	Member							
Member (Thermal), CEA	Convener							
TALCHER THERMAL POWER PROJECT STAGE-III (2X660 MW) EPC PACKAGE	TECHNICAL SPECIFICATIONS SECTION VI, PART-C BID DOC. NO.:CS-4540-001A-2	GENERAL TECHNICAL REQUIREMENTS	PAGE 61 OF 114					

CLAUSE NO.	GENERAL TECHNICAL REQUIREMENTS			
	<p>15. This issues with the approval of Hon'ble Minister for Power and New & Renewable Energy.</p> <div style="text-align: right;">  (S. Majumdar) Under Secretary to the Government of India Tele No. 011- 23356938 </div> <p>To:</p> <ol style="list-style-type: none"> 1. Secretary to Government of India (All Ministries/ Departments of Government of India) (As per list) 2. Secretary (Coordination), Cabinet Secretariat 3. CEO, NITI Aayog 4. Chief Secretaries of all States/ UTs 5. Comptroller and Auditor General of India 6. Secretary, DPIIT, Chairman of Standing Committee for implementation of Public Procurement Order, 2017 7. Director General, Bureau of Indian Standards (BIS) 8. Joint Secretary, DPIIT, Member-Convener of Standing Committee for implementation of Public Procurement Order, 2017 9. Chairperson, CEA 10. CMDs of CPSEs, CMD NLC, Chairman of DVC/ BBMB/ EESL, DGs of BEE/ CPRI/ NPTI 11. All Additional Secretaries/ JSs/ EA/ CE, Ministry of Power <p>Copy to: Director (Technical), NIC with a request to publish the Order on the website of Ministry of Power</p>			
<p style="text-align: center;">TALCHER THERMAL POWER PROJECT STAGE-III (2X660 MW) EPC PACKAGE</p>	<p style="text-align: center;">TECHNICAL SPECIFICATIONS SECTION VI, PART-C BID DOC. NO.:CS-4540-001A-2</p>	<p style="text-align: center;">GENERAL TECHNICAL REQUIREMENTS</p>	<p style="text-align: center;">PAGE 62 OF 114</p>	

CLAUSE NO.	GENERAL TECHNICAL REQUIREMENTS			
	<p style="text-align: right;"><u>APPENDIX</u></p> <p><u>Extracts of important provisions contained in DPIIT Order No. P-45021/2/2017-PP (BE-II) dated 16-09-2020</u></p> <p>1. Definitions (Para 2 of DPIIT order):</p> <p>'Local content' means the amount of value added in India which shall, unless otherwise prescribed by the Nodal Ministry, be the total value of the item procured (excluding net domestic indirect taxes) minus the value of imported content in the item (including all customs duties) as a proportion of the total value, in percent.</p> <p>'Class-I local supplier' means a supplier or service provider, whose goods, services or works offered for procurement, meets the minimum local content as prescribed for 'Class-I local supplier' under this Order.</p> <p>'Class-II local supplier' means a supplier or service provider, whose goods, services or works offered for procurement, meets the minimum local content as prescribed for 'Class-II local supplier' but less than that prescribed for "Class-I Local supplier" under this Order.</p> <p>'Non-Local supplier' means a supplier or service provider, whose goods, services or works offered for procurement, has local content less than that prescribed for 'Class-II local supplier' under this Order.</p> <p>'L1' means the lowest tender or lowest bid or the lowest quotation received in a tender, bidding process or other procurement solicitation as adjudged in the evaluation process as per the tender or other procurement solicitation.</p> <p>'Margin of purchase preference' means the maximum extent to which the price quoted by a 'Class-I local supplier' may be above the L1 for the purpose of purchase preference.</p> <p>'Nodal Ministry' means the Ministry or Department identified pursuant to this order in respect of a particular item of goods or services or works.</p> <p>'Procuring entity' means a Ministry or department or attached or subordinate office of, or autonomous body controlled by, the Government of India and includes Government companies as defined in the Companies Act.</p> <p>'Works' means all works as per Rule 130 of GFR- 2017, and will also include 'turnkey works'.</p> <p>2. Eligibility of 'Class-I local supplier'/ 'Class-II local supplier'/ 'Non-local suppliers' for different types of procurement (Para 3 of DPIIT order)</p> <p>(a) In procurement of all goods, services or works in respect of which the Nodal Ministry / Department has communicated that there is sufficient local capacity and local competition, only 'Class-I local supplier', as defined under the Order, shall be eligible to bid irrespective of purchase value.</p> <p>(b) Only 'Class-I local supplier' and 'Class-II local supplier', as defined under the Order, shall be eligible to bid in procurements undertaken by procuring entities, except when Global tender enquiry has been issued. In global tender enquiries, 'Non-local suppliers' shall also be eligible to bid along with 'Class-I local suppliers' and 'Class-II local suppliers'. In procurement of all goods, services or works, not covered by 3(a) above, and with estimated value of purchases less than Rs 200 crores, in accordance with Rule 161(iv) of GFR, 2017 Global tender enquiry shall not</p>			
<p style="text-align: center;">TALCHER THERMAL POWER PROJECT STAGE-III (2X660 MW) EPC PACKAGE</p>	<p style="text-align: center;">TECHNICAL SPECIFICATIONS SECTION VI, PART-C BID DOC. NO.:CS-4540-001A-2</p>	<p style="text-align: center;">GENERAL TECHNICAL REQUIREMENTS</p>	<p style="text-align: center;">PAGE 63 OF 114</p>	

CLAUSE NO.	GENERAL TECHNICAL REQUIREMENTS			
	<p>be issued except with the approval of competent authority as designated by Department of Expenditure.</p> <p>(c) For the purpose of this Order, works includes Engineering, Procurement and Construction (EPC) contracts and services include System Integrator (SI) contracts.</p> <p>3. Purchase Preference (Para 3A of DPIIT order)</p> <p>(a) Subject to the provisions of this Order and to any specific instructions issued by the Nodal Ministry or in pursuance of this Order, purchase preference shall be given to 'Class-I local supplier' in procurements undertaken by procuring entities in the manner specified here under.</p> <p>(b) In the procurements of goods or works, which are covered by para 3(b) of DPIIT Order No. P-45021/2/2017-PP(BE-II) dated 16-09-2021 and which are divisible in nature, the " Class-I local supplier" shall get purchase preference over 'Class-II local supplier' as well as 'Non-local supplier', as per following procedure:</p> <ol style="list-style-type: none"> i. Among all qualified bids, the lowest bid will be termed as L1 If L1 is 'Class-I local supplier', the contract for full quantity will be awarded to L1. ii. If L1 bid is not a 'Class-I local supplier', 50% of the order quantity shall be awarded to L1. Thereafter, the lowest bidder among the 'Class-I local supplier' will be invited to match the L1 price for the remaining 50% quantity subject to the Class-I local supplier's quoted price falling within the margin of purchase preference, and contract for that quantity shall be awarded to such 'Class-I local supplier' subject to matching the L1 price. In case such lowest eligible 'Class-I local supplier' fails to match the L1 price or accepts less than the offered quantity, the next higher 'Class-I local supplier' within the margin of purchase preference shall be invited to match the L1 price for remaining quantity and so on, and contract shall be awarded accordingly. In case some quantity is still left uncovered on Class-I local suppliers, then such balance quantity may also be ordered on the L1 bidder. (c) In the procurements of goods or works, which are covered by para 3(b) of DPIIT Order No. P-45021/2/2017-PP(BE-II) dated 16-09-2021 and which are not divisible in nature, and in procurement of services where the bid is evaluated on price alone, the 'Class-I local supplier' shall get purchase preference over 'Class-II local supplier' as well as 'Non-local supplier', as per following procedure: iii. Among all qualified bids, the lowest bid will be termed as L1. If L1 is 'Class-I local supplier', the contract will be awarded to L1, iv. If L1 is not 'Class-I local supplier', the lowest bidder among the 'Class-I local supplier', will be invited to match the L1 price subject to Class-I local supplier's quoted price falling within the margin of purchase preference, and the contract shall be awarded to such 'Class-I local supplier' subject to matching the L1 price. v. In case such lowest eligible 'Class-I local supplier' fails to match the L1 price, the 'Class-I local supplier' with the next higher bid within the margin of purchase preference shall be invited to match the L1 price and so on and contract shall be awarded accordingly. In case none of the 'Class-I local supplier' within the margin of purchase preference matches the L1 price, the contract may be awarded to the L1 bidder. (d) "Class-II local supplier" will not get purchase preference in any procurement, undertaken by procuring entities. 			
<p>TALCHER THERMAL POWER PROJECT STAGE-III (2X660 MW) EPC PACKAGE</p>	<p>TECHNICAL SPECIFICATIONS SECTION VI, PART-C BID DOC. NO.:CS-4540-001A-2</p>	<p>GENERAL TECHNICAL REQUIREMENTS</p>	<p>PAGE 64 OF 114</p>	

CLAUSE NO.	GENERAL TECHNICAL REQUIREMENTS			
	<p>4. Applicability in tenders where contract is to be awarded to multiple bidders (<i>Para 3B of DPIIT order</i>)- In tenders where contract is to be awarded to multiple bidders subject to matching of L1 rates or otherwise, the 'Class-I local supplier' shall get purchase preference over 'Class-II local supplier' as well as 'Non-local supplier', as per following procedure:</p> <p>a) In case there is sufficient local capacity and competition for the items to be procured, as notified by the Nodal Ministry, only 'Class-I local supplier' shall be eligible to bid. As such, the multiple supplier who would be awarded the contract, should be all and only 'Class-I local suppliers'.</p> <p>b) In other cases, 'Class-II local suppliers' and 'Non-Local suppliers' may also participate in the bidding process along with 'Class-I local supplier' as per provisions of this order.</p> <p>c) If 'Class-I local supplier' qualify for award of contract for at least 50% of the tendered quantity in any tender, the contract may be awarded to all the qualified bidders as per award criteria stipulated in the bid documents. However, in case 'Class-I local supplier' do not qualify for award of the contract for at least 50% of the tendered quantity, purchase preference should be given to the 'Class-I local supplier' over 'Class-II local supplier'/'Non-local suppliers' provided that their quoted rate falls within 20% margin of purchase preference of the highest quoted bidder considered for award of contract so as to ensure that the 'Class-I local suppliers' taken in totality or considered for award of contract for at least 50% of the tendered quantity.</p> <p>d) First purchase preference has to be given to the lowest quoting 'Class-I local supplier', whose quoted rates fall within 20% margin of purchase preference subject to its meeting the prescribed criteria for award of contract as also the constraints of maximum quantity that can be sourced from any single supplier. If the lowest quoting 'Class-I local supplier', does not qualify for purchase preference because of aforesaid constraints or does not accept the offered quantity, an opportunity may be given to next higher 'Class-I local supplier' falling within 20% margin of purchase preference, and so on.</p> <p>e) To avoid any ambiguity during bid evaluation process, the procuring entities may stipulate its own tender specific criteria for award of contract amongst different bidders including the procedure for purchase preference to 'Class-I local supplier' within the broad policy guidelines stipulate in sub-paras above.</p> <p>5. Exemption of small purchases (<i>Para 4 in DPIIT order</i>): Procurements where the estimated value to be procured is less than Rs. 5 lakhs shall be exempt from this Order. However, it shall be ensured by procuring entities that procurement is not split for the purpose of avoiding the provisions of this Order.</p> <p>6. Minimum Local Content (<i>Para 5 in DPIIT order</i>): The 'local content' requirement to categorize a supplier as 'Class-I local supplier' is minimum 50%. For 'Class-II local supplier', the local content requirement is minimum 20%. Nodal Ministry/Department may prescribe only a higher percentage of minimum local content requirement to categorize a supplier as 'Class-I local supplier'/'Class-II local supplier'. For the item for which Nodal Ministry/Department has not prescribed higher minimum local content notification under the order, it shall be 50% and 20% for 'Class-I local supplier'/'Class-II local supplier' respectively.</p>			
<p>TALCHER THERMAL POWER PROJECT STAGE-III (2X660 MW) EPC PACKAGE</p>	<p>TECHNICAL SPECIFICATIONS SECTION VI, PART-C BID DOC. NO.:CS-4540-001A-2</p>	<p>GENERAL TECHNICAL REQUIREMENTS</p>	<p>PAGE 65 OF 114</p>	

CLAUSE NO.	GENERAL TECHNICAL REQUIREMENTS			
	<p>7. Vide DPIIT OM No. P-45021/102/2019-BE-IIPart(1) (E-50310) dated 4.03.2021 services such as transportation, insurance, installation, commissioning, training and after sales service support like AMC/CMC etc. shall not be considered as local value addition. Bidders offering imported products will fall under the category of Non- local suppliers. They can't claim themselves as Class-I local suppliers/Class-II local suppliers by claiming the services such as transportation, insurance, installation, commissioning, training and after sales service support like AMC/CMC etc. as local value addition.</p> <p>8. Margin of Purchase Preference (Para 6 of DPIIT order): The margin of purchase preference shall be 20%.</p> <p>9. Specifications in Tenders and other procurement solicitations (Para 10 of DPIIT order):</p> <p>a. Every procuring entity shall ensure that the eligibility conditions in respect of previous experience fixed in any tender or solicitation do not require proof of supply in other countries or proof of exports.</p> <p>b. Procuring entities shall endeavour to see that eligibility conditions, including on matters like turnover, production capability and financial strength do not result in unreasonable exclusion of 'Class-I local supplier'/ 'Class-II local supplier' who would otherwise be eligible, beyond what is essential for ensuring quality or creditworthiness of the supplier.</p> <p>c. Procuring entities shall, within 2 months of the issue of this Order review all existing eligibility norms and conditions with reference to sub-paragraphs 'a' and 'b' above.</p> <p>d. Reciprocity Clause:</p> <p>i. When a Nodal Ministry/Department identifies that Indian suppliers of an item are not allowed to participate and/ or compete in procurement by any foreign government, due to restrictive tender conditions which have direct or indirect effect of barring Indian companies such as registration in the procuring country, execution of projects of specific value in the procuring country etc. it shall provide such details to all its procuring entities including CMDs/CEOs of PSEs/PSUs, State Governments and other procurement agencies under their administrative control and GeM for appropriate reciprocal action.</p> <p>ii. Entities of countries which have been identified by the nodal Ministry/Department as not allowing Indian companies to participate in their Government procurement for any item related to that nodal Ministry shall not be allowed to participate in Government procurement in India for all the items related to that nodal Ministry/Department, except for the list of items published by the Ministry/Department permitting their participation.</p> <p>iii. The stipulation in (ii) above shall be part of all tenders invited by the Central Government procuring entities stated in (i) above. All purchase on GeM shall also necessarily have the above provisions for items identified by nodal Ministry/Department.</p> <p>iv. State Governments should be encouraged to incorporate similar provisions in their respective tenders.</p> <p>v. The term 'entity' of a country shall have the same meaning as under the FDI Policy of DPIIT as amended from time to time.</p> <p>e. Specifying foreign certification/ unreasonable technical specifications/ brands/ models in the bid document is restrictive and discriminatory practice against local</p>			
<p>TALCHER THERMAL POWER PROJECT STAGE-III (2X660 MW) EPC PACKAGE</p>	<p>TECHNICAL SPECIFICATIONS SECTION VI, PART-C BID DOC. NO.:CS-4540-001A-2</p>	<p>GENERAL TECHNICAL REQUIREMENTS</p>	<p>PAGE 66 OF 114</p>	

CLAUSE NO.	GENERAL TECHNICAL REQUIREMENTS			
	<p>suppliers. If foreign certification is required to be stipulated because of non-availability of Indian Standards and/ or for any other reason, the same shall be done only after written approval of Secretary of Department concerned or any other authority having been designated such power by the Secretary of the Department concerned.</p> <p>f. "All administrative Ministries/Departments whose procurement exceeds Rs. 1000 Crore per annum shall notify/ update their procurement projections every year, including those of PSEs/PSUs, for the next 5 years on their respective website."</p>			
<p>TALCHER THERMAL POWER PROJECT STAGE-III (2X660 MW) EPC PACKAGE</p>	<p>TECHNICAL SPECIFICATIONS SECTION VI, PART-C BID DOC. NO.:CS-4540-001A-2</p>	<p>GENERAL TECHNICAL REQUIREMENTS</p>	<p>PAGE 67 OF 114</p>	

CLAUSE NO.	GENERAL TECHNICAL REQUIREMENTS		
	Annexure-I		
	Sl. No.	Electrical Equipment for Generation, Transmission and Distribution sectors with sufficient local capacity and competition	Class-I Local Supplier (Minimum Local Content (%))
	(A) Common items for Transmission, Distribution and Generation Sector		
	1	Power Transformers (up to 765 kV, including Generator transformers)	60
	2	Instrument Transformer (up to 765 kV)	60
	3	Transformer Oil Dry Out System (TODOS)	60
	4	Reactors up to 765 kV	60
	5	Oil Impregnated Bushing (up to 400 kV)	60
	6	Resin Insulated Paper (RIP) bushings (up to 145 kV)	50
	7	Circuit Breakers (up to 765 kV AC - Alternating Current)	60
	8	Disconnectors/Isolators (up to 765 kV AC)	60
	9	Wave trap (up to 765 kV AC)	60
	10	Oil Filled Distribution Transformers up to & Including 33 kV [Cold Rolled Grain Oriented (CRGO)/Amorphous, Aluminium/Copper wound]	60
	11	Dry Type Distribution Transformer upto and including 33 kV (CRGO/Amorphous, Aluminium/Copper wound)	60
	12	Conventional Conductor	60
	13	Accessories for Conventional conductors	60
	14	High Temperature/High Temperature Low Sag (HTLS) conductors (such as Composite core, GAP, ACSS, INVAR, AL59) and Accessories	60
	15	Optical ground wire (OPGW) – all designs	60
	16	Fiber Optic Terminal Equipment (FOTE) for OPGW	50
	17	OPGW related Hardware and Accessories	60
	18	Remote Terminal Unit (RTU)	50
	19	Power Cables and accessories up to 33 kV	60
	20	Control cables including accessories	60
	21	XLPE Cables up to 220 kV	60
	22	Substation Structures	60
	23	Transmission Line Towers	60
	24	Porcelain (Disc/Long Rod) Insulators	60
	25	Bus Post Insulators (Porcelain)	60
	26	Porcelain Disc Insulators with Room Temperature Vulcanisation (RTV) coating	50
	27	Porcelain Longrod Insulators with Room Temperature Vulcanisation (RTV) coating	50
	28	Hardware Fittings for Porcelain Insulators	60
	29	Composite/Polymeric Long Rod Insulators	60
	30	Hardware Fittings for Polymer Insulators	60
	31	Bird Flight Diverter (BFD)	60
	32	Power Line Carrier Communication (PLCC) System (up to 800 kV)	60
	33	Gas Insulated Switchgear (up to 400 kV AC)	60
	34	Gas Insulated Switchgear (above 400 kV AC)	50
	35	Surge/Lightning Arrester (up to 765 kV AC)	60
	36	Power Capacitors	60
	37	Packaged Sub-station (6.6 kV to 33 kV)	60
	38	Ring Main Unit (RMU) (up to 33 kV)	60
	39	Medium Voltage (MV) GIS Panels (up to 33 kV)	60
	40	Automation and Control System/Supervisory Control and data Acquisition (SCADA) System in Power System	50
	41	Control and Relay Panel (including Digital/Numerical Relays)	50
	42	Electrical Motors 0.37 kW to 1 MW	60
	43	Energy Meters excluding smart meters	50
	44	Control & power cables and Accessories (up to 1.1 kV)	60
	45	Diesel Generating (DG) set	60
TALCHER THERMAL POWER PROJECT STAGE-III (2X660 MW) EPC PACKAGE		TECHNICAL SPECIFICATIONS SECTION VI, PART-C BID DOC. NO.:CS-4540-001A-2	GENERAL TECHNICAL REQUIREMENTS
			PAGE 68 OF 114

CLAUSE NO.

GENERAL TECHNICAL REQUIREMENTS



Sl. No.	Electrical Equipment for Generation, Transmission and Distribution sectors with sufficient local capacity and competition	Class-I Local Supplier (Minimum Local Content (%))
46	DC system (DC Battery & Battery Charger)	60
47	AC & DC Distribution Board	60
48	Indoor Air Insulated Switchgear (AIS) upto 33 kV	60
49	Poles (PCC, PSCC, Rolled Steel Joist, Rail Pole, Spun, Steel Tubular)	60
50	Material for Grounding/earthing system	60
51	Illumination system	60
52	Overhead Fault Sensing Indicator (FSI)	50
53	Power Quality Meters	50
54	Auxiliary Relays	50
55	Load Break Switch	50
(B) Hydro Sector		
56	Hydro Turbine & Associated equipment	
	a) Francis Turbine	60
	b) Kaplan Turbine	60
	c) Pelton Turbine	50
57	Main Inlet Valve & Associated Equipment	60
58	Penstock Protection Valve and Associated Equipment	60
59	Governing system & Accessories	60
60	Generator for Hydro Project & Associated Equipment	60
61	Static Excitation System	60
62	Workshop Equipment	60
63	Cooling Water System	60
64	Compressed Air System	60
65	Drainage/Dewatering System	60
66	Fire Protection System	60
67	Heating, Ventilation & Air Conditioning System (HVAC)	60
68	Oil Handling System	60
69	Mechanical Balance of Plant (BOP) Items	60
(C) Thermal Sector		
Boiler Auxiliaries		
70	Air Pre-Heater	60
71	Steam Coil Air Pre Heater (SCAPH)	60
72	Steam soot blowers [wall blowers & Long Retractable Soot Blower (LRSB)]	60
73	Auxiliary Steam Pressure Reducing & Desuperheating (PRDS)	60
74	Fuel oil system	60
75	Seal air Fan	60
76	Ducts and dampers	60
77	Duct expansion joints	60
78	Blowdown tanks	60
79	Coal burners and oil burners	60
80	Coal mills	60
81	Gear Box of Coal Mill	50
82	Coal feeders	60
83	Primary Air Fans	60
84	Forced Draft Fans	60
85	Induced Draft Fans	60
86	Forced Draft (FD)/Induced Draft (ID)/ Primary Air (PA) Fan Servo Motor Assembly	50
87	Tubes (Carbon Steel)	50
88	Steam pipes (Carbon Steel)	50
89	Steam drum	50
90	Separator	50
91	Selective Catalytic Reduction (SCR)	50

TALCHER THERMAL POWER PROJECT
STAGE-III (2X660 MW)
EPC PACKAGE

TECHNICAL SPECIFICATIONS
SECTION VI, PART-C
BID DOC. NO.:CS-4540-001A-2

GENERAL TECHNICAL
REQUIREMENTS

PAGE
69 OF 114

CLAUSE NO.	GENERAL TECHNICAL REQUIREMENTS		
	Sl. No.	Electrical Equipment for Generation, Transmission and Distribution sectors with sufficient local capacity and competition	Class-I Local Supplier (Minimum Local Content (%))
		Electro-Static Precipitators (ESPs)	
	92	Casing	60
	93	Electrodes	60
	94	Rapping System	60
	95	Hopper Heaters	60
	96	Transformer Rectifiers	60
	97	Insulators	60
		Turbine & Auxiliaries	
	98	Turbine (High Pressure/Intermediate Pressure/Low Pressure)	50
	99	Condensate Extraction Pumps	60
	100	Condenser On line Tube Cleaning System (COLTC)	60
	101	Debris filters	60
	102	Deaerator	60
	103	Drain Cooler and Flash Tank	60
	104	ECW Pump	50
	105	Plate Heat Exchanger	50
	106	Self-cleaning filters	50
	107	Condensate Polishing Units (CPUs)	60
	108	Chemical Dosing System	60
	109	Oil Filter	60
	110	Gland Steam Condenser	60
	111	Oil Purifying Centrifuge	50
	112	Water Cooled Condenser	50
	113	Boiler Feed Pumps (BFPs)	50
		Generator and Auxiliaries	
	114	Generator (including Seal Oil System, Hydrogen Cooling System, Stator water cooling system)	60
		Electrical Works	
	115	Control and metering equipment	60
		Control & Instrumentation System (C&I System)	
	116	Thermocouples	50
	117	Measuring instruments [Resistance Temperature Detectors (RTDs)], Local gauges	50
	118	Actuators (Pneumatic and conventional electric)	50
	119	Interplant Communication/ Public Address (PA) system except IP based	50
		Coal Handling Plant	
	120	Conveyors	60
	121	Wagon Tippler	60
	122	Side Arm Charger	60
	123	Paddle feeder	60
	124	Crushers & Screens	60
	125	Dust suppression (dry fog & plain water) system	60
	126	Air Compressors	50
	127	Magnetic separators & metal detectors	60
	128	Coal Sampling System	60
	129	Stacker cum reclaimers	60
	130	Belt weighing & monitoring system.	60
	131	Wheel & axle assembly (without bearings) for Bottom Opening Bottom Release (BOBR) Wagons	60
		Ash Handling System	
	132	Clinker grinder	60
	133	Water jet ejectors	60
	134	Scrapper chain conveyor	60
	135	Dry fly ash vacuum extraction system	60
	136	Pressure pneumatic conveying system	60

TALCHER THERMAL POWER PROJECT
STAGE-III (2X660 MW)
EPC PACKAGE

TECHNICAL SPECIFICATIONS
SECTION VI, PART-C
BID DOC. NO.:CS-4540-001A-2

GENERAL TECHNICAL
REQUIREMENTS

PAGE
70 OF 114

CLAUSE NO.	GENERAL TECHNICAL REQUIREMENTS		
	Sl. No.	Electrical Equipment for Generation, Transmission and Distribution sectors with sufficient local capacity and competition	Class-I Local Supplier (Minimum Local Content (%))
	137	Ash water & ash slurry pumps	60
	138	Compressors, air dryers & air receivers	50
	139	Ash water recovery system	60
		Raw Water Intake & Supply System	
	140	Travelling water screens	60
	141	Raw water supply pumps	60
	142	Valves, RE joints etc.	60
		Water Treatment System and Effluent Treatment System	
	143	Clarification plant	60
	144	Filtration plant	60
	145	Ultra filtration plant	50
	146	Reverse Osmosis (RO) plant and its membrane	55
	147	De-Mineralised water plant (DM Plant)	60
	148	Chlorination plant	60
	149	Chemical dosing system	60
	150	Effluent Treatment Plant	60
		Circulating Water (CW) & Auxiliary Circulating Water (ACW) System	
	151	CW & ACW Pumps	60
	152	Butter Fly (BF) valves, Non-return Valves (NRVs) etc.	60
	153	Rubber Expansion (RE) joints	60
	154	Air release valves	60
		Cooling Towers (NDCT/ IDCT)-Natural-Draft and Induced Draft Cooling Tower	
	155	Water Distribution System	60
	156	Spray nozzles	60
	157	Packing	60
	158	Drift eliminators	60
	159	Cooling Tower (CT) Fans (for Induced Draft Cooling Towers IDCT)	60
	160	Gear boxes, shafts & motors (for IDCT)	60
		Air Conditioning & Ventilation System	
	161	Split & window air conditioners	60
	162	Chilling/ condensing unit [upto 500 ton of refrigeration(TR)]	55
	163	Air Handling Unit (AHU) and Fresh air unit	60
	164	Cooling Towers	60
	165	Air Washing Units (AWUs), axial fans, roof extractors	60
	166	Ducts, louvers & dampers	60
		Flue Gas Desulphurization (FGD)	
	167	Spray Nozzles,	50
	168	Spray header	50
	169	Oxidation Blowers	50
	170	Limestone wet Ball Mill	50
	171	Slurry Handling Pumps for FGD system	50
	172	Booster Fans for FGD system	50
	173	Carbon Steel Ducts and Dampers for FGD	60
	174	Storage Tanks and Silos	60
	175	Process Water Pump for FGD system	50
		(D) Other Common Items	
		Fire protection and detection system	
	176	Motor driven fire water pumps	60
	177	Diesel engine driven fire water pumps	60
	178	Hydrant system for the power plant.	60
	179	High velocity water spray system	60
	180	Medium velocity water spray system	60
	181	Foam protection system	60
	182	Inert gas flooding system	60

CLAUSE NO.

GENERAL TECHNICAL REQUIREMENTS



Sl. No.	Electrical Equipment for Generation, Transmission and Distribution sectors with sufficient local capacity and competition	Class-I Local Supplier (Minimum Local Content (%))
183	Fire tenders	60
184	Portable fire-extinguishers	60
185	Cranes, EOT cranes, gantry crane & chain pulley blocks etc.	60
186	Elevator	60

(E) Minimum Local Content percentages in Engineering, Procurement & Construction (EPC) / Turnkey project

In case the contract is awarded through the EPC route, the contractor should comply with the requirement of MLC for individual items as listed in Annexure-I and should purchase these items only from Class-I Local supplier. In addition, MLC for complete EPC project may also be prescribed as below:

	(1) Package Based Works	Minimum Local Content (%)
1	Boiler	60
2	TG System (Water Cooled Condenser)	60
3	Ash Handling Plant	60
4	Coal Handling Plant	60
5	Electro-static Precipitator (ESP)	60
6	Circulating Water (CW) System	60
7	Cooling Tower	60
8	Water Treatment System	60
9	Air Conditioning System (below 500TR)	60
10	Flue Gas Desulphurisation (FGD) System	60
11	Station Control & Instrumentation (C&I)	50
12	Hydro Power Projects (Electro-Mechanical Works)	60
	Gas based generation	
	Overall Gas Turbine Package (on finished Product basis)	
13	< 44 MW	60
14	44 –145 MW	50
	Overall Combined Cycle Gas Turbine (CCGT) Package (on finished Product basis)	
15	< 44 MW	60
16	44 – 145 MW	60
17	> 150 MW	60
	(2) Project as a whole	
1	Works and service contracts in Power Sector	60
2	Transmission Line with Conventional conductors (ACSR, AAAC, AL-59 etc.)	60
3	Transmission Line with High temperature Low Sag (HTLS) conductors	60
4	HVAC Substation Air Insulated (AIS)	60
5	HVAC Substation Gas Insulated (GIS)	60
6	HVDC Substation	60
7	Distribution Sector	60

TALCHER THERMAL POWER PROJECT
STAGE-III (2X660 MW)
EPC PACKAGE

TECHNICAL SPECIFICATIONS
SECTION VI, PART-C
BID DOC. NO.:CS-4540-001A-2

GENERAL TECHNICAL
REQUIREMENTS

PAGE
72 OF 114

CLAUSE NO.	GENERAL TECHNICAL REQUIREMENTS			
	<p style="text-align: right;">Annexure-II</p> <p>General guidelines to be adopted selectively in an appropriate manner by the procuring entities in their tender documents.</p> <ol style="list-style-type: none"> 1. The bidder shall have to be an entity registered in India in accordance with law. 2. The bids shall be in the language as prescribed by the tenderer/procurer. 3. The bids shall be in Indian Rupees (INR) (in respect of local content only). 4. Indian subsidiaries of foreign bidders shall have to meet the qualifying criteria in terms of capability, competency, financial position, past performance etc. 5. The bidder shall follow Indian laws, regulations and standards. 6. To be eligible for participation in the bid, foreign bidders shall compulsorily set up their manufacturing units on a long term basis in India as may be specified by the tenderer/ procurer. 7. Similar or better technology than the technology offered in respect of material, equipment and process involved shall be transferred to India. Along with the transfer of technology, adequate training in the respective field shall also be provided. 8. Country of origin of the equipment/material shall be provided in the bid. 9. For supply of equipment / material from the country of origin other than India, the bidder shall submit performance certificate in support of satisfactory operation in India or a country other than the country of origin having climatic and operational conditions including ambient temperature similar to that of India for more than _____ years (to be specified by the procurer). 10. The technologies/ products offered shall be environmental friendly, consuming less energy, safe, energy efficient, durable and long lasting under the prescribed operational conditions. 11. The supplier shall ensure supply of spares, materials and technological support for the entire life of the project. 12. The manufacturers/ supplier shall list out the products and components producing Toxic E-waste and other waste as may be specified. It shall have an Extended Producers Responsibility (EPR) so that after the completion of the lifecycle, the materials are safely recycled / disposed of by the Manufacturer/ supplier and for this, the Manufacturer/supplier along with procurer has to establish recycling / disposal unit or as may be specified. 13. Minimum Local Content requirement for goods, services or works shall be in accordance with the conditions laid down in respective Order(s) of the sectors on Public Procurement (Preference to Make in India) to provide for purchase preference (linked with local content). 			
<p style="text-align: center;">TALCHER THERMAL POWER PROJECT STAGE-III (2X660 MW) EPC PACKAGE</p>	<p style="text-align: center;">TECHNICAL SPECIFICATIONS SECTION VI, PART-C BID DOC. NO.:CS-4540-001A-2</p>	<p style="text-align: center;">GENERAL TECHNICAL REQUIREMENTS</p>	<p style="text-align: center;">PAGE 73 OF 114</p>	

CLAUSE NO.	GENERAL TECHNICAL REQUIREMENTS			
	<p>14. The equipment/ material sourced from foreign companies may be tested in accredited labs in India before acceptance wherever such facilities are available.</p> <p>15. The Tender fee and the Bank Guarantee (BG) shall be in Indian Rupees only.</p> <p>16. The bidder shall have to furnish a certificate regarding cyber security/safety of the equipment/process to be supplied/services to be rendered as safe to connect.</p> <p>17. Applicable safety requirements shall be met. Regular safety audit shall be carried out by the manufacturer/ supplier.</p> <p>18. Statutory laws/regulations including the labour and environmental laws shall be strictly complied with during supply, storage, erection, commissioning and operation process. A regular compliance report shall be submitted to the procurer/appropriate Authorities.</p> <p>19. Formation of new joint venture in India shall be permitted only with the Indian companies.</p> <p>20. Tendering by the agent shall not be accepted.</p> <p>21. In case local testing is not considered necessary by the procurer, the original test report in the language prescribed by the procurer may be accepted. The translated test report shall not be accepted unless it is notarised.</p> <p>22. Certification/compliance as per the Indian Standards/ International Standards/ Indian Regulations/ specified Standards shall be mandatory, where ever applicable.</p> <p>23. Quality assurance of the product shall be carried out by the procurer or an independent third party agency appointed by the procurer. Manufacturing Quality Plan as approved by the procurer shall be followed by the manufacturer/supplier.</p> <p>24. Wherever required by the procurer, foreign supplier shall establish fully functional service centers in India and shall keep spares/material locally for future needs of utilities.</p> <p>25. Arbitration proceedings shall be instituted in India only and all disputes shall be settled as per applicable Indian Laws.</p>			
<p>TALCHER THERMAL POWER PROJECT STAGE-III (2X660 MW) EPC PACKAGE</p>	<p>TECHNICAL SPECIFICATIONS SECTION VI, PART-C BID DOC. NO.:CS-4540-001A-2</p>	<p>GENERAL TECHNICAL REQUIREMENTS</p>	<p>PAGE 74 OF 114</p>	

CLAUSE NO.	GENERAL TECHNICAL REQUIREMENTS		
	LIST OF CODES AND STANDARDS		
	Indian Standards	Title	International and Internationally recognised standards
	IS:277	Galvanised steel sheets (plain or corrugated)	
	IS:655	Specification for metal air duct	
	IS:800	Code of practice for use of structural steel in general building construction	BS 449:1969 BS 5950 ASA A57, 1-1952
	IS:807	Code of practice for design, manufacture, erection and testing (Structural portion) of cranes and hoists 6588 (Issued by Standards Association of Australia). DIN 120:1936 (Sheet 1) DIN 120:1936 (Sheet 2) 327 part-I, 1951 BS 466 part-II, 1960 BS 644:1960 BS 1757:1951 BS 2573:part-I:1960	Draft Revision of A.S. NO. CS.2 SAA Crane and Hoist code Doc:No. BU/4 Rev
	IS:875	Code of practice for design loads (other than earthquake) for buildings and structures Leading standards (issued by Canadian Standard) DIN-1055-1955 (Issued by ASA)	National Building code of Canada (1953)-Part-IV Design section 4.1
TALCHER THERMAL POWER PROJECT STAGE-III (2X660 MW) EPC PACKAGE	TECHNICAL SPECIFICATIONS SECTION VI, PART-C BID DOC. NO.:CS-4540-001A-2	GENERAL TECHNICAL REQUIREMENTS	PAGE 75 OF 114

CLAUSE NO.	GENERAL TECHNICAL REQUIREMENTS			
IS:1239 Part-I	Mild steel tubes	(ISO/R 65-1957) (ISO/R-64-1958) (ISO/R-65-1958) (BS 1387 : 1957)		
IS:1239 Part-II	Mild steel tubulars and other wrought steel pipe fittings	BS 1387 : 1967 BS 1387 :1967 BS 1740 :1965		
IS:2825	Code for unfired vessels			
IS:1520	Horizontal centrifugal pumps for clear cold and fresh water			
IS:1600	Code for practice for performance of constant speed IC Engines for general purpose			
IS:1601	Specification for perform- ance of constant speed IC Engines for general Purpose			
IS:1893	Criteria for earthquake resistant design of structures			
IS1978-1971	Line Pipe April 1969.		API Standards 5L	
IS:2254-1970	Dimensions of vertical shaft motor for pumps		IEC Pub 72-1 part I NEMA Pub MG 1 1954	
IS:2266	Steel wire ropes for general engineering purposes		BS :302 : 1968	
IS:2312	Propellant type Ventilation fans			
IS:2365	Steel wire suspension ropes for lifts and hoists		BS : 1957	
TALCHER THERMAL POWER PROJECT STAGE-III (2X660 MW) EPC PACKAGE	TECHNICAL SPECIFICATIONS SECTION VI, PART-C BID DOC. NO.:CS-4540-001A-2	GENERAL TECHNICAL REQUIREMENTS	PAGE 76 OF 114	

CLAUSE NO.	GENERAL TECHNICAL REQUIREMENTS		
	IS:3346	Method for the determination of thermal conductivity of thermal insulation materials (two slab guarded hot plate method)	DIN 52612 (Deutscher Normenausschuss) ASTM C 163-1964 (American Society of Testing and materials) ASTM C 167-1974 ASTM C 177-1963
	IS:3354	Outline dimensions for electric lifts.	
	IS:3401	Silica gel	
	IS:3588	Specification for electrical axial flow fans	
	IS:3589	Electrically welded steel pipes for water, gas and sewage (200mm to 2000 mm Nominal Diameter)	
	IS:3677	Unbonded rock and slag wool for thermal insulation	
	IS:3815	Point hook with shank for general engineering purposes	BS 482 - 1968 Doc.:67/3 1284 (Revision of BS 2903) (Issued BS)
	IS:3895	Specification for monocrystalline semiconductor rectifier cells and stacks	
	IS:3963	Roof extractor unit	
	IS:3975	Mild steel wires, strips and tapes for armouring cables	
	IS:4503	Shell and tube type heat Exchanger	
TALCHER THERMAL POWER PROJECT STAGE-III (2X660 MW) EPC PACKAGE	TECHNICAL SPECIFICATIONS SECTION VI, PART-C BID DOC. NO.:CS-4540-001A-2	GENERAL TECHNICAL REQUIREMENTS	PAGE 77 OF 114

CLAUSE NO.	GENERAL TECHNICAL REQUIREMENTS		
IS:4540	Specification for monory-stallines rectifire assembly equipment		
IS:4671	Expanded polystyrene for thermal insulation purpose		
IS:4736	Hot dip zinc coating on steel tubes		
IS:4894	Centrifugal fans		
IS:5456	Code of practice for testing of positive displacement type air compressors and exhauster (For Test Tolerance Only)		
IS:5749	Forged ramshorn hooks	Entwurf DIN 15402 Blett 1 Entwurf DIN 15402 BS 3017-1958	
IS:6392	Steel pipe flanges	BS 4504 : 1969	
IS:6524 Part-I	Code of practice for design of tower cranes Static and rail mounted	BS 2799 : 1956	
IS:7098	Cross linked Polyethylene insulated PVC sheathed cables	Standard No. 1 to IPCEA (USA) Pub. No. 5-66-524	
IS:7373	Specification for wrought aluminium and aluminium sheet and strips		
IS:7938	Air receivers for compressed air installation		
ISO:1217	Displacement compressor-Acceptance test		
ASHRAE-33 and air heating coils.	Methods of testing for rating of forced circulation air cooling		
ASHRAE-52-76 particle matter.	Air cleaning device used in general ventilation for removing		
TALCHER THERMAL POWER PROJECT STAGE-III (2X660 MW) EPC PACKAGE	TECHNICAL SPECIFICATIONS SECTION VI, PART-C BID DOC. NO.:CS-4540-001A-2	GENERAL TECHNICAL REQUIREMENTS	PAGE 78 OF 114

CLAUSE NO.	GENERAL TECHNICAL REQUIREMENTS		
	<p>ASHRAE-22-72 Method of testing for rating of water cooled refrigerant condensers.</p> <p>ASHRAE 23-67 Methods of testing for rating of positive displacement refrigerant compressors.</p> <p>ARI-450-6 Standard for water cooled refrigerant condensers.</p> <p>ARI-550 Standard for centrifugal water chilling packages.</p> <p>ARI-410 Standard for forced circulation air cooling and air heating coils</p> <p>ARI-430/435 Central station AHU/Application of Central Station AHU BS:848 Fans (Part-1,2)</p> <p>BS:400 Low carbon steel cylinders for the storage & transport of permanent gases.</p> <p>BS:401 Low carbon steel cylinders for the storage & transport of liquified gases.</p> <p>CTI Code Acceptance test code for Water Cooling Tower. ACT-105</p> <p>ANSI-31.5 Refrigerant piping</p> <p>ASME-PTC- Atmospheric Water Cooling Equipment 23-1958</p> <p>AMCA A-21C Test Code for air moving devices</p> <p>API:618 Reciprocating Compressor for general refinery services.</p> <p>HYDRAULIC INSTITUTE STANDARDS.</p> <p>HYDRANT SYSTEM MANUALS OF TAC.</p> <p>TAC MANUALS OF SPRAY SYSTEM</p> <p>NFPA USA/ NSC UK/ UL USA/ FM USA STANDARDS.</p> <p>INDIAN EXPLOSIVES ACT.</p> <p>INDIAN FACTORIES ACT.</p> <p>STANDARD OF TUBULAR EXCHANGER MANUFACTURER'S ASSOCIATION.</p>		
<p>TALCHER THERMAL POWER PROJECT STAGE-III (2X660 MW) EPC PACKAGE</p>	<p>TECHNICAL SPECIFICATIONS SECTION VI, PART-C BID DOC. NO.:CS-4540-001A-2</p>	<p>GENERAL TECHNICAL REQUIREMENTS</p>	<p>PAGE 79 OF 114</p>

CLAUSE NO.	GENERAL TECHNICAL REQUIREMENTS			
	<p>CODE AND STANDARD FOR CIVIL WORKS</p> <p>Some of the applicable Standards, Codes and references are as follows:</p> <p>Excavation & Filling</p> <p>IS: 2720 (Part-II, IV TO VIII, XIV, XXI, XXIII, XXIV, XXVII TO XXIX, XL) Methods of test for soils-determination for water content etc.</p> <p>IS: 4701 Code of practice for earth work on canals.</p> <p>IS: 9758 Guidelines for Dewatering during construction.</p> <p>IS: 10379 Code of practice for field control of moisture and compaction of soils for embankment and sub-grade.</p> <p>Properties, Storage and Handling of Common Building Materials</p> <p>IS: 269 Specification for ordinary Portland cement, 33 grade.</p> <p>IS: 383 Specification for coarse and fine aggregates from natural sources for concrete.</p> <p>IS: 432 Specification for mild steel and (Parts 1&2) medium tensile steel bars and hard-drawn steel wires for concrete reinforcement.</p> <p>IS: 455 Specification for Portland slag cement.</p> <p>IS: 702 Specification for Industrial bitumen.</p> <p>IS: 712 Specification for building limes.</p> <p>IS: 808 Rolled steel Beam channel and angle sections.</p> <p>IS: 1077 Specification for common burnt clay building bricks.</p> <p>IS: 1161 Specification of steel tubes for structural purposes.</p> <p>IS: 1363 Hexagon head Bolts, Screws and nuts of production grade C.</p> <p>IS: 1364 Hexagon head Bolts, Screws and Nuts of Production grade A & B.</p> <p>IS: 1367 Technical supply conditions for Threaded fasteners.</p>			
<p>TALCHER THERMAL POWER PROJECT STAGE-III (2X660 MW) EPC PACKAGE</p>	<p>TECHNICAL SPECIFICATIONS SECTION VI, PART-C BID DOC. NO.:CS-4540-001A-2</p>	<p>GENERAL TECHNICAL REQUIREMENTS</p>	<p>PAGE 80 OF 114</p>	

CLAUSE NO.	GENERAL TECHNICAL REQUIREMENTS		
	IS: 1489 (Part-I) (Part-II) IS: 1542 IS: 1566 IS: 1786 IS: 2062 IS: 2116 IS: 2386 (Parts-I to VIII) IS: 3150 IS: 3495 (Parts-I to IV) IS: 3812 IS: 4031 IS: 4032 IS: 4082 IS: 8112 IS: 8500 IS: 12269 IS: 12894	Specification for Portland-pozzolana cement: Fly ash based. Calcined clay based. Specification for sand for plaster. Specification for hard-drawn steel wire fabric for concrete reinforcement. Specification for high strength deformed bars for concrete reinforcement. Specification for steel for general structural purposes. Specification for sand for masonry mortars. Testing of aggregates for concrete. Hexagonal wire netting for general purpose. Methods of tests of burnt clay building bricks. Specification for fly ash, for use as pozzolana and admixture. Methods of physical tests for hydraulic cement. Methods of chemical analysis of hydraulic cement. Recommendations on stacking and storage of construction materials at site. Specification for 43 grade ordinary portland cement. Medium and high strength structural steel. 53 grade ordinary portland cement. Specification for Fly ash lime bricks.	
TALCHER THERMAL POWER PROJECT STAGE-III (2X660 MW) EPC PACKAGE	TECHNICAL SPECIFICATIONS SECTION VI, PART-C BID DOC. NO.:CS-4540-001A-2	GENERAL TECHNICAL REQUIREMENTS	PAGE 81 OF 114

CLAUSE NO.	GENERAL TECHNICAL REQUIREMENTS		
Cast-In-Situ Concrete and Allied Works			
IS: 280		Specification for mild steel wire for general engineering purposes.	
IS: 456		Code of practice for plain and reinforced concrete.	
IS: 457		Code of practice for general construction of plain & reinforced concrete for dams & other massive structures.	
IS: 516		Method of test for strength of concrete.	
IS: 650		Specification for standard sand for testing of cement.	
IS: 1199		Methods of sampling and analysis of concrete.	
IS: 1791		General requirements for batch type concrete mixers.	
IS: 1838 (Part-I)		Specification for preformed fillers for expansion joints in concrete pavements and structures (non-extruding and resilient type).	
IS: 2204		Code of practice for construction of reinforced concrete shell roof.	
IS: 2210		Criteria for the design of reinforced concrete shell structures and folded plates.	
IS: 2438		Specification for roller pan mixer.	
IS: 2502		Code of practice for bending and fixing of bars for concrete reinforcement.	
IS: 2505		General requirements for concrete vibrators, immersion type.	
IS: 2506		General requirements for concrete vibrators, screed board type.	
IS: 2514		Specification for concrete vibrating tables.	
IS: 2645		Specification for Integral cement water proofing compounds.	
IS: 2722		Specification for portable swing weigh batches for concrete. (single and double bucket type)	
IS: 2750		Specification for Steel scaffolding.	
TALCHER THERMAL POWER PROJECT STAGE-III (2X660 MW) EPC PACKAGE	TECHNICAL SPECIFICATIONS SECTION VI, PART-C BID DOC. NO.:CS-4540-001A-2	GENERAL TECHNICAL REQUIREMENTS	PAGE 82 OF 114

CLAUSE NO.	GENERAL TECHNICAL REQUIREMENTS		
	IS: 2751 IS: 3025 IS: 3366 IS: 3370 (Part I to IV) IS: 3414 IS: 3550 IS: 3558 concrete. IS: 4014 (Parts I & II) IS: 4326 of buildings. IS: 4461 IS: 4656 IS: 4925 IS: 4990 IS: 4995 (Parts I & II) IS: 5256 IS: 5525 IS: 5624 IS: 6461	Code of practice for welding of mild steel plain and deformed bars for reinforced concrete construction. Methods of sampling and test waste water. Specification for Pan vibrators. Code of practice for concrete structures for the storage of liquids. Code of practice for design and installation of joints in buildings. Methods of test for routine control for water used in industry. Code of practice for use of immersion vibrators for consolidating concrete. Code of practice for steel tubular scaffolding. Code of practice for earthquake resistant design and construction of buildings. Code of practice for joints in surface hydro-electric power stations. Specification for form vibrators for concrete. Specification for batching and mixing plant. Specification for plywood for concrete shuttering work. Criteria for design of reinforced concrete bins for the storage of granular and powdery materials. Code or practice for sealing joints in concrete lining on canals. Recommendations for detailing of reinforcement in reinforced concrete work. Specification for foundation bolts. Glossary of terms relating to cement concrete.	
TALCHER THERMAL POWER PROJECT STAGE-III (2X660 MW) EPC PACKAGE	TECHNICAL SPECIFICATIONS SECTION VI, PART-C BID DOC. NO.:CS-4540-001A-2	GENERAL TECHNICAL REQUIREMENTS	PAGE 83 OF 114

CLAUSE NO.	GENERAL TECHNICAL REQUIREMENTS		
	IS: 6494 IS: 6509 IS: 7861 IS: 9012 IS: 9103 IS: 9417 IS: 10262 IS: 11384 IS: 11504 IS: 12118 IS: 12200 IS: 13311 Part-1 Part-2 SP:23 SP: 24 SP: 34 Precast Concrete Works SP: 7(PartVI/	Code of practice for water proofing of underground water reservoirs and swimming pools. Code of practice for installation of joints in concrete pavements. Code of practice for extreme weather concreting. (Parts I & II) Recommended practice for shot concreting. Specification for admixtures for concrete. Recommendations for welding cold worked steel bars for reinforced concrete construction. Recommended guidelines for concrete mix design. Code of practice for composite construction in structural steel and concrete. Criteria for structural design of reinforced concrete natural draught cooling towers. Specification for two-parts poly sulphide. Code of practice for provision of water stops at transverse contraction joints in masonry and concrete dams. Method of non-destructive testing of concrete. Ultrasonic pulse velocity. Rebound hammer. Handbook of concrete mixes Explanatory Handbook on IS: 456-1978 Handbook on concrete reinforcement and detailing. National Building Code- Structural design of prefabrication and Sec.7) systems building.	
TALCHER THERMAL POWER PROJECT STAGE-III (2X660 MW) EPC PACKAGE	TECHNICAL SPECIFICATIONS SECTION VI, PART-C BID DOC. NO.:CS-4540-001A-2	GENERAL TECHNICAL REQUIREMENTS	PAGE 84 OF 114

CLAUSE NO.	GENERAL TECHNICAL REQUIREMENTS		
	IS: 10297	Code of practice for design and construction of floors and roofs using precast reinforced/prestressed concrete ribbed or cored slab units.	
	IS: 10505	Code of practice for construction of floors and roofs using pre-cast reinforced concrete units.	
	Masonry and Allied Works		
	IS: 1905	Code of Practice for Structural Safety of Buildings-Masonry walls.	
	IS: 2212	Code of Practice for Brickwork.	
	IS: 2250	Code of Practice for Preparation and use of Masonry Mortar.	
	SP: 20	Explanatory handbook on masonry code.	
	Sheeting Works		
	IS:277	Galvanised steel sheets (plain or corrugated).	
	IS: 459	Unreinforced corrugated and semi-corrugated asbestos cement sheets.	
	IS: 513	Cold-rolled carbon steel sheets.	
	IS: 730	Specification for fixing accessories for corrugated sheet roofing.	
	IS: 1626	Specification for Asbestos cement building pipes and pipe fittings, gutters and gutter fittings and roofing fittings.	
	IS: 2527	Code of practice for fixing rain water gutters and down pipe for roof drainage.	
	IS: 3007	Code of practice for laying of asbestos cement sheets.	
	IS: 5913	Methods of test for asbestos cement products.	
	IS: 7178	Technical supply conditions for tapping screw.	
	IS: 8183	Bonded mineral wool.	
TALCHER THERMAL POWER PROJECT STAGE-III (2X660 MW) EPC PACKAGE	TECHNICAL SPECIFICATIONS SECTION VI, PART-C BID DOC. NO.:CS-4540-001A-2	GENERAL TECHNICAL REQUIREMENTS	PAGE 85 OF 114

CLAUSE NO.	GENERAL TECHNICAL REQUIREMENTS		
	IS: 8869	Washers for corrugated sheet roofing.	
	IS: 12093	Code of practice for laying and fixing of sloped roof covering using plain and corrugated galvanised steel sheets.	
	IS: 12866	Plastic translucent sheets made from thermosetting polyester resin (glass fibre reinforced).	
	IS: 14246	Specification for continuously pre-painted galvanised steel sheets and coils.	
	Fabrication and Erection of Structural Steel Work		
	IS: 2016	Specification for plain washers.	
	IS: 814	Specification for covered Electrodes for Metal Arc Welding for weld steel.	
	IS: 1852	Specification for Rolling and Cutting Tolerances for Hot rolled steel products.	
	IS: 3502	Specifications for chequered plate.	
	IS: 6911	Specification for stainless steel plate, sheet and strip.	
	IS: 3757	Specification for high strength structural bolts	
	IS: 6623	Specification for high strength structural nuts.	
	IS: 6649	High Tensile friction grip washers.	
	IS: 800	Code of practice for use of structural steel in general building construction.	
	IS: 816	Code of practice for use of Metal Arc Welding for General Construction.	
	IS: 4000	Code of practice for assembly of structural joints using high tensile friction grip fasteners.	
	IS: 9595	Code of procedure of Manual Metal Arc Welding of Mild Steel.	
	IS: 817	Code of practice for Training and Testing of Metal Arc Welders.	
TALCHER THERMAL POWER PROJECT STAGE-III (2X660 MW) EPC PACKAGE	TECHNICAL SPECIFICATIONS SECTION VI, PART-C BID DOC. NO.:CS-4540-001A-2	GENERAL TECHNICAL REQUIREMENTS	PAGE 86 OF 114

CLAUSE NO.	GENERAL TECHNICAL REQUIREMENTS		
	IS: 1811 IS: 9178 IS: 9006 IS: 7215 IS: 12843 IS: 4353 SP: 6 (Part 1 to 7) IS: 1608 IS: 1599 IS : 228 IS : 2595 IS : 1182 IS : 3664 IS : 3613 IS : 3658 IS : 5334	Qualifying tests for Metal Arc Welders (engaged in welding structures other than pipes). Criteria for Design of steel bins for storage of Bulk Materials. Recommended Practice for Welding of Clad Steel. Tolerances for fabrication steel structures. Tolerance for erection of structural steel. Recommendations for submerged arc welding of mild steel and low alloy steels. ISI Handbook for structural Engineers. Method of Tensile Testing of Steel products other than sheets, strip, wire and tube. Method of Bend Tests for Steel products other than sheet, strip, wire and tube Methods of chemical Analysis of pig iron, cast iron and plain carbon and low alloy steel. Code of Practice for Radio graphic testing. Recommended practice for Radiographic Examination of fusion welded butt joints in steel plates. Code of practice for Ultra sonic Testing by pulse echo method. Acceptance tests for wire flux combination for submerged Arc Welding. Code of practice for Liquid penetrant Flaw Detection. Code of practice for Magnetic Particle Flaw Detection of Welds.	
TALCHER THERMAL POWER PROJECT STAGE-III (2X660 MW) EPC PACKAGE	TECHNICAL SPECIFICATIONS SECTION VI, PART-C BID DOC. NO.:CS-4540-001A-2	GENERAL TECHNICAL REQUIREMENTS	PAGE 87 OF 114

CLAUSE NO.	GENERAL TECHNICAL REQUIREMENTS		
	<p>Plastering and Allied Works</p> <p>IS : 1635 Code of practice for field slaking of Building lime and preparation of putty.</p> <p>IS : 1661 Application of cement and cement lime plaster finishes.</p> <p>IS : 2333 Plaster-of-paris.</p> <p>IS : 2402 Code of practice for external rendered finishes.</p> <p>IS : 2547 Gypsum building plaster.</p> <p>IS : 3150 Hexagonal wire netting for general purpose.</p> <p>Acid and Alkali Resistant Lining</p> <p>IS : 158 Ready mixed paint, brushing, bituminous, black, lead free, acid, alkali & heat resisting.</p> <p>IS : 412 Specification for expanded metal steel sheets for general purpose.</p> <p>IS : 4441 Code of practice for use of silicate type chemical resistant mortars.</p> <p>IS : 4443 Code of practice for use of resin type chemical resistant mortars.</p> <p>IS : 4456 Method of test for chemical resistant tiles. (Part I & II)</p> <p>IS : 4457 Specification for ceramic unglazed vitreous acid resistant tiles.</p> <p>IS : 4832 Specification for chemical resistant mortars.</p> <p style="padding-left: 40px;">Part I Silicate type</p> <p style="padding-left: 40px;">Part II Resin type</p> <p style="padding-left: 40px;">Part III Sulphur type</p> <p>IS : 4860 Specification for acid resistant bricks.</p> <p>IS : 9510 Specification for bitumasitic, Acid resisting grade.</p>		
<p style="text-align: center;">TALCHER THERMAL POWER PROJECT STAGE-III (2X660 MW) EPC PACKAGE</p>	<p style="text-align: center;">TECHNICAL SPECIFICATIONS SECTION VI, PART-C BID DOC. NO.:CS-4540-001A-2</p>	<p style="text-align: center;">GENERAL TECHNICAL REQUIREMENTS</p>	<p style="text-align: center;">PAGE 88 OF 114</p>

CLAUSE NO.	GENERAL TECHNICAL REQUIREMENTS		एनटीपीसी NTPC
	<p>Water Supply, Drainage and Sanitation</p> <p>IS : 458 Specification for concrete pipes.</p> <p>IS : 554 Dimensions for pipe threads, where pressure tight joints are made on thread.</p> <p>IS : 651 Specification for salt glazed stoneware pipes.</p> <p>IS : 774 Flushing cisterns for water closets and urinals.</p> <p>IS : 775 Cast iron brackets and supports for wash basins and sinks.</p> <p>IS : 778 Copper alloy gate, globe and check valves for water works purposes.</p> <p>IS : 781 Cast copper alloy screw down bib taps and stop valves for water services.</p> <p>IS : 782 Caulking lead.</p> <p>IS : 783 Code of practice for laying of concrete pipes.</p> <p>IS : 1172 Basic requirements for water supply, drainage and sanitation.</p> <p>IS : 1230 Cast iron rain water pipes and fittings.</p> <p>IS : 1239 Mild steel tubes, tubulars and other wrought steel fittings.</p> <p>IS : 1536 Centrifugally cast (Spun) iron pressure pipes for water, gas and sewage.</p> <p>IS : 1537 Vertically cast iron pressure pipes for water, gas and sewage.</p> <p>IS : 1538 Cast iron fittings for pressure pipe for water, gas and sewage.</p> <p>IS : 1703 Ball valves (horizontal plunger type) including float for water supply purposes.</p> <p>IS : 1726 Cast iron manhole covers and frames.</p> <p>IS : 1729 Sand cast iron spigot and socket, soil, water and ventilating pipes, fittings and accessories.</p>		
TALCHER THERMAL POWER PROJECT STAGE-III (2X660 MW) EPC PACKAGE	TECHNICAL SPECIFICATIONS SECTION VI, PART-C BID DOC. NO.:CS-4540-001A-2	GENERAL TECHNICAL REQUIREMENTS	PAGE 89 OF 114

CLAUSE NO.	GENERAL TECHNICAL REQUIREMENTS		
	IS : 1742 IS : 1795 IS : 1879 IS : 2064 IS : 2065 IS : 2326 IS : 2470 (Part-I & II) IS : 2501 IS : 2548 IS : 2556 (Part 1 to 15) IS : 2963 IS : 3114 IS : 3311 IS : 3438 IS : 3486 IS : 3589 IS : 3989 IS : 4111 (Part I to IV) IS : 4127	Code of practice for building drainage. Pillar taps for water supply purposes. Malleable cast iron pipe fittings. Code of practice for selection, installation and maintenance of sanitary appliances. Code of practice for water supply in building. Automatic flushing cisterns for urinals. Code of practice for installation of septic tanks. Copper tubes for general engineering purposes. Plastic seat and cover for water-closets. Vitreous sanitary appliances (vitreous china). Non-ferrous waste fittings for wash basins and sinks. Code of practice for laying of cast iron pipes. Waste plug and its accessories for sinks and wash basins. Silvered glass mirrors for general purposes. Cast iron spigot and socket drain pipes. Electrically welded steel pipes for water, gas and sewage (200mm to 2000mm nominal diameter). Centrifugally cast (Spun) iron spigot and socket soil, waste and ventilating pipes, fittings and accessories. Code of practice for ancillary structure in sewerage system. Code of practice for laying of glazed stone-ware pipes.	
TALCHER THERMAL POWER PROJECT STAGE-III (2X660 MW) EPC PACKAGE	TECHNICAL SPECIFICATIONS SECTION VI, PART-C BID DOC. NO.:CS-4540-001A-2	GENERAL TECHNICAL REQUIREMENTS	PAGE 90 OF 114

CLAUSE NO.	GENERAL TECHNICAL REQUIREMENTS		
	IS : 4764 IS : 4827 IS : 5329 IS : 5382 IS : 5822 IS : 5961 IS : 7740 IS : 8931 IS : 8934 IS : 9762 IS : 10446 IS : 10592 IS : 12592 IS : 12701 SP: 35 - Doors, Windows and Allied Works IS : 204 Part-I Part-II	Tolerance limits for sewage effluents discharged into inland-surface waters. Electro plated coating of nickel and chromium on copper and copper alloys. Code of practice for sanitary pipe work above ground for buildings. Rubber sealing rings for gas mains, water mains and sewers. Code of practice for laying of welded steel pipes for water supply. Cast iron grating for drainage purpose. Code of practice for road gullies. Cast copper alloy fancy bib taps and stop valves for water services. Cast copper alloy fancy pillar taps for water services. Polyethylene floats for ball valves. Glossary of terms for water supply and sanitation. Industrial emergency showers, eye and face fountains and combination units. Specification for precast concrete manhole covers and frames. Rotational moulded polyethylene water storage tanks. Handbook on water supply and drainage. Manual on Sewerage and sewage treatment (Published by CPH & EEO) As updated.	
TALCHER THERMAL POWER PROJECT STAGE-III (2X660 MW) EPC PACKAGE	TECHNICAL SPECIFICATIONS SECTION VI, PART-C BID DOC. NO.:CS-4540-001A-2	GENERAL TECHNICAL REQUIREMENTS	PAGE 91 OF 114

CLAUSE NO.	GENERAL TECHNICAL REQUIREMENTS		
	IS : 208 IS : 281 IS : 362 IS : 420 IS : 1003 Part-I door IS : 1038 IS : 1081 IS : 1341 IS : 1361 IS : 1823 IS : 1868 IS : 2202 (Part-II) IS:2209 IS:2553 IS:2835 IS:3548 IS:3564 IS : 3614 IS:4351 IS:5187 IS:5437	Door Handles. Mild steel sliding door bolts for use with padlocks. Parliament Hinges. Specification for putty, for use on metal frames. Specification for timber panelled and glazed shutters- (Part-I) shutters. Steel doors, windows and ventilators. Code of practice for fixing and glazing of metal (steel and aluminium) doors, windows and ventilators. Steel butt hinges. Steel windows for industrial buildings. Floor door stoppers. Anodic coatings on Aluminium and its alloys. Specification for wooden flush door shutters (solid core type); particle board face panels and hard board face panels Mortice locks (vertical type). Safety glass Flat transparent sheet glass. Code of practice for glazing in buildings. Door closers (Hydraulically regulated). Fire check doors; plate, metal covered and rolling type. Steel door frames. Flush bolts. Wired and figured glass	
TALCHER THERMAL POWER PROJECT STAGE-III (2X660 MW) EPC PACKAGE	TECHNICAL SPECIFICATIONS SECTION VI, PART-C BID DOC. NO.:CS-4540-001A-2	GENERAL TECHNICAL REQUIREMENTS	PAGE 92 OF 114

CLAUSE NO.	GENERAL TECHNICAL REQUIREMENTS		
	IS:6248	Metal rolling shutters and rolling grills.	
	IS:6315	Floor springs (hydraulically regulated) for heavy doors.	
	IS:7196	Hold fasts.	
	IS:7452	Hot rolled steel sections for doors, windows and ventilators.	
	IS:10019	Mild steel stays and fasteners.	
	IS:10451	Steel sliding shutters (top hung type).	
	IS:10521	Collapsible gates.	
	Roof Water Proofing and Allied Works		
	IS:1203	Methods of testing tar and bitumen.	
	IS:1322	Specification for bitumen felts for water proofing and damp proofing.	
	IS:1346	Code of practice for water proofing of roofs with bitumen felts.	
	IS:1580	Specification for bituminous compound for water proofing and caulking purposes.	
	IS:3067	Code of practice for general design details and preparatory work for damp proofing and water proofing of buildings.	
	IS:3384	Specification for bitumen primer for use in water proofing and damp proofing.	
	Floor Finishes and Allied Works		
	IS:1237	Specification for cement concrete flooring tiles.	
	IS:1443	Code of practice for laying and finishing of cement concrete flooring tiles.	
	IS:2114	Code of practice for laying in-situ terrazzo floor finish.	
	IS:2571	Code of practice for laying in-situ cement concrete flooring.	
	IS:3462	Specification for unbacked flexible PVC flooring.	
	IS:4971	Recommendations for selection of industrial floor finishes.	
TALCHER THERMAL POWER PROJECT STAGE-III (2X660 MW) EPC PACKAGE	TECHNICAL SPECIFICATIONS SECTION VI, PART-C BID DOC. NO.:CS-4540-001A-2	GENERAL TECHNICAL REQUIREMENTS	PAGE 93 OF 114

CLAUSE NO.	GENERAL TECHNICAL REQUIREMENTS		
	IS:5318	Code of practice for laying of flexible PVC sheet and tile flooring.	
	IS:8042	Specification for white portland cement.	
	IS:13801	Specification for chequered cement concrete flooring tiles.	
	Painting and Allied Works		
	IS:162	Specification for fire resisting silicate type, brushing, for use on wood, colour as required.	
	IS:1477	Code of practice for painting of ferrous metals in buildings.	
	Part-I	Pretreatment.	
	Part-II	Painting.	
	IS:1650	Specification for colours for building and decorative finishes.	
	IS:2074	Specification for red oxide-zinc chrome, priming, ready mixed paint air drying.	
	IS:2338	Code of practice for finishing of wood and wood based materials.	
	Part-I	Operations and workmanship	
	Part-II	Schedules	
	IS:2395	Code of practice for painting concrete, masonry and plaster surfaces.	
	Part-I	Operations and workmanship.	
	Part-II	Schedule.	
	IS:2524	Code of practice for painting of nonferrous metals in buildings.	
	Part-I	Pretreatment.	
	Part-II	Painting.	
	IS:2932	Specification of synthetic enamel paint, exterior, under-coating and finishing.	
	IS:2933	Specification enamel paint, under coating and finishing.	
	IS:4759	Code of practice for hot dip zinc coating on structural steel and other allied products.	
	IS:5410	Specification for cement paint	
TALCHER THERMAL POWER PROJECT STAGE-III (2X660 MW) EPC PACKAGE	TECHNICAL SPECIFICATIONS SECTION VI, PART-C BID DOC. NO.:CS-4540-001A-2	GENERAL TECHNICAL REQUIREMENTS	PAGE 94 OF 114

CLAUSE NO.	GENERAL TECHNICAL REQUIREMENTS		
	IS:5411 (Part-I)	Specification for plastic emulsion paint-for exterior use	
	IS:6278	Code of practices for white washing and colour washing.	
	IS:10403	Glossary of terms relating to building finishes.	
	Piling and Foundation		
	IS:1080	Code of practice for design and construction of simple spread foundations.	
	IS:1904	Code of practice for design and construction of foundations in Soils; General Requirements.	
	IS:2911	Code of practice for designs and construction of Pile foundations (Relevant Parts).	
	IS:2950	Code of practice for designs and construction of Raft (Part-I) foundation.	
	IS:2974 (Part-I TO V)	Code of practice for design and construction of machine foundations.	
	IS:6403	Code of practice for determination of Allowable Bearing pressure on Shallow foundation.	
	IS:8009	Code of practice for calculation of settlement of foundation subjected to symmetrical vertical loads.	
	Part-I	Shallow foundations.	
	Part-II	Deep foundations.	
	IS:12070	Code of practice for design and construction of shallow foundations on rocks.	
	DIN:4024	Flexible supporting structures for machines with rotating machines.	
	VDI:2056	Criteria for assessing mechanical vibrations of machines.	
	VDI:2060	Criteria for assessing rotating imbalances in machines.	
	Stop Log and Trash Rack		
	IS:4622	Recommendations for fixed - wheel gates structural design.	
	IS:5620	Recommendations for structural design criteria for low head slide gates.	
	IS:11388	Recommendations for design of trash rack for intakes.	
	IS:11855	General requirements for rubber seals for hydraulic gates.	
	Roads		
TALCHER THERMAL POWER PROJECT STAGE-III (2X660 MW) EPC PACKAGE	TECHNICAL SPECIFICATIONS SECTION VI, PART-C BID DOC. NO.:CS-4540-001A-2	GENERAL TECHNICAL REQUIREMENTS	PAGE 95 OF 114

CLAUSE NO.	GENERAL TECHNICAL REQUIREMENTS		
IRC:5		Standard specifications and Code of practice for road bridges, section-I general Features of Design.	
IRC:14		Recommended practice of 2cm thick bitumen and tar carpets.	
IRC:16		Specification for priming of base course with bituminous primers.	
IRC:19		Standard specifications and code of practice for water bound macadam.	
IRC:21		Standard specifications and Code of practice for road bridges, section-III - Cement concrete (plain and reinforced).	
IRC:34		Recommendations for road construction in waterlogged areas.	
IRC:36		Recommended practice for the construction of earth embankments for road works.	
IRC:37		Guidelines for the Design of flexible pavements.	
IRC:56		Recommended practice for treatment of embankment slopes for erosion control.	
IRC:73		Geometric design standards for rural (non-urban) highways.	
IRC:86		Geometric Design standards for urban roads in plains.	
IRC:SP:13		Guidelines for the design of small bridges & culverts.	
IRC - Public- ation		Ministry of Surface Transport (Roads Wing), Specifications for road and bridge works.	
IS:73		Specification for paving bitumen	
Loadings			
IS:875 (Pt. I to V)		Code of practice for design loads other than earthquake) for buildings and structures.	
IS:1893		Criteria for earthquake resistant design of structures.	
IS:4091		Code of Practice for design and construction of foundation for transmission line towers & poles.	
IRC:6		Standard specifications & code of practice for road bridges, Section-II Loads and stresses.	
M.O.T.		Deptt. of railways Bridge Rules.	
Safety			
IS:3696 (Part I & II)		Safety code for scaffolds and ladders.	
TALCHER THERMAL POWER PROJECT STAGE-III (2X660 MW) EPC PACKAGE	TECHNICAL SPECIFICATIONS SECTION VI, PART-C BID DOC. NO.:CS-4540-001A-2	GENERAL TECHNICAL REQUIREMENTS	PAGE 96 OF 114

CLAUSE NO.	GENERAL TECHNICAL REQUIREMENTS		
	IS:3764 IS:4081 IS:4130 IS:5121 IS:5916 IS:7205 IS:7293 IS:7969 IS:11769 - Architectural design of buildings SP:7 SP:41 Miscellaneous IS:802 (Relevant parts) IS:803 IS:10430 IS:11592 IS:12867 CIRIA Publication	Safety code for excavation work. Safety code for blasting and related drilling operations. Safety code for demolition of buildings. Safety code for piling and other deep foundations. Safety code for construction involving use of hot bituminous materials. Safety code for erection on structural steelwork. Safety code for working with construction machinery. Safety code for handling and storage of building materials Guidelines for safe use of products containing asbestos. Indian Explosives Act. 1940 as updated. National Building Code of India Handbook on functional requirements of buildings (other than industrial buildings) Code of practice for use of structural steel in overhead transmission line towers. Code of practice for design, fabrication and erection of vertical mild steel cylindrically welded in storage tanks. Creteria for design of lined canals and liner for selection of type of lining. Code of practice for selection and design of belt conveyors. PVC handrails covers. Design and construction of buried thin-wall pipes.	
TALCHER THERMAL POWER PROJECT STAGE-III (2X660 MW) EPC PACKAGE	TECHNICAL SPECIFICATIONS SECTION VI, PART-C BID DOC. NO.:CS-4540-001A-2	GENERAL TECHNICAL REQUIREMENTS	PAGE 97 OF 114

CLAUSE NO.	GENERAL TECHNICAL REQUIREMENTS			
	<p>REFERENCE CODES AND STANDARDS FOR CONTROL AND INSTRUMENTATION</p> <p>The design, manufacture, inspection, testing & installation of all equipment and system covered under this specification shall conform to the latest editions of codes and standards mentioned below and all other applicable VDE, IEEE, ANSI, ASME, NEC, NEMA, ISA AND Indian Standards and their equivalents.</p> <p>Temperature Measurements</p> <ol style="list-style-type: none"> 1. Instrument and apparatus for temperature measurement - ASME PTC 19.3 (1974). 2. Temperature measurement - Thermocouples ANSI MC 96.1 - 1982. 3. Temperature measurement by electrical Resistance thermometers - IS:2806. 4. Thermometer - element - Platinum resistance - IS:2848. <p>Pressure Measurements</p> <ol style="list-style-type: none"> 1. a) Instruments and apparatus for pressure measurement - ASME PTC 19.2 (1964). <li style="padding-left: 20px;">b) Electronic transmitters BS:6447. 2. Bourdon tube pressure and vacuum gauges - IS:3624 - 1966. 3. Process operated switch devices (Pr. Switch) BS-6134. <p>Flow Measurements</p> <p>Instruments and apparatus for flow measurements - ASME PTC 19.5 (1972) Interim supplement, Part-II.</p> <p>Measurement of fluid flow in closed conduits - BS-1042.</p> <p>Electronic Measuring Instrument & Control Hardware/ Software</p> <ol style="list-style-type: none"> 1. Automatic null balancing electrical measuring instruments - ANSI C 39.4 (Rev. 1973): IS:9319. 2. Safety requirements for electrical and electronic measuring and controlling instrument - ANSI C 39.5 - 1974. 3. Compatibility of analog signals for electronic industrial process instruments - ISA - S 50.1 (1982) ANSI MC 12.1 - 1975. 4. Dynamic response testing of process control instrumentation ISA - S 26 (1968). 			
<p>TALCHER THERMAL POWER PROJECT STAGE-III (2X660 MW) EPC PACKAGE</p>	<p>TECHNICAL SPECIFICATIONS SECTION VI, PART-C BID DOC. NO.:CS-4540-001A-2</p>	<p>GENERAL TECHNICAL REQUIREMENTS</p>	<p>PAGE 98 OF 114</p>	

CLAUSE NO.	GENERAL TECHNICAL REQUIREMENTS			
	<ol style="list-style-type: none"> 5. Surge Withstand Capability (SWC) tests - ANSI C 37.90 a/IEEE-472 or suitable class of IEC-255-4 equivalent to ANSI C37.90a/IEEE-472. 6. Printed circuit boards - IPC TM - 650, IEC 326 C. 7. General requirement and tests for printed wiring boards - IS 7405 (Part-I) 1973. 8. Edge socket connectors - IEC 130-11. 9. Requirements and methods of testing of wire wrap terminations DIN 41611 Part-2. 10. Dimensions of attachment plugs & receptacles - ANSI C 73 - 1973 (Supplement ANSI C 73 a - 1980). 11. Direct acting electrical indicating instrument - IS:1248 - 1968 (R). 12. Standard Digital Interface for Programmable Instrumentation - IEEE-488.2 - 1990. 13. Information Processing Systems - Local Area Networks - Part 2 : Logical Link Control - IEEE-802.2 - 1989. 14. Standard for Local Area Networks : Carrier Sense Multiple Access with Collision Detection - IEEE-802.3 - 1985. 15. Supplements A, B, C and E to Carrier Sense Multiple Access with Collision Detection - IEEE-802.3 - 1988. 16. Standard for Local Area Networks : Token - Passing Bus Access Method - IEEE-802.4 - 1985. 17. Standard for Local Area Networks : Token - Ring Access Method and Physical Layer Specification - IEEE-802.5 - 1985. 18. IEEE Guide to Software Requirements Specifications - IEEE-830 - 1984. 19. Hardware Testing of Digital Process Computers - ISA RP55.1 - 1983. 20. Electromagnetic Susceptibility of Process Control Instrumentation - SAMA PMC 33.1 - 1978. 21. Interface Between the Data Terminal Equipment and Data Circuit - Terminating Equipment Employing Serial Binary Data Interchange - EIA-232-D-1987. 22. Electromagnetic Compatibility for Industrial Process Measurement and Control Equipment, Part 3 : Radiated Electromagnetic Field Requirements - IEC 801-3-1984. 			
<p style="text-align: center;">TALCHER THERMAL POWER PROJECT STAGE-III (2X660 MW) EPC PACKAGE</p>	<p style="text-align: center;">TECHNICAL SPECIFICATIONS SECTION VI, PART-C BID DOC. NO.:CS-4540-001A-2</p>	<p style="text-align: center;">GENERAL TECHNICAL REQUIREMENTS</p>	<p style="text-align: center;">PAGE 99 OF 114</p>	

CLAUSE NO.	GENERAL TECHNICAL REQUIREMENTS			
	<p>Instrument Switches and Contact</p> <ol style="list-style-type: none"> 1. Contact rating - AC services NEMA ICS 2 - 1978 (with revision through May 1983), Part - 2-125, A6000. 2. Contact rating - DC services NEMA ICS 2-1978 Part-2 125, N600. <p>Enclosures</p> <ol style="list-style-type: none"> 1. Type of Enclosures - NEMA ICS Part - 6 - 1978 (with Rev. 1 4/80) through 110.22 (Type 4 to 13). 2. Racks, panels and associated equipment - EIA : RS - 310 C- 1983 (ANSI C 83.9 - 1972). 3. Protection class for Enclosures, cabinets, control panels & desks - IS:2147 - 1962. <p>Apparatus, enclosures and installation practices in hazardous area</p> <ol style="list-style-type: none"> 1. Classification of hazardous area - NFPA 70 - 1984, Article 500. 2. Electrical Instruments in hazardous dust location - ISA - 512.11, 1973. 3. Intrinsically safe apparatus - NFPA 493 1978. 4. Purged and pressurised enclosure for electrical equipment in hazardous location - NFPA 496-1982. 5. Enclosures for Industrial Controls and Systems - NEMA IS 1.1 - 1977. <p>Sampling System</p> <ol style="list-style-type: none"> 1. Stainless steel material of tubing and valves for sampling system - ASTM A 296-82, Grade 7 P 316. 2. Submerged helical coil heat exchangers for sample coolers ASTM D11 92-1977. 3. Water and steam in power cycle - ASME PTC 19.11. 4. Standard methods of sampling system - ASTM D 1066-99. <p>Annunciators</p> <ol style="list-style-type: none"> 1. Specifications and guides for the use of general purpose annunciators - ISA S 19.1, 1979. 2. Surge withstand capability tests - ANSI C 37.90a - 1989/IEEE-472 or suitable class of IEC 255-4 equivalent to ANSI C37.90a 1989/IEEE-472 3. Damp heat cycling test - IS:2106 			
<p>TALCHER THERMAL POWER PROJECT STAGE-III (2X660 MW) EPC PACKAGE</p>	<p>TECHNICAL SPECIFICATIONS SECTION VI, PART-C BID DOC. NO.:CS-4540-001A-2</p>	<p>GENERAL TECHNICAL REQUIREMENTS</p>	<p>PAGE 100 OF 114</p>	

CLAUSE NO.	GENERAL TECHNICAL REQUIREMENTS			
	<p>4. Specification for Electromagnetic Susceptibility - SAMA DMC 33, 1/78</p> <p>Protections</p> <ol style="list-style-type: none"> 1. Relays and relay system associated with electric power apparatus. ANSI C 37.90, 1 - 1989. 2. General requirements & tests for switching devices for control and auxiliary circuits including contactor relays - IS:6875 (Part-I) - 1973. 3. Turbine water damage prevention - ASME TDP-1-1980. 4. Boiler safety interlocks - NFPA Section 85 B - 1984, 85 C - 1991. <p>UPS System</p> <ol style="list-style-type: none"> 1. Practices and requirements for semi-conductor power rectifiers - ANSI C 34.2, 1973. 2. Relays and relays system associated with electrical power apparatus - ANSI C 3.90 - 1983. 3. Surge withstand capability test - ANSI C 37.90 1 -1989. 4. Performance testing of UPS - IEC 146. 5. Stationary cells & Batteries Lead Acid type (with tubular positive plates) specification IS-1651-1991. 6. Recommended practice for sizing large lead storage batteries for generating stations & sub-stations - IEEE-485-1985. 7. Printed Circuit Board - IPC TM 650, IEC 326C. 8. General Requirements & tests for printed wiring boards, IS:7405 (Part-I) 1973. <p>Control Valves</p> <ol style="list-style-type: none"> 1. Control valve sizing - Compressible & Incompressible fluids - ISA S 75.01-1985. 2. Face to face dimensions of control valves - ANSI B 16.00 - 1973. 3. ISA Hand Book of Control Valves - (ISBN : B: 1047-087664-234-2). 4. Codes for pressure piping - ANSI B 31.1 5. Control Valve leak class - ISA RP 39.6 			
<p>TALCHER THERMAL POWER PROJECT STAGE-III (2X660 MW) EPC PACKAGE</p>	<p>TECHNICAL SPECIFICATIONS SECTION VI, PART-C BID DOC. NO.:CS-4540-001A-2</p>	<p>GENERAL TECHNICAL REQUIREMENTS</p>	<p>PAGE 101 OF 114</p>	

CLAUSE NO.	GENERAL TECHNICAL REQUIREMENTS			
	<p>Process Connection & Piping</p> <ol style="list-style-type: none"> 1. Codes for pressure piping "power piping" - ANSI B 31.1. 2. Seamless carbon steel pipe ASTM - A - 106. 3. Forged & Rolled Alloy steel pipe flanges, forged fittings and valves and parts - ASTM - A - 182. 4. Material for socket welded fittings - ASTM - A - 105. 5. Seamless ferritic alloy steep pipe - ASTM - A - 335. 6. Pipe fittings of wrought carbon steel and alloy steel - ASTM - A - 234. 7. Composition bronze of ounce metal castings - ASTM - B - 62. 8. Seamless Copper tube, bright annealed - ASTM - B - 168. 9. Seamless copper tube - ASTM - B - 75. 10. Dimension of fittings - ANSI - B - 16.11. 11. Valves flanged and butt welding ends - ANSI - B - 16.34. <p>Instrument Tubing</p> <ol style="list-style-type: none"> 1. Seamless carbon steel pipe - ASTM - A 106. 2. Material of socketweld fittings - ASTM - A105. 3. Dimensions of fittings - ANSI - B - 16.11. 4. Code for pressure piping, welding, hydrostatic testing - ANSI B 31.1. <p>Cables</p> <ol style="list-style-type: none"> 1. Thermocouples extension wires/cables - ANSI MC 96.1 - 1992. 2. Requirements for copper conductor-Wiring cables for telecommunications & information processing system - VDE:0815. 3. Colour coding of single or multi-pair cables - ICEA - S - 61-402 (third edition) NEMA WCS - 1979 with revisions through 2/83. 4. Insulation & Sheathing compounds for cables : VDE 0207 (Part-4, 5 & 6). 5. Guide design and installation of cable systems in power generating stations (insulation, jacket materials) - IEEE Std. 422-1977. 6. Rules for Testing insulated cables and flexible cables : VVDE - 0472 7. Requirements of vertical flame propagation test - IEEE 383 - 1974 (R 1980) 			
<p>TALCHER THERMAL POWER PROJECT STAGE-III (2X660 MW) EPC PACKAGE</p>	<p>TECHNICAL SPECIFICATIONS SECTION VI, PART-C BID DOC. NO.:CS-4540-001A-2</p>	<p>GENERAL TECHNICAL REQUIREMENTS</p>	<p>PAGE 102 OF 114</p>	

CLAUSE NO.	GENERAL TECHNICAL REQUIREMENTS			
	<p>8. Standard specification for tinned soft or annealed copper wire for electrical purpose - ASTM B-33-81.</p> <p>9. Oxygen index and temperature index test - ASTM D - 2863.</p> <p>10. Smoke density measurement test - ASTM D - 2843.</p> <p>11. Acid gas generation test - IEC - 754 - 1.</p> <p>12. Swedish Chimney test - SEN - 4241475 (F3).</p> <p>13. Teflon (FEP) insulation & sheath test - ASTM D - 2116.</p> <p>14. Thermocouple compensating cables - Testing requirements & sampling plan IS:8784.</p> <p>15. PVC insulated electric cables for working voltage upto and including 1100 V - IS:1554 (Part-I).</p> <p>Cable Trays, Conduits</p> <p>1. Guide for design and installation of cable systems in power generating station (Cable trays, support systems, conduits) - IEEE Std. 422, 1977, NEMA VE-1 1979, NFPA 70-1984.</p> <p>2. -do- Test Standards. NEMA VE-1-1979.</p> <p>3. Zinc coating "hot dip" on assembled products for galvanising of carbon steel cable trays - ASTM A - 386-78.</p> <p>Public Address System</p> <p>1. Specifications for loud speakers - IS:7741 (Part-I, II and III)</p> <p>2. Code of safety requirement for electric mains operated audio amplifiers - IS:1301</p> <p>3. Specification for Public Address Amplifiers - IS:10426.</p> <p>4. Code of practice for outdoor installation of PA system - IS:1982.</p> <p>5. Code of practice for installation for indoor amplifying and sound distribution system - IS:1881.</p> <p>6. Basic environmental testing procedures for electronic and electrical items - IS:9000.</p> <p>7. Characteristics and methods of measurements for sound system equipment - IS:9302</p> <p>8. Code of practice of electrical wiring installations (System voltage not exceeding 650 volts) - IS:732</p>			
<p>TALCHER THERMAL POWER PROJECT STAGE-III (2X660 MW) EPC PACKAGE</p>	<p>TECHNICAL SPECIFICATIONS SECTION VI, PART-C BID DOC. NO.:CS-4540-001A-2</p>	<p>GENERAL TECHNICAL REQUIREMENTS</p>	<p>PAGE 103 OF 114</p>	

CLAUSE NO.	GENERAL TECHNICAL REQUIREMENTS			
	<p>9. Rigid steel conduits for electric wiring - IS:9537 (Part-I and II)</p> <p>10. Fittings for rigid steel conduits for electrical wiring - IS:2667</p> <p>11. Degree of protection provided by enclosure for low voltage switchgear and control gear - IS:2147.</p> <p>Vibration Monitoring System</p> <p>1. API 670 - 1994</p> <p>2. BS : 4675 Part-2</p>			
<p>TALCHER THERMAL POWER PROJECT STAGE-III (2X660 MW) EPC PACKAGE</p>	<p>TECHNICAL SPECIFICATIONS SECTION VI, PART-C BID DOC. NO.:CS-4540-001A-2</p>	<p>GENERAL TECHNICAL REQUIREMENTS</p>	<p>PAGE 104 OF 114</p>	

ANNEXURE-III

	Project :	Stage ::	LIST OF ITEMS REQUIRING QUALITY PLAN AND SUB-SUPPLIER APPROVAL					DOC. NO.:		
	Package :							REV. NO.:		
	Supplier :		SUB-SYSTEM :					DATE :		
	Contractor No. :							PAGE : OF		
S. N.	Item	QP/ Insp. Cat.	QP No.	QP Sub. Schedule	QP approval schedule	Proposed sub-supplier	Place	Sub-suppliers approval status / category	Sub-supplier Details submission schedule	Remarks

LEGENDS

SYSTEM SUPPLIER/SUB-SUPPLIER APPROVAL STATUS CATEGORY (SHALL BE FILLED BY NTPC)

A – For these items proposed vendor is acceptable to NTPC. To be indicated with letter “A” in the list alongwith the condition of approval, if any.

DR – For these items “Detailed required” for NTPC review. To be identified with letter “DR” in the list.

NOTED – For these items vendors are approved by Main Supplier and accepted by NTPC without specific vendor approval from NTPC. To be identified with “NOTED.”

QP/INSPN CATEGORY:

CAT-I : For these items the Quality Plans are approved by NTPC and the final acceptance will be on physical inspection witness by NTPC.

CAT-II : For these items the Quality Plans approved by NTPC. However no physical inspection shall be done by NTPC. The final acceptance by NTPC shall be on the basis review of documents as per approved QP.

CAT-III : For these items Main Supplier approves the Quality Plans. The final acceptance by NTPC shall be on the basis certificate of conformance by the main supplier.

UNITS/WORKS : Place of manufacturing Place of Main Supplier of multi units/works.

FORMAT NO.: QS-01-QAI-P-1/F3-R0

1/1

Engg. Div. / QA&I

TALCHER THERMAL POWER PROJECT STAGE-III (2X660 MW) EPC PACKAGE	TECHNICAL SPECIFICATION SECTION – VI, PART-C BID DOC.NO.: CS-4540-001A-2	GENERAL TECHNICAL REQUIREMENT	PAGE 105 OF 114
---	---	--------------------------------------	------------------------

ANNEXURE-IV

	Project :	Stage ::	STATUS OF ITEM REQUIRING QP& SUB-SUPPLIER APPROVAL					DOC. NO.:			
	Package :							REV. NO.:			
	Contractor :							DATE :			
	Contractor No. :							PAGE : OF			
S. N.	Item / Service	QP/ Insp. Cat.	QP Sub. Schedule Approval schedule	Date of sub-mission	Date of commt Appl.	Status Code C/II/I	Proposed Sub-suppliers	Place of manufacturing works	Approval Status	Sub-supplier detail submission schedule	Remarks
FORMAT						1/1			Engg. Div. / QA&I		

TALCHER THERMAL POWER PROJECT STAGE-III (2X660 MW) EPC PACKAGE	TECHNICAL SPECIFICATION SECTION – VI, PART-C BID DOC.NO.: CS-4540-001A-2	GENERAL TECHNICAL REQUIREMENT	PAGE 106 OF 114
---	--	----------------------------------	-----------------

ANNEXURE-V

	Project : _____		Stage : _____		FIELD WELDING SCHEDULE (To be raised by the contractor) Welding Code:							DOC. NO.: _____				
	Contractor : _____											REV. NO.: _____				
	Contractor No. : _____											DATE : _____				
	System : _____											PAGE : _____ OF _____				
Sl. No.	DRG No. for Weld Location and Identification mark	Description of parts to welded	Matl. Spec.	Dimensions		Process of welding	Type of Weld	Electrode filler spec.	WPS. No.	Min. pre-heat	Heat treatment		NDT method/ Quantum	REF		Remarks
											Temp.	Holding time		Spec. No.	ACC Norm Ref.	
NOTES:																
SIGNATURE																
FORMAT						1/1						Engg. Div. / QA&I				

TALCHER THERMAL POWER PROJECT STAGE-III (2X660 MW) EPC PACKAGE	TECHNICAL SPECIFICATION SECTION – VI, PART-C BID DOC.NO.: CS-4540-001A-2	GENERAL TECHNICAL REQUIREMENT	PAGE 107 OF 114
---	--	----------------------------------	-----------------

CLAUSE NO.	GENERAL TECHNICAL REQUIREMENTS (Annexure-VI)			एनटीपीसी NTPC
	S. No.	Description of Drgs./Docs.	No. of Prints	No. of Portable Hard Disk
	1	Drawings, Data sheets, Design calculations, Purchase specifications and other documents First submission and submission with major changes <ul style="list-style-type: none"> ▪ Layout (A0&A1 sizes) ▪ Other Drawings/Documents (A0 & A1 sizes) ▪ P&ID (All sizes) a) Final drawings/documents (Directly to site) b) "As Built" Drawing/Documents (Directly to site) c) Analysis reports of Equipments / piping / structures components/system employing software packages as detailed in the specifications.	4 2 4 6 6 2	- - - 2 2 2
	2	Erection Manual (Directly to site)	4 sets	2
	3	Operation & Maintenance manual		
		i) First Submission	1 set	--
		ii) Final Submission (Directly to site)	4 sets	2
	4	Plant Hand Book		
		i) First Submission	1	1
	5	Commissioning and Performance Test Procedure manual		
		i) First Submission	1 set	--
		ii) Final Submission (Directly to site)	4 sets	2
TALCHER THERMAL POWER PROJECT STAGE-III (2X660 MW) EPC PACKAGE	TECHNICAL SPECIFICATIONS SECTION VI, PART-C BID DOC. NO.:CS-4540-001A-2	GENERAL TECHNICAL REQUIREMENTS Annexure-VI	PAGE 108 OF 114	

CLAUSE NO.	GENERAL TECHNICAL REQUIREMENTS (Annexure-VI)			एनटीपीसी NTPC
	S. No.	Description of Drgs./Docs.	No. of Prints	No. of Portable Hard Disk
	6	Performance and Functional Guarantee Test Report i) First Submission	2 sets	-
		ii) Approved Copies (Direct to Site)	4 sets	2
	7	Project Completion Report (Directly to site)	6 sets	2
TALCHER THERMAL POWER PROJECT STAGE-III (2X660 MW) EPC PACKAGE	TECHNICAL SPECIFICATIONS SECTION VI, PART-C BID DOC. NO.:CS-4540-001A-2	GENERAL TECHNICAL REQUIREMENTS Annexure-VI	PAGE 109 OF 114	

1236340/2023/PS-PEM-MAN



CORPORATE QUALITY ASSURANCE/ कॉरपोरेट गुणवत्ता आश्वासन
MAIN CONTRACTOR'S PROPOSAL CUM EVALUATION REPORT
मुख्य संविदाकार प्रस्ताव सह मुल्यांकन रिपोर्ट

Ref No: संदर्भ सं.:		Date: तिथि:	
i.	Main Contractor मुख्य संविदाकार		
ii.	Project परियोजना		
iii.	Package Name पैकेज का नाम	Package No पैकेज सं.	
iv.	Proposed Item/Scope of Sub-contracting उप-संविदा(अनुबंध) का प्रस्तावित मद/ दायरा		
v.	Item covered under निम्नलिखित के अंतर्गत शामिल मद	Schedule-1 /अनुसूची- 1	As per contract clause No- अनुबंध के अनुसार खंड सं.--
		Schedule-2 अनुसूची- -2	
vi.	<p>If item is Schedule-1 and proposed sub-vendor is indigenous, Main Contractor to explain how the contractual provisions will be fulfilled</p> <p>/यदि मद अनुसूची -1 है और प्रस्तावित उप-विक्रेता स्वदेशी है, तो मुख्य संविदाकार को स्पष्ट करना होगा कि संविदा/अनुबंध के प्रावधान कैसे पूरे किए जाएंगे</p>		
vii.	Name and Address of the proposed Sub-vendor's works /प्रस्तावित सब-वेंडर का नाम तथा पता		
viii.	PO placement date/ Start of manufacturing (if self-manufactured) as per L2 network पीओ नियोजन की तिथि / एल- 2 नेटवर्क के अनुसार विनिर्माण (यदि स्व-निर्मित है) की शुरुआत		
ix.	Item Description (Type/Size/Rating/Scope of Sub-Contracting) मद का विवरण (प्रकार / आकार / रेटिंग / उप-अनुबंध का दायरा)	Total quantity of proposed item envisaged in this package (Nos/ Running Meters/ Kgs/ Tons etc) इस पैकेज में परिकल्पित प्रस्तावित मद की कुल मात्रा (संख्या / क्रियाशील मीटर / किलोग्राम / टन आदि)	Quantity proposed to be procured from proposed sub-vendor (Nos/ Running Meters /Kgs /Tons etc) प्रस्तावित उप-विक्रेता (संख्या / क्रियाशील मीटर / किलोग्राम / टन आदि) से खरीदी जाने वाली मात्रा
			Timeline for quantity requirements as per project schedule & whether the proposed Sub-vendor equipped with adequate capacity to supply proposed order quantity in time / परियोजना समय सूची के अनुसार मात्रा आवश्यकताओं के लिए समय-सीमा और क्या प्रस्तावित उप-विक्रेता समय पर प्रस्तावित मांग की मात्रा की आपूर्ति करने में पूरी तरह से सक्षम है
x.	Supply experience of the proposed sub-vendor (including supplies to Main Contractor, if any) for similar item/scope of sub-contracting, for last 3 years (Note:- Only relevant experience details w.r.t. proposed item/scope of subcontracting to be brought out here) पिछले 3 वर्षों के लिए उप-अनुबंध के समान मद / दायरे के लिए प्रस्तावित सब-वेंडर (मुख्य संविदाकार हेतु		

1236340/2023/PS-PEM-MAN

एनटीपीसी
NTPC

CORPORATE QUALITY ASSURANCE/ कॉर्पोरेट गुणवत्ता आश्वासन
MAIN CONTRACTOR'S PROPOSAL CUM EVALUATION REPORT
मुख्य संविदाकार प्रस्ताव सह मुल्यांकन रिपोर्ट

आपूर्ति, यदि कोई हो, सहित) का आपूर्ति अनुभव (नोट: - उप-अनुबंध के प्रस्तावित मद / दायरे के संबंध में केवल प्रासंगिक अनुभव के विवरण का उल्लेख हो									
Project/Package परियोजना/पैकेज	Customer Name ग्राहक का नाम	Supplied Item (Type/Rating/Model /Capacity/Size etc) आपूर्ति मद (प्रकार/रेटिंग /माडल /क्षमता/आकार आदि)	PO ref no/date पीओ संदर्भ सं. /तिथि	Supplied Quantity आपूर्ति की मात्रा	Date of Supply आपूर्ति की तिथि				
<p><i>We confirm that as per our assessment, the proposed sub-vendor has requisite capabilities & supply experience and is suitable for supplying the proposed item/scope of sub-contracting/हम अपने आकलन के अनुसार इस बात की पुष्टि करते हैं कि, प्रस्तावित उप-विक्रेता के पास अपेक्षित क्षमता और आपूर्ति करने का अनुभव है और उप-अनुबंध के दायरे /प्रस्तावित मद की आपूर्ति के लिए उपयुक्त है।</i></p>									
Name: नाम:		Desig: पद:		Contact No: दूरभाष सं.:		Sign: हस्ताक्षर:		Date: तिथि:	

Company's Seal/Stamp:- कंपनी का मुहर:-



SUB-VENDOR QUESTIONNAIRE/ सब-वेंडर प्रश्नावली

i.	Item/Scope of Sub-contracting उप-संविदा(अनुबंध) का मद/ दायरा	
ii.	Address of the registered office पंजीकृत कार्यालय का पता	Details of Contact Person संपर्क व्यक्ति का विवरण (Name, Designation, Mobile, Email) (नाम, पदनाम, मोबाइल, ईमेल)
iii.	Name and Address of the proposed Sub-vendor's works where item is being manufactured प्रस्तावित उप-विक्रेता के कार्यों का नाम और पता, जहां मद का निर्माण किया जा रहा है	Details of Contact Person: संपर्क व्यक्ति का विवरण (Name, Designation, Mobile, Email) (नाम, पदनाम, मोबाइल, ईमेल)
iv.	Annual Production Capacity for proposed item/scope of sub-contracting उप-संविदा(अनुबंध) के प्रस्तावित मद / दायरे के लिए वार्षिक उत्पादन क्षमता	
v.	Annual production for last 3 years for proposed item/scope of sub-contracting उप-संविदा(अनुबंध) के प्रस्तावित मद / दायरे के लिए पिछले 3 वर्षों का वार्षिक उत्पादन	
vi.	Details of proposed works प्रस्तावित कार्यों का विवरण	
1.	Year of establishment of present works वर्तमान फैक्टरी की स्थापना का वर्ष	
2.	Year of commencement of manufacturing at above works उपरोक्त फैक्टरी में निर्माण कार्य शुरू होने का वर्ष	
3.	Details of change in Works address in past (if any) पूर्व में फैक्टरी स्थल में परिवर्तन का विवरण (यदि कोई हो)	
4.	Total Area कुल क्षेत्र	
	Covered Area शामिल क्षेत्र	
5.	Factory Registration Certificate फैक्टरी पंजीकरण प्रमाण पत्र	Details attached at Annexure – F2.1 विवरण अनुलग्नक- एफ 2.1 पर संलग्न है
6.	Design/ Research & development set-up डिजाइन / अनुसंधान और विकास सेटअप (No. of manpower, their qualification, machines & tools employed etc.) (श्रमिकों की संख्या, उनकी योग्यता, मशीन और उपलब्ध उपकरण आदि)	Applicable / Not applicable if manufacturing is as per Main Contractor/purchaser design Details attached at Annexure – F2.2 (if applicable) लागू / लागू नहीं, अगर विनिर्माण मुख्य संविदाकार / खरीददार के डिजाइन के अनुसार है। विवरण अनुलग्नक –एफ 2.2 पर संलग्न है। (यदि लागू हो)
7.	Overall organization Chart with Manpower Details (Design/Manufacturing/Quality etc) मैनपावर विवरण के साथ समग्र संगठन का चार्ट (डिजाइन / विनिर्माण / गुणवत्ता आदि)	Details attached at Annexure – F2.3 विवरण अनुलग्नक – F2.3 में संलग्न है।
8.	After sales service set up in India, in case of foreign sub-vendor(Location, Contact Person, Contact details etc.) भारत	Applicable / Not applicable लागू / लागू नहीं



SUB-VENDOR QUESTIONNAIRE/ सब-वेंडर प्रश्नावली

	में विक्री सेवा की स्थापना के बाद, विदेशी उप-विक्रेता के मामले में(स्थल , संपर्क व्यक्ति, संपर्क विवरण आदि)	<i>Details attached at Annexure – F2.4</i> विवरण अनुलग्नक -2.4 पर संलग्न है।			
9.	<i>Manufacturing process execution plan with flow chart indicating various stages of manufacturing from raw material to finished product including outsourced process, if any</i> फ्लोचार्ट सहित विनिर्माण प्रक्रिया निष्पादन योजना , जिसमें आउटसोर्स प्रक्रिया, यदि कोई हो, सहित कच्चे माल से तैयार उत्पाद तक विनिर्माण के विभिन्न चरणों को दर्शाया गया हो,	<i>Details attached at Annexure – F2.5</i> विवरण अनुलग्नक - F2.5में संलग्न है।			
10.	<i>Sources of Raw Material/Major Bought Out Item</i> कच्चे माल के स्रोत / खरीदे हुए मुख्य मद	<i>Details attached at Annexure – F2.6</i> विवरण अनुलग्नक - F2.6में संलग्न है।			
11.	<i>Quality Control exercised during receipt of raw material/BOI, in-process , Final Testing, packing</i> कच्चे माल / खरीदे हुए मद, प्रक्रियाबद्ध, अंतिम परीक्षण, पैकिंग करते समय गुणवत्ता नियंत्रण	<i>Details attached at Annexure – F2.7</i> विवरण अनुलग्नक - F2.7 पर संलग्न है			
12.	<i>Manufacturing facilities (List of machines, special process facilities, material handling etc.)</i> विनिर्माण सुविधा(मशीनों की सूची , विशेष प्रक्रिया सुविधाएं, सामग्री रख-रखाव आदि)	<i>Details attached at Annexure – F2.8</i> विवरण अनुलग्नक - F2.8में संलग्न है।			
13.	<i>Testing facilities (List of testing equipment)</i> परीक्षण सुविधाएं(परीक्षण उपकरण की सूची)	<i>Details attached at Annexure – F2.9</i> विवरण अनुलग्नक – F2. 9 में संलग्न है।			
14.	<i>If manufacturing process involves fabrication then-</i> यदि निर्माण प्रक्रिया में फेब्रिकेशन की गई है तो- <i>List of qualified Welders</i> पात्र वेल्डर की सूची <i>List of qualified NDT personnel with area of specialization</i> विशेषज्ञता के क्षेत्र सहित पात्र एनडीटी कार्मिकों की सूची	<i>Applicable / Not applicable</i> लागू / लागू नहीं <i>Details attached at Annexure – F2.10</i> विवरण अनुलग्नक - F2.10में संलग्न है। <i>(if applicable)</i> लागू / लागू नहीं			
15.	<i>List of out-sourced manufacturing processes with Sub-Vendors' names & addresses</i> सब-वेंडर द्वारा बाह्य स्रोतों (उनके नाम और पते सहित)से करवाएं गए निर्माण प्रक्रियाओं की सूची	<i>Applicable / Not applicable</i> लागू / लागू नहीं <i>Details attached at Annexure. –F2.11</i> विवरण अनुलग्नक - F2.10में संलग्न है। <i>(if applicable)</i> (यदि लागू हो)			
16.	<i>Supply reference list including recent supplies</i> नवीनतम आपूर्ति सहित आपूर्ति संदर्भ सूची	<i>Details attached at Annexure – F2.12</i> विवरण अनुलग्नक - F2.12 में संलग्न है। <i>(as per format given below)</i> (नीचे दिए गए प्रारूप के अनुसार)			
<i>Project/ package परियोजना /पैकेज</i>	<i>Customer Name</i> ग्राहक का नाम	<i>Supplied Item (Type/Rating/Model /Capacity/Size etc)</i> आपूर्ति की गई वस्तु (प्रकार / रेटिंग / मॉडल / क्षमता / आकार आदि)	<i>PO ref no/date</i> पीओ संदर्भ सं. / तिथि	<i>Supplied Quantity</i> आपूर्ति की मात्रा	<i>Date of Supply</i> आपूर्ति की तारीख
17.	<i>Product satisfactory performance feedback letter/certificates/End User Feedback</i> उत्पाद के संतोषजनक प्रदर्शन संबंधी फीडबैक पत्र / प्रमाण पत्र / अंतिम उपयोगकर्ता फीडबैक			<i>Attached at annexure - F2.13</i> अनुलग्नक F2. 3पर संलग्न है	
18.	<i>Summary of Type Test Report (Type Test Details, Report No, Agency, Date of testing) for the proposed product</i>			<i>Applicable / Not applicable</i> लागू / लागू नहीं	



SUB-VENDOR QUESTIONNAIRE/ सब-वेंडर प्रश्नावली

	(similar or higher rating) प्रस्तावित उत्पाद (एक समान या उच्च रेटिंग वाले) के लिए टाइप टेस्ट रिपोर्ट (टाइप टेस्ट विवरण, रिपोर्ट संख्या, एजेंसी, जांच की तारीख) का सारांश नोट: - रिपोर्ट प्रस्तुत करने की आवश्यकता नहीं है Note:- Reports need not to be submitted	Details attached at Annexure – F2.14 विवरण अनुलग्नक - F2.1 4में संलग्न है (if applicable) (यदि लागू हो)								
19.	Statutory / mandatory certification for the proposed product प्रस्तावित उत्पाद के लिए वैधानिक / अनिवार्य प्रमाणीकरण	Applicable / Not applicable लागू / लागू नहीं Details attached at Annexure – F2.15 (if applicable) (यदि लागू हो)								
20.	Copy of ISO 9001 certificate आईएसओ 9001 प्रमाण पत्र की प्रति (if available) (यदि उपलब्ध हो)	Attached at Annexure – F2.16 अनुलग्नक में संलग्न - F2.1 6 है								
21.	Product technical catalogues for proposed item (if available) प्रस्तावित मद के लिए उत्पाद तकनीकी कैटलॉग (यदि उपलब्ध हो)	Details attached at Annexure – F2.17 विवरण अनुलग्नक - F2.1 7 में संलग्न है								
<table border="1" style="width: 100%; border-collapse: collapse;"> <tr> <td style="width: 25%;">Name:</td> <td style="width: 25%;">Desig:</td> <td style="width: 25%;">Sign:</td> <td style="width: 25%;">Date:</td> </tr> <tr> <td>नाम:</td> <td>पद:</td> <td>हस्ता क्षर:</td> <td>तिथि:</td> </tr> </table>			Name:	Desig:	Sign:	Date:	नाम:	पद:	हस्ता क्षर:	तिथि:
Name:	Desig:	Sign:	Date:							
नाम:	पद:	हस्ता क्षर:	तिथि:							

Company's Seal/Stamp:- कंपनी की मुहर / मोहर: -



TITLE
2x660MW TALCHER TPP STAGE-III
DOUBLE GIRDER EOT CRANES ABOVE 100T
DOCUMENTS TO BE SUBMITTED ALONG WITH BID

SPECIFICATION NO. PE-TS-497-501-A501
REV 00
Section III Date DEC'22
Page 1 of 2

SECTION-III

DOCUMENTS TO BE SUBMITTED ALONG WITH BID



TITLE

2x660MW TALCHER TPP STAGE-III

DOUBLE GIRDER EOT CRANES ABOVE 100T

DOCUMENTS TO BE SUBMITTED ALONG WITH BID

SPECIFICATION NO. PE-TS-497-501-A501

REV 00

Section III Date DEC'22

Page 2 of 2

DRAWINGS / DOCUMENTS TO BE SUBMITTED WITH THE BID

Bidder shall submit the following drawings / documents along with their bid

- a) Signed and Stamped copy of Compliance cum Confirmation Certificate
- b) Electrical load list, duly signed and stamped
- c) Deviation schedule with reference to specific clauses of the specification along with reason for such deviation in the format given under Section-III
- d) Un priced copy of price format indicating quoted/ not applicable against each row/column

OFFER WILL BE CONSIDERED AS INCOMPLETE IN ABSENCE OF ANY OF ABOVE DOCUMENTS. DOCUMENT OTHER THAN ABOVE, IF ANY, SUBMITTED WITH THE OFFER WILL NOT FORM PART OF CONTRACT AND WILL NOT BE CONSIDERED FOR BID EVALUATION.



TITLE

2x660MW TALCHER TPP STAGE-III

DOUBLE GIRDER EOT CRANES ABOVE 100T

COMPLIANCE CUM CONFIRMATION CERTIFICATE

SPECIFICATION NO. PE-TS-497-501-A501

REV 00

Section III Date DEC'22

Page 1 of 2

COMPLIANCE CUM CONFIRMATION CERTIFICATE

The bidder shall confirm compliance with following by signing/ stamping this compliance certificate (every sheet) and furnish same with the offer.

- a) The scope of supply, technical details, construction features, design parameters etc. shall be as per technical specification & there are no exclusions other than those mentioned under "exclusion" and those resolved as per 'Schedule of Deviations', if applicable, with regard to same.
- b) There are no other deviations w.r.t. specifications other than those furnished in the 'Schedule of Deviations'. Any other deviation, stated or implied, taken elsewhere in the offer stands withdrawn unless specifically brought out in the 'Schedule of Deviations'.
- c) Bidder shall submit QP in the event of order based on the guidelines given in the specification & QP enclosed therein. QP will be subject to BHEL/ CUSTOMER approval & customer hold points for inspection/ testing shall be marked in the QP at the contract stage. Inspection/ testing shall be witnessed as per same apart from review of various test certificates/ Inspection records etc. This shall be within the contracted price with no extra implications to BHEL after award of the contract.
- d) All drawings/ data-sheets/ calculations etc. submitted along with the offer shall be considered for reference only, same shall be subject to BHEL/ CUSTOMER approval in the event of order.
- e) The offered materials shall be either equivalent or superior to those specified in the specification & shall meet the specified/ intended duty requirements. In case the material specified in the specifications is not compatible for intended duty requirements then same shall be resolved by the bidder with BHEL during the pre - bid discussions, otherwise BHEL/ Customer's decision shall be binding on the bidder whenever the deficiency is pointed out.

For components where materials are not specified, same shall be suitable for intended duty, all materials shall be subject to approval in the event of order.

- f) The commissioning spares shall be supplied on 'As Required Basis' & prices for same included in the base price itself.
- g) All sub vendors shall be subject to BHEL/ CUSTOMER approval in the event of order.
- h) The EQUIPMENT'S functional guarantees shall stand valid till at least eighteen (18) months from PERFORMANCE GUARANTEE test of equipment as per technical specification or commercial terms and conditions, whichever is later.
- i) In the event of order, all the material required for completing the job at site shall be supplied by the bidder within the ordered price even if the same are additional to approved billing break up, approved drawing or approved Bill of quantities. This clause will apply in case during site commissioning additional requirements emerges due to customer and/ or consultant's comments. No extra claims shall be put on this account.
- j) Schedule of drawings submissions, comment incorporations & approval shall be as stipulated in the specifications. The successful bidder shall depute his design personnel to BHEL's/ Customer's/ Consultant's office for across the table resolution of issues and to get documents approved in the stipulated time.



TITLE
2x660MW TALCHER TPP STAGE-III
DOUBLE GIRDER EOT CRANES ABOVE 100T
COMPLIANCE CUM CONFIRMATION CERTIFICATE

SPECIFICATION NO. PE-TS-497-501-A501
 REV 00
 Section III Date DEC'22
 Page 2 of 2

- k) As built drawings shall be submitted as and when required during the project execution.
- l) The bidder has not tempered with this compliance cum confirmation certificate and if at any stage any tempering in the signed copy of this document is noticed then same shall be treated as breach of contract and suitable actions shall be taken against the bidder.

1236340/2023/PS-PEM-MAX

LOAD TITLE	RATING (KW / A)		UNIT (U)/STN (S)	Nos.		VOLTAGE CODE*	FEEDER CODE**	EMER. LOAD (Y)	CONT.(C)/INTT.(I)	STARTING TIME >5 SEC (Y)	LOCATION	BOA RD NO.	CABLE		BLOCK CABLE DRG. No.	CONTROL CODE	REMARKS	LOAD No.
	NAME PLATE	MAX. CONT. DEMAND (MCR)		RUNNING	STANDBY								SIZE CODE	NOS				
1	2	3	4	5	6	7	8	9	10	11	12	13	14	15	16	17	18	19

TG HALL EOT CRANES			U	1	0	D	S	N	I		LOCATION OF CHANGE OVER SWITCH AT THE MID OF AB BAY AT 1500 mm from Operating Floor					VFD DRIVEN	Two supply feeders shall be provided up to isolating switches from each unit. One out of two feeders shall be in service at a time. Isolating cum Changeover switch shall be provisioned by vendor at indicated location.	
--------------------	--	--	---	---	---	---	---	---	---	--	--	--	--	--	--	---------------	--	--

NOTES: 1. COLUMN 1 TO 12 & 18 SHALL BE FILLED BY THE REQUISITIONER (ORIGINATING AGENCY); REMAINING COLUMNS ARE TO BE FILLED UP BY PEM (ELECTRICAL)
 2. ABBREVIATIONS : * VOLTAGE CODE (7):- (ac) A=11 KV, B=6.6 KV, C=3.3 KV, D=415 V, E=240 V (1 PH), F=110 V (cc): G=220 V, H=110 V, J=48 V, K=+24V, L=-24 V
 : ** FEEDER CODE (8):- U=UNIDIRECTIONAL STARTER, B=BI-DIRECTIONAL STARTER, S=SUPPLY FEEDER, D=SUPPLY FEEDER (CONTACTER CONTROLLED)

	LOAD DATA (ELECTRICAL)	JOB NO.	497	ORIGINATING AGENCY		PEM (ELECTRICAL)	
		PROJECT TITLE	2X660 MW TALCHER TPP	NAME		DATA FILLED UP ON	
		SYSTEM	TG HALL DG EOT Crane (ABOVE 100 T)	SIGN.		DATA ENTERED ON	
		DEPTT. / SECTION	MH Page 366 of 368	SHEET 1 OF 1	REV. 00	DE'S SIGN. & DATE	

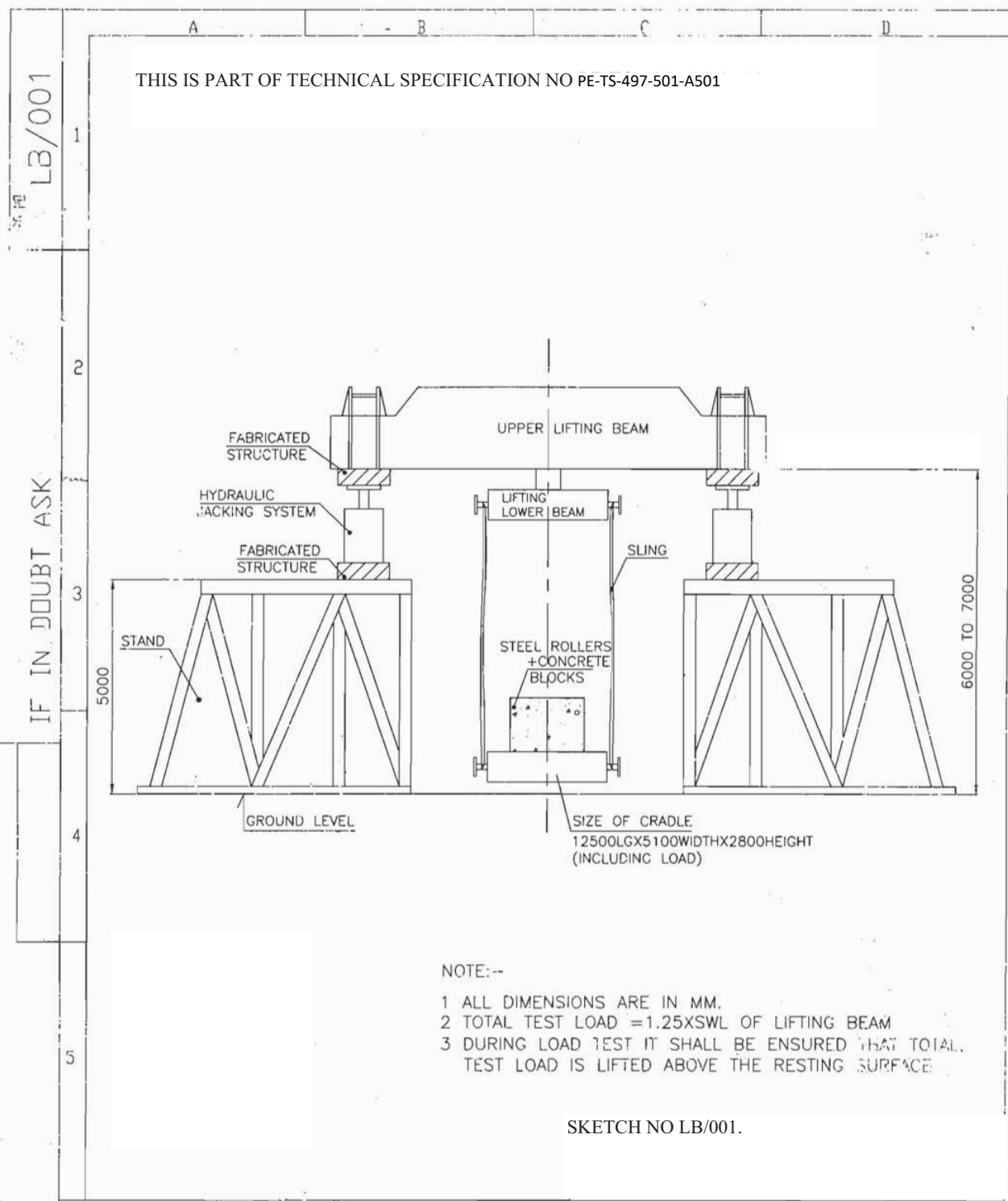

LB/001

IF IN DOUBT ASK

1

2

3

4

5

THIS IS PART OF TECHNICAL SPECIFICATION NO PE-TS-497-501-A501

NOTE:--
 1 ALL DIMENSIONS ARE IN MM.
 2 TOTAL TEST LOAD = 1.25XSWL OF LIFTING BEAM
 3 DURING LOAD TEST IT SHALL BE ENSURED THAT TOTAL TEST LOAD IS LIFTED ABOVE THE RESTING SURFACE.

SKETCH NO LB/001.

THIS DRAWING IS THE COPYRIGHT AND PROPERTY OF UNICOR AND MUST NOT BE COPIED, REPRODUCED OR SHOWN TO A THIRD PARTY WITHOUT THE WRITTEN CONSENT OF THE COMPANY.

Chandek 373

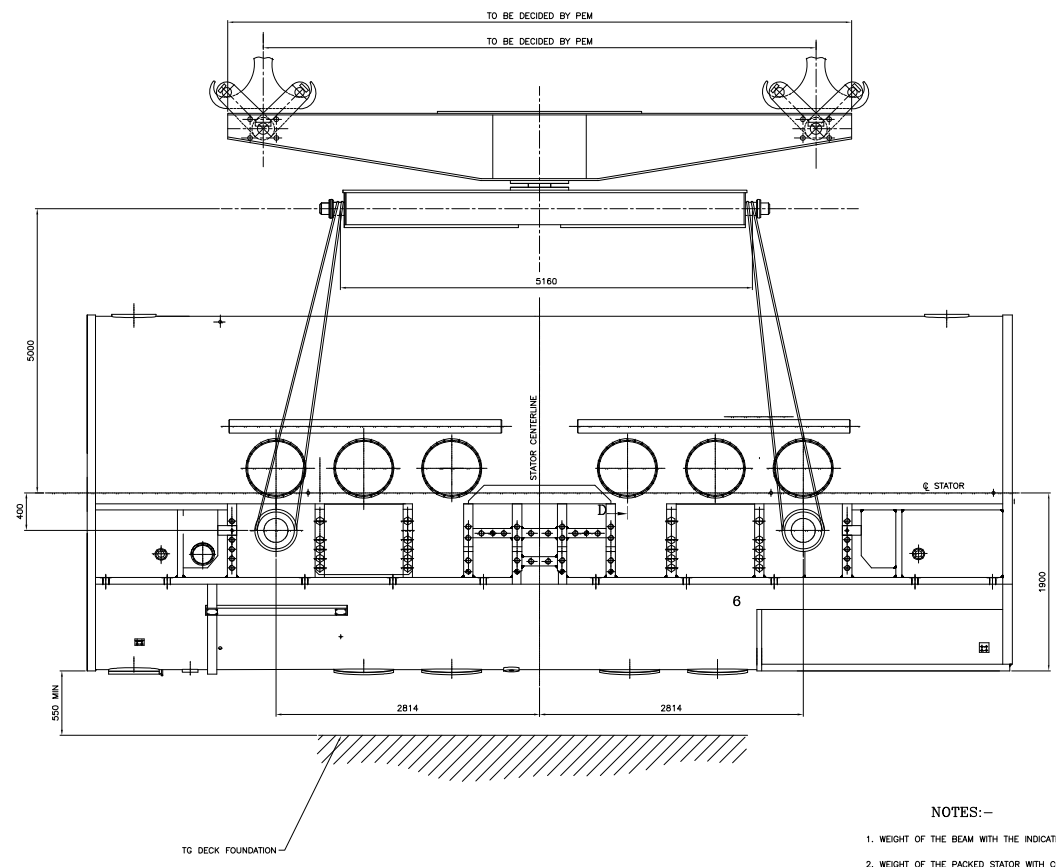

ENDLESS WIRE ROPE SLINGS
 SIZE=800A(MM)
 CLASS OF STEEL WIRE = 1770
 TYPE OF CONSTRUCTION = 6X36/6X41,
 WITH STEEL CORE
 CONFORMING TO = IS 2266-1989
 TABLE
 LENGTH OF SLINGS = TO SUIT THE
 INDICATED

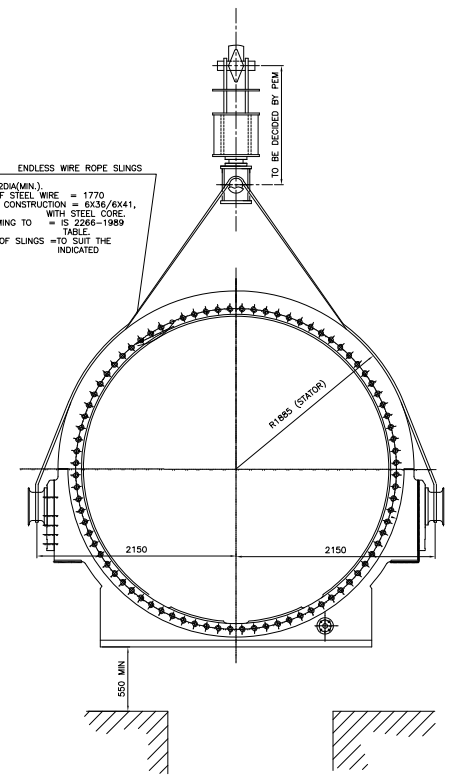

NOTES:-

1. WEIGHT OF THE BEAM WITH THE INDICATED ARRANGEMENT TO BE USED FOR DECIDING CRANE CAPACITY.
2. WEIGHT OF THE PACKED STATOR WITH COOLER HOUSING AND TERMINAL BUSHING BOX IS 326 TONNES.
3. DIFFERENCE IN THE LIFTS OF TWO CRANE AT ANY TIME SHOULD NOT EXCEED 200MM.
4. THE ARRANGEMENT SHOWN IN THIS SHEET IS FOR STATOR ALONE BROUGHT TO TG DECK TO BE PLACED ON PEDESTALS. FOR ASSEMBLY OF COOLER HOUSING AND TERMINAL BOX, AFTER ASSEMBLY ARRANGEMENT IS SHOWN IN SHEET-2 FOR LIFTING AND PLACING ON FOUNDATION.

TECHNICAL REQUIREMENTS

1. THE DETAIL OF LIFTING BEAM WITH SWIVELLING ARRANGEMENT INCLUDING MATERIAL IS TO BE DONE BY THE PEM, FOR A MAXIMUM LIFTING CAPACITY OF 326 TONNES.
2. THE LOAD TESTING SHALL BE CARRIED OUT BY THE PARTY, MIN. ACCEPTABLE LIMIT SHALL BE 25% OVER LOAD OVER THE RATED CAPACITY OF 326 TONNES.

Project: Tatar Thermal Power Project (020801000)
 ITRC Doc No: 4540-001-110-PVM-B-395 Rev 0
 Date: 09/06/2010 (DATE OF ISSUE)

CBOM NO.		SPEC. NO.		TYPE OF PRODUCT		600 / 660 MW GENERATOR	
DATE	NAME	SIGN.	DATE	NAME OF CUSTOMER/ PROJECT	NAME	SIGN.	DATE
GRADE OF UNTOL. DIM:-				M/CG- V/C/W/F AA 0230208			
WELDING- A/F/D/C/D- AA021104				MCH			
GAS CUTTING- TTA0021101				REF. TO ASSY. DRG.			
REV.	DATE	ALTERED	NO.	REV.	DATE	ALTERED	NO.
1		CHECKED		1		CHECKED	
DEPT.		SCALE		WEIGHT (K.g)		TITLE	
BHARAT HEAVY ELECTRICALS LTD.		1:1				LIFTING ARRANGEMENT FOR STATOR ALONE	
HARDWAR						DRAWING NO. IGE-2787	
						SHEET NO. 3	
						IND. OF SHEETS	
						SIZE A0	