

**GUIDELINES FOR SETTLEMENT OF CLAIMS FOR COMPENSATION ON ACCIDENTS
APPLICABLE TO BHARAT HEAVY ELECTRICALS LIMITED**

1. **Title:** These guidelines would be called as Guidelines for Settlement of Claims for Compensation arising out of accidents resulting into loss of life or permanent total disability.
2. **Effective date:** The guidelines would be effective from 10.09.2018.
3. **Applicability:** These guidelines would govern the settlement of compensation claims arising out of accidents resulting into loss of life or permanent disability.
4. **Definitions:**
 - a) **Accident:** Any death or permanent disability resulting solely and directly from any unintended and unforeseen injurious occurrence caused during the manufacturing/ operation and works incidental thereto at BHEL factories/ offices and precincts thereof, project execution, erection and commissioning, services, repairs and maintenance, trouble shooting, serving, overhaul, renovation and retrofitting, trial operation, performance guarantee testing undertaken by the company or during any works / during working at BHEL Units/ Offices/ townships and premises/ Project Sites.
 - b) **Competent Authority:** Competent Authority Means Chairman & Managing Director.
 - c) **Dependent:** As defined in the Employee's Compensation Act, 1923.
 - d) **Designated Officer:** An Officer designated by the company at Unit level for the purposes of receiving and processing claims for compensation under the present Guidelines.
 - e) **Victim:** Any person who suffers permanent disablement or dies in an accident as defined in these Guidelines.
 - f) **Permanent Disablement:** A disablement that is classified as a permanent total disablement under the proviso to Section 2 (l) of the Employee's Compensation Act, 1923.
5. **Detailed Accident Report:** The report prepared by the police within a period of 30 days from the date of incident as per Schedule I of this guidelines.

Explanation: For the purposes of the preparation of the detailed accident report, the word "injury" as referred in Schedule I refers to "Permanent disability" as mentioned in clause 4(f) of the Guidelines.

7/4

6. **Extent of Liability:** On the occurrence of any "accident" as defined under these Guidelines, the Company shall whether or not there has been any wrongful act, neglect or default on its part and notwithstanding anything contained in any other law, be liable to pay compensation in respect of each of the victims to such extent as prescribed below:

(i) In the event of death or permanent disability resulting from
Loss of both limbs: **Rs. 10,00,000/- (Rs. Ten Lakh)**

(ii) In the event of other permanent disability: **Rs.7,00,000/- (Rs. Seven Lakh)**

7. **Procedure for settlement of claims in respect of compensation**

a) The victim or his/her dependents would make an application within a period of 90 days of the accident to the Designated Officer under whose jurisdiction the accident had occurred. The application should be accompanied by the following documents:

- i. Proof of age of the victim
- ii. Death certificate of the victim

OR

Permanent disability certificate issued by the Medical Board authorized by the Government.

- iii. Certified copy of FIR lodged in respect of the accident.
- iv. Proof of applicant's relation with the victim/Dependency Certificate.

The Designated Officer may seek any further documents for settlement of claim to its satisfaction.

Provided that where there are more than one dependents, the Applicant must mention their name, addresses and relations with the victim and the Designated officer may at its own discretion issue notices to all dependents before releasing the compensation.

- b) The Designated Officer on receipt of above application shall take into consideration the Detailed Accident Report submitted by the Police Authority would process the claim of compensation on priority basis but would not take more than 30 days for disposing off the same in any case.
- c) The Designated Officer, in case where no application is received from the victim/dependents of victims, may on receipt of the detailed accident report proceed suo-moto to initiate the process for consideration for grant the compensation to the victim/dependents of victim.
- d) On issuance of guidelines, all contracts/agreement with contract value of ₹5,00,000 or above, which are entered into by the Company with any contractor, agency or firm for manufacturing/ operation and works incidental thereto at BHEL factories/ offices and precincts thereof, project execution, erection and commissioning, services, repairs and maintenance, trouble shooting, serving, overhaul, renovation and retrofitting, trial operation, performance guarantee testing etc. would invariably include a clause whereby any compensation paid under these

guidelines shall be recoverable from such contractor, agency or firm, if the accident is attributable to negligence of contractor, agency or firm or any of its employees.

In case the accident is not attributable to negligence of contractor, agency or firm or any of its employees, the same shall be paid by the Company with the approval of Unit Head (Not below ED/ GM I/C) and shall not be recoverable from contractor/ agency.

In the event that work / service contract etc. is of value being less than ₹5,00,000.00 or in case the works/ service contracts are executed by the Company directly and no third party i.e. contractor(s)/ service provider(s), is involved in the works/ service contracts being executed, the compensation under these guidelines, shall be paid by the Company, with the approval of the Head of Unit (Not below ED / GM I/C level).

In other accident cases arising out of works carried out for the company or carried out by the company itself but not covered under conditions as mentioned above, the compensation under these guidelines shall be paid by the company with the approval of Director (HR) & Director (Fin).

- e) In no case a claim for appointment of any of the dependents on the compassionate grounds would be entertained by the Company.

8. Method of Disbursement of compensation

- i. The amount of compensation so awarded shall be deposited in a Nationalized Bank or if the branch of a Nationalized Bank is not in existence, it shall be deposited in the branch of a scheduled commercial bank, in the joint or single name of the victim/dependent(s). Out of the amount so deposited, 75% (seventy-five percent) of the same shall be put in a fixed deposit for a minimum period of one year and the remaining 25% (twenty five percent) shall be available for utilization and initial expenses by the victim/dependent(s) as the case may be.
- ii. In the case of a minor, 75% of the amount of compensation so awarded shall be deposited in the fixed deposit account and shall be drawn only on attainment of the age of majority, but not before one year of the deposit. Provided that in exceptional cases, amounts may be withdrawn for educational or medical needs of the beneficiary at the discretion of the Company.
- iii. The interest on the sum shall be credited directly by the bank in the savings account of the victim dependent(s) on monthly basis.

9. **Appeal:** An appeal against the decision of the Designated Officer in respect of the amount of compensation or rejection of such claim shall be made to competent authority within a period of 30 days of such decision. The Competent Authority would decide the same within 30 days of receipt of such appeal.

Handwritten signature

SCHEDULE-I

PART – I – PARTICULARS OF THE ACCIDENT		
1.	FIR NO.-----, Dated and under Section	
2.	Name of Police Station	
3.	Date, Time, Place of the accident	
4.	Who reported the accident to the police	
5.	Name of the Person who took the victim to the hospital and Name of the Hospital	
6.	Whether any Hospital denied treatment to the Victim?	
7.	Nature of the accident:- (i) Whether resulted in death or injury or both? (ii) Number of persons injured/ died.	
8.	Name and Contact No. of the Investigating Officer	
9.	Name of the witnesses of the accident	
10.	Description of the accident	

7/4

PART II - IMPACT OF THE ACCIDENT ON THE VICTIMS

1.	<p>Death Cases: -</p> <ul style="list-style-type: none">a) Name and Address of the deceasedb) Agec) Genderd) Educatione) Occupationf) Income (Monthly)g) Legal Heirs / Guardian<ul style="list-style-type: none">i. Nameii. Relationshipiii. Ageiv. Addressv. Contact No.	
2.	<p>Injury Cases (permanent disablement)</p> <ul style="list-style-type: none">a) Name and address of the injuredb) Agec) Genderd) Educatione) Occupationf) Income (monthly)g) Details of family dependent of the victim MLC No.h) Nature of injuriesi) Name of Hospital where the injured treatedj) Whether victim refused medical treatment	

17/4

	<p>k) Period of hospitalization</p> <p>l) Period of treatment</p> <p>m) Whether treatment continuing</p> <p>n) Name, address and contact number of the doctor (s) who treated the injured</p> <p>o) Whether the injured underwent any surgery? If yes, then give particulars.</p> <p>p) Whether suffered any permanent disability</p> <p>q) Expenditure incurred on treatment conveyance, special diet, attendant etc. Give details, if available.</p> <p>r) Whether the injured got reimbursement of medical expenses from his employer or under a mediclaim policy. Give details, if available.</p> <p>s) Whether the injured was provided cashless treatment by the Insurance Company? Give details, if available.</p>	
3.	Any other relevant information.	

74

PART III - RELEVANT DOCUMENTS TO BE ATTACHED

1.	First Information Report	
2.	Photographs of the scene of the accident from all angles	
3.	Statement of the witnesses recorded by the Police.	
4.	Scientific report, if the Victim was under the influence of any liquor/drugs	
5.	<p>In case of Death:</p> <ul style="list-style-type: none">a) Post Mortem Reportb) Death Certificatec) Photograph and proof of the identity of the Deadd) Proof of legal representatives of the deceased.e) Photograph, specimen, signatures attested by the bank and identity proof of the legal representatives of the deceased.f) Treatment of the deceased with name and address of the Hospitalg) Bank account No. of the legal representatives of the deceased.	
6.	<p>In case of injury</p> <ul style="list-style-type: none">a) MLCb) Multi angled photographs of the injuredc) Photograph, specimen, signatures attested by the bank and identity proof of the injured.	

7/4

	d) Disability certificate	
7.	Any other relevant information.	

VERIFICATION

Verified at _____ on this _____ of _____ that the contents of the above report are true and correct and the documents mentioned in Part -III have been verified.

Station House Officer

Assistant Commissioner of Police

(Name and Stamp)

(Name and Stamp)

EIL/Owner may impose stoppage of work without any cost & time implication to the Owner and/or impose a suitable penalty.

The amount of penalty to be levied against defaulted Contractor shall be up to a cumulative limit of

2.0% (Two percent) of the contract value for Item Rate or Composite contracts with an overall ceiling of 1, 00, 00, 000 (Rupees One crore)

0.5% (Zero decimal five percent) of the contract value for LSTK, OBE, EPC, EPCC or Package contracts with an overall ceiling of 10, 00,00,000 (Rupees ten crores)

This penalty shall be in addition to all other penalties specified elsewhere in the contract. The decision of imposing stop-work-instruction and imposition of penalty shall rest with EIL/Owner. The same shall be binding on the Contractor. Imposition of penalty does not make the Contractor eligible to continue the work in unsafe manner.

The amount of penalty applicable for the Contractor on different types of HSE violations is specified below:

Sl. No.	Violation of HSE norms	Penalty Amount
1.	For not using personal protective equipment (Helmet, Shoes, Goggles, Gloves, Face shield, Boiler suit, etc.)	Rs.500/- per day/ Item / Person.
2.	Working without Work Permit/Clearance	Rs.20,000/- per occasion
3.	Execution of work without deployment of requisite field engineer / supervisor at work spot	Rs.5,000/- per violation per day
4.	Unsafe electrical practices (not installing ELCB, using poor joints of cables, using naked wire without top plug into socket, laying wire/cables on the roads, electrical jobs by incompetent person, etc.)	Rs.10,000/- per item per day.
5.	Working at height without full body harness, using non-standard/ rejected scaffolding and not arranging fall protection arrangement as required, like hand-rails, life-lines, Safety Nets etc.	Rs.10,000/- per case per day.
6.	Unsafe handling of compressed gas cylinders (No trolley, jubilee clips double gauge regulator, and not keeping cylinders vertical during storage/handling, not using safety cap of cylinder).	Rs.500/- per item per day.
7.	Use of domestic LPG for cutting purpose / not using flash back arresters on both the hoses/tubes on both ends.	Rs.3,000/- per occasion.
8.	No fencing/barricading of excavated areas / trenches.	Rs.3,000/- per occasion.
9.	Not providing shoring/strutting/proper slope and not keeping the excavated earth at least 1.5M away from excavated area.	Rs.5,000/- per occasion.
10.	Non display of scaffold tags, caution boards, list of hospitals, emergency services available at work locations.	Rs.1,000/- per occasion per day
11.	Traffic rules violations like over speeding of vehicles, rash driving, talking on mobile phones during vehicle driving, wrong parking, not using seat belts, vehicles not fitted with reverse horn / warning alarms / flicker lamps during foggy weather.	Rs.2,000/- per occasion per day

Sl. No.	Violation of HSE norms	Penalty Amount
12.	Absence of Contractor's RCM/ SIC or his nominated representative (prior approval must be taken for each meeting for nomination) from site HSE meetings whenever called by EIL/Owner & failure to nominate his immediate deputy (in the site-organogram) for such HSE meetings.	Rs.10,000/- per meeting.
13.	Failure to maintain HSE records by Contractor Safety personnel, in line with approved HSE Plan/Procedures/Contract specifications.	Rs.10,000/- per month.
14.	Failure to conduct daily site safety inspection (by Contractor's safety engineers/safety officers), internal HSE meeting, internal HSE Awareness/Motivation Program, Site HSE Training and HSE audit at predefined frequencies (as approved in HSE Plan).	Rs.10,000/- per occasion.
15.	Failure to submit the monthly HSE report by 5 th of subsequent month to Project's Engineer-in-Charge/ Owner	Rs.10,000/- per occasion and Rs. 1,000/- per day of further delay.
16.	Poor House Keeping	Rs.5,000/- per occasion per subject
17.	Failure to report & follow up accident (including Near Miss) reporting system within specific time-frame.	Rs.20,000/- per occasion
18.	Degradation of environment (not confining toxic spills, spilling oil/ lubricants onto ground)	Rs.10,000/- per occasion
19.	Not medically examining the workers before allowing them to work at height / to work in confined space / to work in shot-blasting / to work for painting / to work in bitumen or asphalt works, not providing ear muffs while allowing them to work in noise polluted areas, made them to work in air polluted areas without respiratory protective devices, etc.	Rs.5,000/- per occasion per worker
20.	Violation of any other safety condition as per job HSE plan / work permit and HSE conditions of contract (e.g. using crowbar on cable trenches, improper welding booth, not keeping fire extinguisher ready at hot work site, unsafe rigging practices, non-availability of First-Aid box at site, not providing dead man handle switch for blasting, whiplash arrestor for the compressor line, not using hood with respiratory devices by blaster for shot//grit blasting, etc.)	Rs.5,000/- per occasion
21.	Penalty for non-deployment of ambulance in case of man-power more than 400 or not providing dedicated emergency vehicle in case of man-power less than 400.	Rs.3,000/- per day
22.	Failure to carry-out Safety audit in time (internal & external), close-out of identified shortfalls of Observations of Safety Aspects(OSA), etc.	Rs.20,000/- per occasion
23.	Carrying out sand blasting instead of grit/shot blasting.	Rs.50,000/- per day

Sl. No.	Violation of HSE norms	Penalty Amount
24.	Failure to deploy adequately qualified and competent Safety Officer	Rs.10,000/- per day per Officer
25.	Utilization of hydra/back-hoe loader for material shifting or any other unauthorized /unsafe lifting works	Rs.25,000/- per occasion
26.	Any Fatal Accident	Rs.10,00,000/- per fatality
26.	Any violation not covered above	To be decided by EIL/Owner.

- The Contractor shall make his field engineers/supervisors fully aware of the fact that they keep track with the site workmen for their behavior and compliance of various HSE requirements. Safety lapses / defects of project construction site shall be attributable to the concerned job supervisor / engineer of the Contractor, (who remains directly responsible for safely executing field works). For repeated HSE violations, concerned job supervisor / engineer shall be reprimanded or appropriate action, as deemed fit, shall be initiated (with an information to EIL & Owner) by the concerned Contractor.

Contractor shall initiate verbal warning shall be given to the worker/employee during his first HSE violation. A written warning shall be issued on second violation and specific training shall be arranged / provided by the Contractor to enhance HSE awareness/skill including feedback on the mistakes/ flaws. Any further violation of HSE stipulations by the erring individuals shall call for his forthright debar from the specific construction site. A record of warnings for each worker/employee shall be maintained by the Contractor, like by punching their cards / Gate passes or by displaying their names at the Project entry gate. Warnings, penalizations, appreciations etc. shall be discussed in HSE Committee meetings by site Head of the Contractor.

3.1.14 Accident/ Incident investigation

All accidents/incidents shall be informed to EIL/Owner at least telephonically by Contractor immediately and in writing within 24 hours on Format No. HSE-2 as applicable, by Contractor. Thereafter, a Supplementary Accident/Incident investigation Report on Format No. HSE-3 shall be submitted to EIL/Owner within 72 hours. Near Miss incident(s), Dangerous accidents/incident shall also be reported on Format No. HSE-4 within 24 hours. The accident/incident shall be investigated by a team of Contractor's senior Site personnel (involving Site-in-Charge or at least by his deputy) for establishing root-cause and recommending corrective & preventive actions. Findings shall be documented and suitable actions taken to avoid recurrences shall be communicated to EIL/Owner. Owner/EIL shall have the liberty to independently investigate such occurrences and the Contractor shall extend all necessary help and cooperation in this regard. EIL/Owner shall have the right to share the content of this report with the outside world.





3.2 House Keeping

The Contractor shall ensure that a high degree of housekeeping is maintained and shall ensure inter-alia; the followings:

- All surplus earth and debris are removed/ disposed-off from the working areas to designated location(s).
- Unused/ surplus cables, steel items and steel scrap lying scattered at different places within the working areas are removed to identify location(s).
- All wooden scrap, empty wooden cable drums and other combustible packing materials, shall be removed from work place to identified location(s).

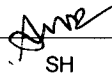
सीमेंट लाइन्ड पाइपिंग
हेतु
मानक विनिर्देश

STANDARD SPECIFICATION
FOR
CEMENT LINED PIPING

Rev. No	Date	Purpose	Prepared by	Checked by	Standards Committee Convenor	Standards Bureau Chairman
0	28.12.15	ISSUED AS STANDARD SPECIFICATION	 SH	 AK	 RN	 SC

Approved by

Abbreviations:

ANSI	:	American National Standards Institute
ASME	:	American Society of Mechanical Engineers
ASTM	:	American Society for Testing & Materials
AWWA	:	American Water Works Association
BS	:	British Standard
IS	:	Indian Standards
ISO	:	International Standards Organization
PMS	:	Piping Material Specification
SIS	:	Swedish Institute for Standards
SWG	:	Standard Wire Gauge

Piping Standards Committee

Convenor : Mr R. Nanda

Members : Mr M Ismaeel
Mr Amrendra Kumar
Mr G Balaji
Mr KJ Harinarayanan (SED)
Mr S Ghoshal (Process-2)
Mr G.K Iyer (Const.)
Mr KVK Naidu (Proj.)

CONTENTS

Sl.No	Description	Page No.
1.0	SCOPE	4
2.0	CODES & STANDARDS	4
3.0	MATERIALS	4
4.0	APPLICATION	5
5.0	CURING	6
6.0	PROCEDURE QUALIFICATION	6
7.0	INSPECTION DURING PRODUCTION	7
8.0	REPAIR OF LINING	7
9.0	PIPE JOINTS	8
10.0	FITTINGS & FLANGES	8
11.0	BRANCH CONNECTIONS	8
12.0	CUTTING METHODS OF CEMENT LINED PIPES	9
13.0	DAMAGE PROTECTION	9
14.0	INSTALLATION	9
FIGURE-01	CEMENT LINED PIPE: JOINTS & LINING THICKNESS	10
FIGURE-02	CEMENT LINED PIPE FITTINGS	11
FIGURE-03	CEMENT LINED PIPE BRANCHES	12
FIGURE-04	CEMENT LINED: BRANCHES FOR THERMOWELLS	13
FIGURE-05	CEMENT LINED: BRANCH FOR PRESSURE CONNECTION	14
FIGURE-06	CEMENT LINED VENT & DRAIN DETAILS	15
FIGURE-07	CEMENT LINED DETAILS FLANGED ENDS	16

1.0 SCOPE

This specification covers the minimum requirements of materials, mixing, application of cement lining, curing, inspection, repair, handling & transportation of piping system carrying sea-water, brackish water up to 70°C and 10.55 kg/cm²g (65°C & 16.0 kg/cm²g for fire water) pressure for piping systems 3" and above. The provisions of this specification are in addition to AWWA C205 and relevant piping material classes given in job PMS.

2.0 CODES & STANDARDS

ANSI / AWWA C205	:	Cement mortar protective lining and coating for steel water pipe-shop applied.
AWWA C602	:	Cement mortar lining of water pipelines in place.
ASME B31.3	:	Process Piping
ASTM C33	:	Standard Specification for Concrete Aggregates
ASTM A82	:	Specification for steel wire, plain, for concrete reinforcement
ASTM C150	:	Standard Specification for Portland Cement
ASTM A185	:	Specification for steel welded wire fabric, plain, for concrete reinforcement
ASTM C642	:	Standard Test Method for Density, Absorption and Voids in Hardened Concrete
BS 4232	:	British Standards institution- Surface Finish of Blast Cleaned Steel for Painting
IS 383	:	Specification for Coarse & fine aggregates from natural sources for Concrete
IS 456	:	Plain & reinforced Concrete- Code of practice
IS 4031	:	Methods of Physical Tests for Hydraulic cement
IS 6441	:	Methods of test for Autoclaved Cellular Concrete Products
IS 12330	:	Specification for Sulphate Resisting Portland Cement
ISO 8501-1 / SIS-055900	:	Preparation of Steel substrates before Application of Paints & Related Products

3.0 MATERIALS

3.1 Pipes & Piping Materials

Basic pipe fittings, flanges etc. shall be carbon steel and designed as per ASME B31.3 as per the relevant piping material classes given in job PMS for the project

3.2 Cements

Cement used in mortar lining shall be sulphate resistant as per ASTM C150 type-II or Portland cement conforming to IS 12330. Cement shall be free of lumps.

3.3 Sand

Sand shall consist of inert granular material and the grains shall be strong, durable and uncoated. Sand shall be clean and free from injurious amounts of dust, clay, flaky particles, oil, alkali, mica and other deleterious substances. Sand shall conform to IS 383 Grading zone III/ASTM C33.

3.4 Water

Water used for cement mortar mixing and curing shall be clean and free from injurious ingredients or organic matter, alkali, oil, acid, salt, sugar or other impurities and shall conform to IS 456. Salt water shall not be used for mixing under any circumstances.

3.5 Reinforcement

Reinforcement shall consist of welded steel wire fabric. Wires shall conform to ASTM A-82. Steel wires shall be galvanised at finished size. Wire fabric manufactured in flat sheets to ASTM A-185 shall be 2"x4" maximum steel wire mesh, with wire 12 SWG (2.6 mm minimum) each way.

4.0 APPLICATION

4.1 Cement Mortar Mixing

Cement lining shall be done in field shop, which may be outside the refinery boundary. Suitable mechanical equipment capable of mixing mortar and doing the lining work to a reasonable degree of uniformity w.r.t. thickness, density and strength shall be employed. Mortar shall be mixed in batches.

Mortar shall be composed of cement, sand and water and mixed well in proper consistency to obtain a dense, homogeneous lining that shall adhere firmly to the pipe surface. Cement mortar for lining shall consist of one part cement to not more than three parts sand by weight. Water to cement ratio shall be between 0.3 and 0.4 by volume.

Trial mixes shall be made to arrive at mix to achieve the requirements specified in procedure qualification clause 6.0.

4.2 Surface Preparation & Primer Application

Pipes shall be welded in suitable length and immediately prior to lining, the surface shall be thoroughly cleaned from inside removing all grease, scale, rust etc. by blast cleaning to Sa2 or by power tool to St.3 as per ISO 8501-1/SIS-05 5900/BS 4232. Surface cleaning shall be followed by spray application of welding grade of Inorganic Zinc Silicate prefabrication primer from approved paint manufacturers with a dry film thickness of 25 microns at both the pipe ends up to 100 mm pipe length. The cement lining shall be done at least after 10 Hours drying of the prefabrication primer to avoid damage of the primer.

4.3 Application of Reinforcement

Pipes & fittings in sizes 26" and above shall be cement lined with reinforcement. Wire fabric reinforcement shall be applied to the interior of pipes and fittings

Reinforcement shall be placed in the pipe in such a way as to cover the whole pipe length or sections to be lined. The reinforcement shall terminate at a distance of approx. 50mm from the ends. The reinforcement then shall be suitably tack welded. There shall be an overlap of minimum 25mm at the longitudinal joint of the reinforcement.

For the pipe butt joints, reinforcement in the form of strip approx. 150mm wide shall be placed and tack welded.

There shall be an overlap of minimum 25mm between two reinforcement sections.

4.4 Lining Application

The lining shall be applied in one course for the pipe section. No unfinished surface shall remain exposed for more than 20 minutes. Mortar shall be handled so as to avoid any kind of segregation and excessive moisture loss. During mortar application pipe should be at ambient temperature. If pipe is hot due to such reasons as lying in the hot sun, then the pipe must be

cooled with the help of wet gunny bags prior to application of mortar. Lining shall be free of any sharp corners and edges and must be suitably contoured/ rounded prior to curing.

For the lining at the joints of two pipes, reinforcement shall be applied as per 4.3 above. Old lining shall be suitably hacked to make it rough before filling mortar. Prior to mortar filling cement slurry may be applied on the surface.

Straight sections of pipe shall be lined by using spinning method or a method known to provide equivalent results such as by a machine traveling through the pipe and distributing the freshly mixed mortar uniformly along the full section and long radius bends of the pipe. The lining machine shall be provided with attachments for mechanically trowelling the mortar. Both the application and trowelling of the mortar shall take place at the rear of the machine so that the freshly placed and trowelled mortar will not be damaged. The trowel attachment, the rate of travel of machine and the rate of discharge of mortar shall be such that the pressure applied to the lining will be uniform and produce a lining of uniform thickness with a smooth, finished surface.

Hand patching at the end of the pipe, for length not more than 100mm length, shall be permitted to rectify the thinning of linings.

Fittings and specials shall be centrifugally spray lined to the same standard as straight pipes or, if this is precluded by their shape, by hand patched so as to achieve comparable results.

The thickness of lining shall be as per Figure-01. However to accommodate the disc movement of Butterfly valves the cement lining of the mating flanged spools shall be suitably tapered keeping minimum 3mm lining thickness.

5.0 CURING

After lining, the pipes shall be marked with the date of lining, **sealed with plastic caps** and shall be cured by moist curing as per AWWA C-205. Moist curing shall start after 24 hours of completion of cement lining and shall be done by continuous wetting or ponding. Under no circumstances the lining shall be allowed to dry during curing period. Curing shall be carried out for a minimum **Period of 7 days. Caps shall not be removed during the curing in order to protect the lining from drying out.**

6.0 PROCEDURE QUALIFICATION:

Prior to the application of the shop cement lining the manufacturer shall perform procedure tests and qualify a working procedure to demonstrate that he is able to produce a lining system in accordance with design requirement. The constituents, mortar & finished pipe shall be tested. To establish the correct combination of sand & water, minimum of five samples shall be prepared. For each mix following shall be accurately checked and recorded:

For Individual Constituents

- Cement/admixture
- Sand
- Water
- Proportions & weights of respective materials.

For Cement Mortar Test Specimen

- Density
- Compressive Strength
- Water absorption

Test blocks of this material when subjected to testing as per IS 6441/ IS 4031 shall exhibit compressive strength of not less than **316 kg/sq.cm.** after 28 days of curing and the density of cured lining shall not be less than 2300 kg/cu.m. Water absorption as per ASTM C 642 shall not exceed 10% for the test specimen. Based on the test results a procedure shall be standardised for mixing of the materials.

Inspection personnel shall witness the mixing of materials and sample preparations for procedure qualification. Test results shall be correlated with sample no. and a standard procedure shall be evolved.

7.0 INSPECTION DURING PRODUCTION

The entire procedure of applying cement-mortar lining shall be subjected to continuous inspection by Owner or their authorised representative. However, such inspection shall not relieve the contractor of the responsibility of meeting the specifications. The job shall be subjected to inspection at the following stages:

- i) After surface preparation and prior to application of lining.
- ii) After the application of reinforcement if any.
- iii) After application
- iv) After curing

Any lining not applied in accordance with this standard or not as per required thickness shall be subjected to rejection and replaced/repared at the expense of the contractor.

The inspector shall have free access to all areas and facilities concerned, and the contractor shall furnish all reasonable assistance.

The inspection of lining in pipe up to 24" dia shall be made from both ends of the lined pipe segment by using strong lights and/or mirrors. The inspection shall be done before the lining has attained its initial set. For pipes 26" & above, a manual, visual inspection of the lined pipe interior shall be made. Defects in cement-mortar lining include, but are not limited to, sand pockets, voids, over sanded areas, honey comb, excessively cracked, drummy areas, areas of lining thinner than specified, and areas of unsatisfactory surface finish.

The surface of lining shall be smooth and free from irregularities, cracks up to 0.8mm wide and not over 300mm in length are acceptable. Trough to crest height shall not exceed 1.0mm.

8.0 REPAIR OF LINING

8.1 For pipes up to 24" dia, the defective lining shall be removed in total from the pipe segment before the initial setting. The pipe segment shall then be relined in full compliance with the specifications.

8.2 For pipes above 24", small defective areas shall be repaired by manual removal of the defective lining and by hand reapplication of mortar lining. Defective areas encompassing the full dia of the pipe shall be replaced by machine wherever practical.

8.3 A pipe that has been exposed by spilling or cracking of the lining shall be cleaned thoroughly free from debris.

- 8.4 When an epoxy pipe-joining compound is to be used for the repair, the surface shall be dry and dust free and a coating of the compound shall be applied with a small trowel or spatula. When the cement mortar mix is to be used, the surfaces shall be dust free and moistened with clean fresh water. Immediately after moistening the cement-mortar mix shall be applied using a small trowel. If necessary a brush can be used for “feathering in” the surface edges of the repair.
- 8.5 Where cement-mortar is used for the repair, the adjacent lining shall be coated far enough back to cover any visible cracks and shall be maintained in a moist condition for three days using a wet hessian sack or similar means. Alternatively, if the line can be filled, it shall be put into use after the initial set has taken place.

9.0 PIPE JOINTING

Pipe joints both for above ground and underground piping up to sizes 48” shall be done by collars in general and by flanged fittings in specific cases wherever requirement arises for ease of fabrication, inspection and maintenance as per drawings. **Joints for sizes above 48” shall be butt welded.**

9.1 Jointing Methods:

- 9.1.1 Pipes, which have been cement-mortar lined shall not be butt welded together in the normal way as the mortar adjacent to the weld will be damaged by heat
- 9.1.2 For pipe size upto 48” diameter a uniformly applied layer of epoxy cement approx 1.6mm thick, shall be applied to both ends of the cement lining (and OD of the pipe and ID of the sleeve). Initial setting of epoxy cement must take place before the sleeve welding.
- 9.1.3 Pipe OD and sleeve ID shall be coated with **concrete joint coating – Two component solvent free Epoxy resin**. The sleeve welds should be located at 90 deg. clear of any longitudinal pipe weld.
- 9.1.4 Sleeves shall be welded using electrodes of dia less than 5mm. In the uphill technique care shall be taken that the lining, jointing and the coating are not damaged during welding (fit up and heat input)
- 9.1.5 The terminal ends shall be cut at right angles to the pipe axis and after completion of all welding out of roundness shall be within the limits specified by material code.

Pipes **above 48”**, shall be joined by butt welding and in-situ lining after welding. Refer Figure-01 for joint details.

10.0 FITTINGS & FLANGES

All fittings **up to 48” size** shall be generally collar joined with pipe. However flanged joints can be provided at critical locations for ease of fabrication, inspection and maintenance as per drawings. Flanges may be welded in field/shop prior to lining. Flange faces shall be free of cement lining. For detail refer Figure-02.

11.0 BRANCH CONNECTION

- 11.1 Branches in cement lined pipes shall be of minimum of 3” size. Stub in branch connections of size 3” onward shall be collar joined as per Figure-3A. However to meet specific requirement at critical locations for ease of fabrication, inspection and maintenance flanged joints may also be used as per Figure-3B.

11.2 Instruments branches for Temperature and Pressure instruments shall be as per figure-04 & 05. The 3" blind flange shall be drilled to suit inst./ vent/ drain size. The blind flange used for temperature connections shall be as per instruments standard. Blind flanges used shall be FRE lined on wetted parts (Refer Figures-05 & 06).

11.3 Vents and drains on cement lined piping shall be by 3" flanged stub with blind flange which is epoxy (FRE) lined on wetted parts. The blind flange shall be provided 3/4" tapped hole and 3/4" vent/ drain with valve & blind. Refer Figure-06 for details of vents & drains.

12.0 CUTTING METHODS OF CEMENT LINED PIPES

12.1 For cutting lined pipe, a splitter saw supported as necessary and containing a nylon bonded carborundum disc shall be used. Alternatively, a rigid pipe cutting machine using tungsten carbide tipped tools ground to the cutting angles.

12.2 On fusion welded steel pipes, the external weld shall be removed flush with, but not below, the face of the pipe for the width of the cutters, and if necessary for the complete width of the cutting machine.

12.3 The section to be removed and the adjacent pipe ends shall be suitably supported to avoid imposing any weight on the concrete lining when breaking through.

13.0 DAMAGE PROTECTION

13.1 Handling

Handling of lined pipe lengths shall be by means of nylon belts such that the pipes are supported 1/5 of their length from each end. Pipes shall not be lifted using hooks inserted in the pipe ends.

13.2 Transportation

13.2.1 Lined pipes being transported shall be adequately supported in a level horizontal position in order to minimize flexing and prevent induced bending and damage to the lining.

13.2.2 Pipes shall be protected from direct and indirect impact by means of suitable cushioning material.

13.2.3 During transportation and storage pipe lengths shall have end caps or other suitable means of protection, with sufficient holes to permit air circulation, provided this does not cause drying out and cracking of the lining. Means shall be taken to ensure that the end protection remains securely fastened, especially during transportation.

13.2.4 Branch connections shall be suitably plugged or capped as described above

14.0 INSTALLATION

14.1 Care shall be taken when handling jointed lengths of pipes to ensure that induced bending and the possibility of damage to the lining is minimized.

14.2 During pipeline installation, when handling, lifting and laying pipe, the spacing of lifting points and supports shall be adequate to avoid induced bending.

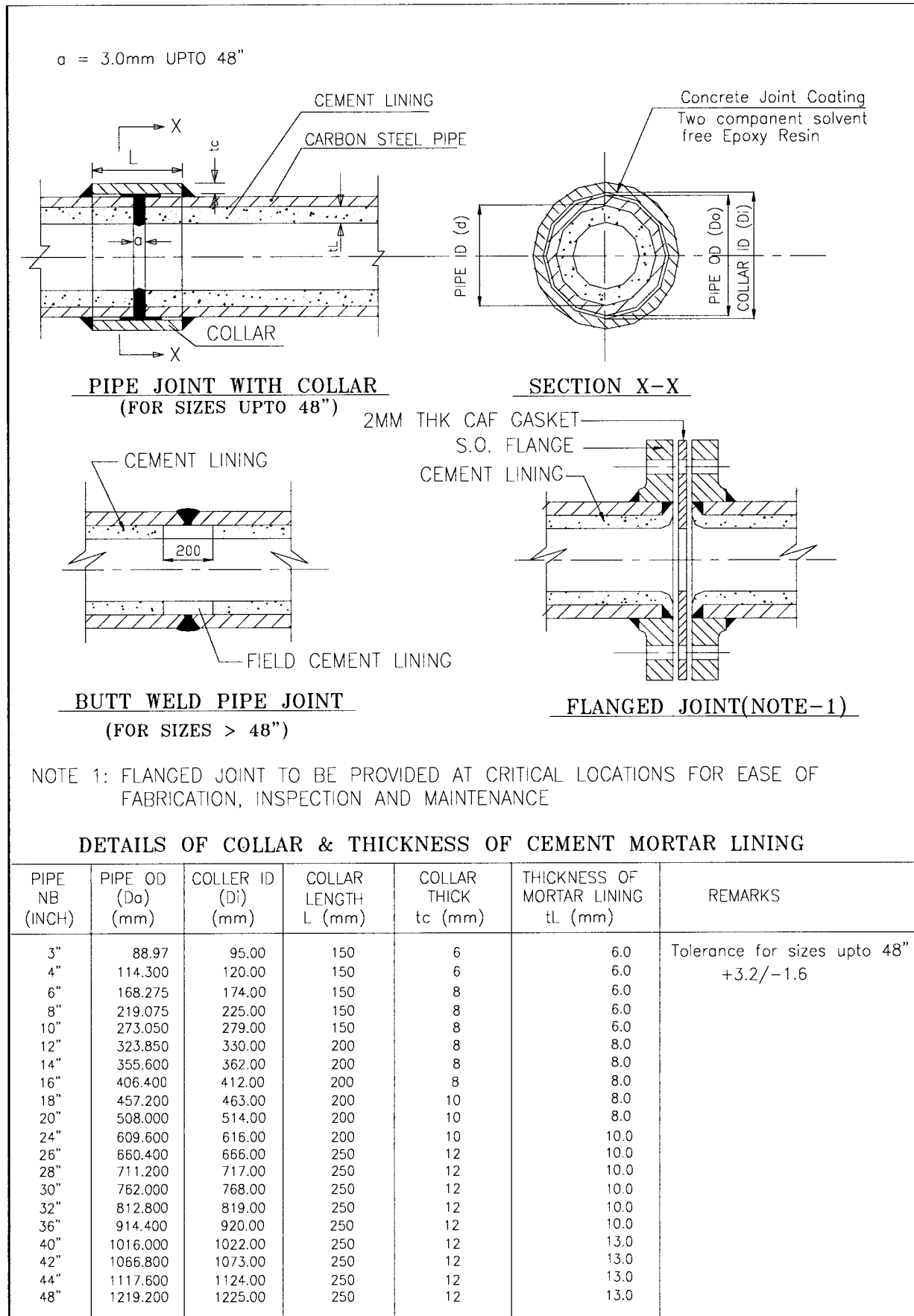

CEMENT LINED PIPES: JOINTS AND LINING THICKNESS (FIGURE-01)

NB (Inches)	a	b	c	d	R
	(All dimensions in mm)				
3"	264	201	236	389	114
4"	302	214	255	402	152
6"	379	245	293	440	229
8"	455	277	328	452	305
10"	531	309	366	478	381
12"	607	340	404	503	457
14"	683	372	430	630	533
16"	760	404	455	656	610
18"	836	436	493	681	686
20"	912	467	531	808	762
24"	1064	531	582	808	914
28"	1267	638	721	1010	1067
30"	1343	670	759	1010	1143
32"	1419	702	797	1010	1219
34"	1495	733	835	1010	1295
36"	1572	765	873	1010	1372
40"	1724	832	949	1010	1524
42"	1800	860	962	1010	1600
44"	1876	895	1013	1010	1676
46"	1953	927	1051	1111	1753
48"	2029	959	1089	1111	1829

NOTE 1. ALL FLANGES ARE 'SO' AS PER PIPING CLASS
 2. BASIC FITTING DIMENSIONS ARE AS PER ASTM B-16.9
 3. THIS TABLE DOES NOT COVER THE FABRICATED REDUCER AS PER EIL STD
 4. FOR FABRICATED FITTINGS OVERALL LENGTH SHALL BE CALCULATED AS FOLLOWS:
 LENGTH OF FABRICATED FITTINGS + SPOOL PIECE OF 150 MM UPTO 24"; 200 MM FOR 26"- 48" .

CEMENT LINED PIPE FITTINGS (FIGURE-02)

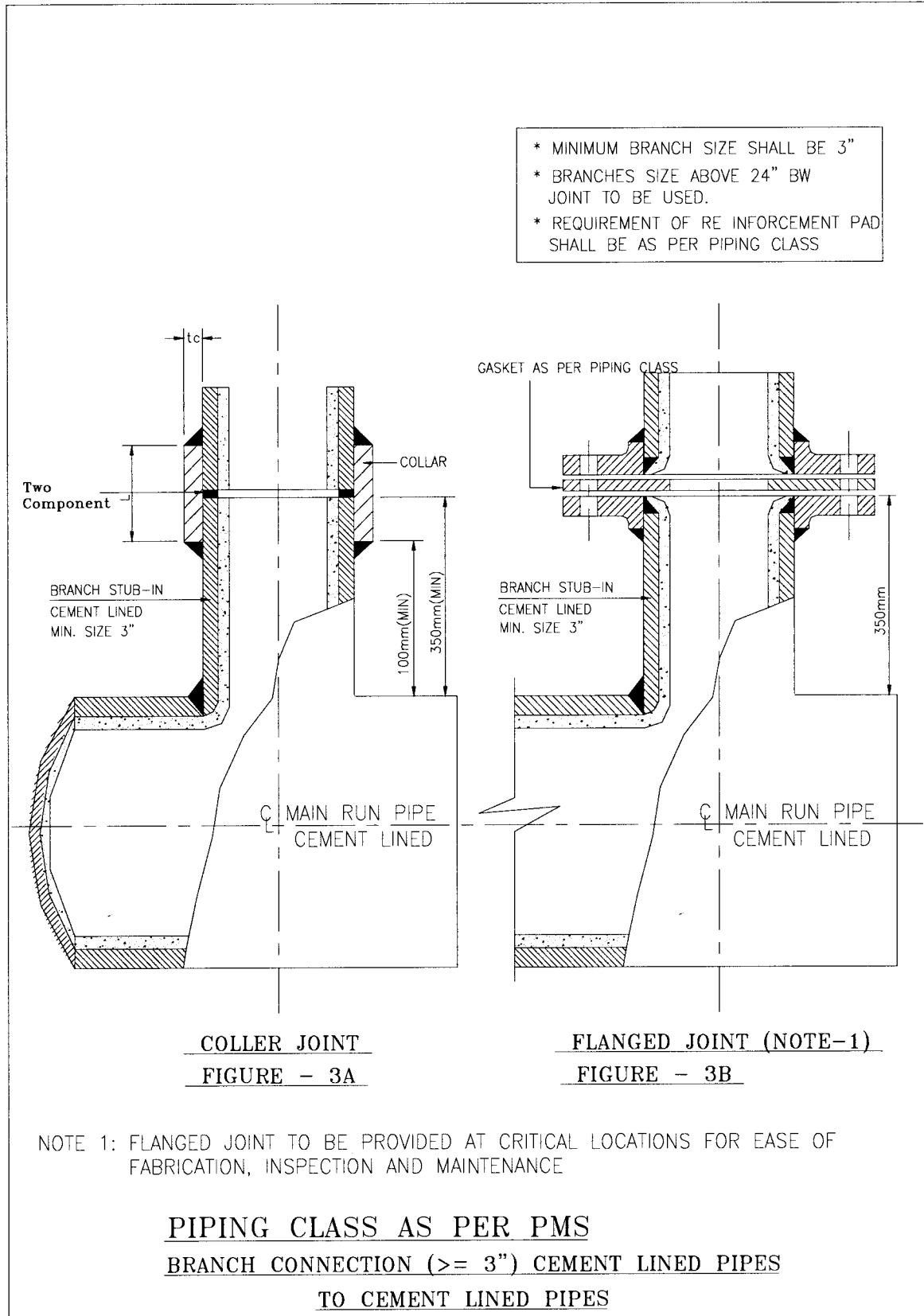

CEMENT LINED PIPE BRANCHES (FIGURE-03)

PIPE DIA.	FLANGED WELL "L" LENGTH
4"	250
6"	280
8"	280
10"	300
12"	300
14"	300
16"	350
18"	350
20" & ABOVE	400
VESSEL	AS REQD.

NOTES:--

1. ALL DIMENSIONS ARE IN mm, UNLESS OTHERWISE NOTED.

DETAIL OF INST. SCOPE ARE
INDICATIVE ONLY AND SHALL
BE AS PER INST. STD.

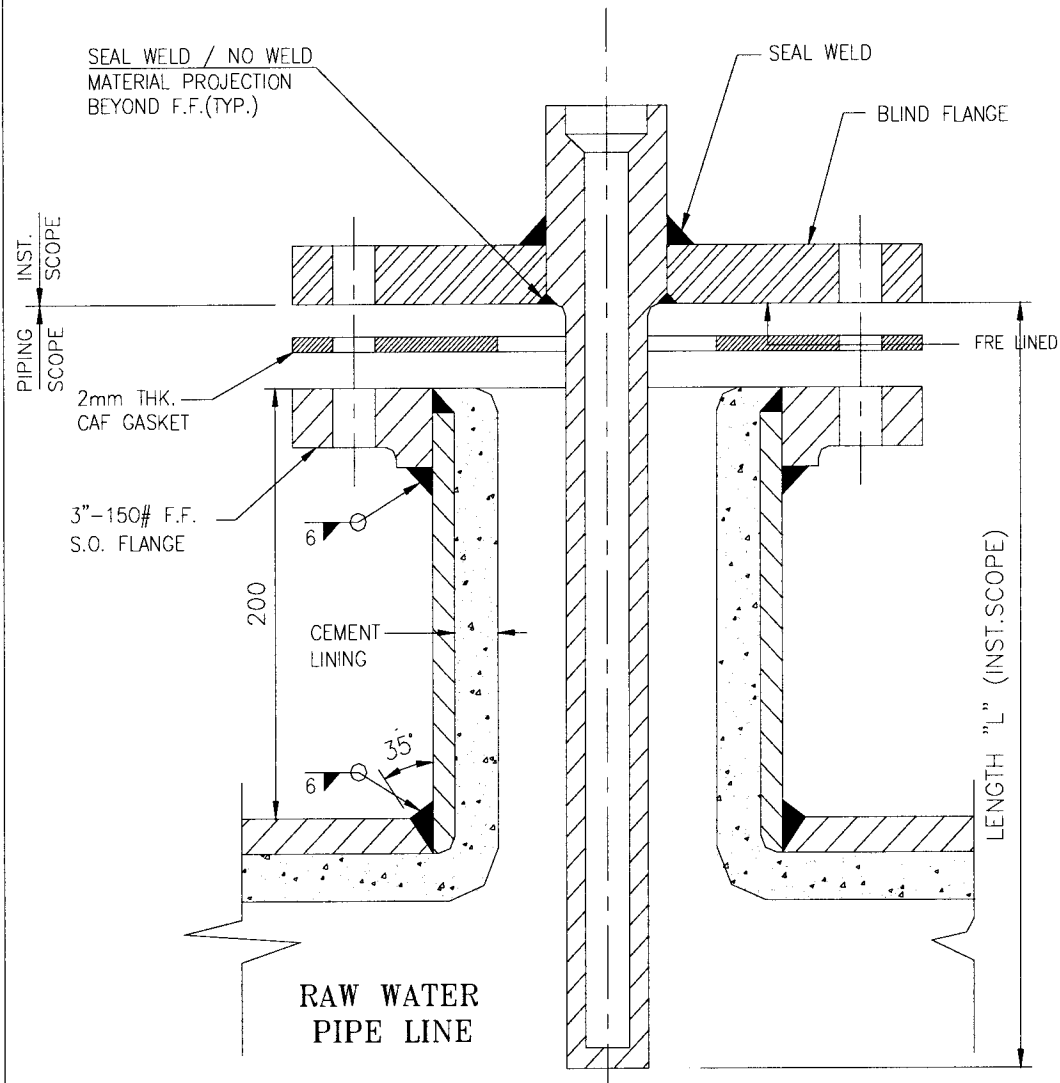

CEMENT LINED: BRANCH FOR THERMOWELLS (FIGURE-04)

NOTES:—

1. ALL DIMENSIONS ARE IN mm, UNLESS OTHERWISE NOTED.

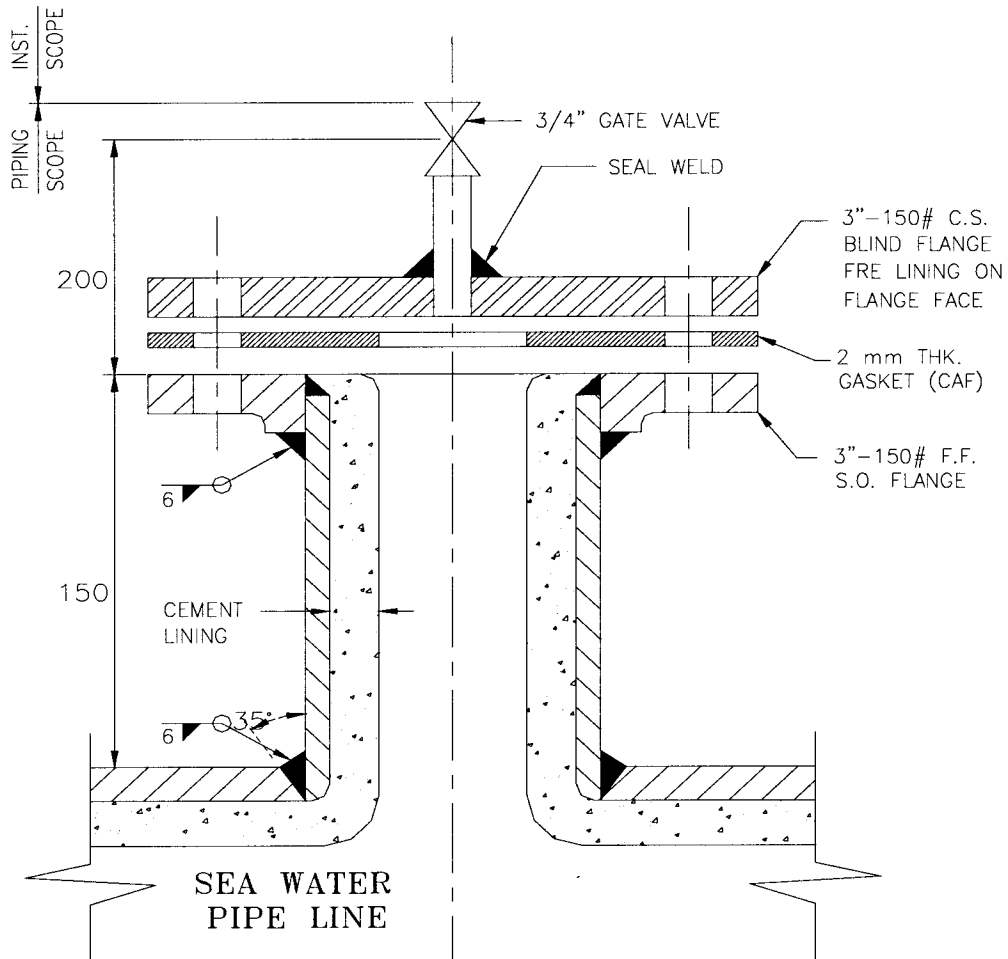

STD. FOR BRANCHES <3" AND PRESSURE INSTRUMENTS
FOR PIPING CLASSES AS PER PMS

CEMENT LINED: BRANCH FOR PRESSURE CONNECTION (FIGURE-05)

NOTES:-

1. ALL DIMENSIONS ARE IN mm, UNLESS OTHERWISE NOTED.

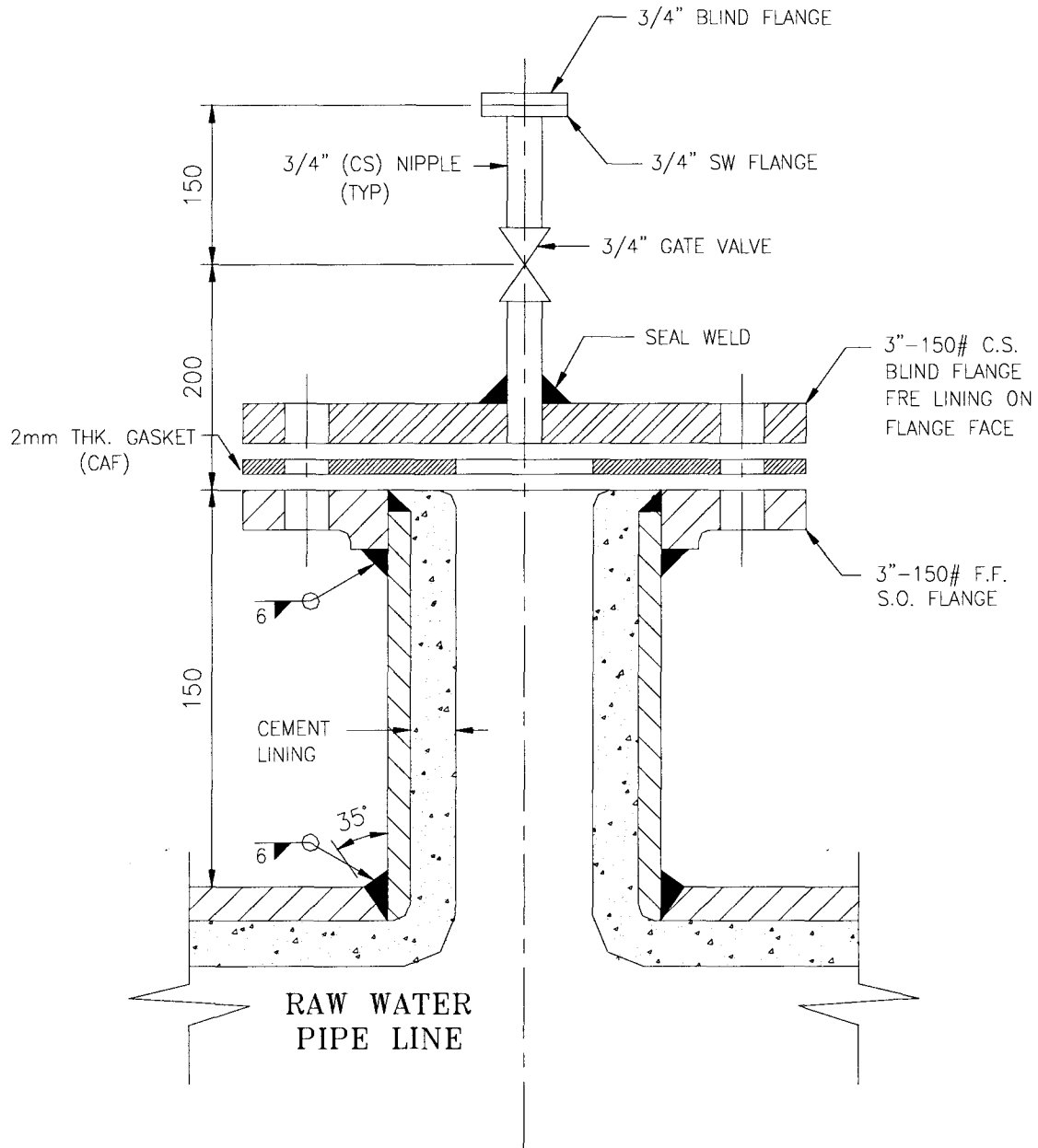

STD. FOR BRANCHES < 3" AND VENT / DRAIN (3/4")
MATERIAL AS PER PMS

CEMENT LINED VENT AND DRAIN DETAILS (FIGURE-06)

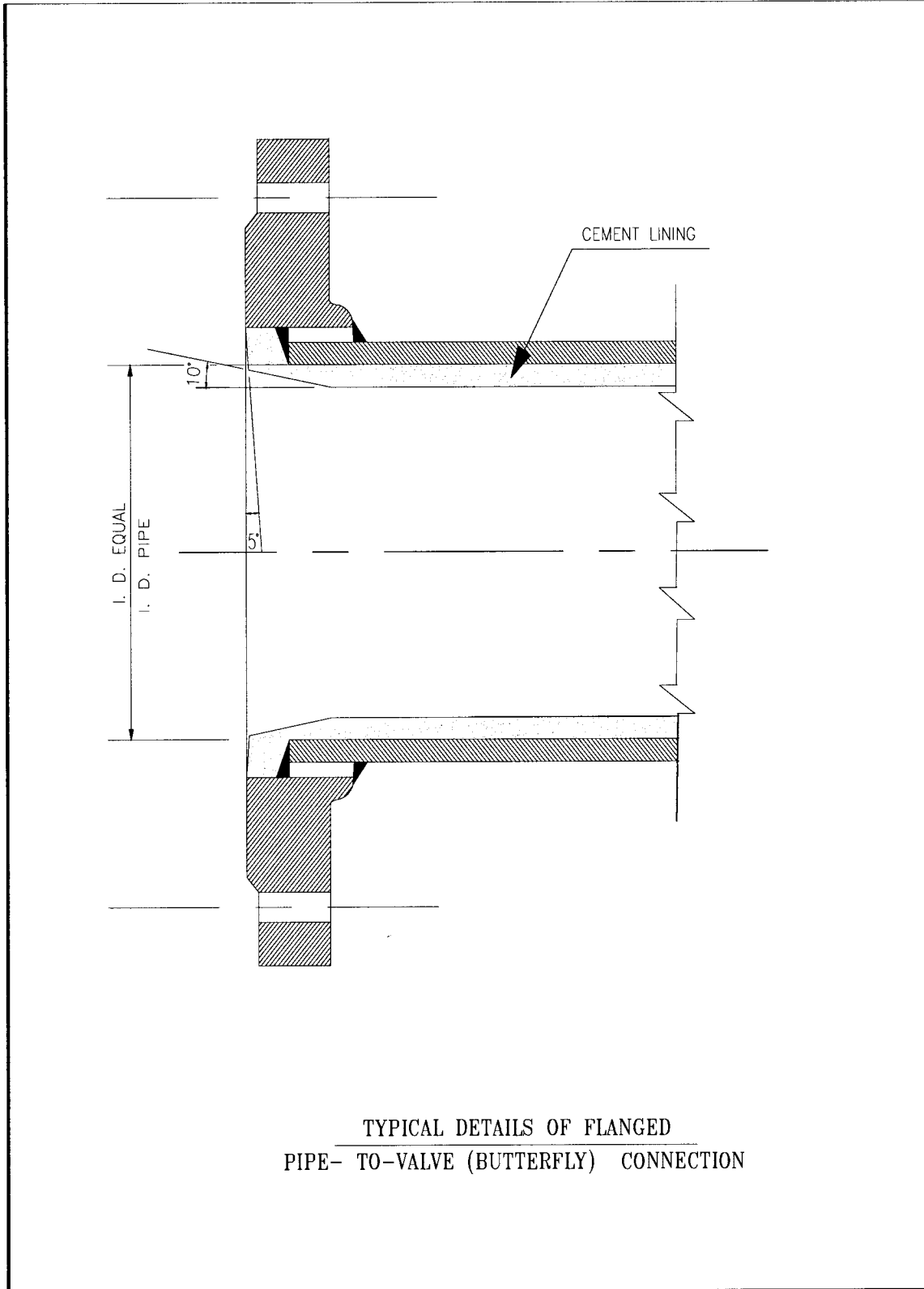

CEMENT LINED DETAILS FLANGED ENDS (FIGURE-07)

The Contractor shall minimize site works and prepare schemes for carrying out maximum works at vendor works and transport the equipments in sections.

Transportation of all completed sections, segments and equipment from shop to site and unloading the same at designated storage yard shall be in the scope of the contractor. All ODC equipments are to be transported by Hydraulic axles only. Contractor shall submit the detail report and Transportation Procedure after award of the job.

EPC Contractor shall implement following measures in view of constraints w.r.t limited space availability at project site-

- a) Maximize the pre-fabrication work for equipments at vendor works.
- b) Maximize simultaneous / parallel working on multiple fronts.
- c) Maximize work at ground to ensure good progress, quality, and safety.
- d) Erection of structures is to be planned in modular form.
- e) Erection of all columns, Vessels, Reactors etc. in dressed up conditions i.e. erection along with circular platforms, insulation (if applicable) and down comers.

Bidder shall visit the site at bid stage to acquaint himself with the site conditions at project site and furnish detail execution schedule and resource mobilization plan along with the offer to meet the Project schedule.

17.0 IMPLEMENTATION PLAN AND SITE REQUIREMENTS

• Piping Works

Use of commercially available Piping Construction management software by to be ensured by EPC Contractor so that accurate tracking and control can be exercised for piping works (Refer document No B016-00-000-19-41-1001).

Use of Digital radiography by EPC Contractor to the extent possible, which will provide Real time digital imaging and helps faster interpretation (Refer Doc. No. B016-00-000-19-41-1002). Use of Selenium based source for radiography to be implemented as per Instruction of Engineer-in-charge so that radiography can be done with minimum interference with other construction activities.

Use of Close Proximity & AUT (PAUT + TOFD) for major piping NDT. Contractor will be allowed to carry out Radiography with Close Proximity technique & AUT (PAUT + TOFD) Inside Refinery. However, in case Radiography with other technique is required to be carried out, same shall be done with prior approval of Engineer In-charge.

18.0 INTERFACE WITH OTHER CONTRACTORS

CONTRACTOR shall ensure that his interface with other CONTRACTORS is smooth and cordial. In case of any dispute, Owner/PMC decision shall be binding.

Owner/PMC may arrange weekly/fortnightly/monthly interface meetings. The CONTRACTOR shall depute concerned personnel to attend these meetings.

Generally, the following interfaces may be present:

- CONTRACTOR shall allow movement of persons/ material/ equipment/ vehicles belonging to other CONTRACTORS or Owner/PMC through the roads constructed by him.
- CONTRACTOR shall coordinate with 'neighboring' contractors for maintaining

4.1.6 Generation of reports in Microsoft word and excels formats.

5.0 SCOPE OF WORK AND GENERAL REQUIREMENTS

5.1.1 Refer Annexure-I for Scope and responsibility Matrix

5.1.2 **Methodology**

The contract shall have both computer radiography and conventional film Radiography at site. As per the directions/approval of Engineer-in-charge Conventional Radiography shall be implemented on following cases:

- To submit the Radiography films to Government Boiler Inspectorate
 - Radiography in case of failure of computer Radiography system.
 - Supplement to computer Radiography in case of shortage of films.

5.1.3 **Additional requirements**

- Sufficient quantity of suitable phosphor image plates, cassettes & adaptors based on peak load of project, Radiography for computer Radiography shall be kept ready.
- Film digitization unit for conventional film image storage.

5.1.4 Refer Annexure-II for bill of material of computer/digital Radiography.

5.1.5 Refer Annexure-III for technical specification of computer/digital Radiography.

5.1.6 **Reference documents:**

- ISO 17636-1:2013 Non-destructive testing of welds—Radiographic testing—part 1: X-ray and gamma ray techniques with film for pipeline girth weld.
- ISO 17636-2:2013 Non-destructive testing of welds —Radiographic testing—part 2: Digital Radiographic examination of fusion welded joints in metallic materials.

5.1.7 Contractor shall arrange their own scanners & suitable size image plates, cassettes and adaptors. Image plate sizes shall be as per weld joint size.

5.1.8 The radiography images to be taken by contractor in pen drive or CD for submitting/viewing at EIL on suitable monitor having at least 2 Megapixel resolutions.



VISAKH REFINERY MAINTENANCE DEPARTMENT	Doc. No. : DSI-G-1.2 Ref Doc : DSI-M-1 Rev. : 0 Date : December 2011 Page : Page 1 of 12
DEPARTMENTAL STANDING INSTRUCTIONS	
COLOUR CODE FOR REFINERY PLANTS (MECHANICAL SYSTEMS)	

1.0 OBJECTIVE :

- a. To specify the colour code for the Refinery Plant Systems in Onsite & Offsite areas
- b. The objective of colour code is to ensure clear identification of different process and mechanical systems.

2.0 SCOPE & APPLICABILITY

- a. The colour code covers refinery plant mechanical equipment like pipelines, supports, structurals, pumps, vessels, exchangers, columns, filters, valves, storage tanks and such mechanical systems.
- b. Identification labeling is part of this colour code.
- c. This colour code is applicable to all the existing Refinery Plants and systems in Onsite & Offsite areas.
- d. This colour code is limited to the mechanical systems only
- e. This colour code system is not applicable to
 - i) Civil cement masonry based structures
 - ii) Pipelines buried underground or submerged in water
 - iii) Internal painting
- f. This code does not envisage the specification of paint systems to be used

3.0 BASIS

This colour code is arrived at, after review of the following information and standards :

- a. HPCL-VR existing Colour Code
- b. EIL Colour code
- c. BP Colour Code.
- d. IS-2379: 1990 "Pipelines-Identification Colour Code"
- e. DHT Project colour coding.
- f. IS-5: 2007 for the purpose of Colour shade definition and identification.

4.0 RESPONSIBILITY

- a. Head-Maintenance is responsible to ensure that this colour code is implemented in the existing Plants & offsite areas
- b. Head-Operations is responsible to ensure awareness of this colour code among the operating personnel in all Plants.
- c. Head-Maintenance Offsites is responsible to ensure that the colour code remains up-to-date in line with the prevailing statutory and OISD provisions.



VISAKH REFINERY MAINTENANCE DEPARTMENT	Doc. No. : DSI-G-1.2 Ref Doc : DSI-M-1 Rev. : 0 Date : December 2011 Page : Page 2 of 12
DEPARTMENTAL STANDING INSTRUCTIONS	
COLOUR CODE FOR REFINERY PLANTS (MECHANICAL SYSTEMS)	

5.0 BASE COLOUR & IDENTIFICATION BANDS:

5.1 Pipe lines & Storage tanks:

5.1.1 Base Colour:

For Pipelines & storage tanks, a combination system of “Base Colour & Identification Banding-Stenciling” is followed.

Base colour shall be applied throughout the entire length & area of un-insulated pipes, equipment, storage tanks etc.

Base colour coating of minimum 2 meters length shall be applied on the following:

- a) metal cladding for insulated pipelines
- b) on the non ferrous & SS pipes and plastic pipelines

Valves (gate/ globe/ diaphragm/butterfly etc.) except control/safety valves, shall be painted with the same colour as the main pipe line colour.

5.1.2 Colour Bands:

Colour bands are superimposed on the base colour to distinguish:

- One kind or condition of a fluid from another kind or condition of the same fluid
- One fluid from another but belonging to the same group

The Base colour may be common to a group of fluids whereas the colour band is exclusive to the fluid handled in the Pipeline. This approach is adopted only for Pipelines & Storage tanks.

For the Pipelines, the width of color band shall conform to following:

Nominal Pipe Size	Width of the Band in mm
3” NB and below	75
Over 3” NB upto 4” NB	Nominal size x 25
Over 4” NB upto 12” OD	Nominal size x 50/3
Over 14” OD	Nominal size x 15



VISAKH REFINERY MAINTENANCE DEPARTMENT	Doc. No. : DSI-G-1.2 Ref Doc : DSI-M-1 Rev. : 0 Date : December 2011 Page : Page 3 of 12
DEPARTMENTAL STANDING INSTRUCTIONS	
COLOUR CODE FOR REFINERY PLANTS (MECHANICAL SYSTEMS)	

All uninsulated pipe lines having temperatures above 100 deg.C (Heat resistant aluminium painted) need not be identified with colour bands. As special case, if required, colour bands may be applied using Teflon tapes.

For insulated pipe lines, the nominal size means the outside diameter of insulation.

For storage tanks, the color bands (at three locations) shall be a min. of 500 mm width for tanks upto 30 mts. dia and 1000 mm for tanks above 30 mts. Dia. These bands shall be painted over the entire height of the shell from bottom prominently at three locations visible from the approach road.

5.1.3 Lettering :

In case of Pipelines, stenciling is additionally carried out in the immediate vicinity of the identification bands.

For the Pipelines, the size of lettering shall conform to following:

Outside Diameter of Pipe or Covering (mm)	Size of Letter (mm)
20 to 30	10
Above 30 to 50	20
Above 50 to 80	30
Above 80 to 150	40
Above 150 to 250	90
Over 250	110

5.1.4 Marking of Direction of Flow:

Flow direction shall be indicated by arrows or letters painted near valves, junctions, walls, etc., and at suitable intervals along the pipe, in a manner best suited to local conditions (refer the fig. below). The arrows shall be painted black or white in color and in contrast to the color on which they are superimposed.

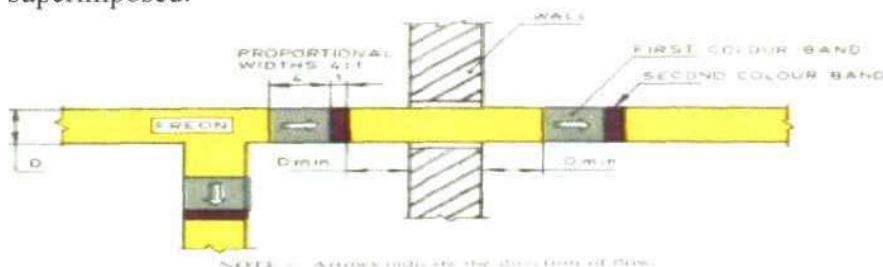



VISAKH REFINERY MAINTENANCE DEPARTMENT	Doc. No. : DSI-G-1.2 Ref Doc : DSI-M-1 Rev. : 0 Date : December 2011 Page : Page 4 of 12
DEPARTMENTAL STANDING INSTRUCTIONS	
COLOUR CODE FOR REFINERY PLANTS (MECHANICAL SYSTEMS)	

The size of arrow shall be as per the figure mentioned below. Product names shall be marked at pump inlet, outlet and battery limit in a suitable size

- a) 8" dia & below (fig 6A)
- b) above 8" dia size (fig. 6B)

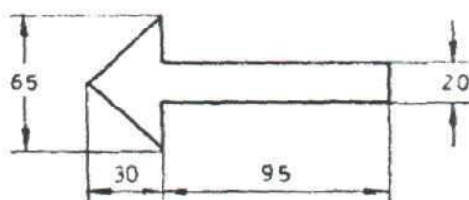

6A For Pipes DN 200 and Below

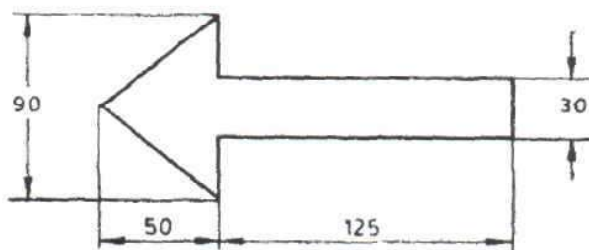

6B For Pipes Above DN 200

5.1.5 Visibility of Markings:

Attention shall be given to the visibility of color marking and the letterings. Where the pipelines are located above the normal line of vision of the operator, the lettering shall be placed below the horizontal line of the pipes, as shown in Figure below:

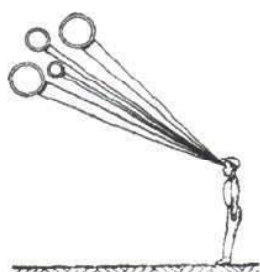



VISAKH REFINERY MAINTENANCE DEPARTMENT	Doc. No. : DSI-G-1.2 Ref Doc : DSI-M-1 Rev. : 0 Date : December 2011 Page : Page 5 of 12
DEPARTMENTAL STANDING INSTRUCTIONS	
COLOUR CODE FOR REFINERY PLANTS (MECHANICAL SYSTEMS)	

Preferably coloring shall be all around the pipe wherever possible, if not, the extent of coloring along the circumference is to be such that the colours and the markings are clearly visible.

The electrical illumination of plant in the night should be such that the shades of colors are not affected to ensure proper visibility in the night. Wherever legends and color bands are indicated, their location should be such that they are easily visible from floor/ground level during day time and extra illumination should be provided over them for night time or wherever visibility is poor.

Overhead pipe racks at road crossings shall be painted with zebra markings in yellow & black colour.

5.1.6 Locations for Marking Colour Bands

Base colour shall be applied throughout length of the piping whereas colour bands shall be applied at the following locations:

- At battery limit points
- At the intersection points and change of direction points in piping ways
- Other points such as mid-way of each piping ways, near valves, walls, either side of culverts/ road crossings
- For long stretch yard piping at 50m interval
- At start & terminating points
- Approaches, roads, overhead pipe rack crossings, stair case/monkey ladders

Flourescent bands on the pipelines are to be provided for night visibility for the locations such as overhead pipe racks at road crossings, stair cases, monkey ladders, wherever human interference is possible.

5.2 Equipment:

For equipment, general category items and miscellaneous items, only base colour is specified. No colour banding is required for this. Refer Table in Section 6.0 for base colour system for equipment.







Equipment number shall be stenciled in black and white on each vessel, heat exchanger, columns & machinery, after painting. Size of the letters printed for such purpose shall be 150 mm high for columns and vessels, 50 mm high for pump and other machinery.



VISAKH REFINERY MAINTENANCE DEPARTMENT	Doc. No. : DSI-G-1.2 Ref Doc : DSI-M-1 Rev. : 0 Date : December 2011 Page : Page 6 of 12
DEPARTMENTAL STANDING INSTRUCTIONS	
COLOUR CODE FOR REFINERY PLANTS (MECHANICAL SYSTEMS)	

6.0 COLOR SHADES

The following colour shades shall be used.

S. No	EQUIPMENT DESCRIPTION	BASE		BAND	
		COLOUR SHADE	No./shade per IS-5 (2007)	COLOUR SHADE	No. per IS-5 (2007)
A. GENERAL					
1.	-Technological Structure (columns/beams) -Equipment structural (columns/beams) -Technological structure Platforms, Equipment Platforms, Walk-ways -Pipe Supports -Spring supports -Monkey ladder rungs	Phirozi Blue	176 	--	--
2.	-Staircase side channels -Monkey ladder side beam/ Channel/ cage -Handrails, toe plates, etc.	Light Orange	557 	--	--
3	Overhead monorails	Signal Red	537 	--	--
4	Staircase steps	Dark Grey	632 	--	--
5	Chequered plates	Dark Grey	632 	--	--
6	Gratings	Galvanised	--	--	--
7	Davit supports	Phirozi Blue	176 	--	--
B. EQUIPMENT					
1	Heater	Aluminium		--	--



VISAKH REFINERY
MAINTENANCE DEPARTMENT

Doc. No. : DSI-G-1.2
Ref Doc : DSI-M-1
Rev. : 0
Date : December 2011
Page : Page 7 of 12

DEPARTMENTAL STANDING INSTRUCTIONS

COLOUR CODE FOR REFINERY PLANTS
(MECHANICAL SYSTEMS)









S. No	EQUIPMENT DESCRIPTION	BASE		BAND	
		COLOUR SHADE	No./shade per IS-5 (2007)	COLOUR SHADE	No. per IS-5 (2007)
2	HC Vessels/ Drums	Aluminium		--	--
3	Chemical drums	Golden Yellow	356	--	--
4	Acid drums/tanks	Pale cream	352	--	--
5	Columns	Aluminium		--	--
6	Boilers (Fired utility boilers/ CO boilers	Aluminium		--	--
7	Heat exchangers/ coolers/ condenser shells	Aluminium		--	--
8	HRSGs	Aluminium		--	--
9	Flue gas Stack	Black	--	--	--
10	Safety relief valves (PSV/TSV)	Satin blue	177	--	--
11	Control valves	Red/ Yellow/blue		--	--
12	Valves (gate, globe, diaphragm, butterfly etc)	Same as pipeline base colour	--	--	--
13	Drums	Aluminium		--	--
14	Pumps in HC service (operating temp. upto 100deg.C)	Brilliant green	221	--	--
15	Pumps in HC service (operating temp. above 100deg.C)	Aluminium		--	--
16	Pumps (acid/caustic/ chemicals)	Golden Yellow	356	--	--
17	Pumps (Water)	Phirozi	176	--	--

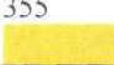

VISAKH REFINERY
MAINTENANCE DEPARTMENT

Doc. No. : DSI-G-1.2
Ref Doc : DSI-M-1
Rev. : 0
Date : December 2011
Page : Page 8 of 12

DEPARTMENTAL STANDING INSTRUCTIONS
COLOUR CODE FOR REFINERY PLANTS
(MECHANICAL SYSTEMS)

S. No	EQUIPMENT DESCRIPTION	BASE		BAND	
		COLOUR SHADE	No./shade per IS-5 (2007)	COLOUR SHADE	No. per IS-5 (2007)
		Blue			
18	Compressors, blowers, Ventilators, Vent silencers, ID fan/FD fan	Aluminium		--	--
19	Steam turbines	Aluminium		--	--
20	Motor, Switch gear, Machines	Silver grey	628 	--	--
21	Electrical Transformers			--	--
22	Fire proofing	Air craft grey	693 	--	--
23	Gas turbines	Aluminium		--	--
24	HC Storage tanks	White (reflective white for high vapour presure HC service)		Same as piping	--
C. PIPELINES					
AIR					
1	Instrument Air	White		Black	
2	Plant Air	White		--	--
3	Nitrogen	Lemon Yellow	355 	--	--
GASES					
1	LPG, Fuel Gas, Propylene	Aluminium		Signal Red	537 
2	Hydrogen	Lemon Yellow	355 	Fire Red	536 
3	Inert Gas / Nitrogen	Lemon	355	Phirozi	176













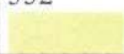

VISAKH REFINERY MAINTENANCE DEPARTMENT	Doc. No. : DSI-G-1.2 Ref Doc : DSI-M-1 Rev. : 0 Date : December 2011 Page : Page 9 of 12
DEPARTMENTAL STANDING INSTRUCTIONS	
COLOUR CODE FOR REFINERY PLANTS (MECHANICAL SYSTEMS)	

S. No	EQUIPMENT DESCRIPTION	BASE		BAND	
		COLOUR SHADE	No./shade per IS-5 (2007)	COLOUR SHADE	No. per IS-5 (2007)
		Yellow		Blue	
4	Sour Gas, Off Gas	Aluminium		Gulf Red	473 
5	Liquid Sulphur	Canary yellow	309 	--	--
6	Acid gas	International orange	592 	--	--
7	Flare gas	Aluminium		--	--
WATER					
1	Fire Water	Signal Red	537 	--	--
2	Sea Cooling Water	Sea Green	217 	--	--
3	DM water	Sky blue	101 	--	--
4	BFW	Sky blue	101 	Sea Green	217 
5	Condensate	Sky blue	101 	Canary yellow	309 
6	Fresh water / Service water	Phirozi Blue	176 	--	--
7	Drinking Water	Phirozi Blue	176 	Traffic yellow	368 
8	Tempered Water	Sky Blue	101 	Light Brown	410 
9	Bearing Cooling Water	Sky Blue	101 	Black	













VISAKH REFINERY MAINTENANCE DEPARTMENT	Doc. No. : DSI-G-1.2 Ref Doc : DSI-M-1 Rev. : 0 Date : December 2011 Page : Page 10 of 12
DEPARTMENTAL STANDING INSTRUCTIONS	
COLOUR CODE FOR REFINERY PLANTS (MECHANICAL SYSTEMS)	

S. No	EQUIPMENT DESCRIPTION	BASE		BAND	
		COLOUR SHADE	No./shade per IS-5 (2007)	COLOUR SHADE	No. per IS-5 (2007)
10	Sour Water/ Wash water	Light Brown	410 	--	--
STEAM					
1	VHP Steam	Aluminium		Post office red	538 
2	HP Steam	Aluminium		Light Orange	557 
3	MP Steam	Aluminium		Dark Violet	796 
4	LP Steam	Aluminium		Deep Buff	360 
ACIDS & CHEMICALS					
1	Caustic & Chemicals	Golden Yellow	356 	--	--
2	Acids	Pale cream	352 	--	--
HYDROCARBON					
1	Hydraulic & Lube Oil	Light Grey	631 	--	--
2	Cutter Stock	Aluminium		Opaline Green	275 
3	Naphtha (HN, SRN, CRN, NGL), MS	Aluminium		French Blue	166 
4	Kerosene, ATF, MTO	Aluminium		Lemon Yellow	355 
5	Diesel Oils (LDO, HDO)	Aluminium		Brilliant Green	221 
6	LGO, HGO, RCO, Circulating	Aluminium		Sea Green	217



VISAKH REFINERY MAINTENANCE DEPARTMENT	Doc. No. : DSI-G-1.2 Ref Doc : DSI-M-1 Rev. : 0 Date : December 2011 Page : Page 11 of 12
DEPARTMENTAL STANDING INSTRUCTIONS	
COLOUR CODE FOR REFINERY PLANTS (MECHANICAL SYSTEMS)	

S. No	EQUIPMENT DESCRIPTION	BASE		BAND	
		COLOUR SHADE	No./shade per IS-5 (2007)	COLOUR SHADE	No. per IS-5 (2007)
	Oil, VGO				
7	Vac. Resid, Bitumen, Fuel Oil, Clarified Oil	Aluminium		Black	
8	Slurry, Slop cut, Disulphate Oil	Aluminium		Light Grey	631 
9	Crude, Slop, Fuel Oil	Black		--	--
10	JBO / Ballast	Aluminium		--	--
D. MISCELLANEOUS					
1	Air Ducts	White		--	--
2	Air filters	White		--	--
3	Cable Trays (Power)	Sky Blue	101 	--	--
4	Cable trays (Inst.)	Brilliant Green	221 	--	--
5	Underground CBD routing	Traffic red	570 	--	--
6	Underground OWS routing	Satin Blue	177 	--	--
7	Underground ABD routing	International orange	592 	--	--
8	Underground CRW ETP	Light Olive green	278 	--	--
9	Emergency Light Fittings	Post Office Red	538 	--	--
10	General Light fittings	Dark Grey	632	--	--



VISAKH REFINERY MAINTENANCE DEPARTMENT	Doc. No. : DSI-G-1.2 Ref Doc : DSI-M-1 Rev. : 0 Date : December 2011 Page : Page 12 of 12
DEPARTMENTAL STANDING INSTRUCTIONS	
COLOUR CODE FOR REFINERY PLANTS (MECHANICAL SYSTEMS)	

S. No	EQUIPMENT DESCRIPTION	BASE		BAND	
		COLOUR SHADE	No./shade per IS-5 (2007)	COLOUR SHADE	No. per IS-5 (2007)

Notes:

- a) Heat resistant Aluminium shall be applied for piping/equipment as specified in the table for the services with temperature above 100 deg.C. Poly urethane (PU) aluminium shall be applied with temperatures below 100 deg.C.
- b) The colours indicated in the above table are indicative only. Adherence to the colours as per IS-5 shall be ensured.

7.0 APPROVAL & REVISION OF THIS GUIDELINE

- a. This guideline is controlled by Maintenance department.
- b. Head-Maintenance Offsites is responsible for monitoring various relevant OISD and other statutory standards concerning the required painting frequencies.
- c. Based on the information of any such statutory or OISD requirement, revision in this guideline should be proposed by the Head-Maintenance Offsites and approval to be obtained.

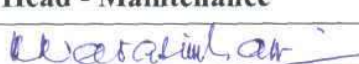
Administered by	Sign	
	Name	S Raja
	Designation	Head - Maintenance
Approved by	Sign	
	Name	V V R Narasimham
	Designation	GM – Operations