



ಭಾರತ್ ಹೆವಿ ಎಲೆಕ್ಟ್ರಿಕಲ್ಸ್ ಲಿಮಿಟೆಡ್
भारत हेवी इलेक्ट्रिकल्स लिमिटेड

Page 1 of 6

Bharat Heavy Electricals Ltd.,
(A Government of India undertaking)
Electronics Division

PB 2606 , Mysore Road Bangalore , 560026 INDIA

CE: PR: 003- Rev 02

SPECIAL COMMERCIAL CONDITIONS OF CONTRACT

Reference is brought to BHEL's Instructions to Bidders (Document Ref: CE: PR: 001- Rev 03) and General Commercial Conditions for Contract (Document Ref: CE: PR: 002- Rev 02).

These two documents along with Special Conditions of Contract annexed to this RFQ will form an integral part of the contract as and when the RFQ culminates into a Purchase Order / Contract.

RFQ No. : PVR0000244
RFQ Date : 01-08-2022
RFQ Due Date : 23-08-2022
Customer/Project : NPCIL - PCPTF, TARAPUR
Scope Description : LVS CONTROL PANEL FOR PCP TEST FACILITY

Kindly submit your quotation as **single/two/three part bid** (Pre-Qualification Criteria and Techno-Commercial bid - 1st part & Price bid - 2nd part) in E-Procurement System portal: <https://eprocurebhel.co.in> within the Due- Date of **23-08-2022** before **13.00** hours IST and note that tenders will be opened on the same day at **15.30** hours IST.

Purchase Executives: Clarifications with regard to the tender shall be addressed to purchase officers whose e-mail IDs are given below:

poojavrao@bhel.in or vijaykumarym@bhel.in

~~**Splitting of tendered quantity to MSE vendors:** The tendered quantity will be split to MSE vendor/s subject to submission of relevant document/s by vendors. Refer clause: I of Instructions to Bidders for conditions applicable and for information on document/s to be submitted. (Strike off, if not applicable)~~

Destination: For Indigenous scope of supply, items are to be directly despatched to BHEL site office/stores located at **BOISAR** in **MAHARASHTRA** state, India. Detailed Consignee details will be issued by BHEL along with Despatch Clearance.

Terms of Delivery:

- **Indigenous scope of supply:** Ex-works, <indicate station of dispatch> (including Packing & Forwarding charges but excluding Taxes).

- **Imported scope of supply:**

F.C.A. (for air consignments) < indicate international port of dispatch > / C.I.F. (for sea consignments) < ICD, Bangalore > (including Packing, Forwarding, Handling, Ancillary charges like processing of Sight Draft/ Letter of Credit, negotiation of bank documents, Export declaration, Country of Origin etc.).

Kindly indicate the approximate weight of the total imported consignment, which is required for calculating air-freight charges: _____

Under-mentioned details shall be provided against indigenous supplies & services:

- a. GSTIN of place of supply : _____
- b. HSN (Harmonized System of Nomenclature) code : _____
 Applicable tax and Rate : _____ & _____
- c. GSTIN of place of supply of service : _____
- d. SAC (Service Accounting Code) : _____
 Applicable tax and Rate : _____ & _____
- e. GeM Seller ID is mandatorily required for PO placement: _____
- f. If bidder is MSE vendor, are supporting documents enclosed: Yes /No
 (If MSE, supporting documents viz., Udyam certificate to be enclosed)

I. Bidders to mandatorily provide confirmation/compliance for the under-mentioned terms:

SL NO	TERMS	BHEL ACCEPTABLE TERM	BIDDER'S CONFIRMATION	REMARKS,if any
01	Reverse Auction (RA) <i>(strike off, if not applicable)</i>	BHEL shall be resorting to Reverse Auction (Guidelines as available on http://www.bhel.com/index.php/vender) for this tender. RA shall be conducted among all the techno-commercially qualified bidders. Price bids of all techno-commercially qualified bidders shall be opened and same shall be considered as initial bids of bidders in RA. In case any bidder(s) do(es) not participate in online Reverse Auction, their sealed envelope price bid along with applicable loading, if any, shall be considered for ranking.	AGREE	
02	Parting of license for imported raw materials <i>(strike off, if not applicable)</i>	In case of projects where Basic Custom Duty is NIL and vendor is importing any raw materials/ components for the enquired item, same are eligible for Zero Customs duty. As per EXIM policy, BHEL will part the import licence with the vendors to obtain import licence by themselves and custom clear the raw materials/ components by availing zero customs duty. Hence, please furnish list of raw materials/ components to be imported by you with Quantity and CIF value (for which BHEL has to share import licence). The benefit due to the above shall be passed on to BHEL and confirmed in the quotation. If there are no imported raw materials/ components, same shall be confirmed in the offer.	AGREE CIF value Yes, benefit passed on to BHEL in the priced quotation. (or) We confirm that there are no imported components	
03	Delivery Period	Within 10 weeks from the date of issue of Manufacturing clearance along with approved document. Delay in contractual delivery will attract Penalty as	AGREE weeks	

		per GCC Clause no.:04.b. Tentative delivery schedule: Nov 2022		
04	Terms of Payment at the time of material supply <i>(strike off, whichever is not applicable)</i>	Refer Clause "F" of Instructions to Bidder for BHEL standard Payment terms and loading factors applicable for non-compliance against payment terms: Indigenous Scope : a)Supply with Service(s) b)Supply only Imported Scope : c)Supply with Service(s) d)Supply only High-Sea sales : e)Supply with Service(s) f)Supply only Spares :- b) and/or d)/f) depending upon the scope	AGREE	
05	Declaration of local content : The 'Class-I local supplier'/'Class-II local supplier' shall be required to indicate percentage of local content and provide self-certification that the item offered meets the local content requirement for 'Class-I local supplier'/'Class-II local supplier', as the case may be.	'Local content' means the amount of value added in India which shall, unless otherwise prescribed by the Nodal Ministry, be the total value of the item procured (excluding net domestic indirect taxes) minus the value of imported content in the item (including all customs duties) as a proportion of the total value, in percent. {'Class-I local supplier' means a supplier or service provider, whose goods, services or works offered for procurement, has local content equal to or more than 50%, as defined under Public procurement order no.P-45021/2/2017-PP (BE-II) dt: 16.09.2020. 'Class-II local supplier' means a supplier or service provider, whose goods, services or works offered for procurement, has local content more than 20% but less than 50%, as defined under Public procurement order no.P-45021/2/2017-PP (BE-II) dt: 16.09.2020. In the event of any Nodal Ministry prescribing higher or lower margin of purchase preference and/or higher or lower percentage of local content in respect of this procurement, same shall be applicable}.' (Refer Clause 'A' Sl. No. 12 of Instructions to Bidders).	Percentage of local content : _____% Details of the Location(s) at which the local value addition is made : _____	
06	Declaration as a compliance to Rule 144(xi) of GFR, 2017 amendment dt 23.07.2020 issued by Ministry of	The below declaration is to be submitted on Company Letter head duly signed and sealed by authorised signatory, for ascertaining the eligibility of offer in the tender. "I have read the clause regarding restrictions on procurement from a bidder of a country which shares a land border with India; I certify that our firm is not from such a country or, if from such a		

	Finance, Govt. of India.	country, has been registered with the Competent Authority. I hereby certify that our firm fulfils all requirements in this regard and is eligible to be considered.” (Refer Clause ‘A’ Sl. No. 13 of Instructions to Bidders).		
--	--------------------------	---	--	--

II. Bidder to note that Deviations shall not be permitted for the below mentioned terms and are deemed to be complied. In case of non-compliance/deviation, offer shall be liable for rejection:

- (1) **Submission of documents post PO viz., drawings /data sheet etc. as indicated in Cl: 04 of GCC:** Within **02** weeks from the date of receipt of Purchase Order. Delay in submission of complete set of specified documents in NIT, will attract Penalty as per GCC Clause no.:04.a.
In case of any corrections in documents to be incorporated by seller for approval of document based on end-user/consultant/buyer comments, revised documents have to be submitted incorporating all corrections within 07 days. Seller shall be required to commence manufacturing only after receipt of approved documents.
- (2) **Validity:** The offer will be valid for a period of **75** days from the date of part-I bid opening and in case of Negotiation/ Counter-offer/RA, price validity will apply afresh for a period of **30** days from the date of according final price by bidder (or) up to original validity period, whichever is later.
- (3) **Warranty: 18** months from the date of supply of goods (or) **12** months from the date of commissioning, whichever is earlier. The seller should guarantee the rectification of goods in case of any break down during the Warranty period. Seller should have well established Installation, Commissioning, Training, Troubleshooting and Maintenance Service group in INDIA for attending the after sales service.
- (4) **Performance Bank Guarantee (PBG):** PBG will be applicable for a period of **18** months from the date of dispatch of goods + claim period of 03 months, for a value equal to 10% of the basic value of purchase order. It shall however be noted that PBG is not applicable against supply of Mandatory Spares.

Refer Clause “H” of Instructions to Bidders. Also note that PBG should be in the format specified in Annexure VII of ITB and no deviation to this format will be allowed.

Note: In case PBG is not furnished, the 10% basic amount will be withheld from the supply invoice. This withheld amount will be paid either against submission of supplementary invoice & Original PBG (or) against supplementary invoice without PBG after expiry of Warranty period.

- (5) **Despatch Documents:** Complete set of despatch documents (original + 1 photocopy set) as per Purchase Order shall be forwarded to Purchase Executive/BHEL directly. Depending upon the project/customer demands, Despatch documents may include one (or) more documents from the following:

Invoice (01 original and 01 copy with original sign & seal / digitally signed invoice), Lorry Receipt (L/R), Packing List, NIL Short-Shipment Certificate, insurance intimation letter, E-way bill, original Performance Bank Guarantee (directly from issuing bank to BHEL), Country of Origin certificate and original POD (Proof of Delivery) on L/R.

The precise list of despatch documents needed for the project will be specified in the Purchase Order.

One set of Invoice, Packing List, E-way bill (Part-A & B), Lorry Receipt (or) AWB/BOL shall be e-mailed immediately to BHEL-EDN at the time of despatch.

Note: Detailed Packing List should indicate package-wise content details and also Net & Gross weight of each package.

(6) **Freight Charges (for indigenous scope of supply):** Freight charges shall be to vendor's account. Bidder to quote reasonable Freight charges along with applicable tax, in price bid.

(7) **Evaluation criteria to determine L1 bidder:**

(a) ~~Item-wise evaluation of tendered item.~~

(or)

(b) Items will not be split on item-wise lowest offer. Evaluation of the lowest bidder will be done as a combined package basis.

Note:

1) Purchase preference to 'Micro and Small Enterprises' will get precedence over preference to 'Make in India' products.

2) Non-local offers i.e. other than Class-I offer & Class-II offer are also acceptable for this RFQ. However, purchase preference will be provided to Class-I offer only based on Government guidelines'

3) Purchase preference to Micro and Small Enterprises (MSEs): Purchase preference will be given to MSEs as defined in Public Procurement Policy for Micro and Small Enterprises (MSEs) Order, 2012 dated 23.03.2012 issued by Ministry of Micro, Small and Medium Enterprises and its subsequent Orders/Notifications issued by concerned Ministry. If the bidder wants to avail the Purchase preference, the bidder must be the manufacturer of the offered product in case of bid for supply of goods. Traders are excluded from the purview of Public Procurement Policy for Micro and Small Enterprises. Relevant documentary evidence in this regard shall be uploaded along with the bid in respect of the offered product. If L-1 is not an MSE and MSE Seller (s) has/have quoted price within L-1+ 15% of margin of purchase preference /price band defined in relevant policy, such Seller shall be given opportunity to match L-1 price and contract will be awarded for 100% of total value.

4) Preference to Make in India products: Preference shall be given to Class 1 local supplier as defined in public procurement (Preference to Make in India), Order 2017 as amended from time to time and its subsequent Orders/Notifications issued by concerned Nodal Ministry for specific Goods/Products. The minimum local content to qualify as a Class 1 local supplier is denoted above. If the bidder wants to avail the Purchase preference, the bidder must upload a certificate from the OEM regarding the percentage of the local content and the details of locations at which the local value addition is made along with their bid, failing which no purchase preference shall be granted. Default margin of purchase preference shall be 20% to local suppliers with default minimum local content of 50%.

~~(8) **Erection and Commissioning charges:** (strike off, if not applicable)~~

~~In case the quoted total E&C value is less than ___% of the main supply value, BHEL shall evaluate Bidders Price deducting differential amount from main supply price and apportioning towards E&C charges. Refer Sl. no. 'g' under Clause 'F' of Instructions to Bidders for Payment terms of E&C charges.~~

(9) **Erection Supervision and Commissioning charges:** (strike off, if not applicable)

In case the quoted total Erection Supervision & Commissioning value is less than 5% of the main supply value, BHEL shall evaluate Bidders Price deducting differential amount from main supply price and apportioning towards Erection Supervision & Commissioning charges.

Refer Sl. no. 'h' under Clause 'F' of Instructions to Bidders for Payment terms of Erection Supervision & Commissioning charges.

(10) Comprehensive Annual Maintenance Contract: *(strike off, if not applicable)*

CAMC will be applicable for a period of ___ years from the date of expiry of warranty period (or) from the date of completion of commissioning of equipment, whichever is later.

In case the quoted total CAMC value is less than ___% of the main supply value, BHEL shall evaluate Bidders Price deducting differential amount from main supply price and apportioning towards CAMC charges. It shall also be noted that year wise quote/ charges for CAMC should be either uniform (or) in increasing trend.

Refer Sl. no. 'i' under Clause 'F' of Instructions to Bidders for Payment terms of CAMC.

(11) Integrity Pact: *(strike off, if not applicable)*

Execution of Integrity Pact is applicable for this tender (Refer clause "K" of Instructions to Bidders). The IP as enclosed with the tender is to be submitted (duly signed by authorized signatory who signs in the offer) along with techno-commercial bid (Part-I, in case of two/three part bid). Only those Bidders who have entered into such an IP with BHEL would be competent to participate in the bidding. In other words, entering into this Pact would be a preliminary qualification.

(12) Consignee's right of rejection in respect of the goods finally received at his location shall in no way be limited or waived by reason of the goods having previously been inspected, tested and passed by Buyer/ Consignee or its Nominated External Inspection Agency prior to the goods' shipment.

With this, we hereby confirm that all the terms & conditions as indicated in Instructions to Bidders (Document Ref: CE: PR: 001- Rev 03) & General Commercial Conditions for Contract (Document Ref: CE: PR: 002- Rev 02) are accepted without any deviation.

Vendor's Signature with Seal

Note: The above filled-in document shall be furnished as a part of Techno-commercial bid (i.e. Part-I Bid).



ಭಾರತ್ ಹೆವಿ ಎಲೆಕ್ಟ್ರಿಕಲ್ಸ್ ಲಿಮಿಟೆಡ್
 भारत हेवी इलेक्ट्रिकल्स लिमिटेड

Bharat Heavy Electricals Ltd.,
(A Government of India undertaking)
Electronics Division

PB 2606 , Mysore Road Bangalore , 560026 INDIA

CE:PR:001- Rev 04

INSTRUCTIONS TO BIDDERS

Bidder is requested to read the instructions carefully and submit their quotation taking into consideration of all the points:

A. GENERAL INSTRUCTIONS:

1. Any Purchase Order resulting from this enquiry shall be governed by the Instructions to Bidders (document reference: CE: PR: 001 – Rev 03), General Conditions of Contract (document reference: CE: PR: 002 - Rev 02) and Special Conditions of Contract, if any, of the enquiry.
2. Any deviations from or additions to the “General Conditions of Contract” or “Special Conditions of Contract” require BHEL’s express written consent. The general terms of business or sale of the bidder shall not apply to this tender.
3. Regret letter (either through post or by mail or by EPS) indicating reasons for not quoting must be submitted without fail, in case of non-participation in this tender.

Supplier shall be liable for removal as a registered vendor of BHEL when the supplier fails to quote against four consecutive tender enquiries for the same item or all enquiries in last two years for the same item, whichever is earlier.

4. Procurement directly from the manufacturers is preferred. However, if the OEM/ Principal insist on engaging the services of an agent, such agent shall not be allowed to represent more than one manufacturer/ supplier in the same tender.

Moreover, either the agent could bid on behalf of the manufacturer/ supplier or the manufacturer/ supplier could bid directly but not both. Agent/Representative authorized by the OEM/Principal in turn cannot further sub authorize any other firm for submitting the offer or for placement of order.

In case bids are received from the manufacturer/ supplier and his agent, bid received from the agent shall be ignored.

5. Consultant / firm (and any of its affiliates) shall not be eligible to participate in the tender/s for the related goods for the same project if they were engaged for consultancy services for the same project.
6. If an Indian representative/associate/liaison office quotes on behalf of a foreign based bidder, such representative shall furnish the following documents:
 - a. Authorization letter to quote and negotiate on behalf of such foreign-based bidder.
 - b. Undertaking from such foreign based bidder that such contract will be honored and executed according to agreed scope of supply and commercial terms and conditions.
 - c. Undertaking shall be furnished by the Indian representative stating that the co-ordination and smooth execution of the contract and settlement of shortages/damages/replacement/repair of imported scope

till the equipment is commissioned and handed over to customer will be the sole responsibility of the Indian representative/associates/agent/liaison office.

d. Refer **Annexure I** on “Guidelines for Indian Agents”.

7. In case of imported scope of supply, customs clearance & customs duty payment will be to BHEL account after the consignment is received at Indian Airport /Seaport. Bidders must provide all original documents required for completing the customs clearance along with the shipment.

Warehousing charges due to incomplete or missing documentation will be to supplier’s account. All offers for imported scope of supply by air, must be made from any of the gateway ports (within the country) indicated **(Refer Annexure II)**.

8. The offers of the bidders who are on the banned list and also the offers of the bidders, who engage the services of the banned firms, shall be rejected. The list of the banned firms is available on BHEL website: http://www.bhel.com/vender_registration/vender.php
9. Business dealings with bidders will be suspended if they are found to have indulged in any malpractices/misconduct which are contrary to business ethics like bribery, corruption, fraud, pilferage, cartel formation, submission of fake/false/forged documents, certificates, information to BHEL or if they tamper with tendering procedure affecting the ordering process or fail to execute a contract, or rejection of 3 consecutive supplies or if their firms / works are under strike/lockout for a long period. Bidder may refer “Guidelines for Suspension of Business Dealings with Suppliers/ Contractors” available on www.bhel.com for more details.

The Bidder declares that they will not enter into any illegal or undisclosed agreement or understanding, whether formal or informal with other Bidder(s). This applies in particular to prices, specifications, certifications, subsidiary contracts, submission or non-submission of bids or any other actions to restrict competitiveness or to introduce cartelization in the bidding process. In case, the Bidder is found having indulged in above activities, suitable action shall be taken by BHEL as per extant policies / guidelines.

10. The bidder along with its associate/collaborators/sub-contractors/sub-vendors/consultants/service providers shall strictly adhere to BHEL Fraud Prevention Policy displayed on BHEL website <http://www.bhel.com> and shall immediately bring to the notice of BHEL Management about any fraud or suspected fraud as soon as it comes to your notice.
11. Offer is to be submitted in English language only.
12. For this procurement, the local content to categorize a supplier as a Class-I local supplier/ Class-II local supplier/ Non-local supplier and purchase preference to Class-I local supplier, is as defined in Public procurement (Preference to Make in India), Order 2017 dated 16.09.2020 issued by DPIIT.

In case of subsequent Orders issued by the Nodal Ministry, changing the definition of local content for the items of the NIT, the same shall be applicable even if issued after issue of this NIT, but before opening of price bids against this NIT. Default margin of purchase preference shall be 20% for Class-I local supplier only.

13. The Bidder shall mandatorily submit Declaration as mentioned under Rule 144(xi) of General Financial Rules, 2017 amendment dt 23.07.2020 issued by Ministry of Finance, Govt. of India. Where applicable, evidence of valid registration by the Competent Authority shall be attached.

The Competent Authority for the purpose of registration under this Order shall be the Registration Committee constituted by the Department for Promotion of Industry and Internal Trade (DPIIT). Refer Annexure-X for ‘Restrictions under Rule 144(Xi) of General Financial Rules,2017 amendment dt: 23.07.2020’.

B. GUIDELINES FOR PREPARATION OF OFFER:

1. Quotation shall be submitted in Single Part Bid, Two Part Bid or Three Part Bid, as called for in the tender:
 - **SINGLE PART BID:** Technical and Commercial Bid with prices along with price summary & filled in BHEL Standard Commercial terms and conditions in a single sealed envelope.
 - **TWO PART BID:** Unpriced offer i.e. “Techno-commercial Bid” with filled in BHEL Standard Commercial terms and conditions in a sealed envelope **along with the copy of the “Price Bid” without the prices** should be enclosed in one cover and the cover must be super scribed **“Techno-commercial offer)** and Priced offer i.e. “Price Bid” containing price summary in a separate sealed envelope and must be super scribed **“Price Bid”**.

Both these envelopes shall be enclosed in a single sealed envelope superscribed with enquiry number, due date of tender and any other details as called for in the tender document.

- **THREE PART BID:** Pre-qualification Bid (Part-I), Techno Commercial Bid with filled in BHEL Standard Commercial terms and conditions (Part-II), and Price Bid (Part-III). All three envelopes shall be enclosed in a single sealed envelope superscribed with enquiry number, due date of tender and any other details as called for in the tender document.

If any of the offers (Part I, Part II or Part III) are not submitted before the due date and time of submission (or) if any part of the offer is incomplete, the entire offer of the bidder is liable for rejection.

2. Supplier shall ensure to superscribe each envelope with RFQ number, RFQ Date, RFQ Due date and time, Item Description and Project clearly & boldly. Also mention on the envelope whether it is “Techno Commercial Bid” or “Price Bid” or “Pre-Qualification Bid”.

Please ensure complete address, department name and purchase executive name is mentioned on the envelope (before dropping in the tender box or handing over) so that the tender is available in time for bid opening.

3. BHEL standard Commercial Terms and Conditions (duly filled, signed & stamped) must accompany Technical-Commercial offer without fail and should be submitted in original only.

The above indicated submission of Offers in “sealed envelope/hard copy” as mentioned in points B.1-B.3 is applicable for tenders that are not floated through E-Procurement System (EPS).

4. Validity: Unless otherwise specified in SCC (special commercial conditions of contract), the offer will be valid for a period of 90 days from the date of part-I bid opening and in case of Negotiation/Counter-offer/Reverse Auction, price validity will apply afresh for a period of 60 days from the date of according final price by bidder (or) up to original validity period, whichever is later.
5. Any of the terms and conditions not acceptable to supplier, shall be explicitly mentioned in the Techno-Commercial Bid.

If no deviations are brought out in the offer it will be treated as if all terms and conditions of this enquiry are accepted by the supplier without deviation.

6. Deviation to this specification/item description, if any, shall be brought out clearly indicating “DEVIATION TO BHEL SPECIFICATION” without fail, as a part of Techno-Commercial Bid.

If no deviations are brought out in the offer it will be treated as if the entire specification of this enquiry is accepted without deviation.

7. Suppliers shall submit one set of original catalogue, datasheets, bill of materials, dimensional drawings, mounting details and/or any other relevant documents called in purchase specification as part of Technical Bid.
8. "Price Bid" shall be complete in all respects containing price break-up of all components along with all applicable taxes and duties, freight charges (if applicable) etc. Once submitted no modification / addition / deletion will be allowed in the "Price Bid." Bidders are advised to thoroughly check the unit price, total price to avoid any discrepancy.
9. In addition, bidder shall also quote for erection & commissioning charges/erection supervision & commissioning charges (E&C service charges), documentation charges, testing Charges (type & routine), training charges etc. if & as applicable along with corresponding tax. The price summary must indicate all the elements clearly.
10. Wherever applicable, bidders should indicate "lumpsum" Erection and Commissioning (or) Erection Supervision and Commissioning charges, as applicable (including To & Fro Fare, Boarding, Lodging, Local Conveyance etc.) for carrying out E&C activity and further handing over to customer.
The quotation shall clearly indicate scope of work, likely duration of commissioning, pre-commissioning checklist (if any).
11. Wherever bidders require PAC (Project Authority Certificate)/applicable certificates for import of raw materials, components required for DECC,EPCG Power Projects, Export Projects or other similar projects wherein supplies are eligible for customs duty benefits, lists and quantities of such items and their values (CIF) has to be mentioned in the offer. Prices must be quoted taking into account of such benefits.
12. Prices should be indicated in both figures & words. Bid should be free from correction/overwriting, using corrective fluid, etc. Any interlineation, cutting, erasure or overwriting shall be valid only if they are attested under full signature(s) of person(s) signing the bid else bid shall be liable for rejection.
Any typographical error, totalling mistakes, currency mistake, multiplication mistake, summing mistakes etc. observed in the price bids will be evaluated as per **Annexure III** "Guidelines for dealing with Discrepancy in Words & Figures – quoted in price bid" and BHEL decision will be final.
13. Documents submitted with the offer shall be signed and stamped in each page by authorized representative of the bidder. However, this requirement is not mandatory for offers uploaded through E-Procurement System (EPS).

C. GUIDELINES FOR OFFER SUBMISSION:

The under-mentioned clauses 1, 2&3 will not be applicable for EPS tenders.

1. Offers / Quotations must be dropped in tender box before 13.00 Hrs. on or before due date mentioned in RFQ. The offers are to be dropped in the proper slot of the Tender Box kept in our reception area with caption "CE, SC&PV, DEFENCE".

Tenders are opened on 3 days in a week (Monday/Wednesday/Friday). Tender must be deposited in the slot corresponding to the day (Monday - Box no.4/Wednesday - Box no. 6 /Friday - Box no.8) while depositing the offer.

2. E-Mail/ Internet/EDI offers received in time shall be considered only when such offers are complete in all respects. In case of offers received through E-mail, please send the offer to the email ID specified in the SCC document of the tender.
3. Offers of Vendors who already have a valid Technical/Commercial MOU with BHEL-EDN for the items of the RFQ shall mention the relevant MOU reference no. and give only such other details not covered in the MOU.

4. In cases where tender documents are bulky, or due to some reasons tender documents are required to be submitted by hand or through posts/couriers, the offers are to be handed over either of the two purchase officers whose names are mentioned in the SCC document of tender RFQ.
5. Tenders will be opened on due date, time and venue as indicated in the RFQ in the presence of bidders at the venue indicated in the RFQ. For EPS tenders, e-mail notifications will be automatically generated and forwarded to registered e-mail ID/s of bidders during opening of tenders.
6. Bidder will be solely responsible:
 - a. For submission of offers before due date and time. Offers submitted after due date and time will be treated as "Late offers" and will be rejected.
 - b. For submission of offers in the correct compartment of the tender box based on the day of due date (Monday/Wednesday/Friday). Please check before dropping your offer in the correct tender box.
 - c. For depositing offers in proper sealed condition in the tender box. If the bidder drops the tender in the wrong tender box (or) if the tender document is handed over to the wrong person, BHEL will not be responsible for any such delays.
 - d. For offers received through email etc., suppliers are fully responsible for lack of secrecy on information and ensuring timely receipt of such offers in the tender box before due date & time (This clause will not be applicable for EPS tenders).

The above indicated submission of Offers as mentioned in points 6.a-6.d is applicable for tenders that are not floated through EPS.

- e. In case of e-tender, all required documents should be uploaded before due date and time. Availability of power, internet connections, system/software requirements etc. will be the sole responsibility of the bidder.

Wherever assistance is needed for submission of e-tenders, help-line numbers as available in the website of service provider of BHEL may be contacted.

Purchase Executive/ BHEL shall not be responsible for any of the activities relating to submission of offer.

D. PROCESSING OF OFFERS RECEIVED:

1. Any discount/ revised offer submitted by the supplier on its own shall be accepted provided it is received on or before the due date and time of offer submission (i.e. Part-I bid).
The discount shall be applied on pro-rata basis to all items unless specified otherwise by the bidder.
2. Changes in offers or Revised offers given after Part-I bid opening shall not be considered as a part of the original offer unless such changes/revisions are requested by BHEL.
In case of withdrawal of any Technical/Commercial deviation(s) by the bidder before opening of price bids/conducting the Reverse Auction, revision of price/impact bid will not be accepted.
3. In case there is no change in the technical scope and/ or specifications and/ or commercial terms & conditions, the supplier will not be allowed to change any of their bids after Technical bids are opened (after the due date and time of tender opening).

4. In case of changes in scope and/ or technical specifications and/ or commercial terms & conditions by BHEL and it accounts for price implications from bidders, all techno-commercially acceptable bidders shall be asked by BHEL (after freezing the scope, technical specifications and commercial terms & conditions) to submit the impact of such changes on their price bid.

Impact price will be applicable only for changes in technical specification / commercial conditions by BHEL. The impact price must be submitted on or before the cut-off date specified by BHEL and the original price bid and the price impact bid will be opened together at the time of price bid opening.

5. Un-opened bids (including price bids) will be returned to the respective bidders after release of Purchase order.

Regarding Offers for EPS tenders that get rejected on PQC/ techno-commercial grounds, the bids for the subsequent parts will not be opened i.e., both technical bid and price bid (Parts-II & III) will not be opened in case of rejection on PQC ground and price bid (Part-II/Part-III, as applicable) will not be opened in case of rejection on techno-commercial ground.

6. After receipt of Purchase Order, supplier should submit required documents viz., specified drawings, bill of materials, datasheets, catalogues, quality plan, test procedure, type test report , O & M Manuals and/or any other relevant documents as per Specification/Purchase Order, as and when required by BHEL/ Customer.
7. Any deviation to the terms and conditions not mentioned in the quotation by supplier in response to this enquiry will not be considered, if put forth subsequently or after issue of Purchase Order, unless clarification is sought for by BHEL and agreed upon in the Purchase Order.
8. Evaluation shall be on the basis of delivered cost (i.e. "Total Cost to BHEL").

"Total Cost to BHEL" shall include total basic cost, packing & forwarding charges, taxes and/or duties (as applicable), freight charges, taxes on Services, customs clearance charges for imported items, any other cost indicated by bidder for execution of the contract and loading factors (for non-compliance to BHEL Standard Commercial Terms & Conditions).

Benefits arising out of Nil Import Duty on DEEC, EPCG, DFIA Projects, Physical Exports or such 100% exemptions (statutory benefits), project imports, customer reimbursements of statutory duties (like Basic Customs Duty and cess on customs duty), Input tax credits as applicable will also be taken into account for arriving at the Total cost to BHEL (wherever applicable and as indicated in SCC document of tender).

For EPS tenders, it shall be noted that the prices (including discounts) vis-a-vis currency quoted in EPS portal only will be considered as Final for the purpose of evaluation of the lowest bidder.

Bidder shall ensure to indicate the applicable taxes against each line item in online portal, failing to which the same will be considered as inclusive/NIL.

In the course of evaluation, if more than one bidder happens to occupy L-1 status, effective L-1 will be decided by soliciting discounts from the respective L-1 bidders.

In case more than one bidder happens to occupy the L-1 status even after soliciting discounts, the L-1 bidder shall be decided by a toss/draw of lots, in the presence of the respective L-1 bidder(s) or their representative(s).

Ranking will be done accordingly. BHEL's decision in such situations shall be final and binding.

9. The evaluation currency for this tender shall be INR. For evaluation of offers in foreign currency, the exchange rate (TT selling rate of SBI) shall be taken as under:

Single part bids: Date of tender opening

Two/three part bids: Date of Part-I bid opening

Reverse Auction: Date of Part-I bid opening

In case of Performance Bank Guarantee (PBG) also, exchange rate will be considered as mentioned above for converting foreign currency to Indian currency and vice versa.

If the relevant day happens to be a bank holiday, then the exchange rate as on the previous working day of the bank (SBI) shall be taken.

10. Ranking (L-1, L-2 etc.) shall be done only for the techno-commercially acceptable offers.
11. GeM Seller ID shall be mandatory before placement of order/award of contract for goods and services to the successful bidder(s), for orders exceeding Rs.25 lakhs (including all taxes etc.).

Department of Expenditure (DoE) OM no.6/9/2020-PPD dated: 24.08.2020 may be referred in this regard.

E. INFORMATION ON PAYMENT TERMS:

1. All payments will be through Electronic Fund transfer (EFT). Vendor has to furnish necessary details as per BHEL standard format (**Refer Annexure IV**) for receiving all payments through NEFT.(Applicable for Indian vendors only).
2. In case of High Sea Sales transaction, customs clearance of the consignment landed on Indian Sea/Air ports will be done by BHEL based on the original HSS documents provided by vendors.
All warehousing charges due to delay in submission of complete and or correct HSS documents to BHEL will be to supplier's account only. Such recovery will be made out of any of the available bills (**Refer Annexure V**).
3. Statutory deductions, if any, will be made and the deduction certificate shall be issued.
 - A. In case vendor does not provide PAN details, the TDS deduction shall be at the maximum percentage stipulated as per the provisions of Income Tax Act.
In addition to the above, Foreign vendors shall also submit relevant details of their bankers like Swift Code, Banker's Name &Address etc.
 - B. TDS deduction as per section 51 of CGST Act,2017 shall be applicable as per Gazette Notification No. 50/2018-Central Tax, Dated: 13th September 2018. TDS deduction is also applicable on purchase of goods as per the latest notification under section 194Q, and subsequent notification(s) as and when released by Govt. authorities.
4. Procurement of Goods/ Works/ Services/ Consultancy Services [under clause relating to "Income Tax and Corporate Tax" or "TDS" of Model ITBs]
 - a) Provision w.r.t. TDS on Purchase of Goods under section 194Q of Income Tax Act applicable from 01.07.2021 is as under:
 - i. TDS as applicable will be deducted by BHEL under section 194Q of the Income Tax Act, 1961 on Purchases exceeds, the amount of Rupees. 50 Lakhs or limit defined therein from time to time during the financial year under the Indian Income Tax act 1961.
 - ii. Since BHEL is liable to deduct Income Tax TDS under section 194Q, the provision of TCS as per section 206C(1H) of the Income Tax Act, 1961 shall not be applicable.

- b) Higher rate of TDS for non-filers of ITR as per Section 206AB of Income Tax Act, 1961, in case of any vendor who does not filed their Income Tax Return for both of the two previous years preceding to current year and aggregate amount of TDS is more than or equal to Rs. 50,000/- in each of those previous two years (or limit defined by Govt. from time to time), then TDS will be deducted at the higher of following rates:
- (i) Twice the rate mentioned in relevant TDS section.
 - (ii) Twice the rate or rates in force
 - (iii) 5%

5. Incomplete documentation will not be accepted. Delayed submission of invoice / documents may result in corresponding delay in payment. In this connection, request to also refer clause: G about invoicing & payment formalities under GST regime.

Applicable documents shall be submitted to the purchaser at the time of execution of supplies/services for availing GST input credits.

F. STANDARD PAYMENT TERMS OF BHEL-EDN:

<u>PURCHASE ORDERS FOR:</u>	<u>SUPPLY WITH SERVICE(S)</u>	<u>SUPPLY ONLY</u>
<u>INDIGENOUS PROCUREMENT</u>	<p>a. 100% of basic value with taxes and freight will be paid in 45 days from the date of dispatch or 15 days from the date of submission of complete set of documentation, whichever is later.</p> <p><u>Note:</u> In case PBG is not furnished, only 90% payment will be released against 100% claim without the consent of Vendor. This 10% basic amount withheld towards PBG will be paid either against submission of supplementary invoice & Original PBG (or) against supplementary invoice without PBG after expiry of Warranty period.</p>	<p>b. 100% of PO value with taxes and freight will be paid in 45 days from the date of dispatch or 15 days from the date of submission of complete set of documentation, whichever is later.</p>
<u>IMPORT PROCUREMENT</u>	<p>c. 100% of basic value will be paid against usance draft of 45 days from the date of AWB/BOL on submission of complete set of documents.</p> <p><u>Note:</u> In case PBG is not furnished, only 90% payment will be released against 100% claim without the consent of Vendor. This 10% basic amount withheld towards PBG will be paid either against submission of supplementary invoice & Original PBG (or) against supplementary invoice without PBG after expiry of Warranty period.</p>	<p>d. 100% of PO value will be paid against usance draft of 45 days from the date of AWB/BOL on submission of complete set of documents.</p>

<p><u>HIGH-SEA SALES PROCUREMENT</u></p>	<p>e. 100% of basic value will be paid in 45 days from the date of signing of High Sea Sale agreement or 15 days from the date of submission of complete set of documentation, whichever is later</p> <p><u>Note:</u> In case PBG is not furnished, only 90% payment will be released against 100% claim without the consent of Vendor. This 10% basic amount withheld towards PBG will be paid either against submission of supplementary invoice & Original PBG (or) against supplementary invoice without PBG after expiry of Warranty period.</p>	<p>f. 100% of basic value will be paid in 45 days from the date of signing of High Sea Sale agreement or 15 days from the date of submission of complete set of documentation, whichever is later.</p>
---	---	--

g. Erection and Commissioning:

Evaluation methodology: Unless and otherwise specified in SCC, E&C charges should not be less than 10% of the main supply value. In case the quoted total E&C value is less than 10% of the main supply value, BHEL shall evaluate Bidders Price deducting differential amount from main supply price proportionally from all items and apportioning towards E&C charges.

Payment term: 100% E&C charges along with tax as applicable, will be paid in 15 days from the date of submission of supplementary invoice/documents against proof of completion of E&C.

h. Erection Supervision and Commissioning:

Evaluation methodology: Unless and otherwise specified in SCC, E&C charges should not be less than 5% of the main supply value. In case the quoted total E&C value is less than 5% of the main supply value, BHEL shall evaluate Bidders Price deducting differential amount from main supply price proportionally from all items and apportioning towards E&C charges.

Payment term: 100% E&C charges along with tax as applicable, will be paid in 15 days from the date of submission of supplementary invoice/documents against proof of completion of E&C.

i. Comprehensive Annual Maintenance Contract:

Evaluation methodology: Unless and otherwise specified in SCC, CAMC will be applicable for a period of 04 years from the date of expiry of warranty period (or) from the date of completion of commissioning of equipment, whichever is later and the total CAMC value should not be less than 20% of the main supply value. In case the quoted total CAMC value is less than 20% of the main supply value, BHEL shall evaluate Bidders Price deducting differential amount from main supply price proportionally from all items and apportioning towards CAMC charges.

Payment terms: 100% CAMC charges along with tax as applicable, will be paid in 15 days from the date of submission of supplementary invoice/documents against proof of completion of CAMC on yearly basis.

j. Terms of Payment for Training: 100% payment will be made in 45 days from the date of completion of Training or 15 days from the date of submission of complete set of invoice along with documentary evidence, whichever is later.

LOADING FACTORS FOR DEVIATION IN PAYMENT TERMS (APPLICABLE FOR IMPORT PROCUREMENT ONLY):

- 1) For offers received with Sight draft payment term in place of Usance draft, loading applicable will be 1.0% of basic value.
- 2) For offers received with Letter of Credit payment term with Usance of 45 days, loading applicable will be 2.5% of basic value.
Additional loading of 2% will be applicable for payment term as Letter of Credit at Sight.
- k. Any payment term with credit period of less than 45 days for indigenous supply/HSS and any other variation of payment terms are liable for rejection.
- l. Standard payment terms indicated in Clauses: F (a), (b), (c), (d), (e), (f), (g), (h), (i) & (j) will not attract any loading.

Note 1: Basic value of Purchase Order mentioned above will include all components of the purchase order and will exclude only taxes, duties, freight, training charges, E&C and AMC charges (wherever applicable). Wherever the Purchase Order is split into import portion and indigenous portion of supply, minimum % to be quoted for Services, wherever mentioned, will be of both purchase order values put together.

Note 2: In case of multiple packages/units in a power plant, payment of E&C charges will be processed on pro-rata basis.

Note 3: No deviation will be permitted from the duration of Guarantee/Warranty and/or Comprehensive Annual Maintenance Contract period specified in SCC.

G. Terms & Conditions to be complied under GST regime:

1. All invoices to contain BHEL-EDN (buyer) GSTIN number: 29AAACB4146P1ZB. However for CGST +SGST/UGST billing outside the state of Karnataka, invoice has to be generated with BHEL's Nodal Agency GSTIN number. Address of Nodal Agency along with GSTIN number will be provided by BHEL at the time of issuing dispatch clearance.
2. The Bidder shall mention Bidder's GSTIN number in all quotations and Invoices submitted.
3. The Bidder shall also mention HSN (Harmonized System of Nomenclature) / SAC (Services Accounting Code) mandatorily in all quotations and invoices submitted.
4. Invoice submitted should be in the format as specified under GST Laws viz., all details as mentioned in Invoice Rules like GST registration number(GSTIN), invoice number with date of issue, quantity, rate, value, taxes with nomenclature – CGST, SGST, UGST,IGST mentioned separately, HSN Code / SAC Code etc. Invoice should be submitted in original for buyer plus duplicate for credit availment.
5. Payment of GST to Vendor will be made only if it is matching with data uploaded by the Vendor in GST portal.
6. For invoices paid on Reverse charge basis – “Tax payable on reverse charge basis” to be mentioned on the invoice.
7. In case GST credit is delayed/denied to BHEL due to non/delayed receipt of goods and/or tax invoice or expiry of timeline prescribed in GST law for availing such ITC, or any other reasons not attributable to BHEL, GST amount will be recoverable from vendor along with interest levied/ leviable on BHEL.
8. In case vendor delays declaring such invoice in his return and GST credit availed by BHEL is denied or reversed subsequently as per GST law, GST amount paid by BHEL towards such ITC reversal as per GST law will be recoverable from vendor/contractor along with interest levied/ leviable on BHEL.

9. Vendor should intimate BHEL immediately on the same date of invoicing without any delay.
10. In case of discrepancy in the data uploaded by supplier in the GSTN portal or in case of any shortages or rejection in the supply, then BHEL will not be able to avail the tax credit and will notify the supplier of the same. Supplier has to rectify the data discrepancy in the GSTN portal or issue credit note (details to be uploaded in GSTN portal) for the shortages or rejections in the supplies, within the calendar month notified by BHEL.
11. Bidders to note that Rules & Regulations pertaining to E-way bill system are to be strictly adhered to, as and when notified by Govt. authorities.
12. As per Notification 88/2020-Central Tax dated 10th November 2020 (applicable w.e.f. 01 January 2021), the turnover for applicability of E-invoicing provisions has been reduced from 500 crores to 100 crores. In other words, registered person [other than a SEZ unit and those referred in Rule 54(2), 54(3), 54(4) and 54(4A) of the CGST Rules], whose aggregate turnover in any preceding financial year from 2017-18 onwards exceeds 100 crores, is required to comply with the requirement of IRN and QR code in respect of supply of goods or services or both to a registered person or for exports.

H. Performance bank guarantee (PBG):

Performance bank guarantee (PBG) will be applicable as called in the tender documents. Unless otherwise specified in the SCC, the PBG against performance of the contract shall be valid for a period of 24 months from the date of dispatch of goods + claim period of 03 months, for a value equal to 10 % of the basic value of the purchase order which will include all components of the purchase order and will exclude only taxes, duties, freight, training charges, E&C and AMC charges (wherever applicable).

1. The BG issued in Indian Rupees by Banks in India is to be executed on Non-Judicial Stamp paper/e-stamp paper of appropriate value as per Stamp Act prevailing in the State(s) where the BG is submitted or is to be acted upon or the rate prevailing in the State where the BG was executed, whichever is higher. The Stamp Paper/e-stamp paper shall be purchased in the name of Vendor/Bank issuing the guarantee.
2. No deviation for the duration and value of PBG will be permitted.
3. PBG shall be from any of the BHEL consortium of bankers (**refer Annexure VI**).
4. PBGs from nationalized banks are also acceptable.
5. PBG should be sent directly by the bank to the dealing executive mentioned in the purchase order located at the address mentioned in the purchase order.
6. PBG should be in the format specified (**refer Annexure VII**). No deviation to this format will be allowed. However in case BHEL changes the PBG format, bidder shall honor the same.
7. Bank Guarantee should be enforceable in Bangalore.
8. In Case of Bank Guarantees submitted by Foreign Vendors-
 - a. From Nationalized/Public Sector / Private Sector/ Foreign Banks (BG issued by Branches in India) can be accepted subject to the condition that the Bank Guarantee should be enforceable in Bangalore.
 - b. From Foreign Banks (wherein Foreign Vendors intend to provide BG from local branch of the Vendor country's Bank)
 - b.1 Please note that Bank Guarantee issued by any of the Consortium Banks only will be accepted by BHEL. As such, Foreign Vendor needs to make necessary arrangements for issuance of Counter-Guarantee by Foreign Bank in favour of the Indian Bank's (BHEL's Consortium Bank) branch in India.

It shall be noted that all charges for issuance of Bank Guarantee/ counter- Guarantee should be borne by the Foreign Vendor.

b.2 In case, Foreign Vendors intend to provide BG from Overseas Branch of our Consortium Bank (e.g. if a BG is to be issued by SBI Frankfurt), the same is acceptable. However, the procedure at sl.no. b.1 is required to be followed.

b.3 The BG issued may preferably be subject to Uniform Rules for Demand Guarantees (URDG) 758 (as amended from time to time).

9. Expired PBGs will be returned only after expiry of the claim period.

10. PBG shall not be applicable for spares.

I. PURCHASE PREFERENCE FOR MSE(MICRO AND SMALL ENTERPRISES) VENDORS:

Purchase preference will be given to MSEs as defined in Public Procurement Policy for Micro and Small Enterprises (MSEs) Order, 2012 dated 23.03.2012 issued by Ministry of Micro, Small and Medium Enterprises and its subsequent Orders/Notifications issued by concerned Ministry. If the bidder wants to avail the Purchase preference, the bidder must be the manufacturer of the offered product in case of bid for supply of goods. Traders are excluded from the purview of Public Procurement Policy for Micro and Small Enterprises. Relevant documentary evidence in this regard shall be uploaded along with the bid in respect of the offered product. Purchase preference to Micro and Small Enterprises clause in the bid, the same will get precedence over this clause.

1. If tendered quantity is Splitable: In tender, participating MSEs quoting price within price band of L1+15 percent shall also be allowed to supply a portion of requirement by bringing down their price to L1 price in a situation where L1 price from someone other than a MSE and such MSE shall be allowed to supply at least 25% of total tendered value. In case of more than one such MSE, the supply shall be shared proportionately (to tendered quantity).

- 3% of the 25% will be earmarked for women owned MSEs.
- 25% of the 25% (i.e., 6.25% of the total enquired quantity) will be earmarked for SC/ST owned MSE firms provided conditions as mentioned in (1) & (2) are fulfilled.
- In case where no SC/ST category firms are meeting the conditions mentioned in (1) and (2) or have not participated in the tender, the 6.25% of earmarked quantity for SC/ST owned MSE firms will be distributed among the other eligible MSE vendors who have participated in the tender.

2. If tendered quantity is Non-Splitable: If L-1 is not an MSE and MSE Seller (s) has/have quoted price within L-1+ 15% of margin of purchase preference /price band defined in relevant policy, such Seller shall be given opportunity to match L-1 price and contract will be awarded for 100% of total value.

J. INTEGRITY COMMITMENT IN THE TENDER PROCESS, AND EXECUTION OF CONTRACTS:

1. Commitment by BHEL: BHEL commits to take all measures necessary to prevent corruption in connection with the Tender process and execution of the Contract. BHEL will, during the tender process, treat all bidder / suppliers in a transparent and fair manner, and with equity.
2. Commitment by Bidder(s)/ Contractor(s):
 - a. The Bidder(s)/ Contractor(s) commit(s) to take all measures to prevent corruption and will not directly or indirectly try to influence any decision or benefit which he is not legally entitled to.
 - b. The Bidder(s)/ Contractor(s) will not enter with other Bidder(s) into any undisclosed agreement or understanding or any actions to restrict competition.
 - c. The Bidder(s)/ Contractor(s) will not commit any offence under the relevant Acts. The Bidder(s)/ Contractor(s) will not use improperly, for purposes of competition or personal gain or pass on to others, any information or document provided by BHEL as part of business relationship.

- d. The Bidder(s)/ Contractor(s) will, when presenting his bid, disclose any and all payments he has made, and is committed to or intends to make to agents, brokers or any other intermediaries in connection with the award of the contract and shall adhere to the relevant guidelines issued from time to time by Government of India/ BHEL.

If the Bidder(s) / Contractor(s), before award or during execution of the Contract commit(s) a transgression of the above or in any other manner such as to put his reliability or credibility in question, BHEL is entitled to disqualify the Bidder(s) / Contractor (s) from the tender process or terminate the contract and/ or take suitable action as deemed fit.

K) Integrity Pact (IP):

(a) IP is a tool to ensure that activities and transactions between the Company and its Bidders/ Contractors are handled in a fair, transparent and corruption free manner. Following Independent External Monitors (IEMs) on the present panel have been appointed by BHEL with the approval of CVC to oversee implementation of IP in BHEL.

Sl	IEM	Email
1.	Shri Otem Dai, IAS (Retd.)	iem1@bhel.in
2.	Shri Bishwamitra Pandey, IRAS (Retd.)	iem2@bhel.in
3.	Shri Mukesh Mittal, IRS (Retd.)	iem3@bhel.in

(b) The IP as enclosed with the tender is to be submitted (duly signed by authorized signatory) along with techno-commercial bid (Part-I, in case of two/ three part bid). Only those bidders who have entered into such an IP with BHEL would be competent to participate in the bidding. In other words, entering into this Pact would be a preliminary qualification.

(c) Please refer Section-8 of IP for Role and Responsibilities of IEMs. In case of any complaint arising out of the tendering process, the matter may be referred to any of the above IEM(s). All correspondence with the IEMs shall be done through email only.

Note: No routine correspondence shall be addressed to the IEM (phone/ post/ email) regarding the clarifications, time extensions or any other administrative queries, etc. on the tender issued. All such clarification/ issues shall be addressed directly to the tender issuing (procurement) department's officials whose contact details are indicated in SCC document of tender.

Annexure

Annexure I
Guidelines for Indian Agents

- **Definition of Indian Agent:** An Indian Agent of foreign principal is an individual, a partnership, an association of persons, a private or public company, that carries out specific obligation(s) towards processing of BHEL tender or finalization or execution of BHEL's contract on behalf of the foreign supplier.

In case of yes, vendor to note the following and reply accordingly:

- BHEL shall deal directly with foreign vendors, wherever required, for procurement of goods. However, if the foreign principal desires to avail of the services of an Indian agent, then the foreign principal should ensure compliance to regulatory guidelines - which require mandatory submission of an Agency Agreement.
- It shall be incumbent on the Indian agent and the foreign principal to adhere to the relevant guidelines of Government of India, issued from time to time.
- The Agency Agreement should specify the precise relationship between the foreign OEM / foreign principal and their Indian agent and their mutual interest in the business. All services to be rendered by agent/ associate, whether of general nature or in relation to the particular contract, must be clearly stated by the foreign supplier/ Indian agent. Any payment, which the agent or associate receives in India or abroad from the OEM, whether as commission or as a general retainer fee should be brought on record in the Agreement and be made explicit in order to ensure compliance to laws of the country.
- Any agency commission to be paid by BHEL to the Indian agent shall be in Indian currency only.
- Tax deduction at source is applicable to the agency commission paid to the Indian agent as per the prevailing rules.
- In the absence of any agency agreement, BHEL shall not deal with any Indian agent (authorized representatives / associate / consultant, or by whatever name called) and shall deal directly with the foreign principal only for all correspondence and business purposes.
- The "Guidelines for Indian Agents of Foreign Suppliers" enclosed at annexure - 'A' shall apply in all such cases.

- viii. The supply and execution of the Purchase Order (including indigenous supplies/ service) shall be in the scope of the OEM/ foreign principal. The OEM/ foreign principal should submit their offer inclusive of all indigenous supplies/ services and evaluation will be based on 'total cost to BHEL'. In case OEM/ foreign principal recommends placement of order(s) towards indigenous portion of supplies/ services on Indian supplier(s)/ agent on their behalf, the credentials/ capacity/ capability of the Indian supplier(s)/ agent to make the supplies/ services shall be checked by BHEL as per the extant guidelines of Supplier Evaluation, Approval & Review Procedure (SEARP), before opening of price bids. In this regard, details may be checked as per Annexure-B (copy enclosed). It will be the responsibility of the OEM/ foreign principal to get acquainted with the evaluation requirements of Indian supplier/ agent as per SEARP available on www.bhel.com.

The responsibility for successful execution of the contract (including indigenous supplies/ services) lies with the OEM/ foreign principal. All bank guarantees to this effect shall be in the scope of the OEM/ foreign principal.

--x--

Vendor's Signature with Seal

Guidelines for Indian Agents of Foreign Suppliers

- 1.0 There shall be compulsory registration of agents for all Global (Open) Tender and Limited Tender. An agent who is not registered with BHEL shall apply for registration in the registration form in line with SEARP.
- 1.1 Registered agents will file an authenticated Photostat copy duly attested by a Notary Public/Original certificate of the Principal confirming the agency agreement and giving the status being enjoyed by the agent and the commission/ remuneration/ salary/ retainership being paid by the principal to the agent before the placement of order by BHEL.
- 1.2 Wherever the Indian representatives have communicated on behalf of their principals and the foreign parties have stated that they are not paying any commission to the Indian agents, and the Indian representative is working on the basis of salary or as retainer, a written declaration to this effect should be submitted by the party (i.e. Principal) before finalizing the order.
- 2.0 **Disclosure of particulars of agents/ representatives in India, if any.**
- 2.1 Tenderers of Foreign nationality shall furnish the following details in their offers:
 - 2.1.1 The Bidder(s)/ Contractor(s) of foreign origin shall disclose the name and address of the agents/ representatives in India if any and the extent of authorization and authority given to commit the Principals. In case the agent/ representative be a foreign Company, it shall be confirmed whether it is existing Company and details of the same shall be furnished.
 - 2.1.2 The amount of commission/ remuneration included in the quoted price(s) for such agents/ representatives in India.
 - 2.1.3 Confirmation of the Tenderer that the commission/ remuneration, if any, payable to his agents/ representatives in India, may be paid by BHEL in Indian Rupees only.
- 2.2 Tenderers of Indian Nationality shall furnish the following details in their offers:
 - 2.2.1 The Bidder(s)/ Contractor(s) of Indian Nationality shall furnish the name and address of the foreign principals, if any, indicating their nationality as well as their status, i.e. whether manufacturer or agents of manufacturer holding the Letter of Authority of the Principal specifically authorizing the agent to make an offer in India in response to tender either directly or through the agents/ representatives.
 - 2.2.2 The amount of commission/ remuneration included in the price (s) quoted by the Tenderer for himself.
 - 2.2.3 Confirmation of the foreign principals of the Tenderer that the commission/ remuneration, if any, reserved for the Tenderer in the quoted price(s), may be paid by BHEL in India in equivalent Indian Rupees on satisfactory completion of the Project or supplies of Stores and Spares in case of operation items.
- 2.3 In either case, in the event of contract materializing, the terms of payment will provide for payment of the commission/ remuneration, if any payable to the agents/ representatives in India in Indian Rupees on expiry of 90 days after the discharge of the obligations under the contract.
- 2.4 Failure to furnish correct and detailed information as called for in paragraph 2.0 above will render the concerned tender liable to rejection or in the event of a contract materializing, the same liable to termination by BHEL. Besides this there would be a penalty of banning business dealings with BHEL or damage or payment of a named sum.

ANNEXURE - II
LIST OF INTERNATIONAL GATEWAY AIRPORTS

For air based consignment, terms of delivery will be on FCA basis from following listed airports only. Vendors are requested to verify this list for use before submission of offer.

SCHEDULE NO	COUNTRY	CURRENCY CODE	AIRPORT
D01	UK	GBP	LONDON (HEATHROW)
D02	UK	GBP	NEW CASTLE
D03	UK	GBP	OXFORD. CHETLAM
D04	UK	GBP	BRISTOL. WELLINGBOROUGH
D05	UK	GBP	BIRMINGHAM
D06	UK	GBP	EAST MIDLANDS
D07	UK	GBP	MANCHESTER
D08	UK	GBP	LEEDS
D09	UK	GBP	GLASGOW
D10	FRANCE	EURO	PARIS (ROISSY) & LYON
D11	SWEDEN	EURO	STOCKHOLM
D12	SWEDEN	EURO	GOTHENBERG & MALMO
D13	ITALY	EURO	ROMA, MILAN
D14	ITALY	EURO	TURIN, BOLOGNA, FLORENCE
D15	NETHERLANDS	EURO	AMSTERDAM, ROTTERDAM
D16	AUSTRIA	EURO	VIENNA, LINZ, GRAZ
D17	BELGIUM	EURO	ANTWERP, BRUSSELS
D18	DENMARK	DKK	COPENHAGEN
D19	JAPAN	JPY	TOKYO, OSAKA
D20	SINGAPORE	SGD	SINGAPORE
D21	CANADA	CAD	TORONTO
D22	CANADA	CAD	MONTREAL
D23	USA	USD	NEW YORK, BOSTON
D24	USA	USD	CHICAGO
D25	USA	USD	SAN FRANCISCO, LOS ANGELES
D26	USA	USD	ALANTA, HOUSTON
D27	GERMANY	EURO	MUNICH, KOLN, DUSSELDORF, HANNOVER, HAMBURG, STUTTGART, DAMSTADT, MANIHIEM, NURUMBERG
D28	GERMANY	EURO	FRANKFURT
D29	GERMANY	EURO	BERLIN
D30	SWITZERLAND	SFR	BASLE, ZURICH, GENEVA
D31	SPAIN	EURO	BARCELONA
D32	AUSTRALIA	AUD	SYDNEY
D33	AUSTRALIA	AUD	MELBOURNE
D34	AUSTRALIA	AUD	PERTH
D35	CZECH	EURO	PRAGUE
D36	HONG KONG	HKD	HONG KONG
D37	NEW ZELAND	NZD	AUCKLAND
D38	RUSSIA	USD	MOSCOW
D39	SOUTH KOREA	USD	KIMPO INTERNATIONAL, INCHEON
D40	FINLAND	EURO	HELSINKI
D41	ROMANIA	EURO	BUCHAREST
D42	NORWAY	EURO	OSLO
D43	IRELAND	EURO	DUBLIN
D44	ISRAEL	USD	TEL AVIV
D45	UAE	USD	DUBAI
D46	OMAN	USD	MUSCAT
D47	EGYPT	USD	CAIRO
D48	TAIWAN	USD	TAIPEI
D49	UKRAINE	USD	KIEV
D50	CHINA	USD	SHANGHAI, SHENZHEN
D51	PHILIPINES	USD	MANILA
D52	MALAYSIA	USD	KUALALUMPUR, PE NANG
D53	CYPRUS	USD	LARNACA
D54	SOUTH AFRICA	USD	JOHANNESBERG, DURBAN
D55	SLOVAKIA	EURO	BARTISLOVA
D56	SAUDI ARABIA	SAR	RIYADH
D57	TURKEY	EURO	ISTANBUL
D58	THAILAND	USD	BANGKOK
D59	BRAZIL	USD	SAO PAULO, RIO DE JANEIRO

ANNEXURE – III

DISCREPANCY IN WORDS & FIGURES – QUOTED IN PRICE BID

Following guidelines will be followed in case of discrepancy in words & figures-quoted in price bid:

(a) If, in the price structure quoted for the required goods/services/works, there is discrepancy between the unit price and the total price (which is obtained by multiplying the unit price by the quantity), the unit price shall prevail and the total price corrected accordingly, unless in the opinion of the purchaser there is an obvious misplacement of the decimal point in the unit price, in which case the total price as quoted shall govern and the unit price corrected accordingly.

(b) If there is an error in a total corresponding to the addition or subtraction of subtotals, the subtotals shall prevail and the total shall be corrected; and

(c) If there is a discrepancy between words and figures, the amount in words shall prevail, unless the amount expressed in words is related to an arithmetic error, in which case the amount in figures shall prevail subject to (a) and (b) above.

(d) If there is such discrepancy in an offer, the same shall be conveyed to the bidder with target date upto which the bidder has to send his acceptance on the above lines and if the bidder does not agree to the decision of the purchaser, the bid is liable to be ignored.

ANNEXURE - IV
Electronic Funds Transfer (EFT) OR
Paylink Direct Credit Form

Please Fill up the form in **CAPITAL LETTERS** only.

TYPE OF REQUEST(Tick one): _____ CREATE _____ CHANGE

BHEL Vendor / Supplier Code:

Company Name :

Permanent Account Number(PAN):

Address

City: PINCODE STATE

Contact Person(s)

Telephone No:

Fax No:

e-mail id:

1 Bank Name:

2 Bank Address:

3 Bank Telephone No:

4 Bank Account No:

5 Account Type: Savings/Cash Credit

6 9 Digit Code Number of Bank and branch appearing on MICR cheque issued by Bank

7 Bank IFSC Code(applicable for NEFT)

8 Bank IFSC code(applicable for RTGS) (Indian Financial System Code)

- A I hereby certify that the particulars given above are true, correct and complete and that I, as a representative for the above named Company, hereby authorise BHEL, EDN, Bangalore to electronically deposit payments to the designated bank account.
- B If the transaction is delayed or not effected at all for reasons of incomplete or incorrect information, I would not hold BHEL / transferring Bank responsible.
- C This authority remains in full force until BHEL, EDN, Bangalore receives written notification requesting a change or cancellation.
- D I have read the contents of the covering letter and agree to discharge the responsibility expected of me as a participant under ECS / EFT.

Date:

Authorised Signatory:

Designation: _____ Telephone No. with STD Code _____

Company Seal

Bank Certificate

We certify that _____ has an Account No _____ with us and we confirm that the bank details given above are correct as per our records.

Date: _____ (.....)

Place: _____ Signature _____

Please return completed form along with a blank cancelled cheque or photocopy thereof to:

Bharath Heavy Electricals Ltd,

Attn:

Electronics Division, Mysore Road,

BANGALORE - 560 026

In case of any Query, please call concerned purchase executive.

ANNEXURE - V
PRESENT PROCEDURE FOR SALE IN TRANSIT (HIGH SEA SALES)

In case of High Sea Sales, vendor should submit following documents:

1. ORIGINAL HIGH SEA SALES AGREEMENT

- Sale agreement (on Rs. 200/- non-judicial stamp paper & notarised with 2 witnesses with identity) has to be signed between BHEL and the Party importing material. The date of the sale documents should be in between the date of House Air Way Bill / Bill of Lading and before landing of the goods in Indian origin.
- Following shall be included in the High Sea Sales Agreement:
"THE BUYER ALSO UNDERTAKE DISCHARGES, THE OBLIGATION AND FULFILLMENT OF CONDITIONS, IF ANY, ATTACHED TO THE IMPORTATION, ASSESSMENT AND CLEARANCE OF THE GOODS IN TERMS CUSTOMS TARIFF ACT 1975, THE CUSTOMS ACT 1962 & RULES & REGULATIONS MADE THERE UNDER AND OTHER RELEVANT ACTS, ORDERS, NOTIFICATIONS".

2. ORIGINAL INVOICES: INDIGENOUS RUPEE INVOICE & FOREIGN CURRENCY INVOICE

- Prices should be C.I.F., designated airport/seaport basis.
- I.E.C., C.S.T., K.S.T. Nos. to be mentioned.
- Description of item (Nomenclature), Unit & Quantity in both the Foreign Currency & the Indigenous Invoice in Rupee shall be exactly as per Purchase Order Description of item, Quantity and Unit. The Indigenous Invoice value shall be exactly as per Purchase Order value.
- Seller should give Foreign Currency Invoice from the original consignor. The Foreign Currency Invoice value should be at least 2% (two per cent) less than the Indigenous Rupee Invoice value in equivalent foreign currency.

4. ORIGINAL HOUSE AIR WAY BILL/ BILL OF LADING

- The sale agents should duly endorse House Air Way Bill (HAWB) for air shipments or original Bill of Lading (O.B.L.) for sea shipments and Foreign Currency Invoice in favour of BHEL-EDN.

5. ORIGINAL CARGO ARRIVAL NOTICE FROM FORWARDER.

6. ORIGINAL DELIVERY ORDER ISSUED IN NAME OF BHEL-EDN.

7. ORIGINAL PACKING LIST.

8. A LETTER TO THE COMMISSIONER OF CUSTOMS FOR EFFECTING ABOVE SALE.

9. A LETTER TO THE DEPUTY ASSESSOR (OCTROI) FOR EFFECTING ABOVE SALE IN FAVOUR OF BHEL.

REMARKS: In case vendor needs any clarifications on the above, the same may be sought in writing.



ELECTRONICS DIVISION, BANGALORE

Annexure-VI

BHEL MEMBER BANKS (LIST OF CONSORTIUM BANKS)

Bank Guarantee (BG) shall be issued from the following banks only:

Sl. No.	Nationalised Banks	Sl. No.	Public Sector Banks
1	Allahabad Bank	18	IDBI
2	Andhra Bank		
3	Bank of Baroda	Sl. No.	Foreign Banks
4	Canara Bank	19	CITI Bank N.A
5	Corporation Bank	20	Deutsche Bank AG
6	Central Bank	21	The Hongkong and Shanghai Banking Corporation Ltd. (HSBC)
7	Indian Bank	22	Standard Chartered Bank
8	Indian Overseas Bank	23	J P Morgan
9	Oriental Bank of Commerce		
10	Punjab National Bank	Sl. No.	Private Banks
11	Punjab & Sindh Bank	24	Axis Bank
12	State Bank of India	25	The Federal Bank Limited
13	Syndicate Bank	26	HDFC Bank
14	UCO Bank	27	Kotak Mahindra Bank Ltd
15	Union Bank of India	28	ICICI Bank
16	United Bank of India	29	IndusInd Bank
17	Vijaya Bank	30	Yes Bank

Note:

- All BGs must be issued from BHEL consortium banks listed above.
- This list is subject to changes. Hence vendors are requested to check this list every time before issuing BGs.
- Bank Guarantees issued by Co-operative Banks/Financial Institutions cannot be accepted under any circumstance.

Annexure-VII

BANK GUARANTEE FOR PERFORMANCE SECURITY

Bank Guarantee No:

Date:

To

NAME

& ADDRESSES OF THE BENEFICIARY

Dear Sirs,

In consideration of Bharat Heavy Electricals Limited (hereinafter referred to as the 'Employer' which expression shall unless repugnant to the context or meaning thereof, include its successors and permitted assigns) incorporated under the Companies Act, 1956 and having its registered office at _____¹ through its Unit at.....(name of the Unit) having awarded to (Name of the Vendor / Contractor / Supplier) with its registered office at _____² hereinafter referred to as the 'Vendor / Contractor / Supplier', which expression shall unless repugnant to the context or meaning thereof, include its successors and permitted assigns), a contract Ref No.....dated³ valued at Rs.....⁴ (Rupees -----)/FC.....(in words.....) for⁵ (hereinafter called the 'Contract') and the Vendor / Contractor / Supplier having agreed to provide a Contract Performance Bank Guarantee, equivalent to% (.... Percent) of the said value of the Contract to the Employer for the faithful performance of the Contract,

we,, (hereinafter referred to as the Bank), having registered/Head office at and inter alia a branch at being the Guarantor under this Guarantee, hereby, irrevocably and unconditionally undertake to forthwith and immediately pay to the Employer any sum or sums upto a maximum amount of Rs --⁶ (Rupees -----) without any demur, immediately on first demand from the Employer and without any reservation, protest, and recourse and without the Employer needing to prove or demonstrate reasons for its such demand.

Any such demand made on the Bank shall be conclusive as regards the amount due and payable by the Bank under this guarantee. However, our liability under this guarantee shall be restricted to an amount not exceeding Rs. _____.

We undertake to pay to the Employer any money so demanded notwithstanding any dispute or disputes raised by the Vendor / Contractor / Supplier in any suit or proceeding pending before any Court or Tribunal, Arbitrator or any other authority, our liability under this present being absolute and unequivocal.

The payment so made by us under this Guarantee shall be a valid discharge of our liability for payment thereunder and the Vendor / Contractor / Supplier shall have no claim against us for making such payment.

We thebank further agree that the guarantee herein contained shall remain in full force and effect during the period that would be taken for the performance of the said Contract/satisfactory completion of the performance guarantee period as per the terms of the Contract and that it shall continue to be enforceable till

all the dues of the Employer under or by virtue of the said Contract have been fully paid and its claims satisfied or discharged.

WeBANK further agree with the Employer that the Employer shall have the fullest liberty without our consent and without affecting in any manner our obligations hereunder to vary any of the terms and conditions of the said Contract or to extend time of performance by the said Vendor / Contractor / Supplier from time to time or to postpone for any time or from time to time any of the powers exercisable by the Employer against the said Vendor / Contractor / Supplier and to forbear or enforce any of the terms and conditions relating to the said Contract and we shall not be relieved from our liability by reason of any such variation, or extension being granted to the said Vendor / Contractor / Supplier or for any forbearance, act or omission on the part of the Employer or any indulgence by the Employer to the said Vendor / Contractor / Supplier or by any such matter or thing whatsoever which under the law relating to sureties would but for this provision have effect of so relieving us.

The Bank also agrees that the Employer at its option shall be entitled to enforce this Guarantee against the Bank as a principal debtor, in the first instance without proceeding against the Vendor / Contractor / Supplier and notwithstanding any security or other guarantee that the Employer may have in relation to the Vendor / Contractor / Supplier 's liabilities.

This Guarantee shall remain in force upto and including.....⁷ and shall be extended from time to time for such period as may be desired by Employer.

This Guarantee shall not be determined or affected by liquidation or winding up, dissolution or change of constitution or insolvency of the Vendor / Contractor / Supplier but shall in all respects and for all purposes be binding and operative until payment of all money payable to the Employer in terms thereof.

Unless a demand or claim under this guarantee is made on us in writing on or before the⁸we shall be discharged from all liabilities under this guarantee thereafter.

We, BANK lastly undertake not to revoke this guarantee during its currency except with the previous consent of the Employer in writing.

Notwithstanding anything to the contrary contained hereinabove:

- a) The liability of the Bank under this Guarantee shall not exceed.....⁶
- b) This Guarantee shall be valid up to⁷
- c) Unless the Bank is served a written claim or demand on or before⁸ all rights under this guarantee shall be forfeited and the Bank shall be relieved and discharged from all liabilities under this guarantee irrespective of whether or not the original bank guarantee is returned to the Bank.

We, _____ Bank, have power to issue this Guarantee under law and the undersigned as a duly authorized person has full powers to sign this Guarantee on behalf of the Bank.

For and on behalf of
(Name of the Bank)

Dated.....

Place of Issue.....

¹ NAME AND ADDRESS OF EMPLOYER I.e Bharat Heavy Electricals Limited

² NAME AND ADDRESS OF THE VENDOR /CONTRACTOR / SUPPLIER.

³ DETAILS ABOUT THE NOTICE OF AWARD/CONTRACT REFERENCE

⁴ CONTRACT VALUE

⁵ PROJECT/SUPPLY DETAILS

⁶ BG AMOUNT IN FIGURES AND WORDS

⁷ VALIDITY DATE

⁸ DATE OF EXPIRY OF CLAIM PERIOD

Certificate by Chartered Accountant on letterhead

This is to certify that M/s _____
(hereinafter referred to as 'enterprise') having PAN Number _____ and
UDYAM Registration Number _____, registered office at _____
_____ is falling under the category
_____ (**Micro / Small / Medium**) under MSMED Act 2006. (Copy of UDYAM Registration
Certificate to be enclosed).

The said classification of _____ (**Micro / Small / Medium**) is arrived at based on the
Notifications / guidelines / clarifications issued under Micro, Small and Medium Enterprises
Development Act, 2006 including the notification S.O.2119 (E) dated 26th June 2020.

The Investment of the enterprise in Plant and Machinery or Equipment as at 31st March
2020 as per Clause 4 of the Notification is _____ (Rupees in Lakhs).

The turnover of the Enterprise for the period ending 31st March 2020 as per Clause 5
of the Notification is _____ (Rupees in Lakhs).

Date:

(Signature) Name-
Membership number-

Seal of Chartered Accountant with UDIN reference

INTEGRITY PACT**Between**

Bharat Heavy Electricals Ltd. (BHEL), a company registered under the Companies Act 1956 and having its registered office at "BHEL House", Siri Fort, New Delhi - 110049 (India) hereinafter referred to as "The Principal", which expression unless repugnant to the context or meaning hereof shall include its successors or assigns of the ONE PART

and

_____, (description of the party along with address), hereinafter referred to as "The Bidder/ Contractor" which expression unless repugnant to the context or meaning hereof shall include its successors or assigns of the OTHER PART

Preamble

The Principal intends to award, under laid-down organizational procedures, contract/s for _____

_____ (hereinafter referred to as "Contract"). The Principal values full compliance with all relevant laws of the land, rules and regulations, and the principles of economic use of resources, and of fairness and transparency in its relations with its Bidder(s)/ Contractor(s).

In order to achieve these goals, the Principal will appoint panel of Independent External Monitor(s) (IEMs), who will monitor the tender process and the execution of the contract for compliance with the principles mentioned above.

Section 1- Commitments of the Principal

- 1.1 The Principal commits itself to take all measures necessary to prevent corruption and to observe the following principles: -
 - 1.1.1 No employee of the Principal, personally or through family members, will in connection with the tender for, or the execution of a contract, demand, take a promise for or accept, for self or third person, any material or immaterial benefit which the person is not legally entitled to.
 - 1.1.2 The Principal will, during the tender process treat all Bidder(s) with equity and reason. The Principal will in particular, before and during the tender process, provide to all Bidder(s) the same information and will not provide to any Bidder(s) confidential/ additional information through which the Bidder(s) could obtain an advantage in relation to the tender process or the contract execution.
 - 1.1.3 The Principal will exclude from the process all known prejudiced persons.
- 1.2 If the Principal obtains information on the conduct of any of its employees which is a penal offence under the Indian Penal Code 1860 and Prevention of Corruption Act 1988 or any other statutory penal enactment, or if there be a substantive suspicion in this regard, the Principal will inform its Vigilance Office and in addition can initiate disciplinary actions.

Section 2 - Commitments of the Bidder(s)/ Contractor(s)

- 2.1 The Bidder(s)/ Contractor(s) commit himself to take all measures necessary to prevent corruption. The Bidder(s)/ Contractor(s) commits himself to observe the following principles during participation in the tender process and during the contract execution.

- 2.1.1 The Bidder(s)/ Contractor(s) will not, directly or through any other person or firm, offer, promise or give to the Principal or to any of the Principal's employees involved in the tender process or the execution of the contract or to any third person any material, immaterial or any other benefit which he/ she is not legally entitled to, in order to obtain in exchange any advantage of any kind whatsoever during the tender process or during the execution of the contract.
- 2.1.2 The Bidder(s)/ Contractor(s) will not enter with other Bidder(s) into any illegal or undisclosed agreement or understanding, whether formal or informal. This applies in particular to prices, specifications, certifications, subsidiary contracts, submission or non-submission of bids or any other actions to restrict competitiveness or to introduce cartelization in the bidding process.
- 2.1.3 The Bidder(s)/ Contractor(s) will not commit any penal offence under the relevant Indian Penal Code (IPC) and Prevention of Corruption Act; further the Bidder(s)/ Contractor(s) will not use improperly, for purposes of competition or personal gain, or pass on to others, any information or document provided by the Principal as part of the business relationship, regarding plans, technical proposals and business details, including information contained or transmitted electronically.
- 2.1.4 Foreign Bidder(s)/ Contractor(s) shall disclose the name and address of agents and representatives in India and Indian Bidder(s)/ Contractor(s) to disclose their foreign principals or associates. The Bidder(s)/ Contractor(s) will, when presenting his bid, disclose any and all payments he has made, and is committed to or intends to make to agents, brokers or any other intermediaries in connection with the award of the contract.
- 2.2 The Bidder(s)/ Contractor(s) will not instigate third persons to commit offences outlined above or be an accessory to such offences.
- 2.3 The Bidder(s)/ Contractor(s) shall not approach the Courts while representing the matters to IEMs and shall await their decision in the matter.

Section 3 - Disqualification from tender process and exclusion from future contracts

If the Bidder(s)/ Contractor(s), before award or during execution has committed a transgression through a violation of Section 2 above, or acts in any other manner such as to put his reliability or credibility in question, the Principal is entitled to disqualify the Bidder(s)/ Contractor(s) from the tender process, terminate the contract, if already awarded, exclude from future business dealings and/ or take action as per the separate "Guidelines on Banning of Business dealings with Suppliers/ Contractors", framed by the Principal.

Section 4 - Compensation for Damages

- 4.1 If the Principal has disqualified the Bidder (s) from the tender process before award / order acceptance according to Section 3, the Principal is entitled to demand and recover the damages equivalent to Earnest Money Deposit/ Bid Security.
- 4.2 If the Principal is entitled to terminate the Contract according to Section 3, or terminates the Contract in application of Section 3 above, the Bidder(s)/ Contractor (s) transgression through a violation of Section 2 above shall be construed breach of contract and the Principal shall be entitled to demand and recover from the Contractor an amount equal to 5% of the contract value or the amount equivalent to Security Deposit/ Performance Bank Guarantee, whichever is higher, as damages, in addition to and without prejudice to its right to demand and recover compensation for any other loss or damages specified elsewhere in the contract.

Section 5 - Previous Transgression

- 5.1 The Bidder declares that no previous transgressions occurred in the last 3 (three) years with any other company in any country conforming to the anti-corruption approach or with any other Public Sector Enterprise in India that could justify his exclusion from the tender process.
- 5.2 If the Bidder makes incorrect statement on this subject, he can be disqualified from the tender process or the contract, if already awarded, can be terminated for such reason or action can be taken as per the separate "Guidelines on Banning of Business dealings with Suppliers/ Contractors", framed by the Principal.

Section 6 - Equal treatment of all Bidder (s)/ Contractor (s) / Sub-contractor (s)

- 6.1 The Principal will enter into Integrity Pacts with identical conditions as this Integrity Pact with all Bidders and Contractors.
- 6.2 In case of Sub-contracting, the Principal Contractor shall take the responsibility of the adoption of Integrity Pact by the Sub-contractor(s) and ensure that all Sub-contractors also sign the Integrity Pact.
- 6.3 The Principal will disqualify from the tender process all Bidders who do not sign this Integrity Pact or violate its provisions.

Section 7 - Criminal Charges against violating Bidders/ Contractors /Subcontractors

If the Principal obtains knowledge of conduct of a Bidder, Contractor or Subcontractor, or of an employee or a representative or an associate of a Bidder, Contractor or Subcontractor which constitutes corruption, or if the Principal has substantive suspicion in this regard, the Principal will inform the Vigilance Office.

Section 8 -Independent External Monitor(s)

- 8.1 The Principal appoints competent and credible panel of Independent External Monitor (s) (IEMs) for this Integrity Pact. The task of the IEMs is to review independently and objectively, whether and to what extent the parties comply with the obligations under this Integrity Pact.
- 8.2 The IEMs are not subject to instructions by the representatives of the parties and performs his functions neutrally and independently. He reports to the CMD, BHEL.
- 8.3 The IEMs shall be provided access to all documents/ records pertaining to the Contract, for which a complaint or issue is raised before them as and when warranted. However, the documents/records/information having National Security implications and those documents which have been classified as Secret/Top Secret are not to be disclosed.
- 8.4 The Principal will provide to the IEMs sufficient information about all meetings among the parties related to the Contract provided such meetings could have an impact on the contractual relations between the Principal and the Contractor. The parties offer to the IEMs the option to participate in such meetings.

- 8.5 The advisory role of IEMs is envisaged as that of a friend, philosopher and guide. The advice of IEMs would not be legally binding and it is restricted to resolving issues raised by a Bidder regarding any aspect of the tender which allegedly restricts competition or bias towards some Bidders. At the same time, it must be understood that IEMs are not consultants to the Management. Their role is independent in nature and the advice once tendered would not be subject to review at the request of the organization.
- 8.6 For ensuring the desired transparency and objectivity in dealing with the complaints arising out of any tendering process or during execution of Contract, the matter should be examined by the full panel of IEMs jointly, who would look into the records, conduct an investigation, and submit their joint recommendations to the Management.
- 8.7 The IEMs would examine all complaints received by them and give their recommendations/ views to the CMD, BHEL at the earliest. They may also send their report directly to the CVO, in case of suspicion of serious irregularities requiring legal/ administrative action. Only in case of very serious issue having a specific, verifiable Vigilance angle, the matter should be reported directly to the Commission. IEMs will tender their advice on the complaints within 30 days.
- 8.8 The CMD, BHEL shall decide the compensation to be paid to the IEMs and its terms and conditions.
- 8.9 IEMs should examine the process integrity, they are not expected to concern themselves with fixing of responsibility of officers. Complaints alleging mala fide on the part of any officer of the Principal should be looked into by the CVO of the Principal.
- 8.10 If the IEMs have reported to the CMD, BHEL, a substantiated suspicion of an offence under relevant Indian Penal Code / Prevention of Corruption Act, and the CMD, BHEL has not, within reasonable time, taken visible action to proceed against such offence or reported it to the Vigilance Office, the IEMs may also transmit this information directly to the Central Vigilance Commissioner, Government of India.
- 8.11 After award of work, the IEMs shall look into any issue relating to execution of Contract, if specifically raised before them. As an illustrative example, if a Contractor who has been awarded the Contract, during the execution of Contract, raises issue of delayed payment etc. before the IEMs, the same shall be examined by the panel of IEMs. Issues like warranty/ guarantee etc. shall be outside the purview of IEMs.
- 8.12 However, the IEMs may suggest systemic improvements to the management of the Principal, if considered necessary, to bring about transparency, equity and fairness in the system of procurement.
- 8.13 The word 'Monitor' would include both singular and plural.

Section 9 - Pact Duration

- 9.1 This Integrity Pact shall be operative from the date this Integrity Pact is signed by both the parties till the final completion of contract for successful Bidder, and for all other Bidders 6 months after the Contract has been awarded. Any violation of the same would entail disqualification of the bidders and exclusion from future business dealings.
- 9.2 If any claim is made/ lodged during currency of this Integrity Pact, the same shall be binding and continue to be valid despite the lapse of this Pact as specified above, unless it is discharged/ determined by the CMD, BHEL.

Section 10 - Other Provisions

- 10.1 This Integrity Pact is subject to Indian Laws and exclusive jurisdiction shall be of the competent Courts as indicated in the Tender or Contract, as the case may be.
- 10.2 Changes and supplements as well as termination notices need to be made in writing.
- 10.3 If the Bidder(s)/ Contractor(s) is a partnership or a consortium or a joint venture, this Integrity Pact shall be signed by all partners of the partnership or joint venture or all consortium members.
- 10.4 Should one or several provisions of this Integrity Pact turn out to be invalid, the remainder of this Integrity Pact remains valid. In this case, the parties will strive to come to an agreement to their original intentions.
- 10.5 Only those bidders / contractors who have entered into this Integrity Pact with the Principal would be competent to participate in the bidding. In other words, entering into this Integrity Pact would be a preliminary qualification.
- 10.6 In the event of any dispute between the Principal and Bidder(s)/ Contractor(s) relating to the Contract, in case, both the parties are agreeable, they may try to settle dispute through Mediation before the panel of IEMs in a time bound manner. In case, the dispute remains unresolved even after mediation by the panel of IEMs, either party may take further action as the terms & conditions of the Contract. The fees/expenses on dispute resolution through mediation shall be shared by both the parties. Further, the mediation proceedings shall be confidential in nature and the parties shall keep confidential all matters relating to the mediation proceedings including any settlement agreement arrived at between the parties as outcome of mediation. Any views expressed, suggestions, admissions or proposals etc. made by either party in the course of mediation shall not be relied upon or introduced as evidence in any further arbitral or judicial proceedings, whether or not such proceedings relate to the dispute that is the subject of mediation proceedings. Neither of the parties shall present IEMs as witness in any Alternative Dispute Resolution or judicial proceedings in respect of the dispute that was subject of mediation.

 For & On behalf of the Principal
 (Office Seal)

 For & On behalf of the Bidder/ Contractor
 (Office Seal)

Place _____
 Date _____

Witness: _____
 (Name & Address) _____

Witness: _____
 (Name & Address) _____

Annexure-X

Restrictions under Rule 144(xi) of General Financial Rules, 2017 amendment dt: 23.07.2020

- I. Any bidder from a country which shares a land border with India will be eligible to bid in this tender only if the bidder is registered with the Competent Authority.
- II. "Bidder" (including the term 'tenderer', 'consultant' or 'service provider' in certain contexts) means any person or firm or company, including any member of a consortium or joint venture (that is an association of several persons, or firms or companies), every artificial juridical person not falling in any of the descriptions of bidders stated hereinbefore, including any agency branch or office controlled by such person, participating in a procurement process.
- III. "Bidder from a country which shares a land border with India" for the purpose of this Order means :-
 - a. An entity incorporated, established or registered in such a country; or
 - b. A subsidiary of an entity incorporated, established or registered in such a country; or
 - c. An entity substantially controlled through entities incorporated, established or registered in such a country; or
 - d. An entity whose *beneficial owner* is situated in such a country; or
 - e. An Indian (or other) agent of such an entity; or
 - f. A natural person who is a citizen of such a country; or
 - g. A consortium or joint venture where any member of the consortium or joint venture falls under any of the above
- IV. The *beneficial owner* for the purpose of (iii) above will be as under:
 1. In case of a company or Limited Liability Partnership, the beneficial owner is the natural person(s), who, whether acting alone or together, or through one or more juridical person, has a controlling ownership interest or who exercises control through other means.

Explanation--

 - a. "Controlling ownership interest" means ownership of or entitlement to more than twenty-five per cent of shares or capital or profits of the company;
 - b. "Control" shall include the right to appoint majority of the directors or to control the management or policy decisions including by virtue of their shareholding or management rights or shareholders agreements or voting agreements;
 2. In case of a partnership firm, the beneficial owner is the natural person(s) who, whether acting alone or together, or through one or more juridical person, has ownership of entitlement to more than fifteen percent of capital or profits of the partnership;

3. In case of an unincorporated association or body of individuals, the beneficial owner is the natural person(s), who, whether acting alone or together, or through one or more juridical person, has ownership of or entitlement to more than fifteen percent of the property or capital or profits of such association or body of individuals;
 4. Where no natural person is identified under (1) or (2) or (3) above, the beneficial owner is the relevant natural person who holds the position of senior managing official;
 5. In case of a trust, the identification of beneficial owner(s) shall include identification of the author of the trust, the trustee, the beneficiaries with fifteen percent or more interest in the trust and any other natural person exercising ultimate effective control over the trust through a chain of control or ownership.
- V. An Agent is a person employed to do any act for another, or to represent another in dealings with third person.



ಭಾರತ್ ಹೆವಿ ಎಲೆಕ್ಟ್ರಿಕಲ್ಸ್ ಲಿಮಿಟೆಡ್
 भारत हेवी इलेक्ट्रिकल्स लिमिटेड

Bharat Heavy Electricals Ltd.,
(A Government of India undertaking)
Electronics Division

PB 2606 , Mysore Road Bangalore , 560026 INDIA

CE: PR: 002- Rev 03

GENERAL COMMERCIAL CONDITIONS FOR CONTRACT

These 'General Commercial Conditions for Contract for Purchase' herein after referred to as GCC apply to all enquiries, tenders, requests for quotations, orders, contracts and agreements concerning the supply of goods and the rendering of related services (hereinafter referred to as "deliveries") to Bharat Heavy Electricals Limited and any of its units, regions or divisions (hereinafter referred to as "BHEL" or the Purchaser) or its projects/ customers.

Any deviations from or additions to these GCC require BHEL's express written consent. The general terms of business or sale of the vendor shall not apply to BHEL. Acceptance, receipt of shipments or services or effecting payment shall not mean that the general terms of business or sale of the vendor have been accepted.

Orders, agreements and amendments thereto shall be binding if made or confirmed by BHEL in writing. Only the Purchasing department of BHEL is authorized to issue the Purchase Order or any amendment thereof.

Definitions: Throughout these conditions and in the specifications, the following terms shall have the meanings assigned to them, unless the subject matter or the context requires otherwise.

- 'The Purchaser' means Bharat Heavy Electricals Limited, Electronics division, Mysore road, Bangalore 560 026, a Unit of Bharat Heavy Electricals Limited (A Govt. of India Undertaking) incorporated under the Companies Act having its registered office at BHEL House, Siri Fort, New Delhi-110049, India and shall be deemed to include its successors and assigns. It may also be referred to as BHEL.
- 'The vendor' means the person, firm, company or organization on whom the Purchase Order is placed and shall be deemed to include the vendor's successors, representative heirs, executors and administrator as the case may be. It may also be referred to as Seller, Contractor or Supplier.
- 'Contract' shall mean and include the Purchase Order incorporating various agreements, viz. tender/ RFQ, offer, letter of intent/acceptance/ award, the General Conditions of Contract and Special Conditions of Contract for Purchase, Specifications, Inspection/ Quality Plan, Schedule of Prices and Quantities, Drawings, if any enclosed or to be provided by BHEL or his authorized nominee and the samples or patterns if any to be provided under the provisions of the contract.
- 'Parties to the Contract' shall mean the 'The Vendor' and the Purchaser as named in the main body of the Purchase Order.

Order of Precedence:

In case of any inconsistency or contradiction between any of the documents, the order of precedence shall be Purchase Order, LOI / LOA, Special Conditions of Contract and General Conditions of Contract for commercial conditions; and specific agreement on technical conditions, RFQ/offer and specification for Technical Conditions.

Interpretation:

In the contract, except where the context requires otherwise:

- words indicating one gender include all genders;
- words indicating the singular also include the plural and words indicating the plural also include the singular;

- c) provisions including the word "agree", "agreed" or "agreement" require the agreement to be recorded in writing, and
- d) "Written" or "in writing" means hand-written, type-written, printed or electronically made, and resulting in a permanent record.

Applicable Conditions:

1. **Price Basis:** All prices shall be firm until the purchase order is executed / completed in all respects. No price variations / escalation shall be permitted.
2. **Ordering and confirmation of Order:** Vendor shall send the order acceptance on their company letter head/ through e-mail within a week from the date of receipt of Purchase Order or such other period as specified/ agreed by BHEL. BHEL reserves the right to revoke the order placed if the order confirmation differs from the original order placed. The acceptance of goods/services/supplies by BHEL as well as payments made in this regard shall not imply acceptance of any deviations.
The purchase order will be deemed to have been accepted if no communication to the contrary is received within one week (or the time limit as specified/agreed by BHEL) from the date of receipt of the purchase order.
3. **Documentation:** After receipt of Purchase Order, vendor should submit necessary documents (if & as applicable) like drawings specified, bill of materials, datasheets, catalogues, quality plan, test procedure, type test report, O & M Manuals and/or any other relevant documents as per Specification/Purchase Order, as and when required by BHEL/ Customer.
At any stage within the contract period, the vendor shall notify of any error, fault or other defect found in BHEL's documents / specifications or any other items for reference. If and to the extent that (taking account of cost and time) any vendor exercising due care would have discovered the error, fault or other defect when examining the documents/specifications before submitting the tender, the time for completion shall not be extended. However if errors, omissions, ambiguities, inconsistencies, inadequacies or other defects are found in the vendor's documents, they shall be corrected at his cost, notwithstanding any consent or approval.
4. **Penalty:**
 - a. **For delay in documentation:** In the event of delay in submission of complete set of specified documents ((like drawings, bill of materials, datasheets, catalogues, quality plan etc. as called in tender specifications including soft copies wherever applicable) in required sets beyond two(02) weeks (or as agreed/indicated in the SCC/Purchase Order) from the date of receipt of Purchase Order (by email), penalty at 0.5% (half percent) per week or part thereof, limited to a maximum of 5% (five percent) of the basic material value of the Purchase Order will be applicable.

Penalty for delayed documentation if applicable, shall be deducted at the time of first supply payment. If penalty is applicable for duration of less than a week, penalty @ 0.5% (half percent) of the basic material value will be deducted. GST as applicable will be recovered along with penalty amount.
 - b. **For delay in delivery:** In the event of delay in agreed contractual delivery as per Purchase Order, penalty @ 0.5 % (half percent) per week or part thereof but limited to a max of 10% (ten percent) value of undelivered portion (basic material cost) will be applicable. Delivery will commence from the date of issue of Manufacturing clearance along with approved document. The date for which Inspection call is issued by vendor along with test certificates / test reports / Certificate of Conformance / calibration reports, as proof of completion of manufacturing will be treated as date of deemed delivery for penalty calculation. In the absence of furnishing such document indicated above as proof of completion of manufacturing along with inspection call, actual date of inspection will be considered as date of deemed delivery and BHEL will not be responsible for delay in actual date of inspection.

Penalty for delayed delivery if applicable, shall be deducted at the time of first supply payment. If penalty is applicable for duration of less than a week, penalty @ 0.5% (half percent) of the basic material value will be deducted. GST as applicable will be recovered along with penalty amount.

5. Contract variations (Increase or decrease in the scope of supply): BHEL may vary the contracted scope as per requirements at site. If vendor is of the opinion that the variation has an effect on the agreed price or delivery period, BHEL shall be informed of this immediately in writing along with technical details. Where unit rates are available in the Contract, the same shall be the basis for such additional work. Vendor shall not perform additional work before BHEL has issued written instructions/ amendment to the Purchase Order to that effect. The work which the vendor should have or could have anticipated in terms of delivering the service(s) and functionality (i.e.) as described in this agreement, or which is considered to be the result of an attributable error on the vendor's part, shall not be considered additional work.
6. Inspection: Prior written notice of at least 10 days shall be given along with internal test certificates/COC and applicable test certificates. Materials will be inspected by BHEL-EDN-QS/CQS or BHEL nominated Third Party Inspection Agency (TPIA) or BHEL authorized Inspection Agency or Customer / Consultant or jointly by BHEL & Customer / consultant. All tests have to be conducted as applicable in line with approved Quality plan or QA Checklist or Purchase specification and original reports shall be furnished to BHEL-EDN, Bangalore for verification/acceptance for issue of dispatch clearance. BHEL reserves the right for conducting repeat test, if required.
All costs related to inspections & re-inspections shall be borne by vendor. Whether the Contract provides for tests on the premises of the vendor or any of his Sub-contractor/s, vendor shall be responsible to provide such assistance, labour, materials, electricity, fuels, stores, apparatus, instruments as may be required and as may be reasonably demanded to carry out such tests efficiently. Cost of any type test or such other special tests shall be borne by BHEL only if specifically agreed to in the purchase order.
7. Transit Insurance: Transit insurance coverage between vendor's works and project site shall be to the account of BHEL, unless specifically agreed otherwise. However, vendor shall send intimation directly to insurance agency (as mentioned in dispatch instructions issued by BHEL) through fax/courier/e-mail, immediately on dispatch of goods for covering insurance. A copy of such intimation sent by vendor to insurance agency shall be given to BHEL along with dispatch documents. Dispatch documents will be treated as incomplete without such intimation copy. BHEL shall not be responsible for sending intimations to insurance agency on behalf of the vendor.
8. Mode of dispatch:
Indigenous Scope: By road on Door Delivery Consignee Copy attached basis through your approved transporter (unless otherwise indicated in Dispatch Instructions), only on receipt of Despatch Clearance from BHEL.
Imported Scope: By Air/Sea through BHEL approved Freight Forwarder/supplier approved Consolidator respectively as per agreed contractual terms, only on receipt of Dispatch Clearance from BHEL.
9. Changes in Statutory levies:
If any rates of Tax are increased or decreased, a new Tax is introduced, an existing Tax is abolished, or any change in interpretation or application of any Tax occurs in the course of the execution of Contract, which was or will be assessed on the bidder in connection with performance of the Contract, an equitable adjustment of the Contract Price shall be made to fully take into account any such change by addition to the Contract Price or deduction there from, as the case may be. However, these adjustments would be restricted to direct transactions between BHEL and the bidder /agent of foreign bidder (if applicable). These adjustments shall not be applicable on procurement of raw materials, intermediary components etc. by the bidder /agent.
10. Availing duty/tax exemption benefits by bidder, wherever applicable: BHEL shall issue the required Certificate/s, as per relevant policies of the Govt. of India, to facilitate the bidders to avail any such benefits under the Contract. In case of failure of the bidders to receive the benefits partly or fully from the Govt. of India and/or in case of any delay in receipt of such benefits, BHEL shall neither be liable nor responsible in any manner whatsoever.

11. Taxes against sub-vendor dispatches: All taxes/levies, as applicable in respect of all components, equipments and material to be despatched directly from the sub-vendor's works to Site irrespective of the fact whether such taxes and levies are assessable and chargeable on Vendor or the BHEL, shall be to the vendor's account and no separate claim in this regard will be entertained by BHEL.
12. High Sea Sales (HSS): Customs clearance of the consignment landed on Indian Sea/Air ports will be done by BHEL based on the original HSS documents provided by vendors.
Any delay in submission of complete/correct HSS documents to BHEL may incur demurrage charges. All demurrage charges on account of incomplete /incorrect HSS documents submission by vendor will be to vendor's account and all such charges will be recovered from any of the available vendor bills with BHEL.
13. Packaging and dispatch: The Seller shall package the goods safely and carefully and pack them suitably in all respects considering the peculiarity of the material for normal safe transport by Sea/ Air / Rail/ Road to its destination suitably protected against loss, damage, corrosion in transit and the effect of tropical salt laden atmosphere. The packages shall be provided with fixtures/ hooks and sling marks as may be required for easy and safe handling. If any consignment needs special handling instruction, the same shall be clearly marked with standard symbols / instructions. Hazardous material should be notified as such and their packing, transportation and other protection must conform to relevant regulations.
The packing, shipping, storage and processing of the goods must comply with the prevailing legislation and regulations concerning safety, the environment and working conditions. Any Imported/Physical Exports items packed with raw/ solid wood packing material should be treated as per ISPM – 15 (fumigation) and accompanied by Phytosanitary/ Fumigation certificate. If safety information sheets (MSDS – Material Safety Data Sheet) exist for an item or the packaging, vendor must provide this information without fail along with the consignment.
Each package must be marked with Consignee name, Purchase order number, Package number, Gross weight and net weight, dimensions (LxBxH) and Seller's name. Packing list of goods inside each package with PO item number and quantity must also be fixed securely outside the box to indicate the contents of each box. Total number of packages in the consignment must also be indicated in the packing list.
Separate packing & identification of items should be as follows.
1. Main Scope - All items must be tagged with part no. & item description.
2. Commissioning accessories/spares - All items must be tagged with part no. & item description.
3. Mandatory spares - All items must be tagged with part no. & item description.
Nevertheless, vendor shall adhere to dispatch & packing instructions issued by BHEL at the time of dispatch.
14. Assignment of Rights & Obligations; Subcontracting: Vendor is not permitted to subcontract the delivery or any part thereof to third party or to assign the rights and obligations resulting from this agreement in whole or in part to third parties without prior written permission from BHEL. Any permission or approval given by the BHEL shall, however, not absolve the vendor of the responsibility of his obligations under the Contract.
15. Progress report: Vendor shall render such report as to the progress of work and in such form as may be called for by the concerned purchase officer from time to time. The submission and acceptance of such reports shall not prejudice the rights of BHEL in any manner.
16. Non-disclosure and Information Obligations: Vendor shall provide with all necessary information pertaining to the goods as it could be of importance to BHEL. Vendor shall not reveal any specified confidential information that may be divulged by BHEL to Vendor's employees not involved with the tender/ contract & its execution and delivery or to third parties, unless BHEL has agreed to this in writing beforehand. Vendor shall not be entitled to use the BHEL name in advertisements and other commercial publications without prior written permission from BHEL.
17. Cancellation /Termination of contract: BHEL shall have the right to completely or partially terminate the agreement by means of written notice to that effect. Termination of the Contract, for whatever reason, shall be without prejudice to the rights of the parties accrued under the Contract up to the time of termination.
BHEL shall have the right to cancel/foreclose the Order/ Contract, wholly or in part, in case it is constrained to do so on account of any decline, diminution, curtailment or stoppage of the business.

18. Risk Purchase Clause: In case of failure of supplier, BHEL at its discretion may make purchase of the materials / services not supplied / rendered in time at the RISK & COST of the supplier. Under such situation, the supplier who fails to supply the goods in time shall be wholly liable to make good to BHEL any loss due to risk purchase.

In case of items demanding services at site like erection and commissioning, vendor should send his servicemen/representatives within 7 days from the service call. In case a vendor fails to attend to the service call, BHEL at its discretion may also make arrangements to attend such service by other parties at the **RISK & COST** of the supplier. Under such situation the supplier who fails to attend the service shall be wholly liable to make good to BHEL any loss due to risk purchase/service including additional handling charges due to the change.

19. Shortages: In the event of shortage on receipt of goods and/or on opening of packages at site, all such shortages, caused by supplier's act or omission, shall be made good at free of cost within a reasonable time that BHEL may allow from such intimation.

Transit Damages: In the event of receipt of goods in damaged condition or having found them so upon opening of packages at site, supplier shall make good of all such damages within a reasonable time from such intimation by BHEL. In case BHEL raises an insurance claim, the cost of material limited to insurance settled amount less handling charges will be reimbursed to supplier.

20. Remedial work: Notwithstanding any previous test or certification, BHEL may instruct the vendor to remove and replace materials/goods or remove and re-execute works/services which are not in accordance with the purchase order. Similarly BHEL may ask the vendor to supply materials or to execute any services which are urgently required for any safety reasons, whether arising out of or because of an accident, unforeseeable event or otherwise. In such an event, Vendor shall provide such services within a reasonable time as specified by BHEL.

21. Indemnity Clause: Vendor shall comply with all applicable safety regulations and take care for the safety of all persons involved. Vendor is fully responsible for the safety of its personnel or that of his subcontractor's men / property, during execution of the Purchase Order and related services. All statutory payments including PF, ESI or other related charges have to be borne by the vendor. Vendor is fully responsible for ensuring that all legal compliances are followed in course of such employment. Vendor shall fully indemnify and keep indemnified BHEL against all claims of whatsoever nature arising during the course and out of execution of this Order/Contract.

22. Product Information, Drawings and Documents: All specified drawings, technical documents or other technical information received by Vendor from BHEL or vice versa shall not, without the consent of the other party, be used for any other purpose than that for which they were provided. They may not, without the consent of the Disclosing party, otherwise be used or copied, reproduced, transmitted or communicated to third parties. All information and data contained in general product documentation, whether in electronic or any other form, are binding only to the extent that they are by reference expressly included in the contract.

Vendor, as per agreed date/s but not later than the date of delivery, provide free of charge information and drawings which are necessary to permit and enable BHEL to erect, commission, operate and maintain the product. Such information and drawings shall be supplied in as many numbers of copies as may be agreed upon.

All intellectual properties, including designs, drawings and product information etc. exchanged during the formation and execution of the Contract shall continue to be the property of the disclosing party.

23. Intellectual Property Rights, Licenses: If any Patent, design, Trade mark or any other intellectual property rights apply to the delivery (goods/related service) or accompanying documentation shall be the exclusive property of the Vendor and BHEL shall be entitled to the legal use thereof free of charge by means of a non-exclusive, worldwide, perpetual license. All intellectual property rights that arise during the execution of the Purchase Order/ contract for delivery by vendor and/or by its employees or third parties involved by the vendor for performance of the agreement shall belong to BHEL. Vendor shall perform everything necessary to obtain or establish the above mentioned rights. The Vendor guarantees that the delivery does not infringe on any of the intellectual property rights of third parties. The Vendor shall do everything

necessary to obtain or establish the alternate acceptable arrangement pending resolution of any (alleged) claims by third parties. The Vendor shall indemnify BHEL against any (alleged) claims by third parties in this regard and shall reimburse BHEL for any damages suffered as a result thereof.

24. Force Majeure: Notwithstanding anything contained in the purchase order or any other document relevant thereto, neither party shall be liable for any failure or delay in performance to the extent said failures or delays are caused by the "Act of God" and occurring without its fault or negligence, provided that, force majeure will apply only if the failure to perform could not be avoided by the exercise of due care and vendor doing everything reasonably possible to resume its performance.

A party affected by an event of force majeure which may include fire, tempest, floods, earthquake, riot, war, damage by aircraft etc., shall give the other party written notice, with full details as soon as possible and in any event not later than seven (7) calendar days of the occurrence of the cause relied upon. If force majeure applies, dates by which performance obligations are scheduled to be met will be extended for a period of time equal to the time lost due to any delay so caused.

Notwithstanding above provisions, in an event of Force Majeure, BHEL reserves for itself the right to cancel the order/ contract, wholly or partly, in order to meet the overall project schedule and make alternative arrangements for completion of deliveries and other schedules.

25. Warranty:

Wherever required, and so provided in the specifications/ Purchaser Order, the Seller shall ensure that the goods supplied shall comply with the specifications laid down, for materials, workmanship and performance.

Unless otherwise specified in SCC, warranty period shall be applicable for a period of 24 months from the date of delivery of goods or 18 months from the date of commissioning of goods, whichever is earlier.

The warranty period as described above shall apply afresh to replaced, repaired or re-executed parts of a delivery. Unless otherwise specifically provided in the Purchase Order, Vendor's liability shall be co terminus with the expiration of the applicable warranty period.

26. Limitation of Liability: Vendor's liability towards this contract is limited to a maximum of 100% of the contract value and consequential damages are excluded. However the limits of liability will have no effect in cases of criminal negligence or wilful misconduct.

The total liability of Vendor for all claims arising out of or relating to the performance or breach of the Contract or use of any Products or Services or any order shall not exceed the total Contract price.

27. Liability during warranty: Vendor shall arrange replacement / repair of all the defective materials / services under its obligation during the warranty period. The rejected goods shall be taken away by vendor and replaced / repaired. In the event of the vendor's failure to comply, BHEL may take appropriate action including disposal of rejections and replenishment by any other sources at the cost and risk of the vendor. In case, defects attributable to vendor are detected during Warranty period or where the commissioning call is issued within the warranty period, vendor shall be responsible for replacement/ repair of the goods as required by BHEL at vendor's cost even after expiry of warranty period.

Further if the equipment or any part thereof cannot be used by reason of such defect and/or making good of such defect, the warranty period of the equipment or such part, as the case may be, shall be extended by a period equal to the period during which the equipment or such part cannot be used by BHEL because of any of the aforesaid reasons. Upon correction of the defects in the facilities or any part thereof by repair/replacement, such repair/replacement shall have the warranty period for a period of twelve (12) months from the time such replacement/repair of the equipment or any part thereof has been completed.

28. Liability after warranty period: At the end of the warranty, the Vendor's liability ceases except for latent defects. For the purpose of this clause, latent defects shall be the defects inherently lying within the material or arising out of design deficiency which do not manifest themselves during the warranty Period, but later. The Contractor's liability for latent defects warranty for the equipment including spares shall be limited to a period of six months from the end of the warranty period of the respective equipment including spares or first time commissioning, whichever is later but not later than one (01) year from the date of expiry of warranty period.

29. Compliance with Laws: Vendor shall, in performing the contract, comply with all applicable laws. The vendor shall make all remittances, give all notices, pay all taxes, duties and fees, and obtain all permits, licences and approvals, as required by the laws in relation to the execution and completion of the contract and for remedying of any defects; and the Contractor shall indemnify and hold BHEL harmless against and from the consequences of any failure to do so.
30. Settlement of Disputes: Except as otherwise specifically provided in the Purchase Order, decision of BHEL shall be binding on the vendor with respect to all questions relating to the interpretation or meaning of the terms and conditions and instructions herein before mentioned and as to the completion of supplies/work/services, other questions, claim, right, matter or things whatsoever in any way arising out of or relating to the contract, instructions, orders or these conditions or otherwise concerning the supply or the execution or failure to execute the order, whether arising during the schedule of supply/work or after the completion or abandonment thereof. Any disputes or differences among the parties shall to the extent possible be settled amicably between the parties thereto, failing which the disputed issues shall be settled through arbitration. Vendor shall continue to perform the contract, pending settlement of dispute(s).
31. Arbitration Clause in case of Contract with vendors other than Public Sector Enterprise (PSE) or a Government Department:

Arbitration & Conciliation:

The parties shall attempt to settle any disputes or difference arising out of the formation, breach, termination, validity or execution of the Contract; or, the respective rights and liabilities of the parties; or, in relation to interpretation of any provision of the Contract; or, in any manner touching upon the Contract, or in connection with this contract through friendly discussions. In case no amicable settlement can be reached between the parties through such discussions, in respect of any dispute; then, either Party may, by a notice in writing to the other Party refer such dispute or difference to the sole arbitration of an arbitrator appointed by Head of the BHEL–EDN. Such Sole Arbitrator appointed, shall conduct the arbitration in English language.

The Arbitrator shall pass a reasoned award and the award of the Arbitration shall be final and binding upon the Parties.

Subject as aforesaid, the provisions of Arbitration and Conciliation Act 1996 (India) or statutory modifications or re-enactments thereof and the rules made thereunder and for the time being in force shall apply to the arbitration proceedings under this clause. The seat of arbitration shall be Bangalore.

The cost of arbitration shall be borne as decided by the Arbitrator upon him entering the reference.

Subject to the Arbitration Clause as above, the Courts at Bangalore alone shall have exclusive jurisdiction over any matter arising out of or in connection with this Contract.

Notwithstanding the existence or any dispute or differences and/or reference for the arbitration, the parties shall proceed with and continue without hindrance the performance of its obligations under this Contract with due diligence and efficiency in a professional manner except where the Contract has been terminated by either Party in terms of this Contract.

Arbitration Clause in case of Contract with a Public Sector Enterprise (PSE) or a Government Department:

In the event of any dispute or difference relating to the interpretation and application of the provisions of the Contract, such dispute or difference shall be referred by either party for Arbitration to the Sole Arbitrator in the Department of Public Enterprises to be nominated by the Secretary to the Government of India in-charge of the Department of Public Enterprises. The Arbitration and Conciliation Act, 1996 shall not be applicable to arbitration under this clause. The award of the Arbitrator shall be binding upon the parties to the dispute, provided, however, any Party aggrieved by such Award may make further reference for setting aside or revision of the Award to the Law Secretary, Department of Legal Affairs, Ministry of Law and Justice, Government of India. Upon such reference the dispute shall be decided by the Law Secretary or the Special Secretary or Additional Secretary when so authorized by the Law Secretary, whose decision shall bind the Parties hereto finally and conclusively. The Parties to the dispute will share equally the cost of arbitration as intimated by the Arbitrator.'

32. Applicable Laws and Jurisdiction of Courts: Prevailing Indian laws both substantive and procedural, including modifications thereto, shall govern the Contract. Subject to the conditions as aforesaid, the competent courts in Bangalore alone shall have jurisdiction to consider over any matters touching upon this contract.
33. General Terms: That any non-exercise, forbearance or omission of any of the powers conferred on BHEL and /or any of its authorities will not in any manner constitute waiver of the conditions hereto contained in these presents.

That the headings used in this agreement are for convenience of reference only.

That all notices etc., to be given under the Purchase order shall be in writing, type script or printed and if sent by registered post or by courier service to the address given in this document shall be deemed to have been served on the date when in the ordinary course, they would have been delivered to the addressee.



A4 - 10

PRE-QUALIFICATIONS REQUIREMENT FOR
PURCHASE SPECIFICATION PS4102095

PQR-CD-1657-410-001

REV. NO. 00

PAGE 01 OF 02

COPY RIGHT AND CONFIDENTIAL

THE INFORMATION ON THIS DOCUMENT IS THE PROPERTY OF BHARAT HEAVY ELECTRICALS LIMITED. IT MUST NOT BE USED DIRECTLY OR INDIRECTLY IN ANY WAY DETRIMENTAL TO THE INTEREST OF THE COMPANY.

***PRE-QUALIFICATIONS REQUIREMENT
FOR
PURCHASE SPECIFICATION PS4102095***

CHECKED BY

JANAK KUMAR /
BIRENDER NATH SHARMA

APPROVED BY

MALA SIBOO /
PRAKASH D

PREPARED

SURESH B / SISIR
BALAGOPAL

ISSUED

410
ENGG

DATE

16.05.2022



A4 - 10

PRE-QUALIFICATIONS REQUIREMENT FOR
PURCHASE SPECIFICATION PS4102095

PQR-CD-1657-410-001

REV. NO. 00

PAGE 02 OF 02

COPY RIGHT AND CONFIDENTIAL
THE INFORMATION ON THIS DOCUMENT IS THE PROPERTY OF BHARAT HEAVY ELECTRICALS LIMITED. IT MUST NOT
BE USED DIRECTLY OR INDIRECTLY IN ANY WAY DETRIMENTAL TO THE INTEREST OF THE COMPANY.

Pre-Qualification Requirements (PQR) for Bidders

1. The bidder should have supplied seismically qualified, fully self-supporting fabricated steel mosaic based Main Control Room Panel for any power plant / process plant control rooms/any other control room application. Seismic qualification is not applicable for Led based LVS system including graphic controller, image hub/matrix switcher.
2. Bidder to provide compliance that similar make/models quoted for this enquiry have been earlier supplied to power plant / process plant control rooms/any other control room application. Bidder should submit relevant PO copies with detailed BoM clearly indicating makes/models supplied as a proof of supply.
3. Along with the documents related to PQR above, following details shall also be included in the Offer :
 - a) Make & Model and datasheet of all the items offered
 - b) Seismic report of the previously supplied panel.Purchaser can match and verify the Data Sheet with the product specifications offered. In case of any unexplained mismatch of technical parameters, the bid is liable for Rejection.
4. Upload Manufacturer authorization: Wherever Authorized Distributors are submitting the bid, Manufacturers Authorization Form (MAF)/Certificate with OEM details such as name, designation, address, e-mail Id and Phone No. required to be furnished along with the bid.
5. Details of Manufacturing, testing & inspection facility.
6. If there are any queries regarding specification, it is bidder's responsibility to get it clarified from the purchaser before submitting the offer.
7. Final acceptance of the Bidder shall be subject to End Customer approval.

Important note: In case Bidder does not submit details mentioned in above clauses or meet the requirements of Pre-qualification requirements, Offer will be summarily rejected and bidder's technical offers/proposals will not be evaluated.



A4-10

PURCHASE SPECIFICATION

LVS CONTROL PANEL
FOR PCPTF AT TARAPUR

PS4102095

REV No. : 00

Page 1 of 20

COPYRIGHT AND CONFIDENTIAL
The information contained in this document is the property of BHARAT HEAVY ELECTRICALS LIMITED
This must not be used directly or indirectly, in any manner detrimental to the interest of the company

PROJECT : PCP TEST FACILITY AT TARAPUR
PRODUCT : LVS CONTROL PANEL
CUSTOMER : M/S NPCIL

TITLE
PURCHASE SPECIFICATION
LVS CONTROL PANEL
FOR PCPTF AT TARAPUR

Dept Code
410

DRN.	NAME	SIGN	DATE
PREPARED	SURESH B / SISIR BALAGOPAL		16.05.2022
CHECKED	JANAK KUMAR / BIRENDER NATH SHARMA		16.05.2022
APPROVED	MALA SIBOO / PRAKASH D	-sd-	16.05.2022



A4-10

PURCHASE SPECIFICATION
LVS CONTROL PANEL
FOR PCPTF AT TARAPUR

PS4102095

REV No. : 00

Page 2 of 20

REVISION HISTORY SHEET

REV No.	DATE	NATURE OF CHANGE	REASON	PREPARED BY	CHECKED BY	REVIEWED BY
00	16.05.2022	FIRST ISSUE	---	SB/ SB	JK/ BNS	MS/ DP

COPYRIGHT AND CONFIDENTIAL
The information contained in this document is the property of **BHARAT HEAVY ELECTRICALS LIMITED**
This must not be used directly or indirectly, in any manner detrimental to the interest of the company



A4-10

PURCHASE SPECIFICATION

LVS CONTROL PANEL FOR PCPTF AT TARAPUR

PS4102095

REV No. : 00

Page 3 of 20

1. SCOPE:

This specification covers the requirements of manufacturing, assembly, wiring, inspection & testing, supply and erection & commissioning support of LVS control panel. The main scope includes (but not limited to):

- Supply of fully self-supporting fabricated steel assembled and wired panels
- Seismically qualified equipment/devices mounted on LVS control panel as per requirement.
- All specified tests as per quality plan.
- Submission for approval of documents as listed elsewhere in this specification.
- Site support as per specified requirements

2. LVS PANEL REQUIREMENT:

Sl. No.	Panel No.	Panel Description
1	66320-PL-6	Large Video Screen Panel

3. The various applicable documents required and to be complied for the above scope are listed in Annexure-1. Any other documents if required for completion of the design and manufacturing will be furnished later.

4. Paint Shades for the panel and mosaic tiles shall be Light Grey RAL-7035. For the panels, both internal and external surfaces shall have the same paint shade as above.

5. Documents to be submitted for approval are as follows (but not limited to):

- Data sheets of raw materials and individual components of each type
- Welding Procedure Specifications (WPS), Procedure Qualification Records (PQR) & Welder Performance Qualifications (WPQ)
- Painting Procedure
- Quality Assurance Plan (QAP) for raw-materials, components and assembled panels as required by specifications
- Acceptance Test Procedure (ATP)
- GA and Bill of Materials of the panel
- Structural drawings for the panels
- Name plate drawing
- Wiring Diagrams (WDs) for the panel
- Seismic Test Procedure (If Applicable)

COPYRIGHT AND CONFIDENTIAL
The information contained in this document is the property of BHARAT HEAVY ELECTRICALS LIMITED
This must not be used directly or indirectly, in any manner detrimental to the interest of the company



A4-10

PURCHASE SPECIFICATION LVS CONTROL PANEL FOR PCPTF AT TARAPUR

PS4102095

REV No. : 00

Page 4 of 20

COPYRIGHT AND CONFIDENTIAL
The information contained in this document is the property of BHARAT HEAVY ELECTRICALS LIMITED
This must not be used directly or indirectly, in any manner detrimental to the interest of the company

- 6.** Type Tests of raw-materials / components as called for in the specifications or as per approved QAP are to be conducted.
However, type test reports of items (same make & model) which were supplied to M/s NPCIL earlier, if available, shall be valid, subject to acceptance by M/s NPCIL.
- 7.** Dimensions of the panel shown in layout drawing (PCPTF/66320/2002/GA REV 01) is indicative. LVS control panel has to be designed, suitable for mounting 75 inch (diagonal) LVS in the vertical portion of the panel along with other major components as per the layout drawing. Refer Annexure-2 for details of LVS.
- 8.** The panel structure has to be seismically qualified or the offered panel structure shall be similar to that of the seismically qualified panel of dimensions & structure as shown in PCPTF/66320/2002/GA REV 01.
- 9.** Components used in the LVS control panel have to be seismically qualified. In case components of same make and model that are being offered have been successfully tested and supplied for KAPP-3&4 / RAPP-7&8 projects earlier, then reports of such tests will be valid, subject to NPCIL acceptance. However, in case any particular make and model of item has not been seismically qualified, the same has to be separately qualified by Shake Table Test if so required by M/S NPCIL. This aspect shall be built in the offer.
- Note:** Seismic qualification is not applicable for LED based LVS system including graphic controller, image hub/matrix switcher.
- 10.** LED based LVS system including graphic controller, image hub/matrix switcher shall be housed in LVS control panel. Refer Annexure-2 for requirements of LED based LVS system. Clause wise compliance to be provided for Annexure-2 ALONG WITH TECHNICAL BID. Wiring, networking, TBS, components like MCBs, fuses etc. to be provided as required.
- 11.** LED screen shall be flush mounted with the panel. After inspection of the entire panel is completed, LED screen shall be removed and packed separately before dispatching to site.
- 12.** Training on operation and maintenance for BHEL and Customer (End User) shall be provided.
- 13.** Erection and commissioning of LVS system including LVS screen, controllers and related accessories are in the scope of bidder.
- 14.** Site modification work like addition/deletion of controls & indications, associated addition/deletion in wiring, modifications in existing components in the panel, if any, is in the scope of vendor.
- 15.** List of spare items mentioned in Annexure-5 to be supplied as loose items and unit price for the same shall be provided. Make & model of the items shall be same as that of the items mounted in the panel.



A4-10

PURCHASE SPECIFICATION
LVS CONTROL PANEL
FOR PCPTF AT TARAPUR

PS4102095

REV No. : 00

Page 5 of 20

ANNEXURE-1

Sr. No	Document number	Description
1	PC-E-314	Technical specification on Main control room panels
2	PCPTF/66320/2002/COM REV 00	List of major components for 66320-PL-6
3	PCPTF/66320/2002/GA REV 01	Layout Drawing for 66320-PL-6 (Dimensions are indicative).
4	PP-E-2061	Tech. Specification for Requirements of Components for Instrumentation Items
5	PC-E-298	Instantaneous Relays
6	PC-E-318	Indicating Lamp Assemblies
7	PC-E-319 (Pg 45 only)	Typical Window Engraving Details [In Page 45 - note that letter size shall be 6 mm instead of 6.5 mm].
8	PC-E-409	Non Radiation Terminal Blocks
9	RAPP-7&8/60427/2001/ES	Engg. Standard for Escutcheon plates and Hand Switches

COPYRIGHT AND CONFIDENTIAL
The information contained in this document is the property of BHARAT HEAVY ELECTRICALS LIMITED
This must not be used directly or indirectly, in any manner detrimental to the interest of the company



A4-10

**PURCHASE SPECIFICATION
LVS CONTROL PANEL
FOR PCPTF AT TARAPUR**

PS4102095

REV No. : 00

Page 6 of 20

ANNEXURE-2

Sl. No	Specification	Vendor Remarks
1	Large Video Screen in the control room shall be used for the display of important process data, mimics from the OWS, EWS or other Computer Based System. The LVS should be rugged and meant for industrial purpose and it should be able to work continuously (24 X 7) and should be of state of the art technology.	Yes/No
2	Display technology required is LED	Yes/No
3	Size available for mounting the LVS will be minimum 75" diagonal Screen size with approx. Image size to be mentioned Minimum resolution of 4K OR better Color support: 16.7 million colors OR better 16: 9 aspect ratio (min.) OR better	Yes/No Yes/No Yes/No Yes/No Yes/No
4	The brightness uniformity shall be > 85 % Minimum luminous intensity of each LVS module should be 500 cd/m2 (Typical) or brightness 2500 lumens Contrast ratio equal to better than 1500: 1 Sensors to meet the 24 X 7 application	Yes/No Yes/No Yes/No Yes/No
5	The LVS shall be capable to show the same images of OWS running on LINUX RHEL 8.0 or above and should be freely resizable and positioned on any part of the Video wall with PAN, CROP and Zoom facility with 4 Window PIP feature through high bandwidth network	Yes/No
6	LVS should display data from OWS/EWS having a keyboard & mouse and through high speed network and image hubs. The LVS management software shall be installed in OWS/EWS	Yes/No Yes/No
7	The complete system shall be interfaced on 10/100/1000 Mbps LAN as well as there should be provision of integrating RGB/component video. Minimum Full HD Video shall be made available in the control room through high bandwidth network	Yes/No Yes/No
8	The LVS should consist of the control ware like high bandwidth gateways and hubs Controller and the wall management software should be supplied from a single Manufacturer to avoid compatibility issue Wall management software as per OEM standard Availability of on-screen text based menu system as per OEM standard	Yes/No Yes/No Yes/No Yes/No
9	System should incorporate user friendly set up and maintenance tools such as universal remote control for image alignment to reduce downtime and ease in maintenance	Yes/No
10	Facility of RS-232/RS-485 port for calibration & control should be provided	Yes/No
11	Large Screen should be capable of accepting multiple inputs Graphic controller and image hub/matrix switcher to be provided As required length of compatible display cables to connect OWS/EWS/Server to matrix switcher and between Matrix switcher / controller and screen to be provided	Yes/No Yes/No Yes/No

COPYRIGHT AND CONFIDENTIAL
The information contained in this document is the property of BHARAT HEAVY ELECTRICALS LIMITED
This must not be used directly or indirectly, in any manner detrimental to the interest of the company



A4-10

PURCHASE SPECIFICATION

LVS CONTROL PANEL FOR PCPTF AT TARAPUR

PS4102095

REV No. : 00

Page 7 of 20

COPYRIGHT AND CONFIDENTIAL
The information contained in this document is the property of BHARAT HEAVY ELECTRICALS LIMITED
This must not be used directly or indirectly, in any manner detrimental to the interest of the company

12	<p>Graphic Controller/Automatic Data Processing controller Graphic controller is used for displaying windows/Linux applications directly onto the LVS. Those applications can be installed directly on to the controller, or hosted on remote workstations connected to the LAN. Display of LAN based applications shall be ensured by LVS management software. With controller, the LVS should become the default display unit of the workstations. The Controller should be based on open architecture, open source, future-proof with provision for up-gradation in an industrial 4U 19" rack mounted casing based on Intel i5/i7 with clock speed not less than 3 GHz and FSB should be higher than 800 MHz (This information is provided only for guidance). The RAM should be DDR3 SDRAM and should not be less than 4 GB, expandable up to 16 GB. The unit should be equipped with a DVD/RW Drive and minimum 6 numbers of USB2 Ports. The hard Disk should be of 2-TB SATA, 7200 RPM. The system shall work on redundant power supply of 240 V AC ($\pm 10\%$ variation), 50 Hz. In case of failure of one power supply auto switchover shall be provided.</p>	Yes/No
13	<p>Controller should fetch the data across high speed network as per proposed solution LAN connectivity is ensured for controller - It should have minimum 3 nos. 10/100/1000 Mbps Ethernet port for LAN connection Controller shall be supplied with an industrial Keyboard and mouse The compatible video output card for connecting the single LVS screen should be provided at the controller end</p>	Yes/No Yes/No Yes/No Yes/No
14	<p>Keyboards One number of keyboard on LVS panel shall be provided having inbuilt Hula-point in it, this will be used by the operator while carrying out the operations from the LVS/Operator panel. The second key-board shall be wireless and provided on OC is for doing the sitting operation from the OC by the operator. The necessary arrangement required for integration of these two keyboards with the controller/PC for LVS shall be done by the bidder.</p>	Yes/No
15	<p>Management Software The software should able to pre configure various display layouts and access them at any time with a simple mouse click. It should enable the users to see the desktop of the graphics display wall remotely on any computer connected with the Display Controller over the Ethernet and change the size and position of the various windows being shown (OEM standard features may be mentioned if the above points are not complied)</p>	Yes/No
16	Make : to be mentioned	Yes/No
17	Number of LVS : 1 No.	Yes/No
18	Display Technology : LED backlit	Yes/No
19	Mounting : On LVS Panel	Yes/No
20	Display Resolution : 4K (min.) OR better	Yes/No
21	Aspect ratio : 16 : 9 (min.) OR better	Yes/No
22	Diagonal of Screen : 75"	Yes/No
23	Weight : < 80 kg	Yes/No



A4-10

PURCHASE SPECIFICATION

LVS CONTROL PANEL FOR PCPTF AT TARAPUR

PS4102095

REV No. : 00

Page 8 of 20

COPYRIGHT AND CONFIDENTIAL
The information contained in this document is the property of BHARAT HEAVY ELECTRICALS LIMITED
This must not be used directly or indirectly, in any manner detrimental to the interest of the company

24	Screen Type : Wide View Screen	Yes/No
25	Full viewing angle : >178°	Yes/No
26	Response time of the system : ≤ 8 ms (min.) OR better	Yes/No
27	Brightness : 500 Cd/m ² OR 2500 Lumens (min.) OR better	Yes/No
28	Brightness uniformity : > 85 %	Yes/No
29	Contrast ratio : Minimum 1500 : 1 or better	Yes/No
30	Colors : 16.7 million (min.) OR better	Yes/No
31	Operating temperature : 5° C to 40° C	Yes/No
32	Operating Humidity : 10 to 90 % RH non condensing	Yes/No
33	Power Consumption : < 750 Watts	Yes/No
34	Remote Control Required	Yes/No
35	Self-Adjustment of Video Wall Required	Yes/No
36	Auto Color balancing Required	Yes/No
37	Auto Brightness Control Required	Yes/No
38	Display Control : RS-232/RS-485/IR-Remote – to be provided	Yes/No
39	Integrated Architecture Required (bidder to attach architecture)	Yes/No
40	Parallel Processing (in case if controller fails then LVS should show the outputs from CCTV / WS / Video with same operational features) – to be complied with the help of image hub/matrix switcher	Yes/No
41	Power Supply : 240 VAC @ 50 Hz (with ± 10% variation in power supply) Indian standard power cords to be supplied	Yes/No Yes/No
42	Safety Regulations : As per OEM standard certifications to be mentioned TR/TC/CoC from OEM to be provided along-with the offer	Yes/No
43	EMI/EMC requirements : As per OEM standard certifications to be mentioned TR/TC/CoC from OEM to be provided along-with the offer	Yes/No
44	IS9000, ISO14001 & ISO 18001 requirements : As per OEM standard certifications to be mentioned TR/TC/CoC from OEM to be provided along-with the offer	Yes/No
45	Software based On Screen Diagnostics : As per OEM standard Details to be mentioned	Yes/No
46	Comprehensive on-Site Warranty And spare parts warranty : As per bid terms	Yes/No

Notes on Technical requirements

1	Screen shall be flicker free and there shall not be any screen burn in due to display of same information for a long time	Yes/No
2	Hardware specifications of controller should be of latest configuration of processor, hard disk and memory (RAM) complying to minimum specs mentioned under clause 3	Yes/No
3	Supplier to confirm that quoted model is latest and will not be obsolete at the time of supply	Yes/No
4	The Control Unit should be used for projecting MMI display over a part of screen or to entire screen. Any combination of Linux / windows shall be possible. Facility for overlay shall be provided	Yes/No
5	The Large Screen Display & its accessories shall be designed in such a way that the brightness in the center of the screen and the edges of the screen is uniform and there is no perceivable difference in the quality of the picture on the center and on the edges of the screen. If any extra hardware has to be provided for achieving the above features, same shall be provided by the supplier at no extra cost	Yes/No



A4-10

PURCHASE SPECIFICATION

LVS CONTROL PANEL FOR PCPTF AT TARAPUR

PS4102095

REV No. : 00

Page 9 of 20

Site support and Service conditions

Sl. No.	Details	Vendor Confirmation
1	Warranty : As per bid terms	Yes/No
2	Packaging: 1. Weatherproof packing with sufficient cushioning to avoid transit damage, Secured Packing of the system [No loose items / tied with a string]. 2. Vendor to provide a detailed packing list of the items packaged in each section and there should be a direct correlation of the items in packing list to the items mentioned in the main Bill of Material. This is for the purpose of verifying that all the line items mentioned in the BOM are supplied during dispatch from Vendor works and while receiving the items at site	Yes/No
3	Storage requirement at site should be specified	Yes/No
4	Any mechanical damaged part should be replaced at site free of cost	Yes/No
5	The screen offered should not bend due to transport, storage, ambient temperature etc. during or after installation. In case bend is observed in screen during or after Installation, the same shall be replaced by Supplier at free of cost	Yes/No
6	All services required for Assembly, Installation & commissioning of Large screen shall be provided at site	Yes/No
7	All requirements of installation & specific material required shall be provided by supplier, as required by control room designer	Yes/No
8	Vendor to mention the agency for maintenance support in India with complete contact details	Yes/No

Documents to be given along with Technical Proposal

Sl. No.	Details	Vendor Confirmation
1	Bill of Material [List of items, part no, make and quantity]	Yes/No
2	Technical Write – up with configuration diagram showing workstation and LAN, with explanation, how the offer system will meet our requirement	Yes/No
3	Data Sheet of Models Proposed	Yes/No
4	Deviations, if any, with respect to the specifications and technical justification of alternate offer.	Yes/No
5	Point – wise compliance against each clause given in this specification	Yes/No
6	Complete details of Display Controller Unit with its associated software	Yes/No
7	Layout arrangement drawings	Yes/No
8	Dimensional details of Large screen unit	Yes/No
9	Recommendation on light, color of room, ergonomic arrangement with respect to operator desk and control room.	Yes/No
10	List of Service Centers in India.	Yes/No

COPYRIGHT AND CONFIDENTIAL
 The information contained in this document is the property of BHARAT HEAVY ELECTRICALS LIMITED
 This must not be used directly or indirectly, in any manner detrimental to the interest of the company



A4-10

PURCHASE SPECIFICATION
LVS CONTROL PANEL
FOR PCPTF AT TARAPUR

PS4102095

REV No. : 00

Page 10 of 20

Documents to be submitted for approval [Manufacturing Clearance] after placement of order

Sl. No.	Details	Vendor Confirmation
1	Configuration Diagram	Yes/No
2	Dimensional drawings (including cutout details for Large Screen display unit)	Yes/No
3	OGA & Layout drawings of Display unit	Yes/No
4	Quality Plan	Yes/No
5	Test Protocol, Test Instruction, and Test Reports	Yes/No
6	Datasheet of Models being supplied	Yes/No
7	Any other relevant documents	Yes/No

Documents to be given along with equipment

Sl. No.	Details	Vendor Confirmation
1	Manual of the individual equipment involved in making the total system as well as the documents for the total system to be supplied	Yes/No
2	Installation and commissioning Instruction manuals	Yes/No
3	Licensed Software and drivers along with original media	Yes/No
4	List of Equipment	Yes/No
5	List of service centers close to location with contact person name, phone and address	Yes/No
6	Test Certificates, should include following among others, wherever applicable 1 Visual Inspection Report. 2 GA, BOM, LAYOUT. 3 Dimensions. 4. Alignment Details. 5 Component Rating / Make / Type. 6 Wiring details.	Yes/No

Acceptance Criteria

- 1.Completeness of supplies and documentation as per specification.
- 2 Test certificates.

Training

Sl. No.	Details	Vendor Confirmation
1	Training shall be provided in operation & maintenance of equipment to BHEL and Customer personnel during and after commissioning at site.	Yes/No

COPYRIGHT AND CONFIDENTIAL
 The information contained in this document is the property of BHARAT HEAVY ELECTRICALS LIMITED
 This must not be used directly or indirectly, in any manner detrimental to the interest of the company



A4-10

PURCHASE SPECIFICATION LVS CONTROL PANEL FOR PCPTF AT TARAPUR

PS4102095

REV No. : 00

Page 11 of 20

COPYRIGHT AND CONFIDENTIAL
The information contained in this document is the property of BHARAT HEAVY ELECTRICALS LIMITED
This must not be used directly or indirectly, in any manner detrimental to the interest of the company

Configuration Drawing

Note: The typical connectivity scheme designed for NPCIL PCPTF – Tarapur project is attached below – This design is made in line with the requirement finalized with NPCIL

Note: The display output from OWS/EWS is mini DP and from server is DP as per the latest availability
Compatible convertors / adapters should be provided to ensure the connectivity as indicated in the scheme above

DP – Display Port, mini DP – mini Display Port

Video cable length from OWS/Server to Image hub –approx. 15-20m length

TYPICAL LVS CONNECTIVITY SCHEME FOR TARAPUR

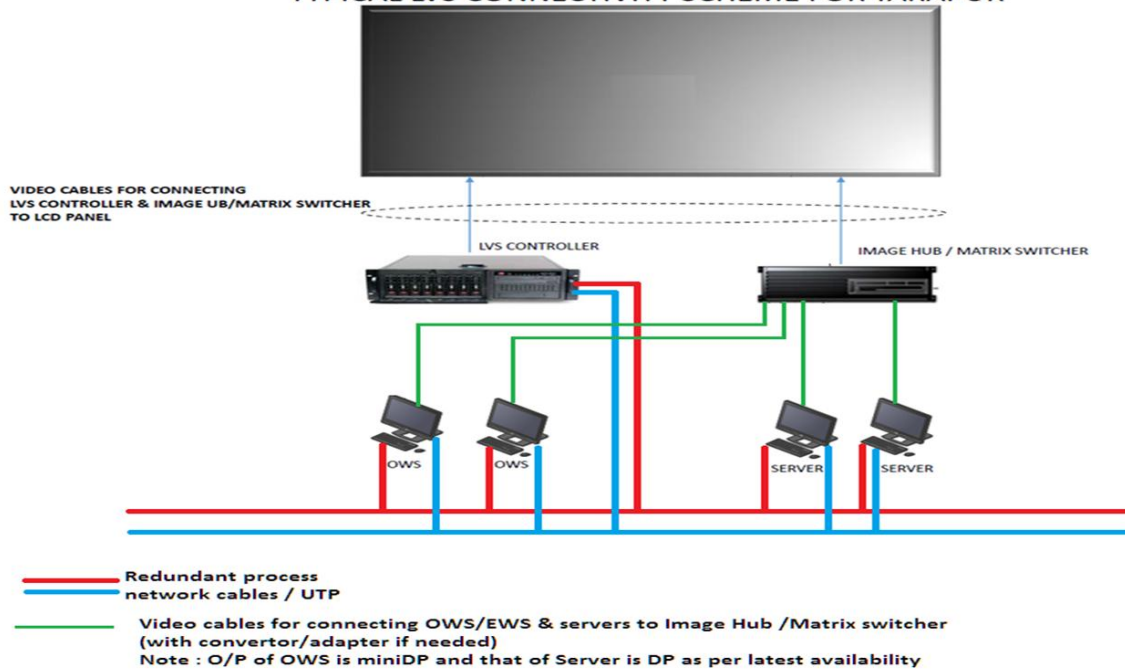

ANNEXURE-3: SAMPLE FUNCTIONAL TEST TO BE CARRIED OUT

THE TEST SETUP WILL BE MADE WITH INTEGRATION OF LVS SCREEN, CONTROLLER, IMAGE HUB / MATRIX SWITCHER AND SAMPLE WORKSTATIONS AS PER THE CONNECTIVITY SCHEME AT THE VENDOR PREMISES AND WILL BE WITNESSED BY NPCIL

DETAILS OF PROJECT

PROJECT NAME:

CUSTOMER ORDER NO:

PLACE OF FAT:

SYSTEM SUMMARY

LVS MAKE AND MODEL NO:

CONTROLLER MAKE AND MODEL NO:

IMAGE HB / MATRIX SWITCHER MAKE AND MODEL NO:

CABLES AND CONNECTORS USED: QUANTITY AND TYPE DETAILS:

BILL OF MATERIAL VERIFICATION:

BOM FOR THE PROJECT TO BE MENTIONED HERE WITH DETAILS

TESTS TO BE CARRIED OUT

LVS Functional test:

DESCRIPTION	REMARKS
Configuration of 1 LVS screen installed properly with controller	
Screen size verification : 75"	
Aspect ratio verification : 16:9 or better	
Check panel without flickering	
Check for antiglare property	
Check for plug and play function	
Check power supply : AC 240V +- 10% ,50 Hz	
Check remote function	
Check the input connectors : VGA/DVI/HDMI/DP (whichever applicable)	

LVS controller test:

DESCRIPTION	REMARKS
Controller should power up without any human intervention after pressing the power button	
Controller desktop must appear after boot sequence	
Controller should support applications supported by Windows 10 operating system / RHEL 8.0 operating system	
Check redundant hot-swappable power supply	
Check control by client	
Check output resolution	
Check layout creation	
Check layout launch	
Check the important features of LVS wall management software	

Image hub/Matrix switcher test:

DESCRIPTION	REMARKS
Controller should power up with power button	
Check for power supply	
Check control by client	
Check output resolution	

Cabling:

DESCRIPTION	REMARKS
As per connectivity scheme	
Ensure adapters / convertors used for completion of system	
Check for sufficient length of cabling for the site condition	

**ANNEXURE-4: SAMPLE QUALITY PLAN FOR LVS SYSTEM
NUCLEAR POWER CORPORATION OF INDIA LIMITED**

QUALITY ASSURANCE PLAN			QAP NO: PCPTF/60000/0526/QAP	
ITEM: LVS SYSTEM			REV NO: 00	DATE:
PROJECT: PCP TEST FACILITY AT TARAPUR (PCPTF)		NAME OF PACKAGE: LVS SYSTEM		PAGE NO : 1 OF 5
		PO NO : CMM/EIC/00-66-3-3400/ePO/38824 DATED 17/03/2020		
NAME OF PACKAGE CONTRACTOR AND ADDRESS				
 M/S BHARAT HEAVY ELECTRICALS LIMITED-ELECTRONICS DIVISION PB NO 2606 MYSORE ROAD BANGALORE-PIN-560026 KARNATAKA, INDIA				
BHEL QAP No	ITEM NO.	BRIEF DESCRIPTION		DESIGN CODE/ SPEC NO.
	1. 2. 3.	LVS SYSTEM: MAKE AND MODEL TO BE MENTIONED LVS CONTROLLER: MAKE AND MODEL TO BE MENTIONED IMAGE HUB / MATRIX SWITCHER: MAKE AND MODEL TO BE MENTIONED		
FOR BHARAT HEAVY ELECTRICALS LIMITED (STAMP & SIGNATURE WITH DATE FOR REVIEWED BY & APPROVED BY)			FOR NPCIL (STAMP & SIGNATURE WITH DATE FOR CHECKED BY REVIEWED BY & APPROVED BY)	
	NAME & DESIGNATION	SIGNATURE	NAME & DESIGNATION	SIGNATURE
CHECKED BY				
REVIEWED BY				
APPROVED BY				

QUALITY ASSURANCE PLAN

CLIENT	NUCLEAR POWER CORPORATION OF INDIA LIMITED	PROJECT :	PCP TEST FACILITY AT TARAPUR (PCPTF)																			
CONTRACTOR	BHEL-ELECTRONICS DIVISION	PO No. :	CMM/EIC/00-66-3-3460/ePO38824, Dated 17/03/2020																			
VENDOR		BHEL QAP No.																				
		BHEL EDMS. No.																				
QAP FOR	LVS SYSTEM FOR PCP TEST FACILITY AT TARAPUR (PCPTF)	NPCIL DOC. No.	P	C	P	T	F	/	6	0	0	0	0	/	0	5	2	6	/	Q	A	P
		REV NO	00			DATE							Page 2 of 5									

Scope and Purpose:

This document indicates the requirements expected from the EPC contractor/manufacturer of the equipment's. Subsequent to the placement of purchase order contractor/manufacturer shall submit for purchaser's approval, a quality assurance plan in line with this document incorporating specific document numbers for "format of records", "acceptance norms" and "reference documents".

Abbreviations:

P:	Perform.	W:	Witness	V:	Verification of records.		
1:	NPCIL	2:	EPC Contractor	3	Prime Supplier / Manufacturer.	4:	NPCIL approved Test Laboratory.
TC:	Test Certificate.	TR:	Test Report.	AD:	NPCIL Approved Document such as Tender Document, Purchase order, Datasheets, Drawings & Test procedures.		
IS:	Indian Standards	IEC:	International Electro technical commission standards	IEEE:	Institute of Electronics and Electrical Engineers standards		
CHP:	Customer Hold Point (Customer is NPCIL)						
Critical : (C)	The characteristic of a component, Process or Operation failure of which will surely cause operating failure of intermittent troubles which is difficult to rectify at site or render the unit unfit for use or cause safety hazards.						
Major : (B)	The characteristic of a component, Process or Operation whose failure may cause operation failure which cannot be readily corrected at site or cause substandard performance. Increased in erection and maintenance cost, reduced life or seriously affect the aesthetics.						
Minor : (A)	The characteristics of a component. Process or Operation whose failure neither materially reduce the usability of the product in operation nor does it affect the aesthetics aspects.						
Sampling Plan :	Wherever quantum of check is indicated as sampling, it should be done generally in accordance with double sampling plan of IS:2500. Part-1, AQL: 1% normal level of inspection. If 100% witness of test is carried out by prime supplier, purchaser may witness on sample basis or if 100% "witness" of test is carried out by "sub-vendor", 'prime supplier' may witness on sample basis. Any deviation to this has to be specifically mentioned in the remarks column of QAP.						

QUALITY ASSURANCE PLAN

CLIENT	NUCLEAR POWER CORPORATION OF INDIA LIMITED	PROJECT :	PCP TEST FACILITY AT TARAPUR (PCPTF)																			
CONTRACTOR	BHEL-ELECTRONICS DIVISION	PO No. :	CMM/EIC/00-66-3-3460/ePO38824, Dated 17/03/2020																			
VENDOR		BHEL QAP No.																				
		BHEL EDMS. No.																				
QAP FOR	LVS SYSTEM FOR PCP TEST FACILITY AT TARAPUR (PCPTF)	NPCIL DOC. No.	P	C	P	T	F	/	6	0	0	0	0	/	0	5	2	6	/	Q	A	P
		REV NO	00			DATE			Page 3 of 5													

Sl. No	COMPONENT & OPERATION	CHARACTERISTICS	CATEGORY	METHOD OF CHECK	EXTENT OF CHECK			REFERENCE DOCUMENT	ACCEPTANCE NORMS/VALUE	FORMAT OF REPORT	AGENCY			REMARKS
					3	2	1				P	W	V	
1.0	Materials :													
1.1	LARGE VIDEO DISPLAY LVS-70 (Customized)	Functional, Physical & Visual Check	Major	Verification	100%	100%	100%	To be decided after PO	To be decided after PO	TEST REPORTS	3	2	2	
		Type Test	Major	Climatic and EMI/EMC	1 Nos.	1No	1No	To be decided after PO	To be decided after PO	ETR/TC	3	2	2	
1.2	LVS DISPLAY CONTROLLER	Functional, Physical & Visual Check	Major	Verification	100%	100%	100%	To be decided after PO	To be decided after PO	TEST REPORTS	3	2	2	
		Type Test	Major	Climatic and EMI/EMC	1 Nos.	1No	1No	To be decided after PO	To be decided after PO	ETR/TC	3	2	2	

QUALITY ASSURANCE PLAN

CLIENT	NUCLEAR POWER CORPORATION OF INDIA LIMITED	PROJECT :	PCP TEST FACILITY AT TARAPUR (PCPTF)																			
CONTRACTOR	BHEL-ELECTRONICS DIVISION	PO No. :	CMM/EIC/00-66-3-3460/ePO38824, Dated 17/03/2020																			
VENDOR		BHEL QAP No.																				
		BHEL EDMS. No.																				
QAP FOR	LVS SYSTEM FOR PCP TEST FACILITY AT TARAPUR (PCPTF)	NPCIL DOC. No.	P	C	P	T	F	/	6	0	0	0	0	/	0	5	2	6	/	Q	A	P
		REV NO	00			DATE			Page 4 of 5													

Sl. No	COMPONENT & OPERATION	CHARACTERISTICS	CATEGORY	METHOD OF CHECK	EXTENT OF CHECK			REFERENCE DOCUMENT	ACCEPTANCE NORMS/VALUE	FORMAT OF REPORT	AGENCY			REMARKS
					3	2	1				P	W	V	
1.3	IMAGE HUB / MATRIX SWITCHER	Functional, Physical & Visual Check	Major	Verification	100%	100%	100%	To be decided after PO	To be decided after PO	TEST REPORTS	3	2	2	
		Type Test	Major	Climatic and EMI/EMC	1 Nos.	1No	1No	To be decided after PO	To be decided after PO	ETR/TC	3	2	2	
1.4	CABLES Write Type of cables	Physical & Visual Check	Major	Verification	100%	100%	100%	To be decided after PO	To be decided after PO	TEST REPORTS/TC	3	2	2	
1.5	CONVERTORS / ADAPTERS / SPLITTERS (AS APPLICABLE)	Functional Physical & Visual Check	Major	Verification	100%	100%	100%	To be decided after PO	To be decided after PO	TEST REPORTS	3	2	2	

QUALITY ASSURANCE PLAN

CLIENT	NUCLEAR POWER CORPORATION OF INDIA LIMITED	PROJECT :	PCP TEST FACILITY AT TARAPUR (PCPTF)																			
CONTRACTOR	BHEL-ELECTRONICS DIVISION	PO No. :	CMM/EIC/00-66-3-3460/ePO38824, Dated 17/03/2020																			
VENDOR		BHEL QAP No.																				
		BHEL EDMS. No.																				
QAP FOR	LVS SYSTEM FOR PCP TEST FACILITY AT TARAPUR (PCPTF)	NPCIL DOC. No.	P	C	P	T	F	/	6	0	0	0	0	/	0	5	2	6	/	Q	A	P
		REV NO	00			DATE			Page 5 of 5													

Sl. No	COMPONENT & OPERATION	CHARACTERISTICS	CATEGORY	METHOD OF CHECK	EXTENT OF CHECK			REFERENCE DOCUMENT	ACCEPTANCE NORMS/VALUE	FORMAT OF REPORT	AGENCY			REMARKS
					3	2	1				P	W	V	
1.6	CONNECTION CHECK	Visual Check	Major	Verification	100%	100%	100%	To be decided after PO	To be decided after PO	TEST REPORTS	3	2	2	
1.7	IR REMOTE OPERATION	Visual Check	Major	Verification	100%	100%	100%	To be decided after PO	To be decided after PO	TEST REPORTS	3	2	2	
1.8	PC DISPLAY SWITCHING	Visual Check	Major	Verification	100%	100%	100%	To be decided after PO	To be decided after PO	TEST REPORTS	3	2	2	
1.9	INTEGRATED TESTING OF LVS AND CONTROLLER AS PER THE APPROVED SCHEME	Visual Check	Major	Verification	100%	100%	100%	To be decided after PO	To be decided after PO	TEST REPORTS	3	2	2	



A4-10

PURCHASE SPECIFICATION**LVS CONTROL PANEL
FOR PCPTF AT TARAPUR**

PS4102095

REV No. : 00

Page 20 of 20

ANNEXURE-5**Spares list to be supplied as loose items**

Sl. No	Item	Quantity
1	Alarm Annunciator window with Front cover Replacable Facia. Voltage: 24V DC. Annunciator Window Size: 48x48mm.	4
2	HAND SWITCH 4POLE, 2 Position; Size - 48(W) x 48(H) mm	2
3	Emergency push button 2 NO + 2 NC contacts; Size - 48(W)x24(H) mm Colour -Red; Shape - Round	2
4	2PB+2LED Module; Size - 48(W)x24(H) mm; PB COLOUR: Left-RED, Right - GREEN; LED COLOUR: Left-GREEN, Right - RED.	2
5	Recessed PB module. Size - 48(W)x24(H) mm; Shape - Square, Colour - Black	1
6	Relay 1 NO + 1 NC; Coil supply: 24 V DC, Contact Rating: 220 V DC	2
7	Terminal Block; Screw-connection type; Suitable for 0.5 to 4 sq. mm. wires; Colour:Grey;	90
8	MCB, 16 A, 230 V AC, Double pole	1
9	MCB, 3 A, 230 V AC, Double pole	1
10	MCB, 2 A, 230 V AC, Double pole	1
11	Blank tiles 24 mm x 48 mm	50
12	Blank tiles 24 mm x 24 mm	50

Note: Make & model of the above mentioned items shall be same as that of the items mounted in the panel.

COPYRIGHT AND CONFIDENTIAL

The information contained in this document is the property of BHARAT HEAVY ELECTRICALS LIMITED
This must not be used directly or indirectly, in any manner detrimental to the interest of the company

TITLE
PURCHASE SPECIFICATION
LVS CONTROL PANEL
FOR PCPTF AT TARAPUR

Dept Code
410

DRN.

NAME

SIGN

DATE

PREPARED

SURESH B /
SISIR BALAGOPAL

16.05.2022

CHECKED

JANAK KUMAR /
BIRENDER NATH
SHARMA

16.05.2022

APPROVED

MALA SIBOO /
PRAKASH D

-sd-

16.05.2022

**NUCLEAR POWER CORPORATION OF INDIA LTD.,
(A GOVT. OF INDIA ENTERPRISE)**

SPECIFICATION NO. PC-E- 314, REV-2

TECHNICAL SPECIFICATION

ON

**MAIN CONTROL ROOM PANELS
FOR 700MWe ATOMIC POWER PROJECTS**

REF. USI NO: 66100

REVISION NO:

DATE OF ISSUE

TOTAL NO. OF PAGES
(INCLUDING COVER
SHEET)

0	1	2		
June 2010	December 2010	April 2011		
38	42	39		

**PREPARED BY: VIRENDRAKUMAR
WANKHEDE, EE (SCI) (sd/-) 01-06-2010**

T.JAYALAKSHMI, DCE (SCI) (sd/-) 01-06-2010

CHECKED BY: C.P. SHRIVASTWA, ACE (SCI) (sd/-) 02-06-2010

REVIEWED BY: A.V.UGHADE, ACE (SCI) (sd/-) 07-06-2010

APPROVED BY: V.K.MINHAS, ACE (SCI) (sd/-) 07-06-2010
(Name & Designation) (Signature) (Date)

(FOR REVISION SEE REVISION CONTROL SHEET)

REVISION CONTROL SHEET

DOCUMENT TYPE : TECHNICAL SPECIFICATION

DOCUMENT NO : PC-E- 314, REV-2

**TITLE : TECHNICAL SPECIFICATION ON
MAIN CONTROL ROOM PANELS FOR
700MWe ATOMIC POWER PROJECTS**

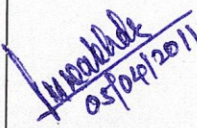
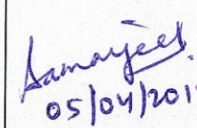
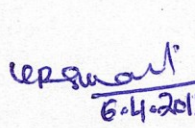
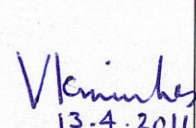
REV. NO. & DATE	DESCRIPTION OF REVISION	REVISED BY NAME & SIGNATURE	CHECKED BY NAME & SIGNATURE	REVIEWED BY NAME & SIGNATURE	APPROVED BY NAME & SIGNATURE
Rev. 1 Dec 2010	Details of the various items mounted on the MCR & BCR panels.	(Sd/-) (03-12-2010) Virendrakumar Wankhede EE(SCI)	(Sd/-) (15-12-2010) C.P. Shrivastwa ACE(SCI)	(Sd/-) (21-12-2010) A.V.Ughade ACE (RP & CI)	(Sd/-) (23-12-2010) V.K.Minhas ACE(SCI)
Rev. 2 April 2011	Revised for making the specification uniform and to match with other specifications	 05/04/2011 Virendrakumar Wankhede EE(SCI)	 05/04/2011 S.S.Kalsi Dy.CE (SC)	 6-4-2011 C.P. Shrivastwa ACE(SCI)	 13-4-2011 V.K.Minhas ACE(SCI)

NPCIL PROPRIETARY

This document is the property of Nuclear Power Corporation of India Limited (NPCIL). No exploitation or transfer of any information contained herein is permitted in the absence of an agreement with NPCIL, and neither the document nor any such information may be released without the written consent of NPCIL.

1.0 SCOPE

This specification covers design, manufacture, inspection, testing at works, packing, complete documentations, safe transportation and delivery at site, erection, commissioning, guarantee and handing over of Main Control Room (MCR) panels and Back-up Control Room Panel (BCRP) with mosaic control tiles for two units of 700MWe PHWRs. The following jobs to be carried out;

- a) Preparation of structural details drawing, mechanical design and fabrication of the panels.
- b) Preparation of drawings like General Arrangement (GA), Bill of Materials (BM) & Name Plate details (DD) etc.
- c) Procurement, mounting & wiring of mosaic control tiles on the panels.
- d) Procurement, mounting & wiring of electrical Instruments, such as recorders, indicating meters, hand-controllers, timers etc. on MCR/BCR panels.
- e) Installation, alignment and welding with the EPs provided for these panels.
- f) Mounting and wiring of free supply instruments on MCR/BCR panels such as, monitors, Tap position indicators etc at site during commissioning.
- g) Inspection and test all in accordance with purchaser's requirement mentioned in this specification.
- h) Supply of 10 % of all components including mosaic control tiles, blank tiles etc. as spares.
- i) Carry out modification in the panels matching with final design drawings (frozen drawings) at site. Work shall be carried out: addition/deletion of components, wiring addition/deletion with feruling, addition/deletion of name plates/escutcheon plates etc.

2.0 CONTENTS

The requirements of this specification are presented under the following section headings:

<u>Description</u>	<u>Section</u>
• Applicable Standards, Specifications and Drawings	3
• Material and Workmanship	4
• General Function and Description	5
• Requirements	6
• Inspection, Tests and Reports	7
• Tests	8
• Packaging and Shipment	9
• Information required to be furnished with the bid	10
• Delivery Schedule and Technical data to be furnished by the suppliers	Annexure – A
• Sample Quality Assurance Plan for MCR Panel	Annexure – B

3.0 APPLICABLE STANDARDS, SPECIFICATIONS AND DRAWINGS

All documents listed below constitute a part of this specification. In the event that drawings or data listed below conflict with the requirements of this specification, the requirements of this specification shall govern.

3.1 Applicable Standards

- | | | | |
|--------|-----------------------|---|---|
| 3.1.1 | IS/IEC-60947 (Part-1) | - | Specification for low voltage switchgear & control gear (Appendix-C Degree of protection & enclosed equipment). |
| 3.1.2 | IEEE-344 | - | Recommended practices for seismic qualification of Class-1E equipment for Nuclear Power Generating Station |
| 3.1.3 | IEEE-420 | - | Standard for the design and qualification of Class 1E Control Boards Panels and Racks used in Nuclear Power Generating Stations |
| 3.1.4 | BS-89 | - | Direct acting indicating analog electrical measuring instruments & their accessories |
| 3.1.5 | JSS-51208 | - | Detail specification for switches |
| 3.1.6 | IS -1248 | - | Direct acting indicating analog electrical measuring instruments & their accessories |
| 3.1.7 | IS-101 | - | Methods of sampling & test for paints, varnishes & related products |
| 3.1.8 | IS-228 | - | Methods of chemical analysis of steel |
| 3.1.9 | IS-513 | - | Cold rolled low carbon steel sheets and strips |
| 3.1.10 | IS-3618 | - | Phosphate treatment of iron & steel for protection against corrosion |
| 3.1.11 | IS-6005 | - | Code of practice for phosphating of iron & steel |
| 3.1.12 | IS-2062 | - | Steel for general structure purposes. |

- 3.1.13 IS-1572 - Specification for electroplated coatings of cadmium on Iron and Steel (for non-threaded parts). Grading of service condition – severe
- 3.1.14 IS-3655 - Recommended practices for electroplating
- 3.1.15 BS-3382 - Electroplated coating on threaded components Part-I- Cadmium on Steel Components.
- 3.1.16 ASME B & PV, - Rules for construction of nuclear facility and components.
Sec-III : Sub-section-NF

3.2 Applicable Specifications

- 3.2.1 PP-E-123 - Common Abbreviations used on control panel
- 3.2.2 PC-E-317 - Paperless Recorder.
- 3.2.3 PC-E-409 - Non Radiation Resistant Terminal Blocks.
- 3.2.4 PC-E-316 - Indicating Meters
- 3.2.5 PP-E-1209 - Liquid penetrant test for welds.
(This will be given only to successful bidder).
- 3.2.6 PC-E-451 - Hand Controllers
- 3.2.7 Project/63480/2011/ISS- Timer Module
- 3.2.8 PC-E-452 - Controllers
- 3.2.9 PC-E-45 - Temperature transmitter with built-in display
- 3.2.10 PC-E-298 - Instantaneous Relays
- 3.2.11 PC-E-319 - Main Annunciator System
- 3.2.12 PC-E-2061 - Technical Specification for requirements of components for Instrumentation Items
- 3.2.12 Project/60427/2001/ES- Engg Standard for Hand-switch
- 3.2.14 Project/60428/2001/ES- Engg standard for HS & PB color code
- 3.2.15 PC-E-709 - Engg Standard for Instrumentation and control system Grounding

As it is anticipated that control equipment of this nature includes equipment already developed by the contractor, the standards to which such equipment is manufactured shall be stated by the contractor while tendering.

3.3 Applicable Drawings

3.3.1 Floor response spectra for the Control Building (CB) - 111M and Reactor Auxiliary Building (RAB) - 109M elevation for the Safe Shutdown Earthquake will be furnished later.

3.3.2 A list of applicable drawings of individual panels and other reference elementary drawings with their issue/expected issue dates will be supplied in the Information Transmittal Form and will be issued panelwise. It is contractor's responsibility to work out the complete design and prepare detail drawings. The following drawings are also applicable.

- | | | | |
|-----|-----------------------|---|--|
| 1) | Project/66000/2001/GA | : | Main control center layout
(CB- 111M FL EL) |
| 2) | Project/66900/2009/GA | : | Back-up control center layout
(RAB- 109M FL EL) |
| 3) | Project/66100/2001/GA | : | Arrangement & details of Main Control
Room Panels (MCRP) |
| 4) | Project/66100/2002/GA | : | Standard Panel Layout |
| 5) | Project/66100/2003/GA | : | MCRP-1 Reactor Regulation and protection
systems vertical & sloping panel equipment
layout |
| 6) | Project/66100/2003/BM | : | MCRP-1 Bill of material |
| 7) | Project/66100/2005/GA | : | MCRP-2 Decay heat removal systems
vertical & sloping panel equipment layout |
| 8) | Project/66100/2005/BM | : | MCRP-2 Bill of material |
| 9) | Project/66100/2007/GA | : | MCRP-3 ECCS & Containment Isolation
system vertical & sloping panel equipment
layout |
| 10) | Project/66100/2007/BM | : | MCRP -3 Bill of material |
| 11) | Project/66100/2009/GA | : | MCRP-4 Personal Safety and Equipment
Safety systems vertical & sloping panel
equipment layout |
| 12) | Project/66100/2009/BM | : | MCRP-4 Bill of material |
| 13) | Project/66100/2011/GA | : | MCRP-5 400KV/220KV, 22KV, 6.6KV
Class-IV Electrical system vertical & sloping
panel equipment layout |
| 14) | Project/66100/2011/BM | : | MCRP-5 Bill of material |

- | | | | |
|-----|-----------------------|---|---|
| 15) | Project/66100/2013/GA | : | MCRP-6 415V CL-IV, 6.6KV&415KV CL-III, 415 CL-II DIV-I vertical & sloping panel equipment layout |
| 16) | Project/66100/2013/BM | : | MCRP-6 Bill of material |
| 17) | Project/66100/2015/GA | : | MCRP-7 415V CL-IV, 6.6KV&415KV CL-III, 415 CL-II DIV-II vertical & sloping panel equipment layout |
| 18) | Project/66100/2015/BM | : | MCRP-7 Bill of material |
| 19) | Project/66100/2017/GA | : | MCRP Large Video Screen vertical & sloping panel equipment layout |
| 20) | Project/66100/2017/BM | : | MCRP-LVS Bill of material |
| 21) | Project/66900/2002/GA | : | Back-up control room panel (BCRP) vertical & sloping panel equipment layout |
| 22) | Project/66900/2002/BM | : | BCRP 6690-PL-1 Bill of material |
| 23) | Project/60427/2001/ES | : | Engineering standard for Escutcheon plates and hand-switches for KAPP-3&4 |
| 24) | Project/60483/2001/ES | : | Engineering standard for color codes of indicating lamps for KAPP-3&4 |
| 25) | Project/60428/2001/ES | : | Engineering standard for color codes for Hand-switches and push-buttons for KAPP-3&4 |

4. MATERIALS AND WORKMANSHIP

4.1 Materials, Process and Parts

Materials, process and standard parts which are not specifically designated herein and which are necessary to meet this specification shall be of first class commercial quality and in accordance with good practice pertinent to the manufacture of industrial instrument control panels.

4.2 Environment for the manufacture

4.2.1 Clean Area for Manufacture

The panel shall be protected at all stages of manufacture from dust, dirt and fumes, which might result in causing damage to the finished jobs. If forced ventilation is provided filtered air shall be used. Care shall be taken to ensure proper handling of jobs to avoid any mechanical damages like dents, indentations, bending etc., which might be difficult to correct.

The standard of cleanliness maintained in areas like paint shop & assembly shop should ensure the quality of job which would have resulted if done in a separate room with painted walls and vinyl tiled floors and which are vacuum cleaned atleast once in a day.

4.2.2 Cleanliness and Housekeeping during Manufacture

Before assembly of components commences panels shall be thoroughly cleaned and wiped down to remove any loose particles remaining after steel fabrication and painting.

During assembling, at least once in each working day the working space and the equipment shall be cleaned. A vacuum cleaner shall necessarily be used if cutting or similar operations are carried out during this stage.

The equipment shall be thoroughly cleaned with blower and vacuum cleaned at the completion of manufacture and testing and then fully covered immediately with plastic sheets.

In case, when certain mechanical operations during electrical assembly produce swarf, dust or other deleterious by-products all care shall be taken to avoid these getting into the equipment. For example, plastic sheets shall be taped in behind any point where new holes are cut / drilled on a panel.

5.0 General Functions and Description:

5.1 General Function

MCR/BCR panels act as interface between human and machine. These panels are most important equipments for effective and safe operation of Nuclear Power Plants.

The Functions of MCR/BCR Panels is to provide the operator with accurate, complete and timely information regarding the status of plant equipment and systems for all operational states including accident conditions.

5.2 Description

Control, indications and displays which require immediate attention of the operator are provided on MCR/BCR Panels. These are designed for standing operation. The panel consists of vertical and sloping panel for convenience of the operator.

Mosaic grid shall be used on sloping portion and vertical portion of the MCR/BCR Panels. Annunciator area of vertical portion of the panel shall also be of mosaic control tiles based.

6.0 REQUIREMENTS

6.1 General

Environment and Operating Conditions

Normal Operating Conditions

Ambient temperature from 8 °C to 45 °C and relative humidity up to 90 %

Storage Conditions

Ambient temperature from 5 °C to 55 °C and relative humidity up to 95 %

6.1.1 List of Panels

The control room panels are divided into 13 separate assemblies as listed below for one unit. Identical 13 numbers of panels are required for other unit. The arrangement of these panels within the Control Room is shown in drawings Project/66000/2001/GA and Project/66900/2001/GA.

<u>Panel No.</u>	<u>Functional Description</u>
6610-PL-1	Reactor Regulation & Protection System
6610-PL-2	Decay Heat Removal System
6610-PL-3	ECCS & Containment Isolation System
6610-PL-4	Equipment & Personnel Safety System
6610-PL-5	400KV/220KV, 21KV, 6.6KV Electrical System
6610-PL-6	6.6KV and 415V CL-III, 415V CL-II DIV-I Electrical System
6610-PL-7	6.6KV and 415V CL-III, 415V CL-II DIV-II Electrical System
6610-LVS-PL-1	} Large Video Screen panels
6610-LVS-PL-2	
6610-LVS-PL-3	
6610-LVS-PL-4	
6610-LVS-PL-5	
6690-PL-1	Back-up control room panel

6.1.2 Contractor's Supply

The Contractors supply as a minimum shall include the following:

- a) Fully self-supporting fabricated steel panel assemblies as called for 6.1.1 above
- b) Necessary gland plates for cable entry in the panel
- c) All name-plates/tagging tiles as required by the purchaser
- d) Hand rails for protection of equipment at the sloping portion of the panel as per clause 6.6.2 of this specification

- e) Mounting and wiring of LED lamp and cooling fans as per clause no.6.7.5.4 and 6.7.5.5
- f) Control Power supply sockets of 240 VAC two at the front and two at the rear of each panel as mentioned in section 6.7.5.3 of this specification
- g) Electrical Grounding clamps/bus bars as per clause 6.7.4 of this specification
- h) Procurement of all instruments/components and mounting and wiring of the same. Instruments/Components selected for use on control panels shall be as per national/international/defence standards and shall also meet seismic requirements given in section 6.5 of this specification. A list of process indicating meters, Ammeters, Voltmeters, Wattmeters, VAR meters, frequency meters, synchroscope, P.F. meters, hand switches, push buttons etc. specifying their type, ratings, scale range etc. are given in Bill of Material (BMs) of the panels
- i) Large video screen panels 6610-LVS-PL-1 to 5 listed above in clause number 6.1.1 will have cutouts on vertical portion for mounting of Large Video Screens (LVS). Panel structure identical to 1700 mm width panel shall be made having sloping panel and window annunciator portion as shown in the drawing no. Project/66100/2017/GA.

The components/Instruments to be procured by contractors includes the following

Mosaic Control Tiles and the following instruments/components suitable for mounting on mosaic grid structure.

- Synchroscope
- Rotary hand switches
- Push button switches
- LED Lamp assemblies
- Discrepancy switches.
- Semaphore indicators
- Indicating meters
- Paperless Recorders
- Annunciator windows

6.2 Specification of instruments to be procured by contractor is as follows:

6.2.1 Control Tiles

Mosaic Grid

The mosaic grid of uniform dimensions of 24 mm x 24 mm shall be supplied. The grid shall be metallic & shall provide support framework for mounting the various components such as control tiles, indicators, recorders, controllers, VDU etc.

The mosaic grid shall permit side by side mounting of instruments without any

gap between the bezels of the instruments.

It shall be possible to install the instruments with dimensions deviating from those specified in DIN standards.

It shall be possible to cut the grid at any point to provide space for mounting bigger instruments of DIN or non DIN dimensions without any significant reduction to the overall structural integrity.

It shall be possible to modify or interchange the control tiles locations without affecting the grid.

Mosaic Control tiles

The Mosaic control tiles shall be used for controls & indications and shall be fitted on Mosaic grid framework. Various types of control tiles include the following and details of them are given in the specification.

- a) Pushbutton module with LED indications (max. 3 PBs & 5 LED indications)
- b) Rotary switch
- c) Key operated switch
- d) Discrepancy switch
- e) Release pushbutton
- f) Emergency off pushbutton
- g) Selector switch
- h) Status indication
- i) Mimic diagrams
- j) Indicator
- k) Tagging tile
- l) Blank tile
- m) Annunciator Windows

The material of Mosaic control tiles shall have the following properties:

- High mechanical strength
- High temperature resistance upto 130⁰C
- High dimensional stability
- High color stability
- Ultra violet resistant
- Non reflecting
- Non Hygroscopic
- Flame retardant
- Antistatic
- Termite proof

- Shall not produce corrosive gases while burning
- Antitoxic
- Suitable for filing & drilling

The Mosaic control tiles shall have the following properties

- Light weight
- No gap shall be visible between adjacent tiles & shall be flushed with each other
- The insertion & removal of the control tile in the mosaic grid shall be fast, simple and without causing damage to the tile or its color
- It shall be possible to easily change the mimic display
- It should be easy to clean with water or soap

6.2.2 Large Video Screen (LVS)

Large Video Screens in the control room shall be used for the display of important data, graphics from the Operator Work Station (OWS), Engineering Work Station (EWS) or other Computer Based System. The LVS should be rugged and meant for industrial purpose and it should be able to work continuously (24 x 7) and should be of state of the art technology.

Size available for mounting the LVS will be maximum 1584 mm (W) and 888mm (height). 70" diagonal screen size and resolution of 1920 x 1080 pixels with 16.7 million colors and 16: 9 aspect ratio. The weight shall not be more than 80 kg.

Power consumption of LVS should be less than 750 watts

The brightness uniformity shall be > 85 % and minimum luminous intensity of each LVS module should be 600 cd/m² (Typical), with contrast ratio equal to better than 1500 : 1.

LVS should be provided with additional thermal protection and internal temperature sensors to meet the 24 x 7 application.

The LVS shall be capable to show the same images of OWS running on windows NT/XP/2000/LINUX Image windows should be freely resizable and positioned on any part of the Video wall with PAN, CROP and Zoom facility with 4 Window PIP feature through high bandwidth network.

Control of the LVS should be from a dedicated wall management HMI having a keyboard & mouse and through high speed network and image hubs.

The complete system shall be interfaced on 10/100/1000 Mbps LAN as well as there should be provision of integrating RGB/component video. Minimum Full

HD Video shall be made available in the control room through high bandwidth network.

The LVS should consist of the control ware like high bandwidth gateways and hubs and Controller and the wall management software, which should be supplied from a single manufacturer to avoid compatibility issue. The display must contain on-screen text-based menu system for easy access and control of all command function within the display and operated through remote control unit.

System should incorporate user friendly set up and maintenance tools such as universal remote control for image alignment to reduce downtime and ease in maintenance. Facility of RS-232/RS-485 port for calibration & control should be provided.

Large Screen should accept multiple DVI inputs and should have loop through output. All network components like gateways, video gateways & hubs should have a loop through output.

Graphic Controller

Graphic controller is used for displaying windows/Linux applications directly onto the LVS. Those applications can be installed directly on to the controller, or hosted on remote workstations connected to the LAN. Display of LAN based applications shall be ensured by LVS management software. With controller, the LVS should become the default display unit of the workstations.

The Controller should be based on open architecture, open source, future-proof with provision for up-gradation in an industrial 4U 19" rack mounted casing based on Intel i5/i7 with clock speed not less than 3 GHz and FSB should be higher than 800 MHz. (This information is provided only for guidance).

The RAM should be DDR3 SDRAM and should not be less than 4 GB, expandable up to 16 GB.

The unit should be equipped with a DVD/RW Drive and minimum 6 numbers of USB2 Ports. The hard Disk should be of 2-TB SATA, 7200 RPM. The system shall work on redundant power supply of 240 V AC ($\pm 10\%$ variation), 50 Hz. In case of failure of one power supply auto switchover shall be provided.

It should have minimum 5 numbers 10/100/1000 Mbps Ethernet port for LAN connection. It shall be supplied with an industrial Keyboard and mouse. It should have Dual DVI Input card/quad analog video card and quad SDI Video Card to allow multiple DVI graphics to be connected to the multiple LVS modules and the no. of such graphics outputs should be equal to the number of modules. There should be a possibility to drive max 16 numbers XGA module or max 8 numbers

SXGA+ modules from the controller. It should support different types of protocols such as TCP/IP, UDP IGMP etc.

Keyboards

One number of keyboard one each on LVS MCR panel shall be provided having inbuilt Hula-point in it, this will be used by the operator while carrying out the operations from the MCRPs. The second keyboard of each LVS is mounted as the third keyboard in the retractable tray arrangement in Operator Console with monitors. The key-board provided on OC is for doing the sitting operation from the OC by the operator. These keyboards shall be of i-Key make having inbuilt Hula-point in it. The necessary arrangement required for integration of these two keyboards with the controller/PC for LVS shall be done by the supplier.

Management Software

The software should able to pre configure various display layouts and access them at any time with a simple mouse click. It should enable the users to see the desktop of the graphics display wall remotely on any computer connected with the Display Controller over the Ethernet and change the size and position of the various windows being shown.

Specification compliance Format

Sr. No.	Description	Specifications	Compliance
1.	Make	Bidder to specify	
2.	Number of LVS	5 numbers per unit	
3.	Display Technology	LCD/LCD with LED array backlighting	
4.	Mounting	On Main Control Room Panel	
5.	Display Resolution	Full HD (1920 x 1080px)	
6.	Aspect ratio	16 : 9	
7.	Diagonal of Screen	70"	
8.	Weight	< 80 kg	
9.	Screen Type	Wide View Screen	
10.	Full viewing angle	>178°	
11.	Response time of the system	≤ 8 ms	
12.	Brightness	600 cd /sq.m	
13.	Brightness uniformity	> 85 %	
14.	Contrast ratio	Minimum 1500 : 1 or better	

NUCLEAR POWER CORPORATION OF INDIA LTD.

TECHNICAL SPECIFICATION FOR MAIN CONTROL
ROOM PANELS OF 700MWe PROJECTS

PAGE NO : 16 of 39
REV. NO. : 2

Sr. No.	Description	Specifications	Compliance
15.	Colors	16.7 million	
16.	Operating temperature	5° C to 45° C	
17.	Operating Humidity	0 to 90 % RH non condensing	
18.	Power Consumption	< 750 Watts	
19.	Remote Control	Required	
20.	Self Adjustment of Video Wall	Required	
21.	Auto Color balancing	Required	
22.	Auto Brightness Control	Required	
23.	Input	Analog VGA to full HD, DVI-D (with loop through), Composite video, Component video , RCAx3 S-Video, SDI , BNC with loop through	
24.	Output	RGBHV, DVD/HD , Composite Video	
25.	Display Control	RS-232/RS-485/IR-Remote/	
26.	Integrated Architecture	Required (bidder to attach architecture)	
27.	Parallel Processing (in case if controller fails then LVS should show the outputs from CCTV / WS / Video with same operational features)	Required	
28.	Power Supply	240 VAC @ 50 Hz (with ± 10% variation in power supply)	
29.	Complying to Safety regulations	UL, cUL, FCC Class A, CISPR22, CE, EN55022	
30.	Complying to EMI/EMC requirements	CISPR 11, IEC 61000	
31.	Complying to ISO standards IS 9000,ISO14001 &ISO 18001	Required	
32.	Temperature of CPU	Needed, Software based	
33.	Frequencies	Needed, Software based	
34.	On Screen Diagnostics	Required	
35.	Comprehensive on Site Warranty And spare parts	5 years	

6.2.3 Synchroscope

Design	:	Suitable for tropical conditions
Mounting	:	Suitable for mounting on mosaic control tile grid Structure & flush mounting.
Mounting altitude	:	Vertical.
Shape & size of Individual meters	:	Square, 96mm x 96mm
Accuracy	:	± 2% FSD
Supply voltage	:	110V ± 20 VAC
Supply frequency	:	50 Hz
Insulation resistance	:	More than 100 MΩ at 500 VDC
Indication	:	Slow and fast by direction of revolution of pointer.
Mechanism type	:	Ironless electro-dynamics cross coil
Voltage proof test	:	1.5 KV AC for a minute
Applicable Standard	:	IS-1248, BS-89

Synchroscope shall include double scale voltmeters and double scale frequency meters. Voltmeters shall be moving iron type. Frequency meter shall be vibrating reed type. Voltmeters shall have input signal range of 0-150 VAC and accuracy class 1.0. Frequency meter shall have reed at every half cycle.

6.2.4 Rotary hand switches of 4 positions and more

Type	:	Open execution (without enclosure)
Mounting	:	Suitable for mounting on mosaic control tile grid structure & flush mounting
Handle	:	Black colored knob with white arrow and Red colored knob with white arrow
Panel area	:	48 mm x 48 mm (max.) including escutcheon plate

No. of positions	:	a) Four (90 ⁰ angle between positions) Position 1: 12'0 clock position Position 2: 3'0 clock position Position 3: 6'0 clock position Position 4: 9'0 clock position b) For more than 4 positions, supplier may suggest angle between positions
Torque requirement	:	3.5 Kg Cm
Contact arrangement	:	As per elementary drawings (ED), Instrumentation loop diagrams (WD) & loop schematic drawings etc
Body material	:	Flame retardant, halogen free, resistant to fungus & termites
Contact rating	:	Thermal rating: 2 Amps, Making and breaking Current of 2 amp at 24 VDC for inductive loads of L/R = 15 ms
Contact resistance	:	Less than 15mΩ
Contact material	:	Suitable for one million operations
Duty	:	Continuous
Insulation resistance	:	More than 100 MΩ at 500 VDC
Dielectric strength	:	1.5 KV AC for one minute
Terminals	:	Suitable for back panel wiring with ring lugs
Applicable Standards	:	IEC: 60947 IEC: 408 IEEE: 344 JSS : 51208

6.2.5 Pushbutton switches

Type	:	Enclosed version
------	---	------------------

Mounting	:	Suitable for mounting on mosaic control tile grid Structure & flush mounting
Knob	:	Colored knobs Red, Green, Black, Blue, Grey and Amber. Some pushbutton switches are required with key
Panel area	:	48 mm X 24 mm
Contact Arrangement	:	i) 2 NO + 2NC ii) 3 NO + 3NC iii) 3 NO + 3NC + one changeover iv) 6 NO
Body material	:	Flame retardant, halogen free, resistant to fungus and termites
Contact Rating	:	Thermal rating 2 amps. Making and breaking current of 2 Amp at 24VDC inductive loads of L/R = 15 ms
Contact resistance	:	Less than 25mΩ
Contact material	:	Suitable for one million operations
Duty	:	Continuos
Insulation resistance	:	More than 100 MΩ at 500 VDC
Dielectric strength	:	1.5 KV AC for one minute
Applicable Standards	:	IEC : 408 IEEE : 344 IS : 6875

6.2.6 Annunciator Window Tiles

Type	:	Enclosed version
Mounting	:	Suitable for mounting on Mosaic control tile grid Structure & flush mounting
Panel area	:	48mm X 48 mm (max.)
Color of glow	:	White, Green and Red

Operating Voltage and Current	:	24 VDC and 60 mA
Connection terminal and wiring	:	Gold plated connectors with flexible wires/cables
Duty	:	Continuous
Inscription	:	As per text (Laser printed)
Mechanical life	:	100000 hrs at 25° C

For the window engraving details refer the Tech Spec PC-E-319.

6.2.7 Discrepancy switches

Type	:	Discrepancy type with built in lamp
Mounting	:	Suitable for mounting on Mosaic control tile grid Structure & flush mounting
Panel area	:	48mm X 48 mm (max.)
No. of positions	:	Four
Contact rating	:	2 Amp at 24 VDC, inductive loads of L/R of 15 ms
Contact resistance	:	Less than 15 mΩ
Duty	:	Continuous
Insulation resistance	:	More than 100 MΩ at 500 VDC
Dielectric strength	:	1.5 KV AC for 1 minute
Mechanical life	:	3 x 10 ⁵ operations

6.2.8 Semaphore indicators

Type	:	Supply failure indication type
Mounting	:	Suitable for mounting on mosaic control tile grid Structure & flush mounting

- Panel area : 48mm X 48 mm (max.)
- Coil voltage rating : 24 VDC
- Thermal rating : 120 % of rated voltage continuously
- Mechanical Requirement : High operating torque & positive action
- 6.2.9 Indicating meters** : As per NPCIL Spec. PC-E-316
- 6.2.10 Paperless Recorders** : As per NPC Specification PC-E-317
- 6.2.11 Indicating Lamp Assembly:** As per NPC Specification PC-E-318
- 6.2.12 Hand Controllers** : As per NPC Specification PC-E-451
- 6.2.13 Controllers** : As per NPC Specification PC-E-452
- 6.2.14 Temperature Transmitter with built-in display** : As per NPC Specification PC-E-298
- 6.2.15 Timer Module** : As per Project/63480/2011/ISS
- 6.2.16 Instantaneous Relays:** As per NPC Specification PC-E-298
- 6.2.17** Filler panels to bridge the gap between top of panels & false ceiling, also between corner MCR panels shall be provided. Measurement for filler panels shall be taken after installation of MCR panels at site. Refer the drawing Project/66100/2002/GA for the details and arrangement of the fillers. The material used for the Fillers shall be steel plates of 3 mm thick.
- 6.2.18** Provision of the necessary graphic lines/symbols/system division lines indicated on the GA drawings of the panels.
- 6.2.19** Required hardware like bolts, nuts, lock washers etc. for joining assemblies together.
- 6.2.20** Minimum 10 % of spares for each type of tiles, equipment / components and wires shall be supplied along with final delivery of panel(s) to site. Contractor is also required to supply additional requirement of engraved name plates which may arise after the shipment of panels to site subject to maximum of 10 % of total number of name plates supplied along with panels.

6.2.21 Modification in the MCR/BCR panels to match with final design drawings (frozen EDs)

Panels will be manufactured, wired & supplied to site with available design. For the first 700 MWe Nuclear Power Plant, some changes are expected in the final frozen design like addition/deletion of controls & indications, associated addition/deletion in wiring, modifications in existing components & their layouts in the MCR panels etc. This above work is to be carried out at site after installation of panels.

Maximum modification work to be carried out will be 7 % of total work.

6.2.22 Ten copies of catalogues as “Instruction Manual” of all the tiles instruments/components procured and mounted on these panels along with the soft copy of the document.

6.2.23 Five copies of Inspection History Docket along with the **softcopy**.

Inspection History Docket shall include;

- a) PO Copy
- b) QS Reports
- c) List of drawings (Manufacturing and NPCIL approved)
- d) Stage Inspection Reports and Component Inspection Report (Self certification by the supplier and CIRs for source inspected equipment)
- e) Design Concession Requests (DCRs)
- f) Test Reports
- g) Shipping Releases

6.2.24 One transparency, six prints and a softcopy of all drawings as per accepted distribution.

6.2 Contractor shall furnish the following:

For Approval:

- Structural details drawing showing the details of mounting of instruments/components and sub-assembly details at the inside/rear of panel, TB etc. Arrangement and details drawing no. Project/66100/2001/GA shall be referred as guidance. These drawings will be needed for seismic analysis; hence **these drawings are to be sent to contactor consultants by contractor for seismic analysis.**
- Bill of material of the above
- GA drawing showing the location of all instruments/components along with dimensions on the front of panel
- Bill of material of the above

- Name plate drawing
- Test procedure
- Quality Assurance Plan

For information and records

Panel wiring diagram : 5 copies
 Test reports : 5 copies
 Instruction Manuals : 10 copies
 History Docket : 5 copies
 Soft copy of each of the above shall also be submitted.

6.4 Purchaser's Documents

- Two prints of all the drawings pertaining to this job such as EDs, loop schematics, GA, BM etc.
- One print of cutout drawings of items to be mounted at site.

6.5 Seismic Requirements

The seismic qualification of the panel shall be done by the contractor **by any one of the following methods.**

6.5.1 Seismic Qualification of panel

6.5.1.1 Seismic Qualification of complete panel by testing

Complete panel may be seismically qualified by testing for Safe Shutdown Earth quake (SSE) as per floor response spectrum of 111M EL of CB and 109M of RAB.

When complete panel is tested for SSE requirement, separate seismic qualification of instruments is **not necessary.**

6.5.1.2 Seismic Qualification of panel by analysis & testing

Panel may be seismically qualified by analysis for Safe Shutdown Earth quake (SSE) as per floor response spectrum of 111 M EL CB and 109M EL of RAB.

In this case, the instruments shall be tested by seismic testing on shake table. The instruments must operate satisfactorily during and after the vibration tests for safe shutdown earth quake. Test frequencies and peak acceleration will be furnished later.

6.5.1.3 Acceptance Criteria

Panel shall be thoroughly inspected for any permanent deformation, dislocation of components, breakage of components and major cracks etc.

After the seismic test, hand switches and pushbuttons must be operable as before testing. All channels of the recorder must record constant output as before and during the test. Output of the hand controllers must remain constant as before and during the test.

- a) There should not be permanent deformations, dislocations, breakage and major cracks in the panel and Grid. Grid & Control Tiles should be intact after the test, though few blank tiles may fall or come out of their location.
- b) The duration of change in status of contacts(chatter) of hand switches shall not be more than 1 msec. This shall be judged from the output of the contact monitor.
- c) The duration of change in status of contacts (chatter) of pushbutton shall not be more than 1 msec. This shall be judged from the output of the contact monitor.
- d) All LEDs must be illuminated as before resting.
- e) After seismic test each selected test item must be operable exactly as before testing.

6.6 Structural Design

6.6.1 Drawings

The detailed structural design shall be the complete responsibility of the contractor. The purchasers' drawings shall be used only as a guide. It must be ensured that the overall dimensions given in the purchasers drawings are not changed without the permission of the purchaser. Detailed structural drawings prepared by the contractor are required to be sent for our approval. Also these drawings required to be sent to consultant for seismic analysis.

6.6.2 Fabrication

A higher than usual density of instruments is called for on the panels. To achieve the layout required by the purchaser, non-useable areas of panel shall be kept to the minimum.

The metallic mosaic grid work shall be suitable for accepting the mosaic control tiles. Mosaic grid framework shall be sturdy and shall withstand seismic forces as per the SSE floor response spectrum.

The finished panels shall be free from wrapping or distortion. Angle iron framework at the junction of the slopping and vertical portions of the panels shall not be used. The plate whenever required can be bolted/welded or bent to give sufficient rigidity.

Bend backs shall similarly be arranged to allow the maximum use of the panel area. Dimensional tolerances of the overall dimensions shall be as mentioned in relevant GA drawing.

The inside of panel shall be as open as possible to give complete access to the instruments. It is recognized that steel frame work may be necessary to support the larger instruments, wire bunches and terminals blocks, but this should be kept to a minimum. The panel rear shall be enclosed with the gasket hinged doors. Two numbers of doors shall be provided. **At the bottom side of the doors exhaust fans shall be provided & at the top side of the doors cooling fans shall be provided. The capacity of each fan shall be 450 m³/hr minimum.**

The panels are to be firmly fixed to the steel embedded sections on the floor through **welding after alignment**. Coupling of all the panels shall be ensured as per the arrangement shown in the control centre layout drawing no. Project/66000/2001/GA. Grouting holes shall also be provided at the base of the panel as shown in drg. No. Project/66100/2002/GA.

On the bottom front of panel, flush lift-off access covers shall be provided on the front side. The covers shall be retained by concealed key ways at the bottom and by slotted machine screws at the top. A lip running along part of the length shall be provided at the back of each access cover for handling purposes. A 3 mm thick plate is satisfactory for these covers. Panels shall be covered at top with suitable thickness steel plates.

Hand rail shall be provided at the front edge of sloping section of the panel. The hand rail tubing shall be 34 mm in diameter (OD) and made of a fire resistant material of black colour. Hand rail shall be fixed to panel thru' brackets suitably.

6.6.3 Painting procedure

On completion of fabrication, all steel work shall undergo following process

- a) Pretreatment by seven tank process.
- b) Undercoat and painting.

Details are as follows.

6.6.4 Pretreatment by seven tank process

Heavy deposits of grease, oil and rust shall be removed manually.

6.6.4.1 Degreasing

Surface cleaning to remove oil, grease, dirt and swerve from assemblies shall be done by either of following methods.

- a) Trichloroethylene cleaning as per clause 7.1.2 of IS-6005-1970 or
- b) Alkaline cleaning as per clause 7.1.3 of IS-6005-1970

6.6.4.2 De-rusting

Rust may be present after degreasing owing to exposure to corrosive conditions during manufacture. Scale may be present from operations during manufacture. It is therefore, necessary that rust be removed before application of phosphate treatment.

Derusting shall be done by chemical treatment method as per clause no.8.1.2 of IS-6005-1970. Supplier may adopt either of the following methods.

- a) Sulfuric or hydrochloric acid pickling as per clause no.8.1.2.1 of IS-6005-1970

OR

- a) Phosphoric acid pickling as per IS-6005-1970
- b) Duplex sulfuric and phosphoric acid process as per clause no.8.1.2.3 of IS 6005-1970

6.6.4.3 Sand blasting may be done instead of degreasing and derusting as given in 6.6.4.1 & 6.6.4.2 Procedure for sand blasting is as follows:

- a) The sandblasted surface shall be free of visible scale, rust, paint or other foreign matter
- b) The sand employed for blasting shall be from river bed, dry, hard and of a low breakdown rate and free from foreign matter. Preferred particle size of sand shall be 0.8 to 1.6 mm
- c) The compressed air used for blasting shall be dry and clean
- d) The surface, after completion of the cleaning operation shall be free from sand particles
- e) Phosphate coating shall be applied within 24 hours of blasting

6.6.4.4 Phosphate treatment

The phosphate treatment shall be carried out in such a manner that coating formation is proper as per **class C** vide under clause 3.1.4 of IS-6005-1970. Proper attention shall be given to time of phosphating, solution temperature and composition for required coating formation. The coating weight shall be in accordance with IS-3618-1966.

6.6.4.5 Rinsing and Chromate passivation

After phosphating, thorough rinsing with water is necessary in order to remove soluble salts which would otherwise tend to promote blistering under a paint film. Care should also be taken to ensure that the water supply itself is sufficiently free from harmful salts. Then the components shall be used in hot dilute chromate solution as per clause no.4.4.1 of IS-3618-1966 under a temperature not below 60⁰ C.

6.6.4.6 Undercoat and painting

Supplier may adopt either wet painting in hard glass alkali based synthetic enamel or powder coating. Supplier shall submit detailed procedure before starting the job.

6.6.5 Mounting of bigger instruments

For bigger instruments like controllers and recorders, support brackets may have to be added wherever necessary to ensure rigid mounting of the same. The contractor shall be responsible for the detailed design and providing of such supports.

6.6.6 Mounting of Accessory Units

Some of the instruments are to be mounted at the rear of the panels. The contractor shall locate and wire these units suitably and provide the necessary fixtures and mounting hardware.

6.6.7 Drawer & Writing Pad

For storing, drawer of suitable dimensions shall be provided on alternate panel on the left-hand side front cover. Drawer shall be provided with hinged cover so that drawer can be used for both purposes. For writing a retractable writing pad shall be provided on alternate panel on just above the drawers.

6.6.8 Telephone

Telephone mounting arrangement shall be provided on alternate panel on the left hand side of sloping panel.

6.7 Electrical Design

6.7.1 Cable Entry

All cables will enter and leave from **bottom**. Cables are in generally multi-color twisted pair types. Majority of cables being 50 pair 1.50mm² and 25 pair 1.50mm² cable, diameters will not exceed 50mm. Contractor shall devise to take the cables thru glands at the bottom panel and run suitably inside to the termination points. (Refer drawing Project/66100/2001/GA).

6.7.2 Terminal blocks for connections

Terminals to be used for signal and power supply connections to the instruments/components shall be screw type, suitable for taking conductor upto 4 sq. mm. Terminal blocks shall be non radiation resistant type as per NPC specification PC-E-409. The terminals carrying voltage of 120 volts and above shall be provided with suitable protective covers so as to prevent any danger to personnel due to inadvertent contact with the same. Also physical separation shall be provided between DC and AC supply terminals. Cable to cable connectors shall be provided for all the 240 VAC loads, between the instrument and the terminal block as shown in the structural detail drawing.

Wires terminated by the Contractor shall be connected with care. The correct torque as recommended by the terminal block manufactures shall be applied by torque limiting screw drivers, which shall be checked by a suitable standard at frequent intervals.

6.7.3 Wiring

6.7.3.1 Wiring of mosaic control tiles

The control tile components shall be brought out to the field terminal blocks provided in the MCR panels by Poly tetra Fluoro Ethylene (PTFE) Teflon, insulated wires of 20/22 AWG.

6.7.3.2 Wiring of equipments other than mosaic control tiles

As currents are low and voltage is not higher than 240 VAC, 20 AWG standard conductors with PTFE (Teflon) 600V grade suitable for maximum conductor temperature of 150° C shall be used.

When a single wire at the panel terminal strips is to be multiplied for connections to various equipments the same shall be done by a jumper at terminal strips and not by looping the wire from equipment to equipment.

All connections to instruments or switches where screw posts are provided shall have crimped AMP or equivalent connector fixed on the wires.

Wherever space permits, plastic raceways may be supplied. Otherwise neat assembly of wires cleated together with nylon/PVC straps shall be provided. The maximum distance between such anchoring points shall not be more than 100mm. Unused areas of panel shall be kept free of wiring to facilitate the installation of future equipment; wiring between points shall be point to point with no splicing or T connections.

The contractors shall connect all instruments/components with sufficient looped slack to permit the withdrawal of the instrument/component from behind or beneath the panel for maintenance, test or alteration. The wires to any one component/instrument shall be neatly cleated together.

Wires shall be identified with double termination identity sleeves showing the two terminations of the wire. Such sleeves should be provided at both ends of the wire. Identification shall be marked in such a manner that it may be read easily from positions normally used when the equipment is being serviced. **Five number of wire troughs, one each per channel as shown in the structural detail drawing shall be provided inside the panel.**

The color code for these sleeves shall be as follows:

- a) Red-safety group-I (Channel D, E & F) wiring
- b) Sky blue- safety group II (Channel G, H & J) wiring
- c) White- Safety related (Channel A, B, C, Y & Z) wiring
- d) Yellow- for non-safety related (N & X) wiring

6.7.3.3 Wiring Channels, Cable dressing and Terminal Block supports

PVC wiring channels with cover shall be provided in each panel for routing of wires of Multi pair cables and Teflon wires. Wiring channels with cover shall be provided such that all the wires can be routed in these wiring channels only and can be dressed and securely supported by lacing to form a tight bunch of wires.

6.7.3.4 Plating of Hardware

All hardware shall be cadmium plated or suitably treated to prevent rust and corrosion.

The supplier shall follow the following standards for hardware plating:

- IS-1572-2006 : Specification for electroplated coatings of cadmium on Iron and Steel (for non-threaded parts). Grading of service condition – severe
- IS-3655-2006 : Recommended practices for electroplating

BS-3382-2006 : Electroplated coating on threaded components Part-I-
Cadmium on Steel Components.

6.7.4 Grounding

Each instrument or device having an electrical grounding terminal shall be connected thru' insulated wire to a common ground bus provided in the panel for connection to station ground as described below:

All the panels shall be provided with a switch board ground bus of bare copper strip of size not less than 25 mm X 6 mm. The switch board ground bus shall be mounted horizontally in the panels. It shall be connected to sheet steel metal framework by means of mild steel and off parts of 50 mm height provided at regular intervals. These parts shall be connected to panel framework by welding before the panels are painted. The bus bar shall have tapped holes at regular intervals along its length to enable termination of safety ground connections from different equipments in panel through green color PVC insulated stranded copper 4 Sq.mm. by crimpable lugs. A single connection of 16 Sq.mm bare copper wires through crimpable lug shall be made between switchboard ground bus to nearest grounding bus. The bus bars of adjacent control panels shall be inter-connected through side openings by means of copper strips of same size.

6.7.5 Miscellaneous items

6.7.5.1 Name Plate/Tagging modules

For tiles modules, tagging modules shall be provided. Tagging tiles shall be used for identification of switches, push button modules etc. Complete name plates/tagging modules designation for each instrument/component is shown on the equipment arrangement drawing of each panel. Abbreviations as per purchaser's specification PC-E-123. "Common abbreviations" is allowed to be used wherever necessary in order to accommodate within the space available.

Whenever tagging modules cannot be used, the material for the name plate on the panel shall be 1.6 mm thick, 3 ply black white black hylam (laminated) or 1.6 mm thick black anodized aluminum with matter engraved. The front edges shall be chamfered to 0.5 x 45° to get a uniform border. Name plates shall be black with white characters. Basic material either Hylam or aluminum, type of characters, size of characters and depth of engraving shall be subject to purchaser's approval.

The name plate shall be fixed with blackened pan head screws or with the use of suitable adhesive depending on the size of the name plates. In case of adhesive fixing, it shall be ensured that the adhesive will have sufficient bonding strength and also it is possible to remove the fixed name plate for replacement or deletion by applying white petrol at the joint without causing damage to painting on the

panel.

Care shall be taken to ensure that name plates/tagging modules are located in an orderly manner with proper spacing from the equipment to maintain the aesthetic look.

6.7.5.2 Power Supply for service Sockets, illumination & ventilation:

Suitable facility shall be provided for loop in & loop out of a 240 VAC cable for service socket, illumination & ventilation.

6.7.5.3 Service Sockets

240 VAC, 5 amps 3 pin power sockets shall be mounted inside each panel, two at the front and two at the rear. These shall be wired to the 240 VAC terminal blocks as given in the terminal list of each panel. These sockets are meant for servicing and testing of the instruments mounted on the panels.

6.7.5.4 Illumination

Each panel shall be provided with Special RFI suppressed high beam LED interference free lighting fixtures rated for 240V AC, 50 Hz, 10 watts, single phase supply for interior illumination of cabinet during termination of wire/cables and maintenance.

The switching of the light shall be controlled by the cabinet door switch. The scheme shall be such that whenever panel doors are opened, the panel light gets switched ON automatically.

6.7.5.5 Ventilation inside the panel

Instrument fans shall be provided for sucking the air at the bottom of panel & exhausting at the top ends of panel. These will be powered by 240VAC supply. Suitable terminals shall be provided for connecting 240VAC supply.

6.7.5.6 Mimics

Mimic symbols and system division lines shall be provided as indicated on the panels (equipment GA drawings). The details of color, width and size of symbols etc., shall be as shown on the above drawings of these panels. Symbol tiles diagrams shall be used for mimics.

6.7.5.7 Finish

Structural steel and external panel surface shall be painted with baked enamel

paint according to procedure approved by the purchaser. Two different color shades i.e. Velum and Opaline green (Shade nos. 365 and 275 respectively as per IS-5) are recommended for first and second respectively to distinguish between the two units as per earlier site feedback. The internal panel surfaces are painted with enamel paint of Velum color shade (shade no. 365 of IS-5). Thickness of the finish paint shall be minimum of 25 microns. Composite film thickness (i.e. including, all under coats) shall be 70 microns minimum. On inside surface thickness shall be 40 microns minimum. Support members, brackets etc. used inside the panel as standard items of the manufacturing shall be plated as per clause 6.7.3.5 of this document.

6.7.5.8 Handling provisions

The panels shall be provided with removable lifting gadget for hoisting from the top. The holes provided for lifting gadgets can subsequently be used for mounting filler panels.

6.7.5.9 Mounting and anchoring requirements

In the control center embedded parts have been provided in the floor. The panel shall be mounted and firmly fixed to these embedded sections by welding after alignment.

7.0 INSPECTION, TESTS AND REPORTS

Quality surveillance relating to all aspects of manufacture shall be carried out by NPCIL. The supplier shall provide all the testing and inspection services and facilities satisfactorily as required. Inspection shall be carried out in a satisfactory manner and shall be subject to approval by the purchaser. Supplier shall carry out all the tests as per indicative quality assurance plan (QAP) enclosed herewith as Annexure-C.

Purchaser or his authorized representative shall have access to contractor's premises at all reasonable times to the extent necessary to assess compliance with the provision of this specification. Purchaser shall also have the right to conduct at Purchaser's expenses any additional inspection & testing.

7.1 Inspection

In the event of failure of the product or any part to fully meet any inspection or test requirement specified herein, the contractor shall notify the purchaser or his authorized representative his intention to repair and/or use such product or part, and such repair or use shall be subject to approval by the purchaser. If the repairs, including redesign are likely to effect the results of tests or work previously completed, appropriate reinspection and retesting shall be conducted.

The control panels shall be carefully examined to determine conformance with this specification with respect to material and workmanship, finish, marking, dimensions and to assess its conformance with other requirements stated or reasonably implied and not covered by specific tests.

8.0 Tests

The contractor shall notify the purchaser of his intention to carry out tests, giving sufficient notice to enable purchaser's representative to be present and shall be carried out as per requirement detailed below:

8.1 Process Check

8.1.1 Visual Checking

Visual checking shall be done on sheet steel, fabrication process and painting as per enclosed QA plan.

8.1.2 Dimensional Checking

Dimensional checking shall be done on sheet steel and panel as per enclosed QA plan.

8.1.3 Weld Check

- a) Visual
- b) Liquid penetrate test shall be done as per NPC Specification.

8.1.4 Pretreatment Check

Pretreatment shall be done as per clause no 6.6.4 of this specification.

8.2 Type test

8.2.1 Painting Thickness Check

Painting thickness shall be checked as per IS-101. Thickness shall be as per clause no.6.7.5.7 of NPC specification.

8.2.2 Scratch Hardness Test

Scratch hardness test shall be conducted as per clause no. 3.0 of IS-101-1988 on test coupon.

8.2.3 Bend (Flexibility) Test

Bend test shall be conducted as clause no. 2 of IS-101-1988 on test coupon.

8.2.4 Pull off (Adhesion) Test

Pull off test shall be conducted on test coupon as per clause no. 5 of IS-101-1988.

8.2.5 Salt Mist Test

Salt mist test shall be conducted for the resistance to corrosion on test coupon as per part-11 of IS-9000-2007.

8.3 Special Type Test

Seismic test shall be carried on one of panel as per clause no. 6.5 of specification.

8.4 Alignment Test

After painting & before wiring all the MCR panels shall be aligned as per control centre layout drawing Project/66000/2001/GA. No gaps shall be visible.

8.5 Acceptance Test

8.5.1 Voltage Proof Test

Voltage proof tests between conductors and ground for one minute as follows

240 V AC circuits - 1500V 50 cycles.
24V DC circuits - 500V 50 cycles.

8.5.2 Insulation Resistance Test

Insulation resistance test shall be carried out on each panel by applying 500 V DC between the terminals and the panel. The same shall be more than 10 MΩ.

8.5.3 Continuity Check

Continuity checks for wiring errors shall be carried out.

8.5.4 Electrical and Mechanical Operation

Electrical and mechanical operation of all instruments / components shall be done.

8.5.5 Material and Component test

Material test certificates shall be furnished. All the components/Instruments used on main control room panels shall be subjected to visual, mechanical, Electrical & functional tests. The test results shall be documented and submitted to the purchaser's QA engineer for review. Details of the tests to be conducted shall be mentioned in QAP prepared by the supplier after award of contract.

Copies of test reports, signed by a responsible representative of the Contractor shall be submitted to the Purchaser, as per the general contract.

9.0 PACKING AND SHIPPING

9.1 General

The contractor shall make adequate provisions to protect the panels supplied to this specification to ensure that on arrival at the plant and after storage for 2 years it shall not have suffered corrosion or damage of any kind. All mounted instruments shall be adequately blocked where necessary/meter movements shorted to prevent damage during shipment. The panel shall be shipped by truck direct from contractor's works to the plant site.

9.2 Identification during shipment

The package(s) shall be clearly and legibly marked with the following information:

Purchaser's reference Number (Purchase order Number) :
Description and quantity of item :

10.0 Information required with bid

The supplier should give the technical details as per the format given in Annexure-A of this specification.

10.1 Delivery Period

As specified in the tender document.

10.2 Validity

As specified in the tender document.

Material of the control tiles	_____
Control tiles meet the technical requirement mentioned in clause no.6.2.1?	Yes/No
Dimensions & make of Synchroscope	_____
Synchroscope meet the technical requirement as per clause no. 6.2.3?	Yes/No
Dimensions & make of Rotary switch modules	_____
Rotary switches meet our technical requirement as mentioned in clause no.6.2.4?	Yes/No
Dimensions & make of push button modules	_____
Push button modules meet the Technical requirement as mentioned in clause no.6.2.5?	Yes/No
Dimensions & make of LED lamps	_____
LED lamps meet the technical Requirement as per clause no.6.2.11?	Yes/No.
Dimensions & make of discrepancy switch	_____
Discrepancy switches meet our Technical requirement on mentioned in clause no.6.2.7 ?	Yes/No
Dimensions & make of semaphore indicator	_____
Semaphore indicators meet the Technical requirement as per clause no.6.2.8 ?	Yes/No
Dimensions & make of indicating meters	_____
Indicating meter meet Technical requirement as per 6.2.9?	Yes/No
Dimensions & make of Recorder Recorder meet Technical requirement as per 6.2.10?	Yes/No

LVS meets the technical requirements as per clause no. 6.2.2.?	Yes/No
Terminal blocks meet Technical requirement as per clause no.6.7.2?	Yes/No
Wires meet our technical Requirement mentioned in clause no.6.7.3?	Yes/No
Grounding terminal provided ?	Yes/No
Mosaic control tiles and Other components meet operating Conditions mentioned in clause no. 6.2.1?	Yes/No
Panel structure meets seismic Requirement mentioned in clause no.6.5?	Yes/No
Components meet seismic Requirement mentioned in clause no.6.5?	Yes/No
Pretreatment procedure followed mentioned in clause no.6.6.4?	Yes/No
Insulation resistance value as mentioned in clause no.8.5.2?	Yes/No
The supplier can carry out all the acceptance tests listed in this specification in presence of purchaser and furnish test reports for the same.?	Yes/No
Can the supplier furnish test reports for all “type test “ listed in this specification.?	Yes/No
Painting procedure submitted	Yes/No
For components MTBF, MTTR, Nos. of Mechanical Operation, Nos. of Electrical operation provided	Yes/No

NUCLEAR POWER CORPORATION OF INDIA LTD.

TECHNICAL SPECIFICATION FOR MAIN CONTROL ROOM PANELS OF 700MWe PROJECTS

PAGE NO : 39 of 39
REV. NO. : 2

ANNEXURE-B

SAMPLE QUALITY ASSURANCE PLAN FOR MAIN CONTROL ROOM PANEL

SL. NO.	Component	Characteristics	Type of check	Quantum of check	Reference Document	Acceptance Norms value	Format of Record	Agency			Remarks
								P	W	V	
1.	Components Such as hand-switches Push buttons etc.	Visual Mechanical Electrical Functional tests	Visual for any defects. Dimensions. IR, VP. Operation.	Suppliers Standard.	Relevant National/ International standard	PC-E-314	Inspection Report.	2	1	1	
2	Sheet Steel	Visual Dimensional Checking Bend test Chemical Composition	Visual for any visual defects. Measurement Mechanical Chemical Analysis	All sheets All Sheets On sample On sample	PC-E-314 PC-E-314 IS-226 IS-228	PC-E-314 PC-E-314 IS-226 IS-228	Inspection Report	2	1	1	
							Inspection Report	2	1	1	
3	Fabrication	Weld check visual Liquid penetrate test	Visual for any visual defects	100%	PC-E-314 PP-E-1209	PC-E-314 PP-E-1209	Inspection Report	2	1	1	
				50% of weld	PC-E-314 PP-E-1209.	PC-E-314 PP-E-1209	Inspection Report	2	1	1	
4.	Painting	Pretreatment check Scratch hardness Check Bend (Flexibility) Test Salt Mist Test Pull of Adhesion test Painting thickness check	Process Physical	3.0 of IS-101	PC-E-314	PC-E-314	Inspection Report	2	1	1	Tobe conducted on test coupon -do- -do- -do-
				2.0 of IS-101	IS-101	IS-101	Test report	2	1	1	
			Mechanical	5.0 of IS-101	IS-101	IS-101	Test report	2	1	1	
				Part-11 IS-9000	IS-9000 PC-E-314	IS-9000 PC-E-314	Test report Test report	2	1	1	
5.	Special Type test	Seismic test	Vibration	Approved procedure	Approved procedure	PC-E-314	Test report	3	1	1	
6.	After Painting before wiring	Alignment test	Visual	All panels to be aligned.	Project/ 66000/2001/ GA.	Gaps shall not be visible. However, minor gaps are allowed.	Test report	2	1	1	
7.	Final Test.	Electrical Electrical Electrical Electrical	High voltage test Insulation Resistance test Continuity check Function check	100%	PC-E-314	PC-E-314	Test report	2	1	1	
				100%	PC-E-314	PC-E-314	Test report	2	1	1	
				100%	PC-E-314	PC-E-314	Test report	2	1	1	
				100%	PC-E-314	PC-E-314	Test report	2	1	1	

Note: Type test, MTTB, MTTR, Calibration Interval (wherever applicable), endurance (mechanical & electrical) certificates for all the components shall be furnished by the supplier.

- | | | |
|----|--------------|-------------------------|
| P- | Performed by | 1. Purchase (NPCIL) |
| W- | Witnessed by | 2. Prime Supplier |
| V- | Verified by | 3. External Laboratory. |

**NUCLEAR POWER CORPORATION OF INDIA LTD.
A GOVERNMENT OF INDIA ENTERPRISE**

SPECIFICATION NO. PC-E-298

REVISION NO.	:	0	1	
DATE OF ISSUE (MONTH/YEAR)	:	JANUARY 2009	NOVEMBER 2010	
TOTAL NO. OF PAGES (INCLUDING COVER SHEETS)	:	12	11	

**TECHNICAL SPECIFICATION
ON
ELECTROMAGNETIC RELAYS
FOR
700 MWE ATOMIC POWER PROJECTS**

REF.USI NO: 66310

PREPARED BY	:	MOHANDAS V., SR. EX. ENGR	Sd/-	(23/01/09)
CHECKED BY	:	A.V.UGHADE, ACE	Sd/-	(27/01/09)
REVIEWED BY	:	C.P.SHRIVASTWA, ACE	Sd/-	(30/01/09)
APPROVED BY	:	V.K.MINHAS, ACE	Sd/-	(30/01/09)
		(Name & Designation)	Signature	Date

(FOR REVISION SEE REVISION CONTROL SHEET)

FILE NAME: PC-E-298 R1.doc

REVISION CONTROL SHEET

DOCUMENT TYPE: TECHNICAL SPECIFICATION

NO.: PC-E-298 REV. NO. 1

TITLE: TECHNICAL SPECIFICATION ON

ELECTROMAGNETIC RELAYS

REV. NO. & DATE	DESCRIPTION OF REVISION	PREPARED BY NAME & SIGNATURE	CHECKED BY NAME & SIGNATURE	REVIEWED BY NAME & SIGNATURE	APPROVED BY NAME & SIGNATURE
1 November 2010	Revised to make the specification generic for all 700 MWe projects and to incorporate miscellaneous changes	<i>Mohandas V.</i> 16.11.10 Mohandas V.	<i>K K Chandra</i> 16.11.10 K K Chandra	<i>C.P. Shrivastwa</i> 16.11.10 C.P. Shrivastwa	<i>V.K. Minhas</i> 29.11.2010 V.K. Minhas

NPCIL PROPRIETARY

This document is property of Nuclear Power Corporation of India Limited. No exploitation or transfer of any information contained herein is permitted in the absence of an agreement with NPCIL and neither the document nor any information contained herein may be released without the written consent of NPCIL.

1.0 SCOPE

This specification establishes the technical requirements for the design, manufacture, inspection, testing and supply of the Electromagnetic Relays (herein after referred as relays) which form part of the various safety related systems, to be mounted in panels for use in control centre of 700 MWe Atomic Power Projects. In general, the scope covers the requirements of relays.

2.0 CONTENTS

The requirements of this specification are presented under the following section headings.

SECTION	TITLE	PAGE NO.
3.0	APPLICABLE SPECIFICATIONS	4
4.0	MATERIALS AND WORKMANSHIP	5
5.0	GENERAL FUNCTION & DESCRIPTION	5
6.0	REQUIREMENTS	5
7.0	INSPECTION TESTS & REPORTS	7
8.0	PACKING & SHIPPING	10
9.0	DOCUMENTATION	10
10.0	IDENTIFICATION	10

LIST OF ANNEXURES

ANNEXURE-I	QUALITY ASSURANCE PLAN (SAMPLE)	11
------------	------------------------------------	----

3.0 APPLICABLE SPECIFICATIONS

The specifications and standards to which the relays are manufactured shall be submitted by the supplier for approval and same shall form part of the requirement of this specification. The standards listed below constitute a part of this specification to the extent defined in subsequent sections. In case of any conflict, the requirements of this specification shall prevail over the requirements of these standards.

1. JSS-50700: General requirements for relays (excluding polarized and thermal)
2. IS-9000: Basic environmental testing procedure for electrical and electronic items. Part III & Section 2 of Part V
3. AERB SG-D1, Safety Classification and Seismic Categorisation for Structures, Systems and Components of Pressurised Heavy Water Reactors
4. AERB/NPP-PHWR/SG/D-23, Seismic Qualification of Structures, Systems and Components of Pressurised Heavy Water Reactors.
5. PP-E-2061-Technical Specification for Requirements of components for Instrumentation Items.

4.0 MATERIALS AND WORKMANSHIP

4.1 Materials

Materials shall conform to applicable national/international standards. The evaluation of components shall preferably be done by an independent agency. All components shall be 'Type approved' or shall have gone through satisfactory quality assurance test program and shall be in the currently produced list of products. As far as possible components shall be adequately derated.

4.2 Processes & Workmanship

Processes shall be backed by evaluation reports and workmanship shall be in accordance with high grade commercial practice adequate to ensure satisfactory operation for 40 years of plant life.

5.0 GENERAL FUNCTION AND DESCRIPTION

5.1 General

The relays are required for use in various electrical control logic circuits designed to control different reactor processes. The relays shall be panel mountable with suitable base sockets.

5.2 Relay Types

When control voltage is applied, transfer of contacts shall take place instantly. When the control voltage is disconnected from the circuit the output contacts shall return to the original state instantly (The permitted operation and release time for the relays shall not exceed 20 milliseconds).

The relays shall have 4 Form C (change over, break before make) contacts.

6.0 REQUIREMENTS

6.1 Operating/Control Voltages

Nominal: 24 V DC

Variation in Operating/Control Voltages: +15 % and -20% Nominal

6.2 Environmental Conditions

Normal operating conditions

Temperature: 8° to 45° C continuous operation

Relative Humidity: 20-90% non-condensing

Occasional operating and storage conditions

Temperature: 4° to 55° C

Relative Humidity: 20-95% non-condensing

6.3 Contact Rating

i) 2A - Inductive load of L/R = 15 ms at 24 VDC

ii) Contact resistance - ≤ 50 mohms

iii) Contact Bounce: ≤ 10 milliseconds (total), maximum duration of a bounce ≤ 2 milliseconds

6.4 Coil Power Consumption

≤ 2 W

6.5 Cooling

Free convection

6.6 Mechanical Life

≥ 1000000 operations with ≥ 1000 operations/hr

6.7 Electrical Life

≥ 100000 operations at rated load with ≥ 1000 operations/hr

6.8 Insulation Resistance

Insulation Resistance shall be ≥ 100 M ohms

6.9 Dielectric Strength

Dielectric Strength shall be ≥ 500 V AC, 50 Hz. For 1 minute

6.10 Socket Type

Suitable for back wiring, solder connection

6.11 Mounting Arrangement

Relays shall be suitable for mounting horizontally or vertically on the panel. A separate mechanical mounting arrangement shall be provided for mounting and electrical socket shall not be used for supporting the relay.

6.12 Enclosure

Relay enclosure shall be of fire retardant hard plastic material & dust proof

6.13 Sealing

The relay shall be dust tight plug-in type

6.14 Seismic conditions

The relays are to be mounted vertically on the panel and tested for seismic category 1 as per the floor response spectra for 111 M elevation of control building. (The floor response spectra will be furnished to the successful bidder at the time of placing the order).

6.15 Built-in free wheeling diode

The relays having built-in free wheeling diode across coils are preferable.

6.16 Indication

The relays shall have LED indication or flag to show its coil energized/deenergized status.

7.0 INSPECTION, TESTS & REPORTS

7.1 General

The supplier shall be responsible for and shall perform all tests and inspections mentioned in this specification and any other tests which may be necessary to assess the required performance of the product as per the detailed test procedure prepared by manufacturer and approved by the purchaser. The performance of the relays shall conform to this specification. The tests shall be witnessed by representative of NPCIL.

The supplier shall provide all the reasonable times to carry out the inspection or tests necessary for purchaser's quality surveillance.

Failure to meet the inspection or test requirements specified here in shall be reported to the purchaser and shall be considered as sufficient cause for rejection.

7.2 Inspection & Testing

7.2.1 Inspection

Relays and relay sockets shall be checked for mechanical and electrical requirements during incoming inspection stage.

7.2.2 Testing

7.2.2.1 Functional test

Functional tests shall be carried out under prevalent ambient conditions to check that relays conform to the requirements as given in section 6.0. Functional tests shall be done with relays mounted on their sockets.

- a. Contact operation of each relay (to be assured by energizing and de-energising relay electrically)
- b. Operate & release voltage of each relay
- c. Operate & release time of each relay
- d. Contact resistance of relay contacts at rated load

Test 'a' shall be done for each relay. Tests 'b', 'c' & 'd' shall be done on sample basis on relays selected randomly (as per sampling plan) from the lot.

7.2.2.2 Insulation Resistance Test

The insulation resistance of each relay shall be measured with the relay not connected to its supply source. A DC voltage of 500 V shall be applied between all its input/output leads shorted and chassis and the measurement shall be carried out. The IR measured shall be better than 100 M Ω .

7.2.2.3 Insulation Voltage Withstand Test

The RMS value of the test voltage shall be 500V. The test voltage shall be applied gradually to each relay, starting at 50% and increasing to full value in not less than 10 seconds between all its input/output leads shorted and chassis. There shall not be any flashover or insulation break down.

7.2.2.4 Burn in Test

The relays selected randomly (as per sampling plan) from the lot shall be subjected to burn in test. The relays shall be kept ON under prevalent ambient conditions, for a continuous duration of 100 hours for burn in test. The performance of each relay shall be checked for functional requirements before and after burn in test. There shall be no deviation from the requirements specified in this specification.

7.2.2.5 Seismic Test

The relays selected randomly (as per sampling plan) from the lot shall be subjected seismic test to demonstrate conformance to seismic conditions given in 6.14 after completion of tests mentioned in section 7.2.2.1, 7.2.2.2 & 7.2.2.3.

NUCLEAR POWER CORPORATION OF INDIA LTD.	
TECHNICAL SPECIFICATION ON ELECTROMAGNETIC RELAYS	PAGE 9 OF 11 REV NO.: 1

Tests to be done during Seismic Test

- i) Observe for contact failure (change of contact status for 1 millisecond or more is considered as failure).
- ii) Observe for physical change in the relay (damage etc.).
- iii) During vibration test 50% of the relays shall be maintained in de-energised state and observation shall be recorded.

After completion of the above carry out the following

- i) Conduct tests mentioned in section 7.2.2.1, 7.2.2.2 & 7.2.2.3
- ii) Perform visual checks on each relay.

7.2.2.6

Environmental Tests

The relays tested for seismic condition shall be subjected to climatic testing.

The relays selected randomly (as per sampling plan) from lot shall be subjected to climatic testing. The relays shall be tested for dry heat test and damp heat cyclic test as per the standard IS-9000. The condition for testing shall be as follows:

Dry heat (as per part III, section 5 of IS-9000 for heat dissipating items)

Temperature: $55^{\circ}\text{C} \pm 2^{\circ}\text{C}$

Relative Humidity: 50%

Duration: 4 hours

Damp heat (as per Part V section 2 of IS-9000)

Upper temperature: $40^{\circ}\text{C} \pm 2^{\circ}\text{C}$

Relative Humidity: 90%

Lower temperature: $25^{\circ}\text{C} \pm 3^{\circ}\text{C}$

Relative Humidity: 95%

Number of cycles: 2 cycles of 12 + 12 hours each

The recovery shall be under prevalent ambient conditions for 2 hrs.

Performance of relays shall be checked for functional requirements before and after the climatic tests. There shall be no deviation from the requirements specified in this specification.

The relays tested for seismic and climatic requirement shall be tagged separately and shall be in addition to the quantities required.

NUCLEAR POWER CORPORATION OF INDIA LTD.	
TECHNICAL SPECIFICATION ON ELECTROMAGNETIC RELAYS	PAGE 10 OF 11 REV NO.: 1

7.3 **Acceptance Criteria**

Acceptance of the relays shall be subjected to its meeting the specification and fulfillment of various requirements covered by this specification. The relays shall be shipped or used in fabrication for various jobs as covered in separate purchase orders only after a shipping release is issued by an authorized representative of NPCIL

8.0 **PACKING & SHIPPING**

The relays shall be so packed as not to suffer deterioration, damage or breakage during shipment. Packing shall be such that the ingress of moisture, dirt and other foreign material shall be avoided. Packing method shall be adequate to withstand a period in transit for more than three months and storage at site under tropical climate for minimum period of one year without suffering any damage or deterioration. Each package shall be clearly and legibly marked with the following information.

- Purchase order/Requisition number
- USI number
- Number of items in the box
- Description of the items

The supplier shall ship the material to the sites as notified in the purchase order. Supplier shall not ship the material, without the prior approval of the NPCIL or his authorized representative and subsequent instructions to do so. The supplier shall be required to provide transport insurance for the material.

9.0 **DOCUMENTATION**

The supplier shall furnish the details of the tests conducted in accordance with and mentioned in this specification. Five copies of all the test reports, signed by a responsible technical representative of the supplier shall be submitted to the purchaser.

The relay catalogues shall be a part of the Maintenance & Instruction Manual (MI) of the respective application system panels wherever these relays are used.

All documents shall be in English language.

10.0 **IDENTIFICATION**

The relays shall be used as per types and tag numbers as specified in each application system.

ANNEXURE-I **QUALITY ASSURANCE PLAN (SAMPLE)**

Sr. No.	Components & Operation	Characteristics	Type of Check	Classification	Quantum Of check	Reference Documents	Acceptance Norms	Format of record	Test Agency			Remarks
									P	W	V	
1	Material											
1.1	Relays	Visual	Defects	Minor	100%	Manufacture's Catalogue	No visible defects	Internal Quality Control records	2	2	1	
1.2	Sockets											
2	Electrical Test											
2.1	Relay with Socket	Functional	As per NPCIL approved procedure	Major	As per NPCIL spec	As per IP approved by NPCIL	As per NPCIL spec.	Test Reports	2	2	1	
		Insulation Resistance Test										
		Insulation Voltage Withstand Test										
	Burn in Test											
3	Environmental & Seismic											
3.1	Climatic Test	Functional	As per NPCIL approved procedure	Major	As per sampling plan	As per IP approved by NPCIL	Meeting NPCIL Spec.	Test Reports	2	2	1	The relay subjected to climatic tests shall be used for seismic test
3.2	Seismic Test (Simulating actual mounting position)											
4	PACKING											
4.1	Packing & Tagging	Visual	To ensure safe transport & Storage	Major	100%	As per IP approved by NPCIL	Meeting NPCIL Spec.	Test Reports	2	2	1	

Legend

P- Performed by
1-NPCIL QS

W- Witnessed by
2-Manufacturer

V- Verified by
3-Third Party

IP-Inspection Procedure

**NUCLEAR POWER CORPORATION OF INDIA LTD.
(A GOVT. OF INDIA ENTERPRISE)**

SPECIFICATION NO.PC-E-318, REV NO: 1

**TECHNICAL SPECIFICATION
ON
INDICATING LAMP ASSEMBLY
FOR
700MWe ATOMIC POWER PROJECTS**

REF. USI NO: 60483

REVISION NO:

DATE OF ISSUE

TOTAL NO. OF PAGES
(INCLUDING COVER
SHEET)

0	1			
MAR 2010	NOV 2010			
17	18			

PREPARED BY: VIRENDRAKUMAR

WANKHEDE, EE (SCI)

(sd/-)

19-03-2010

CHECKED BY: C.P. SHRIVASTWA, ACE (SCI)

(sd/-)

19-03-2010

REVIEWED BY: A.V. UGHADE, ACE (SCI)

(sd/-)

22-03-2010

APPROVED BY: V.K. MINHAS, ACE (SCI)

(sd/-)

23-03-2010

(Name & Designation)

(Signature)



(Date)

(FOR REVISION SEE REVISION CONTROL SHEET)

FILE NAME: PC-E-318-doc.

REVISION CONTROL SHEET

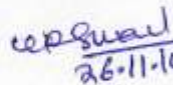
DOCUMENT TYPE : TECHNICAL SPECIFICATION
DOCUMENT NO : PC-E- 318, REV-1
TITLE : TECHNICAL SPECIFICATION ON
INDICATING LAMP ASSEMBLY FOR
700MWe ATOMIC POWER PROJECTS

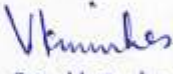
REV. NO. & DATE	DESCRIPTION OF REVISION	REVISED BY NAME & SIGNATURE	CHECKED BY NAME & SIGNATURE	REVIEWED BY NAME & SIGNATURE	APPROVED BY NAME & SIGNATURE
Rev. 1 Nov 2010	Details of the Larger size LED module added.	 Virendrakumar Wankhede EE(SC)	 C.P. Shrivastwa ACE(SC)	 A.V.Ughade ACE (RP & CI)	 30.11.2010 V.K.Minhas ACE(SC)

NPCIL PROPRIETARY

This document is the property of Nuclear Power Corporation of India Limited (NPCIL). No exploitation or transfer of any information contained herein is permitted in the absence of an agreement with NPCIL, and neither the document nor any such information may be released without the written consent of NPCIL.

NUCLEAR POWER CORPORATION OF INDIA LTD.	
TECHNICAL SPECIFICATION ON INDICATING LAMP ASSEMBLY	PAGE NO: 4 of 18 REV. NO. : 1

1.0 SCOPE

This specification covers the design, manufacture, testing, supply and guarantee of Indicating Lamp Assemblies suitable for mounting on mosaic grid structure for two units of 700MWe PHWR projects.

2.0 CONTENTS

The requirements of this specification are presented under the following section:

Description	Section
• Applicable standards and specification	3
• Materials and workmanship	4
• General Function and Description	5
• Requirements	6
• Inspection, Tests and Reports	7
• Tests	8
• Packing and Shipment	9
• Information required with the bid	10
• Single Sampling Plan	Annexure – A
• Technical Data to be furnished by the Supplier	Annexure – B
• Sample Quality Assurance Plan for Indicating lamp module	Annexure – C

3.0 APPLICABLE STANDARDS AND SPECIFICATIONS

All documents listed below constitute a part of this specification. In the event that data listed below conflict with the requirements of this specification the requirements of this specification shall govern.

3.1 Applicable Standards

- 3.1.1 IS-9000 (Part III & V) : Basic environmental testing procedure for electronic and Electrical items (Dry heat & Damp heat test).
- 3.1.2 IS-1901 : Specification of Visual Indicator Lamps
- 3.1.3 IS-4795-Part-I : Specification for holders for indicators lamps for electronic & telecommunication equipment.
- 3.1.4 IEEE-344 : Recommended practices for Seismic Qualification of Class-1E equipment for Nuclear Power Generating Stations.
- 3.1.5 MIL-105D : Military standard sampling procedures and tables for inspection by attributes.

NUCLEAR POWER CORPORATION OF INDIA LTD.	
TECHNICAL SPECIFICATION ON INDICATING LAMP ASSEMBLY	PAGE NO: 5 of 18 REV. NO. : 1

3.2 Applicable Specification

PP-E-2061 : Technical Specification for requirements of components/equipment for Instrumentation Items

4.0 MATERIALS AND WORKMANSHIP

4.1 Materials

Materials shall be of high quality industrial grade pertinent to the manufacture of indicating lamp assemblies. Components like resistors & diodes shall be MIL or JSS approved & batch certificate shall be obtained from the manufacturer.

4.2 Workmanship

The workmanship shall be in accordance with high grade commercial practice adequate to ensure satisfactory operation & service life in accordance with the provision of this specification.

5.0 GENERAL FUNCTION & DESCRIPTION

5.1 General Function

The indicating lamp assemblies are used for status indication of plant equipment like ON / OFF indication of pumps / fans, OPEN / CLOSE indication of valves etc.

5.2 General Description

The general philosophy for the instrumentation of the Nuclear Power Stations is based on the use of the instruments which are capable of continuous satisfactory operation over a period of 60 years with minimum attention.

6.0 REQUIREMENTS

The detailed requirement is as follows:

6.1 Type : Sealed LED type indicating lamp assembly with in-built current limiting resistor and series protection diode suitable for control and instrumentation purposes.

6.2 Module Dimensions : 2 nos., 3 nos., 4 nos. & 8 nos. are to be placed on 24 mm X 48mm control tile mosaic grid mountable module.

LED Dimension : 5 mm round

TECHNICAL SPECIFICATION ON INDICATING LAMP ASSEMBLY	PAGE NO: 6 of 18 REV. NO. : 1
--	----------------------------------

- 6.3 Mounting** : Suitable to flush mounting on mosaic grid based panels.
- 6.4 Material** : Body & parts shall be black anodized aluminum. Nuts shall be of Brass (TIN/Nickel plated). Washers shall be of Beryllium-Copper/Phosphor-Bronze and Tin finished Terminals shall be Brass-Silver plated or Tin-Lead plated. Sealing O-rings shall be of Silicon Rubber.
- 6.5 Connection terminal** : SUB-D-15 connector, gold plated
- Wiring** : SUB-D-15 connector, gold plated with flexible cable
- 6.6 Operating Voltage & Current** : 24V DC
 Steady state regulation : $\pm 1\%$ Set Voltage
 Transient variation : $\pm 20\%$ Set Voltage
 Ripple content in DC : $\leq 5\%$
 Typical 13 mA and max. 20 mA
- 6.7 Max. Reverse Voltage** : 200VDC.
- 6.8 Luminous Intensity at Rated voltage** : 40 mcd. However, 25 mcd for amber is acceptable.
- 6.9 Color of Glow** : RED
 GREEN
 AMBER
- a) Glow to be uniform with no shadows.
 b) Color of the lamp shall be identified on the assembly.
- 6.10 Duty** : Continuous
- 6.11 Electrical Life:** 1,00,000 hours (approx.)
- 6.12 Temperature rise of body** : Max. 25° C above ambient
- 6.13 Environment and operating conditions**

6.13.1 Normal operating conditions

Ambient temperature from 8° C to 45° C and relative humidity up to 90 %

NUCLEAR POWER CORPORATION OF INDIA LTD.	
TECHNICAL SPECIFICATION ON INDICATING LAMP ASSEMBLY	PAGE NO: 7 of 18 REV. NO. : 1

6.13.2 Occasional/Storage conditions

Ambient temperature from 5° C to 55° C and relative humidity up to 95 %

6.14 Seismic Requirement

Indicating Lamp Assembly shall be capable of indicating the information during and after seismic conditions. Seismic testing of the Indicating Lamp Assembly shall be done generally as per IEEE-344. Test frequencies and peak acceleration will be furnished later.

6.15 Insulation resistance

The insulation resistance between (a) terminals (b) terminals and housing shall be higher than 1000 MΩ at 500 VDC under specified operating conditions.

6.16 Dielectric strength

To check the integrity of the insulation HV test shall be done at 100 VAC for 1 min. and test method as per 7.3.2 of IS-4795 Part-I.

6.17 Sealing

The indicating lamp assemblies shall be subjected to this test as per clause 7.5.10 of IS-4795. The leakage rate across all seals shall not be greater than 1 CC per hour unless otherwise specified.

6.18 Mounting torque

1 Nm torque shall be applied and procedure is to be followed as per CL.7.5.7 of IS-4795.

6.19 De-rating of Components

Resistors shall be preferably metal oxide and shall not be used for more than 50% of manufacturing rating.

Semiconductor devices shall be of silicon. All semiconductors shall be adequately de-rated to prolong the life of devices and the de-rating shall be 0.7 % of normal voltage and current or 0.5 % of normal rated power.

NUCLEAR POWER CORPORATION OF INDIA LTD.	
TECHNICAL SPECIFICATION ON INDICATING LAMP ASSEMBLY	PAGE NO: 8 of 18 REV. NO. : 1

6.20 Larger size of LED indication module

One large size indicating lamp module of 96 mm (W) x 24 mm (H) shall be mounted on BCRP to show the status of “BCR in operation”.

The details of the module are:

Assembly	:	in mosaic system
Front dimensions	:	96 mm x 24 mm
Front frame	:	Grey
Components	:	18 LEDs of RED color
Connection terminal	:	SUB-D-9 connector, gold plated
Wiring	:	SUB-D-9 connector, gold plated with flexible cable/wire

For the other requirements of the module see 6.0 below

7.0 INSPECTION, TESTS AND REPORTS

7.1 General

The contractor shall be responsible for and shall perform all inspection and tests specified herein and as may further are necessary to ensure that the materials and workmanship are of the degree of excellence required by this specification and to demonstrate that the products supplied by him perform as specified herein for the approval of purchaser.

Supplier shall carry out all the tests as per quality assurance plan (QAP) enclosed herewith as Annexure-C

The purchaser or authorized representative shall have access to the contractor's premises at all reasonable times to the extent necessary to access compliance with the provisions of this specification and also to evaluate the contractor's inspection and quality control procedures.

The purchaser shall also have the right to conduct at his own expense, any additional inspection or testing deemed necessary. When tests are performed, the product shall comply with all the provisions of the specification.

7.1 Inspection

The indicating lamp assemblies shall be carefully examined to determine their conformance with this specification with respect to material, workmanship, finish, dimensions and other requirements.

NUCLEAR POWER CORPORATION OF INDIA LTD.	
TECHNICAL SPECIFICATION ON INDICATING LAMP ASSEMBLY	PAGE NO: 9 of 18 REV. NO. : 1

7.2 Reports

Certificate of compliance stating that the material is in compliance with specification and purchase order conditions shall be submitted. Five copies of the test report for all the tests carried out shall be submitted to the purchaser. All tests reports shall be signed by an authorized representative of the contractor.

8.0 TESTS

The contractor shall notify the purchaser the date and the location for the performance of the tests, giving sufficient notice to enable the purchaser or his authorized representative to be present.

The test procedure shall be proposed by the contractor and approved by the purchaser.

The purchaser or his authorized representative shall have access to the calibration certificates of the measuring equipment used for tests.

The samples required for the tests shall be selected at random by the purchaser or authorized representative and tested by the contractor.

8.1 Type Test (Test on samples)

8.1.1 Dimension

Dimensions of the indicating lamp assemblies shall be checked and shall comply with these mentioned in 6.2 of this specification.

8.1.2 Soldering

The indicating lamp assemblies shall be tested as per clause 7.5.5 of IS-4795.

8.1.3 Bump

The indicating lamp assemblies shall be tested as per clause 7.5.9 of IS-4795.

8.1.4 Seismic Test

One indicating lamp assembly shall be tested for seismic qualification as per clause 6.14 of this specification.

The indicating lamp assembly shall glow during & after seismic test.

NUCLEAR POWER CORPORATION OF INDIA LTD.	
TECHNICAL SPECIFICATION ON INDICATING LAMP ASSEMBLY	PAGE NO: 10 of 18 REV. NO. : 1

8.1.5 Climatic tests

8.1.5.1 Dry heat test

Temperature	:	$55 \pm 2^{\circ}\text{C}$
Relative Humidity	:	$< 50\%$
Standard to be followed	:	IS: 9000 PART-III/SEC-III-1977

At the end of the conditioning period of 96 hours, the Indicating lamp assembly shall be switched on and checked to see if it is functioning. It shall remain in working condition and exposed to the high temperature for two hours and tested to verify insulation resistance. Indicating lamp assembly shall then be switched off, removed from the test chamber and allowed to recover to the standard atmospheric conditions. After recovery, the Indicating lamp assembly shall again be tested as above.

8.1.5.2 Damp heat test

No of cycles	:	2 cycles of 24 hours (12 hours + 12 hours) each
Temperature Range	:	$40^{\circ} \pm 2^{\circ}\text{C}$, 90% RH to $25 \pm 5^{\circ}\text{C}$, 98% RH
Standard to be followed	:	IS: 9000 PART-V/ SEC-II-1981

The Indicating lamp assembly shall be OFF during the test. At the conclusion of the test, the Indicating lamp assembly shall be visually examined. There shall not be any visible damage or mechanical deterioration.

8.1.5.3 Cold test

Cold test shall be carried out as per IS-4795 (Part-I) - 1968 for two hours duration. The instrument shall be non-operating during the test. After the specified period of conditioning the Indicating Lamp Assembly shall be removed from the chamber and shall be examined visually. There shall be no visible damage or mechanical deterioration.

8.1.6 Temperature cycling test

This test shall be conducted for five cycles as per IS-9000(Part-14). Insulation Resistance, Voltage proof, Electrical and Physical check shall be conducted after this test.

8.1.7 Robustness of terminations

This test shall be carried out as per clause 7.5.6 of IS-4795.

NUCLEAR POWER CORPORATION OF INDIA LTD.	
TECHNICAL SPECIFICATION ON INDICATING LAMP ASSEMBLY	PAGE NO: 11 of 18 REV. NO. : 1

8.1.8 Mounting torque

Mounting torque shall be as mentioned in 6.18 of this specification.

8.1.9 Endurance test

This test shall be carried out as per clause 7.7 of IS-4795 for 168 hours at maximum temp 55°C.

8.1.10 Luminous intensity

Luminous intensity at rated voltage shall be checked.

8.1.11 Flammability

Sleeve and Diffuser material shall be as per UL-94 to meet V1 grade.

8.1.12 Salt mist test

This test shall be carried out as per clause 7.6.4 of IS-4795.

8.2 Routine tests (Tests on all Units)

8.2.1 General Examination

The indicating lamp assemblies shall be visually examined for conformity with the workmanship, finish and assembly and the same shall be satisfactory.

8.2.2 Glow check at rated voltage

Rated voltage shall be applied on indicating lamp assemblies to check the glow. Glow shall be uniform with no shadows.

8.3 Acceptance tests

Group- 'A' tests (AQL 1% the sampling procedure & acceptance criteria as MIL-105D). Please see Annexure-A at the end.

8.3.1 Group 'A' Test

8.3.1.1 Rated voltage application

Indicating lamp assemblies shall be tested for appropriate rated voltage for a period of 5 minute and there shall not be any breakdown during and after the test.

NUCLEAR POWER CORPORATION OF INDIA LTD.	
TECHNICAL SPECIFICATION ON INDICATING LAMP ASSEMBLY	PAGE NO: 12 of 18 REV. NO. : 1

8.3.1.2 Voltage proof

The indicating lamp assemblies shall be tested to verify compliance with the requirement of section 6.16.

8.3.1.3 Insulation resistance

Indicating lamp assemblies shall be tested to verify compliance with the requirement of section 6.15 of this specification.

8.3.1.4 Sealing

The indicating lamp assemblies shall be tested as to verify compliance with the requirement of section 6.17 of this specification.

8.3.1.5 Reverse voltage application test

Indicating lamp assemblies shall be tested for reverse voltage (maximum 200 VDC) and there shall not be any breakdown.

9.0 PACKING AND SHIPPING

The contractor shall make adequate provision to protect the items supplied to this specification to ensure that on arrival at the generating station or a panel fabrication shop or elsewhere as will be stated later by the purchaser and after storage as may occur, they will not have suffered corrosion or damage of any sort.

9.1 Identification during Shipment

The package (packages) shall be clearly and legibly marked in a suitably permanent manner with the following information:

Brief description of the items	:
The item no. of the purchaser	:
The purchase order no. of the purchaser	:
Number of pieces in shipment	:
Weight of the package	:

10.0 INFORMATION REQUIRED WITH THE BID

The supplier should give the technical details, delivery schedule and prices as per the format given in Annexure-B of this specification.

10.1 Delivery Period

Supplier shall supply all the indicating lamp assemblies within 3 months after placing

NUCLEAR POWER CORPORATION OF INDIA LTD.	
TECHNICAL SPECIFICATION ON INDICATING LAMP ASSEMBLY	PAGE NO: 13 of 18 REV. NO. : 1

the purchase order.

10.2 Validity

The bids shall be valid for at least 90 days.

NUCLEAR POWER CORPORATION OF INDIA LTD.	
TECHNICAL SPECIFICATION ON INDICATING LAMP ASSEMBLY	PAGE NO: 14 of 18 REV. NO. : 1

ANNEXURE-A

Single Sampling Plan for Normal Inspection (MIL-STD-105 D)

Inspection Level II : AQL:1%		
Lot of Batch size	Sample size	Rejection No.
13 to 150	13	1
151 to 500	50	2
501 to 1200	80	3
1201 to 3200	125	4
3201 to 10,000	200	6
10,001 to 35,000	315	8
35,001 to 1,50,000	500	11

NUCLEAR POWER CORPORATION OF INDIA LTD.	
TECHNICAL SPECIFICATION ON INDICATING LAMP ASSEMBLY	PAGE NO: 15 of 18 REV. NO. : 1

ANNEXURE-B

TECHNICAL DATA TO BE FURNISHED BY SUPPLIERS

1.0 Delivery & Manufacturing Schedule

Time in weeks
after receipt of order

- 1.1 Start of manufacture
- 1.2 Completion of manufacture
- 1.3 Delivery of last consignment

2.0 Technical Data

Dimensions of the indicating lamp assembly as per clause no 6.2

a) Length
b) Diameter

Type of indicating lamp assembly as per clause no. 6.1?

Yes/No

Material of Ind. lamp assembly as per clause no. 6.4?

Yes/No

Luminous intensity at rated voltage

Sealing as per clause no.6.17

Yes/No

Terminals as per clause no. 6.5

Yes/No

Color of glow as per clause no. 6.9

Yes/No

Insulation Resistance value as per clause no. 6.15

Indicating Lamp assembly can meet seismic qualification as per clause no. 6.14 ?

Yes/No

Can Supplier carryout the Acceptance Test as mentioned in the specification in the presence of Purchaser & furnish test report for the same?

Yes/No

3) Deviation from the Specification

- ◆ Any deviation in the test procedure?
- ◆ Any deviation in the items offered?

NUCLEAR POWER CORPORATION OF INDIA LTD.	
TECHNICAL SPECIFICATION ON INDICATING LAMP ASSEMBLY	PAGE NO: 16 of 18 REV. NO. : 1

4) Proof of ability

The bidder shall submit a list of similar supplies made by him as per standards and tolerance specified in this tender document.

5) Information required after award of contract.

- I) Five copies of certified test reports of the tests carried out as mentioned in clause no. 7 of this specification.
- II) Six copies of Instruction Manual with drawings.
- III) Reproducible of all drawings.

ANNEXURE-C

SAMPLE QUALITY ASSURANCE PLAN FOR INDICATING LAMP ASSEMBLY

SL. NO.	Component	Characteristics	Type of Check	Quantum of Check	Reference Document	Acceptance Norms value	Format of Record	Agency			Remarks
								P	W	V	
1	Type test	Dimension	Visual	Sample	PC-E-318	PC-E-318	Test Report	2	1	1	
		Soldering	Mechanical	Sample	IS-4795	IS-4795	--do--	2	1	1	
		Bump	Mechanical	Sample	IS-4795	IS-4795	--do--	2	1	1	
		Seismic test	Vibration	Sample	PC-E-318	PC-E-318	--do--	2	1	1	
		Climatic test	Dry heat test	Sample	IS-9000(part-III)	IS-9000(part-III)	--do--	2	1	1	
			Damp heat test	Sample	IS-9000(part-V)	IS-9000(part-V)	--do--	2	1	1	
			Cold test	Sample	IS-4795	IS-4795	--do--	2	1	1	
		Temp. cycling test	Environmental	Sample	IS-9000(part-XIV)	IS-9000(part-XIV)	--do--	2	1	1	
		Robustness of terminations	Mechanical	Sample	IS-4795	IS-4795	--do--	2	1	1	
		Mounting torque	Mechanical	Sample	IS-4795	IS-4795	--do--	2	1	1	
		Endurance test	Electrical	Sample	IS-4795	IS-4795	--do--	2	1	1	
		Luminous intensity	Electrical	Sample	PC-E-318	PC-E-318	--do--	2	1	1	
		Flammability	Electrical	Sample	PC-E-318	PC-E-318	--do--	2	1	1	
Salt mist test	Visual	Sample	IS-4795	IS-4795	--do--	2	1	1			

NUCLEAR POWER CORPORATION OF INDIA LTD.

TECHNICAL SPECIFICATION ON
INDICATING LAMP ASSEMBLY

PAGE NO: 18 of 18
REV. NO. : 1

SL. NO.	Component	Characteristics	Type of Check	Quantum of Check	Reference Document	Acceptance Norms value	Format of Record	Agency			Remarks
								P	W	V	
2	Routine test.	Visual Examination	Visual for any defects.	100%.	PC-E-318	PC-E-318	Inspection Report.	2	-	1	
		Glow check	Visual	100%	PC-E-318	PC-E-318	--do--	2	-	1	
3	Acceptance test	Rated voltage application	Electrical	sample	PC-E-318	PC-E-318	Test report	2	1	1	
		Voltage proof	Electrical	sample	PC-E-318	PC-E-318	--do--	2	1	1	
		Insulation resistance	Electrical	sample	PC-E-318	PC-E-318	--do--	2	1	1	
		Sealing	Mechanical	sample	PC-E-318	PC-E-318	--do--	2	1	1	
		Reverse voltage application	Electrical	sample	PC-E-318	PC-E-318	--do--	2	1	1	

P- Performed by
W- Witnessed by
V- Verified by

1. Purchase (NPCIL)
2. Prime Supplier
3. External Laboratory.

PREPARED BY:

M. S. Choudhary
26/11/2010

APPROVED BY:

V. Kumar
30.11.2010.

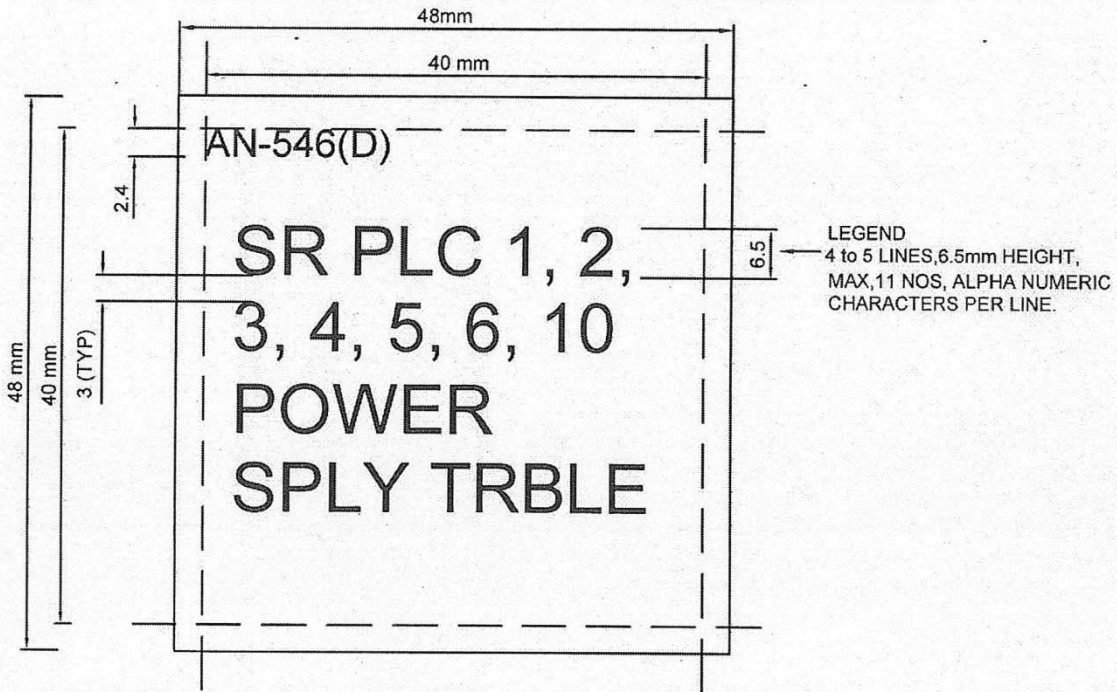

Fig.-6

TYPICAL WINDOW ENGRAVING DETAILS

(THIS FIG IS ONLY FOR GUIDANCE)

NOTES:

1. MATTER SHALL BE PHOTO FILMED, (+Ve FILM) WITH BLACK CHARACTERS CLEAR BACKGROUND FOR ALL THE LEGENDS.
2. MATTER SHALL BE CENTRALISED ALONG THE WIDTH.
3. MATTER SHALL BE LIMITED WITHIN THE SPACE SHOWN IN ALL STYLES.
4. DISPLAY AREA SHALL BE 40mm x 40mm.
5. ALL CHARACTERS SHALL BE UPRIGHT CONDENSED TYPE GENERALLY. WHEREVER THE MATTER CAN NOT BE ADJUSTED IN THE SPECIFIED SPACE. THE CHARACTERS CAN BE EXTRA CONDENSED.
6. WHEREEVER THERE ARE SPARE POSITIONS BLANK PHOTOFILM SHALL BE SUPPLIED.
7. REFER DRAWING NO. KAPP-3&4/60300/2014/SCH FOR THE DETAILS OF THE COLOUR (WHITE, RED, GREEN) FILMS.
8. THIS FIG IS NOT TO SCALE. ALL DIMENSIONS ARE IN mm.

PREPARED BY:

V. K. Kishore
12/04/2011

APPROVED BY:

V. K. Kishore
20.04.2011



NUCLEAR POWER CORPORATION OF INDIA LIMITED
(A GOVERNMENT OF INDIA ENTERPRISES)
700 MWe ATOMIC POWER PROJECT

SPECIFICATION NO:PC-E-409 REV.0

TECHNICAL SPECIFICATION

ON

TERMINAL BLOCK (POLYAMIDE) AND
ACCESSORIES FOR NON RADIATION AREA
FOR 700 MWe

REF.USI. NO.60120

REVISION NO. :	R 0			
DATE OF ISSUE : (MONTH/YEAR)	FEB.2010			
TOTAL NO. OF PAGES	26			

ORIGINAL

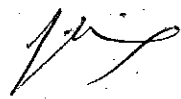
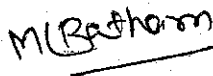
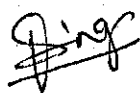
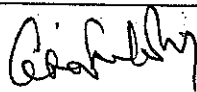
PREPARED BY	P.TILARA EXECUTIVE ENGINEER		18/02/2010
CHECKED BY	M.L. BATHAM SR. EXECUTIVE ENGINEER		18/02/2010
REVIEWED BY	V.K. SINGH ADDL. CHIEF ENGINEER		18/02/2010
APPROVED BY	A. CHAKRABORTHY SO/H (C&I)		18.02.2010.
	NAME & DESIGNATION	SIGNATURE	DATE

FILE NAME : MLB-PC-E-409 REV.0

REVISION CONTROL SHEET

DOCUMENT TYPE: TECHNICAL SPECIFICATION

NO : PC-E-409 / REV. NO. 0

**TITLE : TECHNICAL SPECIFICATION FOR
TERMINAL BLOCK (Polyamide) AND
ACCSSORIES FOR NON RADIATION
AREA FOR 700 MWe**

REV. NO. & DATE	DESCRIPTION OF REVISION	PREPARED BY	CHECKED BY	REVIEWED BY	APPROVED BY

NUCLEAR POWER CORPORATION OF INDIA LTD	
700 MWe ATOMIC POWER PROJECT TECHNICAL SPECIFICATION FOR TERMINAL BLOCK AND ACCESSORIES FOR NON RADIATION AREA	PAGE : 3 of 26 REV. NO. : 0

1.0 SCOPE:

This specification covers manufacture testing and supply of non-radiation resistant terminal blocks and their accessories for applications in non-radiation areas of 700 MWe ATOMIC POWER PROJECT.

2.0 CONTENTS

SECTION	DESCRIPTION
3.	APPLICABLE STANDARDS
4.	MATERIAL, PROCESS AND WORKMANSHIP
5.	GENERAL FUNCTIONS AND DESCRIPTION OF TERMINAL BLOCKS
6.	DESIGN REQUIREMENTS
7.	INSPECTION, TESTS AND REPORTS
8.	SHOP TESTS
9.	PACKING & DESPATCH
10.	INFORMATION REQUIRED WITH THE BID
ANNEXURE -A	TECHNICAL DATA TO BE FURNISHED BY SUPPLIERS
ANNEXURE -B	LIST OF ITEMS COVERED BY THIS SPECIFICATION
ANNEXURE -C	QUALITY ASSURANCE PLAN

NUCLEAR POWER CORPORATION OF INDIA LTD	
700 MWe ATOMIC POWER PROJECT	PAGE : 4 of 26
TECHNICAL SPECIFICATION FOR TERMINAL BLOCK AND ACCESSORIES FOR NON RADIATION AREA	REV. NO. : 0

3.0 Applicable Standards

All the standards listed below constitute a part of this specification. In the event that certain requirements of the specification or data listed below conflict with the requirements of this specification, requirements of this specification shall govern.

- 3.1 VDE 0611-1977 : Specification for terminal blocks for connecting copper conductors up to 1000 VAC and 1200 VDC.
- 3.2 VDE-0609 : Specification for clamp of screw terminals for Connection of copper conductors up to 240 mm².
- 3.3 IS- 9000 : Basic Environmental testing procedures for Electronic and electrical items.
- 3.4 IS-4007 : Specification for terminals for electronic Equipments.
- 3.5 IEEE-344-1987 : IEEE-Recommended practices for Seismic Qualification of Class 1E Equipment for Nuclear Power Generating Stations.
- 3.6 BS-1224-1965 : Specification for electroplated coating of Nickel and chromium.
- 3.7 UII.-94 : Test for Flammability of plastic materials.
- 3.8 IS-2500(Part-1)-1992 : Sampling inspection procedure Part-1 Attributes Sampling plans indexed by acceptable quality Level (AQL) for Lot by not inspection.

4.0 MATERIALS, PROCESS AND WORKMANSHIP

4.1 Material and Processes :

Material, Processes and standard parts which are not specifically described herein and which are necessary to meet this specification shall be of first class quality and in accordance with good practice pertinent to manufacture of electrical control components.

NUCLEAR POWER CORPORATION OF INDIA LTD	
700 MWe ATOMIC POWER PROJECT	PAGE : 5 of 26
TECHNICAL SPECIFICATION FOR TERMINAL BLOCK AND ACCESSORIES FOR NON RADIATION AREA	REV. NO. : 0

4.2 Workmanship :

Workmanship shall be in accordance with high-grade industrial practice and shall be adequate to ensure service life of 40 years.

4.3 Tropicalisation:

The design, material used, manufacturing and assembly shall be done to render the parts and assembled equipment moisture, fungus, micro-organism & termite resistant. Proper surface treatment of the moisture and fungus susceptible parts of the component and their assembly shall be done. Care shall be taken during treatment to avoid its effect on the performance of the components and its assembly.

5.0 General Functions and Description of Terminal Blocks.

Basically the terminal block is a component, which interconnects two wires and serves as a junction point. The interconnection may be done by means of clamping screw or by means of soldering. An individual terminal block consists of conductor clamping assembly/solder lugs mounted on an insulating casing. All the terminal blocks covered by this specification shall be of individual snap-on-type, narrow width blocks, which can be stacked on a mounting channel or bar. Each terminal block shall have one side open and the other insulated side. When stacked on the mounting bar, the terminal blocks shall be automatically insulated against each other by their insulated sides. An End plate is required to seal and insulate the open end of the unit, so that the complete unit of terminal blocks shall remain fixed in its position on the mounting bar. Wherever necessary cross connection of adjacent terminals are achieved by cross connectors, after removing the knockouts provided on the insulating casing. These cross connectors are screwed to the conductor clamping assembly by means of screws specifically provided for the purpose.

6.0 DESIGN REQUIREMENTS

The micro or miniature terminal blocks shall be manufactured generally in accordance with VDE 0611/IS-4007 standard. They shall be tested in accordance with the relevant IS and VDE standards for the various parameters listed in this specification.

NUCLEAR POWER CORPORATION OF INDIA LTD	
700 MWe ATOMIC POWER PROJECT	PAGE : 6 of 26
TECHNICAL SPECIFICATION FOR TERMINAL BLOCK AND ACCESSORIES FOR NON RADIATION AREA	REV. NO. : 0

6.1 Operating Conditions

Terminal blocks and accessories covered by this specification shall be suitable for continuous and reliable operation in an ambient temperature range of 8^oC to 55^oC and relative humidity range of 2% to 100% and maximum conductor temperature of 100^oC. In addition, they shall be manufactured and tested for reliable service under the following occasional operating conditions and storage conditions.

1. Ambient temperature range: 8^oC to 55^oC
2. Relative Humidity range: 2% to 100%

6.2 Terminal Blocks with Screw Connections

Item 1, 4 and 5 of Annexure-B of this specification are terminal block with Screw connection. The terminal block shall be side entry type for conductors. It shall have conductor-clamping assembly mounted on an insulating casing. Conductor clamping assembly is described here whereas insulating casing, end plate and end clamp are described in Clause 6.4 of this specification. Conductor clamping assembly shall be provided with two self-locking pressure screws, one at each end, to facilitate clamping of incoming conductors/wires. They shall be made of Brass plated with minimum 5-micron thickness of Nickel.

Conductor clamping assembly should be recessed well in the insulating casing, below the surface of the terminal blocks to prevent the possibility of accident by touching the current carrying parts. The conductor clamping assembly shall be provided with two screws one at each end to clamp the conductors. The same screws shall hold the conductor clamping assembly, in the insulating casing. The screws shall have at least two full threads tightly engaging the threaded holes in the insulating casing. Protective pads shall be provided at the bottom of these screws so as to prevent conductor damage and the screws shall be captive in the protecting pads. The clamping assembly shall be provided with a hole at the center for connecting cross connectors. The terminal blocks shall be supplied with conductor clamping screws kept in fully open condition. The screws shall be capable of withstanding 50 screwing operation (loosening & tightening) at recommended torque. Conductor clamping assembly and clamping screws shall be of Brass plated with minimum 5-micron thickness of Nickel. Screw dimensions and tightening torques are as per VDE 0609 and VDE 0611. The current bar shall be Brass plates with minimum 5 microns thickness of Tin. The specification BS : 1224-1965 shall apply for electroplated coating of Nickel and Chromium.

NUCLEAR POWER CORPORATION OF INDIA LTD	
700 MWe ATOMIC POWER PROJECT	PAGE : 7 of 26
TECHNICAL SPECIFICATION FOR TERMINAL BLOCK AND ACCESSORIES FOR NON RADIATION AREA	REV. NO. : 0

6.3 Terminal Blocks with Double Solder Connections.

Items 2 & 3 of Annexure-B of this specification are solder type terminal blocks. An individual terminal block of this type shall be of individual snap on type consisting of solder lugs mounted on an insulating casing. Projecting solder lugs should be in Zig Zag layout to improve accessibility and to increase the mutual insulation resistance. Solder lugs shall be provided with a threaded hole at the centre for connecting cross connections. Solder lugs shall be plated with tin/lead with a minimum thickness of 5 microns. The solder ends of the current bar shall have a hole, which can easily accommodate conductor of size up to 1.5mm².

6.4 Insulating Casing, End Plate and End Clamp

Insulating casing, end plate and end clamp shall be light, non-inflammable self extinguishing material, high creepage, shockproof, and withstand tropical temperature variations and climatic condition. Colour of the insulating casing, end plate and end clamp shall be gray. A creepage groove located below the conductor clamping assembly shall be moulded up on each side of the insulating casing to increase and maintain the creepage distance between the conductor clamping assembly and mounting bar.

Knockout shall be provided at the top of the insulating casing to allow mounting of cross connectors. These knockouts shall be such that they can easily be removed by means of pliers or other suitable tool. This tool shall be supplied by the supplier along with cross connectors. Two identical slots, one at each edge, suitable for inserting marking tags shall be provided on the insulating casing. Slots shall be in such a position that when the terminal block is mounted, it can be identified easily. Further the slot shall be such that the tags can be inserted after assembling the terminal blocks units.

Insulating material for casing, end plates and end clamps shall be of Polyamide 6.6 and it shall be capable of withstanding maximum continuous temperature of 100°C.

6.5 Cross Connectors.

Cross Connectors and their screws shall be of brass plate with a minimum 5 micron thickness of nickel or tin/lead. Cross connectors are required in lengths suitable for use unto six connectors.

NUCLEAR POWER CORPORATION OF INDIA LTD	
700 MWe ATOMIC POWER PROJECT TECHNICAL SPECIFICATION FOR TERMINAL BLOCK AND ACCESSORIES FOR NON RADIATION AREA	PAGE : 8 of 26 REV. NO. : 0

6.6 Marking Tags

Each terminal block will be identified by these markings or identifying tags inserted in appropriate slots provided on the insulating casing.

They shall withstand climatic and temperature variations without any noticeable change in properties. They shall be suitable for easy insertion into slots after assembling the terminal blocks unit. They are required in three forms as follows:

- (a) In white colour with black lettering.
- (b) In white colour without lettering.
- (c) In green colour with black lettering.

The lettering shall have very good adhesion. Suitable marker pens and other accessories such as ink should be supplied for marking on unlettered marked tags.

6.7 Mounting Accessories

The mounting channel or bar shall be suitable structural steel capable of withstanding the operating conditions listed in Clause 6.1 of this specification. Rough edges and burrs are removed at all places. The end clamp material shall be same as insulating casing. The end clamping screws shall be of self locking type to avoid accidental breaks due to vibration. The mounting bar shall be provided with slots of uniform size at 11 mm intervals. Mounting channels shall be coated with zinc and chromate passivated. The coating thickness shall be 5 microns minimum.

Design of mounting rails shall conform to standard DIN-EN-50035. They shall be supplied in standard length of 1 meter each.

6.8 Technical Requirements

6.8.1 Electrical

- a) Voltage rating;
 - 1) 600 V for 4 mm² Screw type Terminal Blocks.
 - 2) 250 V for 1.5 mm² Solder type Terminal Blocks.
 - 3) 750 V for 10 mm² and 35 mm² screw type Terminal Blocks.
- b) Current rating :
 - 1) 25A maximum for screw type terminals of 4 mm²
 - 2) 57 A maximum for screw type terminals of 10 mm²
 - 3) 125 A maximum for screw type terminals of 35 mm²
 - 4) 8A maximum for solder type terminals.

NUCLEAR POWER CORPORATION OF INDIA LTD	
700 MWe ATOMIC POWER PROJECT TECHNICAL SPECIFICATION FOR TERMINAL BLOCK AND ACCESSORIES FOR NON RADIATION AREA	PAGE : 9 of 26 REV. NO. : 0

- c) Screw type terminals suitable for clamping conductors of sizes in range – 0.5 to 4.0 mm² for 4 mm² terminal block, 1.5 mm² to 10 mm² for 10 mm² terminal block and 10 mm² to 35 mm² for 35 mm² terminal block.
- d) Solder type terminals suitable for conductors of size max. 1.5 mm²
- e) Insulation resistance with testing potential of 500V DC. (As per VDE 0303).
- i) Between adjacent terminals : 1000 X 10⁹ Ω minimum
- ii) Between the terminal and : 1000 10⁹ Ω minimum
- f) Voltage drop : 3 millivolts maximum (as per VDE 0611, Clause 3.2.2.8)
(Contract resistance)
- g) Capacitance between adjacent: 50pf (max.)
Terminals
- h) Capacitance between terminal: 50 pf(max.)
& mounting rail.
- i) High voltage test : Screw type TB: 3KVRMS.
(As per VDE 0611,
Clause 3.2.2.7)
Solder type TB: 2KVRMS.
(as per VDE 0611, clause 3.2.2.7)

6.8.2 Dimensional Requirements

The maximum dimension of the terminal blocks shall be as given below.
(Dimension in mm)

4mm² TB (screw type) : 27 W X 29 H X 6.5T

1.5 mm² TB(Solder type) : 52W X 29 H X 6T
(width includes lengths of extended current bar and solder lugs at both sides)

10 mm² TB (Screw Type) : 43W X 47H X 10T

35 mm² TB (Screw Type) : 52.5W X 58H X 15T

NUCLEAR POWER CORPORATION OF INDIA LTD	
700 MWe ATOMIC POWER PROJECT TECHNICAL SPECIFICATION FOR TERMINAL BLOCK AND ACCESSORIES FOR NON RADIATION AREA	PAGE : 10 of 26 REV. NO. : 0

6.8.3 Identification Requirements

Each individual terminal block and accessories shall be indented with type number and other details so that these can be easily identified and related to items covered in Annexure-B of this specification.

7.0 INSPECTION, TESTS AND REPORTS

Quality surveillance relating to all aspects of manufacture shall be carried out by NPCIL, Mumbai. The supplier shall provide all the testing and inspection services and facilities satisfactorily as required. Inspection shall be carried out in a satisfactory manner and shall be subjected to approval by the purchaser. The supplier shall prepare inspection plan in line with QAP enclosed with tender document and submit to purchaser for approval.

Five copies of test reports and certificate of compliance stating the material is in accordance with the requirements specified in the specification shall be furnished by the supplier.

8.0 SHOP TESTS

8.1 Type tests

Following type tests shall be conducted generally as per sequence given in IS:4007 (Part-1)- 1967.

8.1.1 Voltage drop (contact resistance) test as per VDE 0611, part 1, Clause 3.2.2.8

8.1.2 Insulation resistance test as per VDE 0303, part 3 between adjacent terminals of an assembled unit and between terminal blocks and mounting bar.

8.1.3 High voltage test as per VDE 0611, part -1, clause 3.2.2.7

8.1.4 Capacitance between adjacent terminals and between terminal and mounting rails at test voltage of 240 VAC 50 Hz.

8.1.5 Salt Mist Spray Test

This test shall be conducted as per IS-9000 (Part-11) for 4 days. There should be no corrosion or other mechanical deterioration.

NUCLEAR POWER CORPORATION OF INDIA LTD	
700 MWe ATOMIC POWER PROJECT TECHNICAL SPECIFICATION FOR TERMINAL BLOCK AND ACCESSORIES FOR NON RADIATION AREA	PAGE : 11 of 26 REV. NO. : 0

8.1.6 Fire Retardant Test

Casing shall be tested as per UL-94 and shall have the grade V0.

8.1.7 Tensile Test

It shall be carried out in accordance to VDE 0611, Part 1, Clause 3.2.2.3 to check for the required conductor pullout strength.

8.1.8 Tight-fit-test

It shall be carried out in accordance to VDE 0611, Part 1, clause 3.2.2.4. No terminal shall become detached or significantly change its position, when it is slowly loaded away from the mounting plane with the specified force.

8.1.9 Mechanical Endurance Test (For Screw type TB):

Terminal screws shall be tightened and loosened 50 times. Conductor of rated cross-section shall be used and related torque shall be applied.

During the test no damage impairing further use of screwed connections shall occur.

After the test voltage drop test as per Clause 3.2.2.8 of VDE 0611 shall be conducted. The voltage drop shall not exceed 3 mV.

8.1.10 Torque Test (For screw type TB)

This test shall be conducted at rated torque as per clause 3.2.2.1 of VDE 0611 Part-1.

8.1.11 Heating Test :

This test shall be conducted as per 3.2.2.5 of VDE 0611 Part-I for rated conductor cross section and at rated current.

Temperature rise of contact at measuring points shall not exceed 45⁰ C.

Voltage drop test, High voltage test and Insulation resistance test shall be conducted after heating test.

NUCLEAR POWER CORPORATION OF INDIA LTD	
700 MWe ATOMIC POWER PROJECT	PAGE : 12 of 26
TECHNICAL SPECIFICATION FOR TERMINAL BLOCK AND ACCESSORIES FOR NON RADIATION AREA	REV. NO. : 0

8.1.12 Testing that the inscriptions resist wiping

This test shall be conducted as per clause 3.2.2.11 of VDE 0611 Part-I. This inscriptions shall be rubbed for 15 seconds with a rag dipped in water and then dipped in petrol.

Inscriptions shall be visible after the test.

8.1.13 Thickness of plating:

In addition to the above tests, the plated components shall be checked for coating thickness by measuring the same by any of the following methods.

- i) Microscope method
- ii) Coulometric method
- iii) Beta Back Scatter method
- iv) BNF Jet test

8.1.14 Dimension checks of terminal blocks and accessories

The dimension of the terminal blocks shall not exceed the dimensions given in clause 6.8.2 and the accessories shall be suitable for the dimensions of the terminal blocks.

8.1.15 Thermal aging

This test shall be conducted in an oven with natural air circulation at a temperature of $110^{\circ} \text{C} \pm 5^{\circ} \text{C}$ for 7 days as per VDE 0611. After the thermal ageing test, insulation resistance test, high voltage test & voltage drop test shall be conducted again.

8.1.16 Climatic test:

8.1.16.1 Dry Heat Test:

Dry heat test shall be conducted at 55°C , 50% RH for 4 hours duration as per IS-9000 (Part-3) Sec.2.

After Tests:

- (a) There shall be no damage to insulating casing and no corrosion or other mechanical deterioration to other parts.

NUCLEAR POWER CORPORATION OF INDIA LTD	
700 MWe ATOMIC POWER PROJECT	PAGE : 13 of 26
TECHNICAL SPECIFICATION FOR TERMINAL BLOCK AND ACCESSORIES FOR NON RADIATION AREA	REV. NO. : 0

- (b) Voltage drop test shall be conducted as per VDE 0611, Part-1. The value of voltage drop shall not exceed 5 mV.
- (c) Insulation resistance test shall be conducted as per VDE 0303 Part-3. The value of insulation resistance shall not be less than 10^8 ohms.
- (d) High voltage test shall be conducted as per VDE 0611, Part-1. There shall be no flash over and break down..

8.1.16.2 Damp heat test (Cyclic):

Damp heat cyclic test shall be conducted as per IS-9000 Part-5, Sec.2.

Test must be conducted at the conditions mentioned below:

Upper temperature and humidity : 40°C , 90% RH

Lower temperature : 32°C , 95% RH

Each cycle is of 12 hours + 12 hours duration.

Number of Cycles : 2

After Tests

- (a) There shall be no damage to insulating casing and no corrosion or other mechanical deterioration to other parts.
- (b) Voltage drop test, Insulation resistance test and high voltage test shall be conducted. Acceptance criteria is as per 8.1.16.1(b), (c) & (d) respectively.

8.1.16.3 Damp Heat (Steady State) Test:

Damp heat (steady state) shall be conducted at $40^{\circ}\text{C} \pm 2^{\circ}\text{C}$, $93 \pm 2\%$ RH for 21 days as per IS-9000 (Part-4).

- After test :
- (a) There should be no corrosion or other mechanical deterioration.
 - (b) Voltage drop test, insulation resistance test and high voltage test shall be conducted Acceptances criteria is as per 8.1.16.1(b), (c) & (d) respectively.

NUCLEAR POWER CORPORATION OF INDIA LTD	
700 MWe ATOMIC POWER PROJECT TECHNICAL SPECIFICATION FOR TERMINAL BLOCK AND ACCESSORIES FOR NON RADIATION AREA	PAGE : 14 of 26 REV. NO. : 0

8.1.17 **Seismic Testing :**

Seismic testing of the terminal block shall be done generally as per IEEE-344 and the details given below:

- (a) Type of motion : Sinusoidal
- (b) Test frequencies : Terminal blocks shall be tested at Frequencies spaced at an interval of 1/3rd Octave starting from 1Hz to 33 Hz.
- (c) Peak acceleration : 3.5 g in horizontal axis and 3.5g in Vertical axis.
- (d) Test duration : Tests to be conducted separately for Each of the three axes for 30 seconds at each of the test frequencies.
- (e) Environmental : Tests shall be conducted under Ambient conditions which fall within The normal operating condition listed in para 6.1 of this specification.

(f) **Details of mounting :**

50 nos. of terminal blocks shall be stacked on the mounting rail & securely clamped. Mounted rail should be supported at both ends with no intermediate support in horizontal direction and seismic test carried out.

For testing in the vertical direction, 50 nos. of terminal blocks shall be stacked on the mounting rail and mounting rail mounted vertically with two supports at both ends and seismic test carried out.

(g) **Pre-Vibration Tests :**

Visual inspection shall be carried out for any physical damage of loose parts.

Contact resistance shall be measured. Wires of at least 4 different sizes shall be used, in range 60.5 to 4 mm² for items-1,2 & 3 of Annex-B, 1.5mm² to 10mm² for item no.4 of Annex-B and 10mm² to 35 mm² for item no.5 of Annex-B. Torque setting should be as per clause 3.2.2.1 of VDE 0611, Part-1.

NUCLEAR POWER CORPORATION OF INDIA LTD	
700 MWe ATOMIC POWER PROJECT	PAGE : 15 of 26
TECHNICAL SPECIFICATION FOR TERMINAL BLOCK AND ACCESSORIES FOR NON RADIATION AREA	REV. NO. : 0

(h) **Tests to be conducted during vibration.**

A current of 1 A shall be flown through the terminal blocks and observe continuity.

(i) **Post Seismic Test.**

Visual inspection shall be conducted to detect any physical damage or loosening of parts.

Voltage drop shall be measured and torque setting checked.

(j) **Acceptance Criteria.**

(A) There should not be any damage or loosening of parts.

(B) Voltage drop should be within specified limits.

(C) Electrical circuit should not be interrupted.

8.2 **Acceptance Tests.**

Following inspection/acceptance tests shall be carried out on terminal block samples taken from a lot. Total no. of terminal blocks of one type shall be treated as lot size. The samples size for acceptance tests shall be as per general inspection level II of IS-2500 (Part-1): 1992. The sampling plan followed shall be double sampling plan. The value of AQL (Acceptance quality levels) shall be 1.0 and acceptance no. shall be selected as per table-III A of IS-2500 (Part-1) : 1992.

8.2.1 **Visual Inspection.**

Visual inspection shall be done on all the components of terminal block assembly and accessories:

The terminal block shall be free from :

- Cracks and empty pockets or air bubbles in the insulating casing.
- Surface irregularities on insulating casing.
- Visual defects in conductor clamping assembly.

NUCLEAR POWER CORPORATION OF INDIA LTD	
700 MWe ATOMIC POWER PROJECT	PAGE : 16 of 26
TECHNICAL SPECIFICATION FOR TERMINAL BLOCK AND ACCESSORIES FOR NON RADIATION AREA	REV. NO. : 0

The mounting rails shall be free from :

- Sharp edges and burrs on the surface.
- Missed plating
- Irregular bends and sags.

8.2.2 Tests.

- Voltage drop test as per VDE 0611
- Insulation resistance as per VDE 0303
- High voltage test as per VDE 0611
- Capacitance between terminals as per clause no.8.1.4 of this specification.
- Fire retardant test as per UL-94-VO
- Dimension check as per clause no.8.1.14 of this specification
- Thickness of plating as per clause no.8.1.13 of this specification.

9.0 PACKING AND DESPATCH.

The terminal blocks shall be so packed as not to suffer deterioration, damage or breakage during shipment. Packing should be such that the ingress of moisture, dirt and other foreign material can be avoided. Packing method shall be adequate to withstand a period in transit for more than two months and storage at site under a tropical climate for minimum period of one year without suffering any damage or deterioration. Each package shall be properly labeled to indicate the type and quantity of material it contains, purchase order number, dimensions, weight and any other necessary data to identify the equipment and relate it to the contract.

Contractor shall not ship the material without the prior approval of the purchaser or his authorized representative and subsequent instruction to do so.

Complete instruction relating to shipping and documentation will be furnished with the PO.

10.0 INFORMATION REQUIRED WITH THE BID.

The supplier should give the delivery schedule, technical details and prices as per the format given in Annexure-A and Annexure-B of this specification respectively.

NUCLEAR POWER CORPORATION OF INDIA LTD	
700 MWe ATOMIC POWER PROJECT	PAGE : 17 of 26
TECHNICAL SPECIFICATION FOR TERMINAL BLOCK AND ACCESSORIES FOR NON RADIATION AREA	REV. NO. : 0

10.1 **DELIVERY PERIOD.**

Supplier shall supply the terminal blocks and accessories within 9 months after placing the purchase order.

10.2 **VALIDITY.**

The supplier's offer shall be valid for at least 120 days.

NUCLEAR POWER CORPORATION OF INDIA LTD	
700 MWe ATOMIC POWER PROJECT TECHNICAL SPECIFICATION FOR TERMINAL BLOCK AND ACCESSORIES FOR NON RADIATION AREA	PAGE : 18 of 26 REV. NO. : 0

ANNEXURE-A.

Technical Data to be furnished by Suppliers

(1) Delivery & Manufacturing Schedule.

Time in weeks after
Receipt of order

- (a) Start manufacture
- (b) Complete manufacture
- (c) Delivery of last consignment
- (2) Technical Data for items 1,2,3, 4 & 5 of Annexure-B.
 - (a) Dimensions of individual terminal blocks
 - (b) Stacking capacity/meter length
 - (c) Conductor clamping assembly material, coating material and thickness of coating.
 - (d) Pressure screw material & coating material and thickness of coating on pressure screws.
 - (e) Material for solder lug, coating material, thickness of coating on solder lug, size of hole at solder ends of the current bar.
 - (f) Whether solder lugs of solder type terminals suitable for zig zag arrangement Yes/No.
 - (g) Recommended torque setting for each type of the terminal blocks.
 - (h) Whether cross connectors for upto 6 cross connectors provided Yes/No.

NUCLEAR POWER CORPORATION OF INDIA LTD	
700 MWe ATOMIC POWER PROJECT TECHNICAL SPECIFICATION FOR TERMINAL BLOCK AND ACCESSORIES FOR NON RADIATION AREA	PAGE : 19 of 26 REV. NO. : 0

- (i) Material for current bar, coating material and thickness of coating on current bar
- (j) Insulating materials for casing, end plates and end clamps of screw type terminal and their colour.
- (k) Insulating material for casing, end plates and end clamps of solder type terminals and their colour.
- (l) Insulation resistance value (Ref. Clause 6.8.1)
- (m) Voltage drop value (Ref. Clause -6.8.1)
- (n) Capacitance value between adjacent terminals and between terminal & mounting rail. (Ref. Clause 6.8.1)
- (o) Are the insulating casing of the terminal blocks fire retardant as per UL-94-VO Yes/No.
- (p) Whether supplier can carry out all the acceptance tests listed in this specification in presence of purchaser and furnish test reports for the same. Yes/No.
- (q) Whether the supplier can furnish test reports for all type test listed in this specification Yes/No.
- (r) Whether it is possible to supply marking tags in various colour combinations listed in clause 6.6. Yes/No.
- (s) Type of mounting channel for 4mm² & 1.5mm² TB
- (t) Type of mounting channel for 10mm² TB & 35mm² TB
- (u) Mounting channel material, coating material and coating thickness.

NUCLEAR POWER CORPORATION OF INDIA LTD	
700 MWe ATOMIC POWER PROJECT TECHNICAL SPECIFICATION FOR TERMINAL BLOCK AND ACCESSORIES FOR NON RADIATION AREA	PAGE : 20 of 26 REV. NO. : 0

(3) **Deviations from Specifications.**

- Any deviations in test procedure from the specification
- Any deviation in items offered

(4) **Proof of ability**

The bidder shall submit a list of similar supplies made by him to standards and tolerance specified in this tender document.

(5) Information required after award of contract

1. Five (5) copies of certified test reports for the tests mentioned in clause 8.1 of this tender.
2. Six copies of instruction manual with drawings.
3. Reproducible of all drawings.

NUCLEAR POWER CORPORATION OF INDIA LTD	
700 MWe ATOMIC POWER PROJECT TECHNICAL SPECIFICATION FOR TERMINAL BLOCK AND ACCESSORIES FOR NON RADIATION AREA	PAGE : 21 of 26 REV. NO. : 0

Annexure-B

List of items covered by this Specification

The following list covers the different types of terminal blocks and their accessories for two units.

Item No.	Description	Qty	Unit Price	Total Price
1.	Terminal Blocks with Polyamide 6.6 insulating material snap - on type with screw connections, rated for 600V, 25 A capable of accepting copper conductor, stranded or solid, of cross sections 0.5 to 4 mm ²	250000 nos.		
2.	Terminal block with Polyamide 6.6 insulating material snap on type with double solder connection rated for 250V, 8A suitable for max. Conductor sizes of 1.5mm ² , left solder lug above and right solder lug below.	18000 nos.		
3.	Same as item-2 but with right solder lug above and left solder lug below.	18000 nos.		
4.	Same as item-1 but suitable for conductor size of 1.5mm ² to 10mm ² and rated for 750V, 57A	3000 nos.		
5.	Same as item-1 but suitable for conductor size of 10mm ² to 35 mm ² and rated for 750V, 125A	300 nos.		
6.	End Plates			
6.1	End plates for Item 1	6750 nos.		
6.2	End plates for Item 2 & 3	1150 nos.		
6.3	End plates for item 4	300 nos.		
6.4	End plates for item 5	50 nos.		
7.	End Clamps			
7.1	End clamps for item 1	13500 nos.		
7.2	End clamps for item 2 & 3	2250 nos.		
7.3	End clamps for item 4	720 nos.		
7.4	End clamp for item 5	100 nos.		
8.	Mounting Channel			

NUCLEAR POWER CORPORATION OF INDIA LTD	
700 MWe ATOMIC POWER PROJECT	PAGE : 22 of 26
TECHNICAL SPECIFICATION FOR TERMINAL BLOCK AND ACCESSORIES FOR NON RADIATION AREA	REV. NO. : 0

8.1	Mounting channel in standard Length of 1 meter for item 1	3000 Nos.		
8.2	Mounting channel in standard length of 1 meter for item 2 & 3	550 Nos.		
8.3	Mounting channel in standard Length of 1 meter for item-4.	100 Nos.		
8.4	Mounting channel in standard Length of 1 meter for item-5	12 Nos.		
9.	Marking Tags			
9.1	Marking tags in white colour with Black lettering suitable for items 1,2,3,4 & 5 in the following			
9.1.1	1 to 30 set for item 1,2,3,4 &5	1450 nos.		
9.1.2	1 to 50 set for item 1,2, & 3 only	3150 nos.		
9.1.3	51 to 100 set for item 1,2 & 3 only	540 nos.		
9.1.4	101 to 200 set for item 1,2 & 3 only	180 nos.		
9.2	Marking tags in green colour with black lettering to items 1,2,3 in the following sets.			
9.2.1	1 to 5 set	180 nos.		
9.2.2	21 to 50 set	180 nos.		
9.2.3	51 to 60 set	90 nos.		
9.2.4	101 to 110 set	145 nos.		
9.2.5	210 to 220 set	90 nos.		
9.3	Unlettered marking tags white Suitable for marking from 1 to200	90 Sets for item-1 18 sets for item-2 &3 12 sets for item-4 and 5		
10	Cross connectors suitable for 6 connectors			
10.1	Suitable for item 1	4050 nos.		
10.2	Suitable for item 2 & 3	810 nos.		
10.3	Suitable for item 4	90 nos.		
10.4	Suitable for item 5	12 nos.		
11.0	Knockout tools	30 nos.		
12.0	Cost of type test except seismic test			
13.0	(a) Cost of seismic test (b) Handling charges for seismic test			

NOTE: Seismic test may be conducted at ECIL, Hyderabad or at IIT Mumbai, etc.

ANNEXURE-C

QUALITY ASSURANCE PLAN FOR TERMINAL BLOCK & ACCESSORIES FOR NON RADIATION AREA

Sl. No	Components	Characteristics	TYPE OF CHECK	QUANTUM OF CHECK	REFERENCE DOCUMENT	ACCEPTANCE NORMS/VALUE	FORMAT OF REPORT	AGENCY			REMARKS
								P	W	V	
1	Finished Product	Physical	Dimension Check (Type test)	IS-4007 (Part-1) 1967	NPCL Spec.	NPCL Spec	Test Report	2 or 3	1	1	
		Electrical	Voltage drop (Type test)	-do-	VDE 0511, Part-1, clause 3.2.2.8	VDE 0611	--do-	2 or 3	1	1	
		-do-	Insulation Resistance test (Type test)	-do-	VDE 0303 Part-3	NPCLL Spec.	-do-	2 or 3	1	1	
		4.0 -do-	High Voltage Test (Type test)	-do-	VDE 0611 Part-1, Clause 3.2.2.7	VDE 0611 Part 1 Clause 3.2.2.7	-do-	2 or 3	1	1	
		5.0 -do-	Capacitance (Type test)	-do-	NPCL Spec.	NPCL Spec.	-do-	2 or 3	1	1	
		6.0 Corrosion Resistance	Salt mist spray Test (Type test)	-do-	IS-9030 (Part-11)	NPCL Spec.	-do-	2 or 3	1	1	
		7.0 -do-	Thickness of Plating (Type test)	-do-	NPCL Spec	NPCL Spec.	-do-	2 or 3	1	1	
		8.0 Fire withstand	Fire retardant test (Type test)	-do-	UL-94	NPCL Spec.	-do-	2 or 3	1	1	

ANNEXURE-C

QUALITY ASSURANCE PLAN FOR TERMINAL BLOCK & ACCESSORIES FOR NON RADIATION AREA

Sl. No	Components	Characteristics	TYPE OF CHECK	QUANTUM OF CHECK	REFERENCE DOCUMENT	ACCEPTANCE NORMS/VALUE	FORMAT OF REPORT	AGENCY			REMARKS
								P	W	V	
9.0	Finished Product	Mechanical	Tensile test (Type test)	IS-4007 (Part-1) 1967	VDE 0611 Part-1, Clause 3.2.2.3	VDE 0611 Clause 3.2.2.3	Test Report	2 or 3	1	1	
10.0		Electrical	Voltage drop (Type test)	-do-	VDE 0611, Part-1, clause 3.2.2.4	VDE 0611, Part-1, clause 3.2.2.4	--do-	2 or 3	1	1	
11.0		-do-	Mechanical Endurance test (Type test)	-do-	NPCL Spec.	NPCL Spec.	-do-	2 or 3	1	1	
12.0		-do-	Torque (Type test)	-do-	VDE 0611 Part-1, Clause 3.2.2.1	VDE 0611 Part 1 Clause 3.2.2.1	-do-	2 or 3	1	1	
13.0		Thermal	Heating test (Type test)	-do-	VDE 0611, Part-1, Clause 3.2.2.5	VDE 0611, Part-1, Clause 3.2.2.5	-do-	2 or 3	1	1	
14.0		-do-	Thermal aging Test (Type test)	-do-	VDE 0611, Part-1, Clause 3.2.2.9	VDE 0611 Part-1, Clause 3.2.2.9	-do-	2 or 3	1	1	

NUCLEAR POWER CORPORATION OF INDIA LTD
700 MWe ATOMIC POWER PROJECT
TECHNICAL SPECIFICATION FOR TERMINAL BLOCK AND ACCESSORIES FOR
NON RADIATION AREA

PAGE : 25 of 26
 REV. NO. : 0

ANNEXURE-C

QUALITY ASSURANCE PLAN FOR TERMINAL BLOCK & ACCESSORIES FOR NON RADIATION AREA

Sl. No	Components	Characteristics	TYPE OF CHECK	QUANTUM OF CHECK	REFERENCE DOCUMENT	ACCEPTANCE NORMS/VALUE	FORMAT OF REPORT	AGENCY			REMARKS
								P	W	V	
15.0	Finished Product	Environment Withstand	Dry Heat test (Type test)	IS-4007 (Part-1) 1967	IS-9000 (Part-3)	NPCL Spec.	Test Report	2 or 3	1	1	
16.0		-do-	Damp heat (cyclic) test (Type test)	-do-	IS-9000 (Part-5)	-do-	--do-	2 or 3	1	1	
17.0		-do-	Damp heat (steady state) test (type test)	-do-	IS-9000 (Part-4)	-do-	-do-	2 or 3	1	1	
18.0		-do-	Inscriptions Wiping test (Type test)	-do-	VDE 0611 Part-1, Clause 3.2.2.11	VDE 0611 Part 1 Clause 3.2.2.11	-do-	2 or 3	1	1	
19.0		Seismic Withstand	Seismic Test (Type test)	50 nos. For Each type	IEEE-344 & NPCL Spec.	NPCL Spec.	-do-	2 or 3	1		
20.0		Visual Examination	Visual for any Visible defects (Acceptance test)	IS-2500 (Part-1) 1992	NPCL Spec.	NPCL Spec.	Inspection report	2	1	1	
21.0		Electrical	Voltage drop Test (Acceptance test)	-do-	VDE 0611 Part-1, Clause 3.2.2.8	VDE 0611 Part-1	Test Report	2	1	1	

60120/PC-E-409

FEB 2010

ANNEXURE-C

QUALITY ASSURANCE PLAN FOR TERMINAL BLOCK & ACCESSORIES FOR NON RADIATION AREA

Sl. No	Components	Characteristics	TYPE OF CHECK	QUANTU M OF CHECK	REFERENCE DOCUMENT	ACCEPTANCE NORMS/VALUE	FORMAT OF REPORT	AGENCY			REMARKS
								P	W	V	
22.0	Finished Product	Electrical	Insulation Resistance Test at 500 VDC (Acceptance test)	IS-2500 (Part-1) 1992	VDE 0303 Part-3	NPCL Spec.	Test Report	2	1	1	
23.0		-do-	High voltage test (Acceptance test)	-do-	VDE 0611 Part-1	VDE 0611, Part-1	--do-	2	1	1	
24.0		-do-	Capacitance (Acceptance test)	-do-	NPCL Spec.	NPCLL Spec.	-do-	2	1	1	
25.0		Fire withstand	Fire retardant Test (Acceptance test)	-do-	UL-94	NPCL Spec.	-do-	2	1	1	
26.0		Corrosion Resistant	Thickness of Plating (Acceptance test)	-do-	NPCL Spec.	NPCL Spec.	-do-	2	1	1	
27.0		Physical	Dimension Check (Acceptance test)	-do-	NPCL Spec.	NPCL Spec.	-do-	2	1	1	

P - Performed by
 W - Witnessed by
 V - Verified by

1. Purchaser (NPCL)
 2. Prime Supplier
 3. External Laboratory



A4-10

**LIST OF MAJOR COMPONENTS
FOR LVS CONTROL PANEL
FOR PCPTF AT TARAPUR**

PCPTF/66320/2002/COM

REV No. : 00

Page 1 of 3

COPYRIGHT AND CONFIDENTIAL
The information contained in this document is the property of BHARAT HEAVY ELECTRICALS LIMITED
This must not be used directly or indirectly, in any manner detrimental to the interest of the company

PROJECT : PCP TEST FACILITY AT TARAPUR
PRODUCT : LIST OF MAJOR ITEMS FOR LVS CONTROL PANEL
CUSTOMER : M/S NPCIL
W.B.S ELEMENT NOs. : CE/1657-PR1-58-01

TITLE
**LIST OF MAJOR COMPONENTS
FOR LVS CONTROL PANEL
FOR PCPTF AT TARAPUR**

Dept Code
410

DRN.	NAME	SIGN	DATE
PREPARED	SURESH B / SISIR BALAGOPAL	-sd-	16.05.2022
CHECKED	JANAK KUMAR / BIRENDER NATH SHARMA	-sd-	16.05.2022
APPROVED	MALA SIBOO / PRAKASH D	-sd-	16.05.2022



A4-10

**LIST OF MAJOR COMPONENTS
FOR LVS CONTROL PANEL
FOR PCPTF AT TARAPUR**

PCPTF/66320/2002/COM

REV No. : 00

Page 2 of 3

REVISION HISTORY SHEET

REV No.	DATE	NATURE OF CHANGE	REASON	PREPARED BY	CHECKED BY	REVIEWED BY
00	16.05.2022	FIRST ISSUE	---	SB / SB	JK/BNS	MS/DP

COPYRIGHT AND CONFIDENTIAL
The information contained in this document is the property of BHARAT HEAVY ELECTRICALS LIMITED
This must not be used directly or indirectly, in any manner detrimental to the interest of the company

LIST OF MAJOR COMPONENTS

Sr.No	Description	Quantity	NPCIL / BHEL Specification	Remarks
1	Mosaic Grid (TOP AREA) No. of Row : 14 of 24mm, No. of Columns : 32 of 48mm Grid Size : 336mm(H) X 1536mm(W)	1	PC-E-314	
2	Mosaic Grid (LOWER AREA) No. of Row: 20 of 24mm, No. of Columns:32 of 48mm Grid Size : 480mm(H) X 1536mm(W)	1	PC-E-314	
3	Alarm Annunciator window with Front cover Replacable Facia. Voltage: 24V DC. Annunciator Window Size: 48x48mm.	40	PC-E-314	Colour will be finalised during detailed engineering
4	HAND SWITCH 4POLE, 2 Position; Size - 48(W) x 48(H) mm	14	PC-E-314	
5	Emergency push button 2 NO + 2 NC contacts; Size - 48(W)x24(H) mm Colour -Red; Shape - Round	14	PC-E-314	
6	2PB+2LED Module; Size - 48(W)x24(H) mm; PB COLOUR: Left-RED, Right - GREEN; LED COLOUR: Left-GREEN, Right - RED.	14	PC-E-314 PC-E-318	
7	Recessed PB module. Size - 48(W)x24(H) mm; Shape - Square, Colour - Black	1	PC-E-314	
8	Recessed PB module. Size - 48(W)x24(H) mm; Shape - Square, Colour - White	1	PC-E-314	
9	Recessed PB module. Size - 48(W)x24(H) mm; Shape - Square, Colour - Blue	1	PC-E-314	
10	Recessed PB module. Size - 48(W)x24(H) mm; Shape - Square, Colour - Green	1	PC-E-314	
11	Terminal Block; Screw-connection type; Suitable for 0.5 to 4 sq. mm. wires; Colour:Grey;	900	PC-E-409	
12	Relay 1 NO + 1 NC; Coil supply: 24 V DC, Contact Rating: 220 V DC	15	PC-E-298	
13	MCB, 16 A, 230 V AC, Double pole	4		
14	MCB, 3 A, 230 V AC, Double pole	6		
15	MCB, 2 A, 230 V AC, Double pole	3		
16	Door switch	2		
17	Exhaust Fans, 230 V AC	4		
18	LED Panel Illumination Lamp; 230 V AC	2		
19	Toggle switch DPST	2		
20	3-Pin Connector [Male Part] with Cap & Chain	4		
21	3-Pin Connector [Female Part] with Cap & Chain	4		
22	Wire .45sq. mm (14/36) / 1.5 / 2.5 sq.mm Teflon Coated With Lugs And Ferrules.	As Required		
23	Mounting arrangements for LVS and its accessories, components etc	As Required		
24	Inscriptions on Mosaic Tiles	As Required	PC-E-314	
25	Blank Tiles	As Required		Blank Tiles to put on the grid to cover the gaps between all the components
26	LED backlit LVS screen (75")	1 no	Annexure-2 of PS4102095	NOTE: MAKE OF THE PRODUCT SHALL BE PYROTECH/BARCO/DELTA/PLANER/MITSUBISHI OR EQUIVALENT* (*SUBJECT TO APPROVAL FROM NPCIL)
27	Display Controller	1 no		
28	Wall management software	1 lot		
29	Display Matrix switcher	1 no		
30	Compatible convertors/adapters/cables/any other accessories required for completeness of the display	1 lot		

Note: There may be minor changes in the list mentioned above and the changes have to be accommodated by the bidder.

NUCLEAR POWER CORPORATION OF INDIA LTD.
(A Government of India Enterprise)

SPECIFICATION No. PP-E-2061

TECHNICAL SPECIFICATION
FOR
REQUIREMENTS OF COMPONENTS/EQUIPMENT
FOR
INSTRUMENTATION ITEMS

REF. USI No.: 60000

REVISION No.	:	0	1		
DATE OF ISSUE (MONTH/YEAR)	:	July 2002	July 2010		
TOTAL No. OF PAGES (Including Cover Sheet)	:	34	37		

PREPARED BY	:	K. Narsimha Reddy	-Sd-	26/7/2002
		V. Satyanarayana	-Sd-	26/7/2002
CHECKED BY	:	K. R. Narasimhan	-Sd-	26/7/2002
		S. Ponnukkutti	-Sd-	26/7/2002
REVIEWED BY	:	Ravi Parkash	-Sd-	29/7/2002
		R. S. Vaghasia	-Sd-	29/7/2002
APPROVED BY	:	Umesh Chandra	-Sd-	29/7/2002
		V. K. Seth	-Sd-	29/7/2002
		(Name	Signature	Date)

(For revision, see revision control sheet)

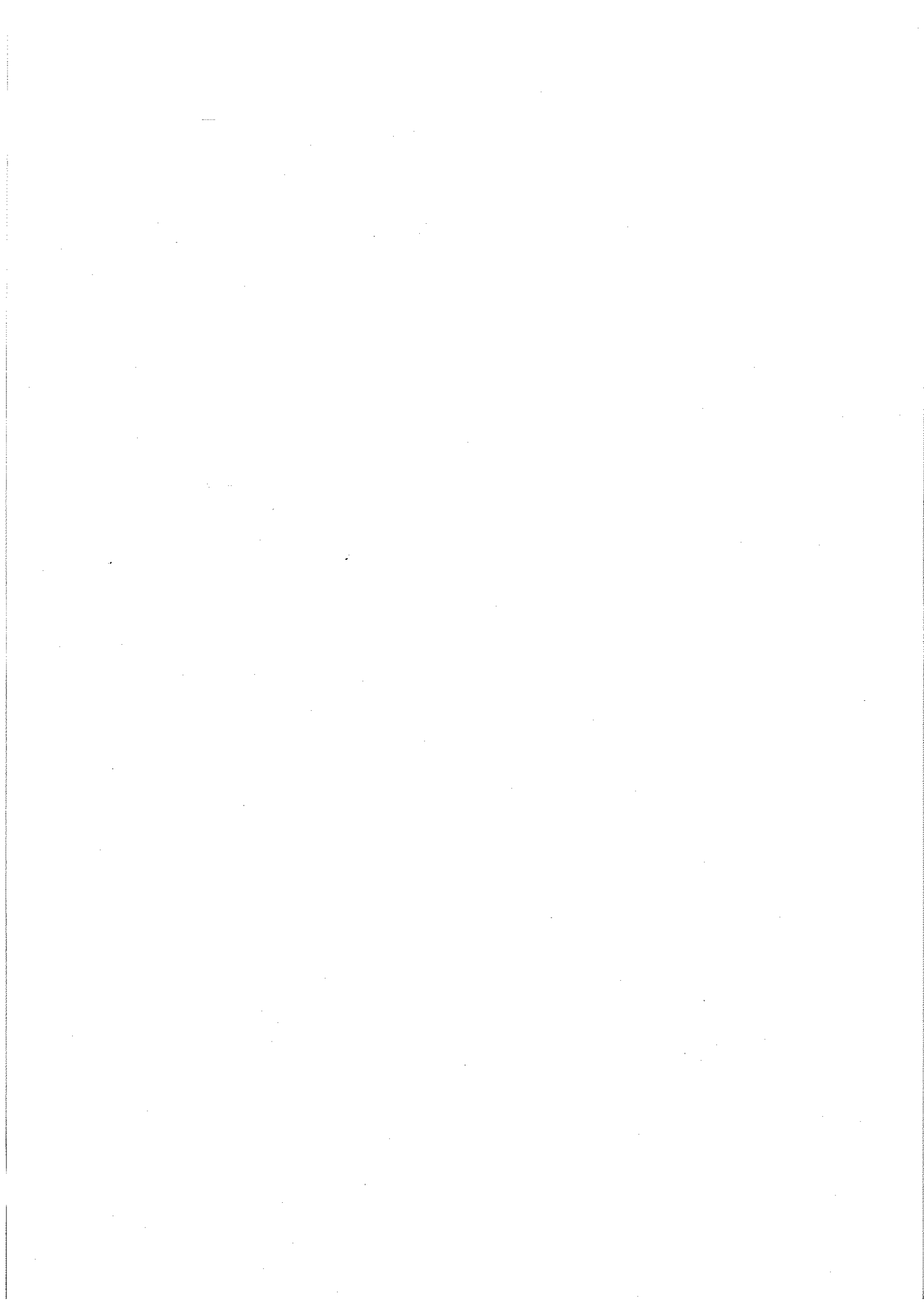

REVISION CONTROL SHEET

DOCUMENT TYPE: TECHNICAL SPECIFICATION

No.PP-E-2061/Rev.-1

TITLE: TECHNICAL SPECIFICATION
FOR
REQUIREMENTS OF COMPONENTS/EQUIPMENT
FOR
INSTRUMENTATION ITEMS

Rev. No. & Date	Description of Revision	Prepared By	Checked By	Reviewed by	Approved by
REV-1 JULY 2010	Revised and rewritten to add details pertaining to SMD, HMC, PC Hardware and its peripheral devices, rearranged some sections	<p><i>Vinay</i> Vinay Soni (C&I)</p> <p><i>Deepak</i> Deepak Kumar (C&I)</p> <p><i>M. Murali Mohan</i> M. Murali Mohan (QA)</p> <p><i>S.V. Subrahmanyam</i> S.V. Subrahmanyam (QA)</p> <p><i>B.V. Rao</i> B. V. Rao (REO) (R&D-C&I)</p>	<p><i>K. Reddy</i> 26/7/10 K Narsimha Reddy (REO)</p> <p><i>S.Roy</i> 27/7/10 S.Roy (C&I)</p> <p><i>S.K. Goswami</i> S.K. Goswami (R&D-ES)</p> <p><i>R.P. Jaiswal</i> R.P. Jaiswal (C&I)</p> <p><i>A.V. Ughade</i> A.V. Ughade (C&I)</p> <p><i>S. G. Bhandarkar</i> S. G. Bhandarkar (R&D-ES)</p> <p><i>K. Chandra</i> K.K. Chandra (C&I)</p>	<p><i>Mahendra Kelkar</i> M. G. Kelkar (C&I)</p> <p><i>S. Ramesh</i> 26/10/10 S Ramesh (QA)</p> <p><i>K. Agilandeshwari</i> K. Agilandeshwari (R&D-ES)</p> <p><i>S. Sarkar</i> S. Sarkar (ED)</p> <p><i>B. Ghoshal</i> B. Ghoshal (C&I)</p>	<p><i>Ravi Parkash</i> Ravi Parkash</p>

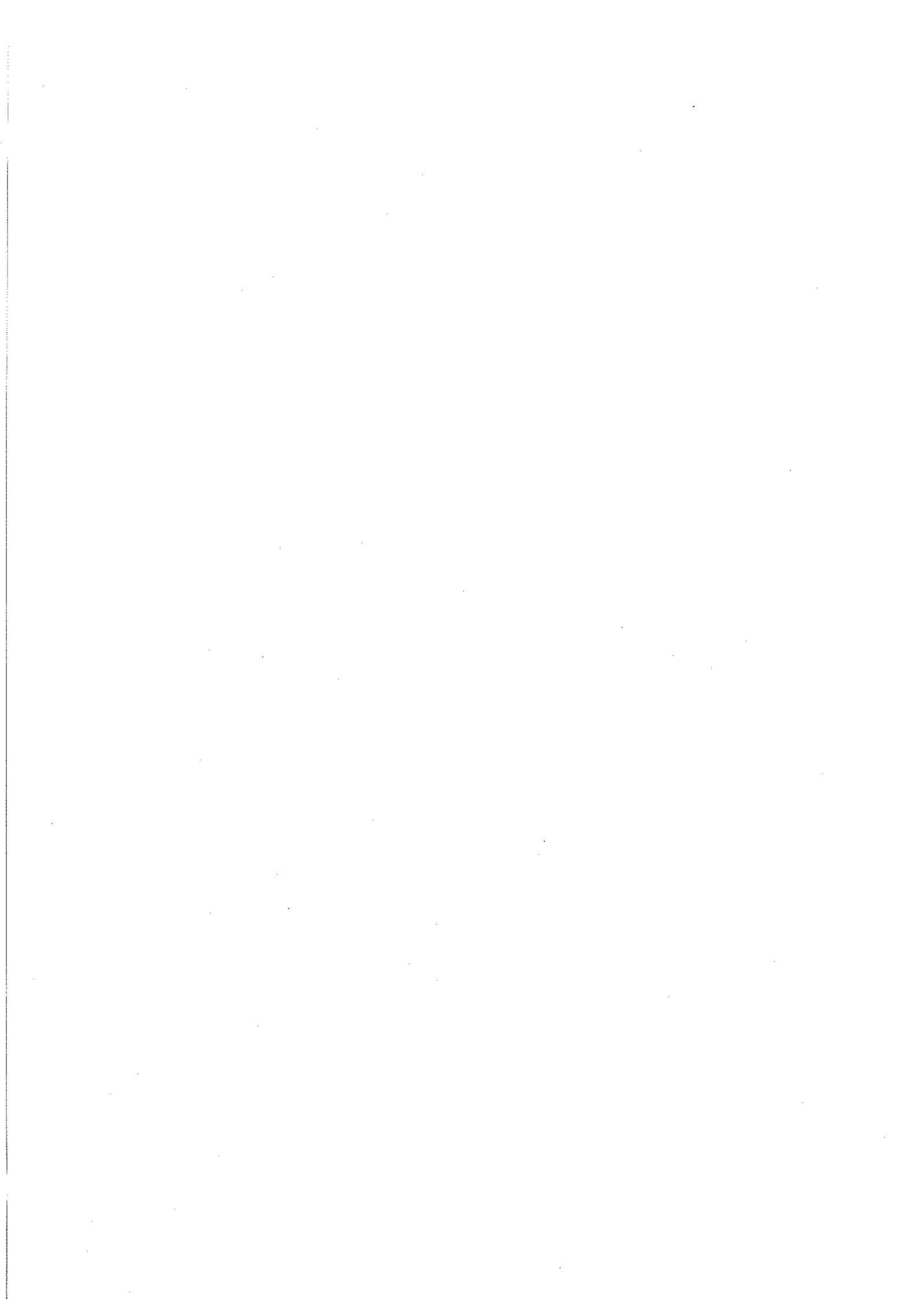

NUCLEAR POWER CORPORATION OF INDIA LIMITED	
TECHNICAL SPECIFICATION FOR REQUIREMENTS OF COMPONENTS/EQUIPMENT FOR INSTRUMENTATION ITEMS	PAGE No.:3 of 37 REV. No. : 1

INDEX

SECTION	TITLE	PAGE
1.0	SCOPE	5
2.0	ABBREVIATIONS	5
3.0	REQUIREMENTS	5
3.1	Components	6
3.1.1	Quality	6
3.1.2	Shelf life and Storage conditions	6
3.1.3	Seismic Aspects	6
3.2	Equipment	7
3.2.1	PCs, Peripherals and Network Hardware	8
3.3	Type Testing	8
4.0	INSPECTION	9
4.1	Components	9
4.1.1	Electronic/Electromechanical/Electrical	9
4.1.2	Surface mounted devices	9
4.1.3	Hybrid Micro Circuits (HMC)	10
4.2	Equipment	10
4.2.1	The Equipment/Instruments manufactured by the supplier	10
4.2.2	Bought out Items	10
4.2.3	PCs, Peripherals and Network Hardware	11
5.0	DEVIATIONS	11
6.0	DOCUMENTATION	11
6.1	Drawings	11
6.2	Instruction Manuals	12
6.3	Test Reports	12
6.4	Inspection History Docket (IHD)	12
7.0	SPARES	12
8.0	SUB-CONTRACTING	13
9.0	QUALITY SURVEILLANCE/ASSURANCE	13
10.0	PACKING	14
11.0	DELIVERY	14
11.1	Shipment with Deficiency	14
11.2	Spares	15
12.0	TRANSPORTATION	15
Annexure-A	Requirements for Procurement of Electronic Components	16
Annexure-B Section-A	Component's Inward Inspection	19
Annexure-B Section-B	Tests for Structural and Hardware items	27
Annexure-B Section-BB	Tests for Raw Materials, Non-critical Materials and Harness Materials, etc	28
Annexure-C	List of the items for which source inspection is to be carried out along with NPCIL QS.	33

NUCLEAR POWER CORPORATION OF INDIA LIMITED	
TECHNICAL SPECIFICATION FOR REQUIREMENTS OF COMPONENTS/EQUIPMENT FOR INSTRUMENTATION ITEMS	PAGE No.:4 of 37 REV. No. : 1

SECTION	TITLE	PAGE
Annexure-D	Proposal by supplier to NPCIL designer to use commercial grade components as per Annexure-A section 1.2.b and 1.3.b	35
Annexure-E	Proposal by supplier to NPCIL designer to use components used in earlier projects as per Annexure-A sec 2.2.b.1	36
Annexure-F	Proposal by supplier to NPCIL designer to use components as per Annexure-A sec 2.2.c	37

NUCLEAR POWER CORPORATION OF INDIA LIMITED	
TECHNICAL SPECIFICATION FOR REQUIREMENTS OF COMPONENTS/EQUIPMENT FOR INSTRUMENTATION ITEMS	PAGE No.:5 of 37 REV. No. : 1

1.0 SCOPE:

This specification covers the requirements regarding the design, manufacturing, inspection, testing, packing, delivery and guarantee of various Control and Instrumentation related items comprising of components (including electronic/electro-mechanical/electrical) and equipment (including mechanical/raw material/harness material) for Nuclear Power Projects. This specification shall be read along with the respective applicable specification as listed in the order for each of the respective items.

2.0 ABBREVIATIONS:

AQL	Acceptable Quality Level
CPLD	Complex Programmable Logic Devices
COC	Certificate of Compliance
CIR	Component Inspection Report
ETR	Equipment Test Report
EMI	Electro Magnetic Interference
EMC	Electro Magnetic Compatibility
EEPROM	Electrically Erasable Programmable Read Only memory
ERTL	Electronics Regional Test Laboratory
FPGA	Field Programmable Gate Array
HMC	Hybrid Micro Circuits
IPC	Institute for Interconnecting and Packaging Electronic Components
IS	Indian Standard
JEDEC	Joint Electron Devices Engineering Council
JSS	Joint Service Specification
LCOSO	Electronic Components Standardization Organization
LED	Light Emitting Diode
MIL	Military
PCB	Printed Circuit Board
PAL	Programmable Array Logic
QAP	Quality Assurance Plan
SMD	Surface Mounted Devices

3.0 REQUIREMENTS:

The activities like design, manufacture, inspecting, testing, etc. for the instruments shall be carried out according to the established engineering practices pertaining to industrial grade equipment, adopting the applicable national/international standard of process and codes of practice as described in following sections.

NUCLEAR POWER CORPORATION OF INDIA LIMITED	
TECHNICAL SPECIFICATION FOR REQUIREMENTS OF COMPONENTS/EQUIPMENT FOR INSTRUMENTATION ITEMS	PAGE No.:6 of 37 REV. No. : 1

3.1 Components:

3.1.1 Quality

- 3.1.1.1 Electronic (other than SMDs)/Electromechanical/Electrical:
The supplier shall use components of assured quality for all equipment as detailed in Annexure-A sec 1.1, 1.2 and 2.
- 3.1.1.2 SMDs
The supplier shall use components as detailed in Annexure-A sec. 1.3.
- 3.1.1.3 Connectors and Jumpers
In addition to the requirements of relevant specification, all connectors and Jumper shall be gold plated and shall be of class having maximum number of mating cycles.
- 3.1.1.4 Bins/Fascia plate for PCBs module/panel door gaskets.
All these shall be EMC qualifiable. Electronic card cages and Fascia plate for PCBs shall be plated.

3.1.2 Shelf life and Storage conditions

- 3.1.2.1 Electronic/Electromechanical/Electrical:
Long shelf life of components should be taken into consideration while procuring the components. Controlled storage conditions as specified in component datasheet need to be followed.
- 3.1.2.2 SMDs
All moisture sensitive SMDs should be handled and stored as per JEDEC J-STD-033B.1 standard or latest. For other SMDs controlled storage conditions as specified in component datasheet needs to be followed.

3.1.3 Seismic Aspects:

(i) Electronic (Passive & Active Electronic Components)

The components bought as per quality requirements given in section 3.1.1 will not be restrained for acceptable vibration data from supplier (as some manufacturers do not furnish any data within frequency range of 1 to 50Hz for 1g acceleration or above). However, finished equipment (as specified by relevant specifications), using these components, shall be subjected to the seismic evaluation test by the supplier. In case of components of significant size, whose leads are likely to be influenced in the

NUCLEAR POWER CORPORATION OF INDIA LIMITED	
TECHNICAL SPECIFICATION FOR REQUIREMENTS OF COMPONENTS/EQUIPMENT FOR INSTRUMENTATION ITEMS	PAGE No.:7 of 37 REV. No. : 1

frequency range of interest, adequate clamping arrangement shall be made.

(ii) Electromechanical Components:

a) Components with available vibration data for 5Hz and/or 10Hz onwards can be used even though specified requirement is 1Hz to 50Hz at 3.5g (typical) for horizontal axes and vertical axis. However, it would be necessary for the supplier to ensure that the vibration data available from manufacturer from 5Hz and/or 10Hz onwards provides adequate confidence that components will not fail during seismic testing of the assembled equipment using these components.

b) False contact operation during seismic test:

False contact operation of an electromagnetic relay/contactors shall not continue for more than 'X' milliseconds (to be specified by NPC for a particular case) during the entire period of seismic testing i.e. repetitive false operation for duration less than 'X' milliseconds will be acceptable.

(iii) Electrical Items

It would be necessary for the supplier to ensure that the items will not fail during seismic testing of the assembled equipment using these items.

(iv) Mechanical Items

It would be necessary for the supplier to ensure that the items will not fail during seismic testing of the assembled equipment using these items.

3.2 Equipment:

For meeting a part scope or full scope of a particular order, supplier's intent to directly procure assembled equipment from other sources shall be conveyed to NPCIL well in advance. Such procurement shall be initiated only after the approval of NPCIL.

These can be categorized as Custom-Built Equipment and Commercial off-the-shelf equipment.

For Custom-Built Equipment the supplier shall ensure this specification is complied at all stages. At the enquiry stage itself, the bidder manufacturers shall be asked by the supplier to submit details of their "Quality Assurance Plan" and "Inspection Plan" which shall be checked for use of reliable

NUCLEAR POWER CORPORATION OF INDIA LIMITED	
TECHNICAL SPECIFICATION FOR REQUIREMENTS OF COMPONENTS/EQUIPMENT FOR INSTRUMENTATION ITEMS	PAGE No.:8 of 37 REV. No. : 1

components, adequate incoming component inspection method and proper inspection/testing during manufacturing stages as well as after the finished stage.

Commercial off-the-shelf equipment, both indigenous as well as imported shall be procured from reputed manufacturers and shall meet NPCIL's specifications.

For all such equipment (Custom-Built as well as Commercial off-the-shelf), after placement of order by the supplier on the manufacturer, the detailed Quality Assurance Plan (QAP) and Test Procedure for verifying the requirement shall be obtained from the manufacturer of the equipment. These shall be submitted to NPCIL for approval. During approval of these documents necessary clause on Quality Surveillance on these equipment shall be included as mutually decided between the supplier and NPCIL.

3.2.1 PCs, peripherals and network hardware

All network hardware like network switches, media adapters, media converters, modems etc shall be Industrial grade or better.

Keyboards shall be rugged, water spill proof, with track pad wherever panel mountable. LCD monitors, printers can be of commercial grade with best of available in the market with highest operating temperature. They shall be quickly/easily replaceable and shall have mounting compatibility for panels. Standardization of same model for all systems shall be attempted.

Supplier shall procure PCs after obtaining approval from NPCIL.

3.3 Type Testing:

In case of new design, system/equipment prototype shall be fabricated as per accepted design and shall be subjected to performance test, seismic qualifications, environmental qualification, EMC qualification in accordance with the NPCIL approved Quality Assurance Plan (QAP)/ Test Procedure/ NPCIL specification for electromagnetic compatibility qualification of C&I systems. In addition, a 1000 hours stability test shall be carried out before seeking NPCIL clearance for regular production.

However during subsequent manufacturing of system/equipment based on identical design, for each lot Type test shall be carried out consisting of all the above tests except seismic test.

Tests specific to a system/equipment have to be carried out as per relevant specification / approved test procedure.

NUCLEAR POWER CORPORATION OF INDIA LIMITED	
TECHNICAL SPECIFICATION FOR REQUIREMENTS OF COMPONENTS/EQUIPMENT FOR INSTRUMENTATION ITEMS	PAGE No.:9 of 37 REV. No. : 1

4.0 INSPECTION:

4.1 Components

4.1.1 Electronic/Electromechanical/Electrical:

The supplier shall institute suitable procedure for the inward inspection on all components/material. As a minimum, for all the components the following shall be done.

- (a) Tests shall be carried out as per Annexure-B section A.
- (b) NPCIL will have the discretion to ask for any additional test, if necessary, but not covered by (a).

Based on the above, the supplier shall carry out inward inspection for all categories of components/materials.

Inward inspection and source inspection shall be done as per Annexure-B and Annexure-C respectively. In specific cases where design requirements demand, additional tests shall be carried out by the supplier.

For components not covered in Annexure-A separate proposal shall be made by the supplier covering the inspection that will be carried out. Any component not covered in Annexure-B but meeting component procurement policy as in Annexure-A will be inspected with test coverage as approved by NPCIL.

The supplier shall maintain component inspection reports (CIR) for each component. The CIR shall invariably indicate the order/(requisition) number.

Deviations, if any shall be submitted for review by QS, NPCIL and approval by C&I, NPCIL.

4.1.2 Surface Mounted Devices (SMD)

In inward inspection visual examination shall be carried out and date code shall be noted.

4.1.2.1 PCBs with SMD

For the SMD components which are difficult to be carried out inward inspection, before commencing bulk production 3% of the total nos. of PCBs of each type or one PCB whichever is higher shall be assembled as per PP-E-1443. PCB shall undergo thermal cycling (-25 to 55 deg Centigrade for 2 cycles), inspected as per PP-E-1443 and then baked at 65⁰C for 96 hours with power 'OFF' condition. After baking PCBs shall be free of component

NUCLEAR POWER CORPORATION OF INDIA LIMITED	
TECHNICAL SPECIFICATION FOR REQUIREMENTS OF COMPONENTS/EQUIPMENT FOR INSTRUMENTATION ITEMS	PAGE No.:10 of 37 REV. No. : 1

damages such as cracks on SMDs. Functional testing shall be carried out before and after the baking process. All the assembled PCBs shall pass through the functional requirements before and after baking. If any failure (functional or physical) is observed on any PCB after identification of component the lot of failed components shall be rejected. In case no failure is observed then bulk production can be initiated.

4.1.3 Hybrid Micro Circuits (HMC)

The supplier shall use components of assured quality as detailed in Annexure-A.

HMCs shall either be procured from QML-38534 i.e. qualified manufactures of HMC or evaluated and type tested as per relevant JSS/MIL.. MIL-PRF-38534 can be referred as guideline for evaluation/qualification of hybrid circuits.

4.2 Equipment:

4.2.1 The equipment/instruments manufactured by the supplier

- (i) The supplier shall institute proper inspection stages.
- (ii) The finished equipment shall be inspected as per the Engineering/manufacturing drawings approved by NPCIL.

4.2.2 Bought out Items:

- (i) For each of the imported bought out items where it is not source inspected, inspection and testing shall be carried out by the supplier after receipt of the same (in addition to the testing carried out by the manufacturer at his works). A detailed Quality Assurance Plan and Test Procedure including all requirements shall be submitted by the supplier to NPCIL for approval well in advance. The tests shall include 168 hours continuous performance test as well as stipulated climatic, seismic and EMC tests as per the respective applicable specification. The manufacturers for all such items shall, however, be identified by the supplier and deviations if any from NPCIL requirements shall be indicated to NPCIL and resolved before placement of purchase order by the supplier on the respective manufacturer.
- (ii) For each of the indigenous bought out items, the prospective vendor shall be identified by the supplier and shall be qualified on the basis of a prototype unit qualifying all tests (including tests for environmental qualification, seismic conditions and EMC) to meet the applicable specifications. The vendor's inward inspection procedure for components and manufacturing processes shall be evaluated jointly by the supplier and NPCIL. Components used for manufacturing such items shall be as per

NUCLEAR POWER CORPORATION OF INDIA LIMITED	
TECHNICAL SPECIFICATION FOR REQUIREMENTS OF COMPONENTS/EQUIPMENT FOR INSTRUMENTATION ITEMS	PAGE No.:11 of 37 REV. No. : 1

Annexure-A. The items shall be accepted on the basis of the tests (including type tests and 168 hours Burn-in Test) conducted as per the NPCIL approved detailed Quality Assurance Plan and Test Procedures to meet all the requirements stipulated as per respective applicable specification.

4.2.3 PCs, Peripherals and Network Hardware

Refer Annexure-C for inspection.

The supplier shall maintain Equipment Test Report (ETR) for each equipment. The ETR shall invariably indicate the order/ (requisition) number. Manufacturer/sub vendor who was already qualified for particular item can be considered after reassessment of the firm for that item.

5.0 DEVIATIONS:

If, during the execution of the contract any deviations from the given specifications with respect to equipment, sub-system, raw material or component are considered necessary by the supplier, supplier shall send the details of such deviations, in the DCR form for NPCIL's consideration.

6.0 DOCUMENTATION:

The Supplier shall be responsible for preparation of all the engineering/manufacturing drawings like, General Arrangement drawings, Bill of Materials, Component Layout Drawings, Wiring Diagrams, drawing list, etc. for each item, and also for design basis report for new conceptual designs, quality assurance plan as stipulated by the respective applicable specifications and test procedures necessary for the execution of the works. All these documents shall be submitted for NPCIL approval prior to commencement of the related activity.

In addition to the hard copies mentioned below, 5 sets of soft copies in CD form are also to be supplied.

6.1 Drawings

One set of reproducible on a Dilar or Mylar base corresponding to as-built information shall be supplied by supplier for each type of equipment supplied against the order at no extra cost. The reproducible will be dispatched by the supplier within one month after shipping release of the related equipment, is obtained.

All the drawings shall be distinctly marked with the Project name and the units (i.e. 1,2...etc.) in the Title Block.

The Title Block shall also describe:

NUCLEAR POWER CORPORATION OF INDIA LIMITED	
TECHNICAL SPECIFICATION FOR REQUIREMENTS OF COMPONENTS/EQUIPMENT FOR INSTRUMENTATION ITEMS	PAGE No.:12 of 37 REV. No. : 1

- (a) Section and Part Equipment.
- (b) Drawing or Index Title.

6.2 Instruction Manuals

The supplier shall submit, at no extra cost, 10 hard copies & one soft copy of the operating and maintenance instruction manuals. Operating/instruction manuals shall include but not necessarily be limited to the following:

- (a) General Information
- (b) Principal Technical Data
- (c) Description of components including manufacturer's catalogue where considered necessary by the Contractor for devices furnished on the equipment.
- (d) Material and part list sufficiently detailed for ordering renewal parts.
- (e) Complete sets of reference drawings.

The above manuals shall be shipped within one month of the shipment of the equipment.

6.3 Test Reports

5 copies of test reports are to be submitted.

6.4 Inspection History Docket (IHD)

During the manufacturing process, an Inspection History Docket shall be compiled by the supplier and shall include the following:

- a) Requisition/Purchase Order and Information Transmittal Form (for requisitions only)
- b) List of drawings (Manufacturing drawings and NPCIL approved)
- c) Inspection Procedures
- d) Stage Inspection reports & Component Inspection Report:
(Self certification by supplier and CIRs for source inspected equipment)
- e) Test reports
- f) QS Reports
- g) Design Concession Requests (DCRs)
- h) Shipping Releases

7.0 SPARES:

The spares to be supplied under the contract unless otherwise specified in the relevant specification shall be on the following basis:

NUCLEAR POWER CORPORATION OF INDIA LIMITED	
TECHNICAL SPECIFICATION FOR REQUIREMENTS OF COMPONENTS/EQUIPMENT FOR INSTRUMENTATION ITEMS	PAGE No.:13 of 37 REV. No. : 1

- (a) 15% of the PCBs, sub-assemblies and units with at least two units.
- (b) 5% of hardware items like connectors, switches, etc. used on the equipment with at least one of each type.
- (c) 10% of non PCB mounted components like filter capacitors, bleeder resistors, power transistors, SCR, consumables like fuses, indicating lamps etc.

A list of proposed spares shall be prepared by the supplier taking care of the above requirements. In addition, the supplier shall prepare list of recommended spares accounting for stipulated Maintenance needs, obsolescence, for all critical and custom built components. Both these lists shall be submitted to NPCIL for prior approval.

8.0 SUB CONTRACTING:

The order is placed with the understanding that all the jobs related with its fulfillment like mechanical fabrication, assembly, painting, etc. will be carried out by the supplier in their own workshop. If due to any reason the supplier decides to get any job fabrication or otherwise done by a sub-contractor, prior approval from NPCIL shall be obtained. NPCIL will have the discretion to evaluate/assess the sub-contractor before according the approval. In all such cases the supplier shall institute proper inspection stages to prevent last minute rectification and avoidable delays. A failure/deviation at any stage shall be immediately intimated to QS; NPCIL.

9.0 QUALITY SURVEILLANCE/ASSURANCE:

The organizational structure at the supplier's works shall have provision for an independent IQC (Internal Inspection & Quality Control) and QAD (Quality Assurance Department) so as to perform various inspection and tests to ensure quality aspects envisaged vide the above paragraphs and the respective applicable specifications.

The QS NPCIL, shall have uninhibited access to supplier's/sub-contractor's works during the currency of the Contract for the purpose of ensuring that the manufacturing and inspection processes for the items conform to the requirements laid down in the order and for the purpose of witnessing and/or carrying out the various tests envisaged in the respective applicable specification.

There shall be no delivery made by the supplier, without a shipping release in writing by the QS, NPCIL.

All correspondence shall be as per agreed procedure and its amendments from time to time.

NUCLEAR POWER CORPORATION OF INDIA LIMITED	
TECHNICAL SPECIFICATION FOR REQUIREMENTS OF COMPONENTS/EQUIPMENT FOR INSTRUMENTATION ITEMS	PAGE No.:14 of 37 REV. No. : 1

10.0 PACKING:

The supplier shall arrange packing of various items as per IRCA regulations in respect of consignments sent by rail. In respect of dispatches by road, the supplier shall arrange such packing as would safeguard the consignment against all rigors of road transport. All accessories and components shall be packed in packages limited to the sizes and weights that are admissible under the prevailing rail and road limitations. The instruments shall be so packed and protected as not to suffer deterioration, damage or breakage and shall be protected to prevent entrance of dirt and moisture during transit and storage. Each package shall be properly labeled and tagged indicating the type of quality of material it contains its dimensions, weight as well as the order number (Requisition No.). All hardware, spares, etc. shall be specially packed and clearly marked indicating the intended use.

11.0 DELIVERY:

All deliveries shall be made to the consignee within the stipulated delivery dates.

11.1 Shipment with deficiency

Generally no shipment shall be made with deficiency. However, because of urgency or some other unavoidable reasons, shipment with deficiency can be made only after obtaining the approval of C&I, NPCIL. In such cases the supplier shall clear the deficiencies at site at no extra cost and within the agreed schedule. The supplier shall also conduct free of cost fresh tests on the equipment if required to ensure the integrated system performance. Also the supplier shall maintain a list of all such deficiencies, accepted date of clearing and reference for clearance. The supplier shall update this list every month and issue it to all concerned for the sake of record and speedy clearance of such deficiencies.

This option for shipment with deficiency shall be exercised without any prejudice to the agreed commercial 'Terms & Conditions' of the order.

11.2 Spares

The spares shall be delivered as far as possible along with the shipment of the last lot of the instruments. Where this is not possible, spares shall be supplied within 3 months of the last shipment of the last lot, however, within the stipulated date for completion of the order without any prejudice to the agreed commercial 'Terms & Conditions' of the order.

Each item shall be packed in independent packets and kept in cardboard box with adequate identification for the contents of each packet. All such small cardboard boxes shall be packed in an appropriate sized cardboard box in

NUCLEAR POWER CORPORATION OF INDIA LIMITED	
TECHNICAL SPECIFICATION FOR REQUIREMENTS OF COMPONENTS/EQUIPMENT FOR INSTRUMENTATION ITEMS	PAGE No.:15 of 37 REV. No. : 1

accordance with the packing quality requirements for shipment to the respective destinations and with the contents certified by QS NPCIL.

12.0 TRANSPORTATION:

The supplier shall make all arrangements for transportation upto the NPCIL's respective project site.

NUCLEAR POWER CORPORATION OF INDIA LIMITED	
TECHNICAL SPECIFICATION FOR REQUIREMENTS OF COMPONENTS/EQUIPMENT FOR INSTRUMENTATION ITEMS	PAGE No.:16 of 37 REV. No. : 1

Annexure-A
Requirements for procurement of Electronic Components

The following are the requirements for the procurement of various components, which shall be used for manufacturing of items/systems.

1. Imported Components:

1.1 Passive electronic devices, electromechanical devices, etc.

Devices meeting International Standards like DIN/VDE/CSA/UL etc., with Certificate of Compliance (preferably in a format covering all the aspects as stated in the sample COC) from the manufacturer or his authorized agent.

1.2 Discrete semiconductors and IC's(Through hole, Hybrid modules)

- a) MIL (Temperature grade)/Industrial grade devices meeting operating temperature of -10°C to $+85^{\circ}\text{C}$ or better with Certificate of Compliance (format attached) from the manufacturer or his authorized representative. If the COC is not available then the devices shall be screened as per Note 1.
- b) If devices as per Para (a) are not available in the MIL (Temperature grade)/Industrial grade but are essential for the design, then Commercial grade devices can be used in the design with prior approval from NPCIL(proforma as per Annexure-D). Commercial grade devices should be used with Certificate of Compliance (format attached) from the manufacturer or his authorized representative and screening as per Note 1.

Note1: 100% Stabilization Bake (24 Hours) similar to MIL-883 H screening method 1008.2 and temperature cycling (10 cycles) similar to MIL-883 H screening method 1010.8. However the test temperature range shall be covering storage temperature of the respective device as given in the catalogue. The screening tests can be conducted either at supplier's testing laboratory if found acceptable by QS, NPCIL or at an approved testing laboratory like ERTL etc.

1.3 Discrete semiconductors and IC's (SMDs)

- a) MIL (Temperature grade)/Industrial grade devices meeting operating temperature of -10°C to $+85^{\circ}\text{C}$ or better with Certificate of Compliance (format attached) from the manufacturer or his authorized representative.
- b) If devices as per Para (a) are not available in the MIL (Temperature grade)/Industrial grade but are essential for the design, then Commercial

NUCLEAR POWER CORPORATION OF INDIA LIMITED	
TECHNICAL SPECIFICATION FOR REQUIREMENTS OF COMPONENTS/EQUIPMENT FOR INSTRUMENTATION ITEMS	PAGE No.:17 of 37 REV. No. : 1

grade devices can be used in the design with prior approval from NPCIL(proforma as per Annexure-D). Commercial grade devices should be used with Certificate of Compliance (format attached) from the manufacturer or his authorized representative.

Note: SMDs shall be procured in Tape/reel/tube/ tray packing only in order to facilitate automatic component placement and assembly. To the extent possible SMD components having moisture sensitivity level 1 (unlimited floor life) should be procured as defined in JEDEC-J-STD-020D.1 or latest.

2. Indigenous Components:

2.1 Passive components including electromechanical devices.

JSS approved components from manufacturer with valid LCSO approval and with routine test certificate and CERTIFICATE OF COMPLIANCE.

2.2 Discrete semiconductors and Hybrid Micro circuits

- a) JSS approved components from manufacturer with valid LCSO approval and with routine test certificate and CERTIFICATE OF COMPLIANCE. If the COC is not available then the devices shall be screened as per Note 1 in section 1.2.
- b) Components from reputed manufacturer's i.e.
 1. Vendors in NPCIL's earlier projects with certificate from supplier (proforma as per Annexure-E) or
 2. Earlier LCSO qualified manufacturer presently does not have LCSO approval

with Batch Acceptance Test certificates as per relevant JSS/IS.

- c) Components not meeting a & b and proposed to be used will have to be approved by NPCIL with appropriate tests (proforma as per Annexure-F)

3. Inspection:

Each of the imported as well as indigenous components shall be inspected as per the inward inspection policy (see Annexure-B, Section-A) on its receipt. Inspection Level II, AQL (Acceptable Quality Level) 1%, Single Sampling in addition to 100% acceptance tests for Group A Tests (IS-10673) shall be applicable for this purpose. However, the commercial grade devices (as per 1.2b above) shall be inspected as per inspection inward policy, after Stabilization Bake and Temperature Cycling. Failed components shall not be used.

NUCLEAR POWER CORPORATION OF INDIA LIMITED	
TECHNICAL SPECIFICATION FOR REQUIREMENTS OF COMPONENTS/EQUIPMENT FOR INSTRUMENTATION ITEMS	PAGE No.:18 of 37 REV. No. : 1

**SAMPLE
CERTIFICATE OF COMPLIANCE
(Imported Components)**

It is hereby certified that all the materials, products, articles supplied vide our Invoice No..... have been manufactured, inspected/tested and are in conformance with all requirements, applicable documents and other specifications as given in your purchase order No..... and manufacturer's specifications.

Required test and traceability documentation are on file and available for review by your representative at any reasonable time.

Signature:
Office seal:

**CERTIFICATE OF COMPLIANCE
(Indigenous Components)**

We hereby certify that the basic raw materials, processes and workmanship used for the ...(name of the components).....supplied under our invoice No..... against your purchase order No.....are in accordance with JSSand meet all the requirements of JSS..... .Our components are approved by LCSO and this certificate is issued in lieu of Batch acceptance Certificate.

Signature:
Office seal:

NUCLEAR POWER CORPORATION OF INDIA LIMITED	
TECHNICAL SPECIFICATION FOR REQUIREMENTS OF COMPONENTS/EQUIPMENT FOR INSTRUMENTATION ITEMS	PAGE No.:19 of 37 REV. No. : 1

**Annexure-B
Section-A
COMPONENT'S INWARD INSPECTION**

S.No	COMPONENT	100% ACCEPTANCE TESTS	GROUP 'A' ACCEPTANCE TESTS (SAMPLING)
1	Signal Diodes Ref: JSS: 51301	1. Visual examination 2. Reverse leakage current at 25°C. 3. Forward voltage drop	1. Break down voltage
2	Rectifiers Ref: JSS: 51305/51306	1. Visual examination 2. Reverse leakage current at 25°C. 3. Forward voltage drop	
3	Zener diodes Ref: JSS: 51302	1. Visual examination 2. Zener breakdown voltage.	1. Reverse leakage current at 25°C 2. Zener impedance 3. Forward voltage (if specified)
4	Voltage reference diodes Ref: JSS: 51303	1. Visual examination 2. Zener breakdown voltage	1. Zener impedance
5	Transistors Ref: JSS: 51300 JSS: 51325	1. Visual examination 2. Cut off current collector to base I_{cbo} (or I_c if specified) 3. Forward current transfer ratio (hfe)	1. Breakdown voltage BV CE O 2. Breakdown voltage BV BE O 3. Breakdown voltage BV BC O 4. VBE and VCE saturation
6	Field effect transistors Ref: JSS: 51330	1. Visual examination 2. Reverse current: gate to source. 3. Drain current	1. Breakdown voltage: gate to source. 2. Cut off voltage: gate to source.
7	Silicon controlled rectifiers Ref: JSS: 51320	1. Visual examination 2. Forward blocking current 3. Reverse blocking current 4. Gate trigger current	1. Gate trigger voltage and current 2. Forward voltage drop 3. Holding current
8	Uni.-junction transistors Ref: JSS: 51323	1. Visual examination 2. Intrinsic stand off ratio 3. Break point current	1. Inter base resistance 2. Emitter saturation voltage 3. Emitter reverse current

NUCLEAR POWER CORPORATION OF INDIA LIMITED	
TECHNICAL SPECIFICATION FOR REQUIREMENTS OF COMPONENTS/EQUIPMENT FOR INSTRUMENTATION ITEMS	PAGE No.:20 of 37 REV. No. : 1

S.No.	COMPONENT	100% ACCEPTANCE TESTS	GROUP 'A' ACCEPTANCE TESTS (SAMPLING)
9	Operational amplifiers Ref: JSS: 51452/51453	1. Visual examination 2. Input offset voltage 3. Input bias current 4. Input offset current 5. Large signal voltage gains	1. Output short circuit test (If specified) 2. Power supply current
10	Voltage regulators Ref: JSS: 51451	1. Visual examination 2. Input quiescent current 3. Load regulation 4. Line regulation 5. Reference voltage	1. Output voltages 2. Short circuit current
11	Digital ICs Ref: JSS: Applicable 51400 Series	1. Visual examination 2. Verification of functions against truth tables	1. '0' level output voltage 2. '1' level output voltage 3. '1' level supply current, if specified 4. '0' level supply current, if specified
12	Voltage comparators Ref: JSS: 51454	1. Visual examination 2. Input offset voltage 3. Input bias current 4. Gain	1. Supply Current
13	LED's Ref: JSS: 51318	1. Visual examination 2. Glow check	1. Forward voltage drop 2. Reverse leakage current
14	Polyester capacitors Ref: IS: 9256/IS 9638 JSS: 50200 JSS: 50212	1. Visual examination 2. Capacitance value (more than 10pf) 3. Voltage proof check (as a flash test for 2 seconds)	1. Dimensions 2. Insulation resistance check 3. Tangent of loss angle check
15	Aluminium Electrolytic capacitors Ref: IS: 4317 JSS: 50203	1. Visual examination 2. Capacitance value 3. Tangent of loss angle check 4. Leakage current	1. Insulation resistance check 2. Voltage proof check

NUCLEAR POWER CORPORATION OF INDIA LIMITED	
TECHNICAL SPECIFICATION FOR REQUIREMENTS OF COMPONENTS/EQUIPMENT FOR INSTRUMENTATION ITEMS	PAGE No.:21 of 37 REV. No. : 1

S.No	COMPONENT	100% ACCEPTANCE TESTS	GROUP 'A' ACCEPTANCE TESTS (SAMPLING)
16	Ceramic Dielectric capacitors Ref:IS: 2786 JSS: 50200 JSS: 50208/50209	1. Visual examination 2. Capacitance value (More than 10pf) 3. Tangent of loss angle check 4. Voltage proof check (as a flash test for 2 seconds)	1. Insulation resistance check
17	Glass dielectric capacitors Ref: JSS: 50210	1. Visual examination 2. Voltage proof check (2 sec.) 3. Capacitance value (More than 10pf)	1. Dimensions (outline) 2. Tangent of loss angle check 3. Insulation resistance check 4. Voltage proof check for 60seconds
18	Polystyrene capacitors Ref:IS: 5475 JSS: 50211	1. Visual examination 2. Capacitance value (more than 10pf) 3. Voltage proof check for 2seconds 4. Tangent of loss angle check	1. Dimensions (outline) 2. Insulation resistance check
19	Solid tantalum electrolytic capacitors Ref: JSS: 50205	1. Visual examination 2. Voltage proof (2seconds) 3. Capacitance 4. Leakage current check	1. Dimensions (outline) 2. Tangent of loss angle check 3. Insulation resistance check
20	Fixed resistors Ref: JSS: 50401	1. Visual examination 2. Resistance value check	1. Dimensions (outline) 2. Insulation resistance test (for moulded type only) 3. Temperature rise test (if >1 watt)
21	Fixed resistors, high Wattage Ref: JSS: 50401/50402	1. Visual examination 2. Resistance value check	1. Dimensions (outline) 2. Insulation resistance test (for moulded type only) 3. Temperature rise test (if >1 watt)

NUCLEAR POWER CORPORATION OF INDIA LIMITED	
TECHNICAL SPECIFICATION FOR REQUIREMENTS OF COMPONENTS/EQUIPMENT FOR INSTRUMENTATION ITEMS	PAGE No.:22 of 37 REV. No. : 1

S.No	COMPONENT	100% ACCEPTANCE TESTS	GROUP 'A' ACCEPTANCE TESTS (SAMPLING)
22	Fixed wire wound resistors Ref: JSS: 50470/50471	1. Visual examination 2. Resistance value check	1. Dimensions (outline) 2. Insulation resistance test (only for moulded type only) 3. Temperature rise test
23	Non wire-wound potentiometers Ref: IS: 5475 JSS: 50500/50501	1. Visual examination 2. Resistance value	1. Resistance law test (except trim pots & single turn pots) 2. Insulation resistance check
24	Wire wound potentiometers Ref: JSS: 50502	1. Visual examination 2. Continuity check. 3. Total resistance check	1. Dimensions (outline) 2. Resistance law test (for multi-turn potentiometers) 3. Voltage proof test 4. Insulation resistance test
25	Turn counting potentiometers dials	1. Visual examination 2. Suitability with potentiometers	1. Dial operation & snap action of digits 2. Locking arrangement 3. Dimensions check
26	Inductors and chokes	1. Visual examination 2. DC winding resistance 3. Inductance value check 4. Voltage Proof Test 5. Insulation resistance check	1. Dimensions check 2. Q factor check, if specified
27	Relays Ref: JSS: 50700 JSS: 50701/50711	1. Visual inspection 2. Operation (pick up and drop out voltage) 3. Time delay (for time delay relays)	1. Voltage proof test 2. Insulation resistance check 3. Switching time 4. Contact resistance check 5. Coil resistance check 6. Dimensions
28	Sockets for relays Ref: JSS: 52802 IS: 1293	1. Visual examination 2. High voltage test	1. Contact resistance 2. Matching check with relay 3. Interchangeability (one no. only) 4. Insulation resistance check
29	Reed relays Ref: JSS: 50703	1. Visual examination 2. Static contact resistance Check	1. Dimensions check 2. Coil resistance check 3. Operation & release time

NUCLEAR POWER CORPORATION OF INDIA LIMITED	
TECHNICAL SPECIFICATION FOR REQUIREMENTS OF COMPONENTS/EQUIPMENT FOR INSTRUMENTATION ITEMS	PAGE No.:23 of 37 REV. No. : 1

S.No	COMPONENT	100% ACCEPTANCE TESTS	GROUP 'A' ACCEPTANCE TESTS (SAMPLING)
		3.Pickup & dropout voltage Check 4.Voltage proof test for 2 seconds	check (>5 milliseconds) 4.Insulation resistance test
30	Contactors Ref:IS: 13947	1.Visual examination 2.Operating test	1.Temperature rise test on 1 NO only (Up to 90 Amps A.C.) 2.Dielectric strength test 3.Insulation resistance test 4.Contact resistance check
31	A.C. Circuit breakers Ref:IS: 13947 and IS 13118 (Part II, Sec.1.66)	1.Mechanical operation test 2.High voltage test 3.Tripping time test	1.Temperature rise test (Up to 90 Amps A.C.) 2.Insulation resistance test
32	Miniature circuit breakers Ref: JSS: 59201	1.Visual examination 2.Voltage proof test 3.Operation check	1.Dimensions check 2.Tripping time check 3.Insulation resistance test
33	Toggle switches Ref: JSS: 51200 JSS: 51201 IS: 3452	1.Visual examination 2.Circuitry	1.Contact resistance 2.Voltage proof check 3.Insulation resistance check
34	Sensitive switches Ref: JSS: 51204	1.Visual examination 2.Functional operation (Electrical) 3.Voltage proof (2seconds)	1.Dimensions (outline) 2.Contact resistance check 3.Insulation resistance check
35	Rotary wafer switches Ref:IS: 2628 JSS: 51207	1.Visual examination 2.Circuitry.	1.Voltage proof test 2.Contact resistance test 3.Insulation resistance test
36	Push button switches Ref:IS: 4794 JSS: 51205	1.Visual examination 2.Functional check	1.Contact resistance test 2.Insulation resistance test 3.Voltage proof test

NUCLEAR POWER CORPORATION OF INDIA LIMITED	
TECHNICAL SPECIFICATION FOR REQUIREMENTS OF COMPONENTS/EQUIPMENT FOR INSTRUMENTATION ITEMS	PAGE No.:24 of 37 REV. No. : 1

S.No	COMPONENT	100% ACCEPTANCE TESTS	GROUP 'A' ACCEPTANCE TESTS (SAMPLING)
37	Heavy duty air break switches and composite units of air break switches and fuses (for voltages not exceeding 1000 volts) Ref:IS:4064	1.High voltage test	1.Temperature rise at rated current (Maximum 60 Amperes) test on 1 No. Sample only
38	Miniature connectors Rack panel Ref: JSS: 50820	1.Visual examination 2.Voltage proof (2seconds)	1.Contact resistance check 2.Insulation resistance check
39	PCB Connectors Ref: JSS: 50805	1.Visual examination 2.Voltage proof test	1.Contact resistance test 2.Insulation resistance test 3. Solderability of terminals
40	Terminals (for electronic equipment) Ref:IS: 4007 JSS: 52720	1.Visual examination	1.Contact resistance test 2.High voltage test 3.Insulation resistance test 4.Solderability,if applicable
41	Indicating lamps Ref:IS: 1901	1.Visual examination 2.Glow test	1.Current at full Voltage test
42	Lamp holders Ref:IS: 4795	1.Visual examination	1.Voltage proof test 2.Insulation resistance test 3.Mating with lamp
43	Indicating meters Ref:IS: 1248 JSS: 51800 JSS: 51820	1.Visual examination 2.Position influence 3.Sticking below zero 4.Accuracy 5.Voltage proof check 6.Insulation resistance	1.Zero adjustment 2.Damping 3.Power consumption 4.Dimensions (outline)

NUCLEAR POWER CORPORATION OF INDIA LIMITED	
TECHNICAL SPECIFICATION FOR REQUIREMENTS OF COMPONENTS/EQUIPMENT FOR INSTRUMENTATION ITEMS	PAGE No.:25 of 37 REV. No. : 1

S.No	COMPONENT	100% ACCEPTANCE TESTS	GROUP 'A' ACCEPTANCE TESTS (SAMPLING)
44	Servomotors (2 Ø induction motors) Ref: JSS: 54200 JSS: 54201	1. Visual examination 2. Voltage proof test 3. Insulation resistance test 4. Direction of rotation check 5. No load speed test 6. Starting voltage check 7. Power 8. Current 9. Single phasing 10. Stall torque	1. Temperature rise 2. Life (electrical) 250 hrs
45	Fuse low voltage Ref: JSS: 51901	1. Visual examination 2. Continuity check.	1. Dimensions (outline) 2. Current carrying capacity (Up to 90 Amperes A. C.) 3. Blow test (on 3 Nos. only)
46	Fuse holder: extractor type Ref: JSS: 52501	1. Visual examination 2. Compatibility with fuse link 3. Voltage proof (2seconds)	1. Dimensions (outline) 2. Insulation resistance check
47	HRC Fuse links Ref: IS: 13703	1. Visual examination 2. Type marking & suitability	1. Dimensions check 2. Minimum fusing current 3. Blow test (max. 60 Amp.) on 3 Nos. only. 4. Non-fusing current test
48	HRC Fuse carriers Ref: BS-88	1. Visual examination 2. Type marking & suitability 3. Voltage proof test	1. Dimensions check 2. Insulation resistance check 3. Compatibility with fuse link
49	Polyethylene insulated (Copper & Aluminum) PVC Sheathed Cables (Up to 230 volts) Ref: IS: 1596	1. Visual examination	1. Resistance test 2. Thickness of Insulation & Sheath 3. Voltage proof test 4. Insulation resistance check 5. Solderability and fire retardant Test (destructive) 6. Voltage proof test

NUCLEAR POWER CORPORATION OF INDIA LIMITED	
TECHNICAL SPECIFICATION FOR REQUIREMENTS OF COMPONENTS/EQUIPMENT FOR INSTRUMENTATION ITEMS	PAGE No.:26 of 37 REV. No. : 1

S.No	COMPONENT	100% ACCEPTANCE TESTS	GROUP 'A' ACCEPTANCE TESTS (SAMPLING)
50	Low frequency PVC wires, cables with PVC sheath Ref:IS: 5608	1. Visual examination	1. Dielectric strength 2. Insulation resistance (at 40°C) 3. Resistance of conductor 4. Measurement of dimensions 5. Solderability and fire retardant test (destructive) 6. Voltage proof test
51	Loud speakers Ref:IS: 7741 JSS: 55301	1. Visual examination 2. D C resistance check 3. Impedance at 1000 Hz. 4. Insulation resistance check	1. Dimensions check 2. Frequency response test
52	EPROM/EEPROM	1. Visual examination 2. Blank Test	Programming (Repeated read and write cycles)
53	PAL	1. Visual examination 2. Blank test	Programming if Applicable
54	Surface Mounted Devices	1. Visual examination 2. Date code	_____
55	Microcontroller	1. Visual examination 2. Verification from part No.	_____
56	Microprocessor	1. Visual examination 2. Verification from part No.	_____
57	FPGA/CPLD	1. Visual examination 2. Verification from part No.	_____

Note 1. Visual examination should include checking of Finish, Workmanship, Marking, Polarity marking and External damages.

2. For all VLSICs viz., microprocessors, programmable array logics, memory chips, interface devices and peripheral components functional checks shall be done on individual components. Wherever it is not possible, mounting in a suitable PWB with socket shall be used to test the devices.

NUCLEAR POWER CORPORATION OF INDIA LIMITED	
TECHNICAL SPECIFICATION FOR REQUIREMENTS OF COMPONENTS/EQUIPMENT FOR INSTRUMENTATION ITEMS	PAGE No.:27 of 37 REV. No. : 1

Annexure-B

Section-B

Tests for Structural and Hardware items

(Inspection reports have to be submitted)

1. Copper Flats/Strips:

Visual checks : Straightness and other surface defects.

Dimensional checks : As per IS: 1897

Bending : As per IS: 1897

2. Painting Materials:

Functional check : The test material will be sprayed/coated on the test coupons and the following aspects are checked. Brittleness: (in paint itself), adhesion, scratch hardness (on paints only): As per IS: 101.

Shade : AS per IS: 5 with standard sample coupon (on paints only)

Thickness : Gauge

Adhesion : With Cellulose Tape

3. Enameled (as per IS: 13730) Copper Wires:

Visual inspection : Visual examination

Dimensional check : Gauge measurement

Functional check : (1) Resistance measurement for one metre length

(2) Breakdown voltage test

(3) Solderability test

4. PVC/Teflon Cables & Wires:

(JSS 51001, MIL-W-168781)

Visual inspection : Finish, centering of conductor, number and diameter of the conductors, and type of insulation.

Functional check : Resistance test, Solderability test, and dielectric test, insulation resistance test, flame retardant test.

NUCLEAR POWER CORPORATION OF INDIA LIMITED	
TECHNICAL SPECIFICATION FOR REQUIREMENTS OF COMPONENTS/EQUIPMENT FOR INSTRUMENTATION ITEMS	PAGE No.:28 of 37 REV. No. : 1

**Annexure-B
Section-BB**

Tests for Raw Materials, Non-critical Materials and Harness Materials etc.
(Inspection Reports Submission is not mandatory but adequate documentary evidence shall be available with the supplier to confirm the compliance to these tests)

I. HRS/CRCS Sheets & Strips:

- Visual Checks : For straightness, squareness, corrosion, surface Finish.
- Dimensional Checks : As per IS: 1852, IS: 513 & IS: 1079.
- Weldability : To see that welding can be done properly on the material, and free of cracks.
- Bend test : As per IS: 1599

II.Channels, Beams and Angles (HRS):

- Visual checks : For straightness, squareness, corrosion, surface finish.
- Dimensional checks : As per IS: 808
- Weight/meter : As per IS: 808
- Weldability : To see that welding on this material can be done properly or not and free of cracks.

III. Rods/Bars of Brass, Copper, Steel:

- Visual checks : Straightness, pinholes and other surface defects.
- Dimensional checks : As per IS:9550 and IS: 1501.

NUCLEAR POWER CORPORATION OF INDIA LIMITED	
TECHNICAL SPECIFICATION FOR REQUIREMENTS OF COMPONENTS/EQUIPMENT FOR INSTRUMENTATION ITEMS	PAGE No.:29 of 37 REV. No. : 1

**Annexure-B
Section-BB**

Tests for Raw Materials, Non-critical Materials and Harness Materials etc.
(Inspection Reports Submission is not mandatory but adequate documentary evidence shall be available with the supplier to confirm the compliance to these tests)

IV. Aluminum Sheets, Rods, Flats, Tubes, etc.:

Visual checks : Straightness, blowholes, pin holes and other surface defects.

Dimensional checks : As per IS: 3965 and IS: 2677.

V. Laminated sheets/Acrylic sheets/Nylon/Teflon/PVC Rods, etc.

Visual checks : For surface defects such as scratches, material cuts.

Dimensional checks : As per IS: 2036,

Thickness of coating : As per catalogue.
(in case of copper clad sheets)

Water absorption : As per IS: 1998
(in case of Thermosetting Synthetic Resin bonded laminated sheets)

Machining test : Checking the material for drilling, tapping and machining for obvious signs of splitting, cracks and chipping (in case of synthetic resin bonded laminated sheets)

Insulation test : As per IS: 2036 and flame-retardant test.

VI. PVC/Rubber, Gaskets, Grommets, Tubes and other products:

Visual checks : Material cuts and other surface defects.

Dimensional check : As per catalogue/drawings

Flame retardant test : As per IS: 694
(for PVC products)

NUCLEAR POWER CORPORATION OF INDIA LIMITED	
TECHNICAL SPECIFICATION FOR REQUIREMENTS OF COMPONENTS/EQUIPMENT FOR INSTRUMENTATION ITEMS	PAGE No.:30 of 37 REV. No. : 1

**Annexure-B
Section-BB**

Tests for Raw Materials, Non-critical Materials and Harness Materials etc.
(Inspection Reports Submission is not mandatory but adequate documentary evidence shall be available with the supplier to confirm the compliance to these tests)

VII. Knobs/PCB guides/ejectors:

- Visual checks : For casting and other surface defects
- Dimensional checks : As per catalogue/drawings
- Insulation resistance : As per catalogue
- Flame retardant : As per IS: 694

VIII. Hardware: Bolts, nuts, screws, washers, circlips, etc.

- Visual check : Burrs, material cuts, dents, rust.
 - Dimensional checks : As per BS: 57, BS: 1083, BS: 84, BS: 916, IS: 3082.
 - Threading : With corresponding std. Thread ring/plug gauges.
 - Twisting : As per IS: 3063
(for spring washers only)
- Functional (for Lock washers, self-tapping screws, circlips) with the mating parts.

IX. Harness materials like PVC channels, clamps, straps threads, etc.

- Visual checks : For material cuts and other surface defects.
- Dimensional check : As per catalogues

NUCLEAR POWER CORPORATION OF INDIA LIMITED	
TECHNICAL SPECIFICATION FOR REQUIREMENTS OF COMPONENTS/EQUIPMENT FOR INSTRUMENTATION ITEMS	PAGE No.:31 of 37 REV. No. : 1

**Annexure-B
Section-BB**

Tests for Raw Materials, Non-critical Materials and Harness Materials etc.
(Inspection Reports Submission is not mandatory but adequate documentary evidence shall be available with the supplier to confirm the compliance to these tests)

X. Plating of Components:

Visual check : For blistering, non-deposition, and passivation.

Adhesion : With the help of cellulose tape.

Adhesion of passivation: As per IS: 1572
(in case of cad plating with passivation)

Porosity : With 1% HCL
(for cad-plating only)

Thickness : With help of Minitester
(For cad plating, nickel plating, zinc plating, etc.)

XI. Space Heater:

Visual inspection : Type No., workmanship

Dimensional check : As per the catalogue

Functional check: 1) Current measurement at rated voltage (wattage)
2) Temperature measurement
3) Coil resistance measurement
4) Insulation resistance measurement

XII. Tube Lights, Incandescent Lamps, CFL lamps

Visual inspection : Type No., External damages, and suitability with Holder.

Dimensional check : Dimension as per the catalogue

Functional check : Current measurement at rated voltage.

NUCLEAR POWER CORPORATION OF INDIA LIMITED	
TECHNICAL SPECIFICATION FOR REQUIREMENTS OF COMPONENTS/EQUIPMENT FOR INSTRUMENTATION ITEMS	PAGE No.:32 of 37 REV. No. : 1

**Annexure-B
Section-BB**

Tests for Raw Materials, Non-critical Materials and Harness Materials, etc.
(Inspection Reports Submission is not mandatory but adequate documentary evidence shall be available with the supplier to confirm the compliance to these tests)

XIII. Locks and handles:

- Visual checks : Surface defects, type verification, etc.
- Dimensional checks : As per catalogue/drg. /std.
- Functional/operation : Closing and opening of the lock with the Keys supplied.
- Plating (for handles) : Adhesion, appearance

XIV. Power plugs sockets and switches:

- Visual inspection : Type No., external damages, mounting hardware, markings, workmanship.
- Dimensional checks : As per the catalogue
- Functional checks : 1) Mating with counterpart
(for plugs and sockets only)
- 2) Voltage proof test
- 3) Insulation resistance

NUCLEAR POWER CORPORATION OF INDIA LIMITED	
TECHNICAL SPECIFICATION FOR REQUIREMENTS OF COMPONENTS/EQUIPMENT FOR INSTRUMENTATION ITEMS	PAGE No.:33 of 37 REV. No. : 1

Annexure-C

Items for which source inspection is to be carried out along with NPCIL QS

Inspection shall be carried out as per Standard/approved QAP/ approved acceptance test procedure. Whenever QAP or standard is not applicable, test procedure is to be made and get it approved by NPCIL Designer.

S.No.	Device	Testing
1.	Personal computers	1) Configuration checks, Pre-Burn-in diagnostics, 168 hour Burn-in test, Post Burn-in diagnostics, Power supply variation test. (as per manufacturer's catalogue) for both Industrial and commercial grade. 2) Seismic, Climatic test and EMC tests as per relevant specification / Manufacturer's Catalogue for Industrial Grade PCs. 3) For Commercial Grade PCs Climatic test limited to 40 °C and 85% RH.
2.	Monitors	1) Pre-Burn-in function, Pixel defect check, 168 hour Burn-in test, Post Burn-in function, Pixel defect check, Power supply variation test. (as per manufacturer's catalogue) 2) Climatic test (limited to 40 °C and 85% RH) and EMC tests as per relevant specification / Manufacturer's Catalogue.
3.	Printers	Functional test, 168 hour Burn-in test, Functional test, Power supply variation test.(as per manufacturer's catalogue).
4.	PC Network interface cards	1) Pre-Burn-in Functional test, 168 hour Burn-in, Post Burn-in Functional test.
5.	Network Switches	2) Climatic and EMC tests as per relevant specification/ Manufacturer's Catalogue. 3) Seismic qualification to the extent of retaining structural integrity.
6.	Media converters	
7.	Modems	
8.	Add on boards/cards	
9.	Patch cords and Light interface units	Visual and Ping Checks
10.	Fiber optic cables	As per relevant IS/IEC

NUCLEAR POWER CORPORATION OF INDIA LIMITED	
TECHNICAL SPECIFICATION FOR REQUIREMENTS OF COMPONENTS/EQUIPMENT FOR INSTRUMENTATION ITEMS	PAGE No. : 34 of 37 REV. No. : 1

S.No.	Device	Testing
11.	Ethernet cables	As per relevant IS/IEC
12	Power supplies	1) Pre-Burn-in Functional test, Burn-in, Post Burn-in Functional test, 2) Climatic test, Seismic and EMC test as per relevant specification
13.	Signal conditioning modules	1) Pre-Burn-in Functional test, Burn-in, Post Burn-in Functional test, 2) Climatic test, Seismic and EMC test as per relevant specification
14.	Interface Modules (IFM)	As per NPCIL specification
15.	Power & Control Transformers	As per relevant IS
16.	CTs & PTs	As per relevant IS
17.	RF Coils, chokes, inductors	As per relevant IS
18.	Hybrid circuits	1) Functional test as per approved component specification. 2) Other tests as per relevant JSS
19.	Power & Control cables	As per relevant IS/JSS/MIL
20.	Video cable	As per relevant IS/JSS/MIL
21.	Blank PCBs	As per PP-E-1443
22.	Pneumatic components like Regulators, Valves, Fittings & Pressure Gauges, etc	As per approved specification
23.	Motors & Pumps	As per relevant IS/approved specification
24	Circuit Breakers	As per relevant IS
25	Miniature Circuit Breakers	As per relevant IS
26.	All sub-orders for manufactured items at approved sub-vendors.	As per approved specification

NUCLEAR POWER CORPORATION OF INDIA LIMITED	
TECHNICAL SPECIFICATION FOR REQUIREMENTS OF COMPONENTS/EQUIPMENT FOR INSTRUMENTATION ITEMS	PAGE No.:35 of 37 REV. No. : 1

Annexure-D

Proposal by supplier to NPCIL designer to use commercial grade components as per Annexure-A sec 1.2.b&1.3.b

Below mentioned text is to be typed on the letter head of the supplier.

“Following components are not available in MIL/Industrial grade are required to be used in the system. So we propose to use the components with screening.

Signature of Supplier

Above proposal is acceptable.

Signature of NPCIL Designer

Checked By:

Approved By:

NUCLEAR POWER CORPORATION OF INDIA LIMITED	
TECHNICAL SPECIFICATION FOR REQUIREMENTS OF COMPONENTS/EQUIPMENT FOR INSTRUMENTATION ITEMS	PAGE No.:36 of 37 REV. No. : 1

Annexure-E
Proposal by supplier to NPCIL designer to use components as per
Annexure-A sec 2.2 b.1

Below mentioned text is to be typed on the letter head of the supplier.

“Following components/items were used in earlier projects.....
and their performance is up-to the mark. So we propose to use these
components/items in also. Kindly approve the same.”

Signature of Supplier

Above proposal is acceptable.

Signature of NPCIL Designer

Checked By:

Approved By:

NUCLEAR POWER CORPORATION OF INDIA LIMITED	
TECHNICAL SPECIFICATION FOR REQUIREMENTS OF COMPONENTS/EQUIPMENT FOR INSTRUMENTATION ITEMS	PAGE No.:37 of 37 REV. No. : 1

Annexure-F

**Proposal by supplier to NPCIL designer to use components as per Annexure-A
sec 2.2.c**

Below mentioned text is to be typed on the letter head of the supplier.

“Following components/items are not available to meet Annexure-A Sec 2.2 a & b However they are required to be used to meet design requirements. So we propose to use these components/items after conducting below mentioned tests. Kindly approve the same.”

Signature of Supplier





Above proposal is acceptable.

Signature of NPCIL Designer

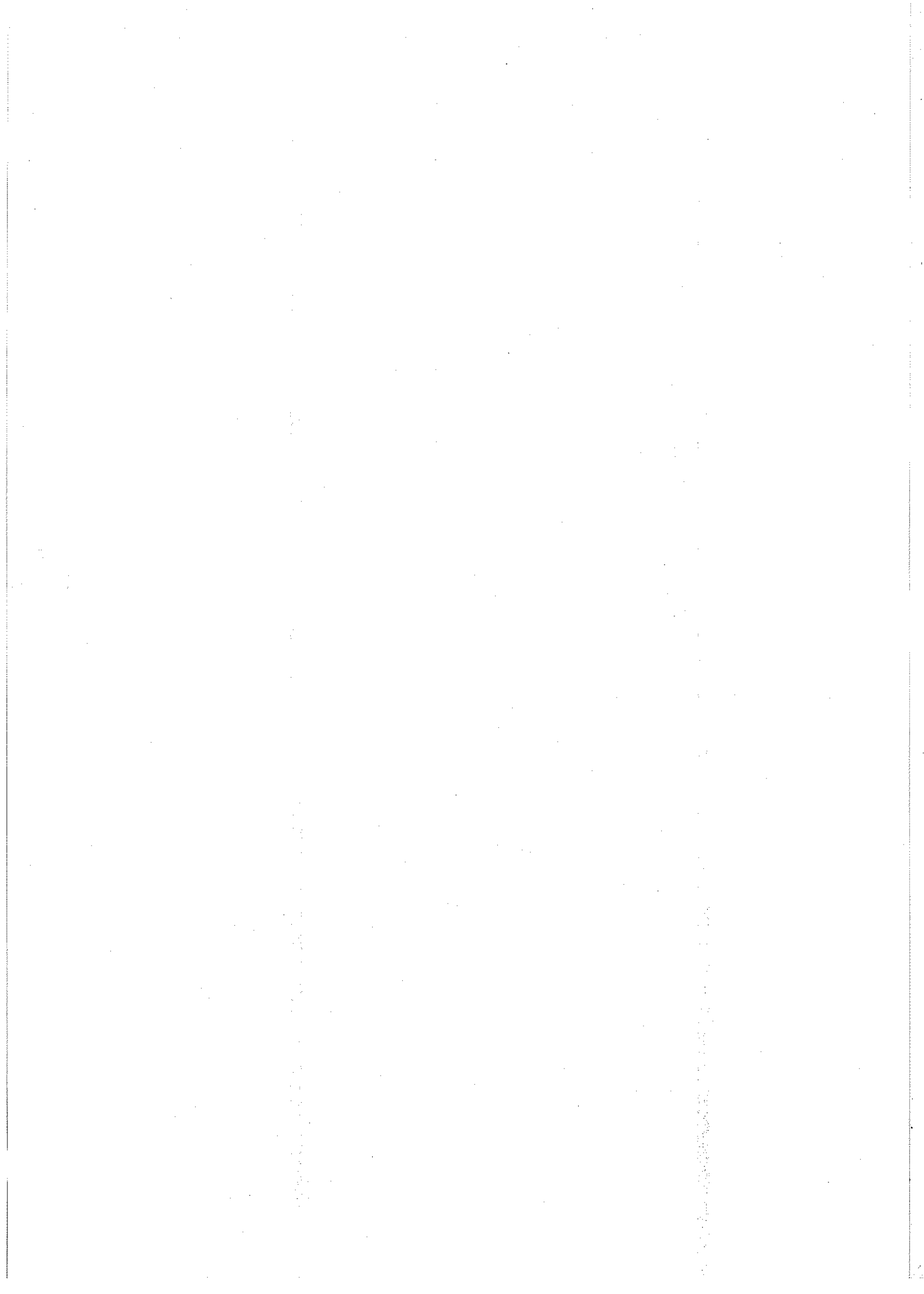
Checked By:

Approved By:

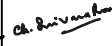





ISSUE NO.	REV. NO.	DATE	REVISIONS/ISSUES COVER SHEET	DES'D	DES. CHK'D	REV'D	APP'D
1	0		ISSUED FOR INFORMATION.	 6/19/2012	 6/19/2012	 6/19/2012	 6/29/2012

A4

REV.	0	0	0	0	0	0	0	0	0	0	0	0	0	0	0	0	0	0
SHT.	1	2	3	4	5	6	7	8	9	10	11	12	13	14	15	16	17	18

REV.	0	0																
SHT.	19	20																

3581/2012							NUCLEAR POWER CORPORATION OF INDIA LTD.	
I.S. No.	DR'N.	DES'D	D.CHK'D	REV'D	APP'D		(A GOVERNMENT OF INDIA ENTERPRISE)	
PROJECT	TITLE: RAJASTHAN ATOMIC POWER PROJECT-7 & 8					DRG. No.	RAPP-7&8/60427/2001/ES	
RAPP-7&8	ENGG. STANDARD FOR ESCUTCHEON PLATES AND HANDSWITCHES.							
						SHEET 1 OF 20		

NOTES







1.0 NOTES FOR ESCUTCHEON PLATES :

- 1.1 + FOR BREAKERS ONLY
- 1.2 * RESET TO BE ADDED IF THIS POSITION WILL CLEAR AN OVER LOAD OR NO VOLTAGE LOCK-OUT OTHERWISE OFF OR STOP IS SUFFICIENT
- 1.3 IN THE EVENT THAT ELEMENTARY DRAWING CONFLICTS WITH THE REQUIREMENT OF THIS STANDARD, THE REQUIREMENT OF THIS STANDARD SHALL GOVERN.

2.0 NOTES FOR HAND SWITCHES AND DISCREPANCY SWITCHES :

- 2.1 'X' DENOTES CONTACT IS CLOSED IN THAT POSITION. IN OTHER POSITIONS IT IS OPEN.
- 2.2 ALL CONTACTS ARE BREAK BEFORE MAKE UNLESS INDICATED OTHERWISE IN REMARKS COLUMN.
- 2.3 BLKD MEANS POSITION IS BLOCKED AND HANDSWITCH KNOB CANNOT BE MOVED TO THAT POSITION.
- 2.4 MISSING SERIAL NOS. OF HANDSWITCHES ARE NOT USED.
- 2.5 CONTACT RATING OF HAND SWITCHES AND DISCREPANCY SWITCHES IS 2 Amp AT 24V DC FOR INDUCTIVE LOADS OF L/R= 15 msec. UNLESS INDICATED OTHERWISE IN REMARKS COLUMN.

A4

3581/2012						 NUCLEAR POWER CORPORATION OF INDIA LTD. (A GOVERNMENT OF INDIA ENTERPRISE)
I.S. No.	DR'N.	DES'D	D.CHK'D	REV'D	APP'D	
PROJECT	TITLE: RAJASTHAN ATOMIC POWER PROJECT-7 & 8					DRG. No. RAPP-7&8/60427/2001/ES SHEET 2 OF 20
RAPP-7&8	ENGG. STANDARD FOR ESCUTCHEON PLATES AND HANDSWITCHES.					

Specification of Hand Switches

Type open execution (without enclosure)
 Mounting Suitable for flush mounting on mosaic grid
 Handle Black or Red colored knob with White arrow
 Panel Area 48mm x 48mm (max) including escutcheon plate
 No. of positions a) Four (90° angle between positions)
 position 1: 12'0 clock position position 3: 6'0 clock position
 position 2: 3'0 clock position position 4: 9'0 clock position
 b) For more than four positions supplier may suggest angle between positions
 Torque Requirement 3.5 kg cm (3 Lb inch)
 Contact Rating Thermal rating: 2 Amps
 Making & Breaking current of 2 Amp at 24V DC for inductive load of L/R= 15ms.
 Contact Resistance Less than 15 milliohms
 Contact Material Suitable for one millian operations
 Duty Continuous
 Insulation Resistance More than 1000 M Ohms at 500V DC
 Dielectric Strentht 2 KV RMS. 50Hz for one minute.
 Terminals Suitable for back panel wiring with lugs.
 Applicable Standards IEC: 408 - Low-Voltage Air-Break switches, Air-Break disconnectors, Air-Break switch disconnectors and fuse combination units.
 IEEE: 344 - Recommended practices for seismic qualification of Class-1E equipment for Nuclear Power Generating Station.
 IS: 6875 - Specification for control switches (switching devices including Contactor relays) for voltage upto & including 1000V AC & 1200V DC.
 IS: 4064 - Air break switches, air break disconnectors, air break switch disconnectors & fuse combination units for voltages not exceeding 1000 VAC or 1200VAC.
 JSS: 51208 - Detail specification for switches.

A4

Specification of Discrepancy Hand Switches

Type Discrepancy type with built- in LED lamp
 Mounting Suitable for flush mounting on mosaic grid
 Panel Area 48mm x 48mm (max) including escutcheon plate
 No. of position Four
 position 1(CC) : 12'0 clock position
 position 2(C) : 1'0 clock position
 position 3(T) : 8'0 clock position
 position 4(TT) : 9'0 clock position
 For tripping turn 90° from position 1 to position 4 and than press and turn to position 3. (Anti-clockwise)
 For closing turn 90° from position 4 to position 1 and than press and turn to position 2. (Clockwise)
 Contact Rating 2 Amp at 24V DC for Inductive Load of L/R = 15 ms.
 Contact Resistance Less than 15 milliohms
 Duty Continuous
 Insulation Resistance More than 1000 M Ohms at 500V DC
 Dielectric Strentht 2 KV RMS. 50Hz for one minute
 Mechanical Life 0.3 million operations

3581/2012						NUCLEAR POWER CORPORATION OF INDIA LTD. (A GOVERNMENT OF INDIA ENTERPRISE)
I.S. No.	DR'N.	DES'D	D.CHK'D	REV'D	APP'D	
	SIGNATURE & DATE					
PROJECT	TITLE: RAJASTHAN ATOMIC POWER PROJECT-7 & 8					DRG. No. RAPP-7&8/60427/2001/ES SHEET 3 OF 20
RAPP-7&8	ENGG. STANDARD FOR ESCUTCHEON PLATES AND HANDSWITCHES.					

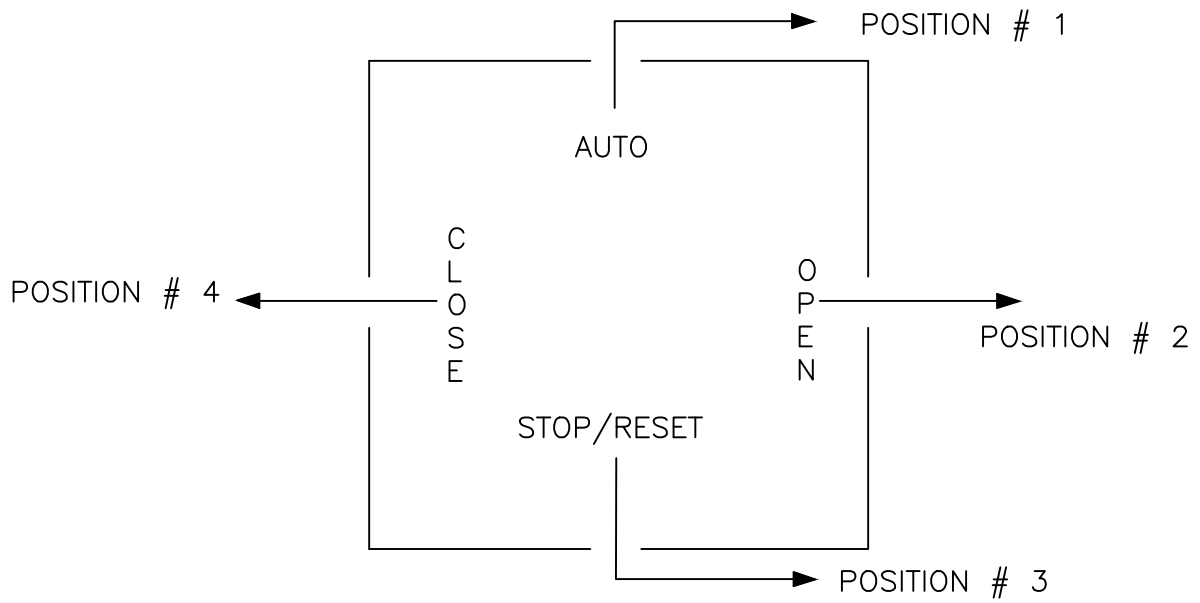

TYPICAL ESCUTCHEON PLATE FOR HAND SWITCH

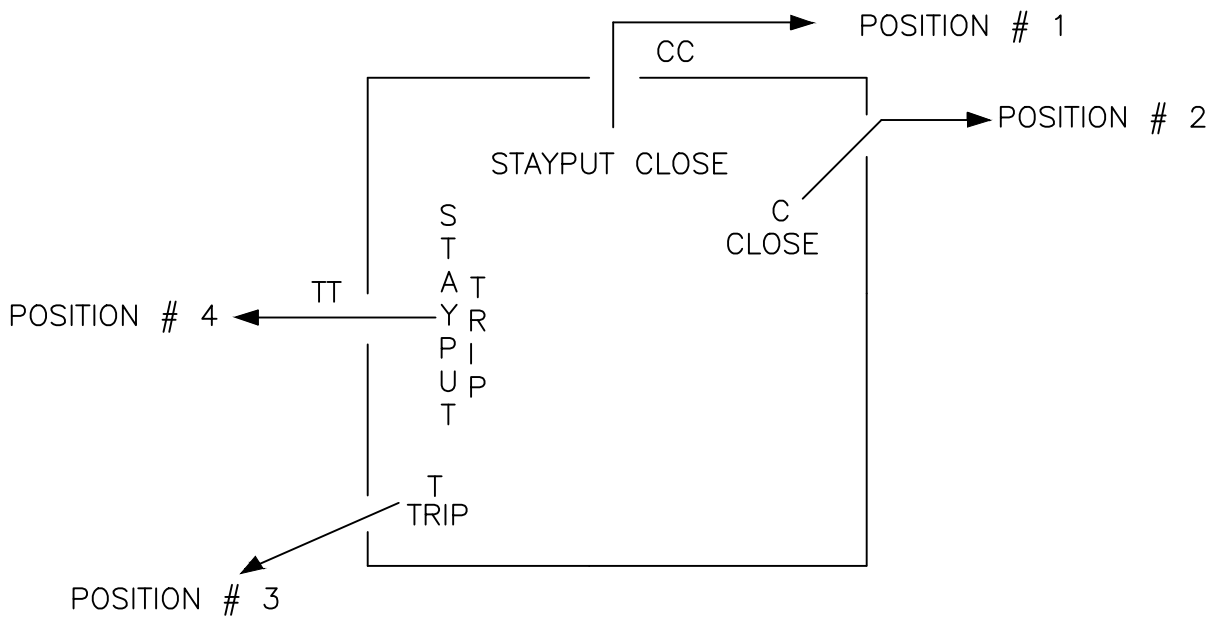

TYPICAL ESCUTCHEON PLATE FOR DISCREPANCY HAND SWITCH

A4

3581/2012	<i>[Signature]</i> 6/19/2012	<i>[Signature]</i> 6/19/2012	<i>[Signature]</i> 6/19/2012	<i>[Signature]</i> 6/29/2012	 NUCLEAR POWER CORPORATION OF INDIA LTD. (A GOVERNMENT OF INDIA ENTERPRISE)	
I.S. No.	DR'N.	DES'D	D.CHK'D	REV'D		APP'D
PROJECT	TITLE: RAJASTHAN ATOMIC POWER PROJECT-7 & 8				DRG. No.	REV.No.0
RAPP-7&8	ENGG. STANDARD FOR ESCUTCHEON PLATES AND HANDSWITCHES.				RAPP-7&8/60427/2001/ES	SCALE-N.T.S
					SHEET 4 OF 20	

ENGRAVING DETAILS OF ESCUTCHEON PLATES

TYPE NO.	POSITION # 1	POSITION # 2	POSITION # 3	POSITION # 4
1	OPEN			CLOSE
2	AUTO			CLOSE
3	ON			OFF/RESET *
4	AUTO			OFF/RESET *
5	AUTO	ON		
6	AUTO			MANUAL
7	REMOTE			LOCAL
8	IN			OUT
9	UP			DOWN
10+	CLOSE			TRIP
11	RAISE			LOWER
12	ENGAGED			RELEASED
13	NORMAL	BANK 2		BANK-1
14	ON			BLOCK
15	NORMAL	UNLOCK		
16	NORMAL	RESET		
17	NORMAL	ACKNOWLEDGE		
18	OPEN	ISOLATE		
19	AUTO	ISOLATE		
20	AUTO	OPEN		
21	NORMAL	BY PASS		
22	INLET			OUTLET
23	NORMAL	PURGE		
24	NORMAL	DELATCH		
25	NORMAL	OVERRIDE OPEN		
26	MANUAL			OFF
27	AUTO	VENT		
28	OVERRIDE			CLOSE
29	NORMAL	ISOLATE		
30	AUTO	OPEN		CLOSE
31	AUTO	ON		OFF/RESET
32	STOP/RESET *	OPEN		CLOSE
33	STAND BY	ON		OFF/RESET *
34	STOP/RESET*	RAISE		LOWER
35	STOP/RESET*	OUT		IN
36	STOP/RESET*	UP		DOWN
37	AUTO	OPEN		STOP
38	AUTO	START		OFF
39	HOLD	OUT		IN
40	NORMAL	OPEN		CLOSE
41	AUTO	DRAIN		FILL
42	AUTO	POS		NEG







A4

3581/2012	<i>[Signature]</i> 6/19/2012	<i>[Signature]</i> 6/19/2012	<i>[Signature]</i> 6/19/2012	<i>[Signature]</i> 6/29/2012	 NUCLEAR POWER CORPORATION OF INDIA LTD. (A GOVERNMENT OF INDIA ENTERPRISE)	
I.S. No.	DR'N.	DES'D	D.CHK'D	REV'D		APP'D
PROJECT RAPP-7&8	TITLE: RAJASTHAN ATOMIC POWER PROJECT-7 & 8 ENGG. STANDARD FOR ESCUTCHEON PLATES AND HANDSWITCHES.				DRG. No. RAPP-7&8/60427/2001/ES	REV No. 0 SCALE-N.T.S
						SHEET 5 OF 20

ENGRAVING DETAILS OF ESCUTCHEON PLATES

TYPE NO.	POSITION # 1	POSITION # 2	POSITION # 3	POSITION # 4
43	OFF/STOP	AUTO		MANUAL
44	NORMAL	SPRAYS ON		RESET
45	STOP/RESET *	AUTO		CLOSE
46	MANUAL	AUTO		AUTO PR
47	PL-3	PL-7		PL-2
48	OVER RIDE			OFF
49	UNIT-1	UNIT-2		OFF
50	OFF/STOP	RAISE		LOWER
51	RY	YB		BR
52	NORMAL	RAISE		LOWER
53	AUTO	DRAIN TANK		OFF
54	ADD	OFF		
55	ON#1	ON # 2		OFF
56	NORMAL/AUTO	TEST OUT		SUT
57	NORMAL	FAST START		
58	LOWER	HOLD		
59	TIME RAISED	MAIN RAISE/ TIMER RESET		
60	LE	US	UNE	USW
61	AUTO	OPEN	STOP/RESET	CLOSE
62	STOP/AUTO	OPEN		CLOSE
63	RESET	AUTO/OPEN		CLOSE
64	STOP/RESET			CLOSE-A
65	LSE	UNW	N	UE
66	LNW	USE		UW
67	NORMAL	GROUP 2		GROUP-1
68	GR # 1	GR # 2	GR # 3	GR # 4
69	UNE	LSW	S	LE
70	IXVENT	OPEN		CLOSE
71	INSTLN # 1	INSTLN # 2		
72	LE	UNE	S	LSW
73	AUTO	HTR IN SRV	HTR IN BYPS	MANUAL
74	AUTO	MAIN		STDBY
75	MCR	BCR		
76	OWS	OPEN		CLOSE
77	OWS	EXT. MAN		
78	OWS	ON		OFF-RESET
79	OWS	OFF		ON
80	OWS			CLOSE
81	OWS	STOP-RESET		CLOSE
82	OWS			OFF-RESET
83	OWS	LOCAL		

A4

3581/2012						 NUCLEAR POWER CORPORATION OF INDIA LTD. (A GOVERNMENT OF INDIA ENTERPRISE)	
I.S. No.	DR'N.	DES'D	D.CHK'D	REV'D	APP'D		
PROJECT RAPP-7&8	TITLE: RAJASTHAN ATOMIC POWER PROJECT-7 & 8 ENGG. STANDARD FOR ESCUTCHEON PLATES AND HANDSWITCHES.					DRG. No. RAPP-7&8/60427/2001/ES	REV No.0 SCALE-N.T.S
						SHEET 6 OF 20	

TYPES OF HAND SWITCHES

SL. NO.	POLES	POSITION # 1	POSITION # 2	POSITION # 3	POSITION # 4	REMARKS
1	1 - 2	X		BLKD	BLKD	
	3 - 4	X		BLKD	BLKD	
	5 - 6		X	BLKD	BLKD	
	7 - 8		X	BLKD	BLKD	
3	1 - 2	X		BLKD	BLKD	SPRING RETURN TO POS 1 FROM POS 2
	3 - 4	X		BLKD	BLKD	
	5 - 6		X	BLKD	BLKD	
	7 - 8		X	BLKD	BLKD	
4	1 - 2	X	BLKD	BLKD		
	3 - 4	X	BLKD	BLKD		
	5 - 6		BLKD	BLKD	X	
	7 - 8		BLKD	BLKD	X	
5	1 - 2		X	BLKD		SPRING RETURN TO POS 1 FROM POS 4 & POS 2
	3 - 4		X	BLKD		
	5 - 6			BLKD	X	
	7 - 8			BLKD	X	
9	1 - 2	X		BLKD		
	3 - 4	X		BLKD		
	5 - 6		X	BLKD		
	7 - 8		X	BLKD		
	9 - 10			BLKD	X	
	11 - 12			BLKD	X	
20	1 - 2	X	BLKD	BLKD		
	3 - 4	X	BLKD	BLKD		
	5 - 6	X	BLKD	BLKD		
	7 - 8	X	BLKD	BLKD		
	9 - 10		BLKD	BLKD	X	
	11 - 12		BLKD	BLKD	X	
	13 - 14		BLKD	BLKD	X	
	15 - 16		BLKD	BLKD	X	
23	1 - 2		X	BLKD		MBB (1-2 - 3-4)
	3 - 4	X		BLKD		
	5 - 6		X	BLKD		MBB (5-6 - 7-8)
	7 - 8	X		BLKD		
	9 - 10	X	X	BLKD		
	11 - 12	X	X	BLKD		
	13 - 14		X	BLKD		
	15 - 16	X		BLKD		
	17 - 18			BLKD	X	

A4

3581/2012	<i>[Signature]</i> 6/19/2012	<i>[Signature]</i> 6/19/2012	<i>[Signature]</i> 6/19/2012	<i>[Signature]</i> 6/29/2012	 NUCLEAR POWER CORPORATION OF INDIA LTD. (A GOVERNMENT OF INDIA ENTERPRISE)	
I.S. No.	DR'N.	DES'D	D.CHK'D	REV'D	APP'D	
	SIGNATURE & DATE					
PROJECT	TITLE: RAJASTHAN ATOMIC POWER PROJECT-7 & 8				DRG. No.	REV No.0
RAPP-7&8	ENGG. STANDARD FOR ESCUTCHEON PLATES AND HANDSWITCHES.				RAPP-7&8/60427/2001/ES	SCALE-N.T.S
					SHEET 7 OF 20	

TYPES OF HAND SWITCHES

SL. NO.	POLES	POSITION # 1	POSITION # 2	POSITION # 3	POSITION # 4	REMARKS
24	1 - 2	X				MBB (1-2 - 3-4)
	3 - 4		X			
	5 - 6			X		MBB (5-6 - 7-8)
	7 - 8				X	
	9 - 10	X				MBB (9-10 - 11-12)
	11 - 12		X			
	13 - 14				X	MBB (13-14 - 15-16)
	15 - 16				X	
	17 - 18				X	
26	1 - 2		X	BLKD		MBB (1-2) - (3-4)
	3 - 4	X		BLKD		
	5 - 6		X	BLKD		MBB (5-6) - (7-8)
	7 - 8	X		BLKD		
	9 - 10			BLKD	X	
	11 - 12	X	X	BLKD		
	13 - 14			BLKD	X	
	15 - 16	X	X	BLKD		
	17 - 18	X	X	BLKD		
SL. NO.	POLES	POSITION # 1 CC	POSITION # 2 C	POSITION # 3 T	POSITION # 4 TT	REMARKS
27 DISCREPANCY HAND SWITCH	1 - 2		X			1)SPRING RETURN TO POS 1 FROM POS 2 2) SPRING RETURN TO POSN 4 FROM POSN 3.
	3 - 4			X		
	5 - 6		X			
	7 - 8		X			
	9 - 10				X	
	11 - 12				X	
	13 - 14	X	X			
	15 - 16				X	
SL. NO.	POLES	POSITION # 1	POSITION # 2	POSITION # 3	POSITION # 4	REMARKS
28	1 - 2			BLKD	X	SPRING RETURN TO POS 1 FROM POS 2 & 4.
	3 - 4		X	BLKD		
	5 - 6			BLKD	X	
	7 - 8		X	BLKD		
	9 - 10			BLKD	X	
	11 - 12		X	BLKD		
	13 - 14	X		BLKD		
	15 - 16	X		BLKD		
	17 - 18	X		BLKD		
31	1 - 2	X		BLKD	BLKD	
	3 - 4	X		BLKD	BLKD	
	5 - 6	X		BLKD	BLKD	
	7 - 8	X		BLKD	BLKD	
	9 - 10	X		BLKD	BLKD	
	11 - 12		X	BLKD	BLKD	
	13 - 14		X	BLKD	BLKD	
	15 - 16		X	BLKD	BLKD	
	17 - 18		X	BLKD	BLKD	
	19 - 20		X	BLKD	BLKD	







A4

3581/2012						NUCLEAR POWER CORPORATION OF INDIA LIMITED (A GOVERNMENT OF INDIA ENTERPRISE)
I.S. No.	DR'N.	DES'D	D.CHK'D	REV'D	APP'D	
SIGNATURE & DATE						DRG. No. RAPP-7&8/60427/2001/ES Sheet 8 of 20
PROJECT	TITLE:					
RAPP-7&8	RAJASTHAN ATOMIC POWER PROJECT-7&8 ENGG STANDARD FOR ESCUTCHEON PLATES AND HANDSWITCHES.					SCALE-NTS

TYPES OF HAND SWITCHES

SL. NO.	POLES	POSITION # 1	POSITION # 2	POSITION # 3	POSITION # 4	REMARKS
32	1 - 2		BLKD	BLKD	X	
	3 - 4	X	BLKD	BLKD		
	5 - 6		BLKD	BLKD	X	
	7 - 8	X	BLKD	BLKD		
	9 - 10		BLKD	BLKD	X	
	11 - 12	X	BLKD	BLKD		
	13 - 14		BLKD	BLKD	X	
	15 - 16	X	BLKD	BLKD		
	17 - 18		BLKD	BLKD	X	
35	1 - 2		X			
	3 - 4	X				
	5 - 6				X	
	7 - 8	X				
	9 - 10	X				
	11 - 12	X	X		X	
	13 - 14			X		
	15 - 16		X			
	17 - 18	X				
	19 - 20				X	
38	1 - 2	X		BLKD		
	3 - 4	X		BLKD		
	5 - 6	X		BLKD		
	7 - 8	X		BLKD		
	9 - 10		X	BLKD		
	11 - 12		X	BLKD		
	13 - 14		X	BLKD		
	15 - 16		X	BLKD		
	17 - 18			BLKD	X	
	19 - 20			BLKD	X	
	21 - 22			BLKD	X	
39	1 - 2	X		BLKD		CONTACT RATING 12 Amp AT 220V DC FOR INDUCTIVE LOAD OF L/R =7.5m sec.
	3 - 4	X		BLKD		
	5 - 6	X		BLKD		
	7 - 8	X		BLKD		
	9 - 10		X	BLKD		
	11 - 12		X	BLKD		
	13 - 14			BLKD	X	
	15 - 16			BLKD	X	







A4

3581/2012						 NUCLEAR POWER CORPORATION OF INDIA LTD. (A GOVERNMENT OF INDIA ENTERPRISE)	
I.S. No.	DR'N.	DES'D	D.CHK'D	REV'D	APP'D		
PROJECT	TITLE: RAJASTHAN ATOMIC POWER PROJECT-7 & 8					DRG. No. RAPP-7&8/60427/2001/ES	REV. No.0
RAPP-7&8	ENGG. STANDARD FOR ESCUTCHEON PLATES AND HANDSWITCHES.						SHEET 9 OF 20

TYPES OF HAND SWITCHES

SL. NO.	POLES	POSITION # 1	POSITION # 2	POSITION # 3	POSITION # 4	REMARKS
45	1 - 2	X		BLKD	BLKD ^X	
	3 - 4	X		BLKD	BLKD	
	5 - 6	X		BLKD	BLKD	
	7 - 8	X		BLKD	BLKD	
	9 - 10	X		BLKD	BLKD	
	11 - 12	X		BLKD	BLKD	
	13 - 14	X		BLKD	BLKD	
	15 - 16	X		BLKD	BLKD	
	17 - 18	X		BLKD	BLKD	
	19 - 20	X		BLKD	BLKD	
	21 - 22	X		BLKD	BLKD	
	23 - 24	X		BLKD	BLKD	
	25 - 26	X		BLKD	BLKD	
47	1 - 2		X	BLKD		MBB (1-2) - (3-4)
	3 - 4	X		BLKD		
	5 - 6		X	BLKD		MBB (5-6) - (7-8)
	7 - 8	X		BLKD		
	9 - 10			BLKD	X	
	11 - 12	X	X	BLKD		
	13 - 14			BLKD	X	
	15 - 16	X	X	BLKD		
	17 - 18			BLKD	X	
	19 - 20			BLKD	X	
	21 - 22			BLKD	X	
23 - 24		X	BLKD			
25 - 26	X		BLKD			
56	1 - 2		X	BLKD	BLKD	SPRING RETURN TO POS 1 FROM POS 2
	3 - 4		X	BLKD	BLKD	
	5 - 6		X	BLKD	BLKD	
	7 - 8		X	BLKD	BLKD	
	9 - 10		X	BLKD	BLKD	
	11 - 12		X	BLKD	BLKD	
	13 - 14		X	BLKD	BLKD	
	15 - 16		X	BLKD	BLKD	
	17 - 18		X	BLKD	BLKD	
	19 - 20		X	BLKD	BLKD	
	21 - 22		X	BLKD	BLKD	
	23 - 24		X	BLKD	BLKD	
	25 - 26	X		BLKD	BLKD	







A4

3581/2012						 NUCLEAR POWER CORPORATION OF INDIA LTD. (A GOVERNMENT OF INDIA ENTERPRISE)	
I.S. No.	DR'N.	DES'D	D.CHK'D	REV'D	APP'D		
PROJECT RAPP-7&8	TITLE: RAJASTHAN ATOMIC POWER PROJECT-7 & 8 ENGG. STANDARD FOR ESCUTCHEON PLATES AND HANDSWITCHES.					DRG. No. RAPP-7&8/60427/2001/ES	REV. No.0 SCALE-N.T.S
							SHEET 10 OF 20

TYPES OF HAND SWITCHES

SL. NO.	POLES	POSITION # 1	POSITION # 2	POSITION # 3	POSITION # 4	REMARKS
68	1 - 2		X	BLKD		SPRING RETURN TO POSN 1 FROM POSN 2 &4
	3 - 4		X	BLKD		
	5 - 6		X	BLKD		
	7 - 8	X		BLKD		
	9 - 10	X		BLKD		
	11 - 12			BLKD	X	
	13 - 14			BLKD	X	
15 - 16			BLKD	X		
71	1 - 2		X	BLKD		
	3 - 4			BLKD	X	
	5 - 6	X		BLKD		
	7 - 8		X	BLKD		
	9 - 10			BLKD	X	
	11 - 12	X		BLKD		
	13 - 14		X	BLKD		
	15 - 16			BLKD	X	
	17 - 18	X		BLKD		
	19 - 20		X	BLKD		
	21 - 22			BLKD	X	
	23 - 24	X		BLKD		
	25 - 26		X	BLKD		
	27 - 28			BLKD	X	
	29 - 30	X		BLKD		
31 - 32		X	BLKD			
33 - 34			BLKD	X		
35 - 36	X		BLKD			







A4

3581/2012						 NUCLEAR POWER CORPORATION OF INDIA LTD. (A GOVERNMENT OF INDIA ENTERPRISE)	
I.S. No.	DR'N.	DES'D	D.CHK'D	REV'D	APP'D		
PROJECT RAPP-7&8	TITLE: RAJASTHAN ATOMIC POWER PROJECT-7 & 8 ENGG. STANDARD FOR ESCUTCHEON PLATES AND HANDSWITCHES.					DRG. No. RAPP-7&8/60427/2001/ES	REV No. 0
						SHEET 11 OF 20	SCALE-N.T.S

TYPES OF HAND SWITCHES

SL. NO.	POLES	POSITION # 1	POSITION # 2	POSITION # 3	POSITION # 4	REMARKS
73	1 - 2				X	
	3 - 4	X				
	5 - 6		X			
	7 - 8			X		
	9 - 10				X	
	11 - 12	X				
	13 - 14		X			
	15 - 16			X		
80	1 - 2		X	BLKD	BLKD	
	3 - 4		X	BLKD	BLKD	
	5 - 6		X	BLKD	BLKD	
	7 - 8		X	BLKD	BLKD	
	9 - 10		X	BLKD	BLKD	
	11 - 12		X	BLKD	BLKD	
	13 - 14		X	BLKD	BLKD	
	15 - 16		X	BLKD	BLKD	
	17 - 18		X	BLKD	BLKD	
	19 - 20		X	BLKD	BLKD	
	21 - 22	X		BLKD	BLKD	
	23 - 24	X		BLKD	BLKD	
	25 - 26		X	BLKD	BLKD	
	27 - 28	X		BLKD	BLKD	
	29 - 30	X		BLKD	BLKD	
31 - 32	X		BLKD	BLKD		

A4

3581/2012						 NUCLEAR POWER CORPORATION OF INDIA LTD. (A GOVERNMENT OF INDIA ENTERPRISE)	
I.S. No.	DR'N.	DES'D	D.CHK'D	REV'D	APP'D		
PROJECT RAPP-7&8	SIGNATURE & DATE					DRG. No. RAPP-7&8/60427/2001/ES SHEET 12 OF 20	REV No. 0
	TITLE: RAJASTHAN ATOMIC POWER PROJECT-7 & 8 ENGG. STANDARD FOR ESCUTCHEON PLATES AND HANDSWITCHES.						SCALE-N.T.S

TYPES OF HAND SWITCHES

SL. NO.	POLES	POSITION # 1	POSITION # 2	POSITION # 3	POSITION # 4	REMARKS					
92	1-2				X	MBB (1-2 - 3-4)					
	3-4	X									
	5-6		X								
	7-8			X							
	9-10				X						
	11-12	X									
	13-14		X								
	15-16			X							
SL. NO.	POLES	POS 1	POS 2	POS 3	POS 4	POS 5	POS 6	POS 7	POS 8	POS 9	REMARKS
93	1-2	X									
	3-4	X									
	5-6		X								
	7-8		X								
	9-10			X							
	11-12			X							
	13-14				X						
	15-16				X						
	17-18					X					
	19-20					X					
	21-22						X				
	23-24						X				
	25-26							X			
	27-28							X			
	29-30								X		
	31-32								X		
33-34									X		
35-36									X		

A4

3581/2012	<i>[Signature]</i>	<i>[Signature]</i>	<i>[Signature]</i>	<i>[Signature]</i>	<i>[Signature]</i>	 NUCLEAR POWER CORPORATION OF INDIA LTD. (A GOVERNMENT OF INDIA ENTERPRISE)	
I.S. No.	DR'N.	DES'D	D.CHK'D	REV'D	APP'D		
PROJECT	TITLE: RAJASTHAN ATOMIC POWER PROJECT-7 & 8					DRG. No. RAPP-7&8/60427/2001/ES	REV No.0
RAPP-7&8	ENGG. STANDARD FOR ESCUTCHEON PLATES AND HANDSWITCHES.						SHEET 13 OF 20

TYPES OF HAND SWITCHES

SL. NO.	POLES	POSITION # 1	POSITION # 2	POSITION # 3	POSITION # 4	REMARKS	
94	1-2	X					
	3-4	X					
	5-6	X					
	7-8	X					
	9-10	X					
	11-12	X					
	13-14	X					
	15-16	X					
	17-18			X			
	19-20			X			
	21-22			X			
	23-24			X			
	25-26			X			
	27-28			X			
	29-30			X			
	31-32			X			
	33-34				X		
	35-36				X		
	37-38				X		
	39-40				X		
	41-42				X		
	43-44				X		
	45-46				X		
	47-48				X		
	49-50						X
	51-52						X
	53-54						X
	55-56						X
	57-58						X
	59-60						X
	61-62						X
	63-64						X
95	1-2	X		BLKD		1.SPRING RETURN TO POSN 1 FROM POSN 4 2. POSN 1 & POSN 2 ARE STAYPUT	
	3-4	X		BLKD			
	5-6	X		BLKD			
	7-8	X		BLKD			
	9-10			X	BLKD		
	11-12			X	BLKD		
	13-14			X	BLKD		
	15-16			X	BLKD		
	17-18				BLKD		X
	19-20				BLKD		X
	21-22				BLKD		X
	23-24				BLKD		X

A4

3581/2012						NUCLEAR POWER CORPORATION OF INDIA LTD. (A GOVERNMENT OF INDIA ENTERPRISE)	
I.S. No.	DR'N.	DES'D	D.CHK'D	REV'D	APP'D		
PROJECT	TITLE: RAJASTHAN ATOMIC POWER PROJECT-7 & 8					DRG. No. RAPP-7&8/60427/2001/ES	REV No.0
RAPP-7&8	ENGG. STANDARD FOR ESCUTCHEON PLATES AND HANDSWITCHES.						SHEET 14 OF 20

TYPES OF HAND SWITCHES

SL. NO.	POLES	POSITION # 1	POSITION # 2	POSITION # 3	POSITION # 4	REMARKS		
96	1A	X	BLKD	BLKD		KEY WITH DRAWAL IN BOTH THE POSITIONS. ALL STAYPUT POSITIONS		
	2B	X	BLKD	BLKD				
	3C		BLKD	BLKD	X			
	4D		BLKD	BLKD	X			
SL. NO.	POLES	POS 1	POS 2	POS 3	POS 4	POS 5	REMARKS	
97	1-2	X						
	3-4		X					
	5-6			X				
	7-8				X			
	9-10					X		
	11-12	X						
	13-14		X					
	15-16			X				
	17-18				X			
19-20					X			
SL. NO.	POLES	POS 1	POS 2	POS 3	POS 4	POS 5	POS 6	REMARKS
98	1 - 2	X						
	3 - 4		X					
	5 - 6			X				
	7 - 8				X			
	9 - 10					X		
	11 - 12						X	
SL. NO.	POLES	POSITION #1	POSITION #2	POSITION #3	POSITION #4	REMARKS		
99	1 - 2		X		BLKD	MBB (1-2) - (3-4) MBB (5-6) - (7-8)		
	3 - 4	X			BLKD			
	5 - 6		X		BLKD			
	7 - 8	X			BLKD			
	9 - 10			X	BLKD			
	11 - 12	X	X		BLKD			
	13 - 14			X	BLKD			
	15 - 16	X	X		BLKD			
	17 - 18			X	BLKD			
	19 - 20			X	BLKD			
	21 - 22			X	BLKD			
	23 - 24		X		BLKD			
25 - 26	X			BLKD				







A4

3581/2012						NUCLEAR POWER CORPORATION OF INDIA LTD. (A GOVERNMENT OF INDIA ENTERPRISE)	
I.S. No.	DR'N.	DES'D	D.CHK'D	REV'D	APP'D		
PROJECT	TITLE: RAJASTHAN ATOMIC POWER PROJECT-7 & 8					DRG. No. RAPP-7&8/60427/2001/ES	REV No.0
RAPP-7&8	ENGG. STANDARD FOR ESCUTCHEON PLATES AND HANDSWITCHES.						SHEET 15 OF 20

TYPES OF HAND SWITCHES

SL. NO.	POLES	POS 1	POS 2	POS 3	POS 4	REMARKS
100	1-2		X	BLKD		MBB (1-2) - (3-4) MBB (5-6) - (7-8) MBB (9-10) - (11-12) MBB (13-14) - (15-16)
	3-4	X		BLKD		
	5-6		X	BLKD		
	7-8	X		BLKD		
	9-10		X	BLKD		
	11-12	X		BLKD		
	13-14		X	BLKD		
	15-16	X		BLKD		
17-18			BLKD	X		
101	1 - 2	X	BLKD	BLKD		
	3 - 4	X	BLKD	BLKD		
	5 - 6	X	BLKD	BLKD		
	7 - 8	X	BLKD	BLKD		
	9 - 10	X	BLKD	BLKD		
	11 - 12	X	BLKD	BLKD		
	13 - 14	X	BLKD	BLKD		
	15 - 16	X	BLKD	BLKD		
	17 - 18	X	BLKD	BLKD		
	19 - 20	X	BLKD	BLKD		
	21 - 22	X	BLKD	BLKD		
	23 - 24	X	BLKD	BLKD		
	25 - 26	X	BLKD	BLKD		
	27 - 28	X	BLKD	BLKD		
29 - 30	X	BLKD	BLKD			
31 - 32	X	BLKD	BLKD			
106	1 - 2		X	BLKD		
	3 - 4		X	BLKD		
	5 - 6		X	BLKD		
	7 - 8			BLKD	X	
	9 - 10			BLKD	X	
	11 - 12			BLKD	X	
	13 - 14	X		BLKD		
	15 - 16	X		BLKD		
	17 - 18	X		BLKD		
	19 - 20	X		BLKD		
	21 - 22	X		BLKD		
	23 - 24	X		BLKD		

A4

3581/2012						 NUCLEAR POWER CORPORATION OF INDIA LTD. (A GOVERNMENT OF INDIA ENTERPRISE)	
I.S. No.	DR'N.	DES'D	D.CHK'D	REV'D	APP'D		
PROJECT RAPP-7&8	SIGNATURE & DATE					DRG. No. RAPP-7&8/60427/2001/ES SHEET 16 OF 20	REV No.0
	TITLE: RAJASTHAN ATOMIC POWER PROJECT-7 & 8 ENGG. STANDARD FOR ESCUTCHEON PLATES AND HANDSWITCHES.						SCALE-N.T.S

TYPES OF HAND SWITCHES

SL. NO.	POLES	POS 1	POS 2	POS 3	POS 4	POS 5	POS 6	POS 7	POS 8	POS 9	POS10	POS11	POS12	REMARKS
107	1-2	X												
	3-4	X												
	5-6	X												
	7-8			X										
	9-10			X										
	11-12			X										
	13-14				X									
	15-16				X									
	17-18				X									
	19-20					X								
	21-22					X								
	23-24					X								
	25-26						X							
	27-28						X							
	29-30						X							
	31-32							X						
	33-34							X						
	35-36							X						
	37-38								X					
	39-40								X					
	41-42								X					
	43-44									X				
	45-46									X				
	47-48									X				
	49-50										X			
	51-52										X			
	53-54										X			
	55-56											X		
	57-58											X		
	59-60											X		
	61-62												X	
63-64												X		
65-66												X		
67-68													X	
69-70													X	
71-72													X	

A4

3581/2012	<i>[Signature]</i> 6/19/2012	<i>[Signature]</i> 6/19/2012	<i>[Signature]</i> 6/19/2012	<i>[Signature]</i> 6/29/2012	 NUCLEAR POWER CORPORATION OF INDIA LTD. (A GOVERNMENT OF INDIA ENTERPRRISE)	
I.S. No.	DR'N.	DES'D	D.CHK'D	REV'D	APP'D	
SIGNATURE & DATE						
PROJECT	TITLE: RAJASTHAN ATOMIC POWER PROJECT-7 & 8				DRG. No.	REV No.0
RAPP-7&8	ENGG. STANDARD FOR ESCUTCHEON PLATES AND HANDSWITCHES.				RAPP-7&8/60427/2001/ES	SCALE-N.T.S
						SHEET 17 OF 20

TYPES OF HAND SWITCHES

SL. NO.	POLES	POS 1	POS 2	POS 3	POS 4	REMARKS	
108	1 - 2	X	BLKD	BLKD			
	3 - 4	X	BLKD	BLKD			
	5 - 6	X	BLKD	BLKD			
	7 - 8	X	BLKD	BLKD			
	9 - 10	X	BLKD	BLKD			
	11 - 12	X	BLKD	BLKD			
	13 - 14	X	BLKD	BLKD			
	15 - 16	X	BLKD	BLKD			
	17 - 18	X	BLKD	BLKD			
	19 - 20	X	BLKD	BLKD			
	21 - 22	X	BLKD	BLKD			
	23 - 24	X	BLKD	BLKD			
	25 - 26	X	BLKD	BLKD			
	27 - 28	X	BLKD	BLKD			
	29 - 30			BLKD	BLKD	X	
	31 - 32			BLKD	BLKD	X	
	33 - 34			BLKD	BLKD	X	
35 - 36			BLKD	BLKD	X		
37 - 38			BLKD	BLKD	X		

SL. NO.	POLES	POS 1	POS 2	POS 3	POS 4	POS 5	POS 6	REMARKS
109	1 - 2	X						
	3 - 4	X						
	5 - 6	X						
	7 - 8			X				
	9 - 10			X				
	11 - 12			X				
	13 - 14				X			
	15 - 16				X			
	17 - 18				X			
	19 - 20					X		
	21 - 22					X		
	23 - 24					X		
	25 - 26						X	
	27 - 28						X	
	29 - 30						X	
31 - 32							X	
33 - 34							X	
35 - 36							X	

A4

3581/2012	<i>[Signature]</i> 6/19/2012	<i>[Signature]</i> 6/19/2012	<i>[Signature]</i> 6/19/2012	<i>[Signature]</i> 6/29/2012	 NUCLEAR POWER CORPORATION OF INDIA LTD. (A GOVERNMENT OF INDIA ENTERPRISE)
I.S. No.	SIGNATURE & DATE				
PROJECT RAPP-7&8	TITLE: RAJASTHAN ATOMIC POWER PROJECT-7 & 8 ENGG. STANDARD FOR ESCUTCHEON PLATES AND HANDSWITCHES.				DRG. No. RAPP-7&8/60427/2001/ES
					REV No.0 SCALE-N.T.S SHEET 18 OF 20

TYPES OF HAND SWITCHES

SL. NO.	POLES	POS 1	POS 2	POS 3	POS 4	REMARKS	
110	1 - 2	X					
	3 - 4	X					
	5 - 6	X					
	7 - 8			X			
	9 - 10			X			
	11 - 12			X			
	13 - 14				X		
	15 - 16				X		
	17 - 18				X		
	19 - 20						X
	21 - 22						X
	23 - 24						X

SL. NO.	POLES	POS 1	POS 2	POS 3	POS 4	POS 5	POS 6	POS 7	POS 8	REMARKS
111	1-2	X								
	3-4	X								
	5-6	X								
	7-8		X							
	9-10		X							
	11-12		X							
	13-14			X						
	15-16			X						
	17-18			X						
	19-20				X					
	21-22				X					
	23-24				X					
	25-26					X				
	27-28					X				
	29-30					X				
	31-32						X			
	33-34						X			
	35-36						X			
	37-38							X		
	39-40							X		
41-42							X			
43-44								X		
45-46								X		
47-48								X		

A4

SL. NO.	POLES	POSITION # 1	POSITION # 2	POSITION # 3	POSITION # 4	REMARKS
112	1 - 2	X				KEY OPERATED SWITCH, KEY CAN BE REMOVED IN OFF POSITION ONLY.
	3 - 4		X			
	5 - 6			X		
	7 - 8				X	

3581/2012	<i>[Signature]</i> 6/19/2012	<i>[Signature]</i> 6/19/2012	<i>[Signature]</i> 6/19/2012	<i>[Signature]</i> 6/29/2012	 NUCLEAR POWER CORPORATION OF INDIA LTD. (A GOVERNMENT OF INDIA ENTERPRISE)
I.S. No.	DR'N.	DES'D	D.CHK'D	REV'D	
SIGNATURE & DATE					DRG. No. RAPP-7&8/60427/2001/ES
PROJECT	TITLE: RAJASTHAN ATOMIC POWER PROJECT-7 & 8				
RAPP-7&8	ENGG. STANDARD FOR ESCUTCHEON PLATES AND HANDSWITCHES.				SCALE-N.T.S

TYPES OF HAND SWITCHES

SL. NO.	POLES	POS 1	POS 2	POS 3	POS 4	POS 5	REMARKS
113	1-2	X					
	3-4	X					
	5-6	X					
	7-8	X					
	9-10			X			
	11-12			X			
	13-14			X			
	15-16			X			
	17-18				X		
	19-20				X		
	21-22				X		
	23-24				X		
	25-26					X	
	27-28					X	
	29-30					X	
	31-32					X	
33-34						X	
35-36						X	
37-38						X	
39-40						X	

SL. NO.	POLES	POS 1	POS 2	POS 3	POS 4	REMARKS
114	1 - 2	X	BLKD	BLKD		
	3 - 4	X	BLKD	BLKD		
	5 - 6	X	BLKD	BLKD		
	7 - 8	X	BLKD	BLKD		
	9 - 10	X	BLKD	BLKD		
	11 - 12	X	BLKD	BLKD		
	13 - 14			BLKD	BLKD	X
	15 - 16			BLKD	BLKD	X
	17 - 18			BLKD	BLKD	X
	19 - 20			BLKD	BLKD	X
	21 - 22			BLKD	BLKD	X
	23 - 24			BLKD	BLKD	X

A4

3581/2012	<i>[Signature]</i> 6/19/2012	<i>[Signature]</i> 6/19/2012	<i>[Signature]</i> 6/19/2012	<i>[Signature]</i> 6/29/2012	 NUCLEAR POWER CORPORATION OF INDIA LTD. (A GOVERNMENT OF INDIA ENTERPRISE)	
I.S. No.	DR'N.	DES'D	D.CHK'D	REV'D		APP'D
SIGNATURE & DATE						
PROJECT	TITLE: RAJASTHAN ATOMIC POWER PROJECT-7 & 8				DRG. No.	REV No.0
RAPP-7&8	ENGG. STANDARD FOR ESCUTCHEON PLATES AND HANDSWITCHES.				RAPP-7&8/60427/2001/ES	SCALE-N.T.S
						SHEET 20 OF 20