

TERMS AND CONDITIONS

1 Inviting Quotations:

Tender in Two part bids are invited from '**MICRO & SMALL ENTERPRISES (MSE's)**' only for supply of '**Wooden boxes & Planks**' as per BHEL drawings on '**SIX MONTH RATE CONTRACT**' basis.

It is mandatory to submit applicable certificates (i.e. District Industries Centers or Khadi and Village Industries Commission or Khadi and Village Industries Board or Coir Board or National Small Industries Corporation or Directorate of Handicrafts and Handloom or any other body specified by Ministry of Micro, Small and Medium Enterprises) along with techno commercial bid.

Sealed tenders in two parts; Part-I: Techno-commercial bid and Part-II: Price bid are hereby invited as per applicable specifications and Drawings provided by BHEL. The relevant documents are attached with the Enquiry.

The two bids should be submitted in **separate sealed inner envelopes** duly mentioning the detail as follows:

Bid	Description	Superscription on envelope	Min documents to be submitted
Part-I	Techno-Commercial bid in response to tender enquiry no. 1213-041 Dated 12.06.2012	PART-I "Techno-Commercial Bid" Tender Enquiry no. 1213-041 Dated 12.06.2012. Due date of opening: 09.07.2012 Sender:	<ol style="list-style-type: none"> 1. Registration details / filled registration format may be submitted 2. Acceptance of all terms and conditions and compliance to drawings. 3. Un-priced bid format showing taxes and duties structure (Prices not to be filled in bid).
Part-II	Price bid in response to tender enquiry no. 1213-041 Dated 12.06.2012	PART-II "Price Bid" Tender Enquiry no. 1213-041 Dated 12.06.2012. Due date of opening: 09.07.2012 Sender:	Price bid duly filled with prices in words & figures .In case of discrepancy between prices in fig and words, prices in words are final. Boxes prices in Rs. per box only.
PLEASE SEE AND FOLLOW THE CHECKLIST PROVIDED AT THE END			

All the sealed envelopes should be put in an outer envelope clearly mentioning Tender Enquiry No., item description as "Wooden boxes and planks" and due date of opening as 09.07.2012 time 1530 Hrs. on it.

Bidders should primarily be engaged in wooden boxes/crates manufacturing/wooden items. BHEL may carry out evaluation of bidder's capability. BHEL reserves the right to accept/reject any offer based on evaluation of bidder's capability. BHEL may decide to visit the bidder(s) works. Any fact found deviating from bids during evaluation shall make the bidder liable to be dis-qualified. **Bidders, who are not currently on registered list of BHEL IVP Goindwal Sahib, may submit duly filled format for "Vendor Registration form" along with MSE certificates. This duly filled form can be submitted separately/immediately without waiting for the tender**



TERMS AND CONDITIONS FOR
(Tender Enquiry No. 1213-041 Dated 12.06.2012 Due date of opening 09.07.2012)
Item: Wooden Boxes and Planks

opening. If submitted separately, in the tender documents pl. mention that form has already been submitted with reference no. This will enable BHEL to evaluate the form and help in finalising the tender at the earliest. The form can be downloaded from our website www.bhel.com or can be requested at gss@ivp.bhel.in or vishal@ivp.bhel.in or osho@bhelivp.in

BHEL reserves the right to reject offer of any bidder based on past performances in rate contracts for supply of wooden boxes and planks with our unit.

Part-I: Techno-Commercial bid should contain

- a) The details/data/ information/ supporting certificates for MSE as per requirement.
- b) Acceptance of Techno-Commercial terms and conditions should be attached next. This can be attached either by signing each page of terms and conditions & Drawings or a confirmation statement. Any deviation proposed by bidder shall be considered by BHEL at its own discretion; and if finally considered, shall carry loading factor at the discretion of BHEL.
- c) Un priced price bid, filling all other details except **prices**.
- d) Monthly CFT commitment to be mentioned in bid

Sealed quotations shall reach by 1500 Hrs on due date. Part-I shall be opened on due date at 1530 Hrs. Based on evaluation of pre-qualification and/or techno-commercial offers, Price bids of bidders who qualify from pre-bid qualification and techno-commercial evaluation shall be opened. Date of opening of Price bid shall be informed to all successful bidders.

Part II: Price Bids should contain:

Price quotation format shall be as attached.

Present rate of VAT/CST & Excise duty + any cess on ED shall be mentioned in the table as %. All duties shall be paid extra. However, the comparison among bidders shall be done on the basis of quoted rates converted to "Total landed cost to BHEL". Duties shall be payable extra against ED Gate Pass valid for CENVAT benefit.

Price quoted shall be firm and not subject to any escalation during the PO execution.

Price should be quoted on **FOR Destination Goindwal Sahib** basis. If not mentioned, it shall be concluded that the offer is on FOR Destination Goindwal Sahib basis.

IF THE OFFER IS NOT ACCOMPANIED WITH ACCEPTANCE OF TERMS AND CONDITIONS, IT SHALL BE CONCLUDED THAT ALL THE TERMS AND CONDITIONS ARE ACCEPTABLE AND NO CLAIM WHATSOEVER SHALL BE ENTERTAINED LATER ON.

2 **Validity of offers:**

Offers shall be valid for **120 days** from due date of opening. In case of extension of due date of opening, the offers validity shall be extended accordingly. ***The rate contract period will be for six***

months- tentatively from Oct 2012 to Mar 2013 and may vary one month range from this period.
Purchase orders will be released in this rate contract period only.

3 **Terms of payment:**

C4.1 Due payment against supplies received shall be made within 30-45 days of receipt subject to acceptance of material by BHEL and receipt of following dispatch documents. In case of any deviation from standard payment term mentioned BHEL at it's discretion may load on the item price at prime lending rate of SBI + 2% for the period of relaxation sought by bidder.

C4.1.1 Commercial invoice (in duplicate).

C4.1.2 Original VAT invoice valid for claiming input tax credit.

C4.1.3 Compliance Certificate & Inspection clearance certificate released at the time of Pre-Despatch inspection at vendor's works, if any.

C4.2 Above documents should include your Registration numbers such as ECC no, PAN no, CST no, TIN/ VAT nos. etc.

C4.3 BHEL will not be responsible for delays in release of payment on account of discrepancies in documentation, so vendor has to ensure compliance to documentation requirement

C4.5 BHEL releases payment through EFT mode. Vendor can provide the necessary details by obtaining format before release of payment while supplying the material

4 **Delivery schedule:**

Sequence of delivery shall be indicated by BHEL while placing the orders/through other communications. Vendor shall be required to complete the order **as per Purchase orders placed time to time within rate contract period as per monthly CFT commitment.**

5 **Access to Manufacturing Premises:**

For evaluation & during the currency of execution of PO, authorized representatives of BHEL shall be allowed free access to the manufacturing facilities for the purpose of inspection or monitoring the progress of purchase orders. This access will also be extended to representatives of BHEL's customers accompanying the authorized representative/s of BHEL, if our contractual requirements with our customers call for the same.

6 **Quantity:**

Quantity mentioned in the annexure is indicative and can vary by 50%- item wise or full tender wise. BHEL may decide to increase or decrease the quantity by 50% or change the mix of items according to our requirement. Quantity variation from vendors' side is not allowed in negative side. Only positive side variation to the extent of 25% of individual item in PO can be considered

at the discretion of BHEL. A request has to be made for the same for consideration by BHEL before despatch of any such excess material.

7 **Loading:**

BHEL reserves the right to cancel/ refloat the tender, if the prices are abnormally higher than estimates. Further, BHEL reserve the right to negotiate with L1 vendor and split the tender among bidders to meet its requirement by giving counter offers. If registered vendor is L1, it shall be given minimum of 60% of quantity indicated or its CFT capacity. BHEL reserves the right to accept/reject any bid for any reason of past performance of bidder.

BHEL reserves the right to give counter-offer to any number of vendors. Loading beyond L1's capacity (or BHEL discretion beyond 60%, as the case may be) shall be done on L2, if it accepts counter-offers. If L2 is not able to take balance load (criteria: minimum of 30% and its capacity), L3 shall be contacted. If L2 does not accepts counter-offer, L3 shall be automatically contacted for next loading reserved for L2 and so on. BHEL reserves the right to continue placing orders on any higher bidder who has accepted RC for meeting its requirement, if L1 bidder is new vendor and is taking time for executing development order/any other issue.

BHEL reserves the discretion of deciding loading in any proportion depending upon execution of orders by suppliers and our requirement. Maximum loading to L1 shall be ensured provided despatches are made as committed. BHEL reserves the right of not giving counter-offer to highest bidder.

4% of the tender quantity offered to the MSE's shall be reserved for MSE's owned by SC/STs. In event of failure of such Micro and Small Enterprises to participate in tender process or meet tender requirements and L1 price, 4 per cent quantity for Micro and Small Enterprises owned by SC/ST entrepreneurs shall be met from other Micro and Small Enterprises.

All above mentioned preferences shall be given to MSEs and SC/STs only on the submission of documentary evidence.

8 **Risk Purchase**

BHEL shall be entitled to terminate the contract with any vendor and to purchase elsewhere at the risk and cost of the vendor, either the whole or part thereof which the supplier has failed to deliver within the time stipulated as aforesaid. Vendor shall be liable for the losses, which BHEL may sustain by way of such risk purchase in addition to aforesaid penalty for delayed delivery. Purchases made from any other vendor at its quoted rates shall be made and the difference of rates of defaulter vendor and new vendor shall be deducted from running bills of the vendor who has failed to deliver.

9 **Liquidated Damages**

'Time is the essence of the contract'. As such, delivery of goods specified in the Purchase Orders shall be made within the time limit prescribed therein. Liquidated damages clause will be applicable for delayed supplies @ 0.5% per week or part there of subject to a maximum of 5%. Once the delivery period mentioned has expired, and BHEL may or may not take the delivery of item.



BHEL GOINDWAL

TERMS AND CONDITIONS FOR
(Tender Enquiry No. 1213-041 Dated 12.06.2012 Due date of opening 09.07.2012)
Item: Wooden Boxes and Planks

10 **Force Majeure:**

If at any time during the continuance of the contract, the performance in which or in any part by either party of any obligations under the contract are prevented or delayed by reason of any war, hostilities, acts of public enemy, civil commotion, sabotage, fires, explosions, epidemics, quarantine restrictions, or acts of God (hereinafter referred to "an events") then provided the notice of happening of any such event is given by either party to the other within 21 days of the occurrence thereof, neither party shall by reason of such event be entitled to terminate the contract nor shall either party have any claim for damages against the other in respect of such non-performance and delay in performance and delivery under the contract shall be resumed as soon as practicable after such event has come to an end or ceased to exist. If the performance in whole or part of any obligation under the contract is prevented or delayed by reason of any such event, claims of extension of time shall be granted for periods considered reasonable by BHEL subject to prior notification by the vendor to BHEL of the particulars of the event and supply to BHEL, if required, of any supporting evidence. Any waiver of time in respect of partial installment shall not be deemed a waiver of time in respect of remaining deliveries.

11 **Arbitration:**

In the event of any dispute and/or difference arising between the Vendor and BHEL as to interpretation and/or execution of the contract and/or the respective rights and liabilities of the parties, such disputes and/or differences shall be referred to the sole arbitrator nominated by BHEL. The provisions of the Indian Arbitration Act and the rules thereunder shall apply to such arbitration. The award passed by the arbitrator shall be final and conclusively binding on all the parties.

12 **Jurisdiction:**

The court of the place from where the purchase order is issued shall alone have jurisdiction to decide any dispute arising out of or in connection with the purchase order.\

13 **Banned Firms**

The offers of the bidders who are on the banned list as also the offer of the bidders, who engage the services of the banned firms, shall be rejected. The list of banned firms is available on BHEL website www.bhel.com.

14 **MSME & MSE Certification:**

If the bidder is registered as any of Micro/Small/Medium enterprise as defined in Micro Small and Medium Enterprises Development Act, 2006; a copy of registration certificate to be attached. If the bidder is registered as any of Micro/Small/Medium enterprise as defined in Micro Small and Medium Enterprises Development Act, 2006; a copy of registration certificate to be attached. If the bidder is registered as any of Micro/Small/Medium enterprise as defined in Micro Small and Medium Enterprises Development Act, 2006; a copy of registration certificate to be attached. MSE's shall be given preferences as described in "Public Procurement Policy for Micro and Small Enterprises (MSEs) Order, 2012" subject to the submission of proper documentary evidence (i.e. District Industries Centers or Khadi and Village Industries Commission or Khadi and Village Industries Board or Coir Board or National Small Industries Corporation or Directorate of Handicrafts and Handloom or any other body specified by Ministry

of Micro, Small and Medium Enterprises) with quotation. "Public Procurement Policy for Micro and Small Enterprises (MSEs) Order, 2012" document can be downloaded from link <http://dcmsme.gov.in/FinalPressorder.pdf> and can also be collected from the office of Manager/MM IVP Goindwal.

15 **General:**

- a) BHEL will not be bound by any power of attorney granted by the vendors or by changes in the composition of the firm made subsequent to the execution of the contract. They may, however, recognize such power of attorney and changes after obtaining proper legal advice, the cost of which will be chargeable to the vendor concerned.
- b) BHEL reserves the right to accept or reject any part or whole of the tender by assigning a valid reason thereof. BHEL reserves the right to cancel the tender without assigning any reason thereof and without any obligation before any commitment.
- c) Please submit acceptance of all techno-commercial terms along with quotation. If nothing is mentioned for any term, it shall be concluded that the same is acceptable.
- d) Performance of suppliers shall be monitored periodically by user department of BHEL.

16 **LOI (Letter of Intent)**

BHEL may issue LOI prior to the PO for any reason whatsoever. The LOI in such cases is to be treated as PO for all practical purposes and all the Terms & Conditions of the tender shall be applicable from the date of issue of LOI.

17 **PREFERENCES FOR MSE'S:**

Preferences as mentioned in "Public Procurement Policy for Micro and Small Enterprises (MSEs) Order, 2012" shall be given to Micro and Small enterprises.

Main points which are mentioned in the above order are as follows:

- 20% Procurement of the tender value shall be made from MSE (Micro, Small Enterprises) firms.
- 4% from the above mentioned 20% procurement quantity shall be procured from MSE's owned by SC /ST's. Failure to participate by any MSE owned by SC/ST's this 4% quantity shall be procured from other MSEs.
- EMD shall be exempted for MSE's. All these benefits are subject to production of all statutory documents
- In tender, participating Micro and Small Enterprises quoting price within price band of L1+15 per cent shall also be allowed to supply a portion of requirement by bringing down their price to L1 price in a situation where L1 price is from someone other than a Micro and Small Enterprise and such Micro and Small Enterprise shall be allowed to supply up to 20 per cent of total tendered value. In case of more than one such Micro and Small Enterprise, the supply shall be shared proportionately (to tendered quantity).

All these preferences are applicable subject to the submission of applicable certificates (i.e. District Industries Centers or Khadi and Village Industries Commission or Khadi and Village Industries Board or Coir Board or National Small Industries Corporation or Directorate of Handicrafts and Handloom or any other body specified by Ministry of Micro, Small and Medium Enterprises).



TERMS AND CONDITIONS FOR
(Tender Enquiry No. 1213-041 Dated 12.06.2012 Due date of opening 09.07.2012)
Item: **Wooden Boxes and Planks**

TECHNICAL TERMS:

18 **Scope of Supply:**

Material shall be supplied as per the applicable latest Technical Delivery Conditions (TDC), drawing and other special requirement as given in the Purchase Order. If requested, BHEL may allow assembly of boxes from shooK /sides in its premises at its own discretion.

19 **Applicable Technical Delivery Conditions:**

All boxes are to be supplied as per enclosed drawings. The material used shall meet the TDC requirement/Standard requirements as mentioned in annexure.

20 **Inspection:**

BHEL may decide to carry out the inspection of packing boxes/parts prior to despatch. Pl. give your inspection call on readiness of material. Compliance Certificates are to be provided along with the supplies clearly detailing out the description of materials used and their compliance to the relevant standards.

21 **Replacement/Repair of Rejected boxes:**

If any box is found defective and is not acceptable, it shall be intimated through Rejection Memo or similar communication from BHEL and shall have to be repaired by supplier from BHEL at his own cost. BHEL reserves the discretion to levy storage charges for material not lifted within the reasonable period.

22 **Marking and certificates:**

Marking shall be as per drawing. Good stencil and ink/paint shall be used.

One side:	Opposite Side:
CONSIGNEE :	
OA NO./WO NO.:	Box Supplier : <i>Your Company Name</i>
CASE NO. :	
NO. OF VALVES:	Box Type:
WEIGHT :	
FROM :BHEL-GOINDWAL-TARN TARAN	



TERMS AND CONDITIONS FOR
(Tender Enquiry No. 1213-041 Dated 12.06.2012 Due date of opening 09.07.2012)
Item: **Wooden Boxes and Planks**

CHECKLIST AND SEQUENCE OF DOCUMENTS TO BE SUBMITTED IN TWO PARTS BIDS

S. No.	Document	Status [pl. check the following for ready ref]
1.	First envelope should contain (1) MSE certificates (2) Unprice bid	Sealed envelope marked as Part-I "Techno-Commercial Bids" Yes 1. MSE certificate 2. Acceptance of techno-commercial terms and compliance to drawings 4. Unpriced bid attached 5. Vendor registration form may be submitted
2.	Price Bid sealed in separate Second envelope superscribing tender enquiry detail, due date of opening, sender address	Sealed envelope marked as Part-II "Price Bid" Yes Envelop sealed
3.	All three sealed envelopes put in an outer envelope mentioning all details like Enquiry no., description, due date	Yes

**BHARAT HEAVY ELECTRICALS LTD
IVP, GOINDWAL SAHIB
UN PRICE BID ANNEXURE**

Annexure to Enquiry No. 1213-041 Dt 12.06.2012, due date of opening 09.07.2012

Material : Wooden boxes and planks

S.No.	Matl Code	Desc	Drawing No	Qty (No.)	Quoted	Unit rates, Rs per box *	
						In Fig.	In Words
1	GWB67035001	WOODEN PACKING BOX NO : 2	4-V-4000-07183	150	Yes/No		"Not to be filled by supplier-Please see Price Bid"
2	GWB67035002	WOODEN PACKING BOX NO : 2A	4-V-4000-07183	300	Yes/No		"Not to be filled by supplier-Please see Price Bid"
3	GWB67035003	WOODEN PACKING BOX NO : 3A	2-SH-BW-022/5	400	Yes/No		"Not to be filled by supplier-Please see Price Bid"
4	GWB67035004	WOODEN PACKING BOX NO : 4	2-SH-BW-022/5	400	Yes/No		"Not to be filled by supplier-Please see Price Bid"
5	GWB67035005	WOODEN PACKING BOX NO : 5	2-SH-BW-022/5	500	Yes/No		"Not to be filled by supplier-Please see Price Bid"
6	GWB67035006	WOODEN PACKING BOX NO : 6	2-SH-BW-022/5	600	Yes/No		"Not to be filled by supplier-Please see Price Bid"
7	GWB67035007	WOODEN PACKING BOX NO : 7	2-SH-BW-022/5	400	Yes/No		"Not to be filled by supplier-Please see Price Bid"
8	GWB67035008	WOODEN PACKING BOX NO : 9A	2-SH-BW-022/5	600	Yes/No		"Not to be filled by supplier-Please see Price Bid"
9	GWB67035009	WOODEN PACKING BOX NO : 10A	2-SH-BW-022/5	900	Yes/No		"Not to be filled by supplier-Please see Price Bid"
10	GWB67035010	WOODEN PACKING BOX NO : 13A	2-SH-BW-022/5	500	Yes/No		"Not to be filled by supplier-Please see Price Bid"
11	GWB67035011	WOODEN PACKING BOX NO : 14A	2-SH-BW-022/5	600	Yes/No		"Not to be filled by supplier-Please see Price Bid"
12	GWB67035012	WOODEN PACKING BOX NO : 14B	2-SH-BW-022/5	750	Yes/No		"Not to be filled by supplier-Please see Price Bid"
13	GWB67035013	WOODEN PACKING BOX NO : 15	2-SH-BW-022/5	250	Yes/No		"Not to be filled by supplier-Please see Price Bid"
14	GWB67035014	WOODEN PACKING BOX NO : 16	2-SH-BW-022/5	150	Yes/No		"Not to be filled by supplier-Please see Price Bid"
15	GWB67035101	WOODEN PLANKS SIZE 1"x 4" x 28"		5000	Yes/No		"Not to be filled by supplier-Please see Price Bid"
16	GWB67035102	WOODEN PLANKS SIZE 1"x4"x 32"		5000	Yes/No		"Not to be filled by supplier-Please see Price Bid"
17	GWB67035103	WOODEN PLANKS SIZE 2"x 4" x 28"		40000	Yes/No		"Not to be filled by supplier-Please see Price Bid"
18	GWB67035104	WOODEN PLANKS SIZE 2"x 4" x 32"		40000	Yes/No		"Not to be filled by supplier-Please see Price Bid"
19	GWB67035105	WOODEN PLANKS SIZE 2"x 4" x 36"		6000	Yes/No		"Not to be filled by supplier-Please see Price Bid"
20	GWB67035106	WOODEN PLANKS SIZE 2"x 4" x 38"		7500	Yes/No		"Not to be filled by supplier-Please see Price Bid"
21	GWB67035107	WOODEN PLANKS SIZE 2"x 4" x 50"		6000	Yes/No		"Not to be filled by supplier-Please see Price Bid"
22	GWB67035108	WOODEN PLANKS SIZE 1"x 4" x 36"		3000	Yes/No		"Not to be filled by supplier-Please see Price Bid"

Excise Duty rate (mention in % if applicable, mention as NIL if not applicable)

Pl. clearly mention

Cess on ED rate (mention in % if applicable)

Pl. clearly mention

CST (%) / VAT (%)

Pl. clearly mention

Validity of offers (As per BHEL terms 120 days validity is required)

Pl. clearly mention

Delivery terms (FOR Goindwal Sahib)

Pl. clearly mention

Payment terms (As per BHEL-within 30 to 45 days from receipt and acceptance of material)

Pl. clearly mention

Monthly CFT Commitment

Pl. clearly mention

MICRO OR SMALL ENTERPRISE (MSE) certificate enclosed

YES OR NO

We accept all terms and conditions of the Tender Enquiry No. 1213-041 Dt 12.06.2012

*Prices shall be firm without any escalation for SIX MONTH RATE CONTRACT period

Authorised signatory with seal



**BHARAT HEAVY ELECTRICALS LTD
IVP, GOINDWAL SAHIB
PRICE BID ANNEXURE**

Annexure to Enquiry No. 1213-041 Dt 12.06.2012, due date of opening 09.07.2012

Material : Wooden boxes and planks

S.No.	Matl Code	Desc	Drawing No	Qty (No.)	Unit rates, Rs per box *	
					In Fig.	In Words
1	GWB67035001	WOODEN PACKING BOX NO : 2	4-V-4000-07183	150		
2	GWB67035002	WOODEN PACKING BOX NO : 2A	4-V-4000-07183	300	"To be filled by supplier"	"To be filled by supplier"
3	GWB67035003	WOODEN PACKING BOX NO : 3A	2-SH-BW-022/5	400	"To be filled by supplier"	"To be filled by supplier"
4	GWB67035004	WOODEN PACKING BOX NO : 4	2-SH-BW-022/5	400	"To be filled by supplier"	"To be filled by supplier"
5	GWB67035005	WOODEN PACKING BOX NO : 5	2-SH-BW-022/5	500	"To be filled by supplier"	"To be filled by supplier"
6	GWB67035006	WOODEN PACKING BOX NO : 6	2-SH-BW-022/5	600	"To be filled by supplier"	"To be filled by supplier"
7	GWB67035007	WOODEN PACKING BOX NO : 7	2-SH-BW-022/5	400	"To be filled by supplier"	"To be filled by supplier"
8	GWB67035008	WOODEN PACKING BOX NO : 9A	2-SH-BW-022/5	600	"To be filled by supplier"	"To be filled by supplier"
9	GWB67035009	WOODEN PACKING BOX NO : 10A	2-SH-BW-022/5	900	"To be filled by supplier"	"To be filled by supplier"
10	GWB67035010	WOODEN PACKING BOX NO : 13A	2-SH-BW-022/5	500	"To be filled by supplier"	"To be filled by supplier"
11	GWB67035011	WOODEN PACKING BOX NO : 14A	2-SH-BW-022/5	600	"To be filled by supplier"	"To be filled by supplier"
12	GWB67035012	WOODEN PACKING BOX NO : 14B	2-SH-BW-022/5	750	"To be filled by supplier"	"To be filled by supplier"
13	GWB67035013	WOODEN PACKING BOX NO : 15	2-SH-BW-022/5	250	"To be filled by supplier"	"To be filled by supplier"
14	GWB67035014	WOODEN PACKING BOX NO : 16	2-SH-BW-022/5	150	"To be filled by supplier"	"To be filled by supplier"
15	GWB67035101	WOODEN PLANKS SIZE 1"x 4" x 28"		5000	"To be filled by supplier"	"To be filled by supplier"
16	GWB67035102	WOODEN PLANKS SIZE 1"x4"x 32"		5000	"To be filled by supplier"	"To be filled by supplier"
17	GWB67035103	WOODEN PLANKS SIZE 2"x 4" x 28"		40000	"To be filled by supplier"	"To be filled by supplier"
18	GWB67035104	WOODEN PLANKS SIZE 2"x 4" x 32"		40000	"To be filled by supplier"	"To be filled by supplier"
19	GWB67035105	WOODEN PLANKS SIZE 2"x 4" x 36"		6000	"To be filled by supplier"	"To be filled by supplier"
20	GWB67035106	WOODEN PLANKS SIZE 2"x 4" x 38"		7500	"To be filled by supplier"	"To be filled by supplier"
21	GWB67035107	WOODEN PLANKS SIZE 2"x 4" x 50"		6000	"To be filled by supplier"	"To be filled by supplier"
22	GWB67035108	WOODEN PLANKS SIZE 1"x 4" x 36"		3000	"To be filled by supplier"	"To be filled by supplier"
Excise Duty rate (mention in % if applicable, mention as NIL if not applicable)						<i>Pl. clearly mention</i>
Cess on ED rate (mention in % if applicable)						<i>Pl. clearly mention</i>
CST (%) / VAT (%)						<i>Pl. clearly mention</i>
Validity of offers (As per BHEL terms 120 days validity is required)						<i>Pl. clearly mention</i>
Delivery terms (FOR Goindwal Sahib)						<i>Pl. clearly mention</i>
Payment terms (As per BHEL-within 30 to 45 days from receipt and acceptance of material)						<i>Pl. clearly mention</i>
Monthly CFT Commitment						<i>Pl. clearly mention</i>
MICRO OR SMALL ENTERPRISE (MSE) certificate enclosed						YES OR NO
We accept all terms and conditions of the Tender Enquiry No. 1213-041 Dt 12.06.2012						

***Prices shall be firm without any escalation for SIX MONTH RATE CONTRACT period**

Authorised signatory with seal



TYPE	DIMENSIONS			QTY
	A	B	C	
16	2134	915	1220	
16A	2743	1220	1070	
16B	2743	1220	1525	

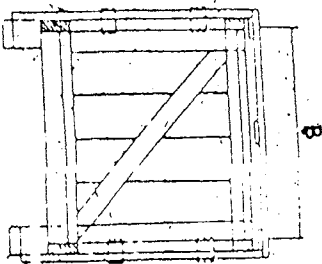
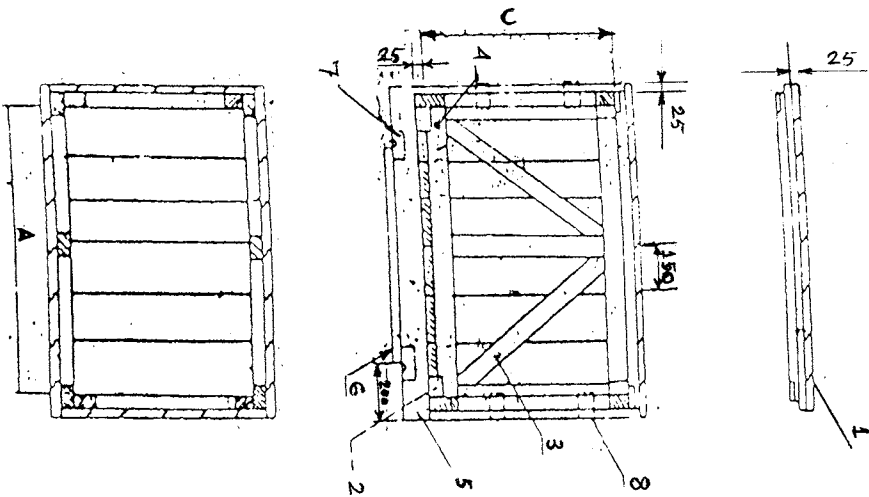

- NOTE**
1. HARD WOOD PLANKS THICKNESS 45 PER TDC.
 2. END TRAVERSERS BAR 100X50
 3. DIAGONAL BRACE 75X25
 4. HARD WOOD BATTE NS 75X25
 5. RUNNER 100X100 MM.
 6. RESTING BEAM 100X50 MM
 7. SLING PLATE [M.S. SHEET]
 8. SIDE PLATE [M.S. SHEET]

- NOTES FOR PACKING**
1. THE INSIDE OF ALL SIDES EXCEPT BOTTOM SHALL BE FULLY COVERED, BY POLYETHYLENE SHEET SO AS TO AVOID ENTRY OF RAIN WATER.
 2. SECURE THE ASSEMBLIES WITH ENOUGH SIDE SUPPORTS TO AVOID MOVEMENT OF ASSEMBLIES DURING TRANSIT.

TYPE	DIMENSIONS			QTY
	A	B	C	
1	570	570	570	
2	710	610	800	
3	830	530	570	
4	1000	770	570	
7	1100	570	570	
9	1250	570	1100	
10	1300	770	1050	
11	1700	440	700	
12	1850	1050	1150	
15	2000	800	800	
54	800	200	900	
9A	1250	570	710	
9B	1250	570	1050	
9C	1250	570	650	
9A	1300	770	710	
9B	1300	770	710	
9C	1300	770	1050	
16A	2743	1220	1070	
16B	2743	1220	1525	
16C	2743	1220	1770	

- REMARKS**
1. ALL THE PLANKS ARE TO BE THE GIVEN THICKNESS
 2. BOTTOM 2 RUNNERS

ALL DIMENSIONS ARE IN MM
A - LENGTH
B - BREADTH
C - HEIGHT



BHARAT HEAVY ELECTRICIANS LTD.
PACKING BOX

DRAWING NO: 2-SH-BW-022R06

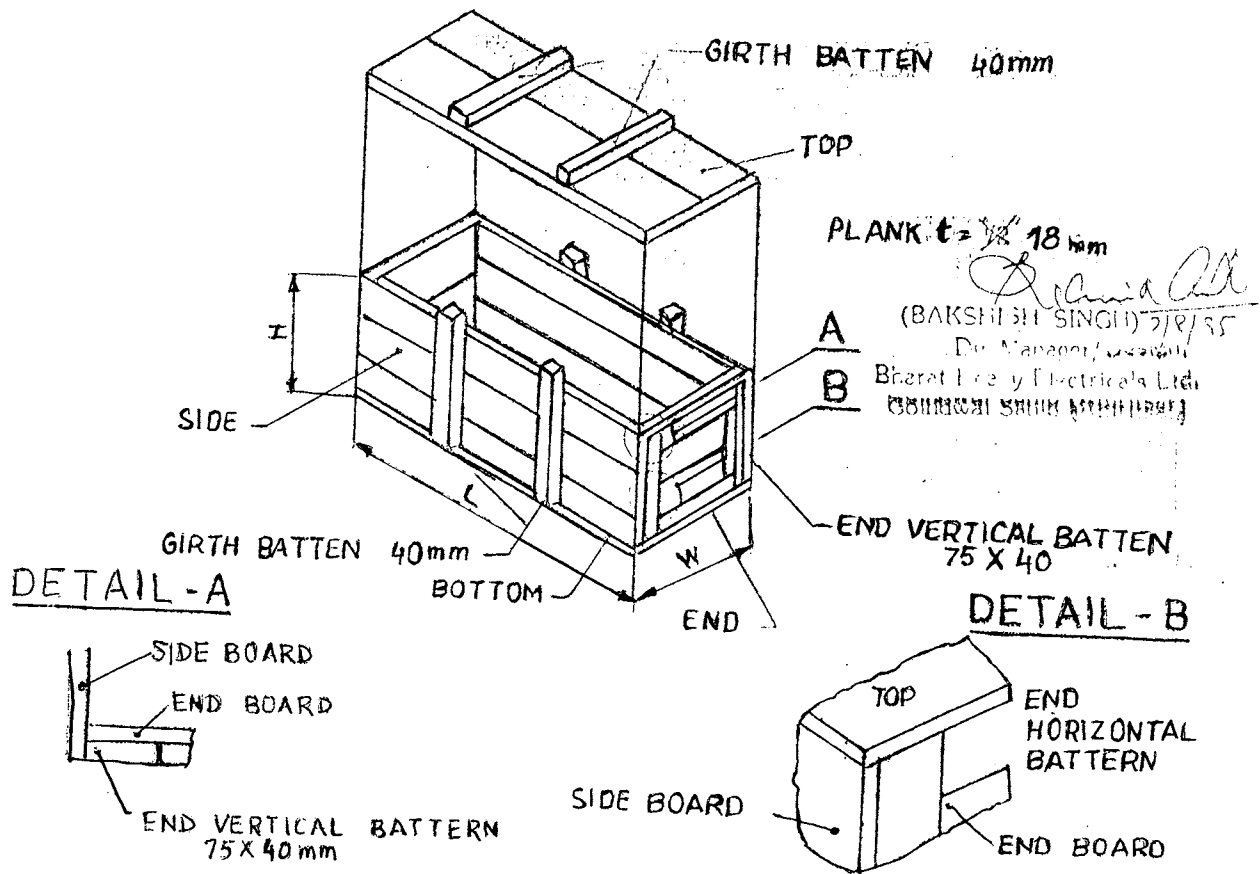

Box Type No 2A is added.
Bakshi S
 24/9/2002

TYPE NO			
	L	W	H
1A	320	250	260
1	320	250	430
2	430	370	430
2A	500	450	550

NOTES:-

1. ALL DIMENSIONS ARE IN mm.
2. L, W, H ARE INNER DIMENSIONS OF THE BOX.

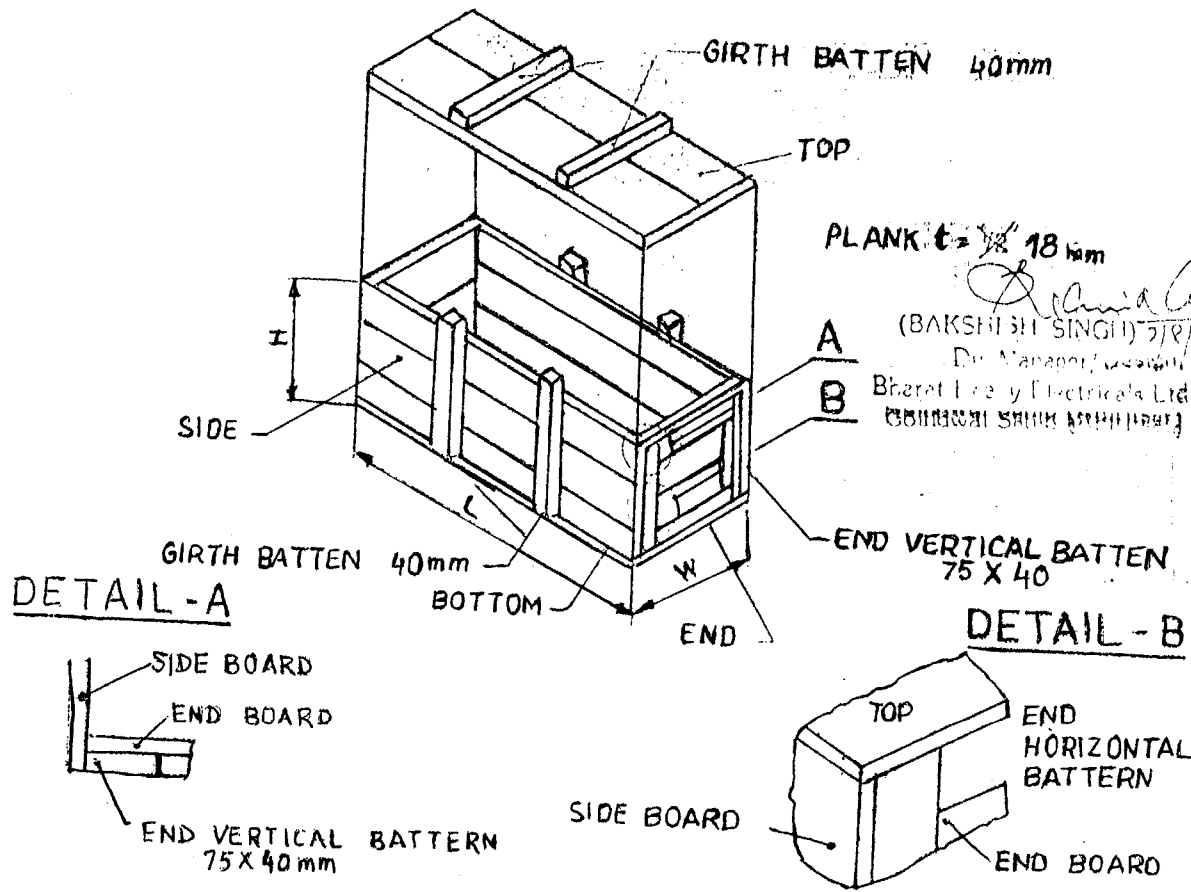

Box Type No 2A is added.
Bakshi Singh
 24/8/2002

TYPE NO				
	L	W	H	
1A	320	250	260	
1	320	250	430	
2	430	370	430	
2A	500	450	550	

NOTES:-

1. ALL DIMENSIONS ARE IN mm.
2. L, W, H ARE INNER DIMENSIONS OF THE BOX.

TYPE	DIMENSIONS			QTY
	A	B	C	
16	2134	915	1220	
16A	2743	1220	1070	
16B	2743	1220	1525	

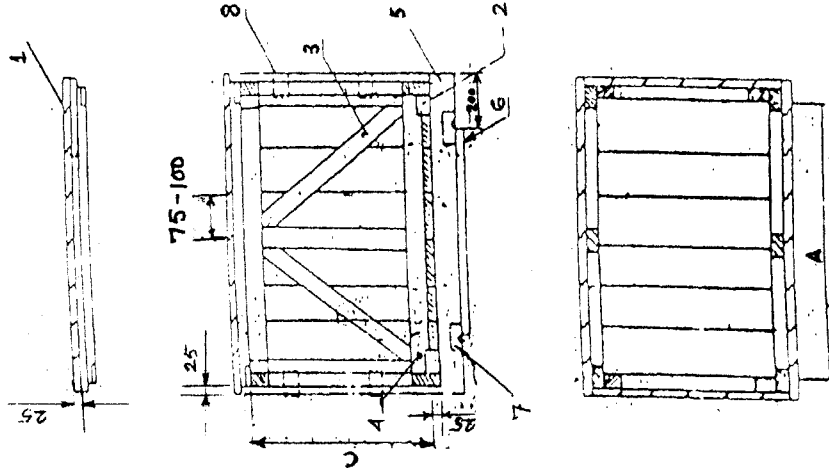

ALL DIMENSIONS ARE IN MM
 A - LENGTH
 B - BREADTH
 C - HEIGHT



TYPE	DIMENSIONS			QTY	REMARKS
	A	B	C		
1	678	678	678		1. ALL THE PLANKS ARE TO BE THE GIVEN THICKNESS 2. BOTTOM 2 RUNNERS
2	718	678	800		
3	818	678	678		
4	1000	778	678		
5	1188	678	878		
6	1260	578	1100		
7	1350	778	1050		
8	1700	440	700		
9	1850	1050	1150		
10	2000	800	800		
11	800	400	900		
12	678	500	500		
13	2350	578	700		
14	2750	700	1050		
15	1300	700	650		
16	1100	650	700		
16A	1850	700	700		
16B	2350	700	1170		

NOTES FOR PACKING
 1. THE INSIDE OF ALL SIDES EXCEPT BOTTOM SHALL BE FULLY COVERED, BY POLYETHYLENE SHEET SO AS TO AVOID ENTRY OF RAIN WATER.
 2. SECURE THE ASSEMBLIES WITH ENOUGH SIDE SUPPORTS TO AVOID MOVEMENT OF ASSEMBLIES DURING TRANSIT.
 3. DIMENSIONS CAN BE READ FROM T.O.C. FOR PACKING BOXES.

- NOTE
- HARD WOOD PLANKS THICKNESS AS PER T.D.C.
 - END TRAVERS BAR 100X50
 - DIAGONAL BRACE 75X25
 - HARD WOOD BATTEN 75X25
 - RUNNER 100X100 MM.
 - RESTING BEAM 100X50 MM
 - SLING PLATE [M.S. SHEET]
 - SIDE PLATE [M.S. SHEET]

BHARAT HEAVY ELECTRICALS LTD.
 PACKING BOX

Date of Issue: 04-03-2004
Date of Implementation: 04-03-2004
Rev: 03

Technical Delivery Conditions
For
Wooden Packing Boxes Made Of Non-Coniferous Timber

1. General:

This specification governs the quality of packing boxes of non-coniferous in the form of planks, battens as per the dimensions and drawing in different sizes as per annex.

2. Application:

Packing boxes/crates/battens shall be used at industrial valves plant for transportation of the valves and shall be duly provided with a black polythene lining, sufficiently strong to protect the valves from outside rain water or condensing moisture during and after transportation. The lining is not required for the base of the boxes. Corner plates made of mild steel measuring 150 x 100 x 1.0 mm. shall be nailed at two places for strengthening each vertical corner of the boxes and the base.

Compliance With National Standard:

Assistance has been derived from the following standards in the preparation of this specification.

-BHEL Corporate P.S. No. : AA 51402
-IS-1326-1976: Spn. For Non-Coniferous Timber
-IS-5966-1970: Spn. For Non-Coniferous Timber
in converted from for general purpose.

Dimensions & Tolerances:

Width, thickness and length of Planks/Battens Shall have the following tolerance:

Width	:	+ 3mm	from 75-100mm
		- 0	
Thickness	:	+ 5mm	from 100-200mm
		- 0	

Box Type No.	Planks	Diagonal Brace	Battens
2	18 +3 -0		+5 on the ordered -0 dimensions
3,3A, 4,4A, 5,5A, 6, 7,9A, 10A, 13A	20 +3 -0	25 +3 -0	+5 on the ordered -0 dimensions
9,9B, 10,11A, 13,14,14A, 14B, 15,16,16A, 16B	25 +3 -0	25 +3 -0	+5 on the ordered -0 dimensions

Length : As Per the Dimensions of the Boxes/ordered.

Moisture Content:

Normally no. Seasoning is required, however the moisture content should not exceed more than 40%.

Freedom from Defects:

- a) Brashness, splits across the grains, shakes, cups, twist, insect attack, centre heart in planks are the defects which are not acceptable.
- b) Following defects are acceptable when measured in accordance with IS-3364

Bow:

Shall be permissible upto a maximum of 2mm for 300mm

End Splits:

The largest end splits at each end shall be measured and the length added together. The added lengths of these shall not exceed 80mm per meter run of the piece.

Live / Dead Knots:

A maximum of 5 Knots/m length are permissible; however, the knots shall not be so grouped or located as to affect the strength of the piece. Knots above 35mm. diameter are not permissible. Major axis of the knot shall be taken as the diameter of this knot.

Surface Cracks:

Surface cracks with a depth of 10 % subject to a depth of 10mm are permissible. A continuous crack of any depth all along the length is not permissible. /

Certificate:

The supplier shall furnish a certificate with each lot/consignment in support of the species of the wood, moisture content, size of the nails used, and any special information which the tenderer feel is essential for the quality of the packing boxes and battens distance between two nails should be 50mm. Any hard wood species are acceptable.

Marking:

The boxes shall be marked/painted in order to identify the source of supply on two faces with additional stenciling on one face as:-

- CONSIGNEE:
- OA NO./WO. NO.:
- CASE NO. :
- NO. OF VALVES:
- WEIGHT:
- FROM: BHEL/GOINDWAL/TARN TARAN

BHEL/IVP/GOINDWAL

SIZES FOR THE PACKING BOXES

Box size No. Type	Dimensions (overall) (L. x W. x H.)
2	430x 370x 430
3A	670x 670x 500
4	710x 630x 600
5	850x 630x 600
6	1000x 770x 670
7	1100x 430x 670
9A	1250x 570x 710
10A	1300x 770x 850
13A	1300x 650x 710
14A	1850x 700x 710
14B	1850x 700x 1050
9B	1250x 570x 1050
16	2134x 915x 1220
16A	2743x 1220x 1070
16B	2743x 1220x 1525

N.B. 1. Supplier's Name and type of the box shall be stenciled on the boxes

**NON-CONIFEROUS TIMBER FOR GENERAL PACKING PURPOSES****1.0 GENERAL:**

This specification governs the quality requirements of Non-Coniferous Timber supplied in the form of planks, battens, beams and sleepers.

2.0 APPLICATION:

Used for general packing purposes.

3.0 COMPLIANCE WITH NATIONAL STANDARDS:

There is no National standard covering this material. However, assistance has been derived from the following National standards:

IS:1326-1992	Non-Coniferous Sawn Timber (Baulks & Scantling)
IS:5966-1993	Non-Coniferous Timber In Converted Form For General Purposes.
IS:6662-1993 Groups I & II	Timber Species Suitable For Wooden Packaging

4.0 TERMINOLOGY:

For the purpose of this specification, the definitions given in IS:707 (Glossary of terms applicable to timber and timber products) shall apply except for the beam which is defined as follows:

Beam is defined as converted timber whose cross-sectional dimensions exceed 50mm in both directions.

5.0 SPECIES:

Shall be as stated on the order.
Some standard species are:

<u>Trade Name</u>	<u>Botanical Name</u>
Rubber wood	Hevea brasiliensis
Salai	Boswellia serrata
Bahera	Terminalia bellirica
Jaman	Syzygium cumini

Revision: Cl. 6.2.3 of MOM of WG (T&PM)			Approved: INTERPLANT STANDARDIZATION COMMITTEE-WG(T&PM)		
Rev.No. 03	Amd.No.	Reaffirmed	Prepared BHOPAL	Issued CORP. R&D	Dt. of 1st Issue MAR '80
Dt. 1.10.95	Dt.	Year:			



<u>Trade Name</u>	<u>Botanical Name</u>
Lendi	Lagerstroemia parviflora
Mango	Mangifera indica
Machilus(Kalamavu)	Machilus macrantha
Irul	Xylis xylocarpa
Irulbaken	Hopes
Karumarudu	Terminalia tomentosa
Murtenga	Bursera serrata
Nangal	Mesua ferrea
Pillamarudu	Terminalia paniculata
Sai	Shorea robusta
Silver oak	Grevillea robusta
Tada(Dhaman)	Grewia tillifolia

Any other species of wood as per Groups I & II of IS:6662 may also be ordered.

6.0 DIMENSIONS AND TOLERANCES:

6.1 Sizes:

Width, thickness and length of timber shall be clearly stated on the order.

6.2 Tolerances:

6.2.1 Width : 50 to 250 mm Tolerance : ± 3 mm

6.2.2 Thickness : 20 to 250 mm Tolerance : $+3$ mm
-1 mm

6.2.3 Length:

Standard length : 1 to 12 metres in multiples of 0.5 metre.

Tolerance : $\pm 2\%$ or ± 25 mm whichever is less.

Note:

1.0 Measurements:

1.1 When nominal sizes are ordered, length, width and thickness shall be measured on the basis of accepted sizes. Plus tolerances shall not be added while computing the volume.



1.2 The measurements of length, width, thickness and computation of volume shall be as follows:

- a) The length shall be measured in metres in midline of a piece. The fractions of a metre shall be rounded off to the nearest lower 10 mm.
- b) The width shall be measured at the narrowest place in millimetres and shall be rounded off to the nearest lower one millimetre.
- c) The thickness shall be measured at the narrowest place in millimetres and shall be rounded off to the nearest lower one millimetre.
- d) The volume shall be computed in cubic metres correct to three places of decimal on the basis of accepted sizes.

2.0 Single sampling plan based on IS:2500 shall be followed.

7.0 MOISTURE CONTENT:

The timber shall have a moisture content as stated below within a depth of 15mm from the surface excluding a length of 300mm from each end at the time of inspection. The moisture content will be determined in accordance with Appendix-A of IS:287.

October to June : 30%
July to September (Rainy season) : 40%

8.0 FREE FROM DEFECTS:

Timber shall be free from the following defects:

Brashness, splits across the grain, shakes, spring, twist, insect attack, any kind of decay (rot), any sign of infection, open centre heart, centre heart on planks and any other defect.

Defects to the extent specified below are permissible. These defects shall be measured in accordance with IS:3364.

8.1 Row:

Shall be permissible upto a maximum of 2mm for 300mm length.

8.2 Wane:

- a) For sections upto and including 150 X 150 mm:

Shall be permissible upto $\frac{1}{5}$ of the width on the broad face subject to a maximum of 60mm and upto $\frac{1}{3}$ of the width on the narrow face subject a maximum of 40mm, provided that one broad face is completely free from this defect. The wane shall be measured at its deepest part.



b) For sections above 150 X 150 mm:

The cumulative lengths of waness on all the sides should not be more than one length of the piece.

8.3 End splits:

The longest end split at each end shall be measured and the lengths added together. The total length of these shall not exceed 60mm per metre run of the piece.

8.4 Live knots upto 35mm diameter:

A maximum of 5 knots/metre length are permissible. However, the knots shall not be so grouped or located as to affect the strength of the piece.

Live knots above 35mm diameter are not permissible.

8.5 Dead knots:

a) Below 10mm diameter:

A maximum of 3 knots/metre length are allowed provided that the knots are not so grouped or located as to affect the strength.

b) From 10mm to upto and including 25mm diameter:

A maximum of 2 knots allowed to the extent of 1 knot/metre length.

c) Above 25mm diameter:

Not allowed.

Note: (For clauses 8.4 & 8.5): Major axis of the knot should be taken as the diameter of the knot.

8.6 Surface cracks:

Surface cracks with a depth of 10% subject to a maximum of 10mm are permissible. A continuous crack of any depth all along the length is not permissible.

8.7 Sap wood:

Permissible upto a maximum of 12 percent of the cross sectional area.

9.0 END COATING:

Timber shall be coated with any of the following effective compositions upto a distance of 80mm from each end.

9.1 Thick coal tar or bituminous paint.



- 9.2 Resin and lamp black (10:1) melted, mixed and applied hot.
- 9.3 Hardened gloss oil.
- 9.4 Paraffin wax.
- 9.5 Molasses and lime (3:1).
- 9.6 Geru/Yellow clay.

10.0 INSPECTION AT SUPPLIER'S WORKS:

Whenever specified, tests and inspection are to be conducted in the presence of BHEL's representative. BHEL representative shall have free access at all times while work on the contract is being performed to all parts of the manufacturer works. The manufacture shall offer BHEL's representative all reasonable facilities, without charge, to satisfy the latter that the material is being furnished in accordance with this specification.

The manufacturer shall prepare and provide necessary test specimens for testing to be carried out at his premises. If facilities are not available at his works the manufacturer shall make necessary arrangements for carrying out the prescribed tests elsewhere. The manufacturer shall notify BHEL in advance about the readiness of the material for inspection and testing.

BHEL reserves the right to test the material at BHEL's Works and the final acceptance of the material shall be based on these test results.

11.0 TEST CERTIFICATES:

Three copies of test certificate shall be supplied unless otherwise stated on the order.

In addition, supplier shall ensure to enclose one copy of test certificate along with their dispatch documents to facilitate quick clearance of the material.

The test certificate shall have the following information:

AA 514 02 (Rev.No.03) : Non-Coniferous timber for general packing purposes

BHEL order No. :
Supplier's References :
Type & Specie :
Treatment, if any :
Results of Dimensional Inspection :
Moisture content :
Defects as per clause 8 :
Size :
Quantity supplied :

AA 514 02

REV.No. 03

PAGE 6 OF 6

CORPORATE PURCHASING SPECIFICATION



12.0 MARKING :

The timber shall be marked/painted with the following:

AA 514 02
BHEL order No. :
Supplier's Name :
Size & Quantity :

13.0 REJECTION AND REPLACEMENT :

If the material does not conform to the requirements of this specification or found defective during further processing, such material shall be rejected notwithstanding any previous certification of satisfactory testing and/or inspection. The supplier shall under take to replace the rejected consignment at his own cost and the rejected material shall be taken back by the supplier after fulfilling the commercial terms and conditions.

14.0 REFERRED STANDARDS:

The following is the list of the latest standards, as published by the respective issuing bodies, referred to in this specification.

- | | | | |
|------------|------------|------------|------------|
| 1) IS:287 | 2) IS:707 | 3) IS:1326 | 4) IS:2500 |
| 5) IS:3364 | 6) IS:5966 | 7) IS:6662 | |