

42

QUALITY ASSURANCE PLAN										
SHEET 1 OF 2										
Q.A.P. NO.-QAP DESCRIPTION OF JOB :- Drg.No: 2-61-104-02895/S R SPEC. NO.- BA75020 R03 AA19511 R09 DATED: G.H TOP COVER LEGENDS P- PERFORMED BY W- WITNESSED BY V - VERIFIED BY 1- SUPPLIER 2- BHEL/Nominated inspection agency										
Sl. No.	COMPONENT & OPERATION	CHARACTERISTIC	CLASSIFICATION	TYPE OF CHECK	QUANTUM OF CHECK	REFERENCE DOCUMENTS	ACCEPTANCE NORMS	FORMAT	AGENCY	REMARKS
									P   W   V	
1	1.0 Melt Analysis	Chemical	Major	Spectrometric	Each casting	AA 19511 R09	AA 19511 R09	Certificate	1	10 11 12
	2.1 Quality HT	NORMALIZING	Major	Time / Temp	Each Casting	AA 19511 R09	AA 19511 R09	Time/Temp graph	1	2
	2.2 Identification of casting and keel blocks	Test piece marking & casting identification	Major	2nos Integral keel block sample per Melt heat & vistial	100%	AA 19511 R09	AA 19511 R09	TPM CERTIFICATE	1	2
	2.3 Mechanical Testing	Tensile, Impact test	Critical	Mechanical	Per casting	AA 19511 R09	AA 19511 R09	Int. Record	1	
	2.4 Rough machining	Dim. Control	Major	Manual Measurement	Machined dim. With m/c allowance +1/-0 mm	Drg. and AA 19511 R09	Drg. and AA 19511 R09	Int. Record	1	
	2.5 Preliminary NDT	MPI UT	Major	NDT ( MP & UT)	100%	AA 0850133(MP)	AA 0850134 QL-2 ON ROUGH MACHINED SURFACE	Int. Record	1	
	2.6 Defect Excavation	Inspection of excavation and defect mapping	Critical	Visual MPI	Each Cavity	ASTM 609 (UT)	ASTM 609 QL-2UP TO 50MM & QL-3 ABOVE 50MM	Defectogram Int. Record	1	2
	2.7 Rectification welding	Qualification of WPS and Welder	Major	Performance Test	100%	WPS PQR	WPS PQR	Qual. Record	1	2
	2.8 Sterss Relieving	Time/Temp Chart	Major	Measuring Time / Temp.	100%	Each casting	BA75020 R03	Time/Temp Chart	1	2

*[Handwritten Signature]*  
 I.O. REGISTRAR  
 Quality Control Dept.  
 BHEL, RAIPUR

# QUALITY ASSURANCE PLAN

SHEET 2 OF 2

SI. No.		COMPONENT & OPERATION		CHARACTERISTIC	CLASSIFICATION	TYPE OF CHECK	QUANTUM OF CHECK	REFERENCE DOCUMENTS	ACCEPTANCE NORMS	FORMAT	AGENCY REMARKS		
											P	W	V
<p style="text-align: center;"><b>LEGENDS</b></p> <p>P - PERFORMED BY 1- SUPPLIER</p> <p>W - WITNESSED BY 2- BHEL/Nominated inspection agency</p> <p>V - VERIFIED BY</p>													
<p style="text-align: center;"><b>Q.A.P. NO.- QAP/01 REV.01</b>                      DATED 30/4/12                      DESCRIPTION OF JOB :- GH TOP COVER                      Drg.No: 2-61-104-02895/S R1                      SPEC. NO. - BA75020 R03                      AA19511 R09                      Sub-System :</p>													
1	2	3.0 Final Inspection 3.1 Final Internal 3.2 Final NDT	3	NDT/Visual/dim MPI UT	4	5	6	7	8	9	10	11	12
		3.3 Dim. Inspection thickness by UT 3.4 Mechanical Testing		Dim. Control Tensile, Impact Hardness, cleaning before marking and packing									
		4 packing and marking		All Doc. After testing									
		Summation of all qualities related documents for approval											
4.1													

**Remarks :-**  
 1.-Qualification of WPS will be witness by BHEL  
 2.- One keel Block will be tested with the casting at the time of dispatch  
 3. Mechanical testing & Hardness will be done per casting

  
 Prepared by

  
 Approved by

**I.D. KAMAL**  
 Engineer (LF-OC/OM)  
 OFFP, BHEL, HARIDWAR

**M. K. Aggarwal**  
 Senior Manager (QM)  
 OffP, BHEL, HARIDWAR



FIRST ANGLE PROJECTION ( ALL DIMENSIONS ARE IN M.M. )

SECTION A-A

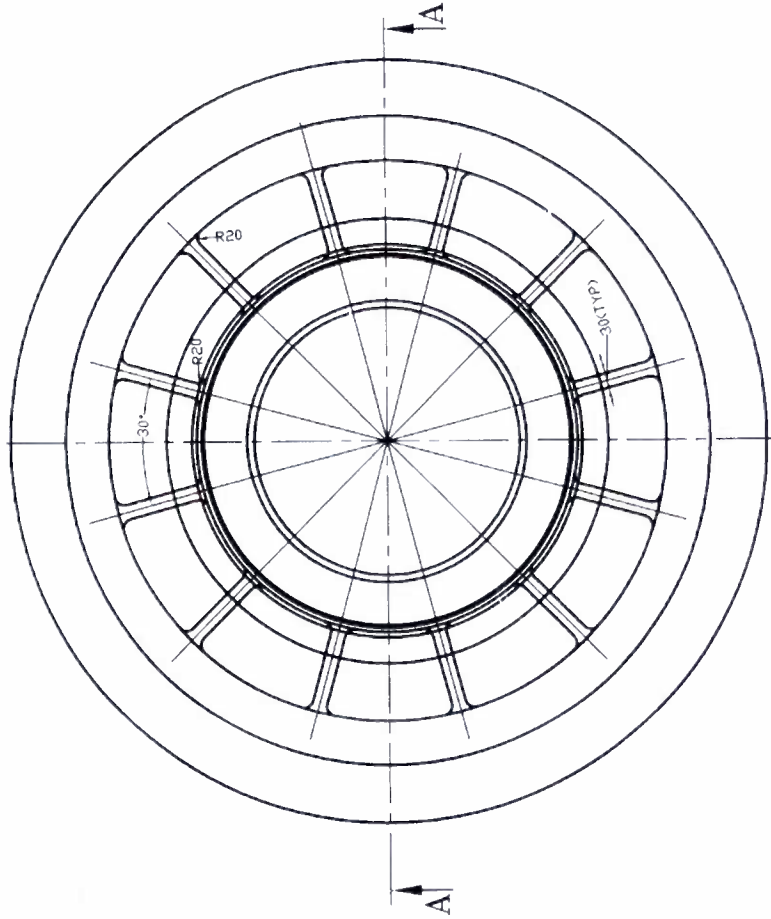
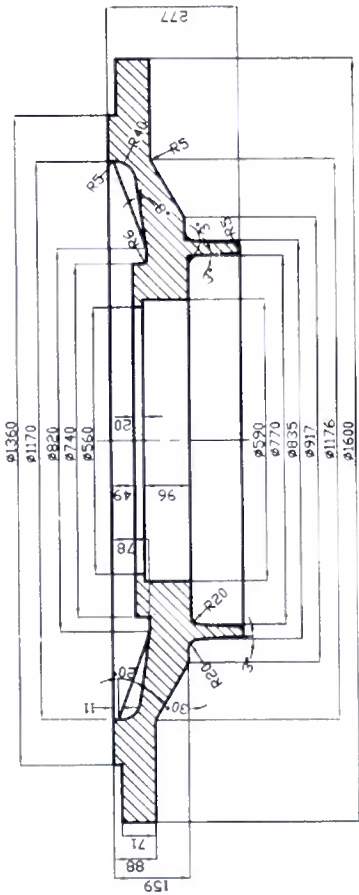

- NOTE:
1. CASTING TO BE ROUGH MACHINED TO DIMENSIONS INDICATED IN THE DRG. WITHIN +1/-0 MM TOLERANCES.
  2. NO MACHINING OF RIBS AND SURFACE BETWEEN THE RIBS.
  3. DEBURR ALL SHARP EDGES.
  4. CASTING SHOULD BE SUPPLIED IN LINE WITH TDC-BA75020 REV 0.3. HOWEVER NDT CRITERIA & ANNEXURE-D OF THE TDC SHALL NOT BE APPLICABLE. THE VENDOR IS TO DECIDE ITS OWN STRESS RELIEVING TEMPERATURE.
  5. FOLLOWING NDT TO BE CARRIED OUT:  
UT ON ROUGH MACHINED SURFACE ONLY; AS PER ASTM A609 QL2 FOR THICKNESS UPTO 50 MM AND QL3 FOR THICKNESS ABOVE 50 MM.  
MP ON ROUGH MACHINED SURFACES ONLY; AS PER AA0850133, ACCEPTANCE AS PER QL2 OF AA0850134
  6. THE MANUFACTURING PLAN AND QUALITY INSPECTION PLAN IS TO BE SUBMITTED BY VENDOR AS PER THE REQUIREMENT OF TDC BA75020.

		<b>BHARAT HEAVY ELECTRICALS, LTD.</b>	
CENTRAL FOUNDRY FORGE PLANT		RANIPUR HARDWAR	
DEPT. FDY. TECH.	SCALE N.T.S.	WEIGHT IN KG 1150	DATE
TITLE		DRN H.D./37.3/BBB/4	SIGN
GEAR HOUSING COVER & BEARING SUPPORT (TOP)		CHKD JERANNA 30	DATE
PROJECT AND CUSTOMER NAME		CHKD K. JANKA 83	DATE
TECHNOLOGY NO		APPD DAVE 83	DATE
DRAWING NO		2-61-104-02895/S	NO. OF SHEETS-3
SHEET NO.-1		BHEL	

REV	DATE	ALTERED	CHECKED
ZONE			

20

QUALITY ASSURANCE PLAN										SHEET 1 OF 2		
Q.A.P. NO.-QAP/ DESCRIPTION OF JOB :- Drg.No: 3-61-010-03439 /S R00 SPEC. NO.- BA75020 R03 AA19511 R09 Sub-System : JOURNAL HOUSING										DATED: LEGENDS P - PERFORMED BY W - WITNESSED BY V - VERIFIED BY		
Sl. No.	COMPONENT & OPERATION	CHARACTERISTIC	CLASSIFICATION	TYPE OF CHECK	QUANTUM OF CHECK	REFERENCE DOCUMENTS	ACCEPTANCE NORMS	FORMAT	AGENCY	REMARKS		
									P W V			
1	1.0 Melt Analysis	Chemical	Major	Spectrometric	Each casting	AA 19511 R09	AA 19511 R09	Certificate	1	11		
2.1	Quality HT	NORMALIZING	Major	Time / Temp	Each Casting	AA 19511 R09	AA 19511 R09	Time/Temp graph	1	2		
2.2	Identification of casting and keel blocks	Test piece marking & casting identification	Major	Znos Integral keel block sample per Melt heat & visual	100%	AA 19511 R09	AA 19511 R09	TPM CERTIFICATE	1	2		
2.3	Mechanical Testing	Tensile, Impact test	Critical	Mechanical	Per casting	AA 19511 R09	AA 19511 R09	Int. Record	1			
2.4	Rough machining	Dim. Control	Major	Manual Measurement	Machined dim. With m/c allowance +2/-0 mm at OD, -2/+0 mm at ID	Drg. and AA 19511 R09	Drg. and AA 19511 R09	Int. Record	1			
2.5	Preliminary	MPI	Major	NDT ( MP & UT)	100%	AA 0850133(MP)	AA 0850134 QL-2 ON ROUGH MACHINED SURFACE	Int. Record	1			
2.6	Defect Excavation	Inspection of excavation and defect mapping	Critical	Visual MPI	Each Cavity	ASTM 609 (UT)	ASTM 609 QL-2UP TO 50MM & QL-3 ABOVE 50MM	Defectogram Int. Record	1	2		
2.7	Rectification welding	Qualification of WPS and Welder	Major	Performance Test	100%	WPS PQR	WPS PQR	Qual. Record	1	2		
2.8	Stress Relieving	Time/Temp Chart	Major	Measuring Time / Temp.	100%	Each casting	BA75020 R03	Time/Temp Chart	1	2		

  
 L.B. KARNAT  
 Engineer (E-00101000)  
 Quality Assurance



FIRST ANGLE PROJECTION (ALL DIMENSIONS ARE IN MM)

DRAWING NO. 3-61-010-03439/S SHEET 1/1

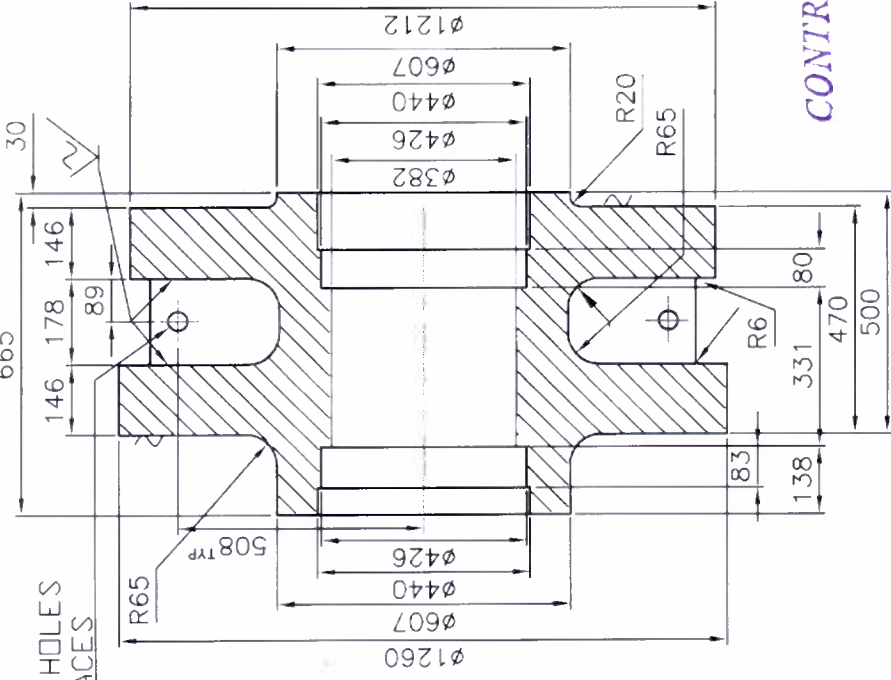

CONTROLLED COPY

SECTION "A-A"

**BHARAT HEAVY ELECTRICALS. LTD.**  
**CENTRAL FOUNDRY FORGE PLANT**  
 RANIPUR HARDWAR

DEPTT. - F.DY. TECHY	SCALE	WEIGHT IN KG.	NAME	SIGN	DATE
		2990 KG			
TITLE			DRN	WGD	CHD
JOURNAL HOUSING (ROUGH MACHINED CASTING)			/37/37089S	SD	SD
PROJECT AND CUSTOMER NAME			APPD.	SD	SD
TECHNOLOGY NO.			T.DAVE	SD	SD
DRAWING NO.			3-61-010-03439/S		
BHBL.			NO. OF SHEETS		

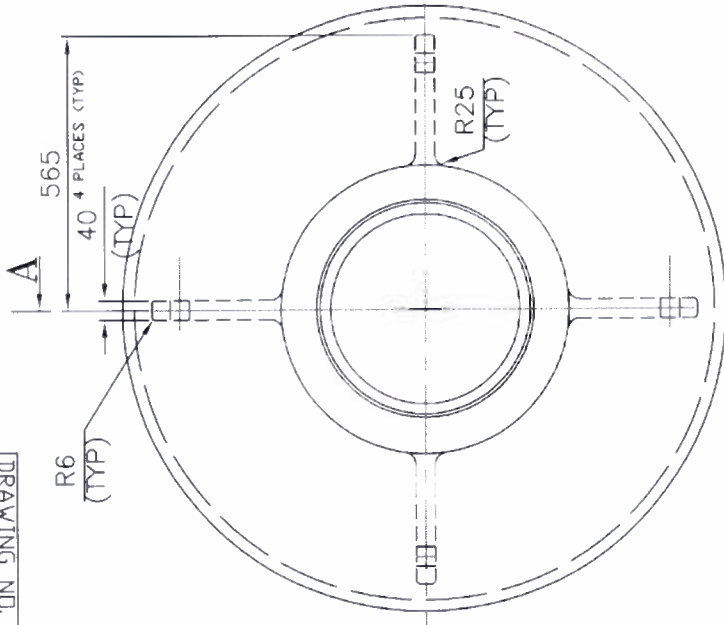

- NOTES:
- 1) DRAFT ALLOWANCES MAY BE ADDED TO CASTING DIMENSIONS WHERE REQUIRED.
  2. CASTING TO BE SUPPLIED IN ROUGH MACHINED CONDITION WITH SURFACE FINISH OF 12.5 MICRONS, TO THE DIMENSIONS SHOWN, AND TOLERANCE OF +2 ON OD AND HT AND -2 ON ID
  3. CASTING SHOULD BE SUPPLIED IN LINE WITH TDC-BA75020 REV 03. HOWEVER NDT CRITERIA & ANNEXURE-D OF THE TDC SHALL NOT BE APPLICABLE. THE VENDOR IS TO DECIDE ITS OWN STRESS RELIEVING TEMPERATURE.
  4. FOLLOWING NDT TO BE CARRIED OUT:  
 UT ON ROUGH MACHINED SURFACE ONLY; AS PER ASTM A609 QL2 FOR THICKNESS UPTO 50 MM AND QL3 FOR THICKNESS ABOVE 50 MM.  
 MP ON ROUGH MACHINED SURFACES ONLY; AS PER AA0850133, ACCEPTANCE AS PER QL2 OF AA0850134  
 4. THE MANUFACTURING PLAN AND QUALITY INSPECTION PLAN IS TO BE SUBMITTED BY VENDOR AS PER THE REQUIREMENT OF TDC BA75020.

TD-106-1 Rev No. 5	Form No. 	<b>PRODUCT STANDARD</b> <b>PULVERISERS</b> <b>HYDERABAD</b>	<b>Product STD NO.</b>	BA 75020				
			Rev No 03					
			Page 1 of 8					
<u><b>TDC FOR CRITICAL STEEL CASTINGS OF BOWL MILLS</b></u>								
<p><b>1. GENERAL :</b></p> <p><b>1.1 SCOPE AND FIELD OF APPLICATION</b></p> <p>The purpose of this specification is to define the required quality and the general manufacturing and inspection conditions for critical steel castings of bowl mills.</p> <p><b>2. CHEMICAL ANALYSIS AND MECH. PROPERTIES</b></p> <p>The Chemical composition and Mechanical properties should be as per AA19511. (Latest Edition)</p> <p><b>NOTE:</b></p> <ul style="list-style-type: none"> <li>- The dimensions and number of test ingots shall be sufficient to allow specimens to be taken for test, retests and, if necessary, reworking.</li> <li>- For each unsatisfactory test, 2 retests shall be performed. In the event that one of the retests is not satisfactory, reworking by new heat treatment is possible.</li> </ul> <p><b>3. GENERAL MANUFACTURING CONDITIONS:</b></p> <p><b>3.1 GENERAL</b></p> <p><b>3.1.1</b> Execution of the items shall be in compliance with drawings and bills of material and with this specification.</p> <p><b>3.1.2</b> To meet the dimensional accuracy, soundness and surface condition requirements for the items, pouring shall be done in a rigid mould.</p> <p><b>3.1.3</b> The temperatures and durations of all the heat treatments shall be recorded and the recordings shall include the references of the items to ensure their traceability.</p> <p><b>3.1.4</b> Material will be supplied in Normalized condition.</p> <p><b>3.1.5</b> The manufacturing procedure is to be followed in the following sequence</p> <ul style="list-style-type: none"> <li>• Casting , fettling</li> <li>• Normalizing</li> <li>• Keel Block Identification / stamping</li> <li>• Keel Block Cutting</li> <li>• Rough Machining</li> <li>• NDT Checks</li> <li>• Repair (If Necessary) and repeat NDT after repair.</li> <li>• Stress Relieving with the Keel Block</li> <li>• Mechanical test</li> </ul>								
<table border="1" style="width: 100%; border-collapse: collapse;"> <tr> <td data-bbox="175 1803 734 1937">           Revisions :            Refer table of revisions         </td> <td data-bbox="734 1803 989 1937"> <b>Prepared By</b>             SG         </td> <td data-bbox="989 1803 1252 1937"> <b>Approved By</b>             JGK         </td> <td data-bbox="1252 1803 1516 1937"> <b>Date :</b>             09.06.2005         </td> </tr> </table>					Revisions : Refer table of revisions	<b>Prepared By</b>  SG	<b>Approved By</b>  JGK	<b>Date :</b>  09.06.2005
Revisions : Refer table of revisions	<b>Prepared By</b>  SG	<b>Approved By</b>  JGK	<b>Date :</b>  09.06.2005					

**COPYRIGHT AND CONFIDENTIAL**  
 The information on this document is the property of BHARAT HEAVY ELECTRICALS LIMITED.  
 It must not be used directly or indirectly in any way detrimental to the interest of the company.

30

ID-106-1 Rev No. 5	Form No.		<b>PRODUCT STANDARD</b>		Product STD no	BA 75020
			<b>PULVERISERS</b>		Rev No. 03	
			<b>HYDERABAD</b>		Page 2 of 8	

COPYRIGHT AND CONFIDENTIAL  
 The information on this document is the property of BHARAT HEAVY ELECTRICALS LIMITED.  
 It must not be used directly or indirectly in any way detrimental to the interest of the company.

- 3.1.6 The castings shall be stress relieved to the cycle as per Annexure D
- 3.1.7 Any weld repair carried out after the final stress relief will be followed by additional stress relief at the specified temperature and time.
- 3.1.8 All the mechanical tests shall be done subsequent to the final stress relieving operation.
- 3.1.9 Mechanical test specimen will undergo all the stress relieving operation as the original material.
- 3.1.10 In case of thin shelled castings additional stress relief may be necessary before final machining to avoid distortion due to relieving of machining stresses.
- 3.1.11 In case the test specimen represents multiple pieces, the mechanical test specimen will undergo all the stress relieving operation corresponding to the piece subject to the additional relief as per clause 3.1.6.

**3.2 REPAIRS**

**3.2.1 SURFACE DEFECTS**

- 3.2.1.1. Surface defects detected on the items in the rough machined state during the non destructive inspections (visual examination, magnetic particle inspection) can be eliminated by grinding within the limit of the dimensional tolerances indicated on the drawings.
- 3.2.1.2. No surface excavation after final machining is accepted.

**3.2.2 REPAIR WELDING:**

- 3.2.1.1. Other defects outside the criteria including internal defects can be repaired by welding to bring the items into compliance with the inspection criteria.
- 3.2.1.2. A qualified repair welding procedure must previously have been drawn up in accordance with ASME IX.
- 3.2.1.3. A map of major defects shall be drawn up before repair.
- 3.2.1.4. Repaired and neighbouring zones shall be given the same inspection as before (see Annexure A), together with an ultrasonic inspection with separate angle probe and transceptor (or with a suitable close field) to detect any planar defect.
- 3.2.1.5. POST WELD STRESS – RELIEVING TREATMENT:

After welding, the items shall be given stress relieving heat treatment as per Annexure D.

**3.3 MARKING:**

- 3.3.1 The material attestation details shall be hard punched with 10 mm punch (min) at a place remaining as-cast unless otherwise specified in the drawing.
- 3.3.2 The following indications shall be included:
  - a) Pattern or drawing number.
  - b) BHEL vendor code.

97

TD-106-1 Rev No 5	Form No. 	<b>PRODUCT STANDARD</b> <b>PULVERISERS</b> <b>HYDERABAD</b>	<b>Product STD no</b>	<b>BA 75020</b>	
			Rev No. <b>03</b>		
			Page <b>3</b> of <b>8</b>		
<p style="writing-mode: vertical-rl; transform: rotate(180deg);">COPYRIGHT AND CONFIDENTIAL The information on this document is the property of BHARAT HEAVY ELECTRICALS LIMITED. It must not be used directly or indirectly in any way detrimental to the interest of the company.</p> <p style="text-align: right;">c) Heat number (to be quoted on all inspection documents) d) Material specification BA75020+AA19511 REV. e) Manufacturer monogram/initials shall not be cast on the casting.</p> <p><b>3.3.3</b> The marking shall be surrounded by yellow paint to make it clearly visible.</p> <p><b>4. GENERAL INSPECTION CONDITIONS:</b></p> <p><b>4.1 GENERAL</b></p> <p><b>4.1.1</b> The first time a type of item is made, the first casting shall be considered a prototype, but it will not be necessary to wait for the results of the inspections at the rough-machined stage before continuing with the manufacture of the other item.</p> <p><b>4.1.2</b> The Quality Control Plan or manufacturing and associated inspection programme shall be drawn up. It shall indicate all the manufacturing operations in chronological order and all the inspections.</p> <p><b>4.2 TESTS AND INSPECTIONS</b> The tests and inspections to be performed on the castings are as in Annexure A.</p> <p><b>5. DOCUMENTS:</b> To be submitted to BHEL after manufacture and before shipment:</p> <ul style="list-style-type: none"> <li>a. Chemical analysis certificates</li> <li>b. Mechanical test certificates</li> <li>c. Heat treatment Charts (Normalizing and Stress relieving)</li> <li>d. Map of defects (defectogram) before repair.</li> <li>e. Dimensional records</li> <li>f. Non-destructive inspection certificates.</li> </ul> <p>All of these documents shall be gathered together to form the constructor file, with a table of contents and cover pages.</p> <p><b>6. ENCLOSED.</b> The following Annexure are enclosed to this specification:</p> <ul style="list-style-type: none"> <li>Annexure A - Test &amp; Inspection</li> <li>Annexure B - Magnetic particle test criteria</li> <li>Annexure C - Ultrasonic Test Criteria.</li> <li>Annexure D - Stress Reliving Cycle.</li> </ul> <p><b>7. PACKING AND TRANSPORT</b> The castings shall be packed suitably and transported to avoid transit damage</p>					

TD-106-1  
Rev No. 5

Form No.



**PRODUCT STANDARD  
PULVERISERS  
HYDERABAD**

**Product  
STD no** BA 75020

Rev No. 03

Page 4 of 8

**ANNEXURE –A**  
**TEST AND INSPECTION**

Type of Inspection	Ref	Method of Inspection	Acceptance Level/Criteria	Inspection Frequency	Support Document	BHEL Scope
Keel Block Identification	--	Stamping before removal	--	100%	--	W
Chemical analysis	AA19511	Standard	The result shall comply the spec	Each item	Certificates	V
Mechanical	AA19511	Standard	The result shall comply the spec.	Each item	Certificates	W
Surface		Visual	The surface shall be free from the defects like cracks or other defects detrimental to the item.	Each casting		W
Dimensions	Drawing	Dimensional	As per drg.	Each casting	Dimensional report	W
Ultrasonic (in Delivery condition)	BS EN 12680-2	BSEN 12680-2	BSEN12680-2 Level 1- Rim Level 2 - Core (Refer Annexure C)	Each item	Certificates	W
MPI (In delivery condition )	AA0850133	Annexure B	1. Transition radii linear & aligned defect level 01. 2. Non-linear defect level 2 except cracks. 3. Cracks and hot tears are not permissible. 4. All rest level 2 5. Planar defects after repair by welding are not permissible.	Each casting	Certificate	W

COPYRIGHT AND CONFIDENTIAL  
The information on this document is the property of BHARAT HEAVY ELECTRICALS LIMITED,  
It must not be used directly or indirectly in any way detrimental to the interest of the company.



**PRODUCT STANDARD  
PULVERISERS  
HYDERABAD**

<b>Product STD no</b>	<b>BA 75020</b>
<b>Rev No.</b>	<b>03</b>
<b>Page 5 of 8</b>	

**ANNEXURE B**  
**MAGNETIC PARTICLE TEST CRITERIA- STEEL CATINGS**

Equivalence ASTM E 125		--	2		
LEVEL		01	02		
Size of the indication taken into account		0.3	2		
Non-linear indications (2)	Maximal whole area (sq. mm) (1)		35		
	Maximal individual size (mm)	1	4 (3)		
Ordering of indications		Isolated or Cumulated	Isolated	Cumulated	
Linear and aligned indications (2)	Maximal lengths of indications (mm) (1)	Thickness of Casting $t < 16$ mm	1	4	6
		Thickness of Casting $16 < t \leq 50$ mm	1	6	10
		Thickness of casting $t > 50$ mm	2	10	16

COPYRIGHT AND CONFIDENTIAL  
 The information on this document is the property of BHARAT HEAVY ELECTRICALS LIMITED.  
 It must not be used directly or indirectly in any way detrimental to the interest of the company.

- (1) In a frame of 105 x 148 mm (Corresponding to ISO/DIN A6 size).  
 (2)

The indication is **linear** if  $L > 3 I$  - Where  $L$  : length and  $I$ : width of the indication.  
 The indication is **Non linear** if  $L \leq 3 I$

If there are 3 or more indications (either linear or non linear) are arranged one behind other at a distance  $\leq 2$ mm, they are called **aligned indication**.

The length taken into account for this purpose is the distance between the beginning of the first indication and the end of the last one.



If more than one defect is located inside a circle of diameter 3 times the pore diameter, the defects are to be considered as a **cluster**.

The length of the defect (The size of the defect in cluster) is taken corresponding to the outer edges of the farthest aligned (or clustered defects)



- (3) 2 Indications Max. For this size in a single frame (ISO A6)

**NOTE:**

- The frequency distribution and the size of the defects will roughly corresponding to the sketches as per Appendix-A of DIN 1690 Part 2
- Hot Tears, Cracks and planer defects are not permitted.

**REFERRED DOCUMENTS :-**

BHEL SPEC NO: AA0850133, DIN 1690-2.



25

TD-106-1  
Rev No 5

Form No



# PRODUCT STANDARD PULVERISERS HYDERABAD

Product  
STD no BA 75020  
Rev No. 03  
Page 7 of 8

COPYRIGHT AND CONFIDENTIAL  
The information on this document is the property of BHARAT HEAVY ELECTRICALS LIMITED.  
It must not be used directly or indirectly in any way detrimental to the interest of the company.

## ANNEXURE - D

### STRESS RELIF CYCLE FOR CASTINGS

- 1.0 **TYPE OF FURNACE** – Electrical, Oil or gas fired.
- 2.0 **TEMPERATURE CONTROL** - The temperature of the furnace should be maintained within  $\pm 14^\circ\text{C}$  during the operation.
- 3.0 **TEMPERATURE MEASUREMENT:** Thermocouple should be placed at 1 meter intervals to ensure uniformity of temperature.
- 4.0 **LOADING** – care should be exercised to ensure
  - 4.1 No direct impingement of flame on the components
  - 4.2 Sufficient space is maintained between components to ensure uniform heating.
  - 4.3 Components are supported to avoid distortions.
- 5.0 The stress relieving cycle to be followed for the casting is

Maximum Ruling section Thickness (Thk)	Heating rate Max ( $^\circ\text{C} / \text{Hr}$ )	Holding Temperature ( $^\circ\text{C}$ )	Min Holding time (Minutes)	Max Holding Time (Minutes)	Cooling rate Max ( $^\circ\text{C} / \text{Hr}$ )
< 12 mm	80 - 100	600 – 650	30	60	80
13– 100 mm	50	600 – 650	2.5 x Thk	4 x Thk	50
> 100 mm	50	600 – 650	150 + Thk	4 x Thk	50

- 6.0 Initial temperature of the furnace before the heating cycle commences may be at  $400^\circ\text{C}$  maximum.
- 7.0 The temperature difference between zones during heating should be less than  $100^\circ\text{C}$  in any 4 meter length.
- 8.0 The specified cooling rate to be followed till the furnace is brought down to at least  $400^\circ\text{C}$ . Subsequently the components may be cooled preferably in furnace. In case air cooling is resorted to, necessary care should be exercised to avoid forced/ unforced air drafts.
- 9.0 The SR Chart must document the instrument calibration records, positioning, and the record of the charge.
- 10.0 The soaking temperature limits to be maintained for all components of a lot if components of various ruling sections are clubbed together in a single heat treatment charge.





16

EVALUATION AND ACCEPTANCE STANDARD FOR  
MAGNETIC PARTICLE EXAMINATION OF CASTINGS

1.0 SCOPE:

1.1 This standard is applicable for Magnetic Particle Examination of Castings.

1.2 The procedure adopted for this examination is as per Corporate Standard AA 085 01 33

2.0 DEFINITION OF INDICATIONS:

2.1 Circular indications are those more or less elliptical with major axis not more than three times the minor axis.

2.2 Linear indications are those having length in excess of three times average width.

2.3 In-line indications are those in group of three or more indications aligned side by side in line with intervening gaps of less than 2mm measured edge to edge.

3.0 EVALUATION OF INDICATIONS:

3.1 Discontinuities and defects will be indicated by the retention of magnetic particles. All such indications are not necessarily defects, since exclusive surface roughness, magnetic permeability variations and machining marks may also produce similar indications.

3.2 Any indication suspected to be non-relevant is to be considered relevant till it is proved otherwise.

3.3 Broad areas of particle accumulation which could mask indications or discontinuities are unacceptable and those areas shall be cleaned and re-examined.

3.4 Relevant indications are those which results from unacceptable mechanical discontinuities.

4.0 ACCEPTANCE STANDARD:

5.1 Castings are classified into four levels as detailed below according to the size and number of flaws permissible.

CONFIDENTIAL AND CONFIDENTIAL  
The information on this document is the property of BHARAT HEAVY ELECTRICALS LIMITED.  
It must not be used directly or indirectly in any way detrimental to the interest of the company.

Revisions

Date

Approved: INTERPLANT NON-DESTRUCTIVE TESTING COMMITTEE

Prepared	Issued	Date
Corp. R&D	CORP : R & D	10 SEPT 79



COPYRIGHT AND CONFIDENTIAL  
The information on this document is the property of BHARAT HEAVY ELECTRICALS LIMITED.  
It must not be used directly or indirectly in any way detrimental to the interest of the company.

Level	No. & size of acceptable indications per 100 sq. cm. area and length not exceeding 25 cm.	Unacceptable indications.
1	2 Nos. of 3mm long indication.	Cracks & hot tears.
2	3 Nos. of 3mm long indication. One of 5mm long indication.	-do-
3	3 Nos. of 3mm long indication. 2 Nos. of 4mm long indication. One of 6mm long indication. One in line indication of - (10mm Max. lgth. )	-do-
4	4 Nos. of 3mm long indication. 3 Nos. of 4mm long indication. 2 Nos. of 8mm long indication. One in line indication of - (15mm Max. lgth. )	-do-

Note: The minimum permissible distance between any two or more acceptable individual flaws shall not be less than the major dimension of the larger flaw.

15 ✓