

BHARAT HEAVY ELECTRICALS LIMITED
ELECTRONICS DIVISION
MYSORE ROAD, BANGALORE - 560 026

Tender Enquiry No.:BHEL:EDN:SHP:PKG:2018-20:ENQ Date: 19.07.2018

1.0 NOTICE INVITING TENDER FOR PACKING

Bharat Heavy Electricals Limited (BHEL), Electronics Division, Mysore Road, Bangalore – 560026 herein invites application from experienced and reputed Packing Contractors for packing work of its products for a period of Two years. The Contractor, on selection, shall comply with various laws under Contract Labour (R&A) Act, Payment of Minimum Wages Act, ESI Act, PF&MP Act while undertaking the contract of packing work as per our specifications, terms and conditions, using Contractor's material, Labour and Tools etc. **The packing works have to be carried out both at BHEL-EDN at Mysore Road Bangalore – 560 026 and at BHEL-ESD at Electronic City, Hosur Road, Bangalore - 560100.**

Complete details of Tender for Packing is hosted on www.bhel.com, www.bheledn.com & www.tenders.gov.in and can be directly downloaded and used for submission of tender document. **OR the Tender documents can be collected directly from o/o SDGM(SHIPPING) , BHEL –EDN ,MYSORE ROAD, Bangaore – 26 at free-of cost.**

Date of issue: Tender documents will be issued from Shipping Dept. of BHEL-EDN, Bangalore from 09.00 hours to 15.00 hours 19.07.2018 to 10.08.2018 on all working days, and from 09.00 hours to 11.00 hours on Saturdays. (Ph: 26998845/9449869625)

Last date for receipt of completed tender documents: 10.08.2018 up to 1.00 PM. Technical bid will be opened at 1.30 PM on the same day, in the presence of bidders desirous to be present.

TENDER NOTIICE

1. Tender Enquiry No. : BHEL:EDN:SHP:PKG:2018-20:ENQ
Dated 19.07.2018
2. Nature of the Work : Rate contract for packing of BHEL products. Viz. CE Panels, Semi-conductor Devices & Photovoltaic Modules, HVDC Thyristor modules, other equipment and associated components.
3. Contract Period : Two Years.
4. Contract Total Value : Rs. **16.84** Crores (Estimated value)
4. Issue of Tender : **From 19.07.2018 to 10.8.2018** on Monday to Friday 9.00 hrs to 15.00 hrs, and on Saturdays 9.00 hrs to 11.00 hrs.
5. Nature of Tender/ bid : **2 Part Bid**
6. Earnest Money Deposit [EMD]: Rs. 15 Lakhs (As per clause no. 3.6.1)
7. Last Date and Time for the receipt of completed Tender. : **10.08.2018 up to 1.00 PM Hours**
8. Date , Time and Place of Tender Opening : **10.08.2018 at 1.30 PM near Reception Tender Opening Room [Technical Bid only]. Price Bid will be opened for technically acceptable bidders on intimation at later date.**
09. Places where packing job to be carried out : 1] BHEL-EDN Mysore Road Bangalore and 2] BHEL-ESD Electronic city, Hosur Road, Bangalore.
- 10.This NIT Document contains : 31 No.of sheets including this Sheet.

Sd/-
For and on behalf of
Bharat Heavy Electricals Limited
Electronics Division
Bangalore - 560 026

(SDGM-SHIPPING)

Table of Contents

Sl. No.	DESCRIPTION	Page Nos.
1	Notice Inviting Tender for Packing	1- 2
2	About BHEL	3
3	Instructions to Tenderers , statutory liability and Obligations	4-17
4	Minimum Qualifying Criteria for selection in techno commercial Bid	18
5	Scope of work and Tender Specifications	18
6	Other Technical points	19
7	General Terms and Conditions	21
8	Commercial Terms and Conditions	25
9	Appendix	31

2.0 About BHEL

Bharat Heavy Electricals Limited, is engaged in the design, engineering, manufacture, construction, testing, commissioning and servicing of a wide range of products and services for the core sectors of the economy, viz. Power, Transmission, Industry, Transportation, Renewable Energy, Oil & Gas, and Defence. We place strong emphasis on innovation and creative development of new technologies aimed at improving the performance and efficiency of our products, using state-of-the-art technologies and processes. We are strongly customer oriented and are sensitive to their needs and accordingly strives to respond quickly to the changes in the market. The high level of quality & reliability of our products is due to adherence to international standards by acquiring and adapting best technologies and practices across the world. Among other, we have been accredited to Quality Management Systems (ISO 9001:2008), Environmental Management Systems (ISO 14001:2004) and Occupational Health & Safety Management Systems (OHSAS 18001:2007).

3.0 Instructions to Tenderers, Statutory Liability and Obligations

Contractors experienced in packing works of similar nature may please submit your offer in two parts in separate sealed covers as detailed below and both the sealed covers are to be put into one big sealed cover as mentioned below super scribed with tender reference as “Techno-Commercial Bid for Packing of CE, SC&PV Products, HVDC Thyristor modules and associated components- Tender Reference No. BHEL:EDN:SHP:PKG:2018-20:ENQ”:

[3.1.1] First envelope shall contain the following:

- a. **Techno-Commercial bid** A questionnaire (as per clause 9.0) duly filled and signed along with all relevant certificates(copies) and documents as per the questionnaire and EMD shall be as per clause no.3.6.1. Enclosures as required by the Tender and any other documents which the Tenderer wish to submit also shall be enclosed. **All the pages of questionnaire, certificates, documents shall be signed / self attested by authorized representative of your company.**

- b. **Unpriced Price Bid - A copy of the price bid without the prices.**

This “Unpriced Price bid” is required for technical evaluation of the relevant portion of the work, desired to be executed by the contractor. Please indicate in the “unit rate” column ‘YES’ for the job you have quoted in Price bid, and ‘No’ for the jobs you have not quoted. Also indicate the applicable SGST/CGST in terms of percentage. (No values shall be quoted in “Unpriced Price bid”).

- c. **Declaration letter**

Declaration that you have gone through the entire tender document, and that you have understood all the clauses of the tender, and shall be abided by the tender clauses while executing the contract.

[3.1.2] Second envelope containing the Price Bid only

Price Bid duly filled & signed with seal must be submitted in another **separate sealed envelope** super scribed with tender reference as “**Price Bid for Packing of CE, SC&PV Products and associated components - Tender Reference No. BHEL:EDN:SHP:PKG:2018-20:ENQ**” DUE ON : .

Price Bid must contain the following details:

- Material cost [Basic Value] for each unit rate for supply of finished shooks/boxes along with required accessories and consumables required as per the specifications.
- Applicable SGST/CGST amount shall be indicated.
- Applicable SGST/CGST amount on packing service charges shall be indicated.
- Cost to be indicated by multiplying unit rate & unit quantity.
- Bid should be free from correction, overwriting, using corrective fluid, etc. Any interlineation, cutting, erasure or overwriting shall be valid only if they are attested under full signature(s) of person(s) signing the bid else bid shall be liable for rejection.
- Non conformities between the figures and words of the quoted prices:-
 - (a) If, in the price structure quoted for required goods, there is discrepancy between the unit price and the total price (which is obtained by multiplying the unit price by the quantity), the unit price shall prevail and the total price corrected accordingly, unless in the opinion of the purchaser there is an obvious misplacement of the decimal point in the unit price, in which case the total price as quoted shall govern and the unit price corrected accordingly.
 - (b) If there is an error in a total corresponding to the addition or subtraction of subtotals, the subtotals shall prevail and the total shall be corrected; and
 - (c) If there is a discrepancy between words and figures, the amount in words shall prevail, unless the amount expressed in words is related to an arithmetic error, in which case the amount in figures shall prevail subject to (a) and (b) above.

If there is such discrepancy in an offer, the same is to be conveyed to the tenderer with target date on the above lines and if the tenderer does not agree to the observation of the purchaser, the tender is liable to be ignored.

[3.1.3] Sealed envelope of both (1) Techno-Commercial bid and (2) Price bid must be put in a single sealed larger envelope super scribed with Tender reference and due date must be sent within the specified date and time and be dropped in the Tender Box earmarked for "Shipping Dept." which is kept at Reception Counter, BHEL-EDN, MYSORE ROAD, BANGALORE-560026 on or before the due date & time of tender.

Important Note

[3.1.4] All the pages of the tender document shall be signed and stamped by the authorized representative of vendor.

[3.1.5] IMPORTANT POINTS:

- i Price bid will be opened only for those technically qualified for the quoted items.
- ii Please, do not spiral bound the pages, send them in 2 hole clips flat files.
- iii Give annexure numbers to all enclosures, and indicate serial numbers for all the pages & put your signature & seal at the bottom of each and every page.
- iv Send your offer with a covering letter on your company's letter head.
- v If you are attaching a document which is not in English but in other local language, please attach an English translated page along with that.
- vi BHEL reserves the right to call for additional information and/or check, verify all the information furnished in the application.
- vii BHEL also reserves the right to inspect all premises/facilities to confirm the authenticity of information furnished / capabilities mentioned in the application.
- viii BHEL reserves the right to reject any or all the applications which are not as per tender terms with assigned any reasons within the norms.
- ix BHEL's decision shall be final on all the matters relating to this tender.
- x Taxes quoted by you will be taken for GST credit. The taxes prevailing as on the date will be considered. However, in case of changes made by the Government from time to time, the same will be considered during the progress of contract for payment and claim purposes. In case, no Tax is included, a self declaration for exemption may be attached along with the offer.
- xi In this regard, if any clarification is required, the Tenderers may contact the officer mentioned here below.
- xii Tenders should be addressed only to:

**SDGM - Shipping
BHEL, Electronics Division,
Mysore Road, Bangalore – 560 026.
Phone: 080-26998373/26998845.**

- xiii All the entries in the Tender Documents should be in one ink. Erasures and over- writings are not permitted. Cancellations and insertions if any, shall be authenticated by the tenderer by signing and affixing his seal.
- xiv Tenderer shall fill in all the required particulars in the blank spaces provided in the Tender documents and also sign at the bottom of each and every page of the Tender document before submitting the Tender.
- xv In quoting their rates, the Tenderers are advised to take into account all factors including any fluctuations in the market rates for materials, wages for your employees, transportation charges etc. in the future.

xvi The rates quoted in the Tender shall remain valid for a period of three months from the date of opening of the bid.

xvii Before submission of Tender, the Tenderers are necessarily advised to inspect the site of work and its environment and be well acquainted with the actual working and other prevailing conditions including various best practices adopted by BHEL with respect to position of the materials and labor here. Pre-bid meeting deliberating the aspects involved in the contract can be arranged on request to ensure proper understanding by the Tenderers who wish to participate. The bidders are expected to be well versed with BHEL-General Conditions of Contract (GCC), Instructions to Tenderers, specifications and all other documents, which form part of the Agreement to be entered into subsequent to award of work.

xviii Details and quantities of each item of work shown in the Tender schedule attached hereto are only approximate. They are given as a guideline for the purpose of Tendering only and are liable to variations and alterations at the discretion of the competent authority throughout the contract period from the date of commencement of work. The work under each item as executed shall be measured and paid at the corresponding rates to be quoted by the Tenderer in the Tender schedule Format attached hereto.

xix The Packing work shall normally be done between 7.30AM and 4.36 PM on working days. However, the same shall be done beyond normal working hours on the directions of executing officers whenever the work load is temporarily increased. No overtime wages or additional payments or allowance for you or your employees deployed for such work will be payable by BHEL for working beyond normal working hours.

[3.1.5] **PERIOD OF CONTRACT:** This contract will be for a period of Two years from the date of award of contract. BHEL shall have absolute right to terminate the contract at any time during the period of contract without assigning any reason thereof and the tenderer is not entitled for any compensation on the ground of such termination.

[3.1.6] **DISQUALIFICATION:** If the bidder/contractor attempt to do any act, which defames the goodwill of BHEL it will be treated as disqualification of the party and the contract will be terminated at any time. The offers received from any bidder who had been convicted or against whom any kind of criminal cases are pending on complaint, will not be considered.

[3.2] CONTRACTOR'S STATUTORY LIABILITY:

Contractor shall comply all statutory requirements with the provisions of all the applicable Acts, Central or State, and Rules made thereunder, particularly in respect of Factories Act 1948, Child Labour Prohibition Act 1986, Employer's Liability Act, 1938, Industrial Disputes Act 1947, Minimum Wages Act 1948, Payment of Wages Act 1936, Employee's Compensation Act 1923, Payment of Gratuity Act 1972, ESI Act 1948, the Contract Labour [Regulation & Abolition] Act 1970, Payment of Bonus Act 1965, Income Tax Act 1961, Maternity Benefit Act 1961, applicable Tax Rules & other Acts -Central or State and Rules, Regulations and Notifications by the concerned authorities thereto and amendments made thereunder from time to time along with other statutory obligations and relevant labour laws that may be applicable to him in relation to employment of his labourers, payments etc. and service Tax rules and all other applicable Acts and rules issued from time to time shall be complied with by the contractor. The Contractor shall apply and obtain License under the Contract Labour (R&A) Act 1970, and comply with the relevant provisions, in respect of the Labour employed by him for executing this Contract. The Contractor shall furnish necessary returns to the authority through the principal employer.

[3.2.1] PAYMENT OF PRESCRIBED MINIMUM WAGES: Contractor shall ensure payment of prescribed minimum wages as applicable to his employees deployed in the work, as BHEL - EDN may notify from time to time and maintain proper records of their timely disbursement. BHEL Rates Notified during last 3 years periods taking into account average consumer Price Index is given below (the details given below is indicative of the past trend only):

Category	Wages per day				
	From 01/04/2014	From 01/04/2015	From 01/04/2016	From 01/04/2017	From 01/04/2018
USW	331.91	397.68	413.00	427.13	439.26
SSW	345.88	419.35	434.67	448.79	460.92
SW	362.63	443.19	458.51	472.63	484.76
HSW	380.62	469.47	484.79	498.92	511.11

USW=Unskilled ,SSW=Semi-skilled , SW=Skilled , HSW= Highly skilled labour

[3.2.2] WELFARE MEASURES: As a welfare measure towards his workers who may be deployed under this contract, the Tenderer must consider Rs.40/- per

day per person for Transport Allowance, Rs.10/- per day per person towards Attendance Bonus, Washing Allowance @ Rs.125 per month per person and take it into account in your estimate and the quoted rate shall be inclusive of the above incentives/allowances as well.

BHEL reserves the right to advise the contractor to extend any further welfare facility in future for the employees of the contractor (over & above the wage rates envisaged as mentioned above i.e., existing wage structure and also allowances as above) on reimbursement basis with additional service charges from BHEL.

The workmen engaged under this contract shall be provided with 2 pairs of their factory uniform (the color of the uniform should be different from BHEL uniform and the uniform of labors under job contract in BHEL) per annum with stitching charges, 2 pair of shoes covering 2 years period, 4 pairs of socks covering 2 years period, 1 no. of Toilet soap per person per month by the contractor of which the cost shall be included in his quoted unit rates.

[3.2.3] **COMPLIANCE WITH ESI / PF LAWS:** Contractor should ensure that the employees allowed to enter BHEL premises shall be covered under independent code numbers under EPF Act 1952 and ESI Act 1948 and shall cover his employees under the Employees Provident Fund schemes and Employees State Insurance Act 1948 and show proof of payment of subscriptions/contributions to the concerned authorities. The contractor shall also indicate ESI No., PF No., GST No. in the techno-commercial bid if available. In case the contractor do not have the ESI & PF Code while quoting, he should immediately apply for the same after award of the contract and get it in a reasonable time. Contractor shall ensure payment of ESI contribution under ESI Act 1948 and provide ESI membership No. card of each employee. Contractor shall maintain proper records of PF, EDLI, Pension, ESI contribution, administrative charges etc., wherever applicable and shall produce proof of deductions as well as remittances. Contractor shall issue wage slips to his employees. Contractor shall furnish proper Returns to the concerned statutory authorities and provide a copy of the same to BHEL. These returns shall be subject to verification whenever the statutory authorities/ inspectors visit BHEL for inspection of records of the contractors.

Contractor shall be solely responsible for non-payment / delayed payment of wages / allowances, contributions under EPF, ESI Act etc. The basic rates to be quoted by the Tenderer shall be firm for material, labor and shall cover and include all statutory levies and contribution such as ESI, PF etc payable by the contractor for the workers he may deploy to carry out the job. In case, the contractor fails to make payment of wages to his employees or remittance of contribution to the concerned authorities & a claim is made against BHEL for what so ever reason, the security deposit /other dues/ running bills under the contract can be utilized by BHEL to discharge the liability of the contractor.

[3.2.4] **INDEMNITY:** Contractor shall indemnify BHEL against all claims and losses if it suffers under various labor laws, statutes or any civil or criminal law in connection with employees deployed by him. The liability for any compensation on account of injury sustained by an employee of the contractor will be exclusively that of the contractor, as BHEL is not the employer for him. Contractor shall obtain necessary insurance cover at his own cost to mitigate any risk of accidents, losses, damages etc. BHEL shall not be responsible for any losses, damages to the contractor or to his employees.

Payment of bonus under the Payment of Bonus Act, payment of gratuity under the Payment of Gratuity Act, and retrenchment compensation under ID Act will be the sole responsibility of the contractor. Contractor is liable to pay the statutory bonus to their employees, as per Payment of Bonus Act. In case, BHEL advises the contractor to pay any additional amount of Bonus to their workers over and above the statutory bonus, the same has to be paid by the contractor to their employees. The difference, in such an event, can be reimbursed from BHEL with indicated additional service charges.

[3.2.5] Bonus: Bonus @ 8.33% limited to Rs.7000/- payable by the contractor for the workers he may deploy to carry out the job (Under various enactments passed by Parliament or the by the State legislature and Rule framed thereunder). In case, BHEL advises the contractor to pay any additional amount of Bonus to their workers the same has to be paid by the contractor to their employees. The difference, in such an event, can be reimbursed from BHEL with indicated additional service charges.

[3.2.6] **FACTORIES ACT:** Contractor shall observe provisions of Factories Act in respect of working hours, holidays, rest intervals, leaves and overtime to his

employees, who may be deployed in BHEL premises & maintenance of necessary registers, forms and statutory formats which shall be always available for inspection by BHEL or Factory Inspectorate. No work shall be done on second / third shift, overtime, Sundays or on other declared holidays without written permission from BHEL. Over and above the daily wages rate, the contractor shall make payment to his employees deployed under this contract towards leave with wages also. Contractor shall be responsible for making payment of wages before expiry of 7(seven) days from the last day of wage period and to ensure disbursement of wages in the presence of the representative from BHEL.

[3.2.7] **FAILURE OF CONTRACTOR:** In case the contractor does not carry out the contractual / statutory obligations or the services rendered by him are found to be unsatisfactory, BHEL shall bring the same to his notice and he will be obliged to discharge the obligations and rectify the deficiency / anomaly within three days time failing which, BHEL reserves the right to terminate the contract without assigning any reason whatsoever. In such an event, no damages will be payable for short closure of the contract and the contractor shall be liable to BHEL for any loss or hardships it may suffer, such termination shall be for the contractor's default and any money including deposits or bills available with BHEL will be forfeited and any further claim on the contractor may be made by BHEL for recovery of any loss. The decision of BHEL regarding interpretation of any terms and conditions set forth in this agreement shall be final and binding on the contractor.

[3.3] Contractor's Obligations:

Contractor shall decide the number of workmen to be deployed for execution of the work awarded to him and he or his authorized representative will be solely entitled to instruct such workers about the manner in which the awarded work is to be carried out as per the prescribed specifications and as may be directed by Engineer-In-charge. The contractor shall provide Employment certificate to his workmen and also shall obtain License in terms of statutory Regulations from Labour Authorities for enabling him for such work. The Contractor shall be fully responsible for the work awarded to him and shall depute a supervisor to supervise work to be carried out by his workmen. The work shall be executed as per work instructions to the satisfaction of Engineer-In-charge. Contractor shall maintain appropriate records of his employees deployed to carry out the job(s). Contractor will be fully responsible for the good conduct of his employees deployed to execute the work. In case of any

misconduct/ misbehavior by any employee, the contractor will replace such employee(s) immediately. The contractor shall be responsible for ensuring that all precautions are taken for safety of his employees and in enforcing all safety regulations as applicable by strictly ensuring wearing of safety equipments by them inside the factory while undertaking the work Tendered. BHEL may provide hand gloves & other safety protective appliances wherever required. The contractor should ensure that his employees deployed in this work wear a neat and tidy distinct uniform, different from BHEL employees having logo of the contractors firm / company. In the event of termination of contract for any reason whatsoever, the contractor shall withdraw all his employees and his equipments, if any; from the establishment of BHEL.

[3.4] Taxes:

In price bid, the bidder shall indicate item wise cost with applicable taxes separately. Accordingly, indicate separately a) basic unit material cost item- wise, b) applicable GST amount for material portion, c) basic unit packing service charges item wise, d) GST amount on packing service charges, wherever applicable.

For cost comparison, the item COST to BHEL as per working Schedule enclosed(Part II-A, B,C, D & E) will be considered. BHEL reserves the rights to alter the procedure / methodology for cost comparison after due verification of applicable credit benefit issues which are relevant to this.

[3.5] Payment Terms:

The Contractor shall submit bills after completion of packing and the payment will be made after receipt of the bill and supporting documents in satisfactory condition.

[3.5.1] Methodology for Bills raising:

[3.5.1.1] Delivery Challan: At the time of supply of packing materials by contractor the Delivery challan(DC) will be duly verified by Security personnel and counter signed by user dept. No payment will be made on these supplies till completion of packing. Original DC will be retained at shipping.

This delivery challan/bill shall contain the following (it has to be all inclusive):

- Date and number of the delivery challan.
- Name, address and GSTIN of the consigner,
Name, address and GSTIN or Unique Identity Number of the consignee,
- HSN code for the goods.
- Description of goods. (Details of Packing shooques sizes with quantity, area or volume as applicable and value shall be as per contract shall be indicated)
- Quantity of goods supplied
- Taxable value of supply.

- GST tax rate and tax amount broken down as CGST, SGST, IGST – where the transportation is for supply to the consignee.
- Place of supply (in case of inter-state movement of goods.)
- Signature

Payment for consumables as per Part – II D shall be made upon supply after due receipt and verification.

[3.5.1.2] **Packing Bill:** After completion of the packing work, the vendor shall submit bill for packing material and packing service charges as per rate contract item wise and relevant GST.

The invoice shall be in accordance with the Work Order (WO) duly supported with documents as called in the WO and shall contain BHEL WO No and WO Schedule, WO Item no. and Description, Quantity, Rate.

Terms & Conditions to be complied under GST regime:

1. All invoices to contain BHEL-EDN (buyer) GSTIN number: 29AAACB4146P1ZB
2. The Bidder shall mention Bidder's GSTIN number, HSN (Harmonized System of Nomenclature), SAC (Services Accounting Code) mandatorily in all quotations and Invoices submitted
3. Invoice submitted should be in the format as specified under GST Laws viz., all details as mentioned in Invoice Rules like GST registration number(GSTIN), invoice number with date of issue, quantity, rate, value, taxes with nomenclature – CGST, SGST, UGST,IGST mentioned separately, HSN Code / SAC Code etc. Invoice should be submitted in original for buyer plus duplicate for credit availment.
4. Vendor to upload the GST Invoice details in the GSTN Portal for BHEL to avail credit in time
5. Payment of GST to Vendor will be made only if it is matching with data uploaded by the Vendor in GST portal.
6. In case GST credit is delayed/denied to BHEL due to non/delayed receipt of goods and/or tax invoice or expiry of timeline prescribed in GST law for availing such ITC, or any other reasons not attributable to BHEL, GST amount will be recoverable from vendor along with interest levied/ leviable on BHEL.
7. In case vendor delays declaring such invoice in his return and GST credit availed by BHEL is denied or reversed subsequently as per GST law, GST amount paid by BHEL towards such ITC reversal as per GST law will be recoverable from vendor/contractor along with interest levied/ leviable on BHEL.
8. Vendor should intimate BHEL immediately on the same date of invoicing without any delay.
9. Bidders to note that Rules & Regulations pertaining to E-way bill system are to be strictly adhered to.

10. Credit note to be provided for any disallowance / mismatch , pending which GST payment will be on Hold.

11. Give an undertaking that GST as mentioned in the invoice has been paid/will be paid either through cash or admissible input credit and also file the returns.

[3.5.1.4] Tender Evaluation and Award of contract : BHEL reserves the right to split the quantity and Award the Contract to more than one vendor. Contract will be awarded to a maximum of 5 contractors for each schedule (ie. Part II-A, B,C, D & E) of work.(BHEL reserves the right to limit the allocation to less than 5 contractors also). If required; BHEL will negotiate with the vendor who is L1 for each **schedule** as above, and then counter offer the negotiated L1 rates to other vendors from L2, L3, L4 etc., till a maximum of 5 contractors are available for each schedule. The proposed ratio from L1 to L5 for awarding the contract on L1 rates/negotiated L1 rates will be approximately as follows:

	L1	L2	L3	L4	L5
Lx	% age	% age	% age	% age	% age
L1	100				
L1,L2	60	40			
L1,L2,L3	50	30	20		
L1 TO L4	40	30	20	10	
L1 TO L5	30	25	20	15	10

[3.5.1.5] In addition to the above, the Packing work entrusted to each contractor depends on the following criteria, during the execution of the contract:

- (i) The Number of Workmen employed.
- (ii) Stock of Packing Materials supplied and kept at our works, by the Contractor at any point of time.
- (iii) Performance of the Contractor and timely completion of the work.
- (iv) Readiness of the Contractor to take-up the job at short notice and to meet our monthly schedule that will be issued periodically.
- (v) Raising to the occasion, during peak loads.

3.6 EARNEST MONEY DEPOSIT & SECURITY DEPOSIT

Earnest Money Deposit and Security Deposit will be as per the tender documents.

3.6.1. Earnest money deposit (EMD):

The tenderer shall furnish the EMD of Rs. 15,00,000/- (Rupees Fifteen Lakhs only). Exemption of EMD can be availed by genuine MSE vendors as per guidelines of MSMED act 2006 and public procurement policy for MSME, 2012 by ministry, government of India.

3.6.1.1. Modes of deposit

The EMD may be accepted only in the following forms:

- (i) Electronic Fund Transfer credited in BHEL account (before tender opening)
- (ii) Banker's cheque / pay order / Demand draft, in favour of BHEL (along with offer)

3.6.1.2. Forfeiture of EMD

EMD by the Tender will be forfeited as per NIT condition, if:

- i) After opening the tender and within the offer validity period, the tenderer revokes his tender or makes any modification in his tender which is not acceptable to BHEL.
- ii) The contractor fails to deposit the required Security deposit or commence the work within the period as per LOI/ Contract.

EMD by the tenderer shall be withheld in case any action on the tenderer is envisaged under the provision of extant "Guidelines on Suspension of business dealings with suppliers/ contractors" and forfeited/ released based on the action as determined under these guidelines.

3.6.1.3. EMD given by all unsuccessful tenderers shall be refunded normally within fifteen days of award of work.

In case of expiry of offer validity period or any other circumstances, EMD can be released with the approval of Head of Contracting deptt., not below the rank of AGM.

3.6.1.4. EMD shall not carry any interest.

3.6.1.5.. EMD of successful tenderer will be retained as part of Security Deposit.

3.6.1.6. Please note that MSE suppliers can avail the intended benefits only if they submit along with the offer, attested copies of either EM II certificate having deemed validity (five years from the date of issue of acknowledgement in EM II) or valid NSIC certificate or EM II certificate along with attested copy of a CA certificate (format is given below where deemed validity of EM II certificate for five years has expired) applicable for the relevant financial year(latest audited).Date to be reckoned for determining the deemed validity will be the date of bid opening(part I in case of two part bid). Non submission of such documents will lead to consideration of their bid at par with other bidders. No benefit shall be applicable for this enquiry if any deficiency in the above required

documents are not submitted before price bid opening. Documents should be notarized or attested by a Gazetted officer.

3.6.1.8

CA CERTIFICATE FORMAT

Annexure - I

Certificate by Chartered Accountant on letter head

This is to Certify that M/S
(hereinafter referred to as 'company') having its registered office at
is registered under MSMED Act 2006, (Entrepreneur
Memorandum No (Part-II) dtd:.....,
Category: (Micro/Small). (Copy enclosed).

Further verified from the Books of Accounts that the investment of the company as per the latest audited financial year as per MSMED Act 2006 is as follows:

1. **For Manufacturing Enterprises:** Investment in plant and machinery (i.e. original cost excluding land and building and the items specified by the Ministry of Small Scale Industries vide its notification No.S.O.1722(E) dated October 5, 2006 :
Rs.....Lacs
2. **For Service Enterprises:** Investment in equipment (original cost excluding land and building and furniture, fittings and other items not directly related to the services rendered or as may be notified under the MSMED Act, 2006:
Rs.....Lacs

(Strike off whichever is not applicable)

The above investment of Rs.....Lacs is within permissible limit of Rs.....Lacs forMicro / Small (Strike off which is not applicable) Category under MSMED Act 2006.

Or

The company has been graduated from its original category (Micro/ Small) (Strike off which is not applicable) and the date of graduation of such enterprise from its original category is (dd/mm/yyyy) which is within the period of 3 years from the date of graduation of such enterprise from its original category as notified vide S.O. No. 3322(E) dated 01.11.2013 published in the gazette notification dated 04.11.2013 by Ministry of MSME.

Date:



(Signature)

Name -

Membership number -

Seal of Chartered Accountant

3.6.2 Security deposit

Security Deposit means the security provided by the Contractor towards fulfilment of any obligations in terms of the provisions of the contract.

3.6.2.1 The total amount of Security Deposit will be 5% of the contract value. EMD of the successful tenderer shall be converted and adjusted towards the required amount of Security Deposit.

3.6.2.2 Models of deposit

The balance amount to make up the required Security Deposit of 5% of the contract value may be accepted in the following forms:

- i) Local cheques of Scheduled Banks (subject to realization)/ pay order/ Demand Draft/ Electronic Fund Transfer in favour of BHEL
- ii) Bank Guarantee from Scheduled Banks /Public Financial Institutions as defined in the Companies Act. The Bank Guarantee format should have the approval of BHEL
- iii) Fixed Deposit Receipt issued by Scheduled Banks/ Public Financial Institutions as defined in the Companies Act (FDR should be in the name of contractor, A/c BHEL)
- iv) Securities available from Indian Post offices such as National Saving Certificates, Kisan Vikas Patras etc. (held in the name of contractor furnishing the security and duly endorsed/ hypothecated/ pledged, as applicable, in favour of BHEL)

(Note: BHEL will not be liable or responsible in any manner for the collection of interest or renewal of the documents or in any other matter connected therewith).

3.6.2.3 Collection of Security:

At least 50% of the required Security Deposit, including the EMD, should be paid before start of the work. Balance of the Security Deposit can be paid by deducting 10% of the gross amount progressively from each of the running bills of the Contractor till the total amount of the required Security Deposit is collected.

If the value of work done at any time exceeds the contract value, the amount of Security Deposit shall be correspondingly enhanced and the additional Security Deposit shall be immediately deposited by the Contractor or recovered from payment/s due the Contractor.

The recoveries made from running bills (cash deduction towards balance SD amount) can be released against submission of equivalent Bank Guarantee in acceptable form, but only once, before completion of work, with the approval of the authority competent to award the work.

3.6.2.4. Security Deposit shall be released to the Contractor upon fulfilment of contractual as per terms of the contract.

3.6.2.5. The Security Deposit shall not carry any interest.

4. Pre Qualification Criteria for Selection in Techno-Commercial Bid

4.1 Experience of having successfully completed similar works during last 7 years ending last day of month previous to the one in which applications are invited should be either of the following:-

a. Three similar completed works costing not less than Rs.300 Lakhs

Or

b. Two similar completed work costing not less than Rs.375 Lakhs.

Or

c. One similar completed work costing not less Rs.480 Lakhs

4.2 Tenderer should have experience in packing of similar products of BHEL – EDN, Mysore Road, Bangalore, using rubber wood / ply wood / pine wood / carton boxes as on tender due date. The experience in packing shall be for the corresponding items (Rubber wood / Ply wood / pinewood / Silver Oak wood/ Carton Box) for which they have quoted. Experience certificate or PO/Work Order copy shall be furnished and the date of issue of certificate/PO/Work order shall be minimum one year prior to tender due date.

4.3 Tenderer should have average annual financial turnover of Rs.225 Lakhs during the last three financial years (Year 2015-16, 2016-17, 2017-18).

4.4 The Tenderer should have a legal status such as that of a Proprietary concern/ Partnership firm/ Company.

4.5 The tenderer should have manufacturing facility / Supply facility for the items (Rubber wood/Ply wood/pine wood/Silver Oak wood/Carton Box) for which they have quoted.

5.0 Scope of work and Tender Specification

The scope of work covers Packing of CE Panel, Semi-conductor Devices, Photovoltaic Modules and associated components and equipment in BHEL EDN, Mysore Road premises as well as at BHEL-ESD, Electronics city premises as per applicable packing plant standards and product standards of BHEL.

5.1 TENDER SPECIFICATION(Guidelines and Procedure).

Part - I: A) Technical Specification (Guidelines and Procedure) for Packing of Control Equipment Products, Semi-Conductor Devices etc. as per BHEL-EDN Plant Standard

No. ED 049 00 99 Rev 13 (Enclosed as part of Tender).

Part - I: B) Technical Specification Guidelines and Procedure for Packing of Control Equipment Products, Semi-Conductor Devices, HVDC Thyristor Modules etc. using Plywood as per BHEL-EDN Plant Standard No. ED 049 00 92. Rev 08 (Enclosed as part of Tender)

Part - I: C) Technical Specification for Packing of Solar PV Modules. Packing Procedure and Drawing for PV Modules(L20220P & L24270P). (Enclosed as part of Tender)

Part – II

Items list for Packing and supply:

- A] Schedule of quantity for Control Equipment Products, Semiconductor Devices etc. using Rubber Wood / Silver oak wood / Pine wood.
- B] Schedule of quantity for Packing of Control Equipment products, semiconductor Devices, HVDC Thyristor modules etc. using Plywood of different Grades.
- C] Schedule of quantity for Packing of PV Modules in Cartons.
- D] Schedule of quantity for consumables for packing to be supplied by the Contractor.
- E] Schedule of quantity for Packing of Panels and other items with GI sheet.

6.0 OTHER TECHNICAL POINTS

6.1 Quality of Materials

6.1.1 The Quality of materials used for Packing shall be as per I.S. Specification / BHEL Specification for each material. Each item (Eg:- Silica Gel, Kraft Paper etc.) is subject to inspection and approval by BHEL before the same is used. Any disapproved / non-standard item identified by BHEL shall be removed by the Contractor.

6.1.2 Species of Wood & extent of Chemical treatment will be subject to random check at least ONCE in a year at any reputed Laboratories. The Contractor is bound by the reports of these Laboratories. The charges towards testing are to be borne by the contractor.

6.1.3 The Contractor shall submit a certificate confirming the quality of wood supplied by him and the Chemical treatment done is as per the Tender Specification.

- 6.1.4 If, for any reason, Rubber Wood / Silver Oak Wood / Pine wood is not available on a particular occasion, other wood considered equivalent to Rubber Wood/Silver Oak / Pine wood may be used with prior written permission from BHEL.
- 6.1.5 Handling of markings on the cases/panels have to be done using templates / stickers and suitable indelible inks. These have to be provided by the contractor at their cost.

6.2 Calculation of Wood content for the purpose of payment for Rubber wood / Pine wood / Silver oak wood packing.

For Calculation of Wood content for the purpose of payment BHEL will consider

- 6.2.1 For Cubicles and Panels using Rubber wood, Silver oak wood and Pine wood, Length X Breadth X Thickness of FRONT, REAR, TWO SIDES & TOP PLANKS only will be calculated as bare volume, for panels without pallet. Pallet will be supplied by BHEL as part of Panel.
- 6.2.2 Length x Breadth x Thickness of Bottom Pallet will be Considered as bare volume if it is supplied by the Contractor.
- 6.2.3 In case of loose items packed in boxes including bottom pallet, all Six side Planks / shooks will be considered for calculation of bare volume.
- 6.2.4 The Volume of the following wood will be considered while calculating total wood content for the purpose of billing / payment.
- i. Reinforcing battens
 - ii. Support battens
 - iii. Beams given to the bottom side / pallet etc.

To take care of machining loss on account of tongue and groove and planning, 20 percentage of the bare volume will be added to the bare volume calculated as per 6.2.1, 6.2.2 and 6.2.3. This means for calculation of total volume of wood content, 1.2 times of bare volume of 6.2.1, 6.2.2 and 6.2.3 only is considered.

6.3 Calculation of Wood content for the purpose of payment for Plywood Packing

- 6.3.1 In case of Packing of Cubicles with plywood, as per PART-I 'B' of Tender Specification, Calculations will be based on Area of Front, Rear, 2 sides and Top Planks only. For this, Payment will be made based on Square Area as described in the Schedule of Rates under Part – II 'B'. Pallet will be supplied by BHEL. Whenever pallet is supplied by contractor, area of the same will be considered for payment also. For spares and loose items cases, pallet will be supplied by the contractor.
- 6.3.2 Area of additional reapers, supporting battens and reinforcing battens will not be considered for payment of packing charges. **Hence the costs of these battens necessarily have to be included in the cost of main plywood area along with**

other packing materials. Separate charges or rates are not allowed since payment for plywood rates are based on square meter of plywood content i.e., Total area of plywood planks used as per 6.3.1, above.

- 6.3.3 In case of bottom pallets supplied by the contractor, payment will be made on Area of wood content. The calculation is same as at 6.3.1. Additional reinforcement plywood sheet, if used, will be paid extra.
- 6.4 The Dust on the Loose Items & inside and outside the Cubicles shall be removed by the Contractor's workmen before Packing.

7.0 GENERAL TERMS AND CONDITIONS.

1. The Contractor shall take, at his own cost, the necessary License in respect of his Trade/Business, in respect of this work. The expenses in completing the formalities in executing the agreement including expenses on Stamp Paper, will also be met by the Contractor.
2. Except where otherwise provided for in the contract all questions and disputes relating to the meaning of the Specifications, Designs, Drawings and Instructions herein before mentioned and as to the quality of workmanship or materials used on the work or as to any other question, claim, right, matter or thing whatsoever in anyway arising out of or relating to the Contract, Designs, Drawings, Specifications, estimates, Instructions, orders or these conditions or otherwise concerning the works or the execution or failure to execute the same whether arising during the progress of the work or after the completion or abandonment thereof shall be referred to the sole arbitration of the Arbitrator who would be appointed by BHEL from the panel of arbitrators of Bharat Heavy Electricals Limited., If the said arbitrator is unable or unwilling to act, the same would be referred to some other person appointed from such panel willing to act as such arbitrator who will be the Sole arbitrator. There will be no objection if the arbitrator so appointed is an employee of Bharat Heavy Electricals Limited, Electronics Division and that he had to deal with the matters to which the contract relates and that in the course of his duties as such he had expressed views on all or any of the matter in dispute or difference.

It is a terms of the contract that the party invoking arbitration shall specify the dispute or disputes to be referred to arbitration under this clause together with the amount or amounts claimed in respect of each such dispute.

The work under the Contract shall if reasonably possible continue during the arbitration proceedings and no payment due or payable to the Contractor shall be with-held on account of such proceedings.

The arbitrator shall be deemed to have entered on the reference on the date he issues notice to both the parties fixing the dates of the first hearing.

The arbitrator shall give a separate award in respect of each dispute or difference referred to him.

The venue of arbitration shall be such place as may be fixed by the arbitrator in his sole discretion.

The award of the arbitrator shall be final, conclusive and binding on all parties to this contract.

3. The BHEL General conditions of Contract shall also apply to this work, except to the extent modified in these conditions. The Contractor shall scrutinize the GCC available in BHEL-EDN and acquaints himself with the provisions thereof, to his satisfaction.
4. Failure to employ adequate number of persons, or failure to supply required qty of packing materials, resulting in dislocation of the work will be construed as breach of the terms and conditions under this agreement, and will entail termination of the Contract forthwith and re-arrangement of the work through other agencies, at the risk and cost of the Contractor.
5. Cleanliness has to be maintained by the Contractor's workmen in the Packing/Dispatch Area. Scrap materials to be removed and Shop floor of Shipping Section to be kept clean at the end of each day. Cut Pieces / Scrap belonging to Contractors materials to be removed and taken back with necessary paper works after duly certified by concerned executive.
6. The Management of BHEL shall have the right to with-hold Payment of, or make recoveries from claims due to them in respect of any loss or damage caused or occasioned in respect of the properties of BHEL under the Terms and Conditions of this arrangement or any payments necessitated due to infringement of any statutory obligations, by the Contractor.
7. The Contractor shall not transfer or sublet the work to anyone without the prior written approval of BHEL. The Contractor shall, either by himself or through a competent Agent approved by BHEL Authorities, perform the said work.
8. Whenever under the Contract any sum of Money shall be recoverable from, or payable by the Contractor, the Contractor on demand shall pay the same. Such amount may also be deducted from any sum then due, or from any sum which at any time thereafter become due, to the Contractor under this Security Deposit, in respect of this work or in respect of any other work.
9. All the employees of the Contractor engaged for the work shall be paid by him their normal wages, for the National Holidays and Public Holidays declared by BHEL for that Calendar year.
10. Without prejudice to any rights or remedies under this Agreement if the Contractor dies/becomes insolvent/bankrupt/wound-up, the BHEL authorities shall have the right to terminate this agreement without any liability whatsoever as regards enlistment of the work for the balance Contract period after the death/ insolvency/bankruptcy/winding up of the Contractor.
11. In the event of the Contractor committing a default or breach of any of the provisions of the contractor's Labour Regulations, as amended from time to time or furnishing any information or submitting or filling any Form / Register / Slip under the Provisions of these regulations which is materially incorrect, then, on the report of the Inspecting officers as defined in the Contractors Labour Regulations, the Contractors shall, without prejudice to

any other liability, pay to BHEL, a sum not exceeding 10% of contract value as liquidated damages for every default, or furnishing, making, submitting, filling materially incorrect statement as may be fixed by BHEL. Such amount will be deducted from the running Bills/Security Deposit of the Contractor and the amount would be credited to the Welfare Fund constituted under Regulations.

12. **Model Rules for Labour Welfare:-**

The Contractor, at his own expense comply with or cause to be complied with Model Rules and Labour Welfare as appended to these conditions or rules framed by Government from time to time for the protection of Health of the Labourers. In case, the contractor fails to make arrangements as aforesaid BHEL will be entitled to do so and recover the cost thereof from the Contractor.

13. The Contractor should take full care regarding safety aspects. In case of any Accidents / Injuries to the Contractor's Labourers within the premises of the Company (BHEL), the Contractor is solely responsible and no claims whatsoever on the Company (BHEL) is permissible.

14. Successful tenderer should provide the following safety Personal Protective items to his labourers during working period and shall ensure safe working habits and safe working conditions. All these expenditures have to be borne by the tenderer only. **BHEL will not reimburse the same.**

**Sl. No. Personal Protective. Eqpt. - qty:
/ Items**

- | | | | |
|----|----------------------|----------|------------------|
| 1. | Safety spectacle | - 1 no | |
| 2. | Ear Muff | - 1 no | Makes & Specifi- |
| 3. | Ear Plug | - 1 set | cation as per |
| 4. | Dust Mist respirator | - 1 no | enclosed Sheet. |
| 5. | Hand gloves | - 1 pair | |

Indicated approximate cost of these safety items excluding Shoes will be approx. Rs.800/-.

15. The Contractor shall be equipped to pack at least 4 Cubic Metres of Wood content or equivalent to 10 Cubicles of Control Equipment Products per day.

16. In case there is any delay in completion of the job as referred above, Company will be at liberty to levy penalty on the Contractor at the rate of 0.01% of the total value of equipment to be packed per day of delay subject to a maximum of 1%.

17. The Company does not give any Guarantee on minimum work load during the Day / Month / Year. The workload varies within the Month and within the year.

18. In case of emergency, if the contractor fails to do the packing work within the stipulated time, the same will be got done elsewhere / through others. Penalty may be levied on the Contractor as applicable.
19. In case it is found that the species of Wood/ASCU treatment do not conform to the Specification, Penalty not exceeding 10% of the value of the packing cost of that packing work will be levied and deducted from the monthly bill.

In addition, the Company (BHEL) will have the option to terminate the Contract.
20. The Contractor and his workmen shall abide by the Rules relating to maintenance of discipline and Security checks of the Company.
21. All Tools, Equipments, required for Packing shall be supplied by the Contractor which will be returned after closure of the contract duration.
22. Packing of Small Boxes for Speed Post, R.P.P. Airfreight, Personal Carry, if done with BHEL material labour charges will be paid as per contract rate for labour charges for respective items.
23. If any Packing material individually is required, the Contractor shall supply these at rates offered as per Schedule 'D' of Part – II –Rate Schedule
24. All Tools, Equipment and Materials brought by the contractor shall be shown to the security at gate and to be entered in the Register kept in the Security Department and DCs are to be preserved by the contractor to take back the items at a later date.
25. The Tenderer should submit EMD as per clause 3.6.1.1 along with Technical Bid (If not exempted as per MSME guidelines). Offer without EMD shall be rejected.

26. The Tenderers should have categorically confirmed acceptance of all the Tender terms and condition including the payment terms. In case of non-compliance / non-conformity, the offer is liable for rejection.

27. Tender Committee decision is final for evaluation and acceptance of techno-commercial Bid, taking into account information furnished by the tenderer, visit to the tenderers works, documents verification etc.
28. Tenderer should have facility, infrastructure and man power to execute the order for which they have opted for quoting.
29. The tenderer should not have blacklisted by any Public Sector Undertaking / Public Departments.
30. Tenderer should have facility, infrastructure and man power to execute the order.
31. BHEL reserves the right to adopt Reverse Auction or standard Price Bid Opening procedure for price evaluation, at its discretion. This shall be decided after completion of techno-commercial evaluation of tender (Refer BHEL website http://www.bhel.com/vender_registration/vender.php for Guidelines of Reverse Auction). In

case BHEL does not resort to Reverse Auction, the price bids and price impacts (if any) already submitted and available with BHEL shall be opened as per BHEL's standard practice.

8.0 COMMERCIAL TERMS AND CONDITIONS

EARNEST MONEY DEPOSIT

- a] The Tenderer shall furnish Earnest Money Deposit.(Please refer clause 3.6.1 & 3.6.1.8, in case of exemption from EMD).
- b] Tenderer shall furnish Earnest Money Deposit in the Form of Bank Demand Draft in favour of BHARAT HEAVY ELECTRICALS LTD., ELECTRONICS DIVISION, BANGALORE. This Demand Draft shall be submitted along with the Techno-commercial Bid. Offers not accompanied by EMD will be rejected.

The EMD given by unsuccessful Tenderers will be returned after the Tender is finalized. EMD amount shall not carry any interest. EMD amount can also be adjusted towards the Security deposit.

8.1. SECURITY DEPOSIT:-

a] Successful Tenderer will have to furnish Security deposit. The amount will be decided based on the work order being given to each of the successful tenderer after Award of Contract. [As per clause 3.6.2 above]

b] The Security Deposit may be furnished in the form of Cash / Bank Draft / Bank Guarantee immediately after the award of the Contract. Earnest Money Deposit already received would be returned on receipt of Security Deposit as above. The Security Deposit will be released / returned after the successful completion of the Contract. The Security Deposit shall not bear interest. This Security Deposit will be forfeited and credited to BHEL in the event of breach of any of the Terms and Conditions of the Contract by the Contractor.

8.2.1. The Security Deposit shall be paid by the vendor before start of the work by the vendor.

8.2.2. Security Deposit may be furnished as per clause no.3.6.2.

8.3. TERMS OF PAYMENT:

8.3.1 The Contractor shall submit bills after completion of packing and the payment will be made after receipt of the bill and supporting documents in satisfactory condition.

8.3.2 All statutory deductions under Income Tax Act or any other Law will be deducted by the BHEL as per rate in force.

8.3.3 The Company is not bound to accept the lowest Tender and decision of the Management of the Company is final. No reasons, whatsoever will be given by the Company for not accepting the offer of any Tenderer.

8.3.4 The Tender shall be kept valid for acceptance by BHEL up to 3 months from the date of opening of Bid. Tenderers will not be allowed to alter the Prices during the validity period.

8.3.5 The Company may short close / cancel the Contract if the Performance of the Contractor is found unsatisfactory.

9.0 Techno Commercial Bid

Tenderer Data (Technical bid) - Questionnaire

Questionnaire - Data to be filled in by the Tenderer i.e., sl.no .9 with all relevant documents and sealed in cover super scribing as "**TENDER FOR PACKING - Techno Commercial Bid - Questionnaire** " and required to be dropped in the Tender Box.

QUESTIONNAIRE

A. DATA TO BE FILLED BY THE TENDERER

Note: The question with mark 'M' is Mandatory

1. Name in Full under which :
the Tenderer is trading [M]

2. Address of the Official :
Premises [M]
 - a) Office:
 - b) Works :

3. Telephone No. [M]
 - a) Office :
 - b) Works :
 - c) Residence of Partner / Proprietor / Director.

4. Registered as: Public Limited Company/Private Limited Company / Partnership firm/Proprietary Company [M]
(Strike whichever is not applicable)

5. Names & Address of : i)
Proprietor/Partners
/Directors if any ii)
iii)

iv)

6. Details of Saw Mill [M] :

a) Is the plot on which Saw Mill / workshop is situated owned /leased by you.

b) Are the Materials and Machinery & Building Insured against Fire etc.

c) Area of the Plot :

d) Size of the Building :

e) Details of Machines and associated facilities.

i)

ii)

iii)

iv)

v)

vi)

f) No. of Labourers employed at the Mill.

g) No.of Laborers shall be deployed at BHEL-EDN for Packing works.

h) Since how long are you running the said Mill / workshop?.

7. Have you obtained permission? from Karnataka Forest Dept. to run the Saw Mill.(**If applicable**)

OR

(Alternatively have you got No Objection Certificate from Karnataka Forest Department to run the Saw Mill.(**If applicable**)

8. Please furnish the following:
Registration Nos. (Copies of certificates to be necessarily enclosed)

a) Shops & Establishment Act
Registration No.

b) Forest License No.(If applicable) :

c) PAN No: [M] :

d) GSTN.:

9. Does your firm have Independent Code Nos. in respect of following and if yes, mention the same.

a) Employees State Insurance Act 1948 (ESI) : Yes / No
-Code No.

b) Employees Provident Fund Act 1952 (EPF) : Yes / No
-Code No.

10. Your Banker's Name & Address :

11. a) Your Annual Financial " Turn Over "
For

2015 - 16
2016 - 17
2017- 18

12. a) Experience of having :
successfully completed /
undertaken similar works
during previous 1 Years [M]

b) indicating Names of Clients to whom :

i) Packing Cases are being
supplied by you. [M]

ii) Packing work is being :
done by you. [M]
(Please enclose copies of
Purchase Orders / work orders).

13. Earnest Money Deposit DD details: [M]

a] Bank Draft No. and date :

b] Banker Name :

c] Amount taken : **Rs. /-** []\

14. I / We also read the tender terms and conditions [M] : Yes / No
completely and understood the same.

15. We give our acceptance to supply as per [M] : Yes / No
tender specifications.

16. We hereby give our declaration that we have read the : Yes / No
Tender completely and understood the same. [M]

17. Please give the details of documents enclosed to your offer which include applicable
Registration certificates and other necessary documents to support your techno
commercial bid.

i]

ii]

iii]

iv]

v]

vi]

vii]

viii]

ix]

x]

xi]

xii]

I / We hereby certify that to the best of my/our knowledge, the particulars furnished
above are true. It is understood that the information furnished will be treated as
confidential and will not be divulged to unauthorised persons.

I / We also agree to the General Terms and Conditions & Commercial Terms and
Conditions as per the Tender Notification.

I / We also agree to keep the validity of our Quotation for acceptance for a period of 3
months from the date of opening of the bid.

Date :
Place:

Signature of the Tenderer

NAME:
DESIGNATION:

Appendix

1. Plant Standard ED 049 0092 Rev 08
2. Plant Standard ED 049 0099 Rev 13
3. Un Priced Price Bid Format
4. Price Bid Format
5. PV Packing Box Drawing L24270P -28 IN 1
6. PV Packing Box Drawing L20220P -28 IN 1
7. PLY WOOD RPP BOX DRAWING
8. E P PACKING BOX DRAWING
9. E P PACKING CORNER BLOCK DRAWING
10. RP800 THYRISTOR MODULE SHIPPING DOCUMENTS



A4 - 15

PLANT STANDARD

ED 049 00 92

REV NO 08

Page 0 of 25

REVISION HISTORY SHEET

REV NO.	DATE	NATURE OF CHANGE	REASONS	CHANGED BY	APPROVED BY
00	11/05/1995		-	VS, SHG	N J
01	05/06/1995	ANNEXURE ADDED	ACCEPTANCE CRITERIA INCLUDED FEED BACK FROM QUALITY	SHG	NJ
02	06/03/1997	CL.6.4.1 ALTERED	FEEDBACK FROM SHIPPING	SHG	NS
03	20/12/1999	IS YEAR OF ISSUE REMOVED	-	CCR	NS
04	15/12/2009	INCLUSION OF MR GRADE PLYWOOD SHEET FOR PACKING (Commercial Grade)	FEEDBACK FROM SHIPPING & GENERAL REVIEW	PGD / KPN	MSR
05	21/03/2013	Inclusion of recommendation pertaining to spares in page 12 and 26	Recommendation from Corp System and IT	HRN	MS
06	11/01/2016	Cl 3.1.1.5, 3.8, 3.9, and 3.22 revised	Feedback from Shipping and General Review	HRN /EK Prakash	BKD
07	19/02/16	Page 21 deleted. No. of sheets revised to 25	Feedback from Shipping	HRN/EK Prakash	BKD
08	06/06/18	Clase 3.22 revised by changing unit mm to cm	Feedback from Shipping	BKD	Sathyanarayana

COPYRIGHT & CONFIDENTIAL

The information contained in this document is the property of BHEL. It must not be used directly or indirectly in any manner detrimental to the interest of the company.

APPROVED: M. Sivaramaiah

PREPARED: PGD/KPN ISSUED: STDS GROUP DATE: 15/12/09



PLANT STANDARD

ED 049 00 92

REV NO 08

Page 1 of 25

A4 - 13

PROCEDURE FOR PACKING OF CONTROL EQUIPMENTS USING PLYWOOD.

1. **PURPOSE:** To describe the materials and procedure for Packing.
2. **SCOPE:** Applicable for packing of control cubicles, loose items, spares of Control Equipment and Transmission System Control products.
3. **MATERIALS**
 - 3.1. **WOOD**
 - 3.1.1 **For Inland contracts:**
 - 3.1.1.1 Plywood of Boiling Water Resistance (BWR) grade and termite, fungus proof as per IS: 303 of 12 mm thick for control cubicles, single and multi cubicles, loose items and spares cases. The plywood shall be bonded with high Quality Phenol Formaldehyde Synthetic Resin and specially treated with preservatives to repel termites and wood destroying organisms. The plywood shall with stand the stress caused by cyclic changes in weather conditions. It shall be durable and resistant to heat, sun and moisture. The sheets such procured shall have IS mark IS 303 and BWR grade stamped on it.
 - 3.1.1.2 Silver oak wood of cross section 45x45 mm as support battens for Loose items, spares and single suit, two suit, three suit Cubicles and 70x45 mm for longer sections to be used. These Silver oak wood battens shall be treated with ASCU solution as defined in 4.0. In the case of plywood, treatment with ASCU solution need not be done.

Alternative to silver oak battens, Plywood support battens of suitable cross section and combination of thickness can also be used as per clause 3.1.1.4

APPROVED : Sathyanarayana

PREPARED:
PGD/KPN

ISSUED:
STDS GROUP

DATE:
15/12/09



A4 - 14

PLANT STANDARD

ED 049 00 92

REV NO 08

Page 2 of 25

3.1.1.3

Plywood for general purposes i.e. moisture resistance or MR grade (Commercial ply wood) and termite, fungus proof as per IS: 303 of 9 mm / 12 mm thick for control cubicles, single and multi cubicles, loose items and spares cases. The plywood shall be bonded with high quality Phenol Formaldehyde Synthetic Resin and specially treated with preservatives to repel termites and wood destroying organisms. The plywood shall withstand the stress caused by cyclic changes in weather conditions. It shall be durable and resistant to heat, sun and moisture. The sheets such procured shall have IS mark IS 303 and MR grade stamped on it. 9 mm thick plywood can be used with additional plywood support/ reinforcement suitable battens both for small cases and also for panels. Support batten as indicated at 3.1.1.4 shall be used.

Sample drawings of panels & loose boxes are attached for ready reference.

[Fig : 10 to 13]

3.1.1.4 Support Battens:

Ply wood sheet of cross section 18 mm x (100 mm) for support batten for loose items, spares, and plywood sheet of cross section 18 mm thk x 100 to 150 mm width as support batten for standard panels up to 2450 x 1350 x 2500 mm panels. Support batten of plywood cross section 12 thk x 75 to 100 mm can also be used for small cases apart from 18 mm x 100 mm cross section. These plywood support battens can also be used in place of silver oak support battens as referred in clause 3.1.1.2. Additional support battens/ cross battens of suitable sizes are to be provided on need basis.

Sample drawings of panel's .i.e. single suit, two suite and three suit cubicles are attached for ready reference [Fig: 10 to 13].

Special support battens for Rlys and similar panels:

Plywood of cross section 18 mm x 75mm x 3 no's at both bottom end and top end of front and back shook's , and also at top portion of both corner shook's for fixing with bolt and nut/ clamps, and 18 mm x 150 mm x 2 nos cross section as support batten/ slanting reinforcement batten on all sides. On need basis 18mm x 125 mm x 2 to 3 no's of plywood cross section can also be used additionally depending upon the size and weight of the panel.

Plywood shook's can be fixed with both Bolts and mechanical latching

A4 - 14

mps or combination of both as the case may be.

Sample drawings of panels are attached for ready reference.
[Fig : 8 & 9]

3.1.1.5 Tolerance of ply wood thickness: Tolerance of plywood for inland packing shall be +/- 1 mm.



PLANT STANDARD

ED 049 00 92

REV NO 08

Page 3 of 25

3.1.2 For Export Contracts

- 3.1.2.1 Plywood of Marine grade as per IS: 710 of 9 / 12 mm Thick for control cubicles of single / two / three suite for loose items and spare cases. For suit of four and longer cubicle sections, 19mm thick is to be used.

It shall be highly resistant to attacks from fungi, termites and wood destroying organisms including marine borers. The plywood shall withstand the stress caused by cyclic changes in weather conditions. It shall be durable and resistant to heat, sun and moisture. The sheet shall have IS: 710 and marine grade marking.

3.1.2.2 Same as clause 3.1.1.2.

- 3.1.3 BHEL_EDN will be carrying out test on ISI marked ply Wood whenever required.

- 3.2 Fasteners: M8 x 130 mm and M8 x 150 long zinc plated Bolts and M8 zinc plated nuts for fixing, and spring Washers or suitable size can also be used.

- 3.3 Nails: Nails of dia 3.15 mm and about 40 mm for nailing of plywood and silver oak batten. Suitable smaller size is to be used for other nailing.

- 3.4 Polyethylene sheet: The polyethylene sheets are used to make covers for the jobs individually. The material shall have a minimum thickness of 0.175 mm (175 microns).

The polyethylene sheet shall be clear and transparent manufactured out of virgin material. Reprocessed material shall not be used.

- 3.5 Bituminised water proof kraft paper - used for lining the inside of shookees of cubicles.

- 3.6 Bitumen coated Hessian polyethylene kraft paper used for lining the inside of top cover for cubicles and all inner and top sides for small boxes.

- 3.7 Rubberised Coirs- used for cushioning and to fill the gap inside packing boxes. The coir shall be about 100 mm wide and 25mm thick.

- 3.8 Foam rubber/U Foam - This is used for covering the delicate items. This material shall be provided by the vendor.

- 3.9 A4 - 14 nocole (Expanded polystyrene) sheets - This is used for covering delicate items. This material shall be provided by vendor.

- 3.10 Silica gel - shall be of indication type to conform to IS: 3401: shall be blue in colour while usage.



PLANT STANDARD

ED 049 00 92

REV NO 08

Page 4 of 25

- 3.11 Cotton bag - These are used for holding silica gel. The bags shall have the following matter indicated on them:

BHEL-EDN

BANGALORE-560026

**SILICA GEL
INDICATING TYPE**

BLUE : ACTIVE

ROSE : REDUCED ACTIVITY

**WHITE : NO ACTIVITY. TO BE REPLACED WITH FRESH
SILICA GEL**

- 3.12 Cotton / Plastic tape-This is used for tying small items and also to prevent vibrations of moving parts within the cubicles.
- 3.13 Polyethylene bags - These are to be used for keeping the packing slips. The bag shall be of size 70 mm X 100 mm (minimum).
- 3.14 Hessian cloth, twine thread, paint will have to be used in packing certain items.
- 3.15 Marking plate - This shall be of anodized aluminium sheet. Details and specifications are given in Fig-3.
- 3.16 Marking ink - Ink used shall be normally black in colour. The ink shall be indelible, non fading and non washable in water.
- 3.17 Packing Slip Holder - This shall be of galvanised iron tinned sheet / aluminium sheet.
- 3.18 Mechanical Latching clamps : For CLW Railway panels and similar Panels self locking clamps can also be used on need basis in conjunction with or apart from regular bolt and nut fixing arrangement. Sample drawing attached [refer Fig.7]. For reusable boxes, these clamps provides easy locking and unlocking arrangement. These clamps will be made available from BHEL in some cases.
- 3.19 Flex/Vinyl digital print media for labeling:
Labels made out of Flex/Vinyl/ other digital media shall be used for export contracts & some prestigious domestic contracts on need basis apart from existing present marking/ labeling system.
- 3.20 Aluminium foil for packing:
On need basis, suitable size & thickness of aluminium foil shall be used for packing of electronic panels and loose items for both indigenous & export contracts.
3. A4-14 ets :
- All cubicles are mounted on the pallets by BHEL. For loose items, HMI items & small cabinets for which no pallets are available, suitable size pallets have to be arranged by the contractor.



PLANT STANDARD

ED 049 00 92

REV NO 08

Page 5 of 25

3.22 : STICKERS The following stickers to be put by the vendor on cubicles/Boxes after packing.

1. Case No sticker : 2 nos. Size 25 cm X 4.5 cm
2. BHEL Monogram sticker : 1 no . Size 17.5 cm X 23 cm
3. Addresss sticker : 2 nos. Size 38 cm X 30 cm
4. Direction sticker " Front " & " Back " - 4 nos .Size 20 cm X 7.5 cm
5. Chain Mark Sticker : 4 Nos. Size - 30 cm X 7.5 cm
6. "Fragile " sticker : 2 Nos Size. 21cm X 15 cm
7. "DO NOT STACK " sticker - 2 Nos. Size 30 cm x 22 cm

4.0 Chemical treatment for silver oak preservation

4.1 The silver oak battens are to be treated with ASCU solution. For plywood wood treatment is not required.

4.2 The chemical used shall be ready mix ASCU paste. This consists of Arsenic, copper sulphate, sodium dichromate. This paste shall be mixed at the rate of 1 kg of paste per 10 liters of water. Alternate to this CCA can also be used as indicated at para 4.4

4.3 The chemical treatment shall be done at the premises of the contractor. A cement concrete tank of capacity to hold a minimum of 2000 liters of solution shall be constructed. The solution shall be prepared in the presence of BHEL- EDN's representative by contractor. The wooden battens shall be soaked in the solution for a minimum of 12 hours.

The solution shall be replenished after treating a maximum of 12 cubic meters of wood for 2000 liters of solution. A log book shall be maintained by the contractor to give the details of date of preparation of solution, quantity of solution prepared, quantity of chemicals used, quantity of wood treated and the details of replenishment.

Samples of solutions [only paste before mixing] shall be tested at the laboratories designated by BHEL. The testing fees to be paid to the laboratories will have to be borne by the contractor. The solution [paste] shall be tested as and when required.

4.4 Specifications for water soluble type wood preservatives:

Copper - Chromium - Arsenic [CCA]:

Copper - Chromium - Arsenic preservative formulation shall be as per IS : 10013 Part - II - 1981 shall consist of following active ingredients in nominal proportions by weight as shown below:

Arsenic Pentoxide	$AS_2O_5 \cdot 2H_2O$	12.5
Copper Sulphate	$CuSO_4 \cdot 5H_2O$	37.5
Sodium Dichromate	$Na_2Cr_2O_7 \cdot 5H_2O$	50.0
Or		
Potassium Dichromate	$K_2Cr_2O_7$	

5.0 Jointing of plywood- to the extent possible, single plywood sheet shall be used in case of equipment of large size, jointing is allowed as bellow.

5.1 The joining shall be as close to the center of equipment as possible, but not less than 500 mm from one edge.



PLANT STANDARD

ED 049 00 92

REV NO 08

Page 6 of 25

5.2 While joining (2 or more plywood sheets), care shall be taken to fix the sheets in the direction of the grain structure.

A4 - 14

5.3a For joining Plywood and Silver oak wooden batten:

While joining, 2 sheets shall be kept close to each other and treated silver oak batten of 100 mm width and 45 mm thick to be used and nailed to both plywood sheets alternately (2 numbers) in zig-zag manner.

5.3b For Joining plywood with plywood sheets :

While joining, 2 sheets shall be kept close to each other and plywood sheet batten of minimum 100 to 200 mm width and 18 mm thick to be used depending upon the size of the box/ case and nailed to both plywood sheets alternately (2 numbers) in zig-zag manner. Suitable size nails to be used.

5.4 Jointing of silver oak batten : Only single length silver oak batten shall be used. In case of height or width of equipment is more than 2400 mm, jointing of batten is acceptable. The jointing of batten shall be such that two batten are kept together and one more batten of width & length of about 200 mm to be nailed on both the planks as in Clause 5.3 above.

5.5 The above jointing is to be done close to center of equipment.

6.0 Packing procedure

6.1 Packing of cubicles for inland contracts.

6.1.1 Packing to be done using materials given in clause 3.0.

6.1.2 The cubicles are fixed on wooden pallets. Hence the contractor need not arrange the bottom pallets.

6.1.3 Loose parts : All loose parts in the cubicles, shall be tied using cotton/ plastic tape. Wooden battens shall be provided wherever necessary.

6.1.4 Additional loose items which may be kept inside the cubicle.

a. The components which are removed from cubicle for loose shipping, such as meters shall be kept inside the cubicle individually kept in wooden box and tied firmly to the bottom of cubicle.

b. Other items which are given loose in addition to cubicle, shall be packed in separate boxes (like cables).

c. For transformer cubicles loose items shall be packed in separate boxes and these boxes may be tied firmly in bottom of cubicles.

d. Items which are bigger in size such as impulse tubes may be kept at the top of cubicles firmly bunched and tied.

6.1.5 Wooden batten : This batten shall be silver oak wood .In case of Cubicle which are not rectangular in shape like control desks,



PLANT STANDARD

ED 049 00 92

REV NO 08

Page 7 of 25

Sufficient number of wooden rafters/ battens of proper size shall be A4-14 added to give strength to the package.

- 6.1.6 Silica gel: Silica gel (as in 3.10) packed in cotton bag (as in 3.11) shall be kept at different place inside the cubicle as per BHEL-EDN directions. Each suit of cubicle shall provided with 1 kg of silica gel (for a suit of 4 cubicles, 4 kg of silica gel shall be used).
- 6.1.7 Polyethylene sheet covering: Cubicles shall be covered with polyethylene petticoat (sheet as in 3.4). This shall be tailor made to fit the cubicle. The sealing shall be such as not to allow any moisture to enter the cubicle. This sheet is to be folded to the bottom pallet with wooden planks on 2 larger sides.
- 6.1.8 After completion of this, the arrangement is as shown in Fig.1.
- 6.1.9 Rubberised coir: (as in 3.7) to be nailed from inner side of plywood after pasting kraft paper for full length with a pitch less than 500mm with a min. of 2 rows of cover is to be used.
- 6.1.10 Bituminised water proof kraft paper: (as in 3.5) to be pasted with glue on 4 inner sides of plywood. Whenever 2 pieces of kraft paper are used, the joint shall have an over lap of min 20 mm.
- 6.1.11 Bitumen coated Hessian polyethylene kraft paper (as in 3.6) to be nailed using nails (as in 3.3) on top cover inner surface. This sheet shall project outside on 4 sides by atleast 100 mm and shall be folded and nailed on to the sides. Joining of 2 sheets shall have an overlap of min 20 mm.
- 6.1.12 After completion of above steps, the arrangement shall be as given in Fig.2.
- 6.1.13 Marking Plate : One no (as in 3.15) shall be nailed to the front side of case, item as shown in Fig.3.
- 6.1.14 Case Marking : After complete packing, marking of various details and symbols as given by EDN shall be done using indelible ink (as in 3.16)
- 6.1.15 Packing Slip : Packing slip kept in polyethylene bag (as in 3.18) shall be placed inside the box at appropriate place before closing the top. in addition one more packing slip covered in polyethylene cover and packing slip holder (as in 3.17) shall be nailed to front or rear of shook.
- 6.1.16 At the end of this stage, the arrangement is as shown in Fig.4. Front and rear shook fixing arrangement to the bottom of the pallet is as shown in Fig.5
- 6.1.17 The lifting arrangement of the packed case is **shown in Fig.6**
- 6.2 Packing of cubicles for export contracts Procedure is same as that given in 6.1 except for the following changes:



PLANT STANDARD

ED 049 00 92

REV NO 08

Page 8 of 25

- Two Polyethylene petticoat (as in 6.1.7) instead of one
- Fumigation may have to be done if required (BHEL Scope).

6.3 Packing of empty Cubicles Procedure is same as that given in 6.1 except For following changes

- Bituminised kraft paper, bitumen coated Hessian polyethylene paper, silica gel need not be used.

6.4 Packing of loose items/spares for inland contracts

6.4.1 All the materials and procedure are same as in 6.1 except that :

- No joining of plywood and silver oak batten
- Inner sides of all 6 sides shall be nailed with bitumen coated Hessian polyethylene kraft paper (as in 3.6) using nails.
- Kraft paper (as in 3.5) is not required
- Silica gel quantity is 100 gm approx per box.
- Rubberised coir is to be nailed to inner surfaces of bottom 4 sides of box.
- Bottom plywood sheet / pallet shall be of 18 mm thick for all practical purposes and 12 mm thick for smaller boxes on need basis. Suitable bottom beams made out of plywood/ any other wood of suitable cross section 75x36 mm, 75x54 mm, 75x75 mm, 100x100 mm.
- Support battens of cross section 12x75 mm, 12x100mm, 18x75 mm, 18x100 mm can be used depending upon the size of the boxes. Plywood support battens can be used in the place of silver oak battens.
- Clause 6.1.10 is not applicable. Individual items to sealed with polyethylene sheet (as in 3.4) and one full cover of polyethylene sheet covering of all items is to be made.

6.4.2 In few cases gabled roof (single or double gable) may have to be made, details of which will be given by EDN.

6.4.3 Internal Packing: Items that go into the box shall be packed using polyethylene sheet/ U foam/ thermocol sheets/air bubbled sheets/ paper cartoons and cotton tape. Any space left between the job and the sides and the top of the box shall be filled with rubberised coir/air bubbled sheet /thermocole to get proper cushioning effect. Certain items like transformers, reactors, breakers, etc shall be bolted to the bottom of the box using bolts, nuts and washers.

6.5 Packing of Loose items/ Spares for Export Contracts: Procedure is same as that given in 6.4 except for following changes:

- Two polyethylene covers to be provided,
- Fumigation may have to be done, if required, for which payment will be made by EDN.

6.6 Any other changes/ new methods/ alternative packing systems can be undertaken with prior information and approval from the dept. For other parameters and further details concerned agency may please be contacted.



PLANT STANDARD

ED 049 00 92

REV NO 08

Page 9 of 25

7.0 ACCEPTANCE CRITERIA OF PLYWOOD :

PLYWOOD FOR GENERAL PURPOSE GRADE FOR PACKING - AS PER IS:303

1. Plywood sheets shall have IS:303 & BWR / MR grade stamped on each sheet.
2. Packing/contractor should give a certificate to this effect.
3. Contractor shall identify each sheet with their name/firm in suitable place.
4. Visual checks to be done by packing contractor and EDN-QC CE shipping.
5. For other parameters, testing will be done at authorised laboratories/institutions by EDN on sample basis.

7.1 FOR BWR GRADE : TABLE-1 QUALITY REQUIREMENTS OF PLYWOOD

S1 NO	Defect Category	Maximum Number of Defect Permitted on any one surface of panel (as applicable to Type A Surface of IS:303)
1.	Blister	Nil
2.	Check	Individual check not more than 50mm in length and the total length not more than 300mm/m ²
3.	Discoloration	Nil
4.	Dote	5cm/m ²
5.	Insect hole	Scattered up to 12 holes/m ²
6.	Joints	One joint for every multiple of 200mm provided no individual piece is less than 100mm in width
7.	Knots (dead)	2 up to 12mm dia/m ²
8.	Pin knots (dead)	2/m ²
9.	Pin knots (live)	No restriction
10.	Knots (tight)	6 up to 25mm dia/m ²
11.	Patches	4 patches/m sq provided they are all tight patches & do not mar the appearance
12.	Splits	2 splits each not more than 1mm wide and length not more than 100mm provided



PLANT STANDARD

ED 049 00 92

REV NO 08

Page 10 of 25

they are filled with suitable filler

13. Swirl Unlimited provided they do not mar the

7.2 FOR MR GRADE : TABLE -2 QUALITY REQUIREMENTS OF PLYWOOD

S1 NO	Defect Category	Maximum Number of Defect Permitted on any one surface of panel (as applicable to Type A Surface of IS:303)
1.	Blister	Nil
2.	Check	Individual check not more than 100mm in length and the total length not more than 1000mm/m ²
3.	Discoloration	5 %
4.	Dote	15cm/m ²
5.	Insect hole	Scattered up to 24 holes/m ²
6.	Joints	: No restrictions
7.	Knots (dead)	4 up to 20mm dia/m ²
8.	Pin knots (dead)	: 6/m ²
9.	Pin knots (live)	No restriction
10.	Knots (tight)	: No Restrictions
11.	Patches	Any number provided they are all tight patches & do not mar the appearance
12.	Splits	3 splits each not more than 4 mm wide and length not more than 150 mm provided they are filled with suitable filler
13.	Swirl	NO restrictions

7.3 Thickness of Plywood sheets:

The plywood boards shall be of uniform thickness within specified tolerance limit specified. The faces of plywood boards shall be reasonably smooth.

7.4 PERMISSIBLE DEFECTS:

Gaps in cores and cross-bands may be permitted except for 3 ply plywood, provided the width of the gap does not exceed 1mm in case of and 2 mm in case of plywood of more than 5 ply and provided such gaps, if more than one, shall be spaces not less than 80mm away from each other and are staggered not less than 50mm away as between ply, the next ply having the same grain direction.



PLANT STANDARD

ED 049 00 92

REV NO 08

Page 11 of 25

7.5 WORKMANSHIP AND FINISH:

The plywood boards shall be of uniform thickness.

The faces of plywood boards shall be reasonably smooth and face veneers shall be reasonably uniform thickness.

7.6 TESTS:

For testing any other mechanical property of general purpose plywood, Subject to agreement between the purchaser and the supplier, reference shall be made to the provisions of IS 1734 Part 1 and 20)

8.0 Details of Drawings / Figures attached:

- Fig- 1 : Packing of panel - Preparation
- Fig- 2 : Shookes preparation
- Fig- 3 : Marking Plate
- Fig- 4 : Packed panel with plywood and silveroak battens
- Fig- 5 : Detailed joining of pkg shookes with battens
- Fig- 6 : Lifting of packed case
- Fig- 7 : Mechanical Latching clamps
- Fig 8 & 9 : CLW Railway panel packing
- Fig 10 to 13: Packing of panels and spares packing cases.

Additional points to be taken care for:

Easy Spares (Initial and O & M) Traceability and Identification at units as well as at sites:

(Recommendations from Corporate Systems and IT)

S1 No	Activity
1	All initiatl and O & M Spares preferraby supplied on one lot to site and



PLANT STANDARD

ED 049 00 92

REV NO 08

Page 12 of 25

	progressive inventory till all spares are accumulated could be kept at units
2	Spares (Initial and O&M) should be supplied in separate boxes/containers and not mixed in main supply boxes.
3	i) Initial Spares box/container to be labelled as "Initial Spares" in Red. Ref Fig: 14 ii) O & M Spares box/container to be labelled as "O & M Spares" in Green. Ref Fig : 14
4	iii) Initial spares box to have red colour strip as per the diagram Ref: Fig: 14 iv) Majority of spares (initial and O & M) are for indoor storage at site v) O & M Spares box to have green colour strip as per diagram. Ref Fig: 14
5	vi) Spares (Initial and O & M) packing list kept inside the boxes and affixed securely outside the box to contain the following: a) Customer Name b) Project / Power Station Name c) Customer PO No and Date d) Quantity total and Dispatched e) Unit Work Order No f) All the above to be developed from Unit IT System.
6	vii) All the spares (Initial and O & M) items to have tags (WO NO, Item Customer Order No, Customer Item, Description)
7	viii) Supply of spares by vendor should also be instructed to follow the points 2,3,4,5 and 6 as mentioned above

Action By: Sites on arrival of Spares (Initial and O & M) receipt

1	Material utilized if any from initial spares and O & M spares, should have prior written approval of concerned MUs. Such MUs shall also confirm replacement dates which should be entered in the system for creation of repository.
---	---



PLANT STANDARD

ED 049 00 92

REV NO 08

Page 13 of 25

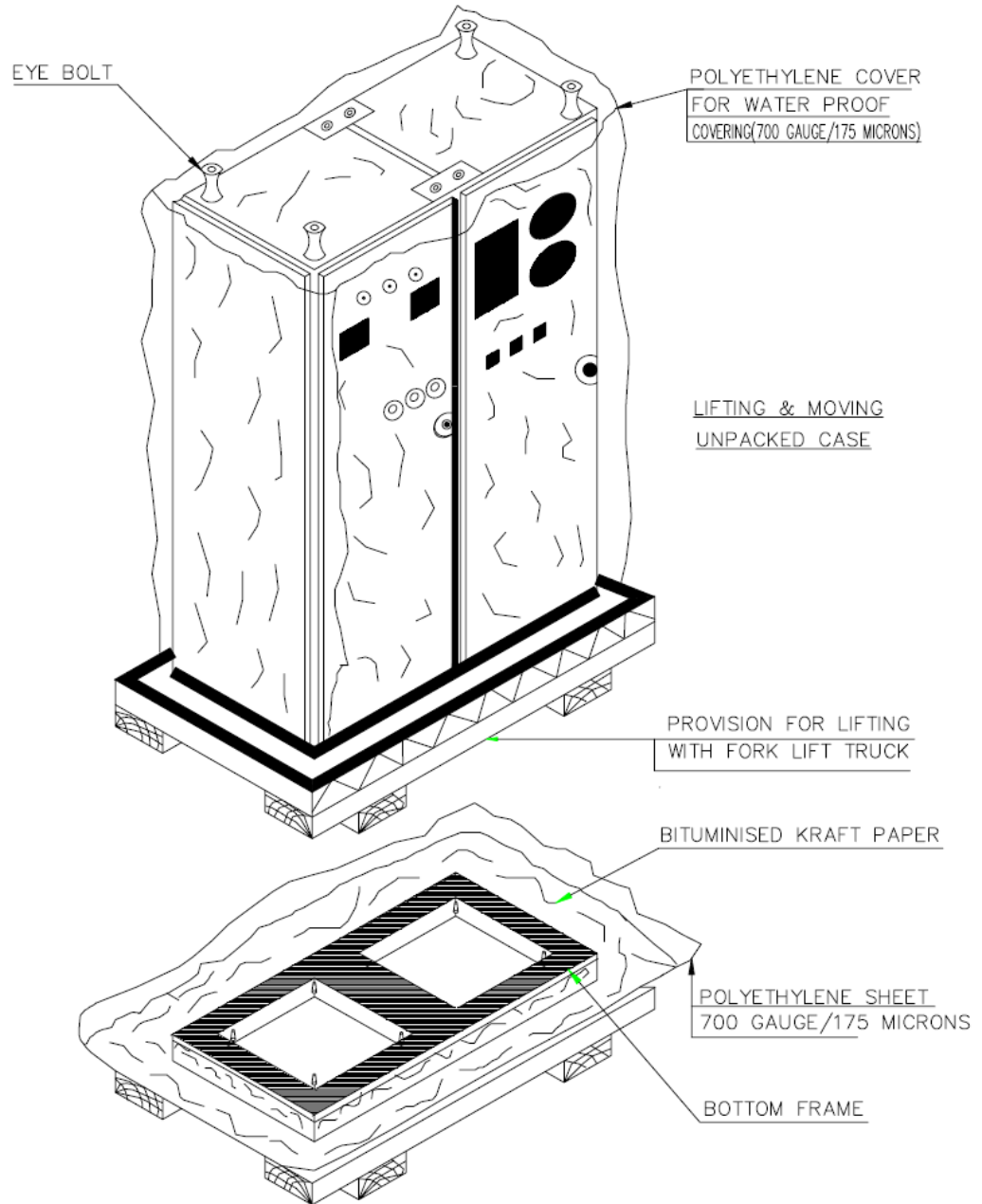

FIGURE-1



A4 - 14

PLANT STANDARD

ED 049 00 92

REV NO 08

Page 14 of 25

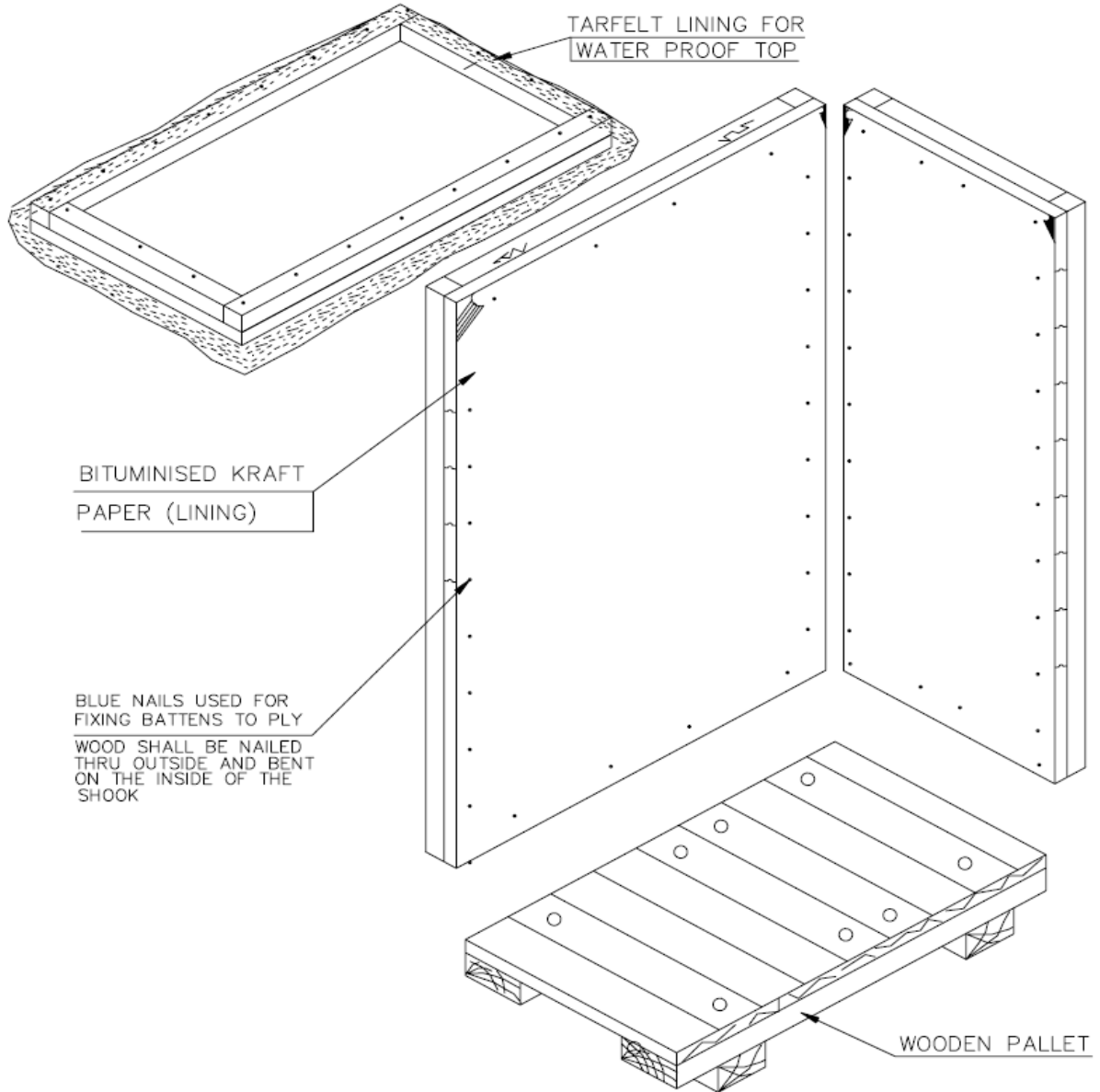

FIGURE-2



A4 - 14

PLANT STANDARD

ED 049 00 92

REV NO 08

Page 15 of 25

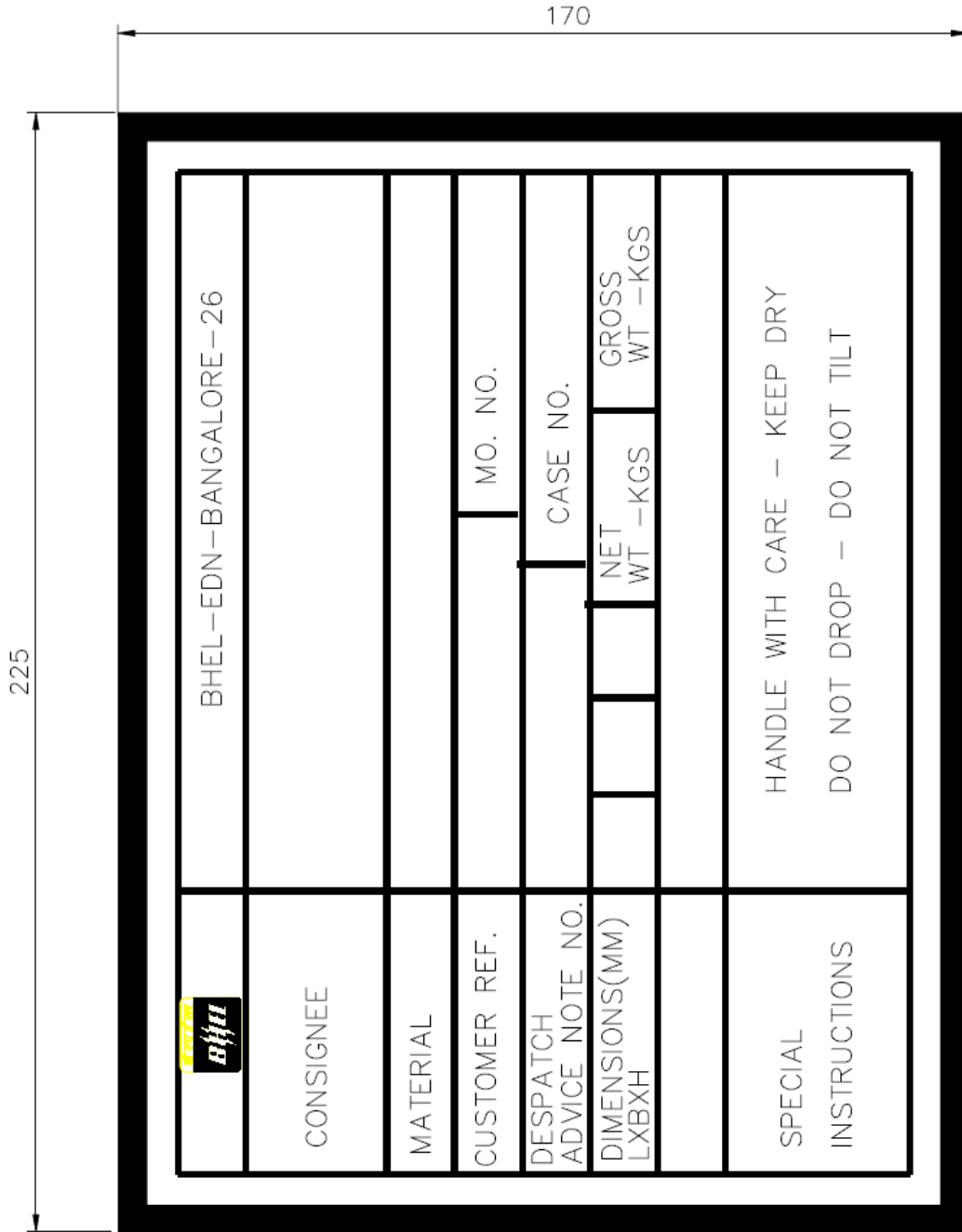

FIG-3 : MARKING PLATE



A4 - 14

PLANT STANDARD

ED 049 00 92

REV NO 08

Page 16 of 25

PLYWOOD SHOOKS BOLT TYPE WITH SILVER OAK BATTONS

FRONT VIEW

SIDE VIEW

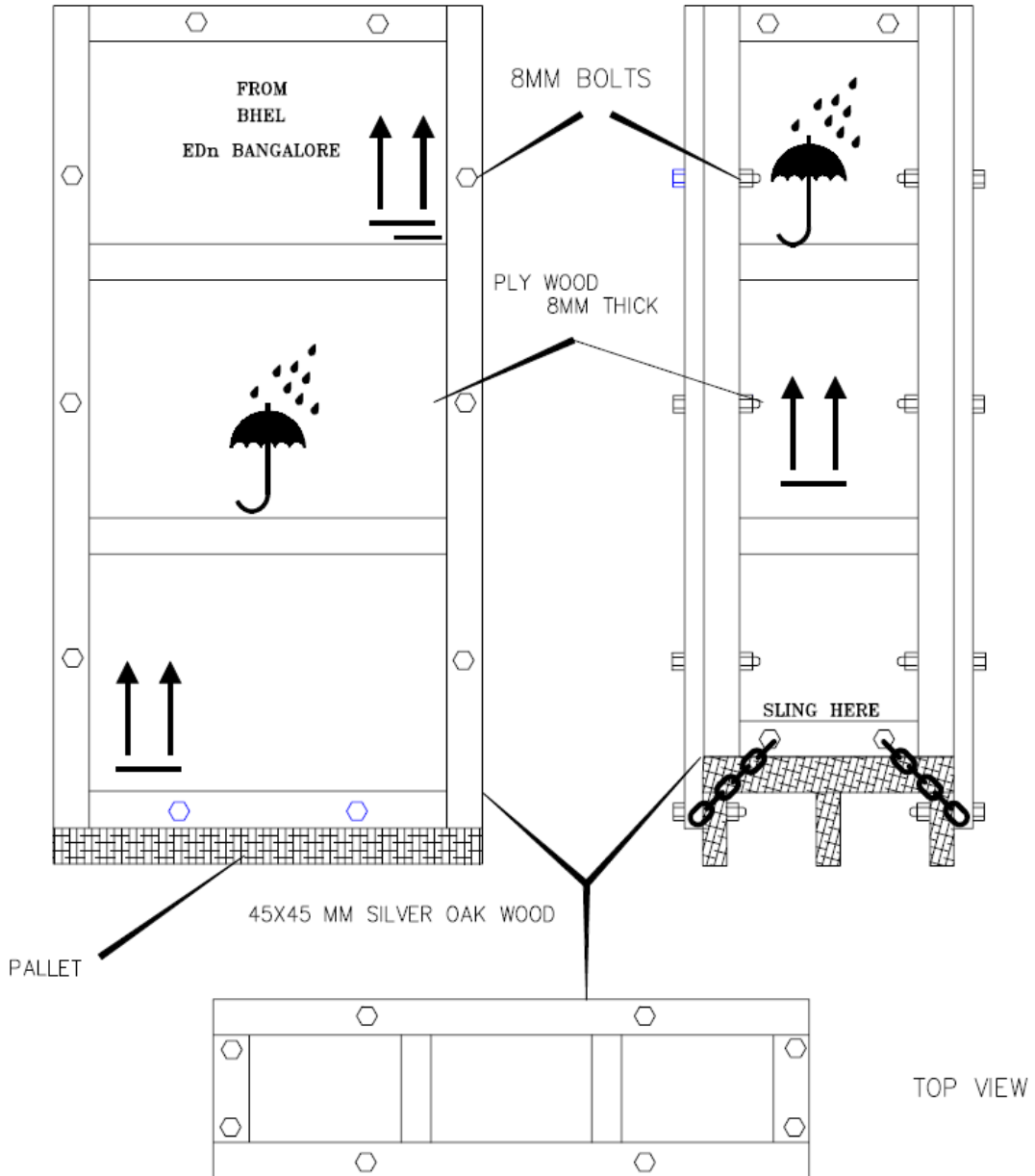

FIG-4



A4 - 14

PLANT STANDARD

ED 049 00 92

REV NO 08

Page 17 of 25

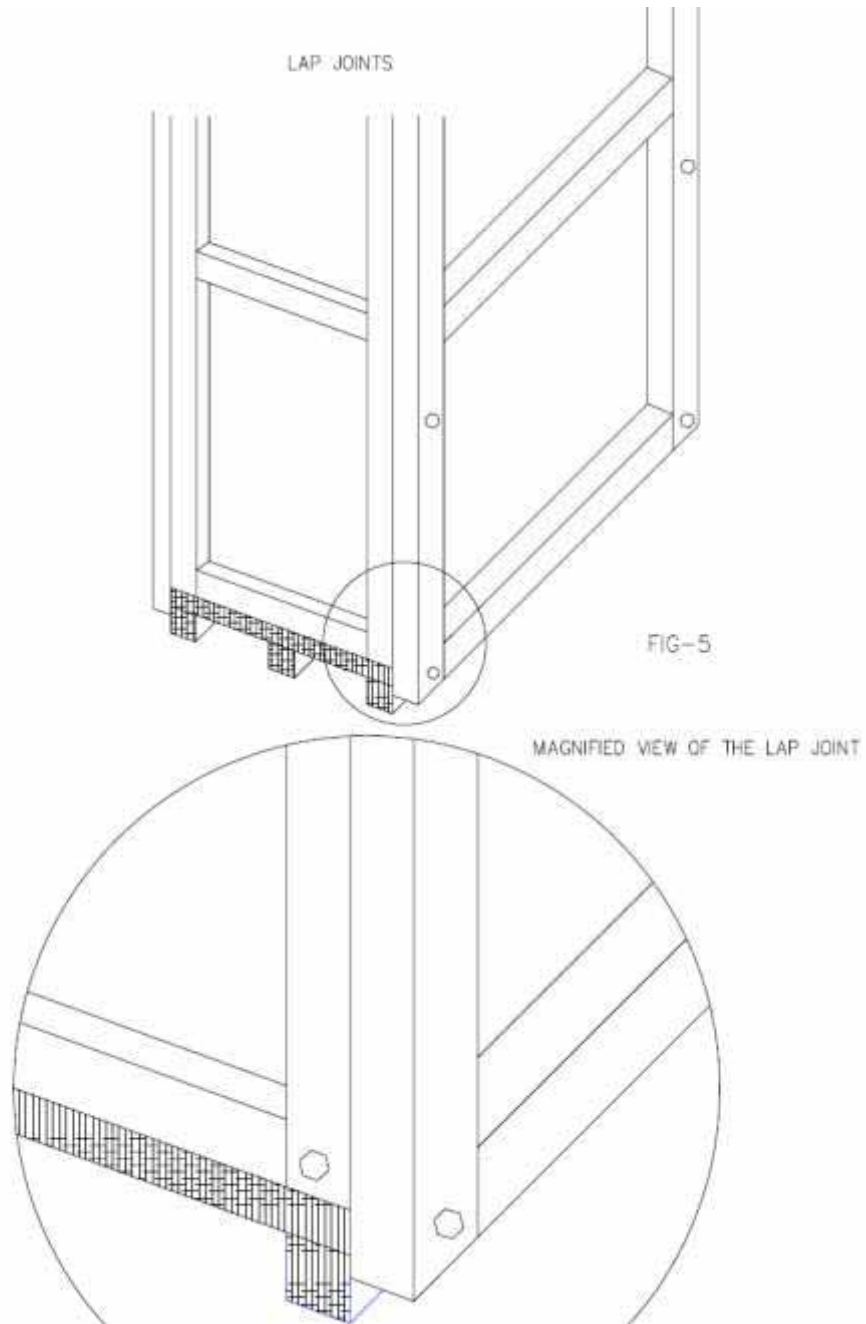

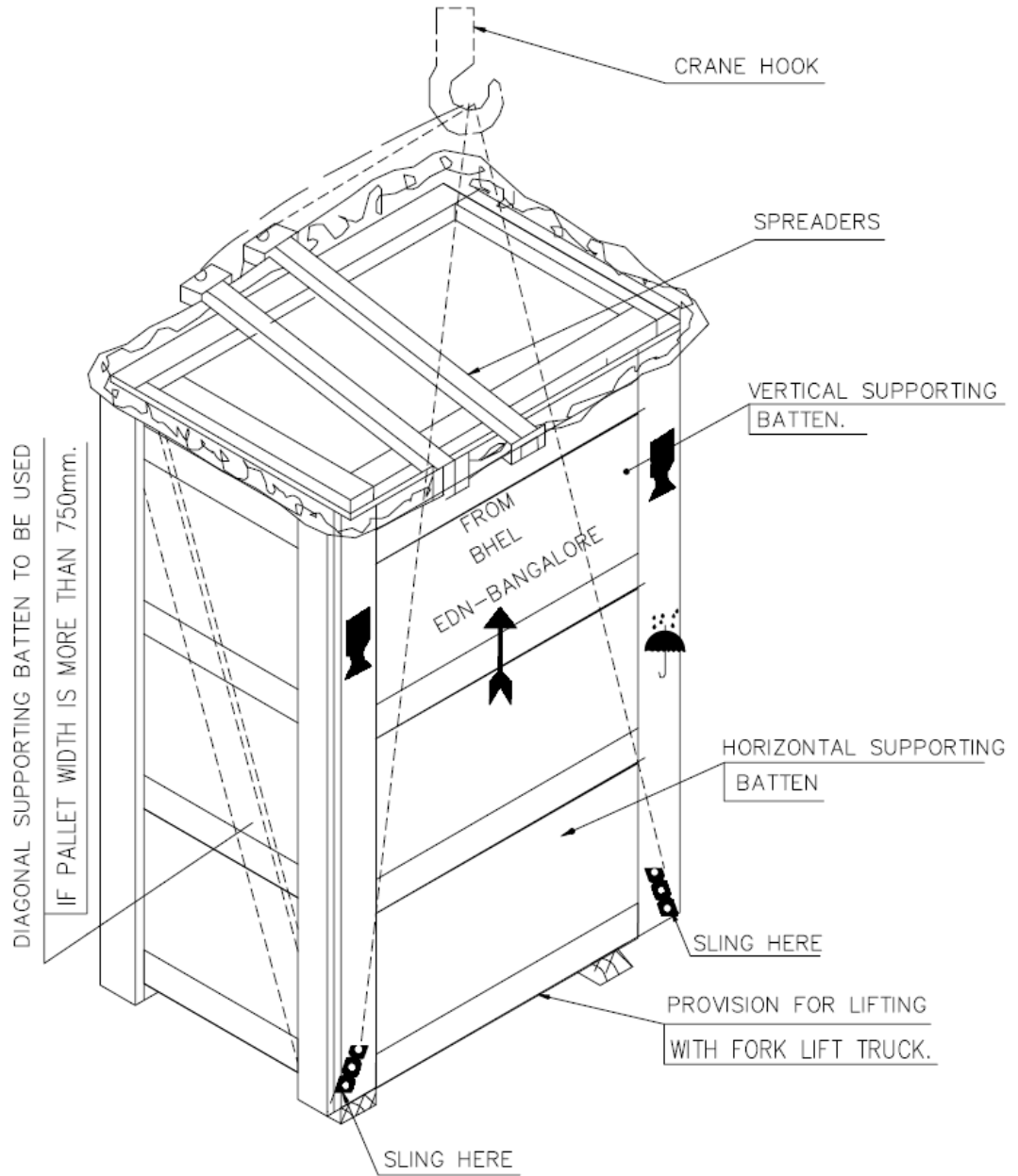

FIG-6 : LIFTING OF PACKED CASE



A4 - 14

PLANT STANDARD

ED 049 00 92

REV NO 08

Page 20 of 25

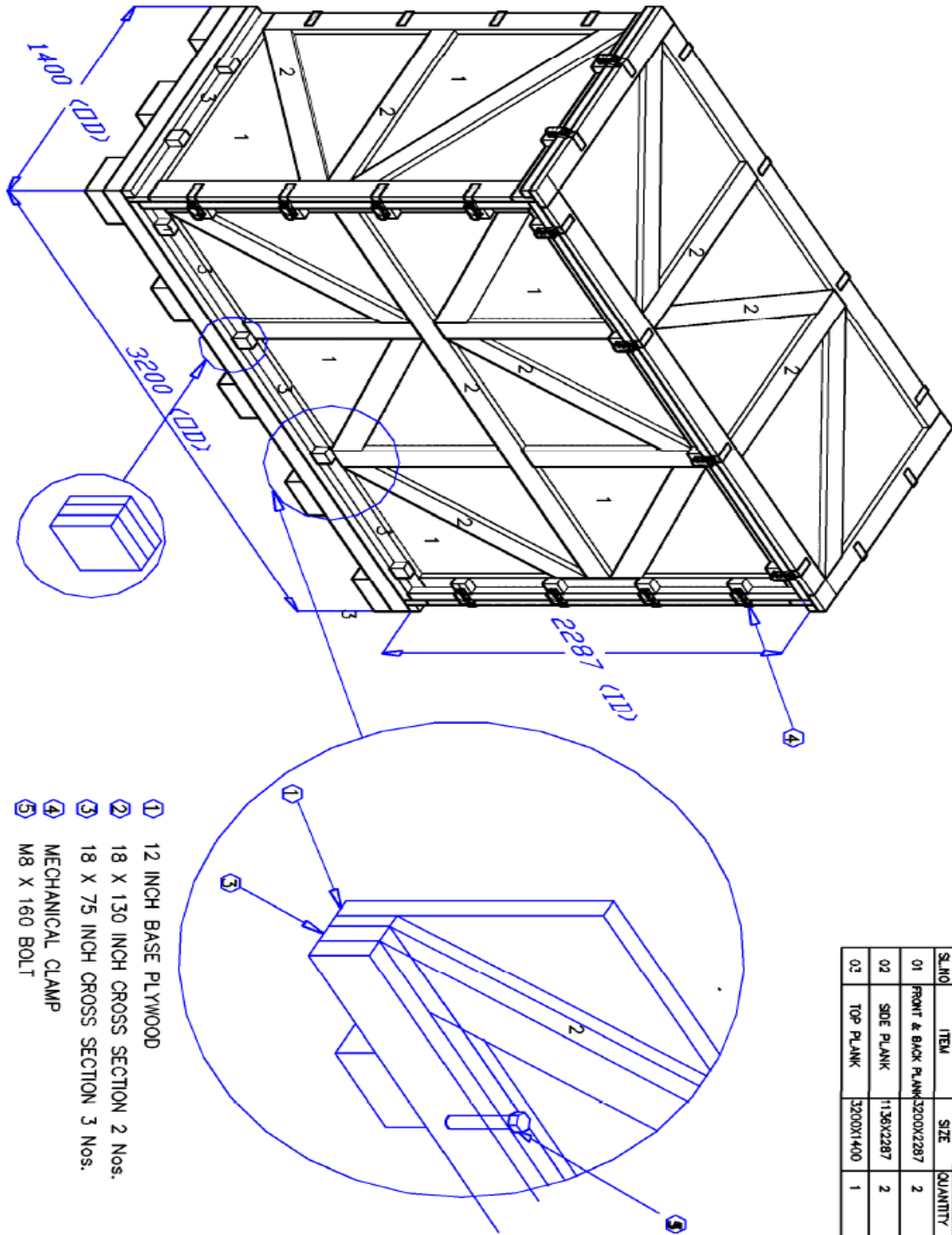

Fig - 8 : CLW Railway Panel Packing with Plywood & Plywood Support Battens



A4 - 14

PLANT STANDARD

ED 049 00 92

REV NO 08

Page 21 of 25

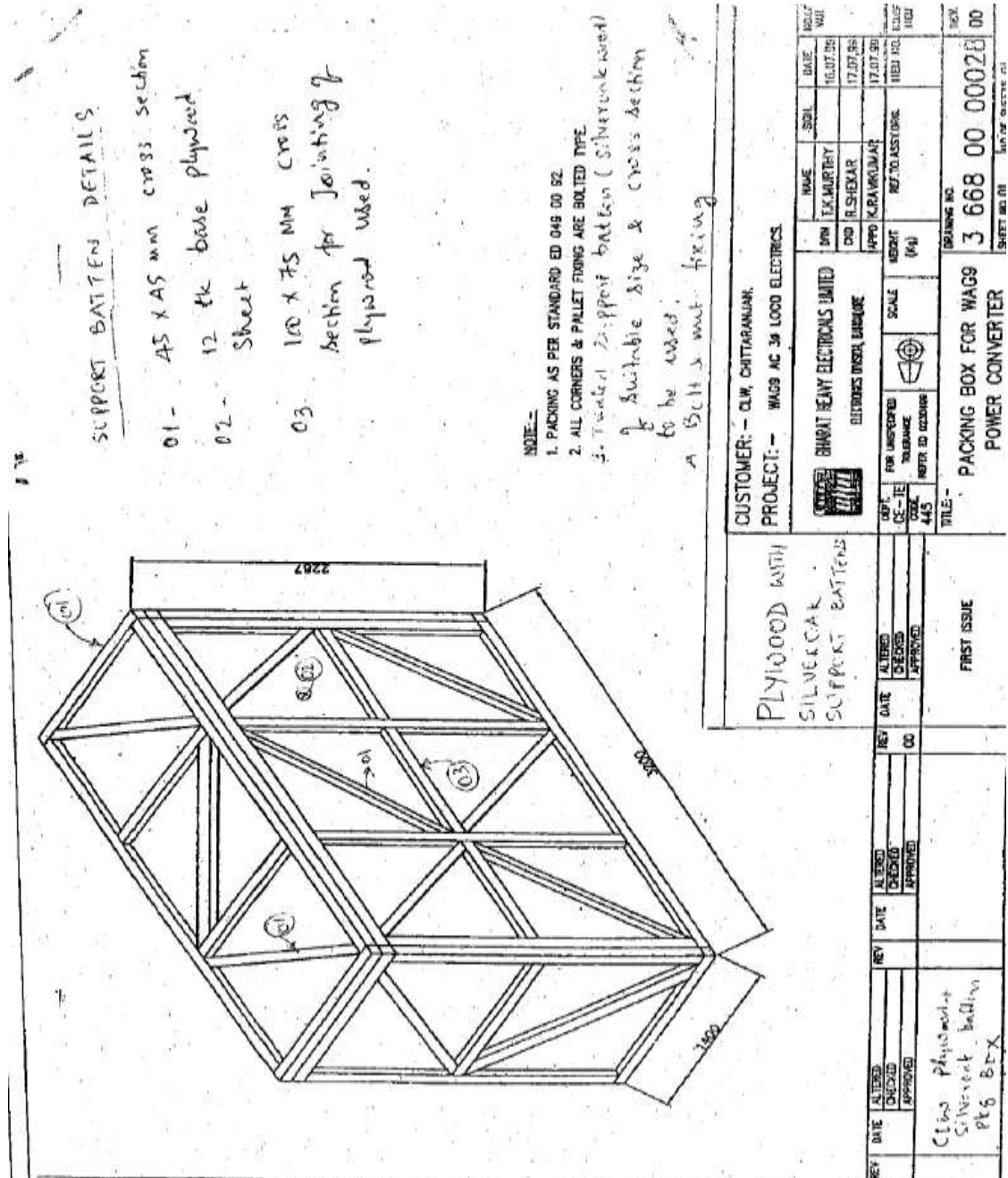

Fig - 9 : CLW Railways Panel Packing with Plywood & Silver Oak Battens



A4 - 14

PLANT STANDARD

ED 049 00 92

REV NO 08

Page 22 of 25

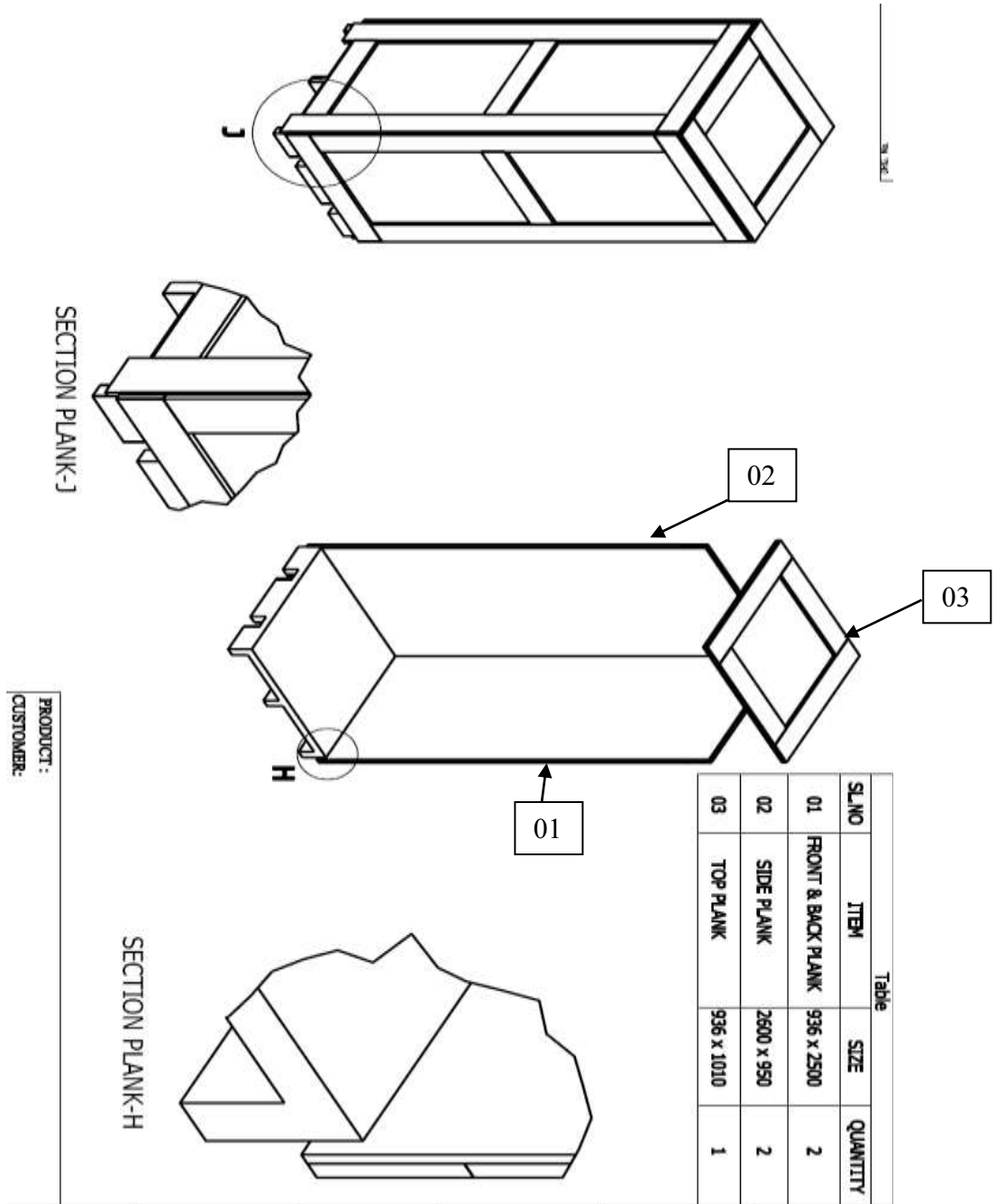

PRODUCT:
CUSTOMER:

Fig-10 : Plywood Packing for Single Suit Panel.



A4 - 14

PLANT STANDARD

ED 049 00 92

REV NO 08

Page 23 of 25

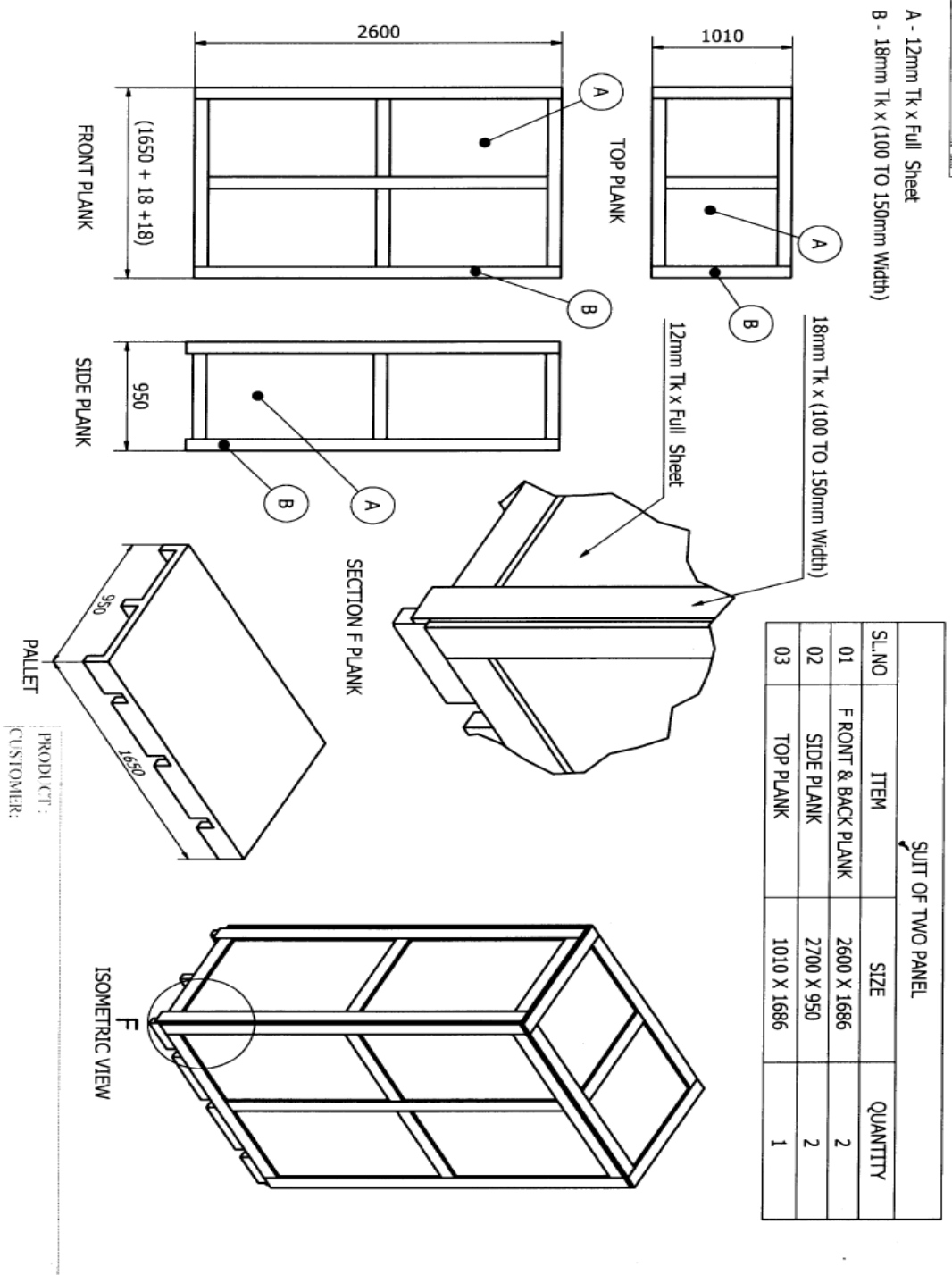

Fig - 11 : Plywood Packing for 2suit panel.



A4 - 14

PLANT STANDARD

ED 049 00 92

REV NO 08

Page 24 of 25

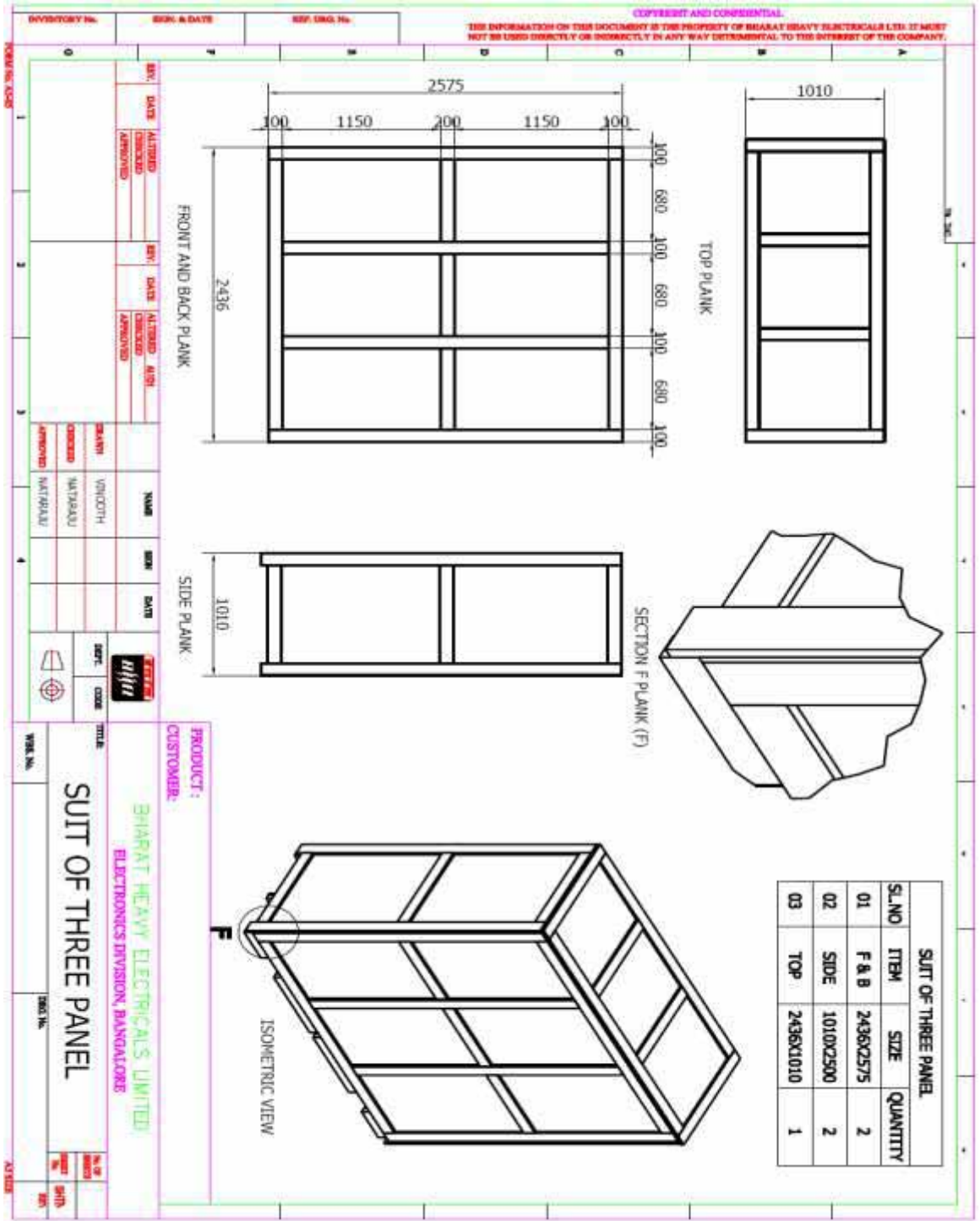

Fig – 12 : Three Suit Panel Packing



A4 - 14

PLANT STANDARD

ED 049 00 92

REV NO 08

Page 25 of 25

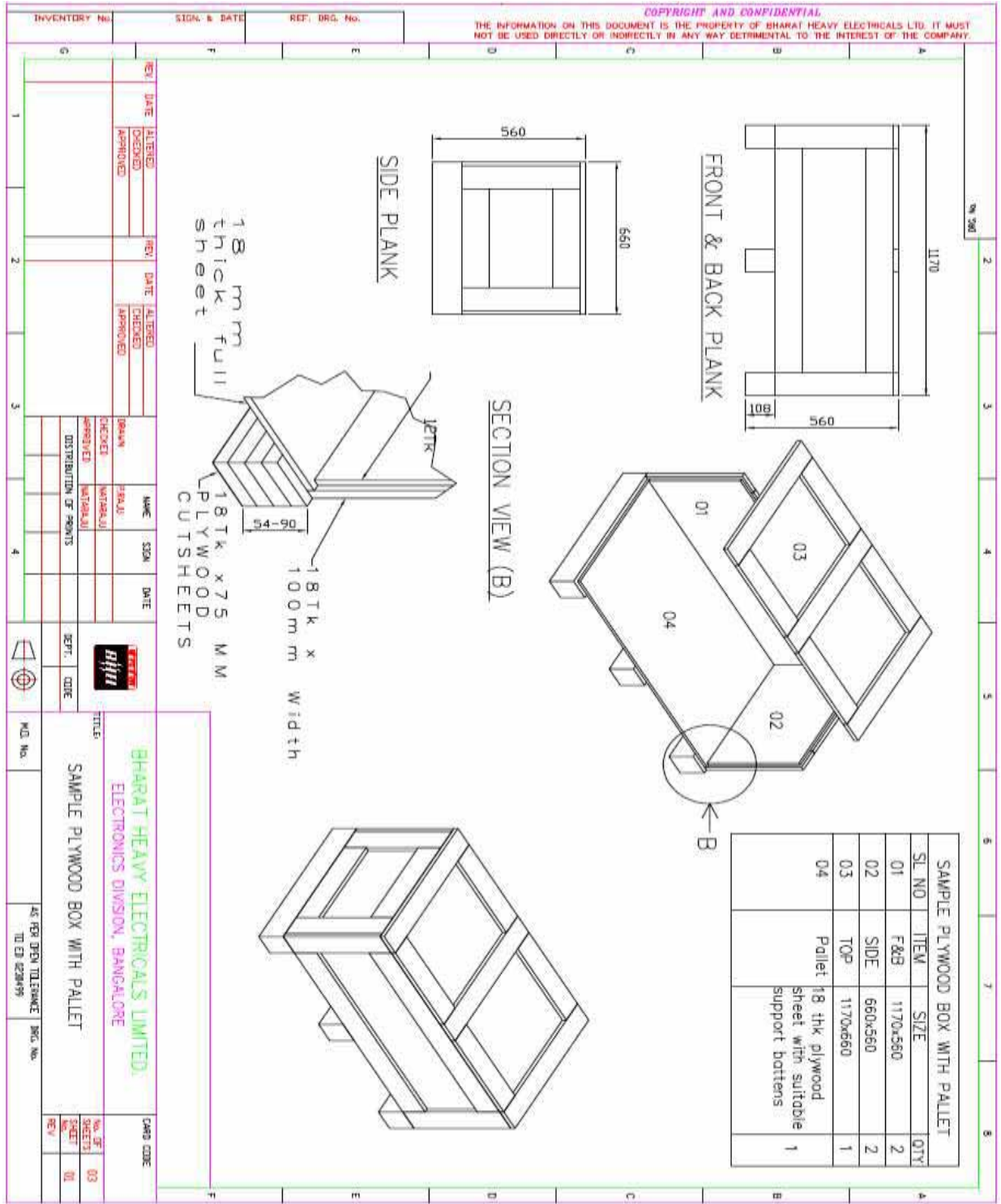

Fig – 13 : Plywood small case with Pallet



A4 - 15

PLANT STANDARD

ED 049 00 99

REV NO 13

PAGE 1 OF 27

REVISION HISTORY SHEET

REV NO.	DATE	NATURE OF CHANGE	REASONS	CHANGED BY	APPROVED BY
00	06/03/92	SUPERCEDES CN43000	-	VS MAS SHG	N.J
01	19/06/93	GENERAL	FEEDBACK FROM QUALITY	SHG	N.J
02	24/06/93	CL 3.4.10	FEEDBACK FROM QUALITY	SHG	N.J
03	01/07/93	SEMICONDUCTOR & PHOTOVOLTAIC PANELS ADDED	FEEDBACK FROM DESPATCH	SHG	N.J
04	17/10/94	TOTALLY REVISED	FEEDBACK FROM QUALITY	SHG	N.J
05	08/06/95	ANNEXURE ADDED	FEEDBACK FROM QUALITY & ACCEPTANCE CRITERIA OF WOOD ADDED	SHG	N.J
06	17/11/95	CL 2.5.10 ALTERED	FEEDBACK FROM QUALITY & SHIPPING	SHG	N.J
07	05/03/97	UNDER CL 3.0 & 3.9.1 RPP ADDED ACCEPTANCE CRITERIA REMOVED	FEEDBACK FROM SHIPPING & QC	SHG	N.S
08	29/08/2001	CL 2.2.8 & 4.1 CHANGED	FEEDBACK FROM SHIPPING & QC	SHG	NS
09	15.12.2009	INCLUSION OF PINE WOOD AND SOME CLAUSES HAVE AMENDED	FEEDBACK FROM SHIPPING	PGD / KPN	MSS
10	21.06.2013	Inclusion of recommendations pertaining to spares in page-11&28	Recommendations from Corporate systems & IT	HRN	MSS
11	11.01.2016	CL 2.5.5,2.5.6,2.5.11,2.5.12, 2.5.22 REVISED.	Feedback from shipping and after general review	HRN /EKP	BKD
12	06.03.2018	Clause 2.2.2 changed and 2.2.4 removed	Feedback from shipping	BKD	NV
13	06.06.2018	2.5.22 revised from mm to cm	Feedback from Shipping	BKD	Sathyanarayana

REV-13.

APPROVED: Sathyanarayana, AGM (T&PD)

PREPARED: BKD

ISSUED: STDS GROUP

DATE: 06/06/18



PLANT STANDARD

ED 049 00 99

REV NO 13

PAGE 2 OF 27

PROCEDURE FOR PACKING OF CONTROL EQUIPMENTS PRODUCTS USING RUBBER WOOD, SILVER OAK WOOD, PINE WOOD AND CARTONS

1.0 SCOPE: This standard covers the guidelines for packing of Control Equipments, semiconductor devices and Photo voltaic panels/cells.

2.0 MATERIALS:

2.1 WOOD:

2.1.1 **INLAND:** The wood shall be Rubber wood (*Havea Brasiliensis*) for packing of cubicles, loose items, spares and photovoltaic items meant for customers in India.

2.1.2 **EXPORT:** Silver Oak (*Grevillea Robusta*) / Pine wood shall be used for packing of cubicles and loose items meant for export.

2.2 DIMENSIONS:

2.2.1 Thickness of planks for Front, rear, top and bottom sides and binding, jointing battens shall be 25 +2/-3 mm.

2.2.2 Width of all planks including the tongue shall be more than 125 mm and after planning it shall be minimum 100 mm.

2.2.3 Minimum number of planks shall be used for a shook.

2.2.4 Horizontal, vertical, diagonal planks shall be given for binding (number of such planks depend on the dimension of panel, as given in Figure-2).

2.2.5 External sides of front and rear planks to be planed to facilitate writing of address and other markings.

2.2.6 Width of binding planks shall be minimum 100 mm.

2.2.7 Distance between any 2 binding planks shall be less than 750 mm. As shown in Fig-3, diagonal planks shall be used in between vertical binding planks when distance between inner to inner of vertical planks is more than 750 mm

2.2.8 Distance of the outer edges of these planks from the edge of case shall be less than 250 mm.

2.2.9 Diagonal planks are not required for top planks and width side also, if the width of pallet is less than 750 mm.

2.2.10 **Jointing of planks:** Single length planks shall be used for cubicles whose overall length is



PLANT STANDARD

ED 049 00 99

REV NO 13

PAGE 3 OF 27

less than 2400 mm. For cubicles of length more than 2400 mm, jointing is permitted. The jointing shall be done with one single or maximum of 2 planks of wood same as other planks of width 250 mm (minimum) with two rows of nails on either side of the joint in zigzag manner. From the joint along height side it shall be of lap joint with over lap of at least the width of plank.

2.2.11 Tongue and Groove joints: Two Consecutive planks shall be joined by tongue and groove joint. Depth of tongue shall be 12 ± 1 mm, thickness of tongue shall be 8 ± 1 mm. The groove dimensions shall be such that the tongue fits tightly into the groove to make a good joint.

2.3 PERMISSIBLE DEFECTS: - Wood shall be free from knots, bows, visible sign of infection and any kind of decay caused by insects, fungus, etc.

End splits: Longest end splits at each end shall be measured and lengths added together. The added length shall not exceed 60 mm per meter run of shook's. Wood pins shall be used to prevent further development of split.

Surface cracks: Surface cracks with a maximum depth of 3 mm are permissible. A continuous crack of any depth all along the length is not allowed.

2.4 .0 CHEMICAL TREATMENTS FOR PRESERVATION OF WOOD:-

2.4.1 This treatment provides protection to the packing wood against deterioration due to fungi and attack by termites, borers and marine organism and any kind of infections.

2.4.2 The wooden planks, after making tongues / grooves shall be treated with chemicals. For pine wood, treatment with ASCU/ CCA solution need not be done.

2.4.3 The chemical used shall be ready mix ASCU paste. This consists of Arsenic pent oxide, copper sulphate sodium dichromate. This Paste shall be mixed at the rate of 1 kg of paste per 10 liters of water to the extent of water used. Alternate this CCA paste as mentioned at Para 2.4.5 can also be used.

2.4.4 The chemical treatment shall be done at the premises of the contractor. A cement concrete tank of capacity to hold a minimum of 2000 liters of solution shall be constructed. The solution shall be prepared in the presence of BHEL- EDN's Representative by contractor. The wooden planks shall be soaked in the solution for a minimum of 12 hours. The solution shall be replenished after treating a maximum of 12 cubic meters of wood. A log book shall be maintained by the contractor to give the details of date of preparation of solution, quantity of solution prepared, quantity of chemicals used, Quantity of wood treated and the details of replenishment. Samples of solutions before mixing will be got tested at the laboratories designated by BHEL. The testing fees to be paid to the laboratories will have to be borne by the contractor. The paste shall be tested as and when required.



PLANT STANDARD

ED 049 00 99

REV NO 13

PAGE 4 OF 27

2.4.5 Specifications for water soluble type wood preservatives: Copper – Chromium – Arsenic [CCA]:

Copper – Chromium – Arsenic preservative formulation shall be as per IS : 10013 Part – II – 1981 shall consist of following active ingredients in nominal proportions by weight as shown below:

Arsenic Pent oxide	$AS_2O_5 \cdot 2H_2O$	12.5
Copper Sulphate	$CuSO_4 \cdot 5H_2O$	37.5
Sodium Dichromate	$Na_2Cr_2O_7 \cdot 5H_2O$	50.0
Or		
Potassium Dichromate	$K_2Cr_2O_7$	

2.5 OTHER MATERIALS:

2.5.1 NAILS: The dia. of the nails shall be 3.15 mm. The length of the nails shall be 65 mm wherever two planks of 25 mm thickness are joined and 75 mm wherever a 25 mm plank is joined to a 50 mm plank.

2.5.2 BLUE NAILS: These are used for nailing bituminized Kraft paper/hessian cloth to the planks. The length of the nails shall be 16 mm.

2.5.3 HOOP IRON STRIPS: These are used for strapping the boxes. The width of the strips shall be 19 ± 1 mm and thickness 0.6 ± 0.01 mm. The material shall be free from rust.

2.5.4 CLIPS: These shall be used for strapping the hoop iron strips on the boxes.

2.5.5 BRACKETS: These brackets are used for nailing to the corners of cubicle boxes. The brackets shall be of mild steel of thickness min 2 mm and width 25 ± 1 mm. The brackets shall be of "L" shape, the length of each side being 100 ± 2 mm. Two holes shall be provided towards the end of each side for screwing /nailing.

2.5.6 FASTENERS: Bolts, double nuts, spring washers will have to be used for packing of some special items like transformers, reactors, breakers, etc., to hold the job to the bottom plank of the box. The bolts, nuts, washers will be provided by the vendor. Drilling of holes will have to be done using contractor's tools.

2.5.7 POLYETHYLENE SHEET: The polyethylene sheets are used to make covers to the jobs individually. The material shall have a thickness of 0.175 mm (175 microns). The polyethylene sheet shall be clear and transparent.



PLANT STANDARD

ED 049 00 99

REV NO 13

PAGE 5 OF 27

- 2.5.8 BITUMINISED WATER PROOF KRAFT PAPER: This is used for lining the inside of shoots of cubicles.
- 2.5.9 BITUMEN COATED HESSIAN POLYETHYLENE KRAFT PAPER: This is used for lining the inside of top planks of cubicles and for lining of all inner sides of boxes.
- 2.5.10 RUBBERISED COIR: The rubberized coir is used as cushioning material .For the packing of loose items, items are to be arrested by using rubberized coir. For the packing of cubicles rubberized coir of thickness 25mm and width 75mm shall be used.
- 2.5.11 FOAM RUBBER / 'U' FOAM: This is used for covering the delicate items. This material is provided by the vendor.
- 2.5.12 THERMOCOL (EXPANDED POLYSTYERENE) SHEETS): This is used for covering delicate items. This material shall be provided by the vendor.
- 2.5.13 MARKING PLATE: This shall be of anodized aluminum sheet. Details and specifications are given in Fig-5.
- 2.5.14 PACKING SLIP HOLDER: This shall be of galvanized iron /tinned
- 2.5.15 SILICA GEL: This shall be of indicating type.
- 2.5.16 COTTON BAGS: These are used for holding silica gel. The bags shall have the following matter indicated them:
- BHEL-EDN, BANGALORE - 5 60 026
SILICA GEL INDICATING TYPE
BLUE : ACTIVE
ROSE : REDUCED ACTIVITY
WHITE : NO ACTIVITY. TO BE REPLACED WITH FRESH SILICA GEL

- 2.5.17 COTTON/ PLASTIC TAPE: This is used for tying small items .And also to prevent vibrations of moving parts within the cubicles.
- 2.5.18 MARKING INK: The ink used normally is black in color. In some special cases other color also will have to be used. The ink shall be non-fading/indelible and non-washable by water.
- 2.5.19 POLYETHYLENE BAGS: These are to be used for keeping the, Packing slips. The bag shall be of size 70 mm X 100 mm (minimum).
- 2.5.20 Hessian cloth, twine thread, paint will have to be used in packing certain items.



PLANT STANDARD

ED 049 00 99

REV NO 13

PAGE 6 OF 27

2.5.21 Mechanical Latching clamps: For CLW Railway panels and similar Panels self locking clamps can also be used on need basis in conjunction with or apart from regular bolt and nut fixing arrangement. [Refer Drawing Fig-7]. For reusable boxes, these clamps provide easy locking and unlocking arrangement. These clamps will be made available from BHEL in some cases.

2.5.22 STICKERS The following stickers to be put by the vendor on cubicles/Boxes after packing.
1. Case No sticker : 2 nos. Size 25 cm X 4.5 cm 2. BHEL Monogram sticker : 1 no . Size 17.5 cm X 23 cm 3. Address sticker : 2 nos. Size 38 cm X 30 cm 4. Direction sticker " Front " & " Back " - 4 nos .Size 20 cm X 7.5 cm 5. Chain Mark Sticker : 4 Nos. Size - 30 cm X 7.5 cm 6. "Fragile " sticker : 2 Nos Size. 21cm X 15 cm 7. "DO NOT STACK " sticker - 2 Nos. Size 30 cm 22 cm

3.0 PACKING SPECIFICATIONS: Different types of packing are used as follows:

- 1) Packing of cubicles with rubber wood.
- 2) Packing of cubicles with Silver Oak wood / Pine wood
- 3) Packing of empty cubicles with rubber wood.
- 4) Packing of loose items/spares with rubber wood.
- 5) Packing of loose items /spares with Silver Oak wood.
- 6) Packing of Photo-voltaic items with rubber wood.
- 7) Packing using bitumen coated hessian polyethylene Kraft papers.
- 8) Supply of rubber wood pallets for empty cubicles.
- 9) Packing of semiconductor panels.
- 10) Packing of material covered under category of RPP (Registered Postal Parcel)
- 11] Packing of materials using PVC [sunspace] / corrugated Kraft paper cartons.
- 12] Packing of materials using heavy duty cartons

3.1 PACKING OF CUBICLES WITH RUBBER WOOD:

3.1.1 The packing is to be done as per clause 2.0 in all respects.

3.1.2 The cubicles are already fixed on wooden pallets. Hence the contractor need not arrange the bottom pallets normally.

3.1.3 The cubicles will be of different sizes both widthwise and lengthwise. The cubicles may be made up of single suite, 2 Suite, 3 Suite, 4 Suite, etc., The width of the cubicles generally varies from 400 mm to 1650mm. The length of the cubicle, generally varies from 1500 mm to 4800 mm. The height is normally 2430 mm. In some cases the height may be less/more.

3.1.4 **BITUMINISED WATER PROOF KRAFT PAPER:** The inner surface of 4 sides of shoo's shall be nailed with Bituminized water proof Kraft paper (as per 2.5.8) using blue nails (as per 2.5.2) wherever 2 pieces of Kraft paper are used, the joint shall have an overlap of minimum 20 mm.



PLANT STANDARD

ED 049 00 99

REV NO 13

PAGE 7 OF 27

3.1.5 BITUMEN COATED HESSIAN POLYETHYLENE KRAFT PAPER: The inner surface of top cover shall be nailed with Bitumen coated Hessian polyethylene Kraft paper (as in 2.5.9). This sheet shall project outside on 4 sides by at least 100 mm and shall be nailed properly on sides. Joining of sheets should have overlap of minimum 20 mm.

3.1.6 POLYETHYLENE SHEET COVERING: The cubicles shall be covered with a polyethylene petticoat (Polyethylene sheet as per 2.5.7). This shall be 'tailor made' to fit the cubicle. The sealing shall be such as not to allow any moisture to enter the cubicle.

3.1.7 SILICA GEL: Silica gel (as per 2.5.15) packed in cotton bags shall be kept at different places inside the cubicle as per EDN directions. Each suit of cubicle shall be provided with 1 kg of Silica gel (for a 4 suit cubicle 4 kgs of Silica Gel to be used. The bag containing silica gel to be as per 2.5.16).

3.1.8 LOOSE PARTS: Any loose parts in the cubicles shall be tied using cotton/ plastic tape. Wooden battens shall be provided wherever necessary.

3.1.9 WOODEN BATTENS: In case of cubicle which are not rectangular in shape like control desks, sufficient number of wooden rafters/battens of proper size shall be provided to give strength to the package.

3.1.10 RUBBERISED COIR: Gap between the cubicle and the case shall be filled with rubberized coir (as per 2.5.10) with distance between consecutive layers less than 500 mm.

3.1.11 CLAMPING: Packing shall be bound at edges by nailing M.S.clamps / Brackets (as per 2.5.5). Each vertical edge shall have minimum 3 clamps. Top horizontal edges will have one clamp for every meter length of package. However, minimum 4 clamps shall be nailed at the top for any cubicle.

3.1.12 PACKING SLIP: Packing slip kept in the polyethylene bag (As per 2.5.19) shall be placed in the box at appropriate place. In addition, one more packing slip covered in polyethylene cover and packing slip holder (as per 2.5.14) shall be nailed to front / rear of case.

3.1.13 MARKING PLATE: One no. (As per 2.5.13) shall be nailed to the front side of the case.

3.1.14 CASE MOUNTING: After complete packing, stencil marking of various details and marking of symbols shall be done as per BHEL instructions using indelible / non washable marking ink.

3.2 PACKING OF CUBICLES WITH SILVER OAK / PINE WOOD: Packing of cubicles for export shall be done exactly in same manner as described at 3.1 except for the following changes: -

- Wood shall be Silver oak/ Pine wood instead of rubber wood.
- Double polyethylene petticoat instead of one.
- Fumigation may have to be done if required (BHEL Scope).



PLANT STANDARD

ED 049 00 99

REV NO 13

PAGE 8 OF 27

3.3 Different types of Cubicles with sizes for Packing

SL TYPE OF CUBICLE VARIANT DIMENSIONS [Internal sizes]

01 Single suite cubicle	- 900 x 950 x2500
02 Two suite cubicle	- 1650 x 950 x 2500
03. Three suite cubicle	- 2400 x 950 x2500
04. Four suite cubicle	- 3150 x 950 x 2500
05. Regulation cub	- 1300 x 1350 x 2500
06. Thy cub	- 2870 x 1350 x 2500
07. VFD Cub	- 3800 x 1550 x 2500

3.4 PACKING OF LOOSE ITEMS/SPARES USING RUBBER WOOD:

3.4.1 Shape of cases shall be square, rectangular with single gabled roof or with double gabled roof depending on the nature of the job to be packed. Construction shall be as per drawings enclosed. Only gable will be additional as required.

3.4.2 Wood shall be rubber wood with Tongue and Groove joint as per clause 2.2.12.

3.4.3 Chemical treatment as per clause 2.4 to be done.

3.4.4 Width of planks shall be at least 100 mm. Width of binding planks (battens) shall be at least 75mm.

3.4.5 External surface of planks on front and rear shall planed 100% (except bottom plank).

3.4.6 Inner surfaces of all 6 sides shall be lined with bitumen coated hessian polyethylene Kraft paper (as per clause 2.5.9) using blue nails.

3.4.7 Rubberized coir of minimum 25mm thickness and 100 mm width shall be nailed to inner surfaces of bottom and 4 sides of box.

3.4.8 Internal packing: Items that go into the box shall be packed using polyethylene sheet/ U foam/ thermocol sheets/ air bubbled sheets/ paper cartoons and cotton tape. Any space left. Between the job and the sides and the top of the box shall be filled with rubberized coir to get proper cushioning effect.

3.4.9 Certain items like transformers, reactors, breakers, etc., shall be bolted to the bottom of the box using bolts, nuts and washers.

3.4.10 Silica gel as per clause 2.5.15 held in cotton bags as per clause 2.5.16 shall be kept at proper places in the box.



PLANT STANDARD

ED 049 00 99

REV NO 13

PAGE 9 OF 27

SL NO	BOX INNER DIMENSIONS (mm)	VOLUME (liters)	QUANTITY OF SILICA GEL (grams)
1	300X300X300	27	100
2	400X400X400	64	100
3	500X500X400	100	100
4	600X600X400	144	100
5	700X700X400	196	100
6	770X770X500	297	100

3.4.11. Packing slip kept in polyethylene bag (clause 2.5.19) shall be placed in the box.

3.4.12. Marking plate as per clause 2.5.13 shall be nailed to side of the box.

3.4.13. Two numbers of hoop iron strips as per clause 2.5.3 shall be strapped tightly on the case using clips.

3.4.14. Stencil marking of various details and marking of various symbols shall be done as per BHEL instructions using indelible/non-washable marking ink.

3.4.15 Loose items to be kept inside the cubicle

- The components which are removed from cubicle for shipping purpose only, such as meters shall be kept inside the cubicle individually kept in wooden box and tied firmly in bottom of Cubicle.
- Other items which are given loose in addition to cubicle shall be packed in separate boxes (like cables).
- For transformer cubicles loose items shall be packed in separate boxes and these boxes may be tied firmly in bottom of cubicles.
- Items which are bigger in size such as impulse tubes may be kept in top of cubicles firmly bunched and tied.

3.5. PACKING OF LOOSE ITEMS USING SILVER OAK / PINE WOOD: Packing of loose items for export shall be done in same manner as at clause.3.4 . except for the following changes:

- Wood shall be Silver oak/ Pine wood instead of rubber wood.
- Fumigation may have to be done.
- 2 polyethylene covers to be provided.



PLANT STANDARD

ED 049 00 99

REV NO 13

PAGE 10 OF 27

3.6 PACKING OF PHOTO VOLTAIC PANELS, ETC.USING RUBBER WOOD:

Same as 3.4 above except for the following changes:

- Wood need not be treated with chemical solution.
- Tongue and groove jointing is not required. But planks shall be so joined as to not leave any gap at the joint. Bituminized Kraft paper and Bituminized Kraft sheet need not be used.
- Silica gel need not be used.

3.7 PACKING USING BITUMEN COATED HESSIAN POLYETHYLENE KRAFT PAPER:

3.7.1. This method is adopted for packing of poles, frames, Empty boxes, etc.

3.7.2. Job shall be covered and stitched tightly with bitumen coated hessian polyethylene Kraft paper.

3.7.3. Marking has to be done as mentioned in CL 3.4.14.

3.8 SUPPLY OF RUBBER WOOD PALLETS FOR EMPTY CUBICLES:

3.8.1. The wood shall be rubber wood.

3.8.2. Thickness of planks shall be 25 ± 2 mm. The size of the supporting battens at bottom shall be 75 ± 2 mm (width) and 100 ± 2 mm (height).

3.8.3. If the width of the pallet is 1000 mm or less, only 2 supporting battens at the edges may be provided. In case of pallets having width of more than 1000 mm, one extra supporting batten shall be provided in the middle.

3.8.4. Jointing of top planks is not permitted for pallets of width less than 1000mm. For pallets of width more than 1000 mm, jointing of top plank is permitted. However, joint shall be at the center of the supporting batten.

3.8.5 The consecutive top planks shall be so nailed as to leave no gap. Tongue and groove joint is not required.

3.9 PACKING OF SEMICONDUCTOR DEVICES

Semiconductor devices shall be received in prepackaged condition as per the device type and packed in plywood boxes as per the following procedure,



PLANT STANDARD

ED 049 00 99

REV NO 13

PAGE 11 OF 27

- Provide thermocole sheets/rubberized coir.
- Stack the preplaced devices inside the case.
- Fill up gaps with thermocol sheets/rubberized coir.
- Close the top cover and nail.
- Provide suitable marking of the package details.

- 3.9.1 Packing of material for Registered Post Parcel (RPP) RPP packing boxes to be made in-house with 12mm (for sides) and 6mm thick (for top and bottom) commercial quality ply wood sheet. The size of the box should be decided on the material to be dispatched. Between material 10mm and 15mm thick thermocole sheets or rubberized coir/foam should be provided as cushion.
- 3.9.2. Packing of materials using sunpac cartons and corrugated Kraft paper cartons: Individual items can be packed using sunpac or polypropylene [PVC]/ corrugated Kraft paper cartons of suitable sizes and grammage depending upon the items to be packed. Heavy duty cartons can also be used for packing of loose items, manuals, repaired items and others.
- 3.9.3. Packing of materials using Heavy duty cartons: Panels can also be packed using Heavy duty carton with other required packing materials having 2000gsm corrugated board of 7 ply 15 thick. Loose items and spares can be packed using 5ply 2000gsm corrugated heavy board with other packing materials. Different sizes of cartons are required depending upon the sizes of the items being packed. Details are separately given.

4.0 ADDITIONAL POINTS TO BE FOLLOWED FOR EXPORT ORDER SEAWORTHY PACKING:

- 4.1 Packing to be done as per Fig - 6.
Thickness of G.I.sheet 0.3 mm. plus or minus 0.05 [0.3-0.05]

	PLANT STANDARD	ED 049 00 99 REV NO 13 PAGE 12 OF 27
---	-----------------------	--

Additional points to be taken care for :

Easy spares [Initial and O&M] Traceability and Identification at units and as well as at sites:

(Recommendations from Corporate Systems & IT)

Sl	Activity
1	All Initial and O&M spares preferably supplied in one lot to site and progressive inventory till all spares are accumulated could be kept at units.
2	Spares (Initial and O&M) should be supplied in separate Boxes / Containers and not mixed in main supply boxes.
3	i) Initial spares Box / Container to be labeled as "INITIAL SPARES " in RED. Ref fig: 14 (Page-26). ii) O & M spares Box /Container to be labeled as" O&M SPARES " in GREEN. Ref fig: 14 (Page-26).
4	iii) Initial Spares Box to have red Color strip as per diagram. Ref fig: 14 (Page-26). iv) Majority of spares (initial and O&M) are for indoor storage at site. v) O&M spares box to have green Color strip as per diagram. Ref fig: 14 (Page-26).
5	vi) Spares (Initial and O&M) Packing list kept inside the boxes and affixed securely outside the box to contain vii) Custom name viii) Project / Power station Name ix) Customer PO No and date x) Sl no of customer PO. xi) Quantity total & dispatched. xii) Unit work order number xiii) All above to be developed from Unit IT System
6	xiv) All spares (Initial and O&M) items to have tags (wono, item customer order no, customer item.description)
7	xv) Supply of spares by Vendor should also be instructed for following point 2,3,4,5,6 mentioned above.

Action By : Sites on arrival of spares (Initial and O&M)Receipt .

	Activity
1	Material utilized if any from Initial and O&M spares , should have prior written approval of concerned MUs. Such MUs shall also confirm replacement dates which should be entered in the system for creation of repository.



5.0 DETAILS OF DRAWINGS/FIGURES ENCLOSED

FIG-1: Details Of Cubicle Packing Box

FIG-2: Binding Of Panel

FIG-3: Lifting Of Packed Case

NOTE: 1) Spreaders are to be used only for lifting the case.

2) Spreaders are wooden items & not nailed to the case.

3) Height between crane hook & spreaders to be kept Minimum to void rotation of case while lifting.

FIG-4: Lifting And Moving Un Packed Case

FIG-5: Marking Plate

FIG-6: Closed Packing Case With G.I. Sheet Showing Layers Of Packing Materials.

FIG-7: Mechanical Latching Clamp

FIG-8 to 15 : Sample Packing drawing of single/ double / triple & four suit panel

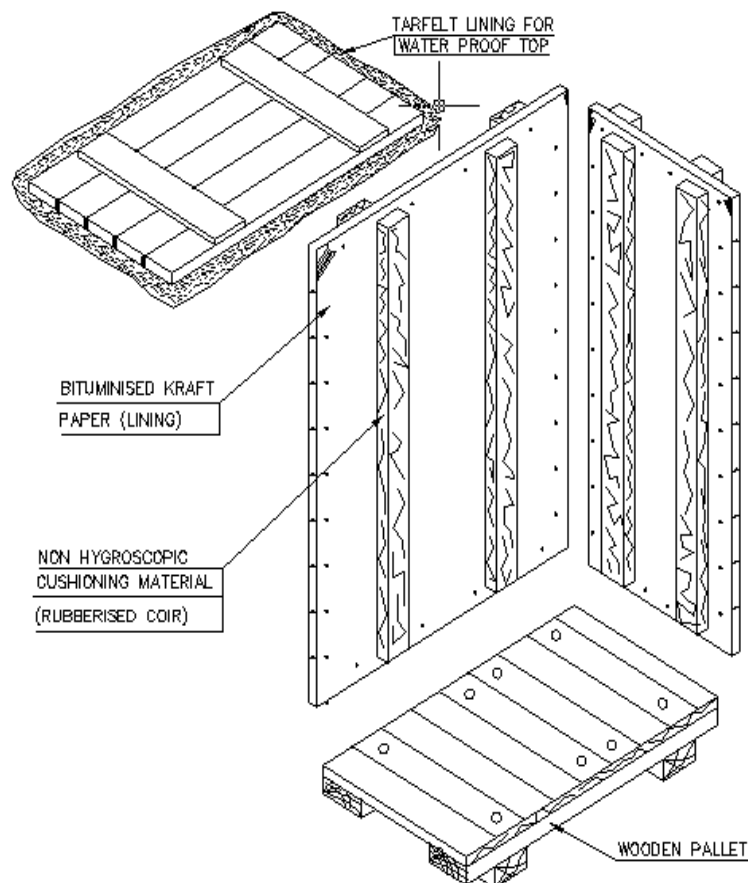



Fig. 2 : Binding of Panel

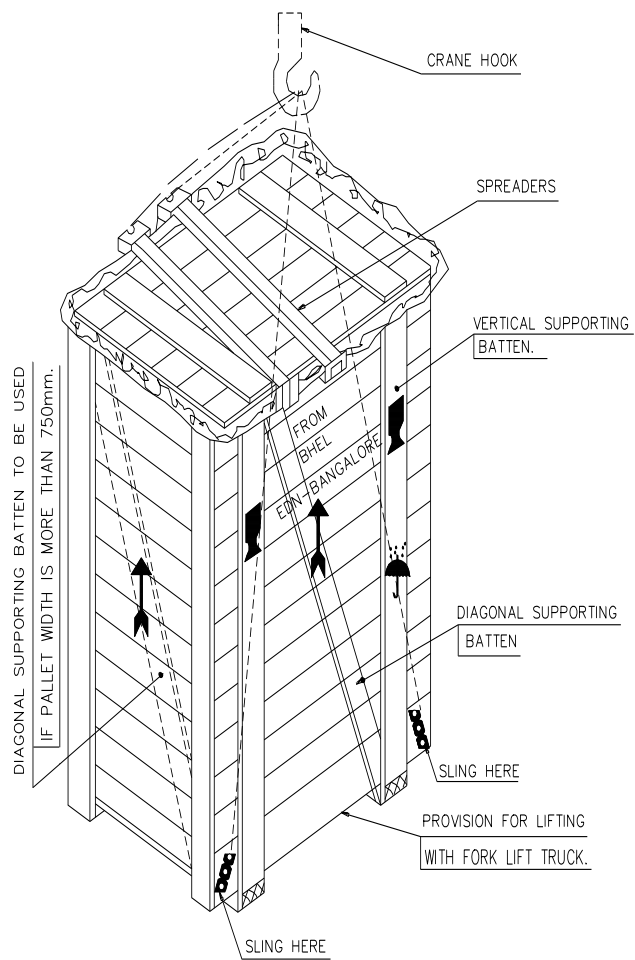

FIG-3 : LIFTING OF PACKED CASE.



A4 - 14

PLANT STANDARD

ED 049 00 99

REV NO 13

PAGE 15 OF 27

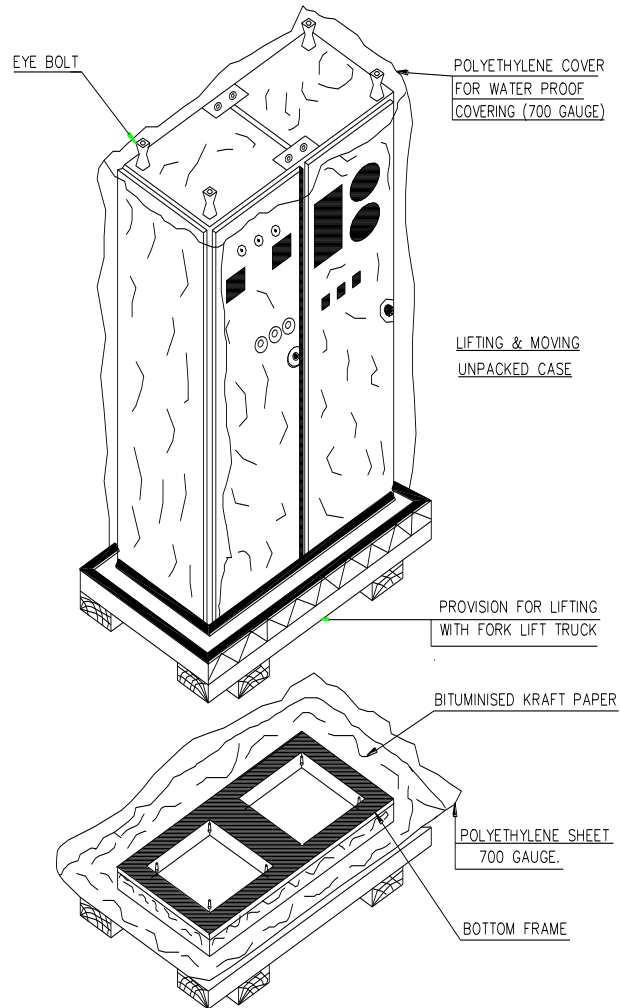

FIGURE-4



A4 - 14

PLANT STANDARD

ED 049 00 99

REV NO 13

PAGE 16 OF 27

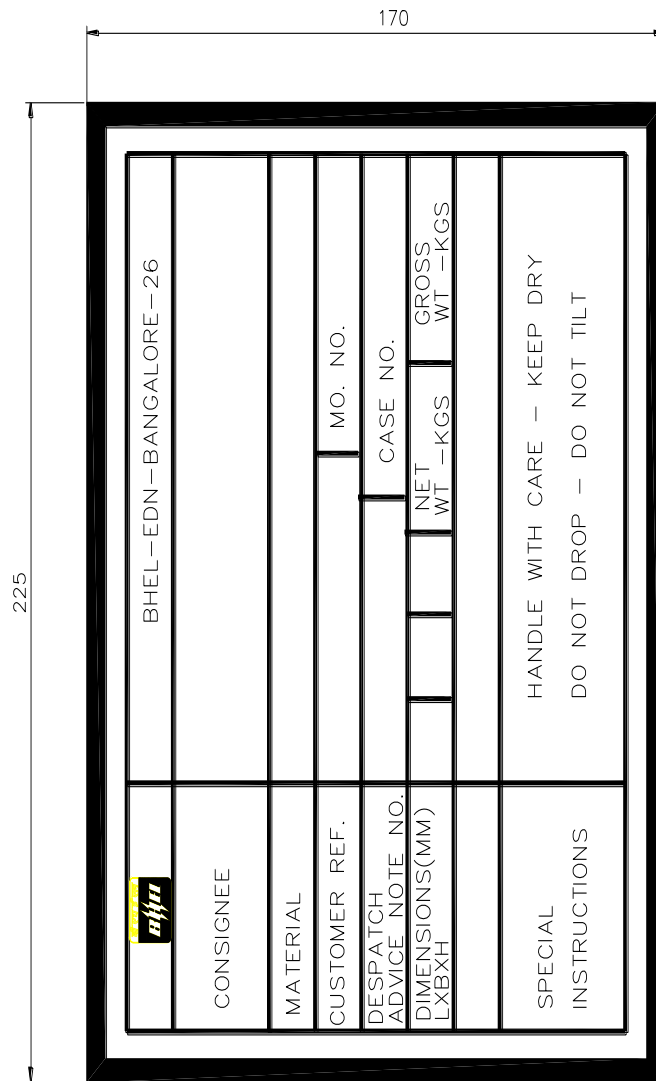

FIG-5 : MARKING PLATE.



A4 - 14

PLANT STANDARD

ED 049 00 99

REV NO 13

PAGE 17 OF 27

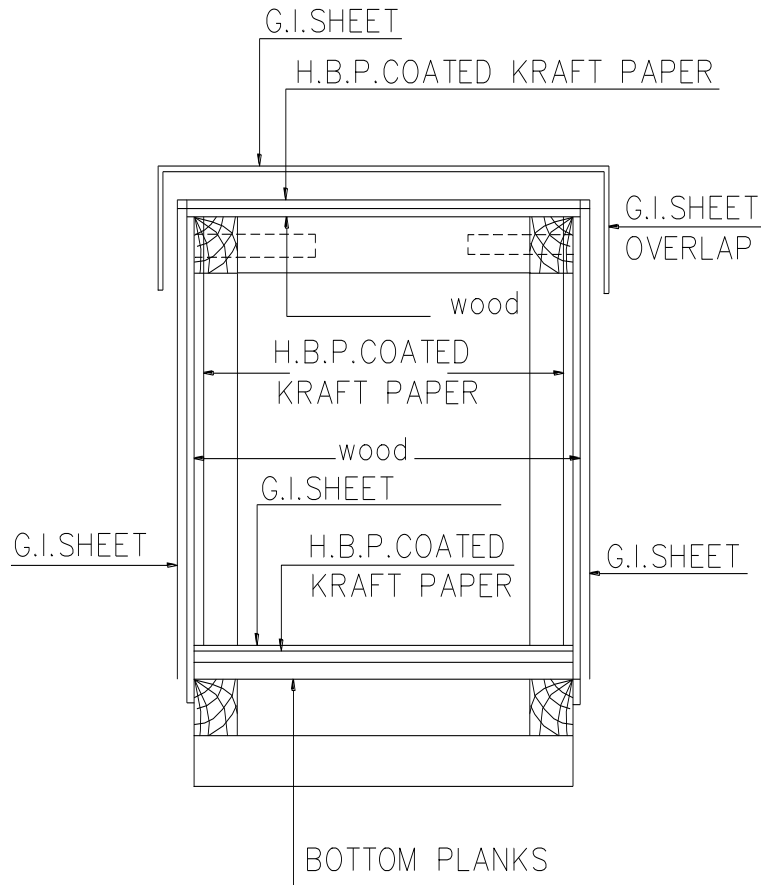

FIG-6 : CLOSED PACKING CASE WITH G.I.SHEET
SHOWING LAYERS OF PACKING MATERIALS.



A4 - 14

PLANT STANDARD

ED 049 00 99

REV NO 13

PAGE 19 OF 27

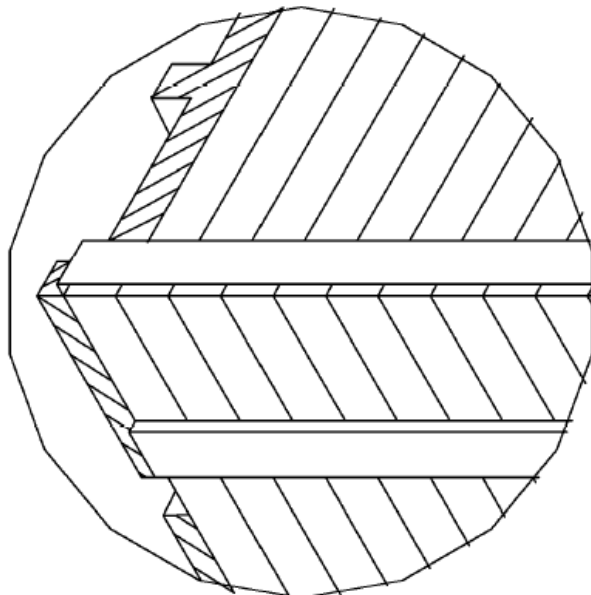
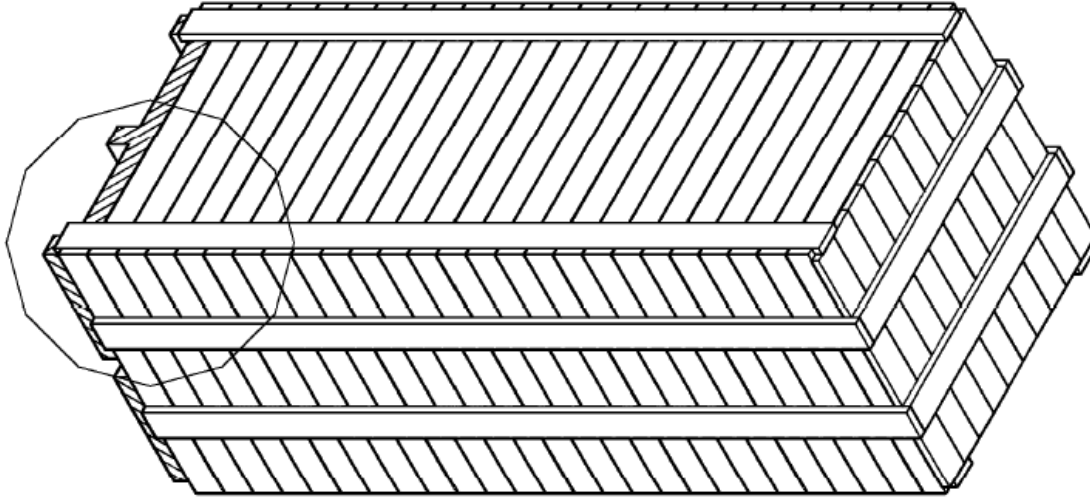

Fig – 8 : Single Suit Cubicle Packing View



A4 - 14

PLANT STANDARD

ED 049 00 99

REV NO 13

PAGE 20 OF 27

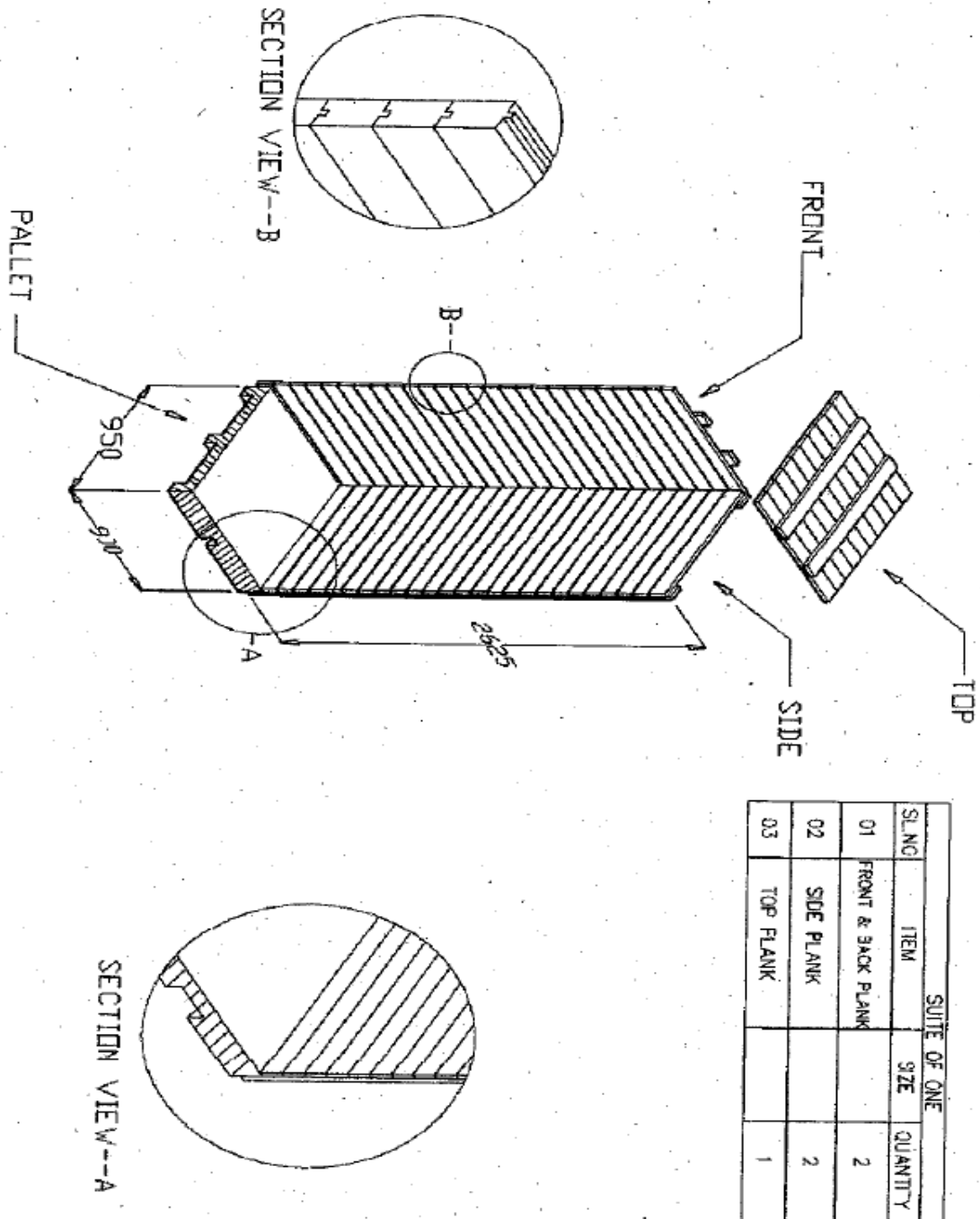

Fig - 9 : Single Suit Packing Assembly Drawing



A4 - 14

PLANT STANDARD

ED 049 00 99

REV NO 13

PAGE 21 OF 27

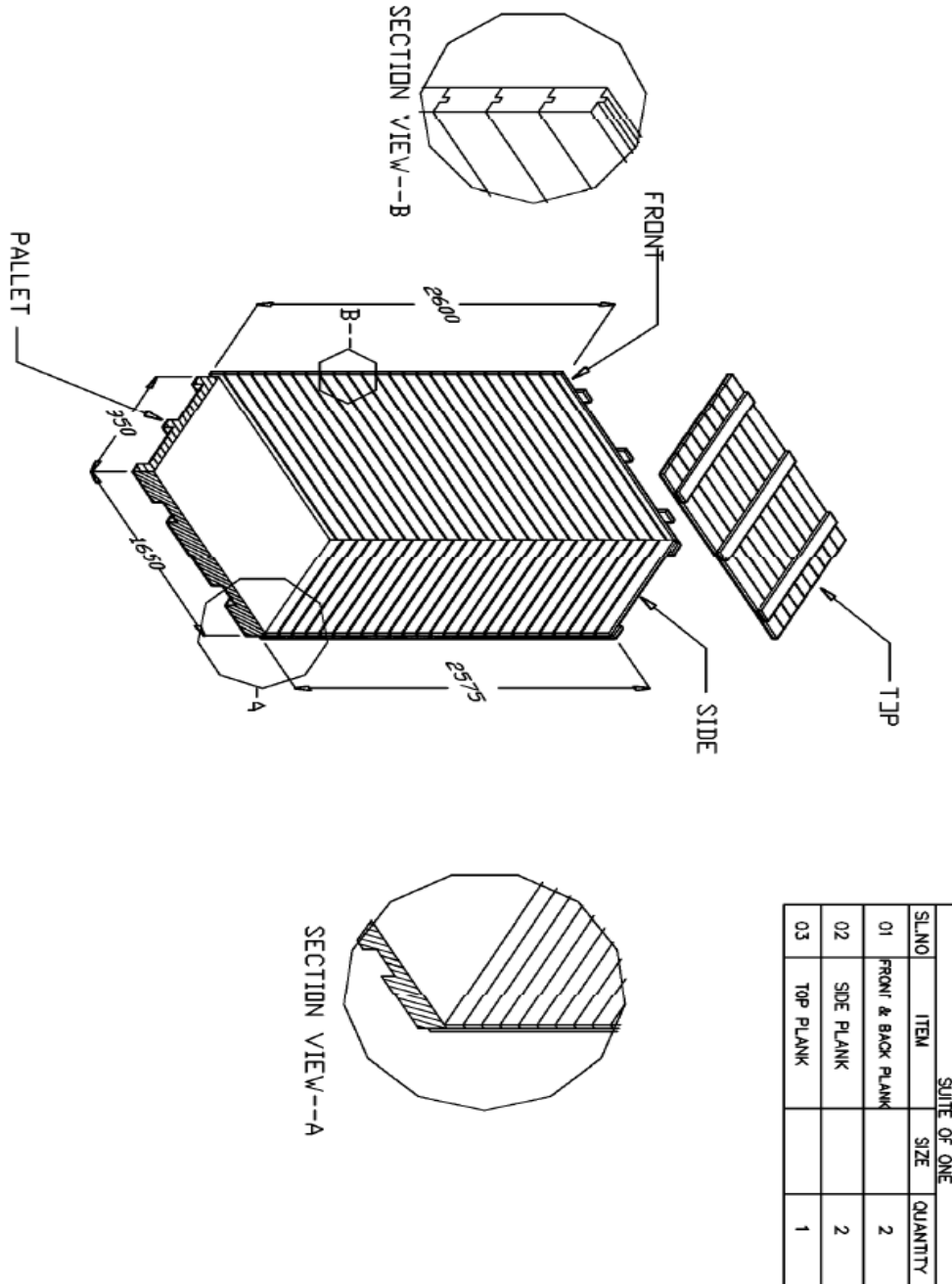

Fig – 10 : Two Suit Packing Assembly Details



A4 - 14

PLANT STANDARD

ED 049 00 99

REV NO 13

PAGE 22 OF 27

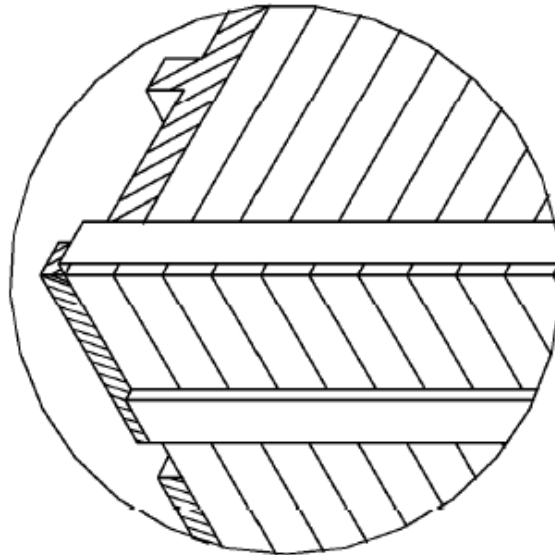
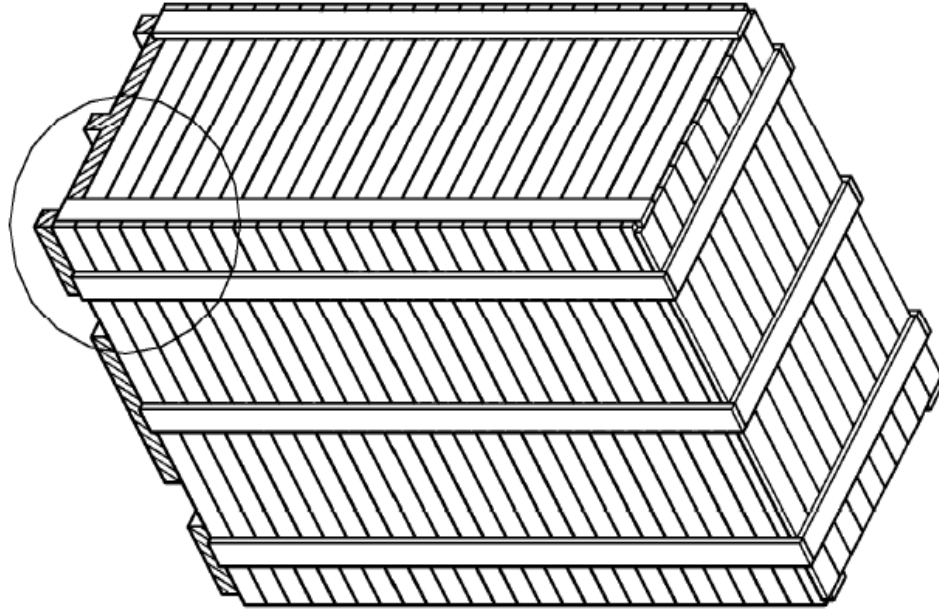

Fig – 11 : Two Suit Panel Packed view



A4 - 14

PLANT STANDARD

ED 049 00 99

REV NO 13

PAGE 23 OF 27

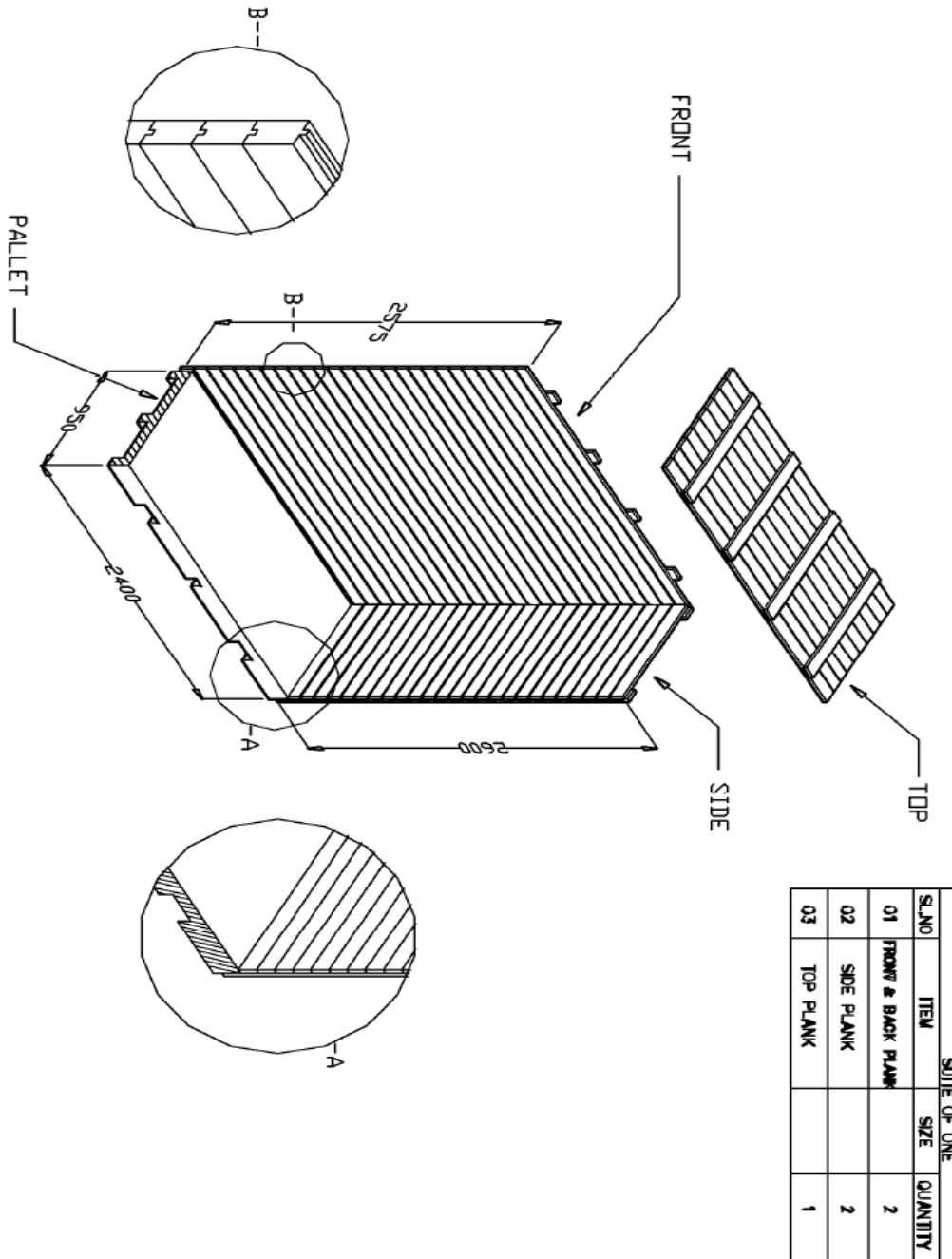

SL.NO	ITEM	SIZE	QUANTITY
01	FRONT & BACK PLANK		2
02	SIDE PLANK		2
03	TOP PLANK		1

Fig – 12 : Three Suit Panel Packing Assembly View



A4 - 14

PLANT STANDARD

ED 049 00 99

REV NO 13

PAGE 24 OF 27

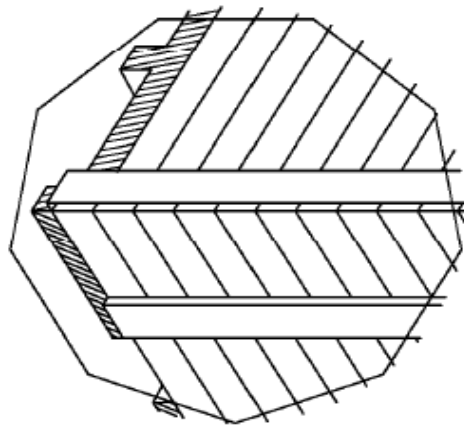
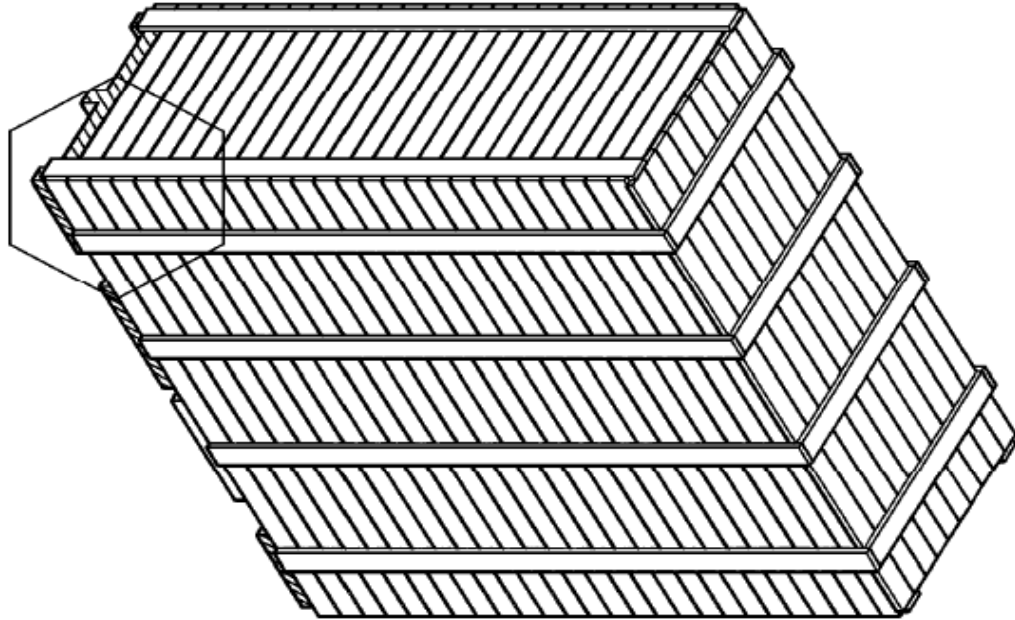

Fig -13 : Three Suit Panel Packed View



A4 - 14

PLANT STANDARD

ED 049 00 99

REV NO 13

PAGE 25 OF 27

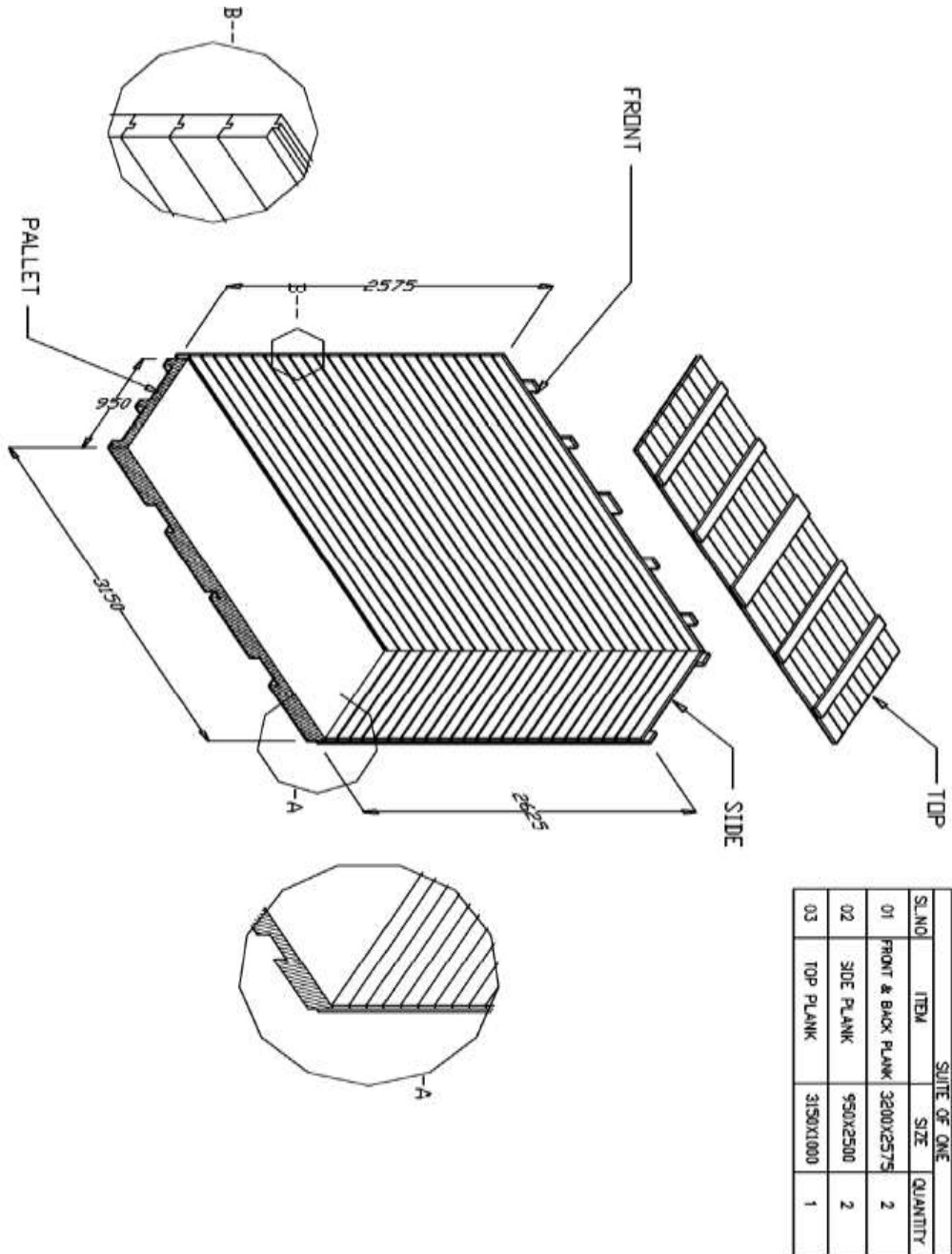

Fig – 14 : Four Suit Panel Packing assembly Detail



A4 - 14

PLANT STANDARD

ED 049 00 99

REV NO 13

PAGE 26 OF 27

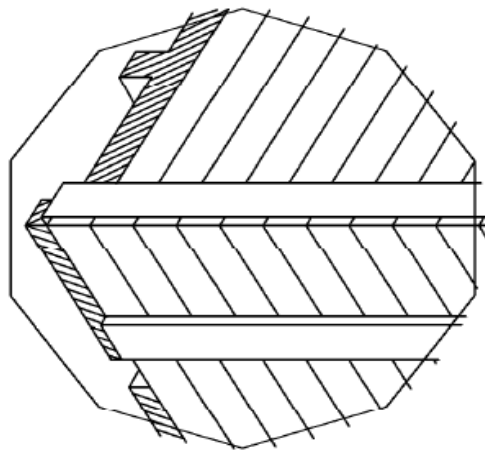
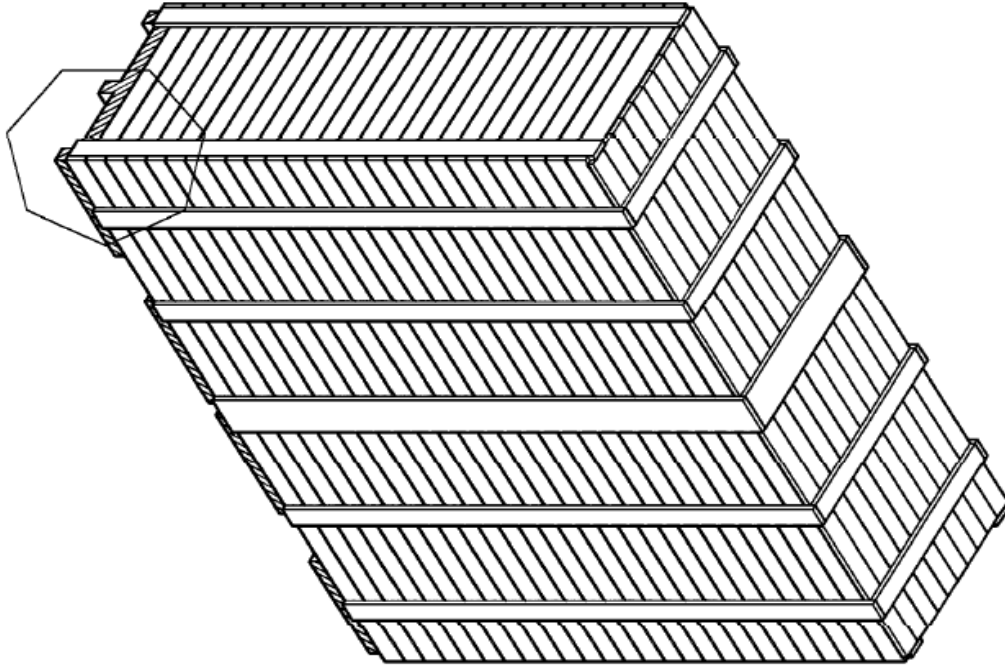

Fig -15 : Four Suit Panel Packing View



A4 - 14

PLANT STANDARD

ED 049 00 99

REV NO 13

PAGE 27 OF 27

Easy spares [Initial and O&M] Traceability and Identification at units and as well as at sites:

Fig: 16

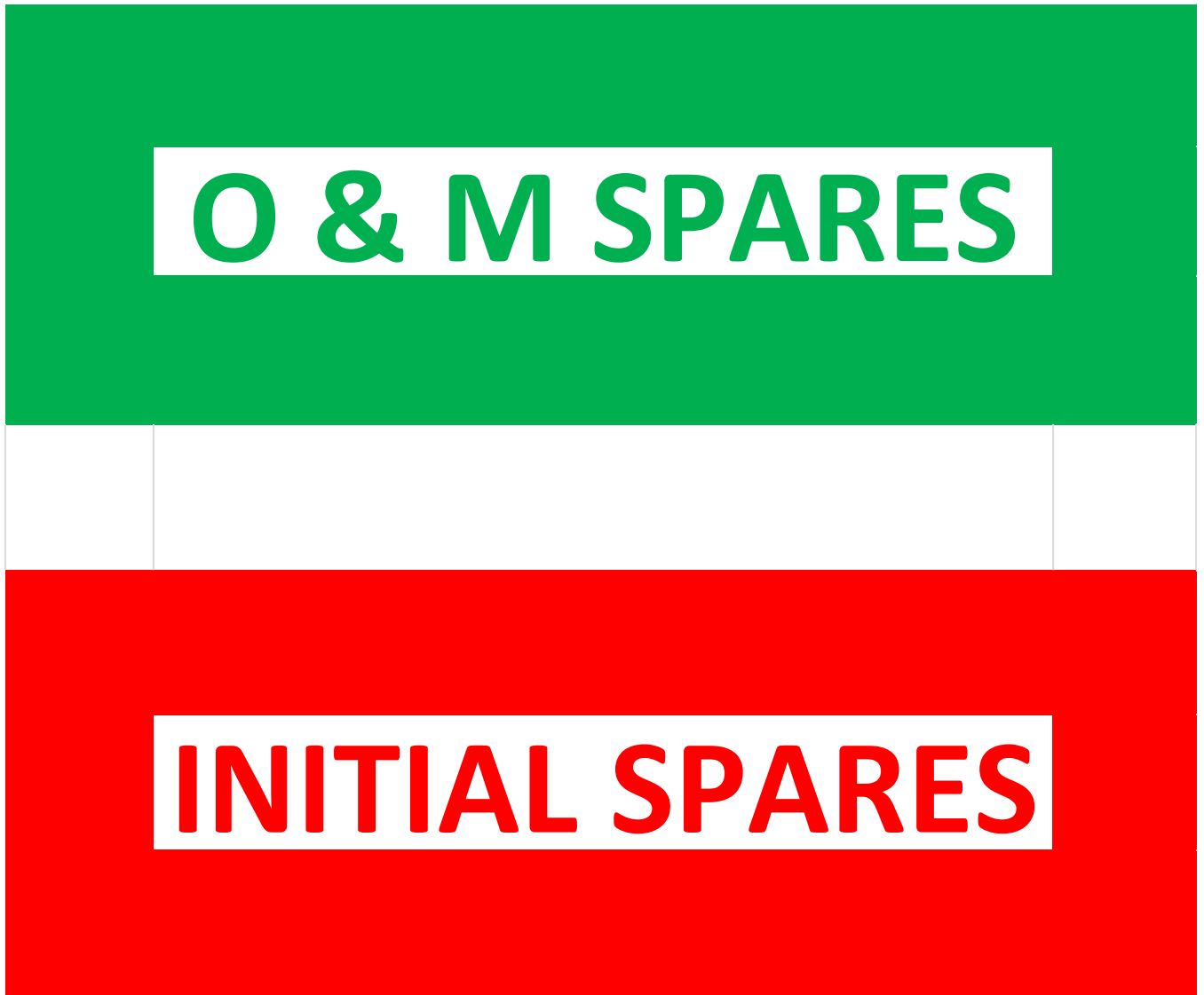

PART – II A [AS PER BHEL PLANT STANDARD NO. ED 049 00 99 REV 13]
UNPRICED "PRICE BID" FORMAT [PLEASE ENTER "YES " OR "NO " ONLY]

SI No	Type of Packing	Unit	QTY FOR 2 YEARS (2018-20)		PLEASE ENTER " YES" if Quoted or " NO " if not Quoted	If " YES" , PLEASE ENTER the Type of TAXES QUOTED (SGST/CGST)	PLEASE ENTER % of TAXES QUOTED	HSN code	Indicative Item Wise Weightage for Schedule A
1	Packing of Cubicles with Rubber Wood as described at 3.1 of Part - I 'A' of Tender Specification & Plant Standard Ref : ED 049 00 99 Rev 13	Cubic Metre of wood content	2400	Material Cost					
				Packing charge					
				SUB-TOTAL					72% -73%
2	Packing of Cubicles with Silver Oak / Pine wood as described at 3.2 of Part-I 'A' of Tender Specification & Plant Standard Ref : ED 049 00 99 Rev 13	Cubic Metre of wood content	240	Material Cost					
				Packing charge					
				SUB-TOTAL					10% - 11%
3	Packing of Loose Items with Rubber Wood As described at 3.4 of Part-I 'A' of Tender Specification & Plant Standard Ref : ED 049 00 99 Rev 13	Cubic Metre of wood content	480	Material Cost					
				Packing charge					
				SUB-TOTAL					14% - 15%
4	Packing of Loose Items with Silver Oak / Pine wood as described at 3.5 of Part-I 'A' of Tender Specification & Plant Standard Ref : ED 049 00 99 Rev 13	Cubic Metre of wood content	60	Material Cost					
				Packing charge					
				SUB-TOTAL					2% - 3%
5	Packing with Bitumen Coated Hessein Cloth etc., as described at 3.7 of Part-I 'A' of Tender Specification & Plant Standard Ref : ED 049 00 99 Rev 13	Square Metre	2400	Material Cost					
				Packing charge					
				SUB-TOTAL					< 1%

Note : Bidders Quoting for Schedule PART-II A to ensure all items are quoted for in the Schedule. No Item to be left Blank
Also do not fill anything in the shaded boxes.

SI No	Type of Packing	Unit	QTY FOR 2 YEARS (2018-20)		PLEASE ENTER " YES" if Quoted or " NO" if not Quoted	If " YES" , PLEASE ENTER the Type of TAXES QUOTED (SGST/CGST)	PLEASE ENTER % of TAXES QUOTED	HSN code	Indicative Item Wise Weightage for Schedule B	
1	Packing of Cubicles with Plywood along with plywood support batten and other details as described under Part-I 'B' using... [Ref plant std ED 0490092]									
	a) 12 mm thick Comml Plywood - MR Grade IS:303 [ref clause 6.1 of plant std ED 0490092]	Square Metre of Plywood	11250	Material Cost					18%-19%	
				Packing charge						
				SUB-TOTAL						
	b) 12 mm thick Comml Plywood - BWR Grade IS : 303 [ref clause 6.1 of plant std ED 0490092]	Square Metre of Plywood	1500	Material Cost					2% - 3%	
				Packing charge						
				SUB-TOTAL						
	c) 12 mm thick Plywood - Marine Grade IS : 710 [clause 6.2 of plant std Ed 0490092]	Square Metre of Plywood	450	Material Cost					< 1%	
				Packing charge						
				SUB-TOTAL						
	2	Packing of Cubicles with Plywood and silver oak wooden support batten as described under 6.0 to 6.1.8 of Part-I 'B' [ref figures 4 and 5 of plant std ED 0490092]								
		a) 12 mm thick Comml Plywood - MR Grade IS:303	Square Metre of Plywood	4500	Material Cost					7% - 8%
Packing charge										
SUB-TOTAL										
b) 12 mm thick Comml Plywood - BWR Grade IS : 303		Square Metre of Plywood	750	Material Cost					1% - 2%	
				Packing charge						
				SUB-TOTAL						
c) 12 mm thick Plywood - Marine Grade IS : 710 [clause 6.2 of plant std Ed 0490092]		Square Metre of Plywood	450	Material Cost					< 1%	
				Packing charge						
				SUB-TOTAL						

SI No	Type of Packing	Unit	QTY FOR 2 YEARS (2018-20)		PLEASE ENTER "YES" if Quoted or "NO" if not Quoted	If " YES" , PLEASE ENTER the Type of TAXES QUOTED (SGST/CGST)	PLEASE ENTER % of TAXES QUOTED	HSN code	Indicative Item Wise Weightage for Schedule B
3	Packing of Cubicles like Railways and equivalent bigger / heavier size panels with Plywood along with plywood support batten , mechanical latching unit or suitable nut & bolt and other details are as described under 6.0 to 6.1.8 of Part-I 'B' [ref figures 8 and 7 of plant std ED 0490092]								
	a) 12 mm thick Comml Plywood - MR Grade IS:303	Square Metre of Plywood	5250	Material Cost					10%-11%
				Packing charge					
				SUB-TOTAL					
	b) 12 mm thick Comml Plywood - BWR Grade IS : 303	Square Metre of Plywood	487.5	Material Cost					1% - 2%
				Packing charge					
				SUB-TOTAL					
	c) 12 mm thick Plywood - Marine Grade IS : 710	Square Metre of Plywood	195	Material Cost					< 1%
				Packing charge					
				SUB-TOTAL					
4	Packing of Cubicles like Railways and equivalent bigger / heavier size panels with Plywood along with Silveroak support batten and other details are as described under 6.0 to 6.1.8 of Part-I 'B' [ref figures 9 of plant std ED 0490092]								
	a) 12 mm thick Comml Plywood - MR Grade IS:303	Square Metre of Plywood	4500	Material Cost					8%-9%
				Packing charge					
				SUB-TOTAL					
	b) 12 mm thick Comml Plywood - BWR Grade IS : 303	Square Metre of Plywood	487.5	Material Cost					1% - 2%
				Packing charge					
				SUB-TOTAL					
	c) 12 mm thick Plywood - Marine Grade IS : 710	Square Metre of Plywood	195	Material Cost					< 1%
				Packing charge					
				SUB-TOTAL					

SI No	Type of Packing	Unit	QTY FOR 2 YEARS (2018-20)		PLEASE ENTER "YES" if Quoted or "NO" if not Quoted	If " YES" , PLEASE ENTER the Type of TAXES QUOTED (SGST/CGST)	PLEASE ENTER % of TAXES QUOTED	HSN code	Indicative Item Wise Weightage for Schedule B
5	Packing of Loose items / spares and other items with Plywood along with plywood support batten and other details are as described under 6.0 to 6.1.8 of Part-I 'B' using [ref figures 13 of plant std ED 0490092]								
	a) 12 mm thick Comml Plywood - MR Grade IS:303	Unit Square Metre of Plywood	4500	Material Cost					8%-9%
				Packing charge					
				SUB-TOTAL					
	b) 12 mm thick Comml Plywood - BWR Grade IS : 303	Unit Square Metre of Plywood	750	Material Cost					1% - 2%
				Packing charge					
				SUB-TOTAL					
	c) 12 mm thick Plywood - Marine Grade IS : 710	Unit Square Metre of Plywood	750	Material Cost					1% - 2%
				Packing charge					
SUB-TOTAL									
6	Packing of Loose items / spares and other items with Plywood along with silver oak wood support batten and other details are as described under 6.0 to 6.1.8 of Part-I 'B' using [ref figures 4 of plant std ED 0490092]								
	a) 12 mm thick Comml Plywood - MR Grade IS:303	Unit Square Metre of Plywood	3000	Material Cost					5% - 6%
				Packing charge					
				SUB-TOTAL					
	b) 12 mm thick Comml Plywood - BWR Grade IS : 303	Unit Square Metre of Plywood	750	Material Cost					1% - 2%
				Packing charge					
				SUB-TOTAL					
	c) 12 mm thick Plywood - Marine Grade IS : 710	Unit Square Metre of Plywood	750	Material Cost					1% - 2%
				Packing charge					
SUB-TOTAL									

SI No	Type of Packing	Unit	QTY FOR 2 YEARS (2018-20)		PLEASE ENTER "YES" if Quoted or "NO" if not Quoted	If " YES" , PLEASE ENTER the Type of TAXES QUOTED (SGST/CGST)	PLEASE ENTER % of TAXES QUOTED	HSN code	Indicative Item Wise Weightage for Schedule B
7	Packing of items suitable for speedpost / courier service using 12 mm Thick Commercial Plywood [MR grade] for sides and 6 mm Thick Commercial Plywood for Top and Bottom with all other Packing Materials including Bitumen kraft Paper covering using Gum . Sketch enclosed ref: 805-RPP- BOX - 001	Per Square Metre	6000	Material Cost					5% - 6%
				Packing charge					
				SUB-TOTAL					
8	Packing of items suitable for Speedpost using all sides with 12 mm Thick Commercial Plywood [MR Grade] general purpose with other following pkg materials: Silicagel, Polythene Cover for items, PVC strappings and markings. [No rubber wood supporting battens] sketch enclosed ref: .805 - RPP - BOX - 001	Per Square Metre	7500	Material Cost					8% - 9%
				Packing charge					
				SUB-TOTAL					
9	LABOUR CHARGE for packing of materials in plywood using all other materials except plywood. [If Plywood supplied by BHEL.] PACKING CHARGE ONLY	Per Square Metre	1950						< 1%
				Packing charge					
				SUB-TOTAL					

SI No	Type of Packing	Unit	QTY FOR 2 YEARS (2018-20)	PLEASE ENTER "YES" if Quoted or "NO" if not Quoted	If " YES" , PLEASE ENTER the Type of TAXES QUOTED (SGST/CGST)	PLEASE ENTER % of TAXES QUOTED	HSN code	Indicative Item Wise Weightage for Schedule B
10	Supply & Packing of HVDC Thyristor Modules using following Bolted type Plywood box with MR grade as per IS:303, having internal size of 1256 x 874 x 398 mm with ply wood pallet and EPE [Expanded poly ethylene] foam fitments of high density, special Dessicant(Crystal form) of 10 bags of 250 grams each, 200 microns polythene cover and other items/accessories(Like EP foam sheets, Tarfelt, Packing note holder, name plate, Address labels, BHEL Monogram, Fragile mark, Chain marks, GI nuts, Bolts & washers) as per BOM & BHEL Document no.GI1369SH16600105 for packing procedure of thyristor modules							
	a) 12 mm thick Comml Plywood - MR Grade IS:303 [ref clause 6.1 of plant std ED 0490092]	per box	564	Material Cost				11% - 12%
				Packing charge				
				SUB-TOTAL				
	Alternatively vendor has to quote for the below type also:							
	Supply & Packing of HVDC Thyristor Modules using following Bolted type Plywood box with MR grade as per IS:303, having internal size of 1256 x 874 x 398 mm with ply wood pallet and EPP [Expanded polypropylene] foam fitments of high density, special Dessicant(Crystal form) of 10 bags of 250 grams each, 200 microns polythene cover and other items/accessories(Like EP foam sheets, Tarfelt, Packing note holder, name plate, Address labels, BHEL Monogram, Fragile mark, Chain marks, GI nuts, Bolts & washers) as per BOM & BHEL Document no.GI1369SH16600105 for packing procedure of thyristor modules							
	a) 12 mm thick Comml Plywood - MR Grade IS:303 [ref clause 6.1 of plant std ED 0490092]	per box	564	Material Cost				11% - 12%
				Packing charge				
				SUB-TOTAL				
	Note : Bidders Quoting for Schedule PART-II B to ensure all items are quoted for in the Schedule. No Item to be left Blank							
	Also do not fill anything in the shaded boxes.							

Part – II [C]									
PART II C PACKING OF PV MODULES AS PER BHEL DRAWINGS									
UNPRICED "PRICE BID" FORMAT [PLEASE ENTER "YES " OR "NO " ONLY]									
SI No	Type of Packing	Unit	QTY FOR 2 YEARS (2018-20)		PLEASE ENTER " YES" if Quoted or " NO " if not Quoted	If " YES" , PLEASE ENTER the Type of TAXES QUOTED (SGST/CGST)	PLEASE ENTER % of TAXES QUOTED	HSN code	Indicative Item Wise Weightage for Schedule C
1	Packing of Pv Modules L24270P in 28 in 1	NO OF BOXES	5000	Material Cost					80%
				Packing charge					
				SUB-TOTAL					
2	Packing of Pv Modules L20220 in 28 in 1	NO OF BOXES	1400	Material Cost					20%
				Packing charge					
				SUB-TOTAL					

Note : Bidders Quoting for Schedule PART-II C to ensure all items are quoted for in the Schedule. No Item to be left Blank
Also do not fill anything in the shaded boxes.

Packing consumables to be supplied by the contractor

UNPRICED "PRICE BID" FORMAT [PLEASE ENTER "YES" OR "NO" ONLY]

SI No	Item Description	Unit	QTY FOR 2 YEARS (2018-20)	PLEASE ENTER "YES" if Quoted or "NO" if not Quoted	If "YES", PLEASE ENTER the Type of TAXES QUOTED (SGST/CGST)	PLEASE ENTER % of TAXES QUOTED	HSN code	Indicative Item Wise Weightage for Schedule D
1	Silicagel	Kgs.	200					1% - 2%
2	Polythene Sheet (175 Micron)	Kgs.	200					2% - 3%
3	Polythene Sheet (200 Micron)	Kgs.	200					2% - 3%
4	Iron Clamps	Each	100					< 1%
5	Hoop Iron (0.6 mm Thick)	Kgs.	200					1% - 2%
6	Rubberised Coir	Kgs.	400					1% - 2%
7	Tarfelt	Square Mtrs.	500					1% - 2%
8	Nails (2" and 2 – ½")	Kgs.	250					1% - 2%
9	Packing Note Holder	Each	400					< 1%
10	Name Plate	Each	400					1% - 2%
11	Bituminised Water Proof Kraft Paper	Square Metres	300					< 1%
12	Plywood of 6 mm thk MR Grade	Sq mtrs	300					6% - 7%
13	Ply wood 12 mm thick of MR Grade	Sq mtrs	300					8% - 9%
14	Air Bubble Roll of 1.5 m wide x 100 mtrs long or equivalent qty having Dia of air bubble :9.5 mm or more and 450 Gauge.	Roll	50					7% - 8%
15	2 Ply corrugated paper roll [Non vergin] of 100 GSM size : 1 m x 100 m long	roll	50					3% - 4%
16	EP foam sheets of size : 1000 mm x 500 mm x 50 mm thick with normal density	no	800					13% - 14%

Part – II [D]

Packing consumables to be supplied by the contractor

UNPRICED "PRICE BID" FORMAT [PLEASE ENTER "YES" OR "NO" ONLY]

SI No	Item Description	Unit	QTY FOR 2 YEARS (2018-20)	PLEASE ENTER "YES" if Quoted or "NO" if not Quoted	If "YES", PLEASE ENTER the Type of TAXES QUOTED (SGST/CGST)	PLEASE ENTER % of TAXES QUOTED	HSN code	Indicative Item Wise Weightage for Schedule D
17	Expanded Polyethylene foam packing box for LEG Module Packing as per drawing 3-688-04-10022 ver 02	no	300					11% - 12%
18	Expanded Polyethylene foam Corner Block as per drawing having size : 250 x 250 x 200 mm with wall thickness of 50 mm	no	800					6% - 7%
19	Thermocole sheets size : 1m x 0.5 metre width x 15 mm thick of normal density	no	3000					5% - 6%
20	Nails suitable for speedpost parcels size : 14 G x 1.25 inch long	Kgs.	500					3% - 4%
21	GUM - utility Brand suitable for speed post parcel packing , qty : 700 ml bottle	no	200					< 1%
22	BOPP Gum Tapes [self adhesive] Size: 2" x 65 metre long roll heavy Guage	roll	500					1% - 2%
23	BOPP Gum Tapes [self adhesive] Size: 3" x 65 metre long roll heavy Guage	roll	400					1% - 2%
24	Labels - Vinyl(Stickers)	Sq.ft.	500					2% - 3%
25	Labels - Flex	Sq.ft.	2000					8% - 9%
26	"S" Labels of size 75mm x 75mm for initial spares	Each	1000					< 1%
27	"S" Labels of size 150mm x 150mm for initial spares	Each	1000					< 1%
28	"BHEL" monogram label of size 150mm x 200mm	Each	1000					1% - 2%

Note : Bidders Quoting for Schedule PART-II D to ensure all items are quoted for in the Schedule. No Item to be left Blank
 Also do not fill anything in the shaded boxes.

Part – II [E]

**PART II E SCHEDULE OF RATES FOR PACKING OF PANELS WITH GALVANISED IRON SHEET
UNPRICED "PRICE BID" FORMAT [PLEASE ENTER "YES " OR "NO " ONLY]**

SI No	Type of Packing	Unit	QTY FOR 2 YEARS (2018-20)		PLEASE ENTER " YES" if Quoted or " NO " if not Quoted	If " YES" , PLEASE ENTER the Type of TAXES QUOTED (SGST/CGST)	PLEASE ENTER % of TAXES QUOTED	HSN code	Indicative Item Wise Weightage for Schedule E
1	Packing of panels with Galvanised Iron Sheet of Thickness 0.3 mm + /- 0.05mm tolerance with suitable Nails & Wooden batten for covering packed cases	Square Metres of GI sheet	30000	Material Cost					100.00%
				Packing charge					
				SUB-TOTAL					

Note : Bidders Quoting for Schedule PART-II E to ensure all items are quoted for in the Schedule. No Item to be left Blank
Also do not fill anything in the shaded boxes.

PART – II A [AS PER BHEL PLANT STANDARD NO. ED 049 00 99 REV 13]										
PRICE BID FORMAT [PLEASE ENTER VALUES AND TAXES/DUTIES IN RESPECTIVE COLUMNS IN INDIAN RUPEES]										
SI No	Type of Packing	Unit	QTY FOR 2 YEARS (2018-20)		(A) - BASIC (Rs) in "figures"	(A) - BASIC (Rs) in "Words"	(B) - VALUE OF SGST & CGST in Rupees	RATE in Rs. (A+B)	TOTAL (Rs) = QTY* RATE	Indicative Item Wise Weightage for Schedule A
1	Packing of Cubicles with Rubber Wood as described at 3.1 of Part - 'A' of Tender Specification & Plant Standard Ref : ED 049 00 99 Rev 13	Cubic Metre of wood content	2400	Material Cost						
				Packing charge						
				SUB-TOTAL						72% -73%
2	Packing of Cubicles with Silver Oak / Pine wood as described at 3.2 of Part-I 'A' of Tender Specification & Plant Standard Ref : ED 049 00 99 Rev 13	Cubic Metre of wood content	240	Material Cost						
				Packing charge						
				SUB-TOTAL						10% - 11%
3	Packing of Loose Items with Rubber Wood As described at 3.4 of Part-I 'A' of Tender Specification & Plant Standard Ref : ED 049 00 99 Rev 13	Cubic Metre of wood content	480	Material Cost						
				Packing charge						
				SUB-TOTAL						14% - 15%
4	Packing of Loose Items with Silver Oak / Pine wood as described at 3.5 of Part-I 'A' of Tender Specification & Plant Standard Ref : ED 049 00 99 Rev 13	Cubic Metre of wood content	60	Material Cost						
				Packing charge						
				SUB-TOTAL						2% - 3%
5	Packing with Bitumen Coated Hessein Cloth etc., as described at 3.7 of Part-I 'A' of Tender Specification & Plant Standard Ref : ED 049 00 99 Rev 13	Square Metre	2400	Material Cost						
				Packing charge						
				SUB-TOTAL						< 1%

GRAND TOTAL IN FIG (Rs)	
GRAND TOTAL (IN WORDS)	

NAME :
SIGNATURE :
SEAL :

Note : Bidders Quoting for Schedule PART-II A to ensure all items are quoted for in the Schedule. No Item to be left Blank

PRICE BID FORMAT [PLEASE ENTER VALUES AND TAXES/DUTIES IN RESPECTIVE COLUMNS IN INDIAN RUPEES]

SI No	Type of Packing	Unit	QTY FOR 2 YEARS (2018-20)	(A) - BASIC (Rs) in "figures"	(A) - BASIC (Rs) in "Words"	(B) - VALUE OF SGST & CGST in Rupees	RATE in Rs. (A+B)	TOTAL (Rs) = QTY* RATE	Indicative Item Wise Weightage for Schedule B
1	Packing of Cubicles with Plywood along with plywood support batten and other details as described under Part-I 'B' using... [Ref plant std ED 0490092]								
	a) 12 mm thick Comml Plywood - MR Grade IS:303 [ref clause 6.1 of plant std ED 0490092]	Square Metre of Plywood	11250	Material Cost					18%-19%
Packing charge									
SUB-TOTAL									
	b) 12 mm thick Comml Plywood - BWR Grade IS : 303 [ref clause 6.1 of plant std ED 0490092]	Square Metre of Plywood	1500	Material Cost					2% - 3%
Packing charge									
SUB-TOTAL									
	c) 12 mm thick Plywood - Marine Grade IS : 710 [clause 6.2 of plant std ED 0490092]	Square Metre of Plywood	450	Material Cost					< 1%
Packing charge									
SUB-TOTAL									
2	Packing of Cubicles with Plywood and silver oak wooden support batten as described under 6.0 to 6.1.8 of Part-I 'B' [ref figures 4 and 5 of plant std ED 0490092]								
	a) 12 mm thick Comml Plywood - MR Grade IS:303	Square Metre of Plywood	4500	Material Cost					7% - 8%
Packing charge									
SUB-TOTAL									
	b) 12 mm thick Comml Plywood - BWR Grade IS : 303	Square Metre of Plywood	750	Material Cost					1% - 2%
Packing charge									
SUB-TOTAL									
	c) 12 mm thick Plywood - Marine Grade IS : 710 [clause 6.2 of plant std ED 0490092]	Square Metre of Plywood	450	Material Cost					< 1%
Packing charge									
SUB-TOTAL									

PRICE BID FORMAT [PLEASE ENTER VALUES AND TAXES/DUTIES IN RESPECTIVE COLUMNS IN INDIAN RUPEES]

SI No	Type of Packing	Unit	QTY FOR 2 YEARS (2018-20)	(A) - BASIC (Rs) in "figures"	(A) - BASIC (Rs) in "Words"	(B) - VALUE OF SGST & CGST in Rupees	RATE in Rs. (A+B)	TOTAL (Rs) = QTY* RATE	Indicative Item Wise Weightage for Schedule B
3	Packing of Cubicles like Railways and equivalent bigger / heavier size panels with Plywood along with plywood support batten , mechanical latching unit or suitable nut&bolt and other details are as described under 6.0 to 6.1.8 of Part-I 'B' [ref figures 8 and 7 of plant std ED 0490092]								
	a) 12 mm thick Comml Plywood - MR Grade IS:303	Square Metre of Plywood	5250	Material Cost					10%-11%
Packing charge									
SUB-TOTAL									
	b) 12 mm thick Comml Plywood - BWR Grade IS : 303	Square Metre of Plywood	487.5	Material Cost					1% - 2%
Packing charge									
SUB-TOTAL									
	c) 12 mm thick Plywood - Marine Grade IS : 710	Square Metre of Plywood	195	Material Cost					< 1%
Packing charge									
SUB-TOTAL									
4	Packing of Cubicles like Railways and equivalent bigger / heavier size panels with Plywood along with Silveroak support batten and other details are as described under 6.0 to 6.1.8 of Part-I 'B' [ref figures 9 of plant std ED 0490092]								
	a) 12 mm thick Comml Plywood - MR Grade IS:303	Square Metre of Plywood	4500	Material Cost					8%-9%
Packing charge									
SUB-TOTAL									
	b) 12 mm thick Comml Plywood - BWR Grade IS : 303	Square Metre of Plywood	487.5	Material Cost					1% - 2%
Packing charge									
SUB-TOTAL									
	c) 12 mm thick Plywood - Marine Grade IS : 710	Square Metre of Plywood	195	Material Cost					< 1%
Packing charge									
SUB-TOTAL									

PRICE BID FORMAT [PLEASE ENTER VALUES AND TAXES/DUTIES IN RESPECTIVE COLUMNS IN INDIAN RUPEES]

SI No	Type of Packing	Unit	QTY FOR 2 YEARS (2018-20)	(A) - BASIC (Rs) in "figures"	(A) - BASIC (Rs) in "Words"	(B) - VALUE OF SGST & CGST in Rupees	RATE in Rs. (A+B)	TOTAL (Rs) = QTY* RATE	Indicative Item Wise Weightage for Schedule B
5	Packing of Loose items / spares and other items with Plywood along with plywood support batten and other details are as described under 6.0 to 6.1.8 of Part-I 'B' using [ref figures 13 of plant std ED 0490092]								
	a) 12 mm thick Comml Plywood - MR Grade IS:303	Unit Square Metre of Plywood	4500	Material Cost					8%-9%
Packing charge									
SUB-TOTAL									
	b) 12 mm thick Comml Plywood - BWR Grade IS : 303	Unit Square Metre of Plywood	750	Material Cost					1% - 2%
Packing charge									
SUB-TOTAL									
	c) 12 mm thick Plywood - Marine Grade IS : 710	Unit Square Metre of Plywood	750	Material Cost					1% - 2%
Packing charge									
SUB-TOTAL									
6	Packing of Loose items / spares and other items with Plywood along with silver oak wood support batten and other details are as described under 6.0 to 6.1.8 of Part-I 'B' using [ref figures 4 of plant std ED 0490092]								
	a) 12 mm thick Comml Plywood - MR Grade IS:303	Unit Square Metre of Plywood	3000	Material Cost					5% - 6%
Packing charge									
SUB-TOTAL									
	b) 12 mm thick Comml Plywood - BWR Grade IS : 303	Unit Square Metre of Plywood	750	Material Cost					1% - 2%
Packing charge									
SUB-TOTAL									
	c) 12 mm thick Plywood - Marine Grade IS : 710	Unit Square Metre of Plywood	750	Material Cost					1% - 2%
Packing charge									
SUB-TOTAL									

PRICE BID FORMAT [PLEASE ENTER VALUES AND TAXES/DUTIES IN RESPECTIVE COLUMNS IN INDIAN RUPEES]

SI No	Type of Packing	Unit	QTY FOR 2 YEARS (2018-20)		(A) - BASIC (Rs) in "figures"	(A) - BASIC (Rs) in "Words"	(B) - VALUE OF SGST & CGST in Rupees	RATE in Rs. (A+B)	TOTAL (Rs) = QTY* RATE	Indicative Item Wise Weightage for Schedule B
7	Packing of items suitable for speedpost / courier service using 12 mm Thick Commercial Plywood [MR grade] for sides and 6 mm Thick Commercial Plywood for Top and Bottom with all other Packing Materials including Bitumen kraft Paper covering using Gum . Sketch enclosed ref: 805-RPP- BOX - 001	Per Square Metre	6000	Material Cost						5% - 6%
				Packing charge						
				SUB-TOTAL						
8	Packing of items suitable for Speedpost using all sides with 12 mm Thick Commercial Plywood [MR Grade] general purpose with other following pkg materials: Silicagel, Polythene Cover for items, PVC strappings and markings. [No rubber wood supporting battens] sketch enclosed ref: .805 - RPP - BOX - 001	Per Square Metre	7500	Material Cost						8% - 9%
				Packing charge						
				SUB-TOTAL						
9	LABOUR CHARGE for packing of materials in plywood using all other materials except plywood. [If Plywood supplied by BHEL.] PACKING CHARGE ONLY	Per Square Metre	1950							< 1%
				Packing charge						
				SUB-TOTAL						

PRICE BID FORMAT [PLEASE ENTER VALUES AND TAXES/DUTIES IN RESPECTIVE COLUMNS IN INDIAN RUPEES]

SI No	Type of Packing	Unit	QTY FOR 2 YEARS (2018-20)	(A) - BASIC (Rs) in "figures"	(A) - BASIC (Rs) in "Words"	(B) - VALUE OF SGST & CGST in Rupees	RATE in Rs. (A+B)	TOTAL (Rs) = QTY* RATE	Indicative Item Wise Weightage for Schedule B
10	Supply & Packing of HVDC Thyristor Modules using following Bolted type Plywood box with MR grade as per IS:303, having internal size of 1256 x 874 x 398 mm with ply wood pallet and EPE [Expanded poly ethylene] foam fitments of high density, special Dessicant(Crystal form) of 10 bags of 250 grams each, 200 microns polythene cover and other items/accessories(Like EP foam sheets, Tarfelt, Packing note holder, name plate, Address labels, BHEL Monogram, Fragile mark, Chain marks, GI nuts, Bolts & washers) as per BOM & BHEL Document no.GI1369SH16600105 for packing procedure of thyristor modules .								
	a) 12 mm thick Comml Plywood - MR Grade IS:303 [ref clause 6.1 of plant std ED 0490092]	per box	564	Material Cost					11% - 12%
Packing charge									
SUB-TOTAL									
Alternatively vendor has to quote for the below type also:									
Supply & Packing of HVDC Thyristor Modules using following Bolted type Plywood box with MR grade as per IS:303, having internal size of 1256 x 874 x 398 mm with ply wood pallet and EPP [Expanded polypropylene] foam fitments of high density, special Dessicant(Crystal form) of 10 bags of 250 grams each, 200 microns polythene cover and other items/accessories(Like EP foam sheets, Tarfelt, Packing note holder, name plate, Address labels, BHEL Monogram, Fragile mark, Chain marks, GI nuts, Bolts & washers) as per BOM & BHEL Document no.GI1369SH16600105 for packing procedure of thyristor modules									
	a) 12 mm thick Comml Plywood - MR Grade IS:303 [ref clause 6.1 of plant std ED 0490092]	per box	564	Material Cost					11% - 12%
Packing charge									
SUB-TOTAL									
							GRAND TOTAL IN FIG (Rs)		
							GRAND TOTAL (IN WORDS)		
							NAME :		
							SIGNATURE :		
							SEAL :		
Note : Bidders Quoting for Schedule PART-II B to ensure all items are quoted for in the Schedule. No Item to be left Blank									

Part – II [C]										
PART II C PACKING OF PV MODULES AS PER BHEL DRAWINGS										
PRICE BID FORMAT [PLEASE ENTER VALUES AND TAXES/DUTIES IN RESPECTIVE COLUMNS IN INDIAN RUPEES]										
Sl No	Type of Packing	Unit	QTY FOR 2 YEARS (2018-20)		(A) - BASIC (Rs) in "figures"	(A) - BASIC (Rs) in "Words"	(B) - VALUE OF SGST & CGST in Rupees	RATE in Rs. (A+B)	TOTAL (Rs) = QTY* RATE	Indicative Item Wise Weightage for Schedule C
1	Packing of Pv Modules L24270P in 28 in 1	NO OF BOXES	5000	Material Cost						80%
				Packing charge						
				SUB-TOTAL						
2	Packing of Pv Modules L20220 in 28 in 1	NO OF BOXES	1400	Material Cost						20%
				Packing charge						
				SUB-TOTAL						
								GRAND TOTAL IN FIG (Rs)		
								GRAND TOTAL (IN WORDS)		

NAME :
SIGNATURE :
SEAL :

Note : Bidders Quoting for Schedule PART-II C to ensure all items are quoted for in the Schedule. No Item to be left Blank

Part – II [D]									
Packing consumables to be supplied by the contractor									
PRICE BID FORMAT [PLEASE ENTER VALUES AND TAXES/DUTIES IN RESPECTIVE COLUMNS IN INDIAN RUPEES]									
SI No	Item Description	Unit	QTY FOR 2 YEARS (2018-20)	(A) - BASIC (Rs) in "figures"	(A) - BASIC (Rs) in "Words"	(B) - VALUE OF SGST & CGST in Rupees	RATE in Rs. (A+B)	TOTAL (Rs) = QTY* RATE	Indicative Item Wise Weightage for Schedule D
1	Silicagel	Kgs.	200						1% - 2%
2	Polythene Sheet (175 Micron)	Kgs.	200						2% - 3%
3	Polythene Sheet (200 Micron)	Kgs.	200						2% - 3%
4	Iron Clamps	Each	100						< 1%
5	Hoop Iron (0.6 mm Thick)	Kgs.	200						1% - 2%
6	Rubberised Coir	Kgs.	400						1% - 2%
7	Tarfelt	Square Mtrs.	500						1% - 2%
8	Nails (2" and 2 – ½")	Kgs.	250						1% - 2%
9	Packing Note Holder	Each	400						< 1%
10	Name Plate	Each	400						1% - 2%
11	Bituminised Water Proof Kraft Paper	Square Metres	300						< 1%
12	Plywood of 6 mm thk MR Grade	Sq mtrs	300						6% - 7%
13	Ply wood 12 mm thick of MR Grade	Sq mtrs	300						8% - 9%
14	Air Bubble Roll of 1.5 m wide x 100 mtrs long or equivalent qty having Dia of air bubble :9.5 mm or more and 450 Gauge.	Roll	50						7% - 8%
15	2 Ply corrugated paper roll [Non vergin] of 100 GSM size : 1 m x 100 m long	roll	50						3% - 4%
16	EP foam sheets of size : 1000 mm x 500 mm x 50 mm thick with normal density	no	800						13% - 14%

Part – II [D]									
Packing consumables to be supplied by the contractor									
PRICE BID FORMAT [PLEASE ENTER VALUES AND TAXES/DUTIES IN RESPECTIVE COLUMNS IN INDIAN RUPEES]									
Sl No	Item Description	Unit	QTY FOR 2 YEARS (2018-20)	(A) - BASIC (Rs) in "figures"	(A) - BASIC (Rs) in "Words"	(B) - VALUE OF SGST & CGST in Rupees	RATE in Rs. (A+B)	TOTAL (Rs) = QTY* RATE	Indicative Item Wise Weightage for Schedule D
17	Expanded Polyethylene foam packing box for LEG Module Packing as per drawing 3-688-04-10022 ver 02	no	300						11% - 12%
18	Expanded Polyethylene foam Corner Block as per drawing having size : 250 x 250 x 200 mm with wall thickness of 50 mm	no	800						6% - 7%
19	Thermocole sheets size : 1m x 0.5 metre width x 15 mm thick of normal density	no	3000						5% - 6%
20	Nails suitable for speedpost parcels size : 14 G x 1.25 inch long	Kgs.	500						3% - 4%
21	GUM - utility Brand suitable for speed post parcel packing , qty : 700 ml bottle	no	200						< 1%
22	BOPP Gum Tapes [self adhesive] Size: 2" x 65 metre long roll heavy Guage	roll	500						1% - 2%
23	BOPP Gum Tapes [self adhesive] Size: 3" x 65 metre long roll heavy Guage	roll	400						1% - 2%
24	Labels - Vinyl(Stickers)	Sq.ft.	500						2% - 3%
25	Labels - Flex	Sq.ft.	2000						8% - 9%
26	"S" Labels of size 75mm x 75mm for initial spares	Each	1000						< 1%
27	"S" Labels of size 150mm x 150mm for initial spares	Each	1000						< 1%
28	"BHEL" monogram label of size 150mm x 200mm	Each	1000						1% - 2%

GRAND TOTAL IN FIG (Rs)

GRAND TOTAL (IN WORDS)

NAME :

SIGNATURE :

SEAL :

Note : Bidders Quoting for Schedule PART-II D to ensure all items are quoted for in the Schedule. No Item to be left Blank

Part – II [E]										
PART II F SCHEDULE OF RATES FOR PACKING OF PANELS WITH GALVANISED IRON SHEET										
PRICE BID FORMAT [PLEASE ENTER VALUES AND TAXES/DUTIES IN RESPECTIVE COLUMNS IN INDIAN RUPEES										
SI No	Type of Packing	Unit	QTY FOR 2 YEARS (2018-20)		(A) - BASIC (Rs) in "figures"	(A) - BASIC (Rs) in "Words"	(B) - VALUE OF SGST & CGST in Rupees	RATE in Rs. (A+B)	TOTAL (Rs) = QTY* RATE	Indicative Item Wise Weightage for Schedule E
1	Packing of panels with Galvanised Iron Sheet of Thickness 0.3 mm +/- 0.05mm tolerance with suitable Nails & Wooden batten for covering packed cases	Square Metres of GI sheet	30000	Material Cost						100.00%
				Packing charge						
				SUB-TOTAL						
GRAND TOTAL IN FIG (Rs)										
GRAND TOTAL (IN WORDS)										
NAME :										
SIGNATURE :										
SEAL :										

Note : Bidders Quoting for Schedule PART-II E to ensure all items are quoted for in the Schedule. No Item to be left Blank

66200 70 679 3
DRAWING NO. 02 00399

COPYRIGHT AND CONFIDENTIAL

The information on this document is the property of Bharat Heavy Electricals Limited. It must not be used directly or indirectly in anyway detrimental to the interest of the Company

PART NO. (1) SLEEVE (CORRUGATED CARTON BOX) - 1 NO.

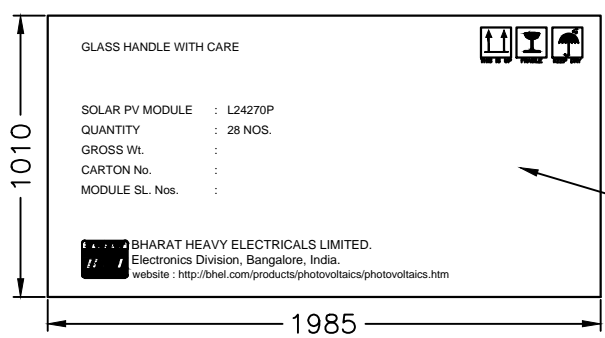

TEXT TO PRINTED IN BLUE COLOUR ON THIS SIDE

SLEEVE INNER DIMENSION

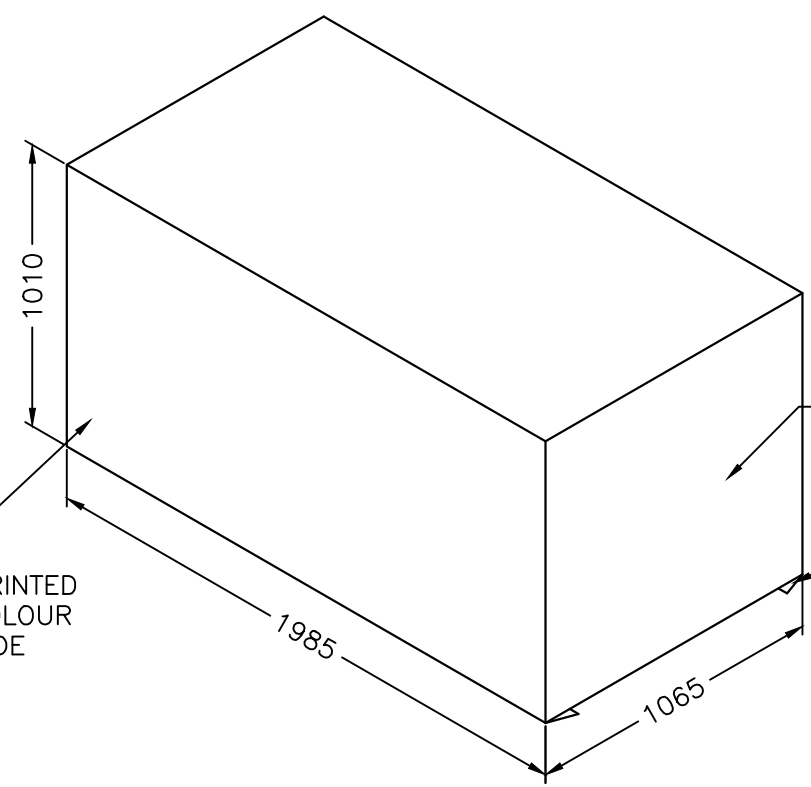

TOP COVER INNER DIMENSION

PART NO. (2) TOP COVER (CORRUGATED CARTON) - 1 NO.

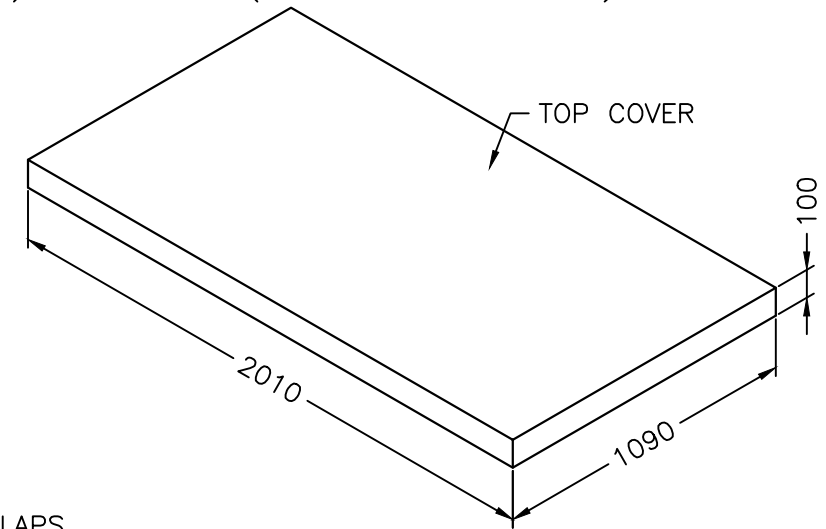

THE DIMENSIONS OF SLEEVE AND TOP COVER ARE INNER DIMENSIONS

PART NO. (3) PLYWOOD PALLET - 1 NO.

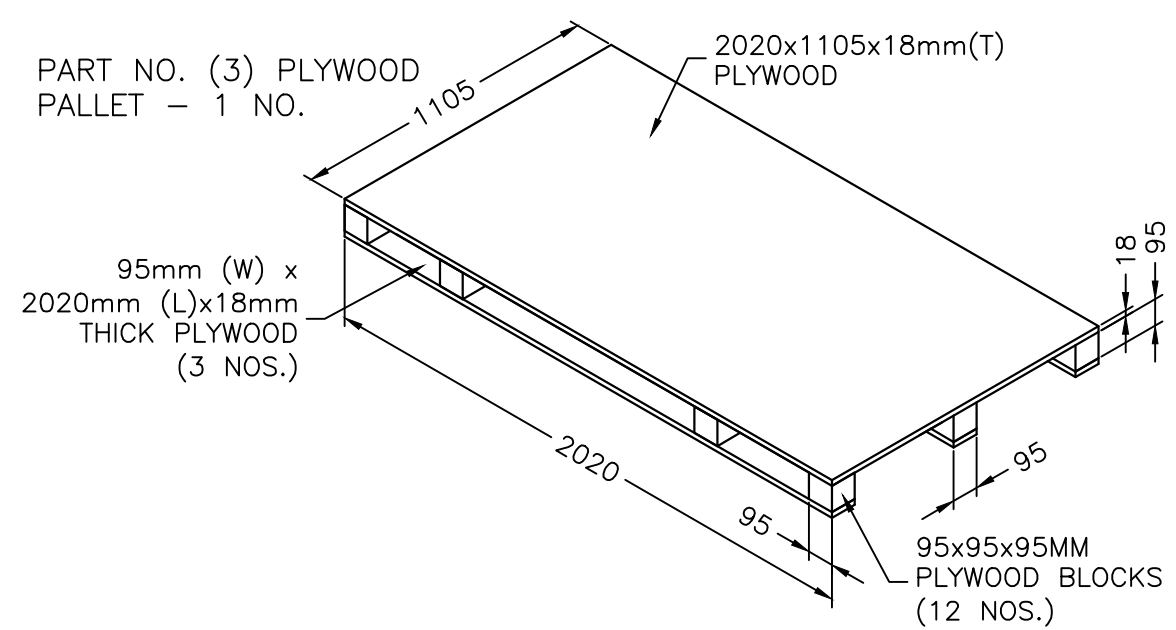

SPECIFICATIONS

PAPER COMBINATION : 469/200/180/200/180/200/469 GSM
 PAPER COLOUR : BROWN
 FLUTE TYPE : AAA OR ACB
 NO OF PLY : 7 PLY

SLEEVE

TOP COVER

300/180/200/180/200 GSM
 BROWN
 AC
 5 PLY

NOTES :

1. ALL THE DIMENSIONS ARE IN MM.
2. FLUTE DIRECTION TO BE ALONG HEIGHT OF THE BOX.
3. SLEEVE & FLAP ARE TO BE FORMED FROM SAME CORRUGATED SHEET.
4. PLEASE SEE PAGE NO. 2 FOR INSTRUCTIONS FOR PACKING OF PV MODULES.

PART NO. (4) BOTTOM SHEET-1No OF 1975x1065mm, 5 PLY 250/180/180/180/250 GSM SHEET

PART NO. (5) MODULE CORNER CAP - 112 NOS. 150x150mm, THICKNESS 0.6 TO 1.0mm

PART NO. (6) RETAINER STRIP - 2 NOS. 1265x100mm, 3 PLY.

TYPE OF PRODUCT OR NAME OF CUSTOMER/PROJECT

BHARAT HEAVY ELECTRICALS LIMITED. ELECTRONICS DIVISION, BANGALORE	DRN	SAN	Sd/-	290315	No. OF VAR
	CKD	SM	Sd/-	290315	
	APPD	SR	Sd/-	290315	

REV.	DATE	ALTERED	REV.	DATE	ALTERED	REV.	DATE	ALTERED
		CHECKED			CHECKED			CHECKED
		APPROVED			APPROVED	00		APPROVED
						FIRST ISSUE		

DEPT. SC&PV	FOR UNSPECIFIED-TOLERANCES REFER ED 0230499	SCALE NTS	WEIGHT(Kg)	REF. TO ASSY. DRG.	ITEM NO.	No. OF ITEM
CODE 439						
TITLE PACKING BOX FOR L24270P - 28 IN 1				DRAWING NO. 3 679 02 00399		REV. 00
SHEET NO. 01			NO. OF SHEETS 02			

DRAWING NO. 3 679 02 00399

COPYRIGHT AND CONFIDENTIAL

The information on this document is the property of Bharat Heavy Electricals Limited. It must not be used directly or indirectly in anyway detrimental to the interest of the Company

INSTRUCTIONS FOR PACKING OF 28 NOS OF 300W MULTI PV MODULES (L24270P)

1. SCREW THE CARTON BOX ON TO THE WOODEN PALLET.
2. PLACE 5 PLY CARTON SHEET OF DIMENSION 1975x1065 MM AT THE BOTTOM OF THE BOX.
3. PLACE CORNER CAPS SUITABLE TO MATCH FRAME PROFILE AT THE FOUR CORNERS OF THE PV MODULE.
4. PLACE 28 NOS. OF PV MODULES WITH CORNER CAPS INSIDE THE BOX.
5. PUT 1 NO. RETAINER STRIP (1265x100 MM) AT EACH END OF THE BOX ON THE MODULES.
6. CLOSE THE CARTON WITH THE TOP COVER.
7. SELF ADHESIVE BHEL SPECIFIED COLOR STICKER OF SIZE 100x100 MM. TO BE AFFIXED ON THE PRINTING SIDE.
8. WRITE THE CARTON BOX NO. & PUT A PACKING SLIP ON PRINTING SIDE INDICATING SL. NO., MODULE SL. NO. & PMAX.
9. WRAP THE CARTON BOX TIGHTLY ALONG WITH WOODEN PALLET WITH BALE PATI AT TWO PLACES EACH ON WIDTH AND LENGTH SIDE.
10. WRAP THE CARTON BOX WITH A POLYETHYLENE STRETCH WRAP ALL ROUND FOR PROTECTING AGAINST RAIN.
11. STACK AND STORE THE PACKED BOXES IN A SAFE PLACE.

TYPE OF PRODUCT OR NAME OF CUSTOMER/PROJECT												
BHARAT HEAVY ELECTRICALS LIMITED. ELECTRONICS DIVISION, BANGALORE								DRN	NAME	SIGN.	DATE	No. OF VAR
								CKD	SM	Sd/-	290315	
								APPD	SR	Sd/-	290315	
DEPT. SC&PV	FOR UNSPECIFIED-TOLERANCES REFER ED 0230499		SCALE	WEIGHT(Kg)	REF. TO ASSY. DRG.	ITEM NO.	No. OF ITEM					
CODE 439		NTS										
TITLE						DRAWING NO.		REV.				
PACKING BOX FOR L24270P - 28 IN 1						3 679 02 00399		00				
						SHEET NO. 02		NO. OF SHEETS 02				

REV.	DATE	ALTERED	REV.	DATE	ALTERED	REV.	DATE	ALTERED
		CHECKED			CHECKED	00		CHECKED
		APPROVED			APPROVED			APPROVED
						FIRST ISSUE		

DRAWING NO. 3 679 02 00407

COPYRIGHT AND CONFIDENTIAL
The information on this document is the property of Bharat Heavy Electricals Limited.
It must not be used directly or indirectly in any way detrimental to the interest of the Company

PART NO. (1) SLEEVE (CORRUGATED CARTON BOX) - 1 NO.

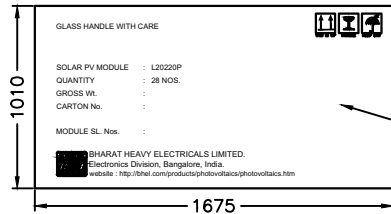

TEXT TO PRINTED IN BLUE COLOUR ON THIS SIDE

SLEEVE INNER DIMENSION

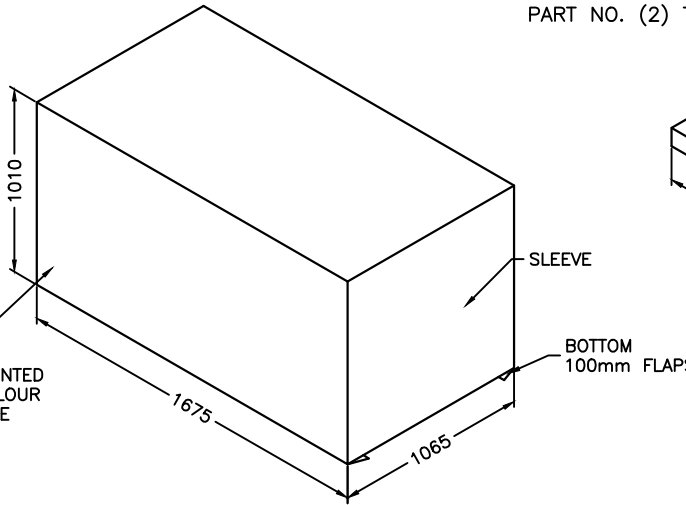

TOP COVER INNER DIMENSION

PART NO. (2) TOP COVER (CORRUGATED CARTON) - 1 NO.

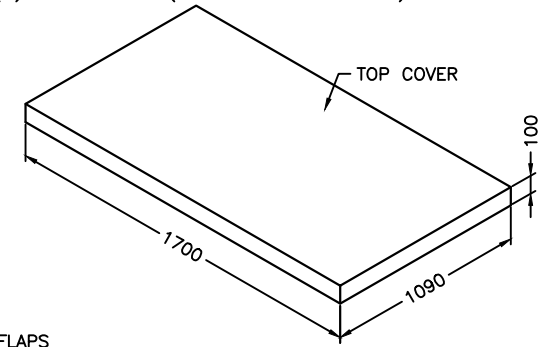

THE DIMENSIONS OF SLEEVE AND TOP COVER ARE INNER DIMENSIONS

PART NO. (3) PLYWOOD PALLET - 1 NO.

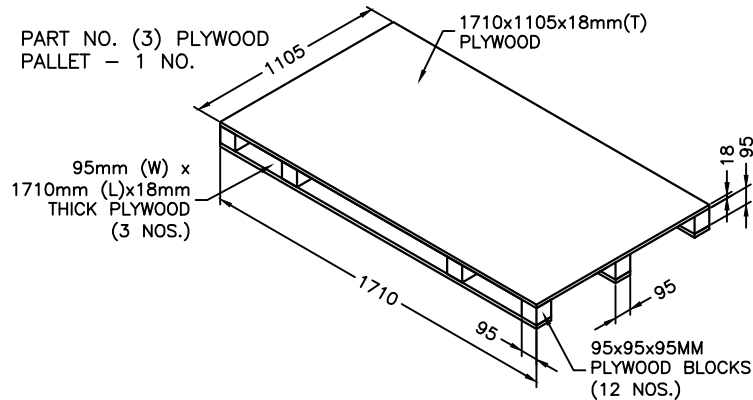

SPECIFICATIONS

PAPER COMBINATION : 469/200/180/200/180/200/469 GSM
PAPER COLOUR : BROWN
FLUTE TYPE : AAA OR ACB
NO OF PLY : 7 PLY

SLEEVE

TOP COVER

300/180/200/180/200 GSM
BROWN
AC
5 PLY

NOTES :

1. ALL THE DIMENSIONS ARE IN MM.
2. FLUTE DIRECTION TO BE ALONG HEIGHT OF THE BOX.
3. SLEEVE & FLAP ARE TO BE FORMED FROM SAME CORRUGATED SHEET.
4. PLEASE SEE PAGE NO. 2 FOR INSTRUCTIONS FOR PACKING OF PV MODULES.

PART NO. (4) BOTTOM SHEET-1No OF 1665x1065mm, 5 PLY 250/180/180/180/250 GSM SHEET

PART NO. (5) MODULE CORNER CAP - 112 NOS. 150x150mm, THICKNESS 0.6 TO 1.0mm

PART NO. (6) RETAINER STRIP - 2 NOS. 1265x100mm, 3 PLY.

TYPE OF PRODUCT OR NAME OF CUSTOMER/PROJECT				
---	--	--	--	--

	BHARAT HEAVY ELECTRICALS LIMITED. ELECTRONICS DIVISION, BANGALORE				No. OF VAR
	DRN	NAR	Sd/-	081215	
	CKD	SM	Sd/-	081215	
APPD	SR	Sd/-	081215		

DEPT. SC&PV	FOR UNSPECIFIED-TOLERANCES REFER ED 0230499	SCALE NTS	WEIGHT(Kg)	REF. TO ASSY. DRG.	ITEM NO.	No. OF ITEM
-------------	---	-----------	------------	--------------------	----------	-------------

TITLE	DRAWING NO.	REV.
PACKING BOX FOR L20220P - 28 IN 1	3 679 02 00407	00
SHEET NO. 01	NO. OF SHEETS 02	

REV.	DATE	ALTERED CHECKED	REV.	DATE	ALTERED CHECKED	REV.	DATE	ALTERED CHECKED
		APPROVED			APPROVED			APPROVED
						FIRST ISSUE		

DRAWING NO. 3 679 02 00407



COPYRIGHT AND CONFIDENTIAL
The information on this document is the property of Bharat Heavy Electricals Limited.
It must not be used directly or indirectly in anyway detrimental to the interest of the Company

INSTRUCTIONS FOR PACKING OF 28 NOS OF 250W MULTI PV MODULES (L20220P)

1. SCREW THE CARTON BOX ON TO THE WOODEN PALLET.
2. PLACE 5 PLY CARTON SHEET OF DIMENSION 1665x1065 MM AT THE BOTTOM OF THE BOX.
3. PLACE CORNER CAPS SUITABLE TO MATCH FRAME PROFILE AT THE FOUR CORNERS OF THE PV MODULE.
4. PLACE 28 NOS. OF PV MODULES WITH CORNER CAPS INSIDE THE BOX.
5. PUT 1 NO. RETAINER STRIP (1265x100 MM) AT EACH END OF THE BOX ON THE MODULES.
6. CLOSE THE CARTON WITH THE TOP COVER.
7. SELF ADHESIVE BHEL SPECIFIED COLOR STICKER OF SIZE 100x100 MM. TO BE AFFIXED ON THE PRINTING SIDE.
8. WRITE THE CARTON BOX NO. & PUT A PACKING SLIP ON PRINTING SIDE INDICATING SL. NO., MODULE SL. NO. & PMAX.
9. WRAP THE CARTON BOX TIGHTLY ALONG WITH WOODEN PALLET WITH BALE PATI AT TWO PLACES EACH ON WIDTH AND LENGTH SIDE.
10. WRAP THE CARTON BOX WITH A POLYETHYLENE STRETCH WRAP ALL ROUND FOR PROTECTING AGAINST RAIN.
11. STACK AND STORE THE PACKED BOXES IN A SAFE PLACE.

INVENTORY NO. SIGN & DATE REF. DRG.NO.

REV.	DATE	ALTERED	REV.	DATE	ALTERED	REV.	DATE	ALTERED
		CHECKED			CHECKED	00		CHECKED
		APPROVED			APPROVED			APPROVED
						FIRST ISSUE		

TYPE OF PRODUCT OR NAME OF CUSTOMER/PROJECT												
	BHARAT HEAVY ELECTRICALS LIMITED. ELECTRONICS DIVISION, BANGALORE							DRN	NAME	SIGN.	DATE	No. OF VAR
	CKD	SM	Sd/-	081215								
	APPD	SR	Sd/-	081215								
DEPT. SC&PV	FOR UNSPECIFIED-TOLERANCES		SCALE	WEIGHT(Kg)	REF. TO ASSY. DRG.	ITEM NO.	No. OF ITEM					
CODE 439	REFER ED 0230499		NTS									
TITLE						DRAWING NO.		REV.				
PACKING BOX FOR L20220P - 28 IN 1						3 679 02 00407		00				
						SHEET NO. 02		NO. OF SHEETS 02				

FIRST ANGLE PROJECTION

DRAWING NO. 3 688 04 10022

COPYRIGHT AND CONFIDENTIAL
The information on this document is the property of Bharat Heavy Electricals Limited.
It must not be used directly or indirectly in any way detrimental to the interest of the Company

REF. DRG. NO.
SIGN & DATE
INVENTORY NO.

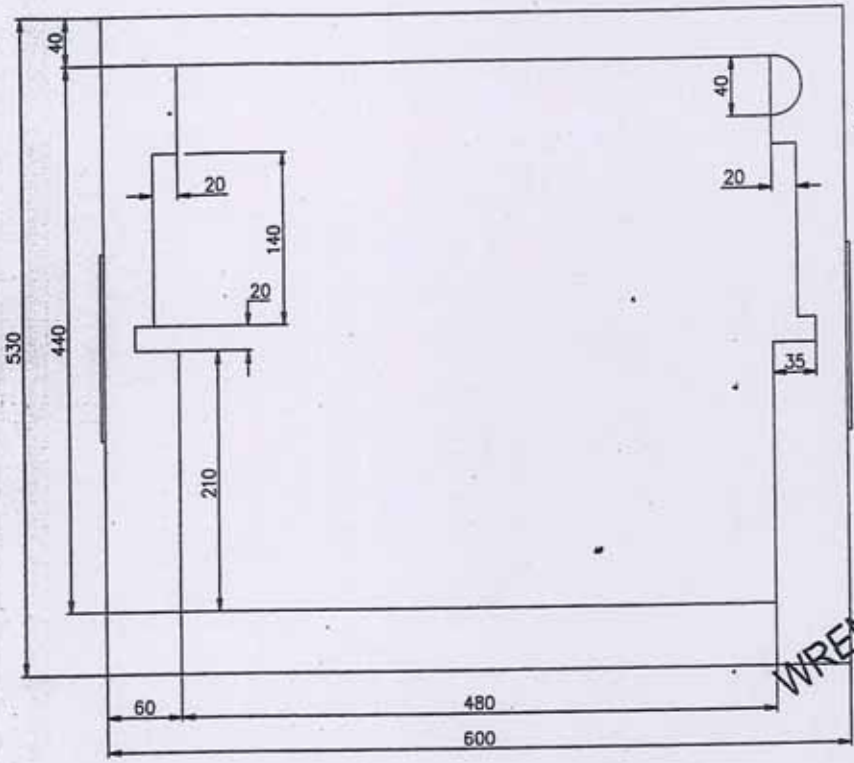

STICK-3mm PLYWOOD

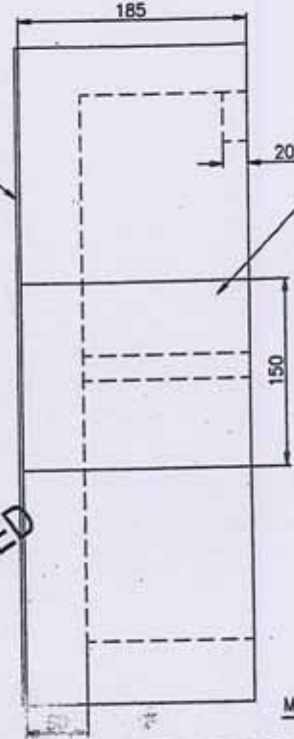

STICK-3mm PLYWOOD AT 2 -PLACES.
(BALE STRIP SHALL BE STRAPPED ON THIS PLYWOOD)

- NOTE:-
- 1.DIMENSIONAL TOLERANCE ± 3 mm
 - 2.THICKNESS TOLERANCE $\pm 10\%$
 - 3.DENSITY-32 TO 38 Kg/Cu.Mtr.
 - 4.REFER SHEET-02 FOR BOTTOM BOX.

MATERIAL:-EXPANDED POLYETHYLENE.

WRENCH RELEASED

QTY.	ITEM No.	DESCRIPTION	DRAWING NO.	ITEM No.	MATERIAL CODE	UT.WL (kg)
				VARIANT	MATERIAL SPECN.	QTY.
CARD TYPE 2				CARD TYPE 1		

TYPE OF PRODUCT OR NAME OF CUSTOMER/PROJECT: LEG MODULE-2.3 Kv

DRN	NAME	SIGN.	DATE	No. OF VAR
	G.MARUTHI		27.03.2001	
	KS.PRABHAKAR		27.03.2001	
	SHS RAO		27.03.2001	

DEPT. SAE	FOR UNSPECIFIED-TOLERANCES	SCALE	WEIGHT(Kg)	REF. TO ASSY. DRG.	ITEM NO.	No. OF ITEM
CODE 406	REFER ED 0230499	4:1				

TITLE	DRAWING NO.	REV.
PACKING BOX (TOP)	3 688 04 10022	02
	SHEET NO. 01	NO. OF SHEETS 02

REV.	DATE	ALTERED CHECKED	APPROVED	REV.	DATE	ALTERED CHECKED	APPROVED	REV.	DATE	ALTERED CHECKED	APPROVED
								01	30.10.05	ALTERED G.MARUTHI CHECKED NAGARAJU K APPROVED KG.RAVINDRAN	REVISED AND REDRAWN IN AUTOCAD. DIMEN ALTERED.

COPYRIGHT AND CONFIDENTIAL

The information on this document is the property of Bharat Heavy Electricals Limited. It must not be used directly or indirectly in anyway detrimental to the interest of the Company

DRAWING NO. 3 688 04 10022

STICK-3mm PLYWOOD AT 2-PLACES. (BALE STRIP SHALL BE STRAPPED ON THIS PLYWOOD)

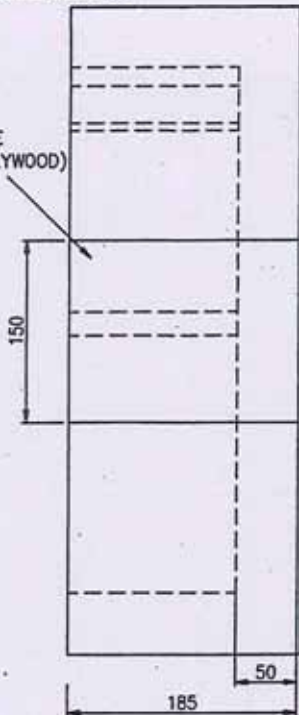

STICK-3mm PLYWOOD

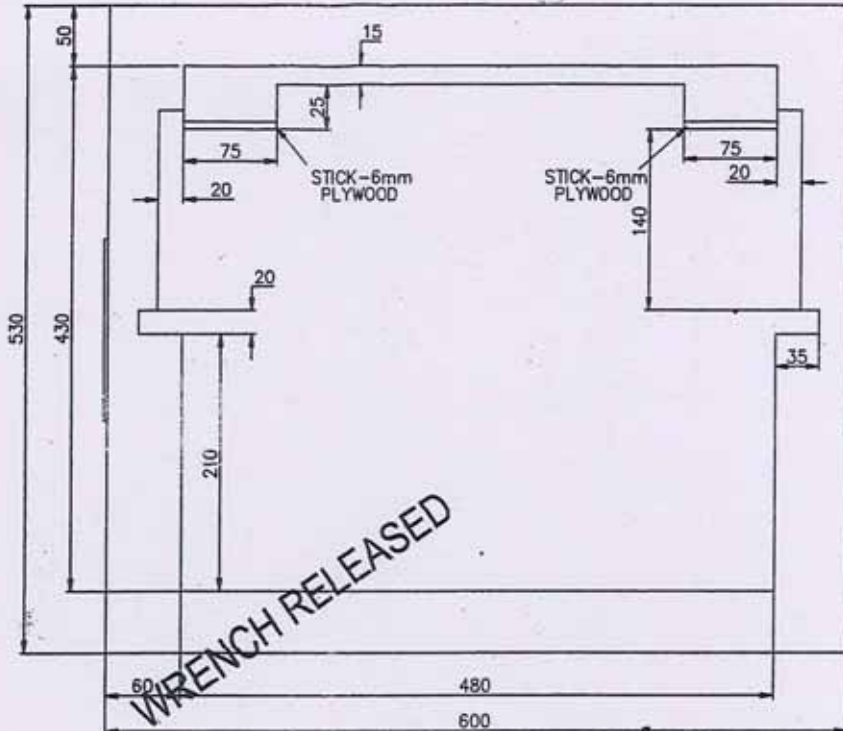

NOTE:-
1.FOR DETAILS REFER SHET No.01.

QTY.	ITEM No.	DESCRIPTION	DRAWING NO.	ITEM No. VARI ANT	MATERIAL CODE	UT.WL (kg)
					MATERIAL SPECN. <td>QTY. </td>	QTY.

← CARD TYPE 2 CARD TYPE 1 →

TYPE OF PRODUCT OR * NAME OF CUSTOMER/PROJECT LEG MODULE-2.3 Kv

DRN	NAME	SIGN.	DATE	No. OF VAR
G.MARUTHI			27.03.2001	
CKD	K.S.PRABHAKAR		27.03.2001	
APPD	SHS RAO		27.03.2001	

DEPT. SAE CODE 406	FOR UNSPECIFIED-TOLERANCES REFER ED 0230499	SCALE 4:1	WEIGHT(Kg)	REF. TO ASSY. DRG.	ITEM NO.	No. OF ITEM
--------------------	---	-----------	------------	--------------------	----------	-------------

TITLE	DRAWING NO.	REV.
PACKING BOX (BOTTOM)	3 688 04 10022	02
SHEET NO. 02	NO. OF SHEETS 02	

INVENTORY NO.	SIGN & DATE	REF. DRG.NO.

REV.	DATE	ALTERED CHECKED	APPROVED	REV.	DATE	ALTERED CHECKED	APPROVED
01	30.10.05	G.MARUTHI CHECKED	NAGARAJU K APPROVED				

REVISED AND REDRAWN IN AUTOCAD. DIMEN: ALTERED.

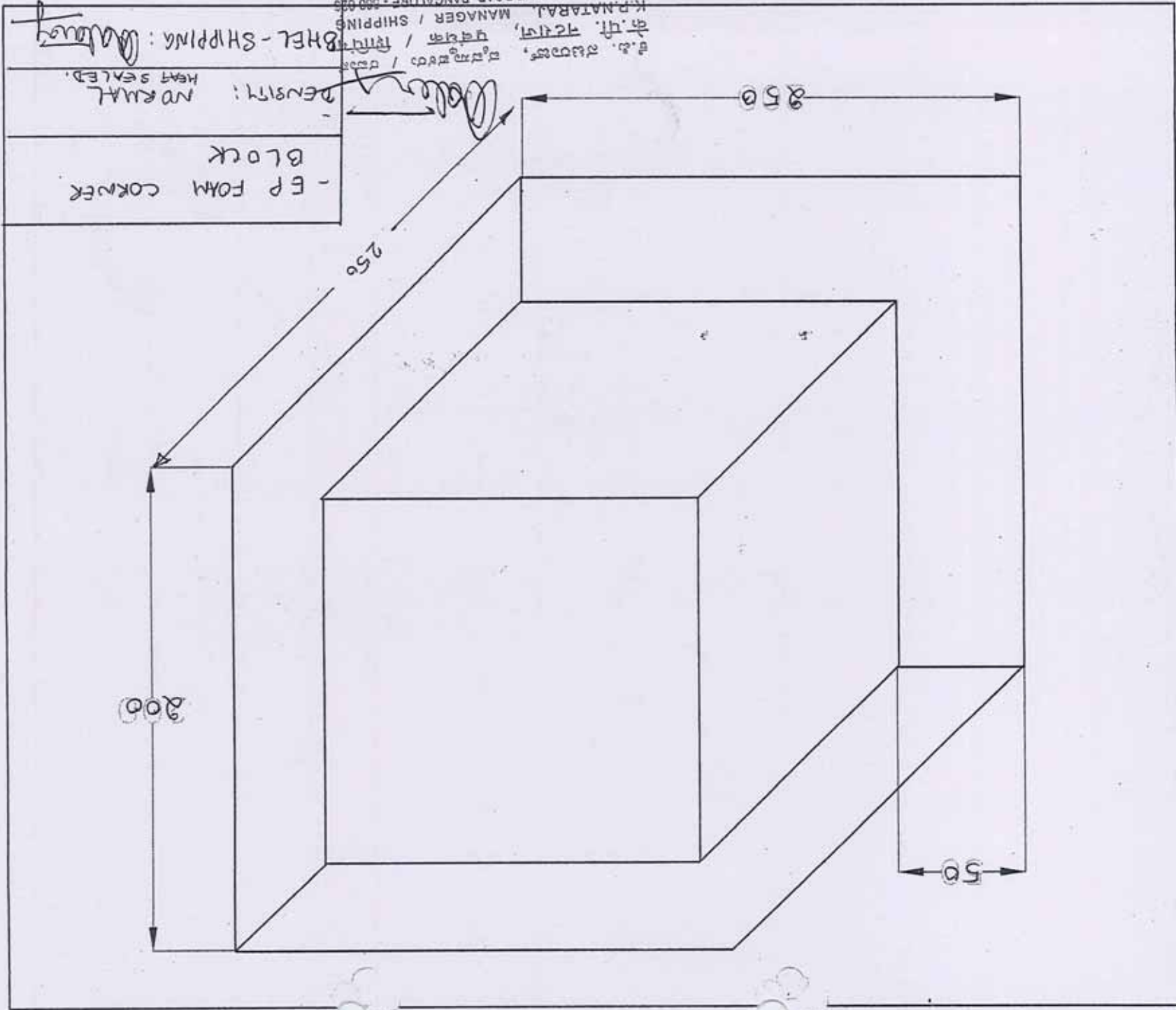

RP800 Thyristor Module Shipping Documents

ML1369SH16600110

dt: 22 Dec 2017

Sl.No.	Description	Document No.	Rev.No.
1	Packing Instructions RP800 Thyristor Module	GI1369SH16600105	3
2	Packing Box Drawing	36722600805	3
3	Plastic Cover	1JNL100033-741	2
4	Dimension Drawing, Thyristor Module	1JNL100107-585	2
5	Packing Element above Heat Sink	1JNL100109-276	0
6	Packing Element between Capacitors	1JNL100109-307	0
7	Packing Element below Capacitors	1JNL100109-309	0
8	Packing Element below Heat Sinks	1JNL100109-275	1
9	Packing Element Frame Corner	1JNL100109-267	2
10	Packing Element Frame Corner	1JNL100109-273	1
11	Packing Element Bus bar	1JNL100033-735	1
12	Dessicant bags	2969138	6
13	Humidity Indicator	2969137-1	2
14	Check During Packing	2098042E-41	3
15	BOM for packing Thyristor modules	BOM	

Prepared by

N Subramanian / Rajiv C G

Checked and Approved by

Dr. Ghamandi Lal

HVDC

±800 kV, 6000MW HVDC Raigarh – Pugalur Terminals		Document Number GI1369SH16600105	No of Pages 6
		Ref ABB doc 1JNL100501-787	No of Attached Pages
Prepared Rajiv C G / N Subramanian 04-10-2017		Title Packing Procedures for Thyristor Modules	Reg./Class no. NEA-
Approved Ghamandi Lal 04-10-2017	Resp Dept HVDC		

This document is issued by means of a computerized system. The digitally stored original is electronically approved. The approved document has a name and date entered in the approved-field. A manual signature is not required.

Summary

**PACKING PROCEDURES FOR
THYRISTOR MODULES**

03	Marking colours Changed.	Rajiv C G	23-02-2018	Ghamandi Lal 23-02-18
02	Shipping feedback incorporated	Rajiv C G	22-12-2017	Ghamandi Lal 22-12-17
01	Figure 3 modified	Rajiv C G	12-12-2017	Ghamandi Lal 12-12-17
Rev ind	Revision text	Prepared	Approved	



SAFETY INFORMATION

The packing procedures for thyristor modules present potentially unsafe conditions, including, but not limited to the following:

- Moving machinery
- Heavy components
- Slip, stumble or fall
- Hot equipment

Specialized procedures and instructions are required and must be adhered to when working on such apparatus. Failure to follow the instruction could result in severe personal injury, death and/or product or property damage.

Additionally, all applicable safety procedures such as regional or local safety rules and regulations, safe working practices, and good judgment must be used by the personnel when installing and operating such equipment.

Safety, as defined in this instruction, involves two conditions:

Personal injury or death

Product or property damage

Safety notations are intended to alert personnel to possible personal injury, death or property damage. They have been inserted in the instructional text prior to the step in which the condition is cited.

The safety conditions are headed by one of the three hazard intensity levels, which are defined as follows:

DANGER

Immediate hazard, which will result in severe personal injury, death or property damage.

WARNING

Hazard or unsafe practice, which could result in severe personal injury, death or property damage.

CAUTION: Hazard or unsafe practice that could result in minor personal injury or property damage.

1 Packing material

1 pc	Box	36722600805	Bolted type plywood box Shown in Fig 1a & 1b
1 pc	Plastic cover	1JNL100033-741	
1 pc	Thyristor module		Fig 2
1pc	Packing element	1JNL100109-276	Fig 2 Pos 3 above heat sinks
1pc	Packing element	1JNL100109-307	Fig 2 Pos 7 between capacitors
1pc	Packing element	1JNL100109-309	Fig 2 Pos 8 below capacitors
9pcs	Packing elements	1JNL100109-275	Fig 2 Pos 2 below heat sinks
2pcs	Packing element	1JNL100109-267	Fig 2 Pos 4 frame corner
2pcs	Packing element	1JNL100109-273	Fig 2 Pos 5 frame corner
2pcs	Packing element	1JNL100033-735	Fig 2 Pos 6 bus bar
2pc	Packing element	Figure 3	Fig 2 Pos 9 between box and yoke
1pc	Packing element	Figure 4	Fig 2 Pos 10 below Thyristor module
10pcs	Desiccant bags	2969138-4	2.5 kg Distributed in the box
1pc	Humidity Indicator	2969137-1	Placed inside bag (readable)

NOTE: The packing elements shall be made of either EPP as per the above drawings or as manufactured in India and used for packing. Bolted type box shall be generally as per EDN Standard ED0490092 using 12mm ply on the sides and top and 18mm ply in the bottom and 50mm x 50mm wooden battens. Plywood to be of MR. IS.303 grade, battens and runners to be of silver oak wood or pine wood.

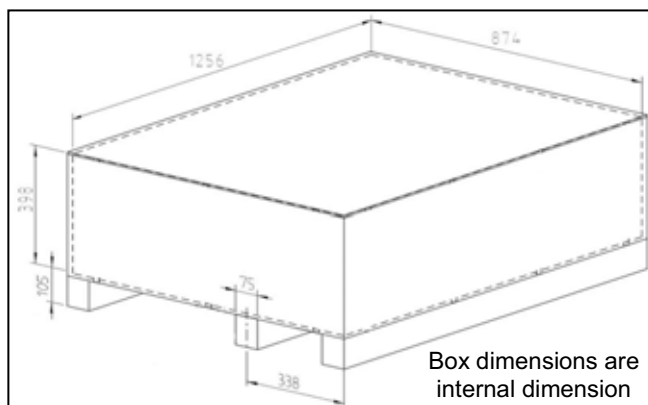

Figure-1a: Box for packing Thyristor Modules



Figure-1b: Typical Bolted type construction of Plywood Box.

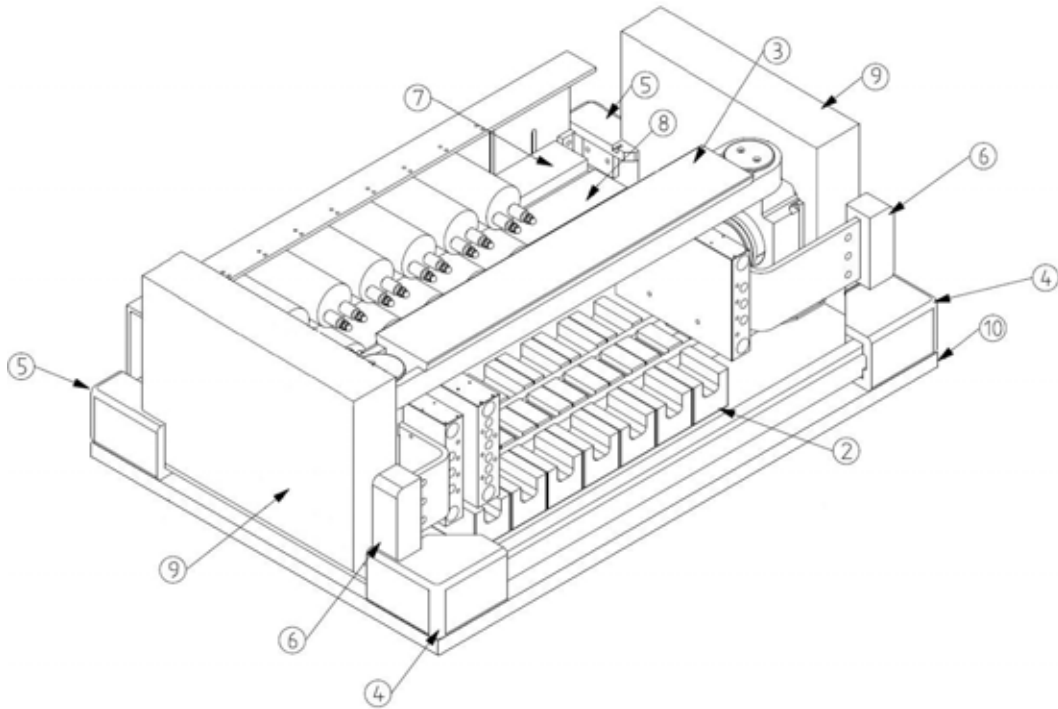

Figure 2: Packaging of the Thyristor Module

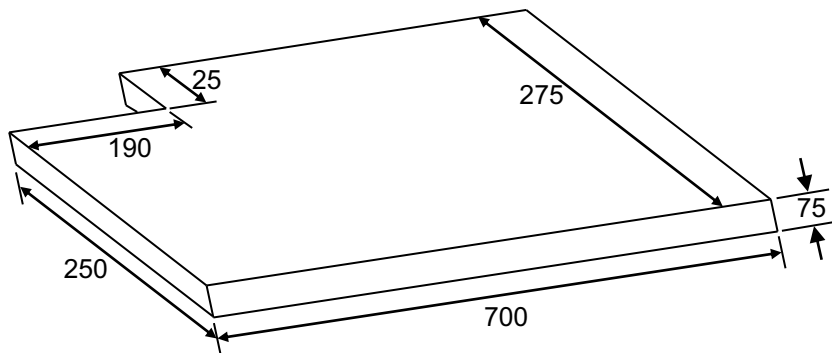

Figure 3: Packing Element between Box and Yoke in Thyristor Module Packing

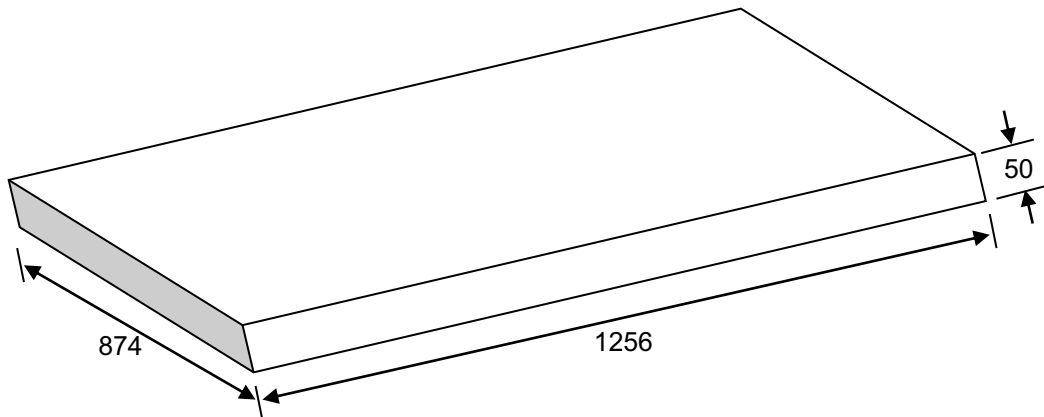

Figure 4: Cushion below the Thyristor Module

Assembly packing

1. Assemble the box
2. Install the plastic bag in the box
3. Place the bottom cushion (Figure 4) in the plastic bag

WARNING

4. Collect the thyristor module from the storage rack

WARNING

5. Lift the thyristor module with the four slings with hooks after inserting the hooks from the outside.
6. Mount all packing parts except pos 9 (Figure 3) and pos 10 (Figure 4) and pos 6 1JNL100033-735.

2 Packing of thyristor module

WARNING

7. Lower the thyristor module into the bag in the box. Pull up the sides of the bag before lowering the thyristor module all the way to the bottom.
8. Install pos 9 (Figure 3) and pos 6 1JNL100033-735 two pieces.
9. Place the desiccant bags, 2.5kg distributed in the box over the thyristor module
10. Place the humidity indicator readable inside the plastic bag

CAUTION

11. Seal the opening of the bag (with suitable heater) but leave a small opening for the vacuum suction.
12. Vacuum the bag and check that it is not leaking.

CAUTION

13. Seal the last opening (with suitable heater)
14. Fold the bag and put on the lid and fasten it
15. Mark the box with project name, station and thyristor module number.

3 Transport by road

Thyristor Modules thus packed in bolted plywood boxes may be directly loaded on trucks, anchored in place with ropes and transported to destination sites. During transport the maximum number of packed Thyristor modules that can be stacked is **three (3)**.

4 MARKING OF CASES

Mark on the two adjacent sides of each package. The marking shall be weather resistant and shall be inalterable and indelible (ex.: UV rays, water, moisture, heat, cold, friction, etc.).

The size of marking label shall be at least 29 x 21 cm.

Mark the following on the two adjacent sides of each package.

– WBS No.	CE/1369-SHx-66-xx
– Storage Requirement	Indoor
– Content Description	Thyristor Module
– Net weight	In kilograms
– Gross weight	In kilograms
– Dimension	L x W x H in centimetres
– Case No.	As per BHEL standard
– Project Name	RP800 – HVDC
– Consignee	As per sale order

Colour Marking

In addition to the above marking all cases shall have colour marking of two adjacent upper corners.

Raigarh site = Yellow

Pugalur site = Blue

Placing of marking

Each case shall have marking on two adjacent sides and one marking inside the box.

Marking of case

In addition to the above marking, the case itself shall be indelibly marked with the same case number as stated on the template on all four sides. Figures **must** be at least 50 mm high.

According to the characteristics of the Contract Equipment, packages shall be marked legibly with words "Handle with Care", "Right side Up", "Keep Dry",

STORAGE REQUIREMENTS

The storage level of the packages is **indoor**

Packed thyristor modules have to be **stored indoor** both at the factory and at site.

For storage the maximum number of packed Thyristor modules that can be stacked is **five (5)**.

3 672 26 00805
DRAWING NO.

COPYRIGHT AND CONFIDENTIAL
 The information on this document is the property of Bharat Heavy Electricals Limited.
 It must not be used directly or indirectly in any way detrimental to the interest of the Company

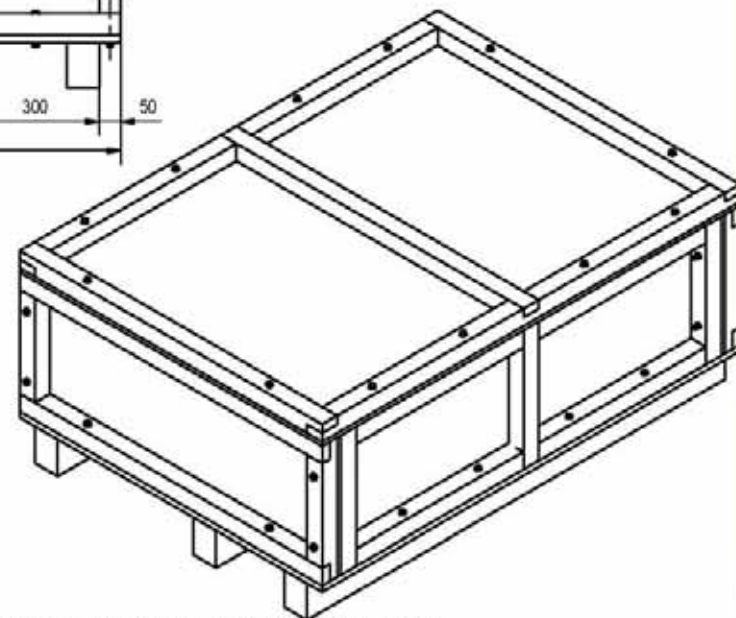
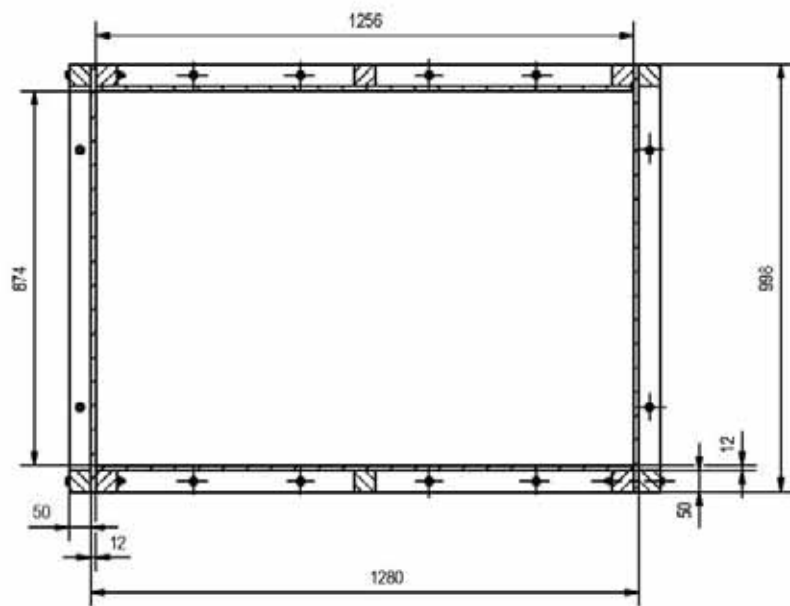
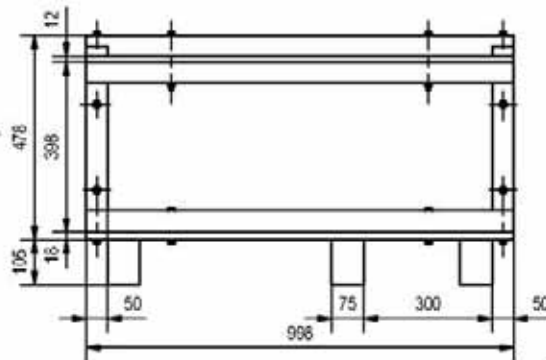
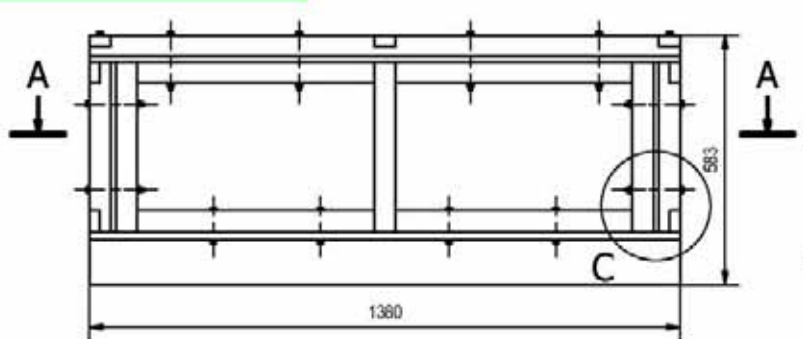

NOTE

- 12MM PLYWOOD SHALL BE USED FOR SIDES AND TOP COVER OF GRADE MR. IS. 303
- 18MM PLYWOOD SHALL BE USED FOR BOTTOM OF GRADE MR. IS. 303
- 50MMx30MM WOODEN BATTENS SHALL BE USED ON THE EDGES & MIDDLE
- SILVER OAK WOOD OR PINE WOOD SHALL BE USED FOR BATTENS AND THREE BOTTOM RUNNERS
- M8 ZINC PLATED BOLTS SHALL BE USED FOR FASTENING (100MM - 12NOS FOR BOTTOM, 150MM - 20NOS FOR THE REST)
- M8 ZINC PLATED WASHERS (2 PER BOLT) AND M8 ZINC PLATED GI NUT (1 PER BOLT) SHALL BE USED
- ALL JOINTS SHALL BE LAP JOINT
- WATER-PROOF BITUMEN COATED SHEET AS PER ED0490092 SHALL BE USED UNDER TOP COVER
- ALL LABELS & STICKERS SHALL BE FIXED BY STAPLES FOR WOOD

TYPE OF PRODUCT OR
NAME OF CUSTOMER/PROJECT

BHARAT HEAVY ELECTRICALS LIMITED. ELECTRONICS DIVISION, BANGALORE	DRN	NAME	SIGN.	DATE	No. OF VAR
	CKD	D D		27.02.13	
	APPD	D D		27.02.13	

DEPT. HVDC	FOR UNSPECIFIED-TOLERANCES REFER ED 0230499	SCALE 1:12.5	WEIGHT/Kg	REF. TO ASSY. DRG.	ITEM NO.	No. OF
------------	---	--------------	-----------	--------------------	----------	--------

TITLE	DRAWING NO.	REV.
PLYWOOD BOX FOR PACKING (THYRISTOR MODULE)	3 672 26 00805	03
SHEET NO. 01	NO. OF SHEETS 01	

REV. 03	DATE 22.12.17	ALTERED CHECKED APPROVED	NS CGR CGR	REV. 02	DATE 13.12.13	ALTERED CHECKED APPROVED	MGMalagi D D D D	REV. 01	DATE 08.10.13	ALTERED CHECKED APPROVED	MGMalagi D D D D
REVISED & REDRAWN AS PER SHIPPING FEEDBACK				DETAIL 'C' SHOWN AND BOLTS ON TOP INCREASED				REVISED & REDRAWN AS PER SHIPPING FEEDBACK			

REF. DRG. NO. 36722600805
 SIGN & DATE
 INVENTORY NO.

Material: Polyethene film
 Material: Polyetenfolie BORSTAR 6592 T=0,20

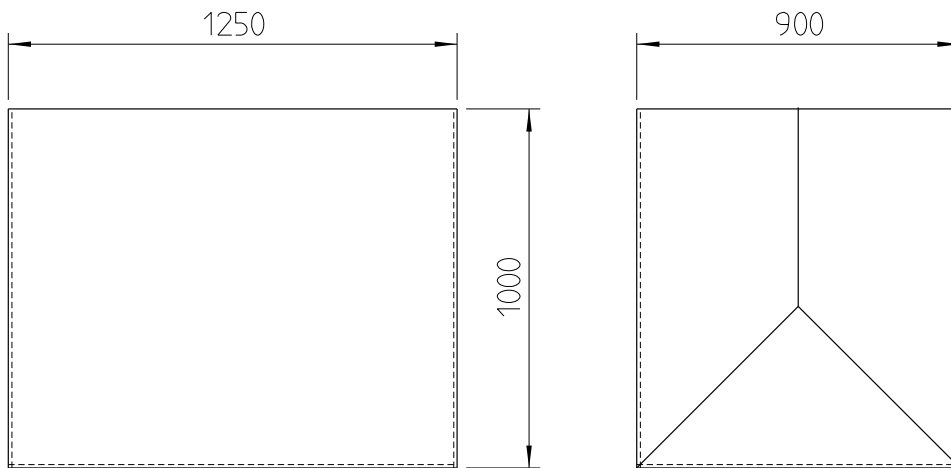

We reserve all rights in this document and in the information contained therein. Reproduction, use or disclosure to third parties without express authority is strictly forbidden. © ABB Power Systems (SE)

This document is issued by means of a computerized system. The digitally stored original is electronically approved. A manual signature is not required.

Inspection as shown in
 Kontroll enligt 2098 069-3

2 Material ch. T was 0,25 00.35

Rev Ind	Revision	Appd	Year	Week

Qual. control K-O Eriksson		Project name	
Prepared 2000-03-02 S Dahlgren		3G	
Approved Björn Sandin		Item designation	
Component Drawing			
Plastic Cover		Resp dept POW/PTK	Rev ind 2
		Language en	
Document number			
1JNL 100 033-741			
		Sheet/af 1/1	

(A4)

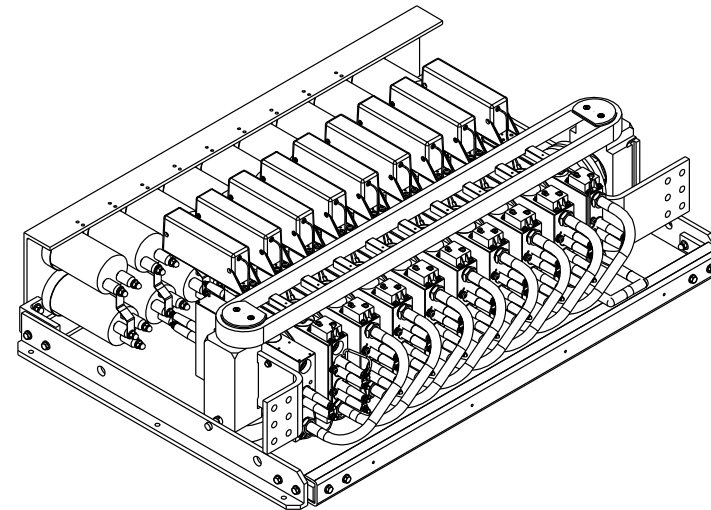
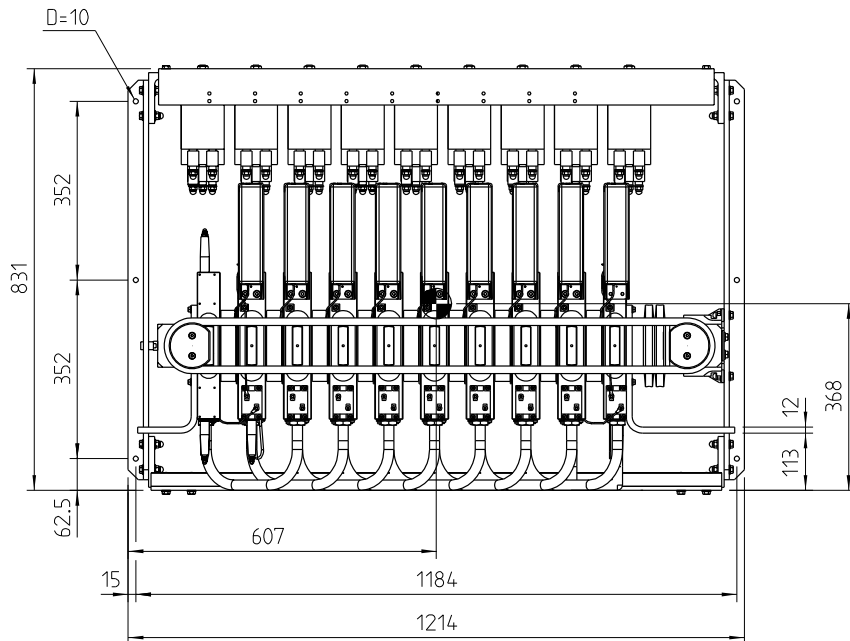
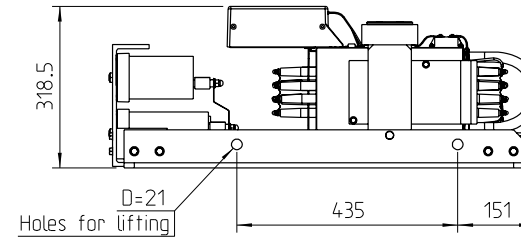
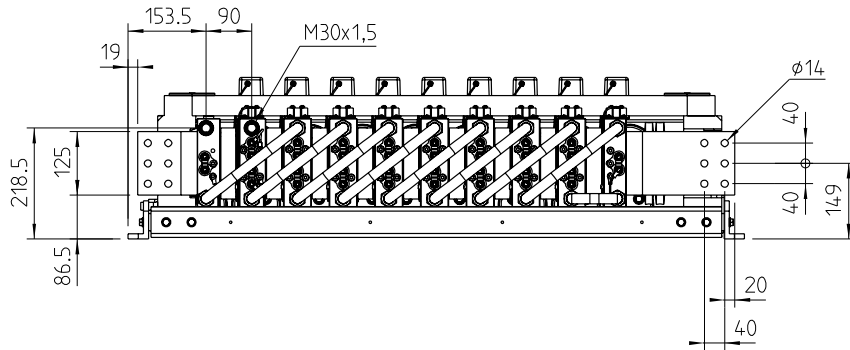

We reserve all rights in this document and in the information contained therein. Reproduction, use or disclosure to third parties without the express authority of ABB is prohibited. © ABB AB 2005

This document is issued by means of a computerized system. The digitally signed original is electronically approved.

Centre of gravity Tyngdpunkt Mass: 205 kg

Checked	Project name		
Prepared 2005-10-12	HVDC Classic		
Approved	Item designation		
Dimension Drawing	Resp dept TVM	Rev ind 2	Language en
Thyristor Module	Document number		☑
Low Current	1JNL 100 107-585		
ABB AB HVDC		Sheet of 1/1	

2 Washer clamping string revised.

13.41

Rev ind Revision Appd Year Week

IA3)

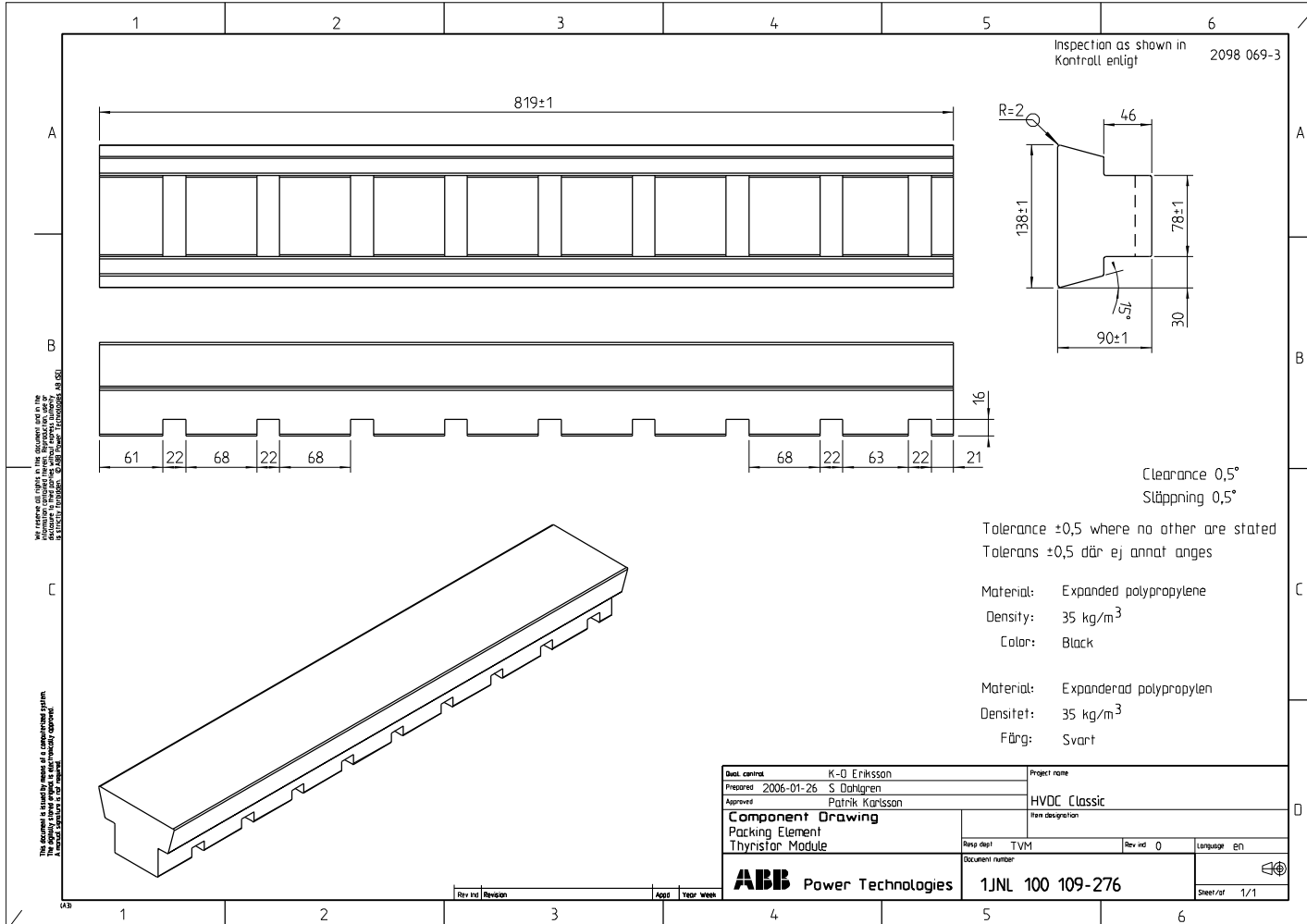

Inspection as shown in
Kontroll enligt 2098 069-3

819±1

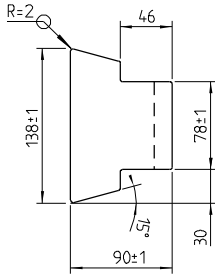

61 22 68 22 68 68 22 63 22 21

Clearance 0,5°
Släppning 0,5°

Tolerance ±0,5 where no other are stated
Tolerans ±0,5 där ej annat anges

Material: Expanded polypropylene
Density: 35 kg/m³
Color: Black

Material: Expanderad polypropylen
Densitet: 35 kg/m³
Färg: Svart

No changes allowed after the issuance of the drawing.
 The drawing is ready for use as a manufacturing document.
 A change requires a new drawing.

Desig. control	K-O Eriksson	Project name	
Prepared	2006-01-26 S Dahlgren		
Approved	Patrik Karlsson	HVDC Classic	
Component Drawing		Item designation	
Packing Element		Resp. dept	TVM
Thyristor Module		Rev. ind	0
		Language	en
Document number		1JNL 100 109-276	
ABB Power Technologies		Sheet / of 1 / 1	

Rev no Revision Appr Year week

Inspection as shown in
Kontroll enligt 2098 069-3

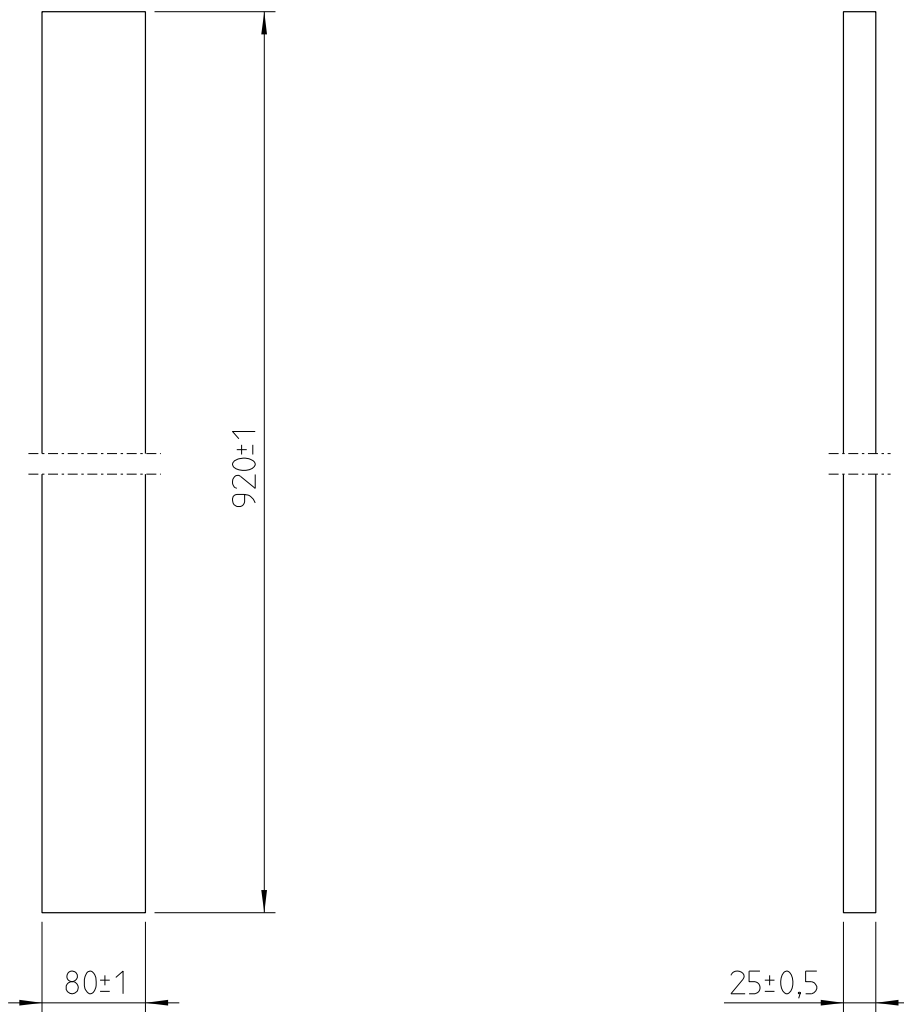



We reserve all rights in this document and in the information contained therein. Reproduction, use or disclosure to third parties without express authority is strictly forbidden. © ABB Power Technologies AB (SE)

Material: Expanded polypropylene
Density: 35 kg/m³
Color: Black

Material: Expanderad polypropylen
Densitet: 35 kg/m³
Färg: Svart

This document is issued by means of a computerized system. The digitally stored original is electronically approved. A manual signature is not required.

Rev Ind	Revision	Appd	Year	Week		
Qual. control		K-O Eriksson			Project name	
Prepared		2006-01-26 S Dahlgren			HVDC Classic	
Approved		Patrik Karlsson			Item designation	
Component Drawing				Resp dept TVM		
Packing Element				Rev ind 0		Language en
Thyristor Module				Document number		
 Power Technologies				1JNL 100 109-307		

Inspection as shown in
Kontroll enligt 2098 069-3

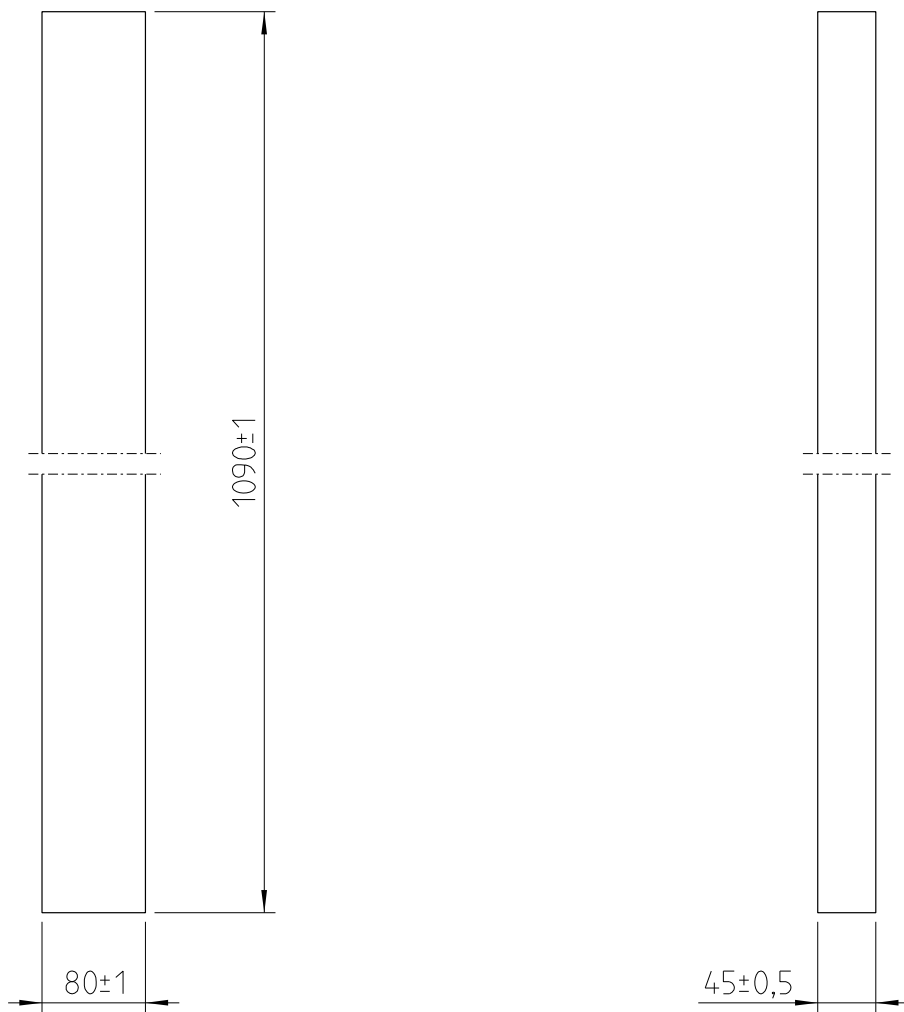



We reserve all rights in this document and in the information contained therein. Reproduction, use or disclosure to third parties without express authority is strictly forbidden. © ABB Power Technologies AB (SE)

Material: Expanded polypropylene
Density: 35 kg/m³
Color: Black

Material: Expanderad polypropylen
Densitet: 35 kg/m³
Färg: Svart

This document is issued by means of a computerized system. The digitally stored original is electronically approved. A manual signature is not required.

Rev Ind	Revision	Appd	Year	Week		
Qual. control		K-O Eriksson			Project name	
Prepared		2006-01-26 S Dahlgren			HVDC Classic	
Approved		Patrik Karlsson			Item designation	
Component Drawing				Resp dept TVM		
Packing Element				Rev ind 0		Language en
Thyristor Module				Document number		
 Power Technologies				1JNL 100 109-309		

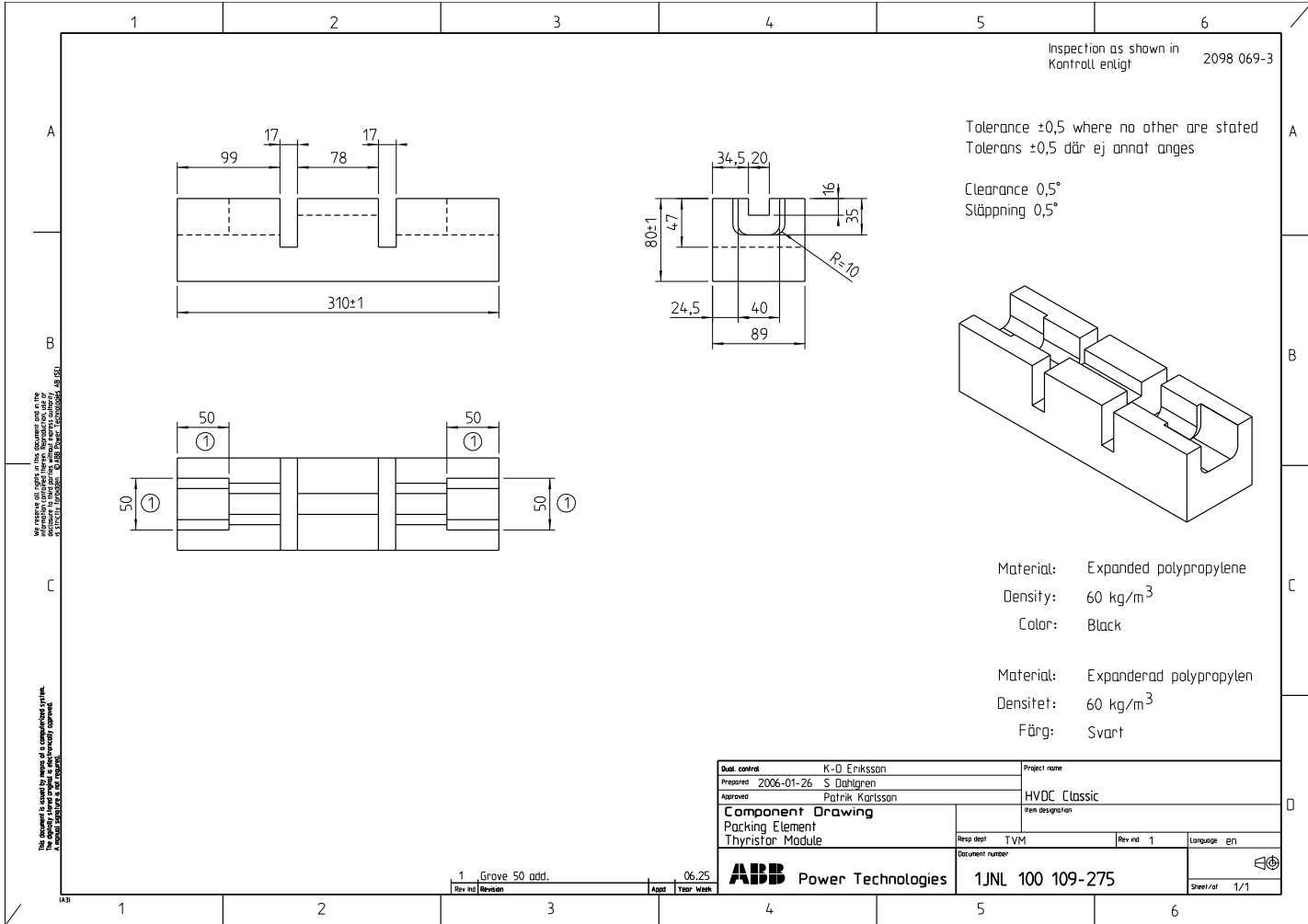

Inspection as shown in
Kontrall enligt 2098 069-3

Tolerance $\pm 0,5$ where no other are stated
Tolerans $\pm 0,5$ där ej annat anges

Clearance $0,5^\circ$
Släppning $0,5^\circ$

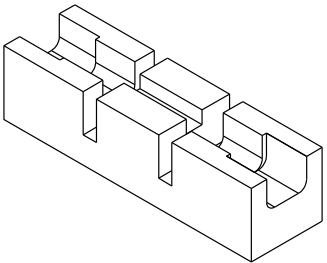

Material: Expanded polypropylene
Density: 60 kg/m^3
Color: Black

Material: Expanderad polypropylen
Densitet: 60 kg/m^3
Färg: Svart

No drawing shall copy, or be reproduced, or be used for any other purpose, without the written consent of ABB Power Technologies AB. SEI

The drawing is made by means of a computerized system. The accuracy is guaranteed within the limits of the system. A GENERAL WARNING IS HEREBY ADVISED.

Draft control: K-O Eriksson Prepared: 2006-01-26 S Dahlgren Approved: Patrik Karlsson	Project name: HVDC Classic Item designation:
Component Drawing Packing Element Thyristor Module	
Resp dept: TVM	Rev ind: 1
Language: EN	
Document number: 1JNL 100 109-275	
Sheet / of: 1 / 1	

1	Grave 50 add.	06.25
Rev no	Revision	Appr Year week

1 2 3 4 5 6

Inspection as shown in
Kontroll enligt 2098 069-3

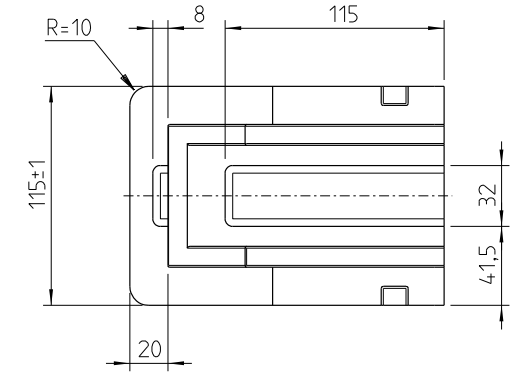
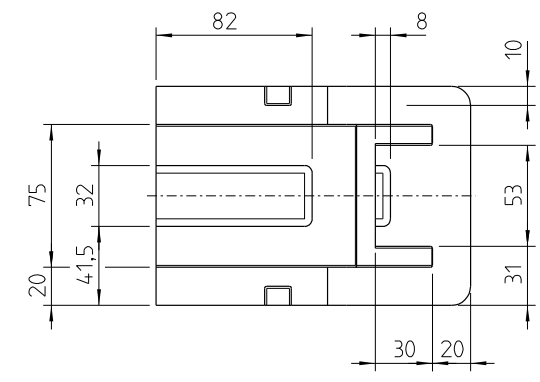

Tolerance $\pm 0,5$ where no other are stated.
Tolerans $\pm 0,5$ där ej annat anges.

Clearance 0,5°
Stäppning 0,5°

A

B

C

We reserve all rights in the document and in the information contained therein. Reproduction, use or disclosure to third parties without express authority is strictly prohibited. © ABB Power Technologies AB (SE)

This document is issued by means of a computerized system. The original signed original is electronically approved. A manual signature is not required.

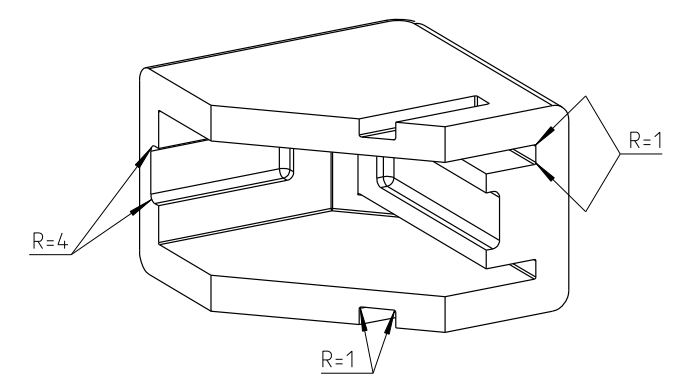
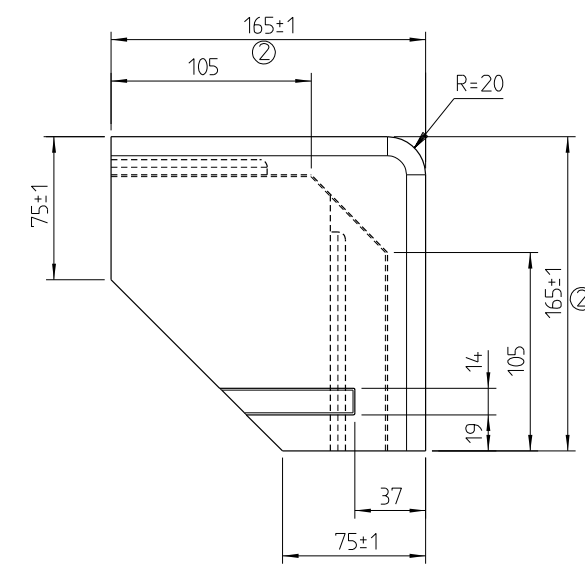

Material: Expanded polypropylene
Density: 60 kg/m³
Color: Black
Material: Expanderad polypropylen
Densitet: 60 kg/m³
Färg: Svart

A

B

C

D

2	Dim was 175.	06.25
Rev Ind	Revision	Appd Year Week

Qual. control	K-O Eriksson	Project name	
Prepared	2006-01-26 S Dahlgren		
Approved	Patrik Karlsson	HVDC Classic	
Component Drawing		Item designation	
Packing Element		Resp dept	TVM
Thyristor Module		Rev ind	2
		Language	en
Document number		E1	
ABB Power Technologies		1JNL 100 109-267	
		Sheet/of 1/1	

IA31

1 2 3 4 5 6

Inspection as shown in
Kontroll enligt 2098 069-3

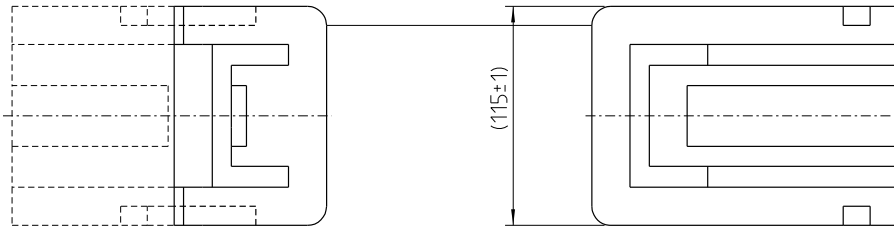

Tolerance $\pm 0,5$ where no other are stated.
Tolerans $\pm 0,5$ där ej annat anges.

Clearance $0,5^\circ$
Stäppning $0,5^\circ$

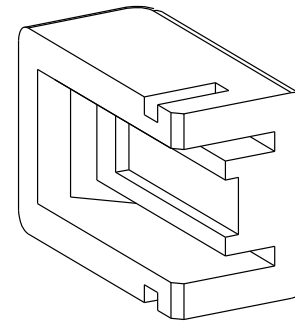
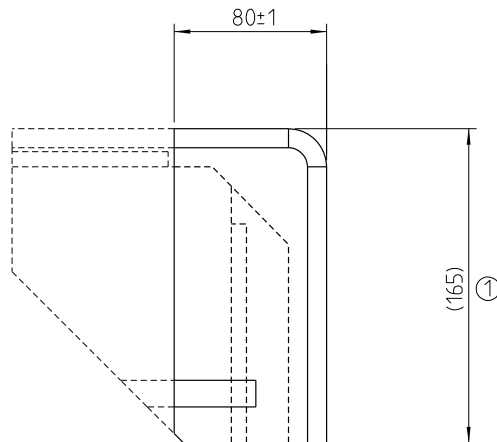

Material: Expanded polypropylene
Density: 60 kg/m^3
Color: Black

Material: Expanderad polypropylen
Densitet: 60 kg/m^3
Färg: Svart

We reserve all rights in the document and in the information contained therein. Reproduction, use or disclosure to third parties without express authority is strictly prohibited. © 2006 ABB Power Technologies AB (SE)

This document is issued by means of a computerized system. The digitally signed content is electronically approved. A manual signature is not required.

-	-	1JNL 100 109-267			Packing Element	
Item No.	Qty	Article No.	Material, type, etc	Dimensions	Name of item	Note
Dual control		K-O Eriksson		Project name		
Prepared		2006-01-26 S Dahlgren		HVDC Classic		
Approved		Patrik Karlsson		Item designation		
Component Drawing			Thyristor Module			
Packing Element			Resp dept TVM			
Thyristor Module			Rev ind 1		Language en	
ABB Power Technologies			Document number		1JNL 100 109-273	
					Sheet/of 1/1	

1 Dim was (175).

06.25

Rev Ind Revision Appd Year Week



We reserve all rights in this document and in the information contained herein. Reproduction, use or disclosure to third parties without express authority is strictly forbidden. © ABB Power Systems (SE)

This document is issued by means of a computerized system. The digitally stored original is electronically approved. A manual signature is not required.

Inspection as shown in
Kontroll enligt

2098 069-3

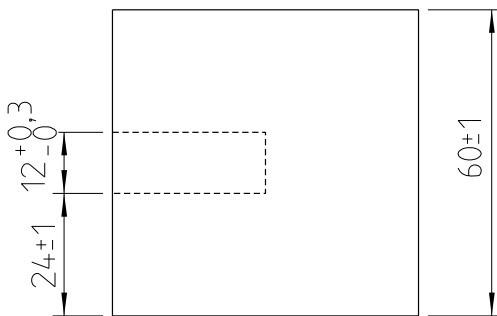
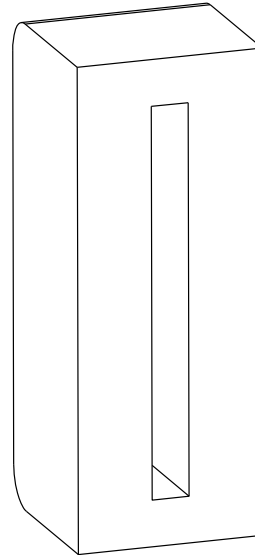
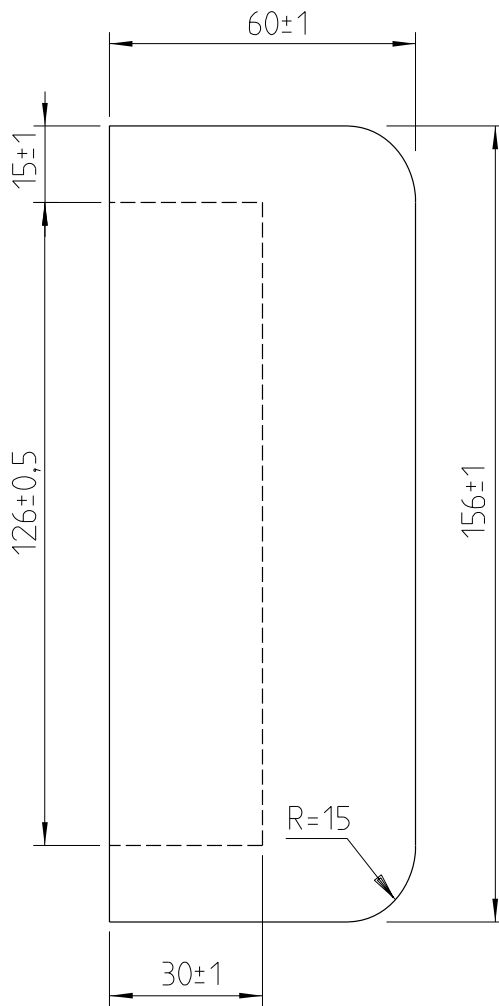

Clearance 0,5°
Släppning 0,5°

Material: Expanded polypropylene
Density: 60 kg/m³
Color: Black

Material: Expanderad polypropylen
Densitet: 60 kg/m³
Färg: Svart

1 Redrawn		00.20	
Rev Ind	Revision	Appd	Year Week
Qual. control Dan Elofsson		Project name	
Prepared 2000-03-02 S Dahlgren		3G	
Approved Björn Sandin		Item designation	
Component Drawing			
Packing Element		Resp dept POW/PTK	Rev ind 1
		Language en	
Document number			
ABB ABB Power Systems		1JNL 100 033-735	
		Sheet/af 1/1	

Sub No.	Dimensions			Content Gram	Technical requirements according to DIN
	L	W	H		
-1	110	85	7	30	1- DIN 55 473-B
-2	130	100	10	63	2- DIN 55 473-B
-3	180	110	20	125	4- DIN 55 473-B
-4	200	130	30	250	8- DIN 55 473-B
-5	220	170	40	500	16- DIN 55 473-B
-6	250	200	50	1000	32- DIN 55 473-B
-7	80	60	5	10	1/3- DIN 55 473-B

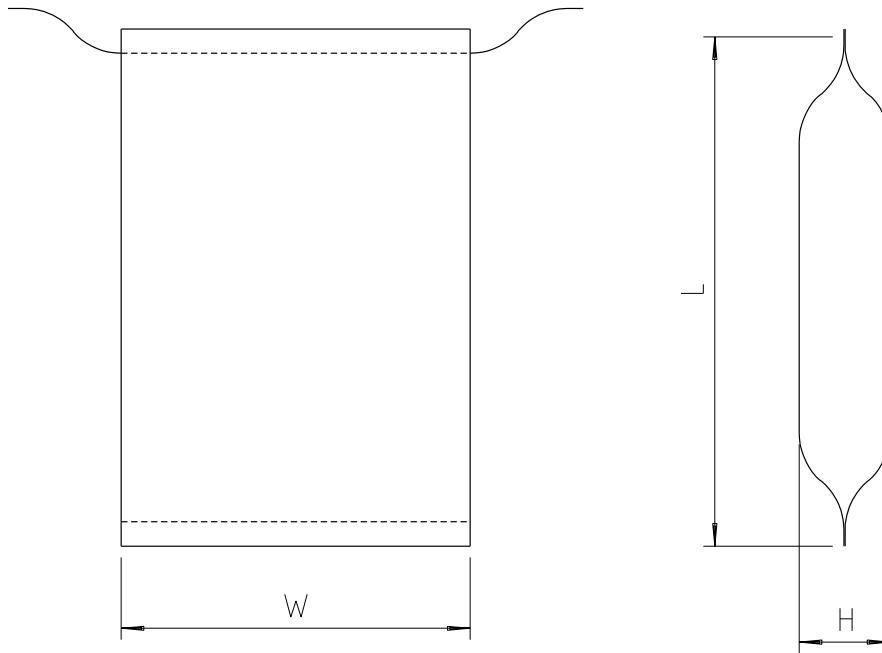

We reserve all rights in this document and in the information contained therein. Reproduction, use or disclosure to third parties without express authority is strictly forbidden. © ABB Power Technologies AB (SE)

This document is issued by means of a computerized system. The digitally stored original is electronically approved. A manual signature is not required.

6	Updated	04.46	Inspection as shown in Kontroll enligt		2098 069-3
Rev Ind	Revision	Appd	Year	Week	
Qual. control		K-O Eriksson		Project name	
Prepared		1975-04-05 S Dahlgren			
Approved		B Jacobson		Item designation	
Component Drawing			Bag with Desiccants		
Påse med torkmedel			Resp dept	PTPS/DC/TVM	Rev ind 6
			Language	en	
Document number			2969 138		
ABB Power Technologies					
			Sheet/af	1/1	

We reserve all rights in this document and in the information contained therein. Reproduction, use or disclosure to third parties without express authority is strictly forbidden. © ABB AB (SE)

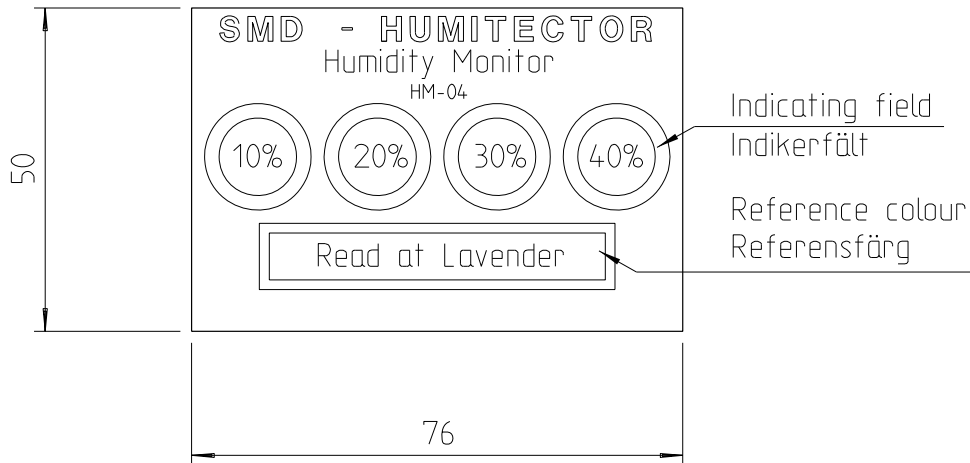

Material: Paper adhesive
 Material: Papper självhäftande

This document is issued by means of a computerized system. The digitally stored original is electronically approved. A manual signature is not required.

2	Updated		12.19		
Rev Ind	Revision		Appd	Year Week	
Checked	K-O Eriksson			Project name	
Prepared	1975-04-05 S Dahlgren				
Approved	B Jacobsson			Item designation	
Component Drawing					
Humidity Indicator					
fuktighetsindikator				Resp dept	TVM
				Rev ind	2
				Language	en
ABB AB				Document number	
HVDC				2969 137-1	
					
				Sheet/af 1/1	

(A4)

1. SCOPE

This Instruction describes checking during packing of Thyristor and Reactor modules.

2. INSPECTOR

The checks shall be carried out by the operator.

3. VISUAL INSPECTION

Prior to packing, the goods shall be inspected with regard to damages to the lacquering and damaged or missing transport protections.

4. MARKING OF MATERIAL

A check shall be made, that all the parts are marked. The part shall be marked with the manufacturing number on the outside.

5. CHECK OF PACKING

A check shall be carried out to assure, that the packing materials are not wounded.

6. PACKAGE

The package shall be properly sealed.
The plastic covers must not be damaged by sharp edges and corners.
Drying agents shall be used in specified quantities.

7. SIGNING

After a check has been carried out, the inspection card shall be signed.

We reserve all rights in this document and in the information contained herein. Reproduction, use or disclosure to third parties without express authority is strictly forbidden.
© ABB Power Systems (SE)

This document is issued by means of a computerized system. The digitally stored original is electronically approved. The approved document has a name and date entered in the "approved"-field. A manual signature is not required.

03	Point 2: Random sample checks omitted.		Björn Sandin 2000-06-08
Rev	Revision	Approved	
Based on		Project name	
Prepared	P-O Hedblad 86-10-22	General	
Approved	Björn Sandin 2000-06-08!		
Title		Instruction	Item designation
CHECK DURING PACKING		Resp dept PTK	Language en
 ABB Power Systems		Document number	
		2098042E-41 Rev. 03	Sheet/of 1/1

Bill of Materials for Packing Thyristor Modules

Sl. No.	Description	Drawing	Qty/module
1	Packing Box - bolted type plywood box with plywood of grade MR. IS. 303	36722600805	1
2	Plastic Cover (polyethene of thickness 200micron)	1JNL100033-741	1
3	Packing element above heat sinks (Expanded polypropylene of density 35kg/m ³)	1JNL100109-276	1
4	Packing element between capacitors (Expanded polypropylene of density 35kg/m ³)	1JNL100109-307	1
5	Packing element below capacitors (Expanded polypropylene of density 35kg/m ³)	1JNL100109-309	1
6	Packing element below heat sinks (Expanded polypropylene of density 35kg/m ³)	1JNL100109-275	9
7	Packing element for frame corner (Expanded polypropylene of density 35kg/m ³)	1JNL100109-267	2
8	Packing element for frame corner (Expanded polypropylene of density 35kg/m ³)	1JNL100109-273	2
9	Packing element for bus bar (Expanded polypropylene of density 35kg/m ³)	1JNL100109-735	2
10	Packing element between box and yoke (Expanded polypropylene of density 35kg/m ³)	Fig 3 in GI1369SH16600105	2
11	Packing element below Thyristor module (Expanded polypropylene of density 35kg/m ³)	Fig 4 in GI1369SH16600105	1
12	Desiccant bags (Unisorb silca gel crystals or equivalent) (250gms each - 2.5 kg to be distributed in the box)	2969138-4	10
13	Humidity indicator to be provided by BHEL		
14	Zinc plated Bolts - M8 length 100mm		12
15	Zinc plated Bolts - M8 length 150mm		20
16	Zinc plated Nuts - M8		32
17	Zinc plated Plain Washers - M8		64
18	Packing note holder as per ED0490092		1
19	Name plate as per ED0490092		1
20	Address Label as per ED0490092		2
21	BHEL Monogram as per ED0490092		1
22	Fragile Mark as per ED0490092		1
23	Chain Mark as per ED0490092		4

Note:

1. All labels and stickers should be fixed by staples for wood.
2. Appropriate equipment for creating vacuum and heat sealing to be arranged by the vendor.
3. Along with this BOM the drawings mentioned above, packing instructions GI1369SH16600105 and EDN standard ED0490092 shall be referred.