

LIST OF TENDER DOCUMENTS HOSTED FOR 54AA MAIN ARC-2019-20			
Enquiry No.658014E			Dt.16.09.2019
S.No	Section	Description	Pages
TENDER SECTIONS			
1	Section I	Notice Inviting Tender	01 to 01
2	Section II	Techno Commercial Terms and Conditions	01 to 23
3	Section III	Technical Description for RS 54AA	01 to 03
4	Section IIID	List of Extra Rate Schedules for reference purpose	01 TO 02
5	Section IV	General Terms & Conditions	01 to 25
6	Section-V	Drawing Numbers for RS	2 Drawings
7	Section-VI	Flow Chart for MAS	01
8	Section-VII	Not Applicable	N.A
9	Section-VIII	List of Approved Vendors for (A) procurement of Welding Consumables, Paints, Penetrant Chemicals and (B) conducting of NDT, Galvanising and Heat Treatment	01 to 46
10	Section-IX	List of Standard QWI	01 to 04
11	Section-X	List of Quality Documents	12 Docs
12	Section-XI	Not Applicable	----
13	Section-XII	Bank Guarantee Format.	01 to 06
TENDER ANNEXURES			
14	Annexure-A	Check List for Cover-I	01
15	Annexure-B	Check List for Cover-II	01
16	Annexure-C	Technical Bid Format	01
17	Annexure-D	Price Bid Format	01
18	Annexure-E	Standard Commercial Terms and Conditions	01
19	Annexure-F	Eligibility Criteria - Manufacturing Facilities Available for 54AA Fabrication Annexure-FH with Firm (Format will be used for Vendor Evaluation)	01 TO 02
20	Annexure-G	Certification FOR MSME	01
21	Annexure-H	Integrity Pact	01 to 06
22	Annexure-I	Affidavit	01
23	Annexure-J	Sample copy of Power of Attorney	01 to 02
24	Annexure-K	Vendor Registration Forms	01 to 24

The above documents and sketches are to be downloaded from the website

**BHARAT HEAVY ELECTRICALS LIMITED**

(A Government of India Undertaking)

பாரதமிகுமின் நிறுவனம்

BOILER AUXILIARIES PLANT, Indira Gandhi Industrial Complex,
RANIPET- 632 406 (Tamil Nadu)Ph: 04172-284030,
284158, 241170Email:
bsmanian@bhel.in
ssvasan@bhel.in**SECTION – I****NOTICE INVITING TENDER (NIT)****(This is only a request for an offer and not a Contract)**

Tenders are hereby invited from experienced Contractors through **reverse auction** to finalise the Rates for entering into Annual Rate Contract for the year 2019-20 for Complete Manufacture of casing walls Hopper Walls, Roof Panels , Gable Top/middle/bottom ,insulator pannels etc from raw materials/components supplied from BHEL. Vendor scope includes collection of raw materials from BHEL (single/multiple) and delivery of finished goods to BHEL shipping . All the terms and conditions applicable for OS-MAIN-ARC 2018-19 shall be applied to this tender .

Enquiry No. & Date	658014E dt 16.09.2019
Due Date & Time for Submission Of Offer	09.10.2019 by 09.45 AM
Date & Time for Tender Opening (Other than Price Bid)	09.01.2019 by 10-00 AM

This tender specifies a set of prequalification criteria defining the eligibility for the vendors to quote against a particular Rate Schedule **(54AA)** of this tender. The Bidders are advised to go through all the enclosed Tender documents terms & conditions detailed under **Sections I to XII, Annexures- A to K,** and Rate Schedule carefully before submitting their Offer.

All the **Annexures A to K** should be filled, wherever applicable by the bidders without fail for evaluation of their offer and **all necessary / Self attested copies of the supporting documents** as required are to be uploaded in the portal. Copy of the uploaded documents are to be sent to the contracting authority.

The bid shall be submitted in three parts namely (1) EMD or Valid MSME certificate (2) Techno Commercial Bid and (3) Price Bid.

Kindly refer to the **Section-IV** – General Terms and Conditions of the tender for detailed procedure for submission of offers and details of exemption from submission of EMD for vendors registered with MSME

Kindly refer to Section-II to Section-IV for detailed scope. Tenders are hereby invited from experienced Contractors for the above scope.

Contact details / address for any clarification.

Deputy General Manager-(Contracts)
Outsourcing Department, Boiler Auxiliaries Plant
Bharat Heavy Electricals Limited, ,Ranipet-632406
Phone : 04172-284030, 284158, 284035, 241170
E-Mail : gsugumar@bhel.in, bsmanian@bhel.in, ssvasan@bhel.in

Deputy General Manager (Contracts)/OS

	Bharat Heavy Electricals Limited (A Government of India Undertaking)		☎: 04172-284030, 284158, 284035 241170
	Boiler Auxiliaries Plant, Ranipet – 632 406		
AN ISO 9000 COMPANY	OUTSOURCING DEPARTMENT		E-Mail :bsmanian@bhel.in ssvasan@bhel.in
Enquiry No	658014E	Due Date & Time for submission of offers	Prior to 09.45 Hrs On 09.10.2019
Enq-Dated	16.09.2019	Date & Time of Tender opening	By 10-00 Hrs On 09.10.2019
<u>SECTION II</u>			
Techno Commercial Terms & Conditions of the Annual Rate Contract 2019-20 for OS- Main- Wall Panel Fabrication			

Scope of the enquiry is to finalise the Rates for entering into Annual Rate Contract for the year 2019-20 for Complete Manufacture of casing walls Hopper Walls, Roof Panels , Gable Top/middle/bottom ,insulator pannels etc from raw materials/components supplied from BHEL. Vendor scope includes collection of raw materials from BHEL (single/multiple) and delivery of finished goods to BHEL shipping . All the terms and conditions applicable for OS-MAIN-ARC 2018-19 shall be applied to this tender .

1.0 Contract period for this Enquiry is One Year from the date of finalization of the contract. The Total Tonnage tentatively for this Rate Contract is 12,800 MT

- 1.1 For study and quoting of rates for Rate Schedule (**54AA**), Representative Drawings, sketches, against the Rate Schedule indicated in the tender for fabrication/Assembly are made available for downloading. The sample copies of actual drawings are kept at BHEL office for vendor study on all working days from Monday to Saturday from 09.00 Hrs to 16.00 Hrs. (up to 3 days prior to the due date for submission of tender).
- 1.2 Vendors are requested to have a perusal of these drawings, QWI, etc., before submitting their offer. No deviation or change from the Tender conditions will be entertained and BHEL reserves the right to reject such offers.
- 1.3 Based on the Rate contract, to be finalized, the Firms shall accept and undertake all jobs awarded to them under Rate Schedule allotted to them and execute them to the satisfaction of BHEL. Failure to comply with this requirement will be viewed seriously.
- 1.4 BHEL will conclude that the offer has been submitted by the firm, fully understanding all the requirements both explicit and implied and other conditions and accepting the same. After tender opening, contractors do not have any right to change / alter any of the conditions either partly or fully. Offers of any such firms doing so, will be rejected.
- 1.5 Vendors are requested to refer to **SECTION-IV** of this tender for (a) the applicability of EMD, (b) waiver available for EMD for MSME vendors and (c) procedure involved in submitting the offer in three parts.

2.0 FIRM RATES :

- 2.1 Please quote **FIRM** rates per MT as called for in **Price Bid** which are applicable to the firm (for Conversion Work only). The rate shall include the following and the operations called for in the conditions indicated in the tender.
- (a) The rate shall include all consumables for welding as stipulated in the drawings/QWIs /welding procedures and any indirect materials required for fabrication.(Any change in the consumable specification implemented /effected after finalizing the contract shall be reviewed and the rate shall be adjusted accordingly.)
 - (b) The rate shall be inclusive of the Transport Charges (inclusive of Toll Charges, if any) for Collection of Raw Material with allowances as specified in **Clause 3.0** and other components from Stores at BHEL, Ranipet and Dispatch of finished goods to Shipping/Stores at BHEL, Ranipet. (The rate shall be common for all vendors irrespective of the location/distance of their factory from BHEL, Ranipet). No extra transport charges shall be allowed for multiple collection and deliveries.
 - (c) Incase of transfer of raw material/semi-finished items from one vendor to another vendor, through IUWTV, the responsibility for collection of materials including the cost of transportation and handling etc. shall rest with Second Vendor (fabrication vendor dispatching the finished goods).
 - (d) The Rate shall include Transport charges (inclusive of Toll Charges, if any) for Return of balance material to BHEL, Ranipet Stores.
 - (e) The rate shall include machining of castings, forgings and fasteners which are supplied as free issue by BHEL, Ranipet.
 - (f) The rate shall include safe delivery of the finished fabrications as per QWIs and Drawings to withstand transit damages by rail/road.
 - (g) For safe delivery of export consignments as per QWIS / DRGS rates shall be quoted for the relevant extra rate schedules for payment of conversion charges shall be claimed as per remarks in the IR (**RS E72**). However in these export cases recovery on normal safe delivery charges will not be done. The extra rate schedule rate for the same shall be quoted accordingly. Supply of packing materials for such export packing will be supplied by BHEL free of cost.
 - (h) The rate shall include for protecting machined/threaded areas to avoid physical damages while handling, transportation and storage.
 - (i) Splicing of Structural, shall be done with prior permission from Outsourcing, BHEL, Ranipet.
 - (j) All Painting charges including Red Oxide painting / application of rust preventive oil as applicable shall be payable extra as per applicable extra Rate Schedule.
 - (k) Stenciling of Finished Product for Identification as per **Clause 8.5**
 - (l) The rate shall include for rectification of raw materials such as straightening, removal of bend, twist, etc. wherever necessary.
 - (m) For stainless steel fabrication, plasma cutting is not in the scope of sub-contractor. Special purpose welding, wherein materials of different specifications are to be welded (items like welding of alloy steel shafts of Fan damper etc.,) stress relieving of the same are not in the scope of sub-contractor. The rate shall be quoted considering this aspect.
 - (n) The rate shall include **LPI wherever required as per QWIs / Drgs /Sketches**. All other NDT charges like MPI/UT/RT etc payable extra as per **Clause 9.0**.
 - (o) Offering the jobs for inspection to BHEL /Customer or its authorized inspection agency is in Contractors scope and the quoted rate shall include the same.
 - (p) Not Applicable

- (q) The description and PGMAs given in the Rate schedule is only indicative. Any items of similar nature shall be loaded against Rate Schedule based on the work content. For payment purpose, only Rate schedule numbers shall be considered.
- (r) Wherever Trial assembly is called for in the drawings/QWIs or by Inspection, the charges as per extra rate schedule shall be payable extra. It should be indicated in IR **subject to approval by the concerned field officer.**
- (s) Not Applicable
- (t) **Note 1:** As the charges for shot blasting, painting, heat treatment and NDT (Other than LPI) are payable extra as per extra Rate Schedule, the rate quoted **shall not include** the cost of shot blasting, painting, heat treatment and NDT.
- Note 2:** The rates to be quoted for Rate Schedule requiring the intermediate operations (including shot blasting, painting, heat treatment, NDT) **shall NOT include** the cost of TO and FRO transportation and handling of the products to the respective firms and back. Where as separate Rate Schedules are added for the same. Hence whenever intermediate operations are required to be carried out, the Charges for TO and FRO Transport is payable extra.
- Note 3:** Vendors are requested to quote the rates for (RS) in Rs. per MT (OR) as applicable for conversion, scope of work, and meeting the terms and conditions of this tender in full.
- 2.2 The rates shall be FIRM and not subject to any variation/escalation on any account during the validity of this Contract period. The rates are operative for placement of job work orders valid for **One Year from the date of finalization of the contract** on Rate Contract basis to be entered into between BHEL and the Contractor.
- 2.3 The total available load will be distributed to the Contractors from time to time with whom Contract is entered into and to that contract the addenda shall be placed in a phased manner subject to the rank L1,L2,L3..,availability of potential and also depending upon vendor performance such as collection of materials in time, manufacture according to our plans/requirements, meeting quality requirements, sequential and timely dispatch of components, Prompt & Quick response, prompt returning & accounting of balance materials, Settlement of outstanding dues if any, and also the maintaining of minimum required facilities available at the Contractor's works to meet the job requirements and submission of such other reports as called for then and there.
- 2.4 The L1 Vendor will be loaded for more quantum, subject to other performance criteria specified above.
- 2.5 BHEL does not guarantee ordering of any minimum quantity or does not guarantee more share for the lowest tenderers. However, if the L1-contractors are performing well in terms of sequential dispatches and required tonnage interalia meeting the requirements laid down above, the same will be considered during loading.
- 2.6 "Notwithstanding anything to the contrary, including, but not limited to, provisions relating to extension of time and compensation/or delay, time shall be the essence of the Contract."
(The scope of Machining / fabrication, Customer approved Quality plan will be indicated in the PO as Addenda).
- 2.7 In case if the quantum of load is beyond the capacity of vendors in the opinion of BHEL or for shorter delivery requirements, BHEL reserves the right to extend/award the contract for manufacture of items covered herein to other probable new or alternative sources, without prior intimation to the contractors and BHEL's decision is final in this regard.
- 2.8 The Contractors are responsible till the Finished/Semi-finished components are safely deposited to BHEL, Ranipet. They should carefully pack, load, stack by providing wooden

reapers, etc. for avoiding damage during transit and lash the consignment properly at the time of despatch so that the consignment reach the destination safely.

- 2.9 Job Work orders will be issued after entering into Rate contract with the Sub-Contractors. Discrepancy in the JWOs if any, has to be settled immediately then and there within 10 days from the date of Job Work Order.

3.0 Raw Material Issues and Accounting :

The weight indicated in GMS/DRG/ and or as per Scope indicated in the PO addendum will be the basis for accounting of raw materials issued. For billing conversion / transportation charges if any the weight indicated in GMS/Drawing only will be considered. Raw materials will normally be issued with process allowance as given below for economical operations.

Description	Invisible wastage	Working allowance	Total process allowance
Sheets	2%	1%	3%
Plates	2%	2%	4%
Structurals (Beams, Channel, Angles, Flats Rods, Pipes, Tubes, Packing etc.,)	0.5%	0.5%	1%
** Plates of PGMAs 7xx42, 7xx44, 7xx45, 7xx46, 7xx47, 7xx49 and 7xx50. The number of permitted joints for these PGMAs are detailed in ESP:SQP:284:(Latest revision)	0.5%	1.5%	2%

** Generally cutting plan need not be required to submit by the firm for the plates of PGMAs 7xx42, 7xx44, 7xx45, 7xx46, 7xx47, 7xx49 and 7xx50 .(clause 6.4a not applicable). However, Cutting plan for the plates of PGMAs 7xx42, 7xx44, 7xx45, 7xx46, 7xx47, 7xx49 and 7xx50 should be submitted,

- if the issued weight is less than the demanded weight (for the purpose of completion of job),
- if the Issued weight is more than the demanded weight (for the purpose of declaration of off-cut).

If the difference (between the Issued and demanded weight) is less than the off-cut norms(CI.5.0), cutting plan need not be submitted by the firm for the plates of PGMAs 7xx42, 7xx44, 7xx45, 7xx46, 7xx47, 7xx49 and 7xx50 even if the weight is more than 5MT.

For all other cases cutting plan is to be submitted before taking up the job for fabrication as per clause 6.4.

Cleared material shall be collected by the Contractors at the earliest without any delay. If BG limit becomes a constraint to issue the cleared materials, vendor shall arrange for additional BG within 2 weeks time from JWO date/material cleared date, prior to material collection.

- 3.1 The Cutting Plans should be of "Optimum only", in order to maximize the utilization of the material issued, specifically where the left out material can better be used for other jobs. The balance material, if any after Cutting Plan approval/ machining / fabrication shall be returned to our Stores at Contractor's cost. BHEL reserves the right to call for the returning of the balance material notwithstanding its designation (ie. Whether Scrap / Big-size-Scrap).

(u) Not Applicable

- 3.2 Balance material arising out of issued quantity shall be returned by sub-contractor. However, if original issued quantity is insufficient due to the shape or size required to be cut, cutting plans may be furnished for BHEL approval WITHIN ONE WEEK OF DRAWAL of Raw

materials(However for Spiral Casing, Suction chamber and Silencer required for FAN Assy the Cutting Plan to be submitted within 15 days). Any off cut available from the original issue should be returned to us as per our approved cutting plan. Wherever the materials are supplied by BHEL for mockup test, welders qualification test, Etc., the material is to be treated as scrap on weight basis and material accounting to be settled accordingly.

- 3.3 Wherever firm comes across receipt of excess material due to the error in GMS/Drawings that is to be brought to the notice of AGM/OS immediately. Since material is issued on weight basis, any excess material received on account of section weight variation or otherwise, the same is the property of BHEL, notwithstanding the status of MAS. Such information shall be declared by the supplier to BHEL immediately.
- 3.4 Inventory statement has to be submitted every month by the firm for the free issued materials. If the Fabricator fails to produce or properly account the materials so issued, BHEL, Ranipet will have the right to take further action as deemed fit including recovery of the value of the materials along with the respective administrative charges and statutory levies from the running bills of the Fabricator / temporary suspension of load / termination of contract / de-listing.
- 3.5 Any act of Contractor resulting in dishonest misappropriation or conversion of the materials so issued for his own use shall constitute the offence of Criminal Breach of Trust under Indian Penal Code and /or such other offences under any other provisions of law and the Contractee shall have every right to proceed against the Contractor under Criminal Law in order to ensure proper punishment to such perpetrator/s for the said offence/s. In such cases, BHEL shall take all necessary steps to recover the material available with those firms.
- 3.6 Movement of BHEL materials from Contractor's premises to any other Firm(s), if necessary, for the purpose of production related work shall be documented properly, signed by the sender & receiver and the same to be authenticated by the concerned OS official, otherwise such materials will be treated as shortage by BHEL Accounts.
- 3.7 Protecting the material issued by BHEL under safe custody until completing the delivery as required is vendor's responsibility.

4.0 Working Allowance:

After scrutinizing the design documents, whenever additional allowance is required due to more volume of machining process, the process planner is authorized to increase/decrease the **working** allowance. Cutting plan must be submitted by the vendor for such cases. This is done to avoid unnecessary raise of supplementary MIV. Whenever the demand weight is **low** and less than off-cut weight, the process planner is entitled for giving net weight credit (NWC) to the firm, **instead of raising MIV**.

- 4.1 Wherever shearing and punching, raisal of supplementary MIV are involved, No process allowance is applicable. No invisible wastage will be allowed for the following:
Sheet 2 mm in Screen Sheets 7XX 08 PGMA's, Stainless steel material, dia 8mm bright bar for EE holder, Retainers processed by Punching, haste alloy material in Damper & Gate Seals, Shock Bar Plate of RS No :160 **and perforated sheets 2mm used in FAN Silencers**.
- 4.2 For HASTE ALLOY MATERIALS the weights of component as per drawing will hold good for accounting of raw materials. Raw material will be issued in running meter for haste alloy material and since coils are in running meter, there will be no process allowance for all shearing operations. The Carbon steel (CS) portion of Haste alloy welded seals must be painted with one coat of synthetic enamel paint or as per specific requirement of the customer, the painting charges will be payable extra as per extra rate schedule and all seals must be packed as per BHEL'S requirement. The contractor will have to return all the balance material of haste alloy strip, in issued width, to BHEL/Ranipet Stores at contractor's cost.

5.0 Scrap / OFF-Cut Norms :

SI	Description	Scrap Size (mm)	Off Cut Size (mm)
----	-------------	-----------------	-------------------

1	CS/AS Sheets & Plates	Below 500 X 250	500 X 250 & above
2	Rolled Sections Including Structural(other than CS/AS rods less than dia 40mm/tubes/pipes): Length	Below 1000	1000 & above
3	CS/AS Rods greater than dia 40mm, RHS, SHS, Tubes and Pipes: Length	Below 500	500 & above
4	SS Non Ferrous Sheets & Plates	Below 500 x 250	500 x 250 & above
5	SS Non Ferrous Structural, rods, tubes, pipes: Length	Below 250	250 & above
6	Haste Alloy Length	Below 250	250 & above
7	Big Size scrap Length x Breadth CS/AS	(2500 & above)X (150-249)	-----
8	WSTE/NAXTRA Materials.	Below 500 x 250 Below dia 350	500 x 250 & above Dia 350 & above

The issue of various wool, CAF Joints, Asbestos rope etc. will be as per required Quantity. Excess material issued if any will be treated as scrap in view of practical problems (Re-Packing, verification, receipt, accounting, storage etc.)

- a) All Off-Cuts (Ferrous, Non-Ferrous, SS etc.) are to be returned to BHEL stores with RSV at contractors' cost.
- b) Returning of Off-Cuts/Prime material to BHEL is mandatory. Failure to return the materials (prime material/off-cut) will entail recovery of the cost of materials along with GST duty, & other Statutory levies as applicable plus departmental/administrative charges fixed from time-to-time **cl.6.7** from any of the running bills of the supplier/other means of recovery available for the non-returned quantum. The non returned quantum of material (Prime/off-cut) will be as per FMAS approved by BHEL.
- c) Wherever the materials are supplied by BHEL for mock-up test, welders qualification test etc. (except for Nitriding & Case Hardening), the same will be treated as scrap as classified above.

5.1 All scraps (Ferrous, Non-ferrous, SS, CS/AS, WSTE etc.,) including Turnings and borings need not be returned to BHEL. Contractors can dispose the above scrap, on completion of Final-Material-Accounting for the respective IP. Necessary cost shall be recovered along with ED, Sales Tax and any other statutory levies if applicable.

5.2 The Rate Schedules for recovery of different types of scraps are as follows:

Sl.No.	Description	Rate Schedule
01	Recovery rate for Scrap of CS/ AS, Asbestos, wool, CAF etc.,	E41
02	Big size scrap (CS/AS sheets/plates)	E42
03	Recovery Rate for Scrap of Stainless Steel (NON Magnetic), NON –Ferrous Metals.	E43
04	Recovery Rate for Turnings and Borings scrap of CS/AS	E44
05	Recovery Rate for Turnings and Borings scrap of SS Non magnetic , Non Ferrous	E45
06	Recovery Rate for Turnings and Borings Scrap of Stainless Steel- Magnetic	E46
07	Recovery Rate for Stainless Steel magnetic scrap	E73

As far as the Recovery RS u/E44, E45, E46 prevailing rates shall apply for this contract also.

5.3 For machining/drilling jobs, the Turning & Boring scrap generated shall be accounted and recovery will be made as per Scrap norms as given in **Cl. 5.0 , 5.1 and 5.2**. For SS and nonferrous 100% of T&B scrap will be recovered.

6.0 Disposal of Scrap and Return/Accounting of Balance Materials:

Contractors who wish to dispose off the scrap from their end are permitted to do so subject to the following conditions:

- (a) They should possess GST Registration under GST Act and GSTIN NO. under GST Law. Copies of the same shall be furnished to Manager /Finance/BHEL, Ranipet.
- (b) The recovery for the above all categories of scrap will be as per the Final Material Accounting Statement (FMAS) approved by BHEL and as per the ARC Rates signed by BHEL and Contractors.
- (c) However GST applicable for all the scrap disposed off at the Contractor's end will be to their account. BHEL will not reimburse this amount. Necessary GST formalities are to be followed by the Contractor.
- (d) GST on scrap will be recovered as applicable
- (d) Scraps shall be disposed off only after submission and approval of Final Material Accounting Statement (FMAS) by BHEL

6.1 Wherever attested materials are issued, the balance materials are to be returned only in the attested condition. Otherwise **Cl. 6.7** below will be applicable.

6.2 The materials rejected as PDO due to reasons attributable to vendors like (a). Faulty workmanship, (b). Improper storage of raw material issued by BHEL (c) improper handling (d) improper packing etc.. Will entail recovery at prime material's cost as per **Cl. 6.7**.

6.3 The materials rejected due to other than reasons **u/cl.6.2** shall be returned to BHEL, Ranipet Stores failing which recovery will be made as per **Cl. 6.7**.

6.4 The material supplied by BHEL, Ranipet shall properly be utilized as per the Scope in Contract/drawings/QWIs in job work order to meet the design and quality requirements of the product. Hence economic cutting plans are required to be submitted by the Contractor for approval in the following cases:

- (a) For sheets, plates & structural where the original issued / transferred(IUTV) quantity is more than 5 MT.
- (b) Whenever the issued quantity is insufficient owing to shape or size.
- (c) All stainless steel/Haste alloy/Non-ferrous items.
- (d) Excess issue in weight against demanded quantity wherein the excess quantum is more than off-cut norms (**vide Cl. 5.0**).
- (e) For items like flanges, rings, cover plates, etc. where demanded weight is in excess of net weight with higher rate of process allowance. (However cutting plans need not be submitted where the collected material weight and net weight difference which is less than off-cut weight). In any case, cutting plan need to be submitted for issue weight 5 MT and above.

6.5 However, in working out such economic cutting plans, it is to be ensured that the details furnished by the contractor are as per current GMS, Job works order & IOM and meets the requirements as prescribed in QWIs shall have to be adhered to. After the approval of the cutting plans, any off-cut, available from the issues made either in original or in supplementary shall be returned to the BHEL, Ranipet Stores at the Contractor's cost. The cutting plans as approved by the Outsourcing, BHEL, Ranipet shall be kept at the Contractor's premises and to be made available as and when demanded by the BHEL Officials or their representatives. It should also be ensured that the jobs shall be as per the approved cutting plans. All returnable materials (prime/off-cut) as per Cutting Plan approval covering letter

shall be returned to BHEL, Ranipet Stores immediately without waiting for the W.O./P.O completion to avoid any payment hold and subsequent recovery.

- 6.6 Whenever machining / fabrications are done without proper approved cutting plans, any loss of material arising due to the same will be recovered at prime materials cost including the process allowance indicated in **CL. 3.0 & 4.0** plus Departmental / Administrative charges fixed from time to time (**vide Cl. 6.7.**). In addition, statutory taxes, duties and levies etc., applicable will also be recovered from the Contractor and also other actions as deemed fit will be taken and no claim for refund will be admitted by BHEL, Ranipet. BHEL's approved cutting plan is final.
- 6.7 Failure to return the materials (prime/off-cut) will entail recovery of the value of the materials plus departmental/administrative charges fixed from time to time. Currently the departmental/administrative charges are 25% for indigenous material and 50% for imported materials on the material value. In addition, statutory taxes, duties & levies as applicable will also be recovered and no claim for refund will be admitted by BHEL, Ranipet. The rate of departmental and administrative charges as applicable from time to time irrespective of the date of failure will be applicable. Besides penal interest will be levied on the material value, for the period starting from date of issue of material.
- 6.8 Where an increased allowance over the process allowance as stated in **CL. 3.0 & 4.0** is necessary, the same will be issued after scrutinizing and approval of cutting plans.
- 6.9 For the purpose of material accounting after completion of a particular WO, BHEL/OS department will issue a preliminary material accounting statement thro' E-mail, the next day of completion.
- (a) The Contractor shall respond within 7 days of receipt of Preliminary MAS, Either by Accepting the Pre-MAS OR submit their own MAS (Contractor/Firm-MAS) in the case if the Pre-MAS is not in line with the requirement.
- (b) Any discrepancy Like weight correction, DU correction, variation in off-cut /scrap quantum etc., as indicated in Pre-MAS will have to be reconciled with the Material Accounting section with necessary proof of documents within a week from the date of issue of Pre-MAS. If reconciliation is not done within a week, it will be treated that Pre-MAS is correct in all respects
- (c) If the Pre-MAS is accepted by the Contractor, BHEL will prepare, within 7 days, the Final-MAS.
- (d) In case if Pre-MAS is not accepted by the Contractor, the Contractor/Firm-MAS submitted, if any, by the Contractor will be considered and if no such Contractor/Firm-MAS is submitted also, BHEL will prepare a Provisional-MAS and send through email, within a week.
- (e) If the material (CS/AS) to be recovered as per BHEL MAS working is within plus or minus 10 Kgs with respect to Contractor/Firm-MAS, then final MAS will be released with out Pre-MAS acceptance.
- (f) For Deleted /Diverted Job Work orders, Final material accounting should be settled within 14 days time, after deletion/diversion. Otherwise, BHEL will prepare Final-MAS on completion of 14 days of IOM date on suo-motto basis. For exceptional cases with reasons attributable to BHEL, a further relaxation of 1 week will be given on the certification of respective field officers (Please Refer **Section VI** on work-flow for details).
- (g) The response if any received from the Contractor, will be studied and considered and Final MAS will be prepared. In case if no response is received, the provisional MAS will be treated as 'Final' MAS and accordingly, Final material accounting statement (FMAS) will be issued. BHEL will prepare the FINAL MAS within 30 days of DC control.

- (h) After completion/cancellation of (Issue Position) IP the Contractor has to submit Contractor/Firm MAS comprising material issue cum working details, contract and receipt statement as per the format specified by BHEL for entire IP within 7 days from the date of delivery of last despatch or on date of submission of 100% invoice whichever date falls earlier of the respective IP. Further to, Contractor should certify the submission of bills with 4 (5)(a) Challan's duly signed with seal in part II including completion of all transactions like cutting plan approvals, return of BHEL Material on RSV, IUWTV controls and submit along with MAS.
- (i) Once the IP is closed as mentioned above no re-opening of IP except recovery from running bills will be entertained.
- (j) The contractor shall be bound by the accounts, statements acknowledgement of materials, BHEL material issue documents, receipts etc., wherever signed by their representative.
- 6.10 Return of any balance material to our applicable Stores-Ward at BHEL / Ranipet immediately after cutting plan approval.
- 6.11 Recovery towards non-return of balance material as per FMAS will be done as per Contract norms along with statutory taxes, duties & levies as applicable from any one of the running bills OR from other means of recovery available Hence, any correction after the issue of FMAS, the job work order will be treated as closed in all respects thereby any requests towards refund of recovery, if any, will not be entertained.
- 6.12 Wherever MAS not required to be submitted, in case if the material (CS/AS) to be recovered as per our MAS is within (+) or (-) 10 Kg and there is no material collection is involved, BHEL will prepare Final-MAS on suo-motto basis and Recover/Net-weight credit will be provided accordingly.
- 6.13 Please note that the Contractor is responsible for prompt material accounting and settlement of outstanding dues towards non-return of balance material. Repeated occurrence of inordinate delay in settling the material accounting / outstanding dues will entail BHEL the right to terminate the contract forthwith or to impose temporary suspension on further loading at the discretion of BHEL, Ranipet. Also in case of non-return of material or non-submission of material accounting statement, BHEL reserves the right to en-cash the Bank Guarantee / Fixed Deposit Receipt submitted by the Contractor and initiate legal action against the Contractor against this contract OR any other contract, in addition to the other means of recovery from contractor, available with BHEL.
- 6.14 The raw material issued to the Contractor as free issue shall remain the property of BHEL, Ranipet. The Contractor shall use the above material only for the execution of BHEL'S contract/addenda and for no other purpose whatsoever. The Contractor shall be responsible for the full value thereof to be assessed by BHEL, Ranipet whose decision shall be binding on the Contractor, The Contractor shall be liable for the loss or damage to such property while such property is in the possession or under the control of the Contractor, their employees, workmen, representatives or agents or any other person connected with the Contractor. The Contractor should execute an agreement in **Rs. 100/-** non- judicial stamp paper and maintain the secrecy of the design, know how of BHEL products.
- 6.15 All the materials of BHEL, Ranipet shall under no circumstance be hypothecated/leased/liened /encumbered to any bank or to any lending Institution or to any party whomsoever. It should not also be shown as the Contractor's assets in any of the statements of the Contractor to any party.
- 6.16 The Contractor shall, whenever required, produce the materials supplied as free issue by BHEL, Ranipet in the form of raw material, semi-finished or fully completed boiler components to BHEL officials visiting the Contractor's unit for verification purposes. If the Contractor fails

- to produce or properly account the material so issued, BHEL, Ranipet will have the right to take further action as deemed fit including recovery of the value of materials along with the respective administrative charges and statutory levies from the running bills of the Contractor (with BHEL, Ranipet and with other Units of BHEL) and also any or all of the actions such as, Suspension of business dealing, temporary suspension of loading, termination of Contract, holding the payment due etc., Similarly for the claim made by any units of BHEL (on account of such vendor) to the BHEL, Ranipet, the Bank Guarantee submitted to BHEL, Ranipet will be encashed.
- 6.17 As and when required/applicable, BHEL, Ranipet will transfer(or advice for returning u/RSV) the balance material available including scrap size available for which PO/Issue Position(IP) is not closed, from one Contractor to the other contractor/other IP of the same contractor. For this, necessary credit will be given in material accounting, the material transfer emanating from Outsourcing, BHEL, Ranipet is to be honored by the Contractor within 15days or otherwise recovery will be made at the prime material cost., Any difficulty for effecting such transfer shall be brought to the knowledge of OS/ BHEL, Ranipet officials immediately.
- 6.18 The Contractor is responsible for submission of CLEAR material accounting statement (MAS) i.e. ensure that all transactions are completed (including IUWTV/RSV, supplementary material collection, submission of cutting plan, etc.) within 7days from the date of completion of work order & failing, without prejudice to other rights under Contractor, law or otherwise, which MAS will be closed suo motto basis and recovery of the scrap/off-cut will be effected after adjusting of balance payment due to the Contractor from any of the running bills. Delay in settling the material accounting will entail BHEL the right to terminate the contract forthwith or to impose a temporary suspension on further loading at the discretion of BHEL, Ranipet.
- 6.19 For any IP if the total requirement of carbon steel plates of 5mm to 10mm thick is 20 kgs or less, Contractors have to use the required material from the balance material of other work orders. However, these quantities will be adjusted as Net Weight Credit (NWC) during material accounting.
- 6.20 Raw materials will be loaded by BHEL, Ranipet either in lorries/trailers/ bullock carts and can be overseen by Contractor's representative at BHEL Stores / Shop. Shortage or variation in quantity, size and weight shall not be accepted once the material leaves BHEL, Ranipet Stores. Raw materials will be issued by BHEL, Ranipet, only after the receipt of necessary Bank Guarantee as per **Cl.20.0 and 21.0.**
- 6.21 Where an entity (whether a proprietorship, partnership, company, Hindus Undivided Family or otherwise) commits a default or breaches the Contract and the proprietor/ partner/ director/ member of such entity is also a proprietor/ partner/ director/ member of another entity that is registered with BHEL (in Ranipet or any other unit of BHEL), BHEL shall have the right to recover losses due to the default or breach, whether direct, indirect or consequential, either from the defaulting/ breaching entity or the other said entity or both. Such right shall also include the right to encash any security (in any form such as but not limited to bank guarantee, demand draft, FDR, etc.) furnished by either or both entities. Without limiting the applicability of the foregoing, it shall not be a defence to the other said entity for enforcement of such a right that:
- (a) Both entities are legally distinct/ separate entities, or
- (b) The management of the entity/ partners/ directors/ members of such other entity were not aware that the proprietor/ partner/ director/ member of the defaulting/ breaching entity was also a proprietor/ partner/ director/ member of the other said entity.
- 6.22 The Contractor shall be bound by the accounts, statements acknowledgement of materials, receipts etc., wherever signed by their representatives.

- 6.23 The value of the materials and statutory levies towards non-return of off-cut/scrap wherever applicable will be calculated at the rate prevailing as on the date of accounting and demand thereof by BHEL irrespective of the date of failure for return of the off-cut/scrap by the Contractor.
- 6.24 For the Contractors who come under **Cl.28.0(B)**, the scrap arising out of the issued raw material shall be disposed off as per **Cl.6.0**.
- 6.25 For TAPH, Gates and Dampers jobs where generation of turnings and borings scrap is involved, the Contractor shall declare the quantum of turnings and borings scrap to be generated duly certified by OS and only 70% of the declared T and B scrap will be recovered as per **Recovery Rate Schedule RS E44 to E46** Taxes and other statutory levies as applicable at the time of recovery. In these cases, no invisible wastage will be allowed in addition to the non-collectable scrap of 30%. Balance materials will be treated as off-cuts/scrap as the case may be. However for SS turnings & boring being generated the Subcontractor has to declare 100% of the T&B generated and recovery as per RS E45 with Taxes & other statutory levies will be made. In this case NO invisible allowance will be applicable. Balance material will be treated as offcut/ scrap as the case may be
- 7.0 Surface Preparation:** Surface preparation to a cleanliness level of Swedish Standard Protective Coating (SSPC) Sa 2 ½ (near white metal finish) i.e " Removal of loose mill scale and loose paint, to the degree specified, by the impact of abrasive blast propelled through nozzles or by centrifugal wheels. Near white blasted surface shall be free of all visible oil, grease, dirt, mill scale, rust, paint, oxides, corrosion products, and other foreign matter, except for staining limited to not more than 5% of the surface area. Such staining may consist of light shadows, slight streaks or minor dis colouration caused by stains of rust mill scale, or stains of previously applied paint.
- 8.0 PAINTING:** All painting works shall be part of main fabricators responsibility, including cost of paints. However extra rates are payable as per extra rate schedules (listed under Heading "Charges for Painting" in **Section-III-D** titled "List of Extra Rate Schedules"). The fabricators are advised to quote their rates for each Rate Schedule per Sq.meter basis. ALL PAINTING CHARGES (PRIME/FINISH/SPECIAL PAINTS ETC) PAYABLE EXTRA AS PER EXTRA RATE SCHEDULES. The paints shall be procured from BHEL-Approved paint manufacturers list given in **Section-VIII**
- 8.1 The finished/Semi-finished components shall be cleaned by power operated wire brush and painted with primer as per QP/ QWIs/ CIS purchased from our approved paint manufacturer's list hosted with this tender as **Section VIII**.
- 8.2 For all painting over and above the Primer painting whenever required, the finish paint as per applicable QWIs/CIS shall be applied.
- 8.3 For all painting including primer painting , the charges shall be payable as per applicable extra rate schedule.
- 8.4 For painting of Extra Coating thickness with reference to coating thickness mentioned in the extra rate schedule description pro-rata charges shall be payable extra based on IOM issued by BHEL/OS.
- 8.5 Unless stated specifically Foundation material, columns up to zero level need not be painted with red oxide. Further, the fabricated semi-finished components shall be legibly stenciled with the Project Name, Work Order Number, DU Number , quantity, weight, Sub-contractor's code Number, match mark no., etc., for identification and dispatched as may be advised.

- 8.6 Sub-contractor code number alone shall be punched using ½ inch letter punch and bordered suitably for easy identification. All the identification marks shall be coated with an overcoat of transparent varnish to protect against weather.
- 8.7 Application of one coat of the specified primer painting is to be done immediately after Blast cleaning as per the stipulated dry film thickness (DFT) normally varies from 35 microns to 100 microns.
- 8.8 Machined surfaces and Retainers shall be applied with rust preventive oil in place of red oxide.
- 8.9 Whenever blasting by Grit/shot for surface preparation is to be done, the applicable ARC rates will be payable extra. The allied To & Fro Transport charges are also payable extra as per the respective extra Rate Schedule and a self certified declaration from the fabricator (certified by Field officer) is to be enclosed by the concerned fabricator , along with their respective invoices to the effect that the components are blasted not in their works but else where .
- 8.10 Whenever galvanizing is to be done the charges for Galvanising and The allied To & Fro Transport charges are also payable extra as per the respective extra Rate Schedule. Whenever the galvanizing is done at Galvanizing source, who signed Annual Rate Contract **(ref. Section-VIII)** exclusively for galvanizing rate schedules, the charges for galvanizing will be directly paid to Galvanizing supplier against their Job Work order and respective invoices.
- 9.0 UT/RT/HT/SR:** The Ultrasonic Testing, Radiographic Testing, Heat Treatment and Stress Relieving as called for in the drawing/QWI/JWO are to be carried out by the fabricator, through the approved agency of BHEL. Approved agencies are as per **Section–VIII**. For Charges for carrying out of the above operation is payable extra as per the extra rate schedules and allied To and Fro Transport charges are also payable extra as per the respective extra Rate Schedules. In case there is no approved agency near vendor's works, vendor may locate suitable agency for RT, MPI, LPI, SR and UT and get them approved by BHEL before commencing the job. For such approval, the agency has to fill up relevant Vendor Registration Form available with BHEL.

10.0 EXTRA RATES FOR CONVERSION:

Rates for the special requirements like Special Painting, Heat Treatment, Transport Cost for Intermittent Operations etc. other than RS specified in this tender are to be finalized through Extra Rate Schedules in this tender. **Totally 72 number of Extra RS involved ie. E 01 to E 101**

Rates as per extra rate schedules shall be payable extra as per remarks in the IR. The extra Rate Schedules are applicable for all the contractors. The rate finalized for RS-NO. 185A for "Surface preparation equal to shot blasting " will also be operated under Extra Rate Schedule-E08.

Any other extra work not covered under extra RS, but incidental to the completion of fabrication job till handing over to BHEL, shall be deemed to be part of the main fabrication rates.

- 10.1 **Conversion of Sections:** In a situation where flats of various sections called for in the assembly are not available, plates will be issued for conversion into flats. Also, you may be required to convert channels/angles to another size for which extra charges are payable (as certified by OS officials based on certification made in the IR) for the net weight of finished section as per the Extra Rate Schedules.

- 10.2 whenever substitution are offered which involves higher / lower work content, the charges shall be paid extra/ recovered as the case may be.
- 10.3 **For Additional Joints:** In case any additional joints **made over and above the drawing /QWI requirements** with prior approval of BHEL owing to the non-availability of required size of raw materials is **applicable** only for the following, rate schedules. **Rates for extra joints includes cost of LPI/MPI charges also.**
- The Sub contractor can claim extra rate as per applicable extra rate schedules based on IR and certification from OS expediting officials..
- 10.4 For all jobs wherever optional joints are mentioned in the drawing, no extra rates are permissible. For Ducts no extra rates are permissible for joints.
- 10.5 The fabricator can claim extra rate as per applicable extra rate schedules for any additional joints put up by fabricators during fabrication, over and above called for in the Drawings and based on IR and certification from OS officials for applicability of extra rate for additional joint enclosed along with fabricators invoice.
- 10.6 Extra rate for Radiography, UT and for MPI alone are applicable. However, **NO extra rate** is allowed for LPI. Rates as per extra rate schedules shall be payable extra for Grit/ shot blasting, painting (all type) of painting, HT & NDT charges (Other than LPI) etc.,
- 11.0 TRANSPORT CHARGES :** Tender calls for the offers on F.O.R-Destination basis (ie. Freight charges inclusive in the quoted price), hence No Transport Charges payable extra for the Raw Materials / Components collected from BHEL and return of finished items vice-versa.
- 11.1 Incase of transfer of raw material/semi-finished items from one vendor to another vendor, through IUWTV, the responsibility for collection of materials including the cost of transportation and handling etc.. shall wrest with Second Vendor (fabrication vendor dispatching the finished goods).
- 11.2 No extra charges towards transport will be allowed for multiple collection & deliveries (due to various reasons including 1. Part-qty available for collection, 2. Part-qty required to be delivered by vendor.
- 11.3 **Additional Transport Charges:** Transport Charges incurred by the vendor for any special intermittent operations other than specified in the Rate Schedules or any additional movement requested by BHEL officials in writing, the transport charges payable extra as per the Extra Rate Schedules available in the contract.
- 11.4 For return of PDO materials thro RSV (PDO other than reasons **u/cl.6.2** like issue of faulty materials, non suitable materials, any drawing revision etc), TO & FRO transport charges as per applicable extra rate schedule shall be payable extra.
- 11.5 The Rate payable against the Extra Rate Schedules are inclusive of Toll charges, if any.
- 12.0 Recovery of Transport Charges:** If the materials are delivered/collected by BHEL/BHEL approved transport contractor when the scope of transport is with vendor, the freight charges incurred by BHEL will be recovered from the vendors.
- 12.1 If Purchase Order is placed with delivery destination other than BHEL-Ranipet, the respective transport charges for delivering the finished job is to BHEL's Account and the amount of transport charges (already included in the rates finalized for the RS) for delivering to BHEL-Ranipet is deductible.
- 12.2 **Dispatch of finished goods Direct to Site (DTS):** Wherever necessary, BHEL may advise fabricators to dispatch finished goods directly to site with transport charges to BHEL's Account. The scope includes loading of finished products on truck for dispatch to respective

BHEL-site offices/BHEL's-Customer. In such cases the cost of transportation from Contractor's works to BHEL,Ranipet, not incurred by the vendor shall be recovered from the vendors.

For all the above, the recovery of Transport Charges will be made as per Extra RS E07X, E07Y and E07Z which is to be finalized in OS MAIN ARC tender.

13.0 PAYMENT FOR EXTRA CHARGES : 100% Payment will be made for extra charges against Invoice supported by acknowledged Delivery Chelan and Inspection Report (IR) issued by BHEL Inspector/agency. **The payment of extra charges will be made only to the Extra RS Nos, UNIT, Qty mentioned in the IR duly concurred by BHEL Field Officers.**

14.0 SAFE DELIVERY: The Contractor shall do at his cost the necessary packing for easy & safe handling and transportation as per BHEL drawing wherever specific packing arrangements are applicable and normal packing for the other items required for transit by rail/road transport wherever necessary.

15.0 TERMS OF DELIVERY: The price should be on "F.O.R- BHEL Stores/Shipping, Ranipet" basis only (Inclusive of packing, forwarding and freight charges).

The finished machining / fabrications on acceptance by BHEL, Ranipet inspector or by their authorized inspection agency shall be delivered to BHEL, Ranipet Stores / Shipping or to BHEL Sites / Customer as the case may be immediately.

16.0 TECHNICAL REQUIREMENTS :

16.1 The machining / fabrications shall strictly confirm to the dimensions and tolerances indicated in the drawings/QWI. Care must be taken to adhere strictly to the NOTES given in the drawings/Contract. It should be ensured that actual dimensions, and deviations if any, are recorded properly in the D.R. books and preserved at least for 5 years. The same shall be made available to BHEL Officials or their authorized agencies.

16.2 Any other work carried out outside the requirements of drawings/QWIs shall have the prior approval of the competent authority of Outsourcing / BHEL, Ranipet.

16.3 Adequate facilities like welding equipments, baking oven, handling facilities and measuring instruments as called for, must be available duly calibrated and kept with the Contractor for the manufacture of boiler components. All the above basic machining / fabrication facilities/equipments must be under working condition and the same be made available for verification by the BHEL officials or their authorized agencies whenever they are called for.

The instrument/gauges are to be calibrated periodically as follows:

Sl.No.	Type	Periodicity
01	Measuring instruments / gauges	One year
02	Limit Gauges (Eg. Plug/ring)	One year
03	Temperature , Pressure gauges	6 months
04	Measuring Steel tape	Once

Calibration status shall be displayed at the Contractors works in a conspicuous location. Calibration can be performed either at BHEL or at any Govt. approved labs traceable to National Standards.

16.4 For Rate Schedule, the manufacturing, handling and testing facilities requirement as specified by BHEL from time to time shall be available with the Contractor.

- 16.5 Only the right kind of matching welding electrodes shall be used as called for in the drawings/QWIs after necessary baking and pre-heating mentioned in QWI. Welding electrodes shall be sourced only from approved vendors as per **Section-VIII**. The electrodes shall be suitably baked and preheated wherever applicable before use in addition to the general precautions that may be applicable for all electrodes in storing etc...
- 16.6 Welding to be carried out by Qualified Welders and as per BHEL Approved Welding Procedure Specification (WPS). Necessary raw material for conducting the pre-production test will be supplied by BHEL as supplementary materials. The welder qualification and welding procedure will be done by QC, BHEL or by their authorized agency.
- 16.7 All welds of Submerged Arc Welded components shall be carried out by certified welders and shall be dye-checked for root and by MPI for final welding.

17.0 INSPECTION:

- 17.1 Inspection of fabrications/Machinings (conversion work) shall be by BHEL Quality control department and/or by the customers and/or by an agency or persons authorized by BHEL, Ranipet at the Contractor's works including Self Inspection firms. Selected firms shall be approved by competent authority authorizing self inspection. The concerned Engineer/supervisor/Authorized Official of the firm authorized by the firm to carry out all Inspection activities and their authority/activities shall be on par with any other Inspection agency approved by BHEL (like TUV/IRS/INTERTEK etc.,). All facilities and equipments, calibrated instruments like tapes, thread checking gauges upto M20, and bore dial gauges and bits up to 100 mm. and standard gauges required for inspection shall be provided by the Contractor free of cost.
- 17.2 BHEL representatives/authorized agencies will have free access to the Contractor's works at any time during the execution of job work orders as well as for verification of requisite documents/materials. (The requirement of Customer approved quality plan will be indicated in the PO/Addenda).
- 17.3 The semi-finished components are deemed to have been accepted as ready for delivery only after IR is released by the Inspecting Agency.
- 17.4 Statutory inspection requirements such as IBR/External Inspection agency requirements if any, are to be met by the Contractor.
- 17.5 The paint quality will be checked by BHEL Ranipet at regular intervals. Samples will be collected from vendor works and will be tested at BHEL to ensure quality as per relevant standards. In case of discrepancy in meeting our specification the job may be rejected/vendor may be put under suspension of business. **The vendor shall ensure mentioning of the details of paint applied, no of coats, coating thickness on the respective IR of the job.**

18.0 PAYMENTS :

- 18.1 Payment will be made for IP wise 100% for the supplies made against submission of Vendor invoices in duplicate to Finance section furnishing the job work order Sl. No., W.O., IR & DC No. along with IR, giving details of work carried out as per Extra Rate Schedule applicable, if any supported by
- (a) Stores Receipt Voucher in case of Stock Work Order items.
 - (b) Delivery challan acknowledged by BHEL Stores/Shipping.
 - (c) Inspection Report (IR)
 - (d) If the claim is made for more than one job work order Sl. No., only one invoice have to be submitted with annexure giving the above details.

- (e) Contractor MAS with challans duly signed with seal in part II.
- (f) finished goods are dispatched directly to site (DTS) from fabricators works as per BHEL instructions, necessary formalities to be followed as per BHEL conditions stipulated from time to time . Also in such DTS cases, the documents like copy of DC, Lorry Way Bill etc shall be submitted along with their invoices for payment purposes.
- 18.2 The amount due to BHEL, Ranipet, if any, will also be recovered from the Contractor's running bills. No request for the refund of penalty/recovery will be entertained after final material accounting is done. Payment will be made only through 'Electronic Fund transfer/RTGS Transfer'. Acceptance for the same may be submitted in the prescribed format if not done already.
- 18.3 Owing to the substitution, if the raw material weight changes over and above (+) or (-) 5%, the conversion cost for the difference in weight shall be paid/recovered prior to the issue of FMAS. Since payment is made for notional design weight, any correction issued for the design weight after processing the original invoice, Contractor is entitled to raise another invoice for the difference in weight without any other supporting document except the copy of the original invoice.
- 18.4 Payment will be restricted to two bills per Work Order or Job Work Order Sl. No. only. Excise Duty as applicable for Contractor's covered under **clause 28.0**, can be claimed along with documents / certificates mentioned therein. However, one more bill per month against any one of the pending Work Orders will also be permitted as a special case and this should have the prior approval by competent authority.
- 18.5 The Contractor shall ensure that ALL claims including extra charges, if any, as per **Cl. 4.0** are made against the particular work order before the issue of Final-MAS since BHEL will not be able to reopen the case after issue of Final-MAS.
- 18.6 The payment shall be subject to the deduction of any amount for which the fabricator is liable indirectly under this contract or any other contract of the fabricator or any other fabricator's contract where the proprietor / any of the partners / directors of the present fabricator is / are proprietor/director/s/partner/s, in respect of which BHEL / Ranipet is a contractee.
- 18.7 Request for delivery extension is to be made if there is a valid reason, in the format for that particular job work order Sl. No., failing which liquidated damages will automatically be levied as per **Cl. 23.0**. No request for extension/refund of penalty will be entertained there after.
- 18.8 Payment will be made in about 45 days after receipt of valid invoices raised in accordance with **Cl. 18.1** and supported by full set of necessary documents at Accounts Department. No interest shall be payable by BHEL on any money due to the Contractor by BHEL.
- 18.9 For the purpose of payment, only the unit rates are to be considered based on the RATE SCHEDULE NUMBERS. The description of the item is only indicative and it is not binding. Any description given in the item column is only for the purpose of clarity for manufacturing the item. (the description may change designer to designer and/or drawing to drawing).

19.0 PROGRESS REPORT:

The Contractor shall submit progress report from time to time and also discuss with our officials concerning the progress of the work and commitment as may be required by BHEL, Ranipet. The submission, receipt and acceptance of such reports shall not prejudice the rights of BHEL, Ranipet under the Contract nor shall operate as an estoppels against BHEL, Ranipet merely by reason of the fact that they have not taken notice of/or objected to any

information contained in such reports. Action as deemed fit will be taken if the progress of the work is not satisfactory.

20.0 BANK GUARANTEE :

- 20.1 The Contractor in MAIN shall execute a Bank Guarantee to a specified value not less than **Rs.10.00 Lakhs** from any one of the Scheduled or Nationalized banks on behalf of the Contractor for the safe custody of the materials supplied by the BHEL, Ranipet as free issue and for the satisfactory performance of the Contracts. The guarantee shall be executed on a non-judicial stamp paper or value Rs. 100/- as per our standard Bank Guarantee clauses and shall be kept valid for the full contract period & Claim period of additional THREE MONTHS over the contract period and extensible till final settlement of supply and payment **and BG to be submitted directly by Bankers to BHEL in a Standard format as per Section XII. BG format will be given by BHEL and it has to be filled in that format only.**
- 20.2 In place of Bank guarantee, Fixed Deposit Receipt (FDR) drawn in favour of BHEL, Ranipet can also be furnished. In any case BG/FDR shall be available at the time of signing the contract.
- 20.3 The Bank Guarantee should cover the recoveries to be made by BHEL towards Safe custody of Material Supplied, Scrap / Faulty workmanship, etc. also for which proper material accounting is not made within the stipulated time and shall cover all Contracts past, present and future placed / to be placed by the BHEL, Ranipet. If the recovery amount is more than the pending bills, the difference amount to be settled immediately submitting Demand Draft in favour of BHEL/ Ranipet.
- 20.4 Loading on the vendor shall be restricted in such a way that the value of the materials to be issued and the stock of BHEL materials already available with the vendor.

21.0 BANK GUARANTEE NORMS;

- 21.1 Necessary Bank Guarantee (BG) / Fixed Deposit Receipt(FDR) should be furnished. The Bank Guarantee value applicable for the Firm is indicated in **Section XII** enclosed. The BG shall be kept **valid throughout the contract period PLUS 3 Months as claim period** and must be renewed in-time. It is also to be noted that the BG for the value indicated shall be made available with BHEL at the time of entering into ARC, failing which Firm will not be considered for entering in to contract with BHEL.
- The required Bank Guarantee shall be submitted within 15 Days of finalization of the contract, else the non submission of BG will be treated as "*not honoring his own offer or any of the condition*" stated/agreed in the tender and declared fit for taking penal action by BHEL as per "*Suspension of Business dealings vide Clause S of section IV*"
- 21.2 The release of Contract by BHEL, Ranipet shall be on the strength of Bank Guarantee for the safe custody of raw materials issued by BHEL, Ranipet as free issue in line with **CL. 20.1.**
- 21.3 Based on the capacity declared by the firm, the Sub-contractor may decide the maximum BG value over the base BG value, and the same shall be submitted to BHEL before ordering.
- 21.4 **BG shall be given by bidders for 100% of value of materials** to be issued to the vendor against Job Work Order. The value of materials shall be as per BHEL calculation, which is final.
- 21.5 JWO / Loading on the vendor shall be restricted in such a way that the value of the materials to be issued and the stock of BHEL materials already available with the vendor together do not exceed the value of BG at any point of time.
- 21.6 BHEL reserves the right to increase the value of BG/FDR depending on the material availability with the contractors from time to time. For placement of PO/addendum, if available BG is short of the required BG value, the same will be intimated to the vendor to submit additional BG. The vendor shall arrange for the required BG within 15 days from the date of receiving such intimation from BHEL. If the vendor does not submit the required BG within 15 days,

then the loading quantity may be reduced / diverted to other firms. After completion of that particular order, the vendors can request for return of BG (other than base BG) and the same shall be considered by BHEL.

- 21.7 The base BG shall be returned by BHEL after 90 days from the date of final bill submission or ARC validity period whichever is later.

22.0 GUARANTEE OF FABRICATION / MACHINING:

The Contractor shall warrant that the conversion work comply fully with the drawings and other technical conditions. If the jobs are found defective owing to reasons attributable to the vendors like faulty workmanship / incomplete work within a period of eighteen months from the date of handing over to BHEL, the Contractor shall make good of it / replace the same free of cost. Alternatively, the rework / replacement charges will be recovered from the Contractor.

23.0 LIQUIDATED DAMAGES and RISK PURCHASE:

- 23.1 The semi-finished jobs/fabrications on acceptance by BHEL, Ranipet inspector or by their authorized inspection agency, shall have to be delivered to BHEL, Ranipet Stores / Finishing Bay immediately on or before the delivery date stipulated in the addendum. Where the Contractor supplied the finished machining / fabrications beyond the delivery date stipulated in the addendum, liquidated damages at the rate of **1/2%** of the value (Conversion Cost) of the assemblies delayed for each week or part thereof will be levied subject to a maximum of **10%** value of the particular Work Order in the addendum to the Contract without prejudice to any other relief or compensation to the BHEL, Ranipet under any other conditions of the Contract.
- 23.2 Further, BHEL, Ranipet will get these items fabricated elsewhere, without notice to the Contractor on the account and at the cost and risk of the Contractor, the jobs not so delivered without canceling the Contract in respect of installments of machining / fabrications not yet due for delivery or cancel the Contract or a portion thereof and, if so desired, fabricate elsewhere at the cost and risk and account of the Contractor. Any additional expenditure incurred by BHEL on this account shall be recovered from the Contractor.
- 23.3 In general, delivery period for each JWO shall be 3 Months from JWO Date/Last material clearance date including further materials, whichever is later. However actual delivery shall be fixed by BHEL for each JWO on project requirement and product lead time.
- 23.4 Where delivery extension is sought with waiver of penalty, the same should be applied to OS with justification and approval to be obtained before delivery to BHEL Stores/Shipping and two copies of such letters (One for Accounts & One for OS Department) are to be enclosed along with all the bills. Failure to comply with this requirement will result in recovery of penalty while processing the bills for payment as stated in **Cl. 23.1** from the same bill and no claims for refund of liquidated damages will be entertained there after.
- 23.5 Reasons like power cut, Labour Issue, Machine Break-down etc., which are controllable by the vendors shall not be accepted as reasons for delay for delivery extension purposes. No compensation shall be given to the Contractors, in case of cancellation/diversion of PO'S beyond the delivery Due Date, even if the Jobs have been processed partly.

24.0 ACTION AND COMPENSATION IN CASE OF BAD WORKMANSHIP:

If any work has been executed with unsound, imperfect or bad workmanship or with materials of inferior quality, the Contractor shall on demand in writing from BHEL specifying the work, material/articles complained of, notwithstanding that the same may have been passed, certified and paid for, forthwith, rectify the work so specified in whole or in part as the case may require, at their own cost and in the event of his failure to do so within reasonable period. BHEL will rectify or remove and re-execute the work at the risk and expense of the Contractor.

25.0 COMPENSATION AGAINST DAMAGE OF MACHINERY/TOOLS AND GAUGES SUPPLIED:

- 25.1 BHEL reserves the right to claim adequate compensation from the Contractor on account of any damage caused to the machinery / equipment / tools and gauges supplied to them for execution of work, due to careless or faulty handling or negligence on the part of the Contractor. The total cost of recovery will be decided by BHEL.
- 25.2 BHEL shall have general supervision and direction over the work, BHEL has the authority to stop the work, whenever such stoppage may be necessary to ensure the proper execution of the Contract. BHEL shall also have the authority to reject all the works which do not conform to the specification, to direct the application of forces to any portion of the work as, in their judgment is required, and order the force increase or decrease and to decide on the issues which arise in the execution of the work.
- 25.3 BHEL reserves the right to suspend the work or part thereof put a hold on further loading to the Contractor at any time for any reason at its discretion and no claim whatsoever on this account will be entertained.

26.0 SUBLETTING :

- 26.1 The Contractor shall not sublet or assign this Contract or any part thereof without the written permission of BHEL, RANIPET. Subletting or assigning this Contract or any part thereof without such permission BHEL, Ranipet shall be entitled to cancel the Contract and to execute the conversion work elsewhere at the risk and cost of the Contractor and the Contractor shall be liable for any loss or damage which BHEL, Ranipet may sustain in consequence of or arising out of such machining / fabrication elsewhere and also cancellation of registration/temporary suspension of further loading.
- 26.2 However, if the PO/PGMA loading demands part processing / Special Process (like Heat Treatment, Machining, Bending, Shearing, Threading, etc..) of certain items at, other BHEL OS-approved Contractor's works, the same may be allowed with the prior permission of BHEL in writing, indicating the period of returning.
- 26.3 "Movement of BHEL materials from our Contractor's premises to any other Firm(s), if necessary, for the purpose of production related work shall be documented properly, signed by the sender & receiver and the same to be authenticated by the concerned OS official, otherwise such materials will be treated as shortage by Accounts".
- 26.4 The vendors will be allowed to indicate alternate sources for carrying out these intermediate operation, wherein the said other sources shall seek approval from BHEL for carrying out these operations.
- 26.5 These intermediate operations are to be carried out only at the approved sources and addition/deletion to this list will be indicated to the vendors then and there.

27.0 TAXES & DUTIES-GST:

- 27.1.1 Taxes and duties as applicable from time to time, shall be paid extra over the quoted rates. (as per latest GST guidelines)
- 27.1.2 Vendors should provide a valid GST registration number and the same should be clearly mentioned in the offer. If any specific exemption is available, a declaration with due supporting documents need to be furnished for considering the offer. Vendor should get themselves registered and obtain a valid GST registration number as per the GST guidelines
- 27.1.3 In case any changes in GST guidelines as per Gov. Notification , the same shall be applicable from time to time.
- 27.2 Taxes applicable if any will be reimbursed at actual on submission of necessary tax invoice mentioning the GSTN registration number and proof of payment to the statutory authorities.

- 27.3 BHEL will recover applicable GST along with cost of prime material, off cut, scrap including Turning & Boring (T and B) as per clause 5.1 at the time of finalizing MAS wherever the property in the goods passed on to the Contractor. An Invoice will be issued under relevant rules of GST.
- 27.3.1 Wherever GST is claimed by Contractor as above BHEL shall reimburse the applicable GST presently @ 18% against submission of the following documents:-
- i. GST Registration Certificate
 - ii. Original Tax Invoice (as per GST Rules)
 - iii. Certificate for payment of GST
 - iv. Abstract of GSTR-I & GSTR-3B or any other returns as prescribed from time to time
- 27.3.2 In case BHEL is not able to get input Tax credit (ITC) for the payment made by vendor for any of the reason attributable to vendor , the same shall not be reimbursed/recovered from the bills/claims of the vendor (if reimbursed)
- 27.4 GST TDS deduction at such percentage as prescribed under GST Law from time to time will be made on the value of invoices
- 27.5 Income Tax deduction and surcharge on IT at source at such percentage as prescribed in the Income Tax Act from time to time will be made on the value of the invoices in the absence of Income Tax Exemption Certificate from the concerned Income Tax Officer received and submitted by the Contractor. Contractor has to submit photocopy of PAN Card along with original for verification.
- 27.6** All statutory documents required for execution of contract to be finalized against this enquiry and required from time to time by State/central Govt. Authorities shall be submitted to BHEL, failing which appropriate recovery/actions as deemed fit will be levied from the running bills of the contractor.
- 27.7 Contractors are exempted from payment of GST as they are job workers as prescribed under Section 143(1) of GST Law as amended from time to time for the purpose of free issue of raw materials/semi finished goods to them for carrying out necessary operation and return the finished components without payment of duty to the BHEL RANIPET's factory for further processing. This is subject to subsequent statutory modifications and amendments in force from time to time. Contractors shall comply with the requirements of the said Section and also rules made under GST LAW . This is subject to subsequent statutory modifications and amendments in force from time to time. Besides, Taxes, duties, levies and any other govt. special levies as applicable from time to time, through notifications/amendments to original notification/orders, during the tenure of the rate contract, shall be extra as applicable against valid documentary evidence. Any increase or decrease in this regard will be effected accordingly against valid documentary evidence.
- 27.8 The required raw materials will be issued under the cover of Delivery challan as prescribed under GST Law. The Contractor receiving the materials under above said challan (2 Copies) have to complete the work order and return the finished components and scrap under the cover delivery challan issued by BHEL within 3 months from the date of first issue of materials unless otherwise extended by BHEL and all materials shall be fully accounted for in FMAS. For this purpose Duplicate (ONE) copy of all the Challan shall be returned back to BHEL after duly signing in with seal with FMAS and DC copy. If the materials are not returned/ fully accounted for within three months or such extended period as may be allowed by BHEL, any financial implication on BHEL will be recovered from the Contractor's bills.

- (i) In case of failure of non submission of challan due to reasons not attributable to Contractor, (like non matching of materials, hold informed by BHEL, delay due to cycle time etc.,) is to be intimated to BHEL every month by the Contractor.
- (ii) Incase of direct dispatch to customer site (or) returning of material back to BHEL store, necessary GST formalities have to be complied with by Contractor and also necessary records as per GST Law have to be maintained by the Contractor.
- (iii) FMAS is to be prepared immediately on dispatch in all cases based on which applicable GST on scrap/Off cut will be recovered from Contractor and paid to GST Dept.
- (iv) BHEL, RANIPET will not be responsible for payment of any taxes and duties wrongly paid on account of ignorance of law or otherwise and also duty paid at a later date based on litigation.

28.0 GENERAL :

- (a) BHEL reserves the right to recover the dues if any, from the contractor from any one of the running bills of this contract or any other contract with the contractor or from any other division of BHEL. Vendors disqualify themselves to be an approved vendor of BHEL, in the event , it is found that they carryout activities / business which are in direct competition to BHEL business and accordingly they will be delisted. Vendors / Firms indulging in business practices detrimental to BHEL, will be severely dealt with by the due process of law. In addition to the above conditions the following specific conditions also bound under this contract.
- (b) It is preferred that the Proprietor/Managing Partner/Director as applicable to the company should be easily accessible to BHEL official for day to day interaction and to have the residence within 30 KM from BHEL/BAP for the firms located in and around Ranipet. Any change in the constitution of the Contractor's unit or in shifting of works to a new location, the same shall be made only after getting specific approval from Outsourcing BHEL RANIPET. Any deviation found later will be dealt with as deemed fit including cancellation of registration. Also change of Banker requires the prior approval of BHEL, Ranipet.
- (c) Partnership firms should have the latest Form A (Rule 5) Declaration filed with the Registrar of Firms and private Limited firms should have the current MOA and the copy of the same should be produced at the time of signing the Contract.
- (d) The Contractor is liable for all statutory obligations, including but not limited to taxes and duties, ESI, PF, ED/ST, Labour Acts, Factories Acts, Workmen Compensation Act, etc., for their workers. BHEL, RANIPET will have no liability in respect thereof. Notwithstanding the above, if any demand notice is served by the concerned Statutory authorities for recovery of any of their dues on BHEL, BHEL shall have the right to pay the same without notice to the Contractor and recover the same plus administrative charges of 15% of such amount from the Contractor either from the pending/future bills of the Contractor or otherwise. Such act of repeated default is liable for suspension/stoppage of further business till such time the default/violations get vacated. Notwithstanding anything to the contrary, BHEL shall not be liable for any penalty or interest imposed by any statutory authority due to the action of the Contractor or his employees, workers, agents, etc. .
- (e) The Contractor has to devise suitable scheme whereby the employment of child labour should be regulated in line with the child Labour Act (prohibition and Employment Act 1986).
- (f) All the safety precautions and use of safety equipments are to be followed while carrying out the fabrication and despatch of the same. The Contractor must have proper tools and handling equipments. There should always be a responsible person available at the Contractor's works to oversee the operation and compliance of safety regulations. If any non-compliance with respect to proper safety conditions/requirements, BHEL may withhold visit/inspection, instruct stoppage of work till such time the desired safety requirements/conditions are met with.
- (g) All the documents (Inclusive of Drawings, GMS and Standards) of BHEL made available to the Contractor should be kept in a strict confidence and under no circumstance be made available to others or allow others to make use of them for any other commercial purpose whatsoever.

This secrecy clause is binding on the employees of the Contractors also. Any contravention will be subjected to legal action besides suspending business with BHEL. Such documents should be returned to the BHEL, RANIPET destroyed with the prior approval of Outsourcing, BHEL, RANIPET.

- (h) Unauthorized act of engagement of any individual who is a full time employee of BHEL for part time/full time work by the Contractor will be viewed very seriously and such act is liable for suspension/total stoppage of further business dealings with the Contractor by BHEL, RANIPET.
- (i) Should a Contractor has a relation or relations in the case of a firm or a company of the Contractor, one or more of its shareholders or relation or relations of the shareholders employed in BHEL or any ex employee who has retired/resigned within a period of two years as on date of the Contract or at any subsequent date after award of this contract, BHEL shall be informed of the fact at the time of signing the contract and thereafter as applicable and obtain the permission of BHEL for such engagement, failing which BHEL may in its own discretion rescind the contract.
- (j) The Contractor shall not attempt any unethical acts and if they are found indulging in such acts, they are liable to be blacklisted apart from other actions. Contractors indulging in any business practices detrimental to BHEL either directly or Indirectly, will be dealt with severely by the due process of law.
- (k) In case of any internal dispute of the Contractor, such as but not limited to disputes between partners of the Contractor, dispute between Contractor and its employees, the same shall be intimated to BHEL within One Month from the date of dispute. Notwithstanding anything to the contrary, BHEL shall not be made a party any suit or legal proceeding in respect of such internal dispute. In case BHEL is made a party to the same, the Contractor and other party(ies) to the dispute, if signatories to this Agreement, shall indemnify BHEL for (a) all direct and indirect costs expended towards such legal proceedings immediately on the issue of a claim notice to that effect from BHEL and (b) any liability that may be imposed in such legal proceedings against BHEL.
- (l) Payment for all the invoices shall be effected by a crossed A/C payee cheque /EFT/RTGS in favor of the Banker which should be indicated in all invoices of the Contractor.
- (m) In order to ensure safe custody of our materials, leasee of those firms under lease shall ensure that their lease period is valid for minimum of 3 years (from date of signing the contract).
- (n) In addition to the above, our standard General Conditions enclosed shall also apply.
- (o) The entire terms and Conditions contained in this tender shall be deemed to form an integral part of the Contract to be entered.

29.0 BHEL reserves the right to :

- (a) Negotiate with the Contractor who has submitted the Lowest offer for "Payment Rate Schedules" and Highest offer for "Recovery Rate Schedules"
- (b) Distribute the requirements on more than one contractor at the Lowest (for Payment RS) / Highest (for Recovery RS) acceptable rate.
- (c) The rates and other terms and conditions in this contract are applicable for the job work orders likely to be placed by other Departments/Units of BHEL also, for similar items.

30.0 Primary e-Mail-ID: Contractors are requested to indicate their own email-Id as "Primary e-Mail-ID", which will only be used for all correspondences (like for MAS and Payment etc..)

31.0 Arbitration and Jurisdiction:

- (a) Any dispute between BHEL and the Contractor arising out of or in connection with this Contract, other than those for which BHEL decision is final, shall be referred to arbitration by a sole arbitrator.
- (b) The parties hereto agree that the Sole Arbitrator shall be the Unit Head of BHEL, BAP, Ranipet or his nominee. The venue of Arbitration shall be Ranipet, Tamil Nadu. The arbitrator may hold meetings for convenience at such places as per his discretion.
- (c) The award of the Arbitrator shall be final, conclusive and binding on both parties to the Contract.
- (d) Subject to the above, the courts at Ranipet alone have the jurisdiction to decide any dispute arising out of or in respect of the Contract.

Vendors are requested to quote only for the Rate Schedules **(54AA)** as per the Technical Bid and Price Bid hosted.

The offers should be submitted as detailed in **Section I to Section XII and Annexures A to K**

BHEL, Ranipet is not responsible for any type of delay in receipt of tender.

BHEL, Ranipet reserves the right to reject any or all the tenders either in full or part thereof at their discretion without assigning any reason thereof.

Thanking you,

Yours truly,

For and on behalf of
BHARAT HEAVY ELECTRICALS LIMITED,

MANAGER (CONTRACTS) / OS

	Bharat Heavy Electricals Limited (A Government of India Undertaking)		☎: 04172-284030, 284158, 241170
	Boiler Auxiliaries Plant, Ranipet – 632 406		
AN ISO 9000 COMPANY	OUTSOURCING DEPARTMENT		E-Mail : tenderoutsourcing@bhelrpt.co.in
Enquiry No	658014E	Due Date & Time for submission of offers	Prior to 09.45 Hrs On 09.10.2019
Enq-Dated	19.09.2019	Date & Time of Tender opening	By 10-00 Hrs On 09.10.2019
<u>SECTION III</u>			
Technical Description and Rate Schedules Classification			
ARC 2019-20 for OS- Main- 54AA Fabrication			

Scope of the enquiry is to finalise the Rates for entering into Annual Rate Contract for the year 2019-20 for Complete Manufacture of casing walls Hopper Walls, Roof Panels , Gable Top/middle/bottom ,insulator pannels etc from raw materials/components supplied from BHEL. Vendor scope includes collection of raw materials from BHEL (single/multiple) and delivery of finished goods to BHEL shipping . All the terms and conditions applicable for OS-MAIN-ARC 2018-19 shall be applied to this tender .

1.0 The Total Tonnage tentatively for this Rate Contract is 12800 MT.

The requirements are given in the form of Rate Schedule (RS). Rate Schedule contains Rate Schedule Number, Description of the scope of operation to be carried out Unit and Quantity Anticipated in **2019-20** for ordering.

2.0 Rate Schedule: Rate schedule **54AA** is given in the tender. For extra Rate Schedules there are **72** Rate Schedules available – Ref. **Section IIID.**

3.0 Extra Rate schedule: Extra works if any carried out as per drawing / QWI / JWO requirement shall qualify for extra payment, as per extra rate schedule listed in **Section IIID.**

Note: For reference purpose, the current running ARC rates for extra Rate schedule are indicated in Section IIID. Tender already floated for finalizing new extra rates for RS E44,E45 & E46 and the same will be applicable for this tender also.

4.0 Recovery Rate Schedules: The Rate Schedules E41, E42, E43 and E73 are the recovery Rate Schedules given under EXTRA RS Group in Section IIID.

5.0 Scope of the Operation : Complete Manufacture as per Drawing. The Rate Schedule contains descriptive details of items only. However, during actual release of orders, specific Drawing will be given for manufacturing.

6.0 Mandatory and General Facilities Required : To carry out the operations required on the job for the concerned Rate Schedule, the manufacturing Facilities required like Welding Machines, Presses, Shearing Machines, Measuring Instruments etc. are mentioned against Rate Schedule in **Annexure-FH**.

7.0 Eligibility of Vendors : The vendors who are all having the Facilities required, mentioned against Rate Schedules in **Annexure – FH** can quote for the Rate Schedule.

8.0 Distance Eligibility Criteria- Vendors Location.

Vendors located within the radius of 350 KM from BHEL, Ranipet are only eligible for this tender.

9.0 Quantity : Tentative annual requirement is mentioned against Rate Schedule in the Tender- Technical Bid. This quantity may vary during the currency of the contract according to the receipt of orders by BHEL.

10.0 Technical Bid : Technical specification Document for Rate Schedule is available in the Technical Bid,

Existing Vendors who are all executing jobs in the running MAIN-ARC has to mention completed PO/IP number released in MAIN ARC 2014-15 against Rate Schedule choose for quoting.

11.0 Price Bid : Price Bid to be submitted through EPS only and not as any attachment in the technical bid.

Note: Unit rate only to be mentioned in the price bid. Any Rate indicated other than in Price Bid Part III shall not be considered.

12.0 Drawings : Rate Schedule relates to a group of drawings / PGMAs consisting of similar nature and content of work. List of Drawings are given in **Section V** for reference purpose.

Due to large number, volume, the drawings are not hosted in the Web-Site. Similar Sketches hosted in the web site are detailing the work content of these drawings. Vendors can view the original Drawings at OS department.

The drawings will be displayed at BHEL for the Vendors who are willing to quote for the Rate Schedule. Drawings available for study purpose to the Vendors at BHEL Outsourcing Department, conference hall from 09.00 Hrs to 16.00 Hrs on all working days from Monday to Saturday till 3 days before the tender opening due date.

Hence it is suggested that, the Vendors has to visit BHEL to study the drawings along with their Technically competent officials to study the operations involved, facilities required and to estimate the cost of operations for quoting.

The fabrication rates are to be quoted based on sketches/drawings indicated.

16.0 Quality Documents: Relevant Quality Work Instructions (QWI), Procedure of Quality Assurance (PR:QA), Welding Procedure Specification (WPS) specified in the Rate Schedule / Drawings are given in **Section X**.

Care: Offers received other than the format hosted in the web site will be summarily rejected. Vendor has to study carefully all the technical requirements before quoting for the Rate Schedules.

RSNO	RATE SCHEDULE DESCRIPTION	UN	RATE
E01	CONVERSION CHARGES FOR FLAT OUT OF PLATES .	MT	55.00
E03	MAGNETIC PARTICLE INSPECTION/TESTING [MPI].	MR	30.00
E04	RADIOGRAPHY [RT]	MR	677.00
E07X	DEDUCTION OF TRANSPORT CHAGES FOR DTS 0 TO 100 KMS	MT	750.00
E07Y	DEDUCTION OF TRANSPORT CHAGES FOR DTS 101 TO 350 KMS	MT	850.00
E07Z	DEDUCTION OF TRANSPORT CHAGES FOR DTS 351 TO 450	MT	950.00
E08	SURFACE PREPARATION EQUAL TO SHOT BLASTING.	SM	74.50
E100	JOINTS OF Stainless Steel PLATES 5 mm TO 10 MM/RM	MR	340.00
E101	Addition charges for blast cleaning up to Sa 2	SM	65.00
E102	Painting - Zinc phosphate primer - grey shade 35 microns	SM	44.00
E11	25 MIC OF EPOXYZINC RICH PRIMER [EXCEPT WM XXX]	SM	80.00
E13	25 MIC OF EPOXY ZINC PHOSPHATE PRIMER	SM	62.00
E14	40 MIC OF WHITE ENAMEL PAINT	SM	49.00
E16	25 MIC OF HEAT RESISTANT BLACK BITUMINOUS PAINT TO IS-158	SM	22.00
E17A	TRANSPORT CHARGES FOR TO AND FRO MOVEMENT OF SEMI-FINISHED COMPONENTS FROM YOUR WORKS TO THE WORKS OF CONTRACTOR SITUATED WITH IN 60 KMS FROM YOUR WORKS DOING THE INTERMITTENT OPERATION SUCH AS GALVANIZING/BLAST CLEANING/BALANCING/HEAT-TREATMENT/OTHER SPECIFIC OPERATION ETC AS PER ENQUIRY.	MT	500.00
E17B	TRANSPORT CHARGES FOR TO AND FRO MOVEMENT OF SEMI-FINISHED COMPONENTS FROM YOUR WORKS TO THE WORKS OF CONTRACTOR SITUATED BETWEEN 61 KMS AND 160 KMS FROM YOUR WORKS DOING THE INTERMITTENT OPERATION SUCH AS GALVANIZING/BLAST CLEANING/BALANCING/HEAT-TREATMENT/OTHER SPECIFIC OPERATION ETC AS PER ENQUIRY	MT	1001.00
E17C	TRANSPORT CHARGES FOR TO AND FRO MOVEMENT OF SEMI-FINISHED COMPONENTS FROM YOUR WORKS TO THE WORKS OF CONTRACTOR SITUATED BETWEEN 161 KMS AND 350 KMS FROM YOUR WORKS DOING THE INTERMITTENT OPERATION SUCH AS GALVANIZING/BLAST CLEANING/BALANCING/HEAT-TREATMENT/OTHER SPECIFIC OPERATION ETC AS PER ENQUIRY	MT	2200.00
E18	40 MIC OF HIGH BUILD CHLORINATED RUBBER ZINCPHOSPHATE PRIMER.	SM	65.00
E19	5 MIC OF ETCH PRIMER/WASH PRIMER	SM	55.00
E20	20 MIC OF SYNTHETIC ENAMEL LONG OIL ALKYD TOIS-2932 [SMOKE GREY]	SM	28.00
E23	25 MIC RED OXIDE ZINC CHROME PRIMER TO IS 2074/RUST PREVENTIVE OIL.	SM	10.00
E24	20 MIC BLACK ENAMEL PAINT TO IS - 2932	SM	29.00
E27	50 MIC HIGH BUILD EPOXY PAINT DARK GREY.	SM	66.00
E28	30 MIC EPOXY FINISH PAINT LIGHT GREY	SM	55.00
E29	75 MIC INORGANIC ZINC SILICATE PRIMER	SM	72.00
E30	30 MIC CHLOROKOTE ZINC PHOSPHATE TO IS 8632.	SM	29.00
E40	TRIAL ASSY OF TOTAL INLET/OUTLET FUNNEL ASSY[PYRAMID SHAPE] COLUMNS, LONGITUDINAL ROOF BEAMS, TRUSSES (X55), SPIRALCASINGS, TURBINE HALL STRUCTURES, DUCTS ,SILENCERS (ASSEMBLED FROM MULTIPLE BLOCKS), BRACKETS IN X25, SUCTION HOOD OF FANS AND ROOF ASSEMBLY OF FANS ETC.	MT	725.00
E41	RECOVERY RATE FOR CS/AS, ASBESTOS , WOOL , CAF SCRAP ETC.	MT	19000.00
E42	BIG SIZE SCRAP [CS/AS SHEETS/ PLATES]	MT	23000.00
E43	RECOVERY RATE FOR STAINLESS STEEL [NON-MAGNETIC], NON-FERROUS METAL SCRAP.	MT	95000.00
E51	HR ALUMINIUM PAINT [20 MIC] [UP TO 200 DEGREE C] IS 13183 / 1991 GRADE - III	SM	29.00
E52	HR ALUMINIUM PAINT [20 MIC] [ABOVE 200 DEGREE C] C]IS 13183 / 1991 GRADE - II	SM	50.00
E54	HR CHIMNEY BLACK PAINT [>250 DEGREE C] / FERROTOL BLACK CHIMNEY [50 MIC]	SM	50.00
E55	EPOXY HB MIO INTERCOAT [125 MIC]	SM	55.00
E56	ALIPHATIC PU FINISH OR EQVT. [75 MIC]	SM	82.00
E57	CHLORINATED RUBBER FINISH PAINT DARK GREY [40 MIC]	SM	61.00
E59	ETHYL ZINC SILICATE/ZINC DUST ETHYL SILICATE[75 MIC]	SM	64.00
E60	HB EPOXY ZINC RICH PRIMER [50 MIC]	SM	64.00
E61	CHLORINATED RUBBER BASED TITANIUM OXIDE PIGMENTED INTERMEDIATE PAINT [WHITE] - [50 MIC]	SM	110.00
E62	EPOXY RESIN BASED TWO PACK, TITANIUM OXIDEPIGMENTED INTER- MEDIATE PAINT [WHITE] -[100 MIC]	SM	45.00
E63	ZINC CHROME PRIMER IS104 40 MICRONS	SM	24.00
E64	RED OXIDE ZINC PHOSPHATE PRIMER 80 MICRONS	SM	37.00
E65	UT OF WELD,BUTT JOINTS OR FILLET WELDS OF COLUMN BASE [ALL WELDS] THICKNESS 12 TO 32MM ASPER AWS D.1.1	MR	48.00
E68	LABOUR COST FOR ONE COAT OF PAINTING. [PAINT- BHSL SUPPLY].	SM	5.00
E69	SYNTHETIC ENAMEL TO IS 2932 GREY SHADE RAL 9002 [20 MICRONS].	SM	30.00

RSNO	RATE SCHEDULE DESCRIPTION	UN	RATE
E71	ULTRASONIC TESTING [UT] OF PLATES / STRUCTURALS	SM	33.00
E72	CONVERSION CHARGES FOR EXPORT PACKING [FOR FINISHED COMPONENT WEIGHT [DU WEIGHT]]	MT	1113.00
E73	RECOVERY RATE FOR STAINLESS STEEL [MAGNETIC] SCRAP	MT	50100.00
E76	CONVERSION CHARGES FOR STRUCTURALS TO STRUCTURALS	MT	1155.00
E77	JOINTS OF CS/ HIGH TENSILE PLATES UPTO 4 MM/RM	MR	55.00
E78	JOINTS OF CS/HIGH TENSILE PLATES 5MM TO 10 MM/RM	MR	175.00
E79	JOINTS OF PLATES 12 TO 20 MM /RM	MR	290.00
E80	JOINTS OF BEAM/CHANNEL UPTO 200 MM /JT.	NO	95.00
E81	JOINTS OF BEAM/CHANNEL 201MM - 300 MM /JT.	NO	116.00
E82	JOINTS OF BEAM/CHANNEL 301- 450 MM /JT.	NO	149.00
E83	JOINTS OF ANGLES UPTO 75X75X8	NO	42.00
E84	JOINTS OF ANGLES ABOVE 75X75X8 UPTO 100X100X12	NO	78.00
E85	JOINTS OF ANGLES ABOVE 100X100X12	NO	110.00
E86	JOINTS IN BEAM /CHANNEL ABOVE 450 MM	NO	291.00
E87	ADDITIONA JOINTS FOR PLATES 21-25 MM/RM	MR	575.00
E88	ADDITIONAL JOINTS FOR PLATES 26-32MM/RM	MR	665.00
E89	ADDITIONAL JOINTS FOR PLATES 33-36 MM /RM	MR	895.00
E90	ADDITIONAL JOINTS FOR PLATES 37-40 MM/RM	MR	980.00
E91	ADDITIONAL JOINTS FOR PLATES 41 - 50 MM /RM	MR	880.00
E92	ADDITIONAL JOINTS FOR PLATES 51-56 MM /RM	MR	1001.00
E93	ADDITIONAL JOINTS FOR PLATES 57 MM AND ABOVE/RM	MR	1600.00
E94	CHLORINATED RUBBER PAINT (RAL)- 40 MICRONS	SM	35.00
E95	TESTING CHARGES OF GATE ASSEMBLY ELECTRICALLY OPERATED UPTO 7 MT	NO	5000.00
E96	TESTING CHARGES OF GATE ASSY ELECTRICALLY OPERATED ABOVE 7 AND UPTO 10 MT.	NO	6000.00
E97	TESTING CHARGES OF GATE ASY ELECTRICALLY OPERATED ABOVE 10 MT.	NO	10800.00
E98	EXTRA CHARGES PAYABLE FOR FIXING OF BULB SEALS (BULB SEALS ISSUED AS FREE BY BHEL AND APPLICABLE FOR GATE ASSEMBLIES LOADED UNDER RS-NO 117E, 117F, 117G, 118B, 118C, 119A)	MT	27000.00
E99	JOINTS OF Stainless Steel PLATES UPTO 4 MM/RM	MR	145.00



Enquiry Number: 658014E

Dt.16.09.2019

SECTION IV

GENERAL TERMS & CONDITIONS OF THE TENDER

(FOR GUIDANCE TO THE SUPPLIERS)

Before preparing the offer, vendors are requested to go through the following details carefully

A] Vendor Classification

Vendors to this tender are classified as " MAIN".

MAIN Vendor:

Vendors who are having manufacturing facilities for fabrication/machining with minimum 1.0 Acre Land in single location within the radius of 350 KM from BHEL, Ranipet.

B] Eligibility of Vendors to Quote:

Firms who are having sufficient manufacturing facilities and experience in manufacturing of similar Fabrication / Machining of jobs for Boiler Auxiliaries components like Hopper Walls of without corner welding, Bunker Assembly Bunker Walls, Cable Top, ESP Casing Walls, Roof Panels Assembly without Coller, Insulator Supporting Panels, Brackets etc.. and able to meet Eligibility Criteria (Facility Requirement) mentioned against Rate Schedule can quote for this tender.

Firms already registered with Outsourcing (OS) BHEL/BAP/Ranipet shall indicate vendor code in their offer and indicate PO/IP number if available. If vendor is new, then mention as "New" in the space provided for Vendor Code.

Vendors registered with any unit of BHEL for the similar jobs, shall give details of their registration along with the category registered for.

i) Evaluation Methodology For Eligibility Criteria :

- a. The Techno Commercial bids submitted by the firm will be scrutinized. The eligibility of the firms will be verified based on the pre-qualification criteria of the tender and compliance / confirmation to the tender requirements Rate Schedules by BHEL vendor evaluation team including spot verification if necessary for approval. Only those firms complying with the pre-qualification criteria shall be considered for participation in the tender.
- b. Once the vendor is found to be technically suitable meeting all the technical and commercial requirements of BHEL, price bid of those qualified vendors only will be considered for further processing.
- c. New vendor shall submit **Filled-in Vendor Registration form as in Annexure-K separately in hard copy for Vendor Development Cell (VDC).**

d. Submission of Annexure-K - Vendor Registration form is not pre-requisite for opening the price bid of the technically qualified vendor.

Note:

- (i) The facilities indicated in the RS should be available in working condition as on date at the time of submission of offer and to be made available for the whole contract period. Vendors shall not quote for the ranges-which are beyond their manufacturing capacity.



(ii) Firm Land shall be owned either by the partners/ proprietor or registered in the name of the firm. In case of Leased land, the lease agreement shall be registered in the name of either by the partners/ proprietor or registered in the name of the firm and valid for a minimum period of 3 years from the date of Tender Opening. Self attested Copy of Lease agreement / own land document to be enclosed along with the tender.

C] Vendors Not Eligible to Quote

Vendors declared / notified as defaulters / poor performers on quality / delivery grounds are not eligible to quote. The vendors with whom the material shortages were found during stock verification and not settled at the time of tender opening will not be considered. Offers if any received such vendors shall not be considered.

Vendors under HOLD by BHEL are not eligible for such RS and vendor delisted/banned are not eligible for whole tender.

Vendors who have quoted in Open Tender for **2018-19 ARC** in MAIN or LDPP, ranked L1 rate in any of the Rate Schedules and not signed the Annual Rate Contract **2018-19** are not eligible to quote for this tender.

D] Distance Criteria for the New Firms

vendors located within the radius of 350 KM from BHEL, Ranipet are eligible to quote

E] EMD (Earnest Money Deposit)

(Copy of the DD/Payment receipt is to be uploaded in the system)

Non MSE Vendors has to submit EMD for Rs. 2.00 Lakh in the form of Demand Draft favouring “Bharat Heavy Electricals Ltd., Ranipet – 632 406” payable at Ranipet,

(i) No interest shall be payable by BHEL on Earnest Money Deposit (EMD).

(ii) EMD will be forfeited if

a) The Tenderer withdraws his Tender within the validity period,

b) After becoming L1, if the firm does not sign the contract or not submitting the required base BG within the specified period, the EMD will be forfeited.

(iii) The EMD submitted by the vendors will be returned within a month from the date of signing the contract.

F] Validity of Offer

Price validity shall be One Year from the date of finalisation of Annual Rate Contract; however the validity date of the offer is 180 days from the date of tender opening for ordering. (Note: If Supplier does not honour his own offer or any of its conditions within the validity period, penal action deemed fit as per **Cl."S"** of Section IV - Suspension of Business Dealings with vendors).

G] Submission of Offer

TENDERS

The Bids shall be submitted in three parts namely (i) Earnest Money Deposit (EMD) fee Cover/ Micro Small Medium Enterprises (MSME) EM-II valid certificate (ii) Techno Commercial Bid Cover and (iii) Price bid cover. All these Three covers should be sealed individually and to be put in a single envelope.

Sealed tenders super-scribed with Tender Number with date, Due Date, **ARC-54AA-2019-20** & Supplier's Name, Vendor Code/**Reference Code as "New"** for new vendor shall be addressed to Senior Manager / Contracts, Outsourcing Department, Bharat Heavy Electricals Limited, Ranipet – 632 406, Tamilnadu, India, so as to reach him on or before the date and time specified in the tender.



The bidders are requested to submit the bids with double stapled on the left middle of the papers, and tied with file tag. Bidders are also advised strictly not to submit the bids with spiral binding & hard book binding, as it will hamper the evaluation of the offers.

The details of contents of the offer covers are as under:-

Sealed Single Envelope super-scribed, with ARC-54AA-2019-20, Tender Number & Date, Tender Due Date, Vendor's Name & Vendor Code / Reference Code as "New" containing:

Cover I: EMD / MSME Requirements

Sealed Cover super-scribed "Cover I – EMD / MSME Requirements" with ARC-54AA- 2019-20, Tender Number & Date, Vendor's Name & Vendor Code / Reference Code as "New" containing:

- a) **Check list for Cover-I**
- b) **Earnest Money Deposit (EMD) Rs. 2.00 lakh** in the form of Demand Draft, as called for (for Non MSE supplier), **(OR)**
- c) **MSME documents** to avail exemption from submission of EMD: –
 - i. **Self Attested Copies of either EM II (Entrepreneur Memorandum Part II) having deemed validity Five years from the date of issue of acknowledgement in EM II from the date of acknowledgement of the EM II certificate (or)**
 - ii. **Valid NSIC Certificate (or)**
 - iii. **EM II Certificate along with attested copy of a CA Certificate (Format enclosed as Annexure-G where deemed validity of EM II certificate of five years has expired) applicable for the relevant financial year (latest audited).**

Date to be reckoned for determining the deemed validity will be the date of Tender opening. Non submission of such documents will lead to consideration of their bids at par with other bidders and MSE status of such suppliers shall be shifted to Non MSE supplier till the supplier submits these documents.

Note:

- (i) Cover I received without EMD or all Supporting MSE Documents as specified above will lead to rejection of the offer.
- (ii) The Cover II and the Cover III of such offers shall not be opened and they would not be considered for further evaluation.

Cover II: Qualifying Criteria, Techno-Commercial Bid

Sealed Cover super-scribed "Cover II – Qualifying Criteria Techno-Commercial Bid" with ARC-54AA MAIN 2019-20, Tender Number & Date, Vendor's Name & Vendor Code / Reference Code as "New" containing:

- a) **Check list for Cover-II (Annexure-B)**
- b) **Signed in Standard Commercial Terms & Conditions format** given as **Annexure-E.**,
- c) **Signed in Technical Bid** for each Group quoted in this tender (without Price) as per **Annexure-C.**
- d) **Signed in Section III D** for Extra Rate Schedule
- e) **Affidavit** in Stamp Paper value Rs.100 as per **Annexure-I**
- f) **Own land - Document copy / Lease Land – Self attested Copy of Registered Lease Agreement and Encumbrance Certificate covering past 20 years for Own/Lease land.**



- g) **Integrity Pact** as per **Annexure-H**
- h) **Documents to be enclosed for Partnership Firm –Self Attested Copies**
- i) Latest Form- A, issued after 01.04.2019.
 - ii) Partnership Deed Copy (AT WILL).
- i) **Documents to be enclosed for Limited Firm (Private Firm) – Self Attested Copies**
- i) Latest resolution by Board of Directors.
 - ii) Memorandum of Article of Association.
 - iii) Company's Affidavit for existence
 - iv) Latest Annual Report.
 - v) Directors Share details
- j) **Vendor Registration Form** given as **Annexure-K** along with all necessary documents (**For New Vendor**)
- k) **Eligibility Criteria format** given in **Annexure-FH**
- l) Vendor has to submit JWO/PO copies along with drawings/DC/IR and Bank transaction statement for the submitted Job Work Orders. All credentials will be verified by BHEL.
- m) Vendor has to submit Credit Limit facility for the value of Rs.20 Lakh obtained from the bank to verify the finance stability.
- n) Vendor has to submit previous year Income Tax Return copies (17-18)

Note:

- (i) All new firms shall submit vendor registration forms (**Annexure-K**) along with supporting documents.
 - (ii) Price bids of firms failing to meet the Technical Qualification / Eligibility Criteria of the quoted Rate Schedules shall not be considered for further processing in the tender.
 - (iii) Rates shall not be indicated anywhere in the Technical Bid.
 - (iv) All Annexure to the Techno-Commercial bid should be serially numbered.
 - (v) Tenders not submitted in the prescribed formats given in the Annexures like Standard *Commercial Terms & Conditions*, *Technical Bid*, etc. and *incomplete offers* are liable for rejection.
- vi) Documents shall be annexed in the order specified above (clause a to k of cover-II)**

Cover-III : Price Bid

Sealed Cover super-scribed "Cover III – Price Bid" with ARC-54AA MAIN 2019-20, Tender Number & Date, Vendor's Name & Vendor Code / Reference Code as "New" containing:

Price Bid - Price duly filled-in the Price Bid format provided in the tender document as **Annexure-D** for each Rate Schedule / Rate Schedule Group in conformance with the commercial terms as per Cover-II

The Prices shall be indicated in both figures and words. Unit rate only to be mentioned in the price bid.

Any Rates indicated other than in Price Bid Cover III shall not be considered.

Note:

- i) The price should be on "FOR BHEL, Ranipet" basis only (Inclusive of packing, forwarding and freight charges). No other delivery terms shall be acceptable.



- ii) While quoting their rates, the Bidders are advised to take into account the likely expenditure, escalations, statutory requirements & levies, labour laws, safety requirements, taxes, etc during the operation of Rate Contract for one year from the date of award of Contract. No price escalation/variations shall be entertained during the ARC period on any account. The rates are operative for placement of orders for **ONE YEAR** on Rate Contract basis to be entered into between BHEL and the Contractor.
- iii) Tenderer shall bear all cost incidentals to preparation, submission and negotiations of the tender.
- iv) If BHEL withdraws the Tender before or after the receipt of offers, whether the offer is accepted or not, tenderer shall not be entitled to claim any costs, charges, expenses incidental or incurred by him through or in connection with the submission of the offer.
- v) In case, there is a discrepancy in the term quoted in techno-commercial bid and price bid, the term as per the techno-commercial bid (Cover II) shall hold good and the commercial term quoted in the Price Bid (Cover III) shall not be considered.
- vi) In their own interest, all Tenderers are advised to double check their prices before submitting the offer.
- vii) The quotation should be valid at least for a period of 180 days from the tender opening date.
- viii) Offers should be submitted One Set in original only.
- ix) The offers should invariably contain Signature (ink-signed) & Office Stamp of the Supplier. Any corrections / erasures in the offers should be initialled and stamped.
- x) Bidders should submit the prices in Indian Rupees only.

Important Note 1:

Vendors who have submitted the following documents for MAIN-OS-ARC-NIT_41347-658001E dt.29.09.2018 tender, need not submit the same again for this tender.

b) Affidavit (Annexure-I), c) Land Document including lease agreement, EC, e) Partnership firm Documents f) Private firm documents and g) Vendor Registration form Annexure-K.

Note 2:

(1) All new firms shall submit vendor registration forms (**Annexure-K**) along with supporting documents. Price bids of firms failing to meet the Technical Qualification / Eligibility Criteria of the quoted Rate Schedule shall not be considered for further processing in the tender.

(2) Money values shall not be indicated anywhere in the Technical Bid (Part II).

(3) Tenders not submitted in the prescribed formats given in the Annexures like *Standard Commercial Terms & Conditions, Technical Bid*, etc. and *incomplete offers* are liable for rejection.

(4) Documents shall be annexed in the order specified above (Clause a to h of Cover II)

(5) Technical acceptance of offer by BHEL shall be based on the evaluation of offer and the submitted documents.

H4) Part-III : Price Bid

Price Bid - Price bid to be submitted in **Annexure D** only and not as any attachment with technical bid.

Unit rate only to be mentioned in the price bid.

Any Rates indicated other than in Price Bid shall not be considered.



Note:

- i) The price should be on “FOR BHEL, Ranipet” basis only (Inclusive of packing, forwarding and freight charges). No other delivery terms shall be acceptable.
- ii) While quoting their rates, the Bidders are advised to take into account the likely expenditure, escalations, statutory requirements & levies, labour laws, safety requirements, taxes, etc during the operation of Rate Contract for one year from the date of award of Contract. No price escalation/variations shall be entertained during the ARC period on any account. The rates are operative for placement of orders for **ONE YEAR** on Rate Contract basis to be entered into between BHEL and the Contractor.
- iii) Tenderer shall bear all cost incidentals to preparation, submission and negotiations of the tender.
- iv) If BHEL withdraws the Tender before or after the receipt of offers, whether the offer is accepted or not, tenderer shall not be entitled to claim any costs, charges, expenses incidental or incurred by him through or in connection with the submission of the offer.
- v) In case, there is a discrepancy in the term quoted in techno-commercial bid and price bid, the term as per the techno-commercial bid shall hold good and the commercial term quoted in the Price Bid shall not be considered.
- vi) In their own interest, all Tenderers are advised to double check their prices before submitting the offer.
- vii) The quotation should be valid at least for a period of 180 days from the tender opening date.
- viii) Bidders should submit the prices in Indian Rupees only.

I] Opening of Offers

a) Tenders (Offers) shall be received upto 09.45 Hours (A.M) on the said due date and be opened on the same day at 10.00 Hours (A.M). Tenders received after 09.45 Hours (A.M) would not be opened. The times indicated are Indian Standard Time (IST).

b) It is bidder's responsibility to ensure that the Tenders are submitted before the specified date and time. BHEL shall not be responsible for any postal delay.

c) If a Supplier submits only one envelope / cover containing all the bids or combined bids e.g. EMD/MSME documents, techno-commercial bid & price bid together, the bid is liable for rejection. The decision to accept such bids shall be the sole discretion of BHEL, which may be done by BHEL after segregating the bids so received.

d) First Cover I containing EMD / MSME documents shall be opened, only if EMD as mentioned above OR the valid MSME certificate is available, the respective Cover II - Techno Commercial bid will be opened subsequently.

e) Price Bid opening will be done through Reverse Auction method (English method) **which will be decided after techno-commercial bid evaluation is completed.** All tenderers would have to specifically give their acceptance for this in their bid/s. The date / time of Price Bid opening will be communicated to the technically qualified Bidders separately.

f) Witnessing the Tender opening

i) Such of those Tenderers who wish so, may participate in the Tender Opening by deputing their representatives. The representatives would be allowed to participate in the Tender opening only on submission of a signed and stamped authorization letter issued by the Supplier as per **Annexure-L.** Representatives without the Authorization Letter would not be allowed to participate in the Tender Opening.



ii) Representatives who turn up after the Tender opening time / start of the Tender opening would not be allowed to participate. After tender opening the details would not be given to such suppliers who choose to be absent at the Tender opening.

iii) Authorizations received by fax / e-mail would not be acceptable.

iv) Details of the vendors participated alone would be read out during Technical Bid opening and details of Price alone would be read out during Price Bid opening by the Tender Opening Officer.

Note

(i) Bids including all enclosures and supporting documents like catalogues, pamphlets, etc., shall be provided in ENGLISH language only.

(ii) Offers sent by e-mail / fax or any other mode other than the three cover system specified above shall be avoided.

(iii) At its option, BHEL may consider extending the due date/s for the tender openings. Sufficient notice would be given by BHEL for such extensions.

J] Evaluation of Techno Commercial Offers

The Techno commercial bids submitted by the firm will be scrutinized. The eligibility of the firms will be verified based on the pre-qualification criteria of the tender and compliance / confirmation to the tender requirements for each Rate Schedules/ Group of Rate Schedules quoted. Only those firms complying with the pre-qualification criteria shall be considered for participation in the tender. Once the vendor is found to be technically suitable meeting all the technical and commercial requirements of BHEL, price bid of those qualified vendors for respective category only will be considered for further processing.

n) Offers of vendors not technically qualified will be rejected and the same will be communicated to the vendors with reasons.

o) No deviation or change from the Tender conditions will be allowed and BHEL reserves the right to reject such offers.

p) **Conditions for rejection of offers:**

Following is the list of situations which would lead to rejection of offer/s.

This list is not exhaustive but only indicative.

BHEL reserve the right to reject one or all offers without assigning any reason. The decision of BHEL will be final in this regard.

- 1. If the offer fails to meet the technical requirements/specifications of the tendered item/s.*
- 2. If the offer does not meet the commercial terms & conditions, such as but not limited to delivery period specified in the tender, Delivery terms, payment terms, Liquidated damages, Risk Purchase, cancellation clause etc., specified in the tender.*
- 3. If the bidder fails to respond to clarification sought, within a reasonable period. In case of doubts / lack of clarity on the technical and commercial offer of the bidder, BHEL will seek clarifications. Bidders are required to respond completely to such BHEL's queries within 3 working days unless otherwise agreed to in writing by BHEL for period beyond 3 days. If supplier fails to respond within 3 working days or maximum 2 working days on a reminder thereon, the offer of such bidders will be automatically dis-qualified in the tender without further recourse to informing the bidder.*

K] Evaluation of Price Bid

i) The rates quoted shall be evaluated RS wise on the basis of "Total cost to BHEL".



ii) If the rates of Two vendors are equal resulting in same ranking, among the equal ranked vendors, the sub-ranking will be done to differentiate (a) to decide the L1-vendor eligible for negotiation and (b) to decide H1-vendor for elimination of higher ranked vendors.

The sub-ranking will be done in-the-order by providing lower ranking for vendors

- (1) Nearer to BHEL by location
- (2) Earlier date of commencement of activity as in MSME certificate
- (3) Having OWN land,
- (4) Become Sole-L1 for more number of Rate Schedules,
- (5) Earlier date of receipt of offer and /or
- (6) Draw of lots as a final measure (in presence of such vendors, who may like to be present).

iii) Tenderer contacted in this tender does not automatically qualify for consideration just because they are found to be the lowest in Tender. BHEL reserves the right to reject any offers without assigning any reasons. BHEL also reserves the right to negotiate or counter offer the rates to any of the parties at their discretion.

iv) If the L1 rate against any rate schedules are found not acceptable to BHEL, then the L1 firms may be called for negotiation before finalizing the rate.

v) BHEL has the right to refloat or short-close the Tender if L1 price is not the lowest acceptable price, or for other reasons.

vi) Elimination of Vendors:

a) H1 vendor will not be considered.

b) Maximum vendors are required for entering in to contract except H1 vendor .

vii) All bidders shall submit their offers by filling-in the format of the BHEL tender documents. Offers received in any other format are liable to be rejected. Offers are asked in BHEL's format for purpose of standardisation - to help in the offer evaluation.

viii) Offer with any pre-conditions (like conditional discounts) for price is liable for rejection.

ix) BHEL reserves the right to reject without assigning any reasons other than already specified for such offers having deviations to BHEL Specifications, Standard Terms & Conditions at its discretion. The decision of BHEL in this regard shall be final.

x) In case of any discrepancy between the description of the Rate Schedule or quantities, specifications, drawings and for other tender documents, the decision of BHEL in writing is final, binding and conclusive for the purpose of this contract.

xi) BHEL reserves the right to reject an offer due to unsatisfactory past performance during tender finalisation / execution of a contract at any of BHEL projects / units.

xii) BHEL reserves the right to conduct negotiations on the "Price" and "Other Commercial Terms and Conditions" with the lowest ranked offeror and

xiii) If so required by BHEL, Supplier may have to share their cost data / costing sheet with BHEL.

xiv) BHEL reserves the right to restrict the number of parties for award of contract for any or all the Rate Schedules and restrict the number of parties to be called for negotiation (if necessary) based on their competitive bidding, past performance etc.



L] Abnormally Low Offers

If the prices offered by L1 Bidders are found to be unrealistic, unworkable with respect to BHEL's estimate or prevailing market rates, BHEL will ask for justification also demand the break up cost element for such rates from the vendors with appropriate documentary evidence and if not submitted it will be construed that the vendor has offered the rates with an intention to sabotage BHEL Tender process/ tamper Tendering procedure, affecting the ordering process. In such cases, BHEL will have the discretion to reject the offer in line with BHEL procedures. Hence the bidders are advised to exercise abundant care in submitting a correct genuine offer.

M] Counter offer

- i) Once the L1 rates for the rate schedule is finalized by BHEL, then the L1 rate shall be counter offered to the other technically qualified vendors for their acceptance.
- ii) Based on the acceptance of vendors for the Rate Schedule, rate contract will be entered with them.
- v) Counter offering will not be extended to top higher ranked (H1.etc.) eliminated vendors as per **clause K (vi)** Counter offering will be made to all participated vendorsexcept H1 ranked vendor .
- vi) If none of the vendors are accepting for the counter offer given by BHEL, then BHEL will place orders on the L1 ranked vendor for the tentative quantity mentioned subject to the capacity availability indicated by the vendor.

N] Placement of Orders and Loading

- a) ARC Contract will be entered only with the **vendors** who respond to this ARC-Enquiry. New vendors who have not responded to this ARC-Tender-but registered/approved later, if any will be permitted in the next year ARC (provided they respond to the next-year ARC).
- b) Annual Rate Contract would be signed by the vendors for the Rate Schedule by way of becoming L1 and accepting counter offer rates for the Rate Schedule with BHEL, Ranipet subject to the availability of requisite acceptable Bank Guarantee.
- c) Tentative quantity likely to be ordered against Rate Schedule is indicated in the Technical Bid. Tender quantity may increase/decrease during the rate contract period. BHEL does not guarantee any minimum load for any vendor.
- d) The contract is to be signed in Rs.100/- stamp paper. Hence after getting a confirmation on signing of contract, vendor shall get a stamp-paper for a value of Rs. 100/- and submit to BHEL for contract preparation.
- e) After finalization of tender, if the Contractor is awarded the Contract, Proprietor, Partners and Directors (as applicable) should physically present themselves and sign the contract in the presence of Head of OS Department with in the dates specified.
- f) Orders would be placed as Addenda's on the Annual Rate Contract signed by the vendors.
- g) *Lowest (L1) vendor will be given TWO(2) splits of load, when all other vendors(other than L1) were given One(1) split , during every bulk loading cycle, subject to meeting all the basic requirements such as Capacity availability, BG, Delivery Performance, Quality Performance, Legal compliances, validity of lease documents, Validity of constitution etc., required as per contract.*
- h) If none of the vendors are accepting for the counter offer given by BHEL, then BHEL will place orders on the L1 ranked vendor for the tentative quantity mentioned against RS subject to the capacity availability indicated by the vendor.



i) The total available load from time to time will be distributed to those Contractors with preference to L1, L2 and L3, with whom Contract is entered into and to that Contract, the addenda shall be placed in a phased manner subject to the availability of potential for BHEL and also depending upon vendor performance such as collection of Raw materials in time, manufacture according to BHEL plans/requirements, meeting quality requirements, prompt returning & account of balance materials and also the minimum required facilities available at the Contractor's works to meet the job requirements and submission of other reports as called for, then and there. BHEL does not guarantee ordering of any minimum quantity on any Contractor.

j) Purchase orders will be issued after entering into Rate contract with the Contractors. Discrepancy in the PO's if any, has to be settled immediately then and there within 10 days from the date of release of PO.

O] Execution of the Order

a) Once the order is released, vendor can view the orders in B2B portal of BHEL, Ranipet. However vendor has to collect hard copies of the Purchase order, IP(issue position), Engineering Drawings and relevant documents from BHEL through their authorised representative.

Based on the Rate contract, to be finalized, the Sub-Contractors shall accept and undertake all jobs awarded to them under various Rate Schedules allotted to them and execute them to the satisfaction of BHEL. Failure to comply with this requirement will be viewed seriously.

b) Vendor has to collect Raw materials / Components from BHEL stores / Shop to their works on clearance.

c) Vendor has to study the Drawings, Welding Procedure Specification (WPS), Standard Quality Plan (SQP), any Customer Hold Points (CHP), any stage inspection requirement etc. carefully before start of manufacture.

d) Vendor has to submit Cutting Plan (CP) for the collected Raw Materials within a week of collection and shall get approval from CP section before proceeding for manufacture.

e) During manufacturing, wherever stage inspection is required, vendor has to offer for inspection to BHEL QC / BHEL approved Inspection Agencies for clearance to proceed further.

f) All measuring Instruments to be calibrated as per standards at BHEL Metrology / any approved Labs on chargeable basis and manufacturing / inspection will be carried out with calibrated instruments only.

g) On completion of Job, final inspection is to be offered to BHEL QC / BHEL approved Inspection Agencies with relevant Dimensional Report (DR). After clearance from the above agencies, Inspection Report (IR) has to be obtained for the same.

h) Painting of one coat Red Oxide / applying of Rust Preventive oil on machined surfaces is to be made on the job.

i) Despatch the items to BHEL, Shipping / Stores along with Delivery Chelan (DC), Inspection Report (IR), and Dimensional Report (DR) each 6 copies and shall get Inward Entry on Delivery Chelan (DC) from the Gate In charge.

j) On delivery, authorised representative of vendor shall follow Shipping / Stores to control the DC's/Stores Receipt Voucher (SRV).

k) Intimation of controlled DC's/SRV will be mailed by Finance to vendors for submitting the Invoices.

l) Vendors have to submit the invoice and relevant documents to finance in stipulated time for the release of payments.

m) In case of new vendors, The Inspection report on **First-of-trial** of First-addendum-PO shall be submitted. Further loading of jobs will only be considered after the successful completion of the First-addendum-PO.



n) The Contractors are responsible till the semi finished components are safely deposited with BHEL / Ranipet. They should carefully pack, Load, and stack as per QWIs, for avoiding damages during transit and lash the consignment properly at the time of dispatch so that the consignment reach the destination safely.

P] Risk Purchase

Alternatively, the BHEL at his option will be entitled the contract and to manufacture elsewhere at the risk and cost of the seller either the whole of the goods or any part which the supplier has failed to deliver or dispatch within the time stipulated as aforesaid or if the same were not available, the best and the nearest available substitute therefor. The supplier shall be liable for any loss which the BHEL may sustain by reason of such risk purchases in addition to penalty at the rate mentioned in LD clause.

In case those vendors do not execute the orders, BHEL may get the job done through other sources at the Risk and cost of those vendors and the extra expenditure involved shall be recovered from these vendors from any amount due to them.

Q] Liquidated Damages:

BHEL will levy penalty as Liquidated Damages (LD), for delay in delivery. The damages shall be at the rate of ½% per week or part thereof subject to a maximum of 10%. Delivery for purpose of L.D, will be reckoned as the date of clearance of the items for dispatch by BHEL. Supplier should quote a definite delivery period and any delay in delivery will attract penalty.

The delivery period includes time involved in material collection, cutting plan approval, collection of further materials if any and handing over of the finished goods to BHEL-Shipping. Finished goods items shall be door delivered at Shipping/Stores inside the factory, BHEL, Ranipet.

R] Termination of Inquiry / Orders:

a) BHEL reserves the right to cancel any inquiry before opening of the tender, without assigning any reason.

b) BHEL reserves the right to cancel any tender and refloat a fresh tender, at any time after opening of the tender, in case it finds the response to its tender as not meeting its requirement. This shall be at the sole discretion of BHEL.

c) In the event of non-performance of the contract by the Supplier, BHEL reserves the right to cancel the order with issue of a written notice. BHEL would provide a curing period of 30 days, for the Supplier to rectify the situation. If the Supplier fails to rectify the reason/s that led to the issue of cancellation notice by BHEL, then the cancellation order would be issued automatically by BHEL, without further recourse to the Vendor. BHEL will not pay any cancellation charges or any other charges / damages to the Supplier, arising out such cancellation.

d) In the event of the non-performance of the contract, by the Supplier, the rights of BHEL include, in addition to cancelling the order, to take alternate action at the cost and risk of the supplier. The additional expenditure to be incurred by BHEL in such alternate action would be to the account of the supplier.

e) BHEL reserves the right to cancel the order for delay in supply beyond penalty period without any monetary or legal obligations and at the risk and cost of the Supplier and

f) BHEL will levy penalty as Liquidated Damages (LD), for delay in delivery. The damages shall be at the rate of ½% per week or part thereof subject to a maximum of 10%. Delivery for purpose of L.D, will be reckoned as the date of clearance of the equipment for dispatch by BHEL.

S) Suspension of Business Dealings with vendors

Before submitting offer, prospective bidders are advised to **visit our web-site www.bhel.com** / supplier registration to familiarize themselves with BHEL's policy and procedures of Suspension of Business Dealings with Suppliers.



Submission of offer shall be deemed to be evidence of the Bidder to have read and understood the above said policy.

T) Reverse auction (RA) / on-line bidding on internet:

1. "BHEL reserves the right to go for Reverse Auction (RA) (Guidelines as available on www.bhel.com) instead of opening the sealed envelope price bid, submitted by the bidder. This will be decided after techno-commercial evaluation. Bidders shall give their acceptance with their offer for participation in RA. Non-acceptance to participate in RA may result in non-consideration of the bids, in case BHEL decides to go for RA."

2. Those bidders who have given their acceptance to participate in Reverse Auction will have to necessarily submit 'Process compliance form' (to the designated service provider) as well as 'Online sealed bid' in the Reverse Auction. Non-submission of 'Process compliance form' or 'Online sealed bid' by the agreed bidder(s) will be considered as tampering of the tender process and will invite action by BHEL as per extant guidelines for "Suspension of Business Dealings with Suppliers/ Contractors (as available on www.bhel.com)."

3. The philosophy followed for reverse auction shall be English Reverse (No ties).

4. For the proposed reverse auction, technically and commercially acceptable bidders only shall be eligible to participate.

5. BHEL will engage the services of a service provider who will provide all necessary training and assistance before commencement of on line bidding on internet.

6. In case of reverse auction, BHEL will inform the bidders the details of Service Provider to enable them to contact & get trained.

7. Business rules like event date, time, bid decrement, extension etc. also will be communicated through service provider for compliance.

8. Bidders have to fax the Compliance form (annexure IV) before start of Reverse auction. Without this, the bidder will not be eligible to participate in the event.

9. Reverse auction will be conducted on scheduled date & time.

Note: Decision to go for RA or not will be on case to case basis.

10. At the end of Reverse Auction event, the lowest bidder value will be known on auction portal.

11. The lowest bidder has to fax/e-mail the duly signed and filled-in prescribed format for price breakup including that of line items, to the Service provider within two working days of Auction without fail.

12. Bidders are be required to read the "Terms and Conditions" section of the auctions site of Service provider, using the Login IDs and passwords given to them by the service provider before reverse auction event. Bidders should acquaint themselves of the „Business Rules of Reverse Auction“, which will be communicated before the Reverse Auction.

13. If the Bidder or any of his representatives are found to be involved in Price manipulation/ cartel formation of any kind, directly or indirectly by communicating with other bidders, action as per extant BHEL guidelines, shall be initiated by BHEL and the results of the RA scrapped/ aborted.

14. The Bidder shall not divulge either his Bids or any other exclusive details of BHEL to any other party.

15. The bidders have to necessarily submit online sealed bid less than or equal to their envelope sealed price bid already submitted to BHEL along with their offer. The envelope sealed price bid of successful L1 bidder in RA, if conducted, would also be opened after the RA and the order will be placed on lower of the two bids (RA closing price & envelope sealed price) thus obtained. It is considered that the bidder having



submitted their offer specifically agrees to this condition and undertakes to execute the contract on thus awarded rate/s.

16. If it is found that L1 bidder has quoted higher in the online sealed bid in comparison to the envelope sealed bid for any item(s), the bidder will be issued a warning letter to this effect. However, if the same bidder again defaults on this count in any subsequent tender, it will be considered as fraud and will invite action by BHEL as per extant guidelines for suspension of business dealings with suppliers/ contractors (as available on www.bhel.com).”

17. The calculation sheet e.g. excel sheet (which will help to arrive at ‘Total Cost to BHEL’) will be communicated to respective bidders of RA by BHEL. In line with the NIT terms, BHEL will provide the calculation sheet (e.g., EXCEL sheet) which will help to arrive at “Total Cost to BHEL” like Packing & forwarding charges, Taxes and Duties, Freight charges, Insurance, Service Tax for Services and loading factors (for non-compliance to BHEL standard Commercial terms & conditions) for each of the bidder to enable them to fill-in the price and keep it ready for keying in during the Auction.]

18. This calculation sheet will be finalized based on the evaluation criteria specified in the NIT.

19. Suppliers are required to submit their best price bid in a separate sealed cover along with techno-commercial bid. After evaluation of Techno-Commercial Bids:

a) In case BHEL decides not to conduct RA, the envelope sealed price bids of all techno-commercially qualified bidders, along with price impact, if any, would be opened and processed as per extant the internal Purchase/ Works Policy as applicable to BHEL.

b) In case BHEL decides to conduct RA, business rules of RA will be sent to service provider.(See Annexure for Model General Business Rules of RA.)

20. Generally the start price for the RA would be the lowest of

a) Lowest online sealed bid and

b) Internal Estimate of BHEL

Note: Wherever more than one lowest online sealed bids are identical and lower than the estimate, the start price, would be that price arrived by reducing the lowest online sealed bid by maximum of one decrement.

21. Reverse auction process would deemed to have started upon receipt of ‘Online Sealed Bids’ from the bidders within the prescribed time frame as per Business Rules.

22. After receipt of ‘online sealed bids’, the start price & bid decrement will be decided by BHEL and the same would be communicated to the service provider, to start the bidding process.

23. Only those bidders who have submitted the ‘online sealed bid’ within the scheduled time would be eligible to participate further in RA process. However, the H1 bidder (whose quote is highest in online sealed bid) will not be allowed to participate in further RA process provided minimum three bidders are left after removal of H1 bidder. In case of tie for H1 bid (identical online sealed bids), 15 minutes additional time would be provided and all the participating bidders would be informed by mail/ message on bidding screen to enable bidders submit revised online sealed bids so as to break the tie.

24. If the lowest online sealed bid is the starting price, then the lowest bidder in online sealed bid shall be shown as current L1 automatically by the system. System would have the provision to indicate this bid as current L1 for further bidding.

25. If the start price is lower than the lowest online sealed bid, on acceptance of such start price by any bidder, this bid would be indicated as current L1 for further bidding.

26. In case of no further bidding, RA will be deemed to have been successful with current L1 bidder.



27. All bidders who had given online sealed bid would be able to see their rank and L1 price and their ranking L1, L2 etc. would be based on their last quoted price irrespective of quote received in RA or online sealed bid.

28. RA shall be treated as failed in the following scenarios:

a) In cases where the start price is (a) estimate or (b) one decrement (maximum) lower than the lowest of the online sealed bids and no bidder accepts the start price.

b) In cases where the number of online sealed bids are less than four before removal of highest bidder.

c) In cases of tie among H1 bidders, even after extension of submission of online sealed bids once by 15 minutes.

d) Wherever, the evaluation is done for individual line items, RA shall be treated as failed only for those line item(s) for which any of the above a), b) or c) satisfies.

29. In cases of failure of RA, sealed envelope price bids (of item(s) for which RA has failed) of all the techno-commercially qualified bidders would be opened and the tender would be processed accordingly. However, the envelope sealed bid(s) of techno-commercially acceptable bidder(s) who had agreed to participate in the RA and had failed to submit the online sealed bid would not be opened.

30. After declaring L1 upon completion of RA, the envelope sealed price bid of L1 bidder would also be opened for placement of order on lower of the two bids (RA closing price & envelope sealed price) and the offers would be processed as per extant their internal Purchase/ Works policy provisions of BHEL. Action as per NIT terms would be taken if online sealed bid is higher than the envelope sealed bid.

31. Relative position of bidders (for usage in cases of predefined splitting the quantities) would also include bidders who have given 'online sealed bids' but have not given further bids in auction. In case of splitting requirement, H1 bidder may be considered for counter offer if the pre-stated (NIT) numbers of suppliers do not accept the counter offer. However, principle of splitting to N-1 bidder would be maintained.

32. In case H1 bidder happen to be MSE and was removed from further bidding but is within L1 + 15% band, then this bid would be considered and to be processed in line with 'Public Procurement Policy for Micro & Small Enterprises (MSEs) order, 2012'.

33. For providing preference to domestically manufactured Electronic Products, in accordance with Department of Electronics and Information Technology (DeitY) Gazette Notification No. 33(3)/2013-IPHW dated 23.12.2013 and its related notifications issued from time to time, H1 bidder removed from further bidding would be considered for counter-offer to meet domestic bidder requirement for the item(s) under procurement.

34. In case BHEL decides not to go for Reverse Auction for the tender enquiry, the Price bids and price impacts, if any, already submitted and available with BHEL would be opened as per BHEL's standard practice.

35. In case of enquiry through e-Procurement, the sealed electronic price bid (e-bid) would be treated as sealed envelope price bid.

Note: In order to bring more transparency and to address any queries of Bidders on Reverse Auction, an abridged version of BHEL's "Common Guidelines for conducting Reverse Auction (RA)" has been hosted in BHEL's web site www.bhel.com under the links "Supplier Registration Page" and "Tender Notification". All Bidders are requested to visit the link and familiarize themselves with BHEL's RA procedures and guidelines before submission of their bid/s. Submission of Bid shall mean that the Bidder has read and understood BHEL's RA procedures and the bid is in agreement with the same.



U] Force Majeure

i) If at any time during the currency of this contract, the performance in whole or in part, by either party of any obligations under this contract shall be prevented or delayed by reason, of any war, hostilities, acts of the public enemy, civil commotion, sabotage, fires, explosions, epidemics, quarantine, restrictions or acts of GOD (hereinafter referred to as events), then provided notice of happening of any such events is given by either party to other within ten days from the date of occurrence thereof, neither party shall reason of such events be entitled to terminate this contract nor shall either party have any such non performance and delay is resumed as soon as practicable after such events has come to an end or ceased to exist. If the performance in whole or part of any obligation under this contract is prevented or delayed by reason or any such event claims for extension of time shall be granted for period considered reasonable by the purchaser subject to prompt notification by the seller to the purchaser of the particulars of the events and supply to the purchaser if required of any supporting evidence. Any waiver of time in respect of partial installment shall not be deemed to be a waiver of time in respect of remaining deliveries.

ii) If as a result of difficulty in procurement of raw materials or due to force majeure reasons or any other reasons what-so-ever the contractor is unable to keep the delivery schedule of the contractee, extension of time may be granted by the contractee at their discretion as may be necessary to the extent considered necessary should there be delay in supply beyond the extended date of delivery, it shall be open to the contractee to terminate the contract in part or full and make other arrangements for executing fabrication elsewhere at the cost and risk of the contractor.

V] Applicability of Integrity Pact

IP is a tool to ensure that activities and transactions between the company and its Bidders/ Contractors are handled in a fair, transparent and corruption free manner. A panel of Independent External monitor (IEMs) have been appointed to oversee implementation of IP in BHEL.

The IP as enclosed with the tender is to be submitted (duly signed by authorized signatory who signs in the offer) along with techno-commercial bid. Only those bidders who have entered into such an IP with BHEL would be competed to participate in the bidding. In other words, entering into pact would be a preliminary qualification.

A detail of IEM for this tender is furnished along with Integrity Pact format **Annexure-H**

Please refer section-8 of the IP for Role and Responsibilities of IEMs. In case of any complaint arising out of the tendering process, the matter may be referred to the IEM mentioned in the tender.

No routine correspondence shall be addressed to the IEM (phone / post/ email) regarding the clarifications, time extensions or any other administrative queries, etc. on the tender issued. All such clarification/issues shall be addressed directly to the tender issuing (procurement) department”.

Integrity Pact are applicable for all the BHEL enquiries whose estimated value is equal to or more than Rupees 5 Crores.

Copy of Integrity Pact with applicable nominated IEM is attached along with the tender documents for ready reference of Suppliers.

If any Supplier attempts to bribe, or pay commission, gift or any advantage or bring in undue influence either by himself or on his behalf any one including a stranger to the tender, in addition to instituting legal proceedings as per the extant laws prevailing, will disqualify the supplier from this tender and all future tenders of BHEL. Decision of the Purchaser would be final in this matter.

f) The laws governing this transaction shall be the laws in India.



g) Wherever not specified, Inco terms 2010 shall be used to interpret the Commercial terms and conditions and

h) In the event of an order, Supplier shall agree to settlement of disputes or differences, if any, by way of arbitration, in accordance with the "Rule of Arbitration" of the Indian Council of Arbitration.

The language in the tender documents downloaded by the Bidders shall at no point of time be changed, altered or modified in any manner by the Tenderer. If such changes are made by any tenderer, it shall be considered as tampering with BHEL's terms and the offer shall be summarily rejected, whenever it is noticed by BHEL. Such Bidders would be disqualified from the Bidding Process and their offers would be forfeited / Bank Guarantees invoked. They would also not be allowed to participate in future tenders of BHEL.

W] Fraud Prevention Policy:

The Bidder along with its associate/ collaborators/ sub-contractors/ sub-vendors/ consultants/ service providers shall strictly adhere to BHEL Fraud Prevention Policy displayed on **BHEL website <http://www.bhel.com>** and shall immediately bring to the notice of BHEL Management about any fraud or suspected fraud as soon as it comes to their notice.

As per BHEL's Fraud prevention Policy, Nodal officers were nominated by BHEL Management. The details of such Nodal officers are furnished below:

Name	Designation	E-mail	Phone (Office)
C.P.Chengappa	GM - NP, Services & PC	chengappa@bhe.in	04172-284587
P.Raguraman	GM - Operations	pr@bhel.in	04172-284574
P.Ravikumar	GM - MM	pravi@bhel.in	04172-284450
S. Anilkumar	GM - BE & Civil	sanil@bhel.in	04172-284681
P.Jayakanth	GM - Engineering	pjayakanth@bhel.in	04172-284167
S.Kannan	GM - Finance & Receivable Management	skannan@bhel.in	04172-284518
B. Srinivasa Rao	GM - Outsourcing	bsrao0104@bhel.in	04172-284945
Rupesh Telang	GM - WCM & Shipping	rt1@bhel.in	04172-284300
G A Saravanan	GM - Marketing & New growth areas	saravananga@bhel.in	04172-284446

Any bidder / contractor who come across any fraudulent behaviour of BHEL's employees may communicate the same to any / all of these Nodal officers.

X] Others

a) The Firms are advised to study and understand the scope of work and the entire process of Contract execution involved before quoting. Any technical clarifications required can be sought in person or by e-mail one week before the due date of Tender opening.

b) In case of any contradiction in the terms and conditions given here and elsewhere in the other documents of the tender or any omissions in the Tender documents or for any clarifications in the tender conditions, it shall be the responsibility of the tenderer to get it clarified from BHEL. The officer authorized to provide such clarifications is the Manager / Contracts, Outsourcing Department, Phone: 04172 – 284030, e-mail bsmanian@bhel.in, ssvasan@bhel.in

c) Alterations to the conditions of the Tender can be done only by the authorized officer, at any time before the date and time of tender opening. Such changes, if any, would be communicated in writing and / or hosted in the web-page.



- d) BHEL will conclude that the offer has been submitted by the firm fully understanding all the requirements both explicit and implied and other conditions and accepting the same. After tender opening, the bidders are not allowed to change / alter any of the conditions either partly or fully. Offers of any such firms doing so, will be rejected.
- e) Conditional and late Tenders, Tenders which are incomplete or otherwise considered defective with respect to Tender conditions and Tenders not in accordance with the Tender conditions herein contained and the Tenders not in original shall be rejected out rightly, at any point of time during the Tender processing.
- f) Should the tenderer or the contractor have a relation or relations in the case of a firm or company of contractors, one or more of its shareholders or relations or relations of the share holders employed in BHEL or any ex-employee who has retired / resigned within a period of two years as on date of quotations or at any subsequent date after the award of the contract, the authority inviting the Tender shall be informed of the fact at the time of submission of the tender and there after as applicable and obtain the clearance of BHEL for such engagement failing which, BHEL may in its own discretion reject the tender or rescind the contract.
- g) If a Bidder is found to have given false information / documents as a part of their offer, such offers shall be rejected / the contract shall be terminated and the firm shall be banned from getting business from all BHEL units.
- h) If any Supplier attempts to bribe, or pay commission, gift or any advantage or bring in undue influence either by himself or on his behalf any one including a stranger to the tender, in addition to instituting legal proceedings as per the extant laws prevailing, will disqualify the supplier from this tender and all future tenders of BHEL. Decision of the Purchaser would be final in this matter.
- i) The laws governing this transaction shall be the laws in India.
- j) The tenderer shall acquaint himself with the conditions/limitations and official regulations under which or conforming to which the jobs are to be performed and shall examine carefully at the information as may be furnished to them in writing from time to time.
- k) The tenderer shall acquaint himself with applicable Acts.
- l) As a policy BHEL is not registering any power of attorney issued by Contractors/Contractors in favour of their bank for the collection of Invoice amounts on behalf of Contractors/Contractors and merely because BHEL had acted upon any such request by the party or their bankers does not constitute any legal right or binding on BHEL for any acts of omissions and commissions or failure to act upon it or for any payment made directly to the party. If any banker includes BHEL also as a party to any such dispute between the banker and the party, All legal and incidental expenses thereof will be recovered from the concerned parties only.
- m) In the event of an order, Supplier shall agree to settlement of disputes or differences, if any, by way of arbitration, in accordance with the "Rule of Arbitration" of the Indian Council of Arbitration.
- n) The offer/s of such of those bidders who do not accept for levy of liquidated damages (LD) for delay in delivery and who do not accept for submission of the BG for the value and period specified herein above is likely to be summarily rejected. No correspondence would be entertained by BHEL in this regard, on this subject. BHEL specifically draws the need of this mandatory requirement to the notice of all Bidders. The Price Bid of such of those offerers failing to meet this requirement, would not be considered for the Price-Bid Opening.*
- o) The language in the tender downloaded by the Bidders shall at no point of time be changed, altered or modified in any manner by the Tenderer. If such changes are made by any tenderer, it shall be considered as tampering with BHEL's specifications and the offer shall be summarily rejected, whenever it is noticed by BHEL. Such Bidders would be disqualified from the Bidding Process and their offers would be forfeited / Bank Guarantees invoked. They would not be allowed to participate in future tenders of BHEL.*



Y] General :

1.0 Definitions : Throughout these conditions and in the specifications the terms :

(a) **"The Contractee"** means the Bharat Heavy Electricals Limited, acting through the Additional General Manager, Outsourcing Department, Boiler Auxiliaries Plant, Ranipet – 632 406 unless the context otherwise provides.

(b) **"The Contractor"** means the person, firm or company with whom the order for machining / fabrication is placed and shall be deemed to include the Contractor's successor (approved by the Contractee), representatives, heirs, executors and administrators, as the case may be, unless excluded by the terms of the Contract.

(c) **"The Drawings"** means the drawings exhibited or provided for the guidance of the Contractor.

1.0 Execution :

The whole contract is to be executed in the most approved substantial and workman like manner to the entire satisfaction of the contractee, or the inspecting officer, who shall have power to reject any of the fabrication of which he may disapprove; and his decision thereon and on any question as to the true intent and meaning of the specifications of drawings or of the work necessary for the proper completion of the contract, shall be final and conclusive. The contractee may require alterations if any to be made during the progress of machining /fabrication, and should these alterations be such that either partly to the contract considers an alteration in the changes justified such alteration shall not be carried out until amended cost of machining /fabrication charges have been submitted by contractor and accepted to fabricate without obtaining the consent of the contractee in writing to an amended cost of machining /fabrication charges, the contractor shall be deemed to have agreed to execute fabrication at such charges as may be considered reasonable by the contractee.

2.0 Interpretation :

Any dispute or difference of opinion in respect of the interpretation, effect or application of this particular condition of the contract or of the amount recoverable here under from the contractor shall be decided by the contractee and the decision shall be final and conclusive.

3.0 Book Examination Clause :

(a) The contractor shall, whenever required, produce or cause to be produced for examination by any officer of the contractee authorized in that behalf any cost or other account book or account voucher, receipt letter, memorandum, paper or writing or any copy of extract from any such document and also furnish information and returns verified in such a manner as may be required in any way relating to the execution of this contract or relevant for verifying, ascertaining, the cost of execution of this contract (the decision of such officer of the contractee on this question or relevancy of any document, information or return being final and binding on the parties). The obligation imposed by this clause is without prejudice to the obligation of the contract/Job-Work-Order or under any statutory rules or orders binding the contractor.

(b) The contractor shall, if the authorized officer of the contractee so requires (whether before or after the prices have been finally fixed), afford facilities to the officer of the contractee concerned to visit the contractor's works for the purpose of examining the process of manufacture and estimate of ascertaining the cost of production of the articles. If any portion of the work be carried out by a Contractor or any subsidiary or an allied firm or company, the authorized officer of the contractee shall have power to secure the books of such Contractor or any subsidiary or an allied firm or company shall be open to this inspection.

4.0 Set – Off Clauses :

BHEL shall have the right to recover any money which in the sole opinion of BHEL is due from the Contractor from any money due to the Contractor under this Contract or any other contract or from the Security Deposit furnished by the Contractor under this Contract or any other contract.



"For the sake of clarity, the phrases "from any money due to the contractor" and "from the Security Deposit furnished by the Contractor" shall include money due from and Security Deposit furnished to any other Unit/ Office of BHEL as the case may be".

5.0 Laws Governing the Contract :

- (a) The contract shall be governed by the laws of Government of India in force.
- (b) Irrespective of the place of execution of the contract, place of delivery, place of payment under the contract, the contract shall be deemed to have been made at Ranipet.

6.0 The Global Compact :

Global compact is a signature initiative of United Nations Security General and four United Nation Agencies

- Office of the High Commissioner for Human rights
- International Labour Organization
- United Nations Environment Programme
- United Nations Development programme

This is a board based initiative and engages:

- Individual Companies
- Business Associations
- International Labour
- Human Rights, Environment and development Organisations
- Academic & Public Policy Instructions and United Nations

The Contractee (BHEL) is a member of this Global Compact. As a participating Company, We have the obligation to

- ** Support and respect Human rights with in our spheres of influence.
- ** Make sure we are not complicit in Human right abuses.
- ** Make sure we are not employing forced or compulsory labour.
- ** Refrain from employing child labour
- ** Eliminate discrimination in our hiring and firing policies
- ** Support a precautionary approach to Health, Safety of employees and society and environmental challenges.
- ** Undertake initiatives to promote greater environmental responsibility
- ** Encourage development and diffusion of environmentally friendly technologies.

Contractor shall also ensure to fall in line with the above principles.

8.0 Occupational Health and Safety Management System (OHSAS 18001) and Environmental Management System (EMS 14001)

BHEL/BAP/RANIPET got accreditation Occupational Health and Safety Management System (OHSAS 18001) and Environmental Management System (EMS 14001). As per this, OS Contractors are requested to meet the requirements of EHS (Environmental Health & Safety) guidelines (mentioned below), while engaging and using Vehicles for incoming/outgoing transportation.

- To have valid Driving licence and RC book for the Transports
- To load the vehicle/bullock cart within the Safe Working Load (S.W.L.) The S.W.L. is to be displayed/painted on the vehicle/bullock cart.



- To load the material in such a way that it should not project outside the dimensions of the Vehicle/bullock cart.
- To stack the material in a manner that the material should not slide/fall during transportation.
- During manual lifting with an Adult, the weight should not exceed 50 kg.
- To attempt to adopt OHSAS 18001 / ISO 14001 requirements in their manufacturing process at Contractor's work place.
- To comply with applicable provisions of the Central Motor Vehicles Rules 1989 (Rule:136 and if any). List of important Phone Nos: (given by OS) should be available with the driver while transporting BHEL materials.
- To train drivers to handle emergency situation during transportation.
- To follow the Various Acts/Rules and Regulations (particularity Factories Act 1948 and Tamil Nadu Factory Rules 1950) applicable to them.
- To maintain valid PUC (Pollution Under Control) certificates and produce while vehicle is in this company premises.

Contractors are requested to meet the requirements of OHSAS 18001 / ISO 14001 as given below:

- ** To adopt OHSAS 18001 / ISO 14001 requirements in their manufacturing process at Contractor's work place.
- ** To comply with applicable provisions of the Central Motor Vehicles Rules 1989 (Rule: 136 and if any).
- ** To follow the applicable Acts/Rules and Regulations (like Factories Act 1948 and Tamil Nadu Factory Rules – 1950) applicable to them.
- ** In addition to this, they should follow the day to day communication of OS on this regard.

Special Note:

BHEL is a Government of India Undertaking. Its procurement practices are governed by the (Internal) Purchase Policy issued by the management of the company and as per the tender conditions applicable at the time of finalising the order against this tender.



ANNEXURE FOR REVERSE AUCTION

Model General Business Rules for Reverse Auction

This has reference to tender no {tender number....date...}. BHEL shall finalise the Rates for the supply of {item name} through Reverse Auction mode. BHEL has made arrangement with M/s. {Service provider}, who shall be BHEL's authorized service provider for the same. Bidders should go through the instructions given below and submit acceptance of the same.

The technical & commercial terms are as per (a) BHEL Tender Enq. No. {...} dated {...}, (b) Bidders' technical & commercial bid (in case of two part bid) and (c) subsequent correspondences between BHEL and the bidders, if any.

1. Procedure of Reverse Auctioning

- i. Online Sealed Bid: This duration of online sealed bid will be {...} minutes. All bidders to submit their online sealed bids during this period.
- ii. Online Reverse Auction: The 'opening price' i.e. start price for RA and 'bid decrement' will be decided by BHEL.
- iii. If BHEL decides the lowest online sealed bid as the starting price, then the lowest bidder in online sealed bid shall be shown as current L1 automatically by the system and no acceptance of that price is required. System shall have the provision to indicate this bid as current L1.
- iv. Bidders by offering a minimum bid decrement or the multiples thereof can displace a standing lowest bid and become "L1" and this continues as an iterative process.
- v. After the completion of the online reverse auction, the Closing Price (CP) shall be available for further processing.

2. Schedule for Reverse Auction: The Reverse Auction is tentatively scheduled on {date}: and the duration of online sealed bid will be {...} minutes. All bidders to submit their online sealed bids during this period.

- Online Sealed Bid:-

- {Start Time:
- Close Time: }

- Online Reverse Auction:-

- {Start Time:
- Close Time: }

3. Auction extension time:

If a bidder places a bid in the last {...} minutes of closing of the Reverse Auction and if that bid gets accepted, then the auction's duration shall get extended automatically for another {...} minutes, for the entire auction (i.e. for all the items in the auction), from the time that bid comes in. Please note that the auto-



extension will take place only if a bid comes in those last {...} minutes and if that bid gets accepted as the lowest bid. If the bid does not get accepted as the lowest bid, the auto-extension will not take place even if that bid might have come in the last {...} minutes. In case, there is no bid in the last {...} minutes of closing of Reverse Auction, the auction shall get closed automatically without any extension. However, bidders are advised not to wait till the last

minute or last few seconds to enter their bid during the auto-extension period to avoid complications related with internet connectivity, network problems, system crash down, power failure, etc.

The above process will continue till completion of Reverse Auction.

Complaints/ Grievances, if any, regarding denial of service or any related issue should be given in writing thru e-mail/ fax to M/s. {Service provider} with a copy to BHEL within 15 minutes prior to initial closing time of Online Reverse Auction.

4. Bid price: The Bidder has to quote the {...} Price inclusive of Packing & Forwarding charges, all the routine & type tests as per tender scope, ED + cess, CST against C-form, Freight (bidder to provide original Freight paid receipt), insurance charges, etc. including loading (if indicated by BHEL due to deviations in technical/ commercial terms) for the Items specified. Details are as shown in Excel Sheet for calculation of total cost to BHEL (To be specified by Unit as per NIT conditions).

5. Bidding currency and unit of measurement:

Bidding will be conducted in *Indian Rupees per Unit* of the material as per the specifications {...}

In case of foreign currency bids, exchange rate (TT selling rate of State Bank of India) as on scheduled date of tender opening (Part-I bid) shall be considered for conversion in Indian Rupees. If the relevant day happens to be a Bank holiday, then the forex rate as on the previous bank (SBI) working day shall be taken.

6. Validity of bids: Price shall be valid for {... days} from the date of reverse auction. These shall not be subjected to any change whatsoever.

7. Lowest bid of a bidder: In case the bidder submits more than one bid, the lowest bid at the end of Online Reverse Auction will be considered as the bidder's final offer to execute the work.

8. Bidders shall be assigned a **Unique User Name & Password** by M/s. {Service provider}. Bidders are advised to change the Password and edit the information in the Registration Page after the receipt of initial Password from M/s. {Service provider} to ensure confidentiality. All bids made from the Login ID given to the bidders will be deemed to have been made by the bidders/ bidders' company.

9. Post auction procedure: BHEL will proceed with the Lowest Bid in the Reverse Auction for further processing.

10. Any commercial/ technical loading shall be intimated to bidders prior to RA. The excel sheet provided in this regard shall cover all these aspects. Commercial/ technical loading if any, shall be added by the respective bidder in its price during online sealed bid & Online Reverse Auction. Modalities of loading & de-loading shall be separately intimated to the bidders. The responsibility for correctness of total cost to BHEL shall lie with the bidders.

11. Computerized reverse auction shall be conducted by BHEL (through M/s. {Service Provider}), on pre-specified date, while the bidders shall be quoting from their own offices/ place of their choice. Internet connectivity shall have to be ensured by bidders themselves.

During the RA process if a bidder is not able to bid and requests for extension of time by FAX/ email/ phone then time extension of additional 15 minutes will be given by the service provider provided such requests come before 5 minutes of auction closing time. However, only one such request per bidder can be entertained. Despite this extension if bidder fails to upload his prices due to extreme case of failure of Internet connectivity, (due to any reason whatsoever may be) it is the bidders'

responsibility/ decision to send fax communication immediately to M/s. {Service provider}, furnishing the price the bidder wants to bid online with a request to the service provider to upload the faxed price online so that the service provider will upload that price online on behalf of the Bidder. It shall be noted clearly that the concerned bidder communicating this price to service provider has to solely ensure that the fax message is received by the service provider in a readable/ legible form and also the Bidder should simultaneously



check up with service provider about the clear receipt of the price faxed. It shall also be clearly understood that the bidder shall be at liberty to send such fax communications of prices to be uploaded by the service provider only within the closure of Bid time and under no circumstance it shall be allowed beyond the closure of Bid time /reverse auction. It shall also be noted that the service provider should be given a reasonable required time by the bidders, to upload such prices online and if such required time is not available at the disposal of the Service provider at the time of receipt of the fax message from the bidders, the service provider will not be uploading the prices and either BHEL or the service provider are not responsible for this unforeseen circumstances. In order to ward-off such contingent situation bidders are requested to make all the necessary arrangements/ alternatives whatever required so that they are able to circumvent such situation and still be able to participate in the reverse auction successfully. Failure of power or loss of connectivity at the premises of bidders during the Reverse auction cannot be the cause for not participating in the reverse auction. On account of this, the time for the auction cannot be extended and neither BHEL nor M/s. {Service provider} is responsible for such eventualities.

12. Proxy bids: Proxy bidding feature is a pro-bidder feature to safeguard the bidder's interest of any internet failure or to avoid last minute rush. The proxy feature allows bidders to place an automated bid in the system directly in an auction and bid without having to enter a new amount each time a competing bidder submits a new offer. The bid amount that a bidder enters is the minimum that the bidder is willing to offer. Here the software bids on behalf of the bidder. This obviates the need for the bidder participating in the bidding process until the proxy bid amount is decrementally reached by other bidders. When proxy bid amount is reached, the bidder (who has submitted the proxy bid) has an option to start participating in the bidding process.

The proxy amount is the minimum amount that the bidder is willing to offer. During the course of bidding, the bidder cannot delete or change the amount of a proxy bid. Bids are submitted in decrements (decreasing bid amounts). The application automates proxy bidding by processing proxy bids automatically, according to the decrement that the auction originator originally established when creating the auction, submitting offers to the next bid decrement each time a competing bidder bids, regardless of the fact whether the competing bids are submitted as proxy or standard bids. However, it may please be noted that if a manual bid and proxy bid are submitted at the same instant manual bid will be recognized as the L1 at that instant. In case of more than one proxy bid, the system shall bid till it crosses the threshold value of 'each lowest proxy bid' and thereafter allow the competition to decide the final L1 price. Proxy bids are fed into the system directly by the respective bidders. As such this information is privy only to the respective bidder(s).

13. Bidders are advised to get fully trained and clear all their doubts such as refreshing of screen, quantity being auctioned, tender value being auctioned etc. from M/s. {Service provider}.

14. M/s. {Service provider}, shall arrange to demonstrate/ train the bidder or bidder's nominated person(s), without any cost to bidders. M/s. {Service provider}, shall also explain the bidders, all the business rules related to the Reverse Auction. Bidders are required to submit their acceptance to the terms/ conditions/modalities before participating in the Reverse Auction in the process compliance form as enclosed. Without this, the bidder will not be eligible to participate in the event.

15. Successful bidder shall be required to submit the final prices (L1) in prescribed format (Annexure-VI) for price breakup including that of line items, if required, quoted during the Online Reverse Auction, duly signed and stamped as token of acceptance without any new condition (other than those already agreed to before start of auction), after the completion of auction to M/s. {Service provider} besides BHEL within two working days of Auction without fail.

16. Any variation between the final bid value and that in the confirmatory signed price breakup Document will be considered as tampering the tender process and will invite action by BHEL as per extant guidelines for suspension of business dealings (as available on www.bhel.com).

17. Bidders' bid will be taken as an offer to execute the work/ supplies of the item as per enquiry No. {...} dt. {...}. Bids once made by the bidder, cannot be cancelled/ withdrawn and bidder shall be bound to execute the work as mentioned above at bidder's final bid price. Should bidder back out and not execute the contract as per the rates quoted, BHEL shall take action as per extant guidelines for suspension of business dealings (as available on www.bhel.com).



- 18.** Bidders shall be able to view the following on their screen along with the necessary fields during Online Reverse Auction:
- Leading (Running Lowest) Bid in the Auction (only total price of package).
 - Bid Placed by the bidder.
 - Start Price.
 - Decrement value.
 - Rank of their own bid during bidding as well as at the close of auction
- 19.** BHEL's decision on award of contract shall be final and binding on all the Bidders.
- 20.** BHEL reserves the right to extend, reschedule or cancel the Reverse Auction process at any time, before ordering, without assigning any reason, with intimation to bidders.
- 21.** BHEL shall not have any liability to bidders for any interruption or delay in access to the site irrespective of the cause. In such cases, the decision of BHEL shall be binding on the bidders.
- 22.** Other terms and conditions shall be as per bidder's techno-commercial offers and other correspondences, if any, till date.
- 23.** If there is any clash between this business document and the FAQ available, if any, in the website of M/s. *{Service provider}*, the terms & conditions given in this business document will supersede the information contained in the FAQs. Any changes made by BHEL/ service provider (due to unforeseen contingencies) after the first posting shall be deemed to have been accepted if the bidder continues to access the portal after that time..
- 24.** Bidder shall not divulge either his Bids or any other exclusive details of BHEL to any other party. If the Bidder or any of his representatives are found to be involved in Price manipulation/ cartel formation of any kind, directly or indirectly by communicating with other bidders, action as per extant BHEL guidelines for suspension of business dealings (as available on www.bhel.com), shall be initiated by BHEL.



RA price confirmation and breakup
(To be submitted by L1 bidder after completion of RA)

To
- M/s. Service provider
- Postal address

CC: M/s BHEL

BOILER AUXILIARIES PLANT
INDIRA GANDHI INDUSTRIAL COMPLEX
RANIPET – 632406
TAMILNADU
INDIA.

Sub: Final price quoted during Reverse Auction and price breakup

Dear Sir,

We confirm that we have quoted.

Rs. { _____ in value & in words _____ } for item(s) covered under tender enquiry
No. {...} dt. {...}

Total price of the items covered under above cited enquiries is inclusive of {Packing & forwarding, E.D. , C.S.T. , freight and insurance charges up to {.....} District, {.....} State and Type Test Charges etc., (exclusive of service tax), other as per NIT }

as our final landed prices as quoted during the Reverse Auction conducted today {date} which will be valid for a period of { ___ in nos. & in words ___ } days.

The price break-up including that of line items is as given below.

Total =====
- Rs.in value & in words
=====

Thanking you and looking forward to the valuable order from BHEL.

Yours sincerely,
For _____
Name:
Company:
Date:
Seal:

Product : ESP middle/top/roof/insu supp panels



INSULATOR SUPP. PANEL

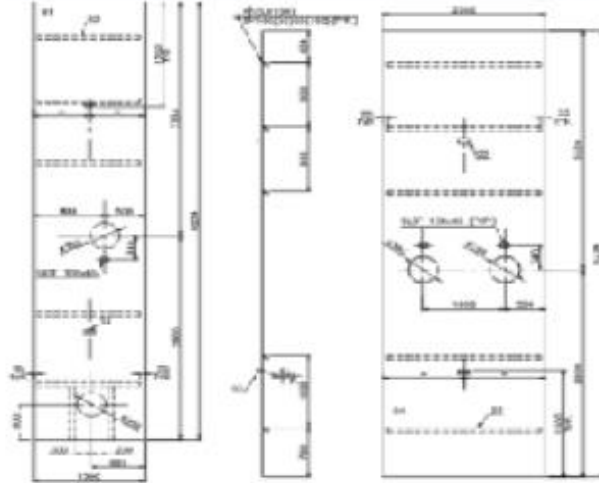

Process involved:

- 1) Plate Cut to size
- 2) Stiffeners welding
- 3) Holes drilling

MIDDLE PANEL

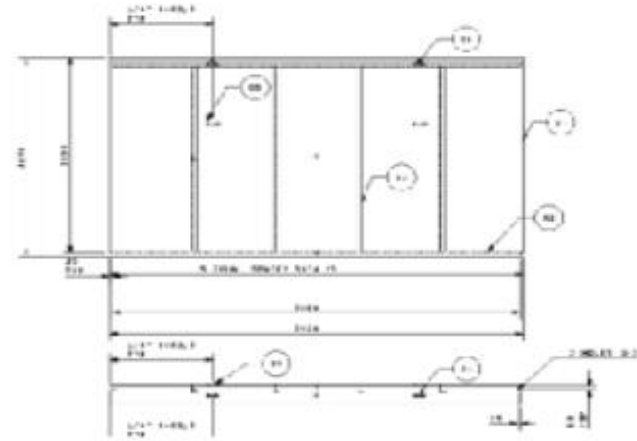

ROOF PANEL

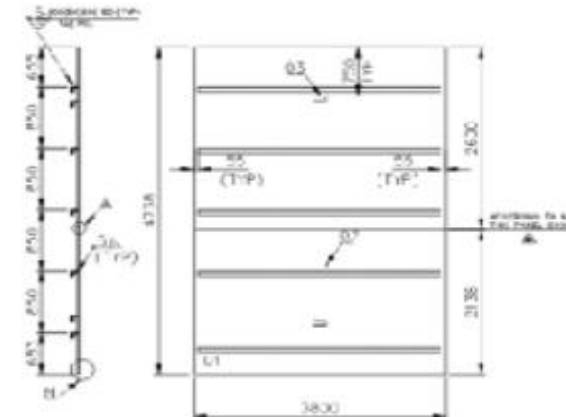

GABLE TOP

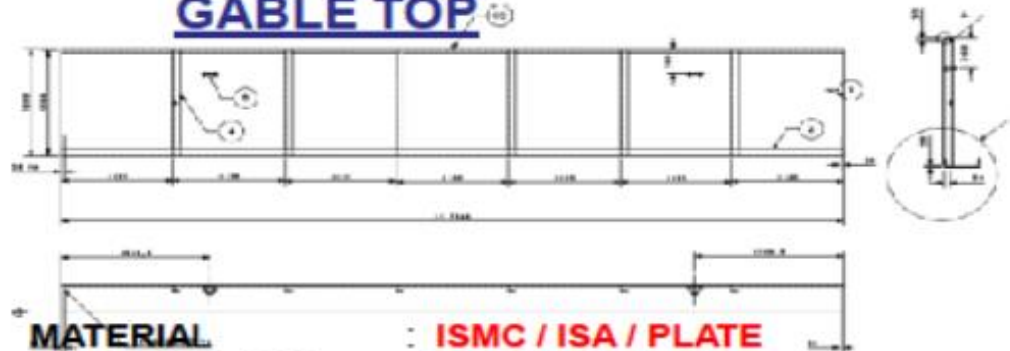

MATERIAL : ISMC / ISA / PLATE
SPECIFICATION : IS 2062 GR A
WELDING CONSUMABLE : E 6013

Product : ESP Hoppers

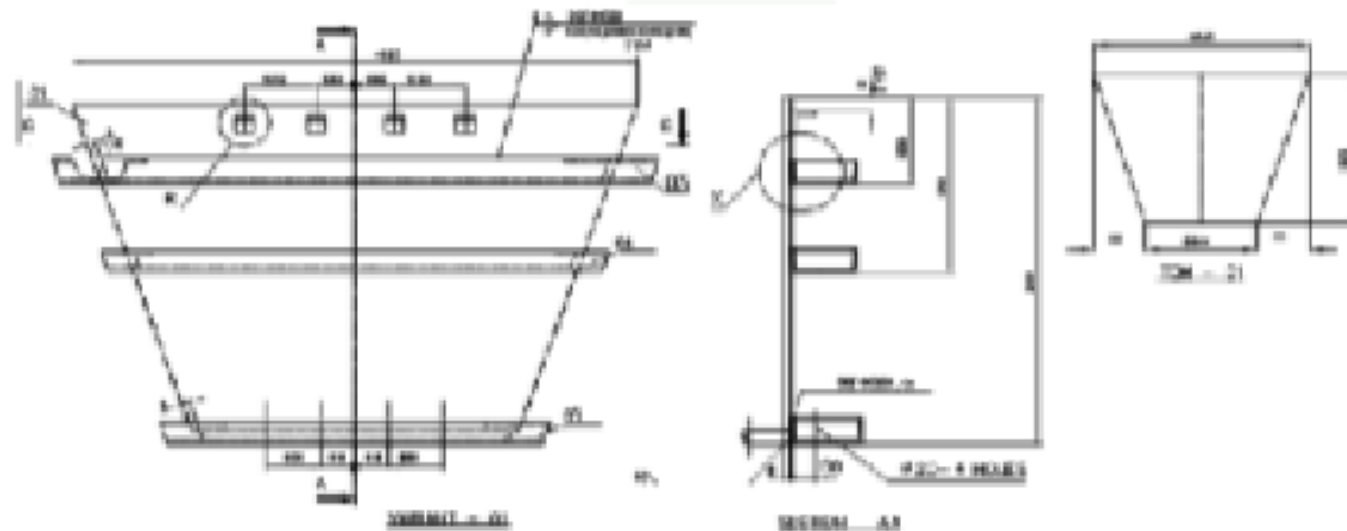

MATERIAL : ISMC / ISA / PLATE
SPECIFICATION : IS 2062 GR A
WELDING CONSUMABLE : E 6013

Process involved:

- 1) Plate Cut to size
- 2) Stiffeners welding
- 3) Holes drilling

Section-VI

Enquiry No.658014E

Dt.16.09.2019

Flow chart for processing of Material Account Statement (MAS)

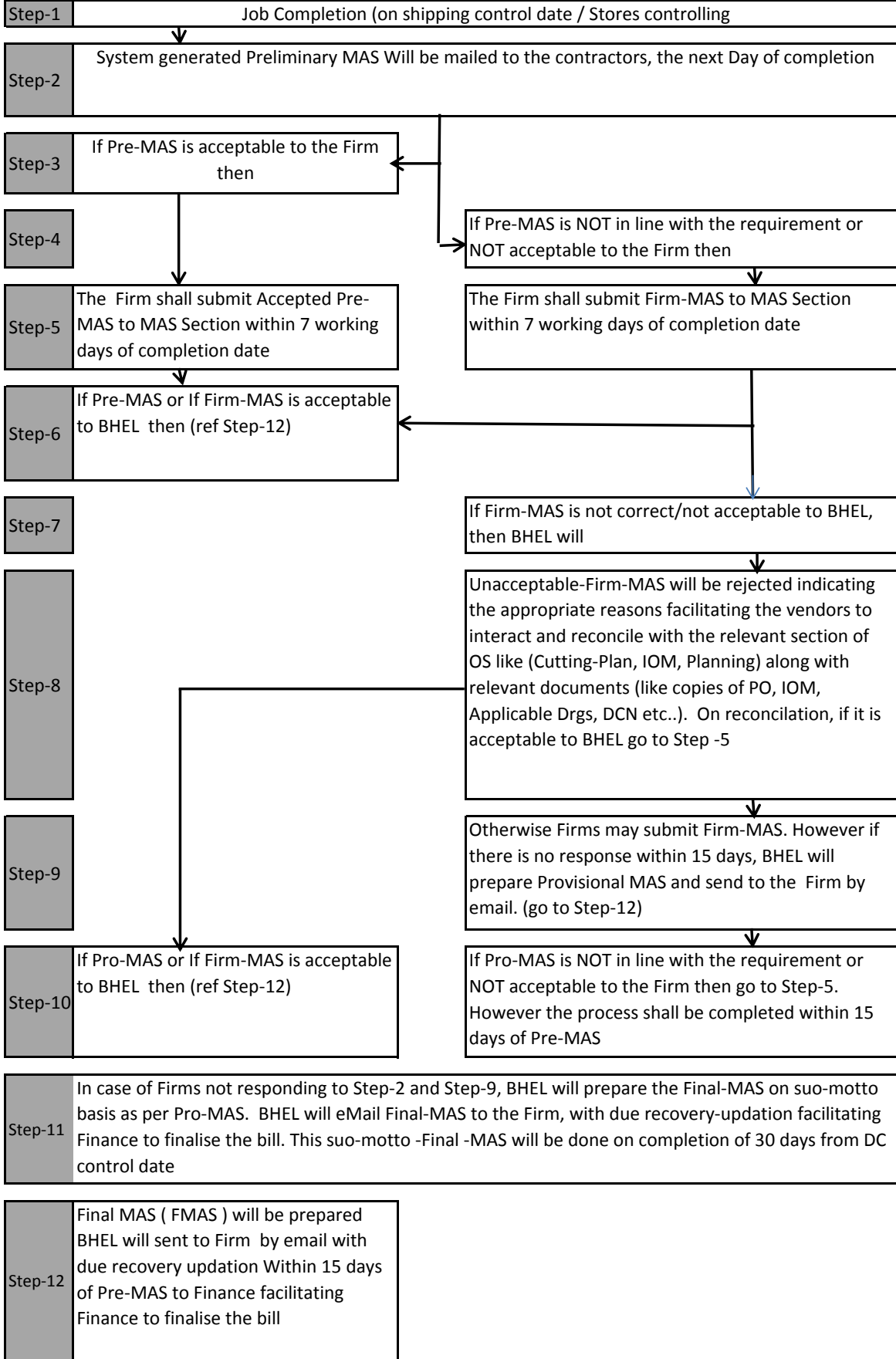

NOTE: Even in the case of activities not covering in the above process, the overall process lead time to book FMAS is 30 days from date of completion of the job.

SECTION-VIII

 An ISO Company	BHARAT HEAVY ELECTRICALS LIMITED (A Government of India Undertaking) பாரதமீக்ரமின் நிறுவனம்	Ph: 04172-284030, 284323, 241120 Email: bsmanian@bhel.in ssvasan@bhel.in
	BOILER AUXILIARIES PLANT, Indira Gandhi Industrial Complex,	
	RANIPET- 632 406 (Tamil Nadu)	

BHEL-BAP-OS-54AA-ARC-2019-20

SECTION – VIII - List of Approved vendors for (A) Welding Consumable ,Paints, Penetrant Chemicals and (B) Conducting NDT, Galvanising and Heat Treatment

Ref	Description	Page No
1	List of approved welding Consumables Suppliers	01 to 27
2	List of approved Paint Suppliers	01 to 03
3	List of approved Suppliers for Penetrant Chemicals	01 to 05
4	List of approved NDT vendors	01 to 05
5	List of approved Galvanising Vendor	01 to 01
6	List of approved Heat Treatment Vendor	01 to 04

**SECTION - VIII
LIST OF APPROVED VENDORS**

1) WELDING CONSUMABLES SUPPLIERS LIST

Mat Group	Material Group Description	Vendor No	Vendor Name	Vendor Address	EMAIL	PHONE1
DRMFL	WELDING FLUX-DRUM	20047	KANEMATSU TRADING CORPORATION	6th FLOOR,AKEBONO NIHONBASHI BLDG,19 - 5,NIHONBASHIKOAMI-CHO,CHUO - KU, TOKYO, 103 - 0016.	nikko-bocki@kgt.kanematsu.co.jp	81 3 5283 3680
		10081	ESAB INDIA LTD	KARUMUTTU CENTRE, 6TH FLOORNEW NO.634(OLD NO.498)ANNA SALAI, NANDANAM,CHENNAI-35CHENNAI	jagdeesh.ds@esab.co.in	044-826 9343
		11712	TAPADIA ENGINEERS & TRADERS P.LTD.	2, INDUSTRIAL ESTATE,BHANPURI, CHATTISGARH.RAIPUR	tet_tgirpr@rediffmail.com	0770 - 4090636
FINFL	WELDING FLUX-FIN	11712	TAPADIA ENGINEERS & TRADERS P.LTD.	2, INDUSTRIAL ESTATE,BHANPURI, CHATTISGARH.RAIPUR	tet_tgirpr@rediffmail.com	0770 - 4090636
		19371	NDT FLUXES.	SURAJ,35,VIVEKANANDA NAGAR,RAIPUR		
GVW01	WELDING ELECTRODES	11378	MAILAM INDIA LIMITED	MAILAM MAIN ROAD,SEDARAPET,PONDICHERRY	mailam@mailanindia.com	0413-2677311
		80019	ESAB INDIA LTD.	KIRTI NAGAR		
		80018	D & H INDIA LIMITED	182/75, INDUSTRIAL AREA PH- 1CHANDIGARH	dnhindiachd@yao.co.in	0172- 2653063
		80020	HONAVAR ELECTRODES PVT LTD	Industrial Complex, 9, LBS Marg, Kurla (West)Mumbai	honavarelectrodes@gmail.com	9820249301
		10774	D&H SECHERON ELECTRODES PVT LTD.	P.B.NO.344-46,INDL.ESTATE,KILAMAIDANINDORE	sales@dnhsecheron.net	0731-4229222
		80291	Bharat Heavy Electricals Limited ,T	TiruvaramburTrichy		
		80218	M/s Modi Arc Electrodes Co.	G.T. Road, Oil Mill Gate, Modinagar		
		80126	Ador Welding Limited	C-116, Naraina Industrial Area, Phase-1New Delhi	delhi@adorwelding.com	1141411049
10936	AHURA WELDING ELECTRODE MANUFACTURE	SF 139 & 144/3 THIRUMALAYAMPALAYAMPALGHAT ROADPALGHAT ROADCOIMBATORE	sunarc@md2.vsnl.net.in	0422 - 822232		
GVW02	WELDING WIRE	80291	Bharat Heavy Electricals Limited ,T	TiruvaramburTrichy		
GVW03	WELDING ELECTRODE OT	80291	Bharat Heavy Electricals Limited ,T	TiruvaramburTrichy		
GVW04	COBALT POWDER	80291	Bharat Heavy Electricals Limited ,T	TiruvaramburTrichy		
GVWFX	WELDING FLUX	10785	ADOR WELDING LIMITED	CORPORATE MARKETING OFFICE,P.B. NO. 2, CHINCHWAD,PUNE	acegasindia@gamail.com	
		10015	ANITA FLUXES ALLOY SPECIALITY	24, 3RD PHASEPEENYA INDUSTRIAL ESTATEBANGALOREBANGALORE		080/ 839 4411
MIGA1	GMAW WIRE ER80S-B3L	20563	BOHLER SCHWEISSTECHNNIK	UNIONSTRASSE-1,D-59067 HAMM,DEUTSCHLAND GmbH.,GERMANY		
		20047	KANEMATSU TRADING CORPORATION	6th FLOOR,AKEBONO NIHONBASHI BLDG,19 - 5,NIHONBASHIKOAMI-CHO,CHUO - KU, TOKYO, 103 - 0016.	nikko-bocki@kgt.kanematsu.co.jp	81 3 5283 3680

**SECTION - VIII
LIST OF APPROVED VENDORS**

1) WELDING CONSUMABLES SUPPLIERS LIST

Mat Group	Material Group Description	Vendor No	Vendor Name	Vendor Address	EMAIL	PHONE1
		21411	METRODE PRODUCTS LIMITED,	HANWORTH LANE,CHERTESSY,SURREY KT169LL,		
		22391	AIR-LIQUIDE WELDING FRANCE,	13,RUE D'EPLUCHES-BP70024 SAINT-OUEN I'AUMONE,95315 CERGY PONTOISE CEDEX	jean-paul.shmitt@airliquide.com	1342 13480
MIGA2	GTAW WIRE FOR T92	20563	BOHLER SCHWEISSTECHNNIK	UNIONSTRASSE-1,D-59067 HAMM,DEUTSCHLAND GmbH.,GERMANY		
		21411	METRODE PRODUCTS LIMITED,	HANWORTH LANE,CHERTESSY,SURREY KT169LL,		
MIGA4	ER80S-B2 BPGMAW WIRE	21411	METRODE PRODUCTS LIMITED,	HANWORTH LANE,CHERTESSY,SURREY KT169LL,		
		10081	ESAB INDIA LTD	KARUMUTTU CENTRE, 6TH FLOORNEW NO.634(OLD NO.498)ANNA SALAI, NANDANAM,CHENNAI-35CHENNAI	jagdeesh.ds@esab.co.in	044-826 9343
MIGN1	GMAWWIRE ERNiCRFe-7A	21991	SPECIAL METALS WELDING PRODUCTS	1401,BURRIS ROAD,NEWTON,NORTH COROLINA 28658	rphillips@smwpc.com	828-465-0352
		20047	KANEMATSU TRADING CORPORATION	6th FLOOR,AKEBONO NIHONBASHI BLDG,19 - 5,NIHONBASHIKOAMI-CHO,CHUO - KU, TOKYO, 103 - 0016.	nikko-bocki@kgt.kanematsu.co.jp	81 3 5283 3680
MIGS1	GMW WIRE ER308H	20130	ALCONIX CORPORATION	SANNO PARK TOWER,12TH FLOOR,2-11-1 NAGATA-CHO,CHIYODA-KU,TOKYO ,JAPAN	Inamori.khei@alconix.com	
		20067	UTP SCHWEISS MATERIAL GMBH & CO	ELSASSER STR 10D-79189, BAD KROZINGENGERMANY.		49(0) 07633 / 40
		20047	KANEMATSU TRADING CORPORATION	6th FLOOR,AKEBONO NIHONBASHI BLDG,19 - 5,NIHONBASHIKOAMI-CHO,CHUO - KU, TOKYO, 103 - 0016.	nikko-bocki@kgt.kanematsu.co.jp	81 3 5283 3680
MIGS2	GMAW WIRE ER309LSi	20130	ALCONIX CORPORATION	SANNO PARK TOWER,12TH FLOOR,2-11-1 NAGATA-CHO,CHIYODA-KU,TOKYO ,JAPAN	Inamori.khei@alconix.com	
		20047	KANEMATSU TRADING CORPORATION	6th FLOOR,AKEBONO NIHONBASHI BLDG,19 - 5,NIHONBASHIKOAMI-CHO,CHUO - KU, TOKYO, 103 - 0016.	nikko-bocki@kgt.kanematsu.co.jp	81 3 5283 3680
		20067	UTP SCHWEISS MATERIAL GMBH & CO	ELSASSER STR 10D-79189, BAD KROZINGENGERMANY.		49(0) 07633 / 40
		22391	AIR-LIQUIDE WELDING FRANCE,	13,RUE D'EPLUCHES-BP70024 SAINT-OUEN I'AUMONE,95315 CERGY PONTOISE CEDEX	jean-paul.shmitt@airliquide.com	1342 13480
		22391	AIR-LIQUIDE WELDING FRANCE,	13,RUE D'EPLUCHES-BP70024 SAINT-OUEN I'AUMONE,95315 CERGY PONTOISE CEDEX	jean-paul.shmitt@airliquide.com	1342 13480
		20130	ALCONIX CORPORATION	SANNO PARK TOWER,12TH FLOOR,2-11-1 NAGATA-CHO,CHIYODA-KU,TOKYO ,JAPAN	Inamori.khei@alconix.com	

**SECTION - VIII
LIST OF APPROVED VENDORS**

1) WELDING CONSUMABLES SUPPLIERS LIST

Mat Group	Material Group Description	Vendor No	Vendor Name	Vendor Address	EMAIL	PHONE1
MIGS3	GMAW WIRE ER309L	20047	KANEMATSU TRADING CORPORATION	6th FLOOR,AKEBONO NIHONBASHI BLDG,19 - 5,NIHONBASHIKOAMI-CHO,CHUO - KU, TOKYO, 103 - 0016.	nikko-bocki@kgt.kanematsu.co.jp	81 3 5283 3680
		20067	UTP SCHWEISS MATERIAL GMBH & CO	ELSASSER STR 10D-79189, BAD KROZINGENGERMANY.		49(0) 07633 / 40
MIGW1	ER 70S-A1 GMAW WIRE	20047	KANEMATSU TRADING CORPORATION	6th FLOOR,AKEBONO NIHONBASHI BLDG,19 - 5,NIHONBASHIKOAMI-CHO,CHUO - KU, TOKYO, 103 - 0016.	nikko-bocki@kgt.kanematsu.co.jp	81 3 5283 3680
		20011	BOHLER SCHWEISSTECHNIK AUSTRIA	WERK DEUCHENDORF,A 8605, KAPPENBERG, POSTFACH - 9,AUSTRIA.AUSTRIA.		0043/3862301
		21411	METRODE PRODUCTS LIMITED,	HANWORTH LANE,CHERTESSY,SURREY KT169LL,		
		20563	BOHLER SCHWEISSTECHNIK	UNIONSTRASSE-1,D-59067 HAMM,DEUTSCHLAND GmbH.,GERMANY		
MIGW2	ER 80S-B2 GMAW WIRE	20047	KANEMATSU TRADING CORPORATION	6th FLOOR,AKEBONO NIHONBASHI BLDG,19 - 5,NIHONBASHIKOAMI-CHO,CHUO - KU, TOKYO, 103 - 0016.	nikko-bocki@kgt.kanematsu.co.jp	81 3 5283 3680
		21411	METRODE PRODUCTS LIMITED,	HANWORTH LANE,CHERTESSY,SURREY KT169LL,		
		10774	D&H SECHERON ELECTRODES PVT LTD.	P.B.NO.344-46,INDL.ESTATE,KILAMAIDANINDORE	sales@dhsecheron.net	0731-4229222
MIGW3	ER 90S-B3 GMAW WIRE	20047	KANEMATSU TRADING CORPORATION	6th FLOOR,AKEBONO NIHONBASHI BLDG,19 - 5,NIHONBASHIKOAMI-CHO,CHUO - KU, TOKYO, 103 - 0016.	nikko-bocki@kgt.kanematsu.co.jp	81 3 5283 3680
		20563	BOHLER SCHWEISSTECHNIK	UNIONSTRASSE-1,D-59067 HAMM,DEUTSCHLAND GmbH.,GERMANY		
		21461	INDUSTRIA NAZIONALE ELETTRODI S.p.A	Via.FACCA 10,CITTADELLA, 35013ITALY.		
		21411	METRODE PRODUCTS LIMITED,	HANWORTH LANE,CHERTESSY,SURREY KT169LL,		
MIGW4	WELDG.WIRE-MIG ER347	22391	AIR-LIQUIDE WELDING FRANCE,	13,RUE D'EPLUCHES-BP70024 SAINT-OUEN l'AUMONE,95315 CERGY PONTOISE CEDEX	jean-paul.shmitt@airliquide.com	1342 13480
		11784	VENUS WIRE INDUSTRIES PVT LTD	19, RAGHUVANSHI MILL COMPOUNDS.B.MARG, LOWER PARELMUMBAI	sales@venuswires.com	022 - 4978840
		21411	METRODE PRODUCTS LIMITED,	HANWORTH LANE,CHERTESSY,SURREY KT169LL,		
		20047	KANEMATSU TRADING CORPORATION	6th FLOOR,AKEBONO NIHONBASHI BLDG,19 - 5,NIHONBASHIKOAMI-CHO,CHUO - KU, TOKYO, 103 - 0016.	nikko-bocki@kgt.kanematsu.co.jp	81 3 5283 3680

**SECTION - VIII
LIST OF APPROVED VENDORS**

1) WELDING CONSUMABLES SUPPLIERS LIST

Mat Group	Material Group Description	Vendor No	Vendor Name	Vendor Address	EMAIL	PHONE1
MIGW5	WELDG.WIRE-MIG ERNIC	22391	AIR-LIQUIDE WELDING FRANCE,	13,RUE D'EPLUCHES-BP70024 SAINT-OUEN I'AUMONE,95315 CERGY PONTOISE CEDEX	jean-paul.shmitt@airliquide.com	1342 13480
		21411	METRODE PRODUCTS LIMITED,	HANWORTH LANE,CHERTESSY,SURREY KT169LL,		
		20047	KANEMATSU TRADING CORPORATION	6th FLOOR,AKEBONO NIHONBASHI BLDG,19 - 5,NIHONBASHIKOAMI-CHO,CHUO - KU, TOKYO, 103 - 0016.	nikko-bocki@kgt.kanematsu.co.jp	81 3 5283 3680
		20067	UTP SCHWEISS MATERIAL GMBH & CO	ELSASSER STR 10D-79189, BAD KROZINGENGERMANY.		49(0) 07633 / 40
MIGW6	WELDG.WIRE-MIG ER90S	20563	BOHLER SCHWEISSTECHNIK	UNIONSTRASSE-1,D-59067 HAMM,DEUTSCHLAND GmbH.,GERMANY		
		22391	AIR-LIQUIDE WELDING FRANCE,	13,RUE D'EPLUCHES-BP70024 SAINT-OUEN I'AUMONE,95315 CERGY PONTOISE CEDEX	jean-paul.shmitt@airliquide.com	1342 13480
		21411	METRODE PRODUCTS LIMITED,	HANWORTH LANE,CHERTESSY,SURREY KT169LL,		
		20011	BOHLER SCHWEISSTECHNIK AUSTRIA	WERK DEUCHENDORF,A 8605, KAPPENBERG, POSTFACH - 9,AUSTRIA.AUSTRIA.		0043/3862301
		91270	VEEPEES INDIA,	C-52, 4TH AVENUE ROAD,GUINDY INDUSTRIAL ESTATE,GUINDY.CHENNAI	veepeesindia@gmail.com	044-43534354
		14428	SHAKUNT ENTERPRISES PRIVATE LIMITED	G.T.ROADSANWALKA BHAWANMILLER GANJLUDHIANA	shakunt@satyam.net.in	161 2538323
		18705	MODI HITECH INDIA LTD.,	1400,MODI TOWER98,NEHRU PLACE,NEW DELHI	gmmelectrode@gmail.com	011 4250 4577
		16661	KLINWELD WIRES PVT. LTD.,	207,TIMMY ARCADE,MAKWANA NAKA, ANDHERI (EAST)MUMBAI	wires@vsnl.net	022 28504848
		17841	PRASHANTH CYLINDERS PVT. LTD.,	35-B,VEERASANDRA INDL. ESTATE,19th K.M.HOSUR ROAD,ELECTRONIC CITY POST,BANGALORE		
		17842	PRECISION DRAWEL PVT., LTD.,	KHASARA NO.221&222/2,VILLAGE TEKADI,TAH. PARSEONI,NAGPUR		
		16548	WELD EXCEL INDIA LTD.,	D-230,PHASE VII,FOCAL POINT,LUDHIANA		
		11288	JAGSHAAN INDUSTRIES	94 FRIENDS COLONYKATOL ROADNAGPUR	jagshaan@nagpur.dot.net.in	0712 - 581557
		10758	ALPHA ARC INDUSTRIES,	B-5,SECTOR A5/6 TRONICA CITYLONIGHAZIABAD, UP	alphaarc@yahoo.com	0 99114 41441
		16662	NATIONAL ENGINEERING ENTERPRISES,	C-9,1st PHASE,INDUSTRIAL AREA,ADITYAPUR,JAMSHEDPUR	nationaljsr@redifmail.com	0657 6539875
		10774	D&H SECHERON ELECTRODES PVT LTD.	P.B.NO.344-46,INDL.ESTATE,KILAMAIDANINDORE	sales@dhsecheron.net	0731-4229222
		13763	CLASSIC ELECTRODES (INDIA) LTD.,	1, BONFIELD LANE2 ND FLOORKOLKATA	classicelectrodes@yahoo.co.in	033 22429581

**SECTION - VIII
LIST OF APPROVED VENDORS**

1) WELDING CONSUMABLES SUPPLIERS LIST

Mat Group	Material Group Description	Vendor No	Vendor Name	Vendor Address	EMAIL	PHONE1
MIGW7	GMAW WIRE ER70S-6	13743	UNIQUE WELDING PRODUCTS PVT.LTD.,	PLOT NO.1205,G.I.D.C. PHASE-IVVITTHAL UDYOGNAGAR,ANAND-388121GUJARAT	ump_vvn@rediffmail.com	02692-236 092...
		11528	RAAJRATNA ELECTRODES LTD	11, SONAROOPA, OPP.LALBANGLOWC.G.ROAD, NAVARANGPURA AHMEDABAD	mktg@gnahd-rel.global.net.in	079 - 6445258
		14575	WELD ALLOY PRODUCTS,	C - 33, SECTOR - IV, NOIDANOIDA DIST.GAUTAM BUDH NAGAR (UP)	wap2005@airtelmail.in	0120-2557183
		17644	VARUN ELECTRODES PVT. LTD.,	H-56,INDUSTRIAL AREA,PANIPAT	kapoor@varunelectrodes.com	0180 2653085
		10737	SRI DHARAANI STEEL,	1060/463,SIVAKASI- VIRUDHUNAGARROAD,THIRUTHANGAL- 626130VIRUDHUNAGAR DIST.	wire@sridharaanisteel.com	98943-88857
		16575	STANDARD WIRE PRODUCTS	219, SIDCO INDUSTRIAL ESTATE,AMBATTUR,CHENNAI		044 26254946
		17813	K.M.CROWN WELDING CONSUMABLES PVT.,	BLOCK NO.16A,16B & 17A,INDUSTRIAL AREA NO.1,A.B.ROAD,DEWAS	kmcrownwelding@dataone.com	07272 259384578
		13911	ROYAL ARC ELECTRODES PVT. LTD	ROYAL HOUSE, PLOT NO.26,VILLAGE VALIV,VASAI (EAST)THANE	royalarc@vsnl.com	0250 2480520
		13693	RASI ELECTRODES LTD.,	21, RAJA ANNAMALAI ROAD,FLAT NO A / 14, THIRD FLOOR,CHENNAI	rele@airtelmail.in	044 26424523
		17814	CALCUTTA ELECTRODES PVT. LTD.,	SARDAR PATEL TIMBER MARKET,BHANPURI,RAIPUR	calcutta_electrodes2006@yahoo.com	0771 4090615
		13986	B&H ELECTRODES PVT. LTD,	VILLAGE SAIDPURA, BARWALA ROAD,DERABASSI,MOHALI		
		15085	VOLTARC ELECTRODES (P) LTD,	10-77, FIRST MAIN,ROYAL NAGAR,H.O.SURYAJYOTHI,R.C.ROAD, P.B.NO.33,TIRUPATHI	voltarc@rediffmail.com	0877 2241462
		14455	WIRE AND WIRE PRODUCTS	SIDCO INDUSTRIAL ESTATEAMBATTURCHENNAI	www@vsnl.net	044 26242378
		15810	NOUVEAUX INDUSTRIES (P) LTD.,	NO.2,SOWDAMBIGA NAGARTIRUPUR ROAD.KANGAYAM		
		14340	NALLI ARC INDUSTRIE,	SF NO. 340,NALLIPALAYAM,PADIYUR POST,KANGAYAM TALUKERODE Dt.	nalliar@yaho.com	04257 245185
		13906	MARUTI WELD LIMITED,	I-1, KIRTI NAGARNEW DELHI	marutiweld@marutiweld.com	25913411
		15101	PRECISION WELDARC LTD,	49,B.T. ROAD, PANIHATI24,PARGANAS (NORTH)KOLKATA.	pwires@yahoo.co.in	033 25634753
15100	MANTEK WIRES	24,SIDCO INDUSTRIAL ESTATE,P.VADUGAPALAYAM,PALLADAMCOIMBAT ORE				

**SECTION - VIII
LIST OF APPROVED VENDORS**

1) WELDING CONSUMABLES SUPPLIERS LIST

Mat Group	Material Group Description	Vendor No	Vendor Name	Vendor Address	EMAIL	PHONE1
		16166	EVERSHINE WIRES	178/2-A3, THURAIYUR ROAD,PULIVALAM,MUSIRI TALUK,TRICHY	evershinewires@rediffmail.com	04327 235527
		13549	ATHARVE WELDING TECHNOLOGIES (INDIA	PVT.LTD.,A 192,M.I.D.C.CHINCHOLI,SOLAPUR	atharv.wt@hotmail.com	0217-273 7029
		10081	ESAB INDIA LTD	KARUMUTTU CENTRE, 6TH FLOORNEW NO.634(OLD NO.498)ANNA SALAI, NANDANAM,CHENNAI-35CHENNAI	jagdeesh.ds@esab.co.in	044-826 9343
		11378	MAILAM INDIA LIMITED	MAILAM MAIN ROAD,SEDARAPET,PONDICHERRY	mailam@mailanindia.com	0413-2677311
		14791	ANAND ARC LTD.,	NO.22(OLD.31),RAILWAY COLONY,III STREET ,AMINJIKARAI,CHENNAI		044 23746379
		10785	ADOR WELDING LIMITED	CORPORATE MARKETING OFFICE,P.B. NO. 2, CHINCHWAD,PUNE	acegasindia@gamail.com	
		13487	MAGNARC ELECTRODES PVT.LTD.,	PENDUTHIVISAGAPATNAM	magnarc@hotmail.com	0891-276 4381...
		13211	D&H INDIA LIMITED	PLOT 'A', SECTOR 'A'INDUSTRIAL AREA,SANWER ROADINDORE	dhindia@sancharnet.in	0731-4273501-...
		14458	M W WIRETECK PVT. LTD.	GF-9, GURU ARJUN DEV BHAWAN,RANJIT NAGAR COM. CMPLX,NEW DELHI.	wire@wireteck.in	011 4540 7712
		13690	GEE LIMITED,	PLOT E-1, ROAD NO. 7,WAGLE INDUSTRIAL ESTATETHANE		
MIGW8	GMAW WIRE ER80S-G	21411	METRODE PRODUCTS LIMITED,	HANWORTH LANE,CHERTESSY,SURREY KT169LL,		
		20047	KANEMATSU TRADING CORPORATION	6th FLOOR,AKEBONO NIHONBASHI BLDG,19 - 5,NIHONBASHIKOAMI-CHO,CHUO - KU, TOKYO, 103 - 0016.	nikko-bocki@kgt.kanematsu.co.jp	81 3 5283 3680
MIGW9	GMAW WIRE ER90S-G	21411	METRODE PRODUCTS LIMITED,	HANWORTH LANE,CHERTESSY,SURREY KT169LL,		
		20563	BOHLER SCHWEISSTECHNNIK	UNIONSTRASSE-1,D-59067 HAMM,DEUTSCHLAND GmbH.,GERMANY		
		20047	KANEMATSU TRADING CORPORATION	6th FLOOR,AKEBONO NIHONBASHI BLDG,19 - 5,NIHONBASHIKOAMI-CHO,CHUO - KU, TOKYO, 103 - 0016.	nikko-bocki@kgt.kanematsu.co.jp	81 3 5283 3680
MIGWA	GMWA WIRE FOR T23.	20130	ALCONIX CORPORATION	SANNO PARK TOWER,12TH FLOOR,2-11-1 NAGATA-CHO,CHIYODA-KU,TOKYO ,JAPAN	Inamori.khei@alconix.com	
		20047	KANEMATSU TRADING CORPORATION	6th FLOOR,AKEBONO NIHONBASHI BLDG,19 - 5,NIHONBASHIKOAMI-CHO,CHUO - KU, TOKYO, 103 - 0016.	nikko-bocki@kgt.kanematsu.co.jp	81 3 5283 3680
		21411	METRODE PRODUCTS LIMITED,	HANWORTH LANE,CHERTESSY,SURREY KT169LL,		

**SECTION - VIII
LIST OF APPROVED VENDORS**

1) WELDING CONSUMABLES SUPPLIERS LIST

Mat Group	Material Group Description	Vendor No	Vendor Name	Vendor Address	EMAIL	PHONE1
P91FL	WELDING FLUX-P91	22391	AIR-LIQUIDE WELDING FRANCE,	13,RUE D'EPLUCHES-BP70024 SAINT-OUEN I'AUMONE,95315 CERGY PONTOISE CEDEX	jean-paul.shmitt@airliquide.com	1342 13480
		20047	KANEMATSU TRADING CORPORATION	6th FLOOR,AKEBONO NIHONBASHI BLDG,19 - 5,NIHONBASHIKOAMI-CHO,CHUO - KU, TOKYO, 103 - 0016.	nikko-bocki@kgt.kanematsu.co.jp	81 3 5283 3680
		10081	ESAB INDIA LTD	KARUMUTTU CENTRE, 6TH FLOORNEW NO.634(OLD NO.498)ANNA SALAI, NANDANAM,CHENNAI-35CHENNAI	jagdeesh.ds@esab.co.in	044-826 9343
		20563	BOHLER SCHWEISSTECHNNIK	UNIONSTRASSE-1,D-59067 HAMM,DEUTSCHLAND GmbH.,GERMANY		
		20011	BOHLER SCHWEISSTECHNIK AUSTRIA	WERK DEUCHENDORF,A 8605, KAPPENBERG, POSTFACH - 9,AUSTRIA.AUSTRIA.		0043/3862301
P92FL	SAWFLUX FOR SA335P92	20563	BOHLER SCHWEISSTECHNNIK	UNIONSTRASSE-1,D-59067 HAMM,DEUTSCHLAND GmbH.,GERMANY		
SAWA1	SAWWIRE FOR SA335P92	21411	METRODE PRODUCTS LIMITED,	HANWORTH LANE,CHERTESY,SURREY KT169LL,		
		20563	BOHLER SCHWEISSTECHNNIK	UNIONSTRASSE-1,D-59067 HAMM,DEUTSCHLAND GmbH.,GERMANY		
SSOFL	WELD:SS-OVERLAY FLUX	10785	ADOR WELDING LIMITED	CORPORATE MARKETING OFFICE,P.B. NO. 2, CHINCHWAD,PUNE	acegasindia@gamail.com	
		10015	ANITA FLUXES ALLOY SPECIALITY	24, 3RD PHASEPEENYA INDUSTRIAL ESTATEBANGALOREBANGALORE		080/ 839 4411
		13833	SUN FLUX,	PUTHUKUDI ROAD,RAYAMUNDANPATTITANJORE		
		15082	ROYAL WELDING WIRES PVT. LTD.,	7,KARANAI PUDUCHERRY VILLAGE,VIA.URAPAKKAM,KANCHIPURAM DIST,	royal@royalwires.co.in	044-3741 1610
		12184	LAKSHMI CHEMICAL INDUSTRIES	D-52, DEVELOPED PLOT ESTATETHUVAKUDITIRUCHIRAPALLI	lakshmi.chem@yahoo.com	9842550538
		13534	RUPA INDUSTRIES,	2-2-105 to 180/10,GANESH CHAMBERSRANIGUNJ,SECUNDERABAD	rupaent@vsnl.net	040-2771 3714
		13484	OSCAR AUTO FLUX,	3/216,INAMKULATHUR ROAD,AMMAPETTAI,POOLANGULATHUPATTY(PO), TRICHY	oscarautoflux@gmail.com	0431-2914567
		13691	MANTEK WELDAIDFLUX CO.	32, FIRST STREETGANDHI NAGARTHIRUVERUMBURTIRUCHIRAPPALLI	mantek@eth.net	2501540
		14593	R.M.H.CHEMICAL INDUSTRIES	C-12-A,DEVELOPED PLOTS ESTATE,THUVAKUDY,TIRUCHIRAPALLY	rmhfbbricators@vsnl.net	2500498

**SECTION - VIII
LIST OF APPROVED VENDORS**

1) WELDING CONSUMABLES SUPPLIERS LIST

Mat Group	Material Group Description	Vendor No	Vendor Name	Vendor Address	EMAIL	PHONE1
STRFL	SAW FLUX STRUCT.WELD	14309	S.CHEMS & ALLIED PRODUCERS PVT LIMI	PLOT NO.197,JANKIDEVI SCHOOL ROAD,MHADA BUNGALOW CSHEME,Nr. VARSOVA TEL. EXCHANGE,ANDHERI (W)MUMBAI	s chems@yahoo.co.in	022 26368557
		11701	SUPER WELD PRODUCTS	91/1 THINNANUR ROADPULIVALAM,MUSIRI TKTIRUCHIRAPALLI		0431 - 765626
		19114	WELMET TECHNOLOGIES PVT. LTD.,	34,P.N.MAIDU INDUSTRIAL ESTATE,M.I.D.C. HINGNA,NAGPUR		
		10785	ADOR WELDING LIMITED	CORPORATE MARKETING OFFICE,P.B. NO. 2, CHINCHWAD,PUNE	acegasindia@gamail.com	
		15099	THERMIT ALLOYS (P) LTD,	PLOT NO.7, INDUSTRIAL ESTATE,B.H.ROAD,SHIMOGA	thermit@vsnl.net	08182 250431
		17381	NOUVEOFLUX CHEMICAL COMPANY	1 /B 83 & 85, TIRUPUR ROADKANGAYAM		
		13211	D&H INDIA LIMITED	PLOT 'A', SECTOR 'A'INDUSTRIAL AREA,SANWER ROADINDORE	dhindia@sancharnet.in	0731-4273501-...
		11712	TAPADIA ENGINEERS & TRADERS P.LTD.	2, INDUSTRIAL ESTATE,BHANPURI, CHATTISGARH.RAIPUR	tet_tgirpr@rediffmail.com	0770 - 4090636
		13486	A V WELDTECH PVT.LTD.,	NO.206/12,CIVIL LINES,NEAR G.P.O. SQUARENAGPUR.	products@aveasyweld.com	0712-252 1727
		11288	JAGSHAAN INDUSTRIES	94 FRIENDS COLONYKATOL ROADNAGPUR	jagshaan@nagpur.dot.net.in	0712 - 581557
		15084	DWEKAM ELECTRODES LTD,	TALAWALI CHANDA,A.B.ROAD, P.O.MANGILAINDORE (MP)	vk.khandelwal@dwekam.org	0731 422 9500...
		15085	VOLTARC ELECTRODES (P) LTD,	10-77, FIRST MAIN,ROYAL NAGAR,H.O.SURYAJYOTHI,R.C.ROAD, P.B.NO.33,TIRUPATHI	voltarc@rediffmail.com	0877 2241462
		19695	SUBMER FLUX TECHNOLOGIES,	178/2A1,THURAIYUR ROAD,PULIVALAM,TRICHY		
		10466	SUN AUTO WELD INDUSTRIES,	SF NO.137/2,GANAPATHY NAGAR,ARIYAMANGALAM,TRICHY		
		19735	RENUKA FLUXES COMPANY,	3-227 - A, SEMMANKUDAL (PO),OMALUR TALUK,SALEM		04290 313331
		10081	ESAB INDIA LTD	KARUMUTTU CENTRE, 6TH FLOORNEW NO.634(OLD NO.498)ANNA SALAI, NANDANAM,CHENNAI-35CHENNAI	jagdeesh.ds@esab.co.in	044-826 9343
14791	ANAND ARC LTD.,	NO.22(OLD.31),RAILWAY COLONY,III STREET,AMINJIKARAI,CHENNAI		044 23746379		
15101	PRECISION WELDARC LTD,	49,B.T. ROAD, PANIHATI24,PARGANAS (NORTH)KOLKATA.	pwires@yahoo.co.in	033 25634753		

**SECTION - VIII
LIST OF APPROVED VENDORS**

1) WELDING CONSUMABLES SUPPLIERS LIST

Mat Group	Material Group Description	Vendor No	Vendor Name	Vendor Address	EMAIL	PHONE1
		11528	RAAJRATNA ELECTRODES LTD	11, SONAROOPA, OPP.LALBANGLOWC.G.ROAD, NAVARANGPURA AHMEDABAD	mktg@gnaht-rel.global.net.in	079 - 6445258
TIGA1	GTAW ROD - T92 / P92	21411	METRODE PRODUCTS LIMITED,	HANWORTH LANE,CHERTESSY,SURREY KT169LL,		
		20563	BOHLER SCHWEISSTECHNNIK	UNIONSTRASSE-1,D-59067 HAMM,DEUTSCHLAND GmbH.,GERMANY		
TIGA2	GTAW ROD ER80S-B3L	20563	BOHLER SCHWEISSTECHNNIK	UNIONSTRASSE-1,D-59067 HAMM,DEUTSCHLAND GmbH.,GERMANY		
		20047	KANEMATSU TRADING CORPORATION	6th FLOOR,AKEBONO NIHONBASHI BLDG,19 - 5,NIHONBASHIKOAMI-CHO,CHUO - KU, TOKYO, 103 - 0016.	nikko-bocki@kgt.kanematsu.co.jp	81 3 5283 3680
		21411	METRODE PRODUCTS LIMITED,	HANWORTH LANE,CHERTESSY,SURREY KT169LL,		
		22391	AIR-LIQUIDE WELDING FRANCE,	13,RUE D'EPLUCHES-BP70024 SAINT-OUEN L'AUMONE,95315 CERGY PONTOISE CEDEX	jean-paul.shmitt@airliquide.com	1342 13480
TIGS1	GTAW ROD ER316H	20067	UTP SCHWEISS MATERIAL GMBH & CO	ELSASSER STR 10D-79189, BAD KROZINGENGERMANY.		49(0) 07633 / 40
		20047	KANEMATSU TRADING CORPORATION	6th FLOOR,AKEBONO NIHONBASHI BLDG,19 - 5,NIHONBASHIKOAMI-CHO,CHUO - KU, TOKYO, 103 - 0016.	nikko-bocki@kgt.kanematsu.co.jp	81 3 5283 3680
		20130	ALCONIX CORPORATION	SANNO PARK TOWER,12TH FLOOR,2-11-1 NAGATA- CHO,CHIYODA-KU,TOKYO ,JAPAN	Inamori.khei@alconix.com	
TIGS2	GTAW ROD ER309L	20047	KANEMATSU TRADING CORPORATION	6th FLOOR,AKEBONO NIHONBASHI BLDG,19 - 5,NIHONBASHIKOAMI-CHO,CHUO - KU, TOKYO, 103 - 0016.	nikko-bocki@kgt.kanematsu.co.jp	81 3 5283 3680
		20130	ALCONIX CORPORATION	SANNO PARK TOWER,12TH FLOOR,2-11-1 NAGATA- CHO,CHIYODA-KU,TOKYO ,JAPAN	Inamori.khei@alconix.com	
		20067	UTP SCHWEISS MATERIAL GMBH & CO	ELSASSER STR 10D-79189, BAD KROZINGENGERMANY.		49(0) 07633 / 40
		22391	AIR-LIQUIDE WELDING FRANCE,	13,RUE D'EPLUCHES-BP70024 SAINT-OUEN L'AUMONE,95315 CERGY PONTOISE CEDEX	jean-paul.shmitt@airliquide.com	1342 13480
TIGS3	GTAW ROD ER308H	20130	ALCONIX CORPORATION	SANNO PARK TOWER,12TH FLOOR,2-11-1 NAGATA- CHO,CHIYODA-KU,TOKYO ,JAPAN	Inamori.khei@alconix.com	
		20047	KANEMATSU TRADING CORPORATION	6th FLOOR,AKEBONO NIHONBASHI BLDG,19 - 5,NIHONBASHIKOAMI-CHO,CHUO - KU, TOKYO, 103 - 0016.	nikko-bocki@kgt.kanematsu.co.jp	81 3 5283 3680
		20067	UTP SCHWEISS MATERIAL GMBH & CO	ELSASSER STR 10D-79189, BAD KROZINGENGERMANY.		49(0) 07633 / 40

**SECTION - VIII
LIST OF APPROVED VENDORS**

1) WELDING CONSUMABLES SUPPLIERS LIST

Mat Group	Material Group Description	Vendor No	Vendor Name	Vendor Address	EMAIL	PHONE1
TIGW1	ER 70S-A1 GTAW ROD	10774	D&H SECHERON ELECTRODES PVT LTD.	P.B.NO.344-46,INDL.ESTATE,KILAMAIDANINDORE	sales@dnhsecheron.net	0731-4229222
		20563	BOHLER SCHWEISSTECHNNIK	UNIONSTRASSE-1,D-59067 HAMM,DEUTSCHLAND GmbH.,GERMANY		
		20047	KANEMATSU TRADING CORPORATION	6th FLOOR,AKEBONO NIHONBASHI BLDG,19 - 5,NIHONBASHIKOAMI-CHO,CHUO - KU, TOKYO, 103 - 0016.	nikko-bocki@kgt.kanematsu.co.jp	81 3 5283 3680
		15083	MARUTHI ELECTRODES (P) LTD.,	138,5TH FLOOR,MARUTHI TOWERAIRPORT ROAD,KODIHALU,BANGALORE	meplelec@bgl.vsnl.net.in	080 25275848
		21411	METRODE PRODUCTS LIMITED,	HANWORTH LANE,CHERTESSY,SURREY KT169LL,		
		20011	BOHLER SCHWEISSTECHNIK AUSTRIA	WERK DEUCHENDORF,A 8605, KAPPENBERG, POSTFACH - 9,AUSTRIA.AUSTRIA.		0043/3862301
		22456	I.A.BARNES & CO. LTD,	UNIT E,GUNNELS WOOD PARK,GUNNELS WOOD ROAD,STEVENAGE, HERTFORDSHIRE, SG1 2BH,		
TIGW2	ER 80S-B2 GTAW ROD	20047	KANEMATSU TRADING CORPORATION	6th FLOOR,AKEBONO NIHONBASHI BLDG,19 - 5,NIHONBASHIKOAMI-CHO,CHUO - KU, TOKYO, 103 - 0016.	nikko-bocki@kgt.kanematsu.co.jp	81 3 5283 3680
		10774	D&H SECHERON ELECTRODES PVT LTD.	P.B.NO.344-46,INDL.ESTATE,KILAMAIDANINDORE	sales@dnhsecheron.net	0731-4229222
		21461	INDUSTRIA NAZIONALE ELETTRODI S.p.A	Via.FACCA 10,CITTADELLA, 35013ITALY.		
		21411	METRODE PRODUCTS LIMITED,	HANWORTH LANE,CHERTESSY,SURREY KT169LL,		
TIGW3	ER 90S-B3 GTAW ROD	21461	INDUSTRIA NAZIONALE ELETTRODI S.p.A	Via.FACCA 10,CITTADELLA, 35013ITALY.		
		20047	KANEMATSU TRADING CORPORATION	6th FLOOR,AKEBONO NIHONBASHI BLDG,19 - 5,NIHONBASHIKOAMI-CHO,CHUO - KU, TOKYO, 103 - 0016.	nikko-bocki@kgt.kanematsu.co.jp	81 3 5283 3680
		21411	METRODE PRODUCTS LIMITED,	HANWORTH LANE,CHERTESSY,SURREY KT169LL,		
		20563	BOHLER SCHWEISSTECHNNIK	UNIONSTRASSE-1,D-59067 HAMM,DEUTSCHLAND GmbH.,GERMANY		
TIGW4	WELDG.WIRE-TIG ER347	20067	UTP SCHWEISS MATERIAL GMBH & CO	ELSASSER STR 10D-79189, BAD KROZINGENGERMANY.		49(0) 07633 / 40
		21411	METRODE PRODUCTS LIMITED,	HANWORTH LANE,CHERTESSY,SURREY KT169LL,		
		20047	KANEMATSU TRADING CORPORATION	6th FLOOR,AKEBONO NIHONBASHI BLDG,19 - 5,NIHONBASHIKOAMI-CHO,CHUO - KU, TOKYO, 103 - 0016.	nikko-bocki@kgt.kanematsu.co.jp	81 3 5283 3680

**SECTION - VIII
LIST OF APPROVED VENDORS**

1) WELDING CONSUMABLES SUPPLIERS LIST

Mat Group	Material Group Description	Vendor No	Vendor Name	Vendor Address	EMAIL	PHONE1
		20563	BOHLER SCHWEISSTECHNNIK	UNIONSTRASSE-1,D-59067 HAMM,DEUTSCHLAND GmbH.,GERMANY		
TIGW5	WELDG.WIRE-TIG ERNiC	20067	UTP SCHWEISS MATERIAL GMBH & CO	ELSASSER STR 10D-79189, BAD KROZINGENGERMANY.		49(0) 07633 / 40
		15083	MARUTHI ELECTRODES (P) LTD.,	138,5TH FLOOR,MARUTHI TOWERAIRPORT ROAD,KODIHALU,BANGALORE	meplelec@bgl.vsnl.net.in	080 25275848
		20047	KANEMATSU TRADING CORPORATION	6th FLOOR,AKEBONO NIHONBASHI BLDG,19 - 5,NIHONBASHIKOAMI-CHO,CHUO - KU, TOKYO, 103 - 0016.	nikko-bocki@kgt.kanematsu.co.jp	81 3 5283 3680
		20563	BOHLER SCHWEISSTECHNNIK	UNIONSTRASSE-1,D-59067 HAMM,DEUTSCHLAND GmbH.,GERMANY		
TIGW7	WELDG.WIRE - TIG ER9	20047	KANEMATSU TRADING CORPORATION	6th FLOOR,AKEBONO NIHONBASHI BLDG,19 - 5,NIHONBASHIKOAMI-CHO,CHUO - KU, TOKYO, 103 - 0016.	nikko-bocki@kgt.kanematsu.co.jp	81 3 5283 3680
		22391	AIR-LIQUIDE WELDING FRANCE,	13,RUE D'EPLUCHES-BP70024 SAINT-OUEN L'AUMONE,95315 CERGY PONTOISE CEDEX	jean-paul.shmitt@airliquide.com	1342 13480
		20011	BOHLER SCHWEISSTECHNIK AUSTRIA	WERK DEUCHENDORF,A 8605, KAPPENBERG, POSTFACH - 9,AUSTRIA.AUSTRIA.		0043/3862301
		20563	BOHLER SCHWEISSTECHNNIK	UNIONSTRASSE-1,D-59067 HAMM,DEUTSCHLAND GmbH.,GERMANY		
		21411	METRODE PRODUCTS LIMITED,	HANWORTH LANE,CHERTESSY,SURREY KT169LL,		
TIGW9	ER80S - D2 GTAW ROD	20563	BOHLER SCHWEISSTECHNNIK	UNIONSTRASSE-1,D-59067 HAMM,DEUTSCHLAND GmbH.,GERMANY		
		21411	METRODE PRODUCTS LIMITED,	HANWORTH LANE,CHERTESSY,SURREY KT169LL,		
		20130	ALCONIX CORPORATION	SANNO PARK TOWER,12TH FLOOR,2-11-1 NAGATA-CHO,CHIYODA-KU,TOKYO ,JAPAN	Inamori.khei@alconix.com	
TIGWA	GTAW ROD T23 / P23	20047	KANEMATSU TRADING CORPORATION	6th FLOOR,AKEBONO NIHONBASHI BLDG,19 - 5,NIHONBASHIKOAMI-CHO,CHUO - KU, TOKYO, 103 - 0016.	nikko-bocki@kgt.kanematsu.co.jp	81 3 5283 3680
		21411	METRODE PRODUCTS LIMITED,	HANWORTH LANE,CHERTESSY,SURREY KT169LL,		
		20563	BOHLER SCHWEISSTECHNNIK	UNIONSTRASSE-1,D-59067 HAMM,DEUTSCHLAND GmbH.,GERMANY		
		20130	ALCONIX CORPORATION	SANNO PARK TOWER,12TH FLOOR,2-11-1 NAGATA-CHO,CHIYODA-KU,TOKYO ,JAPAN	Inamori.khei@alconix.com	
TIGWR	GTAW ROD SUPER304H	20563	BOHLER SCHWEISSTECHNNIK	UNIONSTRASSE-1,D-59067 HAMM,DEUTSCHLAND GmbH.,GERMANY		

**SECTION - VIII
LIST OF APPROVED VENDORS**

1) WELDING CONSUMABLES SUPPLIERS LIST

Mat Group	Material Group Description	Vendor No	Vendor Name	Vendor Address	EMAIL	PHONE1
TIGWD	GTAW ROD	20130	ALCONIX CORPORATION	SANNO PARK TOWER,12TH FLOOR,2-11-1 NAGATA-CHO,CHIYODA-KU,TOKYO ,JAPAN	Inamori.khei@alconix.com	
TIGWD	GTAW ROD	20047	KANEMATSU TRADING CORPORATION	6th FLOOR,AKEBONO NIHONBASHI BLDG,19 - 5,NIHONBASHIKOAMI-CHO,CHUO - KU, TOKYO, 103 - 0016.	nikko-bocki@kgt.kanematsu.co.jp	81 3 5283 3680
		21991	SPECIAL METALS WELDING PRODUCTS	1401,BURRIS ROAD,NEWTON,NORTH COROLINA 28658	rphillips@smwpc.com	828-465-0352
WCA08	WELDG.ELECTRODES:SMA	10774	D&H SECHERON ELECTRODES PVT LTD.	P.B.NO.344-46,INDL.ESTATE,KILAMAIDANINDORE	sales@dnhsecheron.net	0731-4229222
		15090	RAJ KESARI ELECTRODES,	35,RAVINDRA NAGAR,(PRATAP NAGAR)UDAIPUR	rajkesari@yahoo.com	0294 2490193
WCA10	WELDG.ELECTRODES:SMA	14040	MANTEK ELECTRODS PRIVATE LTD,	D-74A, DEVELOPED PLOT ESTATE,THUVAKUDITRICHY		2501540
		13690	GEE LIMITED,	PLOT E-1, ROAD NO. 7,WAGLE INDUSTRIAL ESTATETHANE		
		18705	MODI HITECH INDIA LTD.,	1400,MODI TOWER98,NEHRU PLACE,NEW DELHI	gmmelectrode@gmail.com	011 4250 4577
		10774	D&H SECHERON ELECTRODES PVT LTD.	P.B.NO.344-46,INDL.ESTATE,KILAMAIDANINDORE	sales@dnhsecheron.net	0731-4229222
		11227	HONAVAR ELECTRODES PVT. LTD.,	305-309,3RD FLOOR,DAMJI SHAMJI INDUSTRIAL COMPLEX ,9,L.B.S MARG, KURLA(WEST)MUMBAI	hel@vsnl.com	022-25020317
		11378	MAILAM INDIA LIMITED	MAILAM MAIN ROAD,SEDARAPET,PONDICHERRY	mailam@mailanindia.com	0413-2677311
		11420	MODI ARC ELECTRODES CO.	MODINAGARUTTAR PRADESHGHAZIABAD	modiarc@ndb.vsnl.net.in	01232 - 242427
WCA12	WELDG.ELECTRODES:SMA	10774	D&H SECHERON ELECTRODES PVT LTD.	P.B.NO.344-46,INDL.ESTATE,KILAMAIDANINDORE	sales@dnhsecheron.net	0731-4229222
		11227	HONAVAR ELECTRODES PVT. LTD.,	305-309,3RD FLOOR,DAMJI SHAMJI INDUSTRIAL COMPLEX ,9,L.B.S MARG, KURLA(WEST)MUMBAI	hel@vsnl.com	022-25020317
		13690	GEE LIMITED,	PLOT E-1, ROAD NO. 7,WAGLE INDUSTRIAL ESTATETHANE		
		11420	MODI ARC ELECTRODES CO.	MODINAGARUTTAR PRADESHGHAZIABAD	modiarc@ndb.vsnl.net.in	01232 - 242427
		11378	MAILAM INDIA LIMITED	MAILAM MAIN ROAD,SEDARAPET,PONDICHERRY	mailam@mailanindia.com	0413-2677311
		20011	BOHLER SCHWEISSTECHNIK AUSTRIA	WERK DEUCHENDORF,A 8605, KAPPENBERG, POSTFACH - 9,AUSTRIA.AUSTRIA.		0043/3862301

**SECTION - VIII
LIST OF APPROVED VENDORS**

1) WELDING CONSUMABLES SUPPLIERS LIST

Mat Group	Material Group Description	Vendor No	Vendor Name	Vendor Address	EMAIL	PHONE1
WCA23	SMAW ELECTRODE E9015	20047	KANEMATSU TRADING CORPORATION	6th FLOOR,AKEBONO NIHONBASHI BLDG,19 - 5,NIHONBASHIKOAMI-CHO,CHUO - KU, TOKYO, 103 - 0016.	nikko-bocki@kgt.kanematsu.co.jp	81 3 5283 3680
		21411	METRODE PRODUCTS LIMITED,	HANWORTH LANE,CHERTESSY,SURREY KT169LL,		
		22391	AIR-LIQUIDE WELDING FRANCE,	13,RUE D'EPLUCHES-BP70024 SAINT-OUEN I'AUMONE,95315 CERGY PONTOISE CEDEX	jean-paul.shmitt@airliquide.com	1342 13480
		20563	BOHLER SCHWEISSTECHNNIK	UNIONSTRASSE-1,D-59067 HAMM,DEUTSCHLAND GmbH.,GERMANY		
WCA24	SMAW ELECTRD T23/P23	21411	METRODE PRODUCTS LIMITED,	HANWORTH LANE,CHERTESSY,SURREY KT169LL,		
		20047	KANEMATSU TRADING CORPORATION	6th FLOOR,AKEBONO NIHONBASHI BLDG,19 - 5,NIHONBASHIKOAMI-CHO,CHUO - KU, TOKYO, 103 - 0016.	nikko-bocki@kgt.kanematsu.co.jp	81 3 5283 3680
		20130	ALCONIX CORPORATION	SANNO PARK TOWER,12TH FLOOR,2-11-1 NAGATA-CHO,CHIYODA-KU,TOKYO ,JAPAN	Inamori.khei@alconix.com	
WCA25	SMAW ELECD - T92/P92	21411	METRODE PRODUCTS LIMITED,	HANWORTH LANE,CHERTESSY,SURREY KT169LL,		
		20563	BOHLER SCHWEISSTECHNNIK	UNIONSTRASSE-1,D-59067 HAMM,DEUTSCHLAND GmbH.,GERMANY		
WCA26	SMAW ELEC E8018-B3L	10774	D&H SECHERON ELECTRODES PVT LTD.	P.B.NO.344-46,INDL.ESTATE,KILAMAIDANINDORE	sales@dnhsecheron.net	0731-4229222
		11227	HONAVAR ELECTRODES PVT. LTD.,	305-309,3RD FLOOR,DAMJI SHAMJI INDUSTRIAL COMPLEX ,9,L.B.S MARG, KURLA(WEST)MUMBAI	hel@vsnl.com	022-25020317
WCA27	SMAW ELEC E7018-B2L	11227	HONAVAR ELECTRODES PVT. LTD.,	305-309,3RD FLOOR,DAMJI SHAMJI INDUSTRIAL COMPLEX ,9,L.B.S MARG, KURLA(WEST)MUMBAI	hel@vsnl.com	022-25020317
		10774	D&H SECHERON ELECTRODES PVT LTD.	P.B.NO.344-46,INDL.ESTATE,KILAMAIDANINDORE	sales@dnhsecheron.net	0731-4229222
		15080	SUNCRAFT ELECTRODES	BYE PASS ROAD,MUSIRI		04326 60525
		15085	VOLTARC ELECTRODES (P) LTD,	10-77, FIRST MAIN,ROYAL NAGAR,H.O.SURYAJYOTHI,R.C.ROAD, P.B.NO.33,TIRUPATHI	voltarc@rediffmail.com	0877 2241462
		18433	NUCOR WELD(INDIA)PVT.LTD.,	NO.223,KONAPPANA AGRAHARA,ELECTRONIC CITY POST,BANGALORE	nuکورweldinida@yahoo.com	080-2852 2057
		15083	MARUTHI ELECTRODES (P) LTD.,	138,5TH FLOOR,MARUTHI TOWERAIRPORT ROAD,KODIHALU,BANGALORE	mepolec@bgl.vsnl.net.in	080 25275848

**SECTION - VIII
LIST OF APPROVED VENDORS**

1) WELDING CONSUMABLES SUPPLIERS LIST

Mat Group	Material Group Description	Vendor No	Vendor Name	Vendor Address	EMAIL	PHONE1
		11881	FUSION ENGG. PRODUCTS LTD.,	B-16,Vith PHASE, POST.GAMARIA(JAMSHEDPUR)SERAIKELA- KHARSAWAN,GAMARIA	info@fusionweld.co.in	0657-6542444
		13538	WELDCOM ELECTRODES PVT.LTD.,	T-357,ASHIRWAD PALACENR.BHATAR CHAR RASTA,JIVKOR NAGAR,SURAT		0261-305 4555
		13693	RASI ELECTRODES LTD.,	21, RAJA ANNAMALAI ROAD,FLAT NO A / 14, THIRD FLOOR,CHENNAI	rele@airtelmail.in	044 26424523
		15102	SOLARC WELD RODS,	OLD NO.12,NEW NO.14,65th STREET12th AVENUE,ASHOK NAGAR,CHENNAI	soarcweldrods@gmail.com	044-24891173
		15081	ANNAI SIVAKAMI AMMAL INDUSTRIES,	5/1C,M.M.K.COMPLEX,(OPP. TO S.I.T.)ARIYAMANGALAM.TIRUCHIRAPALLY		0431 2441696
		11378	MAILAM INDIA LIMITED	MAILAM MAIN ROAD,SEDARAPET,PONDICHERRY	mailam@mailanindia.com	0413-2677311
		13663	ORION WIRE MANUFACTURING CO.,	POST BOX NO.7,PLOT NO.56A & 44A,GIDC ESTATE,NARNADA NAGAR,BHARUCH	info@sunarcindia.com	02462-246419
		17820	SETH ELECTRODES PVT. LTD.,	SHRIMANT BHAWAN,KHURAI	sepl@sethindia.com	07581 240704
		11380	MALU ELECTRODES PVT.LIMITED	111, RAMAKRISHNA APPARTMENT,CHHAPRU NAGAR SQUARE,CENTRAL AVENUE NAGAR,NAGPUR	meploffice@rediffmail.com	0712 - 2734895
		11420	MODI ARC ELECTRODES CO.	MODINAGARUTTAR PRADESHGHAZIABAD	modiarc@ndb.vsnl.net.in	01232 - 242427
		17661	ALPHA WELDING & ALLIED	#B-10,VEERASANDRA INDUSTRIALESTATE, HOSUR ROAD,BANGALORE		
		17664	ELMARC ELECTRODES PVT. LTD.,	118,SISIDCO INDUSTRIAL ESTATE,AMBATTUR,CHENNAI		
		17813	K.M.CROWN WELDING CONSUMABLES PVT.,	BLOCK NO.16A,16B & 17A,INDUSTRIAL AREA NO.1,A.B.ROAD,DEWAS	kmcrownwelding@dataone.com	07272 259384578
		17812	VICTOR ELECTRODES LIMITED ,	T-1/ 113-114,MANGOLPURI INDUSTRIAL AREA,PHASE - I,NEW DELHI	victor@del2.vsnl.net.in	011 43860025
		17802	SRI VARSHA ELECTRODES,	SHED NO. 55,PHASE V,SIDCO INDUSTRIAL ESTATE,KAKKALUR,THIRUVALLUR DIST.CHENNAI		0 98402 60618
		17643	SUNDEEP ELECTRODES PVT. LTD.,	BULANSHAHAR ROAD,HAPUR		
		17801	JAIN WELDING ELECTRODES PVT. LTD,	G-1-318(C).INDRAPRASTHA INDUSTRIAL AREA,ROAD NO.6,RAJASTHAN,KOTA	info@jainelectrodes.com	0744 2490177
		11227	HONAVAR ELECTRODES PVT. LTD.,	305-309,3RD FLOOR,DAMJI SHAMJI INDUSTRIAL COMPLEX ,9,L.B.S MARG, KURLA(WEST)MUMBAI	hel@vsnl.com	022-25020317

**SECTION - VIII
LIST OF APPROVED VENDORS**

1) WELDING CONSUMABLES SUPPLIERS LIST

Mat Group	Material Group Description	Vendor No	Vendor Name	Vendor Address	EMAIL	PHONE1
WCC01	WELDG.ELECTRODES:SMA	13729	ORANGE ELECTRODES INDUSTRIES,	PLOT NO.9,SHIV SHAKTI LAGHU UDYOGSANKUL,OPP.NEEL ENGG.CO.MUMBAI-NASIK HIGHWAY,ASANGAON	orangeelectrodes@gmail.com	02527-271 995
		13690	GEE LIMITED,	PLOT E-1, ROAD NO. 7,WAGLE INDUSTRIAL ESTATETHANE		
		15087	V.N.C.ELECTRODEES,	3, INDUSTRIAL ESTATE,S.VELLALAPATTIKARUR	kru_vnc@sancharnet.in	04324 242774
		19906	BAGHERWAL ELECTRODES PVT.LTD.,	20-23,VAIBHAV CHAMBER,7/1,USHAGANJ CHHAWANI,INDORE	bagherwal13@yahoo.com	0731-2905067
		13986	B&H ELECTRODES PVT. LTD,	VILLAGE SAIDPURA, BARWALA ROAD,DERABASSI,MOHALI		
		10081	ESAB INDIA LTD	KARUMUTTU CENTRE, 6TH FLOORNEW NO.634(OLD NO.498)ANNA SALAI, NANDANAM,CHENNAI-35CHENNAI	jagdeesh.ds@esab.co.in	044-826 9343
		19875	ABIRAMI ELECTRODES,	SF NO.107-A,SARAVANAMPATTI ROAD,VELLAIKINARU,COIMBATORE	sun_weld@yahoo.com	0422 3232724
		14457	BALAJI ELECTRODES	4A / 1A, N.G. NARAYANASAMY STREET,NEW SIDHAPUDUR (PO),COIMBATORE.	sonyaarc6013@gmail.com	0422 438 7817
		19751	FINE WELD ELECTRODESS INDIA (P)LTD.	2/630,PERUMAL KOIL THOTTAM,VENKATAPURAM (PO),COIMBATORE	fineweldcbe@yahoo.com	0422-6581990/...
		19745	MEGA WELD TECHNOLOGIES,	3/219,AVINASHI ROAD,NEELAMBUR (PO),COIMBATORE	megaweldcbe@yahoo.com	0422-658 1989
		14449	IDEAL ELECTRODES	7 - A, SITRA ROAD,KALAPPATTI,COIMBATORE.	idealelectrode@gmail.com	0422 262 7710
		14447	UPARC ELECTRODES COMPANY.	BEHIND NAV BHARAT INTER COLLEGE,KHASRA No.1, INDIRA PURAM COLONY,PARTAPUR,MEERUT.		0121 244 0203
		10667	EUREKA SYSTEMS AND ELECTRODES P.LTD	11/15A,SELVARAJAPURAM,CHINTHAMANIPUDUR, COIMBATORE	info@eurekaelectrodes@gmail.com	0422-268 7199...
		12893	RUKHMANI ELECTRODES PVT.LTD.,	31,THAKURPUKUR (N.W) ROAD,P.O.BADU,DIST:24 PARGANAS(N)KOLKATA	rukhmanielectrodes@rediffmail.com	033-2526 2039
		14448	BRIGHT WELD TECHNOLOGIES	9 / 9, SAKTHI NAGAR,UPPILIPALAYAM POST,COIMBATORE.	brigtweld13@gmail.com	0422 257 4756
		10785	ADOR WELDING LIMITED	CORPORATE MARKETING OFFICE,P.B. NO. 2, CHINCHWAD,PUNE	acegasindia@gamail.com	
15086	SRI RENGA ELECTRODES (P) LTD,	137/3, GANAPATHY NAGAR,ARIYAMANGALAMTRICHY		0431-25501173		

**SECTION - VIII
LIST OF APPROVED VENDORS**

1) WELDING CONSUMABLES SUPPLIERS LIST

Mat Group	Material Group Description	Vendor No	Vendor Name	Vendor Address	EMAIL	PHONE1
		13911	ROYAL ARC ELECTRODES PVT. LTD	ROYAL HOUSE, PLOT NO.26,VILLAGE VALIV,VASAI (EAST)THANE	royalarc@vsnl.com	0250 2480520
		11528	RAAJRATNA ELECTRODES LTD	11, SONAROOA, OPP.LALBANGLOWC.G.ROAD, NAVARANGPURAAHMEDABAD	mktg@gnahd-rel.global.net.in	079 - 6445258
		17644	VARUN ELECTRODES PVT. LTD.,	H-56,INDUSTRIAL AREA,PANIPAT	kapoor@varunelectrodes.com	0180 2653085
		17814	CALCUTTA ELECTRODES PVT. LTD.,	SARDAR PATEL TIMBER MARKET,BHANPURI,RAIPUR	calcutta_electrodes2006@yahoo.com	0771 4090615
		19111	SPECTRA SUPER ALLOYS LTD,	324 / 325, 3RD FLOOR,ASHIANA TRADE CENTER,ADITYAPUR,JAMSHEDPUR	ss_alloys@yahoo.co.in	0657 6577148
		18846	COSMOS ELECTRODES PVT., LTD,	9/2,KIBE COMPOUND,CHHOTI GEALTOLI CHOURAHA,INDORE		0731 2707946
		18705	MODI HITECH INDIA LTD.,	1400,MODI TOWER98,NEHRU PLACE,NEW DELHI	gmmelectrode@gmail.com	011 4250 4577
		10758	ALPHA ARC INDUSTRIES,	B-5,SECTOR A5/6 TRONICA CITYLONIGHAZIABAD, UP	alphaarc@yahoo.com	0 99114 41441
		18300	SUPERON SCHWEISSTECHNIK INDIA LTD.,	191-D,SECTOR-IV,PHASE-II,IMT MANESAR,GURGAON,HARYANA		011-24647199
		15089	WELDCRAFT PRIVATE LIMITED,	72, INDUSTRIAL SUBURB,2ND STAGE, TUMKUR ROAD,BANGALORE.	weldcraft@vsnl.net	080 3373351
		18597	SHIELDARC EQUIPMENTS PVT. LTD,	85,ELLIOT ROAD,KOLKATA		
		18540	KOLLIPARA ELECTRODES PVT.LTD.,	KRISHNA NAGAR,PENAMALURUKRISHNA DIST.(AP)		
		14575	WELD ALLOY PRODUCTS,	C - 33, SECTOR - IV, NOIDANOIDA DIST.GAUTAM BUDH NAGAR (UP)	wap2005@airtelmail.in	0120-2557183
		14429	ALPHA FLUX & ELETRODES,	178/2-A2,THURAIYUR ROAD,PULIVALAM, MUSIRI - T.K.TRICHY DISTRICT	t.vasanthan@sify.com	04327 294169
		13211	D&H INDIA LIMITED	PLOT 'A', SECTOR 'A'INDUSTRIAL AREA,SANWER ROADINDORE	dhindia@sancharnet.in	0731-4273501-...
		14040	MANTEK ELECTRODS PRIVATE LTD,	D-74A, DEVELOPED PLOT ESTATE,THUVAKUDITRICHY		2501540
		13906	MARUTI WELD LIMITED,	I-1, KIRTI NAGARNEW DELHI	marutiweld@marutiweld.com	25913411
		13763	CLASSIC ELECTRODES (INDIA) LTD.,	1, BONFIELD LANE2 ND FLOORKOLKATA	classicelectrodes@yahoo.co.in	033 22429581
		15088	NIVETHA ELECTRODES,	195,PUDUKKOTTAI ROAD,TAMILNADU TANNREY'S BUILDING,SEMPATTU,TIRUCHIRAPALLY		0431 2341377
		10774	D&H SECHERON ELECTRODES PVT LTD.	P.B.NO.344-46,INDL.ESTATE,KILAMAIDANINDORE	sales@dnhsecheron.net	0731-4229222
		13549	ATHARVE WELDING TECHNOLOGIES (INDIA	PVT.LTD.,A 192,M.I.D.C.CHINCHOLI,SOLAPUR	atharv.wt@hotmail.com	0217-273 7029

**SECTION - VIII
LIST OF APPROVED VENDORS**

1) WELDING CONSUMABLES SUPPLIERS LIST

Mat Group	Material Group Description	Vendor No	Vendor Name	Vendor Address	EMAIL	PHONE1
		13487	MAGNARC ELECTRODES PVT.LTD.,	PENDUTHIVISAGAPATNAM	magnarc@hotmail.com	0891-276 4381...
		14523	JINDAL DUROWELD	BN / 19 & 20,KALUNGA INDL. ESTATE,ROURKELA.	jdplrkl@yahoo.co.in	0661 266 0621
		15082	ROYAL WELDING WIRES PVT. LTD.,	7,KARANAI PUDUCHERRY VILLAGE,VIA.URAPAKKAM,KANCHIPURAM DIST,	royal@royalwires.co.in	044-3741 1610
		15090	RAJ KESARI ELECTRODES,	35,RAVINDRA NAGAR,(PRATAP NAGAR)UDAIPUR	rajkesari@yahoo.com	0294 2490193
		14584	SUN ELECTRODE	SF No.119/3, RAYAMUNDANPATTI,PUDHUKUDI ROAD,TANJORE.	sunenterprises2011@gmail.com	0 88256 36464
		14534	AARYA ELECTRODES PVT.LTD.	JOHN'S MILL NO.3,JEONI MANDI,AGRA.	vibhor@aaryaelectrodes.com	0562 262 2121
		18433	NUCOR WELD(INDIA)PVT.LTD.,	NO.223,KONAPPANA AGRAHARA,ELECTRONIC CITY POST,BANGALORE	nucorweldinida@yahoo.com	080-2852 2057
		18846	COSMOS ELECTRODES PVT., LTD,	9/2,KIBE COMPOUND,CHHOTI GEALTOLI CHOURAHA,INDORE		0731 2707946
		13487	MAGNARC ELECTRODES PVT.LTD.,	PENDUTHIVISAGAPATNAM	magnarc@hotmail.com	0891-276 4381...
		11380	MALU ELECTRODES PVT.LIMITED	111, RAMAKRISHNA APPARTMENT,CHHAPRU NAGAR SQUARE,CENTRAL AVENUE NAGAR,NAGPUR	meploffice@rediffmail.com	0712 - 2734895
		11227	HONAVAR ELECTRODES PVT. LTD.,	305-309,3RD FLOOR,DAMJI SHAMJI INDUSTRIAL COMPLEX ,9,L.B.S MARG, KURLA(WEST)MUMBAI	hel@vsnl.com	022-25020317
		15102	SOLARC WELD RODS,	OLD NO.12,NEW NO.14,65th STREET12th AVENUE,ASHOK NAGAR,CHENNAI	soarcweldrods@gmail.com	044-24891173
		15086	SRI RENGHA ELECTRODES (P) LTD,	137/3, GANAPATHY NAGAR,ARIYAMANGALAMTRICHY		0431-25501173
		18432	VIJEY ELECTRODES AND WIRES PVT.	83/1,THIRUNEERMALAI ROAD,NAGELKENI, CHROMPET,CHENNAI	vjelect@yahoo.co.in	044-2238 1098
		19305	MURLI ELECTRODE PVT. LTD,	EL. 30,M.I.D.C.INDUSTRIAL ESTATE,HINGNA ROAD,NAGPUR	sudhir_0408@rediffmail.com	0712 2769347
		18540	KOLLIPARA ELECTRODES PVT.LTD.,	KRISHNA NAGAR,PENAMALURUKRISHNA DIST.(AP)		
		18705	MODI HITECH INDIA LTD.,	1400,MODI TOWER98,NEHRU PLACE,NEW DELHI	gmmelectrode@gmail.com	011 4250 4577
		15085	VOLTARC ELECTRODES (P) LTD,	10-77, FIRST MAIN,ROYAL NAGAR,H.O.SURYAJYOTHI,R.C.ROAD, P.B.NO.33,TIRUPATHI	voltarc@rediffmail.com	0877 2241462

**SECTION - VIII
LIST OF APPROVED VENDORS**

1) WELDING CONSUMABLES SUPPLIERS LIST

Mat Group	Material Group Description	Vendor No	Vendor Name	Vendor Address	EMAIL	PHONE1
WCC05	WELDG.ELECTRODES:SMA	15091	MAGNA ENGINEERING	CHINNAVUTAPALLIGANAVARAM MANDAL,VIJAYAWADA		08676 252181
		11378	MAILAM INDIA LIMITED	MAILAM MAIN ROAD,SEDARAPET,PONDICHERRY	mailam@mailanindia.com	0413-2677311
		17643	SUNDEEP ELECTRODES PVT. LTD.,	BULANSHAHAR ROAD,HAPUR		
		13763	CLASSIC ELECTRODES (INDIA) LTD.,	1, BONFIELD LANE2 ND FLOORKOLKATA	classicelectrodes@yahoo.co.in	033 22429581
		16548	WELD EXCEL INDIA LTD.,	D-230,PHASE VII,FOCAL POINT,LUDHIANA		
		10758	ALPHA ARC INDUSTRIES,	B-5,SECTOR A5/6 TRONICA CITYLONIGHAZIABAD, UP	alphaarc@yahoo.com	0 99114 41441
		12893	RUKHMANI ELECTRODES PVT.LTD.,	31,THAKURPUKUR (N.W) ROAD,P.O.BADU,DIST:24 PARGANAS(N)KOLKATA	rukhmanielectrodes@rediffmail.com	033-2526 2039
		18300	SUPERON SCHWEISSTECHNIK INDIA LTD.,	191-D,SECTOR-IV,PHASE-II,IMT MANESAR,GURGAON,HARYANA		011-24647199
		10785	ADOR WELDING LIMITED	CORPORATE MARKETING OFFICE,P.B. NO. 2, CHINCHWAD,PUNE	acegasindia@gamil.com	
		14575	WELD ALLOY PRODUCTS,	C - 33, SECTOR - IV, NOIDANOIDA DIST.GAUTAM BUDH NAGAR (UP)	wap2005@airtelmail.in	0120-2557183
		15083	MARUTHI ELECTRODES (P) LTD.,	138,5TH FLOOR,MARUTHI TOWERAIRPORT ROAD,KODIHALU,BANGALORE	meplelec@bgl.vsnl.net.in	080 25275848
		15089	WELDCRAFT PRIVATE LIMITED,	72, INDUSTRIAL SUBURB,2ND STAGE, TUMKUR ROAD,BANGALORE.	weldcraft@vsnl.net	080 3373351
		13906	MARUTI WELD LIMITED,	I-1, KIRTI NAGARNEW DELHI	marutiweld@marutiweld.com	25913411
		15082	ROYAL WELDING WIRES PVT. LTD.,	7,KARANAI PUDUCHERRY VILLAGE,VIA.URAPAKKAM,KANCHIPURAM DIST,	royal@royalwires.co.in	044-3741 1610
		13211	D&H INDIA LIMITED	PLOT 'A', SECTOR 'A'INDUSTRIAL AREA,SANWER ROADINDORE	dhindia@sancharnet.in	0731-4273501-...
		13911	ROYAL ARC ELECTRODES PVT. LTD	ROYAL HOUSE, PLOT NO.26,VILLAGE VALIV,VASAI (EAST) THANE	royalarc@vsnl.com	0250 2480520
		17813	K.M.CROWN WELDING CONSUMABLES PVT.,	BLOCK NO.16A,16B & 17A,INDUSTRIAL AREA NO.1,A.B.ROAD,DEWAS	kmcrownwelding@dataone.com	07272 259384578
		13388	THE INDIAN SEEL & WIRE PRODUCTS LTD	PO INDIRA NAGAR,JAMSHEDPUR - 831 008JHARKAND	upshar@tatasteel.com	0657- 6512744
		14791	ANAND ARC LTD.,	NO.22(OLD.31),RAILWAY COLONY,III STREET,AMINJIKARAI,CHENNAI		044 23746379
		10667	EUREKA SYSTEMS AND ELECTRODES P.LTD	11/15A,SELVARAJAPURAM,CHINTHAMANIPUDUR, COIMBATORE	info@eurekaelectrodes@gmail.com	0422-268 7199...

**SECTION - VIII
LIST OF APPROVED VENDORS**

1) WELDING CONSUMABLES SUPPLIERS LIST

Mat Group	Material Group Description	Vendor No	Vendor Name	Vendor Address	EMAIL	PHONE1
		15087	V.N.C.ELECTRODEES,	3, INDUSTRIAL ESTATE,S.VELLALAPATTIKARUR	kru_vnc@sancharnet.in	04324 242774
		11881	FUSION ENGG. PRODUCTS LTD.,	B-16,Vith PHASE, POST.GAMARIA(JAMSHEDPUR)SERAIKELA- KHARSAWAN,GAMARIA	info@fusionweld.co.in	0657-6542444
		15084	DWEKAM ELECTRODES LTD,	TALAWALI CHANDA,A.B.ROAD, P.O.MANGILAINDORE (MP)	vk.khandelwal@dwekam.org	0731 422 9500...
		17814	CALCUTTA ELECTRODES PVT. LTD.,	SARDAR PATEL TIMBER MARKET,BHANPURI,RAIPUR	calcutta_electrodes2006@yahoo.com	0771 4090615
		17644	VARUN ELECTRODES PVT. LTD.,	H-56,INDUSTRIAL AREA,PANIPAT	kapoor@varunelectrodes.com	0180 2653085
		14040	MANTEK ELECTRODS PRIVATE LTD,	D-74A, DEVELOPED PLOT ESTATE,THUVAKUDITRICHY		2501540
		15833	THIRUMALA ELECTRODES CO.,	S1-17B,'S' TYPE,SIDCO INDUSTRIAL ESTATE,THUVAKUDI,TRICHY	tec_sevenarcs@yahoo.co.in	0431-6573566
		17451	WELDWELL ELECTRODES,	D-59 M.I.D.C.,HINGNA INDUSTRIAL AREA,NAGPUR	weldwellngp@gmail.com	07104 232211/...
		13693	RASI ELECTRODES LTD.,	21, RAJA ANNAMALAI ROAD,FLAT NO A / 14, THIRD FLOOR,CHENNAI	rele@airtellmail.in	044 26424523
		11420	MODI ARC ELECTRODES CO.	MODINAGARUTTAR PRADESHGHAZIABAD	modiarc@ndb.vsnl.net.in	01232 - 242427
		19111	SPECTRA SUPER ALLOYS LTD,	324 / 325, 3RD FLOOR,ASHIANA TRADE CENTER,ADITYAPUR,JAMSHEDPUR	ss_alloys@yahoo.co.in	0657 6577148
		15090	RAJ KESARI ELECTRODES,	35,RAVINDRA NAGAR,(PRATAP NAGAR)UDAIPUR	rajkesari@yahoo.com	0294 2490193
		11528	RAAJRATNA ELECTRODES LTD	11, SONAROOPA, OPP.LALBANGLOWC.G.ROAD, NAVARANGPURA AHMEDABAD	mktg@gnahd-rel.global.net.in	079 - 6445258
		10081	ESAB INDIA LTD	KARUMUTTU CENTRE, 6TH FLOORNEW NO.634(OLD NO.498)ANNA SALAI, NANDANAM,CHENNAI-35CHENNAI	jagdeesh.ds@esab.co.in	044-826 9343
		19906	BAGHERWAL ELECTRODES PVT.LTD.,	20-23,VAIBHAV CHAMBER,7/1,USHAGANJ CHHAWANI,INDORE	bagherwal13@yahoo.com	0731-2905067
		10774	D&H SECHERON ELECTRODES PVT LTD.	P.B.NO.344-46,INDL.ESTATE,KILAMAIDANINDORE	sales@dnhsecheron.net	0731-4229222
		13690	GEE LIMITED,	PLOT E-1, ROAD NO. 7,WAGLE INDUSTRIAL ESTATETHANE		
		18432	VIJEY ELECTRODES AND WIRES PVT.	83/1,THIRUNEERMALAI ROAD,NAGELKENI, CHROMPET,CHENNAI	vjelect@yahoo.co.in	044-2238 1098
		11378	MAILAM INDIA LIMITED	MAILAM MAIN ROAD,SEDARAPET,PONDICHERRY	mailam@mailanindia.com	0413-2677311

**SECTION - VIII
LIST OF APPROVED VENDORS**

1) WELDING CONSUMABLES SUPPLIERS LIST

Mat Group	Material Group Description	Vendor No	Vendor Name	Vendor Address	EMAIL	PHONE1
WCC06	WELDG.ELECTRODES:SMA	10774	D&H SECHERON ELECTRODES PVT LTD.	P.B.NO.344-46,INDL.ESTATE,KILAMAIDANINDORE	sales@dnhsecheron.net	0731-4229222
		11227	HONAVAR ELECTRODES PVT. LTD.,	305-309,3RD FLOOR,DAMJI SHAMJI INDUSTRIAL COMPLEX ,9,L.B.S MARG, KURLA(WEST)MUMBAI	hel@vsnl.com	022-25020317
		13690	GEE LIMITED,	PLOT E-1, ROAD NO. 7,WAGLE INDUSTRIAL ESTATETHANE		
WCC09	Welding Consumable	20130	ALCONIX CORPORATION	SANNO PARK TOWER,12TH FLOOR,2-11-1 NAGATA-CHO,CHIYODA-KU,TOKYO ,JAPAN	Inamori.khei@alconix.com	
WCF01	WELDG.WIRE:FLUX CORE	21065	HYUNDAI WELDING CO. LTD.,	15F, 137-37 GANGNAM KU,INSONG BUILDING,SAMSUNG DONG,SEOUL	alex@hdweld.co.kr	82-02 6230-6077
		20970	THE SHANGHAI LINCOLN ELECTRIC	LANE 5008,HU TAI ROAD,BOASHAN, SHANGAI-201907		86 21 560 26664
		20047	KANEMATSU TRADING CORPORATION	6th FLOOR,AKEBONO NIHONBASHI BLDG,19 - 5,NIHONBASHIKOAMI-CHO,CHUO - KU, TOKYO, 103 - 0016.	nikko-bocki@kgt.kanematsu.co.jp	81 3 5283 3680
		91270	VEEPEES INDIA,	C-52, 4TH AVENUE ROAD,GUINDY INDUSTRIAL ESTATE,GUINDY.CHENNAI	veepeesindia@gmail.com	044-43534354
		14676	ITW INDIA LIMITED: WELDING GROUP.	CORPORATE HOUSE,NO.1, SUN CHAMBERS,NEAR SOLA BRIDGE, S.G. HIGHWAY,AHMEDABAD.	fredric.prabhu@itwindia.com	079 3315 4009
WCF02	WELDG.WIRE:FLUX CORE	20047	KANEMATSU TRADING CORPORATION	6th FLOOR,AKEBONO NIHONBASHI BLDG,19 - 5,NIHONBASHIKOAMI-CHO,CHUO - KU, TOKYO, 103 - 0016.	nikko-bocki@kgt.kanematsu.co.jp	81 3 5283 3680
		20563	BOHLER SCHWEISSTECHNNIK	UNIONSTRASSE-1,D-59067 HAMM,DEUTSCHLAND GmbH.,GERMANY		
WCF03	WG:WIRE.FC.E309LMoTO	20563	BOHLER SCHWEISSTECHNNIK	UNIONSTRASSE-1,D-59067 HAMM,DEUTSCHLAND GmbH.,GERMANY		
		20047	KANEMATSU TRADING CORPORATION	6th FLOOR,AKEBONO NIHONBASHI BLDG,19 - 5,NIHONBASHIKOAMI-CHO,CHUO - KU, TOKYO, 103 - 0016.	nikko-bocki@kgt.kanematsu.co.jp	81 3 5283 3680
		20033	KISWEL LTD.,	HEUNGKOOK B/D, 43-1,JUJA-DONGCHUNG-GU, C.P.O.BOX 8641SEOUL, KOREA.SEOUL,KOREA.	export@kiswel.com	82-2-2270-9400
WCF04	WELDG: WIRE: FLUX CO	91270	VEEPEES INDIA,	C-52, 4TH AVENUE ROAD,GUINDY INDUSTRIAL ESTATE,GUINDY.CHENNAI	veepeesindia@gmail.com	044-43534354
		21065	HYUNDAI WELDING CO. LTD.,	15F, 137-37 GANGNAM KU,INSONG BUILDING,SAMSUNG DONG,SEOUL	alex@hdweld.co.kr	82-02 6230-6077

**SECTION - VIII
LIST OF APPROVED VENDORS**

1) WELDING CONSUMABLES SUPPLIERS LIST

Mat Group	Material Group Description	Vendor No	Vendor Name	Vendor Address	EMAIL	PHONE1
		20047	KANEMATSU TRADING CORPORATION	6th FLOOR,AKEBONO NIHONBASHI BLDG,19 - 5,NIHONBASHIKOAMI-CHO,CHUO - KU, TOKYO, 103 - 0016.	nikko-bocki@kgt.kanematsu.co.jp	81 3 5283 3680
WCF05	WELDG: WIRE: FLUX CO	91270	VEEPEES INDIA,	C-52, 4TH AVENUE ROAD,GUINDY INDUSTRIAL ESTATE,GUINDY.CHENNAI	veepeesindia@gmail.com	044-43534354
		20047	KANEMATSU TRADING CORPORATION	6th FLOOR,AKEBONO NIHONBASHI BLDG,19 - 5,NIHONBASHIKOAMI-CHO,CHUO - KU, TOKYO, 103 - 0016.	nikko-bocki@kgt.kanematsu.co.jp	81 3 5283 3680
WCF06	WELDG. WIRE: FLUX CO	91270	VEEPEES INDIA,	C-52, 4TH AVENUE ROAD,GUINDY INDUSTRIAL ESTATE,GUINDY.CHENNAI	veepeesindia@gmail.com	044-43534354
		20047	KANEMATSU TRADING CORPORATION	6th FLOOR,AKEBONO NIHONBASHI BLDG,19 - 5,NIHONBASHIKOAMI-CHO,CHUO - KU, TOKYO, 103 - 0016.	nikko-bocki@kgt.kanematsu.co.jp	81 3 5283 3680
		20011	BOHLER SCHWEISSTECHNIK AUSTRIA	WERK DEUCHENDORF,A 8605, KAPPENBERG, POSTFACH - 9,AUSTRIA.AUSTRIA.		0043/3862301
		20067	UTP SCHWEISS MATERIAL GMBH & CO	ELSASSER STR 10D-79189, BAD KROZINGENGERMANY.		49(0) 07633 / 40
WCF09	E71T-1 MARATHON PACK	20047	KANEMATSU TRADING CORPORATION	6th FLOOR,AKEBONO NIHONBASHI BLDG,19 - 5,NIHONBASHIKOAMI-CHO,CHUO - KU, TOKYO, 103 - 0016.	nikko-bocki@kgt.kanematsu.co.jp	81 3 5283 3680
		91270	VEEPEES INDIA,	C-52, 4TH AVENUE ROAD,GUINDY INDUSTRIAL ESTATE,GUINDY.CHENNAI	veepeesindia@gmail.com	044-43534354
		20970	THE SHANGHAI LINCOLN ELECTRIC	LANE 5008,HU TAI ROAD,BOASHAN, SHANGAI-201907		86 21 560 26664
		14676	ITW INDIA LIMITED: WELDING GROUP.	CORPORATE HOUSE,NO.1, SUN CHAMBERS,NEAR SOLA BRIDGE, S.G. HIGHWAY,AHMEDABAD.	fredric.prabhu@itwindia.com	079 3315 4009
		10081	ESAB INDIA LTD	KARUMUTTU CENTRE, 6TH FLOORNEW NO.634(OLD NO.498)ANNA SALAI, NANDANAM,CHENNAI-35CHENNAI	jagdeesh.ds@esab.co.in	044-826 9343
		21065	HYUNDAI WELDING CO. LTD.,	15F, 137-37 GANGNAM KU,INSONG BUILDING,SAMSUNG DONG,SEOUL	alex@hdweld.co.kr	82-02 6230-6077
WCF11	ER70S - 6 BULK PACKS	20970	THE SHANGHAI LINCOLN ELECTRIC	LANE 5008,HU TAI ROAD,BOASHAN, SHANGAI-201907		86 21 560 26664
		14676	ITW INDIA LIMITED: WELDING GROUP.	CORPORATE HOUSE,NO.1, SUN CHAMBERS,NEAR SOLA BRIDGE, S.G. HIGHWAY,AHMEDABAD.	fredric.prabhu@itwindia.com	079 3315 4009

**SECTION - VIII
LIST OF APPROVED VENDORS**

1) WELDING CONSUMABLES SUPPLIERS LIST

Mat Group	Material Group Description	Vendor No	Vendor Name	Vendor Address	EMAIL	PHONE1
		10081	ESAB INDIA LTD	KARUMUTTU CENTRE, 6TH FLOORNEW NO.634(OLD NO.498)ANNA SALAI, NANDANAM,CHENNAI-35CHENNAI	jagdeesh.ds@esab.co.in	044-826 9343
WCFA1	BULKPACK :E551T1-B2C	14676	ITW INDIA LIMITED: WELDING GROUP.	CORPORATE HOUSE,NO.1, SUN CHAMBERS,NEAR SOLA BRIDGE, S.G. HIGHWAY,AHMEDABAD.	fredric.prabhu@itwindia.com	079 3315 4009
		91270	VEEPEES INDIA,	C-52, 4TH AVENUE ROAD,GUINDY INDUSTRIAL ESTATE,GUINDY.CHENNAI	veepeesindia@gmail.com	044-43534354
WCH03	WELD:SMAW:HF-ECrA	20130	ALCONIX CORPORATION	SANNO PARK TOWER,12TH FLOOR,2-11-1 NAGATA-CHO,CHIYODA-KU,TOKYO ,JAPAN	Inamori.khei@alconix.com	
		20018	KENNAMETAL STELLITE	L.P. 1201 Eisenhower Drive N.Goshen ,IN 46526 USAUSA	asiasales@stellitesales.com	44-0-1793 498...
WCH05	SMAW ELECTRO ECoCr-E	20073	WEARTECH INTL INC	13032, PARK STREETSANTA FE SPRINGS , CA 90670USAUSA		001-562 945 7847
WCL07	WELDG.ELECTRODES:SMA	10774	D&H SECHERON ELECTRODES PVT LTD.	P.B.NO.344-46,INDL.ESTATE,KILAMAIDANINDORE	sales@dnhsecheron.net	0731-4229222
		20067	UTP SCHWEISS MATERIAL GMBH & CO	ELSASSER STR 10D-79189, BAD KROZINGENGERMANY.		49(0) 07633 / 40
		21991	SPECIAL METALS WELDING PRODUCTS	1401,BURRIS ROAD,NEWTON,NORTH COROLINA 28658	rphillips@smwpc.com	828-465-0352
		20563	BOHLER SCHWEISSTECHNIK	UNIONSTRASSE-1,D-59067 HAMM,DEUTSCHLAND GmbH.,GERMANY		
WCL08	SMAW ELECTRODE	21411	METRODE PRODUCTS LIMITED,	HANWORTH LANE,CHERTESY,SURREY KT169LL,		
		21991	SPECIAL METALS WELDING PRODUCTS	1401,BURRIS ROAD,NEWTON,NORTH COROLINA 28658	rphillips@smwpc.com	828-465-0352
		22391	AIR-LIQUIDE WELDING FRANCE,	13,RUE D'EPLUCHES-BP70024 SAINT-OUEN I'AUMONE,95315 CERGY PONTOISE CEDEX	jean-paul.shmitt@airliquide.com	1342 13480
WCS20	WELDG.ELECTRODES:SMA	10774	D&H SECHERON ELECTRODES PVT LTD.	P.B.NO.344-46,INDL.ESTATE,KILAMAIDANINDORE	sales@dnhsecheron.net	0731-4229222
		10081	ESAB INDIA LTD	KARUMUTTU CENTRE, 6TH FLOORNEW NO.634(OLD NO.498)ANNA SALAI, NANDANAM,CHENNAI-35CHENNAI	jagdeesh.ds@esab.co.in	044-826 9343
		11420	MODI ARC ELECTRODES CO.	MODINAGARUTTAR PRADESHGHAZIABAD	modiarc@ndb.vsnl.net.in	01232 - 242427
		11378	MAILAM INDIA LIMITED	MAILAM MAIN ROAD,SEDARAPET,PONDICHERRY	mailam@mailanindia.com	0413-2677311
WCS22	WELDG.ELECTRODES:SMA	10081	ESAB INDIA LTD	KARUMUTTU CENTRE, 6TH FLOORNEW NO.634(OLD NO.498)ANNA SALAI, NANDANAM,CHENNAI-35CHENNAI	jagdeesh.ds@esab.co.in	044-826 9343

**SECTION - VIII
LIST OF APPROVED VENDORS**

1) WELDING CONSUMABLES SUPPLIERS LIST

Mat Group	Material Group Description	Vendor No	Vendor Name	Vendor Address	EMAIL	PHONE1
		10774	D&H SECHERON ELECTRODES PVT LTD.	P.B.NO.344-46,INDL.ESTATE,KILAMAIDANINDORE	sales@dnhsecheron.net	0731-4229222
WCS27	WELDG.ELECTRODES:SMA	10081	ESAB INDIA LTD	KARUMUTTU CENTRE, 6TH FLOORNEW NO.634(OLD NO.498)ANNA SALAI, NANDANAM,CHENNAI-35CHENNAI	jagdeesh.ds@esab.co.in	044-826 9343
		10774	D&H SECHERON ELECTRODES PVT LTD.	P.B.NO.344-46,INDL.ESTATE,KILAMAIDANINDORE	sales@dnhsecheron.net	0731-4229222
WCS28	WELDG.ELECTRODES:SMA	10036	BHARAT HEAVY ELECTRICALS LTD	WELDING CONSUMABLE MFG CENTRETIRUCHIRAPALLITIRUCHIRAPALLI		
		10774	D&H SECHERON ELECTRODES PVT LTD.	P.B.NO.344-46,INDL.ESTATE,KILAMAIDANINDORE	sales@dnhsecheron.net	0731-4229222
		10081	ESAB INDIA LTD	KARUMUTTU CENTRE, 6TH FLOORNEW NO.634(OLD NO.498)ANNA SALAI, NANDANAM,CHENNAI-35CHENNAI	jagdeesh.ds@esab.co.in	044-826 9343
WCS29	WELDG.ELECTRODES:SMA	10081	ESAB INDIA LTD	KARUMUTTU CENTRE, 6TH FLOORNEW NO.634(OLD NO.498)ANNA SALAI, NANDANAM,CHENNAI-35CHENNAI	jagdeesh.ds@esab.co.in	044-826 9343
		10774	D&H SECHERON ELECTRODES PVT LTD.	P.B.NO.344-46,INDL.ESTATE,KILAMAIDANINDORE	sales@dnhsecheron.net	0731-4229222
		10036	BHARAT HEAVY ELECTRICALS LTD	WELDING CONSUMABLE MFG CENTRETIRUCHIRAPALLITIRUCHIRAPALLI		
WCS30	WELDG.ELECTRODES:SMA	11378	MAILAM INDIA LIMITED	MAILAM MAIN ROAD,SEDARAPET,PONDICHERRY	mailam@mailanindia.com	0413-2677311
		10774	D&H SECHERON ELECTRODES PVT LTD.	P.B.NO.344-46,INDL.ESTATE,KILAMAIDANINDORE	sales@dnhsecheron.net	0731-4229222
		10081	ESAB INDIA LTD	KARUMUTTU CENTRE, 6TH FLOORNEW NO.634(OLD NO.498)ANNA SALAI, NANDANAM,CHENNAI-35CHENNAI	jagdeesh.ds@esab.co.in	044-826 9343
		11420	MODI ARC ELECTRODES CO.	MODINAGARUTTAR PRADESHGHAZIABAD	modiarc@ndb.vsnl.net.in	01232 - 242427
WCS31	WELD:SMAW:SS E410-15	10774	D&H SECHERON ELECTRODES PVT LTD.	P.B.NO.344-46,INDL.ESTATE,KILAMAIDANINDORE	sales@dnhsecheron.net	0731-4229222
		10036	BHARAT HEAVY ELECTRICALS LTD	WELDING CONSUMABLE MFG CENTRETIRUCHIRAPALLITIRUCHIRAPALLI		
		11378	MAILAM INDIA LIMITED	MAILAM MAIN ROAD,SEDARAPET,PONDICHERRY	mailam@mailanindia.com	0413-2677311
WCS32	WELD:SMAW:SS E430-15	10774	D&H SECHERON ELECTRODES PVT LTD.	P.B.NO.344-46,INDL.ESTATE,KILAMAIDANINDORE	sales@dnhsecheron.net	0731-4229222
		11378	MAILAM INDIA LIMITED	MAILAM MAIN ROAD,SEDARAPET,PONDICHERRY	mailam@mailanindia.com	0413-2677311

**SECTION - VIII
LIST OF APPROVED VENDORS**

1) WELDING CONSUMABLES SUPPLIERS LIST

Mat Group	Material Group Description	Vendor No	Vendor Name	Vendor Address	EMAIL	PHONE1
		10036	BHARAT HEAVY ELECTRICALS LTD	WELDING CONSUMABLE MFG CENTRETIRUCHIRAPALLITIRUCHIRAPALLI		
WCS38	SMAW ELECTRD 253MA	22515	BOHLER WELDING GROUP NORDIC SALES A	BOX 501, SE - 774 27 AVESTA,SWEDEN.	INFO@BWGNORDIC.COM	46022685750
		22516	AB SANDVIK PROCESS SYSTEM,	SE 811 81 SANDVIKENSWEDEEN.	donald.anderson@sandvik.com	4602626 5600
WCS39	SMAW ELEC E308H-16	10081	ESAB INDIA LTD	KARUMUTTU CENTRE, 6TH FLOORNEW NO.634(OLD NO.498)ANNA SALAI, NANDANAM,CHENNAI-35CHENNAI	jagdeesh.ds@esab.co.in	044-826 9343
		10774	D&H SECHERON ELECTRODES PVT LTD.	P.B.NO.344-46,INDL.ESTATE,KILAMAIDANINDORE	sales@dnhsecheron.net	0731-4229222
WCS40	SMAW ELEC E316H-16	10081	ESAB INDIA LTD	KARUMUTTU CENTRE, 6TH FLOORNEW NO.634(OLD NO.498)ANNA SALAI, NANDANAM,CHENNAI-35CHENNAI	jagdeesh.ds@esab.co.in	044-826 9343
		10774	D&H SECHERON ELECTRODES PVT LTD.	P.B.NO.344-46,INDL.ESTATE,KILAMAIDANINDORE	sales@dnhsecheron.net	0731-4229222
WCT01	WELD:HF-HAY.ALLY 25	20130	ALCONIX CORPORATION	SANNO PARK TOWER,12TH FLOOR,2-11-1 NAGATA- CHO,CHIYODA-KU,TOKYO ,JAPAN	Inamori.khei@alconix.com	
		10313	ZIRCAST LTD	UNIT -2, NO.37,JIGANI INDUSTRIAL AREABANGALORE - 562 106BANGALORE	jsuresh@zircast.com	08110 /26238
WCT02	WELD:HF-HAY.ALLY 21	20073	WEARTECH INTL INC	13032, PARK STREETSANTA FE SPRINGS , CA 90670USAUSA		001-562 945 7847
		20130	ALCONIX CORPORATION	SANNO PARK TOWER,12TH FLOOR,2-11-1 NAGATA- CHO,CHIYODA-KU,TOKYO ,JAPAN	Inamori.khei@alconix.com	
WCT03	WELD:HF-RCO CRA	20018	KENNAMETAL STELLITE	L.P. 1201 Eisenhower Drive N.Goshen ,IN 46526 USAUSA	asiasales@stellitesales.com	44-0-1793 498...
		20073	WEARTECH INTL INC	13032, PARK STREETSANTA FE SPRINGS , CA 90670USAUSA		001-562 945 7847
		20130	ALCONIX CORPORATION	SANNO PARK TOWER,12TH FLOOR,2-11-1 NAGATA- CHO,CHIYODA-KU,TOKYO ,JAPAN	Inamori.khei@alconix.com	
		10313	ZIRCAST LTD	UNIT -2, NO.37,JIGANI INDUSTRIAL AREABANGALORE - 562 106BANGALORE	jsuresh@zircast.com	08110 /26238
WCT04	WG:PWD:HF:TYP COCRA	20011	BOHLER SCHWEISSTECHNIK AUSTRIA	WERK DEUCHENDORF,A 8605, KAPPENBERG, POSTFACH - 9,AUSTRIA.AUSTRIA.		0043/3862301
		20073	WEARTECH INTL INC	13032, PARK STREETSANTA FE SPRINGS , CA 90670USAUSA		001-562 945 7847
		20018	KENNAMETAL STELLITE	L.P. 1201 Eisenhower Drive N.Goshen ,IN 46526 USAUSA	asiasales@stellitesales.com	44-0-1793 498...
		20067	UTP SCHWEISS MATERIAL GMBH & CO	ELSASSER STR 10D-79189, BAD KROZINGENGERMANY.		49(0) 07633 / 40

**SECTION - VIII
LIST OF APPROVED VENDORS**

1) WELDING CONSUMABLES SUPPLIERS LIST

Mat Group	Material Group Description	Vendor No	Vendor Name	Vendor Address	EMAIL	PHONE1
		20130	ALCONIX CORPORATION	SANNO PARK TOWER,12TH FLOOR,2-11-1 NAGATA-CHO,CHIYODA-KU,TOKYO ,JAPAN	Inamori.khei@alconix.com	
		20321	HOGANAS BELGIUM SA	COLDSTREAM DIVISIONRUELLE GROS PIERRE 10B-7800 ATHRUELLE GROS PIERRE 10B-7800 ATH		
WCW01	EL-8 SAW WIRE	14791	ANAND ARC LTD.,	NO.22(OLD.31),RAILWAY COLONY,III STREET,AMINJIKARAI,CHENNAI		044 23746379
		15085	VOLTARC ELECTRODES (P) LTD,	10-77, FIRST MAIN,ROYAL NAGAR,H.O.SURYAJYOTHI,R.C.ROAD, P.B.NO.33,TIRUPATHI	voltarc@rediffmail.com	0877 2241462
		15084	DWEKAM ELECTRODES LTD,	TALAWALI CHANDA,A.B.ROAD, P.O.MANGILAINDORE (MP)	vk.khandelwal@dwekam.org	0731 422 9500...
		13693	RASI ELECTRODES LTD.,	21, RAJA ANNAMALAI ROAD,FLAT NO A / 14, THIRD FLOOR,CHENNAI	rele@airtelmail.in	044 26424523
		19905	T.M.INDUSTRIES,	PLOT NO.26-27,PHASE-I,SILTARA GROWTH CENTRE,SILTARA RAIPUR	tmtapadia@rediffmail.com	0771-2100524
		10774	D&H SECHERON ELECTRODES PVT LTD.	P.B.NO.344-46,INDL.ESTATE,KILAMAIDANINDORE	sales@dnhsecheron.net	0731-4229222
		19114	WELMET TECHNOLOGIES PVT. LTD.,	34,P.N.MAIDU INDUSTRIAL ESTATE,M.I.D.C. HINGNA,NAGPUR		
		11528	RAAJRATNA ELECTRODES LTD	11, SONAROOPA, OPP.LALBANGLOWC.G.ROAD, NAVARANGPURA AHMEDABAD	mktg@gnaht-rel.global.net.in	079 - 6445258
		13534	RUPA INDUSTRIES,	2-2-105 to 180/10,GANESH CHAMBERSRANIGUNJ,SECUNDERABAD	rupaent@vsnl.net	040-2771 3714
		13211	D&H INDIA LIMITED	PLOT 'A', SECTOR 'A'INDUSTRIAL AREA,SANWER ROADINDORE	dhindia@sancharnet.in	0731-4273501-...
		11378	MAILAM INDIA LIMITED	MAILAM MAIN ROAD,SEDARAPET,PONDICHERRY	mailam@mailanindia.com	0413-2677311
		17813	K.M.CROWN WELDING CONSUMABLES PVT.,	BLOCK NO.16A,16B & 17A,INDUSTRIAL AREA NO.1,A.B.ROAD,DEWAS	kmcrownwelding@dataone.com	07272 259384578
		16166	EVERSHINE WIRES	178/2-A3, THURAIYUR ROAD,PULIVALAM,MUSIRI TALUK,TRICHY	evershinewires@rediffmail.com	04327 235527
		10785	ADOR WELDING LIMITED	CORPORATE MARKETING OFFICE,P.B. NO. 2, CHINCHWAD,PUNE	acegasindia@gamil.com	
		10081	ESAB INDIA LTD	KARUMUTTU CENTRE, 6TH FLOORNEW NO.634(OLD NO.498)ANNA SALAI, NANDANAM,CHENNAI-35CHENNAI	jagdeesh.ds@esab.co.in	044-826 9343
11288	JAGSHAAN INDUSTRIES	94 FRIENDS COLONYKATOL ROADNAGPUR	jagshaan@nagpur.dot.net.in	0712 - 581557		

**SECTION - VIII
LIST OF APPROVED VENDORS**

1) WELDING CONSUMABLES SUPPLIERS LIST

Mat Group	Material Group Description	Vendor No	Vendor Name	Vendor Address	EMAIL	PHONE1
		15100	MANTEK WIRES	24,SIDCO INDUSTRIAL ESTATE,P.VADUGAPALAYAM,PALLADAMCOIMBAT ORE		
		14340	NALLI ARC INDUSTRIE,	SF NO. 340,NALLIPALAYAM,PADIYUR POST,KANGAYAM TALUKERODE Dt.	nalliar@yahoo.com	04257 245185
		15101	PRECISION WELDARC LTD,	49,B.T. ROAD, PANIHATI24,PARGANAS (NORTH)KOLKATA.	pwires@yahoo.co.in	033 25634753
		14455	WIRE AND WIRE PRODUCTS	SIDCO INDUSTRIAL ESTATEAMBATTURCHENNAI	wwp@vsnl.net	044 26242378
		15810	NOUVEAUX INDUSTRIES (P) LTD.,	NO.2,SOWDAMBIGA NAGARTIRUPUR ROAD.KANGAYAM		
WCW02	WELDING WIRE:SAW EB3	20047	KANEMATSU TRADING CORPORATION	6th FLOOR,AKEBONO NIHONBASHI BLDG,19 - 5,NIHONBASHIKOAMI-CHO,CHUO - KU, TOKYO, 103 - 0016.	nikko-bocki@kgt.kanematsu.co.jp	81 3 5283 3680
		20563	BOHLER SCHWEISSTECHNIK	UNIONSTRASSE-1,D-59067 HAMM,DEUTSCHLAND GmbH.,GERMANY		
		20011	BOHLER SCHWEISSTECHNIK AUSTRIA	WERK DEUCHENDORF,A 8605, KAPPENBERG, POSTFACH - 9,AUSTRIA.AUSTRIA.		0043/3862301
WCW04	WG:WIRE:SAW ER430	20047	KANEMATSU TRADING CORPORATION	6th FLOOR,AKEBONO NIHONBASHI BLDG,19 - 5,NIHONBASHIKOAMI-CHO,CHUO - KU, TOKYO, 103 - 0016.	nikko-bocki@kgt.kanematsu.co.jp	81 3 5283 3680
		20033	KISWEL LTD.,	HEUNGKOOK B/D, 43-1,JUJA-DONGCHUNG-GU, C.P.O.BOX 8641SEOUL, KOREA.SEOUL,KOREA.	export@kiswel.com	82-2-2270-9400
WCW05	WG:WIRE:SAW ER410	20047	KANEMATSU TRADING CORPORATION	6th FLOOR,AKEBONO NIHONBASHI BLDG,19 - 5,NIHONBASHIKOAMI-CHO,CHUO - KU, TOKYO, 103 - 0016.	nikko-bocki@kgt.kanematsu.co.jp	81 3 5283 3680
		20033	KISWEL LTD.,	HEUNGKOOK B/D, 43-1,JUJA-DONGCHUNG-GU, C.P.O.BOX 8641SEOUL, KOREA.SEOUL,KOREA.	export@kiswel.com	82-2-2270-9400
WCW06	WELDING WIRE:SAW EB2	20047	KANEMATSU TRADING CORPORATION	6th FLOOR,AKEBONO NIHONBASHI BLDG,19 - 5,NIHONBASHIKOAMI-CHO,CHUO - KU, TOKYO, 103 - 0016.	nikko-bocki@kgt.kanematsu.co.jp	81 3 5283 3680
		20563	BOHLER SCHWEISSTECHNIK	UNIONSTRASSE-1,D-59067 HAMM,DEUTSCHLAND GmbH.,GERMANY		
		20011	BOHLER SCHWEISSTECHNIK AUSTRIA	WERK DEUCHENDORF,A 8605, KAPPENBERG, POSTFACH - 9,AUSTRIA.AUSTRIA.		0043/3862301

**SECTION - VIII
LIST OF APPROVED VENDORS**

1) WELDING CONSUMABLES SUPPLIERS LIST

Mat Group	Material Group Description	Vendor No	Vendor Name	Vendor Address	EMAIL	PHONE1
WCW08	WELDING WIRE:SAW EA4	20047	KANEMATSU TRADING CORPORATION	6th FLOOR,AKEBONO NIHONBASHI BLDG,19 - 5,NIHONBASHIKOAMI-CHO,CHUO - KU, TOKYO, 103 - 0016.	nikko-bocki@kgt.kanematsu.co.jp	81 3 5283 3680
		20011	BOHLER SCHWEISSTECHNIK AUSTRIA	WERK DEUCHENDORF,A 8605, KAPPENBERG, POSTFACH - 9,AUSTRIA.AUSTRIA.		0043/3862301
		20563	BOHLER SCHWEISSTECHNNIK	UNIONSTRASSE-1,D-59067 HAMM,DEUTSCHLAND GmbH.,GERMANY		
WCW09	WELDING WIRE:SAW EM1	20047	KANEMATSU TRADING CORPORATION	6th FLOOR,AKEBONO NIHONBASHI BLDG,19 - 5,NIHONBASHIKOAMI-CHO,CHUO - KU, TOKYO, 103 - 0016.	nikko-bocki@kgt.kanematsu.co.jp	81 3 5283 3680
		15810	NOUVEAUX INDUSTRIES (P) LTD.,	NO.2,SOWDAMBIGA NAGARTIRUPUR ROAD.KANGAYAM		
		10081	ESAB INDIA LTD	KARUMUTTU CENTRE, 6TH FLOORNEW NO.634(OLD NO.498)ANNA SALAI, NANDANAM,CHENNAI-35CHENNAI	jagdeesh.ds@esab.co.in	044-826 9343
		20563	BOHLER SCHWEISSTECHNNIK	UNIONSTRASSE-1,D-59067 HAMM,DEUTSCHLAND GmbH.,GERMANY		
WCW12	WELDING WIRE:SAW 3 B	20011	BOHLER SCHWEISSTECHNIK AUSTRIA	WERK DEUCHENDORF,A 8605, KAPPENBERG, POSTFACH - 9,AUSTRIA.AUSTRIA.		0043/3862301
		20563	BOHLER SCHWEISSTECHNNIK	UNIONSTRASSE-1,D-59067 HAMM,DEUTSCHLAND GmbH.,GERMANY		
		20047	KANEMATSU TRADING CORPORATION	6th FLOOR,AKEBONO NIHONBASHI BLDG,19 - 5,NIHONBASHIKOAMI-CHO,CHUO - KU, TOKYO, 103 - 0016.	nikko-bocki@kgt.kanematsu.co.jp	81 3 5283 3680
		10081	ESAB INDIA LTD	KARUMUTTU CENTRE, 6TH FLOORNEW NO.634(OLD NO.498)ANNA SALAI, NANDANAM,CHENNAI-35CHENNAI	jagdeesh.ds@esab.co.in	044-826 9343
		22391	AIR-LIQUIDE WELDING FRANCE,	13,RUE D'EPLUCHES-BP70024 SAINT-OUEN I'AUMONE,95315 CERGY PONTOISE CEDEX	jean-paul.shmitt@airliquide.com	1342 13480
		21411	METRODE PRODUCTS LIMITED,	HANWORTH LANE,CHERTESY,SURREY KT169LL,		

BHEL:BAP:Ranipet :: Outsourcing Department

Section-VIII - 2) List of approved vendors for procurement of Paints

SL-No.	Prod Description	SL-No	Supplier Name M/s.	Place
01	INTUMESCENT PAINT	01	AKZO NOBEL INDIA LIMITED	BENGALURU
	INTUMESCENT PAINT	02	CLEAN COATS PVT. LTD.	MUMBAI
	INTUMESCENT PAINT	03	NOBLE PAINTS PVT. LTD	MUMBAI
02	CHLORINATED RUBBER PAINTS	01	ASIAN PAINTS LTD	MUMBAI
	CHLORINATED RUBBER PAINTS	02	ASIAN PAINTS LTD	CHENNAI
	CHLORINATED RUBBER PAINTS	03	BERGER PAINTS INDIA LTD	KOLKATA
	CHLORINATED RUBBER PAINTS	04	BERGER PAINTS INDIA LIMITED	CHENNAI
	CHLORINATED RUBBER PAINTS	05	CARBOLINE INDIA PVT. LTD.,	CHENNAI
	CHLORINATED RUBBER PAINTS	06	JENSON & NICHOLSON LTD.,	KOLKATA
	CHLORINATED RUBBER PAINTS	07	SHALIMAR PAINTS	KOLKATA
	CHLORINATED RUBBER PAINTS	08	SHALIMAR PAINTS	CHENNAI
03	HEAT RESISTANT EPOXY PAINTS	01	ASIAN PAINTS LTD	MUMBAI
	HEAT RESISTANT EPOXY PAINTS	02	ASIAN PAINTS LTD	CHENNAI
	HEAT RESISTANT EPOXY PAINTS	03	BERGER PAINTS INDIA LTD	KOLKATA
	HEAT RESISTANT EPOXY PAINTS	04	BERGER PAINTS INDIA LIMITED	CHENNAI
	HEAT RESISTANT EPOXY PAINTS	05	CARBOLINE INDIA PVT. LTD.,	CHENNAI
	HEAT RESISTANT EPOXY PAINTS	06	JENSON & NICHOLSON LTD.,	KOLKATA
	HEAT RESISTANT EPOXY PAINTS	07	SHALIMAR PAINTS	KOLKATA
	HEAT RESISTANT EPOXY PAINTS	08	SHALIMAR PAINTS	CHENNAI
04	POLYURETHANE ACRYLIC PAINTS	01	ASIAN PAINTS LTD	MUMBAI
	POLYURETHANE ACRYLIC PAINTS	02	ASIAN PAINTS LTD	CHENNAI
	POLYURETHANE ACRYLIC PAINTS	03	BERGER PAINTS INDIA LTD	KOLKATA
	POLYURETHANE ACRYLIC PAINTS	04	BERGER PAINTS INDIA LIMITED	CHENNAI
	POLYURETHANE ACRYLIC PAINTS	05	CARBOLINE INDIA PVT. LTD.,	CHENNAI
	POLYURETHANE ACRYLIC PAINTS	06	JENSON & NICHOLSON LTD.,	KOLKATA
	POLYURETHANE ACRYLIC PAINTS	07	SHALIMAR PAINTS	KOLKATA
	POLYURETHANE ACRYLIC PAINTS	08	SHALIMAR PAINTS	CHENNAI
05	REDOXIDE ZINC CHROME PRIMER PAINT IS:2074	01	ADDISION PAINTS	CHENNAI
	REDOXIDE ZINC CHROME PRIMER PAINT IS:2074	02	ASIAN PAINTS LTD	MUMBAI
	REDOXIDE ZINC CHROME PRIMER PAINT IS:2074	03	ASIAN PAINTS LTD	CHENNAI
	REDOXIDE ZINC CHROME PRIMER PAINT IS:2074	04	BERGER PAINTS INDIA LTD	KOLKATA
	REDOXIDE ZINC CHROME PRIMER PAINT IS:2074	05	BERGER PAINTS INDIA LIMITED	CHENNAI
	REDOXIDE ZINC CHROME PRIMER PAINT IS:2074	06	BOMBAY PAINTS, CORRIDOR ROAD,	MUMBAI
	REDOXIDE ZINC CHROME PRIMER PAINT IS:2074	07	JENSON & NICHOLSON LTD.,	KOLKATA

SL-No.	Prod Description	SL-No	Supplier Name M/s.	Place
	REDOXIDE ZINC CHROME PRIMER PAINT IS:2074	08	NOBLE PAINT & VARNISH CO P LTD	CHENNAI
	REDOXIDE ZINC CHROME PRIMER PAINT IS:2074	09	PERIYAR CNSL WORKERS INDL.COOP	KUNDRAKUDI
06	RUST PREVENTIVE OIL	01	PLASTIPEEL CHEMICALS & PLASTIC	THANE
	RUST PREVENTIVE OIL	02	PROCESS AIDS	BENGALURU
	RUST PREVENTIVE OIL	03	SEMPER-SEAL CHEMICALS,	AGRA
	RUST PREVENTIVE OIL	04	THIN CHEMIE FORMULATIONS	CHENNAI
	RUST PREVENTIVE OIL	05	WESTERN (I) PAINT & COLOUR CO,	CHENNAI
07	SPECIAL PAINTS OF ALL TYPES	01	ASIAN PAINTS LTD	MUMBAI
	SPECIAL PAINTS OF ALL TYPES	02	ASIAN PAINTS LTD	CHENNAI
	SPECIAL PAINTS OF ALL TYPES	03	BERGER PAINTS INDIA LTD	KOLKATA
	SPECIAL PAINTS OF ALL TYPES	04	BERGER PAINTS INDIA LIMITED	CHENNAI
	SPECIAL PAINTS OF ALL TYPES	05	CARBOLINE INDIA PVT. LTD.,	CHENNAI
	SPECIAL PAINTS OF ALL TYPES	06	FOSROC CHEMICALS (I) LTD	BENGALURU
	SPECIAL PAINTS OF ALL TYPES	07	FOSROC CHEMICALS (INDIA) LTD	CHENNAI
	SPECIAL PAINTS OF ALL TYPES	08	JENSON & NICHOLSON LTD.,	KOLKATA
	SPECIAL PAINTS OF ALL TYPES	09	SHALIMAR PAINTS	KOLKATA
	SPECIAL PAINTS OF ALL TYPES	010	SHALIMAR PAINTS	CHENNAI
08	EPOXY BASED & FINISH PAINTS &ITS THINER	01	ASIAN PAINTS LTD	CHENNAI
	EPOXY BASED & FINISH PAINTS &ITS THINER	02	BERGER PAINTS INDIA LIMITED	CHENNAI
	EPOXY BASED & FINISH PAINTS &ITS THINER	03	GRAUER&WEIL(INDIA) LIMITED,	CHENNAI
	EPOXY BASED & FINISH PAINTS &ITS THINER	04	SHALIMAR PAINTS	CHENNAI
	EPOXY BASED & FINISH PAINTS &ITS THINER	05	AKZO NOBEL INDIA LIMITED	BENGALURU
	EPOXY BASED & FINISH PAINTS &ITS THINER	06	GRAND POLYCOATS CO.PVT LTD	VADODARA
09	SPECIAL PRIMER PAINTS AND ITS THINER	01	ASIAN PAINTS LTD	CHENNAI
	SPECIAL PRIMER PAINTS AND ITS THINER	02	BERGER PAINTS INDIA LIMITED	CHENNAI
	SPECIAL PRIMER PAINTS AND ITS THINER	03	GRAUER&WEIL(INDIA) LIMITED,	CHENNAI
	SPECIAL PRIMER PAINTS AND ITS THINER	04	SHALIMAR PAINTS	CHENNAI
	SPECIAL PRIMER PAINTS AND ITS THINER	05	AKZO NOBEL INDIA LIMITED	BENGALURU
	SPECIAL PRIMER PAINTS AND ITS THINER	06	KANSAI NEROLAC PAINTS LIMITED	CHENNAI
	SPECIAL PRIMER PAINTS AND ITS THINER	07	GRAND POLYCOATS CO.PVT LTD	VADODARA
010	CONVENTIONAL PAINTS & THINNER	01	ASIAN PAINTS LTD	CHENNAI
	CONVENTIONAL PAINTS & THINNER	02	BERGER PAINTS INDIA LIMITED	CHENNAI
	CONVENTIONAL PAINTS & THINNER	03	GRAUER&WEIL(INDIA) LIMITED,	CHENNAI
	CONVENTIONAL PAINTS & THINNER	04	CARBOLINE INDIA PVT. LTD.,	CHENNAI
	CONVENTIONAL PAINTS & THINNER	05	SHALIMAR PAINTS	CHENNAI
	CONVENTIONAL PAINTS & THINNER	06	WESTERN (I) PAINT & COLOUR CO,	CHENNAI

SL-No.	Prod Description	SL-No	Supplier Name M/s.	Place
	CONVENTIONAL PAINTS & THINNER	07	NOVAA PAINTS	TIRUCHIRAPPALLI
	CONVENTIONAL PAINTS & THINNER	08	SUNDARAM PAINTS (P) LTD	THANJAVUR
	CONVENTIONAL PAINTS & THINNER	09	KANSAI NEROLAC PAINTS LIMITED	CHENNAI
	CONVENTIONAL PAINTS & THINNER	010	SRI MEENAKSHI PAINT INDUSTRIES,	PUDUKKOTAI
	CONVENTIONAL PAINTS & THINNER	011	PASUM MEENA PAINT INDUSTRIES	SIVAGANGAI DIST
	CONVENTIONAL PAINTS & THINNER	012	JAI KAMAL PAINTS	CHENNAI
	CONVENTIONAL PAINTS & THINNER	013	CHEMECOAT PAINTS	TIRUCHIRAPPALLI
011	SEA WORTHY RUST PREVENTIVE OIL	01	SHALIMAR PAINTS	CHENNAI
	SEA WORTHY RUST PREVENTIVE OIL	02	SUNDARAM PAINTS (P) LTD	THANJAVUR
012	H.R.ALUMINIUM PAINT GRADE II TO IS:13183	01	ASIAN PAINTS LTD	CHENNAI
	H.R.ALUMINIUM PAINT GRADE II TO IS:13183	02	BERGER PAINTS INDIA LIMITED	CHENNAI
	H.R.ALUMINIUM PAINT GRADE II TO IS:13183	03	SHALIMAR PAINTS	CHENNAI
	H.R.ALUMINIUM PAINT GRADE II TO IS:13183	04	KANSAI NEROLAC PAINTS LIMITED	CHENNAI
	H.R.ALUMINIUM PAINT GRADE II TO IS:13183	05	STAR PAINT & OIL INDUSTRIES	MUMBAI
013	CONVENTIONAL PAINTS & THINNER	01	ASIAN PAINTS LTD	CHENNAI
	CONVENTIONAL PAINTS & THINNER	02	BERGER PAINTS INDIA LIMITED	CHENNAI
	CONVENTIONAL PAINTS & THINNER	03	GRAUER&WEIL(INDIA) LIMITED,	CHENNAI
	CONVENTIONAL PAINTS & THINNER	04	CARBOLINE INDIA PVT. LTD.,	CHENNAI
	CONVENTIONAL PAINTS & THINNER	05	SHALIMAR PAINTS	CHENNAI
	CONVENTIONAL PAINTS & THINNER	06	WESTERN (I) PAINT & COLOUR CO,	CHENNAI
	CONVENTIONAL PAINTS & THINNER	07	NOVAA PAINTS	TIRUCHIRAPPALLI
	CONVENTIONAL PAINTS & THINNER	08	SUNDARAM PAINTS (P) LTD	THANJAVUR
	CONVENTIONAL PAINTS & THINNER	09	KANSAI NEROLAC PAINTS LIMITED	CHENNAI
	CONVENTIONAL PAINTS & THINNER	010	SRI MEENAKSHI PAINT INDUSTRIES,	PUDUKKOTAI
	CONVENTIONAL PAINTS & THINNER	011	PASUM MEENA PAINT INDUSTRIES	SIVAGANGAI DIST
	CONVENTIONAL PAINTS & THINNER	012	JAI KAMAL PAINTS	CHENNAI
	CONVENTIONAL PAINTS & THINNER	013	CHEMECOAT PAINTS	TIRUCHIRAPPALLI

LEGEND :

Supplier Control :

1. Inspection at Supplier's works by BHEL / QC / Inspection agency appointed by BHEL
2. Inspection at Supplier's works by Customer / Third party
3. Inspection as per approved Quality Plan
4. Qualification of Suppliers Operators & Process for execution of the job
5. Sample approval required
6. Periodical Process audit by BHEL
7. Inspection after receipt at BHEL



Section-VIII- 3) PENETRANT TESTING CHEMICALS AND
MAGNETIC TESTING CONSUMABLES

PENETRANT TESTING

**PENETRANT TESTING CHEMICALS
DYE (SOLVENT REMOVABLE, FLUORESCENT, WATER WASHABLE, POST
EMULSIFIER) , DEVELOPER, CLEANER**

Sl.No	Vendor address	Approved by
1.	P-MET HIGH-TECH COMPANY (P) LTD. 1-5/6,INDUSTRIAL ESTATE, GORWA, BARODA (GUJARAT) INDIA-390016 PHONE NO.: 0265-282326/281125 FAX : 0265-2793868 E-MAIL : P-MET@ICENET.NET	TRICHY HYDERABAD RANIPET HARIDWAR
2.	ORIENTAL CHEMICAL WORKS (P) LTD 23 SATTANA NAICKEN STERRET 1ST LOOR,SRIVISHAKANYA NILAYAM, ADJACENT STREET, NATRAJ THEATRE CHENNAI 600 112	TRICHY RANIPET
3.	ITW SIGNODE INDIA LTD 3RD FLOOR,MERCHANT TOWERS, 5,ROAD NO.4,BANJARA HILLS HYDERBAD 500 034 E MAIL : VARDA@TCH.ITWSIGNODE.CO.IN Ph.No: 044 -24723956	TRICHY HYDERABAD RANIPET
4.	ITW SIGNODE INDIA LTD PLOT NO 34-37, IDA , APIIC, PASHAMNYLARAM, PHASE-II, MEDAK INDIA -502307 PHONE NO.: 08455- 26089, 26055 , 26328 FAX : 08455-26336 EMAIL: dst@fps.itwsignode.co.in	TRICHY HYDERABAD RANIPET HARIDWAR
5.	ITW SIGNODE INDIA LTD. 10, COMMUNITY CENTRE, EAST OF KAILASH, NEW DELHI , INDIA -110065 PHONE NO.: 01126424984, 01126424990	TRICHY HYDERABAD RANIPET HARIDWAR
6.	PRADEEP METAL TREATMENT CHEMICALS (P) LTD. PLOT NOS A-488/489, ROAD U, WAGLE INDUSTRIAL ESTATE, THANE ,INDIA -400604 PHONE NO.:022-5598 8781 / 82 , FAX : 022-2582 7460 E-MAIL : pradeepndt@mtnl.net.in	TRICHY HYDERABAD RANIPET HARIDWAR
7.	FERROCHEM, 1,GURUPRASAD KUNU 1122/6 ERANDAWAANA PUNE 411 004	TRICHY HYDERABAD RANIPET



Section-VIII- 3) PENETRANT TESTING CHEMICALS AND
MAGNETIC TESTING CONSUMABLES

8.	FERROCHEM NDT SYSTEMS PVT. LTD 6, PRAGATI INDUSTRIAL COMPLEX, 17/1-B, KOTHRUD, PUNE (MAHARASHTRA) INDIA -411004 PHONE NO.: (020)5465258/5432528/5437339 FAX : 5463038 E-MAIL : ferro@pn2.vsnl.net.in	TRICHY HYDERABAD RANIPET HARIDWAR
9.	ANDHRA SPARES COMPANY SHOP NO: 5-5-80/2, 1ST FLOOR, SRI SRINIVASA COMMERCIAL COMPLEX, RANIGUNJ, SECUNDERABAD- 500 003	HYDERABAD
10.	CHECKMATE CHEMICALS LTD, 13, MODERN INDUSTRIAL ESTATE, ROHTAK ROAD, BAHADUR GARH, HARYANA 124 507	TRICHY HYDERABAD RANIPET
11.	CHECKMATE CHEMICALS PVT. LTD. EC-11, 2ND FLOOR, INDER PURI, NEW DELHI , INDIA , 110012 PHONE NO.: 011-2585889/25835870 FAX : 011-25833160 E-MAIL : dlsharma@vsnl.com	TRICHY HYDERABAD RANIPET HARIDWAR
12.	NDT CHEMICAL PRODUCTS, 5-7-9/6, SANGEETH NAGAR, KUKATPALLY, HYDERABAD-500 072. EMAIL: ndtcp787_hyd@dataone.in WEB: WWW.NDTCPHYD.COM PHONE: 09246530958	HYDERABAD
13.	THE ORIENTAL CHEMICAL WORKS, KOLKATTA 1/1B, GOBINDA AUDDY ROAD, CHETLA, KOLKATA-700 027	HYDERABAD
14.	M /S KRISH MET TECH PVT LTD 10 /1ST FLOOR, ARUNACHALAM ROAD,(OPP.SURRYA HOSPITAL) SALIGRAM,CHENNAI 600 093 EMAIL KRISHMETTECH@ETH.NET PH 23761491, 23764450	TRICHY RANIPET



Section-VIII- 3) PENETRANT TESTING CHEMICALS AND
MAGNETIC TESTING CONSUMABLES

MAGNETIC TESTING CONSUMABLES
DRY POWDER

Sl.No	Vendor address	Approved by
1.	ITW SIGNODE INDIA LTD 3RD FLOOR, MERCHANT TOWERS, 5, ROAD NO.4, BANJARA HILLS HYDERBAD 500 034 E MAIL: varda@tch.itwsignode.co.in 044 -24723956	TRICHY HYDERABAD
2.	FERROCHEM NDT SYSTEMS PVT. LTD 6, PRAGATI INDUSTRIAL COMPLEX, 17/1-B, KOTHRUD, PUNE (MAHARASHTRA) INDIA-411004 PHONE NO.: (020)5465258/5432528/5437339 FAX : 5463038 E-MAIL : ferro@pn2.vsnl.net.in	TRICHY HYDERABAD
3.	EAST COAST ENTERPRISES 33, BRABOURNE ROAD, P.BNO. 2217 GPO CALCUTTA 700 001	TRICHY HYDERABAD
4.	ELECTRO MAGFIELD CONTROLS & SERVICES 561 G.M.T.H ROAD (NEAR TELEPHONE EXCHANGE) AMBATHUR CHENNAI 600 098 EMAIL: emcs@eth.net PH 625 4327, 652 1041	TRICHY HYDERABAD
5.	EAST WEST ENGG. & ELECTRONICS CO 204, ACHARYA COMMERCIAL CENTRE DR. C. G. ROAD, CHEMBUR MUMBAI 400 074	TRICHY HYDERABAD
6.	KIRAN ENTERPRISES PLOT NO 175, PRAGATHINAGAR, OPP. JNTU KUKATPALLY, HYDRABAD 500 072	HYDERABAD
7.	PARADEEP NDT PRODUCTS REGIS. OFFICE: 32 WESTMINSTER, MANIKIKAR MARG, CHUNABHATTI, SION, MUMBAI-400 022 WORKS: SHED NO.3, CHANDRASAKHA ESTATE SURVEY NO.1, AMBEGAON BUORUK TAL.HAVELI DIST. PUNE 411 046 PHONE NO. 020 -24210699	TRICHY HYDERABAD



Section-VIII- 3) PENETRANT TESTING CHEMICALS AND
MAGNETIC TESTING CONSUMABLES

8.	PRADEEP METAL TREATMENT CHEMICALS (P) LTD. PLOT NOS A-488/489, ROAD U, WAGLE INDUSTRIAL ESTATE, THANE ,INDIA-400604 PHONE NO.: 022-5598 8781 / 82, FAX : 022-2582 7460 E-MAIL : pradeepndt@mtnl.net.in	
----	---	--

MPI CHEMICALS (WET)

Sl.No	Vendor address	Approved by
1.	CHECKMATE CHEMICALS PVT. LTD. EC-11, 2ND FLOOR, INDER PURI, NEW DELHI , INDIA -110012 PHONE NO.: 011-2585869/25835870 FAX : 011-25833100 E-MAIL : dbsharma@vsnl.com	TRICHY HYDERABAD BHOPAL HARIDWAR
2.	P-MET HIGH-TECH COMPANY (P) LTD. 1-5/6,INDUSTRIAL ESTATE, GORWA, BARODA (GUJARAT) INDIA -390016 PHONE NO.: 0265-282326/281125,FAX : 0265-2793868 E-MAIL : p-met@icenet.net	TRICHY HYDERABAD BHOPAL HARIDWAR
3.	K ELECTRONICS G11 ,RAJMAHAL, 55-E,M. VASANJI ROAD ANDHERI(EAST) MUMBAI 400 089 PHONE:020-25432528,25437339 FAX:020-25463038 E-MAIL: ferro@pn2.vsnl.net.in	TRICHY HYDERABAD BHOPAL
4.	PRADEEP METAL TREATMENT CHEMICALS (P) LTD. PLOT NOS A-488/489, ROAD U, WAGLE INDUSTRIAL ESTATE, THANE , INDIA, 400604 PHONE NO.: 022-5598 8781 / 82 , FAX : 022-2582 7460 E-MAIL : pradeepndt@mtnl.net.in	TRICHY HYDERABAD BHOPAL HARIDWAR
5.	PRADEEP NDT PRODUCTS PVT. LTD. 32, WESTMINISTER, MANKIKAR MARG, SION, MUMBAI - 400 022 PHONE:022-24073309, 24093118 pradeepndt@vsnl.net vardeji@bol.net.in	TRICHY HYDERABAD BHOPAL



Section-VIII- 3) PENETRANT TESTING CHEMICALS AND
MAGNETIC TESTING CONSUMABLES

6.	ITW SIGNODE INDIA LTD PLOT NO 34-37, IDA , APIIC, PASHAMNYLARAM, PHASE-II MEDAK, INDIA -502307 PHONE NO.: 08455- 26089, 26055 , 26328 ,FAX : 08455- 26336 EMAIL: dst@fps.itwsignode.co.in	TRICHY HYDERABAD BHOPAL HARIDWAR
7.	ITW SIGNODE INDIA LTD 3 RD FLOOR, MERCCHANT TOWERS, 5, ROAD NO 4, BANJARA HILLS, HYDERABAD-500034 PHONE: 040-23353781 E-MAIL: itwindia@hdl.ven.net.in	TRICHY HYDERABAD BHOPAL
8.	ITW SIGNODE INDIA LTD. 10, COMMUNITY CENTRE, EAST OF KAILASH, NEW DELHI, INDIA - 110065 PHONE NO.: 01126424984, 01126424990	TRICHY HYDERABAD BHOPAL HARIDWAR
9.	FERROCHEM NDT SYSTEMS PVT. LTD 6, PRAGATI INDUSTRIAL COMPLEX, 17/1-B, KOTHRUD, PUNE (MAHARASHTRA) ,INDIA-411004 PHONE NO.: (020)5465258/5432528/5437339, FAX : 5463038 E-MAIL : ferro@pn2.vsnl.net.in	TRICHY HYDERABAD BHOPAL HARIDWAR

RATE CONTRACT 2014 – Ranipet :: Outsourcing Department
SECTION – VIII
4) LIST OF NDT APPROVED VENDORS

Sl.No	NDT Agency Address	Methods
1.	M/s. G.B. NdtEngg. Services, E-52,Industrial Estate,Thuvakudi, Tiruchy, Tamilnadu-620015 Phone:(0431)2501112,2500891, 09842450112(Vivek) Email:gbdnt.xrayengg@yahoo.com	RT,UT,MT,PT
2.	M/s. Super Quality Services, 95,Sqs Building, Near Police Station, Palakkarai Main Road, Trichy-620001 Phone (0431)2415087,2414218, 09843054218(Tamilselvan) FAX-0431-2464218 Email:sqsndt@yahoo.co.in	RT,UT,MT,PT
3.	M/s. Kgb Inspection Services, P-16, Electrical&Electronics Industrial Estate, Thuvakudi, Tiruchirappalli 620015 Ph(0431)2500164, 09842453258(Kumaran) email:kgbist2002@yahoo.co.in	RT,UT,MT,PT
4.	M/s. Supreme Excel Ndt Services, li Floor, Vairam Memorial Complex 24-A/B, Jeeva Street, Subramaniapuram, Tiruchirappalli - 620020 Phone:(0431)2333528, 2501241,09842452075(Subramanian) e-mail:ndtsrvcs2008@yahoo.co.in	RT,UT,MT,PT
5.	M/s. Bharat Inspection Services, 1-19,Electrical & Electronics Industrial Estate, Thuvakudi, Trichy-620015 Phone:0431-2500550 MOBILE: 9444435196 (Ramasamy), 9842536801(Shanmugavel) e-mail: ramasamyndt@rediffmail.com	RT,UT,MT,PT
6.	M/s. J K Inspection Services, Plot No. 47, Sidco, Bhel Ancillary Estate, Ranipet ,Tamilnau-632406.	RT,UT,MT,PT
7.	M/s. Scaanray Metallurgical Services, C-12, Industrial Estate,Mogappair (West) Chennai 600 037 Phone: 044-26250651, 23762613 FAX 26358741, 9840104928(Pari),9840050651(Nakkeran) Email: scaanray@vsnl.com	RT,UT,MT,PT
8.	M/s. Ascent NdtServices, F-3, 1st Floor, P.S.Paradise, 73/34, 7th Avenue, Ashok nagar, Chennai-600083, Phone:044-24740075, 42033696, e-mail: qitcschennai@yahoo.co.in, qitcschennai@gmail.com	RT,UT,MT,PT
9.	M/s. GLOBAL NDT SERVICES, 22, Thuthipet, Thuthipet Post, VELLORE, Tamilnadu-632 011 Ph:09944726802, 09442261909(Mohanraj), 9865911211(Robert) , Email:gns.ndt@gmail.com	RT,UT,MT,PT
10.	M/s. Baroda Equipment And Vessels (P) Ltd Block 241-242, Muvai-Mobha Road, Muvai P.O, Ta-Padra, Vadodara, Gujarat State-391430 , Phone:02662-243100 9 email:info@barodaequip.com	RT,UT,MT,PT
11.	M/s. International Radiography Services, A-75 / 3 / 5, General Block, M.I.D.C, Telco- BhosariRoad,Bhosari, Pune, Maharashtra State- 411 026 Phone:020-27129659, 27129660, Mobile:09922194031Borkar) Email:irsndt@rediffmail.com	RT,UT,MT,PT
12.	M/s. Becquerel Industries Pvt.Ltd., Plot 33, Rushikesh, Ingole Nagar, Modern Coop. Housing Society, Wardha Road, Nagpur, Maharashtra State- 440 005 Ph: 0712-2284352, FAX: 0712-2286665, Mobile: 09822565879 Email: becquerel-ndt@rediffmail.com, Becquerel-ndt@gmail.com, www.info.apliedndt.com	RT,UT,MT,PT
13.	M/s. Sakthi Radiographic Inspection Company, No 1 / 1-14, Rajiv Gandhi Nagar, Walajapet,Tamilnadu-632 513 Phone 04172-230344, 245264, Cell:9443246128 email:srico_ndt@yahoo.com	RT,UT,MT,PT
14.	M/s. Evergreen Ndt Engineers, No. 7, I Floor, Vairam Memorial Complex , 24-A/B, Jeeva Street, Subramaniapuram, Tiruchirappalli20- 620020 Phone(0431) 2333095, Cell- 9842425765(Chockalingam), 9842435765(Ravichandran) email:enetry20@eth.net	RT,UT,MT,PT
	M/s. Metal Care Engg. Services Plot 13,14, B-1 Kether Manor, 3rd Cross, North Extension, ThillaiNagar,Trichy 620018 Phone(0431) 2762190, 2481593 9942904651(Selvaraj) Email: mces_try@yahoo.co.in	RT
16.	M/s. Institute Of Inspection Technology And Ndt Resources, 31, Rubin Complex, las Nagar, Thiruverumbur, Trichy-620013 Phone 0431-2512269, Cell:Rajendran-09865007583, Shareef-9865407475 Email:info@iitndt.com	RT
17.	M/s. Madras Radiography Engineers Ramanathapuram Road, Eranthangal Village & Post, Vellore Dist, Tamilnadu-632519 Ph: 09448040882(Damodaran), Email:Mrs.India@Gmail.Com 705, 3rd Cross, Hrbr I Block, Kalyan Nagar, Bangalore-560 043 Ph:080-25453228, 25453229 E-MAIL: mre@dataone.in, mre.ndt@gmail.com	RT

18.	M/s. National Radiographic Inspection Co No 5 / 1, Sidco Industrial Estate, Thuvakudi, Trichy-620015. Phone:0431-6522046, Mobile: 750964404(Mariappan) e mail:snmoorthy64@yahoo.com, snmoorthy@nricndt.com H.O A22,F/1, Brindavanam Flats, 5th Avenue, Banu Nagar, Pudur, Chennai- 600 053 Phone:9445745193(Moorthy) 044-26862363, Email:snmoorthy64@yahoo.com, snmoorthy@nricndt.com	RT
19.	M/s. Sitas 472 / 1,2,3,Sendampalayam MgcPalayam Village, AvinashiTaluk, SsKulam Via Coimbatore-641107, 9442233493(Saravanan) e-mail: sitascbe@yahoo.co.in	RT
	M/s. H.O C-72, Iii Stage,Peenya Industrial Area, Bangalore- 560058 Ph: 080 28368899,41171123,Fax:08028365544 e-mail:teamsitas@yahoo.com, info@sitasndt.com, Web:www.sitasndt.com	
20.	M/s. Gb Engineering Enterprises (P) Ltd, D99, Developed Plot Estate, Thuvakudi, Trichy-620015 Phone:0431-3041000, Fax:0431-3041050 Mobile: 9345121115 gb@gb.resurgent.in	RT,UT,MT,PT
21.	M/s. Shanmukandt& Inspection Services, 701, Avoor Road, Mathur, Pudukottai District-622515, Phone:04339- 250822 Mobile:9486675664(Saravanan)9443179425(Muthuku mar), Email:shanmukandt@gmail.com	RT
22.	M/s. Sievert India Pvt.Ltd, Plot No 24, Haji Ismail Nagar, Thiruverumbur, Trichy-620013, Phone&Fax:0431-2511545, Mobile:9500811003(Hariprasad) email:cbala@sievert.in. hariprasadj@sievert.in, H.O 16&17,PLOT NO 2 SECTOR-2,PHASE II, NERUL, NAVI MUMBAI-400706 Ph:022 27732003,27732004, Fax:022-22727076 emil:venkat@sievert.in	RT
23.	M/s. Industrial X-Ray Inspection Company, Test House, 26, 2nd Street, Kalaimagal Nagar, Eekkattuthangal, Chennai 600 032 Phone: 044- 22251091, 22250690 , 9840076744(Venkatesh)9003075206(Baskar) e-mail: ixicoc@gmail.com	RT
24.	M/s. Industrial Radiographic Inspection Company Sp-111, South Avenue, Ambattur Industrial Estate, Chennai 600 058 Phone: 044- 26253235,26250790,26255602,Fax-044-26255838, Mobile9444418045(Sathyan) e-mail : iricondt@airtelmail.in	RT
25.	M/s. United Inspection And Engineering Services, New No 9, Old No 22, Parthasarathypuram, North Usman Road, T.Nagar, Chennai 600 017. Phone:044- 42123180, Fax: 044-28142268, Cell:Leeladhar 9444062268, E-mail:uies@sify.com.	RT
26.	M/s. Engineering Quality Inspection Services, 2 / 166 A, Mettukuppam Road, Vanagaram, Chennai- 600 095. Phone:044-24764770, Fax:044-24764773, E-mail: jstephenraj.eqis@gmail.com, 9884716100(Stephenraj)	RT,UT,MT,PT
27.	M/s. Jai Inspection Agencies, Plot No 21, Natesan Nagar, Ayanampakkam, Chennai- 600 095, Phone: 044-26533028,Fax: 044-26531770, Mobile9444376055(Durairaj) email: jai_ ndt@yahoo.com	RT
28.	M/s. Industrial X-Ray &Allied Radiographers(I) Pvt.Ltd, Plot 53, 4-457, 1st Street, Rayalanagar, Ramavaram, Chennai-600089 Phone 04422493387, 04427291026 Mobile 9865069804(Palanivel) Email:gpalanivel@ixar.in	RT
29.	M/s. Ascent Ndt Services, F-3, 1st Floor, P.S.Paradise, 73/34, 7th Avenue, Ashok Nagar, Chennai-600083, Phone:044-24740075, 42033696, e-mail: qitcschennai@yahoo.co.in, qitcschennai@gmail.com	RT,UT,MT,PT
30.	M/s. Global Ndt Services, 22, Thuthipet, Thuthipet Post, Vellore, Tamilnadu-632 011 Ph:09944726802, 09442261909(Mohanraj), 9865911211(Robert) Email:gns.ndt@gmail.com	RT,UT,MT,PT
31.	M/s. Testrade Technical Services, Vishnu Vihar,217, Dr. Ambedkar Road, P.O. Velandipalayam, Coimbatore 641 025. Phone: 0422-2450440 email:testradexray@gmail.com Site Office: 165, SidcoIndl.Estate, Malumichampatti, Coimbatore-641021 Phone:0422-2655772 Cell:9363242722	RT
32.	M/s. Everest Industrial Radiographer, 1/25, Arisipalayam, Coimbatore-641032 Phone:0422-2638148,2638348, Cell:9843011031 (A.Rathinam) email: everestndt@sify.com)	RT

33.	M/s. Sri VinayagaNdt Inspection Services, Sf 303, PeriaThottam, Kadathur Road, Coimbatore- 641 107. Phone 0422-2653640, 9443027274(Shanmugam) email:svndt@yahoo.co.in	RT
34.	M/s. Technical Inspection Services 513-A6, Bharathi Road, Chinnavedampatti, Ganapathy, Coimbatore-641 006. Phone:0422-2667971 Email:tisnssasi@yahoo.com	RT
35.	M/s. HitecNdt Systems S.F.No 350 / 2c, Near Rosver Steels Ltd,) KattampattiVillage, Ganesapuram P.O ,S.S.Kulam (Via) Coimbatore-614 107 Phone:0422-2653446 Mobile:9994975097(Ravikumar)Email: hitecndt@yahoo.in)	RT
36.	M/s. Escon Technical Services (P).Ltd 32, Bharathy Park Cross Road 8 , Coimbatore, 641011 Phone:0422-2451263, 2450737 Fax- 2437271 e-mail:indiaesconin@dataone.in	RT,UT
37.	M/s. Visvesvaraya Industrial Engineering Works,, Sf 238 / 2b & 2c , MasagoundanChettipalayam Village Telungupalayam Road, Annur, AvinasiTaluk, Coimbatore-641 653 Fax0422-2677725, Mobile:9444418051: 9444954613(N.S.Ravi) 9444418046 (N.Ananthkrishnan) e-mail: view_ndt@yahoo.com	RT
38.	M/s. Sri Amman Ndt System, 76/ 2a,2b,Thirumalayampalayam Village, Madukkarai P.O. Coimbatore-641105 Phone;0422-2402456, 2656290 Mobile:9865270800(Devaraj) email:sriammandt@yahoo.in	RT
39.	M/s. Test Ray's Inspection Services, S.F 413 / 3b, MopperiPalayam, PalladamTaluk, Coimbatore-642654. Ph:0421-3269845, Mobile9600944001, 02,03. Email:tiesndt@gmail.com	RT
40.	M/s. Coimbatore Industrial Radiographers, S.F.No 221, TherkkuThottam, OthakkalMandapam, Coimbatore-641032. Mobile:99443243201, email:cirndt@gmail.com	RT
41.	M/s. Curie Best Services, 359 / 1,2 Kanthampalayam, Sembianallur(Village), Avinashi-641654 Mobile:9486774627(Balakrishnan) 9942984241(Murugappan) email:curiebestservices@gmail.com	RT
42.	M/s. Industrial X-Ray & Allied Radiographers (I) Pvt.Ltd. 102, Faizan Apartments, 1st Floor, S.V.Road, Jogeshwari(West), Mumbai. 400102.	RT
43.	M/s. Isotope Teknica Ltd., Anjaney,, Plot No.3,Road-16, New Panvel,Navi Mumbai-410206.	RT
44.	M/s. Technical Testing Services, G.K.House, Harichand Mill Compound, Vikroli (West), Mumbai-400072.	RT
45.	M/s. International Radiography Services, A-75 / 3 / 5, General Block, M.I.D.C, Telco- Bhosari Road, Bhosari, Pune, Maharashtra State- 411 026 Phone:020-27129659, 27129660, Mobile:09922194031Borkar) Email:irsndt@rediffmail.com	RT,UT,MT,PT
46.	M/s. Essteeam Enterprises 42, Surendra Nagar, Nagpur, Mharashtra State-440015 Phone:071-2224362 Mobile:09422147029(PravinV.Pande E-Mail:essteeam.27@rediffmail.com	RT
47.	M/s. Seam(Sunil Hitech Engineers & Manufacturers P Ltd,) 97, East High Court Road, Ramdaspath, Nagpur, Maharashtra State-440010 Phone: 0712-2562087 / 88 , Mobile-Devarajan- 09923755592 E-mail:seamngp@gmail.com, info@seamlimited.com Works-K-43 / 2, Five Star Industrial Zone, MidcButibori, Nagpur, Maharashtra State-441122 Works: 07104-265468, 321968 :Fax:07104265467	RT,UT
48.	M/s. MetafabHightech (P) Ltd E 21-25, Midc, Industrial Area, Hingna Nagar, Nagpur-440 028 Ph:07104-234240 E-Mail:mfhpl@hotmail.com	RT,UT
49.	M/s. Becquerel Industries Pvt.Ltd (Applied Ndt& Technical Services), 33, Rushikesh, Ingole Nagar, Wardha Road, Nagpur, Maharashtra State- 440 005 Phone: 0712-2284352, Fax: 0712-2286665, Mobile: 09822565879(Jhime0 Email:becquerel_ndt@rediffmail.com, becquerel_ndt@gmail.com Website:info.apliedndt.com	RT,UT,MT,PT
50.	M/s. Metalscan Techniques, 302,Saraswati Sadanam Complex, Dharampeth, Nagpur-Maharashtra.440010 Phone:0712-2560989, 09422339219 email:metalscantechiques@rediffmail.com, kulkarnidinesh1@rediffmail.com	RT
51.	M/s. Purvanchal Inspection & Radiography Services, 758, Prem Nagar, Street No.7, Yamuna Nagar. Haryana- 135001	RT

52.	M/s. Modern Fabricators Engg. &Ndt System, Shop No. 2, Modern Colony, Kansepur Road, Yamuna Nagar. Haryana- 135001	RT
53.	M/s. Northern Industrial Radiography Services M-31, Industrial Area, On 200 Quarter Road,, Yamuna Nagar-135 001 Ph: 01732-251128, 253286 :FAX:01732-253286 EMAIL:nirsndt@yahoo.co.in CELL:09896330186 (SANJAY GUPTA)	RT,UT
54.	M/s. IrcEngg. Services India Pvt. Ltd. 612, Chiranjiv Tower, Nehru Place New Delhi- 110019.	RT
55.	M/s. Satyakiran Engineers Pvt.Ltd. Flats 3 & 4, Bu-Sfs, UttariPitampura, Delhi – 110088.	RT
56.	M/s. GlobalEngineering&Ndt Services Hasimpur, Patuligram P.O, Hoogly District, West Bengal-712 501 Cell 09831609926(S.Das) 9831626059(S.Sarkar) email:globalenggnndt@gmail.com	RT
57.	M/s. Perfect Inspection Services, Plot No 3, Gole Market, Vaishali Nagar, Bhilai-490 023 PH:0788-2221729 E-MAIL:pisbhillai@sify.com dkdutta7@yahoo.com	RT
50.	M/s. Metalscan Techniques, 302,Saraswati Sadanam Complex, Dharampeth, Nagpur-Maharashtra.440010 Phone:0712-2560989, 09422339219 email:metalscantechiques@rediffmail.com, kulkarnidinesh1@rediffmail.com	RT
51.	M/s. Purvanchal Inspection & Radiography Services, 758, Prem Nagar, Street No.7, Yamuna Nagar. Haryana- 135001	RT
52.	M/s. Modern Fabricators Engg. &Ndt System, Shop No. 2, Modern Colony, Kansepur Road, Yamuna Nagar. Haryana- 135001	RT
53.	M/s. Northern Industrial Radiography Services M-31, Industrial Area, On 200 Quarter Road,, Yamuna Nagar-135 001 PH: 01732-251128, 253286 :FAX:01732-253286 EMAIL:nirsndt@yahoo.co.in CELL:09896330186 (SANJAY GUPTA)	RT,UT
54.	M/s. IrcEngg. Services India Pvt. Ltd. 612, Chiranjiv Tower, Nehru Place New Delhi- 110019.	RT
55.	M/s. Satyakiran Engineers Pvt.Ltd. Flats 3 & 4, Bu-Sfs, UttariPitampura, Delhi – 110088.	RT
56.	M/s. GlobalEngineering&Ndt Services Hasimpur, Patuligram P.O, Hoogly District, West Bengal-712 501 Cell 09831609926(S.Das) 9831626059(S.Sarkar) email:globalenggnndt@gmail.com	RT
57.	M/s. Perfect Inspection Services, Plot No 3, Gole Market, Vaishali Nagar, Bhilai-490 023 Ph:0788-2221729 E-MAIL:pisbhillai@sify.com dkdutta7@yahoo.com	RT
58.	M/s. Infra Test House, 143 / D, Light Industrial Area, Bhilai-490026 ChattisgarhState Cell: 09993785454 e-mail: infratesthome@gmail.com, ssarbbajna@rediffmail.com	RT
59.	M/s. Inspection & Testing Engineers D-155, Sector 49, Noida, Up 201307. Ph; 0120-250065 Fax:0120-4310675 Cell:09810059715-A.K.Pawar E-Mail: lte.Noida@Hotmail.Com	RT
60.	M/s. Nde Inspections, 50,Raja Colony, 4th Cross, Collector Office Road, Trichy-620001. Phone (0431)2416388 , 9345499916 e-mail:ndeinspections@gmail.com, www.rla-ndeinspections.com	UT,MT,PT
61.	M/s. Scientech Inspection Services No 64-B, PanchaliammanKoil Street, Arumbakkam, Chennai-600 106 PH:044 6461720 FAX: 044 24750173 CELL: 9884022861, 9884022862 E-MAIL:scientechinspection@gmail.com	UT,MT,PT
62.	M/s. Baroda Equipment And Vessels Pvt Ltd, Block 241-242, Muvai-Mobha Road, Muvai P.O, Ta-Padra, Vadodara, Gujarat State-391430 Phone:02662-243100 Fax:02662-243099 email:info@barodaequip.com	RT,UT,MT,PT
63.	M/s. Ndts India (P) Ltd, 612, The Great Eastern Galleria, Plot No 20, Sector 4, Nerul, Navi Mumbai-400 076. PH:022-27703913, 27703923, 09321730516 (MukeshArora), 09322308492(Prasad Kunder) E-MAIL:info@ndts.co.in & prasad@ndts.co.in	MT,PT
64.	M/s. Metalab 42 A,Industrial Area, Govindpura Bhopal-462023	RT,UT,MT,PT
65.	M/s. Kwality Technical Services 245,Sector 9b, Saket Nagar, Bhopal-462024	UT,MT,PT
66.	M/s. Qualisurance Services & Consultancy, Plot No 3, BhawaniMohini, Bhawani Nagr,Bhopal-462021	UT,MT,PT
67.	M/s. PetromarinesNdt Engineers, F-31,32, RajatJayanti Complex, Sheme No 54, Indore-10	UT,MT,PT

68.	M/s. Technical Testing Services Site: Lig-100, Bhel, R.C.Puram, Hyd-502 032 H.O:G.K.House, Harichand Mills Compound L.B.S.Marg, Vikroli (W), Mumbai-400 079 Mr.M.R.Krishna 241323, 56294182 Mr.Mohan-9246590730, 23523448	RT
69.	M/s. Gamma Weld Inspection Services B5, Cis, Balanagar, Hyderabad- 500 037 Mr.Kaganalli 040-55572240 9391046437, Fax.No.040-23777469	RT,UT,MT
70.	M/s. S.M.S. Metallurgical Services 1-18, Behind Gati Transport, R.C.Puram, Hyd-32. Mr.Riaz 55642240, 9849075709 Mail Id: smslabs@yahoo.com	UT,MT
71.	M/s. Hyderabad Engineering Labs 5-36/26/B, Prasanthinagar, I.E.Kukatpalli, Hyd-500 072 Mr.Kaganalli 23075850, 55277870 9391048538, Fax.No. 040-23079235	RT,UT,MT
72.	M/s. Kumar Inspection Services H.No.23-28/2, Sri SaiSadan Complex, Beside Andhra Bank, Jyothi Nagar, Hyd-502 032 Mr.SamojiAnand.B 08455241323, 9963439251, 9396229170	RT
73.	M/s. EnconNdt Services 3-12-122, Ganesh Nagar, Ramanthpur, Hyderabad-13 Mr.NagendraBabu 040-27036665, 9849009103	RT,UT,MT
74.	M/s. Industrial X-Ray And Allied Radiographers (Pvt) Ltd 102, FaizanAppartments, 1st Floor, S.V.Road, Jogeswari (W), Mumbai-400 102 Mr.O.Jacinti/ M.R.Krishna 09323843448 Mail Id : ixar@yahoo.com	RT
75.	M/s. Jyothi Spectra Analysis Balanagar, Hyderabad Mr.Santosh-9849003761	UT,MT
76.	M/s. Quality Inspection Technologies, B-88, Auto Nagar, Visakhapatnam-530 012. Andhra Pradesh Mr.S.N.Moorthy 9000253935, 9849677299 Mail id : info@qindt.com snmoorthy@qindt.com	RT,UT,MT
77.	M/s. N.S.Engineering Company Pvt.Ltd, Unit No: B-28, Bhel, A.I.E, R.C.Puram, Hyd. G.Mallikarjunarao, 09399948488, 040- 20347989	UT,MT
78.	M/s. Ge Godavari Engineering Ltd, Mumbai National Highway-9, Patancheru,-502 319 B.K.Karande, 08455248500, 08455248501 mail id: geigodavari@sancharnet.in	RT
79.	M/s. Iso Tech Services B-89, Autonagar, Visakhapatnam- 530 012 P.Prabhakar 891 2512833(O), 891 2513178, 98499 16876	RT
80.	M/s. Axis Inspection Solutions, 201, Krishna Residency, Plot-15, Nizam Pet, Kukat Pally, Hyderabad- 500 072. V.Venkat Reddy 0919866324742, 09490426403 mail id : axis.ndt@gmail.com; hyd@axis-inspection.com	RT,UT,MT
81.	M/s. Industrial Radiographic Corporation Plot No: 115&116, Autonagar, Visakhapatnam-530 012 V.R.K.Murthy, Ph.No: 2512374 Fax.No: 0891-2514793	RT,UT,MT
82.	M/s. Kalva Engineers Pvt.Ltd Plot No: 17, #2-1-112 / 1 Mamatha Nagar Colony, Nagole, Hyderabad- 500 068. K.S.R.Chandra Murthy 9849005027 040 65216871 kalva@vsnl.com	UT,MT
83.	M/s. Test Well Private Limited Plot No:16, Snehitha Hills, PeranCheruvu, Ap Police Acdamy, Rajendra Nagar Mandal, RrDist, Ap. mr.nagababu ph. no:9000423888	UT,MT
84.	M/s. Engineering Inspection Logistics, H.No.-1180, Sector-8, Faridabad-121006 Haryana.	RT,UT

RATE CONTRACT 2014 – Ranipet :: Outsourcing Department
SECTION – VIII
5) LIST OF APPROVED GALVANISING VENDORS

- | | |
|----|---|
| 01 | Hari Galvanizers Private Limited
124/12,Keelmeni Road
Chinnambedu Post
Ponneri Taluk, Thiruvallur Dt PIN 601 206 |
| 02 | Kaizen Galvatech Pvt Ltd
Shed No 88/A
Sidco Industrial Estate
Thirumazhisai
Chennai PIN 602 107 |
| 03 | Jayaam Galvanizers Private Ltd
Sf-42/3,Ponneri Road
Madhavaram Village,Amoor P.O
Chennai PIN 601 204 |
| 04 | Radhakrishna Chetty
G2 Unit
Co-Op Indl Eatate
Vyasarpadi, Chennai |
| 05 | Industrial Sales&Services Galvanizing Works
3,Puliyambedu,Velappanchavadi
Poonamallee High Road
Chennai, PIN 600 077 |
| 06 | Mantek Galvanizers
D-75A Developed Plot Estate
Thuvakudi
Trichirapalli, PIN 620 015 |
| 07 | New Balaji Galvanisers
1-16 & 1-17, Electricals & Electronics Indl Estate
Thuvakudi
Trichirapalli, PIN 620 015 |

**SECTION - VIII
LIST OF APPROVED VENDORS**

6) LIST OF APPROVED HEAT TREATMENT VENDORS

S.No	Vendor Code	Area Code	Vendor Name	ADDRESS	EMAIL ID	PHONE NO
1	30332	A05	RAMAN STRLS & ALLIED INDS.	RAMAN STRLS & ALLIED INDS. No:F-1, Ancy. Indl. Estate Thiruverumbur TIRUCHIRAPALLI 620014	ramanstructurals@yahoo.com	9443302468
2	30175	A10	KATTHIRMALAI ENGINEERING WORKS	KATTHIRMALAI ENGINEERING WORKS G1 ANCILLARY INDUSTRIAL ESTATE THIRUVERUMBUR TIRUCHIRAPALLI TIRUCHIRAPALLI - 620 014 620014	katthirmalai@hotmail.com	9942984454
3	30114	A21	VANGUARD INDUSTRIES	VANGUARD INDUSTRIES D2-B, INDL ESTATE THIRUVERUMBUR TIRUCHIRAPALLI THIRVERAMBUR 620014	van30114@yahoo.co.in	9842412672
4	30265	B21	JAYARAM ENGINEERING WORKS,	JAYARAM ENGINEERING WORKS, E-15 & 16,DEVELOPED PLOTS ESTATE, THUVAKUDI, TRICHY 620015	cmrao@jayaramengg.com	98424-55045
5	30061	C34	G.K SONS ENGG ENTERPRISES PVT.LTD.,	G.K SONS ENGG ENTERPRISES PVT.LTD., 30, MANNARPURAM TIRUCHIRAPALLI TRICHY-TOWN 620020	unit3@gksons.com	9842412262

**SECTION - VIII
LIST OF APPROVED VENDORS**

6) LIST OF APPROVED HEAT TREATMENT VENDORS

S.No	Vendor Code	Area Code	Vendor Name	ADDRESS	EMAIL ID	PHONE NO
6	31321	C62	WIRE AND WIRE PRODUCTS	WIRE AND WIRE PRODUCTS NO.46/210, PUDUKKOTTAI MAIN ROAD SEMPATTU TIRUCHY 620007	wwp620007@yahoo.co.in	9444278887
7	31490	C69	DREAMZ INDUSTRY	DREAMZ INDUSTRY 149/1B, VENGANGUDI MANNACHANALLUR TALUK TIRUCHIRAPALLI 621112	dreamzindustry2012@yahoo.com	9894661983
8	31841	F06	SREE SIVA SAKTHI ENGINEERING WORKS	SREE SIVA SAKTHI ENGINEERING WORKS PLOT No.11,12 & 13, SF.No.18/1 - C AVOOR MAIN ROAD MATHUR MATHUR-PUDUKKOTTAI 622515	ssshangers@gmail.com	9842052200
9	31203	J09	M.Se INDUSTRIES	M.Se INDUSTRIES 57B, ANAMALAI AMMAN KOVIL STREET L&T BYE PASS ROAD, VELLALORE COIMBATORE 641111	msemovers@yahoo.co.in	9843347004
10	31025	J71	MANI NAGGAPPA MOTORS MADURAI P LTD.	MANI NAGGAPPA MOTORS MADURAI P LTD. SL.NO.90/3 MADURAI-MELUR MAIN ROAD, NARASINGAMPATTI, MADURAI 625122	nagauto@gmail.com	9344101699

**SECTION - VIII
LIST OF APPROVED VENDORS**

6) LIST OF APPROVED HEAT TREATMENT VENDORS

S.No	Vendor Code	Area Code	Vendor Name	ADDRESS	EMAIL ID	PHONE NO
11	30236	L78	VUJJAAY COY INDUSTRIES	VUJJAAY COY INDUSTRIES F2 / 4, SIDCO INDUSTRIAL ESTATE ARIYAMANGALAM TIRUCHIRAPPALLI 620010	vcitry@yahoo.com	9952411461
12	30761	L81	AMBIGAI ENGINEERING WORKS UNIT II	Ms. AMBIGAI ENGINEERING WORKS UNIT II SF NO. 169/1,170/1A,170/1B,170/3a2, 174/3,170/11,170/3A1, PUDUKKUDI,-TANJORE DISTRICT 613402	ambigai_engg@hotmail.com	9345986491
13	30086	M16	PIONEER ENGG INDS	PIONEER ENGG INDS NO2,CHENNAI BYPASS ROAD SUBARAMANIYABURAM TIRUCHIRAPALLI TRICHY-TOWN 620020	pioneereng_ind@yahoo.co.in	9842402255
14	30084	M27	NIRMAL ENTERPRISES	NIRMAL ENTERPRISES PUGAZH NAGAR (OPP.OIL MILL BUS STOP) TIRUCHIRAPALLI KATTUR 620019	try.nent@gmail.com	94432 11693
15	30090	M52	R.K METAL INDUSTRIES	R.K METAL INDUSTRIES 32/4, III STREET,NEHRU NAGAR KAJAMALAI MAIN TIRUCHIRAPALLI TRICHY-TOWN 620023	rkmatal2003@yahoo.com	0431-2556564

SECTION - VIII
LIST OF APPROVED VENDORS
6) LIST OF APPROVED HEAT TREATMENT VENDORS

S.No	Vendor Code	Area Code	Vendor Name	ADDRESS	EMAIL ID	PHONE NO
16	30087	M68	PUNITHA ENGG WORKS	PUNITHA ENGG WORKS SF No.286/2-A, TRICHYRAPPALLI THIRUNEDUNGULAM 620015	punithaenggtry@gmail.com	9942462023
17	30861	D03	MARIA ENGINEERING ENTERPRISES,	MARIA ENGINEERING ENTERPRISES SF.NO.22/1, TRICHY-TANJORE MAIN ROAD, ASSUR POST TRICHY 620015	mariaenggenterprises@gmail.com	9865370000

Section IX

BHEL/BAP/Ranipet ::: OS-54AA-ARC ::: PAGE: 01 / 04

List Of Standard QWI

PROCEDURE NUMBER	Rev	Effective Date	Title Of The Procedure
A. GENERAL			
PR:QA:076	00	01/10/88	Kerosene Leak Test
QCP:002 A1(RP) A1(PP)	01	01/01/95 28/01/95 28/08/01	Fabrication Of Structural Part (Fabrication Of Non Pressure Parts)
SIP:NP:06	00	15/07/96	Procedure For Visual Inspection Of Non Pressure Parts
SIP:NP:07	00	15/07/96	Welding Qualification For Structural Application
SIP:PP:22	03	10/05/03	Procedure For Surface Preparation And Painting
BAP:NDT:RP: MT:01	02	14/08/99	Procedure For Magnetic Particle Examination Of Ferric Material And Welded Components
BAP:HT:001 A1	05	11/07/96 06/07/03	Heat Treatment Schedule
BAP:NDT:RP: PT:01	02	14/08/99	Procedure For Liquid Penetrant Examination
PR:QA:500	00	16/01/93	Procedure For Allowable For Deviations For Dimensions Without Specified Tolerances
PR:QA:502	00	21/04/93	Procedure For Restarting Of Furnace In Case Of Power Failurss
PR:QA:504	00	27/05/93	Procedure For Seaworthy Packing Of Components For Export Contracts
PR:QA:505	01	14/07/93	Procedure For Storage Of Shelf Life Items Like Rust Preventive Fluids, Paints, Rubber Components, Grease, Anti Seize Compounds And Similar Components/Items
PR:QA:506	00	10/08/01	Verification (Or) Checking Of Steel Measuring Tapes Used By Subcontractors (Or) Vendors
PR:QA:507	00	05/07/93	Procedure For Localised Heat Treatment On Structural Weld Joints
PR:QA:508	02	31/03/98	Procedure For Blast Cleaning
PR:QA:509	00	04/08/93	Guide Lines For Ndt Requirement On Gas Cut Edges
PR:QA:510	00	10/06/92	Measurement Of Internal And External Key Way Dimensions
PR:QA:512	00	31/04/94	Procedure For Control Of Surface Preparation And Painting Of Fabricated Components At Sub Contractors Works
PR:QA:514	03	24/07/99	Procedure For Color Coding Of Raw Material
PR:QA:516	00	24/04/95	Product Ncr Cause Codes
PR:QA:521	00	31/08/95	Codification Of Sars
PR:QA:590 A1 A2 A3	00	10/10/02 01/01/03 05/02/03 26/04/03	Procedure For Surface Preparation And Painting For Bap Products
SQW-01	00	10/06/93	Standard Qp For Welding
B. ELECTOSTATIC PRECIPITATORS			
QCP:E:002 A1	02	03/03/00 04/01/01	Splicing Norms For Sheets, Plates And Other Structural Items
QCP: E:009	00	05/10/88	Manufacture Of Packing Frames And Angle Irons For Collecting Electrodes
QCP:E:18 A1 A2	00 00 00	30/04/92 07/07/93 2801/95	Grip Coupling
SQP:ESP:201	00	20/01/01	Pin Wheel Assy
SQP:ESP:283	00	20/06/98	Esp Supporting Structure(Column And Bracing & Long And

Section IX

BHEL/BAP/Ranipet ::: OS-54AA-ARC ::: PAGE: 02 / 04

List Of Standard QWI

A1	00	17/08/00	Transverse Roof Beams)
A2	00	04/01/01	
A3	00	23/07/02	
SQP:ESP:284 A1	00 00	20/06/98 25/01/01	Plate Formed Fabricated Components Side Panels , Casing Shell , Top Panel , Hopper Wall, Roof Panel, Funnel Assy And Its Splitters, Gd Housing Panels
SQP:ESP:285 A1	00 00	20/06/98 25/01/01	Collecting And Emitting Electrodes Suspension Frames Of Esp
SQP:ESP:286	00	20/06/98	Rapping Shaft Foundation Bolts & Lifting Holders
SQP:ESP:287 A1 A2	00 00 00	20/06/88 18/09/00 25/01/01	Inner Arm,Outerarm,Shockbar,Vertical Stay,Vertical Beam,Supporting Beam.
SQP:ESP:288 A1	00 00	20/06/98 25/01/01	Insulator Housing
SQP:ESP:289	00	20/06/98	Expansion Joint
SQP:ESP:290 A1	00 00	20/06/98 25/01/01	Screen Sheet
SQP:ESP:260 A1 A2	00 00 00	31/01/94 05/11/97 15/02/02	Guillotine Gates

C. WEG AND CHIMNEYS

QCP:W:001	00	20/07/96	Qcp For Wind Mill Structure
QCP:W:003	00	18/11/94	Qcp For Nacelle Cover Assembly
QCP:W:004	01	17/07/96	Qcp For Assembly For Nacelles Of Wind Generators(Nortex Design)
QCP:I:001 A1 A2	03	29/06/94 28/11/00 27/12/00	Qcp For Ipp Chimenys
PR:QA:518	00	27/05/95	Surface Preparation And Painting Of Weg Tower And Nacelle
PR:QA:542	00	09/03/99	Procedure For Trial Assy Of Cylindrical Steel Chimney Shells

D. GATES AND DAMPERS OF BOILER DUCTS

SIP:NP:08	00	15/07/96	Quality Requirement For Manufacturing Of Seals For Louvers, Biplane Dampers And Gates
SQP:NP:03 A1 A2	01	01/02/95 12/08/00 27/02/02	Louvers And Biplane Dampers
SQP:NP:04 A1	01	01/02/95 04/12/96	Guillotine Gates
ICL-DAM:502	00	28/02/02	Inspection Check List For Biplane Dampers

E. FANS

QP:FAN:302	00	12/01/01	Rvc Assy
QP:FAN:304	00	29/10/01	Pent House Ventilation Fan/Seal Air Fan
QP:FAN:306	01	10/06/94	Seal Air Fan
QP:FAN:317 A1 A2	04	11/08/97 22/08/98 07/12/00	Radial Fan Impellers And Conical Cover Plate
QP:FAN:323	01	11/12/94	Connecting Ring And Supporting Ring
QP:FAN:324	01	15/11/93	Bush For Servo Motor
QP:FAN:326	01	26/07/95	Ap Fan Shaft Assy
QP:FAN:327	01	28/09/96	Piston With Adjusting Disc
QP:FAN:328	01	06/07/94	An Fan Impeller
QP:FAN:329	00	22/11/93	Ap Impeller Cover Plate

Section IX

BHEL/BAP/Ranipet ::: OS-54AA-ARC ::: PAGE: 03 / 04

List Of Standard QWI

A1		13/01/94	
QP:FAN:330 A1	00	22/11/93 13/01/94	Ap Hub With Supporting Body
QP:FAN:332	01	20/06/94	Blade Shaft
QP:FAN:333 A1	00	22/11/93 13/01/94	Cylinder Assy
QP:FAN:334 A1	00	22/11/93 13/01/94	Ap Hub Disc
QP:FAN:335 A1	00	22/11/93 13/01/94	Ap Fan Bearing Cover
QP:FAN:336 A1	00	22/11/93 13/01/94	Impeller Hub And Blade Bearing Assy
QP:FAN:338 A1	00	22/11/93 13/01/94	Supporting Body
QP:FAN:342 A1	01	29/11/94 11/08/03	Spiral Casing Of Ndv, Ndzv And Ndfv Fans
QP:FAN:343 A1 A2	03	22/07/95 09/05/01 02/01/03	Damper Control Assy
QP:FAN:345 A1	00	06/07/94 19/08/97	Radial Fan Shaft Of Tube With End Piping Design
QP:FAN:346	01	31/05/95	Solid Shaft Of Radial Fans
QP:FAN:347	02	20/06/95	Impeller Of Czech Design D1 Type
QP:FAN:348	00	10/06/96	Ap Fan Hsg And Hub Front Part
QP:FAN:350	00	05/06/95	Expansion Joint For Fans
QP:FAN:352	00	13/11/95	Shaft With Brg Assy(Tube Type)
QP:FAN:353 A1	01	09/12/95 15/02/00	Control Rod And Control Slide/Control Sleeve
QP:FAN:354 A1	00	03/02/96 05/12/00	Radial Fan Rotor Asssy
QP:FAN:355	00	26/04/96	Hub With Flange
QP:FAN:356	01	10/06/96	Outlet Guide Vane Assy
QP:FAN:357	00	05/12/00	Steel Compensating Weight Of Ap Fan
QP:FAN:358	00	05/12/00	Ap Fan Lever
QP:2:4:271 A1	00	18/05/81 22/08/94	Igv Assy (Nd Type Fans)
QP:2:4:272 A1	00	18/05/81 22/08/94	Igv Assy (An Type Fans)
QP:2:4:273 A1	00	18/05/81 22/08/94	An Static Fan Parts(Kkk Design)
QP:2:4:274 A1	00	18/05/81 22/08/94	Ap Static Fan Parts(Kkk Design)
QCP:F:002 A1 A2	00	16/05/88 22/08/94 03/09/98	Ap Fan Diffuser Assy
QCP:F:007 A1	00	16/05/88 20/08/94	Ap Fan Suction Chamber
QCP:F:010 A1	00	16/05/88 18/08/94	Brg Pedestal,Base Frame For Hydraulic Coupling,Base Frame For Moyer
SQP:312	01	12/01/02	Lube Oil System And Fittng
PR:QA:302	01	03/02/03	Requirements For Balancing Mandrel
PR:QA:304	01	03/02/03	Reblading/Repair Of Axialchezck Type/An Impellers
PR:QA:305	01	03/02/03	Trail Assy Of Ndzv Spiral Casing
PR:QA:309	04	03/02/03	Recommended Balancing Speeds For Fan Components
PR:QA:314	03	03/02/03	Verification Of Performance Of Balancing Machine With Master Rotor
PR:QA:321	03	03/02/03	Balencing Of Ap Fan Shaft

Section IX			
BHEL/BAP/Ranipet ::: OS-54AA-ARC ::: PAGE: 04 / 04			
<u>List Of Standard OWI</u>			
PR:QA:323	02	03/02/03	Guidelines For Fixing Of Balancing Correction Masses
PR:QA:326	01	03/02/03	Hot Pressing Of An Impeller Blades, Root Stifners And Guide Vanes Of Ap, An Static Parts
PR:QA: 329	01	03/02/03	Assembly Of Functional Test Of Ndfv Shaft With Bearing Assy
PR:QA:333	01	03/02/03	Ensuring Specified Interference Fil Incase Of Deviation In Shaft In Tube Bore
PR:QA:341	01	03/02/03	Preservation And Packing Of Fan Rotor Assy
<u>F. AIR PREHEATERS</u>			
QCP:2:4:258 A1 A2	00	01/03/81 13/01/02 05/02/03	Cleaing Devices Of Aph
SQP:APH:104	01	27/01/03	Tubular Aph
SQP:APH:107	00	18/10/02	Heating Elements Basket Assembly
PR:QA:410	02	04/12/02	Procedure For Fabrication Of Extra Width Plates
<u>G. DESALINATION</u>			
QCP:D:001	00	15/05/97	Fabrication And Assembly Checks On And Desalination Plants
PR:QA:526	01	14/08/01	Surface Preparation And Painting Of Components & Desalination Plants

H. List Of Cross Referred Documents For Fan

Sl. No	Sqp No.	Rev No.	Cross Referred	Superseded By
01	Fan:308	02	IS 2147	IS 13947
02	Fan:310	00	IS 2147	IS 13947
03	Fan:326	01	PR:QE:017/03 PR:QA:0173/00 PR:QA:061	PR:QA:337/00 PR:QA:341/00 PR:QA:338/00
04	Fan:331	00-A1	QCP:1600111530	PR:QA:328/00
05	Fan:336	00-A1	QCP:16000111529(4) PR:QA:082/00	PR:QA:332/00 PR:QA:331/00
06	Fan:339	00-A1	QCP:F:009/00-A1	PR:QA:320/01
07	Fan:341	00-A1	PR:QE: 017/03 QCP:F:004/00 PR:QA:173/00	PR:QA:337/00 PR:QA:321/00 PR:QA:341/00
08	Fan:345	00	PR:QE:017/03 PR:QA:173/00	PR:QA:337/00 PR:QA:341/00
09	Fan:346	00	PR:QE:017/03 PR:QA:173/00	PR:QA:337/00 PR:QA:341/00
10	Fan:354	00	PR:QA:061/00	PR:QA:338/00

Note: To view the quality documents specified in the Section X, Click “Quality Documents” button available in the Main Page. Vendors can view the documents at OS department also.

 <p>An ISO Company</p>	<p>BHARAT HEAVY ELECTRICALS LIMITED (A Government of India Undertaking)</p> <p>பாரதமிருமின் நிறுவனம்</p> <p>BOILER AUXILIARIES PLANT, Indira Gandhi Industrial Complex, RANIPET- 632 406 (Tamil Nadu)</p>	<p>Ph: 04172-284030, 284158,, 241170</p> <p>Email: bsmanian@bhel.in ssvasan@bhel.in</p>
<p align="center">BHEL-BAP-OS- 54AA-ARC SECTION – XI BANK GUARANTEE (Instructions to Fill the Bank Guarantee Format to be issued by BHEL)</p>		
<p>Minimum base BG value of Rs.10.00 Lakhs should be provided by the vendor at the time of signing the contract.</p>		
<ol style="list-style-type: none"> 1. Bank Guarantee shall be issued by any one of BHEL's Bankers or any Nationalized Bank. Please refer to List of BHEL's Bankers enclosed. <ol style="list-style-type: none"> a. If it is not possible, then BG can be issued by a Scheduled Commercial Bank with the prior approval of BHEL. b. BG from Co-operative Banks is not acceptable. 2. Pre-printed BG Form of BHEL only shall be used. Should not retype the format. <ol style="list-style-type: none"> a. Only the relevant information like Supplier Name, BG Value, Contract No., Validity etc. shall be typed in the pre-printed form and executed by Bank. b. Special adhesive stamp of the required value shall be affixed on the 1st page of the Form. c. If Special Adhesive stamps are not available, then applicable stamp duty shall be paid at the Bank / Agency nominated by the concerned State Government to collect stamp duty, who" will affix their signature, date and seal in the first page of the BG Form clearly marking it as "SPECIALADHESIVE" & "STAMP DUTY". d. Stamp Duty for the BG shall be at the rate as applicable in the State where the BG is executed. e. Bank seal shall be affixed on the special adhesive stamp. 3. The executing officer of the Bank shall indicate his name, designation and power of attorney number/signing power number etc. on the BG. <ol style="list-style-type: none"> a. Any correction / overwriting on the BG shall be duly authenticated under the Seal and signature of the executing officer of the Bank. b. Each page of the BG shall be duly signed/initialed by the executing officer of the Bank and the last page is to be signed with full particulars under the seal of the Bank. c. Fax number, e-mail Address, contact person, phone number and complete postal address shall be indicated in the covering letter of the BG from Bank. 4. The validity of the BG shall cover a period of 18 months (or such other period as per purchase Order, if otherwise specified) from the last date of dispatch as per Purchase Order or actual date of last dispatch under the Purchase Order, whichever is later. 		

- a. The BG shall have a claim period of 3 months. If no separate claim period is indicated in the BG, then the validity shall be 18 months (or such other period as per Purchase Order, if otherwise specified) plus 3 months.
 - b. No clause of the BHEL BG Form shall be altered, deleted or new clauses added by the issuing Bank under any circumstances. Bank Guarantees with altered/deleted/added clauses will not be accepted by BHEL under any circumstances.
 - c. If the issuing bank wants to add any additional clauses, it shall be intimated to BHEL well in advance with exact text of clause, which shall be subject to approval by BHEL Law department. Those clauses specifically accepted by BHEL- Law department can be added in the last page of the BG form and executed by Bank.
5. Bank Guarantee shall be forwarded by issuing Bank directly to AGM(OS)/BHEL/BAP/Ranipet-632406.
- a. If it is not directly forwarded to BHEL due to unavoidable circumstance, then the issuing bank shall sent a letter directly to BHEL conforming the issue of the BG enclosing a photocopy of the original BG
 - b. The bank guarantee should not be routed through Bank along with other dispatch documents under any circumstances.
6. In case of any extension of BG the same shall be executed on non-judicial stamp paper of the required value.
- a. Only the due date and claim period shall be extended
 - b. The extension should not result in alteration of any material facts of the BG.
7. Bank Guarantees executed as per the above instruction only shall be accepted at our end. Hence kindly ensure compliance with the above instructions for yearly processing of the bills and to avoid hold up of the bills

List of Bankers from whom Bank Guarantee is to be obtained.

	Nationalised Bank	13	State Bank of Hyderabad	24	Standard Chartered Bank
1	Allahabad bank	14	Syndicate Bank	25	The Royal Bank of Scotland N.V.
2	Andhra bank	15	State Bank of Travancore	26	J P Morgan
3	Bank of Baroda	16	UCO Bank		Private bank
4	Canara Bank	17	Union Bank of India	27	Axis Bank
5	Corporation bank	18	United Bank of India	28	The Federal Bank Limited
6	Central bank	19	Vijaya Bank	29	HDFC
7	Indian Bank		Public Sector Banks	30	Kotak Mahindra Bank
8	Indian Oversea Bank	20	IDBI	31	ICICI
9	Oriental bank of Commerce		Foreign bank	32	Indusind Bank
10	Punjab National Bank	21	CITI Bank N.A	33	Yes Bank
11	Punjab & Sindh Bank	22	Deutsche Bank AG		
12	State Bank of India	23	The Hong kong and Shanghai Banking Corporation Limited		

Bank Guarantee No : Date..... Banker Name :

Bank Guarantee Value Rs.....Lakh(s)

FIRM CODE :

Please affix Rs.80/- Non Judicial
Stamp here

1. THIS DEED OF GUARANTEE made this.....day of.....20.....
by (hereinafter called the Bank) in favour of
M/s. BHARAT HEAVY ELECTRICALS LIMITED, BOILER AUXILIARIES PLANT,
RANIPET-632 406 having its Registered Head office at BHEL HOUSE, SIRI FORT, NEW DELHI,
Pin - 110 049.
2. WHEREAS M/s. BHARAT HEAVY ELECTRICALS LIMITED, hereinafter called the "COMPANY"
have placed Purchase Orders / Work Orders which are pending as on date and also future
Purchase Orders / Work Orders to be placed by the company upto the expiry of this Guarantee
(hereinafter called the "CONTRACT") for machining fabrication supply of pressure and non-
pressure parts with
..... (hereinafter called the
CONTRACTOR/SUPPLIER) and the said machining / fabrication / supply of pressure and non-
pressure parts shall be made from the supply of raw materials and components by the company
to the Contractor / Supplier in pursuance of the Contract(s) already placed but pending execution
as on date and the Contract(s) to be placed from time to time by the company on the contractor/
supplier.
3. AND WHEREAS one of the conditions for placing such Contract(s) is that contractor / supplier
shall provide the company with a Bank Guarantee to the extent of Rs.....
(Rupees.....) as a security for the raw
materials and components supplied and to be supplied in pursuance of the contract(s) already
placed and pending as on date/and the contract(s) to be placed from time to time upto the
expiry of this Guarantee and also for the satisfactory performance and completion of work/supply
and the terms and conditions of the said contract.
4. AND WHEREAS the contractor/supplier have approached the Bank and at their request and in
consideration of arrangements arrived at between the said contractor/supplier and the said
Bank. We, the Bank have agreed to give such guarantee as hereinafter mentioned in favour of
the aforesaid company.

Sign & Seal of issuing Bank

Bank Guarantee Value Rs.....Lakh(s)

5. NOW, THEREFORE, these present witness that we, the Bank by the hand of Branch Manager its lawfully and duly constituted attorney, do hereby undertake irrevocably and unconditionally to pay without demur to the aforesaid company a sum of Rs..... (Rupees.....) on demand being made by the said company and to keep the said company indemnified to the extent of Rs..... (Rupees.....) by virtue of this guarantee against any loss/damage caused to/suffered by the said company, by reason of any breach by the aforesaid contractor/supplier of any of the terms and conditions, stipulations or undertakings or any one of them contained in the said contract(s) and the tender documents if any attached there to and for the payment of any money payable by the said Contractor/Supplier to the said company under the terms and conditions of the said contract(s) (the decision regarding the breach, loss, damage or payment due being solely in the discretion of said company). We further undertake to pay the aforesaid amount in lumpsum on demand without demur or such part thereof as the company may demand from time to time, irrespective of the fact whether the said Contractor/Supplier admits or denies such claim or questions its correctness in any court, Tribunal Arbitrations proceedings or before any authority. The liability or obligation of Bank under this guarantee would not wait till the disputes have been decided by any Court or Tribunal or in the Arbitration proceedings or by any other authority. It shall not be necessary for the said company to proceed against the Contractor / Supplier before proceeding against the Bank and its Guarantee herein contained shall be enforceable notwithstanding any security, which the said company may have obtained or obtain from the Contractor / Supplier. Further any payment made by the Bank to the company under this guarantee shall be deemed to have been duly and lawfully made.
6. The liability under this guarantee is a continuing one covering all contracts, already placed and pending as on date to be placed upto the expiry of this Guarantee and should any loss or damage occur on account of the breach of the terms and conditions of the said Contract(s) by the Contractor/Supplier or should any surplus raw materials and components become due to the Company under Contract(s) and remain undelivered to company, the Bank shall indemnify the Company for loss/damage for the value of raw materials and components, to an extent of Rs..... (Rupees.....) and this is without prejudice to any other remedies which may be otherwise available to the company against the Contractor/Supplier by way of deduction from any sum due or any sum which at any time hereafter become due from the Contractor/Supplier under this or any other contracts.

Sign & Seal of issuing Bank

Bank Guarantee Value Rs.....Lakh(s)

7. THE AFORESAID Guarantee will remain in force and the Bank shall be liable under the same irrespective of any concession or time being granted by the said company to the Contractor/Supplier in or for fulfilling the said contract(s) between Contractor/Supplier and the Company and the guarantee will remain in full force irrespective of any change of terms, conditions or stipulations or any variations in the terms of the said Contractor(s) and irrespective of whether notice of such change and/or variation is give to us or not and claim to receive such notice of any change and/or variation is given to us or not and claim to receive such notice of any change and /or variation of the terms and /or conditions of the said Contract(s) is hereby specially waived by us. Further, we shall not be released from this guarantee by any forbearance or the exercise or non exercise of any of the power or rights under the said contract(s) by the said company against the Contractor/Supplier irrespective of whether, notice of such forbearance enforcement or non enforcement of any powers or rights, modifications or changes made in the said contract(s) or concession shown to Contractor/Supplier by the Company is given to us or not.
8. THE GUARANTEE herein contained shall not be determined or affected by the liquidation or winding up or insolvency of or change in the constitution of the Contractor/Supplier and shall in all respects and for all purposes be binding and operative until all payments of all money due or that may hereafter become due to the said company are settled irrespective of any liability or obligation of the Contractor/Supplier under the said Contract(s).
9. A REFERENCE to this Bank Guarantee in the contract(s) placed already and pending as on date and to be placed upto the expiry of this Guarantee shall be sufficient to bind the Bank in respect of their liability under this Bank Guarantee and this Bank Guarantee shall be read as an integral part of the contract(s) already placed but pending as on date and to be placed upto the expiry of this Guarantee.
10. WE, THE BANK, further agree that the Guarantee herein contained shall remain in full force and effect during the period that would be taken for the performance of the said contract(s) and that it shall continue to be enforceable till all the dues of the company under or by virtue of the said contract(s) have been fully paid and its claims satisfied that the terms and conditions of the contract(s) have been fully and properly carried out by the said Contractor/Supplier and accordingly discharge the Guarantee, subject, however to the condition that the company shall have no rights under this guarantee unless a claim or demand in writing in respect of this guarantee has been preferred by the company with the Bank on or before/...../..... (including a claim period of 3 months). For the purpose of this clause any letter making the demand on the Bank by M/s.BHEL despatched by R.P.A.D. or by telegram or by FAX or by any electronic media addressed to the above mentioned address of the Bank shall be deemed to

Sign & Seal of issuing Bank

Bank Guarantee Value Rs.....Lakh(s)

be the claim/demand in writing referred to above irrespective of the fact as to whether or when the said letter reached the Bank, as also any letter containing the said demand or claim is lodged with the Bank personally.

11. Any CLAIM OR DISPUTE arising under the terms of this document shall only be enforced or settled in the Courts at Ranipet, Vellore District only.
12. THE BANK undertake not to revoke this Guarantee during the currency except with the previous consent of the Company in writing.
13. THE BANK declares that it has powers to issue this Guarantee and the undersigned has full powers to do so on its behalf under the power granted to him by the proper authorities of the Bank.
14. Notwithstanding anything contained herein before, our liability under this guarantee shall be limited to a sum of Rs..... and stand completely extinguished and discharged if no demand or claim is made upon us in writing on or before/...../..... (including a claim period of 3 months).

DATE THIS..... DAY OF20

Seal of the Bank

Signature of the Bank Manager