

PROFORMA OF BANK GUARANTEE (in lieu of EARNEST MONEY)
(On non-Judicial paper of appropriate value)
(Para 4.7.6 of Works Accounts Manual)

Bank Guarantee No.....

Date.....

To
(Employer's Name and Address)

.....

Dear Sirs,

In accordance with the terms and conditions of Invitation for Bids/Notice Inviting Tender No.....¹ (Tender Conditions), M/s.² having its registered office at³ (hereinafter referred to as the 'Tenderer'), is submitting its bid for the work of.....⁴ invited by Bharat Heavy Electricals Limited (hereinafter referred to as the 'Employer' which expression shall unless repugnant to the context or meaning thereof, include its successors and permitted assigns) incorporated under the Companies Act, 1956 and having its registered office at *BHEL House, Siri Fort, Asiad, New Delhi – 110049* through its unit at *Bharat Heavy Electricals Limited, Power Sector Southern Region, 690, Anna Salai, Nandanam, Chennai 600035*

The Tender Conditions provide that the Tenderer shall pay a sum of Rs⁵ as Earnest Money Deposit in the form therein mentioned. The form of payment of Earnest Money Deposit includes Bank Guarantee executed by a Scheduled Bank.

In lieu of the stipulations contained in the aforesaid Tender Conditions that an irrevocable and unconditional Bank Guarantee against Earnest Money Deposit for an amount of⁶ is required to be submitted by the Tenderer as a condition precedent for participation in the said Tender and the Tenderer having approached us for giving the said Guarantee,

we, the(Name & address of the Bank)
..... having our Head Office at
.....(hereinafter referred to as the Bank) being the Guarantor under this Guarantee, hereby irrevocably and unconditionally undertake to forthwith and immediately pay to the Employer without any demur, merely on your first demand any sum or sums of Rs.....⁶ (in words Rupees.....) without any reservation, protest, and recourse and without the beneficiary needing to prove or demonstrate reasons for its such demand.

Any such demand made on the Bank shall be conclusive as regards the amount due and payable by the Bank under this guarantee. However, our liability under this guarantee shall be restricted to an amount not exceeding Rs.⁶

We undertake to pay to the Employer any money so demanded notwithstanding any dispute or disputes raised by the Tenderer in any suit or proceeding pending before any Court or Tribunal, Arbitrator or any other authority, our liability under this present being absolute and unequivocal.

The payment so made by us under this Guarantee shall be a valid discharge of our liability for payment hereunder and the Tenderer shall have no claim against us for making such payment.

We Bank further agree that the Employer shall have the fullest liberty without our consent and without affecting in any manner our obligations hereunder to vary any of the terms and conditions of the said Tender or to extend the time of submission of from time to time or to postpone for any time or from time to time any of the powers exercisable by the Employer against the said

Tenderer and we shall not be relieved from our liability by reason of any such variation, or extension being granted to the said Tenderer or for any forbearance, act or omission on the part of the Employer or any indulgence by the Employer to the said Tenderer or by any such matter or thing whatsoever which under the law relating to sureties would but for this provision have effect of so relieving us.

The Bank also agrees that the Employer at its option shall be entitled to enforce this Guarantee against the Bank as a principal debtor, in the first instance without proceeding against the Tenderer and notwithstanding any security or other guarantee that the Employer may have in relation to the Tenderer's liabilities.

This Guarantee shall be irrevocable and shall remain in force upto and including.....⁷ and shall be extended from time to time for such period as may be desired by the Employer.

This Guarantee shall not be determined or affected by liquidation or winding up, dissolution or change of constitution or insolvency of the Tenderer but shall in all respects and for all purposes be binding and operative until payment of all money payable to the Employer in terms hereof. However, unless a demand or claim under this Guarantee is made on us in writing on or before the⁸ we shall be discharged from all liabilities under this Guarantee.

We, Bank lastly undertake not to revoke this guarantee during its currency except with the previous consent of the Employer in writing.

Notwithstanding anything to the contrary contained hereinabove:

- a) The liability of the Bank under this Guarantee shall not exceed.....⁶
- b) This Guarantee shall be valid up to⁷
- c) Unless the Bank is served a written claim or demand on or before _____⁸ all rights under this guarantee shall be forfeited and the Bank shall be relieved and discharged from all liabilities under this guarantee irrespective of whether or not the original bank guarantee is returned to the Bank

We, _____ Bank, have power to issue this Guarantee under law and the undersigned as a duly authorized person has full powers to sign this Guarantee on behalf of the Bank.

For and on behalf of
(Name of the Bank)

(Signature of Authorised signatory)

Date.....

Place of Issue.....

- ¹ Details of the Invitation to Bid/Notice Inviting Tender (Tender Ref. No. Eg. - BHEL PSSR SCT XXXX)
- ² Name of Tenderer
- ³ REGISTERED Office Address of the Tenderer
- ⁴ Details of the Work i.e Tender Description
- ⁵ EMD Amount as mentioned in Notice Inviting Tender
- ⁶ BG Amount in words and Figures (BG Amount shall be Minimum of EMD amount less Rs. 2 Lakhs)
- ⁷ Validity Date
- ⁸ Date of Expiry of Claim Period (Claim Period shall be minimum of 3 Months after the validity date of Bank Guarantee)

Note:

- 1. The BG should be on Non-Judicial Stamp paper/e-stamp paper of appropriate value as per Stamp Act prevailing in the State(s) where the BG is submitted or is to be acted upon or the rate prevailing in the State where the BG was executed, whichever is higher. The Stamp Paper/e-stamp paper shall be purchased in the name of Vendor/Contractor/Supplier /Bank issuing the guarantee.
- 2. In Case of Bank Guarantees submitted by Foreign Vendors-

- a. From Nationalized/Public Sector / Private Sector/ Foreign Banks (BG issued by Branches in India) can be accepted subject to the condition that the Bank Guarantee should be enforceable in the town/city or at nearest branch where the Unit is located i.e. Demand can be presented at the Branch located in the town/city or at nearest branch where the Unit is located.
- b. From Foreign Banks (wherein Foreign Vendors intend to provide BG from local branch of the Vendor Country's Bank)
 - b.1 In such cases, in the Tender Enquiry/ Contract itself, it may be clearly specified that Bank Guarantee issued by any of the Consortium Banks only will be accepted by BHEL. As such, Foreign Vendor needs to make necessary arrangements for issuance of Counter- Guarantee by Foreign Bank in favour of the Indian Bank's (BHEL's Consortium Bank) branch in India. It is advisable that all charges for issuance of Bank Guarantee/ counter- Guarantee should be borne by the Foreign Vendor. The tender stipulation should clearly specify these requirements.
 - b.2 In case, Foreign Vendors intend to provide BG from Overseas Branch of our Consortium Bank (e.g. if a BG is to be issued by SBI Frankfurt), the same is acceptable. However, the procedure at sl.no. b.1 will required to be followed.
 - b.3 The BG issued may preferably be subject to Uniform Rules for Demand Guarantees (URDG) 758 (as amended from time to time).

PROFORMA OF BANK GUARANTEE (in lieu of SECURITY DEPOSIT)
 (On non-Judicial paper of appropriate value)
 (Para 4.7.6 of Works Accounts Manual)

Bank Guarantee No.....
 Date.....

To
 (Employer's Name and Address)

In consideration of Bharat Heavy Electricals Limited (hereinafter referred to as the 'Employer' which expression shall unless repugnant to the context or meaning thereof, include its successors and permitted assigns) incorporated under the Companies Act, 1956 and having its registered office at *BHEL House, Siri Fort, Asiad, New Delhi – 110049* through its unit at *Bharat Heavy Electricals Limited, Power Sector Southern Region, 690, Anna Salai, Nandanam, Chennai 600035* having agreed to exempt _____¹ (Name of the Vendor / Contractor / Supplier) with its registered office at _____² (hereinafter called the said "Contractor" which term includes supplier), from demand under the terms and conditions of the Contract arising vide Letter of Intent (LOI) reference No. _____ dated _____³ valued at Rs. _____⁴ (Rupees _____ only)⁴ (hereinafter called the said Contract), of Security Deposit for the due fulfilment by the said Contractor of the terms and conditions contained in the said Contract, on production of a Bank Guarantee for Rs. _____⁵ (Rupees _____ only),

We, the(Name & address of the Bank)
 having our Head Office at
(hereinafter referred to as the Bank), at the request of
 _____ [Contractor(s)], being the Guarantor under this Guarantee, do hereby irrevocably and unconditionally undertake to forthwith and immediately pay to the Employer, an amount not exceeding Rs. _____ without any demur, immediately on demand from the Employer and without any reservation, protest, and recourse and without the Employer needing to prove or demonstrate reasons for its such demand

Any such demand made on the bank, shall be conclusive as regards the amount due and payable by the Bank under this guarantee. However, our liability under this guarantee shall be restricted to an amount not exceeding Rs. _____⁵.

We undertake to pay to the Employer any money so demanded notwithstanding any dispute or disputes raised by the Contractor(s) in any suit or proceeding pending before any Court or Tribunal or Arbitrator or any other authority, our liability under this present being absolute and unequivocal.

The payment so made by us under this guarantee shall be a valid discharge of our liability for payment hereunder and the Contractor(s) shall have no claim against us for making such payment.

We, further agree that the guarantee herein contained shall remain in full force and effect during the period that would be taken for the performance of the said Contract and that it shall continue to be enforceable till all the dues of the Employer under or by virtue of the said Contract have been fully paid and its claims satisfied & the Employer certifies that the terms and conditions of the said Contract have been fully and properly carried out by the said contractor(s) or acceptance of the final bill or discharge of this guarantee by the Employer, whichever is earlier. This guarantee shall initially remain in force upto and including _____⁶ and shall be extended from time to time for such period as may

be desired by the Employer. Unless a demand or claim under this guarantee is made on us in writing on or before the _____⁷, we shall be discharged from all the liability under this guarantee thereafter.

We, _____(indicate the name of the Bank) further agree with the Employer that the Employer shall have the fullest liberty without our consent and without affecting in any manner our obligations hereunder to vary any of the terms and conditions of the said Contract or to extend time of performance by the said contractor(s) from time to time or to postpone for any time or from time to time any of the powers exercisable by the Employer against the said contractor(s) and to forbear or enforce any of the terms and conditions relating to the said Contract and we shall not be relieved from our liability by any reason of any such variation or extension being granted to the said contractor(s) or for any forbearance, act or omission on the part of the Employer or any indulgence by the Employer to the said contractor(s) or by any such matter or thing whatsoever which under the law relating to sureties would but for this provision have effect of so relieving us.

The Bank also agrees that the Employer at its option shall be entitled to enforce this Guarantee against the Bank as a principal debtor, in the first instance without proceeding against the Contractor and notwithstanding any security or other guarantee that the Employer may have in relation to the Contractor's liabilities.

This Guarantee shall not be determined or affected by liquidation or winding up, dissolution or change of constitution or insolvency of the Contractor but shall in all respects and for all purposes be binding and operative until payment of all money payable to the Employer in terms thereof. This guarantee will not be discharged due to the change in the constitution of the Bank or the Contractor(s).

We, BANK lastly undertake not to revoke this guarantee during its currency except with the previous consent of the Employer in writing.
Notwithstanding anything to the contrary contained hereinabove:

- a) The liability of the Bank under this Guarantee shall not exceed.....⁵
- b) This Guarantee shall be valid up to⁶
- c) Unless the Bank is served a written claim or demand on or before _____⁷ all rights under this guarantee shall be forfeited and the Bank shall be relieved and discharged from all liabilities under this guarantee irrespective of whether or not the original bank guarantee is returned to the Bank.

We, _____ Bank, have power to issue this Guarantee under law and the undersigned as a duly authorized person has full powers to sign this Guarantee on behalf of the Bank.

Date _____ Day of _____ for _____ (indicate the name of the Bank)

(Signature of Authorised signatory)

¹ NAME OF VENDOR /CONTRACTOR / SUPPLIER
² REGISTERED OFFICE ADDRESS OF THE VENDOR /CONTRACTOR / SUPPLIER.
³ LETTER OF INTENT(LOI) REFERENCE NO. WITH DATE
⁴ CONTRACT VALUE (AS MENTIONED IN LOI)
⁵ BG AMOUNT IN FIGURES AND WORDS
⁶ VALIDITY DATE
⁷ DATE OF EXPIRY OF CLAIM PERIOD (CLAIM PERIOD SHALL BE MINIMUM OF 3 MONTHS AFTER VALIDITY DATE)

Note:

1. The BG should be on Non-Judicial Stamp paper/e-stamp paper of appropriate value as per Stamp Act prevailing in the State(s) where the BG is submitted or is to be acted upon or the rate prevailing in the State where the BG was executed, whichever is higher. The Stamp Paper/e-stamp paper shall be purchased in the name of Vendor/Contractor/Supplier /Bank issuing the guarantee.
2. In Case of Bank Guarantees submitted by Foreign Vendors-
 - a. From Nationalized/Public Sector / Private Sector/ Foreign Banks (BG issued by Branches in India) can be accepted subject to the condition that the Bank Guarantee should be enforceable in the town/city or at nearest branch where the Unit is located i.e. Demand can be presented at the Branch located in the town/city or at nearest branch where the Unit is located.
 - b. From Foreign Banks (wherein Foreign Vendors intend to provide BG from local branch of the Vendor Country's Bank)
 - b.1 In such cases, in the Tender Enquiry/ Contract itself, it may be clearly specified that Bank Guarantee issued by any of the Consortium Banks only will be accepted by BHEL. As such, Foreign Vendor needs to make necessary arrangements for issuance of Counter- Guarantee by Foreign Bank in favour of the Indian Bank's (BHEL's Consortium Bank) branch in India. It is advisable that all charges for issuance of Bank Guarantee/ counter- Guarantee should be borne by the Foreign Vendor. The tender stipulation should clearly specify these requirements.
 - b.2 In case, Foreign Vendors intend to provide BG from Overseas Branch of our Consortium Bank (e.g. if a BG is to be issued by SBI Frankfurt), the same is acceptable. However, the procedure at sl.no. b.1 will required to be followed.
 - b.3 The BG issued may preferably be subject to Uniform Rules for Demand Guarantees (URDG) 758 (as amended from time to time).

INTEGRITY PACT

Between

Bharat Heavy Electricals Ltd. (BHEL), a company registered under the Companies Act 1956 and having its registered office at "BHEL House", Siri Fort, New Delhi - 110049 (India) hereinafter referred to as "The Principal", which expression unless repugnant to the context or meaning hereof shall include its successors or assigns of the ONE PART

and

_____, (description of the party along with address), hereinafter referred to as "The Bidder/ Contractor" which expression unless repugnant to the context or meaning hereof shall include its successors or assigns of the OTHER PART

Preamble

The Principal intends to award, under laid-down organizational procedures, contract/s for BHEL: PSSR: SCT: 1860 - Civil, Structural and Architectural works in Foundation (pile cap & open foundation), Trenches, RCC channel & Superstructure of CWPH, Feed pool & Channel at Units 1 & 2 of 2 X 660 MW Ennore SEZ STPP (on the ash dyke of NCTPS), Thiruvallur District, Tamilnadu. The Principal values full compliance with all relevant laws of the land, rules and regulations, and the principles of economic use of resources, and of fairness and transparency in its relations with its Bidder(s)/ Contractor(s).

In order to achieve these goals, the Principal will appoint Independent External Monitor(s), who will monitor the tender process and the execution of the contract for compliance with the principles mentioned above.

Section 1- Commitments of the Principal

- 1.1 The Principal commits itself to take all measures necessary to prevent corruption and to observe the following principles:-
- 1.1.1 No employee of the Principal, personally or through family members, will in connection with the tender for, or the execution of a contract, demand, take a promise for or accept, for self or third person, any material or immaterial benefit which the person is not legally entitled to.
- 1.1.2 The Principal will, during the tender process treat all Bidder(s) with equity and reason. The Principal will in particular, before and during the tender process, provide to all Bidder(s) the same information and will not provide to any Bidder(s) confidential/ additional information through which the Bidder(s) could obtain an advantage in relation to the tender process or the contract execution.
- 1.1.3 The Principal will exclude from the process all known prejudiced persons.
- 1.2 If the Principal obtains information on the conduct of any of its employees which is a penal offence under the Indian Penal Code 1860 and Prevention of Corruption Act 1988 or any other statutory penal enactment, or if there be a substantive suspicion in this regard, the Principal will inform its Vigilance Office and in addition can initiate disciplinary actions.

Section 2 - Commitments of the Bidder(s)/ Contractor(s)

- 2.1 The Bidder(s)/ Contractor(s) commit himself to take all measures necessary to prevent corruption. He commits himself to observe the following principles during his participation in the tender process and during the contract execution.
- 2.1.1 The Bidder(s)/ Contractor(s) will not, directly or through any other person or firm, offer, promise or give to the Principal or to any of the Principal's employees involved in the tender process or the execution of the contract or to any third person any material, immaterial or any other benefit which he/ she is not legally entitled to, in order to obtain in exchange any advantage of any kind whatsoever during the tender process or during the execution of the contract.
- 2.1.2 The Bidder(s)/ Contractor(s) will not enter with other Bidder(s) into any illegal or undisclosed agreement or understanding, whether formal or informal. This applies in particular to prices, specifications, certifications, subsidiary contracts, submission or non-submission of bids or any other actions to restrict competitiveness or to introduce cartelization in the bidding process.
- 2.1.3 The Bidder(s)/ Contractor(s) will not commit any penal offence under the relevant Indian Penal Code (IPC) and Prevention of Corruption Act; further the Bidder(s)/ Contractor(s) will not use improperly, for purposes of competition or personal gain, or pass on to others, any information or document provided by the Principal as part of the business relationship, regarding plans, technical proposals and business details, including information contained or transmitted electronically.
- 2.1.4 Foreign Bidder(s)/ Contractor(s) shall disclose the name and address of agents and representatives in India and Indian Bidder(s)/ Contractor(s) to disclose their foreign principals or associates. The Bidder(s)/ Contractor(s) will, when presenting his bid, disclose any and all payments he has made, and is committed to or intends to make to agents, brokers or any other intermediaries in connection with the award of the contract.
- 2.2 The Bidder(s)/ Contractor(s) will not instigate third persons to commit offences outlined above or be an accessory to such offences.
- 2.3 The Bidder(s)/ Contractor(s) shall not approach the Courts while representing the matters to IEMs and will await their decision in the matter.

Section 3 - Disqualification from tender process and exclusion from future contracts

If the Bidder(s)/ Contractor(s), before award or during execution has committed a transgression through a violation of Section 2 above, or acts in any other manner such as to put his reliability or credibility in question, the Principal is entitled to disqualify the Bidder(s)/ Contractor(s) from the tender process or take action as per the separate "Guidelines on Banning of Business dealings with Suppliers/ Contractors", framed by the Principal.

Section 4 - Compensation for Damages

- 4.1 If the Principal has disqualified the Bidder from the tender process prior to the award according to Section 3, the Principal is entitled to demand and recover the damages equivalent Earnest Money Deposit/ Bid Security.

- 4.2 If the Principal has terminated the contract according to Section 3, or if the Principal is entitled to terminate the contract according to section 3, the Principal shall be entitled to demand and recover from the Contractor liquidated damages equivalent to 5% of the contract value or the amount equivalent to Security Deposit/ Performance Bank Guarantee, whichever is higher.

Section 5 - Previous Transgression

- 5.1 The Bidder declares that no previous transgressions occurred in the last 3 years with any other company in any country conforming to the anti-corruption approach or with any other Public Sector Enterprise in India that could justify his exclusion from the tender process.
- 5.2 If the Bidder makes incorrect statement on this subject, he can be disqualified from the tender process or the contract, if already awarded, can be terminated for such reason.

Section 6 - Equal treatment of all Bidders/ Contractors / Sub-contractors

- 6.1 The Principal will enter into agreements with identical conditions as this one with all Bidders and Contractors. In case of sub-contracting, the Principal contractor shall be responsible for the adoption of IP by his sub-contractors and shall continue to remain responsible for any default by his sub-contractors.
- 6.2 The Principal will disqualify from the tender process all bidders who do not sign this pact or violate its provisions.

Section 7 - Criminal Charges against violating Bidders/ Contractors /Subcontractors

If the Principal obtains knowledge of conduct of a Bidder, Contractor or Subcontractor, or of an employee or a representative or an associate of a Bidder, Contractor or Subcontractor which constitutes corruption, or if the Principal has substantive suspicion in this regard, the Principal will inform the Vigilance Office.

Section 8 -Independent External Monitor(s)

- 8.1 The Principal appoints competent and credible Independent External Monitor for this Pact. The task of the Monitor is to review independently and objectively, whether and to what extent the parties comply with the obligations under this agreement.
- 8.2 The Monitor is not subject to instructions by the representatives of the parties and performs his functions neutrally and independently. He reports to the CMD, BHEL.
- 8.3 The Bidder(s)/ Contractor(s) accepts that the Monitor has the right to access without restriction to all contract documentation of the Principal including that provided by the Bidder(s)/ Contractor(s). The Bidder(s)/ Contractor(s) will grant the monitor, upon his request and demonstration of a valid interest, unrestricted and unconditional access to his contract documentation. The same is applicable to Sub-contractor(s). The Monitor is under contractual obligation to treat the information and documents of the Bidder(s)/ Contractor(s) / Sub-contractor(s) with confidentiality in line with Non- disclosure agreement.
- 8.4 The Principal will provide to the Monitor sufficient information about all meetings among the parties related to the contract provided such meetings could have an impact on the contractual relations between the Principal and the Contractor. The parties offer to the Monitor the option to participate in such meetings.

- 8.5 The role of IEMs is advisory, would not be legally binding and it is restricted to resolving issues raised by an intending bidder regarding any aspect of the tender which allegedly restricts competition or bias towards some bidders. At the same time, it must be understood that IEMs are not consultants to the Management. Their role is independent in nature and the advice once tendered would not be subject to review at the request of the organization.
- 8.6 For ensuring the desired transparency and objectivity in dealing with the complaints arising out of any tendering process, the matter should be examined by the full panel of IEMs jointly as far as possible, who would look into the records, conduct an investigation, and submit their joint recommendations to the Management.
- 8.7 The IEMs would examine all complaints received by them and give their recommendations/ views to CMD, BHEL, at the earliest. They may also send their report directly to the CVO and the Commission, in case of suspicion of serious irregularities requiring legal/ administrative action. IEMs will tender their advice on the complaints within 10 days as far as possible.
- 8.8 The CMD, BHEL shall decide the compensation to be paid to the Monitor and its terms and conditions.
- 8.9 IEM should examine the process integrity, they are not expected to concern themselves with fixing of responsibility of officers. Complaints alleging mala fide on the part of any officer of the organization should be looked into by the CVO of the concerned organisation.
- 8.10 If the Monitor has reported to the CMD, BHEL, a substantiated suspicion of an offence under relevant Indian Penal Code/ Prevention of Corruption Act, and the CMD, BHEL has not, within reasonable time, taken visible action to proceed against such offence or reported it to the Vigilance Office, the Monitor may also transmit this information directly to the Central Vigilance Commissioner, Government of India.
- 8.11 The number of Independent External Monitor(s) shall be decided by the CMD, BHEL.
- 8.12 The word 'Monitor' would include both singular and plural.

Section 9 - Pact Duration

- 9.1 This Pact shall be operative from the date IP is signed by both the parties till the final completion of contract for successful bidder and for all other bidders 6 months after the contract has been awarded. Issues like warranty / guarantee etc. should be outside the purview of IEMs.
- 9.2 If any claim is made/ lodged during currency of IP, the same shall be binding and continue to be valid despite the lapse of this pact as specified above, unless it is discharged/ determined by the CMD, BHEL.

Section 10 - Other Provisions

- 10.1 This agreement is subject to Indian Laws and jurisdiction shall be registered office of the Principal, i.e. New Delhi.
- 10.2 Changes and supplements as well as termination notices need to be made in writing. Side agreements have not been made.

- 10.3 If the Contractor is a partnership or a consortium, this agreement must be signed by all partners or consortium members.
- 10.4 Should one or several provisions of this agreement turn out to be invalid, the remainder of this agreement remains valid. In this case, the parties will strive to come to an agreement to their original intentions.
- 10.5 Only those bidders / contractors who have entered into this agreement with the Principal would be competent to participate in the bidding. In other words, entering into this agreement would be a preliminary qualification.



21/09/2019

For & On behalf of the Principal

For & On behalf of the Bidder/

Contractor

संदीपन बिस्वास

SANDIPAN BISWAS

अपर महापबंधक - उप संविदा एवं क्रय
Addl. General Manager - Sub Contracting & Purchase

Bharat Heavy Electricals Limited

Place **Power Sector - Southern Region**

690, Anna Salai, Nandanam,

Date-----**Chennai- 600 035.**

(Office Seal)

Witness: _____

Witness: _____

(Name & Address) _____

(Name & Address) _____

PROCEDURE FOR CONDUCT OF CONCILIATION PROCEEDINGS

1. The proceedings of Conciliation shall broadly be governed by Part-III of the Arbitration and Conciliation Act 1996 or any statutory modification thereof and as provided herein:
2. The party desirous of resorting to Conciliation shall send an invitation/notice in writing to the other party to conciliate specifying all points of Disputes with details of the amount claimed. The party concerned shall not raise any new issue thereafter. Parties shall also not claim any interest on claims/counter-claims from the date of notice invoking Conciliation till the conclusion of the Conciliation proceedings. If BHEL is to initiate Conciliation, then, the invitation to Conciliate shall be extended to the concerned Stakeholder in **Format 7** hereto. Where the stakeholder is to initiate the Conciliation, the notice for initiation of Conciliation shall be sent in **Format-8** hereto.
3. The party receiving the invitation/notice for Conciliation shall within 30 days of receipt of the notice of Conciliation intimate its consent for Conciliation along with its counter-claims, if any.
4. The Conciliation in a matter involving claim or counter-claim (whichever is higher) up to Rs 5 crores shall be carried out by sole Conciliator nominated by BHEL while in a matter involving claim or counter-claim (whichever is higher) of more than Rs 5 crores Conciliation shall be carried out by 3 Conciliators nominated by BHEL. The appointment of Conciliator(s) shall be completed and communicated by the concerned Department/Group of BHEL Unit/Division/Region/Business Group to the other party and the Conciliator(s) within 30 days from the date of acceptance of the invitation to conciliate by the concerned party in the **Format-9**. The details of the Claim, and counter-claim, if any, shall be intimated to the Conciliator(s) simultaneously in **Format-5**.
5. The Parties shall be represented by only their duly authorized in-house executives/officers and neither Party shall be represented by a Lawyer.
6. The first meeting of the IEC shall be convened by the IEC by sending appropriate communication/notice to both the parties as soon as possible but not later than 30 days from the date of his/their appointment. The hearings in the Conciliation proceeding shall ordinarily be concluded within two (2) months and, in exceptional cases where parties have expressed willingness to settle the matter or there exists possibility of settlement in the matter, the proceedings may be extended by the IEC by a maximum of further 2 months with the consent of the Parties subject to cogent reasons being recorded in writing.

- 7.** The IEC shall thereafter formulate recommendations for settlement of the Disputes supported by reasons at the earliest but in any case within 15 days from the date of conclusion of the last hearing. The recommendations so formulated along with the reasons shall be furnished by the IEC to both the Parties at the earliest but in any case within 1 month from the date of conclusion of the last hearing.
- 8.** Response/modifications/suggestions of the Parties on the recommendations of the IEC are to be submitted to the IEC within time limit stipulated by the IEC but not more than 15 days from the date of receipt of the recommendations from the IEC.
- 9.** In the event, upon consideration, further review of the recommendations is considered necessary, whether by BHEL or by the other Party, then, the matter can be remitted back to the IEC with request to reconsider the same in light of the issues projected by either/both the Parties and to submit its recommendations thereon within the following 15 days from the date of remitting of the case by either of the Parties.
- 10.** Upon the recommendations by the Parties, with or without modifications, as considered necessary, the IEC shall be called upon to draw up the Draft Settlement Agreement in terms of the recommendations.
- 11.** When a consensus can be arrived at between the parties only in regard to any one or some of the issues referred for Conciliation the draft Settlement Agreement shall be accordingly formulated in regard to the said Issue(s), and the said Settlement Agreement, if signed, by the parties, shall be valid only for the said issues. As regards the balance issues not settled, the parties may seek to resolve them further as per terms and conditions provided in the contract.
- 12.** In case no settlement can be reached between the parties, the IEC shall by a written declaration, pronounce that the Conciliation between the parties has failed and is accordingly terminated.
- 13.** Unless the Conciliation proceedings are terminated in terms of para 22 (b), (c) & (d) herein below, the IEC shall forward his/its recommendations as to possible terms of settlement within one (1) month from the date of last hearing. The date of first hearing of Conciliation shall be the starting date for calculating the period of 2 months.
- 14.** In case of 3 members IEC, 2 members of IEC present will constitute a valid quorum for IEC and meeting can take place to proceed in the matter after

seeking consent from the member who is not available. If necessary, videoconferencing may be arranged for facilitating participation of the members. However, the IEC recommendations will be signed by all members. Where there is more than one (1) Conciliator, as a general rule they shall act jointly. In the event of differences between the Members of IEC, the decision/recommendations of the majority of the Members of IEC shall prevail and be construed as the recommendation of the IEC.

- 15.** The Draft Settlement Agreement prepared by the IEC in terms of the consensus arrived at during the Conciliation proceedings between the Parties shall be given by the IEC to both the parties for putting up for approval of their respective Competent Authority.
- 16.** Before submitting the draft settlement agreement to BHEL's Competent Authority viz. the Board Level Committee on Alternative Dispute Resolution (BLCADR) for approval, concurrence of the other party's Competent Authority to the draft settlement agreement shall be obtained by the other party and informed to BHEL within 15 days of receipt of the final draft settlement agreement by it. Upon approval by the Competent Authority, the Settlement Agreement would thereafter be signed by the authorized representatives of both the Parties and authenticated by the members of the IEC.
- 17.** In case the Draft Settlement Agreement is rejected by the Competent Authority of BHEL or the other Party, the Conciliation proceedings would stand terminated.
- 18.** A Settlement Agreement shall contain a statement to the effect that each of the person(s) signing thereto (i) is fully authorized by the respective Party(ies) he/she represents, (ii) has fully understood the contents of the same and (iii) is signing on the same out of complete freewill and consent, without any pressure, undue influence.
- 19.** The Settlement Agreement shall thereafter have the same legal status and effect as an arbitration award on agreed terms on the substance of the dispute rendered by an arbitral tribunal passed under section 30 of the Arbitration and Conciliation Act, 1996.
- 20.** Acceptance of the Draft Settlement Agreement/recommendations of the Conciliator and/or signing of the Settlement Agreement by BHEL shall however, be subject to withdrawal/closure of any arbitral and/or judicial proceedings initiated by the concerned Party in regard to such settled issues.
- 21.** Unless otherwise provided for in the agreement, contract or the Memorandum of Understanding, as the case may be, in the event of likelihood of prolonged

absence of the Conciliator or any member of IEC, for any reason/incapacity, the Competent Authority/Head of Unit/Division/Region/Business Group of BHEL may substitute the Conciliator or such member at any stage of the proceedings. Upon appointment of the substitute Conciliator(s), such reconstituted IEC may, with the consent of the Parties, proceed with further Conciliation into the matter either de-novo or from the stage already reached by the previous IEC before the substitution.

22. The proceedings of Conciliation under this Scheme may be terminated as follows:

- a.** On the date of signing of the Settlement agreement by the Parties; or,
- b.** By a written declaration of the IEC, after consultation with the parties, to the effect that further efforts at conciliation are no longer justified, on the date of the declaration; or,
- c.** By a written declaration of the Parties addressed to the IEC to the effect that the Conciliation proceedings are terminated, on the date of the declaration; or,
- d.** By a written declaration of a Party to the other Party and the IEC, if appointed, to the effect that the Conciliation proceedings are terminated, on the date of the declaration; or,
- e.** On rejection of the Draft Settlement Agreement by the Competent Authority of BHEL or the other Party.

23. The Conciliator(s) shall be entitled to following fees and facilities:

Sl No	Particulars	Amount
1	Sitting fees	Each Member shall be paid a Lump Sum fee of Rs 75,000/- for the whole case payable in terms of paragraph No. 27 herein below.
2	Towards drafting of settlement agreement	In cases involving claim and/or counter-claim of up to Rs 5crores. Rs 50,000/- (Sole Conciliator) In cases involving claim and/or counter-claim of exceeding Rs 5 crores but less than Rs 10 crores. Rs 75,000 (per Conciliator)

Sl No	Particulars	Amount
		<p>In cases involving claim and/or counter-claim of more than Rs 10 crores.</p> <p>Rs 1,00,000/- (per Conciliator)</p> <p>Note: The aforesaid fees for the drafting of the Settlement Agreement shall be paid on the,</p> <p>Signing of the Settlement Agreement after approval of the Competent Authority</p> <p>or</p> <p>Rejection of the proposed Settlement Agreement by the Competent Authority of BHEL.</p>
3	Secretarial expenses	<p>Rs 10,000/- (one time) for the whole case for Conciliation by a Sole Member IEC.</p> <p>Where Conciliation is by multi member Conciliators –Rs 30,000/- (one time)- to be paid to the IEC</p>
4	<p>Travel and transportation and stay at outstation Retired Senior Officials of other Public Sector Undertakings (pay scale wise equivalent to or more than E-8 level of BHEL)</p> <p>Others</p>	<p>As per entitlement of the equivalent officer (pay scale wise) in BHEL.</p> <p>As per the extant entitlement of whole time Functional Directors in BHEL.</p> <p>Ordinarily, the IEC Member(s) would be entitled to travel by air Economy Class.</p>
5	Venue for meeting	<p>Unless otherwise agreed in the agreement, contract or the Memorandum of Understanding, as the case may be, the venue/seat of proceedings shall be the location of the concerned Unit / Division / Region /</p>

Sl No	Particulars	Amount
		Business Group of BHEL. Without prejudice to the seat/venue of the Conciliation being at the location of concerned BHEL Unit / Division / Region / Business Group, the IEC after consulting the Parties may decide to hold the proceedings at any other place/venue to facilitate the proceedings. Unless, Parties agree to conduct Conciliation at BHEL premises, the venue is to be arranged by either Party alternately.

- 24.** The parties will bear their own costs including cost of presenting their cases/evidence/witness(es)/expert(s) on their behalf. The parties agree to rely upon documentary evidence in support of their claims and not to bring any oral evidence in IEC proceedings.
- 25.** If any witness(es) or expert(s) is/are, with the consent of the parties, called upon to appear at the instance of the IEC in connection with the matter, then, the costs towards such witness(es)/expert(s) shall be determined by the IEC with the consent of the Parties and the cost so determined shall be borne equally by the Parties.
- 26.** The other expenditures/costs in connection with the Conciliation proceedings as well as the IEC's fees and expenses shall be shared by the Parties equally.
- 27.** Out of the lump sum fees of Rs 75,000/- for Sitting Fees, 50% shall be payable after the first meeting of the IEC and the remaining 50% of the Sitting Fees shall be payable only after termination of the conciliation proceedings in terms of para 22 hereinabove.
- 28.** The travelling, transportation and stay at outstation shall be arranged by concerned Unit as per entitlements as per Serial No. 4 of the Table at para 23 above, and in case such arrangements are not made by the BHEL Unit, the same shall be reimbursed to the IEC on actuals limited to their entitlement as per Serial No. 4 of the Table at Para 23 above against supporting documents. The IEC Member(s) shall submit necessary invoice for claiming the fees/reimbursements.
- 29.** The Parties shall keep confidential all matters relating to the conciliation proceedings. Confidentiality shall extend also to the settlement agreement,

except where its disclosure is necessary for purposes of its implementation and enforcement or as required by or under a law or as per directions of a Court/Governmental authority/ regulatory body, as the case may be.

- 30.** The Parties shall not rely upon or introduce as evidence in any further arbitral or judicial proceedings, whether or not such proceedings relate to the Disputes that is the subject of the Conciliation proceedings:
 - a.** Views expressed or suggestions made by the other party in respect of a possible settlement of the Disputes;
 - b.** admissions made by the other party in the course of the Conciliator proceedings;
 - c.** proposals made by the Conciliator;
 - d.** The fact that the other Party had indicated his willingness to accept a proposal for settlement made by the Conciliator.
- 31.** The Parties shall not present the Conciliator(s) as witness in any Alternative Dispute Resolution or Judicial proceedings in respect of a Disputes that is/was the subject of that particular Conciliation proceeding.
- 32.** None of the Conciliators shall act as an arbitrator or as a representative or counsel of a Party in any arbitral or judicial proceeding in respect of a Disputes that is/was the subject of that particular Conciliation proceeding.
- 33.** The Parties shall not initiate, during the Conciliation proceedings, any arbitral or judicial proceedings in respect of a Disputes that is the subject matter of the Conciliation proceedings except that a Party may initiate arbitral or judicial proceedings where, in his opinion, such proceedings are necessary for preserving his rights including for preventing expiry of period of limitation. Unless terminated as per the provisions of this Scheme, the Conciliation proceedings shall continue notwithstanding the commencement of the arbitral or judicial proceedings and the arbitral or judicial proceedings shall be primarily for the purpose of preserving rights including preventing expiry of period of limitation.
- 34.** The official language of Conciliation proceedings under this Scheme shall be English unless the Parties agree to some other language.

**STATEMENT OF CLAIMS/COUNTER CLAIMS TO BE SUBMITTED TO THE
IEC BY BOTH THE PARTIES**

1. Chronology of the Disputes
2. Brief of the Contract/MoU/Agreement/LOI/LOA
3. Brief history of the Disputes:
4. Issues:
5. Details of Clam(s)/Counter Claim(s):

SI. No.	Description of claim(s)/Counter Claim	Amount (in INR)Or currency applicable in the contract	Relevant contract clause

6. Basis/Ground of claim(s)/counter claim(s) (along with relevant clause of contract)

Note– *The Statement of Claims/ Counter Claims may ideally be restricted to maximum limit of 20 pages. Relevant documents may be compiled and submitted along with the statement of Claims/ Counter Claims. The statement of Claims/ Counter Claims is to be submitted to all IEC members and to the other party by post as well as by email.*

FORMAT FOR NOTICE INVOKING CONCILIATION CLAUSE BY BHEL FOR REFERRING THE DISPUTES TO CONCILIATION THROUGH IEC

To,

M/s. (Stakeholder's name)

Subject: **NOTICE FOR INVOCATION OF THE CONCILIATION CLAUSE OF THE CONTRACT BY BHEL**

Ref: Contract No/MoU/Agreement/LOI/LOA& date _____.

Dear Sir/Madam,

As you are aware, with reference to above referred Contract/MoU/Agreement/LOI/LOA, certain disputes have arisen, which, in spite of several rounds of mutual discussions and various correspondences have remained unresolved. The brief particulars of our claims which arise out of the above- referred Contract/MoU/Agreement/LOI/LOA are reproduced hereunder:

Sl. No.	Claim description	Amount involved

As you are aware, there is a provision in the captioned Contract/MoU/Agreement/LOI/ LOA for referring disputes to conciliation.

In terms of Clause -----of Procedure i.e., Annexure ----- to the Contract/MoU /Agreement / LOI / LOA, we hereby seek your consent to refer the matter to Conciliation by Independent Experts Committee to be appointed by BHEL. You are invited to provide your consent in writing to proceed with conciliation into the above mentioned disputes within a period of 30 days from the date of this letter along with details of counter-claims, if any, which you might have with regard to the subject Contract/ MoU/ Agreement/ LOI/ LOA.

Please note that upon receipt of your consent in writing within 30 days of the date of receipt of this letter by you, BHEL shall appoint suitable person(s) from the BHEL Panel of Conciliators.

This letter is being issued without prejudice to our rights and contentions available under the contract and law.

Thanking you
Yours faithfully

Representative of BHEL

Note: The Format may be suitably modified, as required, based on facts and circumstances of the case.

**FORMAT FOR NOTICE INVOKING CONCILIATION CLAUSE BY A
STAKEHOLDER FOR REFERRING THE DISPUTES TO CONCILIATION
THROUGH IEC**

To,

BHEL (Head of the Unit/Division/Region/Business Group)

Subject: **NOTICE FOR INVOCATION OF THE CONCILIATION CLAUSE OF THE
CONTRACT BY A STAKEHOLDER**

Ref: Contract No/MoU/Agreement/LOI/LOA& date _____.

Dear Sir/Madam,

As you are aware, with reference to above referred Contract/MoU/Agreement/LOI/LOA, certain disputes have arisen, which, in spite of several rounds of mutual discussions and various correspondences have remained unresolved. The brief particulars of our claims which have arisen out of the above-referred Contract/MoU/Agreement/LOI/LOA are enumerated hereunder:

Sl. No.	Claim description	Amount involved

As you are aware, there is a provision in the captioned Contract/MoU/Agreement/LOI/ LOA for referring inter-se disputes of the Parties to conciliation.

We wish to refer the above-said disputes to Conciliation as per the said Clause of the captioned Contract/MoU/Agreement/LOI/ LOA. In terms of Clause -----of Procedure i.e., Annexure ----- to the Contract/MoU /Agreement / LOI / LOA, we hereby invite BHEL to provide its consent in writing to proceed with conciliation into the above mentioned disputes within a period of 30 days from the date of this letter along with details of counter-claims, if any, which it might have with regard to the subject Contract/ MoU/ Agreement/ LOI/ LOA and to appoint suitable person(s) as Conciliator(s) from the BHEL Panel of Conciliators.

This letter is being issued without prejudice to our rights and contentions available under the contract and law.

Thanking you
Yours faithfully

Representative of the Stakeholder

Note: The Format may be suitably modified, as required, based on facts and circumstances of the case.

FORMAT FOR INTIMATION TO THE STAKEHOLDER ABOUT APPOINTMENT OF CONCILIATOR/IEC

To,

M/s. (Stakeholder's name)

Subject: **INTIMATION BY BHEL TO THE STAKEHOLDER AND CONCILIATOR(S) ABOUT APPOINTMENT OF CONCILIATOR/IEC**

Ref: Contract No/MoU/Agreement/LOI/LOA& date _____.

Sir,

This is with reference to letter dated ----- regarding reference of the disputes arising in connection with the subject Contract No /MoU/Agreement/LOI/LOA to conciliation and appointment of Conciliator(s).

In pursuance of the said letter, the said disputes are assigned to conciliation and the following persons are nominated as Conciliator(s) for conciliating and assisting the Parties to amicably resolve the disputes in terms of the Arbitration & Conciliation Act, 1996 and the Procedure ---- to the subject Contract/MoU/Agreement/LOI/LOA, if possible.

Name and contact details of Conciliator(s)

a)

b)

c)

You are requested to submit the Statement of Claims or Counter-Claims (strike off whichever is inapplicable) before the Conciliator(s) in Format 5 (enclosed herewith) as per the time limit as prescribed by the Conciliator(s).

Yours faithfully,

Representative of BHEL

CC: To Conciliator(s)... for Kind Information please.

Encl: As above

Note: The Format may be suitably modified, as required, based on facts and circumstances of the case.

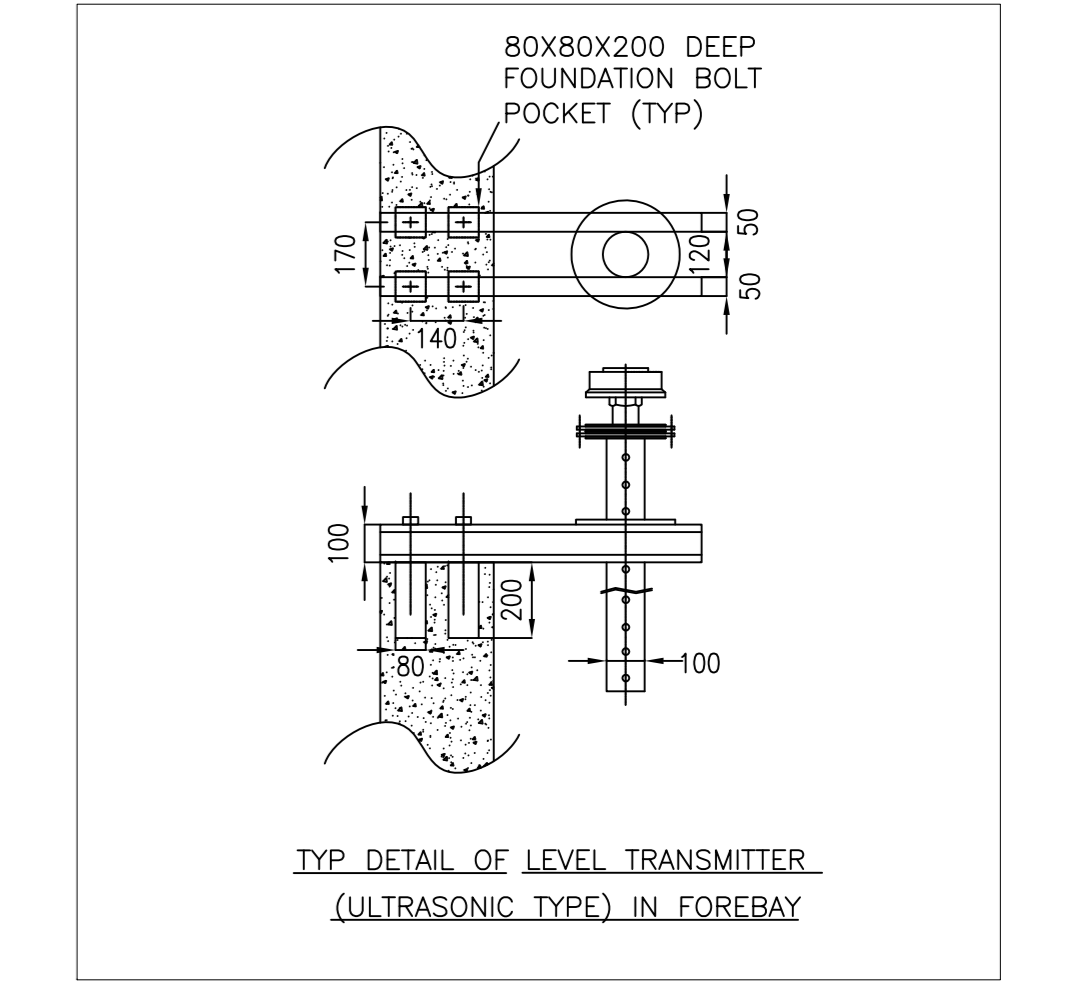
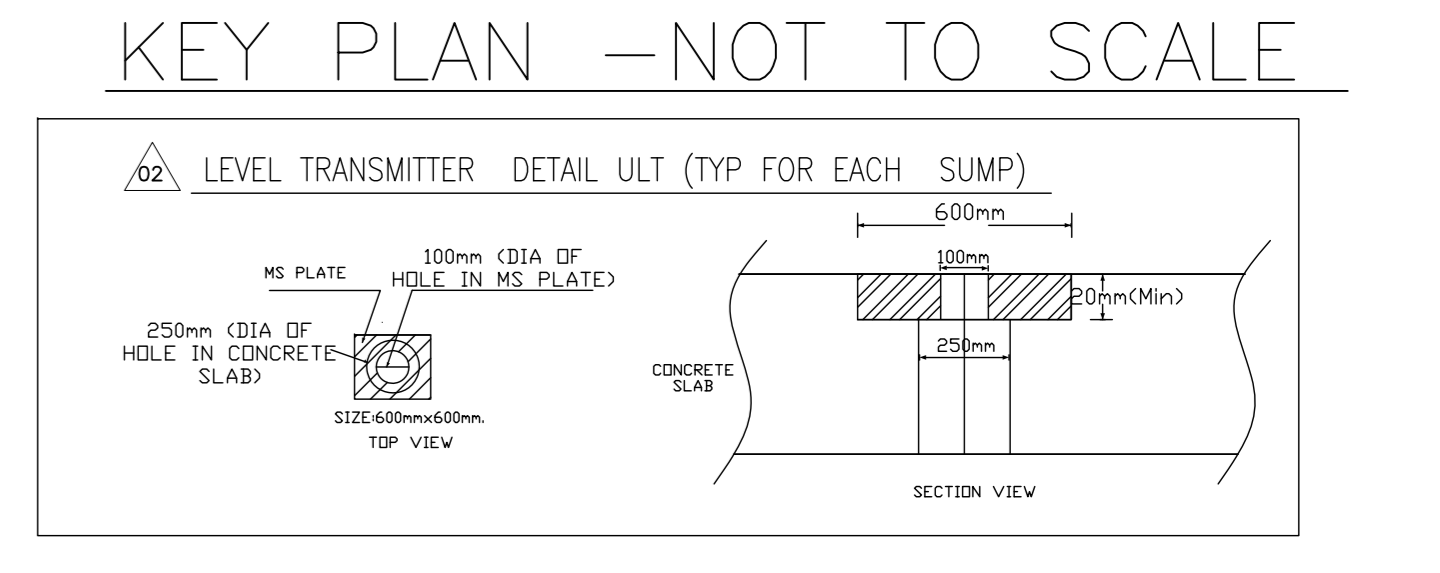
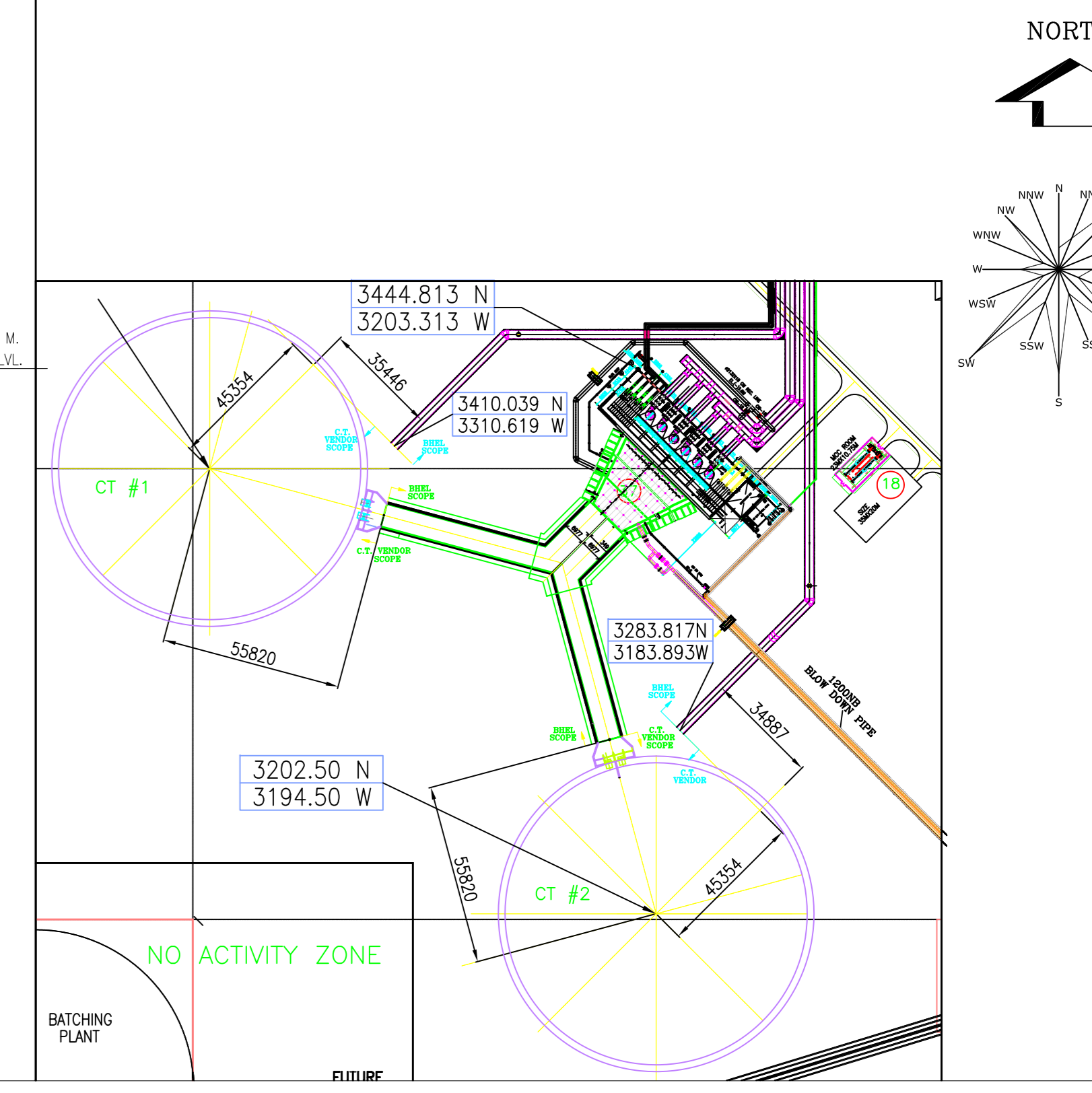
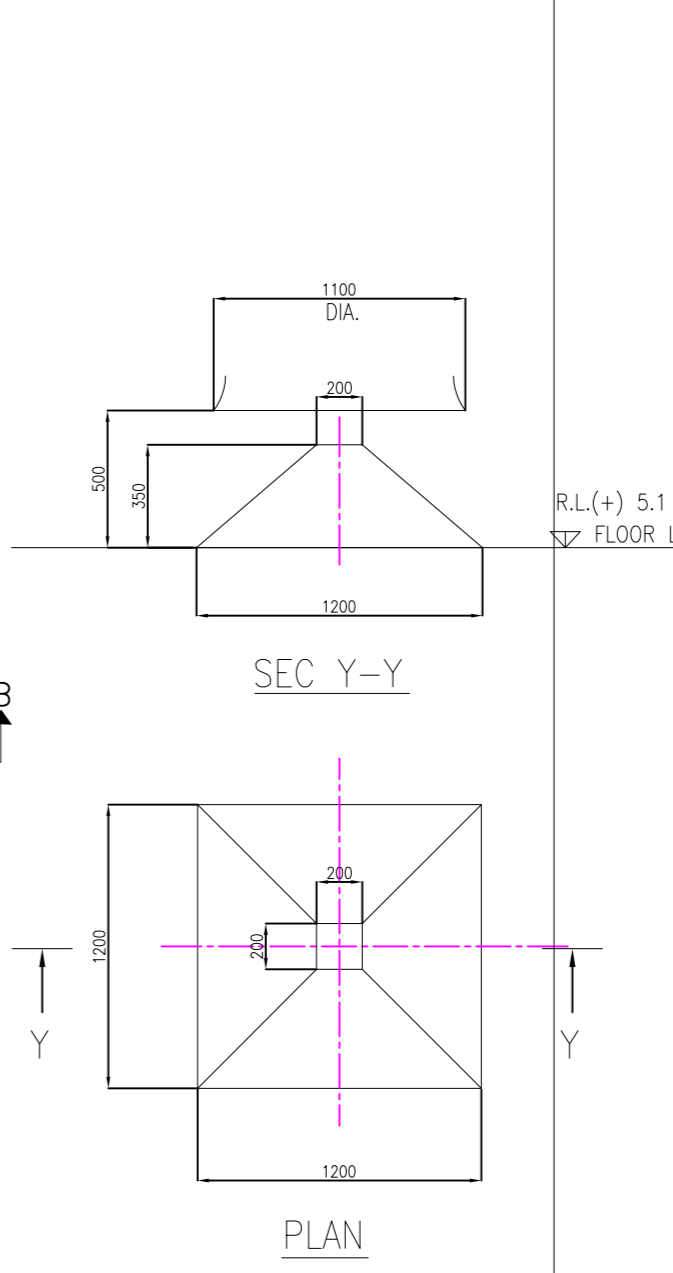
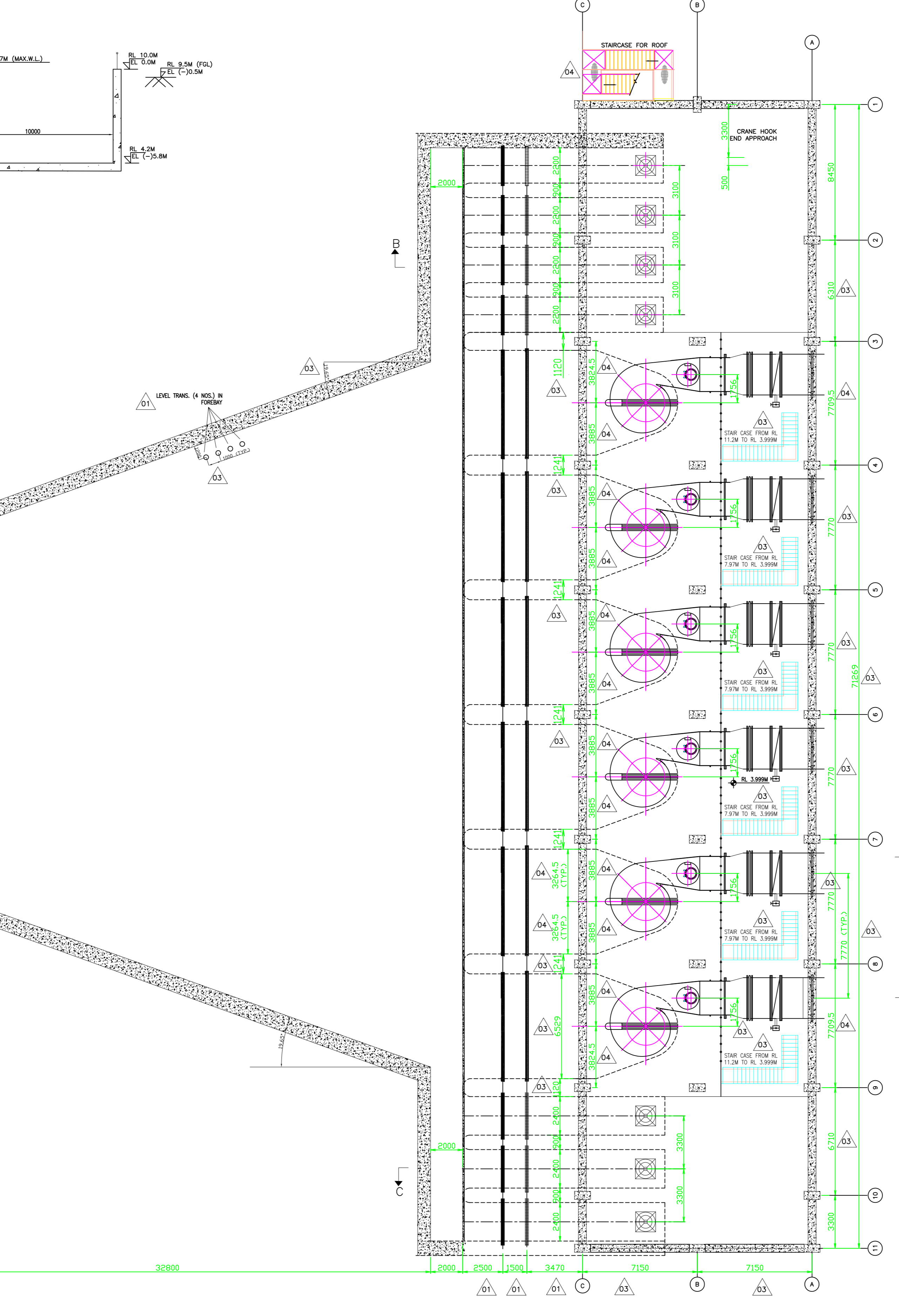
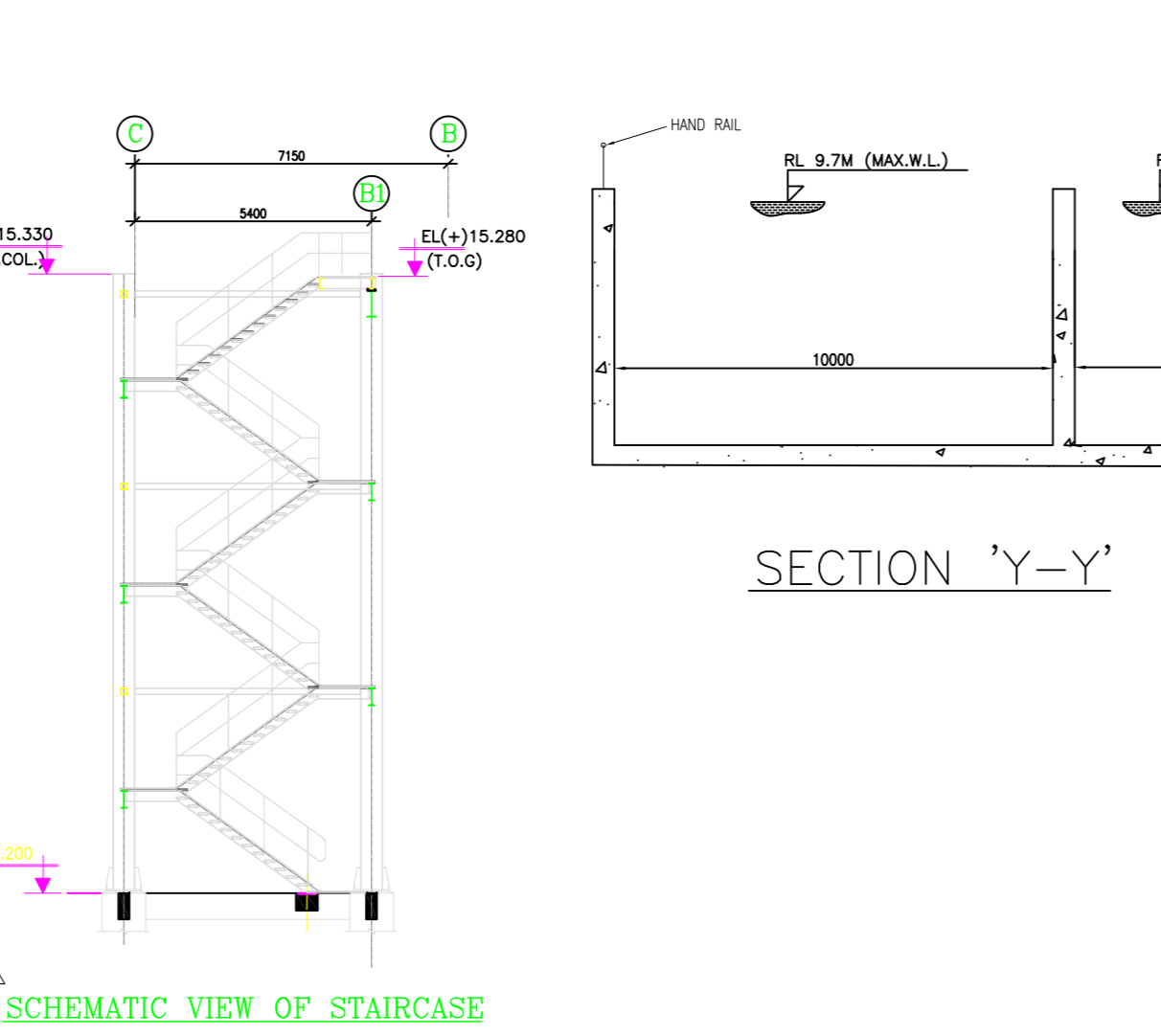
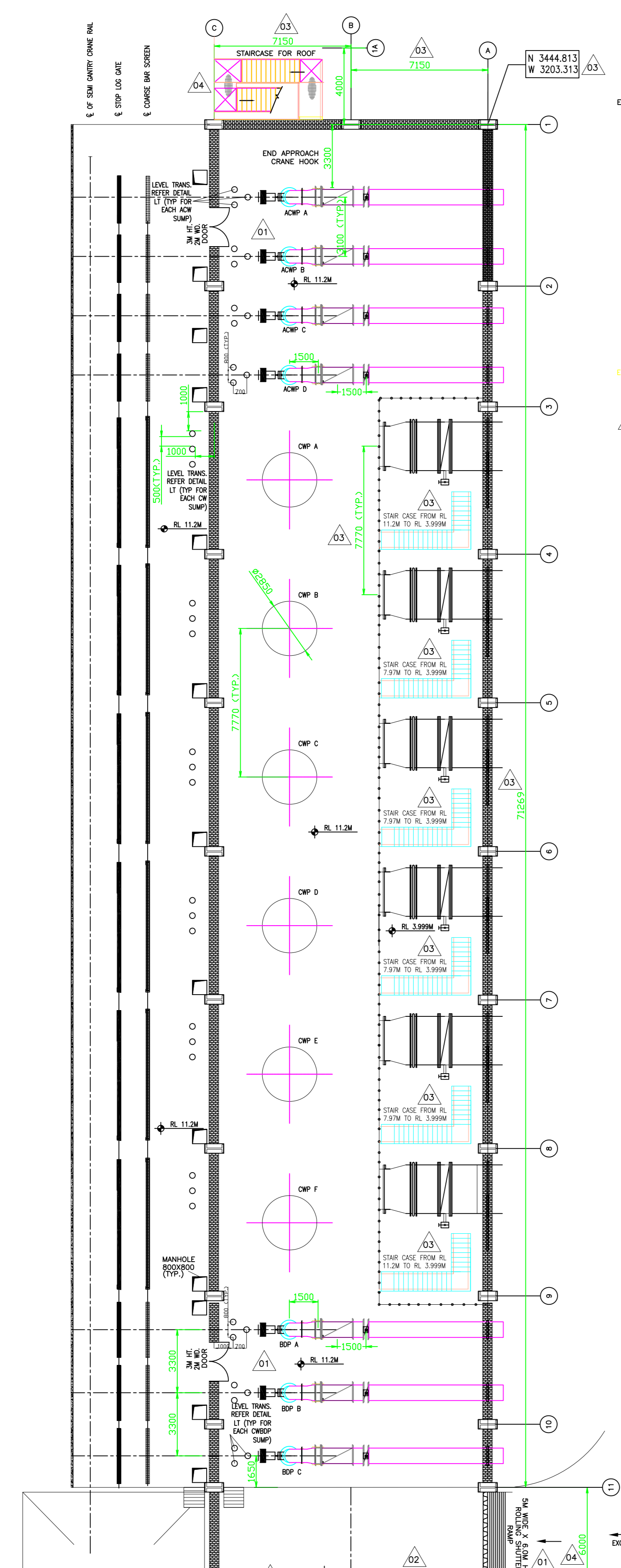

DETAIL - "LT"
SCALE 1:20

PLAN OF C.W. PUMP HOUSE
(CW PUMP FLOOR AREA AT RL 7.97M)
SCALE 1:60

CROSS SECTION VIEW
CHANNEL FROM ONE(1) NDCT

ELEVATION AT ALL CT OUTLET

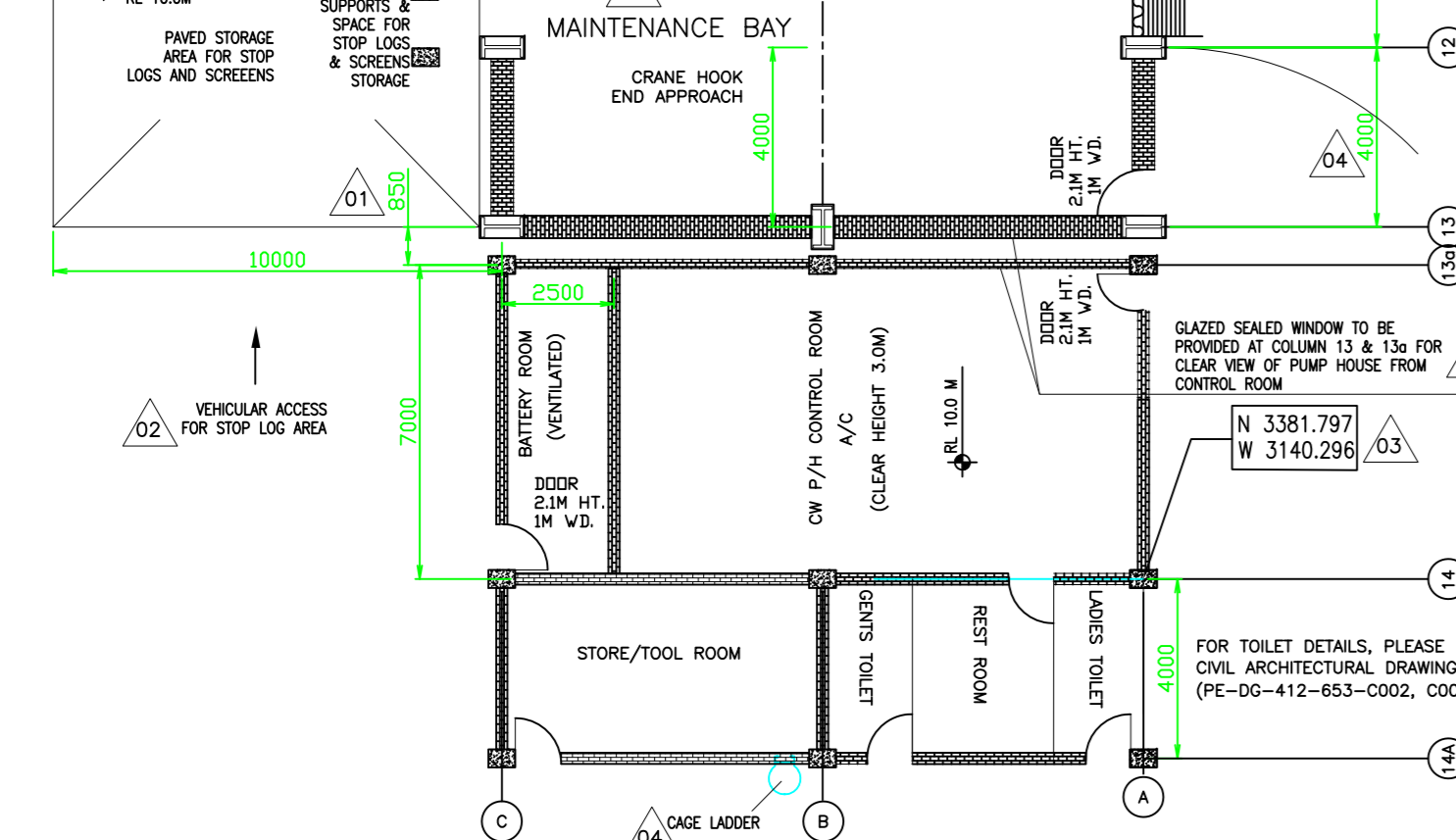

PLAN OF C.W. PUMP HOUSE
(CW MOTOR FLOOR AREA AT RL 11.2M)
SCALE 1:160

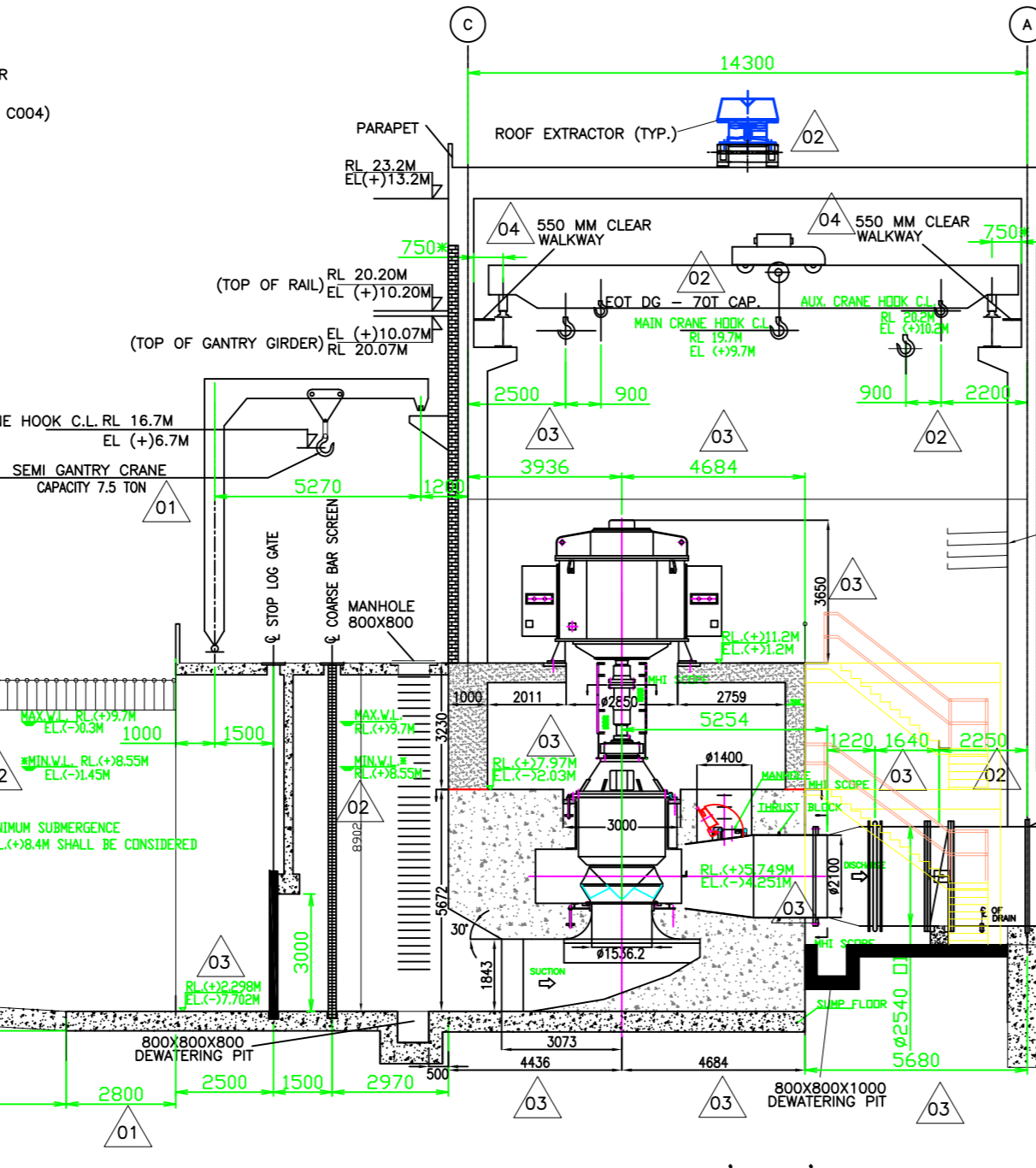

CWP SECTIONAL VIEW 'A-A'
SCALE 1:160

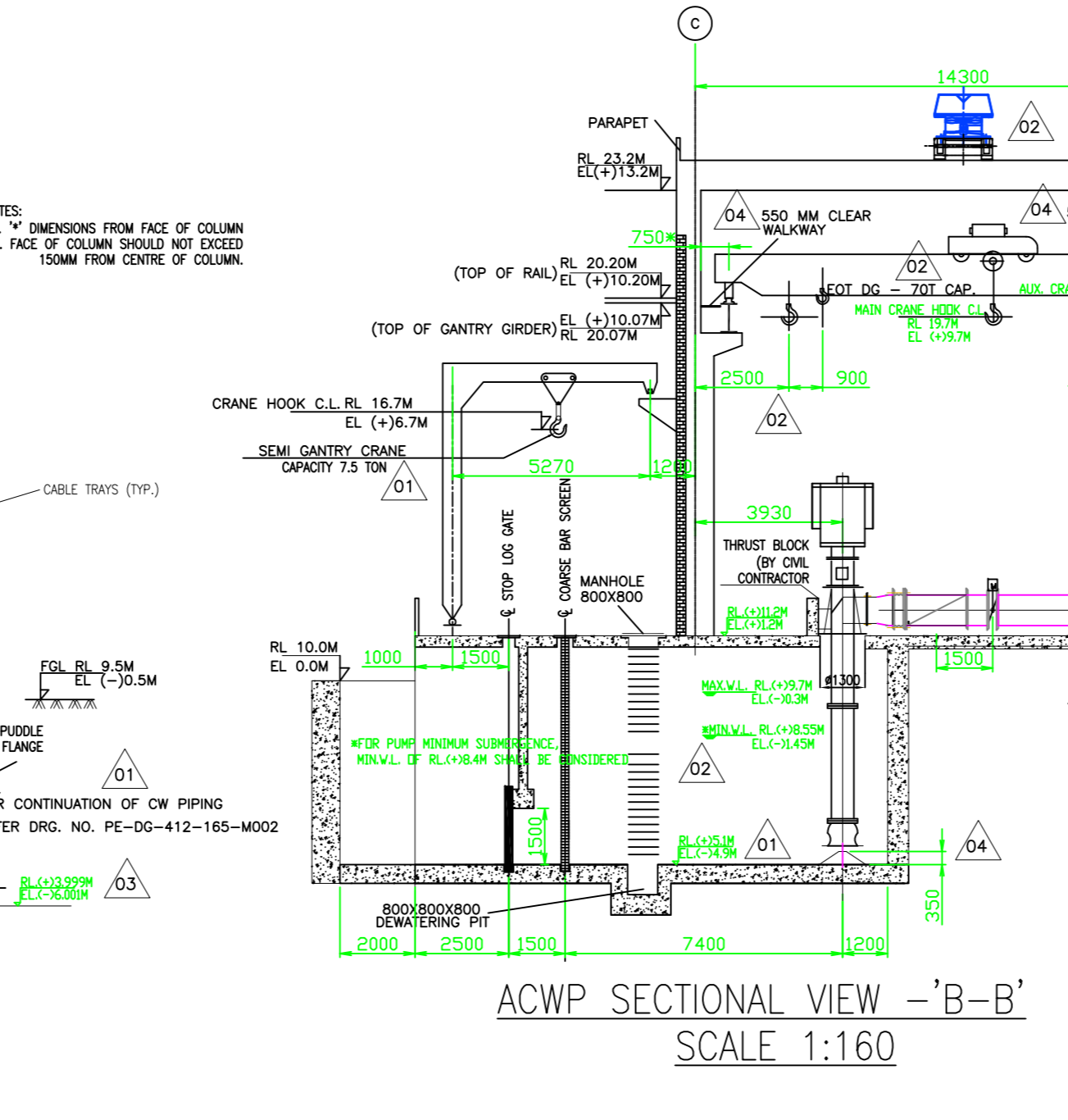

ACWP SECTIONAL VIEW 'B-B'
SCALE 1:160

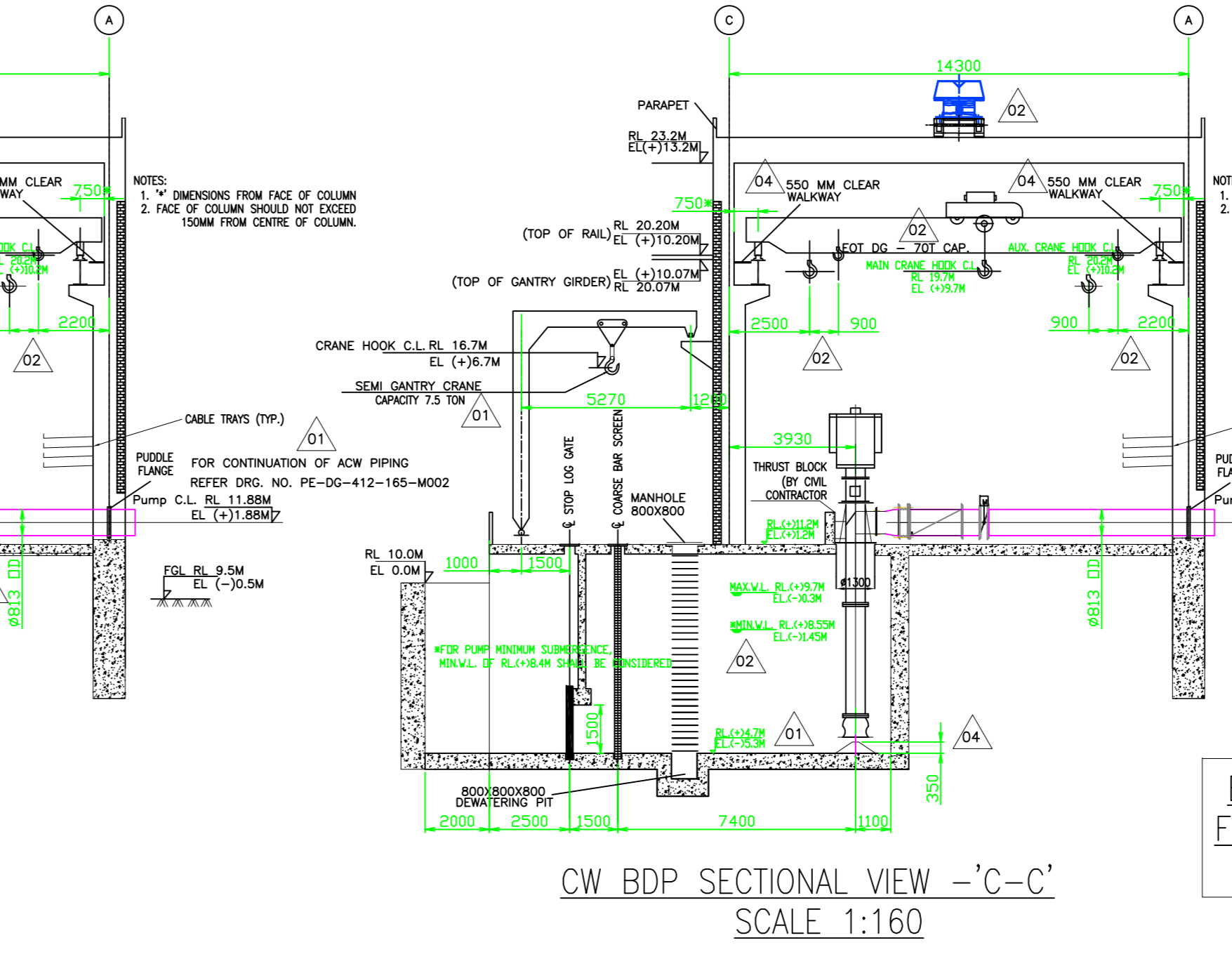

CW BDP SECTIONAL VIEW 'C-C'
SCALE 1:160

- NOTES:
1. ALL DIMENSIONS ARE IN MM AND ALL ELEVATIONS ARE IN METRES UNLESS OTHERWISE STATED.
 2. 55316 GATES (TOTAL 3NO. FOR CW SLUMP, 3 NO. FOR ACW SLUMP & 1 NO. CW BDP SLUMP), 55316 COARSE BAR SCREEN OF 50mm SPACING BETWEEN BARS WITH 55316 FRAME (1 NO. EACH FOR ALL SLUMPS) & 55316 GUSE TO BE FABRICATED AND SUPPLIED BY CIVIL CONTRACTOR.
 3. SLUMP MODEL STUDY SHALL BE CARRIED OUT BY BHEL IHD FOR CW SLUMP & FOREBAY, AND REQUIRED HYDRAULIC ELEMENTS SHALL BE INCORPORATED IN CIVIL WORKS, IF REQUIRED, AS PER STUDIES.
 4. OPENINGS, INSERTS ETC. REQUIRED FOR CW ITEMS, PIPE/VALVE SUPPORTS ETC. SHALL BE INDICATED AFTER FINALIZATION OF RESPECTIVE INSTRUMENTED PIPING LAYOUT ETC.
 5. ACCESS TO ROOF FOR MAINTENANCE OF ROOF EXTRACTOR SHALL BE PROVIDED BY STAIRCASE.
 6. 1 NO. PORTABLE STAIR, CUM LADDER SHALL BE PROVIDED FOR ACCESS TO TOP BEARING OF MOTOR BY CIVIL CONTRACTOR.
 7. THROAT OF CONCRETE STORAGE SHALL BE MINIMUM 250 MM.
 8. STOP LOG GATE HEIGHT SHALL BE DESIGNED FOR SLUMP OPENING HEIGHT VIZ 3000MM FOR CW & 1500MM FOR ACW & BDP SLUMP.
 9. COARSE BAR SCREEN HEIGHT SHALL BE UP TO PUMP FLOOR LEVEL (RL 11.2M).
 10. REFERENCE ENGINEERING DRAWINGS:
 - (a) CW & ACW PAID: PE-05-412-165-M001
 - (b) CW PUMP GA
 - (c) CW CHORINATION
 - (d) CHORINATION LAYOUT (COMMON WITH ELECTRO-CHORINATION) PE-05-412-100-E024
 - (e) CW CHORINATION
 - (f) CHORINATION LAYOUT (COMMON WITH ELECTRO-CHORINATION) PE-05-412-165-M002
 - (g) CHORINATION LAYOUT (COMMON WITH ELECTRO-CHORINATION) PE-05-412-165-M003
 - (h) CHORINATION LAYOUT (COMMON WITH ELECTRO-CHORINATION) PE-05-412-165-M004
 - (i) CHORINATION LAYOUT (COMMON WITH ELECTRO-CHORINATION) PE-05-412-165-M005
 - (j) CHORINATION LAYOUT (COMMON WITH ELECTRO-CHORINATION) PE-05-412-165-M006
 - (k) CHORINATION LAYOUT (COMMON WITH ELECTRO-CHORINATION) PE-05-412-165-M007
 - (l) CHORINATION LAYOUT (COMMON WITH ELECTRO-CHORINATION) PE-05-412-165-M008
 - (m) CHORINATION LAYOUT (COMMON WITH ELECTRO-CHORINATION) PE-05-412-165-M009
 - (n) CHORINATION LAYOUT (COMMON WITH ELECTRO-CHORINATION) PE-05-412-165-M010
 - (o) CHORINATION LAYOUT (COMMON WITH ELECTRO-CHORINATION) PE-05-412-165-M011
 - (p) CHORINATION LAYOUT (COMMON WITH ELECTRO-CHORINATION) PE-05-412-165-M012
 - (q) CHORINATION LAYOUT (COMMON WITH ELECTRO-CHORINATION) PE-05-412-165-M013
 - (r) CHORINATION LAYOUT (COMMON WITH ELECTRO-CHORINATION) PE-05-412-165-M014
 - (s) CHORINATION LAYOUT (COMMON WITH ELECTRO-CHORINATION) PE-05-412-165-M015
 - (t) CHORINATION LAYOUT (COMMON WITH ELECTRO-CHORINATION) PE-05-412-165-M016
 - (u) CHORINATION LAYOUT (COMMON WITH ELECTRO-CHORINATION) PE-05-412-165-M017
 - (v) CHORINATION LAYOUT (COMMON WITH ELECTRO-CHORINATION) PE-05-412-165-M018
 - (w) CHORINATION LAYOUT (COMMON WITH ELECTRO-CHORINATION) PE-05-412-165-M019
 - (x) CHORINATION LAYOUT (COMMON WITH ELECTRO-CHORINATION) PE-05-412-165-M020
 - (y) CHORINATION LAYOUT (COMMON WITH ELECTRO-CHORINATION) PE-05-412-165-M021
 - (z) CHORINATION LAYOUT (COMMON WITH ELECTRO-CHORINATION) PE-05-412-165-M022
 - (aa) CHORINATION LAYOUT (COMMON WITH ELECTRO-CHORINATION) PE-05-412-165-M023
 - (ab) CHORINATION LAYOUT (COMMON WITH ELECTRO-CHORINATION) PE-05-412-165-M024
 - (ac) CHORINATION LAYOUT (COMMON WITH ELECTRO-CHORINATION) PE-05-412-165-M025
 - (ad) CHORINATION LAYOUT (COMMON WITH ELECTRO-CHORINATION) PE-05-412-165-M026
 - (ae) CHORINATION LAYOUT (COMMON WITH ELECTRO-CHORINATION) PE-05-412-165-M027
 - (af) CHORINATION LAYOUT (COMMON WITH ELECTRO-CHORINATION) PE-05-412-165-M028
 - (ag) CHORINATION LAYOUT (COMMON WITH ELECTRO-CHORINATION) PE-05-412-165-M029
 - (ah) CHORINATION LAYOUT (COMMON WITH ELECTRO-CHORINATION) PE-05-412-165-M030
 - (ai) CHORINATION LAYOUT (COMMON WITH ELECTRO-CHORINATION) PE-05-412-165-M031
 - (aj) CHORINATION LAYOUT (COMMON WITH ELECTRO-CHORINATION) PE-05-412-165-M032
 - (ak) CHORINATION LAYOUT (COMMON WITH ELECTRO-CHORINATION) PE-05-412-165-M033
 - (al) CHORINATION LAYOUT (COMMON WITH ELECTRO-CHORINATION) PE-05-412-165-M034
 - (am) CHORINATION LAYOUT (COMMON WITH ELECTRO-CHORINATION) PE-05-412-165-M035
 - (an) CHORINATION LAYOUT (COMMON WITH ELECTRO-CHORINATION) PE-05-412-165-M036
 - (ao) CHORINATION LAYOUT (COMMON WITH ELECTRO-CHORINATION) PE-05-412-165-M037
 - (ap) CHORINATION LAYOUT (COMMON WITH ELECTRO-CHORINATION) PE-05-412-165-M038
 - (aq) CHORINATION LAYOUT (COMMON WITH ELECTRO-CHORINATION) PE-05-412-165-M039
 - (ar) CHORINATION LAYOUT (COMMON WITH ELECTRO-CHORINATION) PE-05-412-165-M040
 - (as) CHORINATION LAYOUT (COMMON WITH ELECTRO-CHORINATION) PE-05-412-165-M041
 - (at) CHORINATION LAYOUT (COMMON WITH ELECTRO-CHORINATION) PE-05-412-165-M042
 - (au) CHORINATION LAYOUT (COMMON WITH ELECTRO-CHORINATION) PE-05-412-165-M043
 - (av) CHORINATION LAYOUT (COMMON WITH ELECTRO-CHORINATION) PE-05-412-165-M044
 - (aw) CHORINATION LAYOUT (COMMON WITH ELECTRO-CHORINATION) PE-05-412-165-M045
 - (ax) CHORINATION LAYOUT (COMMON WITH ELECTRO-CHORINATION) PE-05-412-165-M046
 - (ay) CHORINATION LAYOUT (COMMON WITH ELECTRO-CHORINATION) PE-05-412-165-M047
 - (az) CHORINATION LAYOUT (COMMON WITH ELECTRO-CHORINATION) PE-05-412-165-M048
 - (ba) CHORINATION LAYOUT (COMMON WITH ELECTRO-CHORINATION) PE-05-412-165-M049
 - (bb) CHORINATION LAYOUT (COMMON WITH ELECTRO-CHORINATION) PE-05-412-165-M050
 - (bc) CHORINATION LAYOUT (COMMON WITH ELECTRO-CHORINATION) PE-05-412-165-M051
 - (bd) CHORINATION LAYOUT (COMMON WITH ELECTRO-CHORINATION) PE-05-412-165-M052
 - (be) CHORINATION LAYOUT (COMMON WITH ELECTRO-CHORINATION) PE-05-412-165-M053
 - (bf) CHORINATION LAYOUT (COMMON WITH ELECTRO-CHORINATION) PE-05-412-165-M054
 - (bg) CHORINATION LAYOUT (COMMON WITH ELECTRO-CHORINATION) PE-05-412-165-M055
 - (bh) CHORINATION LAYOUT (COMMON WITH ELECTRO-CHORINATION) PE-05-412-165-M056
 - (bi) CHORINATION LAYOUT (COMMON WITH ELECTRO-CHORINATION) PE-05-412-165-M057
 - (bj) CHORINATION LAYOUT (COMMON WITH ELECTRO-CHORINATION) PE-05-412-165-M058
 - (bk) CHORINATION LAYOUT (COMMON WITH ELECTRO-CHORINATION) PE-05-412-165-M059
 - (bl) CHORINATION LAYOUT (COMMON WITH ELECTRO-CHORINATION) PE-05-412-165-M060
 - (bm) CHORINATION LAYOUT (COMMON WITH ELECTRO-CHORINATION) PE-05-412-165-M061
 - (bn) CHORINATION LAYOUT (COMMON WITH ELECTRO-CHORINATION) PE-05-412-165-M062
 - (bo) CHORINATION LAYOUT (COMMON WITH ELECTRO-CHORINATION) PE-05-412-165-M063
 - (bp) CHORINATION LAYOUT (COMMON WITH ELECTRO-CHORINATION) PE-05-412-165-M064
 - (bq) CHORINATION LAYOUT (COMMON WITH ELECTRO-CHORINATION) PE-05-412-165-M065
 - (br) CHORINATION LAYOUT (COMMON WITH ELECTRO-CHORINATION) PE-05-412-165-M066
 - (bs) CHORINATION LAYOUT (COMMON WITH ELECTRO-CHORINATION) PE-05-412-165-M067
 - (bt) CHORINATION LAYOUT (COMMON WITH ELECTRO-CHORINATION) PE-05-412-165-M068
 - (bu) CHORINATION LAYOUT (COMMON WITH ELECTRO-CHORINATION) PE-05-412-165-M069
 - (bv) CHORINATION LAYOUT (COMMON WITH ELECTRO-CHORINATION) PE-05-412-165-M070
 - (bw) CHORINATION LAYOUT (COMMON WITH ELECTRO-CHORINATION) PE-05-412-165-M071
 - (bx) CHORINATION LAYOUT (COMMON WITH ELECTRO-CHORINATION) PE-05-412-165-M072
 - (by) CHORINATION LAYOUT (COMMON WITH ELECTRO-CHORINATION) PE-05-412-165-M073
 - (bz) CHORINATION LAYOUT (COMMON WITH ELECTRO-CHORINATION) PE-05-412-165-M074
 - (ca) CHORINATION LAYOUT (COMMON WITH ELECTRO-CHORINATION) PE-05-412-165-M075
 - (cb) CHORINATION LAYOUT (COMMON WITH ELECTRO-CHORINATION) PE-05-412-165-M076
 - (cc) CHORINATION LAYOUT (COMMON WITH ELECTRO-CHORINATION) PE-05-412-165-M077
 - (cd) CHORINATION LAYOUT (COMMON WITH ELECTRO-CHORINATION) PE-05-412-165-M078
 - (ce) CHORINATION LAYOUT (COMMON WITH ELECTRO-CHORINATION) PE-05-412-165-M079
 - (cf) CHORINATION LAYOUT (COMMON WITH ELECTRO-CHORINATION) PE-05-412-165-M080
 - (cg) CHORINATION LAYOUT (COMMON WITH ELECTRO-CHORINATION) PE-05-412-165-M081
 - (ch) CHORINATION LAYOUT (COMMON WITH ELECTRO-CHORINATION) PE-05-412-165-M082
 - (ci) CHORINATION LAYOUT (COMMON WITH ELECTRO-CHORINATION) PE-05-412-165-M083
 - (cj) CHORINATION LAYOUT (COMMON WITH ELECTRO-CHORINATION) PE-05-412-165-M084
 - (ck) CHORINATION LAYOUT (COMMON WITH ELECTRO-CHORINATION) PE-05-412-165-M085
 - (cl) CHORINATION LAYOUT (COMMON WITH ELECTRO-CHORINATION) PE-05-412-165-M086
 - (cm) CHORINATION LAYOUT (COMMON WITH ELECTRO-CHORINATION) PE-05-412-165-M087
 - (cn) CHORINATION LAYOUT (COMMON WITH ELECTRO-CHORINATION) PE-05-412-165-M088
 - (co) CHORINATION LAYOUT (COMMON WITH ELECTRO-CHORINATION) PE-05-412-165-M089
 - (cp) CHORINATION LAYOUT (COMMON WITH ELECTRO-CHORINATION) PE-05-412-165-M090
 - (cq) CHORINATION LAYOUT (COMMON WITH ELECTRO-CHORINATION) PE-05-412-165-M091
 - (cr) CHORINATION LAYOUT (COMMON WITH ELECTRO-CHORINATION) PE-05-412-165-M092
 - (cs) CHORINATION LAYOUT (COMMON WITH ELECTRO-CHORINATION) PE-05-412-165-M093
 - (ct) CHORINATION LAYOUT (COMMON WITH ELECTRO-CHORINATION) PE-05-412-165-M094
 - (cu) CHORINATION LAYOUT (COMMON WITH ELECTRO-CHORINATION) PE-05-412-165-M095
 - (cv) CHORINATION LAYOUT (COMMON WITH ELECTRO-CHORINATION) PE-05-412-165-M096
 - (cw) CHORINATION LAYOUT (COMMON WITH ELECTRO-CHORINATION) PE-05-412-165-M097
 - (cx) CHORINATION LAYOUT (COMMON WITH ELECTRO-CHORINATION) PE-05-412-165-M098
 - (cy) CHORINATION LAYOUT (COMMON WITH ELECTRO-CHORINATION) PE-05-412-165-M099
 - (cz) CHORINATION LAYOUT (COMMON WITH ELECTRO-CHORINATION) PE-05-412-165-M100

EL 0.00M CORRESPOND TO RL 10.00M, WHICH IS FFL OF TG BUILDING. ALL ELEVATIONS ARE MARKED WITH RESPECT TO THIS LEVEL.

NO.	DATE	DESCRIPTION	BY	CHECKED	APPROVED
01	10/10/2024	ISSUED FOR PERMIT
02	10/10/2024	ISSUED FOR CONSTRUCTION
03	10/10/2024	ISSUED FOR OPERATION

PROJECT: SUPPLY AND INSTALLATION OF THERMAL POWER PROJECT AT ASH DTKR OF JHARKHAND

CONSULTANT: SEVEN PRIVATE LIMITED, SEVEN HOUSE, NEW DELHI

MECHANICAL GA OF CW PUMP HOUSE

DATE: 10/10/2024

SCALE: AS SHOWN

DRWING NO: PE-05-412-165-M004

SHEET NO. OF 16

