

Bharat Heavy Electricals Limited
High Pressure Boiler Plant
Tiruchirappalli – 620 014. India
Civil Engineering Department (Township)

TENDER DOCUMENT (QUALIFICATION BID)

PACKAGE	Name of Work	Tender Notice No	Tender Schedule No	Estimate /Tender Value	EMD
(PACKAGE-J)	MAINTENANCE OF ROAD WORKS AT BHEL TOWNSHIP	CT:TN:003/18-19	CT:TS:012/18-19	₹ 80,00,000.00 (RUPEES NINETY SIX EIGHTY LAKH ONLY)	Rs. 96,000.00 (RUPEES NINETY SIX THOUSAND ONLY)
(PACKAGE-K)	MAINTENANCE OF WATER SUPPLY & PLUMBING WORKS AT BHEL TOWNSHIP-TRICHY	CT:TN:003/18-19	CT:TS:013/18-19	₹ 64,00,000.00 (RUPEES SIXTY FOUR LAKH ONLY)	Rs. 76800.00 (RUPEES SEVENTY SIX THOUSAND EIGHT HUNDRED ONLY)
(PACKAGE-L)	MAINTENANCE OF HORTICULTURE WORKS AT BHEL TOWNSHIP, TRICHY	CT:TN:003/18-19	CT:TS:014/18-19	₹ 40,00,000.00 (RUPEES FORTY LAKH ONLY)	Rs. 48,000.00 (RUPEES FORTY EIGHT THOUSAND ONLY)
(PACKAGE-M)	STRUCTURAL STEEL WORKS AT BHEL TOWNSHIP, TRICHY	CT:TN:003/18-19	CT:TS:015/18-19	₹ 28,00,000.00 (RUPEES TWENTY EIGHT LAKH ONLY)	Rs. 33600.00 (RUPEES THIRTY THREE THOUSAND SIX HUNDRED ONLY)

IMPORTANT NOTE:

EMD & Tender cost Exemption will not be allowed to MSME / NSIC vendors for works contract. This tender is categorized as a works contract. Hence Tenderers are compulsorily need to remit the required EMD/EMDs & Tender cost in order to participate in the Tender. Tender without corresponding EMD /EMDs & Tender cost will be summarily rejected and will not be considered for any reasons. Split and award in the ratio of 60% : 40% respectively to L1 and L2 at the L1 quoted percentage is applicable to all the four packages **J,K,L&M** for those Estimate / Tender Value more than Rs.25 Lakhs.

BHEL,TRICHY-14
CIVIL ENGINEERING DEPARTMENT (Township)

BHE: P:C:T:09
To

Dt. 23.04.18

The Tenderer
Dear Sirs,

1. SEALED TENDERS for the above work are hereby invited from contractors experienced in works of similar kind and magnitude. This tender comprises of **4 packages**. Vendors may choose any/all package they wish to opt for. TENDERS must be submitted in sealed cover consisting of Minimum 3 (THREE) inner sealed covers all super scribing the name of work, tender schedule no, etc. for each package.

Cover 1 - One DD for Rs 750 for Tender cost for all four packages & EMD for each package (if contractor quotes for more than one package, corresponding EMD to be submitted for each package).

Cover 2 - One Qualification bid for all four packages, Corrigendum & credentials.

Cover 3 and so on - if contractor quotes for more than one package, Corresponding Price bid Pages has to be kept in separate cover, super scribing tender schedule no, Package Name & Name of work.

2. Qualification bid cover shall contain duly filled in qualification bid document signed by the tenderer in all the pages with documentary evidences for pre-qualification such as experience, value of work executed in the similar nature of work, etc. Any bid without proper documentary evidence for pre-qualification shall not be considered for further evaluation.

3. The Price Bid cover shall contain price bid document duly filled in and signed by the tenderer in all the pages. The tenderer has to quote most competitive rate in Percentage Below (100-X) % / At par (100%) / Above (100+X) % of the SR 2013-14 rates provided in the corresponding pages of Price bid in separate inner covers. Participating packages alone shall be separated and covered in separate covers.

(Important Note: One time EMD is no more applicable for tender, as per recent corporate guidelines. Hence tenderers who had previously remitted one time EMD, shall have to necessarily take EMD of specified amount mentioned for this tender)

4. The late tenders received after the tender submission / Opening time will be summarily Rejected and will not be considered for any reasons.

5. You / your authorized representative may participate in the tender opening with authorization letter for Tender opening.

Latest updates on the important dates, Amendments, Correspondences, Corrigenda, Clarifications, Changes, Errata, Modifications, Revisions etc., to tender specifications will be hosted in BHEL Web page (WWW.bhel.com → Tender Notifications → view Corrigendum's) **and not in the News Papers**. Bidders to keep themselves updated with all such information's.

The tenderers who are desirous of sending their tender documents through your authorized representative / by post / by courier are advised to send the same well in advance so as to reach the office of **SM / Civil / Planning, Design & QC (F&T), Bldg.53, BHEL, Trichy-620014, Tamil Nadu** on or before **15.05.2018 at 10.00 hrs.**

A pre bid meeting is organized on 03.05.2018 at 10.00 hrs to clarify doubts on this tender at 53 Building Civil Conference Hall, 53 Building, BHEL, Tiruchi - 14

Clarification if any, can be obtained contacting following email ravindran.p@bhel.in / akila@bhel.in , phone No. 0431 –2571937/257 1214 Fax No. : 0431 – 2520710.

Kindly acknowledge the receipt of the entire set of tender document.

Thanking you,
Encl: E Format

Yours faithfully
For and on behalf of BHEL
SM / Civil/ Planning, Design & Qc
BUILDING No.53, Ground floor

OPTIONS PAGE

S No	PACKAGE	Description	TENDER /ESTIMATE AMOUNT (Rs)	EMD Amount (Rs)	Willingness	<u>YES / NO</u> <u>(Vendors should write their option either Yes/No)</u>
1	(PACKAGE-J)	MAINTENANCE OF ROAD WORKS AT BHEL TOWNSHIP CT:TS:12/18-19	₹ 80,00,000.00 (RUPEES EIGHTY LAKH ONLY)	Rs. 96,000.00 (RUPEES NINETY SIX THOUSAND ONLY)	I WISH TO APPLY FOR THIS WORK AND HAVE ENCLOSED DD OF SPECIFIED AMOUNT,	
2	(PACKAGE-K)	MAINTENANCE OF WATER SUPPLY & PLUMBING WORKS AT BHEL TOWNSHIP-TRICHY CT:TS:13/18-19	₹ 64,00,000.00 (RUPEES SIXTY FOUR LAKH ONLY)	Rs. 76800.00 (RUPEES SEVENTY SIX THOUSAND EIGHT HUNDRED ONLY)	I WISH TO APPLY FOR THIS WORK AND HAVE ENCLOSED DD OF SPECIFIED AMOUNT,	
3	(PACKAGE-L)	MAINTENANCE OF HORTICULTURE WORKS AT BHEL TOWNSHIP, TRICHY CT:TS:14/18-19	₹ 40,00,000.00 (RUPEES FORTY LAKH ONLY)	Rs. 48,000.00 (RUPEES FORTY EIGHT THOUSAND ONLY)	I WISH TO APPLY FOR THIS WORK AND HAVE ENCLOSED DD OF SPECIFIED AMOUNT	
4	(PACKAGE-M)	STRUCTURAL STEEL WORKS AT BHEL TOWNSHIP, TRICHY CT:TS:15/18-19	₹ 28,00,000.00 (RUPEES TWENTY EIGHT LAKH ONLY)	Rs. 33600.00 (RUPEES THIRTY THREE THOUSAND SIX HUNDRED ONLY)	I WISH TO APPLY FOR THIS WORK AND HAVE ENCLOSED DD OF SPECIFIED AMOUNT	

PLS NOTE THAT EMD OF SPECIFIED AMOUNT FOR EVERY PACKAGE HAS TO BE ENCLOSED INDIVIDUALLY. For example, IF YOU WISH TO APPLY FOR ANY TWO WORKS, THE CORRESPONDING 2-DD'S SHALL BE AVAILABLE

Important Note: The Contractors have to take print out of this page alone as additional copy and file at the outside cover of the Qualification Bid also, in order to know the packages for which application has been submitted.

PART-I (TECHNO COMMERCIAL BID)

COVER- 1-EMD/s & Tender Cost(each cover shall clearly specify Tender Schedule no, name of work applied for.)

SHOULD CONTAIN EMD OF

Tender Schedule No.	Name of the work	Tender Estimate (Rs)	EMD Amount (Rs)	Tender Cost (Rs)
CT:TS:012/ 18-19	MAINTENANCE OF ROAD WORKS AT BHEL TOWNSHIP	₹ 80,00,000.00 (RUPEES EIGHTY LAKH ONLY)	Rs. 96,000.00 (RUPEES NINETY SIX THOUSAND ONLY)	Rs.750 (RUPEES SEVEN HUNDRED AND FIFTY ONLY)
CT:TS:013/ 18-19	MAINTENANCE OF WATER SUPPLY & PLUMBING WORKS AT BHEL TOWNSHIP-TRICHY	₹ 64,00,000.00 (RUPEES SIXTY FOUR LAKH ONLY)	Rs. 76800.00 (RUPEES SEVENTY SIX THOUSAND EIGHT HUNDRED ONLY)	
CT:TS:014/ 18-19	MAINTENANCE OF HORTICULTURE WORKS AT BHEL TOWNSHIP, TRICHY	₹ 40,00,000.00 (RUPEES FORTY LAKH ONLY)	Rs. 48,000.00 (RUPEES FORTY EIGHT THOUSAND ONLY)	
CT:TS:015/ 18-19	STRUCTURAL STEEL WORKS AT BHEL TOWNSHIP, TRICHY	₹ 28,00,000.00 (RUPEES TWENTY EIGHT LAKH ONLY)	Rs. 33600.00 (RUPEES THIRTY THREE THOUSAND SIX HUNDRED ONLY)	

Important Note: EMD & Tender cost Exemption will not be allowed to MSME / NSIC vendors for works contract (Applicable to this AMC). Hence Tenderers are compulsorily needed to remit the required EMD & Tender cost in order to participate in the Tender. Contractor is required to submit only one Qualification Bid with one set of required eligibility criteria documents with attestation but individual price Bids need to be submitted for every participating tender schedules (every package) in separate covers. One DD of Rs.750 for tender cost is enough to participate either in any one or more than one packages but corresponding EMD's should be accompanied with every package

COVER 2- SHOULD CONTAIN TECHNICAL BID & SUBSEQUENT CORRIGENDUM/s, IF ANY

One technical bid document with single set of qualifying documents is sufficient. The technical bid cover shall clearly specify Tender Schedule no, name of work applied for. Please refer qualifying criteria for more details.

COVER-3 SHOULD CONTAIN PRICE BID/s

Each cover for each package shall clearly specify Tender Schedule no, name of work applied for and containing Corresponding Price bid Pages only.

**BHARAT HEAVY ELECTRICALS LIMITED,
TIRUCHIRAPPALLI-620 014
NOTICE INVITING TENDER**

1.	Tender Ref No:	CT:TN:003/18-19
2.	Name of work	ROAD,WATER SUPPLY & PLUMBING, HORTICULTURE, STRUCTURAL STEEL WORKS AT BHEL TOWNSHIP-TRICHY
3.	Location of work	BHEL TOWNSHIP -TRICHY
4.	Period of contract	12 months from the date of award of contract.
5.	Earnest Money Deposit	
	Rs. 96,000.00 (RUPEES NINETY SIX THOUSAND ONLY)	MAINTENANCE OF ROAD WORKS AT BHEL TOWNSHIP - PACKAGE-J ₹ 80,00,000.00 (RUPEES EIGHTY LAKH ONLY)
	Rs. 76800.00 (RUPEES SEVENTY SIX THOUSAND EIGHT HUNDRED ONLY)	MAINTENANCE OF WATER SUPPLY & PLUMBING WORKS AT BHEL TOWNSHIP-TRICHY PACKAGE-K ₹ 64,00,000.00 (RUPEES SIXTY FOUR LAKH ONLY)
	Rs. 48,000.00 (RUPEES FORTY EIGHT THOUSAND ONLY)	MAINTENANCE OF HORTICULTURE WORKS AT BHEL TOWNSHIP,TRICHY PACKAGE-L ₹ 40,00,000.00 (RUPEES FORTY LAKH ONLY)
	Rs. 33600.00 (RUPEES THIRTY THREE THOUSAND SIX HUNDRED ONLY)	STRUCTURAL STEEL WORKS AT BHEL TOWNSHIP,TRICHY PACKAGE-M ₹ 28,00,000.00 (RUPEES TWENTY EIGHT LAKH ONLY)
6.	Tender Document details	A] Technical Bid -157 Pages B] Price Bid - 60 Pages
7.	Place of Submission of Tender Document along with EMD& Tender Cost	Sr.Manager, Civil / Planning & Designs, Building 53,GroundFloor, BHEL, High Pressure Boiler Plant, Trichy - 620 014
8.	Pre Bid Meeting	03.05.2018 / 10:00 Hrs at Civil Conference Hall, 53 Building, BHEL, Trichy - 620014
9.	Last Date for Receipt of Tender	15.05.2018 / 10:00 Hrs.
10.	Date of Techno Commercial Bid Opening	15.05.2018 / 10:00 Hrs.
11.	Date of Price Bid Opening/ Reverse Auction	Will be intimated separately to Technically qualified vendors.

CONTRACTOR SHOULD SIGN & STAMP EVERY PAGE (AT RELEVANT PLACES) AS WELL AS IN SUPPORTING DOCUMENTS

A: Contractor Profile

1.	Name of the Agency /Company /vendor.	
2.	Address:	
3.	Phone No.:	
4.	E-mail Address:	
5.	Name and Contact details of person for communication related to Tender	
6.	BHEL Vendor Code (If any)	

B. (QUALIFYING CRITERIA)

Sl. No	Qualifying Criteria	DETAILS			
A	EMD Amount (Offer without EMD & Tender Cost will be rejected.) EMD for every package chosen shall be furnished separately. (Kindly indicate the package name in pencil at the back of DD)	ROAD, WATER SUPPLY & PLUMBING, HORTICULTURE, STRUCTURAL STEEL WORKS AT BHEL TOWNSHIP-TRICHY			
		ROAD WORKS	WATER SUPPLY & PLUMBING	HORTICULTURE	STRUCTURAL STEEL WORKS
		Rs. 96,000.00 (RUPEES NINETY SIX THOUSAND ONLY)	Rs. 76800.00 (RUPEES SEVENTY SIX THOUSAND EIGHT HUNDRED ONLY)	Rs. 48,000.00 (RUPEES FORTY EIGHT THOUSAND ONLY)	Rs. 33600.00 (RUPEES THIRTY THREE THOUSAND SIX HUNDRED ONLY)
		AMOUNT : DD NO: DD DATE: ISSUING BANK :	AMOUNT : DD NO: DD DATE: ISSUING BANK :	AMOUNT : DD NO: DD DATE: ISSUING BANK :	AMOUNT : DD NO: DD DATE: ISSUING BANK :
	Tender Cost (Rs.750) (For all the four or less than four packages)	AMOUNT : DD NO: DD DATE: ISSUING BANK :			
B	Acceptance for Reverse auction	<input type="checkbox"/> Accepted / <input type="checkbox"/> Not Accepted			
C	Income Tax Registration : (Copy of PAN to be attached)				
D	GST Registration (Copy of Registration to be attached)				
E	PF Registration (No. & Date) (Copy of PF Registration to be attached)				
F	ESI Registration (No. & Date) (Copy of ESI Registration to be attached)				

G Technical Competence -					
Firm Experience		ROAD WORKS PACKAGE-J	WATER SUPPLY & PLUMBING PACKAGE-K	HORTICULTURE PACKAGE-L	STRUCTURAL STEEL WORKS PACKAGE M
		Evaluation Value: Rs.48 Lakhs	Evaluation Value: Rs.38.40 Lakh	Evaluation Value: Rs. 24 Lakh	Evaluation Value: Rs.16.80 Lakh
1. Average annual financial turnover of 30% of Evaluation value during the last 3 financial years ending 31-Mar-2017 ie 2014-15,15-16,16-17	Average Annual Turnover (30%)	Rs.14.40 Lakhs	Rs 11.52 Lakhs	Rs 7.20 Lakhs	Rs. 5.04 Lakhs
2. During the last 7 years, ie since 01.04.2011 to 31.03.2018, should have executed works similar to Civil works such as RCC foundations, Construction or maintenance of Residential and Non Residential Buildings / Industrial Buildings) Three similar works for a value of 40% of Evaluation value each (or) b) Two similar works for a value of 50% of Evaluation value each (or) c) One similar work for a value of 80% of Evaluation value Service completion certificates along with work order issued by any Central / State Govt. / PSU company / Private Organization. Experience certificate from private organization to be supported by TDS (Tax Deducted at Source) certificate issued by the organization OR Form 26 AS	Three Similar Work (or) (40%)	Rs.19.20 Lakhs	Rs 15.36Lakhs	Rs 9.60 Lakhs	Rs 6.72 Lakhs
	Two Similar Work (or) (50%)	Rs 24.00Lakhs	Rs 19.20 Lakhs	Rs12.00Lakhs	Rs.8.40 Lakhs
	One Similar Work (80%)	Rs 38.40 Lakhs	Rs 30.72 Lakhs	Rs 19.20Lakhs	Rs 13.44 Lakhs
3.Latest Solvency Certificate(Obtained within 06 Months from the date of tender opening) from Nationalised / Scheduled Bank shall be at least for a value of 40% of the evaluation value	Solvency (40%)	Rs .19.20 Lakhs	Rs.15.36 Lakhs	Rs.9.60	Rs.6.72 Lakh

Note – Each Package is treated separately. Even if applied for more than one packages, value of work experience certificate, Solvency Certificate and turnover as mentioned in above table is required for the one with maximum value. Example, for applying for ROAD WORKS Works and Horticulture Works, the requirement is more for Road works and the certificate to be submitted should meet the Road works requirement.

Similar works for Package J is Any Black topping / Road Patch/Road maintenance works

Similar Works for Package K is Any Pumping Maintenance/plumbing / Pipeline / Water supply oriented works

Similar Works for Package L is Any Garden Maintenance / horticulture oriented works

Similar Works for Package M is Any Structural works like shed / steel structures /Steel Rolling shutter

CIVIL ENGINEERING DEPARTMENT, BHEL, TRICHY-14

H	Financial Soundness: Copy of IT Return acknowledgement, Balance sheet and Profit & Loss statement) during the last three financial years (2014-15, 15-16 & 16-17) i.e duly certified by chartered accountant to be attached		
H.1	Balance Sheet for Financial Year duly certified by chartered accountant	Year	Please Tick (√) in the appropriate box
		2014-15	<input type="checkbox"/> Enclosed / <input type="checkbox"/> Not Enclosed
		2015-16	<input type="checkbox"/> Enclosed / <input type="checkbox"/> Not Enclosed
		2016-17	<input type="checkbox"/> Enclosed / <input type="checkbox"/> Not Enclosed
H.2	Profit & Loss Account for Financial Year duly certified by chartered accountant.	Year	
		2014-15	<input type="checkbox"/> Enclosed / <input type="checkbox"/> Not Enclosed
		2015-16	<input type="checkbox"/> Enclosed / <input type="checkbox"/> Not Enclosed
		2016-17	<input type="checkbox"/> Enclosed / <input type="checkbox"/> Not Enclosed
H.3	Copy of Income Tax submission acknowledgment for Financial Year.	Year	
		2014-15	<input type="checkbox"/> Enclosed / <input type="checkbox"/> Not Enclosed
		2015-16	<input type="checkbox"/> Enclosed / <input type="checkbox"/> Not Enclosed
		2016-17	<input type="checkbox"/> Enclosed / <input type="checkbox"/> Not Enclosed
I	<p>Acceptance Clause :</p> <p>We have read all the terms and conditions, noted the job content & site conditions.</p> <p>We have quoted our offer by taking care of unit of measurement given in the Bill of quantities against individual items</p> <p>We have not taken any deviation from tender clauses as enumerated in the tender and we hereby convey our unqualified acceptance to all terms and conditions as stipulated in the tender. In the event of observance of any deviation in any part of our offer at a later date whether implicit or explicit, the deviations shall stand null & void.</p> <p>We confirm to have submitted our offer strictly in accordance with tender instructions.</p>		<input type="checkbox"/> Accepted / <input type="checkbox"/> Not Accepted

IMPORTANT NOTE: Even though this Notice Inviting Tender consisting four packages of tender schedules, each tender schedule will be dealt separately

1. All the above mentioned documents should be submitted with gazette officer attestation with self-attestation. Original documents should be produced on demand. Documents submitted will be subject to scrutiny at any time .
2. The tenderer should have ESI, EPF, PAN, and GST Registration No. , Acknowledged IT returns, P&L, Balance Sheet and other eligibility criteria documents which will be subject to verification at any time before or after ordering.
3. At the time of submitting offer, if any vendors does not have ESI, EPF NO the vendor should produce a declaration stating that ESI and PF registration will be submitted before placing of Work order / Commencement of Work.
4. Solvency Certificate will be applicable to the tenders whose estimate value is Rs.25 Lakh and above.

SOME COMMON FAQ'S

SOME COMMON FAQ'S REGARDING THIS TENDER HAS BEEN LISTED. VENDORS ARE ADVISED TO CONTACT THE TENDER FLOATING AUTHORITY FOR ANY CLARIFICATION, BEFORE SUBMITTING THEIR OFFER.

1. I Wish to apply for all the Four works. Whether should I furnish 4 sets of qualifying documents for the 4 works?

You need not submit 4 sets of qualifying documents. It is sufficient to submit one set of documents as solicited in the qualifying criteria. However your tender cover should contain

- a) EMD & Tender Cost cover (for 4 works as separate DD's of specified amount- each cover clearly specifying Tender schedule no, name of work applied for and one Tender Cost DD)
- b) Technical bid cover (One technical bid with supporting documents is enough- cover clearly specifying Tender Schedule no and name of work applied for. However, your annual average turnover, Work Experience Certificate and the Solvency certificate should be for the package which requires the maximum value of the 4 packages applied.
- c) Price bid cover (shall contain 4 separately sealed price bids- each cover clearly specifying Tender Schedule no, name of work applied for)

2. I wish to apply for two works. Whether should I furnish 2 sets of qualifying documents for the 2 works?

You need not submit 2 sets of qualifying documents. It is sufficient to submit one set of documents as solicited in the qualifying criteria. However your tender cover should contain

- a) EMD & Tender Cost cover (for 2 works as separate DD's of specified amount-each cover clearly specifying Tender Schedule no, name of work applied for and one Tender Cost DD)
- b) Technical bid cover (One technical bid with supporting documents is enough- cover clearly specifying Tender Schedule no and name of work applied for. However, your annual average turnover, Work Experience Certificate and the Solvency certificate should be for the package which requires the maximum value of the 2 packages applied.
- c) Price bid cover (shall contain 2 separately sealed price bids- each cover clearly specifying Tender Schedule no, name of work applied for)

3. I wish to apply for only one work. How should I furnish qualifying documents ?

You need to submit one set of documents as solicited in the qualifying criteria. Your tender cover should contain

- a) EMD & Tender Cost cover (for required amount as DD - clearly specifying Tender Schedule no, name of work applied for and one Tender Cost DD)
- b) Technical bid cover (One technical bid with supporting documents -cover clearly specifying Tender Schedule no and name of work applied for. Your annual average turnover, Work Experience Certificate and the Solvency certificate should be for the package applied.
- c) Price bid cover (shall contain sealed price bid- clearly specifying Tender Schedule no, name of work applied for)

REVERSE AUCTION CONTACT DETAILS

BHEL reserves the right to go for Reverse Auction (RA)instead of opening the sealed envelope price bid/s, submitted by the bidder. More details given under 'SPECIAL TERMS & CONDITIONS OF CONTRACT'

For this purpose, the following details should be furnished **without fail, along with the offer.**

Name of the contact person assigned for Reverse auction	
Mobile & Land line Number	
E-mail id	
FAX No.(if available)	

BHARAT HEAVY ELECTRICALS LIMITED
TIRUCHIRAPPALLI – 620 014
CIVIL ENGINEERING DEPARTMENT (TOWNSHIP)

PREAMBLE

1. **The scope of work includes ROAD, WATER SUPPLY & PLUMBING, HORTICULTURE, STRUCTURAL STEEL WORKS AT BHEL TOWNSHIP-TRICHY**
2. Time is the essence of the contract. Being a time bound works, the contractor should make all efforts to complete the work in time. Even though the overall completion period is indicated as **12 months**, works shall be completed progressively and handed over as per agreed split up schedule.
3. **The tender value excludes cost of Cement, Reinforcement steel, Structural steel & Rail which will be supplied by BHEL from BHEL Stores at free of cost as indicated in Schedule B of the Tender document.**
4. Tender Value is only approximate and liable for variation without entitling the tenderer to any compensation, till the total value of contract does not vary more than 30%. The contractor has to execute any item of work irrespective of the quantity available in the tender without any reservation till the contract value does not vary more than 30%.
5. The brief description of items of work and respective item rate are given in Bill of quantities of Price Bid . **Tenderer has to quote a common single percentage in page No. 02 to 11 for Package J, in Page No.12 to 38 for Package K, in Page No.39 to 43 for Package L, in Page No.44 to 60 for Package M (participating packages alone shall be Quoted) of Price Bid separately for all the items given in the corresponding bill of quantities (i.e.) below (100-X) % / At par (100%) / Above (100+X) %. Applicable GST shall be extra.**
6. **Quoted percentage rate for all items shall be firm throughout the contract period of 12 (Twelve) months including extended period if any and no cost escalation is allowed on any account.**
7. **BHEL reserves its right to split and award the total work into 60% value for (L1) lowest tenderer, 40% value for the second lowest or other tenderers (priority will be in the order of L2, L3, etc. to accept the L1 rate to award the 40% of the corresponding work), who accepts the rate of L1 for the individual packages whose tender value is more than Rs.25 Lakhs.**
8. **In view of split & award option for the packages having tender value more than 25 Lakhs, the Estimate value shall be considered as 60 % of tender value for evaluation purpose only.—(This concept is applicable to the PACKAGES J,K,L,M of this tender).**
9. **In the event of not getting the second agency for split, owing to the vast difference in the quoted percentage between the lowest and the next, the award procedure will be as follows:
The (L1) lowest agency will be initially awarded for 60% of Estimate Value and on successful completion of the contract, the balance value of (40% of the Estimate Value) of the work shall be enhanced subsequently.**
10. The work is split into number of sub works and sub work orders will be issued to each sub work. Though the period of contract is 12 Months, each sub work must be completed before its completion period as mentioned in its Sub work order.

CIVIL ENGINEERING DEPARTMENT, BHEL, TRICHY-14

11. Some changes are likely in the quantities furnished as well as in the layout, design and specifications of the work. The rates quoted shall be deemed to be inclusive of all such contingencies.

12. Taxes & Duties

The percentage rate offered is for finished item of works as per Bill of quantities attached in the price bid and shall provide for the complete cost towards fuel, tools, tackles, plant & machinery, temporary works, labour, materials, levies, taxes, transport, lay-out, repairs, rectifications, maintenance till handing over, supervision, establishment, services, revenue expenses, overheads, profits & all other incidentals etc., complete Rate quoted shall include all royalties, terminal taxes, Octroi duties, and any other taxes leviable under the State or Central Government rules. The Bharat Heavy Electricals Ltd., will not entertain any claim whatever in this respect.

The percentage rate quoted shall not include applicable GST.

- a. Response to Tenders will be entertained only if the contractor has a valid GST registration no which should be clearly mentioned in the offer.
- b. The Contractor shall mention their GST registration number in all their invoices and invoices shall be in the format as specified/prescribed under GST laws. Invoices shall necessarily contain Invoice number (in case of multiple numbering system is being followed for billing like SAP invoice no, commercial invoice no etc., then the Invoice No which is linked/uploaded in GSTN network shall be clearly indicated), item description as per PO, Quantity, Rate, Value, applicable taxes with nomenclature (like IGST, SGST, CGST & UTGST) separately, HSN / SAC Code, etc.
- c. All invoices shall bear the SAC code (Services Accounting Code) & HSN Code (if applicable) for each item separately (Harmonized System of Nomenclature).
- d. **Payment shall be effected only after submission of declaration to the effect that all invoice particulars are/were uploaded in the GSTN network/ portal & All tax liability as per GST rules and regulations have been and will be discharged, shall be mentioned in the invoice. If it is not mentioned in the invoice, a separate declaration shall be submitted as per the requirement of BHEL.**
- e. All documents like Work completion certificate and any other document mentioned in PO, shall be submitted.

For all works executed within the calendar month, input credit will be availed within that month in line with monthly returns filing cycle (if Input Tax Credit is applicable). In case of any discrepancy in the document or non-submission of documents mentioned in the PO, then BHEL will not be able to accept or account the works executed, in such case availing of tax credit will be deferred to next month or so.

- f. In case of discrepancy in the data uploaded by contractor in the GSTN portal or in case of any shortages or rejection in the works executed, then BHEL will not be able to avail the tax credit (if Input Tax Credit is applicable) and will notify the Contractor of the same. The Contractor has to rectify the data discrepancy in the GSTN portal or issue credit note (details to be uploaded in GSTN portal) for the shortages or rejections, within the calendar month notified by BHEL.
- g. For any such delay in availing of tax credit for reasons attributable to the Contractor (as mentioned above), interest (calculated @ SBI Base Rate + 6%) along with penalty if any will be deducted for the delayed period i.e. from the month of receipt till the month tax credit is availed, from the running bills.

CIVIL ENGINEERING DEPARTMENT, BHEL, TRICHY-14

All taxes and duty other than GST & GST Cess

The contract price shall be inclusive of all (save the specific exclusions as enumerated in this contract) taxes, fees, license charges, deposits, duties, tools, royalty, Octroi, commissions or other charges which may be levied on the input goods consumed and output goods delivered in the course of Works Contract. In case BHEL is forced to pay any of such taxes, BHEL shall have the right to recover the same from the contractors bills or otherwise as deemed fit.

Goods and service Tax (GST) & Cess

The contractor shall submit the proof of GST registration to BHEL at the offer stage. Contractor's price/rates shall be exclusive of GST & GST Cess (if applicable) herein after termed as GST. Contractor shall submit to BHEL the GST compliant tax invoice/debit note/revised tax invoice on the basis of which BHEL will claim the input tax credit in its return (if Input Tax Credit is applicable). GST charged in the tax invoice/debit note/revised tax invoice by the contractor shall be released separately to the contractor only after contractor files the outward supply details in GSTR-1 on GSTN portal and input tax credit of such invoice is matched with corresponding details of outward supply of the supply and has paid the GST at the time of filing the monthly return.

In case of deduction/excess in completion certificate/measurements, credit note /debit note shall be issued within the time limit prescribed in GST law and accordingly contractor shall adjust his tax liability.

If GST will be payable on reverse charge, then the same shall be payable directly to Govt by BHEL under reverse charge.

In case BHEL has to incur any liability (like interest, penalty etc.) due to denial or reversal of input tax credit for the reasons attributable to the contractor or any such delay in availing of tax credit for reasons attributable to the Contractor, the same shall be recovered from the contractor.

In case BHEL is deprived off the Input tax credit due to any reason attributable to contractor, the same shall not be paid to the contractor or will be recovered from the contractor.

TDS under GST (as & when applicable) shall be deducted at prevailing rates on applicable value from the running bills.

New Taxes/Levies - In case the Government imposes any new levy/tax on the output service/ goods/ after price bid opening, the same shall be reimbursed by BHEL at actual.

In case any new tax / levy / duty etc. becomes applicable after the date of Bidder's offer but before opening of the price Bid, the Bidder/Contractor must convey its impact on his price duly substantiated by documentary evidence in support of the same before opening of Price Bid. Claim for any such impact after opening the Price Bid will not be considered by BHEL for reimbursement of tax or reassessment of offer.

13. The tenderers are advised to visit BHEL Township at Tiruchirappalli and get themselves acquainted with the site conditions before submitting the offer.
14. Usually, working hours are limited to day time only. In emergency cases to carryout works during nights, it may be done so with the specific prior permission of BHEL. In such case, it is to be carried out in the presence of BHEL officials or their authorized persons.
15. The value of turnover and the value of similar works mentioned above excludes cost of cement, reinforcement steel and structural steel. However if the turnover value furnished by the tenderer includes

CIVIL ENGINEERING DEPARTMENT, BHEL, TRICHY-14

the above materials, then the tenderer has to furnish the cost of the same separately. If it is not furnished, the materials cost will be presumed as follows: -

Civil & structural works combined	- 50 %
Civil works alone	- 35 %
Structural works including cloaking items	- 70 %
Other minor maintenance works	- 20 %

16. For any item of work not covered in Bill of quantities, the rate will be arrived at based on the conditions given in BHEL General Conditions of Contract in force.

17. The work shall be carried out as per drawings released then and there, AWS / BIS specifications, standard code of practice and as per the instructions of Engineer-in-charge.

18. The percentage rate offered is for finished item of works and shall provide for the complete cost fuel, tools, tackles, plant & machinery, temporary works, labour, levies, taxes, transport, lay-out, repairs, rectifications, maintenance till handing over, supervision, labour colony Establishment, services, revenue expenses, overheads, profits & all other incidentals etc., complete.

19. New Taxes / Levies

In case the Government imposes any new levy / tax on the output service / goods / work after award of the contract, the same shall be reimbursed by BHEL at actual. In case any new tax / levy / duty etc. becomes applicable after the date of Bidder's offer, the Bidder / Contractor must convey its impact on his price duly substantiated by documentary evidence in support of the same **before opening of Price Bid**. Claim for any such impact after opening the Price Bid will not be considered by BHEL for reimbursement of tax or reassessment of offer.

20. After award of work the contractor has to furnish the security deposit, as per Clause 13 of Tender Notice, attached in the Tender Document. Also it is to be noted that after award of work the contractor has to furnish 50 % of security deposit before the commencement of work.

21. For any clarification on the tender document, the bidder may seek the same in writing or through email, as per specified format, within the scheduled date for seeking clarification, from the office of the undersigned. BHEL shall not be responsible for receipt of queries after due date of seeking clarification due to postal delay or any other delays. Any clarification / query received after last date for seeking clarification may not be normally entertained by BHEL and no time extension will be given.

22. The contractor should bring the construction earth moving machineries like Poclair, Paver, Road Roller, JCB etc., as and when required for the work without any delay. Also required number of the following tools & Plants / instruments shall be made available at site for the works as and when required.

- a) Precise Leveling instruments and theodolite.
- b) Full load mixture machine / mini batching
- c) Petrol / Kerosene driven vibrator/ mechanical vibrator
- d) Cube moulds
- e) Inter carting vehicle (tractor, hand trolley etc)
- f) Hydra cranes
- g) Power operated winches
- h) Mobile / Hydraulic crane
- i) Welding machine etc.

CIVIL ENGINEERING DEPARTMENT, BHEL, TRICHY-14

23. The contractor has to arrange sufficient number of lorries to collect & transport the surplus earth, construction debris generated, etc. at site. Otherwise BHEL would clear the debris at the contractor's risk and cost.
24. In the event of any conflict between requirement of any clause of this specification / documents / drawings / data sheets etc. or requirements of different codes/standards specified, the same to be brought to the knowledge of BHEL in writing for clarification before due date of seeking clarification (whichever is applicable), otherwise, interpretation by BHEL shall prevail. Any typing error / missing pages / other clerical errors in the tender documents, noticed must be pointed out before submission of offer, else BHEL's interpretation shall prevail.

25. Order of Precedence

In the event of any ambiguity or conflict between the Tender Documents, the order of precedence shall be in the order below:

- a. Amendments / Clarifications / Corrigenda / Errata etc issued in respect of the tender documents by BHEL
- b. Notice Inviting Tender (NIT)
- c. Price Bid
- d. Qualification Bid
- e. General Conditions of Contract

26. The decision of Engineer-in-charge shall be final and binding on the contractor regarding clarification of items in this tender schedule.
27. **The following eligibility criteria shall be complied to fulfill the Qualification Bid. If the following criteria are not fulfilled, the tender is liable for rejection.**

- A) The tenderer should have ESI, EPF, PAN, GST Registration No., proof of having submitted IT returns acknowledged by IT office, Profit & Loss account and balance sheets certified by the auditor for the three financial years (2014-15, 2015-16 & 2016-17)**
- B) Average Annual financial turnover during the last 3 years, ending 31st March of the previous financial year, should be at least 30% of the evaluation value.**
- C) Experience of having successfully completed similar works during last 7 (Seven) years ending last day of month previous to the one in which applications are invited should be either of the following**
 - I. Three similar completed works costing not less than the amount equal to 40% of the evaluation cost. (or)**
 - II. Two similar completed works costing not less than the amount equal to 50% of the evaluation cost (or)**
 - III. One similar completed works costing not less than the amount equal to 80% of the evaluation cost.**
- D) Latest Solvency certificate (obtained within 6 months from the date of tender opening) from Nationalised / Scheduled Bank shall be at least for a value of 40 % of the evaluation cost.**

Similar Work means either Civil works like RCC foundations, Residential and Non Residential Buildings, RCC water tanks or Maintenance works like Maintenance of Industrial Buildings, residential Quarters, etc

CIVIL ENGINEERING DEPARTMENT, BHEL, TRICHY-14

28. Documentary evidences (Xerox copies – Gazetted officer attested & self-attested) for turnover, works experience, EPF, ESI, GST and Balance sheet (Signed by CA), Profit & Loss account (Signed by CA) & IT returns for the last three years etc., all as required & indicated in the tender document should be furnished, without which it will not be taken into account. The tenderers shall produce original document for verification if so decided by BHEL.
29. The contractor may be required to undertake works at remote places and in such cases the contractor should make own arrangement for safety of BHEL materials, water required for the work and power etc without extra claim from BHEL.
30. The decision of Engineer-in-charge shall be final and binding on the contractor regarding clarification of items in this tender schedule.
31. The works executed in the own name of the tenderer only will be considered for eligibility criteria.. **The nominated committee may also visit the works executed by the contractor / tenderer to ascertain the nature of work relating to similar works before qualifying.**
32. The contractor shall strictly adhere to various labour laws in force.
33. **The tenderer has to ensure payment of Minimum Wages as per Tamil Nadu State Minimum Wages as applicable under law from time to time.**

The labourers engaged in this contract shall be paid additional payment as mentioned below in addition to the payment of Minimum wages as stated above.

a) Unskilled Worker	Rs. 3200 per month
b) Semi-skilled Worker	Rs. 3700 per month
c) Skilled Worker / Supervisor	Rs. 4100 per month

Also the labourers shall be paid a minimum bonus which shall be 8.33% as per the payment of Bonus Act 1965 for the total wages paid (i.e) Payment of minimum wages and additional payment as mentioned above.

The Contractor shall have to remit EPF & ESI contributions at the rates applicable under law to the authorities concerned for the total wages paid (i.e) Payment of minimum wages and additional payment as mentioned above.

At present the Tamil Nadu State Government Minimum wages declared is enclosed for your reference (Ref. Page No.26). Normally the revision will be with effect from 1st April of every year. Tenderers are requested to quote their offer after taking into account of the above factor also.

Contractors should ensure that atleast the Prevailing Tamilnadu State Govt minimum wages applicable to General Engineering and Fabrication Industry and BHEL additional wages inclusive of bonus after remitting PF & ESI contributions, shall be paid to the labourers ONLY in their respective bank account by means of NEFT/ RTGS/ IMPS. Payment done through bank in any of the above modes to the individual labour's bank account should NOT be less than the minimum wages announced by the State Government prevailing on the period of execution of work and BHEL additional wages inclusive of bonus after remitting for PF,ESI and other statutory obligations.

While submitting bills by contractor, the proof of payment made to labours through bank as mentioned above should be furnished along with PF and ESI contribution challans to Welfare Section every month for effecting payment by BHEL. Otherwise payment to the bills will not paid to the contractors. In addition, the contractor has to submit wage register as a proof for payment of

CIVIL ENGINEERING DEPARTMENT, BHEL, TRICHY-14

Minimum wages and additional wages as per prevailing acts, for getting payment from BHEL."

34. The contractor shall ensure compliance of EPF&MP Act 1952, by the subcontractors , if any engaged by the contractor
35. The contractor shall follow norms of BHEL security system for movement of men including bio-metric system & materials within the complex.
- 36. The offers of the tenderer / bidders who are on the banned list and also the offer of the bidders who engage the services of the banned firms, shall be rejected. The list of banned firms is available on BHEL web site (www.bhel.com ---> Tender Notification - List of Banned Firms)**
37. Since the responsibility for the quality, workmanship and accuracy of any work being carried out under this contract lies with the contractor, the contractor should ensure that no work is done without the presence of contractor's representative at the work spot. The contract should arrange for surveying construction site wherever required at his own cost.
38. BHEL reserves its right to reject the offer on account of unsatisfactory past performance by the present tenderer / his group / group of companies / any member in the consortium in case of consortium in another project / sister unit awarded under different enquiry. The tenderer has to declare the facts of performance with his customers and their contact details with phone & e-mail ids in his letter head. BHEL reserves its right to cancel the tender without assigning any reason.
39. Bank Guarantee format and the list of consortium banks are enclosed for BG submission against Security Deposit
40. Tenderers are requested to furnish the duly filled in E format (attached as separate in the Qualification Bid) sheet along with a cancelled cheque leaf to accept Electronic Fund Transfer / R T G S transfer for any payment from BHEL, Trichy.
41. The contractor has to submit the organization chart of their set up for the works and any change thereafter in the organization set up shall have the prior approval of BHEL.
42. The contractor should submit the programme for the completion of work and the list of machineries and site personnel to be deployed for the work along with tender.
43. Statement of completed works with detailed measurements along with material reconciliation statements shall be submitted by the contractor in the last week of every month for processing bill.
44. The contractor should establish his own site office, labour colony, fabrication yard, handling facility, storage facility for cement etc., for which vacant land will be allotted on specific request for which the rent will not be collected.
45. The contractor is required to carry out construction activities as directed by the department officials. It is required to engage certain minimum strength of staff for effective supervision of works as indicated below for individual Tender Schedules:

For CT:TS:012/18-19 (Road Maintenance Works):

Minimum Site Engineer and Co-ordinator - 1 No.
Minimum Supervisor/Engineer (Diploma Holder) - 3 Nos.

For CT:TS:013/18-19 (Water Supply Works):

Minimum Site Engineer and Co-ordinator - 1 No.
Minimum Supervisor/Engineer (Diploma Holder) - 2 Nos.

CIVIL ENGINEERING DEPARTMENT, BHEL, TRICHY-14

For CT:TS:014/18-19 (Horticulture Works):

Minimum Site Engineer and Co-ordinator - 1 No.

Minimum Supervisor/Engineer (Diploma Holder) - 1 No.

For CT:TS:015/18-19 (Structural Works):

Minimum Site Engineer and Co-ordinator - 1 No.

Minimum Supervisor/Engineer (Diploma Holder) - 1 No.

In addition to the above, Quantity surveyors have to be engaged to prepare measurements and submit the bills.

Adequate number of Quality Engineer and qualified Safety Engineer should be deployed at site. Experienced Engineers / Supervisors are to be engaged in Railway and water supply works.

46. The tenderer has to deploy adequate labour of required categories such as Unskilled, Skilled, Mason, Carpenter, Plumber, Welder, Fitter, Mistry, Technically experienced, etc. so as to execute the works simultaneously in all areas of work. The Technical persons with experience shall have to produce valid certificate for verification.
47. Expertise labour only to be engaged for specialized items of work like laying of ceramic tiles, marbles, cuddapah slabs, granite slabs and false ceiling, partition, wall paneling, architectural finishing etc. and work experienced persons shall be engaged for fabrication, water supply, railway track laying and aligning works, sewerage system work, etc.
48. Exclusive Stores personnel should be engaged who would co ordinate with department official for clearance and collection of BHEL supplied materials required for works. Separate non-technical persons should be engaged for arranging daily gate passes for labours and vehicles entry in all the gates of Factory Complex.
49. The works contract to be entered into with the successful tenderer will be governed by the BHEL Revised General Conditions of Contract in force.
50. All the works shall be executed as per the standard specifications as provided in TNBP / BIS and special specifications of manufacturer.
51. All the materials to be used in the work and the nature of work shall conform to the respective TNBP & BIS and National Building Organization, Standard Specifications forming part of "ALL INDIA STANDARD SCHEDULE OF RATES" specifications and shall be got approved by the Engineer-in-charge before actual incorporation in the work.
52. With regard to specifications not covered by the General and Special Conditions of Contract, those contained in the Tamil Nadu Building Practice Standard Specifications or other specifications approved by Bharat Heavy Electricals Limited, shall apply.
- 53. The contractor should use only the materials of brand and quality as approved by BHEL.**
54. All materials and consumables brought by the contractor should have manufacturer's certificate.
55. All materials brought by the Contractor for incorporation in the work shall be got inspected and approved by the Engineer-in-charge before they are incorporated in the work.
56. The contractor should use only weigh batch for all reinforced cement concrete works (controlled concrete). The tenderer is advised to install concrete mini batching plant at site considering the quantum of concrete work involved.

CIVIL ENGINEERING DEPARTMENT, BHEL, TRICHY-14

57. The contractor should submit the mix design for RCC for different mix of concrete for different grade of cement at his cost through reputed institution.
58. The contractor should maintain proper accounts for cement, reinforcements, Structural steel and other materials if any supplied by this organization and these should be available at the site of work for verification and check by the Officials of this Organization at any time.
59. Contractor's materials and tools & plants shall have to be brought inside Township with proper invoice / voucher and make necessary entry in the security gate. They should maintain proper record for tools and plants, materials, etc., brought inside the Township complex.
60. All tools and plants including jack hammer with silencer & bits, rock drilling machine, etc., required for all the works covered under this contract will have to be brought by the contractor. Compressed air alone will be provided at viable locations at free of cost by BHEL. From that point the contractor has to provide further arrangements for site works.
61. To safeguard the persons working at height in roof, wall etc., sufficient number of Industrial Safety nets shall be provided at tenderer's cost in appropriate level and locations. The working hand including Supervisors, Engineers should wear the personal protective items and safety measures such as helmets, safety belts, shoes, etc., before entering into working place.
62. All safety measures are to be followed during execution of work, particularly during blasting and only licensed blaster should be engaged for this purpose. Sufficient care shall be taken by the contractor during excavation to avoid damages to the buried pipe lines, cables and other infrastructure like railway lines if any etc. Controlled blasting including muffling can be carried out with prior permission from safety department.
63. The tenderer shall carry out health performance test at his cost for all the workmen engaged in the work through a registered medical practitioner and produce certificate on demand.
64. It shall be the responsibility of the contractor to see that the workmen do not utilize the departmental canteen facilities. Contractor has to make his own arrangements to provide refreshment for the workmen.
65. The contractor should extend fullest co-operation with the third party agencies engaged, if any by BHEL to adhere the Quality Control Procedures ensuring quality.
66. The contractor should extend full co-operation to the other contractors who may be doing other works in the same areas to enable them to execute their portions of work without any delay or difficulty.
67. On the written request from the contractor **Water required for the work may be provided by this organization at only one point at the site of the work at free of cost.** In case of failure of water supply, the Contractor will have to make his own arrangements for water without any extra claims until supply is restored. BHEL does not accept any liability whatsoever for non-supply or delay in the supply of water under any circumstances. The contractor shall ensure that there is no wastage of water otherwise supply of water is liable to be stopped at contractor's risk and cost.
68. On the written request from the contractor **Electrical energy required for the work may be given by this organization at any one point at the site of work at free of cost.** BHEL does not accept any liability whatsoever for non-supply, delay in supply or failure of supply of electrical energy. Contractor shall ensure that there is no wastage of electrical energy otherwise supply is liable to be stopped at contractor's risk and cost. The contractor shall make leak proof / fire proof shed and provide control panel board of required capacity and lay the required cables at their own cost for further distribution.

CIVIL ENGINEERING DEPARTMENT, BHEL, TRICHY-14

69. On the written request from the contractor **Compressed air for the work will be provided by this organization at only one point near the site of work at free of cost.** The contractor should be in a position to make his own arrangement for compressed air without any extra claim for the uninterrupted operation of jackhammer with silencer wherever BHEL is not in a position to supply compressed air.
70. **Bank Guarantee format can be obtained after award of work by the successful tenderer.**
71. Field quality plan issued by BHEL should be strictly followed.
72. No night work will be permitted without the written permission of the Engineer – in – charge.
73. Bulkage test on the sand to be used on the work should be conducted periodically to arrive at the correct quantity of sand to be mixed for the different proportions as and when required.
74. Tenderers are requested to furnish the duly filled in E format attached **with this** as separate sheet along with a cancelled cheque leaf to accept Electronic fund transfer / R T G S transfer for any payment from BHEL, Trichy.
75. No advance / No mobilization advance will be given and the part-payment or advance for raw materials brought by the successful tenderer will not be paid. The payment for the finished items of works only will be paid after incorporating the required raw materials into the work, if any.
76. Misuse of the building (residential/non-residential) taken for maintenance viz. not closing water tap / not switching off power / not closing the main door at the end of the day will attract a fine of Rs.500/- per occasion.
77. Any mixing of concrete or cement mortar directly on the road surface will attract a fine of Rs.1000/-.
78. Items of work other than those mentioned in bill of quantities attached with Pride bid will be carried out at the rates to be fixed by this organization as per relevant clauses of the General Conditions of Contract.
79. No Over Run Charges shall be applicable under any circumstances.
80. LD / Penalty clause is applicable as per General Conditions of Contract in force.
81. BHEL reserves its right to finalize the contract through reverse auction for which only qualified tenderers will be provided with necessary documents containing reverse auction rules, terms and conditions for this purpose.
82. In all matters of dispute, the decision of General Manager BHEL, Tiruchirappalli 620 014 is final and binding on the successful tenderer
83. Any claim or dispute arising from the tender stage, till/after completion of the work under the terms and conditions stipulated in the tender document/contract agreement shall only be enforced or settled in the courts at Tiruchirappalli, TamilNadu only.
84. **Force Majeure clause:** If at any time during the continuance of this contract the performance in whole or in part by either party of any obligations under this contract shall be prevented or delayed by reason, of any war, hostilities, acts of the public enemy, civil commotion, sabotage, fires, explosions, epidemics, quarantine, restrictions or acts of GOD (hereinafter referred to as events) then provided notice of happening of any such events is given by either party to other within twenty one days from the date of

CIVIL ENGINEERING DEPARTMENT, BHEL, TRICHY-14

occurrence thereof neither party shall reason of such events be entitled to terminate this contract nor shall either party have any such non performance and delay is resumed as soon as practicable after such events has come to an end or ceased to exist. If the performance in whole or part of any obligation under this contract is prevented or delayed by reason or any such event claims for extension of time shall be granted for period considered reasonable by BHEL subject to prompt notification by the tenderer to BHEL of the particulars of the events and supply to the BHEL if required of any supporting evidence. Any waiver of time in respect of partial installment shall not be deemed to be a waiver of time in respect of remaining deliveries.

85. The correspondence exchanged against the tender from both tenderer and BHEL through email are considered as valid document legally though it is not signed. It is treated as valid confirmations made on behalf of the respective company and very much comes under the legal ambit of the business transaction and hence it is binding on both the parties to the business.
86. Any transaction pertaining to the tender from both the parties of business done round the clock irrespective of the office or business hours of the companies, are valid legally and binding on both the parties. This applies to the extent only in such cases where deadline time for transaction is not specifically declared by either or both the parties to the business.
87. In case Letter of Intent (LOI) is issued through email, the PC generated time and date of mail shall be construed as the official time and date of release of LOI. In as much as this date is within the last date of validity given by the bidder the LOI is said to have been issued within the validity period and shall be binding on both the parties to the business.
88. Tenderers participating in the tender should declare in their technical bid that whether they have been black-listed / kept on hold for a specified period / given Business holiday for a specified period by any Public sector undertaking or Government departments. The reasons for such action with details and the current status of such hold shall be clearly furnished to BHEL. If no such details are mentioned in the offer then it will be construed that the subject bidder is not under any such hold. But at a later date if it comes to the notice of BHEL about any such hold under enforcement on the subject bidder, BHEL will have every right to reject the offer of such vendors at any point of time and also under any stage of the finalisation of the subject tender irrespective of the status of the subject bidder in that tender. Such bidders will not be permitted to participate in the further tender proceedings and will be communicated suitably. They will not be also considered for any on going tenders even if participated till the hold is officially lifted and confirmed in writing.
89. If, in case of opening of price bids, when there is a Tie in the percentage rates quoted by the tenderers, the ranking will be decided based on Lot System, in the presence of the bidders who witness the price bid opening.
90. The bidder along with its associate/ collaborators / sub contractors / sub vendors / consultants / service providers shall strictly adhere to BHEL fraud prevention Policy displayed on BHEL website <http://www.bhel.com> and shall immediately bring to the notice of the management about any fraud or suspected fraud as soon as it comes to their notice

91. Deviations

The contractor shall not make any alteration in addition to or omission from the work as described in the tender documents except in pursuance of the written instructions of the Engineer-in-charge. No such deviation from the work described in the tender documents shall be valid unless the same has been specifically confirmed and accepted by the Accepting Officer in writing and incorporated in the contract.

CIVIL ENGINEERING DEPARTMENT, BHEL, TRICHY-14

The Accepting Officer may deviate either by way of addition or deduction, from the work so described, provided that the contract sum be not thereby varied on the whole by more than the percentage set out in the tender documents. The value of all addition and deductions will be added to, or deducted from the contract sum. Whenever the Accepting Officer intends to exercise such a right, his intention shall specify the deviations which are to be made, the lumpsum assessment or the proposed basis of payment, the extra time allowed, if any, and the date for completion of the entire contract.

Any objection by the Contractor to any matter concerning the order shall be notified by him in writing to the Engineer-in-charge within **Seven days** from the date of such order, but under no circumstances shall the work be stopped (unless so ordered by the Engineer-in-charge) owing to differences or controversy that may arise from such an objection. In the absence of such a notification of objection by the contractor, he will be deemed to have accepted the order and the conditions stated therein. In the event of the contractor failing to agree with the Engineer-in charge regarding the terms of the proposed deviation, the objection shall be referred to the Project Manager whose decision shall be final conclusive and binding on the Contractor.

92. ARBITRATION & CONCILIATION

Except where otherwise provided for in the contract all questions and disputes relating to the meaning of the specifications, designs, drawings and instructions hereinbefore mentioned and as to the quality of workmanship or materials used on the work or as to any other question, claim, right, matter or thing whatsoever in any way arising out of or relating to the contract, designs, drawings, specifications, estimates, instructions, orders or these conditions or otherwise concerning the work or failure to execute the same whether arising during the progress of the work or after the completion or abandonment thereof shall be referred to the sole arbitration of the Executive Director / General Manager of BHEL and if ED is unable or unwilling to act, to the sole arbitration of some other person appointed by the ED / General Manager, willing to act as such arbitrator. The cases referred to arbitration shall be other than those for which the decision of the Manager / Senior Engineer / Engineer-in-charge is expressed in the contract to be final and conclusive.

There will be no objection if the arbitrator so appointed is an employee of B.H.E.L and that he had to deal with the matters to which the contract relates and that in the course of his duties as such he had expressed views on all or any of the matters in dispute or difference.

The arbitrator to whom the matter is originally referred being transferred or vacating his office or being unable to act for any reason, such Executive Director / General Manager as aforesaid at the time of such transfer, vacation of office or inability to act, shall appoint another person to act as arbitrator in accordance with the terms of the contract. Such person shall be entitled to proceed with the reference from the stage at which it was left by his predecessor.

Subject as aforesaid the provision of the Arbitration & Reconciliation Act, 1996 or any statutory modification or re-enactment thereof and the rules made there under and for the time being in force shall apply to the arbitration proceeding under this clause.

It is a term of the contract that the party involving arbitration shall specify the dispute or disputes to be referred to arbitration under this clause together with the amount or amounts claimed in respect of each such dispute.

The arbitrator(s) may from time to time with consent of the parties enlarge the time for making and publishing the award.

CIVIL ENGINEERING DEPARTMENT, BHEL, TRICHY-14

The work under the Contract shall, if reasonably possible, continue, during the arbitration proceedings and no payment due or payable, to the Contractor shall be withheld on account of such proceeding.

The Arbitrator shall be deemed to have entered on the reference on the date he issues notice to both the Parties fixing the date of first hearings.

The arbitrator shall give a separate award in respect of each dispute or difference referred to him.

The venue of arbitration shall be such place as may be fixed by the Arbitrator in his sole discretion.

The award of the arbitrator shall be final, conclusive and binding on all parties to this contract.

In the event of disputes or differences arising between one public sector enterprise and a Govt. Department or between two public sector enterprises the above stipulations shall not apply the provisions of BPE office memorandum No. BPE/CL 001/ 76MAN / 2 (1.10) 75-BPE (GM-1) dated 1st January 1976 or its amendments for arbitration shall be applicable.

Except as provide elsewhere in this contract, in case amicable settlement is not reached between the parties, in respect of any dispute or difference ; arising out of the formation ,breach ,termination ,validity or execution of the contract; or ,the respective rights and liabilities of the parties ; or, in relation to interpretation of any provision of the contract; or , in any manner touching upon the contract, then, either party may, by a notice in writing to the other party refer such dispute or difference to the sole arbitrations of an arbitrator appointed by Head of the BHEL Unit /Region/Division issuing the contract .

The arbitrator shall pass a reasoned award and the award arbitrator shall be final and binding upon the parties.

Subject as aforesaid , the provisions of arbitration and conciliation Act 1996 (India) or statutory modification or re-enactments thereof and the rules made thereunder and for the time being in force shall apply to the arbitration proceedings under the clause .The seat of arbitration shall be Tiruchirapalli , Tamil Nadu

The cost of arbitration shall be borne as per the award of the Arbitrator.

Subject to the arbitration in terms of clause, the Courts at Tiruchirapalli , Tamil Nadu Shall have Exclusive jurisdiction over any matter arising out of or in connection with this Contract.

Notwithstanding the existence or any dispute or differences and / or reference for the arbitration, the Contractors shall proceed with and continue without hindrance the performance of its obligation under this Contract with due diligence and expedition in a professional manner expect where the contract has been terminated by either party in terms of this Contract.

In case of contract with public sector enterprise (PSE) or a Government department, the following shall be applicable:

In the event of any dispute or difference relating to the interpretation and application of the provisions of the Contract, such dispute or difference shall be referred by either party for arbitration to the sole arbitrator in the Department of public Enterprises to be nominated by the Secretary to the Government of India in-charge of the Department of public Enterprises. The arbitration and conciliation Act, 1996 shall not be applicable to arbitration under this clause. The award of the arbitrator shall be binding upon the parties to the dispute ,provided, however, any party aggrieved by such award may make further reference for setting aside or revision of the award to the law secretary, department of legal affairs ,ministry of law and justice, Government of India. Upon such reference the dispute shall be decided by the law secretary or the special secretary or Additional secretary when so authorized by the law secretary, whose decision

CIVIL ENGINEERING DEPARTMENT, BHEL, TRICHY-14

shall bind the parties hereto finally and conclusively . The parties to the dispute will share equally the cost of arbitration as intimated by the arbitrator.



CIVIL ENGINEERING DEPARTMENT, BHEL, TRICHY-14

**BHARAT HEAVY ELECTRICALS LIMITED
TIRUCHIRAPPALLI – 14
HUMAN RESOURCE MANAGEMENT**

CIRCULAR

No. BHEL: HR: WEL: MW

Date: 03.02.2018

ALL CONTRACT EXECUTING/AWARDING OFFICIALS

Sub. : Minimum Wages Act 1948 – Fixation of Minimum rates of wages for the employment in “General Engineering and Fabrication Industry” – Reg.

Ref. : Tamil Nadu Gazette No. 1 dated 03.01.2018

Consequent upon the changes in the Basic Wages and Dearness Allowances payable under the Minimum Wages Act to those employed in “General Engineering and Fabrication Industry”, the Minimum Wages payable by the Contractors to their workmen engaged in the following categories would be as follows with effect from 01/01/2018:

Sl. No.	Category	Minimum Basic Wages per day	Minimum DA per day	Total Minimum Wages per day	Minimum Basic Wages per month	Minimum DA per month	Total Minimum Wages per month
1	Unskilled Worker	Rs.258.50	Rs.163.00	Rs.421.50	Rs.7755.00	Rs.4235.00	Rs.11990.00
2	Semi-Skilled Worker	Rs.271.00	Rs.163.00	Rs.434.00	Rs.8130.00	Rs.4235.00	Rs.12365.00
3	Skilled Worker	Rs.278.50	Rs.163.00	Rs.441.50	Rs.8355.00	Rs.4235.00	Rs.12590.00
4	Supervisor				Rs.7660.00	Rs.4235.00	Rs.11895.00

Contract Awarding / Executing Executives are requested to instruct contractors about the above changes in the Tamil Nadu Government Minimum Wages.

SDGM (HR-Welfare and Recruitment)

Cc:
DGM/HR/PC/Chennai
DGM/HR/PPPU/Thirumayam
AGM/Finance
GM/Finance
AGM/HR
GM/HR

KRISHNAVENI SEKAR
Sr. DGM (HR - Welfare & Recrt.)
Bharat Heavy Electricals Limited
Tiruchirappalli - 620 014.

Guidelines for Suspension of Business Dealings with Suppliers/ Contractors

PREAMBLE

In order to protect the commercial interests of BHEL, it becomes necessary to take action against suppliers/ contractors by way of suspension of business dealings, who either fail to perform or are in default without any reasonable cause, cause loss of business/ money/ reputation, indulge in malpractices, cheating, bribery, fraud or any other misconduct or formation of cartels so as to influence the bidding process or influence the price etc. Suspension of Business Dealings could be in the form of "Hold" or "Banning" a supplier/ contractor or a bidder or an applicant for registration as a registered supplier. For this purpose, the following guidelines shall be followed across all BHEL units/ divisions/ regions (here in after referred to as Units). These guidelines are not exhaustive but enunciate broad principles governing action against such suppliers/ contractors.

SCOPE

- a. For the purposes of these Guidelines, Company means the Bharat Heavy Electricals Limited.
- b. These Guidelines will be applicable to Supplier (which will include vendors, suppliers and contractors) i.e. to say:
 - i. An entity that has applied for registration in any Unit of the Company for any material/service category.
 - ii. A bidder in a tender notified by the Company;
 - iii. An entity which has been awarded a contract.

Note: The term "Tender" or "Contract" referred to in sub-clause (ii) and (iii) as above, refers to tender or contract notified or awarded, as the case may be, by the Company.
- c. Any action under these Guidelines shall be without prejudice to all remedies available under the contracts with the Suppliers or other legal provisions.
- d. If a Supplier, who has participated in a tender/ entered into a contract with BHEL as an Agent/ Trader/ Dealer/ Stockist/ Distributor/ Channel partner etc. (hereinafter referred to as Agent) of an identified Principal/ OEM/ Mills/ Works/ Plants (hereinafter referred to as Principal) for that bid/ contract, then action as per these guidelines can be undertaken against the Principal as well as Agent as appropriate.
- e. In case of the supplier being a Sole Proprietorship firm or a Partnership firm, action under these Guidelines shall be taken against both
 - i. The Sole Proprietorship firm and the Sole Proprietor; or, as the case may be;
 - ii. The Partnership firm and all the partners thereof.

Accordingly, action will be taken under these guidelines against any other Sole Proprietorship firm owned by the same Sole Proprietor. Similarly action under these guidelines will also be taken against another Partnership firm comprising of the same or some of the same Partners (but not including any new Partner) or a Sole Proprietorship firm owned by the same Partner(s).

f. In respect of consortiums and unincorporated Joint Ventures/ Association of Persons (AOP)/ Body of Individuals (BOI), action under these guidelines shall be taken against the defaulting consortium partners and defaulting members of the unincorporated Joint ventures/ Association of Persons (AOP)/ Body of Individuals (BOI).

1.0 Suspension of business dealing with Suppliers

CIVIL ENGINEERING DEPARTMENT, BHEL, TRICHY-14

The following category of suspensions have been provided in these guidelines depending upon the gravity of the omission or commission by the Supplier.

- a) Hold within the unit for specific item(s)/ material category(ies)/ type of work(s) for one year.
- b) Hold within the unit for all item(s)/ material category(ies)/ type of work(s) for two years
- c) Banning across BHEL for all items/ material category(ies)/ type of work(s) for three years.

The Supplier may be either put on hold or banned, as detailed hereinafter on the basis of one or more of the category wise reasons as enumerated hereunder:

1.1 Hold

1.1.1 Hold within the unit for a specific item(s)/ material category(ies)/ type of work(s) shall be imposed in the following cases, if

- I. in the last three consecutive supplies of a specific material category, average quality rating, as provided in the supplier performance rating (SPR) as per SEARP, falls below 80% of the quality weightage. This is irrespective of supplies against PO(s) having single/ multiple delivery schedules.

Note: Not applicable in cases for erection works of Power Sector Regions, where separate guidelines for evaluation of capacity of bidders is being followed.

- II. Two consecutive delays, for reasons of delay attributed to the Supplier, in execution of the contracts where delay occurred is such that
 - a) prescribed maximum LD time limits of the contracts is exceeded or
 - b) delay period has equaled/ exceeded half the original delivery period specified in the contracts whichever among the above is earlier.
- III.
 - a) Overall SPR (Supplier Performance Rating) in that particular Unit in line with SEARP falls below 60% of the specific material category.
 - b) Bids of contractors (in PS-MSX portal) shall not be considered (if average score of last six months falls 60% or below as per guidelines for evaluation of capacity of bidders formula).

Note: – for (b), No specific period of hold shall be applicable.

- IV. Supplier works are under strike/ lockout for a period of more than three months.

1.1.2 Hold within the unit for all item(s)/material category(ies)/ type of work(s) shall be put in the following cases, if

- i) Supplier tampers with tendering procedure affecting ordering process.
- ii) Supplier has misused BHEL documents/ drawings/ technical information or has breached the confidentiality agreement with BHEL.
- iii) after placement of order, Supplier fails to execute the contract.

CIVIL ENGINEERING DEPARTMENT, BHEL, TRICHY-14

- iv) within warranty period as per contract, Supplier continues to supply low/ less/ non-performing equipment/ services, repetitive failures, remains non-responsive.
- v) Wherever risk purchase clause (amounting to more than 5% of contract value) has been invoked.

1.2 Banning across BHEL shall be imposed in following cases, if

1.2.1

- i) After price bid opening but before placement of order, Supplier withdraws his offer or varies it in any manner within the validity period.
- ii) Supplier is found to be responsible for submitting fake/ false/ forged documents, certificates, or information or misrepresentation/ wilful suppression of facts, or has resorted to unethical, illegal means.
- iii) In spite of warnings, the Supplier persistently violates or circumvents the provisions of labour laws/ regulations/ rules or other statutory requirements.
- iv) Supplier is found to be involved in cartel formation or in any other act so as to influence the bidding process or influence the price.
- v) The Supplier has indulged in malpractices or misconduct such as bribery, corruption and fraud, pilferage, coercion etc.
- vi) The Supplier is found guilty by any court of law for criminal activity/ offences involving moral turpitude in relation to business dealings.
- vii) Supplier is found to have obtained any internal information/ documentation of BHEL by unauthorized means.
- viii) The foreign Principals along with the representing Agent shall be banned together if information submitted by them about their precise relationship, commission/ remuneration etc. payable/ receivable and other particulars as asked by BHEL, as per the extant guidelines regarding dealing with Agents of Foreign Suppliers is found false/ incorrect, at any stage.
- ix) Supplier has substituted, damaged, failed to return, or unauthorizedly disposed off free issue materials/ tools etc. of BHEL.

1.2.2 A Supplier can also be banned with the approval of Director (E, R&D) provided a direction to this effect has been received from the administrative ministry of the Government.

2.0 Reason(s) for putting a Supplier under hold/ ban as above are only illustrative and not exhaustive. Depending upon the gravity, the competent authority may decide to put a Supplier under hold/ ban for any other adequate and sufficient reason.

3.0 Procedure

3.2) If prima-facie evidence or sufficient grounds exist for suspension, a 'show-cause notice' shall be issued to the Supplier giving a notice period of 15 days.

3.4) Interim Suspension:

CIVIL ENGINEERING DEPARTMENT, BHEL, TRICHY-14

In appropriate cases for justifiable reasons, fresh enquiries (including consideration of existing offers) can be stopped by the Unit from the date of issue of show-cause notice pending final decision. In case a Supplier submits a representation requesting for lifting of the Interim Suspension, then, the same shall be considered.

Note: Amongst others, in cases where recommendation for suspension of a supplier has been received from CBI/ Vigilance or any other investigating agency or the cases covered under clause 1.1.1 i), the supplier may be immediately put on Interim Suspension for all fresh enquiries in the concerned unit pending final decision.

3.6) If no response to the show cause notice is received from the Supplier within 15 days, BHEL may decide to recommend suspension of business dealings or otherwise on the basis of the available evidence on record.

3.7) If the Supplier responds, BHEL will consider the reply.

3.8) Personal hearing would be provided to the Supplier, if so requested by the Supplier or if so required. The minutes of the discussions shall be signed immediately with the supplier after conclusion of such discussions. In case, the supplier does not sign the minutes or, as the case may be, does not attend the personal hearing, then, record notes of discussion shall be issued to the Supplier on the same day duly recording such facts.

3.10) In case more than one act or omission is alleged to have been committed by the Supplier, then, the case shall be dealt with for all such acts or omissions together as a case of higher category of suspension (as applicable). The suspension to be imposed on the Supplier will be as per the highest category of act or omission that is/are established ultimately.

3.11) The onus shall be with the Supplier to inform BHEL regarding the corrective/ preventive actions taken to address the reasons which has led to its suspension and the hold/ ban will not be lifted automatically after the period mentioned in the order.

Note: In cases of Fraud (as defined in the Fraud Prevention Policy available at www.bhel.com), unit may also consider appropriate action as per BHEL's Fraud Prevention Policy. In addition, if misappropriation/ forgery is established, unit to consider filing of police complaint/FIR.

4.0 The suspension order shall become effective from the earlier of the following events:

a) the date of its issuance;

Or,

b) In case fresh enquiries have been put on Interim Suspension as stipulated in para 3.4 then, from the date when the Interim Suspension was implemented.

5.0 Contractual obligations:

5.1 Treatment of Contracts with Suppliers in Hold cases (applicable for the user unit only):

5.1.1 Contracts already entered into with a Supplier before the date of issue of the order of Hold shall not be affected.

5.1.2 Depending upon the type of hold, in ongoing cases where Techno-commercial Bids are under evaluation and any of the participant Supplier has been put on Hold, then the tender may be processed excluding the bid of

CIVIL ENGINEERING DEPARTMENT, BHEL, TRICHY-14

that Supplier. However, if Price Bid has been opened and that Supplier happens to be L-1, then re-tendering is to be resorted to, excluding the Supplier.

5.1.3 The case of running framework agreement (FA) where multiple POs are placed against a single FA and if the Supplier has been put on hold, further purchase orders against this FA are not to be placed on the Supplier during the period of hold depending on the type of hold.

5.2 Treatment of Contracts with Suppliers in Ban cases (applicable across BHEL):

5.2.1 All existing contracts with the banned Supplier shall normally be terminated by BHEL. Once the order for banning is passed, existing offers/ new offers of the Supplier shall not be entertained.

6.0 Lifting of Suspension

Lifting of suspension will not be automatic on completion of specified period as causes for putting on suspension should be removed/ addressed before lifting of suspension. The Supplier, under suspension may submit explanations to the initiating unit regarding corrective/ preventive actions taken by him.

9.0 List of banned Suppliers shall be hosted on BHEL's website.

12.0 Registration of banned supplier shall be deemed to have been cancelled automatically. Supplier once banned shall have to seek fresh registration in the respective BHEL unit(s) on lifting of ban.

REVERSE AUCTION GUIDELINES

BHEL reserves the right to go for a Reverse Auction (RA) instead of Opening the submitted sealed bid, which will be decided after technical evaluation. Information and general terms and conditions governing RA are given below.

GENERAL TERMS AND CONDITIONS OF RA

Against this enquiry for the subject item/ system with detailed scope of supply as per enquiry specifications, BHEL may resort to "REVERSE AUCTION PROCEDURE" i.e., ON LINE BIDDING (THROUGH A SERVICE PROVIDER). The philosophy followed for reverse auction shall be English Reverse (No ties).

1. For the proposed reverse auction, technically and commercially acceptable bidders only shall be eligible to participate.
2. Those bidders who have given their acceptance for Reverse Auction (quoted against this tender enquiry) will have to necessarily submit „online sealed bid“ in the Reverse Auction. Non-submission of „online sealed bid“ by the bidder for any of the eligible items for which techno-commercially qualified, will be considered as tampering of the tender process and will invite action by BHEL as per extant guidelines in vogue.
3. BHEL will engage the services of a service provider who will provide all necessary training and assistance before commencement of on line bidding on internet.
4. In case of reverse auction, BHEL will inform the bidders the details of Service Provider to enable them to contact & get trained.
5. Business rules like event date, time, bid decrement, extension etc. also will be communicated through service provider for compliance.
6. Bidders have to fax the Compliance form (annexure IV) before start of Reverse auction. Without this, the bidder will not be eligible to participate in the event.
7. In line with the NIT terms, BHEL will provide the calculation sheet (e.g., EXCEL sheet) which will help to arrive at "Total Cost to BHEL" like Packing & forwarding charges, Taxes and Duties, Freight charges, Insurance, GST for Services and loading factors (for non-compliance to BHEL standard Commercial terms & conditions) for each of the bidder to enable them to fill-in the price and keep it ready for keying in during the Auction.
8. Reverse auction will be conducted on scheduled date & time.
9. At the end of Reverse Auction event, the lowest bidder value will be known on auction portal.
10. The lowest bidder has to fax/e-mail the duly signed and filled-in prescribed format for price breakup including that of line items, if required, (Annexure VII) as provided on case-to-case basis to Service provider within two working days of Auction without fail.
11. In case BHEL decides not to go for Reverse Auction procedure for this tender enquiry, the Price bids and price impacts, if any, already submitted and available with BHEL shall be opened as per BHEL's standard practice.
12. Bidders shall be required to read the "Terms and Conditions" section of the auctions site of Service provider, using the Login IDs and passwords given to them by the service provider before reverse auction event. Bidders should acquaint themselves of the

CIVIL ENGINEERING DEPARTMENT,BHEL,TRICHY-14

„Business Rules of Reverse Auction“, which will be communicated before the Reverse Auction.

13. If the Bidder or any of his representatives are found to be involved in Price manipulation/ cartel formation of any kind, directly or indirectly by communicating with other bidders, action as per extant BHEL guidelines, shall be initiated by BHEL and the results of the RA scrapped/ aborted.

14. The Bidder shall not divulge either his Bids or any other exclusive details of BHEL to any other party.

15. In case BHEL decides to go for reverse auction,**the H1 bidder (whose quote is highest in online sealed bid) may not be allowed to participate in further RA process.**

16.BHEL reserves the right to go for Reverse Auction (RA) (Guidelines as available on www.bhel.com) instead of opening the sealed envelope price bid, submitted by the bidder. This will be decided after techno-commercial evaluation. Bidders to give their acceptance with the offer for participation in RA. Non-acceptance to participate in RA may result in non consideration of their bids, in case BHELdecides to go for RA.

17.Those bidders who have given their acceptance to participate in Reverse Auction will have to necessarily submit ‘Process compliance form’ (to the designated service provider) as well as ‘Online sealed bid’ in the Reverse Auction. Non-submission of ‘Process compliance form’ or ‘Online sealed bid’ by the agreed bidder(s) will be considered as tampering of the tender process and will invite action by BHEL as per extant guidelines for suspension of business dealings with suppliers/ contractors (as available on www.bhel.com).

18.The bidders have to necessarily submit online sealed bid less than or equal to their envelope sealed price bid already submitted to BHEL along with the offer. The envelope sealed price bid of successful L1 bidder in RA, if conducted, shall also be opened after RA and the order will be placed on lower of the two bids (RA closing price & envelope sealed price) thus obtained. The bidder having submitted this offer specifically agrees to this condition and undertakes to execute the contract on thus awarded rates

19.If it is found that L1 bidder has quoted higher in online sealed bid in comparison to envelope sealed bid for any item(s), the bidder will be issued a warning letter to this effect. However, if the same bidder again defaults on this count in any subsequent tender in the unit, it will be considered as fraud and will invite action by BHEL as per extant guidelines for suspension of business dealings with suppliers/ contractors (as available on www.bhel.com).”

20.“Bidders to submit online sealed bid less than or equal to their envelope sealed bid already submitted to BHEL”

21.In case of tie for H1 bid (identical online sealed bids), 15 minutes additional time shall be provided and all the participating bidders shall be informed by mail/ message on bidding screen to enable bidders submit revised online sealed bids so as to break the tie.

CIVIL ENGINEERING DEPARTMENT,BHEL,TRICHY-14

(TO BE STAMPED IN ACCODANCE WITH STAMP ACT)

BANK GUARANTEE FOR SECURITY DEPOSIT

1. THIS DEED OF GUARANTEE made this..... day of(month).....(year)
By(Bank 's full address) in favour of M/s Bharat Heavy Electricals Limited, Unit : Thiruverumbur, Tiruchirapalli 620 014, having its Registered Head Office at BHEL House, Siri Fort , New Delhi 110049.

2. **WHEREAS M/s Bharat Heavy Electricals Limited (hereinafter called the "COMPANY")**
have placed work order(s) which are pending as on date and also proposes to place further work order(s)) (hereinafter called the "CONTRACT") upto..... (Date) for fabrications/ for machining/supply of pressure and non – pressure parts with M/s.....(CONTRACTOR'S Full address) (hereinafter called the "CONTRACTOR /SUPPLIER") and as per the terms of the contract, the company has issued /proposes to issue raw materials to the contractor to enable them to complete the work.

- 3.AND WHEREAS one of the conditions for placing such contract(s) is that the Contractor/ Supplier shall provide the Company a Bank Guarantee for Rs.in lieu of cash and towards the security deposit for the raw materials supplied and to be supplied, in pursuance of the contract(s) already placed but pending as on date and the contract(s) to be placed from time to time upto (Date) and also for the satisfactory performance and completion of work/supply as per the terms and conditions of the said contract(s).

- 4.AND WHEREAS the Contractor/ Supplier..... approached the (Bank) and at their request and in consideration of the arrangement arrived at between the said Contractor / Supplier and the said Bank,

5. We(indicate the name of the bank with full address), do hereby undertake to pay the amounts due and payable under this guarantee without any demur, merely on a demand from the Company stating that the amount claimed is due by way of loss or damage caused to or would be caused to or suffered by the Company by reason of breach by the said Contractor(s) of any of the terms and conditions contained in the said Agreement or by the reason of the contractor(s) 'failure to perform' the said agreement. Any such demand made on the Bank shall be conclusive as regards the amount due and payable by the Bank under this guarantee. However, our liability under this guarantee shall be restricted to an amount not exceeding Rs._____.

6. We..... (Bank) , further assure that the Contractor/ Supplier shall be responsible for the safe custody and protection of the raw materials that have been supplied/and to be supplied by BHEL under the contract(s) already placed but pending as on date and to be placed upto(date) against all risks till they are delivered back as finished products to BHEL as per the terms and conditions of the Contract or as they may direct and until such time, the Contractor/ Supplier shall hold the raw materials in trust for BHEL and shall not alienate the same in any manner whatsoever by way of

CONTRACTOR

34

ACCEPTING OFFICER

CIVIL ENGINEERING DEPARTMENT, BHEL, TRICHY-14

sale or mortgage or charge or hypothecation etc. in favour of any one else including the bank herein or any other banks /financial institutions etc.

The raw materials shall always remain the property of BHEL and the Bank shall indemnify BHEL against the loss, damage or deterioration whatsoever in respect of the said raw materials while in the possession of the Contractor/Supplier. The raw materials of BHEL shall always be open for inspection by any Officer authorised by BHEL. The liability under this Guarantee is a continuing one covering all contracts already placed but pending as on date and to be placed up to.....(date) and should any loss or damage occur on account of the breach of the terms and conditions of the said contract(s) by the Contractor/ Supplier or should any surplus raw materials become due to the Company under the Contract(s) and remains undelivered by the Company, the Bank shall indemnify the Company for the loss /damage for the value of raw materials for Rs...../- (RupeesOnly) and this is without prejudice to any other remedies which may be otherwise available to the Company by deduction from any sum due or any sum which at any time hereinafter become due from the Contractor/ Supplier under this or any other Contract(s).

- 7. We undertake to pay unconditionally to the Company any money so demanded notwithstanding any dispute(s) raised by the Contractor in any suit, or proceedings pending before any Court or Tribunal or Arbitration or before any other authority relating thereto our liability under this present being absolute and unequivocal. The payment under this guarantee would not wait till the disputes have been decided by any Court or Tribunal or in the arbitration proceedings or by any other authority. The payment so made by us under this Bond shall be a valid discharge of liability for payment thereunder and the Contractor(s) shall have no claim against us for making such payment.

- 8. We.....(indicate the name of Bank), further agree that the guarantee herein contained shall remain in full force and effect during the period that would be taken for the performance of the said Agreement and that it shall continue to be enforceable till all the dues of the Company under or by virtue of the said Agreement have been fully paid and its claims satisfied or discharged or till _____ Office / Department/ Division of the Company certifies that the terms and conditions of the said Agreement have been fully and properly carried out by the said Contractor(s) and accordingly discharges this guarantee.

- 9. (i) Unless a demand or claim under this guarantee is made on us in writing on or before the _____ we shall be discharged from all the liability under this guarantee thereafter. But where such claim or demand has been preferred by the Company with the Bank before the expiry of the said date, the claim shall be enforceable notwithstanding the fact that the said enforcement is effected after the said date.

CIVIL ENGINEERING DEPARTMENT, BHEL, TRICHY-14

- (ii) For the purpose of this clause, any letter making demand on the Bank by M/s. BHEL dispatched by Registered Post with Ack.Due or by Telegram or by any Electronic media addressed to the above mentioned address of the Bank shall be deemed to be the claim / demand in writing referred to above irrespective of the fact as to whether and when the said letter reaches the Bank, as also any letter containing the said demand or claim is lodged with the bank personally.

- 10. We(indicate the name of Bank), further agree with the company that the Company shall have the fullest liberty without our consent and without affecting in any manner our obligations hereunder to vary any of the terms and conditions of the said agreement or to extend time of performance by the said Contractor (s) from time to time or to postpone for any time or from time to time any of the powers exercisable by the Company against the said Contractor(s) and to forbear or enforce any of the terms and conditions relating to the said agreement and we shall not be relieved from our liability by any reason of any such variation or extension being granted to the said Contractor(s) or for any forbearance, act or omission on the part of the company or any indulgence by the company to the said Contractor(s) or by any such matter or thing whatsoever which under the law relating would but for this provision have effect of not so relieving us.

- 11. This guarantee will not be discharged due to the change in the constitution of the Bank or the Contractor(s).

- 12. It shall not be necessary for the company to proceed against the contractor before proceeding against the guarantor-bank and the guarantee herein contained shall be enforceable against them notwithstanding any security, which the company may have obtained or obtain from the Contractor shall, at the time when proceedings are taken against the guarantor hereunder be outstanding or unrealised.

- 13. Any claim or dispute arising under the terms of this document shall only be enforced or settled in the Courts at Tiruchirapalli.

- 14. The guarantor hereby declare that it has power to execute this guarantee and the executant has full powers to do so on its behalf under the proper authorities granted to him/them by the the guarantor.

- 15. We(indicate the name of Bank) lastly undertake not to revoke this guarantee during its currency except with the previous consent of the company in writing.

In witness whereof we....., (indicate the name of Bank) have

hereunto setout Bank Seal the _____ day

_____ month 200

CIVIL ENGINEERING DEPARTMENT, BHEL, TRICHY-14

Bank Phone No.

Bank e-mail ID

Bank FAX No

The Bank Guarantee bonds (BG) are to be submitted on non-judicial stamp paper of Rs. 100/- and should be only from any one of the below mentioned Banks in India.

LIST OF CONSORTIUM BANKS IN INDIA

(as on 15.12.2011)

List of Consortium Bank			
	Nationalised Bank		Nationalised Bank
1	Allahabad bank	19	Vijaya Bank
2	Andhra bank		Public Sector Banks
3	Bank of Baroda	20	IDBI
4	Canara Bank		Foreign bank
5	Corporation bank	21	CITI Bank N.A
6	Central bank	22	Deutsche Bank AG
7	Indian Bank	23	The Hongkong and Shanghai Banking Corporation Limited
8	Indian Oversea Bank	24	Standard Chartered Bank
9	Oriental bank of Commerce	25	The Royal Bank of Scotland N.V.
10	Punjab National Bank	26	J P Morgan
11	Punjab & Sindh Bank		Private bank
12	State Bank of India	27	Axis Bank
13	State Bank of Hyderabad	28	The Federal Bank Limited
14	Syndicate Bank	29	HDFC
15	State Bank of Travancore	30	Kotak Mahindra Bank
16	UCO Bank	31	ICICI
17	Union Bank of India	32	Indusind Bank
18	United Bank of India	33	Yes Bank

- (1) It should be typed in the **Rs. 100 value of stamp paper.**
- (2) It should be **signed by TWO bank officials** with Rubber stamp containing names & employee numbers of bank officials.
- (3) It should be submitted with bank covering letter with sign and seal of the bank official.

CONTRACTOR

37

ACCEPTING OFFICER

INSTRUCTIONS TO TENDERERS

1. The tender is open to all Contractors. The Contractors not borne on the approved list of contractors of this Organization must submit the following testimonials simultaneously with their tenders.
 - i. A Certificate to establish that the tenderer is an independent contractor working on his own
 - ii. At least two certificates from responsible Officers of Government of Firms of repute, regarding the tenderer's capacity to undertake to undertake and carryout the work tendered for or similar work satisfactorily

NOTE :

- a) Copies of testimonials unless attested a Gazetted Officer will not be accepted
- b) Non – Submission of the above testimonials simultaneously with the tenders may result in the tender being rejected
2. The tenders should be accompanied by a list of contracts already held by the contractor at the time of submitting the tender and giving the following particulars
 - a) Value of each contract
 - b) The balance value of work to be done on the same
3. The tenderer is advised to obtain the tender documents in person or by a messenger duly authorized to do so. The BHARAT HEAVY ELECTRICALS LIMITED will not under any circumstances accept responsibility for the non – receipt of delay in the receipt of the tender documents by the tender.
4. Percentage Rate for all items of the tender schedule should be quoted in FIGURES and in WORDS. In case of any difference in the rates quoted in figures and in words, the lower of the two percentage will be taken as the tendered percentage.

5. Taxes & Duties

The percentage rate offered is for finished item of works and shall provide for the complete cost towards fuel, tools, tackles, plant & machinery, temporary works, labour, materials, levies, taxes, transport, lay-out, repairs, rectifications, maintenance till handing over, supervision, establishment, services, revenue expenses, overheads, profits & all other incidentals etc., complete Rate quoted shall include all royalties, terminal taxes, Octroi duties, and any other taxes leviable under the State or Central Government rules. The Bharat Heavy Electricals Ltd., will not entertain any claim whatever in this respect.

The percentage rate quoted shall not include applicable GST.

- h. Response to Tenders will be entertained only if the contractor has a valid GST registration no which should be clearly mentioned in the offer.
- i. The Contractor shall mention their GST registration number in all their invoices and invoices shall be in the format as specified/prescribed under GST laws. Invoices shall necessarily contain Invoice number (in case of multiple numbering system is being followed for billing like SAP invoice no, commercial invoice no etc., then the Invoice No which is linked/uploaded in GSTN network shall be clearly indicated), item description as per PO, Quantity, Rate, Value, applicable taxes with nomenclature (like IGST, SGST, CGST & UTGST) separately, HSN / SAC Code, etc.

CIVIL ENGINEERING DEPARTMENT, BHEL, TRICHY-14

- j. All invoices shall bear the SAC code (Services Accounting Code) & HSN Code (if applicable) for each item separately (Harmonized System of Nomenclature).
- k. **Payment shall be effected only after submission of declaration to the effect that all invoice particulars are/were uploaded in the GSTN network/ portal & All tax liability as per GST rules and regulations have been and will be discharged, shall be mentioned in the invoice. If it is not mentioned in the invoice, a separate declaration shall be submitted as per the requirement of BHEL.**
- l. All documents like Work completion certificate and any other document mentioned in PO, shall be submitted.

For all works executed within the calendar month, input credit will be availed within that month in line with monthly returns filing cycle (if Input Tax Credit is applicable). In case of any discrepancy in the document or non-submission of documents mentioned in the PO, then BHEL will not be able to accept or account the works executed, in such case availing of tax credit will be deferred to next month or so.

- m. In case of discrepancy in the data uploaded by contractor in the GSTN portal or in case of any shortages or rejection in the works executed, then BHEL will not be able to avail the tax credit (if Input Tax Credit is applicable) and will notify the Contractor of the same. The Contractor has to rectify the data discrepancy in the GSTN portal or issue credit note (details to be uploaded in GSTN portal) for the shortages or rejections, within the calendar month notified by BHEL.
- n. For any such delay in availing of tax credit for reasons attributable to the Contractor (as mentioned above), interest (calculated @ SBI Base Rate + 6%) along with penalty if any will be deducted for the delayed period i.e. from the month of receipt till the month tax credit is availed, from the running bills.

All taxes and duty other than GST & GST Cess

The contract price shall be inclusive of all (save the specific exclusions as enumerated in this contract) taxes, fees, license charges, deposits, duties, tools, royalty, Octroi, commissions or other charges which may be levied on the input goods consumed and output goods delivered in the course of Works Contract. In case BHEL is forced to pay any of such taxes, BHEL shall have the right to recover the same from the contractors bills or otherwise as deemed fit.

Goods and service Tax (GST) & Cess

The contractor shall submit the proof of GST registration to BHEL at the offer stage. Contractor's price/rates shall be exclusive of GST & GST Cess (if applicable) herein after termed as GST. Contractor shall submit to BHEL the GST compliant tax invoice/debit note/revised tax invoice on the basis of which BHEL will claim the input tax credit in its return (if Input Tax Credit is applicable). GST charged in the tax invoice/debit note/revised tax invoice by the contractor shall be released separately to the contractor only after contractor files the outward supply details in GSTR-1 on GSTN portal and input tax credit of such invoice is matched with corresponding details of outward supply of the supply and has paid the GST at the time of filing the monthly return.

-
In case of deduction/excess in completion certificate/measurements, credit note /debit note shall be issued within the time limit prescribed in GST law and accordingly contractor shall adjust his tax liability.

CONTRACTOR

39

ACCEPTING OFFICER

CIVIL ENGINEERING DEPARTMENT, BHEL, TRICHY-14

If GST will be payable on reverse charge, then the same shall be payable directly to Govt by BHEL under reverse charge.

In case BHEL has to incur any liability (like interest, penalty etc.) due to denial or reversal of input tax credit for the reasons attributable to the contractor or any such delay in availing of tax credit for reasons attributable to the Contractor, the same shall be recovered from the contractor.

In case BHEL is deprived off the Input tax credit due to any reason attributable to contractor, the same shall not be paid to the contractor or will be recovered from the contractor.

TDS under GST (as & when applicable) shall be deducted at prevailing rates on applicable value from the running bills.

New Taxes/Levies - In case the Government imposes any new levy/tax on the output service/ goods/ after price bid opening, the same shall be reimbursed by BHEL at actual.

In case any new tax / levy / duty etc. becomes applicable after the date of Bidder's offer but before opening of the price Bid, the Bidder/Contractor must convey its impact on his price duly substantiated by documentary evidence in support of the same before opening of Price Bid. Claim for any such impact after opening the Price Bid will not be considered by BHEL for reimbursement of tax or reassessment of offer.

Tender Value is only approximate and liable for variation without entitling the tenderer to any compensation, till the total value of contract does not vary more than 20%. The contractor has to execute any item of work irrespective of the quantity available in the tender without any reservation till the contract value does not vary more than 20%.

6. Quoted rate shall be firm throughout the contract period of 12(Twelve) months and no cost escalation is allowed on any account including extended period if any.
7. The works contract to be entered in to with the contractor will be governed by the BHEL Revised General Conditions of contract in force.
8. Should a tender find discrepancies or omissions in the drawings or any of the tender documents or should be in doubt as to their meaning, he should at once address the authority inviting the tender for clarification. Every Endeavour is made to avoid any error which can materially affect the basis of the tender but the successful tenderer shall take upon himself to provide for the risk of any error which may be subsequently by discovered and shall make no subsequent claim on account thereof.
9. Tenders submitted by post should be sent "Registered Post with Acknowledgement due". These should be posted with due allowance for any delay in postal delivery. Tenders received after the due date and time of opening, tenders are liable to be rejected.
10. Where the tender called for covers only the building work and excludes internal services such as sanitary and water supply installations, electrification etc., the building contractor will have to leave pockets, holes, etc., as required for other

CONTRACTOR

40

ACCEPTING OFFICER

CIVIL ENGINEERING DEPARTMENT,BHEL,TRICHY-14

works and will have to phase his work to ensure smooth progress of the work of the other agencies also as directed by the Engineer – in – charge.

- 11. Where the tender schedule contains special items of work such special floor finishes, foam concrete for insulation, special water proofing treatment to roofs etc., it will be entirely at the discretion of the Project Authorities to allot these items of work to other contractors specialized in these works. In such cases, the main building Contractor will have to tender all necessary co-operation to the agencies involved so as to ensure the smooth progress of all work.
- 12. The contractor’s responsibility under this shall commence from the date of receipt of the contract order of acceptance of his tender. The Contractor will have to plan his work accordingly to complete the work within the scheduled period of completion.
- 13. Generally, the maintenance period for any work under BHEL Organization will be Six(6) months .
- 14. **Earnest Money Deposit:**
 - 15.1) EMD is to be paid by tenderers for securing fulfilment of any obligations in terms of the NIT. Earnest Money is to be paid by each tenderer to ensure that the tenderer does not refuse to execute the work after it is awarded to him.

15.2) Rates of EMD shall be as under:

For works/ services costing upto Rs 10 Crs	2% of the estimated cost
For works/ services with costing more than Rs10 Crs	Rs 20 lakhs plus 1% of the estimated cost over Rs 10 Crs

15.3) Mode of Deposit:

The EMD may be accepted only in the following forms:

- (i) Cash deposit as permissible under the extant Income Tax Act (before tender opening)
- (ii) Electronic Fund Transfer credited in BHEL account (before tender opening)
- (iii) Banker’s cheque/ Pay order/ Demand draft, in favour of BHEL ,Trichy (along with offer)

In case total EMD amount is more than Rs.20 Lakh, the amount in excess of Rs 20 lakh may be accepted in the form of Bank Guarantee from scheduled bank. The Bank Guarantee in such cases shall be valid for at least six months.

15.4) EMD by the Tenderer will be forfeited if,

- i) After opening the tender and within the offer validity period, the tenderer revokes his tender or makes any modification in his tender which is not acceptable to BHEL.
- ii) The Contractor fails to deposit the required Security deposit or commence the work within the period as per LOI/ Contract.

15.5 EMD by the tenderer shall be withheld in case any action on the tenderer is envisaged under the provisions of extant “Guidelines on Suspension of business dealings with suppliers/ contractors” and forfeited/ released based on the action as determined under these guidelines.

15.6 EMD shall not carry any interest.

15.7 EMD of successful tenderer will be retained as part of Security Deposit

CIVIL ENGINEERING DEPARTMENT, BHEL, TRICHY-14

16. Should a tenderer or a contractor on the list of approved Contractors have a relative, or in the case of a firm or Company of contractors any of its share holders or shareholder's relative, employed in a gazetted capacity in the Engineering Department of the Bharat Heavy Electricals Limited, the authority inviting tenders shall be informed of this fact at the time of submission of the tender, failing which tender, may be disqualified or if such fact subsequently comes to light, the contract may be rescinded in accordance with the relevant provisions in the General Conditions of Contract.
17. If tenderer expires after the submission of his tender or after the acceptance of his tender the BHEL may, at their discretion, cancel such tender. If a partner of a firm expires after submission of tender or after the acceptance of the Tender, BHEL may cancel such Tender at their discretion unless the firm retain its character.
18. The Bharat Heavy Electricals Limited will not be bound by any power of attorney granted by the tenderer or by changes in the composition of firm made subsequent to the execution of the contract. They may however recognize such power of attorney and changes after obtaining proper legal advice the cost of which will be chargeable to the contract concerned.
- 19. If the tenderer deliberately gives wrong information in his tender or creates conditions favorable for the acceptance of his tender, the Bharat heavy Electricals Limited, reserves the right to reject such tender at any stage.**
20. Words importing the singular number shall also be deemed to include the plural number and vice versa where the context so requires.
21. The expenses for competing and stamping the agreement shall be paid by the contractor.
22. The General and special conditions are complementary to each other and where they are conflict the Special Conditions shall prevail. In regard to matters not covered by the General and Special Conditions of Contract, those contained, those contained in the Tamil Nadu Building Practice Standard Specifications or other specifications approved by the Bharat Heavy Limited, Shall apply.
23. Tenderers shall not increase their quoted rates in case the Bharat Heavy Electricals Limited, negotiates for negotiation for reduction of rates. Such negotiation shall not amount to cancellation or withdrawal of the original offer and the rates originally quoted shall be binding on the tenderers for a period of three months from the date of opening of tenders.
24. Canvassing in any form in connection with tenders is strictly prohibited and the tenders submitted by the contractors who resort to canvassing will be liable to rejection
25. If, in case of opening of price bids, when there is a Tie in the percentage rates quoted by the tenderers, the ranking will be decided based on Lot System, in the presence of the bidders who witness the price bid opening.

CIVIL ENGINEERING DEPARTMENT, BHEL, TRICHY-14

TENDER NOTICE

TOTAL ESTIMATED COST : Rs.212 LAKHS (For All the Four Packages)

1. SEALED TENDERS for the above noted work are hereby invited from contractor experienced in works of similar kind and magnitude. Tenders will be received by **SM/CIVIL/PLANNING, Design & QC** Bharat Heavy Electricals Limited, Tiruchirappalli – 620 014. Up to **10.00 Hrs. on 15.05.2018** and will be opened on the same day at **10.00 Hrs.** at the **Office of the SM/CIVIL/PLANNING, Design & QC**.
2. TENDER FORMS and other particulars regarding the proposed work can be obtained on any working day from 8.00 A.M. to 4.30 P.M. up to **14.05.2018** on payment of the prescribed sum of Rs. **750** per set (including Sales Tax) in the form of Demand Draft Amount nor refundable.
3. TENDERS must be submitted in sealed covers and should be addressed to the with full name and address of the tenderer and the name of work being noted on the cover
4. All entries in the tender documents should be in the one ink. Erasers and over writings are not permitted. All cancellations and insertions should be duly signed by the tenderer concerned.
5. TENDERERS should fill in all the required particulars in the blank spaces provided for this purpose in the tender documents and also sign each and every page of Tender Documents including the drawings attach there to before submitting their tender.
6. Percentage rate should be quoted in figures as well as in words for all the items shown in the attached schedule. These rates shall be for the finished work in site.
7. QUANTITIES shown in the attached schedule are only approximate and are liable to variation without entitling the Contractors to any compensation, provided the total value of the Contract does not vary by more than 30% (thirty percent)
8. In quoting their rates, the tenderers are advised to take account all factors including any fluctuations in the market rates etc. No claim will be entertained on this account after acceptance of the tender or during the currency of the contract.
9. Before tendering, the tenderers are advised to inspect the site of work and its environments and be well acquainted with the actual working and other Prevalent conditions position of materials and labour, General and Special Conditions of Contract. Instructions to tenders, drawings and Specifications and all other documents which form part of the Agreements to be entered into.
10. The rates quoted in the tender shall remain valid for a period THREE MONTHS from the date of opening of tenders.
11. In the event of tender being submitted by firm the tender must be signed separately and legibly by each partner or member of the firm or in their absence, by the person holding the power of attorney on behalf of the firm concerned in the latter case a copy of the power of attorney duly attested by a Gazetted Officer must accompany the tender.
12. Every tender must be accompanied with EMD for the amount as specified in any of the form mentioned in Para 12 of the "Instruction to Tenderers". This Earnest Money will be refunded to the unsuccessful tenderers within fifteen days of finalization of the award of work. In case of the successful tenderer, the Earnest Money will be retained as part of the Security Deposit for satisfactory completion of the work in accordance with Clause 16 of the General Conditions of Contract

NOTE : Cheques, Currency Notes and Money Orders will not be accepted in lieu of the deposit receipt referred to above

CONTRACTOR

43

ACCEPTING OFFICER

13. Security Deposit

13.1 The Security Deposit shall be collected from the successful tenderer. The total amount of security deposit will be 5% of the contract value. EMD of the successful tenderer shall be converted and adjusted towards the required amount of Security Deposit.

At least 50% of the required Security Deposit, including the EMD has to be furnished by the contractor before commencement of the work.

Failing which the recovery of interest will be made at prime lending rate of SBI plus 2% for the period of default.

13.2 Security Deposit may be furnished in any one of the following forms:

- i. Cash (as permissible under the extant Income Tax Act)**
- ii. Local cheques of Scheduled Banks (subject to realization)/ Pay Order/ Demand Draft/ Electronic Fund Transfer in favour of BHEL**
- iii. Bank Guarantee from Scheduled Banks/ Public Financial Institutions as defined in the Companies Act. The Bank Guarantee format should have the approval of BHEL**
- iv. Fixed Deposit Receipt issued by Scheduled Banks/ Public Financial Institutions as defined in the Companies Act (FDR should be in the name of the Contractor, a/c BHEL)**
- v. Securities available from Indian Post offices such as National Savings Certificates, Kisan Vikas Patras etc. (held in the name of Contractor furnishing the security and duly endorsed/ hypothecated/ pledged, as applicable, in favour of BHEL)**

(Note: BHEL will not be liable or responsible in any manner for the collection of interest or renewal of the documents or in any other matter connected therewith)

13.3 Security Deposit can also be recovered at the rate of 10% of the gross amount progressively from each of the running bills till the total amount of the required Security Deposit is collected. However in such cases at least 50% of the Security deposit should be collected before start of the work and the balance 50% may be recovered from the running bills.

(Note: In case of (a) small value contracts not exceeding Rs 20 lakhs or (b) SAS jobs, work can be started before the required Security Deposit is collected. However, payment can be released only after collection/ recovery of initial 50% Security Deposit).

The Security Deposit shall not carry any interest

14. Unless the contractor whose tender is accepted signs the Contract Agreements and makes the necessary security deposit specified in Para 13 above within Seven days of the date of the order directing him to do so the amount of Earnest Money Deposit already deposited by him will be forfeited and acceptance of his tender withdrawn.

CIVIL ENGINEERING DEPARTMENT,BHEL,TRICHY-14

15. If after opening of tenderer revokes his tender or increases his earlier quoted rates or after acceptance of his tender does not commence the work in accordance with the instruction of the Engineer-in-charge, the Earnest Money deposited by him will be forfeited and acceptance of his tender withdrawn. If only a part of the work included in the tender had been awarded to the tenderer, the amount of Earnest Money to be forfeited will be based on the value of the contract so awarded.
16. The Bharat Heavy Electricals Limited reserve the right to reject any or all the received or accept any tender or part there of without assigning any reason thereof. In the case acceptance of part of tender, time for completion may also be reduced to the extent considered appropriate by the Accepting Authority.
17. Conditional and Unwitnessed tenders, tender containing absurd rates and amounts tenders which are incomplete or otherwise considered defective and tenders not in accordance with the tender conditions laid down by the Accepting Officer are liable to be rejected.
18. Tenders not submitted on the prescribed form are liable to be rejected
19. The work must be completed within a scheduled completion period .
20. The Chairman / General Manger / Deputy General Manager / Deputy Manager / Senior Engineer shall be Accepting Officer, herein after referred to as such for the purpose of this contract.
21. This tender notice shall be deemed to form an integral part of the contract to be entered into for this work.
22. The tenderers are advised to go through the condition stipulated in Tender document & code of conduct for 'Health & Safety of Contract Labour

CLIENT'S CERTIFICATE REGARDING PERFORMANCE OF CONTRACTORS

Name & Address of the Client

.....
.....

Details of works executed by Shri . M/s

.....

1. Name of work with brief particulars :
2. Agreement No. and date :
3. Date of commencement :
4. Stipulated date of completion :
5. Actual date of completion :
6. Details of compensation levied for delay, if any:
7. Tendered amount :
8. Gross amount of the work completed :
9. Name and address of the authority under whom work executed :
10. Whether the contractor employed qualified Engineer/Overseer during execution of work? :
11. (i) Quality of work (indicate grading) Outstanding/V.Good/Good/Poor :
(ii) Amount of work paid on reduced rate basis, if any :
12. (i) Did the contractor go for arbitration ? :
(ii) If yes, amount of claim :
(iii) Amount received :
13. Comments on the capabilities of the contractor
(a) Technical Proficiency Outstanding/V.Good/Good/Poor :
(b) Financial Soundness Outstanding/V.Good/Good/Poor :
(c) Mobilisation of adequate T & P Outstanding/V.Good/Good/Poor :
(d) Mobilisation of manpower Outstanding/V.Good/Good/Poor :
(e) General behaviour Outstanding/V.Good/Good/Poor :

NOTE: All columns should be filled in properly.

Signature of the Certifying Officer
with Official seal.

CONTRACTOR

46

ACCEPTING OFFICER

SPECIAL CONDITIONS OF CONTRACT

1. No night work will be permitted without the written permission of the Engineer – in – charge.
2. Bulkage test on the sand to be used on the work should be conducted periodically to arrive at the correct quantity of sand to be mixed for the different proportions as and when required.
3. Items of work other than those mentioned in the Bill of Quantities (Tender Schedule) attached hereto will be carried out at the rates to be fixed by this organization as per relevant clauses of the General Conditions of Contract.
4. On the written request from the contractor **Water required for the work may be provided by this organization at only one point at the site of the work at free of cost.** In case of failure of water supply, the Contractor will have to make his own arrangements for water without any extra claims until supply is restored. BHEL does not accept any liability whatsoever for non-supply or delay in the supply of water under any circumstances. The contractor shall ensure that there is no wastage of water otherwise supply of water, is liable to be stopped at contractor’s risk and cost.
5. On the written request from the contractor **Electrical energy required for the work may be given by this organization at any one point at the site of work at free of cost.** BHEL does not accept any liability whatsoever for non-supply, delay in supply or failure of supply of electrical energy. Contractor shall ensure that there is no wastage of electrical energy otherwise supply is liable to be stopped at contractor’s risk and cost. The contractor shall make leak proof / fire proof shed and provide control panel board of required capacity and lay the required cables at their own cost for further distribution.
6. On the written request from the contractor **Compressed air for the work will be provided by this organization at only one point near the site of work at free of cost.** The contractor should be in a position to make his own arrangement for compressed air without any extra claim for the uninterrupted operation of jackhammer with silencer wherever BHEL is not in a position to supply compressed air.
7. Permission for erection of temporary work sheds etc., at site will have to be obtained from BHEL in writing in advance.
8. The works contract to be entered into with the successful tenderer will be governed by the BHEL revised General Conditions of Contract in force.
9. The successful tenderer / Contractor shall observe all safety regulations and take necessary safety precaution as called for under the “BHEL General Conditions of Contract and Safety Precautions” enclosed herewith.
10. In all matters of dispute, the decision of the General Manager, Bharat Heavy Electricals Ltd., Tiruchirappalli – 620 014. shall be final and binding on the tenderer / contractor.

CIVIL ENGINEERING DEPARTMENT, BHEL, TRICHY-14

11. Some changes are likely in the quantities furnished as well as in the layout, design and specifications of the work. The rate quoted shall be deemed to be inclusive of all such contingencies.
12. All the materials to be used in the work and nature of work shall conform to respective TNBP, IS and National Buildings Organisation Standard Specifications and shall be got approved by the Engineer – in – charge before actual incorporation in the work
13. Unless otherwise indicated in the Bill of Quantities cement, reinforcement steel (MS rods, CTD bars etc.), structural steel sections and other items (as mentioned in Schedule B) will be issued at BHEL Stores at free of cost. The Contractor's quoted rates shall therefore be inclusive of the cost of conveyance of these items from BHEL Stores to site of work including, loading, unloading and other incidental costs etc. The quantities of each items to the extent required for actual incorporation of the work will be treated as ISSUED FREE OF COST.
14. **CEMENT:**
Excess consumption of cement over and above the theoretical requirement as per BHEL Data upto a limit of 5% will be charged at the rate of Rs.6,668/per M.T. + applicable taxes at the time of recovery. Consumption beyond 5% will be charged at the punitive recovery rate of Rs.13, 336/per M.T.+ applicable taxes at the time of recovery.

The above rates are only indicative and BHEL issue rate on date of actual issue will be applied.

Gunny bags or Polythene Bags or Paper Bags in which cement is issued from BHEL Stores, need not be returned by Contractor to BHEL. The cost for each empty cement bag will be recovered from the Contractor's bills at the following rates.

i.	Empty cement gunny bag	Rs.1.25 + ST and SC / each
ii	Empty Polythene bag	Rs. 0.50 + ST and SC / each
iii	Empty paper bag	Rs. 0.25+ST and SC / each.

15. REINFORCEMENT STEEL:

All surplus reinforcement rod with the contractor shall be returned to BHEL Stores at his own cost in the form of full lengths, useful cut bits and scrap. The invisible (non-returnable) wastage should not exceed a maximum of 0.5% of the actual quantity consumed in the work.

The contractor shall return all the scrap to the disposal stores at his own cost. Bent rods will also be taken as scrap only, irrespective of their length. The maximum permissible limit of scrap without recovery is 5% of actual consumption. The recovery details for the materials are as follows:

- a) **Single recovery rate for the non-returned scrap up to 5% of actual consumption** : **Rs.49,547/- per M.T + applicable taxes at the time of recovery**
- b) **The punitive recovery rate for steel qty. not accounted and extra scrap generated beyond 5% of actual consumption** : **Rs.99,095/- per M.T. + applicable taxes at the time of recovery**

The above rates are only indicative and BHEL issue rate on date of actual issue will be applied.

CONTRACTOR

48

ACCEPTING OFFICER

16. STRUCTURAL STEEL SECTIONS:

All surplus raw steel remaining with the contractor shall be returned to BHEL stores at his own cost after completion of fabrication, in the form of full lengths, useful cut bits and scrap. The following yardstick will be adopted for the purpose of classification of scrap.

(a) Mild steel and alloy steel plates and sheets	1000X500mm and above	Useful cut bit
(b) Mild steel and alloy steel plates and sheets	Less than 1000 X 500 mm	Scrap
(c) Structural	One metre and above in length	Useful cut bits
(d) Structural	Less than one metre in length	Scrap

The invisible (Non-returnable) wastage should not exceed a maximum of 2% by weight of fabricated steel work and returnable wastage generated by way of scrap or useful cutbits shall be returned at "Actuals". Maximum permissible limit for scrap without recovery shall be 5% of actual fabricated quantity. However every care should be taken to see that raw steel is utilized most economically by preparing necessary cutting lists to restrict the scrap within the permissible limit.

Should the quantum of invisible wastage exceed the 2% permissible limit, RECOVERY AT TWO TIMES OF THE VALUE OF the extra tonnage involved (which will be evaluated on an average cost per tonne basis considering the total raw steel materials issued) will be effected from the contractor for the excess quantity involved (**2 times x Rs. 48,495 = Rs.96, 990 / MT + applicable taxes at the time of recovery**).

The above rates are only indicative and BHEL issue rate on date of actual issue will be applied.

The Contractor shall submit a material tallying statement on completion of the work indicating the details of quantities of each material (section by section) received quantities used for fabrication as per DOD lists. Quantity returned in full length, useful cut bits and scrap and the quantity reckoned as invisible wastage.

i)

For Structural Steel:

- a) **Single recovery rate for the non-returned scrap up to 5% of actual consumption** : **Rs.48,495/- per M.T + applicable taxes at the time of recovery**
- b) **The punitive recovery rate for steel qty. not accounted and extra scrap generated beyond 5% of actual consumption** : **Rs.96, 990/- per M.T. + applicable taxes at the time of recovery**

ii)

For Rails:

- a) **Single recovery rate for the non-returned scrap up to 5% of actual consumption** : **Rs.65,739/- per M.T + applicable taxes at the time of recovery**
- b) **The punitive recovery rate for steel qty. not accounted and extra scrap generated beyond 5% of actual consumption** : **Rs.1, 31,478/- per M.T. + applicable taxes at the time of recovery**

CIVIL ENGINEERING DEPARTMENT, BHEL, TRICHY-14

iii) For ERW Tubes:

- a) Single recovery rate for the non-returned scrap up to 5% of actual consumption : Rs.42,534/- per M.T + applicable taxes at the time of recovery
- b) The punitive recovery rate for steel qty. not accounted and extra scrap generated beyond 5% of actual consumption : Rs.85, 068/- per M.T. + applicable taxes at the time of recovery

iv) For Seamless Steel Tubes:

- a) Single recovery rate for the non-returned scrap up to 5% of actual consumption : Rs.1,23,260/- per M.T + applicable taxes at the time of recovery
- b) The punitive recovery rate for steel qty. not accounted and extra scrap generated beyond 5% of actual consumption : Rs.2, 46,520/- per M.T. + applicable taxes at the time of recovery

The above rates are only indicative and BHEL issue rate on date of actual issue will be applied.

17. The Contractor should maintain proper accounts of cement, MS rods / CTD bars, structural steel sections and other materials if any supplied by this organization and these should be available at the site of the work for verification and check by the official of this organization at any time.
18. All materials brought by the Contractor for incorporation in the work shall be got inspected and approved by the Engineer-in-charge before they are incorporated in the work
19. The Manager / Civil or his duly authorized representative shall have all reasonable times access to Contractor's premises of work and shall have the power at all the reasonable times to inspect and test any portion of the work or examine the materials and workmanship of the structures during their manufacture and test. The contractor shall give due notice in writing to the Inspecting Engineer of BHEL when the materials supplied to be incorporated in the work are ready for inspection and test. No material shall be incorporated in the work until the inspecting Engineer certified in writing that such materials have been inspected and approved by him.
20. The Contractor shall closely scrutinize all the drawings issued in connection with the work by this organization and bring to the notice of the Engineer-in-charge if any discrepancies, omissions in the drawings before undertaking the actual work pertaining thereto.
21. The contractor should submit in advance every fortnight a detailed programme of work to be undertaken from time to time strictly in conformity with the "Time and Progress Chart" covering the entire constructed work and reschedule them wherever necessary during the progress of the work so as to achieve the target set. Periodical progress reports of every fortnight should also be furnished by the Contractor regarding the collection of materials issued and to be issued from BHEL Stores and other relevant information as asked for by the Engineer-in-charge and other BHEL Officers-in-charge of the work.
22. The contractor should extend full co-operation to the other contractors who may be doing other works in the same areas to enable them to execute their portions of work without any delay or difficulty.

GENERAL TECHNICAL CONDITIONS OF CONTRACT

GENERAL AND SPECIAL SPECIFICATIONS

1. Site Clearance

All the area upon which the construction is to be carried out and areas which are required by the Contractor for his construction facilities are to be cleared off all rubbish and objectionable matter at Contractor's own cost. Trees, if any, shall not be uprooted or cut without the prior approval of the Engineer-in-charge. All spoils, unserviceable materials and rubbish shall be burnt or removed from site. Usable materials, saleable timber, fire-wood etc., shall be stocked properly at work site in the manner as directed by the Engineer-in-charge. The cost of clearing the areas shall be deemed to have been included by the tenderer in his general rate.

2. Earthwork for Foundations

Earthwork excavation for foundations and filling in foundations shall conform to TNBP 23 and 24. The area to be excavated or filled in with excavated materials shall be clearly demarcated in the field by the Contractor. Excavation shall be done to lines and levels defined. Excavation shall be carried out to such widths, lengths, depths, profiles and grades as shown in the drawing or as may be specified by the Engineer – in – charge. Rough Excavation may be carried out up to a depth 15 cm less than the final level but the balance shall be excavated to precise level with special care. All soft pockets of soil met with even below the final level shall be removed and the excavation filled up as directed by Engineer-in-charge. The methods of excavation shall in every case be subject to the approval of the Engineer-in-charge and the contractor shall ensure the safety and stability of the excavations, being executed by him as well adjacent buildings, structures, services and other works in the vicinity of the site of work. Wherever necessary Engineer-in-charge may direct that the sides of the excavation should be timbered and shored at the contractor's own cost, adopting a proper method approved by the Engineer-in-charge. Notwithstanding the above, should any slip occur, the contractor shall remove all the slipped materials from the excavated pit, at his own cost. He shall also make good at his own all damages caused to the work as well as adjacent buildings, structures etc., as a result of the slip, referred to.

All excavation work shall be subject to inspection and approved by the Engineer-in-charge before any further works in the excavated areas allowed to commence. Should any excavation be carried out beyond the specified depth, the contractor should fill it up at his own cost with the same type and class of material as it is proposed to be laid over the excavated portion. No payment will however be made to the contractor on his account. The contractor shall ensure that the excavations and the structures under construction are kept free from water logging at all stages of construction. He shall take all necessary precautions and `streams, aquifers, springs, surface flows etc., are excluded effectively so as to ensure that the works are carried out in a reasonable dry conditions in accordance with the construction schedule. Back filling around the foundations, trenches, plinth and under the floor shall be done in accordance with TNBP 24 and 25. The finished level of the plinth filling shall be trimmed to the slope required to be given to the finished floor. Back filling, watering and consolidation of excavated earth in layers etc., complete as per specifications shall be done unless otherwise stipulated in the tender schedule.

Removal of Hard rock by Blasting

This shall include all rock occurring in large masses which cannot be removed except by blasting. Blasting shall be done in conformity with TNBP 19 & 23 and as instructed by the Engineer-in-charge. When rock blasting has to be done adjacent to structures, the following precautions shall be observed.

- (1) All blasting should be completely muffled to prevent damage by flying pieces.
- (2) Blasting within 3 meters of the structures shall be avoided
- (3) No blasting should be done within 1.5 meters of concrete / masonry structures.
- (4) An isolated boulder extending under the existing structure but projecting within the area of blasting should be blasted.
- (5) The contractor shall be responsible for all damages caused by blasting and shall replace or repair the damaged structures at his own cost.

3. Plain and Reinforced Cement Concrete Works:

All design and construction shall be performed in accordance with the Indian standard code of Practice for plain and reinforced concrete – IS 456 and TNBP 30. Any Special requirements noted on the drawings or bill of quantities shall govern over the provisions of this specifications. Controlled concrete shall be used wherever specified in the schedule of items complying with all requirements of IS: 456 and as per special specifications appended herewith. The coarse aggregate to be used shall be of hard broken granite stone jelly of various sizes as specified under respective items in the Bill of Quantities, conforming to IS 383 latest edition. The Engineer-in-charge may require the contractor to carryout moisture content tests in both fine and coarse aggregates. For determination of moisture content IS – 2386 shall be referred to. The amount of water to be added shall be then adjusted to compensate for any observed variation in the moisture contents. Proper control of mixing water is deemed of paramount importance. Mixtures with automatic water measuring drums shall be used or else. Water should be measured by volume in calibrated buckets. All measuring equipments shall be maintained in a clean serviceable condition and the accuracy periodically checked and got certified by the Engineer-in-charge. The contractor shall carryout slump tests apart from taking test cubes at regular intervals. All such methods of sampling and analysis of concrete shall be in accordance with IS – 1199.

Mixing of concrete shall be strictly carried out in an approved type mechanical mixer. The mixing equipment shall be capable of combining the aggregates, cement and water within the specified time (not less than 2 Minutes) into a thoroughly mixed and uniform mass and of discharging the mixture without segregation. Mixing shall be continued until there is a uniform colour and consistency, Concrete shall be handled from the place of mixing to the place of final deposit as rapidly as practicable by methods which will prevent segregation or loss of any of the ingredients. Before depositing the concrete, all debris and dirt shall be removed from the space to be occupied by concrete. Concreting shall not be done unless the formwork conform to the shapes, lines and dimension as shown in the drawings.

Unless otherwise approved, concrete shall be placed on single operation to the full thickness of slabs and beams and similar members and not exceeding 1 metre deep in walls, columns and similar members. Concrete shall be placed continuously until

CIVIL ENGINEERING DEPARTMENT, BHEL, TRICHY-14

completion of the part of the work between construction joints or as directed by the Engineer-in-charge. The concrete after being laid shall be compacted by means of vibrators of approved type under proper supervision as directed by the Engineer-in-charge. Care should be taken to avoid segregation and formation of air bubbles. The whole process starting from the mixing of concrete to the placing and compaction shall not take more than 20 minute and the process shall be completed before the initial setting takes place. Curing shall be accomplished in accordance with IS-456 by keeping the concrete covered with a layer of sacking, canvas or similar absorbent materials and kept constantly wet for the period as directed by the Engineer-in-charge.

Reinforcement

All reinforcement shall be clean and free from pitting, loose mill-scales, dust, loose rust and coats of paint, oil or other coatings which may destroy or reduce bond. General construction details and workmanship relative to reinforcement including bar bends, lap splices and installation shall be in accordance with the IS-2502 as well as IS-456. All bars be bent as per the bar bending schedules indicated in the drawings or supplied separately relevant to particular drawing. The contractor shall in all cases verify himself the correctness of schedules, giving the number, length and the bending details of the bars. The numbers, sizes, shape and position of all the reinforcement shall, unless otherwise, directed or authorized by the Engineer-in-charge be strictly in accordance with the drawing. The reinforcement shall be adequately held in position by 18 / 20 SWG soft black annealed binding wire. The contractor must obtain the approval of Engineer-in-charge for the reinforcement placed, before any concrete is placed in the form. All reinforcing bars shall be so tied as to form a rigid cage to prevent displacement before or during concreting. Rate quoted for reinforcement should include cost of transporting M.S. Rods / CTD bars from BHEL Store to site of work, cleaning, cutting, bending, placing, binding with contractor's own binding wire and providing necessary cover blocks of concrete but excluding cost of steel which shall be supplied free of cost at BHEL Stores.

Form Work

Formwork shall conform to the shape, lines and dimensions of concrete and RCC structures as shown in the drawings and shall be well within the permissible tolerance. Formwork for concrete shall be of plywood, steel, good seasoned timber or other approved materials, properly designed easy for removal and cleaning. They shall be of sufficient strength and rigidity to maintain their position and shape under loads incidental to placing concrete. The number of props, their sizes and dispositions shall be such as to able safely carry the full dead load area constructional loads. The arrangement and alignment of formwork shall be got approved by the Engineer-in-charge prior to concreting. However this shall not relieve the contractor from his responsibility for proper work and safety. Formwork shall be sufficiently tight to prevent loss of cement slurry from the concrete. All joints and holes in the formwork shall be caulked with putty jute cloth or other approved materials to the satisfaction of the Engineer-in-charge. The stripping time for the shuttering and the formwork shall in general conform to the provisions in the relevant clauses of IS 456. Unless otherwise specified rates for reinforced cement concrete shall include cost of centering, shuttering charges also.

Expansion and Other Joints

Expansion Joints in concrete structures shall be provided at specified places as indicated in the drawings. The material shall be as specified by the Engineer-inc-charge, expansion joints, with or without metal strip shall be as shown on drawings the filler shall be "EXPANDEX JOINT FILLER" premoulded non – extrudent type fibrous joint filler

impregnated with bitumen conforming to IS : 1838. The filler shall be durable, waterproof, compressible and shall have a high degree recovery after compression is released, ensuring thereby that no free space develops in the expansion joints. The top 25 mm, or as specified in the drawings, shall be sealed with "SHALITEX SEALING COMPOUND" or equivalent after application of approved primer.

4. Stone Masonry

General: Stone masonry shall conform to TNBP 35. Stone shall be obtained from the approved quarry and shall be free from decay and weathering. All stones shall be thoroughly wetted before use. The mortar used for jointing shall be as specified under the respective items of the ' Bill of Quantities'. The walls shall be carried up truly plumb. Every stone shall be carefully fitted to the adjacent stones so as to form neat and closed joints.

To give sufficient lateral bond, vertical joints shall be avoided. Prescribed number of headers as required shall be provided to give sufficient transverse bond. At junctions of wall the stones each alternate course shall be so carried into each of the respective walls as to unite the work thoroughly. Where breaks are unavoidable in carrying up the work continuously in horizontal course sufficiently long steps shall be left to joint the old and new work building of two thin faces and filling up the middle with small stuff or dry packing shall be strictly avoided. When plastering or raised pointing is not required to be done joints shall be struck flush and finished simultaneously.

Coursed Rubble Masonry

Coursed rubble masonry shall conform to TNBP 35-H, I and J. Faces shall be accurately squared and all face joints shall be dressed at right angles. This bushing on the facing stones shall not project more than 38mm.

Face stones shall be laid alternate headers and stretchers. Depth of each course shall not be less than 150 mm. No course shall be greater than any course below. The height shall not exceed the breadth of stones of face. No stone shall tail into the wall less than its height. No pinning shall be allowed on the face. The stones shall be solidly bedded set full in mortar with joints not exceeding 12 mm in thickness.

Random rubble masonry

Random rubble masonry work shall conform to TNBP 35-L and J. Stones shall be hammer dressed at faces and joints to enable them to come into close proximity with each other. The face stone shall be laid headers and stretchers alternately, so as to break joint by at least 75mm. Thickness of joint shall not exceed 12mm. No pinning shall be used on the face and face stone shall extend well back into the headers. Stones less than 130 mm. in height shall not be used on the face.

Bond stones running through the wall shall be provided at 1.8M intervals in walls up to 0.60 M. thickness and if the wall is more than 0.60 M. thick a line of headers shall be laid from face to back each header overlapping the other by at least 150 mm.

5. Brick Masonry:

First class Bricks: Brick shall be sound, hard, tough, rectangular in shape and size, well burnt of uniform deep red or copper colour and conform to IS – 1077. Brick shall be free from cracks, chips, flaws, stone or humps of any kind. Bricks shall be homogeneous in texture and evict a clear ringing sound on being struck and shall have a minimum

CIVIL ENGINEERING DEPARTMENT, BHEL, TRICHY-14

compressive strength of 50KG / sq.cm. and shall not absorb water more than 20% of its weight, when soaked cold water for 24 Hrs. All bricks shall be table moulded. Second Class Bricks: These shall be ground moulded but should otherwise conform to the specifications of first class bricks except for some surface cracks are allowable. These shall have minimum compressive strength of 50 Kg./sq.cm. Samples of each type of brick, shall be got approved by the Engineer-in-charge before being used. All subsequent deliveries shall be up to the standards of the approved samples. Brickwork shall conform to TNBP31 and IS –2212. Brick works shall be classified as first or second class according to the classification of bricks used and the method of laying. The thickness of joints shall not exceed 6 mm. In first class brickwork and 10 mm in second class brick work. Bricks shall be well soaked before use on works for at least 6 hrs. The soaked bricks shall be kept on wooden planks or platform. Brick required for masonry with clay or lime mortars shall not be soaked. Brickwork shall be laid with specified mortar to be prepared in accordance with IS –2250. Brick works shall be laid in English Bond unless otherwise specified. Half or cut bricks shall not be used except when needed to complete the bond. Each course shall be taken up truly plumb, if battered, the batter is to be truly maintained. The level of brickwork shall be checked up at every one metre interval. Bricks shall be laid with frogs upward, while laying bricks shall be thoroughly bedded and flushed in mortar and taped into position with a wooden mallet and the superfluous mortar removed. Walls of all structures shall be carried up regularly in all cases, leaving no part, one metre lower than the other. Where the masonry of one part has to be delayed, the work shall be raked back according to bond (and not toothed) an angle not exceeding 45 Deg. But the raking back should not start within 60cm. of a corner vertical joints in alternate courses shall come directly over one another. The brickwork shall not be raised more than 14 courses per day. All iron fixtures, pipes, conduits, drains, sleeves, bolts, holdfasts of doors and windows etc. which are required to be built in walls shall be embedded in cement mortar or cement concrete as specified, in their correct position as the work proceeds.

Joints

Joints shall be restricted to 6 mm in first class brickwork and 10mm in second class brick work. All bed joints shall be normal to the pressure upon them, radial in arches and at right angles to the face in battered retaining walls. Care shall be taken that all joints are fully mortared (proportion as specified in the schedule items) well flushed up and in case where no pointing to be done, neatly struck at the work proceeds. The joints in faces which are to be plastered or pointed shall be squarely raked out to a depth of 12 mm while the mortar is still green. The raked joints shall be well brushed to remove loose particles. After the work the faces of work shall be cleared well by brush so as to remove any splashed mortar during the course of raising the brickwork.

Curing

Green work shall be protected from rain by suitable covering. Masonry work shall be kept thoroughly well watered on all faces for atleast 10 days after completion. In case of fat lime mortar curing shall commence two days after laying of masonry and shall continue for seven days.

6. Scaffolding

Scaffolding will generally be single but may be double if warranted for the particular work as approved by the Engineer-in-charge. The contractor shall take all measure to ensure safety of work and the working people. Payment for brickwork shall be made on cubic metre basis on the volume of actual work done. Half brick wall and brick on edge wall shall be paid on square metre basis. The rate of brick work shall include scaffolding and all items mentioned above and no extra payment will be made for cutting bricks if required either for openings or for rounding or insertions or for recesses at the time of brick wall construction.

7. Damp Proof Course

Damp proof course shall either be with cement concrete or with cement mortar of specified thickness as mentioned in the relevant item of schedule. Damp proof course shall not be carried across doorways. It shall be laid for all walls except verandah retaining wall or for particular wall only directed by the Engineer-in-charge. It shall be laid flush with floor level or as instructed by the Engineer-in-charge. Damp proof course with cement concrete shall be of 25 or 38 mm thick in cement concrete M15/M20 as specified using 12mm. and down size aggregate well rammed and smoothed with trowel. It will be kept wet for 40 hours and after it has dried, two coats of hot bitumen shall be applied over it and allowed it to dry after which sand shall be sprinkled over it. Damp proof course with cement mortar shall be 12 or 20 mm thick in cement mortar 1:3 well mixed with crude oil at 5% by weight of cement used.

8. Cement Plastering:

Cement plastering shall be in accordance with IS – 1661 and TNBP –56 & 57, Cement mortar shall conform to IS – 269. The mortar of specified mix and thickness shall be used.

The surface to be plastered shall be thoroughly cleaned so that it is free from dust, oil, salts etc., the joints of masonry shall be raked out to a depth of at least 12 mm. On cement concrete surfaces the surface shall be cleaned with wire brush and scarified by lines with trowel or hacking done. The surfaces in both cases shall be washed properly and kept wet for 4 hours before plastering is commenced. Plastering shall be started from top and gradually worked down towards the floor. It shall not at any place be thinner than specified. To ensure even thickness plaster of about 15 cm X 15 cm shall be first applied horizontally and vertically at not more than 2 metres intervals over the entire surface to serve as gauges. The surface of these gauges shall be truly in the plane of finished surface. The mortar shall then be laid in the wall or other surfaces between the gauges and finished even. All corners shall be rounded to a radius of 24 mm unless otherwise directed. The contractor shall not be paid for any extra thickness of plaster done than as specified. Plaster, when more than 15 mm thick shall be applied in two coats, a base coat followed by the finishing coat. Thickness of the base coat shall be just sufficient to fill up unevenness in the surface, no single coat, however, shall exceed 12mm in thickness. The under coat shall be roughened or scratched before it is fully hardened. Curing shall start 24 hours after the plaster is laid. It shall be kept wet for 14 days. During this period it shall be suitably protected from all damages at the contractor's cost by such means as approved by the Engineer-in-charge. Any cracks which appear in the surface shall be cut out in rectangular shape and redone as directed by the Engineer-in-charge. Wherever specified standard waterproofing compound as approved by the Engineer-in-charge shall be added to the mortar at the rate of 2% or as specified by the manufacturer by the weight of cement for which the rate shall be paid separately. The rate for plastering shall include cost of scaffolding, swing etc., needed for the work with labour and material all complete.

9. Steel Door, Windows and Ventilators:

All steel doors, windows and ventilators shall conform to IS – 1038, IS – 1361 and IS 1081 or equivalent as mentioned in the bill of quantities and as approved by the Engineer-in-charge. Rolled steel sections shall conform to Is – 226. The sections shall be cold straightened and finished goods shall be free from bends and other defects. Materials used in the fabrication shall be the best procurable and conforming to relevant IS specification. Thickness and specification of the glass to be provided shall be as indicated

CIVIL ENGINEERING DEPARTMENT, BHEL, TRICHY-14

in the relevant item of the bill of quantities. Glass shall be free from flaws, specks, bubbles, etc., Bolts, nuts, screws, peg stays and other mild steel fittings shall be treated for corrosion as per relevant Indian Standards. Putty for glazing shall conform to IS – 420.

Doors, windows and ventilators, etc., shall be truly square and free from twist and warp. They shall be constructed of sections which have been cut to the required lengths and welded or riveted at the corners as per standard specifications.

All steel surfaces shall first be thoroughly cleaned free of rust scale or dirt and mill scale by approved means and shall be painted with one coat of approved primer conforming IS – 102 before despatch. Alternatively if specified they may be galvanised by the “Hot dip” zinc spray or electro galvanising process described IS – 1361. Doors, windows and ventilators shall be fixed in positions, as specified under IS 1081.

Whenever contractor is required to supply the doors, windows and ventilators etc., he shall first submit to the Engineer-in-charge, the details about source of supply, detailed drawing and specifications etc, for prior approval.

10. M.S Rolling Shutters :

It shall be of approved quality, made out of 18 gauge 75 mm black laths mechanically operated by reduction gear type mechanism. It shall be fitted with two self-aligning ball bearing with locking arrangements (both inside and outside) including M.S pressed side guides bottom rails brackets and top rolling spring pressed etc., complete provided with locking arrangements for padlocks, pulling hooks, handles, top cover etc., It shall be painted with one coat of approved primer conforming to Is – 102 before dispatch.

11. Wooden Doors, Windows and Ventilators:

All wood work for doors, windows, ventilators cup board, shelves, etc., conform to relevant IS specification and TNBP 82 and shall be well seasoned teak wood or well seasoned country wood (pillamarudu or karumarudu) as the case may be. Timber shall be best quality and shall be free from knots, injurious open shales, bore holes, decay, soft or spongy spots, hollow pockets and all other defects and blemishes. Timber shall conform to IS 1003 (Part 1). Size of doors, windows and ventilators shall as specified in the relevant item of schedule and detailed drawings and generally in conformity with IS – 1003, part I and part II. The rates for doors, windows and ventilators etc., shall be for the finished work inclusive of fixing them in position with necessary iron hold fasts and furniture fitting of oxidized iron or aluminium or oxidized brass as stated in the description of the relevant items of the bill of quantities and as directed by the Engineer-in-charge. Fittings and furniture shall be of best quality and machine made and robust type. Wherever glazed shutters are to be provided, the cost of glass panes of specified thickness and fixing them in position should be included in the quoted rate. All glass shall be of superior quality from approved manufacturer. In case of solid core flush doors, they should conform to IS: 2202 Part I and Part II. The flush door shutters should have a finished thickness as specified in the scheduled item. Flush door shutters shall be obtained from firms of repute as approved by the Engineer-in-charge.

12. ROOFING: (A) R.C.C Slabs:

Roof slab shall be of RCC of specified mix conforming to IS: 456, with adequate main tensile, transverse and adhesive reinforcement of ribbed steel bars of mild steel rounds. Unless otherwise mentioned the rates for RCC slab shall include cost of concrete, centering and shuttering charges, vibration charges, rounding of corners, curing and finishing etc., complete. Expansion joints in reinforced cement slabs shall be as per TNBP 30. The ceiling should be finished as per Clause 30 of TNBP. No extra payment shall be made towards cost of ceiling plaster necessitated on account of defective centering

materials used or poor workmanship.

The top of roof slab shall be finished with weathering course treatment if so specified. The weathering course work shall conform to TNBP 44-HJ and consist of concrete with broken brick in neat slacked lime of specified thickness finished with one course of pressed split tiles / pressed tiles of specified thickness and size as described in the bill of quantities.

(B) Roofing and Side Cladding with A.C. sheets:

The A.C. sheets shall be of specified and approved quality and shall conform to IS 459-1962 in all respects. The sheet shall be laid with the smooth side upwards and with a minimum end lap of 15cm. and for every flatter slopes this should be 20cm. The laying operation shall include scaffolding works involved. Sheets shall be secured to the purlins by means of 8mm galvanized iron J or L hook bolts and nuts. The grip of the hook bolt on the side of the purlin shall be not less than 25mm. Each bolt shall have a bitumen washer and galvanized iron washer placed over the sheet before the nuts are screwed down from above. Hole for hook bolts etc., shall be drilled and not punched in the ridges of the corrugations in the exact positions. The diameter of these holes shall 1.5 mm more than the diameter of the fixing bolts. The payment will be square metre basis of the laid area.

13. A.C. Rain Water Pipes

The pipes shall be of standard quality conforming to IS 1628. These shall be straight, true smooth and regular in thickness. They shall be free from cracks and other flaws. The supply shall include all necessary pipe fittings and accessories.

All pipes shall be fixed to wall or columns by standard M.S butt holder clamps of approved make. The spigot of the upper pipe shall be properly fitted into the socket of the lower pipe, such that there is uniform annular space for filling with the jointing materials. One third depth of this annular space is to be filled with spun yarn soaked in bitumen of approved quality and properly pressed with caulking tool. The remaining two, third depth of the joint is to be filled with Cement Mortar 1:2 (1Cement: 2 coarse sand) and shall be pressed with caulking tool and finished smooth at the top at an angle of 45 Deg. sloping up. The rate shall include supplying and fixing pipes with specials and accessories, including sizing as required, jointing, testing, cutting of walls and making good necessary scaffolding etc., complete.

14. Flooring:

Flooring shall consist of a base course of cement concrete of specified thickness and proportion laid over the compacted earth or sand filling as specified and a finishing layer of concrete, mosaic, glazed tiles or any other material as specified to be laid. Flooring work for Factory shop floors as well as mosaic flooring shall be done as per the special specifications. The bed flooring shall be prepared either level or sloped as per relevant drawing or as instructed by the Engineer-in-charge. Filling in basement with earth or sand shall be in accordance with TNBP 25. On the prepared bed, cement concrete of specified mix and thickness shall be laid and well consolidated.

A. Ellis pattern, 1st Sort Flooring

On the clean wet surface of the concrete base before it has set, will be laid a layer of cement concrete to give a finished depth of 20/25 mm over the base concrete. The cement concrete will be of 1:3 proportion (one cement and 3 hard broken stone chippings 3 to 10 mm Size). To make a coloured floor red oxide iron powder or other approved materials should be mixed with cement at the rate 10% of the weight of cement or as directed by the Engineer-in-charge. Ellis pattern flooring shall be done as described under clause 41-G of TNBP.

B. Glazed Tile Flooring

The tiles shall be of ceramic white or coloured and of specified dimensions as described in the schedule item. The top surface of tiles shall be glazed with a neat finish of uniform colour and texture and free from flaws, cracks, craze, specks or other imperfections. Tiles shall be true and shape with straight edges, non-absorbing and non – fading. Samples of

tiles together with manufacturer's literature shall be submitted to the Engineer-in-charge for approval. Tiles shall conform to IS 177 latest.

Over the prepared surface of the floor a bedding layer of Cement Mortar (1:3) of specified thickness shall be laid-in-proper level and slope using screed patterns. The bedding layer shall be deeply scratched while it is set. A mortar set bed of 6mm thickness incement lime mortar 1:1:3 (one cement one lime putty and three sand), shall be laid over the bedding layer. After mortar setting, bed has been leveled, a skin of neat cement shall be trowelled to the mortar setting bed immediately before the tiles are set. As soon as the mortar setting bed has sufficiently hardened, all tiles shall be finally secured in place and gently beaten in and finished surface brought to desired level. When grouting the glazed tiles, special care shall be taken to prevent scratching of the glazed surface. Joints shall be pointed with white or coloured cement to match the tile surface and cured. No joint shall be more than 1.5 mm thick.

15. White Washing and Colour Washing

White washing and colour washing shall be done as per clauses 63 and 64 of TNBP. The surface shall be thoroughly cleaned off mortar drops and foreign matter. All patchings must be scraped properly. The white washing shall be done from pure shell lime / Janathacem. Samples of lime shall be got approved by the Engineer-in-charge. The wash shall be applied with a brush, the coats being laid on vertically and horizontally alternatively, each coat being allowed to dry before next coat is applied. For colour washing the desired shade shall be obtained by mixing approved quantity of colouring matter or distemper with shell lime solution and applied as per white. The contractor shall take every precaution to prevent white wash being splashed on wall, floor and other places and articles not to be white washed. No colour wash shall be done unless a sample pattern of the mixed colour has been approved by the Engineer-in-charge. The rates shall be inclusive of scaffolding charges, cost of ladder etc,

16. Painting

All painting work shall be done in accordance with TNBP-66 and the relevant Indian Standard Specifications. Paints, varnishes, cement paints etc., shall be the highest grade products of well known approved manufacturer and shall be delivered to site in original sealed containers. It is desired that materials of one manufacturer only shall be used as far as possible. Colours shall be uniform and nonfading. Samples of all colours selected shall be submitted to the Engineer in charge for approval before bulk purchase is made. All finished work shall match corresponding samples kept with the Engineer.

Preparation of Surface:

Before painting wooden surfaces, protruding timber fibres shall be removed and nail marks shall be covered with putty. The surface shall be thoroughly cleaned and sand prepared. In case of steel work it shall be scraped, well brushed and cleaned free of rust, scale dirt. Base preparation for painting concrete, masonry and plastered surfaces shall be carried out as per IS 2395 – Part I. Before actually proceeding with the work of painting the concrete, masonry and plastered surfaces, it shall be verified that the surfaces shall be completely dry, free from efflorescence and alkaline effect.

Application

The primer shall be applied with brushes and spread as evenly and as smooth as possible. For steel work a priming coat of Red Oxide / Zinc Chromate paint shall be applied. Painting shall be done by skilled labourers in a work-man like manner. All coats shall be of proper consistency and shall be well brushed out, so that no brush marks are visible. The under coating should be nearest to the specified colour of the finishing coat. Unless otherwise

CIVIL ENGINEERING DEPARTMENT, BHEL, TRICHY-14

specified ready mixed synthetic enamel paints shall be used for painting, wood and steel work. Under coats should be completely dry before finishing coat is taken up. Priming coat and under coat shall be rubbed with sand paper and dusted clean. The finished coat of approved paint shall then be applied.

17. Cement Painting

Cement Paint solution shall be applied to the surface with hair brushes in a number of coats to get uniform finish. After the first coat of paints has hardened, it shall be cured with water atleast for 24 hours. The surface shall be wetted again before the application of the second coat. Atleast 24 hours should lapse between the two coats, number of coats shall be as specified in the schedule of quantities. It shall be kept damp atleast for seven days.

18. French Polish

French polish to be used shall comply with IS 348. Polishing shall be obtained by dissolving 1 lbs, of shellac in one gallon of methylated spirit without applying any source of heat. After the shellac has dissolved ¼ lbs of cobalt, ¼ lbs of lobano and 0.4 oz of crystals of desired pigment shall be added. The solution shall be applied with a pad of fine muslin cloth tied as per general practice. The pad shall be dipped into the solution and wrung with fingers and be rubbed hard on the surface in this way, the first coat is to be given after this gets dried up, the successive coats shall be given in the same fashion till the mirror like surface is obtained. The wood to be polished shall be first applied with a filler composed of 1.25 Kg. of whiting mixed with one litre of methylated spirit and then sand papered when dry. The finished surface shall have uniform texture and gloss. Approved transparent sealer shall only be used in base preparation.

SPECIAL SPECIFICATION FOR CONTROLLED CONCRETE

a) PROPORTIONING MIX:

The proportion of aggregate, Cement and water to be used for controlled concrete shall be designed by preliminary tests of the materials to be actually used to obtain the densest to workable concrete requiring the minimum quantity of cement paste for binding the materials to give the required strength. However the maximum total quantity of aggregate by weight per 50 kg. of cement shall not normally exceed 450kg All proportions shall be by weight. However water may be added by weight or volume.

b) MIX DESIGN:

Immediately upon the receipt of the award of the contract, the Contractor shall inform the Engineer-in-charge the exact location of the sources of materials which he proposes to use and get the materials approved. The mix with the actual approved materials to be used shall be got designed by the Contractor in an approved laboratory chosen by BHEL and got approved by the Engineer-in-charge. These proportions shall be used so long as the materials continue to be the same quality and from the same sources. If during the progress of work, the Contractor wishes to change the materials, the proportions shall be fixed on the basis of fresh preliminary tests to give the required strength. No change of materials shall be allowed unless fresh tests with new materials show satisfactory results.

CONTRACTOR

60

ACCEPTING OFFICER

c) STRENGTH REQUIREMENTS OF CONCRETE:

Controlled concrete shall be in the following grades, M 15, M 20, M 25, M 30, M 35 & M 40. The concrete mix shall be designed to produce the grade of concrete having the required workability and characteristic strength not less than the appropriate values (as per I.S. 456) as given in table below:

Sl. No	Grade of. Concrete	Specified Characteristic Cube Strength	
		Preliminary test N/mm ²	Works test N/mm ²
1.	M 15	20	15
2.	M 20	26	20
3.	M 25	32	25
4.	M 30	38	30
5.	M 35	44	35
6.	M 40	50	40

d) WORKABILITY OF CONCRETE:

The proportions chosen shall be such that the concrete is of adequate workability for the conditions prevailing on the work in question, and shall be properly compacted. Water shall be added to the mixer to give the required workability. The water content of each batch shall be adjusted as necessary to maintain the required workability with simultaneous adjustment of cement concrete such that the water cement ratio is not changed. The workability tests shall be carried out in accordance with IS : 1199 - Latest, "Methods of sampling and analysis".

Workability of concrete shall be controlled by direct measurement of water content, making allowance for any surface water in the fine and coarse aggregates. Allowance shall be made for surface water present in the aggregate when computing the water content. Surface water shall be determined by one of the field methods described in IS : 2386, Part III.

e) CONSISTENCY AND SLUMP:

The concrete shall have a consistency such that it will be workable in the required position. It shall be of such consistency that when properly vibrated it will flow around reinforcing steel and all embedded parts. The slump for concrete as determined by slump tests as per Indian Standard 456 (latest edition) shall not exceed the maximum slumps indicated below for each type of construction as approved by the Engineer-in-charge.

Workability	Slum in MM		Type of Construction
	Min.	Max.	
Medium	40	80	All RCC works

CIVIL ENGINEERING DEPARTMENT, BHEL, TRICHY-14

The contractor shall not place concrete having a slump outside the limits specified without the approval of the Engineer-in-charge.

Atleast one slump test shall be made for every compressive strength test carried out. More frequent tests shall be made if there is a distinct change in job conditions or if required by the Engineer-in-charge.

f) TESTS:

Test shall conform to the specifications laid down in IS : 456. These tests shall be got done in an approved laboratory and in accordance with IS : 516 - Latest at the cost of the Contractor (for making necessary cube moulds, transporting the cubes to the Laboratory and all other incidental etc.). The test fees for the cubes shall be borne by the contractor. In order to ensure proper quality control sampling of the concrete of each specification placed on any day in work shall be done in accordance with the following table.

Quantity of Concrete in work	Total Number of samples(each sample to consist of 6 test cubes)
Upto 5.00 Cu.m.	1
Greater than 5.00 Cu.m.and less than 15.00 Cu.m	2
Greater than 15.00 Cu.m.and less than 30.00 Cu.m.	3
Greater than 30.00 Cu.m.and less than 50.00 Cu.m.	4
Greater than 50.00 Cu.m.	4 + one additional sample for each additional 50 Cu.m. or part thereof.

i) The sampling shall be spread as evenly as possible throughout the day. When wide changes in weather conditions occur during concreting, additional samples may be taken as desired by Engineer-in-charge. Each sample shall consist of 6 cubes of 15 x 15 x 15 cm concrete. Test cubes shall be kept immersed in water until required for test which will be usually at 7 days and minimum crushing strength of not less than the following:

Grade of Concrete	M15	M20	M25	M30	M35	M40
Crushing strength in N/mm ² at the end of						
a) 7 days	10	13.50	17	20	23.50	27
b) 28 days	15	20	25	30	35	40

CONTRACTOR

62

ACCEPTING OFFICER

CIVIL ENGINEERING DEPARTMENT, BHEL, TRICHY-14

All costs connected with the preliminary tests for proportioning the mix, sampling, curing, handling, other incidental charges, labour charges and cost of materials shall be borne entirely by the Contractor. Testing charges for cubes (work tests) shall be borne by contractor. Such testing shall normally be conducted at the BHEL Central Laboratory or any other approved laboratory as directed by the Engineer-in-charge.

All samples for tests shall be taken in the presence of Engineer-in-charge and the Contractor or his authorised agents.

A set of six specimens from random mixer batches, shall constitute a test, three being tested for 7 days and three being tested for 28 days strength.

The strength test result shall be the average strength of the three companion test specimens, tested at 28 days, except that, if one specimen in a test shows manifest evidence of improper sampling, moulding or testing, the result shall be discarded and the remaining two strengths averaged.

ii) Normally, 7 days and 28 days tests shall be made on specimens. For any mix, a correlation between 7 days and 28 days strengths may be made in the laboratory. Soon after a job starts, a similar correlation will be evolved for samples of a concrete taken from the mixer. After that correlation has been established, the results of the 7 days test may be used as an indicator of the compressive strength which should be expected at 28 days, provided such results are consistent, if 7 days tests shown compressive strength that are too low, corrective measures shall be taken at once, at the Engineer's direction, without waiting for the results of the 28 days tests.

iii) Each class of concrete shall meet the following strength requirements:

The average of any three consecutive strength tests shall have a value equal to or greater than the specified strength subject to the condition that only one out of three consecutive tests may give a value less than the specified strength but this shall not be less than 90% of the specified strength.

iv) In the event that concrete tested in accordance with the requirements of this specification, fails to meet the requirement, the Engineer shall have the right to require any one or all the following.

1. Changes in the concrete mix proportions for the remaining work.
2. Curing and testing of the concrete represented by the tests which failed.
3. **Replacement of any such portions of the structure. (No payment for dismantled concrete, associated from worker or reinforcement shall be made. Embedded fixtures, reinforcement and adjoining structures, damaged during dismantling shall be made good by the Contractor at his own expense).**
4. Extended curing of the concrete represented by the specimen.
5. The contractor shall carry out all such measures as directed at his own expense.

CIVIL ENGINEERING DEPARTMENT, BHEL, TRICHY-14

Load tests of structural members may be required by the Engineer when the strength of the job control tests falls below the required strength and is not acceptable as per "Acceptance Criteria" stated earlier. The entire cost of the load test shall be borne by the Contractor. If the load testing is decided by the Engineer, the member under consideration shall be subjected to a superimposed load equal to one and quarter (1.25) times the specified superimposed load used for design and this load shall be maintained for a period of 24 hours before removal.

The detailed procedure of the test shall be decided by the Engineer-in-charge.

If, within 24 hours of the removal of the load, the structure does not show a recovery of at least 75 percent of the deflection after the 24 hours under load, the test should be repeated. The structure should be considered to have failed to pass the test if the recovery after the second test is not at least 80 percent of the maximum deflection occurring during the second test.

If the member shows evident failure, such changes as are necessary to make the structure adequately strong, shall be made by the contractor free of cost to the Department. If on the other hand, the failure becomes apparent, the Engineer under special circumstances, can retain the portion of the structure under test, provided suitable strengthening and or load dispersed arrangement is feasible. Cost of such strengthening or load dispersed arrangement shall be borne by the Contractor.

Load test shall not be made until the expiry of 56 days of effective hardening of the concrete.

If a portion of the structure is found to be unacceptable it shall be dismantled and replaced by a fresh structure as per specification. The cost of such dismantling and reconstruction should be borne by the Contractor.

The proportions of cement, fine aggregate, coarse aggregate and water necessary to produce a concrete mix which will fulfill the requirements of this specification for each grade of concrete shall be determined on the basis of trial mixes conducted with the samples of the material to be used in the work by the Engineer-in-charge in the field Laboratory.

All mix design and test data and results shall be maintained as part of the record of the contract and shall be signed by the Engineer-in-charge and the Contractor. A register showing such record shall be maintained at site of work as shown below.

CIVIL ENGINEERING DEPARTMENT, BHEL, TRICHY-14

NAME OF WORK:

Sl. No.	Date & Time	Sample No.	No. of Cubes	Identification marks	Proportions of mix	Description of portion of work represented by sample and quantity of concrete represented by the sample	Initials of S.O/A.E. in whose presence sample is taken	Date of test
(1)	(2)	(3)	(4)	(5)	(6)	(7)	(8)	(9)

7 days test result of each cube	Average 7 days strength	Standard 7 days strength	Date of test cube	28 days last result of each cube	Average 28 days strength	Standard 28 days strength	Remarks (the reference Nos. of test report should also be recorded here)	Review and Remarks by Asst. Engineer	Review and Remarks by Executive Engineer
(10)	(11)	(12)	(13)	(14)	(15)	(16)	(17)	(18)	(19)

CONTRACTOR

ACCEPTING OFFICER

SPECIAL CONDITIONS OF CONTRACT

STRUCTURAL STEEL WORKS

1. Broadly, the work under this contract comprises of conveying of raw structural steel sections (issued at free of cost by BHEL) from Contractor's Store to site fabrication shop, fabrication of steel work at the site fabrication shop including one priming coat of Zinc Chromate / red oxide primer, transportation of fabricated steel structures to the erection site including loading, unloading, leading, stacking as required and all handling costs, erection of steel work over prepared foundations or on RCC brackets as the case may be and painting of steel work two coats with approved synthetic enamel ready mixed paint or as specified in the Bill of quantities carrying from Contractor's stores and erection of cloaking items etc. complete.
2. The Contractor may also be required to supply some raw structural steel sections also as required for this work in accordance with the latest editions of the Indian Standard Specifications noted below:-

IS 2062 & IS 1977. He will be required to submit the necessary test certificates for the materials so supplied for use on this work.
3. The detailed fabrication drawings as approved for fabrication will be the responsibility of BHEL. The Detailed Shop Drawings will be supplied by BHEL to the contractor progressively to suit the fabrication and erection sequence. The Contractor shall not depart from the drawings approved by BHEL without the written permission of the Engineer-in-charge.
4. Based on the detailed shop Drawings approved by the BHEL the Contractor shall prepare at his cost, the Drawing Office Despatch Lists (abbreviated as D.O.D.L.'s) and get them approved by BHEL. These shall contain the drawing number, the designation of items, number of pieces, based on the section weights as adopted for supply of raw materials without deduction for bolt holes and skew cuts. The DOD Lists shall form the basis for payment.
5. Rate quoted against item(s) of the Bill of Quantities cover the fabrication of all items involved and shall therefore be an Overall-average-rate. The actual quantities for payment shall be based on the drawing office despatch lists to be prepared by the Contractor and got approved by BHEL as aforesaid.
6. All Civil works like preparation of foundations for columns, including embedding of holding down bolts etc., also have to be carried out and hence included in the present enquiry. All works shall be performed and completed in a thoroughly workmen like manner and the contractor shall follow the best modern practice in the manufacture of high grade structures notwithstanding any omission in the specifications.
7. (a) Fabrication shall generally be in accordance with IS 800 (latest issue) entitled "Code of practice for use of structural steel in general building constructions". Welding shall be in accordance with IS 816 entitled "Code of practice for use of metal arc welding for general construction in mild steel". The

CIVIL ENGINEERING DEPARTMENT, BHEL, TRICHY-14

contractor shall provide necessary splicing as approved by the Engineer-in-charge, to suit the available lengths of raw steel, and no extra amount shall be paid on this account. Any specifications not covered by the Relevant Indian Standard Codes of practice shall be in accordance with the relevant BS or in its absence in accordance with the well-established standard Engineering practice to be acceptable to BHEL.

(b) Under the contract, site fabrication is to be adopted for which a suitable site near and inside the factory premises will be made available by BHEL at free of ground rent. The Contractor shall provide all plant and equipments, tools covered sheds and other facilities required for site fabrication work at his own cost.

(c) The Contractor shall take into consideration the existing foundation structures and make necessary provisions in the fabricated components with the approval of the Engineer-in-charge so that proper alignment, vertically and easy connection / erection of structures is ensured.

8. All fabricated steel work shall be given one coat of Red Oxide / Zinc Chromate primer conforming to Relevant IS code before erection. All fabricated steel work shall be match marked suitably to facilitate their erection in position without any difficulty.
9. Materials supplied by the contractor shall be in standard / random sizes / lengths. Hence the Contractor will be required to supply extra materials to cover conversion, wastage, alteration etc. He shall do so without any claim for extra payment, whatsoever on this account.
10. All breakages after the A.C. materials brought inside site by the contractor shall be to Contractor's account. As far as possible partially broken A.C. materials should be cut suitably and used for smaller sizes with the approval of BHEL, without any extra claim.
11. The Contractor should prepare in advance cutting lists for materials so as to obtain efficient and economical use of all types of materials including steel.
12. Normally no night work will be permitted. But in case of emergency and urgent in nature where night work is warranted, the Contractor shall arrange for night works providing all facilities including illumination at his own cost, after obtaining written permission from Engineer-in-charge under intimation to Security and Safety Departments.
13. The Contractor shall closely scrutinize all the drawings for the work issued by this organization and bring to the notice of the Engineer-in-charge any discrepancies / omissions noticed in the drawings before undertaking the actual work.

CONTRACTOR

67

ACCEPTING OFFICER

CIVIL ENGINEERING DEPARTMENT, BHEL, TRICHY-14

14. M/s BHEL through their duly authorized representative shall have all reasonable times access to the Contractor's premises or works and shall have the power at all reasonable times to inspect any portion of the work or examine the materials and workmanship of the structures during their manufacture and test. The Contractor shall give notice in writing to the inspecting Engineer of BHEL when the materials to be supplied are ready for inspection and test, no materials shall be used on the fabrication work until the inspecting Engineer has certified in writing that such materials have been inspected and approved by him. The contractor shall provide at his own cost all facilities for the required tests on fabricated structures as required by the Engineer-in-charge. Defective fabrication structures shall be made good / replaced by the Contractor at his own cost to the full satisfaction of BHEL. **This also applies to loss or damage of raw materials, if special tests only will be borne by BHEL.**
15. Weekly progress reports shall be submitted giving in detail the position of receipt of raw materials, progress of fabrication and completion of fabricated structures etc. The contractor shall submit at such times as may be requested by the Engineer-in-charge, schedules showing the programme and order in which the Contractor proposes to carryout the fabrication and erection works with dates and estimated completion times for various portions of the work. Such schedules shall be approved by the Engineer-in-charge prior to the starting of the relevant works.
16. BHEL would expect the contractor to take up simultaneously wherever possible both fabrication and erection of structures especially where a good deal of assembly work, which is in fact a continuation of the fabrication work, is required to be done at site. The painting and cloaking items of works, wherever possible, should be done simultaneously to save time. **The Contractor may with the prior approval of BHEL sublet the work.** The main contractor shall however, be responsible for all works executed on his behalf by the sub-contractors.
17. **SETTING OUT AND ERECTING OF STEEL WORK:**
 - a) Erection of steel work shall generally be in accordance with the provision of IS 800 (Code of practice for use of structural steel in General Constructions).
 - b) Site assembly of members on the ground by welding, bolting or otherwise as specified in shall be inspected thoroughly by the Engineer-in-charge, or his authorized representative and approved before erection.
 - c) All equipment's, facilities and consumables for site fabrication as well as erection plant requirement, etc., such as derricks, cranes, lifting tackles, wire ropes, chain pulley blocks, jacks, winches etc. as necessary shall be arranged for by the Contractor at his own cost. Care shall be taken to see that all equipment's, tools and tackles and wire ropes etc. in use are always in good working conditions and fit for use. For all the tools and plants periodical calibration certificate from approved agency should be obtained. **The above lists should be enclosed along with the tender.**

CIVIL ENGINEERING DEPARTMENT, BHEL, TRICHY-14

- d) Frames shall be lifted at such points that they will not buckle or deform. Trusses shall be lifted only at nodes. Temporary bracing shall, if required, be provided at no extra cost, to relieve erection stresses.
- e) In the case of trusses and similar roof structures all or at least a majority of the purlins and wind bracings, shall be erected side by side with the erection of these structures. Columns shall be erected true to plumb, (no screed bars provided and fixed by the Contractor over the prepared pedestals), true to center line, level and gauge of traveling cranes. Alignment of the columns, crane girders and rails shall be done very carefully using high precision survey instruments and necessary adjustments made to suit actual requirements. **A list of survey instruments proposed to be used shall be furnished in the tender.**
- f) All damages to the steel work caused during the transit or otherwise shall be made good to the full satisfaction of BHEL at Contractor's own cost, before erection.
- g) It shall be the sole responsibility of the Contractor to ensure accuracy of level, plumb, span and alignment of steel work before erection of other components.

18. PAINTING AFTER ERECTION:

- a) All steel work shall be given two coats of approved brands of first quality synthetic enamel ready mixed paint after erection (over the priming coat already provided). Painting shall be done as per IS 800. The shade, make, quality and other particulars of the paint proposed to be used, shall be subject to prior approval by BHEL.
- b) It is the responsibility of the Contractor to procure sufficient quantities of the approved paints well in advance to ensure their availability in time.

19. TIME ALLOWED (Period of Contract)

The following programme should be strictly followed.

- (i) Fabrication of structural steel works } Progressively from the date of award of
to be completed } work
 - (ii) Erection, painting of the above } Progressively from the date
on
structures, supply and erection of } which completion of civil work and
cloaking items etc. to be completed } the readiness of site declared as fit for
} erection
20. The contractor will have to provide and fix the necessary screed bars etc. at his own cost in proper line, level and position to facilitate the erection work. Further, the contractor should lay and maintain necessary temporary approaches within his working areas at his own cost to facilitate his work and for easy movement of

CONTRACTOR

69

ACCEPTING OFFICER

CIVIL ENGINEERING DEPARTMENT,BHEL,TRICHY-14

vehicles, cranes etc. deployed on the work. **Only reasonable areas will be provided by BHEL.**

21. Till the expiry of the maintenance period after the completion of the entire contract work and handing over to BHEL, the contractor should retain the minimum equipments and staff required and should carry out the maintenance works with the least possible interference to the routine works of the new shop. Till the expiry of the maintenance period the contractor shall be responsible for all damages occurring due to any fault on his part or on the part of his workmen, sub-contractor or other agencies engaged by him.
22. BHEL shall have the right to take possession of or use any completed or partially completed part of the work. Such possession or use shall not be deemed to be acceptance of any work not in accordance with the contract.
23. The contractor shall observe all safety regulations and take necessary safety precautions as called for under the Factories Act or other relevant statute as applicable including the use of safety boots, safety belts, helmets and other equipments and accessories for ensuring safe execution of the contract and freedom from accidents.
24. The rates quoted in the Bill of Quantities of the tender for the fabrication item shall cover also the cost of preparation of DODL and similar incidental items. Fabrication works shall be undertaken only after the issue of approval of shop drawings.
25. The Contractor should co-operate with other contractors who may be executing their work in the same area in order to facilitate efficient execution of the entire project work in this area.
26. **BHEL is registered as an indentor for materials on rate contract with DGS & D. Tenderers who are on DGS & D List of rate contracts should mention their rate contract number and furnish a copy of the rate contract document with the tender.**
27. The Guarantee / Warranty period for this contract shall be **SIX MONTHS** from the date of completion of the entire work and handing over to BHEL. During this period the successful tenderer shall be at site on his own expense for replacement or repair of all defects arising out of faulty materials and / or workmanship.
28. Further particulars relating to design and fabrication and clarifications, if any, may be obtained on reference to the Sr. Manager / Designs / Civil / Factory, BHEL, Tiruchirapalli-14 or his nominee.
29. The contractor shall engage a level-II NDT Inspector for inspection of NDT works.
30. Inspection will be done by BHEL Staff / Agencies appointed by BHEL for the works covered in the tender.
31. Painting, DFT of primer should be 25 micron.

CONTRACTOR

70

ACCEPTING OFFICER

CIVIL ENGINEERING DEPARTMENT,BHEL,TRICHY-14

32. Finish coat Painting, DFT 20 micron for each coat. Paint shall be of first quality product of approved brand as per list of approved brands for materials enclosed in the price bid.
33. Pre heating and post heating required shall be as per AWS (latest).
34. Welder qualification is to be done before commencement of the work and approved & qualified welder only shall be engaged in the work. Necessary testing charges shall be borne by the contractor.
35. For the supply of material the manufacturer's test certificate is to be produced.

CONTRACTOR

71

ACCEPTING OFFICER

GENERAL QUALITY CONTROL PROCEDURE FOR STRUCTURAL STEEL WORKS

The following quality standards are required to be maintained in all the structural steel fabrication components.

1. All the raw materials will be generally conform to IS 2062-1999 or equivalent.
2. The welding electrodes shall be kept in oven only.
- 3a. Submerged Arc welding has to be done for crane girder flange to web joints and built up column as per the details given in the approved drawings.
- 3b. E7018 Welding electrode rods shall be used where the thickness of plates are 20mm and more and as specified in the drawings issued.
- 3c. All the other weld in crane girder and butt welds in columns and beams shall be done with E 7018 welding electrodes.
- 3d. All the welds in Nodal points of trusses and lattice girders shall be done with E 7018 welding electrodes.
4. Pre heating shall be done for plates having thickness 25mm & more and the temperature shall be maintained by checking with thermal chalk, as per quality standards.
5. All erection welding, of any component shall be done using E 7018 Welding Electrode.
6. 100% visual check shall be carried out for raw materials and welding on all components and the welding areas during inspection, to be tested for LPI / MPI / UT / Radiography / PWHT as provided in the Quality Control Procedure.
7. Base plate to column shall be perfectly checked for perpendicularity.
8. All the components shall be checked for dimension at fit-up stage itself before the commencement of welding operation.
9. Contractor shall buy & use Black Hex. bolts and nuts as per IS Specifications as detailed below for fabrication & erection of steel structures.

Black Hex Bolts	IS 1363 - 1984 Part – I (Class 5.6/5.8)
Black Hex Nuts	IS 1363 - 1984 Part - III
Plain MS washer	IS 2016 - 1975
Taper washer for beams	IS 5274 - 1975
Taper washer for channel	IS 5372 - 1975
Spring washer	IS 3063 - 1964
10. Contractor shall buy & use the following welding consumables as detailed below:

a)	SMAW No.	Electrodes	Manufacturer
	1.	E 6013 & E 7018	D & H Secheron
	2.	E 6013 & E 7018	ESAB India Ltd.
	3.	E 6013 & E 7018	Modi Arc Electrode Co.
	4.	E 6013 & E 7018	D & H Welding Electrode (I) Ltd.
	5.	E 6013 & E 7018	MantekElectrods (P) Ltd.
	6.	E 6013 & E 7018	Ador Welding Ltd.
	7.	E 6013 & E 7018	Varun Electrodes Pvt. Ltd.

CONTRACTOR

ACCEPTING OFFICER

CIVIL ENGINEERING DEPARTMENT, BHEL, TRICHY-14

b) SAW Wire

Sl.No.	Brand	Manufacturer
1.	AUTO melt Grade A	Ador Welding
2.	Mantek Grade A	Mantek Wires
3.	Metaspool S1 dia. 4mm	Precision Wires
4.	OK Aut Rod 12.08 L	ESAB India Ltd.

c) Flux

Sl.No.	Brand	Manufacturer
1.	Super S41	Super Eleclnds
2.	Mantek 22	Mantek Welded Flux Co.
3.	RMH Auto Weld Grade 1	RMH Chemicals
4.	SWP 40 T	Super Weld Prod

d) GMAW (Co2)



Electrode	Brand	Manufacturer
ER70S-6 Co2 WIRE	Automig-1	Ador Welding Ltd.
ER70S-6 Co2 WIRE	Esab MW1	Esab India Ltd., Chennai
ER70S-6 Co2 WIRE	MantekMig	MantekWiress
ER70S-6 Co2 WIRE	Nouvarc	Nouveax Industries (P) Ltd., Kangayam
ER70S-6 Co2 WIRE	Autofil-6	Voltrac Electrode Pvt. Ltd., Tirupathi.
ER70S-6 Co2 WIRE	Prima Mig/Mag	Varun Electrodes Pvt. Ltd., Panipat.

11. Rolled steel sections of depth greater than 450mm need to be visually checked for lamination before the process of fabrication. The doubtful area to be tested for LPI and if lamination is found UT Test to be carried-out.
12. The welding code of practice, procedures, specifications for electrodes / consumables etc., for manual welding and auto welding shall conform to AWS D1.1/D1.1M:2006 (Latest) and as per the QCP issued by BHEL component-wise.
13. All the fabrication and erection works shall have to be executed as per the QCP issued by BHEL.
14. All the fabrication and erection works will be inspected for Quality Control by a third party inspection agency as fixed by BHEL.

CONTRACTOR

73

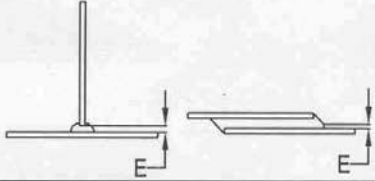
ACCEPTING OFFICER

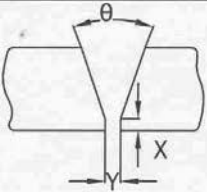
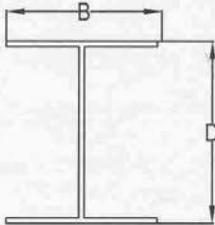
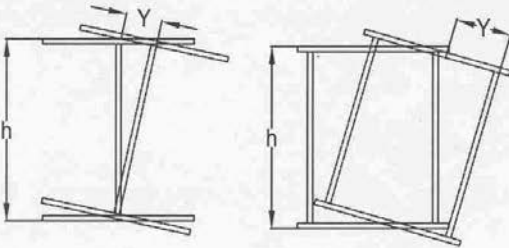
DESIGNATION	DETAIL OF SKETCH	PERMISSIBLE DEVIATION
FILLET WELD FIT UP	FIG:2 	MAX.LOCALISED GAP = 1.5mm
BUTT WELD	FIG:3 	CUT OF ALIGNMENT = 3 mm MAX
FIT UP	FIG:4 	FOR ,X, Y, θ REFER = 1.2 & 3 OF CL 7:4:3
SECTION SIZE	FIG:5 	D: UPTO 1M : ± 3mm 1M TO 2M : ± 4.5mm OVER 2M : + 7.5 mm - 4.5mm B: ± 3mm
TWIST ON SECTION (Y)		Y=0.005h 10 mm MAX

LINE OF FLAME HEATING

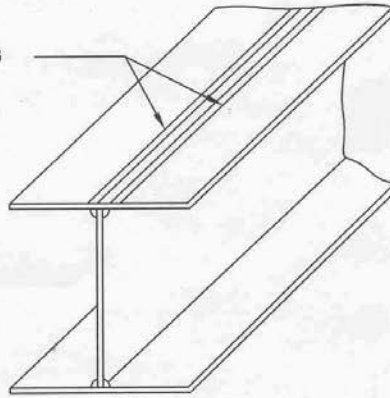
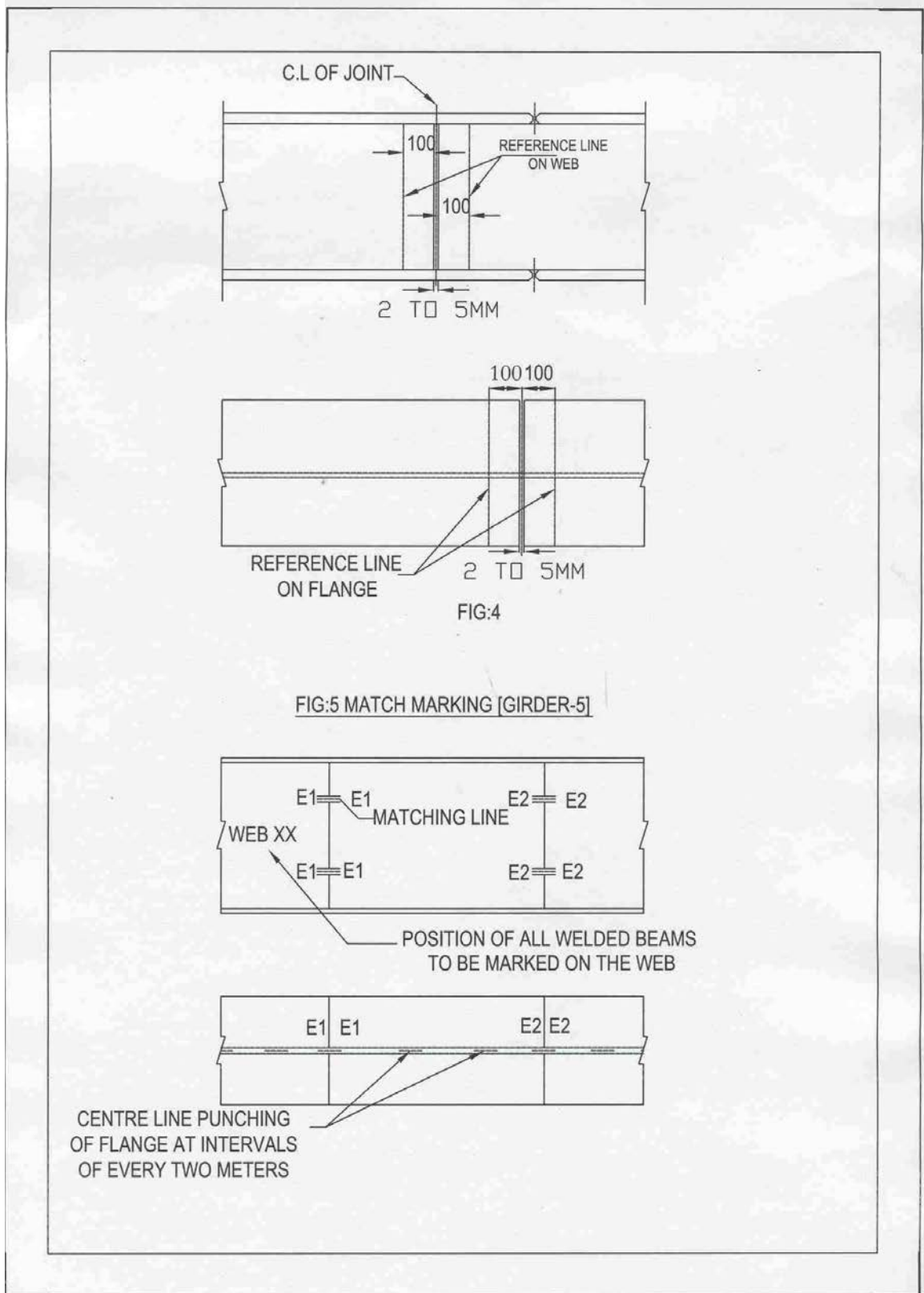
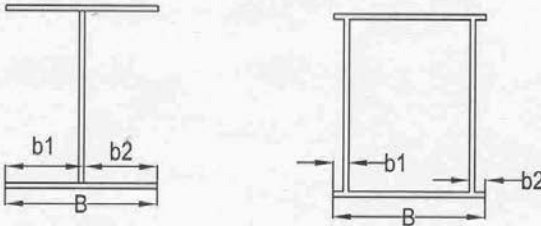
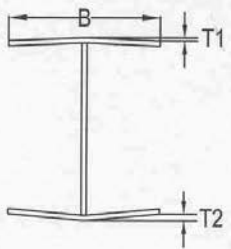
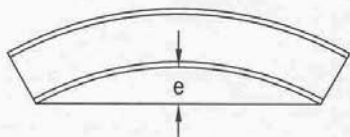

FIG:1

CORRECTION OF FLANGE WARPAGE

DESIGNATION	DETAIL OF SKETCH	PERMISSIBLE DEVIATION
WEB SHIFT	<p>FIG:2</p> <p>The diagram shows a T-section with a total flange width 'B'. The web is centered, and the distance from the web centerline to the left edge of the flange is 'b1', and to the right edge is 'b2'.</p>	$\frac{b1 - b2}{2} = 2\text{mm}$
FLANGE WARPAGE	<p>FIG:3</p> <p>The diagram shows a T-section with a total flange width 'B'. The top flange is curved upwards, and the bottom flange is curved downwards. The maximum upward curvature is labeled 'T1' and the maximum downward curvature is labeled 'T2'.</p>	$T1 + T2 = \frac{B}{100} \text{ OR } 6\text{MM}$



DESIGNATION	DETAIL OF SKETCH	PERMISSIBLE DEVIATION
<p>WEB SHIFT</p>	<p>FIGURE-7</p> 	$\frac{b1 - b2}{2} = 2\text{mm MAX}$
<p>FLANGE WARPAGE</p>	<p>FIGURE-8</p> 	$T1 + T2 = \frac{B}{100} \text{ OR } 6\text{MM}$
<p>CAMBER</p>	<p>FIGURE-9</p> 	<p>$E = 1/1000 \times \text{length}$ SUBJECT TO MAX] OF 10mm.</p>

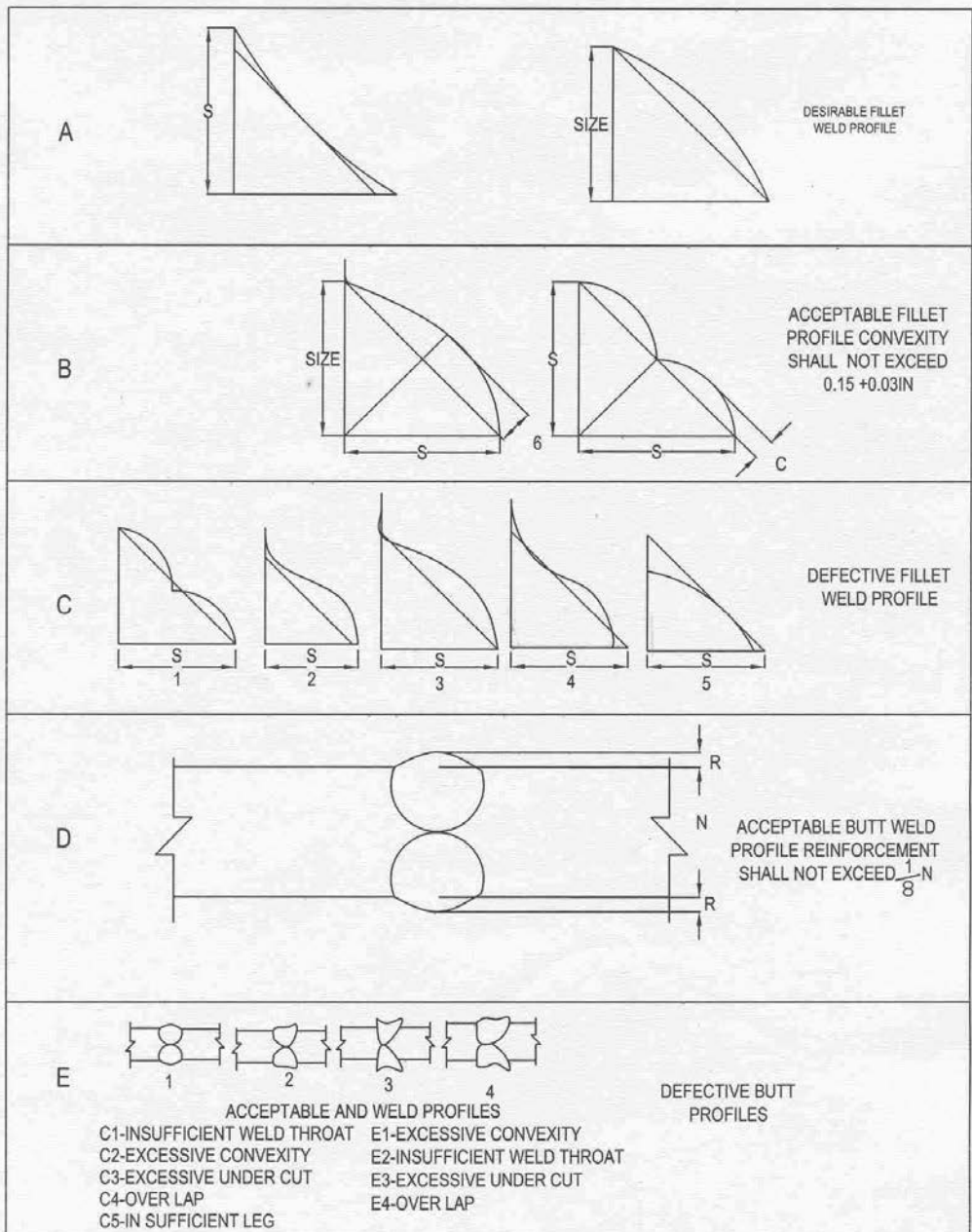

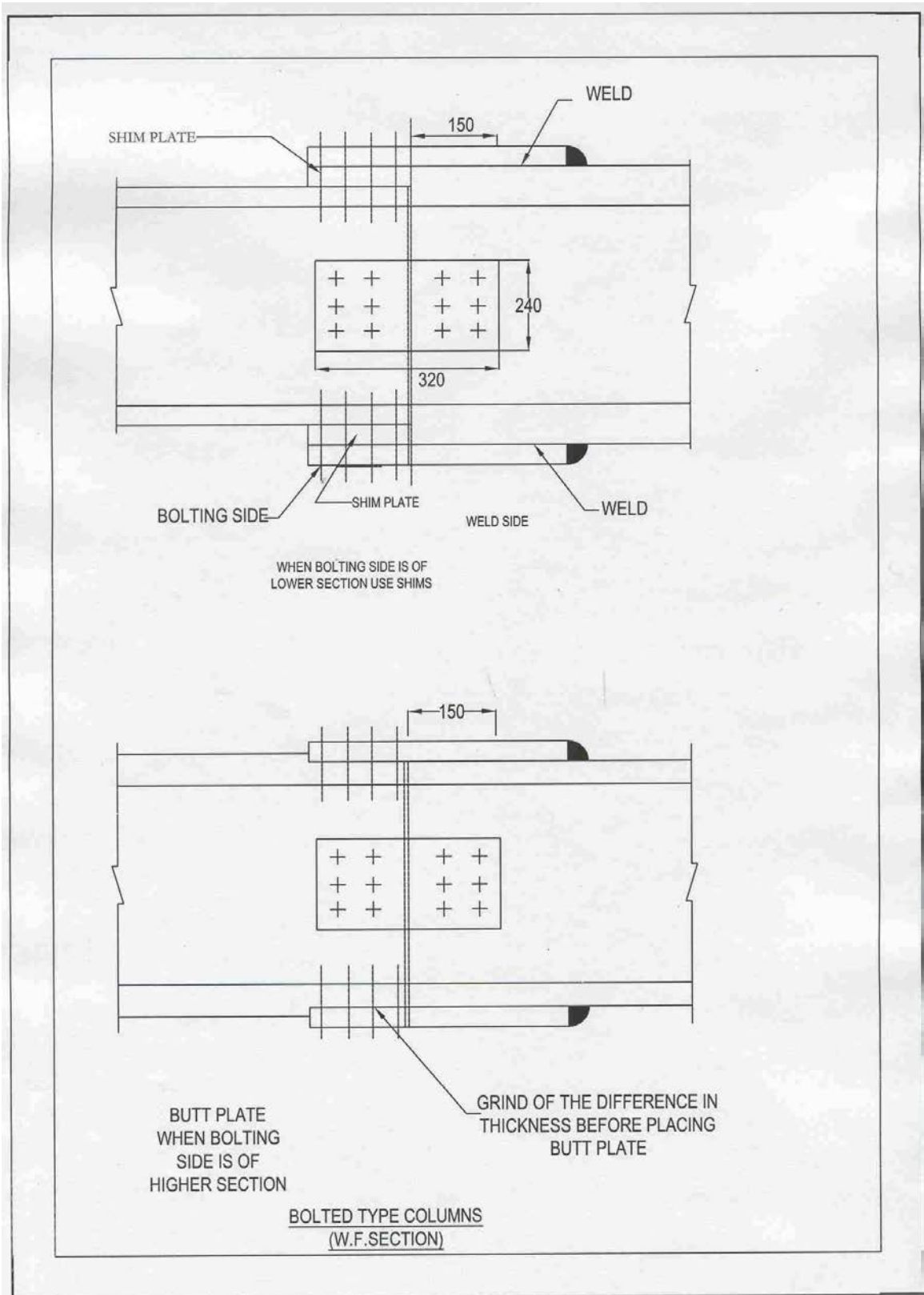

BHEL APPROVED BRANDS FOR THE FOLLOWING MATERIALS / ITEMS

Sl.No.	Material	Manufacturing Co.	Brand
1.	Synthetic Enamel Paint	Asian Berger ICI	Apcolite Luxol Dulux gloss
2.	Aluminium Paint	Berger	Berger Aluminium
3.	Interior Emulsion	Asian Berger ICI	Royale Luxol Silk Supercote
4.	Exterior Emulsion	Asian ICI	ACE Supercote
5.	Distemper	Asian Berger ICI	Tractor Bison Maxilite
6.	Cement Paint	Snowcem Agsarcem	Snowcem Agsarcem
7.	A.C. Sheets	Everest India Ltd. Hyderabad India Ltd. Visaka Industries Ltd. Ramco	Everest I Charminar Visaka Ramco
8.	G.I. Pipes	TATA Zenith	TATA Zenith
9.	PVC Pipes	Avonplast Finolex Truebore Vignesh	Avonplast Finolex Truebore Vignesh

CIVIL ENGINEERING DEPARTMENT, BHEL, TRICHY-14
GENERAL CONDITIONS OF CONTRACT FOR LUMPSUM, ITEM RATES AND PERCENTAGE
CONTRACT

CONTENTS

Condition No	Description
CHAPTER - I	
1	DEFINITIONS
CHAPTER - II	
SCOPE OF CONTRACT	
2	HEADING TO THE CONTRACT
3	CONTRACT DOCUMENTS
4	WORKS TO BE CARRIED OUT
5	PROVISIONAL ITEMS
6	DEVIATIONS
7	TIME
8	STORES & MATERIALS
9	DELAY & EXTENSION OF TIME
10	PATENT RIGHTS
11	OCTROI AND OTHER DUTIES
12	ROYALTIES
13	PLANT & EQUIPMENT
14	ASSIGNMENT OR TRANSFER OF CONTRACT
	a) SUB-CONTRACT
15	COMPLIANCE TO REGULATIONS AND BYE-LAWS
CHAPTER - III	
PERFORMANCE OF THE CONTRACT	
16	SECURITY DEPOSIT
17	ORDERS UNDER THE CONTRACT
18	ADMISSION TO SITE
19	CONTRACTOR'S SUPERVISION
20	LABOUR
21	WATER
22	TEMPORARY WORKSHOPS, STORES ETC.
23	STORES & MATERIALS ON SITE
24	TOOLS AND PLANTS ON SITE

25	STATEMENT OF HIRE CHARGES
26	PRECAUTIONS AGAINST RISKS
27	NOTICE & FEES
28	SETTING OUT OF THE WORKS & PROTECTION & MAINTAINING SIGNALS AND WORKS
29	SITE DRAINAGE
30	EXCAVATIONS, RELICS ETC.
31	FOUNDATIONS
32	COVERING-IN WORKS
33	APPROVAL OF WORKS BY STAGES
34	EXECUTION OF WORKS
35	DAY WORKS
36	INSPECTION OF THE WORKS
37	RESPONSIBILITY FOR BUILDING
38	INSURANCE OF WORKS
39	DAMAGE AND LOSS TO PRIVATE PROPERTY & INJURY TO WOKMEN
40	COMPLETION
41	COMPENSATION FOR DELAY
42	LAWS GOVERNING THE CONTRACT
43	CANCELLATION OF CONTRACT FOR CORRUPT ACT
44	CANCELLATION OF CONTRACT FOR INSOLVENCY,ASSIGNMENT OR SUB LETTING OF CONTRACT
45	CANCELLATION OF CONTRACT FOR DEFAULT
46	TERMINATION OF CONTRACT FOR DEATH
47	SPECIAL POWERS OF DETERMINATION
48	FAIR WAGE

CHAPTER – IV

VALUATION AND PAYMENT

49	RECORDS & MEASUREMENTS
50	VALUATION OF DEVIATIONS
51	REIMBURSEMENT/ REFUND ON VARIATION IN PRICE
52	ADVANCES ON ACCOUNT

CIVIL ENGINEERING DEPARTMENT,BHEL,TRICHY-14

- 53 FINAL BILL
- 54 PAYMENT OF BILLS
- 55 RECOVERY FROM CONTRACTOR
- 56 POST TECHNICAL AUDIT OF WORKS AND BILLS
- 57 REFUND OF SECURITY DEPOSIT
- 58 ARBITRATION

ANNEXURE

BHEL CONTRACTOR'S LABOUR REGULATIONS

MODEL RULES FOR LABOUR LAWS

BHEL SAFETY CODE

1. DEFINITIONS

In these General Conditions of Contract, the following terms shall have the meaning hereby assigned to them except where the context otherwise requires:-

- a) The “CONTRACT” means the documents forming the tender and acceptance thereof, together with all documents referred to therein including General and Special Conditions of Contract, Schedules ‘A’, ‘B’, ‘C’, ‘D’, ‘E’, and / or General Summary attached to the form of tender, the Bharat Heavy Electricals Limited, Schedule of Rates as amended and in force the Specifications and the Drawings. All these documents as applicable taken together shall be deemed to form one Contract and shall be complementary to one another.
- b) The “TENDER DOCUMENTS” means the form of Tender the applicable Schedules ‘A’, ‘B’, ‘C’, ‘D’, ‘E’, and / or General Summary, General and Special Conditions of Contract and the Specification and / or Drawings as given to Contractors on payment for the purpose of preparing their tenders.
- c) The “WORK” means the work described in the tender documents in individual work orders and/or accompanying Drawings and Specifications as may be issued from time to time to the Contractor by the Engineer-in-charge within the powers conferred upon them, including all modified or additional works and obligations to be carried out either at the site or at any Factory Workshop or other place as required for the performance of the Contract.
- d) The “SITE” means the lands and/or other places on, in into or through which the work is to be executed under the Contract or any adjacent land, path or street which may be allotted to or used for the purpose of carrying out the contract.
- e) The “CONTRACTOR” means the individual, firm or Company, whether incorporated or not undertaking the work and shall include the legal personal representatives of such individuals or the persons composing the firm or Company, or the successors of the firm or Company and the permitted assigns of such individual or firm or Company.
- f) The “ Engineer-in-charge” means the Engineer who is incharge for the works referred.

CHAPTER II

SCOPE OF CONTRACT

2. Heading to the Contract:

The heading to these conditions shall not effect the interpretation thereof.

3. Contract Documents

The Accepting Officer shall furnish to the Contractor on demand “FREE OF COST” three copies of signed drawings and one copy of the signed agreement comprising of preamble to agreement, General and Special Specifications,

CIVIL ENGINEERING DEPARTMENT, BHEL, TRICHY-14

Schedule 'A', 'B', 'C', & 'E', etc., (but excluding General Conditions of Contract and Drawings) and **three** copies of all further drawings issued during the progress of work.

However, for any additional copies of the agreement or drawings required by the Contractor the same will be supplied on payment at the specified cost.

The Contractor shall keep one copy of all the Drawings and the Specifications at the site and the Engineer-in-charge or his representative shall have access to them at all reasonable times.

None of these documents shall be used by the contractor for any purpose other than that of this contract.

The Contractor shall take necessary steps to ensure that all persons employed on any work in connection with this contract have noticed that the Indian official Secrets Act 1923 (XIX of 1923) applies to them and shall continue so to apply even after the execution of such works under the contract.

4. Works to be Carried Out

The Contract shall, except as provided under Schedules 'B' and 'C' include all labour, materials, tools, plants equipment and transport which may be required in preparation for, and in the entire execution and full completion of the work. Schedule 'A' shall be deemed to have been prepared in accordance with good practice and recognized principles and unless otherwise stated, the descriptions given therein shall be held to include waste on materials carriage and cartage, lead, return of empties, hoisting, setting, fitting in position and all other labour necessary in and for the entire execution and full completion aforesaid. Any error in description or quantity in schedule 'A' or any omission there from shall not vitiate the Contract or release the Contractor from the execution of the whole or any part of the work comprised therein according to the Drawings and Specifications, or from any of his obligations under the Contract. The insertion of the name of any firm of suppliers in the Tender Documents is for the purpose of obtaining a particular class or quality of materials or workmanship but the articles or materials specified may be obtained from any other firm subject to prior written approval of the Engineer – in – charge.

In the case of a discrepancy between Schedule 'A' the specification and / or the Drawing, the Accepting Officer shall be the sole deciding authority as to which shall prevail and his decision shall be final and conclusive. If neither Drawings nor Specifications contain any mention of minor details of construction, which in the opinion of the Accepting Officer whose decision shall be final and conclusive, are reasonable and obviously and fairly intended for the satisfactory completion of the work, such details shall be provided by the Contractor without any extra cost as if they were specially mentioned and shall be deemed to be included in the contract.

The contractor will be deemed to have satisfied himself as to the nature of the site, local facilities of access and all matters affecting the execution and completion of the work. No extra charges consequent on any mis-understanding

in these respects or otherwise will be allowed.

5. Provisional Items

The full amount of provisional lumpsums and the value annexed to each provisional item inserted in the tender documents shall be deducted from the contract sum and the value of work ordered and executed thereunder shall be ascertained by measurement or valuation as for deviations.

No work under these items is to be begun without instructions in writing from the Engineer-in-charge.

The extent of quantities or items described as "Provisional" shall not be held to guarantee or limit the amount and description of the work to be executed by the contractor either in respect of the items concerned or the work as a whole.

No addition or deduction shall be made by the Contractor to the amount of the provisional lumpsums as included in the tender documents.

6. Deviations

The contractor shall not make any alteration in addition to or omission from the work as described in the tender documents except in pursuance of the written instructions of the Engineer-in-charge. No such deviation from the work described in the tender documents shall be valid unless the same has been specifically confirmed and accepted by the Accepting Officer in writing and incorporated in the contract.

The Accepting Officer may deviate either by way of addition or deduction, from the work so described, provided that the contract sum be not thereby varied on the whole by more than the percentage set out in the tender documents. The value of all addition and deductions will be added to, or deducted from the contract sum. Whenever the Accepting Officer intends to exercise such a right, his intention shall specify the deviations which are to be made, the lumpsum assessment or the proposed basis of payment, the extra time allowed, if any, and the date for completion of the entire contract.

Any objection by the Contractor to any matter concerning the order shall be notified by him in writing to the Engineer-in-charge within **Seven days** from the date of such order, but under no circumstances shall the work be stopped (unless so ordered by the Engineer-in-charge) owing to differences or controversy that may arise from such an objection. In the absence of such a notification of objection by the contractor, he will be deemed to have accepted the order and the conditions stated therein. In the event of the contractor failing to agree with the Engineer-in charge regarding the terms of the proposed deviation, the objection shall be referred to the Project Manager whose decision shall be final conclusive and binding on the Contractor.

7. Time

Time is the essence of the contract and is specified in the tender document or in each individual Work Order.

As soon as possible after the contract is let or any substantial Work Order is placed and before work under is to begin, the Engineer-in-charge and the

CIVIL ENGINEERING DEPARTMENT, BHEL, TRICHY-14

Contractor shall agree to a Time and Progress Chart. The Chart shall be prepared in direct relation to the time stated in the Tender Documents or the Work Order for the completion of the individual items there of and/the contract or order as a whole. It shall indicate the forecast of the dates for the commencement of the various trade processes or sequences of the work, and shall be amended as may be required by agreement between the Engineer-in-charge and the Contractor within the limitation of the time imposed in the Tender Documents or Order

In the absence of any specific Time and Progress chart to be agreed to between the Contractor and the Engineer-in-charge, the contractor shall ensure and maintain uninterrupted progress of the work such that the entire work shall be completed within the time imposed in the Tender Documents or Order and that the proportion of work completed upto any time in relation to the entire work to be under the Contractor Order shall not be less than the proportion that the time elapsed bears to the total time of completion provided in the Tender Documents or Order.

The contractor shall suspend the execution of the work, or any part or parts thereof whenever called upon in writing by the Engineer-in-charge to do so, and shall not resume work thereon until so directed in writing by the Engineer-in-charge. The Contractor will be allowed an extension of time for completion not less than the period of suspension. However, no other claim in this respect for compensation or otherwise however will be admitted. Provided the cause for suspension is not attributable to any default on the contractor's part to proceed with or fulfill the contractual obligations. This may also be extended to allow for alteration of work made by the deviation order.

8. Stores and Materials

The Contractor shall, at his own cost and expense, provide all materials required for the works, other than those listed in Schedule 'B', which are to be supplied by Bharat Heavy Electricals Limited. All materials to be supplied by the Contractor shall be of the best kind as described in the specifications and the Contractor shall, if requested by the Engineer-in-charge, furnish proof to the satisfaction of the Engineer-in-charge, that the materials so comply with the specifications.

The contractor shall, at his own expense and without delay, supply samples of materials proposed to be used in the execution of the work for approval of the Engineer-in-charge, who may reject the materials not corresponding either in quality or character to the approved samples.

In the case of stores provided under Schedule 'B' the Contractor shall bear the cost of loading, transporting to site, unloading, storing under cover as required assembling and jointing the several parts together as necessary and incorporating or fixing these stores materials in the work, including all preparatory work of whatever description as may be required, and of closing, preparing, loading and returning empty cases or containers to the place of issue without any extra charges.

9. Delay and Extension of Time:

CIVIL ENGINEERING DEPARTMENT, BHEL, TRICHY-14

if, in the opinion of Engineer-in-charge the work is delayed:

- i) by reason of abnormally bad weather, OR
- ii) by reason of serious loss or damage by fire, OR
- iii) by reason of Civil commotion, local combination of workmen strike or lockout, affecting any of the trades employed on the work OR.
- iv) by delay on the part of the agency or tradesman engaged by BHEL in executing work not forming part of this contract, OR
- v) by reason of any other cause which in the absolute discretion of the Engineer-in-charge is (when he is the Accepting Officer of the Contract) beyond the Contractor's reasonable control, than in such case the Accepting Officer on the recommendation of the Engineer-in-charge (or higher authority) may make fair and reasonable extension in the completion dates of the individual items of work or the contract as a whole. Such extension which will be communicated to the Contractor by the Engineer-in-charge in writing shall be final and binding on the Contractor. No other claim in this respect for compensation or otherwise howsoever is admissible. Upon the happening of any such event causing delay, the Contractor shall immediately given notice thereof in writing to the Engineer-in-charge but shall nevertheless use constantly his best endeavour to prevent or make good the delay and shall do all that may reasonably be required to the satisfaction of the Engineer-in-charge to proceed with the work.

10. Patent Rights:

The Contractor shall fully indemnify B.H.E.L or the agent, servant, or employee of B.H.E.L against any action, claim or proceeding relating to infringement or the use of any patent or design or any alleged patent or design rights, and shall pay any royalties which may be payable in respect of any article / or part there of included in the contract.

In the event of any claims being made or action brought against B.H.E.L or any agent, or servant or employee of BHEL in respect of matters aforesaid the Contractor shall immediately be notified thereof for taking necessary action provided that payment of indemnity shall not apply when such infringement has taken place in complying with the specific directions issued by the BHEL but the Contractor shall pay any royalties payable in respect of any such use.

11. Octroi and Other Duties:

All charges on account of Octroi, Terminal or Sales Tax and/or other duties on material obtained for the work (excluding materials provided by B.H.E.L on payment) shall be borne by the contractor.

12. Royalties:

Royalties fixed from time to time as per prevalent local rules will be recovered for materials, which the Contractor may be allowed to remove from quarries situated on land which is in charge of the B.H.E.L authorities.

13. Plant and Equipment:

CIVIL ENGINEERING DEPARTMENT, BHEL, TRICHY-14

The Contractor, shall at his own expense, supply all tools, plant and equipment (here-in-after referred to as T & P) required for the execution of the contract other than those listed in Schedule 'C' which subject to their availability may be hired by B.H.E.L., to the Contractor or issued free for use in the execution of the work as specified in Tender Documents.

14. Assignment or Transfer of Contract:

The Contractor shall not, without the prior written approval of the Accepting Officer, assign or transfer the Contract or any part thereof, or any share, or interest therein to any other person. No sum of money which may become payable under the Contract shall be payable to any person other than the Contractor unless the prior written approval of the Accepting Officer to the assignment or transfer of such money is given.

14. (a) Sub Contract:

The Contractor shall not sub-let any portion of the Contract without the prior written approval of the Accepting Officer.

15. Compliance to Regulations and Bye Laws:

The Contractor shall conform to the provision of any statute relating to the work and regulations and bye-laws of any local authority and of any water and lighting Companies or Undertakings with whose system the work is proposed to be connected. He shall, before making any variation from the drawings or the specifications that may be necessitated for such connections give the Engineer-in-charge notice, specifying the variation proposed to be made and the reasons

there for and shall not carry out any such variation until he has received instructions from the Engineer-in-charge in respect thereof. The contractor shall be bound to give all notice required by Statute Regulations or Bye-laws as aforesaid and to pay all fees, and taxes payable to any authority in respect thereof.

CHAPTER III

PERFORMANCE OF THE CONTRACT

16. Security Deposit

16.1 The Security Deposit shall be collected from the successful tenderer. The total amount of security deposit will be 5% of the contract value. EMD of the successful tenderer shall be converted and adjusted towards the required amount of Security Deposit.

At least 50% of the required Security Deposit, including the EMD has to be furnished by the contractor before commencement of the work.

Failing which the recovery of interest will be made at prime lending rate of SBI plus 2% for the period of default.

CIVIL ENGINEERING DEPARTMENT, BHEL, TRICHY-14

16.2 Security Deposit may be furnished in any one of the following forms:

- i. Cash (as permissible under the extant Income Tax Act)**
- ii. Local cheques of Scheduled Banks (subject to realization)/ Pay Order/ Demand Draft/ Electronic Fund Transfer in favour of BHEL**
- iii. Bank Guarantee from Scheduled Banks/ Public Financial Institutions as defined in the Companies Act. The Bank Guarantee format should have the approval of BHEL**
- iv. Fixed Deposit Receipt issued by Scheduled Banks/ Public Financial Institutions as defined in the Companies Act (FDR should be in the name of the Contractor, a/c BHEL)**
- v. Securities available from Indian Post offices such as National Savings Certificates, Kisan Vikas Patras etc. (held in the name of Contractor furnishing the security and duly endorsed/ hypothecated/ pledged, as applicable, in favour of BHEL, Trichy)**

(Note: BHEL will not be liable or responsible in any manner for the collection of interest or renewal of the documents or in any other matter connected therewith)

16.3 Security Deposit can also be recovered at the rate of 10% of the gross amount progressively from each of the running bills till the total amount of the required Security Deposit is collected. However in such cases at least 50% of the Security deposit should be collected before start of the work and the balance 50% may be recovered from the running bills.

(Note: In case of (a) small value contracts not exceeding Rs. 20 lakhs or (b) SAS jobs, work can be started before the required Security Deposit is collected. However, payment can be released only after collection/ recovery of initial 50% Security Deposit).

The Security Deposit shall not carry any interest

All compensation or other sums of money payable by the Contractor to BHEL, under the terms of this Contract or under any other contract with BHEL, may be deducted from the Security Deposit or realized by the sale of the Securities or from the interest arising there from or from any sums which may be due or may become due to the Contractor payable by BHEL, on any account whatsoever against this Contract or any other Contract with BHEL, and in the event of his Security Deposit being reduced by reason of such deductions or sale as aforesaid, the Contractor shall, within seven days thereafter, make good in cash or in securities endorsed as aforesaid, any sum or sums by which the Security Deposit has been so reduced.

50% of the Security Deposit / may be refunded on completion of the work after payment of the final bill and the balance 50% of the Security Deposit is refundable only after the expiry of the maintenance period of six (6) months from the date of completion of work as stipulated in the Contract concerned.

17. Order under the contract

All orders, notices etc., to be given under the contract shall be in writing typescript or printed and if sent by registered post to the address given in the tender of the contractor, shall be deemed to have been served on the date when in the ordinary course they would have been delivered to him.

The contractor shall carry out without delay all orders given to him.

18. Admission to site

The Contractor shall not enter on (other than for inspection purposes) or take possession of the site unless permitted to do so by the Engineer-in-charge. The portions of the Site to be occupied by the Contractor will be clearly defined and marked on the site plan, and the Contractor will on no account be allowed to extend his operations beyond these areas.

The Contractor shall provide, if necessary or required at the Site, temporary access there to and shall alter, modify and maintain the same as required from time to time. He shall take out and clear away the access route when no longer required and restoring the area to its original condition.

The Engineer-in-charge shall have power to execute other works (whether or not connected with the work in the contract agreement) on the site contemporaneously with the execution of the original work and Contractor shall give reasonable facilities for this purpose.

B.H.E.L reserves the right of taking over, at any time, any portion of the site which they may require and the Contractor shall at his own expense clear such portion forthwith. No photographs of the Site or of the work or any part there of shall be taken, published or otherwise circulated without the prior approval of the Engineer-in-charge.

No such approval shall however exempt the contractor from complying with any statutory provisions in regard to the taking and publication of such photographs.

B.H.E.L Officials connected with the Contract shall have the right of entry to the Site at all times.

Engineer - in charge shall have the power to exclude from the site any person whose admission there to may, in his opinion be undesirable for any reason whatsoever.

19. Contractor's Supervision

The Contractor shall either himself supervise the execution of the Contract or shall appoint a competent Agent approved by the Engineer-in-charge to act in his stead. The contractor shall employ an Engineer/Agent having at least a 'Degree of Bachelor of Civil Engineering' from a recognized University/on any work with a Contract value exceeding rupees two lakhs, and having at least a

CIVIL ENGINEERING DEPARTMENT, BHEL, TRICHY-14

Diploma in civil Engineering from a recognised college, on work with a contract value exceeding Rs. 50,000/- but not exceeding rupees two lakhs.

The Employment of an Engineer/Agent as aforesaid shall not be necessary if the Contractor himself in possession of a recognized technical qualification and is in opinion of the Engineer-in-charge capable of receiving instructions of the Engineer-in-charge and of executing the work to the satisfaction of the Engineer-in-charge. If the Contractor fails to appoint a suitable Engineer/ Agent as aforesaid, the Engineer-in-charge shall have full powers to suspend the execution of work and stop payment of any advances that may have become due until such date as a suitable Engineer/Agent is appointed and the contractor shall be held responsible for the delay caused to the work and no extension of time on this account shall be given to him as stipulated in condition (9) above.

Orders given to the Contractor's Agent/Engineer shall be considered to have the same force as if they had been given to the Contractor himself.

The contractor or his Agent shall be in attendance at the site during all working hours and shall superintend the execution of work with such additional assistance in each trade as the Engineer-in - charge may consider necessary.

The contractor or his accredited agent shall attend when required and without making any claim for doing so, either the Office of the Engineer-in-charge or the work site to receive instructions.

The Engineer-in-charge shall have full powers, and without assigning any reason to require the Contractor immediately to cease to employ in connection with the Contract any Agent, servant or employee whose continued employment is, in his opinion undesirable.

The Contractor shall not be allowed any compensation on this account.

LABOUR

20. The Contractor shall employ labourer in sufficient numbers either directly or through sub-contractors to maintain the required rate of progress and of quality to ensure workmanship of the degree specified in the Contract and to the satisfaction of the Engineer-in-charge. The Contractor shall not employ in connection with the works any person who has not completed his fifteen years of age.

The Contractor shall furnish to the Engineer-in-charge at the intervals specified by him, a distribution return of the number and description by trades of the work people employed on the works. The Contractor shall also submit on the 4th and 19th of every month to the Engineer-in-charge a true statement showing in respect of the second half of the preceding month and the 1st half of the current month (i) the accidents that occurred during the said fortnight showing the circumstances under which they happened and the extent of damage and injury caused by them and (ii) The number of female workers who have been allowed maternity benefit as provided in the Maternity Benefit Act, 1961 or Rules made thereunder and the amount paid to them.

The Contractor shall pay to labour employed by him either directly or through sub-contractors wages not less than fair wages as defined in the Contractor's Labour Regulations.

The contractor shall in respect of labour employed by him either directly or through sub-contractors comply with or cause to be complied with Contractor's Labour Regulations in regard to all matters provided therein.

The Contractor shall comply with the provisions of the Payment of Wages Act 1936, Minimum Wages Act 1948, Employers liability Act 1938, Workmen's Compensation Act 1923, Industrial Disputes Act 1947, Maternity Benefit Act 1961 and Mines Act 1952, Contract Labour Regulation and Abolition Act 1970 or any modifications there of or any other law relating thereto and rules made thereunder from time to time.

The contractor shall be liable to pay his contribution and the employees' contribution to the State Insurance Scheme in respect of all labour employed by him for the execution of the contract, in accordance with the provision of "The Employees' State Insurance Act, 1948" as amended from time to time. In case the contractor fails to submit full details of his account of labour employed and the contribution payable, the Engineer-in-charge shall recover from the running bills of contractor an amount of contribution as assessed by him. The amount so recovered shall be adjusted against the actual contribution payable for Employees' State Insurance.

The Engineer-in-charge shall on a report having been made by an Inspecting Officer as defined in the Contractor's labour Regulations have the power to deduct from the moneys due to the Contractor any sum required or estimated to be required for making good the loss suffered by the worker or worker by reason of non-fulfillment of the Conditions of the Contract for the benefit of workers, non-payment of wages or of deductions made from his or their wages which are not justified by the terms of the Contract or non-observance of the said Contractor's Labour Regulations.

The Contractor shall indemnify the B.H.E.L against any payments to be made under and for observance of the Regulations aforesaid without prejudice to his right to claim indemnity from his sub-contractors.

In the event of the Contractor committing a default or breach of any of the provisions of the aforesaid Contractor's Labour Regulations, as amended from time to time or furnishing any information or submitting or filling any form / Register/Slip under the provisions of these Regulations which is materially incorrect then on the report of the Inspecting Officers as defined in the Contractor's Labour Regulation, the Contractor shall without prejudice to any other liability pay to the B.H.E.L a sum not exceeding Rs. 50/- as liquidated damages for every default breach or furnishing, making submitting, filling materially incorrect statement as may be fixed by the Engineer-in-charge and in the event of the Contractor's default continuing in this respect, the liquidated damages may be enhanced to Rs. 50/- per day for each day of default subject to a maximum percent of the estimated cost of works put to tender.

The Engineer in charge shall deduct such amount from bills or security deposit of the Contractor and credit the same to the Welfare Fund constituted under Regulations. The decision of the Engineer-in-charge in this respect shall be final and binding.

Model Rules for Labour Welfare

The Contractor shall at his own expense comply with or cause to be complied with Model Rules for Labour welfare as appended to these Conditions or rules framed by Government from time to time for the protection of health and for making sanitary arrangements for workers employed directly/or indirectly on the works. In case the Contractor fails to make arrangements as aforesaid, the Engineer-in-charge shall be entitled to do so and recover the cost thereof from the Contractor.

Safety Code

The Contractor shall at his own expense arrange for the safety provisions as appended to these conditions or as required by the Engineer – in – charge, in respect of all labour directly or indirectly employed for performance of the works and shall provide all facilities in connection therewith. In case the Contractor fails to make arrangements and provide necessary facilities as aforesaid, the Engineer– in– charge shall be entitled to do so and recover the cost thereof from the Contractor.

Failure to comply with model Rules for Labour Welfare, Safety Code, or the provisions relating to report on accidents and to grant of maternity benefits to female workers shall make the Contractor liable to pay to the B.H.E.L as liquidated damages an amount not exceeding Rs. 50/- for each default or materially incorrect statement. The decision of the Engineer-in-charge in such matters based on reports from the Inspecting Officers as defined in the Contractor's Labour Regulation as appended to these conditions shall be final and binding and deductions for recovery of such liquidated damages may be made from any amount payable to the Contractor.

WATER

21. The Contractor shall allow in his Tender and provide at his cost all water required for the work or his employees on the work, together with all pipes and fittings or other means that may be necessary or required to ensure a proper and ample supply of water for all purposes connected with the work.

Water will be supplied from the BHEL supply system, or other sources at one point fixed by the Engineer-in-charge on the site of work at free of cost. The Contractor shall make necessary arrangement for lifting pumping, carrying or conveying the water as required at his own cost.

22. Temporary Workshops, Stores Etc.

The Contractor shall, during the progress of the work provide, erect and maintain at his own expense all necessary temporary workshops, stores, offices, etc., required for the proper and efficient execution of the work. The planning, siting and erection of these buildings shall have the approval of the Engineer-in-charge and the Contractor shall at all times keep them tidy and in a clean and sanitary condition to the entire satisfaction of the Engineer-in-charge.

CIVIL ENGINEERING DEPARTMENT, BHEL, TRICHY-14

On completion of the work all such temporary buildings shall be cleared away and the site restored and left in a clean and tidy condition to the entire satisfaction of the Engineer-in-charge.

23. Stores and Materials on Site

All stores and materials required for the work are to be deposited by the Contractor only in places to be indicated by the Engineer-in-charge.

Where in accordance with the contract stipulations certain Stores & Materials (for incorporation in the work) are to be issued to the Contractor by the BHEL as detailed under Schedule 'B' **such items will be so issued only to the extent required for the actual completion of the work** as stipulated in the contract. The decision of the Engineer-in-charge regarding the quantities to be issued as above shall be final and binding on the contractor. For any excess quantities consumed on the work upto 5% over the theoretical consumption will be charged at issue rates and excess consumption beyond this limit, their cost will be recovered from the Contractor at punitive rates which will be 100% (Hundred Percent) more than the issue rates of the BHEL as specified in the Instructions to the Tenderers.

In regard to the materials and stores which may be issued to the Contractor by BHEL the Contractor shall give the Engineer-in-charge reasonable notice in writing of his requirements of such stores and materials and on the approval of his demand being notified to him, he shall make immediate arrangements for drawing the same. Such stores and materials shall be transported by the Contractor at his own expense direct from the place of issue to the site of the work, unless prior written approval is obtained from the Engineer-in-charge to take them to a Store or Workshop elsewhere.

The Contractor shall have to build a weather proof shed for the storage of cement required for 15 days consumption of the work.

BHEL Officers connected with the Contract shall have the power at any time to inspect and examine any stores or materials intended to be used in or on the work, whether on the site or at any factory or workshop or other place where such stores or materials are being fabricated or manufactured or at any place where the same are lying and the contractor shall give necessary facilities for such inspection and examination.

The Engineer-in-charge shall be entitled to have tests made of any stores or materials supplied by the Contractor who shall provide at his own expense all facilities which the Engineer-in-charge may require for this purpose. If at the discretion of the Engineer-in-charge an independent expert is employed to make any such tests his charges shall be borne by the Contractor only if the test discloses that the said stores or materials are not in accordance with the provisions of the Contract.

Should the Engineer-in-charge consider at any time during the construction or re-construction, on prior to the expiry of the "MAINTENANCE PERIOD" that the stores or materials provided by the Contractor are unsound or of a quality inferior to that contracted for or otherwise not in accordance with the contract (in respect whereof the decision of the Engineer-in-charge shall be final and conclusive) the Contractor, shall on demand, in writing from the Engineer-in-charge specifying the Stores or materials complained of, notwithstanding that the same may have been

CIVIL ENGINEERING DEPARTMENT, BHEL, TRICHY-14

inadvertently passed, certified and paid for, forthwith remove the stores or materials so specified and provide other proper and suitable stores or materials at his own expense; to the entire satisfaction of the Engineer-in-charge and in the event of his failing to do so within a period to be specified by the Engineer-in-charge in his demand aforesaid the Engineer-in-charge may replace within others the stores or materials complained of at the risk and expense in all respects of the Contractor. The liability of the contractor under this condition shall not extend beyond the maintenance period aforesaid except as regards stores or materials which the Engineer-in-charge shall have previously given notice to the contractor to replace. (*MAINTENANCE PERIOD for any work under this Organisation will be SIX MONTHS FROM THE DATE OF ACTUAL COMPLETION of the particular work and handing over to B.H.E.L).

All stores and materials brought to the Site shall become and remain the property of B.H.E.L and shall not be removed from the site without prior written approval of the Engineer-in-charge. However, when the work is finally completed, the Contractor shall at his own expense forthwith remove from the site all surplus stores or materials originally supplied by him and upon such removal, the same shall revert in and become the property of Contractor. All B.H.E.L Stores and materials issued to Contractor for in-corporation or fixing in the work and which, making due allowance for reasonable wear and tear/or waste, have not on completion of the work been so incorporated or fixed, shall be returned by the Contractor at his own expense to the place of issue.

Credit for surplus stores and/ or materials returned by the contractor to B.H.E.L will be given to him at a price based on the prevailing market rate but not exceeding that at which the said stores and materials were originally issued to him but due consideration shall be given to the allowance claimed by B.H.E.L in respect or any depreciation or damage suffered by the stores and/or materials whilst in the custody of the Contractor regarding which the decision of Engineer-in-charge shall be final and conclusive.

If, in the opinion of the Engineer-in-charge (which shall be final and conclusive) any stores, supplied by B.H.E.L have either during currency of the work or after completion of the work whilst under the custody of the Contractor, become damaged to such an extent that they cannot be usefully utilized, either in the same work or in other works, the Engineer-in-charge shall not accept the stores and in the event of his rejection the contractor shall be charged for the said Stores at a rate as fixed by the Accepting Officer. The Contractor shall not be entitled to any claim whatsoever on this account.

24 Tools and Plants on site:

All tools, plants and equipment brought to the site shall become the property of B.H.E.L and shall not be removed from the site without the prior written approval of the Engineer-in-charge when the work is finally completed or the Contract is determined for reasons other than the default of the Contractor he shall forthwith remove from the site all tools, plants, equipments etc., (other than those as may have been provided by B.H.E.L) and upon such removal, the same shall in, and become the property of the Contractor.

25. Statement of Hire Charges:

A monthly detailed statement of the hire charge incurred in respect of B.H.E.L tools, plants, equipments etc., shall be given to the Contractor by the Engineer-in-charge.

26. Precaution Against risks:

The Contractor shall be responsible for providing at his own expense, for all precautions to prevent loss or damage from any and all risks and to minimize the amount of any such loss or damage and for the necessary steps to be taken for the said purpose until the works have been handed over complete in all respect of the Engineer-in-charge.

The Contractor shall provide all watchmen necessary for the protection of the site, the work, the materials, tools, plants, equipments and anything else lying on the Site during the progress of the work. He shall be solely responsible for and shall take all reasonable and proper steps for protecting, securing, lighting and watching, all places on or about the work and the Site which may be dangerous to any person whomsoever.

27. Notices and Fees:

The Contractor shall give all notices required by any Statutory provision or by the regulations and/or bylaws of any local Authority and/or of any Public Service, Company or Authority affected by the work or with whose system the same are or will be connected. The Contractor shall pay and indemnify B.H.E.L against any fees and charges payable under such Acts. Regulation and/or byelaws in respect of the work and shall make and supply all drawings and plans required in connection with any such notice.

28. Setting out of the Works and Protective and Maintaining Signals and Works:

The Engineer-in-charge shall supply dimensioned drawings, levels and other information necessary to enable the contractor to set out the work. The Contractor shall at his own expense set accurately according to the drawings and figured dimension thereon, all the work comprised in the contract and any extras or additions thereto and shall be solely responsible for their being so set out and executed. All bench marks, pegs, signals on the surface, alignment stones, milestones and all similar marks whether put in by B.H.E.L Authorities for the purpose of checking the Contractor's work or in the nature of permanent survey marks will during the tenure of the contract, be under the care of the Contractor who shall, at his own expense, take all proper and reasonable precautions and care to preserve and maintain them in their true position. In the event of these marks being disturbed or obliterated by accident or due to any other cause whatsoever, the same may, if deemed necessary, be replaced by the Engineer-in-charge at the Contractor's expense and the cost thereof deducted from any money then or thereafter becoming due to the Contractor.

Where requested by the Contractor, the level marks, center line and chainage pegs corresponding to those shown on the Drawing will be pointed out to the

CIVIL ENGINEERING DEPARTMENT, BHEL, TRICHY-14

Contractor on the ground but all bench marks or chainage pegs additional to those shown on the Drawing will be set out by BHEL authorities.

29. Site Drainage:

All water that may accumulate on the site during the progress of the work or in trenches and excavations shall be removed to the entire satisfaction of the Engineer-in-charge and at Contractor's expense.

30. Excavations, Relics Etc.

Material of any kind obtained from excavation on the site shall remain the property of BHEL and shall be disposed off as Engineer-in-Charge directs.

All gold, silver, oil and other minerals of any description and all precious stones, coins, treasures, relics, antiques and other similar items which may be found in or upon the site shall be the property of Bharat Heavy Electricals Limited and the Contractor shall duly preserve the same to the satisfaction of the BHEL and shall from time to time deliver the same to such person or persons as the B.H.E.L may appoint to receive the same.

31. Foundations

The Contractor shall not lay any foundations until the excavations for the same have been examined and approved in writing by the Engineer-in-charge.

32. Covering-in Work

The Contractor shall give reasonable notice in writing to the Engineer-in-charge whenever any work is to be permanently covered up or concealed, whether by earth or other means so that it can finally be inspected or measured if necessary. In default of so doing, the Contractor shall, if required by the Engineer-in-charge uncover such work at his own expense.

33. Approval of works by Stages:

All work embracing more than one process shall be subject to examination and approval at each stage thereof and the Contractor shall give due notice in writing to the Engineer-in-charge when each stage is ready. In default of such notice being received, the Engineer-in-charge shall be entitled to approve the quality and extent thereof at any time he may choose and in the event of any dispute, the decision of the Engineer-in-charge thereon shall be final and conclusive.

34. Execution of the Work:

The work shall be executed in a workman-like manner and to the satisfaction in all respects of the Engineer-in-charge.

The Engineer-in-charge will communicate or confirm his instructions to the Contractor in respect of the execution of the Work in a "Work Site Order Book" maintained at his office and the Contractor shall visit this office daily and shall confirm receipt of such instructions by signing the relevant entries in this book. Such entries will rank as order or notices in writing within the intent and meaning of these conditions.

35. Day Work:

No day-work shall be performed without the prior written instructions of the Accepting Officer.

The Contractor shall give to the Engineer-in-charge reasonable notice of the start of any work ordered to be executed by day-work and shall deliver to the Engineer-in-charge within two days of the end of each pay week a return in duplicate giving full detailed accounts of labour and materials for that pay-week. One copy of each of these returns, if found correct, will be certified by the Engineer-in-charge and returned to the contractor and must be produced at the time of adjustment of accounts.

An invoice in duplicate signed by the Contractor or his agent shall be sent with each delivery of materials for day-work and the Contractor will be furnished with a receipt signed by the Engineer-in-charge specifying the description, quantities weight or measurement (as the case may be) of the articles approved, reference will be made in this receipt in the return aforesaid and the Contractor's Bill.

In the case of Lumpsum Contracts, the rates to be charged and the percentage addition for profit and establishment charges, etc., will be agreed upon between the Accepting Officer and the Contractor prior to the execution of the work.

36. Inspection of the Work:

B.H.E.L Officers concerned with the Contract shall have power at any time to inspect and examine any part of the work and the Contractor shall give such facilities as may be required to be given for such inspection and examination Should Engineer-in-charge consider, at any time during the expiry of the

maintenance period, that any work has been executed with unsound, imperfect or unskilled workmanship or of a quality inferior to that contracted for or not otherwise in accordance with the contract (in respect) whereof the decision of the Engineer-in-charge shall be final and conclusive the Contractor shall on demand in writing from the Engineer-in-charge specifying the fault notwithstanding that the same may have been inadvertently passed, certified and paid for, forthwith rectify or remove and reconstruct the work so specified in whole or in part as the case may be required at his own expense to the entire satisfaction of the Engineer-in-charge and in the event of his failing to do so within a period to be specified by the Engineer-in-charge in his demand as aforesaid, the Engineer-in-charge may carry out the work by other means at the risk and expense in all respects of the Contractor. However, the liability of the Contractor under this condition shall not extend beyond the maintenance period except as regards workmanship which the Engineer-in-charge shall have previously given notice to the Contractor to rectify.

37. Responsibility for Building:

In the event of any building or part of any building being handed over to the Contractor for the execution of work thereto under the provisions of the Contract, he shall give a written receipt for all fixtures, glass etc. and he shall be required to make good at his own expense all damages resulting from any cause whatsoever while in his charge and on completion of the work to deliver the said building or part thereof in a clean state complete in every particular to the entire satisfaction of the Engineer-in-charge.

38. Insurance

The contractor shall within one month after the date of the acceptance of the contract, insure the work against loss or damage to the contract works, temporary work and materials erected in performance of the contract on "all risks" basis from the time of arrival on site until taken over by BHEL on completion of the contract.

The cover shall also include wherever necessary the risks of testing including breakdown or explosion of plant and machinery undergoing testing, trial and commissioning operations. The insurance shall also specifically cover removal of debris cost. The sum insured shall represent the estimated full value of the contract works inclusive of value of free supply materials by BHEL, transport charges, customs dues, express freight, overtime charges, cost of erection, value of constructional plants and machinery, removal of debris and escalation of costs where the contract includes a maintenance period, the insurance cover shall specifically include the contractors' liabilities during the maintenance period. The insurance shall also be extended to cover third party personal injury and property damage for a sum to be specified by BHEL. The insurance shall be effected in the name of BHEL and the contractor shall submit to BHEL a draft of the insurance policy for approval. The policy when issued will be lodged with BHEL together with receipts of premium for such insurance and the contractor shall maintain such policies in force until the obligations of the contractor are fully discharged.

If the contractor fails to comply with the terms of this condition the Accepting officer may insure the work and may deduct the amount of premiums from any money that may become payable to the contractor or may at his discretion refuse payment of any advances to the contractor until the contractor shall have complied with the terms of this condition. This provision does not, however, absolve the contractor of his responsibility for taking up the insurance. The contractor is, therefore, primarily responsible for taking up the insurance in time.

39. Damage and loss to private property and injury to workmen

The contractor shall at his own expense reinstate and make good to the satisfaction of the Engineer-in-charge and pay compensation for any injury, loss or damage occasioned to any property or rights whatever including property and rights of **B.H.E.L.**, (or agents, servants or employees of **B.H.E.L.**) the injury loss or damage arising out of or in anyway in connection with the execution or purported execution of the contract and further the contractor shall indemnify **B.H.E.L.**, against all claims enforceable against **B.H.E.L.**, or any agent, servant, or employee of **B.H.E.L.** a private person, in respect of any such injury (including injury resulting in death loss or damage to any person) whosoever or property, including all claims which may arise under the workmen's Compensation Act or otherwise, or which would be enforceable against **B.H.E.L.**

40. Completion

The works shall be completed to the entire satisfaction of the Engineer-in-charge and in accordance with the Contractor's forecast of Time and Progress where operative, and all unused stores and materials, tools, plants, equipments, temporary buildings and things shall be removed and the site and work cleared of rubbish

CIVIL ENGINEERING DEPARTMENT, BHEL, TRICHY-14

and all waste materials and delivered up clean and tidy to the satisfaction of the Engineer-in-charge at the Contractor's expense and/or before the Scheduled date of completion.

The B.H.E.L shall have power to take over from the Contractor from time to time each sections of the work as have been completed to the satisfaction of the Engineer-in-charge.

In case the Contractor fails to remove any of his properties, assets or fails to clear the rubbish and waste materials within 30 days of the completion of the contract, it is lawful for the contractee, that is BHEL to take such action as it deems fit to clear dispose of such properties, assets or such waste materials and charge the contractor any expenses incurred thereon.

The Engineer-in-charge shall certify to the Contractor the date on which the work is completed and the state thereof.

The Engineer-in-charge shall also certify to the Contractor the state of the work at the end of maintenance period, where applicable.

41. Compensation for Delay:

If the contractor fails to maintain the required progress in terms of condition 7 or to complete the work and clear the site on or before the contracted or extended period of completion, he shall, without prejudice to any other right or remedy of the B.H.E.L on account of such breach, pay as agreed compensation an amount calculated as stipulated below or such smaller amount as may be fixed by the BHEL on the contract value of the work for every week that the progress remains below that specified in condition 7 or that the work remains incomplete.

This will also apply to items or group of items for which separate period of completion has been specified.

For this purpose the term 'Contract Value' shall be the value at contract rates of the work as ordered.

a. Completion period (as originally-stipulated) -- at 1 percent per week.
Not exceeding 6 months.

b. Completion period (as originally-stipulated) -- at ½ percent per week
Exceeding 6 months and not exceeding 2 years.

c. Completion period (as originally-stipulated) -- at ¼ percent per week
Exceeding 2 years.

Provided always that the total amount of compensation for delay to be paid under this condition shall not exceed the under noted percentage of the contract value or of the contract value of the item or group of items of work for which a separate period of completion is given:

CIVIL ENGINEERING DEPARTMENT, BHEL, TRICHY-14

- a. Completion period (as originally-stipulated) -- 10 percent.
Not exceeding 6 months.
- b. Completion period (as originally-stipulated) -- 7½ percent.
Exceeding 6 months and not exceeding 2 years.
- c. Completion period (as original-stipulated) -- 5 percent.
Exceeding 2 years

The amount of compensation may be adjusted or set-off against any sum payable to the Contractor under this or any other contract with the B.H.E.L.

42. Laws Governing the Contract:

This contract shall be governed by the Indian Laws for the time being in force.

43. Cancellation of Contract for Corrupt Acts:

The Accepting Officer, whose decision shall be final and conclusive, shall, without prejudice to any other right or remedy which shall have accrued or shall accrue thereafter to Bharat Heavy Electricals Limited, cancel the contract in any of the following cases and the Contractor shall be liable to make payment to B.H.E.L for any loss or damage resulting from any such cancellation for default.

If the Contractor shall:

- a. Offer or give or agree to give to any person in BHEL service any gift or consideration of any kind as an inducement or reward for doing or for bearing to do or for having done or forborne to do a day act in relation to the obtaining or execution of this or any other contract for BHEL service **OR**
- b. Enter into a contract with B.H.E.L in connection with which commission has been paid or agreed to be paid by him or with his knowledge, unless the particulars of any such commission and the terms of payment thereof have previously been disclosed in writing to the Accepting Officer, **OR**
- c. Obtain a contract with B.H.E.L as a result of ring tendering or by non-bonafide methods of competitive tendering without first disclosing the fact in writing to the Accepting Officer.

44. Cancellation of Contract for Insolvency, Assignment or Transfer or Sub-Letting of Contract:

The Accepting Officer, without prejudice to any other right or remedy which shall accrue thereafter to B.H.E.L shall cancel the contract in any of the following cases:
If the Contractor,

- a) Being an individual, or if a firm any partner thereof shall at any time be adjudged bankrupt or have a receiving order or orders for administration of his Estate made against him or shall take any proceedings, for liquidation or composition under any Bankruptcy Act for the time being in force or make any conveyance or assignment of his effects of composition or arrangement for the benefit of his creditor or purport to do so, or if any application be made under any Bankruptcy Act for the time being in force for the sequestration of his Estate or if a trust deed be granted by him on behalf of his creditors, **OR**

CIVIL ENGINEERING DEPARTMENT, BHEL, TRICHY-14

- b) Being a Company, shall pass a resolution or the Court shall make an order for the liquidation of its affairs, or a Receiver or Manager on behalf of the debentures holders shall be appointed or circumstances shall arise which entitle the court or debentures holders to appoint a Receiver or Manager **OR**.
- c) Assigns, transfers, sub-lets or attempts to assign, transfer or sub-let any portion of the work without the prior written approval of the Accepting Officer. **OR**
- d) Shall suffer an execution being levied on his goods and allow it to be continued for a period of 21 days.

Whenever the Accepting Officer exercises his authority to cancel the Contract under this condition, he may complete the work by any means at the Contractor's risk and expense provided always that in the event of cost of the completion (as certified by Engineer-in-charge which is final and conclusive) being less than the contract cost, the advantage shall accrue to the BHEL and that if the cost of completion exceeds the money due to the Contractor under the contract, the Contractor shall either pay the excess amount ordered by the Engineer-in-charge or the same shall be recovered from the Contractor by other means.

Engineer-in-charge will have powers to take possessions of the site and any materials, constructional plant, implements, stores, etc, thereon and or carryout the work by any means at the risk and cost of the contractor.

In case the BHEL completes the work under the provisions of this condition the cost of such completion to be taken into account in determining the excess cost to be charged to the contractor under this Condition shall consist of the cost of materials purchased and/or labour provided by the BHEL with an addition of such percentage to cover superintendence and establishment charges as may be decided by the Project Manager/Project Engineer whose decision shall be final and conclusive.

If the contractor fails to pay the excess sum within a period of 30 days, the Engineer-in-charge shall have the right to sell any or all of the contractor's unused materials, constructional plant implements, temporary buildings, etc., and apply the proceeds of sale thereof towards the satisfaction of any sum due from the contractor under the contract and if thereafter be any balance outstanding from the contractor, it shall be recovered in accordance with the provisions of the contract.

45. Cancellation of contract in part or in full for contractor's default:

If the Contractor:

- (a) makes default in commencing the work within a reasonable time from the date of handing over of the site and continue in that state after a reasonable notice from Engineer-in-charge, **OR**

CIVIL ENGINEERING DEPARTMENT, BHEL, TRICHY-14

- (b) in the opinion of the Engineer-in-charge at any time, whether before or after the date or extended date for completion, makes default in proceeding with the work, with due diligence and continue in that state after a notice of seven days from Engineer-in-charge, OR
- (c) fails to comply with any of the terms and conditions of the contract or after 7 days notice in writing with orders properly issued there under, (OR)
- (d) fails to complete the work order and items of work individual dates for completion and clear the site on or before the date of completion or fails to achieve the progress as set out under clauses 7 of these General Conditions of Contract.

The Accepting Officer may, without prejudice to any other right or remedy which shall have accrued or shall accrue there after to B.H.E.L cancel the contract as a whole or in part thereof or only such work order or items of work in default from the contract. Whenever the Accepting Officer exercises his authority to cancel the contract as a whole or in part under this conditions he may complete the work at the Contractor's risk and cost, provided always that in the event of the cost of completion (as certified by Engineer-in-charge which is final and conclusive) being less than the contract cost the advantage shall accrue to the B.H.E.L if the cost of completion exceeds, the money due to the contractor under this contract, the contractor shall either pay the excess amount ordered by Project Manager or the same shall be recovered from the contractor by other means. Engineer-in-charge will have power to take possession of the site and any materials, constructional plant, implements, Stores, etc., thereon.

In case the B.H.E.L completes the work or any part thereof under the provisions of this conditions the cost of such completion to be taken in to account in determining the excess cost to be charged to the contractor under this conditions shall consists of the cost of materials purchased and/or labour provided by the B.H.E.L with an addition of such percentage to cover superintendence and establishment charges as may be decided by the Project Manager/Engineer whose decision shall be final and conclusive.

If the contractor fails to pay the excess sum within a period of 30 days, the Engineer-in-charge shall have the right to sell any or all of the contractor's unused materials, constructional plant implements, temporary buildings, etc, and apply the proceeds of sale thereof towards the satisfaction of any sum due from the contractor under the contract and if thereafter be any balance outstanding from the contractor it shall be recovered in accordance with the provision of the contract.

46. Termination of Contract for Death

Without prejudice to any of the rights or remedies under this contract if the contractor dies, the accepting Officer shall have the opinion of terminating the contract without compensation to the contractor.

47. Special Powers of Determination

If at any time after the acceptance of the tender B.H.E.L shall for any reason whatsoever not require the whole or any part of the work, to be carried out the project

CIVIL ENGINEERING DEPARTMENT,BHEL,TRICHY-14

Manager/Engineer shall give notice in writing of the fact to the Contractor who shall have no claim to any payment of compensation or otherwise howsoever on account of any profit or advantage which he might have derived from the execution of the work in full but which he did not derive in consequence of the foreclosing of the work.

He shall be paid at Contract rates, for the full amount of the work executed including such additional works, e.g. clearing of site, etc., as may be rendered necessary by the said fore closing. He shall also be allowed a reasonable payment (as decided by the Accepting Officer) for any expenses sustained on account of labour and materials collected but which could not be utilised on the work, as verified by the Engineer-in-charge. Neither shall the Contractor have any claim for compensation on account of any alterations having been made in the original specifications, drawings, designs and instructions, involving any curtailment of the work as originally contemplated.

48. Fair Wage

- a) The contractor shall pay not less than the “ Fair Wage” to labourers engaged by him on the work.

“Fair Wage” means wage whether for time or piece work notified at the time of inviting tenders for the work and where such wages have not been notified the wages prescribed by the Project Manager/Engineer for the stations at which the work is done.

- b) The Contractor shall not with standing the provision of any contract to the contrary, cause to be paid a “Fair Wage” to labourers indirectly engaged on the work, including any labour engaged by the Sub-Contractors in connection with the said work, as if the labourers had been directly employed by him.
- c) In respect of labourers directly or indirectly employed on the work for the performance of the Contractors part of this Agreement, the Contractor shall comply with or cause to be complied with B.H.E.L Contractor’s Labour Regulations (appended here to as Annexure ‘A’ to these conditions) in regard to payment of wages, wage period deduction from wages, recovery of wages not paid and deductions unauthorisedly made, maintenance of wage book, wage-slips publication of scale of wage and other terms of employment inspection and submission of periodical returns and all other matters of alike nature.
- d) The Engineer-in-charge concerned shall have the right to deduct from the money due to the contractor any sum required or estimated to be required for making good the loss suffered by a worker or workers by reason of non-fulfilment of the conditions of the contract for the benefit of the workers non-payment of wages or of deductions made from his or their wages which are not justified by the terms of the contract or non-observance of the regulations.
- e) The Contractor shall be liable primarily for all payments to be made under the contract and for the observance of the Regulations aforesaid

CIVIL ENGINEERING DEPARTMENT, BHEL, TRICHY-14

without prejudice to his right to claim indemnity from his sub-contractors.

- d) The regulations aforesaid shall be deemed to be a part of this contract and any breach thereof shall be deemed to be a breach of this Contract.

CHAPTER IV

VALUATION AND PAYMENT

49. Records and Measurements:

All items having a financial value shall be entered in the B.H.E.L Measurement Book so that a complete record is obtained of all works performed under the Contract.

Buildings, etc., priced in Schedule 'A' as a unit lumpsum will be entered by number at the unit lumpsum.

Work carried out for agreed lumpsum will be described and similarly recorded.

Lumpsum omissions will be entered for deduction. Measurement shall be restricted to that required to ascertain the financial liability of B.H.E.L under the contract.

Work which fails to be measured in detail shall be measured physically, without reference to any local custom that may obtain excepting where it may otherwise be directed in the tender documents. The measurements shall be taken jointly by any person duly authorized on the part of the BHEL and by the Contractor.

The Engineer-in-charge shall give reasonable notice in writing to the Contractor of appointment for measurement.

The Contractor shall, without extra charge, provide assistance with appliance and other things necessary for measurement.

The Contractor shall bear all the cost of measurement of his work.

Measurement shall be entered in the B.H.E.L Measurement Book and signed and dated by both parties each day at the Site on completion of measurement. If the Contractor objects to any of the measurements recorded on behalf of the B.H.E.L a note to that effect will be made in the BHEL Measurement Book or against the item or items objected to; and such note shall be signed and dated by both the parties engaged in taking the measurement.

If, as a result of such objection, it becomes necessary to re-measure the work wholly or in part, the expense of such re-measurement shall be borne by the party requiring the measurement.

Measurement to be re-taken, provided that a net error is found by this remeasurement to amount to less than 5% (five percent) of the value as recorded by the first measurement. But, where the net errors amount to 5% and over of the said

CIVIL ENGINEERING DEPARTMENT, BHEL, TRICHY-14

value, then the cost is to be borne by the other party. In any case, if the net value of errors found exceeds Rs. 500/- the expense of re-measurement is to be borne by the other party. If the Contractor's representative fails to attend when required, the Engineer-in-charge shall have power to proceed by himself to take measurement and in that case these measurements shall be accepted by the Contractor as final.

The contractor shall, once every month, submit to the Engineer-in-charge with a copy to the Civil Manager/Senior Engineer details of his claims for the work done by him up to and including the previous month which are not covered by his Contract Agreement in any of the following respects;

- a. Deviation from the items and Specifications provided in the contract documents.
- b. Extra Items/New Items of work
- c. Quantities in excess of those provided in the contract schedule.
- d. Items in respect of which rates have not been settled. He should, in addition furnish a clear certificate to the effect that the claims submitted by him as aforesaid cover all his claim and that no further claims shall be raised by him in respect of the work done up to and including the period under report.

Except where any general or detailed description of the work in quantities expressly shows to the contrary, schedule of quantities shall be deemed to have been prepared and measurements shall be taken in accordance with

the procedure set forth in the schedule of rates specification notwithstanding any provision in the relevant standard method of measurement or any general or local custom. In the case of items which are not covered by the schedule of rates / specification, measurements shall be taken in accordance with relevant standard method of measurement issued by the Indian Standard Institution or as per standard engineering practice.

50. Valuation of Deviations:

Rates for deviated items of work will be fixed as follows:-

1. For any item of work required to be carried out after the contract has been awarded and which is not covered by Contractor's Schedule but is covered by B.H.E.L Schedule of rates the rate payable for such a fresh item will be derived from B.H.E.L Schedule by the method of proportion as follows:
 - a. In the same proportion to rate in B.H.E.L Schedule of Rates as the tendered rate for the nearest analogous item of work in Contractor's schedule bears to rate for the particular analogous item of work in B.H.E.L Schedule of rates.
 - b. If a single appropriate analogous item of work is not available in both Schedule (Contractor's and B.H.E.L Schedule) then the method of proportion will be applied to the nearest analogous group of items available in both the Schedules referred to i.e. in the same proportion as the total tendered cost of that particular group of items (the sum of the products of the tendered rates and the quantities for which orders are placed bears to the total cost of the same items and quantities at the B.H.E.L Schedule of Rates.

- c. If even an appropriate analogous group of items is not available in Contractor's Schedule and B.H.E.L Schedule, then the methods of proportion will be applied to all those items of the whole work, which are available in both the Schedules and for which orders have been placed on the contractor, i.e., in the same proportion as the total cost of all these items of work (the sum of the products of the tendered rates and the quantities for which orders are placed) bears to the total cost of the same items and qualities at the B.H.E.L Schedule of Rates.
- II. If any work not covered by any of the foregoing is ordered on the Contractor, the basis of payment shall be decided by the Accepting Officer whose decision shall be final and conclusive and binding on the parties.

The selection of analogous items or analogous group of items referred to above shall be done by the Engineer-in-charge. Where the rates for deviated items or new items of work can be derived by the selection of different analogous items or analogous group of items, the lowest of all such derived rates shall be taken as the correct rate.

In the case of the contracts for which the Engineer-in-charge is the Accepting Officer, all disputes regarding the settlement of rates of deviated or new items or work shall be referred to the Deputy Manager/Manager whose decision shall be final and conclusive as the case may be.

51. Reimbursement / Refund on Variation in Price, Materials:

If after submission of the tender and/or during the progress of the works, the price of any material (not being a material supplied from the B.H.E.L store in accordance with the Conditions of the Contract) is increased or decreased by an Act of Legislature (Central or State) and/or any notification there under or on account of new duties or levies such as octroi or on account of increase or decrease in such duties affecting the price of materials required for incorporation in the works and made from materials of

which the price has increased or decreased as aforesaid and the Contractor has thereupon to pay in respect of such material or item a price which is higher or lower than the price of that material or item as prevailing immediately before the passing of such Act or levying, increasing/ decreasing of such duty, the B.H.E.L shall incase of increase in price or the duty reimbursed to the contractor and incase of decrease in price, the B.H.E.L shall be entitled to a refund of the reduction price or the reduction in duty. Provided, however no reimbursement or refund shall be made if the increase/decrease is not more than 10% of the said price, and if so, the reimbursement or refund shall be made only on the excess over 10% provided always that any such increase shall not be payable if, in the opinion of the Deputy Manager/Manager (whose decision shall be final and conclusive) the increase is attributable to the delay in the execution of the contract within the control of the contractor or that any such increase has become operative after the contracted/or extended date of completion of the work or items of work in question.

The Contractor shall, for the purpose of this condition, keep such books of account and other documents as are necessary to show the amount of any increase claimed or any reduction available and shall allow inspection of the same by any

CIVIL ENGINEERING DEPARTMENT, BHEL, TRICHY-14

duly authorized representative of the B.H.E.L and further shall at the request of the Engineer-in-charge furnish for verification such other information of the Engineer-in-charge may require.

The Contractor shall within a reasonable time of his becoming, aware of any alteration in the prices of any such materials, give notice thereof in writing to the Engineer-in-charge stating that the rate is submitted in pursuance to this condition together with all information relating thereto which he may be in a position to supply.

52. Advances on Account:

No payment shall be made for work estimated to cost less than Rupees **FIVE THOUSAND** till the whole of the work shall have been completed and a certificate of completion given by the Competent Authority.

In the case of work estimated to cost more than Rupees **FIVE THOUSAND** the contractor may at intervals of not less than one month or as otherwise provided for in the Contract Documents, counting from the date on which order to commence work is given by Engineer-in-charge submit claims on B.H.E.L forms for payment of advances on account of work done and of materials delivered in connection with the Contract.

The contractor shall be paid in respect of such claims to the extent approved and passed by the Engineer-in-charge subject a maximum of 90% of the value of the work actually executed to the satisfaction of the Engineer-in-charge. The certificate of the Engineer-in-charge regarding such approval and passing of the sums so payable shall be final and conclusive against the Contractor.

“After the full amount of Security Deposit is made up through the 10% deduction from On account” bills, 100% payment of all subsequent bills may be made to the Contractor.

The Contractor may also be paid during the progress of the work 75% of the value of any materials which are in the opinion of the Engineer-in-charge in accordance with the Contract, and are actually required for incorporation in the work and which have reasonably been brought to the site in connection therewith and are adequately stored and / or protected against damage by weather or other causes, but which have not at the time of payment of the advance been incorporated in the work on furnishing a formal hypothecation deed. Payment of such advances, however, shall be purely at the discretion of the Deputy Manager/Senior Engineer provided always that payments shall not be made under these periodical certificates in respect of perishable materials like lime, cement, timber, sand, kankar, etc., Any sums/due from the Contractor on account of Tools and Plant, Stores or any other items provided by B.H.E.L shall be deducted from the respective advances, the Engineer-in-charge shall from time to time certify the sums payable to the contractor after retaining the reserves.

Any certificate relating to work done or materials delivered may be modified or corrected by any subsequent interim certificate or by the final certificate and no certificate of the Engineer-in-charge supporting an advance payment shall itself be conclusive evidence that any work or materials to which it relates are in accordance with the contract. All such intermediate payments shall be regarded

CIVIL ENGINEERING DEPARTMENT, BHEL, TRICHY-14

as advances against the final payment only and shall not be considered as an admission of the due performance of the contract or any part thereof in any respect or the accruing of any claim whatsoever.

Such intermediate payment shall not conclude, determine or affect in any way the powers of the Engineer-in-charge as to the final settlement and adjustment of the accounts or otherwise, or in any way vary or affect the contract.

53. Final Bill

As soon as possible after the completion of the work to the satisfaction of the Engineer-in-charge, the contractor shall forward a certified final account on BHEL form, in duplicate.

It shall be accompanied by all abstracts, vouchers etc., in support thereof and shall be prepared in the manner prescribed by the Engineer-in-charge.

No claims will be entertained after the receipt of the final bill.

The Contractor shall be entitled to be paid the final sum less the value of payments already made on account subject to certification of the final bill by the Engineer-in-charge. Any sums due from the contractor on account of Tools & Plant, Stores or any other items provided by BHEL not yet recovered from the contractor shall be deducted from the final sum aforesaid.

No charge shall be allowed to the Contractor on account of the preparation of the final bill.

54. Payment of Bills

~~All payment to be made to the Contractor under this contract shall be by "Crossed Cheque" marked 'A/C payee only (Within a reasonable time after the Certification by the Engineer in charge) at the State Bank of India or their subsidiaries located in the station where either the work is executed or service rendered or at their branch nearest to the station where the Officer of the Engineer in charge is located.~~

All payment to be made to the Contractor under this contract shall be by the National Electronic Funds Transfer and/or RTGS Transfer mode by credit to mentioned Bank Account in the EFT form attached with this qualification bid

55. Recovery from Contractor:

Whenever under the contract any sum of money shall be recoverable from or payable by the contractor the same may be deducted from any sum then due or which at any time thereafter may become due to the Contractor under the contract or under any other Contract with BHEL or from his Security Deposit or he shall pay the claim on demand.

56. Post Technical Audit of Work and Bills:

BHEL reserves the right to carry out a post-payment audit and technical examination of the work and final bill including all supporting vouchers, abstracts etc., and to enforce recovery of any sums becoming due as a result thereof in the manner provided in the preceding sub-paragraphs provided however that no such recovery shall be enforced after three years of passing the final bill.

57. Refund of Security Deposit:

50% of the Security Deposit mentioned in condition 16 above, may be refunded to the contractor in respect of all contracts on completion of work and after payment of final bill and the balance 50% on expiry of the maintenance period, (described under clause 23) provided the contractor shall have rendered a "No-Demand" Certificate. In case of works where maintenance period is not involved 100% of the Security Deposit may be refunded after payment of final bill provided that the contractor shall have rendered a "No-Demand Certificate".

58. Arbitration:

Except where otherwise provided for in the contract all questions and disputes relating to the meaning of the specifications, designs, drawings and instructions hereinbefore mentioned and as to the quality of workmanship or materials used on the work or as to any other question, claim, right, matter or thing whatsoever in any way arising out of or relating to the contract, designs, drawings, specifications, estimates, instructions, orders or these conditions or otherwise concerning the work or failure to execute the same whether arising during the progress of the work or after the completion or abandonment thereof shall be referred to the sole arbitration of the Executive Director / General Manager of BHEL and if ED is unable or unwilling to act, to the sole arbitration of some other person appointed by the ED / General Manager, willing to act as such arbitrator. The cases referred to arbitration shall be other than those for which the decision of the Manager / Senior Engineer / Engineer-in-charge is expressed in the contract to be final and conclusive. There will be no objection if the arbitrator so appointed is an employee of B.H.E.L and that he had to deal with the matters to which the contract relates and that in the course of his duties as such he had expressed views on all or any of the matters in dispute or difference.

The arbitrator to whom the matter is originally referred being transferred or vacating his office or being unable to act for any reason, such Executive Director / General Manager as aforesaid at the time of such transfer, vacation of office or inability to act, shall appoint another person to act as arbitrator in accordance with the terms of the contract. Such person shall be entitled to proceed with the reference from the stage at which it was left by his predecessor.

Subject as aforesaid the provision of the Arbitration & Reconciliation Act, 1996 or any statutory modification or re-enactment thereof and the rules made there under and for the time being in force shall apply to the arbitration proceeding under this clause.

It is a term of the contract that the party involving arbitration shall specify the dispute or disputes to be referred to arbitration under this clause together with the amount or amounts claimed in respect of each such dispute.

The arbitrator(s) may from time to time with consent of the parties enlarge the time for making and publishing the award.

The work under the Contract shall, if reasonably possible, continue, during the arbitration proceedings and no payment due or payable, to the Contractor shall be withheld on account of such proceeding.

The Arbitrator shall be deemed to have entered on the reference on the date he issues notice to both the Parties fixing the date of first hearings.

The arbitrator shall give a separate award in respect of each dispute or difference referred to him.

CIVIL ENGINEERING DEPARTMENT, BHEL, TRICHY-14

The venue of arbitration shall be such place as may be fixed by the Arbitrator in his sole discretion.

The award of the arbitrator shall be final, conclusive and binding on all parties to this contract.

In the event of disputes or differences arising between one public sector enterprise and a Govt. Department or between two public sector enterprises the above stipulations shall not apply the provisions of BPE office memorandum No. BPE/CL 001/ 76MAN / 2 (1.10) 75-BPE (GM-1) dated 1st January 1976 or its amendments for arbitration shall be applicable.

ANNEXURE 'A'

B.H.E.L CONTRACTOR'S LABOUR REGULATIONS

(See condition 20)

1. Definition:

In these regulations, unless otherwise expressed or indicated, the following words and expressions shall have the meaning hereby assigned to them.

- a) "Labour" means workers employed by a contractor directly, or indirectly through a sub-contractor, or by an agent on his behalf on a payment not exceeding Rs.500 per month.
- b) "Fair Wage" means wages, which shall include wages for weekly day of rest and other allowances, whether for time or piece work, after taking into consideration prevailing market rates for similar employments in the neighborhood but shall not be less than the minimum rates of wages fixed under the minimum Wages Act.
- c) "Contractor" for the purpose of these Regulations shall include an agent or Sub-Contractor employing labour on the work taken on contract.
- d) "Inspecting Officer" means any Labour Enforcement Officer, or Assistant Labour Commissioners of the Chief Labour Commissioner's Organisation.
- e) "Form" means a form appended to these Regulations.

2. Notice of Commencement :

The Contractor shall, within **SEVEN DAYS** of commencement of the work, furnish in writing to the Inspecting Officer of the area concerned the following information with copy to the Engineer-in-charge.

- a) Name and situation of the work.
- b) Contractor's name and address.
- c) Particulars of the Department for which the work is undertaken.
 - d) Name and address of sub-contractors as and when they are appointed
 - e) Commencement and probable duration of the work
 - f) Number of workers employed and likely to be employed,
 - g) 'Fair wages' for different categories of workers.

3. (i) Number of hours which shall constitute a normal working day:

CIVIL ENGINEERING DEPARTMENT, BHEL, TRICHY-14

The number of hours which shall constitute a normal working day for an adult shall be **NINE** hours. The working day of an adult worker shall be so arranged that of intervals, if any, for rest it shall not spread over more than twelve hours on any day. When an adult worker is made to work for more than **NINE** hours on any day or for more than **FORTY EIGHT** hours in any week he shall in respect of overtime work, be paid wages at double the ordinary rate of wages.

- (ii) Weekly day of rest: Every worker shall be given a weekly day of rest which shall be fixed and notified atleast **TEN** days in advance. A worker shall not be required or allowed to work on the weekly rest day unless he has or will have a substituted rest day, on one of five days immediately before or after the rest day. Provided that no substitution shall be made which will result in the worker working for more than ten days consecutively without a rest day for a whole day.

Where in accordance with the foregoing provisions a worker works on the rest day and has been given a substituted rest day he shall be paid wages for the work done on the weekly rest day at the overtime rate of wages.

NOTE: The expression 'Ordinary rate of wages' means the fair wage the worker is entitled to.

4. Display of Notice Regarding Wages, Weekly Day of Rest, Etc.:

The Contractor shall before he commences his work on contract display and correctly maintain and continue to display and correctly maintain in clean and legible condition in conspicuous places on the works, notice in English and in the local Indian languages, spoken by majority of workers, given the rate of fair wages, the hours of work for which such wages are payable, the weekly rest days workers are entitled to and name and address of the Inspecting Officer. The Contractor shall send a copy each of such notices to the Inspecting Officers and the Engineer-in-charge.

5. Fixation of Wage Periods:

The Contractor shall fix wage periods in respect of which wages shall be payable . No wage period shall normally exceed one week.

6. Payment of Wages:

Wages due to every worker shall be paid to him direct. All wages shall be paid in current coins or currency or in both.

Wages of every worker employed on the contract shall be paid where the wage period is one week, within, **THREE DAYS** from the end of the wage period, and in any other case before the expiry of the 7th day or 10th day from the end of the wage period according as number of workers does not exceed 1,000.

- (i) When employment of any worker is terminated by or on behalf of the contractor, the wages earned by him shall be paid before expiry of the day succeeding the one on which his employment is terminated.

CIVIL ENGINEERING DEPARTMENT,BHEL,TRICHY-14

- (ii) Payment of wages shall be made at the work site on a working day except when the work is completed before expiry of the wage period, in which case final payment shall be made at the work site within 48 hours of the last working day and during normal working time.

NOTE: The term "Working Day" means a day on which the work on which labour is employed is in progress.

7. Register of Workmen :

A register of workmen shall be maintained in the form appended to these regulations and kept at the work site or as near to it as possible, and the relevant particulars of every workmen shall be entered therein within **THREE** days of his employment.

8. Employment Card:

The Contractor shall issue an employment card in the Form appended to these regulations to each worker on the day of work or entry into his employment. If a worker has already any such card with him issued by the previous employer the contractor shall merely endorse that Employment Card with relevant entries. On termination of employment the Employment Card shall again be endorsed by the Contractor and returned to the worker.

9. Register of Wages etc., :

- (i) A register of Wages-cum-Muster Roll in the Form appended to these regulations shall be maintained and kept at the work site or as near to it as possible.
- (ii) A wage slip in the form appended to these regulations shall be issued to every worker employed by the Contractor atleast a day prior to disbursement of wages.

10. Fines and Deductions which may be made from wages:

- (i) Wages of worker shall be paid to him without any deductions of any kind except the following:
 - a. Fines;
 - b. Deductions for absence from duty, i.e., from the place or the places where by the terms of his employment he is required to work. The amount of deduction shall be in proportion to the period for which he was absent.
 - c. Deduction for damage to or loss of goods expressly entrusted to the employed person for custody, or for loss of money which he is required to account for, where such damage or loss is directly attributable to his neglect or default;
 - d. Deductions for recovery of advances or for adjustment of overpayment of a wages. Advance granted shall be entered in a register;

CIVIL ENGINEERING DEPARTMENT, BHEL, TRICHY-14

and

- e. Any other deduction, which the B.H.E.L may from time to allow.
 - ii. No fines shall be imposed on a worker save in respect of such acts and omissions on his part as have been approved by the Chief Labour Commissioner.
 - iii. No fines shall be imposed on a worker and no deductions for damage or loss shall be made from wages until the worker has been given an opportunity of showing cause against such fines or deductions.
 - iv. The total amount of fines which may be imposed in any one wage period on a worker shall not exceed an amount equal to three paise in rupee of the wages payable to him in respect of that wage period.
 - v. No fine imposed on a worker shall be recovered from him in instalments, or after expiry of sixty days from the date on which it was imposed. Every fine shall deemed to have been imposed on the day of the act or omission in respect of which it was imposed.
 - vi. The Contractor shall maintain both in English and the local Indian language a list, approved by the Chief Labour Commissioner, clearly stating the acts and omissions for which penalty or fine may be imposed on a workman and display it in good condition in a conspicuous place on the work site.
 - vii. The Contractor shall maintain a register of fines and the register of deductions for damage or loss in the Forms appended to these regulations which should be kept at the place of work.

11. Register of Accidents :

The Contractor shall maintain a register of accidents in such form as may be convenient at the work place but the same shall include the following particulars:

- a. Full particulars of the labourers who met with the accident.
- b. Rates of Wages.
- c. Sex
- d. Age
- e. Nature of accident and cause of accident.
- f. Time and date of accident.
- g. Date and time when admitted in hospital.
- h. Date of discharge from the hospital.
- i. Period of treatment and result of treatment.
- j. Percentage of loss of earning capacity and disability as assessed by Medical Officer.
- k. Claim required to be paid under Workmen's Compensation Act.
- l. Date of payment of compensation.
 - m. Amount paid with details of the person to whom the same was paid.
- n. Authority by whom the compensation was assessed.
- o. Remarks.

CONTRACTOR

116

ACCEPTING OFFICER

12. Preservation of Registers :

The Register of Wages-cum-Muster Roll required to be maintained under these Regulations shall be preserved for 3 years after the date on which last entry is made therein.

13. Enforcement :

The Inspecting Officer shall either on his own motion or on a complaint received by him carry out investigations, and send a report to the Engineer-in-charge specifying the amounts representing workers, dues and amount of penalty to be imposed on the contractor for breach of these Regulations, that have to be recovered from the contractor, indicating full details of the recoveries proposed and the reasons therefore. It shall be obligatory on the part of the Engineer-in-Charge on receipt of such a report to deduct such amounts from payments due to the contractor.

14. Disposal of amounts recovered from the Contractor :

The Engineer-in-charge shall arrange payment to workers concerned within **FORTY FIVE** days from receipt of a report from the Inspecting Officer except in cases where the contractor had made an appeal under Regulation, 16 of these Regulations. In cases where there is an appeal, payments of workers, due would be arranged by the Engineer-in-charge, wherever such payments arise, within **THIRTY** days from the date of receipt of the decision of the Regional Labour Commissioner (R.L.C.).

15. Welfare Fund:

All money that are recovered by the Engineer-in-charge by way of workers, due which could not be disbursed to workers within the time-limit prescribed above, due to reasons such as where-about of workers not being known, death of a worker, etc., and also amounts recovered as penalty, shall be credited to a fund to be kept under the custody of B.H.E.L for such benefit and welfare of workmen employed by contractors.

16. Appeal against decision of Inspecting Officer :

Any person aggrieved by a decision of the Inspecting Officer may appeal against such decision to the Regional Labour Commissioner concerned within THIRTY days from the date of the decision, forwarding simultaneously a copy of his appeal to the Engineer-in-charge. The decision of the Regional Labour Commissioner shall be final and binding upon the Contractor and the workmen.

17. Representation of Parties:

- i. A workman shall be entitled to be represented in any investigation or enquiry under these Regulations by an Officer of a registered trade union of which the said trade union is affiliated or where the workman is not a member of any registered trade union, by an Officer of a registered trade union connected with, or any other workmen employed in the industry in which the worker is employed.

- ii. A Contractor shall be entitled to be represented in any investigation or enquiry under these Regulations by an officer of an association of contractors of which he is a member or by an officer of a Federation of Associations of Contractors to which the said association is affiliated or where the contractor is not a member of any association of employers, connected with, or by any other employer engaged in the industry in which the contractor is engaged.
- iii. No party shall be entitled to be represented by a legal practitioner in any investigation or enquiry under these Regulations.

18. Inspection of Books and other Documents:

The Contractor shall allow inspection of the Register and other documents prescribed under these Regulations by Inspecting Officer and the Engineer-in-charge or his authorized representative at any time and by the worker or his agent on receipt of due notice at a convenient time.

19. Interpretation etc.

On any question as to the application, interpretation or effect of the Regulations the decision of the Chief Labour Commissioner or Deputy Chief Labour Commissioner (Central) shall be final and binding.

20. Amendments:

Central Government may, from time to time, add to or amend the Contractor's Labour Regulations and issue such directions as it may consider necessary for the proper implementation of the Contractor's Labour Regulations or for the purpose of removing any difficulty which may arise in the administration thereof, based on which the B.H.E.L., Contractor's Labour Regulations herein contained shall be subject to revision.

**MODEL RULES FOR LABOUR WELFARE
(See Condition 20)**

1. Definition:

- (a) 'Workplace' means a place at which, on an average, twenty or more workers are employed.
- (b) 'Large Workplace' means a place at which on an average, 500 or more workers are employed.

- 2. First Aid:** At every workplace, there shall be maintained in a readily accessible place first-aid appliances including an adequate supply of sterilized dressings and sterilized cotton wool as prescribed in the Factory Rules of the State in which the work is carried on. The appliances shall be kept in good order and, in large work places, they shall be placed under the charge of a responsible person who shall be readily available during working hours.

At large workplaces, where hospital facilities are not available within easy distance of the works First Aid posts shall be established and be run by a trained compounder.

CIVIL ENGINEERING DEPARTMENT, BHEL, TRICHY-14

Where large workplaces are remotely situated and far away from regular hospitals an indoor ward shall be provided with one bed for every 250 employees.

Where large workplaces are situated in cities, towns or in their suburbs and no beds are considered necessary owing to proximity of city or town hospitals, suitable transport shall be provided to facilitate removal of urgent cases to these hospitals. At other workplaces, some conveyance facilities shall be kept readily available to take injured person or persons suddenly taken seriously ill, to the nearest hospital.

At large workplaces there shall be provided and maintained an ambulance room of the prescribed sizes, containing the prescribed equipment and in the in-charge of such medical and nursing staff as may be prescribed. For this purpose the relevant provisions of the Factory Rules of the State Government of the area where the work is carried on may be taken as the prescribed standard.

- 3. **Accommodation for Labour:** The Contractor shall during the progress of the works provide, erect and maintain necessary temporary living accommodation and ancillary facilities for labour at his own expense and to standards and scales as approved by the Engineer-in-charge.
- 4. **Drinking Water:** In every workplace, there shall be provided and maintained at suitable places, easily accessible to labour, a sufficient supply of cold water fit for drinking.

Where drinking water is obtained from an intermittent public water supply each workplace shall be provided with storage where drinking water shall be stored. Every water supply storage shall be at a distance of not less than 15 meters from any latrine drain or other source of pollution. Where water has to be drawn from an existing well, which is within such proximity of latrine drain or any other source of pollution, the well shall be properly chlorinated before water is drawn from it for drinking. All such wells shall be entirely closed in and be provided with a trap door which shall be dust and water-proof.

A reliable pump shall be fitted to each covered well, the trap door shall be kept locked and opened only for cleaning or inspection which shall be done at least once a month.

- 5. **Washing and Bathing places:** Adequate washing and bathing places shall be provided separately for men and women. Such places shall be kept in clean and drained condition.
- 6. **Scale of Accommodation in Latrines and Urinals:** These shall be provided within the precincts of every workplace latrines and urinals in an accessible place, and the accommodation, separately for each of these, shall not be less than at the following scales:

	No. of Seats
a) Where number of persons does not exceed 50	2
b) Where number of persons exceed 50 but does not exceed 100	3
c) For additional persons	3

Per 100 or part thereof.

In particular cases, the Engineer-in-charge shall have the power to increase the requirement, where necessary.

7. **Latrines and Urinals:** Except in workplaces provided with water flushed latrines connected with a waterborne sewage system, all latrines shall be provided with receptacles on dry-earth system which shall be cleaned at least four times daily and at least twice during working hours and kept in a strictly sanitary condition. Receptacles shall be tarred inside and outside at least once a year.

If women are employed, separate latrine and urinals, screened from those for men and marked in the vernacular in conspicuous letters "For Women only" shall be provided on the scale laid down in rule 6. Those for men shall be similarly marked "For Men only" A poster showing the figure of a man and of a woman shall also be exhibited at the entrance to latrines for each sex. There shall be adequate supply of water close to latrines and urinals.

8. **Construction of Latrines:** Inside walls shall be constructed of masonry or other non-absorbent material and shall be cement-washed inside and outside at least once a year. The dates of cement washing shall be noted in a register maintained for the purpose and kept available for inspection. Latrines shall have at least thatched roof.
9. **Disposal of Excreta:** Unless otherwise arranged for by the local sanitary authority, arrangement for proper disposal of excreta by incineration at the workplace shall be made by means of a suitable incinerator approved by the local medical health and municipal or cantonment authorities. Alternatively local excreta may be disposed off by putting a layer of night soil at the Bottom of pucca tank prepared for the purpose and covering it with a 15 cm. layer of waste or refuse and then covering it with a layer of earth for a fortnight (when it will turn into manure).

The contractor shall, at his own expenses, carry out all instruction issued to him by the Engineer-in-charge to effect proper disposal of soil and other conservancy work in respect of Contractor's work-people or employees on the Site. The Contractor shall be responsible for payment of any charges which may be levied by municipal or cantonment authority for execution of such work on his behalf.

10. **Provision of shelters during rest:** At every workplace there shall be provided, free of cost, four suitable sheds, two for meals and two others for rest, separately for use of men and women labour. Height of each shelter shall not be less than 3 meters from floor level to lowest part of roof. Sheds shall be kept clean and space provided shall be on the basis of at least 0.5 sq.m. per head.
11. **Crèches:** At a place at which 20 or more women workers are ordinarily employed, there shall be provided at least one hut for use of children under the age of 6 years of such women. Huts shall not be constructed to a standard lower than that of thatched roof, mud floor and walls with wooden planks spread over mud floor and covered with matting.

Huts shall be provided with suitable and sufficient openings, for light and ventilation. There shall be adequate provision of sweepers to keep the places clean. There shall be two 'dais' in attendance. Sanitary utensils shall be provided to the

CIVIL ENGINEERING DEPARTMENT, BHEL, TRICHY-14

satisfaction of local medical, health and municipal or cantonment authorities. Use of huts shall be restricted to children, their attendants and mothers of children.

When the number of women workers is more than 25 but less than 50, the Contractor shall provide at least one hut and one Dais to look after children of women workers.

Size of crèche (s) shall vary according to the number of women workers employed. Creche(s) shall be properly maintained and necessary equipment like toys, etc. provided.

12. **Canteen:** A cooked food canteen on a moderate scale shall be provided for the benefit of workers wherever it is considered necessary.
13. Planning, setting and erection of the above mentioned structures shall be approved by the Engineer-in-charge, and the whole of such temporary accommodation shall at all times during the progress of the works be kept tidy and in a clean and sanitary condition to the satisfaction of the Engineer-in-Charge and at the Contractor's expense. The Contractor shall conform generally to sanitary requirements of local medical, health and municipal or cantonment authorities and at all times adopt such precautions as may be necessary to prevent soil pollution of the site.

On completion of the works the whole of such temporary structures shall be cleared away, all rubbish burnt, excreta or other disposal pits or trenches filled in and effectively sealed off and the whole of site left clean and tidy to the entire satisfaction of the Engineer-in-Charge, and at the Contractor's expenses.

14. **Anti-malarial precautions:** The Contractor shall, at his own expense, conform to all anti-malarial instructions given to him by the Engineer-in-charge, including filling up of any borrow pits which may have been dug by him.
15. **Enforcement:** The Inspecting Officer mentioned in the Contractors Labour Regulations or any other officer nominated in his behalf by the Engineer-in-Charge shall report to the Engineer-in-Charge all cases of failure on the part of the Contractor and or his sub-contractors to comply with the provisions of these Rules either wholly or in part and the Engineer-in-Charge shall impose such fines and other penalties as are prescribed in the conditions.

B.H.E.L SAFETY CODE

See Condition-20

1. Suitable scaffolds shall be provided for workmen for all work that cannot safely be done from the ground, or from solid construction except such short period of work as can be done safely from ladders. When a ladder is used an extra mazdoor shall be engaged for holding the ladder and if the ladder is used for carrying materials as well, suitable footholds and hand-holds shall be provided on the ladder and the ladder shall be given an inclination not steeper than $\frac{1}{4}$ to 1 ($\frac{1}{4}$ horizontal and 1 vertical)
2. Scaffolding or staging more than 3.25 meters above the ground or floor, swung or suspended from an overhead support or erected with stationary support, shall

CIVIL ENGINEERING DEPARTMENT, BHEL, TRICHY-14

have a guard rail properly attached, bolted, braced and otherwise secured at least 1 meter high above the floor or platform of such scaffolding or staging and extending along the entire length of the outside and ends thereof with only such openings as may be necessary for the delivery of materials. Such scaffolding or staging shall be so fastened as to prevent it from swaying from the building or structure.

3. Working platform, gangways, and stairways shall be so constructed that they do not sag unduly or unequally, and if height of a platform or gangway or stairway is more than 3.25 meters above ground level or floor level, it shall be closely bordered have adequate width and be suitably fenced, as described in 2 above
4. Every opening in floor of a building or in a working platform shall be provided with suitable means to prevent fall of persons or materials by providing suitable fencing or railing with a minimum height of 1 meter.
5. Safe means of access shall be provided to all working platforms and other working places. Every ladder shall be securely fixed. No portable single ladder shall be over 9 meters in length. Width between side rails in a rung, ladder shall in no case be less than 30 cm, for ladders upto and including 3 metres in length. For longer ladders this width shall be increased by at least 6 mm for each additional 30 cm. of length. Uniform step spacing shall not exceed 30 cm.

Adequate precautions shall be taken to prevent danger from electrical equipment. No materials on any of the sites shall be so stacked or placed as to cause danger or inconvenience to any person or the public. The Contractor shall provide all necessary fencing and lights to protect public from accidents and shall be bound to bear expenses of defence of every suit action or other proceedings at law that may be brought by any person for injury sustained owing to neglect of the above precautions, and pay any damages and costs which may be awarded in any such suit, action or proceeding to any such person or which may with the consent of the Contractor be paid to compromise any claim by any such person.

6. Excavation and Trenching:

All trenches, 1.5 metres or more in depth, shall at all times be supplied with at least one ladder for each 30 m length or fraction thereof. Ladder shall be extended from bottom of trench to at least 1 metre above surface of the ground. Sides of a trench 1.5 metres or more in depth shall be stepped back to give suitable slope or securely held by timber bracing, so as to avoid the danger of sides collapsing. Excavated materials shall not be placed within 1.5 metres of the edge of trench or half the depth of trench, whichever is more. Cutting shall be from top to bottom. Under no circumstances shall undermining or undercutting be done.

7. **Demolition:** Before any demolition work is commenced and also during the process of the work:
 - a. All roads and open areas adjacent to the work site shall either be closed or suitably protected:
 - b. No electric cable or apparatus which is liable to be a source of danger over a cable or apparatus used by the operator shall remain electrically charged.

CIVIL ENGINEERING DEPARTMENT, BHEL, TRICHY-14

- c. All practical steps shall be taken to prevent danger to persons employed, from risk of fire or explosion, or flooding. No floor, roof, or other part of a building shall be so overloaded with debris or materials as to render it unsafe.
8. All necessary personal safety equipment as considered adequate by the Engineer-in-Charge shall be available for use of persons employed on the site and maintained in a condition suitable for immediate use and the Contractor shall take adequate steps to ensure proper use of equipment by those concerned.
 - a. Workers employed on mixing asphaltic materials cement and lime mortars/ concrete shall be provided with protective footwear and protective gloves.
 - b. Those engaged in handling any material which is injurious to the eye shall be provided with protective goggles.
 - c. Those engaged in welding works shall be provided with welder's protective eye-shields.
 - d. Stone breaker shall be provided with protective goggles and protective clothing and seated at sufficiently safe intervals.
 - e. When workers are employed in sewers and manholes which are in use, the Contractor shall ensure that manhole covers are opened and manholes are ventilated atleast for an hour before workers are allowed to get into them. Manholes so opened shall be cordoned off with suitable railing and provided with warning signals or boards to prevent accident to public.

The Contractor shall not employ men below the age of 18 and women on the work of painting with products containing lead in any form. Whenever men above the age of 18 are employed on the work of lead painting, the following precautions shall be taken:

 - i. No paint containing lead or lead products shall be used except in the form of paste or ready-made paint.
 - ii. Suitable face masks shall be supplied for use by workers when paint is applied in the form of spray or a surface having lead paint is dry rubbed and scraped.
 - iii. Overalls shall be supplied by the Contractor to workmen and adequate facilities shall be provided to enable working-painters to wash during on cessation of work.
9. When work is done near any place where there is risk of drowning, all necessary equipment shall be provided and kept ready for use and all necessary steps taken for prompt rescue of any person in danger and adequate provision made for prompt first aid treatment of all injuries likely to be sustained during the course of the work.

CIVIL ENGINEERING DEPARTMENT, BHEL, TRICHY-14

10. Use of hoisting machine and tackles including their attachments, anchorage and supports shall conform to the following:
 - a.
 - i. These shall be of good mechanical construction, sound material and adequate strength and free from defects and shall be kept in good working order.
 - ii. Every rope used in hoisting or lowering materials or as a means of suspension shall be of durable quality and adequate strength, and free from defects.
 - b. Every crane driver or hoisting appliance operator shall be properly qualified and no person under the age of 21 years shall be in charge of any hoisting machine including any scaffolding winch or give signals to operator.
 - c. In case of every hoisting machine and of every chain, ring, hook, shackle, swivel and pulley block used in hoisting or lowering or as means of suspension, safe working load shall be ascertained by adequate means. Every hoisting machine and all gear referred to above shall have the safe working load plainly marked there on, In case of a hoisting machine having a variable safe working load, each safe working load and the conditions under which it is applicable shall be clearly indicated. No part of any machine or any gear referred to above in this paragraph shall be loaded beyond the safe working load except for the purpose of testing.
 - d. In case of departmental machine, safe working load shall be notified by the Engineer-in-Charge. As regards contractor's machine the Contractor shall notify safe working load of each machine to the Engineer-in-Charge whenever he brings it to site of work and get it verified by the Engineer-in-Charge.
11. Motors, gearing, transmission, electric wiring and other dangerous parts of hoisting appliances shall be provided with efficient safeguards; hoisting appliances shall be provided with such means as will reduce to the minimum risk of accidental descent of load. Adequate precautions shall be taken to reduce to the minimum risk of any part of a suspended load becoming accidentally displaced. When workers are employed on electrical installations which are already energized, insulating mats, working apparel such as gloves, sleeves and boots, as may be necessary shall be provided. Workers shall not wear any rings, watches carry keys or other materials which are good conductors of electricity.
12. All scaffolds, ladders and other safety devices mentioned or described herein shall be maintained in a safe condition and no scaffold, ladder or equipment shall be altered or removed while it is in use. Adequate washing facilities shall be provided at or near the places of work.
13. These safety provision shall be brought to the notice of all concerned by display on a notice board at a prominent place at the work spot. Persons responsible for ensuring compliance with the Safety Code shall be named thereon by the Contractor.
14. To ensure effective enforcement of the rules and regulations relating to safety precautions, arrangements made by the Contractor shall be open to inspection by the Engineer-in-Charge or his representatives and the Inspecting Officers as defined in the Contractor's Labour Regulations.

CIVIL ENGINEERING DEPARTMENT,BHEL,TRICHY-14

15. Notwithstanding the above conditions 1 to 14, the Contractor is not exempted from the operation of any other Act or Rule in force.

CIVIL ENGINEERING DEPARTMENT, BHEL, TRICHY-14

FORM OF REGISTER OF WORKMEN

(Regulation-7)

- i. Name and address of the Contractor-----
- i. Number and date of the **WORK ORDER & CONTRACT AGREEMENT** -----
- iii. Name and address of the department awarding the contract-----
- iv. Nature of the Contract and location of the work-----
- v. Duration of the Contract-----

Sl. No	Name and surname of the workers	Age &	Father's / Sex Name	Husband's	Nature of employment Designation.	Permanent / Home address of Employee (Village, Distt. Thana).	Present address of emp-	Date of commencement leaving	Date of termination or of the employment	Signature or thumb impression	Remarks
1	2	3	4	5	6	7	8	9	10	11	
	--										

CONTRACTOR

ACCEPTING OFFICER

**FORM OF EMPLOYMENT CARD
(Regulation-8)**

- i Name and Sex of the Worker-----
- ii Father's / Husband's Name -----
- iii Address -----
- iv Age or Date of birth-----
- v Identification mark -----

Particulars of next of kin (wife/husband and children, if any, or of dependent next of kin in case the worker has no wife/ husband or child):-

Name-----

Full address of Dependents

(Specify Village, Dist., and State-----)

Sl. No	Name & Address of employer (specify Whether a contractor or a sub contractor).	Particulars of location of worksite and description of work done	Total period for which the worker is employed from..... to.....)	Actual number of days worked	Leave taken (No. of days specified).	Nature of Work done by the should be specified).	Wage rate worker.	Total rate With Particulars of unit in Case of Piece work.	REMARKS Wage earned Parti- Worker during the period shown Under Col.5.	Signature of the Employee by the
1	2	3	4	5	6	7	8	9	10	11

N.B:- For a worker employed at one time on piece-work basis and at another on daily wages, relevant entries in respect of each type of employment should be made separately.

CONTRACTOR

ACCEPTING OFFICER

FORM OF WAGE SLIP
(Regulation-9)

- i. Name of the Contractor -----
- ii. Place -----

1. Name of the worker with
father's / husband's name.
2. Nature of employment.
3. Wage period.
4. Rate of Wages payable
5. Total attendance / Unit of work done.
6. Dates on which overtime worked
7. Overtime Wages.
8. Gross Wages payable.
9. Total deductions (indicating
nature of deductions)
10. Net wages payable.
-

Contractor's Signature /
Thumb impression.

Employees' Signature/
Thumb impression.

CIVIL ENGINEERING DEPARTMENT, BHEL, TRICHY-14

FORM OF REGISTER OF FINES (Regulations No.10 vii)

Sl. No.	Name	Father's / Husband's name	Sex	Department	Nature and date of the offence for which fine imposed	Whether workmen showed cause against fine or not, if so, enter date	Rate of wages	Date and amount of fine imposed	Date on which fine realised	Remarks
1	2	3	4	5	6	7	8	9	10	11

CONTRACTOR

ACCEPTING OFFICER

CIVIL ENGINEERING DEPARTMENT, BHEL, TRICHY-14

FORM OF REGISTER OF WAGES-CUM-MUSTER ROLL

(Regulation – 9)

- i. Name and address of the Contractor-----
- ii. No. & Date of the Contract Agreement /Work Order-----
- iii. Name and address of the department awarding the Contract-----
- iv. Nature of the Contract and location of the work-----
- v. Duration of the Contract-----
- vi. Wage period-----

		Fair Wage Wages payable paid				Overtime Worked		Deduction from wages															
Serial Number	Name and Surname of the worker	Father's/Husband's name	Sex	Designation and Nature of work	Daily attendance (No. of units worked 1, 2, 3, 4, 5, 6, 7, 31)	Total attendance Units	Basic	D.A. & other allowance	Basic	D.A. & other allowance	Date	No. of hours.	Overtime wages earned.	Total wages paid	*Fine	Deduction for damage or loss	House rent	Recovery of advances	Other deductions	Net wages payable	Date of payment	Signature of thumb impression of the worker	Remarks
01	02	03	04	05	06	07	08	09	10	11	12	13	14	15	16	17	18	19	20	21	22	23	24
Reasons to be recorded in Column 24.																							

CONTRACTOR

ACCEPTING OFFICER

CIVIL ENGINEERING DEPARTMENT, BHEL, TRICHY-14

FORM OF REGISTER OF DEDUCTIONS FOR DAMAGES OR LOSS CAUSED TO THE B.H.E.L.
BY THE NEGLIGENCE OR DEFAULT OF THE EMPLOYED PERSONS

Regulation No 10 (vii)

Sl.No	Name	Father's / Husband's Name	Sex	Department	Damage or loss caused with date	Whether worked showed cause against deduction if so, enter date	Date & amount of deduction imposed	Number of Instal- ment, if any	Date on which total amount realised	Remarks
1	2	3	4	5	6	7	8	9	10	11

CONTRACTOR 131

ACCEPTING OFFICER

CIVIL ENGINEERING DEPARTMENT, BHEL, TRICHY-14

TERMS AND CONDITIONS REGARDING COMPLIANCE WITH VARIOUS LABOUR LAWS BY THE CONTRACTORS FOR BHEL

1. The Contractor shall not employ in connection with the work any person who has not completed 18 years of age.
2. The Contractor shall in respect of labour employed by him either directly or through subcontractors, comply with or cause to be complied with the following statutory provisions and rules and in regard to all matters provided therein.
 - a) The Contract Labour (Regulation & Abolition) Act 1970 and the related Tamil Nadu Rules.
 - b) The Minimum Wages Act 1948 and the related Tamil Nadu Rules.
 - c) The Payment of Wages Act 1936 and the related Tamil Nadu Rules.
 - d) The Factories Act 1948 and the related Tamil Nadu Rules.
 - e) The Employee's Provident Fund & Miscellaneous Provisions Act 1952.
 - f) The Employees State Insurance Act 1948.
 - g) The Workmen Compensation Act 1923.
 - h) The Industrial Disputes Act 1947.
 - i) **The Payment of Bonus Act 1965.**

and any other law or modifications to the above or to the Rules made thereunder from time to time.

REGISTRATION AND LICENSING

3. Every Contractor shall register his name with the Welfare Section of BHEL before taking up the work awarded to him by giving the following information and getting a Code Number :
 - a) The Name of the Contractor
 - b) Nature of Contract Work
 - c) Period of work
 - d) Number of maximum labour employed by him on any one day
 - e) License No. & Date (Applicable in case of contractor employing 20 or more workers)
 - f) Whether enrolled for PF, ESI, etc., and enrolment No.

This information is called for, for the purpose of informing the Inspectorate of Factories whenever they call for information regarding contracts.

4. The Contractor employing 20 or more workmen is required to obtain license from the authorities (The Deputy Chief Inspector of Factories / Assistant Commissioner of Labour as the case may be). The license shall be amended and / or renewed wherever, there is an increase in the workmen employed by him or in the event of contract being extended or renewed. The Contractor shall inform the licence number to the BHEL Management before taking up the work.
5. The Contractor (Licensed or unlicensed) shall promptly furnish every information and document required by BHEL authorities for the purpose of fulfilling their obligations as Principal Employer and / or Occupier of the Factory and shall render all necessary assistance for the same.

WAGES

6. The tenderer has to ensure payment of Minimum Wages as per Tamil Nadu State Minimum Wages as applicable under law from time to time.

The labourers engaged in this contract shall be paid additional payment as mentioned below in addition to the payment of Minimum wages as stated above.

- | | |
|--------------------------------|--------------------|
| a) Unskilled Worker | Rs. 3200 per month |
| b) Semi-skilled Worker | Rs. 3700 per month |
| c) Skilled Worker / Supervisor | Rs. 4100 per month |

Also the labourers shall be paid a minimum bonus which shall be 8.33% as per the payment of Bonus Act 1965 for the total wages paid (i.e) Payment of minimum wages and additional payment as mentioned above.

The Contractor shall have to remit EPF & ESI contributions at the rates applicable under law to the authorities concerned for the total wages paid (i.e) Payment of minimum wages and additional payment as mentioned above.

At present the Tamil Nadu State Government Minimum wages declared is enclosed for your reference (Ref. Page No.26). Normally the revision will be with effect from 1st April of every year. Tenderers are requested to quote their offer after taking into account of the above factor also.

7. The Contractor shall fix wage periods in respect of which wages shall be payable. No wage period shall exceed one month.
8. The Contractor shall ensure payment of wages to the contract labour employed by him within three days from the end of wage period in case the wage period is one week or a fortnight and in all other cases before 10th day of the following month.
9. All Payment of wages shall be made on working days at the work site and during the working time and on date notified in advance. In case the work is completed before the expiry of the wage period final payment shall be made within 48 hours of the last working day.
10. Where the employment of any worker is terminated by or on behalf of the Contractor, the wages earned by him shall be paid before the expiry of the second working day from the day on which his employment is terminated.
11. Wages due to every worker shall be paid to him direct or to the person authorized by him in this behalf. All wages shall be paid in current coin or currency in both.
12. The Contractor shall ensure the disbursement of wages in the presence of such authorized representative of BHEL Management.
13. The above payment shall be verified by the authorized officer / representative of BHEL with the following certificate of the payment sheet "Certified that the amount shown in Column No..... has been paid to the workmen concerned in my presence onat....."
14. A certificate of payment shall be furnished in duplicate by the Contractor to the Engineer in charge each month in Form 'A'.

CIVIL ENGINEERING DEPARTMENT, BHEL, TRICHY-14

15. A notice showing the wage period and the place and time of disbursement of wages shall be displayed at the place of work and a copy to be sent to the Welfare Department by the Contractor under acknowledgement.
16. Notices showing the rate of wages, weekly rest days, hours of work, wage period, date of payment of wages, names and addresses of the Inspector having jurisdiction, the date of unpaid wages shall be displayed in Tamil and English in conspicuous places at the establishment and at work site by the Contractor. The Contractor shall inform the BHEL Management every month the details of contract labour engaged for contract in this following form :
 - a) Serial Number
 - b) Location
 - c) Period of work
 - d) No. of contract labour engaged during the month
 - e) No. of days worked
 - f) No. of men worked
 - g) Wages paid to workersThe above statement shall be furnished to BHEL Management at the end of every month.

REGISTERS AND RECORDS AND COLLECTION OF STATISTICS

17. The following documents / formats under Contract Labour (Regulation & Abolition) Act 1970 and Tamil Nadu Rules thereunder shall be maintained by each contractor.
 - a) Register of persons employed by the Contractor
 - b) Employment Card
 - c) Service Certificate
 - d) Muster Roll, Wage Register, Deduction Register, Wage slip, Overtime Register, Register of Fines, Register of Advances etc.,
18. The Contractor shall display the abstract of the Contract Labour (Regulation&Abolition) Act and the Rules thereunder both in English and Tamil.
19. Half yearly Return shall be sent by the Contractor in duplicate to the Licensing Officer.
20. The Contractor shall submit the returns required under the Contract Labour (Regulation & Abolition) Act 1970 periodically to BHEL Management.
21. The Contractor shall without fail give upto date information in writing of the attendance of the workers employed by him.
22. The Contractor shall ensure that his workers keep and produce their Employment Card when coming to duty and take them back when leaving duty.
23. All the above registers and records shall be preserved in original for a period of three years. All the registers, records and notice maintained under the Act and rules shall be produced on demand by Inspector or any authority under the Act.

WORKING HOURS AND WORKING CONDITIONS

24. No worker shall be required or allowed to work on Sunday unless he has or will have a holiday on anyone of the three days before or after the said day.

CONTRACTOR

134

ACCEPTING OFFICER

CIVIL ENGINEERING DEPARTMENT, BHEL, TRICHY-14

25. The Contractor shall inform BHEL Management in the prescribed form details of the contract workers scheduled to work on Sunday, the day of rest and also indicate the substituted holiday in lieu thereof. This shall be intimated two days in advance before his workmen are booked for work on Sunday.
26. The contract labour working for more than nine hours in any day or for more than 48 hours in any week shall be paid wages at the rate of twice the ordinary rate of wages in accordance with the provisions of Sections 59 of the Factories Act 1948.
27. The Contractor shall provide all safety devices and personal protective equipment to his workmen at his own cost and shall ensure that his workmen wear / use such devices or equipment provided to them while doing the work and there should not be any relaxation on this.
28. The Contractor shall give four paid National Holidays to his workers, viz., 26th January, 1st May, 15th August and 2nd October.
29. The Contractor shall ensure that his workmen vacate the premises after the shift is over.
30. The Contractor shall give leave with wages to his workmen who have worked for a period of 240 days or more in the work premises during a calendar year. This leave shall be allowed during the subsequent calendar year at the rate of one day for every 20 days of work performed by the worker during the previous calendar year. The worker whose services commences on a day other than the first of January shall be entitled to leave with wages at the above rate (One day for every 20 days of work) only if he had worked for a minimum of 2 /3 of the total number of days in the remainder of the calendar year. This leave will be admissible only during the subsequent calendar year.
31. No woman worker shall be required or allowed to work in the Township except between the hours of 6.00 A.M. and 7.00 P.M.
32. The Contractor shall comply with the provisions relating to Welfare and Health facilities as provided in the Contract Labour (Regulation and Abolition) Act 1970 read with the Tamil Nadu Contract Labour Rules 1975.

NOTICE OF ACCIDENTS

33. Notwithstanding anything contrary to this, in the event of accident the contractor shall be required to fill injury report and submit the Engineer in charge immediately and ensure the compliances of ESI / Workmen's compensation Act, Factories Act and Rules made thereunder. He shall also maintain a register of accident as per the Act.
34. The Contractor shall get the contract labour engaged by him insured under Workmen's Compensation policy from General Insurance Corporation of India before actually starting the work of contract. The insurance coverage should be for the entire period of Contract. The Contract shall comply with the provisions of the Workmen's Compensation Act 1923. (This should be read in conjunction with the provisions of ESI Act)

COVERAGE UNDER THE ESI ACT / PF AND MISCELLANEOUS PROVISIONS ACT

CIVIL ENGINEERING DEPARTMENT, BHEL, TRICHY-14

35. The contractor shall ensure that all his workmen are covered under the Employee's State Insurance Act and produce to BHEL such Registration Number / Enrolment Number before executing the contract work.
36. The Contractor shall regularly pay the amount of contribution. i.e., employer's contributions as well as employees' contribution pursuant to the above scheme as fixed from time to time. The Contribution payable presently is 1.75% wages to be recovered from his workmen and 4.75% of wages to be contributed by the Contractor. Contributions recovered from employee and contribution made by the contractor may be rounded to the next higher multiples of five paise.
37. The Contractor shall take note of any amendment that may be brought forth in the above contribution rate and act accordingly.
38. The contractor shall ensure that his workmen are covered under the EPF & Miscellaneous Provisions Act 1952 and accordingly produce to the BHEL Management the registration / enrolment number before awarding of contract work. As per the existing provisions every worker shall be entitled and required to become a member of the fund. The employee's contribution payable at present is 12% of wages which will be recovered by the contractor from the wages of his workmen and the contractor should pay equal contribution. The contractor is also liable to pay any administrative charges in this behalf that may be decided from time to time. It will be the responsibility of the contractor to ensure such contribution payable in respect of workmen employed through sub-contractors also.
39. The Contractor shall take note of any amendment in the rate of contribution payable under the scheme from time to time.
40. The Contractor shall within seven days of the close of every month submit to BHEL a statement showing the amount of contribution payable / paid for employees engaged by him or through him and shall also furnish to BHEL such information as Principal Employer is required to furnish under the provisions of the ESI Act and PF as well as the schemes made thereunder to the authorities concerned.
41. Whenever any sum of money is found to be recoverable from or payable by the contractor under the above Act, the sum shall be deducted from any sum that may be due or which at any time thereafter may become due to the Contractor under this contract or under any other contract or from his security deposit. In case the recoveries are not sufficient to satisfy the claim, the contractor shall pay the balance thereof on demand. In case any recoveries are made under this clause from security deposit, the contractor shall immediately thereafter pay such further sums as may be required to replenish the shortage caused by such recoveries in amount of security deposit.
42. The Contractor shall abide by all the labour and other laws applicable to contract labour / worker under this contract and shall at all times keep BHEL indemnified against all losses, claims, prosecutions under any law.
43. In case of non-compliance of any of the provisions of the Acts and in case BHEL having complied with the same, BHEL will be entitled to recover the same from the contractor / sub-contractor.
44. Non-exercise of any of the powers or rights available to BHEL hereunder or under any law, shall not in any way operate as waiver thereof.

CIVIL ENGINEERING DEPARTMENT, BHEL, TRICHY-14

Note : The Specimen forms for the following are available in BHEL.

- | | | | |
|----|-----------|---|--|
| 1) | Form 'A' | - | Payment Certificate |
| 2) | Form IV | - | Application for License |
| 3) | Form XIII | - | Register of Workmen employed by contractor |
| 4) | Form XIV | - | Employment Card |
| 5) | Form XV | - | Service Certificate |
| 6) | Form XVI | - | Muster Roll |
| 7) | Form XVII | - | Register of wages |
| 8) | Form XIX | - | Wage slip |

GENERAL SAFETY PRECAUTIONS TO BE FOLLOWED AT WORK SITE DURING EXECUTION

The following safety measures should be strictly adhered to during execution of works at sites.

1. Providing the working platform with toe board and handrail for continuous working at heights.
2. Providing safety belt and life line at all times for men working at heights.
3. Providing dust or fume respirator in places where dust and fume concentration exists.
4. Providing goggles and welding screens.
5. Providing acid and alkali proof rubber gloves for handling acid and alkali and chemical which are corrosive.
6. Providing rubber gloves for working on electrical works.
7. Ensuring proper lashing of the components while being transported in vehicles.
8. The vehicles must have side supports or have body to support the materials conveyed.
9. The materials should not be allowed to extend or overflow the sides of the vehicles.
10. Materials should not be allowed to overhang from the rear edge of the body of the vehicle.
11. Driver of the vehicle must possess license.
12. Vehicle must not be overloaded prescribed limits.
13. Red flags and lights for parts projecting from the body of vehicle must be provided.
14. The speed restrictions within the Township premises must be strictly adhered to.
15. The gas cylinders must be always handled on trolleys or kept tied down not in use. They should never be rolled as Roller for conveying.
16. Cylinders should not be used without regulators.
17. All excavations must be barricaded and red lamps must be provided.
18. All electrical connections must be properly earthed.
19. No work should be taken up for execution inside shop floor, without obtaining necessary work permit.
20. Providing helmet, safety belt, etc., for high level work and sufficient number of Industrial Safety nets at appropriate level to safeguard the persons working at high level particularly in trusses, girders, roofing etc., of industrial and high roof buildings.
21. The contractor should maintain a register regarding the driver license particulars.
22. All personal protective equipment conform with standard specification as per the details given in the code of conduct.

Contractor including their sub contractors, agents and labour engaged on the work are required to scrupulously adhere to the safety regulations, safety precautions and measures. Any violation thereof will invite punitive action being taken against them. Also contractors with frequent violations of safety regulations will not be entrusted with further work in this organization.

SAFETY PRECAUTIONS TO BE OBSERVED WHILE TRANSPORTING MATERIALS

I. VEHICLE

1. Vehicles carrying material should have proper registration documents and must be produced on demand by our Security Staff.
2. The light on right side, i.e., over the drivers cabin shall be in working condition.
3. Both the head lights as well as park lamps must be in working conditions.

II. MOVEMENT OF VEHICLE

1. The vehicle should not travel at more than 20 km.ph in our premises.
2. The Driver of the vehicle must possess heavy duty licence and produce on demand by the Security Staff.
3. Vehicles carrying inflammable liquids in the tank containers should have grounding chain or the tank should be coated with insulating material also to avoid Static Electricity.
4. In road junctions, speed breakers and railway crossing, the speed should be lowered and vehicle should proceed cautiously.
5. The driving should 'KEEP TO THE LEFT' at all places.
6. The vehicle should not be parked in road which could obstruct the vehicular traffic.
7. No person other than driver should be allowed to sit or stand on the prime mover or trailer.
8. The vehicle should pass only through the approved routes. Short cuts should be forbidden.
9. There must be a safe distance behind another moving truck.
10. The driver should avoid making quick starts, jerky stops or quick turns at excessive speed.

III SHIPPING

1. Strong side supports should be provided on both sides of the trailer. The side supports should be fixed in such a way that it cannot be removed even temporarily.

CONTRACTOR

139ACCEPTING OFFICER

CIVIL ENGINEERING DEPARTMENT, BHEL, TRICHY-14

2. Adequate packing must be given for easy slinging operation. The packing materials should be good enough to withstand the load.
3. The stacking of loads in the truck should be evenly placed. The load should not be heaped together or dumped over the chassis.
4. The loaded materials should be fastened tightly with 'WIRE ROPE'. Manila rope or coir rope should not at all be used. There must be side packing such as gunny or rubber tyre between the sharp edge of the job and wire rope in order to avoid cut in the wire rope.
5. There must be minimum two fastenings and it should be more in case of lengthier loads.
6. The wire rope should be in sound conditions i.e, there should not be links, knots or bristles etc.,
7. The wire rope ends should be clamped with 'U' clamps.
8. The load on the truck should not be beyond its standard capacity. The carrying capacity must be clearly marked on the trailer also.
9. The loose pieces should be bundled before loading on the truck.
10. There must be red flags or red lamps for the lengthy loads which extend beyond chassis.
11. The load should not be over hanging more than 3 ft. from the end of the body.
12. The materials should not be stacked too high to avoid hitting against live electric lines.
13. While transporting the scraps, there must be wire knitting cover to prevent falling of scrap.

IV GENERAL

The vehicles should not be moved directly inside the production building in case the materials are to be unloaded there. But the vehicle should be parked outside the building and the driver should ascertain the passage as well as the unloading points with the help of shop officials. This will avoid the congestion of blocking of traffic in the gangway.

CONTRACTOR

140ACCEPTING OFFICER

BHEL-Trichy : Contractor Safety Guidelines

Following are the points to be ensured for the safety of contract employees.

I. Identity and Entry:

1. The contractors to give identity card to their employees with full details like employee name, company name, age, blood group, contact person with phone no. etc.
2. The contractors not to employ people whose age is below 18 years.
3. HR/Welfare will issue passes to the trained employees only.
4. Welfare has to arrange for necessary infrastructure (biometric entry) for enrolment of new contract workers. Biometric entry system will be made available in North Gate and Unit 2 initially.
5. The data of daily entry of contract workers through biometric will be made available online to the contract awarding departments HR/Welfare.

II. Training:

1. Safety, first aid and fire fighting training to be given to two responsible persons in each contract and they should take care of their groups on day to day working.
2. This shall be done within a period of 2 weeks after awarding of fresh contract.
3. For ongoing contracts the contractors has to identify the persons to be trained within a period of 2 weeks.
4. Driving/operation of Crane/jumbo/Fork lift etc are to be done only by authorized persons.

III. Dress Code:

1. Male employees should enter gates only with Safety shoes, Pants-Shirts, (Dothi, Lungi not permitted).
2. Female employees should enter gates only with Safety shoes. Loose dress must be avoided. (A shirt over saree / chudithar is a must).
3. Normal shoes are acceptable for office area work only.
4. Employees working in canteens can wear sandex.
5. Welfare will finalize and indicate a color coding to be provided in the dresses used by contract employees for uniformity and easy identification of the contract workers.

IV. Procedures:

1. Smoking, audio-playing (mobile phone, iPod, inbuilt music systems etc in the vehicles.) are banned within the factory premises.
2. Moving to unrelated areas must be strictly avoided by the contract employees entering to the other areas only with knowledge of concerned department.
3. Procedure (SOP) given from user departments are to be adopted for all operations and maintenance – e.g. tank cleaning, ET plant maintenance, Sewage maintenance, Oxidation pond maintenance, operation of substation, transformer maintenance etc. User departments agreed to generate procedures incase if not available already (Snake catching, Monkey catching, Honey comb removal etc.).
4. Adequate precautions to be taken while waste removal like paint sludge removal, chromic sludge removal, phenol and tar removal by contract employees.
5. The contractor should clearly inform the hazards involved to the employees MSDS to be displayed.
6. The contract employees involved in tank cleaning, ET plant maintenance, Oxidation pond maintenance should know swimming and strict monitoring should be ensured.
7. Line clearance(LOTO)procedure to be followed during bulb changing, electrical substation maintenance, DSL maintenance, furnace instrumentation etc.
8. Work permits to be obtained for jobs like work at height, excavation, blasting, hot work, pipe line work, roof light maintenance, work at confined space like cellar.
9. Users agreed to initiate the permits for all the works mentioned in the table given below to safety mgt for clearance.

BHEL-Trichy : Contractor Safety Guidelines

Work Permit Instructions

SI No	Works	Instruction
1	Construction, erection & Commission of new and modification of existing civil structure	The contract workers employed shall have sufficient job knowledge shall follow the procedures and dress code
2	Periodical Civil maintenance work at height	Only experienced people shall be allowed to carry out the work at height. Physically fit without any vertigo problem. Wear safety belt and use life line, Net etc.
3	Work at height - including roof light maintenance and furnace work	Only experienced and qualified electrician shall be allowed to carry out the work at height. Physically fit without any vertigo problem. Wear safety belt and use life line, Net etc.
4	Welding work at process plant including pipe lines , PG and acetylene plant	Only experienced people shall be allowed to carry out the work at height. Shall take care of nearby pipeline, remove all flammable materials. Get help from fire service.
5	Crane erection and modification work	Only experienced people shall be allowed to carry out the work. Wear safety belt and use life line. Net etc. Remove all loose material
6	Excavation and Blasting.	Some lapse is noticed obtaining Excavation permit, shall be strictly followed. Only licensed holder shall carry out blasting, accountability shall be properly maintained for the explosives, unauthorised/unapproved explosives shall not allowed. Only authorised equipment shall be used for blasting
7	Fragile roof work	Only experienced people shall be allowed to carry out the work at the fragile roof. Physically fit without any vertigo problem. Wear safety belt and use life line. Net etc. They shall be properly instructed before going to the roof.
8	Confined space work, cellars, furnace ducts	Oxygen level to be checked before work, proper breathing apparatus to be used. Only experienced people shall be allowed to carry out the work at cellars/confined space

10. Specified Speed limit 20 kmph to be followed by all the vehicles entered in factory premises.

11. Procedure given by user departments for spray painting, brush painting and dip painting should be followed. Paint sludge removal, empty tin removals etc. are to be periodically carried out and sent to disposal stores.

CONTRACTOR

143ACCEPTING OFFICER

BHEL-Trichy : Contractor Safety Guidelines

B. Electrical Contractors:

1. Must ensure proper care before working on electrical lines.
2. Must have obtained line clearance/ work permit for all electrical work, panel board cleaning, roof light changing, cable trench works and works in confined areas.
3. After completion of the work the line clearance/ permits must be closed.
4. Must remove all the left out choke, bulbs, tools, fasteners etc. after completion of the work (working on height).
5. Portable machines, lines drilling machines must be with proper plug points.
6. Unused new cables and fittings are to be returned to the concerned. Old cables/ used cables are to be removed and returned properly.

C. Painting Contractors:

1. Must know the characters of paints, thinners, solvents etc before handling.
2. User departments and the contractor must provide Materials Safety Data Sheets (MSDS) for the contract employees involved in painting work.
3. Contractors should provide respirators to the employees doing painting work.
4. User departments should ensure training for contract employees in Fire prevention, fire fighting etc.
5. The training shall be through Fire/Security department.
6. Contract employees must take adequate precaution to prevent fire while working.

D. Civil Contractors:

1. Employees working in Civil constructions should be familiar with the relevant work viz masonry work construction, tiles, partition, floor elevated work etc.
2. Tools, equipment pertaining to their works must be in good condition and with valid certificates. The workers employed must be skill ful enough to complete the work- roof work, work at height, excavation blasting etc.
3. Contractors must check the health of employees specific to occupation periodically and furnish evidence to welfare department/ BHEL. This is a must for the works like working at height, Jack hammering, sewage cleaning etc.
4. Vehicles used for construction works like lorries, excavation equipments (JCB), Mixing machines etc., are sound in operating condition.

BHEL-Trichy : Contractor Safety Guidelines

5. User departments should ensure that the applicable procedures are clearly understood by contract employees involved in civil maintenance viz flooring, floor cleaning, building maintenance, water line, pipe lines, storm water, ETP Maintenance etc. The adherence to the procedures must be ensured by contract supervisor.
6. The operators should be licensed, trained and authorized persons. Valid certificates/ documents must be shown on demand.
7. Employees should remove the waste materials from the work spot after completing the works.

E. Transport Contractors:

1. Vehicles carrying materials should have proper registration documents and must be produced on demand to BHEL security staff.
2. The driver of the vehicle must possess valid heavy duty license, vision Test certificates & relevant valid vehicle documents as per the factory Rules and to be produced on demand to the security staff.
3. The cleaner should be knowledgeable enough to give correct direction. Also should not drive inside or take training inside. Every vehicle should have pair of skilled driver and cleaner.
4. No persons other than driver should be allowed to sit or stand on the Prime Movers of the trailer.
5. Should not do Cooking, Bathing, Vehicle cleaning etc. within the premises.
6. The lights on right side (i.e.) over driver's cabin should be in working condition.
7. Both the head lights as well as park lamps must be in working condition.
8. The tire, brake, horn, turning lamps, etc must be in good conditions.
9. The vehicle should not be parked in the road in such a way to cause obstruction to vehicular traffic.
10. There must be a safe distance behind another moving truck.
11. If vehicle got break down, they should attend maintenance work and ensure to avoid oil and grease spillage & traffic issues.
12. Drivers should not do material handling activities.
13. Must not stand under/close to load while lifting the materials
14. Speed limit 20 km/hr to be maintained inside the factory premises.

BHEL-Trichy : Contractor Safety Guidelines

F. Shipping:

1. Strong side supports should be provided on both sides of the trailer. The side supports should be fixed in such a way that it cannot be removed even temporarily.
2. Adequate packing must be given for easy slinging operations. The packing materials should be good enough to withstand the load.
3. The stacking of loads on the truck should be evenly placed. The load should not be heaped together or dumped over the chassis.
4. The load on the truck should not be beyond its standard capacity. The carrying capacity must be clearly marked on the trailers also.
5. The loaded materials should be fastened tightly with wire rope. Coil rope should not at all be used.
6. There must be side packing such as gunny, rubber-tire between the sharp edges of the job and Wire rope in order to avoid cut in the wire rope.
7. There must be minimum two fastening and it should be more in case of lengthier loads.
8. The loose pieces should be bundled before loading on the truck.
9. There must be red flags or red lamps for the lengthy load which extend beyond chassis.
10. The materials should not be stacked too high to avoid hitting against live electric lines.
11. Must not lift beyond the capacity (SWL) of mobile cranes.
12. Must keep valid certificates for the individual (inclusive of vision Test certificates) and lifting equipment.
13. Should not use mobile cranes for transporting and dragging

VII Travels/Taxi Contractors:

1. Must have valid documents like Driving license, RC, Insurance, FC, Vision Test Certificate.
2. Max speed limit 20 KM/Hr must be followed, Timing prescribed for entry and exit to be strictly followed. Not to overtake inside the Premises.
3. Seat belt must be worn by taxi drivers, Park cars only in the permitted areas.
4. Using mobile phones while driving and playing iPod, inbuilt music systems etc in the vehicles. are banned within the factory premises.

BHEL-Trichy : Contractor Safety Guidelines

VIII Welfare:

1. The contractors are directed to generate PF number and ensure PF contribution remittance for all contract workmen engaged by them.
2. Bio-Metric Entry for Contract Workmen : Contractors have been directed to cover all the contract workmen engaged by them through Bio-Metric Entry System

XI Health Check up

Contractors must check the health of employees specific to occupation periodically and furnish evidence to welfare department/BHEL for updating. Specific test is a must apart from General Health checkup for the works like

1. Working at height- Vertigo test
2. Mobile crane operator- Vision test, audiometric test
3. Vehicle drivers- Vision test, audiometric test
4. Shot blasting operations- Lung function test, audiometric test
5. Canteen employees- Dermatitis
6. Jack hammering- Lung function test, audiometric test
7. Sewage cleaning- Lung function test,
8. Electro-plating- Skin and respiratory tract
9. Grinding - Lung function test, audiometric test
10. Spray painting - Skin and respiratory tract

X. Safety Equipment:

Contract employees must wear the PPEs relevant to the nature of work in addition to the safety shoes.

1. Welding - Welding Shield and goggles
2. Gas cutting - Aprons, Gas cutting goggles
3. Painting - PVC gloves, PVC apron, respirators
4. Electrical work - Electrical Resistance gloves, gum boots (during rain)
5. Work near hot furnace - Heat resistant gloves & Apron
6. Glass wool related works - Respirators, Barrier Cream
7. Slag removal, cleaning and grinding work - Goggles / dust respirators.
8. Handling of rough and sharp surfaced objects - Leather gloves
9. Sanitary work - Hand gloves, Gum boots
10. Concrete preparation - Gum boots Electrical
11. Work at height - Rubber gloves, Safety Belt, Fall arrestors, Life line Rope.

BHEL-Trichy : Contractor Safety Guidelines

XI. Violations:

The following will be treated as serious violations and appropriate actions are to be initiated by the users.

1. Employing people whose age is below 18 years.
2. Not wearing safety shoes or normal shoes (Contract employees will not be permitted after the security gates).
3. Not wearing PPEs.
4. Working without proper work permit.
5. Possession of mobile phones other than taxi drivers..
6. Using mobile phones while driving .
7. Unauthorized electrical connections .
8. Driving/operation of Crane/jumbo/Fork lift etc by unauthorized persons.
9. Unauthorized operation/driving of lorries, mobile cranes etc.
10. Smoking, alcohol, audio-playing etc.
11. Moving to unconnected areas.
12. Any willful act that creates unsafe conditions .

CIVIL ENGINEERING DEPARTMENT, BHEL, TRICHY-14

The contractor should engage Technical persons and Workmen with the following qualifications for works as detailed below and the contractor shall carry out the Health Performance check at his cost for the workman engaged in the work through a registered medical practitioner and produce the certificate on demand.

CHECK FOR HEALTH PERFORMANCE

Sl. No.	Activity	Hazard	Exposure Consequence	Check for	Periodicity
1	Concrete Dismantling	Emission of Dust & Noise	1	Lung function	Once in a Year
2	Concrete Mixing	Emission of Dust & Noise	1	Lung function	Once in a Year
3	Painting	Emission of Dust & fumes	1	Lung & throat function	Once in a Year
4	Cutting & Welding	Emission of fumes and gas. Exposure to Live wire	3	Eyes & Lung function	Once in a Year
5	Working on AC sheets	Emission of Dust	3	Lung function	Once in a Year
6	Sweeping of Roads	Emission of Dust	2	Lung function	Once in a Year
7	Collection and disposal of Sanitary waste	Foul smell & susceptibility to disease.	3	Lung function and skin irritation	Once in a Year
8	Handling of Oxygen & Acetylene Cylinders	Leakage of gas	4	Throat irritation	Once in a Year
9	Cleaning of Manholes	Exposure to poisonous gas	4	Suffocation	Once in a Year
10	Cleaning of Overhead tank	Emission of Dust	1	Suffocation & skin irritation	Once in a Year

NOTE: Exposure Consequence

- 1.Slightly harmful
2. Harmful
- 3.Very harmful

CONTRACTOR

149ACCEPTING OFFICER

SCHEDULE 'A'

LIST OF WORKS AND PRICES

DETAILS & QUANTITIES of each item of work shown in the BILL OF QUANTITIES are only approximate. They are given as a guide for the purpose of tendering only and are liable to variation and alteration of the Competent Authority. The work under each item as executed shall be measured and priced at the corresponding rate quoted by the contractor in the BILL OF QUANTITIES

Sl.No.	Description of work / supplied	Total amount of work / supplies (in figures and words)		Period of contract
		Rs.	Ps.	
1.	ROAD, WATER SUPPLY & PLUMBING, HORTICULTURE, STRUCTURAL STEEL WORKS AT BHEL TOWNSHIP-TRICHY	Rs 212 Lakhs/-		12 (Twelve) MONTHS
		(For all the Four Packages together)		

BILL OF QUANTITIES

Sl. No.	Appx. Qty.	Description of work	TNBP No.	Rate (Both in Unit fig & Words)	Amount	
					Rs.	Ps.

AS PER SEPARATE SHEETS ATTACHED SHEETS IN PRICE BID

CONTRACTOR

150 ACCEPTING OFFICER

CIVIL ENGINEERING DEPARTMENT, BHEL, TRICHY-14
'SCHEDULE B'

1. The following materials will be issued FREE of cost to contractor at BHEL Stores / Stock yard if specified in the BOQ and specifications.

SI.No.	DESCRIPTION	PLACE OF ISSUE
1	Cement	BHEL STORES or Stock yard
2	M.S Rounds, C.T.D Bars & Structural Steel	BHEL STORES or Stock yard

2. It will be the responsibility of the Contractor to submit his demands for the above stores in writing atleast seven days in advance of the actual requirement.
3. Issue of Stores is subject of the availability at the place of issue cited above, items of stores to be issued by BHEL which are not available at the time of indenting by the contractor may be supplied by BHEL after necessary procurement. The contractor shall not be entitled to any claim of compensation for delay in the supply of stores by BHEL under any circumstances.
4. The materials will be issued only during the working hours of the BHEL Stores Department (8.00 a.m. to 4.30 p.m.). Contractor shall have to transport them to the site of work at his own cost as soon as they are issued to him.
5. The steel materials if issued will be in random lengths and sizes as stocked by the BHEL and the cost of all cutting, conversion, substitution and fabrication as well as wastage shall have to be borne by the Contractor.
6. The contractor shall from time to time render proper account of all materials issued to him by BHEL. If he fails to do so, no further issue of materials will be made to him and he will be held responsible for any delay in the execution of the work which may occur on this account.
7. Where A.C. Sheets and accessories, Doors, Windows, Sanitary fittings, Special glasses or other items are issued free of cost to the contractor, the contractor will have to make good at his own cost any loss or damage to any part or whole of the items issued to him as above. All wastage within the premises limits as fixed by BHEL will be charged for at the prescribed issued rates of BHEL. Excess wastage will be charged for at punitive rates which will be 100% higher than the issue rates.
8. All surplus materials in good condition which are not returned to the BHEL Stores as also quantities of materials consumed in excess of the max. permissible limit as fixed by BHEL shall be charged for at punitive rates.

The decision of the Senior Engineer / Dy. Manager / Manager as to the extent to which materials have been rendered surplus or consumed in excess of the actual requirements shall be final and conclusive and binding on the contractor.

CONTRACTOR

151

ACCEPTING OFFICER

SCHEDULE 'C'

ISSUE OF TOOLS AND PLANTS TO CONTRACTORS

Sl.No.	Qty.	Particulars	Details of BHEL Crew Supplied	Hire Charges Per unit Per Day	Place of Issue	Remarks
.....Nil.....						

a. Machineries shall not be operated over time without the written permission of the Sr. Engineer / Dy. Manager / Manager.

b. All Coolies, Watermen etc., required in addition to BHEL crew mentioned in column 4 above shall be arranged by the contractor at his own expense.

SCHEDULE 'D'

NOTE : All Drawings are to be signed by the Contractor as well as the officer entering into contract.

SL.No.	DRAWING NUMBER	DESCRIPTION
1	NIL	

SCHEDULE 'E'

LEAD STATEMENT

SI.No.	Name of Material	Name of Source	Lead Particulars both for Factory and Township
1	Cement	BHEL STORES or Stock yard	2 Kilometre
2	M.S Rounds, C.T.D Bars & Structural Steel	BHEL STORES or Stock yard	2 Kilometre

CIVIL ENGINEERING DEPARTMENT,BHEL,TRICHY-14

C.A

C.A.....Date

.....
(To be used in conjunction with BHE Ltd., General Conditions of Contract)

AUTHORITY TO TENDER

Tender Notice No.CT:TN: **03/18-19**

Office of the

**SMCIVIL/PLANNING,Design & QC
BHARAT HEAVY ELECTRICALS LIMITED
TIRUCHY – 14.**

Tender Schedule No.CT:TS: **12/18-19**

CT:TS:13/18-19

CT:TS:14/18-19

CT:TS:15/18-19

~~Lumpsum~~ /Percentage rate/ Item rate tender for works required in **“ROAD,WATER
SUPPLY &PLUMBING, HORTICULTURE, STRUCTURAL STEEL WORKS AT BHEL
TOWNSHIP-TRICHY”**

Messrs. ‘are / is
hereby authorized to tender for the above work. The Tender is to be delivered at the Office of
the **SMCIVIL/PLANNING,Design & QC ,53 Building Ground floor** Bharat Heavy Electricals
Limited, Thiruverumbur, Tiruchirappalli – 620 014, **up to 10.00 hrs. on 15.05.2018**
addressed to the **SMCIVIL/PLANNING,Design & QC,Building No.53 Ground floor**, BHEL.
Tiruverumbur, Tiruchirapalli – 620 014 superscribing the name of work as mentioned above.

Any correspondence concerning this Tender should be addressed as indicated above quoting
the Tender Notice, schedule No. and other relevant particulars.

BHARAT HEAVY ELECTRICALS LIMITED DO NOT BIND THEMSELVES TO ACCEPT THE
LOWEST OR ANY TENDER

**Issuing Officer with
Designation**

CONTRACTOR

153

ACCEPTING OFFICER

Contract Agreement No.....

TENDER

To

SMCIVIL/PLANNING, Design & QC
Bharat Heavy Electricals Limited
Unit : Tiruverumbur
TIRUCHIRAPPALLI – 620 014.

I / We hereby offer to carry out the work of “**ROAD, WATER SUPPLY & PLUMBING, HORTICULTURE, STRUCTURAL STEEL WORKS AT BHEL TOWNSHIP-TRICHY**”

I / We hereby carefully perused the following documents connected with the above noted work and agree to abide the same.

1. Specifications (General & Particular)
- ~~2. Drawings~~
3. Schedule ‘A’, ‘B’, ‘C’, ‘D’ & ‘E’ and Bill of Quantities attached hereto.
4. Schedule or rates
5. BHE Ltd., General & Special Conditions of Contract, Tender Notice and Instructions to Tenders attached hereto.

I / We forward herewith the sum of Rs.....as Earnest Money, which shall be refunded should this tender be rejected. I / We further agree to deposit such sum which along with the sum of Rs.....mentioned above shall make up 50% of the fully Security Deposit for this work as provided for under conditions of the BHARAT HEAVY ELECTRICALS LIMITED General Conditions of Contract.

I / We further agree to execute all the work referred to in the said documents upon the terms & condition contained or referred therein and as detailed in Schedule ‘A’ and Bill of Quantities annexure thereto an to carry out such deviations as may be ordered, vide conditions 6 of the BHEL Ltd., General Conditions of Contract upto a maximum of 20% of the tendered of Rs.....

I / WE further agree to refer all disputes, as required by condition 62 of the General conditions of Contract to the sole arbitration of an Officer, to be appointed by the General Manager, B.H.E. Ltd., in his sold discretion whose decision shall be final and binding.

WITNESS

Signature of the Contractor

Date :

1.

2.

GENERAL SUMMARY

- 1. (a) Net Cost of works or building etc., from Schedule 'A' and Bill of quantities annexed thereto Rs.
- 2. Provisional sum Rs.

Total
Rs.

Rupees.....

..... Shri.....

..... in the capacity of
..... has been duly authorized by me / use to
sign the tender for and on behalf of

.....
..... (in block letters)

Date : SIGNATURE OF CONTRACTOR

Witness : Postal Address :

1..... Telephone No.
Address

2.
Address

..... alternations have been made in the Tender Document and as evidence that these alternations were made before the execution of contract agreement, they have been initialed by the Contractor and the

..... is hereby authorized to sign and initial on my behalf the documents forming part of this contract (Number of alternation in figures and words to be given me)

The above tender is accepted by me on behalf of the Bharat Heavy Electricals Limited, Unit Thriuverumbur, Tiruchirappalli – 620 014. for a sum of Rs..

..... at the item rates as indicated in the Bill of Quantities attached to Schedule 'A'.

Signature Date.....

Designation

E FORMAT

THE PURCHASE/CONTRACT EXECUTING AGENCY/BHEL

ACCEPTANCE FOR ELECTRONIC FUND TRANSFER / RTGS TRANSFER

01	Name & Address of the Supplier / Sub-contractor																					
02	VENDOR CODE assigned by BHEL																					
	Details of Bank Account:																					
03	NAME & ADDRESS OF THE BANK																					
04	NAME OF THE BRANCH																					
05	BRANCH CODE																					
06	MICR CODE	<table border="1" style="display: inline-table; border-collapse: collapse;"> <tr> <td style="width: 20px; height: 20px;"></td> <td style="width: 20px; height: 20px;"></td> <td style="width: 20px; height: 20px;"></td> <td style="width: 20px; height: 20px;"></td> <td style="width: 20px; height: 20px;"></td> <td style="width: 20px; height: 20px;"></td> <td style="width: 20px; height: 20px;"></td> <td style="width: 20px; height: 20px;"></td> <td style="width: 20px; height: 20px;"></td> <td style="width: 20px; height: 20px;"></td> <td style="width: 20px; height: 20px;"></td> <td style="width: 20px; height: 20px;"></td> <td style="width: 20px; height: 20px;"></td> <td style="width: 20px; height: 20px;"></td> <td style="width: 20px; height: 20px;"></td> <td style="width: 20px; height: 20px;"></td> <td style="width: 20px; height: 20px;"></td> <td style="width: 20px; height: 20px;"></td> <td style="width: 20px; height: 20px;"></td> <td style="width: 20px; height: 20px;"></td> </tr> </table>																				
07	ACCOUNT NUMBER																					
08	TYPE OF ACCOUNT	CURRENT A/C / OD / CASH CREDIT																				
09	BENEFICIERY'S NAME																					
10	IFSC CODE OF THE BRANCH	<table border="1" style="display: inline-table; border-collapse: collapse;"> <tr> <td style="width: 20px; height: 20px;"></td> <td style="width: 20px; height: 20px;"></td> <td style="width: 20px; height: 20px;"></td> <td style="width: 20px; height: 20px;"></td> <td style="width: 20px; height: 20px;"></td> <td style="width: 20px; height: 20px;"></td> <td style="width: 20px; height: 20px;"></td> <td style="width: 20px; height: 20px;"></td> <td style="width: 20px; height: 20px;"></td> <td style="width: 20px; height: 20px;"></td> <td style="width: 20px; height: 20px;"></td> <td style="width: 20px; height: 20px;"></td> <td style="width: 20px; height: 20px;"></td> <td style="width: 20px; height: 20px;"></td> <td style="width: 20px; height: 20px;"></td> <td style="width: 20px; height: 20px;"></td> <td style="width: 20px; height: 20px;"></td> <td style="width: 20px; height: 20px;"></td> <td style="width: 20px; height: 20px;"></td> <td style="width: 20px; height: 20px;"></td> </tr> </table>																				
11	EMAIL ID																					
12	TELEPHONE/MOBILE NO.																					

CERTIFICATE

I / We hereby agree to receive the payments due from BHARAT HEAVY ELECTRICALS LIMITED by the National Electronic Funds Transfer and/or RTGS Transfer mode by credit to my / our above mentioned Bank Account. I / We also agree that payments made to the above mentioned Account is a valid discharge of the liability of Bharat Heavy Electricals Limited. I / We also agree to bear the applicable Bank Charges for the above mode of transfer. **A copy of the cheque leaf/cancelled cheque leaf of the above account is sent herewith.**

AUTHORISED SIGNATORY WITH NAME SEAL

Banker's Certification

We confirm that we are enabled for receiving RTGS and NEFT credits and we _____ further confirm that the account number of _____ (name of account holder), the signature of the authorized signatory and the MICR and IFSC codes of our Branch mentioned above are correct.

PLACE: _____ (Manager / Officer's)
 DATE : _____ Signature Under Bank stamp and Name Seal
 With Membership No. _____
 (Telephone / Mobile No. _____)

Forwarded to Accounts Dept.
 We confirm the above details are verified with the records available with us.
 Signature of the BHEL Executive with Name Seal (Operating the Contract/Services)

SIGNATURE OF THE APPLICANT