

1820369/2023/PS-PEM-EL

1 X 800 MW KOTHAGUDEM TPS STAGE-VII, UNIT#12 (FGD PKG)							
BOQ-CUM-PRICE SCHEDULE FOR 220V DC LEAD ACID BATTERIES							
SL NO	ITEM CODE	ITEM DESCRIPTION/ SERVICE	UOM	QTY	UNIT PRICE	TOTAL PRICE	REMARKS
1	508-11013-A	BREAK UP DETAIL for LEAD ACID PLANTE 220V BATTERY 1					
1.01		220V DC, Lead-Acid plante High discharge type battery as per Annexure-II (Load duty cycle) of Section-I, 1.80 ECV, 108 cells, with all accessories listed under clause 2 below	Sets	2			
1.02		Electrolyte (sulphuric acid for first filling plus 10% extra in non-returnable container)	Sets	2			
1.03		FRP rack properly treated with three coats of anti-acid paints for acid resistance for 220V battery bank	Sets	2			
1.04		Insulator, rubber pad etc. for rack (with 5% extra)	Lot	2			
1.05		Inter cell, Inter row and Inter bank connectors with connection hardware as required for complete installation plus 5% extra and end take off with one no. extra take off.	Lot	2			
1.06		Teakwood Cable clamps with hardware/ cable supporting arrangement having L Type copper connectors	Lot	2			
2		LIST OF ACCESSORIES					
2.01		Hydrometer (in step of 0.005)	Nos	2			
2.02		Set of hydrometer syringes (suitable for the vent holes in different cells for specific gravity reading)	Nos	2			
2.03		Bridging clamps	Sets	4			
2.04		Battery log book	Nos	2			
2.05		Instruction card	Nos	4			
2.06		Specific gravity correction chart	Nos	4			
2.07		Thermometer (0 to 100 deg.C) with plug and cap	Nos	4			
2.08		Digital cell testing voltmeter (3-0-3 V) with testing leads	Nos	4			
2.09		Pocket Thermometer (Digital type)	Nos	6			
2.10		Electrolyte resistant plastic funnels	Nos	4			
2.11		Electrolyte resistant plastic jug	Nos	4			
2.12		Plastic filling bottles for filling up	Nos	4			
2.13		Rubber apron	Nos	4			
2.14		Rubber hand gloves	Pair	4			
2.15		Cell lifting straps	Sets	4			
2.16		Insulated Spanner for cells	Nos	4			
2.17		Self adhesive PVC stickers for cell numberings	Sets	4			
2.18		Goggles (Industrial)	Nos	4			
2.19		'No smoking' notice	Nos	4			
2.2		Wall mounting holders for hydrometer and thermometer	Nos	4			
2.21		Battery Trolley with Nylon wheels	Nos	2			
2.22		Hot air gun	Nos	2			
2.23		Siphons	Sets	2			
3	508-11007-A	E&C SPARES					
3.01		Rubber hand gloves	Pair	2			
3.02		Vent Plugs	Nos	5			
3.03		Intercell connectors	Nos	5			
4	508-11000-B	MANDATORY SPARES					
4.01		Complete dry cell	Nos	6			
4.02		Intercell connectors with hardware (1 Lot = 10% or 5 nos. whichever is more for total population of 2 sets of battery)	Lot	1			
4.03		Vent Plug (1 Lot = 10% or 5 nos. whichever is more for total population of 2 sets of battery)	Lot	1			
4.04		Stand Insulator (1 Lot = 20% or 10 nos. whichever is more for total population of 2 sets of battery)	Lot	1			
5	508-11025-A	SUPERVISION OF E&C (INCLUDING SUPERVISION OF CAPACITY TEST CONDUCTION AT SITE PRIOR TO PUTTING BATTERY IN SERVICE)					
5.01		LUMP SUM CHARGES PER VISIT FOR ENGINEER (EXCEPT DAILY CHARGES)	VISIT	2			Refer Note-1 & 2
5.02		LUMP SUM DAILY CHARGES FOR ENGINEER	DAYS	10			Refer Note-1 & 2
5.03		SUPERVISION OF TYPE TEST : CAPACITY TEST AND TEST FOR VOLTAGE ON BATTERY DURING DISCHARGE (TO BE CARRIED OUT AT SITE ON COMPLETION OF E&C AND IMMEDIATELY PRIOR TO PUTTING BATTERY IN SERVICE)	DAYS	10			Refer Note-3
6	508-11029-A	TYPE TESTS					
6.01		Test for retention of charge	Lot	1			
6.02		Endurance test	Lot	1			
6.03		Ampere hour & watt hour efficiency test	Lot	1			
6.04		Capacity test and test for voltage on battery during discharge	Lot	1			
Notes:-							
1. AMOUNT PAYABLE FOR ENGINEER PER VISIT TO SITE = VISIT CHARGES AS PER SL. NO.5.01 ABOVE + (DAILY CHARGES AS PER SL. NO. 5.02 ABOVE) X NO. OF DAYS AT SITE) (TO BE CERTIFIED BY BHEL SITE).							
2. THE VISIT CHARGES SHALL BE INCLUSIVE OF CHARGES OF AIR FARE/ TRAIN FARE/ VISA FEES, BOARDING/ LODGING, LOCAL CONVEYANCE, MEDICAL, INSURANCE ETC.							
3. THE CHARGES FOR SUPERVISION OF E & C AT SL.NO.5 ABOVE, INCLUDE SUPERVISION OF CONDUCTION OF CAPACITY TEST AT SITE PRIOR TO COMMISSIONING OF BATTERY. VENDOR TO MENTION CHARGES FOR THE SAME SEPARATELY AT ROW 5.03-RELEVANT COLUMN.							
4. COPPER LUGS FOR CABLE TERMINATION AT BATTERY TERMINALS SHALL BE IN BIDDER'S SCOPE & CABLE SIZES SHALL BE INFORMED DURING DETAILED ENGINEERING.							

Rahul Kumar Shrivastava
 Digitally signed by Rahul Kumar Shrivastava
 DN: cn=Rahul Kumar Shrivastava, o=BHEL, ou=PEM, email=Rkshrivastava@bhel.in, c=IN
 Date: 2023.12.07 17:12:50 +05'30'

1820369/2023/PS-PEM-EL

	1 X 800 MW KOTHAGUDEM TPS STAGE-VII,	PE-PQ-439-508-E005
	UNIT#12 (FGD PACKAGE)	REVISION NO. 00 DATE 14/11/2022
	PRE-QUALIFICATION REQUIRMENTS FOR DC LEAD ACID BATTERIES	SHEET NO. 1 OF 1



ITEMS & TYPE OF BATTERY: 220V/110V DC Lead acid (Plante) battery of rating 150AH & above

SCOPE: Supply : YES; Erection & Commissioning : NO; Supervision of Erection & Commissioning : YES;

1	Vendor should be designer & manufacturer of the applicable type of Battery.
2	Vendor to furnish published technical catalogue for the applicable type of batteries.
3	Availability of type test certificates conducted at independent Lab or witnessed by third party as per IS/International standards for the applicable type of batteries.
4	In-house capability to carry out all routine and acceptance tests as per IS/International standards for the applicable type of batteries.
5	Vendor should have manufactured and supplied at least two (2) numbers of highest offered rating or above of high discharge type Plante positive plate type battery at least one (1) each at two (2) different industrial installations, which should be in successful operation for at least two (2) years as on 20/07/2017. Performance certificate should be from end user only. Note : Two different installations means two different project sites or two different contracts.
6	Minimum two (2) nos. purchase orders for the applicable type of batteries shall be submitted which should not be more than five (5) years old from the date of techno- commercial bid opening (as applicable) for establishing continuity in business.

Notes (General points):

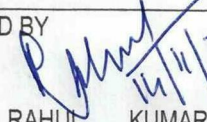
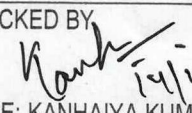
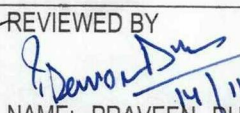
1. Consideration of offer shall be subject to customer's approval of bidders, if applicable.
2. Bidder to submit all supporting documents in English. If documents submitted by bidder are in language other than English, a self-attested English translated document should also be submitted.
3. Notwithstanding anything stated above, BHEL reserves the right to assess the capabilities and capacity of the bidder to perform the contract, should the circumstances warrant such assessment in the overall interest of BHEL.
4. After satisfactory fulfillment of all the above criteria/ requirement, offer shall be considered for further evaluation as per NIT and all the other terms of the tender.
5. PQR Clause No. 5 above is in-line with end customer proven make criteria.

PREPARED BY  NAME: RAHUL KUMAR SHRIVASTAVA, MANAGER(E)	CHECKED BY  NAME: KANHAIYA KUMAR, SR MANAGER(E)	REVIEWED BY  NAME: PRAVEEN DUTTA, AGM(E)	APPROVED BY  NAME: DEBASISA RATH, AGM & CH(E)
---	---	---	---

TELANGANA STATE POWER GENERATION CORPORATION LIMITED

1 X 800 MW KOTHAGUDEM TPS STAGE-VII, UNIT#12 (FGD PKG)

VOLUME – II

TECHNICAL SPECIFICATION FOR
220V DC Lead Acid Plante Battery

BHEL DOCUMENT NO. : PE-TS-439-508-E001
REVISION NO. : 0



BHARAT HEAVY ELECTRICALS LIMITED
POWER SECTOR
PROJECT ENGINEERING MANAGEMENT
NOIDA-201301, UTTAR PRADESH, INDIA



**TECHNICAL SPECIFICATION FOR
220V DC Lead Acid Plante Battery**

SPECIFICATION NO. PE-TS-439-508-E001

VOLUME II

REVISION 0 | DATE: 24.11.23

SHEET 1 OF 1

CONTENTS

<u>S. NO.</u>	<u>CONTENTS</u>	<u>NO. OF SHEETS</u>
1)	COMPLIANCE CERTIFICATE	01
2)	SECTION – I	
a)	SPECIFIC TECHNICAL REQUIREMENTS	04
b)	DATA SHEET-A	01
c)	DATA SHEET-C	03
d)	ANNEXURE-I (SINGLE LINE DIAGRAM FOR 220V DC SYSTEM)	01
e)	ANNEXURE-II (LOAD DUTY CYCLE)	01
f)	ANNEXURE-III (DOCUMENTS REQUIRED ALONG WITH TECHNICAL OFFER)	01
g)	ANNEXURE-IV (DRAWING/ DOCUMENTS SCHEDULE)	01
3)	SECTION – II	
a)	STANDARD TECHNICAL REQUIREMENTS	07
b)	QUALITY PLAN	04

TOTAL NO. OF SHEETS = 26 (INCLUDING COVER/ SEPARATOR SHEETS)



**TECHNICAL SPECIFICATION
FOR 220V DC Lead Acid Plants
Battery**

SPECIFICATION NO. PE-TS-439-508-E001

VOLUME II

REVISION 0

DATE: 24.11.23

SHEET 1 of 1

COMPLIANCE CERTIFICATE

The bidder shall confirm compliance to the following by signing/ stamping this compliance certificate and furnishing same with the offer.

1. The scope of supply, technical details, construction features, design parameters etc. shall be as per technical specification & there are no exclusion/ deviation with regard to same.
2. There is no deviation with respect to specification.
3. Only those technical submittals which are specifically asked for in NIT to be submitted at tender stage shall be considered as part of offer. Any other submission, even if made, shall not be considered as part of offer.
4. Any comments/ clarifications on technical/ inspection requirements furnished as part of bidder's covering letter shall not be considered by BHEL, and bidder's offer shall be construed to be in conformance with the specification.
5. Any changes made by the bidder in the price schedule with respect to the description/ quantities from those given in BOQ-Cum-Price schedule enclosed with NIT shall not be considered (i.e., technical description & quantities as per specification shall prevail).

BIDDER'S STAMP & SIGNATURE

	TECHNICAL SPECIFICATION FOR 220V DC Lead Acid Plante Battery	SPECIFICATION NO. PE-TS-439-508-E001	
		VOLUME II	
		SECTION I	
		REVISION 0	DATE: 24.11.23
		SHEET 1 OF 4	

SECTION –I
SPECIFIC TECHNICAL REQUIREMENTS

	TECHNICAL SPECIFICATION FOR 220V DC Lead Acid Plante Battery	SPECIFICATION NO. PE-TS-439-508-E001	
		VOLUME II	
		SECTION I	
		REVISION 0	DATE: 24.11.23
		SHEET 2 OF 4	

1.0 SCOPE OF ENQUIRY

- 1.1 This specification covers the design, manufacture, inspection and testing at manufacturer's works, proper packing, delivery to site and supervision of E&C of 220V DC BATTERY as mentioned in different sections of this specification.
- 1.2 Standard technical requirements of the 220V DC BATTERY are indicated in Section-II. Project specific technical/ quality requirements / changes are listed in Section-I & Data Sheet-A.
- 1.3 The stipulations of Section-I, followed by those of Data Sheet-A shall prevail in case of any conflict between the stipulations of Section-I, Datasheet-A & Section-II.

2.0 BILL OF QUANTITIES:

- 2.1 Quantity requirements shall be as per **BOQ cum Unpriced Price Schedule** enclosed with NIT.

3.0 SPECIFIC TECHNICAL REQUIREMENTS:

- 3.1 Technical /Quality/ Inspection:

S. No.	Reference clause No. of Section II (if any)	Specific Requirement/ Change
1	Section-II, Clause no. 13.0	Refer Annexure-III of Section-I.
2	Section-II, Clause no. 9.2): INSPECTIONS & TESTING	<p>In continuation to clause no. 9.2, following shall be added:</p> <p>(a) Following type tests of the battery to be conducted as per IS-1652:</p> <ul style="list-style-type: none"> (i) Test for retention of charge (ii) Endurance test. (iii) Ampere hour & watt hour efficiency test (iv) Capacity test and test for voltage on battery during discharge <p>The charges of the above type tests shall be given separately in price schedule as indicated in BOQ-CUM PRICE SCHEDULE enclosed with NIT.</p> <p>(b) Type Test on Container: Following type test on two cells of the battery to be conducted.</p> <ul style="list-style-type: none"> (i) Container shall be type tested as per IS:1146 <p>(c) Bidder shall also submit the valid type test reports for all the type tests listed under Annexure-A of Quality plan as per relevant standards on identical equipment in type and rating. In absence of valid type tests reports, vendor shall conduct all such type tests without any commercial/delivery implication to BHEL.</p> <p>(d) Supervision for <i>Capacity test and test for voltage on battery during discharge</i> shall be carried out at site on completion of E&C and</p>

	TECHNICAL SPECIFICATION FOR 220V DC Lead Acid Plante Battery	SPECIFICATION NO. PE-TS-439-508-E001	
		VOLUME II	
		SECTION I	
		REVISION 0	DATE: 24.11.23
		SHEET 3 OF 4	

		<p>immediately prior to putting battery in service. Necessary equipment, including the discharge resistor, charger, tools, tackles and instruments shall be arranged by BHEL. Above test shall be supervised by bidder during the visit for supervision of E&C as indicated in BOQ-CUM PRICE SCHEDULE enclosed with NIT.</p>
--	--	--

3.2 Construction:

1. Cell container shall be made of transparent glass, hard rubber, suitable robust, heat resistant, leak proof, non-absorbent, acid resistant, non-bulging type and free from flaws, such as wrinkles, cracks, blisters, pin holes, etc. The cell shall be mechanically sturdy. Container shall be closed/sealed lid type. Lid and sealing compound shall be non-cracking type. The pole sealing arrangement shall be such that no acid particle gets entrapped due to acid creep as a result of capillary action and it shall be possible to remove and refit the sealing to carry out maintenance.
2. The cell shall be provided with visual electrolyte level checks for ease in of maintenance. Electrolyte level markings shall be for upper and lower limits.
3. Sufficient sediment space shall be provided so that the cells will not have to be cleaned out during normal life.
4. Separator between plates shall permit free flow of electrolyte. Proper arrangement to keep end plates in position shall be furnished.
5. For flooded cell, suitable mechanism and / or Ceramic Vent plug shall be provided to eliminate emission of acid mist during the float operation. The bidder shall also indicate the Gas emission rate of the battery in their offer for necessary design of the ventilation of the Battery Room. Anti-splash type vent plug shall be provided in each cell.
6. The cell terminals posts shall be provided with connector bolts and nuts made of copper/ brass effectively coated with lead to prevent corrosion.
7. Lead coated copper connectors shall be furnished to connect up cells of Battery set.
8. Positive and Negative terminal posts shall be clearly and indelibly marked for easy identification.
9. Bent copper plates, tubular copper lugs, teakwood clamp, bolts, nuts, washers, etc. shall be furnished for connection of outgoing cables to end take-off connections at positive and negative plate. All connectors and lugs shall be capable of continuously carrying the discharge current of the battery for the entire load cycle and let though fault current which the battery can produce and withstand for the period declared.

	TECHNICAL SPECIFICATION FOR 220V DC Lead Acid Plante Battery	SPECIFICATION NO. PE-TS-439-508-E001	
		VOLUME II	
		SECTION I	
		REVISION 0	DATE: 24.11.23
		SHEET 4 OF 4	

10. **Battery racks** for supporting battery cells shall be constructed of best quality FRP forming a rigid structure. Racks shall be painted with at least three (3) coats of electrolyte-resistant paint of approved shade. Racks shall be free standing type, mounted on porcelain / electrolyte-resistant high impact plastic insulators. Numbering tags for each cell shall be attached on to the racks.

4.0 SINGE LINE DIAGRAM FOR 220V DC SYSTEM

(Refer Annexure-I enclosed with Section-I)

5.0 LOAD DUTY CYCLE

(Refer Annexure-II enclosed with Section-I)

6.0 DOCUMENTS REQUIRED ALONG WITH TECHNICAL OFFER

(Refer Annexure-III enclosed with Section-I).

7.0 DRAWING/DOCUMENTS REQUIRED AFTER AWARD OF CONTRACT

(Refer Annexure-IV enclosed with Section-I).

**TECHNICAL SPECIFICATION FOR
220V DC Lead Acid Plante Battery**

SPECIFICATION NO. PE-TS-439-508-E001

VOLUME II

SECTION I

REVISION 0 | DATE: 24.11.23

SHEET 1 OF 1

DATA SHEET-A

1	Rated voltage (V)	:	220V DC
2	Type of Battery	:	High Discharge Lead-Acid Plante
3	Conforming to	:	IEEE/IEC/ IS standards
4	DC system Fault level & duration	:	25KA for 1 Sec (Maximum)
5	DC System Earthing	:	Unearthed
6	Material of Battery Rack	:	FRP rack properly treated with three coats of anti-acid paints for acid resistance for 220V battery bank
7	Design Ambient Temperature	:	50 Deg. C
8	Minimum Electrolyte Temperature to be considered for Battery Sizing	:	7.9 Deg. C
9	No. of cells	:	108
10	End cell voltage	:	1.80 V/cell
11	Nominal Float voltage (V)	:	2.25 V/cell
12	Boost voltage (Maximum) (V)	:	Bidder to furnish the detail along with offer
13	AH Capacity of battery (As per "Annexure-II: Load duty cycle" enclosed with Specification)	:	Bidder to furnish quoted AH capacity and battery sizing calculation along with offer (Minimum Battery Rating 400AH)
14	Arrangement of batteries on racks	:	Single tier for batteries having cell weight 50kg or more
15	Cable size to be terminated at Battery end (Tentative size) <i>Final size shall be informed during detailed engineering. Battery terminal shall be made suitable.</i>	:	2 RUNS OF 1C x 400 sq.mm (Cu) FS CABLE/ pole
16	Tapping to be provided in battery	:	To be decided during detailed engineering
17	Tapping to be provided at which cell (if Tapping is applicable)	:	To be decided during detailed engineering
18	Type of cable lugs to be supplied <i>(Suitable number of copper lugs for cable termination at battery terminals shall be provided by bidder. Tentative cable size has been informed at Sl. No. 15 above. Final cable size shall be informed during detailed engineering)</i>	:	Copper tubular lugs
19	Recommended boost charging rate <i>(battery to be charged in 10 hrs)</i>	:	Bidder to furnish the detail along with offer
20	Recommended trickle charging rate	:	Bidder to furnish the detail along with offer

Notes:

- 1) Bidders stand guarantee that the rating offered at S. No. 13 shall meet 'Load Duty Cycle' as per Annexure – II of specification.

1820369/2023/PS-PEM-EL

**TECHNICAL SPECIFICATION FOR
220V DC Lead Acid Battery**

SPECIFICATION NO. PE-TS-439-508-E001

VOLUME II

SECTION I

REVISION 0 | DATE: 24.11.23

SHEET 1 OF 3

DATA SHEET-C

DATASHEET-C



**TECHNICAL SPECIFICATION FOR
220V DC Lead Acid Battery**

SPECIFICATION NO. PE-TS-439-508-E001

VOLUME II

SECTION I

REVISION 0 | DATE: 24.11.23

SHEET 2 OF 3

DATA SHEET-C

S. No.	PARAMETER	UNIT	VALUE
1.0	Make and Type		
2.0	AH capacity at 27° C and end voltage		
2.1	At 10 Hr discharge rate	AH	
2.2	At 1 Hr discharge rate	AH	
3.0	Battery Discharge current		
3.1	At one minute rate	Amp	
3.2	At 30 minutes rate	Amp	
3.3	At 30 minutes rate at end voltage	Amp	
3.4	At 60 minutes rate	Amp	
3.5	At 60 minutes rate at end voltage	Amp	
3.6	At 120 minutes rate at end voltage	Amp	
4.0	Types of plates		
4.1	Negative plates		
4.2	Positive plates		
5.0	Method of connection between cells		
6.0	Voltage per cell at the end of charge at the finishing rate	V	
7.0	Recommended Trickle charge current	Amp	
8.0	Type and material of separators		
9.0	Material of container		
10.0	Type of container		
11.0	Internal resistance of cells	Ohms	
12.0	Total resistance of connectors	Ohms	
13.0	Insulator Material for		
13.1	Cells		
13.2	Racks		
14.0	Average life	Years	
15.0	Recommended boost charger rating for		
15.1	Charging in 8 hours	Amp	
15.2	Charging in 10 hours	Amp	
16.0	Allowable ripple content acceptable to battery (r.m.s)	%	

1820369/2023/PS-PEM-EL

**TECHNICAL SPECIFICATION FOR
220V DC Lead Acid Battery**

SPECIFICATION NO. PE-TS-439-508-E001

VOLUME II

SECTION I

REVISION 0 | DATE: 24.11.23

SHEET 3 OF 3

DATA SHEET-C

17.0	Hydrogen evaluation		
18.0	Cell designation in accordance with IS: 1651/1652		
19.0	Applicable standard		
20.0	Whether battery performance curve and calculation for capacities enclosed		
21.0	Recommended Maximum period of storage of Electrolyte before first charge		
22.0	Amount and specific gravity of electrolyte per cell required for first filling at 27° C		
23.0	Recommended specific gravity of electrolyte at 27° C		
23.1	When fully charged		
23.2	When fully discharged		
24.0	Container dimensions	(L X B X H) mm	
25.0	Distance between centres of cells when erected	Mm	
26.0	Terminal connectors		
26.1	Type		
26.2	Material		
27.0	Battery Racks		
27.1	Type & Material		
27.2	Outline dimensions	(L X B X H) mm	
27.3	Net weight	Kg	
28.0	Weight per cell	Kg	
28.1	Net dry weight	Kg	
28.2	Net weight with electrolyte	Kg	
29.0	Total shipping weight of one battery unit (without electrolyte)	Kg	
30.0	Taps provided at cell no.		
31.0	Connection from battery to charger (busbar/ cable)		
32.0	Recommended size of (busbar/ cable)		
33.0	Whether backup calculation furnished		
34.0	Cable lugs at battery terminals of suitable size		

Note: Indicates data / documents to be furnished after the award of Contract.



TECHNICAL SPECIFICATION FOR 220V DC Lead Acid Plante Battery

SPECIFICATION NO. PE-TS-439-508-E001

VOLUME II

SECTION I

REVISION 0

DATE: 24.11.23

SHEET 1 OF 1

ANNEXURE-I

SINGE LINE DIAGRAM FOR 220V DC SYSTEM

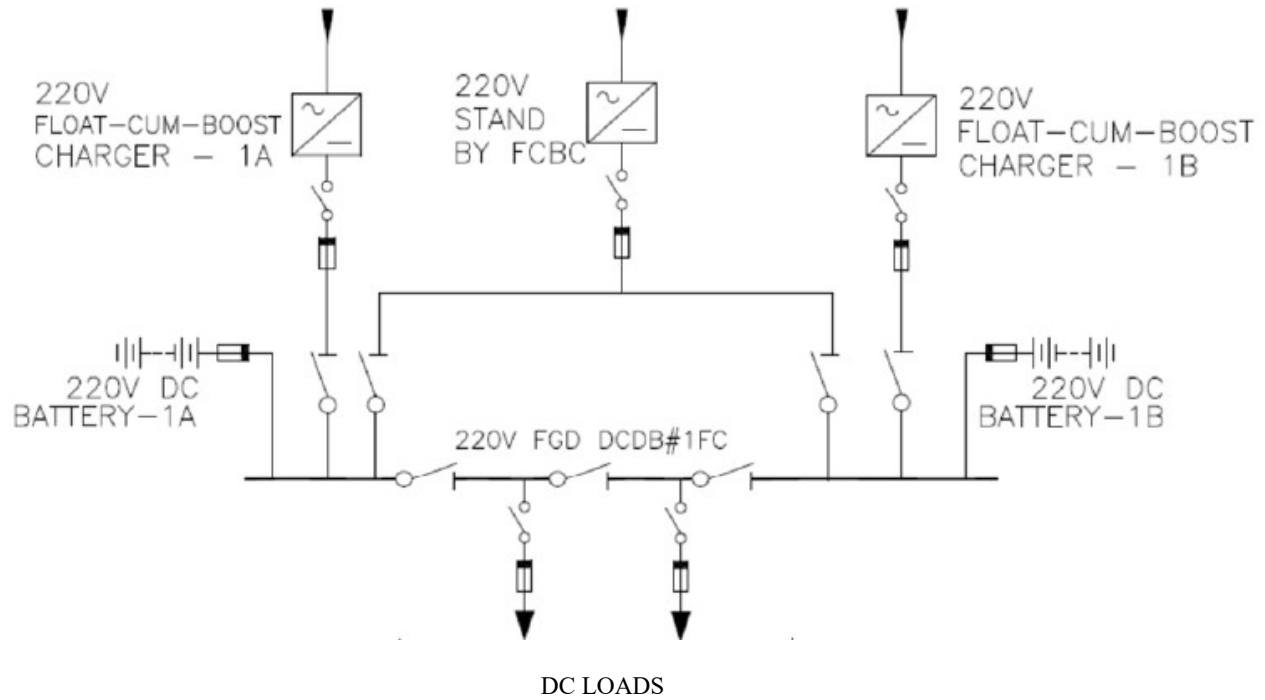



TECHNICAL SPECIFICATION FOR 220V DC Lead Acid Plante Battery

SPECIFICATION NO. PE-TS-439-508-E001

VOLUME II

SECTION I

REVISION 0

DATE: 24.11.23

SHEET 1 OF 1

ANNEXURE-II

LOAD DUTY CYCLE

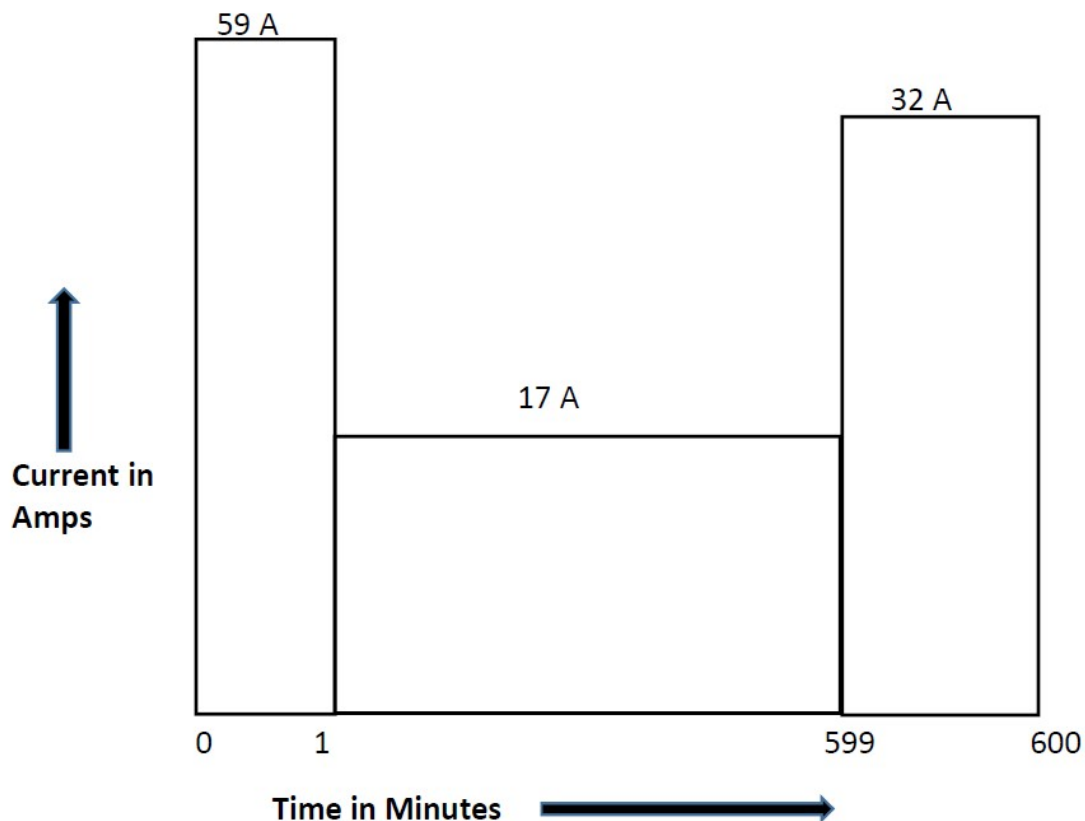

Duration	0-1 min	1-599 min	599-600 min
Current	59 A	17A	32A

FACTORS TO BE CONSIDERED FOR BATTERY SIZING:

1. MIN.ELECTROLYTIC TEMP. : 7.9 °C
2. END CELL VOLTAGE : 1.80 V/cell
3. DESIGN MARGIN : 20%
4. AGEING FACTOR : 1.25
5. TEMPERATURE CORRECTION FACTOR : IEEE 485 for Lead Acid shall be the principle for sizing the battery including temperature correction factor.
6. **MINIMUM BATTERY CAPACITY : 400AH**

Note:

1. Supporting Calculation for temp correction factor as per IEEE-485 shall be furnished for batteries which are not designed at 25 °C.

	TECHNICAL SPECIFICATION FOR 220V DC Lead Acid Plante Battery		SPECIFICATION NO. PE-TS-439-508-E001	
			VOLUME II	
	SECTION I		REVISION 0	
			DATE: 24.11.23	
			SHEET 1 OF 1	

ANNEXURE-III

DOCUMENTS REQUIRED ALONG WITH THE TECHNICAL OFFER

1. Battery sizing calculation with respect to load duty cycle (Annexure-II) enclosed with Section-I to be provided along with supporting documents (capability / discharge curve, temperature correction factor, float charging factor & published technical catalogue) for considered factors.
2. A copy of the sheet "Compliance certificate" with bidder's signature and company stamp.
3. A copy of sheet "Data Sheet-A" with required information and bidder's signature and company stamp.

**TECHNICAL SPECIFICATION FOR
220V DC Lead Acid Plante Battery**

SPECIFICATION NO. PE-TS-439-508-E001

VOLUME II

SECTION I

REVISION 0

DATE: 24.11.23

SHEET 1 OF 1

ANNEXURE-IV
Drawing/ documents schedule

BHEL Drawing No.	Drawing Title	Vendor Sub (Days)*	Bhel comment (Days)	Vendor Sub (Days)#	Bhel and Customer comment/approval (Days)	Total Engg Time (Days)
Primary Documents						
PE-V0-439-508-E102	GA AND BATTERY ROOM LAYOUT OF BATTERY BANK	21	9	7	18	55
PE-V0-439-508-E101	TDS FOR BATTERY	21	9	7	18	55
PE-V0-439-508-E103	BATTERY SIZING CALCULATION, FAULT CALCULATION AND CONNECTOR SIZING CALCULATION	21	9	7	18	55
PE-V0-439-508-E104	BILL OF MATERIAL FOR BATTERY	21	9	7	18	55
PE-V0-439-508-E108	LIST OF MANDATORY SPARES FOR BATTERY (\$\$)	21	9	7	18	55
Secondary Documents						
PE-V0-439-508-E105	FIELD QUALITY PLAN PLAN FOR BATTERY	21	9	7	18	55
PE-V0-439-508-E106	LIST OF E & C SPARES FOR BATTERY	21	9	7	18	55
PE-V0-439-508-E110	TYPE TEST REPORT FOR BATTERY (%%)	21	9	7	18	55
PE-V0-439-508-E111	CABLE TERMINATION ARRANGEMENT FOR BATTERY TERMINAL	21	9	7	18	55
PE-V0-439-508-E109	O & M MANUAL FOR BATTERY	within 30 days of issuance of MDCC				
NOTES:						
a) * 1st submission within indicated days from date of purchase order						
b) # Submission (within indicated days) after incorporating all BHEL comments						
c) \$\$ Primary document for delivery of Mandatory Spares only and not to be linked with Battery supply.						
d) %% Endurance tests report shall be submitted after conduction of the test.						
e) Primary documents shall be considered for Delay analysis and secondary documents shall be for engineering completion purpose						

1820369/2023/PS-PEM-EU



TITLE :

TECHNICAL SPECIFICATION FOR

220V DC LEAD ACID BATTERY

SPECIFICATION NO.

PE-SS-999-508-E001VOLUME NO. : **II**SECTION : **II**REV NO. : **01** DATE : 30/05/2016

SHEET : 1 of 7

SECTION - II
STANDARD TECHNICAL REQUIREMENTS



TITLE :	SPECIFICATION NO.
TECHNICAL SPECIFICATION FOR	PE-SS-999-508-E001
220V DC LEAD ACID BATTERY	VOLUME NO. : II
	SECTION : II
	REV NO. : 01 DATE : 30/05/2016
	SHEET : 2 of 7

1.0 TECHNICAL REQUIREMENTS

This specification covers the design, materials, constructional features, manufacture assembly, testing, packing and dispatch of 220V DC Lead-Acid Battery complete with all accessories.

In this specification, as erection and commissioning is not included in vendor's scope, Vendor shall still not be absolved of his responsibility of establishing the correctness of equipment at site.

It is not the intent to specify herein all the details of design & manufacture. However, the equipment shall conform in all respects to high standards of design engineering and workmanship and shall be capable of performing in continuous commercial operation up to bidder's guarantee. This enquiry covers the supply of 220V DC LEAD ACID BATTERY conforming to this specification.

2.0 CODES AND STANDARDS

Unless otherwise specified, the latest revisions of codes/standards as specified under Table-1 enclosed are applicable and shall referred to.

3.0 EQUIPMENT AND SERVICES TO BE PROVIDED BY THE BIDDER

The bidder shall supply the equipment and provide the services in accordance with the various sections of this specification and as per BOQ cum unpriced Price Schedule (Annexure-A) enclosed with NIT.

4.0 SERVICES AND EQUIPMENT TO BE EXCLUDED

- a. Civil works like foundation and cable cellar, flooring of the battery room etc.
- b. Ventilation of battery and charger room.
- c. 220V DCDB
- d. Power and control cables
- e. Erection of the equipment
- f. Battery charger, battery fuse box and discharge resistor

5.0 DESCRIPTION OF EQUIPMENT

5.1 BATTERY

All batteries shall be stationary storage Lead-Acid *high discharge* type conforming to IS-1652/IEC60896-11. The batteries shall meet the duty cycle requirements under all site and operating conditions as specified in data sheet 'A'. IEEE 485 shall be the principle for sizing the battery including temperature correction factor.

5.2 CONTAINER

Containers shall be made of transparent polymeric material, robust, heat resistant, leak proof, non-absorbent, acid/alkali resistant, non-bulging type and free from flaws such as wrinkles, cracks, blisters, pinholes etc. The marking for the electrolyte level shall be for upper & lower limits. Container shall be closed/sealed lid type. Open type cells are not



TITLE :	SPECIFICATION NO.
TECHNICAL SPECIFICATION FOR	PE-SS-999-508-E001
220V DC LEAD ACID BATTERY	VOLUME NO. : II
	SECTION : II
	REV NO. : 01 DATE : 30/05/2016
	SHEET : 3 of 7

acceptable. Lid and sealing compound shall be non-cracking type.

5.3 PLATES

The plates shall be designed for maximum durability during all service conditions including high rate of discharge and rapid fluctuation of load.

The separators shall maintain the electrical insulation between the plates and shall permit free flow of electrolyte. Proper arrangement to keep end plates in position shall be provided. Separators shall be suitable for continuous immersion in the electrolyte without distortion.

The positive and negative terminal posts shall be clearly marked

5.4 CONNECTIONS

Lead coated copper connectors (or a better product) shall be used for connecting up adjacent cells and rows. Bolts, nuts, clamps, washers etc as applicable in shall be provided. All the terminals and inter-cell connectors shall be fully insulated or shrouded. End take of connections from positive and negative poles of batteries shall be done through single core cables. Necessary support equipments and copper lugs for termination of these cables on batteries shall also be supplied by the contractor. Suitable numbers of inter rack connectors shall be supplied by the bidder to suit the battery room layout during detailed engineering.

All connectors and lugs shall be capable of continuously carrying the discharge current of the respective Batteries and through fault short circuit current which the battery can produce and withstand for the period declared. Successful bidder shall furnish necessary sizing calculations to prove compliance to the same.

5.5 VENT PLUG

Vent plug shall be provided in each cell. It shall be anti-splash type and having more than one exit hole to allow the gases to escape freely but prevent the acid spray from the battery. The design shall be such that the water loss due to evaporation is kept to minimum. In addition the ventilator shall be easily removed from topping up the cells and of such dimensions that the syringe type hydrometer can be inserted into the vent to take electrolyte sample.

5.6 SEDIMENT SPACE

Sufficient sediment space shall be provided beneath the plates to accommodate any plate deposit, which accumulates at the bottom of the cell over a reasonable life of battery without short-circuiting the plates.

5.7 The following information shall be marked on out side of each cell.

- Name, type and trade mark of manufacturer
- Country and year of manufacture
- Capacity at 10 hr discharge rate .
- Upper and lower electrolyte level
- Serial Number



TITLE :	TECHNICAL SPECIFICATION FOR	SPECIFICATION NO.	PE-SS-999-508-E001
	220V DC LEAD ACID BATTERY	VOLUME NO. :	II
		SECTION :	II
		REV NO. :	01 DATE : 30/05/2016
		SHEET :	4 of 7

5.8 ELECTROLYTE

The electrolyte comprise of battery grade sulphuric acid conforming to IS: 266 and water conforming to IS: 1069. The cells shall be shipped dry, uncharged with electrolyte supplied in non-returnable good quality polyethylene or other suitable containers.

Ten percent extra electrolyte shall be supplied to account for any spillage during transit.

5.9 BATTERY RACKS

- Wooden/FRP/Steel battery racks to be supplied as specified in datasheet-A. Wooden rack shall be made of best quality treated wood
- Racks shall be painted with at least two (2) coats of acid resistant/ anti corrosive paint.
- Racks shall be free standing type mounted on porcelain/hard rubber/ PVC Pad insulators as applicable.
- Numbering tags for each cell shall be attached on to the battery racks.
- Battery racks and other supporting/interconnecting accessories shall be as per layout arrangement to be approved by purchaser during contract engineering stage.
- The bottom tier of the stand shall not be less than 150 mm above the floor.
- Wherever racks are transported in dismantled conditions, match markings shall be provided to facilitate easy assembly.

6.0 Following minimum information shall be given on the instruction cards:

- Manufacturer's instructions for filling and initial charging of the battery together with starting and finishing charging rate
- Maintenance instructions
- Designation of cell in accordance with relevant standard.
- Storing conditions of electrolyte

7.0 LIFE

The guaranteed life of battery when operating under the specified conditions shall be furnished.

8.0 ACCESSORIES

Battery accessories shall be provided as specified in BOQ cum unpriced Price Schedule (Annexure-A) enclosed with NIT.

9.0 INSPECTION AND TESTING

Offered equipment shall be of type tested design. The bidder shall confirm compliance to quality plan enclosed with the specification, which is subject to customer/ BHEL approval and the inspection shall be carried out based on this approved Quality Plan (QP no. PE-QP-999-508-E002).



TITLE :	SPECIFICATION NO.
TECHNICAL SPECIFICATION FOR	PE-SS-999-508-E001
220V DC LEAD ACID BATTERY	VOLUME NO. : II
	SECTION : II
	REV NO. : 01 DATE : 30/05/2016
	SHEET : 5 of 7

9.1 Quality Assurance

All materials components and equipment's covered under this specification shall be procured, manufactured, inspected and tested as per the BHEL standards, quality plan number PE-QP-999-S08-E002 enclosed with this specification and which shall be complied with.

All acceptance and routine tests as per IS-1652 shall be carried out by the manufacturer. Charges for all routine and acceptance tests for all the materials shall be deemed to be included in the bid price.

9.2 Type, Routine and Acceptance Tests

Type, Routine and Acceptance tests to be performed as per Quality Plan(QP no. PE-QP-999-508-E002) enclosed with this specification.

10.0 PERFORMANCE GUARANTEE

Bidders shall guarantee that battery offered shall meet the duty cycle requirements as stipulated in this specification and as confirmed by them in technical data sheets. In case, the performance of battery at site is not as per the performance guarantee, the bidder will have to replace the battery at site free of cost.

11.0 INSTRUCTION MANUALS

11.1 Instruction manuals for the installation, operation and maintenance of battery to be supplied shall be furnished. The installation and maintenance manual shall contain the following.

- a) General description giving type and rating of various batteries.
- b) Technical data
- c) Salient constructional details.
- d) Instruction to be followed on receipt at site.
- e) Instructions for foundations, if any
- f) Erection procedures and checks.
- g) Procedure for filling of electrolyte.
- h) Commissioning procedures and site tests.
- i) Routine, periodic and preventive inspection and maintenance procedures.
- j) Safety rules.
- k) Possible faults, their causes and remedies.
- l) Type and routine test certificates.
- m) Catalogues, literatures and drawings.

1820369/2023/PS-PEM-EU



TITLE :

TECHNICAL SPECIFICATION FOR

220V DC LEAD ACID BATTERY

SPECIFICATION NO.

PE-SS-999-508-E001

VOLUME NO. : II

SECTION : II

REV NO. : 01 DATE : 30/05/2016

SHEET : 6 of 7

12.0 Bidder shall furnish field quality plan detailing out the specific quality control procedure covering receipt of material/equipment and handling at site, storage, erection, commissioning, post commissioning etc.

13.0 By all Bidders as technical offer:

- i. Battery sizing calculation with respect to load duty cycle enclosed with Section-I to be provided along with supporting documents (capability / discharge curve, temperature correction factor, float charging factor & published technical catalogue) for considered factors.
- ii. Unpriced Price Schedule (Annexure-A) as enclosed with NIT with “Quoted” word against items with bidder’s signature and company stamp.
- iii. A copy of the sheet “Compliance certificate” with bidder’s signature and company stamp.
- iv. A copy of sheet “Data Sheet-A” with required information and bidder’s signature and company stamp.



TITLE :

TECHNICAL SPECIFICATION FOR

220V DC LEAD ACID BATTERY

SPECIFICATION NO.

PE-SS-999-508-E001

VOLUME NO. : II

SECTION : II

REV NO. : 01 DATE : 30/05/2016

SHEET : 7 of 7

Table-1

LIST OF CODES AND STANDARDS FOR LEAD ACID BATTERY

- | | | |
|-----|---|-------------|
| 1. | STATIONERY LEAD ACID PLANTE BATTERY | IS 1652 |
| 2. | RECOMMENDED PRACTICE FOR SIZING LEAD ACID BATTERIES | IEEE 485 |
| 3. | SPECIFICATION FOR WATER FOR STORAGE BATTERIES | IS 1069 |
| 4. | SPECIFICATION FOR SULPHURIC ACID FOR LEAD ACID BATTERIES | IS 266 |
| 5. | RUBBER & PLASTIC CONTAINERS FOR LEAD ACID BATTERIES | IS 1146 |
| 6. | SYNTHETIC SEPARATORS FOR LEAD ACID BATTERIES | IS 6071 |
| 7. | SEALING COMPOUND FOR LEAD ACID BATTERIES | IS 3116 |
| 8. | METHODS OF TESTS FOR LEAD ACID BATTERIES | IS 8320 |
| 9. | SPECIFICATION FOR HIGH PERFORMANCE PLANTE'S CELLS | BS-6290 |
| 10. | ELECTRICAL VOCABULAR, PRIMARY CELLS AND BATTERIES. | IS: 1885 |
| 11. | STATIONARY LEAD-ACID BATTERIES – VENTED TYPES – GENERAL REQUIREMENTS & METHODS OF TESTS | IEC60896-11 |
| 12. | INDIAN ELECTRICITY RULES & INDIAN ELECTRICITY ACTS | |

Note:

Vendor to note that wherever IS is mentioned equivalent IEC is also acceptable. In case of any technical requirement not covered by IEC, technical requirement as per IS shall prevail.

SL. NO.		COMPONENT & OPERATIONS	CHARACTERISTIC CHECK	CLASS	TYPE OF CHECK	QUANTUM OF CHECK		REFERENCE DOCUMENT	ACCEPTANCE NORMS	FORMAT OF RECORD		AGENCY		REMARKS
1	2	3	4	5	6		7	8	9	D *	10		11	
					M	C/N						M	C	N
MANUFACTURER/ BIDDER/ SUPPLIER NAME & ADDRESS 														
STANDARD QUALITY PLAN CUSTOMER TSGENCO PROJECT 1X800MW KTPS FGD ITEM:- LEAD ACID BATTERY SYSTEM:- DC SYSTEM SPEC NO.:-PE-TS-XXX-508-E001 QP NO.:-PE-QP-999-508-E002, REV.01 P.O NO.:- SECTION:- DATE:- 30/06/2020 DATE:- SHEET 3 OF 3														
3.2	Acceptance Test													
a)	Verification of Markings	Visual	MA	Visual	Sample Plan as per IS: 8320	Sample Plan as per IS: 8320	IS:1652	IS:1652	Inspection Report	√	P	W	W	
b)	Verification of Dimensions	Dimension	MA	Measurement	-do-	-do-	-do-	-do-	-do-	√	P	W	W	
c)	Test for Capacity	Capacity	CR	Electrical & Measurement	-do-	-do-	-do-	-do-	-do-	√	P	W	W	
d)	Test for Voltage during discharge	Voltage during discharge	CR	Electrical & Measurement	-do-	-do-	-do-	-do-	-do-	√	P	W	W	
3.3	CONTAINER													
a)	Verification Constructional requirement	Visual	MA	Visual	Sample Plan as per IS:1146	-	IS:1652, IS:1146, IS:8320	IS:1652, IS:1146, IS:8320	Test Cert.	√	P	W	W	
b)	Verification of Markings	Visual	MA	Visual	-do-	-	-do-	-do-	-do-	√	P	W	W	
c)	High Voltage Test	Electrical	MA	Electrical	-do-	-	-do-	-do-	-do-	√	P	W	W	
d)	Drops Ball Test	Mechanical	MA	Mechanical	-do-	-	-do-	-do-	-do-	√	P	W	W	
e)	Plastic Yield Test	Mechanical	MA	Mechanical	-do-	-	-do-	-do-	-do-	√	P	W	W	
f)	Acid Resistance Test	Chemical	MA	Chemical	-do-	-	-do-	-do-	-do-	√	P	W	W	
g)	Hydraulic thrust endurance test	Physical	MA	Physical	-do-	-	-do-	-do-	-do-	√	P	W	W	
4.0	Battery Racks	Visual & Dimension	MA	Visual & Dimension	1 Sample	1 Sample	Approved drg/ doc	Approved drg/ doc	-do-	√	P	W	V	
5.0	Accessories	Visual & Dimension	MA	Visual & Dimension	100%	100%	Approved drg/ doc	Approved drg/ doc	-do-	√	P	W	-	
6.0	Cable Lugs and Terminal Plate	Visual	MA	Visual	100%	100%	Approved drg/ doc	Approved drg/ doc	-do-	√	P	W	-	
7.0	Packing	Verification of Packing Methods, Finish & Completeness	MA	Visual	100%	100%	Approved drg/ doc/ As Per Manufacturer Std./ Approved Packing drg/ doc(\$\$)	Approved drg/ doc/ As Per Manufacturer Std./ Approved Packing drg/ doc(\$\$)	-do-	√	P	W	-	(\$\$)- Approved Packing Drg./ Doc Applicable for Export Job/Projects

NOTES:-

- Wherever IS standard is mentioned, equivalent IEC/International standard is also acceptable as per applicability of test. In case of any technical requirement not covered by IEC, technical requirement as per IS shall prevail.
- BHEL Reserves the right for conducting repeat test, if required.
- Photographs of complete Battery Package items after packaging to be sent to BHEL-Purchase Group for review before issuing MDCC.
- In case, any changes in QAP commented by customer at contract stage shall be carried out by bidder without any implication to BHEL/Customer.
- Project Specific QAP to be developed based on customer requirement. .
- Packing shall be suitable for storage at site in tropical climate conditions.

LEGEND :-

* RECORDS, IDENTIFIED WITH "TICK"(√) SHALL BE ESSENTIALLY INCLUDED BY SUPPLIER IN QA DOCUMENTATION,

** M: SUPPLIER/ MANUFACTURER/ SUB-SUPPLIER, C: MAIN SUPPLIER/ BHEL/ THIRD PARTY INSPECTION AGENCY, N: CUSTOMER

P: PERFORM, W: WITNESS, V: VERIFICATION, AS APPROPRIATE

MA: MAJOR, MI: MINOR, CR: CRITICAL, D: DOCUMENTATION

BHEL					BIDDER/SUPPLIER		FOR CUSTOMER REVIEW & APPROVAL								
ENGINEERING			QUALITY			Sign & Date		Doc No.		Sign & Date		Name		Seal	
Prepared By	Sign & Date	Name	Prepared By	Sign & Date	Name	Seal		Reviewed By	Sign & Date	Name	Seal				
Checked By		Kanhaiya Kumar	Checked By		Kunal Gandhi	Seal		Checked By							
		Manish Shukla			Ritesh K Jaiswal										

ANNEXURE-A

STANDARD QUALITY PLAN

STANDARD QP NO. : PE-QP-999-508-E002, REV. 01

LIST OF TYPE TEST FOR LEAD ACID BATTERY

S No	Test	Type test description	Referred standard	Type Test to be specifically conducted (Yes/No)	BHEL/Customer's approval/Review Req. on test certificate (Yes/No)
1	Type Test	• Test for Capacity & Voltage during discharge	IS:1652	Y	Y
		• AH & WH efficiency Test	IS:1652	Y	Y
		• Test for loss of capacity on storage (Retension of Charge)	IS:1652	Y	Y
		• Endurance Test	IS:1652	Y	Y
		• Loss of water test	IS:1652	N	Y
		• Test for suitability for floating batteryoperation	IS:1652	N	Y
		• Internal resistance and short circuit test	IS:1652	N	Y