

TECHNICAL PRE- QUALIFICATION REQUIREMENT

Name of customer: SJVN ARUN-III POWER DEVELOPMENT COMPANY (P) LTD. (SJVN LTD.)

Name of consultant: SJVN ARUN POWER DEVELOPMENT COMPANY LTD. (SAPDC LTD.)

Name of Project: 4X225MW ARUN-III, HYDRO ELECTRIC PROJECT, NEPAL

Name of Item: AIR-CONDITIONING & VENTILATION SYSTEM

PQR Sr. No	PQR Description	Supporting Document to be attached
1.	<p>The bidder shall have designed, supplied, erected, tested and commissioned at least one ventilation system of 35,000cmh (70% of the volume for GIS Hall) or higher rating pressurized ducted ventilation system in Power Plant or Sub-stations or Industrial Complex etc. in last 20 years and supplied equipment should be in (#) successful operation for at least 2 years in last 10 years as on originally scheduled date of technical bid opening of BHEL tender.</p> <p>(#) Successful operation means certificate issued by the Customer certifying the operation without any adverse remark.</p>	<p>a) Copy of Purchase Orders</p> <p>b) Break up of Ventilation systems supplied.</p> <p>c) Performance Certificate/ Letter/ MOM from customer for satisfactory as required in PQR description sr. no.-1.</p>

Prepared By:
Ayushi Jindal
(Sr. Engineer-TBEM)

Checked By:
TD Tripathi
(Manager-TBEM)

Approved By:
S K Shukla
(Sr. DGM-TBEM)

705358/2022/TBG-TB_ENG_SR



BHARAT HEAVY ELECTRICALS LIMITED

TRANSMISSION BUSINESS ENGINEERING MANAGEMENT

DOCUMENT No.	TB-405-553-001	Rev. No.	00		Prepared	Checked	Approved
TYPE OF DOC.	TECHNICAL SECIFICATION	NAME		AJ	TDT	SKS	
TITLE							
AIR-CONDITIONING & VENTILATION SYSTEM (400KV-Gas Insulated Switchyard)				DATE	22.02.22	22.02.22	22.02.22
				GROUP	TBEM	Job No.	405
CUSTOMER	SJVN ARUN-III POWER DEVELOPMENT COMPANY (P) LTD. (SAPDC)						
CONSULTANT	SJVN LTD.						
PROJECT	4x225MW ARUN-III, HYDRO ELECTRIC PROJECT, NEPAL						

विषय-सूचि /CONTENTS

अनुभाग / Section	विवरण /Description	पृष्ठ संख्या/ No of Pages
1	Intent, System and Scope	21
2	Customer Equipment Specification	09
3	Project Details and General Technical Specifications	36
4	List of Drawings & Documents	01
5	Enclosures to Specification Annexures	06 47

Rev No.	Date	Altered	Checked	Approved	REVISION DETAILS		

COPYRIGHT AND CONFIDENTIALITY
The information on this document is the property of BHARAT HEAVY ELECTRICALS LTD.
It must not be used directly or indirectly in anyway detrimental to the interest of the company

	CLIENT – SJVN ARUN-III POWER DEVELOPMENT COMPANY (P) LTD. (SAPDC)	TB-405-553-001
	CONSULTANT- SJVN LTD.	Rev. 00
	PROJECT: 4x225MW ARUN-III, HYDRO ELECTRIC PROJECT, NEPAL TECHNICAL SPECIFICATION FOR AIR CONDITIONING & VENTILATION SYSTEM	Page 1

SECTION-1 INTENT, SYSTEM REQUIREMENT, DESIGN CRITERIA & SCOPE

1.0. INTENT OF SPECIFICATION

1.0.1. This specification covers the design, manufacture, inspection and testing at bidder's and/ or his sub vendor's work(s), proper packing, transportation & delivery, supervision of erection, testing and commissioning, final painting and carrying out acceptance tests at site, handing over and warranty for two years of **Air-Conditioning and Ventilation System** as detailed in this section and in various other sections of this specification for different rooms located inside the 400KV Gas Insulated switchyard (GIS) control Building and GIS Hall of **4x225MW ARUN-III, HYDRO ELECTRIC PROJECT, NEPAL**.

1.0.2. The requirement(s) specified under 'SECTION 2, SECTION 3, SECTION 4' and 'SECTION 5' of this specification shall be considered as part of this section. In case of variance between sections, the requirement of Section-1 shall prevail. Customer equipment specification in Section-2 shall be adhered to by the bidder. This specification shall be read in conjunction with all its enclosures. In case of any discrepancy arising between this job specification & its enclosures, the most stringent of all (as determined by purchaser) shall be followed. In all cases, end customer's (M/s SJVN) specification requirement enclosed in various annexures are binding and are to be followed by bidder.

1.0.3. It is not the intent to specify herein all the details of design and manufacture. However, the equipment shall conform in all respects to high standards of design, engineering and workmanship and shall be capable of performing the required duties in a manner acceptable to Purchaser/ Owner, who will interpret the meaning of drawings and specifications and shall be entitled to reject any work or material, which in his judgment is not in full accordance herewith.

1.0.4. The bidder shall be deemed to have understood completely all the tender drawings and documents and quoted accordingly.

1.0.5. The bidder has to note carefully the parameters, estimated capacities of equipment indicated and the tender drawing in the specification are only for guidance of the bidder. The system shall be designed as per relevant standards / codes and exact capacities and quantities are to be estimated by the bidder. All such estimations and design calculations shall be submitted for Purchaser's approval.

1.0.6. *Deviation:* In case of any deviation, the bidder shall indicate separately the deviations clause-wise with respect to the specification in the 'Schedule of Deviation' given in schedule 1 of section-5. Deviations in any other form including clarifications / assumptions / etc. will not be considered and it will be construed that the bid conforms strictly to the specification.

1.0.7. The Contract shall be on Unit Rate basis for the quantities furnished by BHEL. The quantities furnished in Price bid (BOQ) are as per preliminary design only. BHEL reserves the right for quantity variation (upward/ downward) due to any reason upto $\pm 30\%$ of total contract value at same unit rate and terms & conditions during execution of contract.

1.0.8. The Purchaser, Consultant and Customer in this specification stand for BHEL, SJVN LTD. and SAPDC respectively. The successful bidder shall be referred to as Contractor.

	CLIENT – SJVN ARUN-III POWER DEVELOPMENT COMPANY (P) LTD. (SAPDC)	TB-405-553-001
	CONSULTANT- SJVN LTD.	Rev. 00
	PROJECT: 4x225MW ARUN-III, HYDRO ELECTRIC PROJECT, NEPAL TECHNICAL SPECIFICATION FOR AIR CONDITIONING & VENTILATION SYSTEM	Page 2

1.1. AIR CONDITIONING AND VENTILATION SYSTEM

This system shall be designed with the objective of providing Air Conditioning and Ventilation in different rooms located inside the 400KV Gas Insulated switchyard (GIS) Control Building and GIS Hall of 4x225MW ARUN-III, HYDRO ELECTRIC PROJECT, NEPAL

1.1.1. CODES AND STANDARDS

The design, manufacture, inspection and testing of Air Conditioning and Ventilation system shall comply with all currently applicable statutes, regulations and safety codes in the locality where the equipment is to be installed. The equipment shall also conform to the latest applicable Indian/ British/American standards.

The equipment shall conform to the latest edition to the following standards:

- ASHRAE Guide and data book: American Society of Heating, Refrigerating and Air Conditioning Engineers.
- IS: 655: Metal Air Ducts
- IS 4720: Indian Standard Code of Practice for Ventilation of Surface Hydel Power Stations.
- IS: 3103: Code of practice for industrial ventilation
- ANSI 62: Ventilation for acceptable indoor air quality
- IS 659: Safety code for Air-conditioning.
- IS 4894: Centrifugal fans
- IS 7613: Air filters
- IS 277: Specification for Galvanized Steel Sheets

1.1.2. SCOPE

The purpose of the system is to provide Air-Conditioning & Ventilation for different areas of GIS Area of ARUN-III (4 x 225 MW) under the scope of BHEL-TBG. To achieve proper working conditions inside GIS Area, HVAC system is provided to serve the following purpose:

- i. To prevent temperature stratification
- ii. To remove contaminated air
- iii. To remove waste heat from equipment
- iv. To provide outside fresh air necessary for human comfort

Air conditioning and Ventilation System for various areas of 400KV GIS Switchyard control building shall be provided as below:

Air-Conditioning System

Sr. No.	Area to be Air-Conditioned	Type of Air conditioners
1.	Switchyard Control Room	2 TR Split AC units (100 % working)
2.	Control & Protection Room	3 TR Cassette AC units (100 % working)
3.	Office Room	2 TR Split AC units (100 % working)

	CLIENT – SJVN ARUN-III POWER DEVELOPMENT COMPANY (P) LTD. (SAPDC)	TB-405-553-001
	CONSULTANT- SJVN LTD.	Rev. 00
	PROJECT: 4x225MW ARUN-III, HYDRO ELECTRIC PROJECT, NEPAL TECHNICAL SPECIFICATION FOR AIR CONDITIONING & VENTILATION SYSTEM	Page 3

Ventilation System

S.No.	Name of premises	Supply Air System	Exhaust Air System
1.	GIS Hall	Centrifugal fans 3X50% (2 working+1 Standby) along with ducting for supply air system.	Exhaust Fans
2.	LT Switchgear Room	Wall mounted supply air fans	Louvers
3.	Inert Gas Room	Fresh air through intake louvers	Wall mounted exhaust air fans
4.	Transformer Room	Fresh air through intake louvers	Wall mounted exhaust air fans

*As per heat load and ventilation fan calculation, actual load / capacity of the air conditioning system for above areas shall be worked out during detailed engineering stage. Exact dimensions of different areas may be referred from architecture drawing.

All the equipment for HVAC system shall be designed for continuous duty.

1.1.3. AIR CONDITIONING SYSTEM

Split / Cassette type Air Conditioning unit

(Applicable for Control room, CRP room and Office room)

Refer drawing: Conceptual Layout of CRP Room in Switchgear Building of 400kV Switchyard of Arun 3 HEP (TB-3-406-316-021), R06

- Split / Cassette type air conditioners (air cooled) with R-134a/R-407c/410a refrigerants complete with all accessories described hereinafter shall be provided to cater to the air conditioning requirements for auxiliary / local control room etc. Local isolator / MCB shall be provided with split/cassette units.
- Hand operated remote and accessories as specified shall be provided. Each split/cassette unit shall be provided with suitable rating stabilizer.
- Copper refrigerant piping complete with insulation between the indoor and remote outdoor condensers as required.
- PVC drain piping of suitable length from indoor units to the nearest drain point for each air conditioner.
- Split AC/ Cassette AC shall confirm to latest BEE star rating.
- One Lot of MS brackets and M.S. frame for indoor & outdoor units respectively and fixing hardware like anchor bolts, nuts, fittings etc. as would be necessary for installation of each unit.

	CLIENT – SJVN ARUN-III POWER DEVELOPMENT COMPANY (P) LTD. (SAPDC)	TB-405-553-001
	CONSULTANT- SJVN LTD.	Rev. 00
	PROJECT: 4x225MW ARUN-III, HYDRO ELECTRIC PROJECT, NEPAL TECHNICAL SPECIFICATION FOR AIR CONDITIONING & VENTILATION SYSTEM	Page 4

Design Criteria for areas covered with Split AC & Cassette AC units:

Ambient Conditions	
Average Max Temp	30 Deg C
Average Min Temp	20 Deg C
	<i>For further details for Outdoor design conditions, please refer Section-3.</i>
Desired Inside Condition	24°C±1°C
Floor Area	As per switchyard control building layout drawing
Exposed glass area	As per switchyard control building layout drawing
Exposed wall area	As per switchyard control building layout drawing
False ceiling	In all air conditioned area as per switchyard control building layout drawing
Illumination Heat load	2 Watt per sq. ft. or actual whichever is higher.
Occupancy	The Occupancy considered shall be 1 person in 30 SQM or (actual) whichever is more.

- A design margin of 5% on total sensible and latent heat shall be considered while designing the AC capacity for each area.
- **Split AC/Cassette AC shall be selected for Average MAX temp: 40 deg C**
- Equipment load to be considered for calculating heat load of different areas under air conditioning and ventilation system as envisaged in this technical specification shall be as follows:

Sl. No	Areas	Equipment heat dissipation Load (kW)
1.	Switchyard Control Room	3
2.	Control & Protection Room	1.5
3.	Office Room	0.5

✓ **Notes:**

Heat Load calculation for each area mentioned above will be submitted for customer/ consultant approval during detailed engineering stage. Accordingly, the number of AC units shall be finalized.

1.1.4. VENTILATION SYSTEM

Fresh air supply through fresh air blower shall be fed to following area as mentioned below:

Three Nos. Ventilation Blowers (2W+1S) each of capacity 50% of the total required fresh air for the ventilation of the following area.

A. GIS building at EL.557.0M

These fans shall be located in switchyard area Ventilation room. Ventilation system shall be designed such that fresh air requirement shall be 100% of the total quantity of air required for maintaining desired temperature in above mentioned areas. Supply/ fresh air shall be distributed through duct based on layout.

	CLIENT – SJVN ARUN-III POWER DEVELOPMENT COMPANY (P) LTD. (SAPDC)	TB-405-553-001
	CONSULTANT- SJVN LTD.	Rev. 00
	PROJECT: 4x225MW ARUN-III, HYDRO ELECTRIC PROJECT, NEPAL TECHNICAL SPECIFICATION FOR AIR CONDITIONING & VENTILATION SYSTEM	Page 5

- i. The supply air quantity requirement will be worked out based on air changes as per IS:4720. The system shall be according to equipment load and according to suitable air changes per hour. The criterion that gives the highest flow rate will be considered for design & selection of the equipment.
- ii. In order to meet the above requirements, 3x50% Fresh air blowers shall be provided.
- iii. For Exhaust of Stale air from GIS area, set of exhaust air fans to exhaust 30 % of air requirement shall be provided. Provisions shall also be made for an automatic shutdown of the fresh air blowers to the respective area in case of fire by using a signal of fire protection system. In such a case all exhaust fans shall work as a smoke exhaust fans.
- iv. There shall be positive pressure inside GIS building.

B. LT Switchgear Room

Set of wall mounted axial flow supply air fans with pre-filter and fine filter for ventilation of LT Switchgear room at EL. 557.0M.

- i. All the ventilation fans shall operate on 100% fresh air considering 8 air changes per hour (ACPH) for LT Switchgear room.
- ii. Supply air fans of suitable capacity (CMH) & required static head (WC) each having pre filter/fine filter, rain protection cowl, bird screen and mounting arrangement shall be provided for positive pressurization of the LT Switchgear room. Gravity Louvers will be provided at the air outlet areas of this room.

C. Inert Gas Room & Transformer Room

Set of wall mounted axial flow exhaust fans shall be provided for removal of foul air from Inert Gas Room and Transformer Room at EL. 557.0M.

Exhaust fans of suitable capacity (CMH) each having rain protection cowl, bird screen and mounting arrangement shall be envisaged for inert gas room and transformer room.

Note: Supply and exhaust fans of above mentioned areas shall be provided with their local starter/push button (3 phase DOL starter).

D. Ducting and Accessories

- 1 Lot – Pre-filters having efficiency of 90% down to 10-micron particle size at fan suction.
- 1 Lot – Fine-filters having efficiency of 95% down to 5-micron particle size at fan suction.
- Automatic motorized fire dampers with manual override facility including damper control panel shall be provided as per layout requirement. Fire rating of dampers shall be 90 minutes as per UL555 S standards. Control of motorized damper shall be automatic through fire panel and manual trough blower control panels. Fire Dampers shall be provided in wall crossing.

	CLIENT – SJVN ARUN-III POWER DEVELOPMENT COMPANY (P) LTD. (SAPDC)	TB-405-553-001
	CONSULTANT- SJVN LTD.	Rev. 00
	PROJECT: 4x225MW ARUN-III, HYDRO ELECTRIC PROJECT, NEPAL TECHNICAL SPECIFICATION FOR AIR CONDITIONING & VENTILATION SYSTEM	Page 6

- 1 Lot – GSS Ducting (as per IS-277) with 275 g/sq.m. of zinc coating sheet metal work with thickness varying from **18 Gauge to 26 Gauge** as per air flow requirement and code requirement, complete with powder coated mild steel construction diffusers and grills, hangers, supports, flexible connections.
- All the ducts for AC & ventilation System shall be supplied pre-fabricated.
- Filter frame structure for filter fixing in fan room shall be provided by the contractor.
- Elbows, tees, supports, fixations, foundation plates including anti vibration pads, hangers, inserts, filters including all necessary grills, louvers, outside air louvers, adjusting duct dampers etc. to complete the ducting network.

1.1.5. Design Criteria and Technical Requirement

Area to be Ventilated	ACPH	Equipment Heat Dissipation Load (kW)
GIS Hall	4	72
LT Switchgear Room	8	16
Inert gas Room	8	2
Transformer Room	8	75
Maximum air velocity through ventilation duct	In Main Ducts: 11m/s In Branch Ducts: 8m/s	
Average Ambient Temperature	30°C	
Lighting load	2 W /sqft (as per standard practice for industrial ventilation)	

- All the fan units shall be reasonably noise and vibration free in operation and therefore of reasonably low speed. RPM of axial flow fans shall be restricted within 1200 to reduce their noise level. Outlet air velocity of all fans shall be restricted within 12 m/s.
- Casing for centrifugal and axial flow fans shall be reasonably leak proof.
- The first critical speed of the rotating assembly shall be at least 25% above the operating speed.
- Fan wheels shall be statically and dynamically balanced according to AMCA standard. Fans of 5 HP and above sizes must be dynamically balanced.

✓ **Notes:**

Ventilation fan calculation sheet for different areas mentioned above of GIS control building & GIS Hall shall be submitted for customer/ consultant approval during detailed engineering stage.

For space constraint for Ventilation ducting in GIS building, Crane Clearance Diagram drawing no. TB-CCD-405-563-221-Rev01 to be referred. Contractor shall be binding to design ducting within the allocated space.

1.1.6. CONTROL & POWER SUPPLY REQUIREMENT

- Single-phase switch socket/receptacles (32A) shall be provided by BHEL for each of the split AC units (2TR) at operating height in control room and office. Three-phase four wire MCB/TPN switch (32A) shall be provided by BHEL for each of the Cassette AC units (3TR) at operating height in CRP

	CLIENT – SJVN ARUN-III POWER DEVELOPMENT COMPANY (P) LTD. (SAPDC)	TB-405-553-001
	CONSULTANT- SJVN LTD.	Rev. 00
	PROJECT: 4x225MW ARUN-III, HYDRO ELECTRIC PROJECT, NEPAL TECHNICAL SPECIFICATION FOR AIR CONDITIONING & VENTILATION SYSTEM	Page 7

room. However, connection cable from AC to receptacles/switch including plug top shall be supplied by the contractor. *All cabling between the indoor and outdoor unit shall be supplied by contractor.*

- b. Three-phase four wire MCB/TPN switch (32A) shall be provided by BHEL for each of supply air fans in LT switchgear room and for exhaust air fans in transformer room. Single-phase switch socket/receptacles (16A) shall be provided by BHEL for each of the exhaust air fans in inert gas room. Also necessary cabling from receptacles to each fan's 3-phase DOL local starter shall be supplied by the contractor.
- c. One (1) no. dedicated Power distribution board in ventilation room of 400 kV GIS Hall shall be provided by BHEL.
- d. AC & Ventilation equipment shall have all provisions for control & monitoring of ventilation system through SCADA panel located in control room building. All necessary field instruments required as per IO list (to be finalized during detailed engineering) shall be supplied & installed by the contractor.
- e. Control and annunciation of vital signals for AC & Ventilation system shall have provisions for interface of with SCADA system, additional list of such signals shall be decided during detailed engineering stage.

1.2. Drawings & Documents to be submitted

Drawings, documents, design calculations literatures, manuals etc as mentioned below shall be submitted during detailed engineering.

For Approval:

- Calculation for fresh air requirement for ventilated area including sizing of motor, blower, ventilation duct etc.
- Tonnage calculation for Air Conditioning System
- Exhaust requirement calculation including sizing of motor, blower, etc.
- Coordination of fuse, MCCB, Power contactors
- Water requirement calculation (if any) for ventilation / air conditioning
- Loading on foundation
- OGA/Layout Drawings
- Ventilation Duct Plan & Section - Elevation wise at Switchyard
- Foundation Drawings for blowers, motors etc.
- Sub assembly drawing for pneumatic system of fire dampers
- Sub assembly drawing for bracket, clamp, insert, frame etc.
- All Electrical & Control Drawings such as Electrical Panels OGA, Cable Block & Termination Diagram, Schematic Diagram, JB/MB/Kiosk Diagram etc. in respect of HVAC System
- Technical Datasheet & Catalogue of every component used under this chapter
- GTP as in Schedule-3 of Section-5

For Reference

- Methodology for duct formation.
- Component wise weight schedule, lifting arrangement & safety arrangement
- Earthing arrangement drawings of panels / electrical installations etc.
- Erection Procedure documents along with all the drawings pertaining to this section
- O&M Manual

	CLIENT – SJVN ARUN-III POWER DEVELOPMENT COMPANY (P) LTD. (SAPDC)	TB-405-553-001
	CONSULTANT- SJVN LTD.	Rev. 00
	PROJECT: 4x225MW ARUN-III, HYDRO ELECTRIC PROJECT, NEPAL TECHNICAL SPECIFICATION FOR AIR CONDITIONING & VENTILATION SYSTEM	Page 8

1.3. Inspection & Testing requirement

All the equipment shall be inspected prior to dispatch in line with relevant IS, approved GTP/ drawing and technical specification, BHEL/ customer approved QAP.

Type Test:

The contractor shall only submit the certificates from Govt. approved labs/ accredited laboratories of the type tests listed below which should have been carried out within last five (5) years from the date of bid opening. These reports should be for the tests conducted on the equipment similar to those proposed to be supplied under this contract and the test(s) should have been either conducted at an independent laboratory or should have been witnessed by a client. In case the contractor is not able to submit report of the type test(s) conducted within last five years from the date of bid opening, or in case the type test report(s) are not found to be meeting the specification requirements, the contractor shall conduct the test without any financial implication to purchaser.

Acceptance Test:

- a. **Air conditioning system:** Room condition test shall consist of taking the reading of outside and inside temp at control room. Room condition test shall be done after stabilization of the system. The dry and wet bulb temp shall be measured by measured by sling psychrometer which will have accuracy of +/-0.5% with at least count of 0.5 degC. This will be carried out for 24 hrs. Continuously and readings will be taken every two hours. This test shall be carried out during summer during month April to June when the temp is generally high. Relative humidity shall be determined from psychometric chart.**Ventilation system:** Temperature test at the outlet of Fresh air blowers at mutually agreed locations. The dry bulb temp shall be measured by measured by sling psychrometer which will have accuracy of +/-0.5% with a least count of 0.5 deg C. This will be carried out for 24 hrs. Continuously and readings will be taken every two hours. This test shall be carried out during summer between months April to June.
- c. All shop testing and test at site as specified shall be carried out.
- d. The Noise level of the rotating derive shall not be exceed 85dB (A) at 1.5m from source inline with IS: 3103.

1.4. List of Mandatory Spares

Sl.no	Description	Quantity
1	Filter bank type and size used	4 sets of each used type
2	V-belts of type and size used	4 sets of each used type
3	Blower bearings	2 Sets
4	Exhaust Air Fans	1 no. of each used type
5	Grills, louvers, dampers, fixtures	10% of installed quantity
6	Industrial type vacuum cleaner suitable for cleaning of filter banks of ventilation system	1 Set
7	Axial air fans	2 no. of each used type

	CLIENT – SJVN ARUN-III POWER DEVELOPMENT COMPANY (P) LTD. (SAPDC)	TB-405-553-001
	CONSULTANT- SJVN LTD.	Rev. 00
	PROJECT: 4x225MW ARUN-III, HYDRO ELECTRIC PROJECT, NEPAL TECHNICAL SPECIFICATION FOR AIR CONDITIONING & VENTILATION SYSTEM	Page 9

8	Power contactors, fuses etc.	10% of installed capacity
9	Anemometer	1 no. of suitable capacity
10	Motor for fire dampers	1 no. of each type used
11	Bearing heating devices suitable for replacement of bearing (preferably of induction type)	1 Set
12	Bearing puller of suitable size for facilitating bearing replacement of coupling shaft etc.	1 Set

References:

- i. **Conceptual Layout of CRP Room in Switchgear Building of 400kV Switchyard of Arun 3 HEP - TB-3-405-316-021-Rev06.**
- ii. **400kV GIS Layout (Plan, Section & Isometric View) – TB-405-317-10-2 Rev02.**

Notes:

- ❖ Air Conditioning & Ventilation system for different areas of Gas insulated switchyard control building shall be designed as per the latest architecture drawings during detailed engineering stage.
- ❖ Customer/ consultant approval on all the technical data sheets of equipments /drawings/ documents for this package will be obtained during the detailed engineering stage.

1.5. SCOPE OF SUPPLY & SERVICES

The main items to be furnished under this contract are detailed in clause 1.11 and shall be in conjunction with other clauses of this specification.

Exact requirements shall be worked out during detailed engineering after award of contract. The scope of the work under the contract shall be deemed to include all such items, which although not specifically mentioned in the bid documents and/or in the bidder's proposal, but are required to make the equipment/system complete for its safe, efficient, reliable and trouble free operation, unless the same is specifically excluded from the Bidder's scope of work under clause 1.6 of this section.

- 1.5.1.** Basis of design, all calculations, equipment selection criterion, layout drawings/ schemes/ G.A. drawing and documents like data sheet/ technical particulars etc. are subject to Customer approval during detail engineering stage.
- 1.5.2.** Vendor to furnish characteristic curves for all major equipment offered indicating duty point during detailed engineering.
- 1.5.3.** All drawings and documents shall be computer based.
- 1.5.4.** Quality Requirements in the Technical Specification are indicating minimum requirements for inspection and testing. Vendor shall note that quality plan is subject to Customer & BHEL-approval during detail engineering stage.

	CLIENT – SJVN ARUN-III POWER DEVELOPMENT COMPANY (P) LTD. (SAPDC)	TB-405-553-001
	CONSULTANT- SJVN LTD.	Rev. 00
	PROJECT: 4x225MW ARUN-III, HYDRO ELECTRIC PROJECT, NEPAL TECHNICAL SPECIFICATION FOR AIR CONDITIONING & VENTILATION SYSTEM	Page 10

- 1.5.5. Necessary supports may be taken from nearest structure / walls / roofs / floors / column etc. by Vendor.
- 1.5.6. Fixing frame works for diffusers and grilles in the scope of Vendor.
- 1.5.7. Anchor fastener shall be used by vendor for fixing duct, pipes etc. wherever applicable.
- 1.5.8. Necessary supports and structures / frames etc. as required for supporting the duct / piping / equipments etc. is deemed to be included in the scope of Vendor
- 1.5.9. Vendor to furnish schedule of power and control cables. Vendor to furnish cable termination details interconnection drawings etc. during detail engineering stage.
- 1.5.10. The tools and machine required for erection of equipment shall be arranged by Vendor.
- 1.5.11. Tools & tackles as required for regular maintenance and General Spare parts shall be supplied by Vendor.
- 1.5.12. Instruments required for performance testing of various equipment / system of the package shall be arranged by Vendor at site.
- 1.5.13. Matching sockets / stubs (weld type) for flow switches and other instruments shall be supplied.
- 1.5.14. Besides the system performance as above, bidder shall guarantee major technical parameters of various equipments as per design basis / details furnished.
- 1.5.15. The guarantee tests shall cover but not limited to the following rated parameters for smooth operation of ventilation system.
- Design Auxiliary power consumption, Vibration and noise level etc.
 - Performance test of the ventilation system shall be carried out at site after proper installation. Bidder, as may be required to carry out site tests shall arrange all instruments, tools etc.
- 1.5.16. All calibrated instruments to be used for the tests at manufacturer's works/site shall be arranged by the bidder.
- 1.5.17. For Ventilation system, Motorized fire damper will be installed at supply air duct. Fire damper will close on receiving fire signal from fire protection system and shall also be possible manually from remote control panel. Also respective centrifugal fans/ ventilation systems shall trip on receiving fire signal from fire protection system
- 1.5.18. For motorized fire damper, power supply shall be derived by vendor from respective control panels. BHEL will not provide any feeder for fire damper. Suitable transformer shall be provided by bidder (if required) to derive the power input.
- 1.5.19. Feeder for a combination of fire damper etc. shall be derived from respective control panel by vendor. Distribution through junction box/ distribution board shall be in vendor scope and shall have provision for isolation of individual fire damper/ valves.
- 1.5.20. Tender drawings enclosed form the part of specification and the bidder shall check the space requirements.
- 1.5.21. *Bidder should suitably group the signals coming from various instruments etc. & the same shall terminate in local JB, from Local JB common cable to PLC/ DCS / SCADA panel shall be*

	CLIENT – SJVN ARUN-III POWER DEVELOPMENT COMPANY (P) LTD. (SAPDC)	TB-405-553-001
	CONSULTANT- SJVN LTD.	Rev. 00
	PROJECT: 4x225MW ARUN-III, HYDRO ELECTRIC PROJECT, NEPAL TECHNICAL SPECIFICATION FOR AIR CONDITIONING & VENTILATION SYSTEM	Page 11

selected. Any Electrical / C&I items and accessories like junction box, glands etc. shall be included by vendor in his scope. Only those items shall be provided free of cost which are categorically listed in the technical specification.

- 1.5.22.** In the event of any conflict between the requirements of two clauses of this specification documents or requirements of different codes and standards specified, the more stringent requirement as per the interpretation of the owner shall apply.
- 1.5.23.** Quality requirements in the Technical specification are minimum requirements for inspection and testing. Vendor to note that quality plans are subject to Customer approval during detail engineering stage.
- 1.5.24.** The drawings/ documents submitted by vendor shall be complete in all respects with revised drawing submitted incorporating all comments. Any incomplete drawing submitted shall be treated as non- submission with delays attributable to vendor's account. For any clarification/discussion required to complete the drawings, the bidder shall himself depute his personal to BHEL / Customer's place any number of time as per the requirement for across the table discussions/ finalizations/ submissions of drawings.
- 1.5.25.** Flat, platform type RCC / PCC foundation shall be provided for installing fan etc. (customer Scope) Vendor shall fix the equipment using anchor fasteners to secure the equipment obtain parameters related to vibration and noise. However, dimensions for the same will be furnished by contractor in layout drawings.
- 1.5.26.** Supplier to furnish drawings/ documents as per the drawings / documents distribution as per project requirement.
- 1.5.27.** Each motor terminal box shall be provided with cable gland and lugs for the size and type of power and control cable of respective motor.
- 1.5.28.** All electrical equipment shall be suitable for the power supply fault levels and other climatic conditions indicated in project information / synopsis / specifications enclosed.
- 1.5.29.** The bidder's proposal shall be for equipment in accordance with the tech. specification.
- 1.5.30.** The bidder shall furnish complete tech. Particulars in data sheet and schedules as specified elsewhere in the specification.
- 1.5.31.** Final coat of paint on all the equipment's / item covered under the package shall be done at the time of handing over of package
- 1.5.32.** Consumables and lubricants shall be in bidder's scope.
- 1.5.34. Bidder shall also consider the following while quoting for the system:**
- i) Supply, laying and termination of Power & Control cables including instrumentation and FO cable for Air Conditioning and Ventilation System shall be in purchaser's scope. Contractor shall have to choose their cables from the available sizes only and necessary modifications in their equipment for termination of these cables shall be made by contractor, supply of cable accessories such as lugs, glands, cable tags & markers etc. shall be included by the bidders in their offers.
 - ii) Necessary cable trays will be supplied on free issue basis to the contractor, however necessary hardware for fixing the same on walls or elsewhere shall be included by the bidders in their offers.

	CLIENT – SJVN ARUN-III POWER DEVELOPMENT COMPANY (P) LTD. (SAPDC)	TB-405-553-001
	CONSULTANT- SJVN LTD.	Rev. 00
	PROJECT: 4x225MW ARUN-III, HYDRO ELECTRIC PROJECT, NEPAL TECHNICAL SPECIFICATION FOR AIR CONDITIONING & VENTILATION SYSTEM	Page 12

iii) Earthing material viz. GS flat & wire will also be supplied on free issue basis to contractor; however, requirement shall be given by the bidders in their respective bids.

iv) Conducting performance guarantee tests as per approved procedure to the satisfaction of Owner / Purchaser and handing over an operational system to the owner. Procedure for performance guarantee test shall be submitted by contractor for customer review and approval.

v) Contractor shall submit valid Type test report for approval by owner. Fresh type test of equipment is not envisaged. It is presumed that equipment offered is duly type tested.

In case the type test reports are found un-satisfactory, tests shall be carried out afresh by contractor without any additional cost implication to BHEL.

1.5.35. Scope of services

Supervision of erection and commissioning is in bidder's scope. Bidder shall familiarize themselves with site prior to preparation of drawings for duct routing, equipment placement etc. Duct fabrication and erection drawings/procedure, pre-commissioning, commissioning checklist/procedure shall be provided by bidder.

- i) Design rectification engineering (if any) is included in contractor's scope. In case of revised inputs or site feedback, preparation and submission of revised engineering outputs shall also be in the scope of contractor.
- ii) Although Erection and Commissioning is not included in contractor's scope, the contractor shall be fully responsible for establishing the correctness of engineering and equipment at site.
- iii) Preparations of cable interconnection diagram for equipment supplied under this contract and accordingly offer guidance to the purchaser for laying necessary cables. Termination details shall also be furnished.
- iv) Painting of all the equipment shall be as per customer equipment specification.
- v) After completion of supervision of erection and commissioning of the system, the bidder shall train site engineers of Purchaser/Owner so that they are fully conversant with both electrical and mechanical part of this package.
- vi) Bidders to ensure that sufficient quantity of spares is made available for timely completion of commissioning of the system. The bidder shall furnish a list of commissioning spares that will be brought by him. The unused commissioning spares shall be returnable to the bidder.

Obtaining approval on documents & installations.

- i) Obtaining, "As Built" certification from purchaser or owner on applicable drawings. Completing documentation as per specification requirement.
- ii) Obtaining customer's written acceptance of satisfactory completion of job. (Acceptance of PG + handing over of system and mandatory spares (if any)).
- iii) Any other service not explicitly illustrated herein but which may be required to complete the system with its desired functionality or in the spirit of contract shall also deemed to be under the scope of bidder.

	CLIENT – SJVN ARUN-III POWER DEVELOPMENT COMPANY (P) LTD. (SAPDC)	TB-405-553-001
	CONSULTANT- SJVN LTD.	Rev. 00
	PROJECT: 4x225MW ARUN-III, HYDRO ELECTRIC PROJECT, NEPAL TECHNICAL SPECIFICATION FOR AIR CONDITIONING & VENTILATION SYSTEM	Page 13

Civil Works

- Major civil works such as room & foundations for various HVAC equipment shall be in purchaser's scope. The Bidder shall however supply foundation bolts & hardware
- Wall openings details at suitable locations for duct & ventilation fans shall be furnished by the contractor.
- Furnishing of details for construction of outdoor unit's mounting arrangement.
- Providing necessary guidance to / coordination with civil contractor so that appropriate sized / correctly located cut outs are made (by civil contractor) for installation of grilles.

1.6. Exclusions

- Receipt of material, Unloading and safe storage of all material/components at site.
- Erection, Testing and Commission at site, however supervision of ETC shall be in contractor's scope.
- Supply, laying and termination of power & control cables, Instrumentation and FO cable are excluded. The bidder shall choose from the BHEL procured cables listed in Annexure-C to this section & furnish quantity and type of cables required complete system in their respective bids.
- Supply of necessary cable trays for laying cables, however hardware for fixing the same on wall trenches or elsewhere shall be included by the bidder in his bid.
- Supply of GI flat for earthing of equipment.
- Major civil works such as room & foundations for various HVAC equipment.

1.7. Utilities Available

Construction water and electricity shall be available at one point each. Contractor shall be required to make own arrangement for taking supplies from there.

1.8. Engineering Drawings/ Documents

Engineering shall start immediately after the award of the contract.
Submission & approval of all drg. / data sheet – as per tender requirement.

1.9. OPERATION & MAINTENANCE (O&M) MANUAL

Operation and Maintenance manuals shall be specifically compiled for the project by the bidders. The draft O&M manual shall be submitted along with the supply of the items. The O&M manual shall contain the following information:

- Description of the system and equipment with design particulars.
- Instruction for erection.
- Instruction for operation, maintenance and repair.
- Recommended inspection practices and inspection schedule.
- Ordering information for all replaceable parts.
- Recommendation for type of lubricants and frequency of lubrication.

	CLIENT – SJVN ARUN-III POWER DEVELOPMENT COMPANY (P) LTD. (SAPDC)	TB-405-553-001
	CONSULTANT- SJVN LTD.	Rev. 00
	PROJECT: 4x225MW ARUN-III, HYDRO ELECTRIC PROJECT, NEPAL TECHNICAL SPECIFICATION FOR AIR CONDITIONING & VENTILATION SYSTEM	Page 14

1.10.Handing & Taking Over

It is the responsibility of the contractor to maintain the Air conditioning and Ventilation system for switchyard till PG test conducted successfully and it is handed over to customer. Any defect noted during the period shall be rectified by the contractor without any price implication to BHEL. Also suitable PG tests shall be conducted by the contractor to show the achievement of guaranteed parameters in line with the requirements of specification/ standards/ codes and to the satisfaction of Purchaser/ Owner.

1.11.Various Heads to be quoted for

Based on the above input it is recommended that the bidders shall submit their offers in the prescribed format only.

MAIN SUPPLY

Sl. No.	Item Description	Unit	Qty.	Remarks	Unit Ex-Works	Total Ex-Works
1	CENTRIFUGAL FAN WITH MOTOR - 25000 CMH	No.	3	Supply air type Centrifugal fan (2W+1S) with motor, V-belt drive, pulley, casing alongwith fixing hardware and all accessories as per technical specification.		
2	SPLIT AC UNIT - 2 TR	No.	4	High wall type split unit of 2TR capacity each complete with outdoor condensing units, compressor and high wall type indoor evaporator unit with cordless remote controller, power cables between outdoor and indoor units and to power supply switch, copper refrigerant piping between indoor & outdoor unit, PVC drain piping from indoor units, voltage stabilizer, and first charge of refrigerant and alongwith brackets for mounting of outdoor unit.		
3	CASSETTE AC UNIT - 3TR	No.	3	Cassette AC unit of 3TR capacity each complete with outdoor condensing units, compressor and indoor evaporator unit with cordless remote controller, power cables between outdoor and indoor units and to power supply switch, copper refrigerant piping between indoor & outdoor unit, PVC drain piping from indoor units, voltage stabilizer, and first charge of refrigerant and alongwith brackets for mounting of outdoor unit.		
4	PRE FILTER	No.	18	size 610X610mm for GIS Ventilation System through centrifugal fans		
5	FINE FILTER	No.	18	size 610X610mm for GIS Ventilation System through centrifugal fans		
6	GSS DUCT SHEET - 24 G - VENTILATION SYSTEM	SqMtr	240	Pre-fabricated Ducting fabricated from GSS having zinc coating as per class 275 of IS 277 complete with hangers, joints/ washers.		
7	GSS DUCT SHEET - 22 G - VENTILATION SYSTEM	SqMtr	270	Pre-fabricated Ducting fabricated from GSS having zinc coating as per class 275 of IS 277 complete with hangers, joints/ washers.		
8	GSS DUCT SHEET - 20 G - VENTILATION SYSTEM	SqMtr	50	Pre-fabricated Ducting fabricated from GSS having zinc coating as per class 275 of IS 277 complete with hangers, joints/ washers.		

	CLIENT – SJVN ARUN-III POWER DEVELOPMENT COMPANY (P) LTD. (SAPDC)	TB-405-553-001
	CONSULTANT- SJVN LTD.	Rev. 00
	PROJECT: 4x225MW ARUN-III, HYDRO ELECTRIC PROJECT, NEPAL	Page 15
TECHNICAL SPECIFICATION FOR AIR CONDITIONING & VENTILATION SYSTEM		

9	GSS DUCT SHEET - 18 G - VENTILATION SYSTEM	SqMtr	20	Pre-fabricated Ducting fabricated from GSS having zinc coating as per class 275 of IS 277 complete with hangers, joints/ washers.		
10	SUPPLY AIR GRILL WITH VCD	SqMtr	5			
11	VOLUME CONTROL DAMPER	SqMtr	2			
12	MOTORIZED FIRE DAMPER	SqMtr	2	Motorized Fire Damper excluding actuator with fire rating of 90min		
13	MOTORIZED ACTUATOR FOR FIRE DAMPER	No.	2	Actuators for fire damper with control panel		
14	NON RETURN DAMPER	SqMtr	5			
15	AIR INTAKE LOUVERS	SqMtr	6			
16	GRAVITY LOUVERS	SqMtr	5	For Exhaust Air		
17	AXIAL FLOW SUPPLY FANS - 4000 CMH	No.	2	Axial flow supply fans (wall mounted) with pre and fine filter complete with casing, TEFC sq cage induction motors & mounting frame, MS rain protection cowl, bird screen, gravity louvers, local push buttons and all other accessories as specified, fan shall have 30 mmwc static pressure.		
18	AXIAL FLOW EXHAUST FANS - 5000 CMH	No.	3	Axial flow exhaust fans (wall mounted) complete with casing, TEFC sq cage induction motors & mounting frame, MS rain protection cowl, bird screen, air intake louvers, local push buttons and all other accessories as specified, fan shall have 15 mmwc static pressure.		
19	AXIAL FLOW EXHAUST FANS - 6000 CMH	No.	4	Axial flow exhaust fans (wall mounted) complete with casing, TEFC sq cage induction motors & mounting frame, MS rain protection cowl, bird screen, air intake louvers, local push buttons and all other accessories as specified, fan shall have 15 mmwc static pressure.		
20	AXIAL FLOW EXHAUST FANS - 1000 CMH	No.	2	Axial flow exhaust fans (wall mounted) complete with casing, TEFC sq cage induction motors & mounting frame, MS rain protection cowl, bird screen, air intake louvers, local push buttons and all other accessories as specified, fan shall have 15 mmwc static pressure.		
21	STRUCTURE STEEL DUCT SUPPORT	MT	10	ISMC, ISMB, L angle structure		
22	SUPERVISION OF ERECTION TESTING AND COMMISSIONING FOR AIR CONDITIONING AND VENTILATION SYSTEM	Mandays	50	Supervision of Erection Testing & Commissioning for AC & ventilation System on per day basis for the days present at site on certification by BHEL site incharge. Price shall be inclusive of charges for lodging, boarding, medical, insurances etc.		
23	To & Fro travel charges	Visit	1	To & Fro travel charges on per visit basis for all visits as per site requirement. Local transportation between hotel and site to be arranged by contractor.		

	CLIENT – SJVN ARUN-III POWER DEVELOPMENT COMPANY (P) LTD. (SAPDC)	TB-405-553-001
	CONSULTANT- SJVN LTD.	Rev. 00
	PROJECT: 4x225MW ARUN-III, HYDRO ELECTRIC PROJECT, NEPAL TECHNICAL SPECIFICATION FOR AIR CONDITIONING & VENTILATION SYSTEM	Page 16

MANDATORY SPARES:

Sl. No.	Item Description	Unit	Qty.	Remarks	Unit Ex-Works	Total Ex-Works
1	PRE FILTERS	No.	4	4 sets of each used type		
2	FINE FILTERS	No.	4	4 sets of each used type		
3	V-Belts of each type for Centrifugal fans	Set	4	4 sets of each used type		
4	Blower Bearing Sets of each type for Centrifugal fans	Set	2			
5	AXIAL FLOW SUPPLY FANS - 4000 CMH	No.	2	Axial flow supply fans (wall mounted) with pre and fine filter complete with casing, TEFC sq cage induction motors & mounting frame, MS rain protection cowl, bird screen, gravity louvers, local push buttons and all other accessories as specified, fan shall have 30 mmwc static pressure		
6	AXIAL FLOW EXHAUST FANS - 5000 CMH	No.	1	Axial flow exhaust fans (wall mounted) complete with casing, TEFC sq cage induction motors & mounting frame, MS rain protection cowl, bird screen, air intake louvers, local push buttons and all other accessories as specified, fan shall have 15 mmwc static pressure		
7	AXIAL FLOW EXHAUST FANS - 6000 CMH	No.	1	Axial flow exhaust fans (wall mounted) complete with casing, TEFC sq cage induction motors & mounting frame, MS rain protection cowl, bird screen, air intake louvers, local push buttons and all other accessories as specified, fan shall have 15 mmwc static pressure		
8	AXIAL FLOW EXHAUST FANS - 1000 CMH	No.	1	Axial flow exhaust fans (wall mounted) complete with casing, TEFC sq cage induction motors & mounting frame, MS rain protection cowl, bird screen, air intake louvers, local push buttons and all other accessories as specified, fan shall have 15 mmwc static pressure		
9	SUPPLY AIR GRILL WITH VCD	SqMtr	1	10% of installed quantity		
10	VOLUME CONTROL DAMPER	SqMtr	1	10% of installed quantity		
11	MOTORIZED FIRE DAMPER	SqMtr	1	10% of installed quantity; Motorized Fire Damper excluding actuator with fire rating of 90min		
12	MOTORIZED ACTUATOR FOR FIRE DAMPER	No.	1	1 no. of each type used; Actuators for fire damper with control panel		
13	NON RETURN DAMPER	SqMtr	1	10% of installed quantity		
14	AIR INTAKE LOUVERS	SqMtr	1	10% of installed quantity		
15	GRAVITY LOUVERS	SqMtr	1	10% of installed quantity; For Exhaust Air		
16	Industrial type vacuum cleaner suitable for cleaning of filter banks of ventilation system	Set	1			
17	Power contactors and fuses	Set	1	10% of installed capacity		
18	Anemometer	No.	1			
19	Bearing heating devices suitable for replacement of bearing	Set	1	(preferably of induction type)		

	CLIENT – SJVN ARUN-III POWER DEVELOPMENT COMPANY (P) LTD. (SAPDC)	TB-405-553-001
	CONSULTANT- SJVN LTD.	Rev. 00
	PROJECT: 4x225MW ARUN-III, HYDRO ELECTRIC PROJECT, NEPAL TECHNICAL SPECIFICATION FOR AIR CONDITIONING & VENTILATION SYSTEM	Page 17

20	Bearing puller of suitable size for facilitating bearing replacement of coupling shaft etc.	Set	1	10% of installation		
----	---	-----	---	---------------------	--	--

**** Remarks: Bidder should go through the technical specification TB-405-553-001 Rev00 for detailing of all equipments.**

- a) The equipments and services to be furnished under this contract are detailed here under Cl. No. 1.11 of this section is for reference. Bidders shall work out the actual requirement based on the building & switchyard layout enclosed with this specification during detailed engineering stage.
- b) The Bill of Quantities shall be read in conjunction with the Instructions to Bidders, General and Special Conditions of Contract, Technical Specifications, and Drawings.
- c) The quantities given in the Bill of Quantities are estimated and provisional, and are given to provide a common basis for bidding. The basis of payment will be the actual quantities of work ordered and carried out, as measured by the Contractor and verified by the Purchaser and valued at the rates and prices bid in the priced Bill of Quantities.
- d) A rate or price shall be entered against each item in the priced Bill of Quantities. The cost of Items against which the Contractor has failed to enter a rate or price shall be deemed to be covered by other rates and prices entered in the Bill of Quantities.
- e) The whole cost of complying with the provisions of the Contract shall be included in the Items provided in the priced Bill of Quantities, and where no Items are provided, the cost shall be deemed to be distributed among the rates and prices entered for the related Items of Work.
- f) General directions and descriptions of work and materials are not necessarily repeated nor summarized in the Bill of Quantities. References to the relevant sections of the Contract documentation shall be made before entering prices against each item in the priced Bill of Quantities.
- g) **Miscellaneous items like hardware, fixtures, field instruments, insert plates, gusset plates, fittings etc. shall be deemed to be included under the relevant BOQ items and bidders shall consider the same while quoting for BOQ items.**
- h) Exact requirements shall be worked out during detailed engineering after award of contract.
- i) Bidders shall consider makes for various equipments as per Annexure A, which shall be subjected to Owner's approval during design engineering stage. Price implication to BHEL later on account of non-acceptance of proposed vendors by Owner shall not be considered.



CLIENT – SJVN ARUN-III POWER DEVELOPMENT COMPANY (P) LTD. (SAPDC)

CONSULTANT- SJVN LTD.

PROJECT: 4x225MW ARUN-III, HYDRO ELECTRIC PROJECT, NEPAL

TECHNICAL SPECIFICATION FOR AIR CONDITIONING & VENTILATION SYSTEM

TB-405-553-001

Rev. 00

Page | 18

Annexure-A

HVAC SYSTEM		
LIST OF MAKES OF SUB-VENDOR ITEMS-AS APPLICABLE (4x225 MW ARUN-3 HYDRO ELECTRIC PROJECT NEPAL)		
S.No.	Description	Makes
1.	CENTRIFUGAL FAN	FLAKT / KRUGGER / DRAFT AIR / HYDERABAD POLLUTION CONTROL / ADVANCE VENTILATION / PATEL AIR / NICOTRA/ SK SYSTEM / MARATHON / CB DOCTOR / SARLA
2.	AXIAL FLOW FANS/RE UNITS	HYDERABAD POLLUTION/ SK SYSTEM / ADVANCE VENTILATION / KRUGER / NICOTRA / MARATHON / FLAKT / CB DOCTOR/ PATEL AIR /SITAL
3.	SPLIT AIR CONDITIONER/ CASSETTE AC	VOLTAS / BLUE STAR / CARRIER / HITACHI / LG
4.	INDUCTION MOTORS (LT)	SIEMENS / ABB / CGL / MARATHON / KEC / BHARAT BIJLEE / NGEF /JYOTI / LHP
5.	AIR FILTER	PUROLATOR / FMI / ANFILCO / TENACITY / JOHN FOWLER /SPECTRUM / AIR TECH / PUROMATIC
6.	INSULTATION MATERIAL	BEARDSHELL / K-FLEX / PARAMONT/ ARMAFLEX / SUPREME / LLOYDS / UP TWIGA /AEROCELL
7.	FIRE DAMPER	TSC / CARRAIRE / RAVISTAR (SYSTEM AIR)
8.	STRIP HEATER	ESCORTS / RACOLD / DASPASS/ ALCO/ HEATCO / HOTSET
9.	PAN HUMIDIFIER	RAPID COOL/ HOTSET /ALCO
10.	BUTTERFLY VALVE	AUDCO / FOURESS / INTER VALVE / BDK / WEIR BDK / TYCO / CRANE PROCESS / KEYSTONE
11.	NON RETURN VALVE	LEADER / H.SARKAR / FLUID LINE / HI -TECH / CRESENT / A V VALVES / BANKIM & COMPANY / SHIVADURGA
12.	GATE/GLOBE VALVES	CRESENT / BDK / AUDCO / FOURESS / KIRLOSKAR / SANT / BOMBAY METAL & ALLOYS / BANKIM / LEADER / H SARKAR / AV VALVES / VENUS PUMPS AND ENGG
13.	RELIEF / PURGE VALVE	BRASSOMATIC
14.	PIPING - ERW	SURYA ROSHNI / TISCO / DADU PIPES / INDUS TUBE / WELSPUN / TATA / BST / JINDAL / SAIL
15.	GI SHEETS FOR DUCTING	TISCO / INDIAN IRON & STEEL CO LTD. / RASHITRYA ISPAT NIGAM LTD. / ESSAR/ ISPAT INDUSTRIES / JSW STEEL / LLOYDS STEEL / BHUSHAN / TATA / SAIL / JINDAL
16.	HUMID STAT	JHONSON CONTROL / HONEYWELL / PENN
17.	GRILLES/ DIFFUSERS/VOLUME CONTROL DAMPER	AIR FLOW/ TSC / AIR MASTER/ CARRAIRE / RAVI STAR (SYSTEM AIR)
18.	FLOW METER	EUREKA / INSTRUMENTATION ENGINEERS PVT LTD / PLACKA /TRAC / FLOW STAR/ SCIENTIFIC DEVICE
19.	RH SENSOR/TEMP SENSOR	HONEY WELL /JOHNSON /SIEMENS / GENERAL INSTRUMENTS
20.	PRESSURE GAUGE	GENERAL INST CONSORTIUM / BELL / H.GURU INST / WAAREE INSTRUMENTS / H. GURU IND / FORBES MARSHALL / MANOMETER / A.N. INST / GAUGES BOURDON / GLUCK / WIKA / ASHCROFT / BAUMER TECHNOLOGIES/PRECISION MASS PRODUCTS/ BOSE PANDA/ FIEBIG/ JAPSIN/ MICA
21.	THERMOSTATS	H.GURU/ FIEBIG/ JAPSIN/ MICA/ PENN/ HONEYWELL



CLIENT – SJVN ARUN-III POWER DEVELOPMENT COMPANY (P) LTD. (SAPDC)
 CONSULTANT- SJVN LTD.
 PROJECT: 4x225MW ARUN-III, HYDRO ELECTRIC PROJECT, NEPAL
 TECHNICAL SPECIFICATION FOR AIR CONDITIONING & VENTILATION SYSTEM

TB-405-553-001

Rev. 00

Page | 19

HVAC SYSTEM		
LIST OF MAKES OF SUB-VENDOR ITEMS-AS APPLICABLE (4x225 MW ARUN-3 HYDRO ELECTRIC PROJECT NEPAL)		
22.	TEMPERATURE GAUGE	H. GURU IND/ H.GURU INST/ FORBES MARSHALL/DETRIVE INST & ELECTRONICS / PYRO ELECTRIC /TOSHNIWAL BROSS / WAREE INSTRUMENTS / A.N.INST / GOA INSTRUMENTS / WIKA/ ASHCROFT / H GURU (SI)/ BAUMER TECHNOLOGIES/ GAUGE BOURDON/ GOA THERMOSTAT/ BUDENBERG GAUGE/ PRECISION MASS PRODUCTS
23.	LEVEL GAUGE	GENERAL INSTRUMENTS / CHEMTROLS / SBEM, PUNE/ AUTOMAT MUMBAI /SIGMA / TOSHNIWAL / TECHNOMATIC / TELACO/LEVCON / D K INSTRUMENTS / PUNE TECHTROL / FLOW STAR/ BLISS ANAND
24.	PRESSURE SWITCH / DP SWITCHES	BELLS / DANFOSS / DK INSTRUMENTS/ DRESSER / SOR INC / VASU / SWITZER / INDFOSS / TRAFAG / GIC / ASHCROFT/ KASTURBA UDYOG/ BARKSDALE/ PRECISION MASS/ MITTAL REFRIGERATION
25.	LEVEL SWITCH	SBEM / BLISS ANAND / HI TECH / RAMAN INST / SIGMA / SOR INC / WAREE INST / LEVCON / DK INSTURMENT / V AUTOMAT /CHEMTROLS / SIMENS / FLOW STAR / TRAC/ NIVO CONTROLS/ PUNE TECHTROLS/ SAPCON INSTRUMENTS/ BAUMER TECHNOLOGIES/ GIC
26.	ROTAMETER	CHEMTROLS SAMIL / EUREKA IND / IL / TRANSDUCERS AND CONTROL
27.	CONTROL PANEL	INDUSTRIAL CONTROL & APPLIANCE/ PYROTECH /POSITRONICS / CONTROL & SWITCHGEAR /SIEMENS / L&T /GE POWER /RITTAL / HOFFMAN
28.	FIBRE OPTIC CABLE	BIRLA ERICSON / FINOLEX / AKSH FIBRE
29.	LT ADAPTER BOX FOR AL TO CU CABLE CONVERTOR	CONTROL DEVICE / SYSTEM POWER CONTROL / JACKSON / UNILEC / ELECTRIC ALLIED PRODUCT
30.	ANNUNCIATOR FOR PANEL	ICC / PECON/ PROCON
NOTE		
		<p>1. THE SUB VENDOR LIST ABOVE IS INDICATIVE ONLY AND IS SUBJECT TO BHEL AND CUSTOMER APPROVAL DURING DETAILED ENGINEERING STAGE WITHOUT ANY COMMERCIAL & DELIVERY IMPLICATION TO BHEL. BIDDER TO PROPOSE SUB VENDOR WITHIN 4 WEEKS OF PLACEMENT OF LOI. THEREAFTER NO REQUEST FOR ADDITIONAL SUB-VENDOR SHALL BE ENTERTAINED.</p> <p>2. THE INSPECTION CATEGORY WILL BE INTIMATED AFTER AWARD OF CONTRACT BY BHEL/CUSTOMER. HOWEVER, THE SAME WILL BE ADHERED BY THE BIDDER WITHOUT ANY COMMERCIAL AND DELIVERY IMPLICATION TO BHEL/ CUSTOMER.</p>



CLIENT – SJVN ARUN-III POWER DEVELOPMENT COMPANY (P) LTD. (SAPDC)
 CONSULTANT- SJVN LTD.
 PROJECT: 4x225MW ARUN-III, HYDRO ELECTRIC PROJECT, NEPAL
 TECHNICAL SPECIFICATION FOR AIR CONDITIONING & VENTILATION SYSTEM

TB-405-553-001

Rev. 00

Page | 21

ANNEXURE-‘C’**Cable Sizes being procured by BHEL for Sub-Station****Control Cable**

Sno	Description
1	4cX6sq.mm Cu/HRPVC
2	4cX4sq.mm Cu/HRPVC
3	2CX2.5sq.mm Cu/HRPVC
4	5cX2.5sq.mm Cu/HRPVC
5	10cX2.5sq.mm Cu/HRPVC
6	14cX2.5sq.mm Cu/HRPVC
7	19cX2.5sq.mm Cu/HRPVC

Power Cable

Sno	Description
1	4CX4 mm ² Al/PVC
2	2CX6 mm ² Al/PVC
3	2Cx16 mm ² Al/PVC
4	4CX16 mm ² Al/PVC
5	3.5CX70 mm ² Al/PVC
6	3.5CX35 mm ² Al/PVC
7	3.5CX95 mm ² Al/PVC
8	1Cx70 Cu/XLPE
9	1CX400 mm ² Al/XLPE



CLIENT – SJVN ARUN-III POWER DEVELOPMENT COMPANY (P) LTD. (SAPDC)
 CONSULTANT- SJVN LTD.
 PROJECT: 4x225MW ARUN-III, HYDRO ELECTRIC PROJECT, NEPAL
 TECHNICAL SPECIFICATION FOR AIR CONDITIONING & VENTILATION SYSTEM

TB-405-553-001

Rev. 00

Page | 1

SECTION-2 CUSTOMER EQUIPMENT SPECIFICATION

2.1. SCOPE OF WORK

Scope of work under this section covers the provision of labour, tools, plants, materials and performance of work necessary for the design, engineering, manufacture, quality assurance, quality control, shop assembly, shop testing, packaging & delivery including insurance, unloading, site storage and preservation, in plant transportation at site, erection / installation, testing supervision, pre commissioning, successful commissioning, performance and acceptance testing, handing over and warrantee for two years of HVAC system, as per the specifications hereunder, each complete with all auxiliaries, accessories, spare parts and warranting a trouble free safe operation of the installation.

**Unloading, site storage and preservation, erection / installation, commissioning shall be in purchaser's scope.*

2.1.1. Detailed Scope of Work

The scope of work shall be a comprehensive functional system covering all supply and services including but not be limited to following:

2.1.1.1. Main equipment & auxiliaries

- i) Three Nos. ventilation blowers (2W+1S) each of capacity 50% of the total required air for GIS Building area.
- ii) One (1) lot of Split type/cassette type air conditioning units with all necessary auxiliaries of suitable capacity for Control Room Building for GIS Building area.
- iii) One (1) lot of Exhaust fan system, axial fan system for removal of foul air from GIS Building and Control Building area.
- iv) Air duct distribution system for supply air of all Ventilation systems as per the ventilation layout drawing, complete from blower room along with accessories for termination, with necessary galvanized sheet metal ducts.
- v) One (1) lot of motorized damper with manual override facility including damper control panel shall be provided in each ventilation blower system and each ventilation zone of the ventilated area. Control of motorized damper shall be automatic through fire panel and manual trough blower control panels.
- vi) Elbows, tees, supports, fixations, foundation plates including anti vibration pads, hangers, inserts, filters including all necessary grills, louvers, outside air louvers, adjusting duct dampers etc. to complete the ducting network.
- vii) Necessary fittings, insulation, cladding etc. required for air conditioning system.

2.1.1.2. Control, monitoring and related items and services

- i) Control panel for Air Blowers, exhaust system, motorized damper etc. complete with all necessary accessories.



CLIENT – SJVN ARUN-III POWER DEVELOPMENT COMPANY (P) LTD. (SAPDC)
 CONSULTANT- SJVN LTD.
 PROJECT: 4x225MW ARUN-III, HYDRO ELECTRIC PROJECT, NEPAL
 TECHNICAL SPECIFICATION FOR AIR CONDITIONING & VENTILATION SYSTEM

TB-405-553-001

Rev. 00

Page | 2

iii) Coordination and provision of necessary contacts and/ or ports for integration with plant SCADA system.

2.1.1.3. Common supplies and services

- i. Drawings, documents and design calculations
- ii. Shop, assembly, inspection & tests
- iii. Packaging, handling and site storage
- iv. Delivery, installation and commissioning
- v. Tools and instruments
- vi. Spare parts
- vii. Field/touch-up painting including all painting materials.

2.1.1.4. Completeness of System

Any other item(s) not mentioned specifically but necessary for the satisfactory completion of scope of work defined above, as per accepted standard(s)/best international practices.

2.2. STANDARDS & REGULATIONS

The design, manufacture and testing of the various equipment covered under this specification shall comply with the requirements of the latest edition of the relevant IEC/IS/IEEE/ISO standards only. Preference for latest IEC standards for particular equipment / system shall be governed over IEEE/ IS/ ISO standards. Further rules, guide lines and standard laid down by international/ national agency shall be applicable in this specification.

The relevant abstract (in soft / hard copy) of all referred standards shall be provided free of cost during engineering stage for facilitating review/ approval of submitted drawing/documents.

2.3. PARAMETERS & GUARANTEES

2.3.1. Specific Parameters and Layout Conditions

The GIS building area and control room area, shall be ventilated and air conditioned as detailed in this specification. The Fresh Air & Exhaust air fans shall be placed suitably. Split/ Cassette type ACs shall be distributed suitably as per the requirement in the GIS building area.

Ventilation System of GIS Hall:

Fresh air after being filtered is forced by the blower in supply air duct and is distributed in the GIS Hall through air ducts. The used air is exhausted through exhaust fans.

Air Conditioning System

The Air Conditioning System by split type / cassette type is to be provided at the following location of ARUN III HEP.

- i) Control Room in GIS Control Building area.
- ii) Offices in GIS Control Building area
- iii) Control & protection panel room in GIS Control Building area



CLIENT – SJVN ARUN-III POWER DEVELOPMENT COMPANY (P) LTD. (SAPDC)
 CONSULTANT- SJVN LTD.
 PROJECT: 4x225MW ARUN-III, HYDRO ELECTRIC PROJECT, NEPAL
 TECHNICAL SPECIFICATION FOR AIR CONDITIONING & VENTILATION SYSTEM

TB-405-553-001

Rev. 00

Page | 3

All unit shall be identical. The system shall be complete with all requisite control drain pipes, regenerating pipes. The system shall be capable of maintaining desired room temperature adjustable by thermostat which to be provided.

2.3.2. Rating and Functional Characteristics

Rating and functional characteristics of all the components of the HVAC system shall be of latest state of the art. If the system components mentioned in the awarded contract becomes obsolete at the time of approval of General technical particulars during detail engineering, the Contractor shall offer the latest model without any extra cost to purchaser. The system design shall be based on criteria, factors, and details recommended as specified in national / international standards / handbooks such as ASHRAE handbook.

2.3.2.1. Ventilation areas and Air changes per hour

All ventilated and air conditioned area shall be designed to maintain a positive pressure within the designated areas as defined above. For all ventilated and air conditioned rooms the air changes shall be as per latest edition of IS 4720. The dimensions of the various areas are as shown in the layout drawings.

2.3.2.2. Noise levels

The noise level when measured at 1.5 m from source, caused by operation of the VENTILATION & AIR CONDITIONING systems shall be as per relevant standards. Silencer, as required, shall be provided to guarantee the sound levels.

2.3.2.3. Maximum air velocities in ducts

In main ducts: 11 m/s

In branch ducts: 8 m/s

2.3.3. Performance Criteria and Guarantee

The HVAC system along with all auxiliaries and accessories shall be capable of performing intended duties under specified conditions It is the responsibility of the Contractor to supply the equipment as per relevant standards and shall also guarantee the reliability and performance for the same to meet the provisions of contract.

2.3.4. Power supply arrangement

The Contractor shall design HVAC control system based on 240V AC UPS or 220V DC supply. However, if the offered equipment is operating at different voltage level, the Contractor shall provide all required hardware to make the offered system compatible with specified power supply arrangement.



CLIENT – SJVN ARUN-III POWER DEVELOPMENT COMPANY (P) LTD. (SAPDC)
 CONSULTANT- SJVN LTD.
 PROJECT: 4x225MW ARUN-III, HYDRO ELECTRIC PROJECT, NEPAL
 TECHNICAL SPECIFICATION FOR AIR CONDITIONING & VENTILATION SYSTEM

TB-405-553-001

Rev. 00

Page | 4

2.4. DESIGN AND CONSTRUCTION

2.4.1. Ventilation System

2.4.1.1. Electric Fans

1. General

The capacities of the fresh air blowers shall be worked out on the basis of air changes per hour. The blowers shall be installed in the blower room.

2. Design

The fans shall be designed to comply with the maximum noise levels as specified. The fans shall be resistant to the moisture. The fan shall be designed for optimum performance at a given duty however; it should be capable of working over a range of pressure and volume. The fans should be designed for the static pressures suitable for site conditions.

The casing of the blowers shall be welded construction, fabricated with heavy gauge material. It shall be rigidly reinforced and supported by structural angles and seams shall be permanently sealed air tight. The impeller, pulley and shaft sleeves shall be secured to the shaft by keys and nuts. The impeller shall be statically and dynamically balanced. The bearings may be ball, roller or sleeve and shall be adequately supported. They shall be easily accessible and properly lubricated. Inlet for air shall have a smooth contour. The blower dampers at the plenums shall be electrically operated and the openings and closings of these dampers shall be automatically /manually switch operated with the starting of the blowers. The blower shall be provided with anti-vibration pads at the bottom.

2.4.1.2. Induction Motors (General Purpose)

Blower motors shall be totally enclosed type and shall be to latest standard. The motors shall be suitable for operation at 415 Volts and 50 C/S, three phase supply with variation as given below:-

Variation of supply voltage from rated motor voltage: $\pm 10\%$

Variation of supply frequency from rated frequency: $\pm 3\%$

The motors shall be provided with anti-vibration pads at the bottom.

All electric motors for driving various equipment shall conform to relevant standards viz. IEC, BS or IS as applicable.

The motor rating, torque characteristics, speed etc. shall be selected to suit the duty requirements.

Type of starter for motors shall be duly approved by the purchaser during detailed engineering. The detailed design calculation for selection of type of starters is to be submitted for approval. The priority for type of starters shall be in the following order:

1. Variable frequency drive
2. Soft starter
3. Star delta/ auto –transformer
4. Direct on-line starter



CLIENT – SJVN ARUN-III POWER DEVELOPMENT COMPANY (P) LTD. (SAPDC)
 CONSULTANT- SJVN LTD.
 PROJECT: 4x225MW ARUN-III, HYDRO ELECTRIC PROJECT, NEPAL
 TECHNICAL SPECIFICATION FOR AIR CONDITIONING & VENTILATION SYSTEM

TB-405-553-001

Rev. 00

Page | 5

The enclosure of each motor shall be of the type best suited for the service conditions of the motor.

The motor insulation shall be resistant to moisture, oil or oil vapor and the motors in general shall be so designed as to suit the tropical climate. Varnished cambric or glass insulation class F shall be used for connection from the windings to the terminals.

The terminal box shall be closed conduit box type conveniently located, and shall have means for terminating the external wiring for outdoor use. The motor terminals shall be of the stud type totally enclosed. Eye bolts or lugs shall be provided for lifting.

Space heaters to avoid condensation shall also be provided.

2.4.1.3. Filters

Filters shall consist of V fold galvanized wire mesh inter spaced with a flat layer of galvanized wire mesh. The density of the filter medium shall increase in the direction of air flow. Wire mesh edges shall be suitably hemmed to eliminate danger of abrasion during handling. Filter media shall be supported on either side by galvanized expanded metal casing. Filter frame shall be fabricated from aluminum alloy of minimum 16gauge thickness conforming to IS: 737 or 18 gauge GI sheets. The filter shall be dry type. The filter must be capable of being completely cleaned of their accumulated dust by flushing with tap water.

2.4.2. AIR CONDITIONING SYSTEM

Air conditioning system in the designated area as specified above shall be designed by using Split type/cassette type air conditioning units with all necessary auxiliaries of suitable capacity suitable for control area. To be finalized during detailed engineering based on the final layout. Contractor shall coordinate with the civil & architecture group for finalizing the size, color, type matching with the ceiling color / alignment etc.

Necessary piping, valves, fittings, insulation, cladding etc. required for air conditioning system shall be part of the scope. Contractor shall coordinate with civil group for the drainage upto the drain point.

Power supply receptacles at strategic location shall be cover under illumination package. However, connection cable from AC to receptacles including plug top shall be supplied by the contractor.

2.4.3. Description of Control Panels

Panels shall be provided at different locations for supply and control of different motors for blowers, and motorized dampers, etc. Panel shall include necessary relay, push buttons, indicating lamps and electronic display unit for voltage, current, kW and power factor and electronic energy meter at incomer feeder.

Provision for display of flow rate (m³/hr) shall also be made in the control panel of ventilation / booster blower system panel.

2.4.4. Exhaust Fans

The design and construction of the exhaust fans shall comply with latest standards. Exhaust air fans shall be adjustable axial flow fans. Axial air fans shall be of the multi blade vane type. The vanes shall be adjustable individually at standstill. The hub of the impeller shall be directly coupled to the motor shaft and its diameter adapted to the motor frame. The impeller shall be statically and dynamically balanced. The exhaust fans shall be placed at a suitable location for easy maintenance.



CLIENT – SJVN ARUN-III POWER DEVELOPMENT COMPANY (P) LTD. (SAPDC)
 CONSULTANT- SJVN LTD.
 PROJECT: 4x225MW ARUN-III, HYDRO ELECTRIC PROJECT, NEPAL
 TECHNICAL SPECIFICATION FOR AIR CONDITIONING & VENTILATION SYSTEM

TB-405-553-001

Rev. 00

Page | 6

All bearings shall be pre-lubricated, self-aligning and selected for a trouble free operation. If, however, frequent lubrication is required this should be possible from the outside of the fan casing without disturbing the fan duct assembly, Bearings supports shall be specially designed for trouble-free bearing service. All fan shafts and wheels shall be designed to operate at their maximum rated speed. Anti-vibration mountings shall be provided for each fan for minimum noise level.

2.5. AUXILIARY SYSTEM AND MISCELLANEOUS COMPONENTS

2.5.1. Material Requirements for duct construction

1. The rolled steel sheet before galvanizing shall be properly annealed or normalized so as to allow fabrication of ducts without developing cracks and zinc coating on the steel shall not be less than 275 gms/m Class IV as per IS-277-1969 or latest revised.
2. The thickness of steel sheets, type of bracings and other construction and fabrication details shall be in accordance with IS 655 of latest version. The ducts shall be swedged 40mm from the ends so that the larger and will butt against the swedge and are held in place with sheet metal screws. Where the swedges are not used, the joints shall be pasted with asbestos paper to ensure a tight joint. The galvanized steel sheet ducting shall be fabricated at site with latest mechanized method from various sections of the duct.

2.5.2. Dampers

1. Dampers shall be placed at all suitable points for proportional volume control of the system. Dampers shall be made of 18 gauge GSS of quadrant type with suitable locking device mounted outside of duct in an accessible location.
2. Motorized fire dampers or fire doors shall be provided in main ventilation blower and each ventilation zone. Same shall be finalized during detailed engineering. Motorized fire dampers shall be actuated automatically through fire protection panel and manually from the damper control panel.

2.5.3. Plenums

All the plenum chambers or connections to fans, dampers etc. shall be supported on suitable angle frames of GSS.

2.5.4. Grilles

The type and the quantity of grilles required shall be worked out by the Contractor. The Contractor shall ensure that the grilles offered are of requisite capacity, throw and terminal velocity. The grilles shall have facility of controlling air flow. Contractor shall coordinate with the civil architecture group for finalizing the size, color, type matching with the ceiling color / alignment etc.

2.5.5. Outside Air Louvers

Outside air louvers of each of the fresh air and exhaust air system shall prevent the entrance of rain, insects, birds and trash into the ducts. They shall be stamped and pressed out of one piece of aluminum sheet of at least 2mm thickness. The frames shall also be made of aluminum.



CLIENT – SJVN ARUN-III POWER DEVELOPMENT COMPANY (P) LTD. (SAPDC)
 CONSULTANT- SJVN LTD.
 PROJECT: 4x225MW ARUN-III, HYDRO ELECTRIC PROJECT, NEPAL
 TECHNICAL SPECIFICATION FOR AIR CONDITIONING & VENTILATION SYSTEM

TB-405-553-001

Rev. 00

Page | 7

2.5.6. Balancing

1. The air distribution system shall be tested/ balanced by Contractor so that the air flow is maintained throughout the space to be ventilated.
2. All instruments required for testing/balancing the air distribution system shall be provided by the Contractor.

2.5.7. Piping System

The necessary piping installation for Air conditioning system shall be the part of supply.

2.6. Drawings, Documents and Design Calculations

After award of contract, the contractor shall furnish all drawings, documents, design calculations, data, manuals & other necessary literature, pertaining to equipment offered by them & so specified under various clauses. Bidder shall submit Ten (10) number hard copies of the documents & drawings to customer for reference / review / approval. A comprehensive list of all such drawings/documents planned to be submitted for reference/approval shall be provided beforehand for approval of the customer. The list of drawings & documents to be furnished for approval / reference shall not be limited to the following:-

- i) Drawings, documents, design calculations literatures, manuals etc.
- iii) Detailed quality assurance plan, giving complete specifications of the materials and specifications relating to inspection and testing of materials and finished components.
- iv) All drawings having bearing on civil foundations, equipment foundation details and loads
- v) Arrangement, installation, foundation, plan, section, detailing of main equipment and sub-assemblies including piping, control & instrumentation system.
- vi) All Electrical, Hydraulic & Control Drawings such as Electrical Panels OGA, Cable Block & Termination Diagram, Schematic Diagram, JB/MB/Kiosk Diagram etc. in respect of this section.
- vii) All manufacturing drawings not specifically covered under approval/reference category shall be submitted for record and facilitate inspection of the component in the shop and assembly at site.

Any other drawings, documents, design calculations, literatures, manuals etc. not covered anywhere in the specification, but required to be furnished for approval / reference of employer for suitability of design to fulfill the scope of work.

2.7. SHOP ASSEMBLY, INSPECTION AND TESTS

2.7.1. Type test

The list of type test is given below:

- a) Blower fans and associated motors
 - i. High voltage
 - ii. Insulation resistance
 - iii. Earthing continuity
 - iv. Electrical Power



CLIENT – SJVN ARUN-III POWER DEVELOPMENT COMPANY (P) LTD. (SAPDC)
 CONSULTANT- SJVN LTD.
 PROJECT: 4x225MW ARUN-III, HYDRO ELECTRIC PROJECT, NEPAL
 TECHNICAL SPECIFICATION FOR AIR CONDITIONING & VENTILATION SYSTEM

TB-405-553-001

Rev. 00

Page | 8

- v. Fan speed
- vi. Power factor
- vii. Leakage current
- viii. Starting
- ix. Test for capacitor
- x. Air delivery
- xi. Temperature rise
- xii. Characteristic curve of ventilation, exhaust & blower

2.7.2. Routine tests

Routine tests on all the types of motors, fans, Air Conditioner, filters, grilles, louvers, dampers, pipes, ducting coils, valves, V belts, pulley, coupling shaft, fan impeller shaft, bearings and fittings shall be conducted as per relevant standards.

2.7.3. Field tests

2.7.3.1. Test during installation and pre commissioning

At least following tests shall be conducted during installation and pre commissioning:

- i) Dielectric and insulation resistance on all electrical circuits
- ii) Tests to verify electrical ratings
- iii) Functional tests on panels
- iv) Checking of various sizes of ducts (dimensional checks)
- v) Fixing of ducts supports as per drawing.

2.7.3.2. Commissioning tests

At least following tests shall be conducted during commissioning:

- i) General running test
- ii) Leakage test
- iii) Checking of air velocity at different locations
- iv) Checking for abnormal noise and vibration
- v) Capacity rating test
- vi) Power consumption test
- vii) Functional test of Air Conditioner in respect of temperature and humidity.

2.7.4. Performance Testing

After completion of commissioning tests and commissioning of complete system (ventilation and air conditioning), the test service period of thirty (30) days shall follow before taking over. During this test service period, the system / installations must perform satisfactorily & if any defects are observed, same shall be rectified by contractor without any financial implication to employer.

2.8. SITE INSTALLATION AND COMMISSIONING

2.8.1. General

The Contractor has to do all the work related to supervision of assembly, erection, testing and commissioning complete in all respects. All necessary tools, plants, labour materials including consumables for performing installation, testing and pre-commissioning shall be provided by the Contractor.



CLIENT – SJVN ARUN-III POWER DEVELOPMENT COMPANY (P) LTD. (SAPDC)
 CONSULTANT- SJVN LTD.
 PROJECT: 4x225MW ARUN-III, HYDRO ELECTRIC PROJECT, NEPAL
 TECHNICAL SPECIFICATION FOR AIR CONDITIONING & VENTILATION SYSTEM

TB-405-553-001

Rev. 00

Page | 9

The Contractor shall supply sufficient number of erection and commissioning spare based on their experience so that erection, testing and commissioning work progresses smoothly and is not hampered for want of such spares. These spares shall be in addition to the spare arts described under clause “Spare Parts”.

2.9. SPARE PARTS

The spare parts mentioned here under are meant for use by the Employer during operation and maintenance stage and shall not be used as erection spares required during installation.

2.9.1. Mandatory Spare Parts

The Contractor shall supply the mandatory spare parts as per clause 1.4 of Section-1.

2.9.2. Recommended Spare Parts

The Contractor shall furnish the list of recommended spare parts at Schedule-4 of Section-5.



SECTION- 3

PROJECT DETAILS AND GENERAL SPECIFICATIONS

3.0 GENERAL

This section stipulates the General Technical Requirements under the Contract and will form an integral part of the Technical Specification.

The provisions under this section are intended to supplement general requirements for the materials, equipment and services covered under other sections of tender documents and are not exclusive. However, in case of conflict between the requirements specified in this section and requirements specified under other sections, the requirements specified under respective sections shall prevail.

3.1 PROJECT DETAILS

Name of the Project:	4x225MW , Arun-3 HEP ,Nepal
Name of the Customer:	SAPDC
Name of Consultant :	SJVN

SJVN Arun-3 Power Development Company (P) Ltd. (SAPDC), a company promoted by SJVN Ltd., as a single shareholder company in Nepal having its registered office at Lokanthali, Kathmandu, Nepal has signed Project Development Agreement with Government of Nepal to plan, promote, organize & execute Arun-3 Hydroelectric Project (900 MW) in Sankhwasabha District. of Nepal.

The bid prepared by the Bidder and all correspondence and documents related to the bid exchanged by the Bidder and the consultant/owner shall be written in the English, provided that any printed literature furnished by the Bidder may be written in another language, as long as such literature is accompanied by a translation in English, in which case, for purposes of interpretation of the bid, the translation shall govern.

3.2 Location & Land Availability:

The proposed project site is located at a distance of 50 km from Khandbari, the headquarters of Sankhuwa sabha District of Nepal. It is at about 240 km from Biratnagar and about 740 km from Kathmandu. The location details of the proposed project site are as indicated below:

- Latitude 27°30'N – 27° -35'N
- Longitude 87° -12'E – 88°-20'E
- Distance from Tumlingtar (domestic airport) town is.....About 68 km
- Distance of Kathmandu (international airport) from Tumlingtar.....About 660.km

3.3 Climatic Condition

Average max temp: 30° C

Average Minimum Temp: 20° C

Maximum river water temperature: 25°C



Minimum river water temperature: 10°C

Ambient Temperature for the Equipment: 40° C

3.4 Seismic Zone

The equipment shall be designed for operation in seismic zone IV for earthquake resistance. The equipment and each part of it shall be strong enough and sufficiently well connected to resist total operating stresses resulting from forces in normal operation, abnormal condition and forces superimposed due to occurrence of earthquakes of intensity which cause a ground acceleration of 0.16 g in vertical direction and 0.24 g in the other horizontal directions.

3.5 Transportation

Unless otherwise specified in the **Specification**, responsibility for arranging transportation of plant and equipment lies with the Contractor. The Contractor shall at its own risk and expense transport all plant and equipment to a destination specified in bid document. The contractor shall transport the contracted plant and equipment/ supplies through registered common carriers only.

The nearest major airport is at Kathmandu which is at a distance of 740km from Project Site Biratnagar is connected to Kathmandu by Road.

The major nearest seaport for the trans-shipment of heavy equipment to Nepal is Kolkata.

Other sea ports for imported equipment would be Mumbai or Chennai as convenient. The two sea ports Mumbai & Chennai are connected to Kolkata and Jogbani by rail as well as roads.

Railway transport is available from Kolkata and other locations of Indian Cities to the Nepal-India border only. The broad gauge line from Kolkata ends at Jogbani, Bihar. All rail freight for Nepal has to be unloaded there. The distance of Kolkata by rail route is about 800 km. From Jogbani, the road distance to the projects sites via Biratnagar is about 300km.

Road access to Arun-3 project from Kolkata to Jogbani is 600km; from Biratnagar to Project Area via Hile is 300km. Total distance to project area from Kolkata is 900km. Alternative route could be from Kolkata to Raxaul which is 800km, further from Birganj to Dhalkebar to Hile to Project Area which is 450km. Total distance Kolkata to Project Area is 1250km.

Local transportation, insurance and other services incidental to the delivery of facilities to be supplied from Employer's country (Schedule- 2 Items) shall be quoted separately.

3.6 Transport Limitation

The transport limitation by road from Jogbani to the project site is the governing factor for determining permissible package size and weight.

The existing roads allow the transport of the packages of the following size and weight. Size (in mm) (l x b x h) - 9700 x 6000 x 6000*

Weight (Tonnes) - 70R

Heaviest package to be transported with suitable number of axle for safe transportation of consignment for 70R bridge capacity.

* Height from the ground.



3.7 Salient features of Project

The salient features of Arun-3 HEP are as follows:

A. POWER HOUSE COMPLEX

- | | |
|-------------------------------|------------------------------------|
| i. Power House Cavern | Underground on Left bank |
| ii. Installed capacity | 900 MW |
| iii. No. of units | 4 |
| iv. Unit Capacity | 225 MW |
| v. Size of Power House Cavern | 179.50m (L) x 22.5m (W) x 49.5m(H) |

B. UNDERGROUND TRANSFORMER CAVERN

- | | |
|----------------------------|---|
| i. Size | 146.14m (L) x 16 m(W)x 23m(H) |
| ii. Transformer Type | Single Phase |
| iii. Number and rating | 13 nos. (including 1 spare),
15.75/420/ $\sqrt{3}$ kV, 50Hz, 92MVA |
| iv. Transformer Hall level | El. 552 m |

C. Switchyard & Transmission

- | | |
|-------------------------|---|
| i. Type of Switching | Gas Insulated Substation and Pothead Yard |
| ii. Size | 207m (L) x 106m (W) |
| iii. Switchyard level | El. 557 m |
| iv. Transmission System | 400kV Arun III HEP – Muzzafarpur via
Dhalkebar D/c Quad Moose
Lines with LILO of both circuits at
Dhalkebar 400/220kV substation |

3.7.1 SYSTEM PARAMETERS

1	Continuous current carrying capacity (rms) at 40° C ambient temperature.	2000A (min)
2	Short time current carrying Capacity	50kA for 1sec
3	Voltage	400KV/420kV (rms) (Nom/Max)
4	Frequency	50Hz
5	System neutral earthing	Effectively earthed
6	Insulation Level	
a	One minute Dry Power frequency Withstand Voltage (kV rms)	630
b	One minute Wet power frequency Withstand Voltage (rms)	630
7	Switching Impulse withstand(250/2500 microsec.) voltage (kV peak)	1050
8	Impulse Withstand Voltage of arrester housing with 1.2/50 micro sec wave.	1425 kVp
9	Creepage distance	25 (mm/kV)
10	Radio Interference voltage at 320kV	As per CEA guidelines



3.7.2 AUXILIARY POWER SUPPLY

3.7.2.1 AC power

Three-phase system with grounded neutral for feeding three-phase and one-phase consumers (connected between phase and neutral), 415/240V \pm 10% and 50Hz, -5% to +3 %. All motors and other electrical apparatus should be designed to work continuously under, -5% to +3 % frequency variation and \pm 10% voltage variation.

3.7.2.2 DC power

DC Systems, ungrounded, with earth fault detection 220V plus (+) 10% and minus (-) 20% for the supply of main control circuits for high and medium voltage switchgear, protection circuits and to other larger essentials loads. Other voltage systems eventually needed, shall be generated from the above systems by means of dc/dc converters, inverters etc.

3.7.2.3 Deleted

3.7.2.4 Cabling & wiring

Wiring within cubicles and equipment enclosures shall conform to requirements of this section unless otherwise specified. Control wiring shall be single / stranded copper subjected to prior approval by purchaser during detailed engineering and shall not be smaller than 2.5 Sq. mm, except as otherwise agreed by the purchaser.

All Distribution Boards, Control & Protection panels, Motor Control control panels etc. shall be supplied completely wired internally up to the terminal blocks ready to receive purchaser control cable.

All inter cubicle and inter panel wiring and connections between panels of same Distribution Board, Control & Protection panels, Motor Control panels including all bus wiring for AC and DC supplies shall be provided by the tenderer.

Larger size wiring shall be used where needed for the current carrying capacity requirements.

Cables shall have at least 1000 V PVC insulation except for 220V DC and telemetering or communication system equipment for which 650V and 300 V ratings respectively are acceptable.

For current and potential transformer secondary circuits the minimum cross section of the conductors shall not be less than 4.0 Sq. mm.

Wiring shall terminate at terminal blocks at one side only. Where tap connections are required, they shall be made on terminal blocks. Wiring shall be neatly arranged and laid in wire ways accessible from the front door.

Engraved core identification ferrules marked to correspond with panel wiring diagram shall be fitted at both ends of each wire.

Each cubical shall be provided with an earthing bar (PE) of sufficient cross section carrying any possible fault current without undue heating. All metallic parts of the cubicle not forming part of the live circuits, all instrument transformer terminals to be earthed and other earthing terminals as well as all cable screens and PE-wires shall be connected to the earthing bar.



3.7.2.5 Power outlets

Power outlet for utilities such as electric drills, welding equipment etc., shall be provided in all floors of the powerhouse to enable repair and maintenance works to be done locally/ in-situ.

3.7.2.6 Terminal blocks

The terminal blocks shall be located to allow a neat and easy connection work and shall be safely accessible while the equipment is in service. Control circuits and power circuits shall be completely separated by use of divided or separate terminal blocks. Power terminal blocks shall be rated in accordance with applicable standards, and shall be provided with covers.

Terminal blocks shall be 1100V grade and have continuous rating to carry the maximum expected current on the terminals.

Terminal blocks for current transformer and voltage transformer secondary leads shall be provided with test links and isolating facilities. The current transformer secondary leads shall also be provided with short circuiting and earthing facilities.

The terminal shall be such that maximum contact area is achieved when a cable is terminated. The terminal shall have a locking characteristic to prevent cable from escaping from the terminal clamp unless it is done intentionally.

The conducting part in contact with cable shall preferably be tinned or silver plated.

The terminal blocks shall be of extensible design. The terminal blocks shall have locking arrangement to prevent its escape from the mounting rails.

The terminal blocks shall be fully enclosed with removable covers of transparent, non-deteriorating type plastic material. Insulating barriers shall be provided between the terminal blocks. These barriers shall not hinder the operator from carrying out the wiring without removing the barriers.

Unless otherwise specified terminal blocks shall be suitable for connecting the following conductors on each side.

All circuits except CT/ PT flexible circuits	Minimum of two of 2.5 sq. mm copper
All CT/ PT Circuits flexible	Minimum of 2 nos. of 6 sq. mm copper

The arrangements shall be made in such a manner so that it is possible to safely connect or disconnect terminals on live circuits and replace fuse links when the cabinet is live.

Wherever duplication of a terminal block is necessary it shall be achieved by solid bonding links.

At least 20% spare terminals shall be provided on each panel / cubicle / box and these spare terminals shall be uniformly distributed on all terminals rows.



There shall be minimum clearance of 250 mm between the first / bottom row of terminal block and the associated cable gland plate. Also, the clearance between two rows of terminal blocks shall be a minimum of 150 mm.

3.7.2.7 Protection requirement

For short circuit and overload protection of power and control circuits, air circuit breakers, moulded case circuit breakers or MCBs shall be used. Outlets from AC (and DC) distribution panels are protected in their respective panels.

3.7.2.8 Switches, Lamps & Instruments

General

Control switches, indicating lamps and instruments shall be arranged so that all parts are readily accessible for servicing without the necessity to remove other devices, terminal blocks or excessive amount of wiring.

All control switches and indicating devices mounted in cabinets and enclosures shall be visible with the doors closed.

Identification nameplates shall be provided for all control switches, indicating instruments and lamps, in accordance with clause "Nameplates".

Instruments and controls shall be located so that their dials, indicators and nameplates are clearly readable. Data for all instruments to be provided, including type, size, scale range, electrical ratings, nameplate and name of manufacturer, shall be furnished. Steel panels shall be provided for group mounting of the instruments.

All instruments shall be of an approved type and shall match, insofar as practicable, the other instruments with which they are associated; their dial type, scaled markings and units, type of connection and mounting, shall be co-coordinated. All piping and tubing required for instruments shall be furnished and installed. All instruments and control switches shall be furnished with necessary auxiliaries, i.e. resistors, shunts etc.

3.7.2.9 Control and Selector switches

The switches and push buttons shall be provided with ample contact ratings, suitable cam or block arrangements necessary for the control functions on 230 V AC or 220V DC circuits. The control switches used in mimic diagrams shall be of discrepancy type with built in lamp indication.

Control and Selector switches shall be rotary type with escutcheon plates clearly marked to show the function and positions. The switches shall be of sturdy construction suitable for mounting on panel front.

Switches with shrouding of live parts and sealing of contacts against dust ingress shall be provided.

Circuit breaker control switches shall have three positions and shall be spring return to "NEUTRAL" from "CLOSE" and "TRIP" positions and shall have pistol grip handles. They shall have at least two (2) contacts closing in close position, and two (2) contacts closing in trip position unless specified otherwise.



Ammeter and voltmeter selector switches shall have four stay out position with adequate number of contacts for three phase 4 wire system. These shall have oval handles. Ammeter selector switches shall have make before break type contacts to prevent open circuiting of CT secondaries. Contacts of the switches shall be spring assisted and shall be of suitable material to give a long trouble free service.

3.7.2.10 Push buttons

Push-buttons shall be of spring return, push to actuate type. Their contacts shall be rated to make, continuously carry and break 10A at 230V AC and 0.5A at 220V DC.

All push buttons shall have one normally open and one normally closed contact, unless specified otherwise. The contact faces shall be of silver or silver alloy.

All push buttons shall be provided with integral escutcheon plates marked with its function. The colour of the button shall be as follows:

- Green : Breaker Close
- Red : Breaker Open
- Black : For overload reset

3.7.2.11 Indicating and signaling lamps

Each indicating and signaling lamp shall have a removable cap, which can be inscribed with wording and shall not be affected with the heat of the lamp.

Indicating lamps are preferably of LED type & low watt consumption and shall be replaceable from the front of the panel. The indicating and signaling lamps shall be of the same size and type.

Lamps shall be provided with series resistors, preferably built-in the lamps assembly.

The lamps shall have escutcheon plates marked with its function, wherever necessary.

Lamps shall have translucent lamp-covers of the following colours, as warranted by the application.

- Red : ACB's/MCCB's close
- Green : ACB's/MCCB's open
- White : Auto trip
- Amber : For all healthy conditions e.g. control supply
- Voilet : Circuit breaker spring charged
- Blue : For all alarm conditions (e.g. overload) Also for "SERVICE" & "TEST" positions indicators

Indication lamps should be located just above the associated push buttons/control switches. All indicating lamps shall be suitable for continuous operation at 90% to 110% of their rated voltage.

3.7.2.12 HRC Fuses

HRC-Fuses shall have visible operation indicators.

HRC-Fuses shall be mounted on fuses carriers, which are mounted on fuse bases. Wherever it is not possible to mount fuses on carriers, fuses shall be directly mounted on plug-in type of bases. In such cases one set of insulated fuse pulling handles shall be supplied with each switchgear.



HRC-Fuse rating shall be chosen by the tenderer depending upon the circuit requirements.

3.7.2.13 Indicating instruments and Meters

Instruments mounted on panels, shall be of the semi flush type back connected, matching pattern, shape, and of approved finish to present neat and fitting appearance consistent with functional requirements Mechanical quantity measuring instruments which are directly mounted on equipment shall have circular dials and shall be properly supported and guarded against accidental injury/breakage. These shall be placed in convenient locations.

The instruments shall accurately measure and indicate the quantity under all conditions of operation with minimum instrument errors. Changes in ambient temperature within the range prevailing at site shall not affect the accuracy Contact making instruments shall have contacts suitable for 240 V AC or 220 V DC circuits.

The reading scales on the dials shall be in metric units only and range shall be such that the normal operating values of the quantities are indicated in the middle 3rd of the scale. The dials pointer etc. shall be designed to facilitate accurate reading by minimizing parallax and glare from instrument window and by providing clear bold dial markings. The size of dial and length of the scales of the indicating instruments shall be large enough to suit the requirements. The scale plates of panel mounted indicating instruments shall have a permanent white mat finish with black graduations and the pointer shall also be of the black colour. Instruments mounted on panels shall be of flush type and shall be back connected. All instruments on a switchgear panel shall be of matching pattern, shape and finish so as to present a pleasing appearance consistent with the functional requirements.

All instruments shall conform to relevant International or national applicable standards. These shall be subjected to tests prior to dispatch. The instruments shall be shock, vibration and moisture proof. The electrical instruments shall withstand dielectric test of 2000 V RMS to ground for one (1) minute as per standards.

The coils of electrical instruments shall be designed for continuous operation at 110% of the full load current at instrument potential. The coil rating of the measuring instruments shall be coordinated with those of the associated instrument transformers (i.e. CTs, PTs, etc.) by the supplier. The VA burden of the instruments shall be as low as possible. The meters shall be of the first grade in respect of accuracy classification.

Energy meter shall be suitable for 3-phase, 4-wire unbalanced system and shall comply generally with the relevant standard. All instruments shall be tested in accordance with the requirements of relevant standards.

3.7.2.14 Integrating instruments

The Wh and VARh meters shall be of the semi-flush-mounted type. Each meter shall be connected to terminal blocks suitable for opening and short-circuiting for testing purposes. The meter cases shall be dust-tight and with removable covers. The meters shall be three-phase, three element, equipped with an impulse contact mechanism, potential free for remote metering purposes, and shall be suitable for continuous operation from secondary of potential transformers and from secondary of current transformers, with transformer ratios and connections indicated on the contract drawings.



The meters shall be provided with primary-rated, direct reading registers, with five or more digits and a suitable multiplier. The meters for the outgoing lines shall be of the two-way type and all meters shall have mechanism to prevent negative registration.

The meters shall have built in over-voltage protection and isolation according to IEC Publication 60521. The tolerance ambient temperature range of the meters shall be 0 to 45 degrees C.

The protection class of the Wh meters shall be 0.2 and the VARh meters 0.2 according to IEC Publication 60687.

3.7.2.15 Measuring converters

The converters shall be suitable for direct connection to the secondary circuits of the potential and current transformers used, or other sensors, each as they apply. The converters shall be static type, having all accessories to provide an output signal of 4-20 mA, filtered DC.

For the measuring converters the following minimum requirements shall be fulfilled:

Current transducers shall be single-phase, of accuracy class 0.5 or better. Voltage transducers shall be single-phase of accuracy class 0.5 or better. W and VAR transducers shall be two elements, three-phase. Accuracy class of the transducers shall be 0.5 or better.

3.7.2.16 Measuring transformers

All current and voltage transformers shall be completely encapsulated cast resin insulated type suitable for continuous operation at the temperature prevailing inside the switchgear enclosure, when the distribution board is operating at its rated condition and the outside ambient temperature is 40 deg.C.

All instrument transformers shall be able to withstand the thermal and mechanical stresses resulting from the maximum short circuit and momentary current ratings of the associated switchgear.

All instrument transformer shall have clear indelible polarity markings. All secondary terminals shall be wired to a separate terminal on an accessible terminal block where star-point formation and earthing shall be done.

All VTs shall have readily accessible HRC current limiting fuses on both primary and secondary sides. The class of insulation should be E or better.

The parameter & rating of CTs & PTs are minimum requirement & tentative only. Contactor shall submit the calculations for selection of CT/PT for approval to purchaser. Potential transformer secondary windings shall be rated 110 / $\sqrt{3}$ V Current transformer secondary windings shall have a rated current of 1A / 5A.

3.7.2.17 Nameplates and Labels

Each major and auxiliary item of equipment shall have a nameplate permanently affixed thereto, or as directed, showing in a legible and durable manner the serial number, name and address of the manufacture, rated capacity, speed, electrical characteristics, and other significant information, as applicable.



The module identification plate shall clearly give the feeder number and feeder designation wherever applicable. For single front switchboards, similar panel and board identification labels shall be provided at the rear also.

All name plates shall be of non rusting metal or 3-ply lamincoid with white engraved lettering on black back-ground, inscriptions and lettering sizes shall be as per their standard practice. Suitable plastic sticker labels shall be provided for easy identification of all equipment, located inside the panel/module. These labels shall be positioned so as to be clearly visible and shall give the device number, as mentioned in the module wiring drawings.

3.7.2.18 Motors

All electric motors for driving various equipment shall conform to relevant standards viz. IEC, BS or IS as applicable. The motor rating, torque characteristics, speed etc. shall be selected to suit the duty requirements.

Type of starter for motors shall be duly approved by the purchaser during detailed engineering. The detailed design calculation for selection of type of starters is to be submitted for approval. The priority for type of starters shall be in the following order:

1. Variable frequency drive
2. Soft starter
3. Star delta/ auto –transformer
4. Direct on-line starter

The enclosure of each motor shall be of the type best suited for the service conditions of the motor. The motor insulation shall be resistant to moisture, oil or oil vapor and the motors in general shall be so designed as to suit the tropical climate. Varnished cambric or glass insulation class F shall be used for connection from the windings to the terminals.

The terminal box shall be closed conduit box type conveniently located, and shall have means for terminating the external wiring for outdoor use. The motor terminals shall be of the stud type totally enclosed. Eye bolts or lugs shall be provided for lifting.

Space heaters to avoid condensation shall also be provided. Special type of motors, not adequately covered by these specifications, shall be offered for any special application, but these shall be subject to the approval of purchaser.

3.7.2.19 Space heaters

Space heater shall be provided in the Distribution Boards, Control & Protection panels, Motor Control panels etc. The space heaters shall be suitable for continuous operation on 240V AC, 50 HZ single phase supply, and shall be automatically controlled by thermostats. Necessary isolating switches and fuses shall also be provided.

3.7.2.20 Auxiliary relay, contacts and devices

All relays and timers in protective circuits shall be flush mounted on panel front with connections from the inside. They shall have transparent dust tight covers removable from the front. All protective relays shall have a draw out construction for easy replacement from the front. They shall either have built-in



test facilities, or shall be provided with necessary test blocks and test switches located immediately below each relay. The auxiliary relays and timers may be furnished in non-draw out cases.

All AC auxiliary relays shall be suitable for operation with VTs and CTs secondaries.

DC auxiliary relays shall be designed for 220V DC unless otherwise specified and shall operate satisfactorily between 80% and 110% of the rated voltage. Relays shall have adequate thermal capacity for continuous operation in circuits in which they are used.

All protective relays and timers shall have at least two potentially free output contacts. Relays shall have contacts as required for protection schemes. Contacts of relays and timers shall be silver faced and shall have a spring action. Adequate number of terminals shall be available on the relay cases for applicable relaying schemes.

Suitable number of auxiliary contacts or auxiliary relays shall be provided with each VCB's / ACB's for indication, remote indication, annunciation and automatic changeover and interlocking scheme.

All protective relays, auxiliary relays and timers shall be provided with hand reset operation indicators (flag) for analysing the cause of operation.

3.7.2.21 Welding & NDT

Preparation of base material

Members to be joined by welding may be cut to shape and size by mechanical means such as shearing, machining, grinding, or by gas or arc cutting, to suit the conditions. Edges shall be shaped according to ASME requirements. Design of welded joints and selection of weld filler metal shall be in accordance with approved standards and shall allow thorough penetration and good fusion of the weld with the base metal. The edges of surfaces to be welded shall be sound metal free of visible defects such as laminations or defects caused by cutting operation at least 30 mm back from the edge of the weld, and free from rust, oil, grease, and other foreign matter.

The establishment of welding procedures, welder's qualifications shall conform to the requirements of the ASME Boiler and Pressure Vessel Code Section VIII and IX. The approved copy of the WPS & WPQR in accordance with the ASME requirements shall be submitted to the purchaser for review and record.

3.7.2.22 Field welding

Filler material required for field-welded joints shall be furnished by the Contractor. The Contractor shall perform all welding work at site in accordance with the applicable WPS. Only qualified welders shall be used for undertaking welding as per the applicable WPS. NDT shall be performed as per the approved drawings.

Preparation for field welding

All cutting, chamfering, and other shaping of metals necessary for the field connection shall be done as far as possible in the shop. Adequate temporary bolted field connections shall be provided to hold the assemblies rigidly and in proper alignment during shop and field assembly.



To ensure proper alignment during field erection, a minimum of two dowels shall be provided for each field connection between subassemblies. The holes shall be drilled and the dowels fitted at shop assembly after the subassemblies have been satisfactorily aligned. All stipulations for welding, structural work and other, shall be applied to fieldwork as well as to shop work, except where otherwise stated.

3.7.2.23 Painting

All the equipment furnished and installed by the Contractor shall be completely painted for final use, with the exception of those parts or surfaces that are expressly designated as unpainted. Surfaces to be painted shall receive the preparatory treatment and required number of coats. The Contractor shall perform all painting work in the shop, before shipment, followed by a final coat of paint at site after installation as per the standard procedure.

All materials, supplies, and articles furnished shall be the standard products of recognized reputable manufacturers. Colour schedule of equipment supplied shall be finalized during detailed design stage.

3.7.2.24 Galvanization

All materials to be galvanized shall be of the full dimensions shown or specified and all punching, cutting, drilling, screw tapping and the removal of burrs shall be completed before the galvanizing process commences. All galvanizing shall be done by the hot dip process with smelter, not less than ninety eight percent (98%) of which must be pure zinc. No alternative process shall be used without the approval of the purchaser. No components shall be galvanized which are likely to come into subsequent contact with oil. Bolts shall be completely galvanized including the threads, but the threads shall be left uncoated in the case of nuts.

The zinc coating shall be uniform, clean, smooth and as free from spangle as possible. In the case of component parts, the zinc coating shall weigh not less than 0.6 kg/m² over the area covered and be not less than 0.09mm in thickness. All galvanizing shall comply with the requirements of the relevant ASTM standards/Indian Standards. All galvanized parts shall be protected from injury to the zinc coating due to differential aeration and abrasion during the period of transit, storage and erection. Damaged areas of the coating shall be touched up with an approved zinc dust paint or other approved flake metallic compound.

3.7.2.25 Pumps

All pumps forming part of the generating units and other plant and equipment shall be of high performance requisite type (viz. centrifugal, rotary etc.) and rating, of reputed make, and shall be directly coupled to their driving motors. The pumps shall be of self-priming type and with proper sealing systems and protection.

The materials of construction of pumps in general shall suit the service conditions. The materials of construction of the pumps handling water, such as drainage & dewatering pumps, turbine top cover drainage pumps etc. shall be resistant to abrasive effects of silt in such water. The pumps shall operate quietly without undue noise and vibration in their full operating range of head and flow. They shall be easy to maintain.

3.7.2.26 Embedded parts, Anchor Bolts and Fasteners

All embedded anchor bolts, rods, pipes, welding plates and support plates shall be provided by contractor. Anchor bolts shall consist of a threaded steel rod installed inside a pipe sleeve to provide



lateral adjustment after the sleeve is embedded. The threaded end of the rod shall be provided with two steel nuts and two steel washers to permit leveling and anchoring the equipment prior to grouting.

Approved types of expansion or chemical anchors shall be used where practicable for small equipment.

3.7.2.27 Rust Prevention and Protection during Transit:-

Bright steel parts including all machined surfaces shall be given a thick coat of tar or tallow or any other approved rust resisting paint in plain colour to prevent rusting during shipment and transport.

3.7.2.28 Civil Works

Civil foundations for equipment of the generating units and other plant and equipment will be prepared by the Purchaser in accordance with the basic design data to be supplied by the Contractor.

The Contractor shall provide design for foundations and install the concrete inserts/embedment; support steels and/or components for foundation /supports purpose, shall do any chipping / levelling works, denting / painting etc.

3.7.3 Erection, Testing, Commissioning and performance of Guarantee Tests

3.7.3.1 Testing and inspection

Materials used for construction of major & important sub-assemblies shall be thoroughly shop tested and inspected by the Contractor at his own expense prior to dispatch. Shop test shall comprise of routine test & type tests.

The shop tests and inspections shall be as spelt out in individual equipment specifications as dealt in succeeding sections but shall not be limited to the same. Any other tests and inspection not specifically listed but are otherwise considered essential and advisable shall also be conducted.

The Bidders shall furnish schedule of the shop tests and inspections on materials and equipment. Important tests/inspections shall be subject to witness by the purchaser for which the Contractor shall give sufficient advance notice. In case purchaser is unable to witness shop tests/inspections, the Contractor shall be so intimated and the tests/inspections may then be carried out in the absence of the Purchaser.

Equipment on which tests and inspections have been duly witnessed and approved by the Purchaser may be dispatched by the Contractor. Equipment on which tests and inspections have not been witnessed by the purchaser shall be dispatched only after the shop tests and inspection Certificates have been approved by the Purchaser.

3.7.3.2 Dimensional Checks and Visual Inspection

Dimensional checks shall be performed on all major parts, components and partial assemblies, especially when close tolerances and fits are involved (tolerance of shafts, between stationary and moving parts, connecting dimensions for the assembly with other supplies, etc.). If the dimensional checks show discrepancies in measurement, which may affect the fit, assembly or dismantling of the respective part or component, the same have to be corrected correspondingly. Such correction or modification shall, however, in no way lead to sacrifices with respect to reliability of operation or interchangeability, and shall be performed only after the agreement of the Owner has been obtained. If the



correction or modification cannot be carried out in accordance with the terms mentioned above, the part or component concerned may be subject to rejection. Faulty machine parts or equipment shall by no means be delivered.

3.7.3.3 Functional Tests

Functional tests on partial assemblies and/or complete assemblies shall be carried out as much as possible already in the manufacturer's workshops. Such tests shall be performed as far as possible under operation-like conditions.

When requested by the Owner, the functional tests shall be repeated until full proof has been obtained that the functioning of the assemblies will comply with the requirements of the Contract Documents.

3.7.3.4 Erection, commissioning & field tests

The Contractor has to do all the work related to assembly, erection, testing and commissioning complete in all respects. All necessary tools, plants, labour, materials including consumables for performing installation, testing and pre-commissioning shall be provided by the Contractor.

The Contractor shall submit the necessary data/information, layout and foundation/support drawings well in advance. The Contractor shall provide and install the concrete inserts/embedment, support steels and/or components for foundation/supports purpose as per approved erection drawings and coordinate the activities with civil contractors to keep his activities in synchronism with civil work. All installation for foundation shall be verified and accepted by the Engineer.

The Contractor shall use anchor fasteners for installation of piping, fixtures, mountings, conduits, cabling, panels etc. Minor Chipping of concrete is permitted. However, taking support from reinforcement bars shall not be allowed.

3.7.3.5 Installation procedure

The Contractor shall submit six copies of all detailed programs and the procedures to be adopted for erection / installation, testing and commissioning well in advance, before start of erection activities/ installation.

The installation procedure shall also have a section "site quality assurance plan" containing erection data sheets / site protocols for various components. These sheets should specify site measurements/ inspections required to be made for ensuring proper installation.

3.7.3.6 Cable laying

Wiring between equipment enclosures shall be made with cables, laid in trenches and/or cable trays and in cable conduits. The Contractor shall submit for review to the Engineer a cable route layout-showing location of trenches, conduits and trays. All material for cable laying such as cable trays supports and fastening material shall be furnished and placed by the Contractor. Cables shall be properly fastened and marked where they enter enclosures by either cable clamps or nipples.

Cables in horizontal cable trays shall be fastened properly with clamps or plastic strips. Power and control cables shall be placed in separate trays or conduits. Cables shall be clearly marked at each terminal point and appropriate intermediate locations as per Standard.



Conduits shall be of heavy gauge rigid steel, hot-dip galvanized, cut square reamed, threaded and screwed tight at all joints.

Conduit entrances to pull boxes and switches shall have double lock nuts & insulating bushings. No running thread shall be used.

Flexible metallic conduit shall be used for connection to equipment, which are subject to vibration, and also for connection to level/limit/pressure switches.

3.7.3.7 Field inspection

The Contractor shall permit Engineer to perform inspections of the assembly which will include a complete verification of the assembly of all parts as to their levels, clearances, pertinent fits, alignments and quality of workmanship. The field supervisor of the Contractor shall provide Engineer with three (3) copies of all the clearances, tolerances and data of all pertinent fits, alignments and levels, so that the latter may repeat the Contractor's measurement, if desired.

Unless otherwise specified, any rejection based on the inspection will be reported to Contractor within fifteen (15) days.

3.7.3.8 Field tests

All field tests including tests during installation, pre-commissioning, commissioning, performance and field acceptance tests shall be conducted by the Contractor, in the presence of representative of the Employer. Procedure to be adopted for conducting these tests shall be submitted well in advance, before start of relevant testing, for approval of the Employer.

The equipment / system shall be deemed to be commissioned and ready for trial run only after successful operation for a test service period specified in sub clause "Performance Testing". In the event of any failure this period shall be repeated for any number of times till the successful operation as described above is achieved.

All test equipment and instruments shall be furnished by the Contractor and will remain the Contractor's property after the fulfillment of all field tests.

Any defects or leaks disclosed in the tests shall be duly mended/ repaired to meet the desired function and retested. All necessary materials and labour for performing all the above tests shall be provided by the Contractor.

The Contractor shall prepare written test certificates in a form agreed upon by the Contractor and Employer of all tests results and hand them over to the Employer in due time.

The design, location and approval tests of anchoring rings for the fixing of lifting apparatus necessary for assembly and dismantling of equipment and plant accessories shall be the responsibility of the Contractor.

3.7.3.9 Taking over of facilities

"Taking over" means that the Facilities (or a specific part thereof where specified) have been completed operationally and structurally and put in a tight and clean condition, and that all work in respect of pre-commissioning of the Facilities or such specific part thereof has been completed and commissioning



has been attained as per Technical Specifications. The contractor shall make formal request for taking over the facility to the EIC.

3.7.3.10 Operation acceptance

The operational acceptance by the Employer of the Facilities (or any part of the Facilities where the Contract provides for acceptance of the Facilities in parts), which certifies the Contractor's fulfillment of the Contract in respect of Functional Guarantees of the Facilities (or the relevant part thereof) in accordance with the provisions of Specification.

3.7.3.11 Consumables, oils and Lubricant

The Contractor shall deliver to the Owner all equipment complete with initial fill of fluids, grease or lubricants, transformer oil, Nitrogen, SF6 gas and other used gases in non returnable drums / containers and replace any quantity used up or lost during installation and testing.

The oil used for the lubrication and oil pressure systems for the turbine, governor, shutoff valve and generator shall be preferably of the same type.

Supply

The Contractor shall furnish the following:

- (i) All oil for initial filling of all equipment supplied, plus additional oil equivalent to the first filling requirement of one unit.
- (ii) Grease if required for initial filling of all of the equipment, plus 10% additional.
- (iii) Gases for initial filling of all equipment supplied, plus 10 % additional quantity.
- (iv) Flushing fluids to flush and clean all systems.

3.7.3.12 Deleted:

3.7.3.13 Submission of Drawings, Documents, Manual, software, Calculations, Safety Margin Details etc.

All drawings and documents shall be submitted to purchaser in hard form as well as in editable soft form. Bidder shall submit Ten (10) number hard copies of the documents & drawings to purchaser for reference / review / approval. A comprehensive list of all such drawings/documents planned to be submitted for reference/approval shall be provided beforehand to the purchaser.

Loading drawings

For all larger pieces of Works which, due to their dimensions and/or weight and transport limitations, will require special means for their transportation, the Contractor shall submit binding loading drawings indicating dimensions, weights, etc., of the respective pieces of Works and the necessary trailer for its transportation to the site.

Foundation drawings

If a piece of works requires its own foundation or needs a special area for installation, the contractor shall submit drawings indicating all pertinent dimensions, static and dynamic loads, etc. They shall



include all essential details required for proper design and construction of the foundations and/or buildings.

In addition, they shall include openings, sleeves, slopes and the arrangement of any supporting structure, i.e. base-frames or other steel constructions for permanent fixing or erection purposes.

If conduits are to be installed in the foundations, the relevant information such as diameter, length, and purpose shall be indicated on the drawings.

Arrangement drawings

All arrangement drawings shall be drawn to scale. The General Arrangement Drawings shall show the physical arrangement of Works (constructions, machines, complete switchgears, control panels, instrument cubicles, etc.), civil constructions (buildings, rooms, foundations, ducts, etc.) and reserved areas (for pipes, cables, lines, etc.) in relation to each other and to agreed co-ordinates and boundaries. Such drawings shall be prepared for the whole plot, for separate plots and for each building (building, hall, room, ducts and trenches, etc.).

Outline drawings

The Outline Drawing shall show all elements and the main dimensions of individual components where necessary in plan view, cross-section, side and top views. If reasonably possible such dimensions can be shown on Arrangement Drawings.

Design drawings

The Design Drawings shall include the shop drawings, assembly drawings, erection drawings, piping diagrams and piping arrangement drawings, etc., showing the dimensions, design and data of all constructions, apparatus and Works to be furnished under this Contract. The drawings shall - where applicable - substantially conform to the Contract Drawings and shall show:

- 3-D Assembly drawings for major components in hard and soft form.
- Details of manufacturing and treatment of major single work pieces specially manufactured for this Contract
- Assembly of the Works in plan and elevation with main dimensions Sub-assembly of the principal components of the Works with overall dimensions, adjustment and clearance tolerances, numbers of corresponding detail drawings
- Sub-assemblies in which the Contractor proposes to ship the Works
- All necessary details of the parts connecting to the Works supplied by others
- Location and sizes of auxiliary connections for oil, grease, water, air, electrical power etc.
- Location and size of the instruments and accessories provided
- Methods of lubrication and sealing
- Instructions for heat treatment, pressure tests, surface preparation and anticorrosive protection
- Full details of parts for which adjustment is provided or which are subject to wear
- Method and sequence of installation, field joints, erection and lifting devices, jacks, grout plugs, anchoring details, etc., if not shown on foundation drawings.

Installation drawings

The construction, mechanical, electrical and I & C Installation Drawings shall provide detailed information on the disposition of the various items of a system (e.g. lighting fixtures, socket outlets,



connection boxes, transmitters, actuators, loudspeakers, telephones, pipes, valves, pumps, compressors, etc.) and of the piping and wiring respectively included in the installation or assembly. They shall be based on dimension drawings of cubicles, rooms, buildings or areas containing the Works.

Diagrams

Single-line diagrams

This is a simplified diagram of the essential electrical Works and their interconnections. Each circuit shall be represented by a single line only. It shall contain all required technical information of the Works represented, e.g. voltage, current, capacity, shortcircuit level, ratios, voltage variations, positive and zero sequence impedances, measuring transformer and protection relay indices, interlocking, kind of switch drive, code designation, etc. as applicable.

Circuit diagrams

The Circuit Diagrams shall show the power circuits in all the phases with the main apparatus as well as the pilot circuits (measuring and control circuits). It shall show in full the functioning of part or all installations, Works or circuits with all required technical details.

Block diagrams

The Block Diagrams shall be used to show in a simplified manner the main inter - relationships between the elements of a system by means of symbols, block symbols and pictures without necessarily showing all the connections. The symbols used for the individual kinds of components, e.g. servomotors, computing modules, etc., shall clearly be explained on the diagram or on an attached legend.

Logic diagrams

The Logic or Functional Diagrams shall be used for representation of logic and sequence controls and interlocking by showing only binary logic elements and their effect on the various process equipment disregarding their electrical realisation. Logic function elements (AND, OR, NOR, NAND, STORAGE, etc.) shall be used for processing and combining binary signals.

Terminal diagrams

Such diagrams shall be prepared for any type of terminal box, marshalling rack, control cubicle, switchboard, etc., and shall show the terminals (properly numbered) and the internal and/or external conductors (wires or cables) connected to them.

The terminal diagram of each individual switchboard, terminal box, panel, etc., shall contain, but not be limited to the following information:

Protection co-ordination diagrams

These diagrams shall show in a graphical manner separately for each power supply circuit:

- A simplified single-line diagram of the circuit with technical data of all instrument transformers and relays
- Co-ordinated tripping curves of related protection devices



- Setting of the protection devices.

Emergency shutdown diagram

This diagram shall show the sequential steps and interdependencies during emergency closure.

Flow Charts

Flow charts shall be used for representing sequence of events for start / stop / shut down of the machine including associated equipment and auxiliaries.

Manuals

The following manuals covering all equipment of EM works shall be supplied as per the time schedule in both editable soft and hard form:-

Sr.No.	Manual Description
1.	Storage and preservation manual
2.	Safety manual
3.	Erection Manual
4.	Testing and commissioning manual
5.	Operation manual
6.	Maintenance manual
7.	Long term storage manual for Generator Transformer
8.	Long term storage manual for boxed up component / equipment.
9.	Repair process / procedure manual for equipment / system

As built drawing to be provided incorporating changes made during erection, testing and commissioning.

Drawing & Document Submission Schedule

Drawings & documents submission schedule of the EM package with the categorization (i.e. Approval / reference) & tentative submission date shall be submitted to purchaser.

Preliminary list of drawings under various categories have been prepared and appended at Section 1 of the Technical Specification.

3.8 DRAWINGS & DOCUMENTS TO BE SUBMITTED BY THE SUCCESSFUL BIDDER AFTER AWARD OF CONTRACT

One set of soft copies of all the approved drawings, documents including as built drawings shall be furnished by the Bidder to the Owner / Consultant in compact discs.

White prints or other non-reproducible drawings can be mailed folded. Blue prints shall generally not be used.

All drawings, prepared by the Bidder shall be as per IS: 696. Supplier's standard drawings are exempted from the above size limitation, unless his "standard" includes drawings of very large size or length. There shall be sufficient reference notes on the drawings to permit identification of all the drawings which are required for a proper understanding.



Bills of material and drawings shall be cross-referenced for easy identification.

All drawings shall be dimensioned in the metric system. Where drawings are usually made in the British (or other) system, they shall also have metric system dimensions in parentheses or below dimension line. Titles and written notations shall be in English. If the original is in another language it shall carry English translation. The translations will appear immediately on the drawings. Attached lists of translated words shall not be accepted.

Drawings and bills of material shall be identified by a numbering system to be mutually agreed later on. Any additional identification numbers or symbols that the Bidder selects to use for his own purposes are permissible so long as Owner's number is the prime means of identification.

The scale of the drawing shall be shown clearly in the title block of the drawing. Wherever possible, scales of drawings shall be:-

1:1	1 : 2.5	1 : 5	1 : 10	1 : 20	1 : 25
1:50	1 : 100	1 : 200	1 : 300	1 : 500	
1: 1000	1 : 2000	1 : 5000			

All reproducible must be made from original drawings.

All revised drawing shall clearly indicate the number, date and subject to each revision. All the revisions carried out in the drawings shall be clearly identified and marked.

Drawing list shall be kept up-to-date, incorporating all new additions, cancellations and changes, and will be reissued periodically with Progress Report.

General arrangement drawings shall be submitted for approval to the Owner/ Consultant prior to the commencement of detail engineering by the Bidder. These drawings shall show to scale all major equipment including electrical equipment and building outlines and overall dimensions as well as tie-in dimensions and clearances shall be clearly indicated. Approved arrangement drawings shall be used as basis for design and preparation of detail drawing to be prepared by the Bidder. The Bidder shall furnish all the necessary drawings, data etc., of the plant/equipment with appropriate "Status" stamp in adequate no. of copies as indicated below:

S. No.	DESCRIPTION	TENDER STAGE	CONTRACT STAGE FOR APPROVAL	FINAL DOCUMENTATION	
			Prints	Prints	CDs
1	Drawings and Data Sheets	1	6	10	-
2	Drawings "As Built "	-	-	10	-
3	Type Test Reports	1	6	10	02
4	Erection Manuals	-	6	10	-
5	Operation and Maintenance Manuals	-	6	10	-
6	Manufacturing Quality Plan	1	6	10	-



CLIENT - SJVN ARUN-III POWER DEVELOPMENT COMPANY (P) LTD. (SAPDC)

TB-405-553-001

CONSULTANT- SJVN LTD.

Rev. 00

PROJECT: 4x225MW ARUN-III, HYDRO ELECTRIC PROJECT, NEPAL

Page | 21

TECHNICAL SPECIFICATION FOR AIR CONDITIONING & VENTILATION SYSTEM

7	Field Quality Plan	1	6	10	-
8	Inspection Test Reports	-	-	10	-

All instruction manuals / O&M Manual"as built drawing": 10 copies each

3.8.1.1 QUALITY ASSURANCE PROGRAMME

The Bidder shall follow Quality Assurance Programme to ensure that the equipment and services under the scope of contract whether manufactured or performed at the Bidder's works or at his sub-vendor's premises or at the SAPDC's site or at any other place of work are in accordance with the technical specifications. Such programme shall be outlined by the Bidder and be submitted along with the bid. The QA programme shall be generally in line with IS/ISO- 9001 and generally cover the following:

- ORGANISATION STRUCTURE FOR THE MANAGEMENT AND IMPLEMENTATION OF THE
- PROPOSED QUALITY ASSURANCE PROGRAMME
- QUALITY SYSTEM MANUAL
- DESIGN CONTROL SYSTEMS
- DOCUMENTATION AND DATA CONTROL SYSTEMS
- QUALIFICATION/EXPERIENCE OF BIDDER'S KEY PERSONNEL.
- PROCEDURE FOR PURCHASE OF MATERIAL, PARTS, COMPONENTS AND SELECTION OF SUB-VENDOR'S SERVICES INCLUDING VENDOR ANALYSIS, SOURCE INSPECTION, INCOMING RAW-MATERIAL INSPECTION, VERIFICATION OF MATERIALS PURCHASED, ETC.
- SYSTEM FOR SHOP MANUFACTURING AND SITE ERECTION CONTROLS INCLUDING PROCESS, FABRICATION AND ASSEMBLY.
- CONTROL OF NON-CONFORMING ITEMS AND SYSTEM FOR CORRECTIVE ACTIONS AND
- RESOLUTION OF DEVIATIONS.
- CONTROL OF CALIBRATION AND TESTING OF MEASURING / TESTING EQUIPMENT.
- SYSTEM FOR QUALITY AUDITS.
- SYSTEM FOR IDENTIFICATION AND APPRAISAL OF INSPECTION STATUS.
- SYSTEM FOR AUTHORISING RELEASE OF MANUFACTURED PRODUCT TO THE PURCHASER.
- SYSTEM FOR TRANSPORTATION /DELIVERY, HANDLING, STORAGE AND PRESERVATION.
- SYSTEM FOR MAINTENANCE OF RECORDS.

GENERAL REQUIREMENTS - QUALITY ASSURANCE

All materials, components and equipment covered under scope and its technical specifications shall be procured, manufactured, erected, commissioned and tested at all the stages, as per a comprehensive Quality Assurance Programme agreed mutually.

Minimum Quality Assurance Test Requirement (QATR) to be followed during Manufacturing and Field erection indicating requirement of various tests / inspections, on major equipment / items, to be carried out as stipulated in technical specification and standards mentioned therein, are attached hereto and are part of bidding documents.

Clarification, if any, on these quality assurance test requirement, raised by bidder shall be discussed and resolved during pre-bid meeting.

After the award of contract, the contractor shall submit the detailed Manufacturing & Field Quality Assurance Plans for complete equipment / material during detailed engineering in the format attached



CLIENT - SJVN ARUN-III POWER DEVELOPMENT COMPANY (P) LTD. (SAPDC)

TB-405-553-001

CONSULTANT- SJVN LTD.

Rev. 00

PROJECT: 4x225MW ARUN-III, HYDRO ELECTRIC PROJECT, NEPAL

Page | 22

TECHNICAL SPECIFICATION FOR AIR CONDITIONING & VENTILATION SYSTEM

hereto (format of quality plan F-060-02 issue 2.0 rev. 01, Total 1 Page) for approval and acceptance by SAPDC/Consultant in line with technical specification, Quality Assurance – General & Test Requirements and detailed engineering.

Manufacturing Quality Assurance Plans shall detail out for all the components and equipment & various tests/inspection, to be carried out in conformity with relevant latest IEC/IS/ISO etc, quality practices and procedures to be followed by Contractor's / Subvendor's Quality Control Organization, the relevant reference documents, standards and acceptance norms etc. during all stages of material procurement, manufacture, assembly and final testing / factory acceptance tests.

The Field Quality Assurance Plans shall detail out the various tests/inspection to be carried out in conformity with relevant latest IEC/IS/ISO, quality practices and procedures etc. to be followed by the contractor's / sub-contractor's site Quality Control Organisation during various stages of site activities from receipt of material/equipment at site till final commissioning/ acceptance/handover.

All major items/ equipment/ components to be manufactured in house as well as procured from sub-vendors (Bought out Items, BOI) to be listed in the bid. Bidder shall submit Quality Assurance Plan submission schedule in the bid for above listed items in attached Format (duly filled in the format F-060-05 Issue 2.0 Rev. 00, Total 1 Page) in line with L2 Schedule.

For components / equipment / Bought out Items procured by the contractor for the purpose of the contract, the Contractor's purchase specifications and inquiries shall call for quality plans to be submitted by the sub-vendors.

The quality plans called for from the sub-vendors shall detail out, during the various stages of manufacture and installation, the quality practices and procedures followed by the sub-vendor's quality control organisation, the relevant reference documents/standards used, acceptance level, inspection of documentation raised, etc.

Such quality plans of the successful sub-vendors shall be finalized with the SAPDC/Consultant in line with requirement mentioned above and such approved Quality Plans shall form a part of the purchase order/contract between the contractor and his sub-vendor.

Within three weeks of the release of the purchase orders /contracts for such bought out items /components, a copy of the same without price details but together with the detailed purchase specifications and other related documents such as data sheet, drawings, quality plans and delivery conditions shall be furnished to the SAPDC/Consultant by contractor along with a report of the Purchase Orders placed, on the monthly basis, so far for the contract.

The Quality Plans shall be submitted on electronic media e.g. CD or E-mail in addition to hard copy, for review and approval of SAPDC/Consultant. After approval, the same shall be submitted in compiled form on CD-ROM by contractor.

For all spares, replacement items and additional similar items, the quality requirements/Quality Plans as agreed for the main equipment supply shall be applicable.

All material of construction shall be as per technical specification / approved drawings / GTP.

Contractor's Plant internal standards must be traceable to acceptable International / National standards & salient points of difference (if any) shall be clearly stated with submission of plant standards. The contractor shall furnish copies of reference documents, plant standards, acceptance norms, test and



CLIENT - SJVN ARUN-III POWER DEVELOPMENT COMPANY (P) LTD. (SAPDC)

CONSULTANT- SJVN LTD.

PROJECT: 4x225MW ARUN-III, HYDRO ELECTRIC PROJECT, NEPAL

TECHNICAL SPECIFICATION FOR AIR CONDITIONING & VENTILATION SYSTEM

TB-405-553-001

Rev. 00

Page | 23

inspection procedure etc. as referred in Quality Plans along with Quality Plan to SAPDC/Consultant. These Quality Plans and reference documents/standards etc. will be subject to approval of SAPDC without which manufacturer shall not proceed. These documents shall form a part of the contract.

Tests on components and sub-assemblies shall be carried out at various stages of manufacturing, till the product undergoes the final tests in conformity with the relevant standards.

The Customer Hold Points (CHPs), identified in approved quality plan, i.e. testing checks which shall be carried out in the presence of the SAPDC, beyond which the work will not proceed without written consent of SAPDC's authorized representative.

The contractor / sub-vendor shall carry out routine test on 100% items at his works. The quantum of check / test for routine and acceptance test by SAPDC/Consultant shall be generally as per criteria / sampling plan defined in referred standards. Wherever standards have not been mentioned, quantum of check / test for routine / acceptance test shall be as agreed during detailed engineering.

The quantum of check when specified in percentage (%) / sampling basis shall be treated as per lot per sub-vendor. When the quantum of check is indicated to in whole no., then same quantum of check shall be applicable to each sub-vendor supplying the same equipment.

For sub-vendors identified during pre-award stage for submission of vendor details/ credentials (category "DR"), contractor shall submit documents in format F-060-01 after placement of award in the manner as specified as under prior to any procurement and within a month after placement of award or a period as agreed at the time of pre-award discussions.

The proposed sub-vendors should be registered vendors of the bidder and must have proven experience for successful operation for similar equipment / items / processes as mentioned elsewhere in technical specification.

Before assigning any portion of work to the sub-vendor, other than one specified and duly accepted in the contract, the contractor will take prior approval of BHEL/SAPDC.

Normally no request for change of sub-vendors or inclusion shall be entertained by SAPDC. But in exceptional circumstances, if the request for change of sub-vendors or inclusion is found reasonable and justified, then the same shall be entertained and the decision of SAPDC in this respect shall be final and binding. The time consumed for the change / inclusion of sub-vendors shall not be excluded from the stipulated time of the completion of the contract. This change shall not relieve the contractor from the responsibility to complete the work within stipulated time in any manner.

The contractor's proposal shall include sub-vendor's facilities established at the respective works, the process capability, process stabilization, Q.C. system followed, experience list etc. along with his own technical evaluation of sub-vendor. (Format F- 060-01 issue 2.0 rev. 01, Supplier / Sub-vendor Assessment Sheet, Total 14 pages).

However, whenever felt necessary, sub-vendor assessment will also be carried out by SAPDC/Consultant in accordance with the above procedure and by factory visits; for existing/proposed vendors/sub-vendors. This approval shall not relieve the contractor from any obligation, duty or responsibility under the contract & SAPDC shall not be responsible for any complications arising between the contractor and his subcontractor(s) / sub-vendor (s) and / or any other liabilities.



CLIENT - SJVN ARUN-III POWER DEVELOPMENT COMPANY (P) LTD. (SAPDC)

CONSULTANT- SJVN LTD.

PROJECT: 4x225MW ARUN-III, HYDRO ELECTRIC PROJECT, NEPAL

TECHNICAL SPECIFICATION FOR AIR CONDITIONING & VENTILATION SYSTEM

TB-405-553-001

Rev. 00

Page | 24

SAPDC/Consultant reserves the right to carry out quality audit and quality surveillance of the system and procedures of the contractor / or their sub-vendor. The contractor shall provide all necessary assistance to enable SAPDC/Consultant to carry out such details & surveillance including Quality Manuals, if required by SAPDC/Consultant.

All welding and brazing shall be carried out as per procedure drawn and qualified in accordance with requirement of ASME section-VIII/IX or other International equivalent standard acceptable to SAPDC/Consultant. All welding/brazing procedures shall be submitted to SAPDC/Consultant/BHEL for review / verification prior to carrying out the welding/brazing. However, wherever required by the SAPDC/Consultant, tests shall be conducted in presence of SAPDC's authorized representative.

All Brazers, Welders and welding operators employed on any part of the contract either in Contractor/his sub-vendor's works or at site or elsewhere shall be qualified as per ASME section-VIII/IX or other equivalent International Standards acceptable to SAPDC/Consultant.

Unless otherwise proven and specifically agreed with SAPDC/Consultant, welding of dissimilar material and high alloy materials shall be carried out at shop only.

All non-destructive examination shall be performed in accordance with written procedures as per International Standards. The NDT operator shall be qualified as per SNT-TC-IA (of the American or Indian Society of non-destructive examination). NDT shall be recorded in a report, which include detail of methods and equipment used, result/evaluation, job data and identification of personnel employed and details of correlation of the test report with the job.

All material used for equipment manufacture including castings and forgings, etc. shall be of tested quality as per relevant codes/standards. Details of results of the tests conducted to determine the mechanical properties; chemical analysis and details of heat treatment procedure recommended and actually followed shall be recorded on certificates and time temperature chart. Tests shall be carried out as per applicable material standards and/or agreed details.

Contractor shall submit Field Welding Schedule for field welding activities like field welding location, numbers, welding procedure to be used, requirements, codes and NDT requirement along with all supporting documents, like welding procedures, heat treatment procedures, NDT procedures, etc. to SAPDC/Consultant for review at least ninety days before schedule start of erection work at site.

Any other statutory requirements as applicable for the equipment / systems shall also be complied with.

The inspection calls (duly filled in the format F-060-06 Issue 2.0 Rev. 00, total 1 Page) shall be placed at least 06 weeks in advance for overseas inspections excluding India and 15 days in advance for inspections within India and Nepal.

Before submitting the inspection call to SAPDC for witnessing the Customer Hold Points (CHP's) and/or requesting SAPDC for issuance of Material Dispatch Clearance Certificate (MDCC) based on Test Certificate (TC) review / Certificate of Conformance (COC), the contractor shall ensure that all Drawings / documents / GTP / technical data sheet, relevant to respective CHP / MDCC requirement, has been duly approved /accepted / noted by SAPDC.

Contractor shall ensure readiness of offered equipment by all means, before raising such call to SAPDC to attend CHP inspections. In case, SAPDC engineer (s) on reaching at a place of inspection found that material is not ready for inspection due to whatsoever reason, the complete inspection expenditure of SAPDC engineer(s) as per actual shall be chargeable to the contractor.



CLIENT - SJVN ARUN-III POWER DEVELOPMENT COMPANY (P) LTD. (SAPDC)

CONSULTANT- SJVN LTD.

PROJECT: 4x225MW ARUN-III, HYDRO ELECTRIC PROJECT, NEPAL

TECHNICAL SPECIFICATION FOR AIR CONDITIONING & VENTILATION SYSTEM

TB-405-553-001

Rev. 00

Page | 25

Only calibrated testing & measuring instruments shall be used while performing tests during manufacturing and erection, testing & commissioning at site by the contractor. Copy of the calibration certificates will be submitted to SAPDC/Consultant by the contractor during inspection as an evidence.

Non-conformities observed during manufacturing, shop testing, handling, packaging, transportation, storage, preservation, erection, testing & commissioning are required to be intimated by the contractor (Format for reporting, F-060-04 issue 2.0 rev 01, Total 5 pages). The acceptance/rejection of the non-conformities will be at the discretion of SAPDC.

Repair/rectification procedures to be adopted to make the job acceptable shall be subject to the acceptance of SAPDC. Action taken in accordance with decision of disposal of non-conformity for repair / rework / modification of the item / equipment and to prevent re-occurrence. The corrective and preventive action may involve modification of item / equipment, change in procedure and system etc. to achieve quality improvement at all stages and levels.

Quality audit/surveillance/approval of the results of the tests and inspection will not, however, prejudice the right of the SAPDC to reject the equipment if it does not comply with the specification when erected or does not give complete satisfaction in service and the above shall in no way limit the liabilities and responsibilities of the Contractor in ensuring complete conformance of the materials/equipment supplied to relevant specification, standard, data sheets, drawings etc.

No material shall be dispatched from the manufacturer's works before the same is duly accepted, subsequent to pre dispatch/final inspection including verification of records of all previous tests/inspection by SAPDC and duly authorised for Dispatch by issuance of Material Dispatch Clearance Certificate (MDCC).

The test reports of type tests conducted as per contract, in line with requirement stipulated in the technical specification / quality plan should be got accepted from SAPDC/Consultant before final inspection / issuance of MDCC.

All materials used or supplied shall be accompanied by valid and approved material certificates and tests and inspection reports. These certificates and reports shall indicate the heat numbers or other such acceptable identification numbers of the material. The material certified shall also have the identification details stamped on it to ensure physical correlation and traceability of material vis-a-vis test certificate. Such identification no. shall remain same and verifiable for all stages of manufacturing and installation.

3.8.1.2 QA DOCUMENTATION

The contractor shall be required to submit the QA Documentation in two hard copies and two CD ROMs, as identified in respective quality plan.

Each QA Documentation shall have a project specific Cover Sheet bearing name and identification number of equipment including index of its contents with page control on each document. The QA Documentation file shall be progressively completed by the Contractor/sub-vendor to allow regular reviews by all parties during the manufacturing.

The final quality document will be compiled and issued at the final assembly place of equipment before despatch. However, CD-ROM may be issued not later than three weeks.



CLIENT - SJVN ARUN-III POWER DEVELOPMENT COMPANY (P) LTD. (SAPDC)

TB-405-553-001

CONSULTANT- SJVN LTD.

Rev. 00

PROJECT: 4x225MW ARUN-III, HYDRO ELECTRIC PROJECT, NEPAL

Page | 26

TECHNICAL SPECIFICATION FOR AIR CONDITIONING & VENTILATION SYSTEM

Before dispatch / commissioning of any equipment, the Contractor shall make sure that the corresponding quality document or in the case of protracted phased deliveries, the applicable section of the quality document file is completed. The Contractor will then notify the Inspector regarding the readiness of the quality document (or applicable section) for review.

The contractor shall be required to submit copies of the following quality assurance documents in original duly reviewed and accepted by contractor along with the request letter for issuance of MDCC (Material Dispatch Clearance Certificate):

- QUALITY PLAN CHECK LIST.
- MATERIAL MILL TEST REPORTS ON COMPONENTS AS SPECIFIED IN QUALITY PLAN.
- SKETCHES AND DRAWINGS USED FOR INDICATING THE METHOD OF TRACEABILITY OF THE
- RADIOGRAPHS TO THE LOCATION ON THE EQUIPMENT.
- NON-DESTRUCTIVE EXAMINATION RESULTS REPORTS INCLUDING INTERPRETATION REPORTS.
- CALIBRATION CERTIFICATE OF ALL METERS & MEASURING INSTRUMENTS PROPOSED TO
- BE SUPPLIED AS PART OF RELEVANT BILLING BREAKUP ITEM.
- ROUTINE TEST REPORTS FOR TESTING REQUIRED AS PER APPLICABLE CODES AND
- STANDARDS REFERRED IN THE SPECIFICATIONS.
- INSPECTION REPORTS DULY SIGNED BY AUTHORIZED REPRESENTATIVE OF SAPDC AND
- CONTRACTOR FOR THE AGREED CUSTOMER HOLD POINTS.
- ALL THE ACCEPTED DEVIATIONS SHALL BE INCLUDED WITH COMPLETE TECHNICAL DETAILS.
- LIST OF BALANCE POINTS IF ANY.
- CERTIFICATES IN RESPECT OF CALIBRATION, WELDERS & BRAZERS QUALIFICATION ETC.
- COPY OF ALL REFERENCE DRAWINGS AND REFERENCE TECHNICAL DOCUMENTS
- ACCEPTANCE OF TYPE TEST REPORTS BY SAPDC/CONSULTANT.

Similarly, the Contractor shall be required to submit two sets (two hard copies and two CD ROMs), containing QA Documentation pertaining to field activities as per Approved Field Quality Plans and other agreed manuals/procedures, within 2 weeks after commissioning of individual system.

On release of QA Documentation by Inspector, one set of quality document shall be forwarded to Consultant and other set to SAPDC. For the particular case of phased deliveries, the complete quality document to the SAPDC/Consultant shall be issued not later than 3 weeks after the date of the last delivery of equipment.

ASSOCIATED DOCUMENTS / FORMATS

- F-060-01 VENDOR / SUB-VENDOR ASSESSMENT SHEET
- F-060-02 QUALITY PLAN SUBMISSION BY CONTRACTOR
- F-060-04 NON-CONFORMANCE REPORT (NCR)
- F-060-06 INSPECTION CALL REQUEST



3.8.1.3 Safety

Safety of personnel

All equipment and services provided under this contract shall abide by international standards commonly accepted in the hydroelectric utility industry for safety of personnel whether involved with operation or maintenance.

Safety of operation

All equipment and services provided under this contract shall abide by commonly accepted standards for safety of operation.

The various system and sub-systems supplied under this contract shall be designed to follow and operate under a clear hierarchical structure:

- Plant control level,
- Unit control level,
- Functional control level, functional drive group level,
- Local drive level.

Each hierarchical control level shall perform its specific tasks and always depend on the subordinate lower control levels. In general, should a higher control level failure occur, the lower control level shall not be affected and shall be able to control the power plant with full safety.

The Contractor shall accordingly build into the "Electrical & Mechanical System" adequate levels of autonomy, independence, redundancy and functional distribution to insure that safety is maintained at all times.

3.8.1.4 Earthing

Earthing terminals for equipment of these specifications shall form part of equipment supplies. The contractor shall connect the earthing conductors to these terminals as required.

Risers from earthing bus shall be in the scope of purchaser. However, extension from these risers to the equipment shall be in the scope of supplier in the Power House, Transformer Hall, Switchyard and Butterfly Valve House.

However, overall earthing arrangement required for HT panel, LT panel, DG set, motor & motor control panels etc. at isolated location such as Dam Site, TRT Outfall area and Surge Shaft either by pit earthing or counter poise etc. shall be in the scope of supplier including civil works, design, material supply (for main earthing risers, interconnection, charcoal, salt, Bentonite etc.), erection, testing & commissioning etc.

A copper ground bus, sized to carry maximum short circuit current, shall run along the entire length of panel structure and shall have terminal connector at each end for connection to station ground grid (50 X 6 mm G.I. flat).



Tests

Each panel shall be completely assembled, wired, adjusted and tested at the factory prior to shipment. The test shall include wiring continuity tests, insulation tests and functional tests to ensure satisfactory operation and control of individual equipment.

Special Cables

Special cables for specific purpose, as required, shall be supplied and installed by the Bidder.

3.8.1.5 Completeness of the specification

Any fittings, accessories, equipment or any other things required for successful commissioning of Arun-III Hydro Electric Project, though may not have been specifically mentioned in the specification but are usually necessary for the completeness of the equipment shall be deemed to be included in the specification and shall be supplied by the contractor without any extra cost to the Employer.

3.8.1.6 Packaging and Shipment

The Contractor shall provide such packing of the Goods as it is required to prevent their damage or deterioration during transit to their final destination as indicated in the Contract. The packing shall be sufficient to withstand, without limitation, rough handling during transit and exposure to extreme temperatures, salt and precipitation during transit and open storage. Packing case size and weights shall take into consideration, where appropriate, the remoteness of the final destination of Goods and the absence of heavy handling facilities at all points in transit.

The packing, marking and documentation within and outside the packages shall comply strictly with such special requirements as shall be expressly provided for in the Contract and, subject to any subsequent instruction ordered by the Employer consistent with the requirements of the Contract.

After unpacking of Goods the packing material shall become the property of Employer

The contractor shall wrap, pack and crate all plant included in the work or part thereof, suitable for shipment to a tropical location, facilitating proper handling and protection from damage in rail, truck, ocean or air shipment as applicable. An approved drying agent, such as Silica Gel, shall be packed in containers or packages holding plant which may be adversely affected by moisture or excessive humidity.

All packing crates shall be clearly marked before shipping to indicate the contract number, shipping address, volume, weight, name, number and unit number of the contents, slinging and weight bearing points.

All plant parts shall be marked to facilitate erection. Each packing crate shall contain a packing list in a waterproof envelope. Parts shall be described and also identified by their numbered marking in the packing list.

Three copies of the packing list shall be forwarded to the purchaser prior to dispatch. The ownership of packaging materials shall be of Employer. All wooden packaging crates and steel support structures shall be dumped to the designated area within 5kms of the power house as per the direction of Engineer in charge.



The supplier shall be entirely responsible for the insurance, shipment, handling and transportation.

The equipment shall not be dispatched by the Bidder from the place of manufacture to the site until the dispatch instructions are issued by the Owner.

3.8.1.7 PACKAGING, HANDLING AND SITE STORAGE

The Contractor shall pack all the consignment in sea worthy packaging strong enough to withstand rough handling during transit. Machine surface shall be suitably protected against scratches, corrosion, shocks, impact etc. Packages shall be suitably and distinctly identified for type of handling and kind of storage.

Electronic equipment shall be packaged, shipped and stored in anti-static packing. All packages shall be stored indoor. Packages containing electronic equipment shall be stored in humidity controlled environment.

The Bidder shall indicate the number of packages of consignment together with the size (L x W x H) and weight for transporting the equipment in the Bidding Document.

3.9 SPECIAL INSTRUCTIONS TO BIDDERS

General

The Bidder shall base the equipment design on the information given in this specification. The equipment shall be complete in all respects. Any item which is not specifically mentioned herein but found essential for safe and efficient operation and maintenance and satisfactory performance of the system shall be deemed to have been included in the scope of the Bidder. It shall be presumed that the Bidder has studied the site, all the drawings, tender documents and is fully aware of the scope of work involved and the site conditions prevailing.

3.10 Codes and Standards

- a) All equipment, systems and works covered under this specification shall comply, in all respect, with requirements of applicable latest statutes and that of latest editions of codes and standards. Latest regulations and safety & environmental requirements as applicable in India / state of installation shall also be complied with.
- b) All codes and standards mentioned shall mean as relevant and applicable to a particular equipment / system.
- c) All other codes/standards not covered in Section 1 / Section 2 but required for the plant and system offered shall also be referred / followed by the Bidder. The Bidder, along with the bid, shall submit a comprehensive list of codes and standards to be followed for various equipment / system.
- d) In all cases where IBR does not govern, German, American, British, ISO or other international standards established to be equivalent or superior to the codes specified are also acceptable. In the event of any conflict between the requirements of equivalent codes and standards and the requirements of Indian standards / regulations, the latter will govern unless specified otherwise in the specifications.



- e) The Bidder shall be responsible to be in possession of all the specified Codes / Standards and ensure reference to the same before submitting the offer/ bid.
- f) Mandatory codes / local regulations to be followed for safety, design, fabrication and operation of the switchyard shall be, followed:
- g) If the equipment supplied does not conform to the codes and standards mentioned in this specification, but is manufactured to the Bidder's own standard, developed as a result of his experience, is also acceptable provided the same is found to be superior to the above mentioned codes and standards. The Bidder shall identify such equipment and shall also present sufficient data to the Owner / Consultant to support his design and to establish the superiority. The design may be accepted by Owner/ his Consultants only if the Purchase / his consultant is satisfied that sufficient experience exists with the design proposed.
- h) Design not meeting the stipulations of the codes and standards will not be acceptable.
- i) Apart from various codes and standards mentioned in Section 1/2, the Manufacturer shall comply with other requirements of codes and standards mentioned in this Specification for detailed design, manufacture, testing, erection, construction etc.

Control System	IEEE – 122 , 1992
Metering / Dosing pumps	API 675 – 1987 (Positive displacement pumps – controlled volume) API 676 – 1987 (Positive displacement pumps – Rotary).
Centrifugal pumps	API 610 – 1990, ASME PTC 8.2 – 1965
Gear Box	API 613 – 1993 & AGMA 420 & 421
Coupling	API 671 – 1993
Structural	IS 1893 – 1991, IS 875-1992 & IS 800 – 1991
Pressure Vessel	ASME Sec. VIII, Div. 1 – 1995
Piping	ANSI B 31.1-1995 / 31.3 – 1993, IBR
Valve	API
Instrument	ISA, API
Electrical	As per specification attached & relevant
	IS/IEC
Tanks	API 650- 1993
Electrodes	AWS, IS
Painting	IS Standards
Performances Tests	
Overload test of crane and hoists	IS 3177

3.11 Deviations and Assumptions

Bidders requested to carefully examine and understand the specifications and seek clarifications, if required, to ensure that they have understood the specifications. The Bidder's offer should not carry



any sections like clarifications, interpretations and/or assumptions. In the event of conflict between the Technical Specifications and the condition of contract, the requirements as indicated in the technical specification shall govern, unless confirmed otherwise by the Owner in writing before the award of contract, based on written request from the bidder for such a clarification.

In the event of conflict between requirements of any two clauses of the specification documents, the more stringent requirements shall apply, unless otherwise confirmed by the Owner in writing before the award of this contract, based on a written request from the Bidder for such clarification.

The Bidders are advised that while making their Bid Proposals and quoting prices, all terms and conditions of bidding documents may appropriately be taken into consideration. Bidders are required to furnish a certificate indicating their full compliance to the terms and conditions of the bidding documents.

3.12 Limit of Contract

Equipment furnished shall be complete in all respect with all mountings, fittings, fixtures and standard accessories normally provided with such equipment and/ or needed for erection, completion and safe operation of the equipment as required by applicable codes though they may not have been specifically detailed in the respective specifications, unless included in the list of exclusions. All similar standard components/ parts of similar standard equipment provided shall be interchangeable with one another.

This review by the Owner's Engineer / Consultant may not indicate a thorough review of all dimensions, quantities and details of the equipment, materials, any devices or items indicative of the accuracy of the information submitted. This review and/ or approval by the Engineer shall not be construed by the Bidder, as limiting any of his responsibilities and liabilities for mistakes and deviations from the requirements specified under these specifications and documents.

3.13 Latent Defects

Notwithstanding the issue of the Take Over Certificate, the Contractor shall be responsible for making good with all possible speed any Latent Defect in any Works /equipment of the plant which appears at any time before the expiry of defect liability period. And shall remedy such defect at its own cost and expense. The latent defect liability period shall be a minimum of 5 years from the end of defect liability period. The defects to which this applies are defects in design, materials or workmanship or defects arising from any act or omission of the Contractor done or omitted prior to Take-over of the portion of the Plant affected by the defects or during the Warranty Period which a reasonable examination at the end of the Warranty Period would not have disclosed.

3.14 Defect Liability

The Contractor warrants that all the facilities or any part thereof are new, unused, and of the most recent or current models, and that they incorporate all recent improvements in design and materials, unless provided otherwise in the Contract.

The Contractor further warrants that the Plant and equipment shall be free from defects arising from any act or omission of the Contractor or arising from design, materials, and workmanship, under normal use in the conditions prevailing in the

If during the Defect Liability Period any defect should be found in the design, engineering, materials and workmanship of the Plant and equipment supplied or part thereof, the Contractor shall promptly, in



consultation and agreement with the Employer regarding appropriate remedying of the defects, and at its cost, repair, replace or otherwise make good (as the Contractor shall, at its discretion, determine) such defect as well as any damage to the Facilities caused by such defect. The Contractor shall not be responsible for the repair, replacement or making good of any defect or of any damage to the Facilities arising out of or resulting from any of the following causes:

- (a) Improper operation or maintenance of the Plant and equipment by the Employer
- (b) Operation of the Facilities outside specifications provided in the Contract
- (c) Normal wear and tear.

3.15 Completion Schedule

The Bidder shall submit Time Bar chart indicating completion date of major activities such as submission of design data / calculations and drawings for approval, manufacturing of components / units, supply, inspection etc. without which the Tender shall not be considered. Time Bar Chart furnished shall afterwards form part of the contract and cannot be altered arbitrarily except Force Majeure conditions as may be agreed with the Owner.

3.16 Drawings & Documents for Owner's use and Archives

The Bidder shall submit all final drawings, documents, manuals for Owner's use and for reference / record required during course of operation and maintenance of the plant. Numbers of copies and their form (hard copy, electronic form, reproducible) to be submitted and the details of the documents, drawings, manual etc. to be furnished by the Bidder are described elsewhere in the specification.

Drawings, documents, calculation, data & Information to be submitted by the Bidder along with the offer:

Technical Data to be submitted with the Tender

- 1) List of performance tests proposed by the Bidder to demonstrate the guaranteed parameters for generator and other electrical equipment.
- 2) Specific energy consumption.
- 3) Type test certificates for major categories of equipment, issued by independent testing authority.
- 4) Guaranteed Technical Parameters.
- 5) Technical catalogues.
- 6) Manufacturing Quality Plan

Operation & Maintenance Manuals

Instruction manuals, presenting the basic categories of information for the operating and/or maintenance personnel, as detailed herein below shall be furnished by Bidder.

The instruction manuals shall present the following basic categories of information in particular complete and comprehensive manner and prepared for the use by operating and/or maintenance personnel.

- i. Instructions for initial commissioning, short duration and long duration shut down.
- ii. Instruction for operation, routine inspection and maintenance including preventive maintenance.



CLIENT - SJVN ARUN-III POWER DEVELOPMENT COMPANY (P) LTD. (SAPDC)

TB-405-553-001

CONSULTANT- SJVN LTD.

Rev. 00

PROJECT: 4x225MW ARUN-III, HYDRO ELECTRIC PROJECT, NEPAL

Page | 33

TECHNICAL SPECIFICATION FOR AIR CONDITIONING & VENTILATION SYSTEM

- iii. Recommendation for inspection points, method of inspection and period of inspection.
- iv. Information on detection, cause and rectification of troubles and faults.
- v. Instructions on normal repairs and overhaul.
- vi. Complete parts list with proper and complete identification (Tag nos./Serial nos. as shown in the respective approved drawings) and ordering information for all replaceable parts. The identification details of equivalent and alternative makes for these spare parts which are not manufacturer's own product shall also be listed.
- vii. List of all special tools and tackle & spares and instructions for use of such tools and tackle & spares.
- viii. One complete set of as built drawings of the entire systems.
- ix. The information shall be organized in a logical and orderly sequence. A general description of equipment including significant technical characteristics shall be included to familiarize operating and maintenance personnel with the equipment. Such description and technical characteristics shall not differ from the approved data.
- x. Necessary drawings, curves and other illustrations shall be included or copies of appropriate approved drawings shall be bound in the manuals. Tests, adjustment and calibration information, as appropriate, shall be included. Safety and other warning notices and installation, maintenance and operating cautions shall be emphasized.
- xi. Write-up, figures, part list etc., shall be clearly legible. The manuals shall be prepared on good quality paper securely bound in durable folders.
- xii. The instruction manuals shall be subject to Consultant's approval in the same fashion as that for drawings.
- xiii. Instruction manual shall give step by step procedure for Erection, testing and commissioning
- xiv. Operation, Maintenance and Repair Instruction manual shall also contain:
- xv. List of spare parts with ordering specifications and manufacturer's catalogues
- xvi. List of consumables, lubricants, chemicals with specifications, brand names and annual consumption figures.
- xvii. Drawings relevant for erection, operation, maintenance and repair of the equipment.
- xviii. Procedure for ordering spares.
- xix. Maintenance Manual shall also include:
- xx. Diagnostic trouble shooting / fault location charts
- xxi. Tests for checking of proper functioning.

Drawings / documents for approval

Quality Control & Quality Assurance plan.

G.A. and Cross Sectional drawings of all equipment indicating weights, material of construction, bill of material, dimension, specification etc.

Final design calculations and assumptions.

Actual performance data and characteristic curves based on the testing at site.

Technical specification of all equipment, motors, for all system and all other accessories.

Final list of drawings.

As built drawings.

Miscellaneous

- i. General arrangement and cross sectional drawings of all major components with bill of material.
- ii. Foundation drawings, load data & design calculation for all equipment.



- iii. Erection drawings for all equipment and structures showing complete erection details.
- iv. Engineering and design calculations of installations and units.
- v. QAPs
- vi. Detailed procedures of shop testing of all the items applicable shall be submitted to the Owner/ Consultant for approval before conducting tests.
- vii. Following shop test certificates/test curves/data, shall be furnished.
 - Materials and components test certificates.
 - Performance test results and characteristic curves of all fans, pumps, and electric drive motors etc.
 - Non-destructive test results as applicable.
 - Reports and test certificates of shop tests.
 - Type test & routine test certificates.
- viii. Detailed quality assurance program along with quality plan shall be submitted.

Following data shall be furnished:-

- a) Technical data of all the plant, equipment, drive motors, instruments, panels, etc. shall be furnished.
- b) Following lists/tables / write ups shall be furnished, complete with tag nos. and brief specification. Proper numbering system as approved by Consultant/Owner shall be adopted.
 - i) Instrument schedule (with service, range, make of instrument).
 - ii) Flow element schedule.
 - iii) Valve schedule.
 - iv) Pipe schedule.
 - v) Cable schedule (Power & Control).
 - vi) Schedule of actuators (electric/pneumatic)

The scheduled dates for the submission of these as well as for, any data/information to be furnished by the Employer would be discussed and finalized at the time of award. The supplier shall also submit required no. of copies as mentioned in this specification of all drawings/design documents/test reports for approval by the Employer.

Note: The contractor may please note that all resubmissions must incorporate, all comments given in the submission by the Employer failing which the submission of documents is likely to be returned. Every revision shall be a revision number, date and subject, in a revision block provided in the drawing, clearly marking the changes incorporated.

3.17 Workmanship and Quality Control

All moving parts of equipment, which can conceivably cause injury to the operator and otherwise authorized personnel within the vicinity of working area shall be suitably guarded and warning displays shall be put at prominent places.



CLIENT - SJVN ARUN-III POWER DEVELOPMENT COMPANY (P) LTD. (SAPDC)
 CONSULTANT- SJVN LTD.
 PROJECT: 4x225MW ARUN-III, HYDRO ELECTRIC PROJECT, NEPAL
 TECHNICAL SPECIFICATION FOR AIR CONDITIONING & VENTILATION SYSTEM

TB-405-553-001

Rev. 00

Page | 35

The Bidder shall clearly indicate and identify the plans and procedures, which shall be followed in the design, manufacture and installation of plant and equipment to control and assure to the Owner of the desired quality.

FUNGI STATIC VARNISH

Besides the space heaters, special moisture and fungus resistance varnish shall be applied on parts which may be subjected or predisposed to the formation of fungi due to the presence or deposit of nutrient substances. The varnish shall not be applied to any surface of part where the treatment will interfere with the operation or performance of the equipment. Such surfaces or parts shall be protected against the application of the varnish.

3.17.1 Equipment Mounting



All instruments, switches etc. mounted on the front face of the panels shall be of flush type.

All equipment shall be so mounted that removal and replacement may be accomplished individually without interruption of service to others.

All equipment inside the panel shall be so located that their terminals and adjustments are readily accessible for inspection and maintenance. Adequate ventilation shall be provided in enclosed panel.

Each of the LV switchboards shall be designed for 1.1 times the required rating as a spare capacity. Further all LV Switchboard shall be provided with 20 % spare modules of each rating and type of module.

3.18 Title Block :

Project	4x225MW Arun-3 (HEP),Nepal			
Customer	SJVN Arun-3 Power Development Company (P) Ltd. (SAPDC)			
Consultant	 एसजेवीएन SJVN	SJVN Ltd		
	BHARAT HEAVY ELECTRICALS LTD. TRANSMISSION BUSINESS GROUP NOIDA		Name	Sign
		Drawn		
		Checked		
		Approved		
Title	Drawing Number :		Rev	

-----XXXX-----



Relative Humidity Parameter for HVAC Design of Arun-3 HEP

1. Bioclimatic Zone of Arun-3 HEP Temperate Climate (Fig 2 below)*
(For Project Elevations, pl refer GTS & Tender Drgs)
2. Temperature Pl refer GTS 1.1.3
3. Design Parameter for Relative Humidity 20-90% (Table 1)*

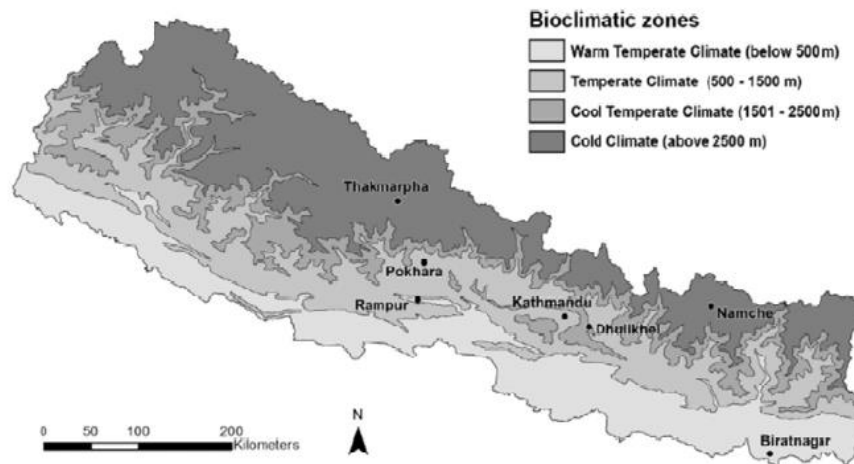

Fig. 2. Bioclimatic zoning map of Nepal with selected locations for energy simulation.

Table 1

Climate conditions in bioclimatic zones of Nepal (Bodach, 2014).

Bioclimatic zone	Temperature in Summer	Temperature in Winter	Relative Humidity
Warm temperate	22–35 °C	9–26 °C	25–90%
Temperate	18–35 °C	5–25 °C	20–90%
Cool Temperate	14–26 °C	–2–20 °C	30–90%
Cold	7–22 °C	–10– –2 °C	10–90%

* **Source:** Design guidelines for energy efficient hotel in Nepal (international journal of sustainable built environment / www.sciencedirect.com)



CLIENT – SJVN ARUN-III POWER DEVELOPMENT COMPANY (P) LTD. (SAPDC)

CONSULTANT- SJVN LTD.

PROJECT: 4x225MW ARUN-III, HYDRO ELECTRIC PROJECT, NEPAL

TECHNICAL SPECIFICATION FOR AIR CONDITIONING & VENTILATION SYSTEM

TB-405-553-001

Rev. 00

Page | 1

SECTION-4 LIST OF DRAWINGS & DOCUMENTS

Bidder shall submit the drawings & data sheets as per the following list:

DRAWING NO.	DRAWING NAME
TB-405-553-DG-01	AC Equipment Layout for GIS Control building
TB-405-553-DG-02	Ventilation equipment & Ducting layout for GIS building
TB-405-553-DG-03	GA Drawing of Ventilation Equipment for GIS Building
TB-405-553-DG-04	Ventilation fan layout for GIS Control building areas
TB-405-553-DG-05	Schematic, GA & SLD of PDB/MCC panel for GIS Ventilation
DATA SHEETS	DATA SHEETS NAME
TB-405-553-DS-01	TDS for Split AC
TB-405-553-DS-02	TDS for Cassette AC
TB-405-553-DS-03	TDS for Centrifugal fans
TB-405-553-DS-04	TDS For Supply Air Fans
TB-405-553-DS-05	TDS For Exhaust Fans
TB-405-553-DS-06	TDS For GI Sheet for Ducts
TB-405-553-DS-07	TDS For Supply Air Grills
TB-405-553-DS-08	TDS For Fire Damper
TB-405-553-DS-09	TDS For Volume Control Damper
TB-405-553-DS-01	TDS For Louvers
TB-405-553-DS-11	TDS For Non-Return Damper
TB-405-553-DS-12	TDS For Pre-filter & Fine filter
TB-405-553-DS-13	Ventilation Fan Calculation
TB-405-553-DS-14	BOQ – Ventilation system
TB-405-553-MAN-01	O&M Manual for Air Conditioning & Ventilation System
	Cable schedule for complete Air conditioning and Ventilation system



CLIENT – SJVN ARUN-III POWER DEVELOPMENT COMPANY (P) LTD. (SAPDC)
CONSULTANT- SJVN LTD.
PROJECT: 4x225MW ARUN-III, HYDRO ELECTRIC PROJECT, NEPAL
TECHNICAL SPECIFICATION FOR AIR CONDITIONING & VENTILATION SYSTEM

TB-405-553-001

Rev. 00

Page | 1

SECTION-5 ENCLOSURES TO SPECIFICATION

SCHEDULES TO BE FILLED UP BY THE BIDDER

- Schedule 1 **Schedules of Deviations**
 - Schedule 2 **Details of contact persons (technical & commercial)**
 - Schedule 3 **Schedule of Guaranteed technical particulars**
 - Schedule 4 **Schedule of recommended spares**
 - Schedule 5 **Enclosures to Specification**
- Annexure: Drawings and Documents



CLIENT – SJVN ARUN-III POWER DEVELOPMENT COMPANY (P) LTD. (SAPDC)
 CONSULTANT- SJVN LTD.
 PROJECT: 4x225MW ARUN-III, HYDRO ELECTRIC PROJECT, NEPAL
 TECHNICAL SPECIFICATION FOR AIR CONDITIONING & VENTILATION SYSTEM

TB-405-553-001

Rev. 00

Page | 2

_SCHEDULE-1**SCHEDULE OF TECHNICAL DEVIATION**

The following are the deviations / variations / exceptions from the specification:

Section	Clause No. / Page No.	Statement of deviation/ Variations/Exceptions
---------	--------------------------	--

- 1) **In case, this schedule is not submitted, it will be presumed that the equipment /material to be supplied under this contract are deemed to be in compliance with the specification.**
- 2) If there is NIL deviation, even then the format to be filled as **NIL DEVIATION**
- 3) Continuation sheets of like size and format may be used as per the Bidder's Requirement and shall be annexed to this schedule.

Place _____ Signature of the authorized representative of Bidder

Name -----

Date _____ Designation-----

Company seal-----



CLIENT – SJVN ARUN-III POWER DEVELOPMENT COMPANY (P) LTD. (SAPDC)
 CONSULTANT- SJVN LTD.
 PROJECT: 4x225MW ARUN-III, HYDRO ELECTRIC PROJECT, NEPAL
 TECHNICAL SPECIFICATION FOR AIR CONDITIONING & VENTILATION SYSTEM

TB-405-553-001

Rev. 00

Page | 3

SCHEDULE-2

DETAILS OF CONTACT PERSON BOTH TECHNICAL AND COMMERCIAL

Name

Address for correspondence

Phone No.

Fax No.

Email

Place

Signature of the authorized representative of Bidder

Date

Name-----

Designation-----

Company seal -----

Note:

Continuation sheets of like size and format may be used as per the Bidder's Requirement and shall be annexed to this schedule.



CLIENT – SJVN ARUN-III POWER DEVELOPMENT COMPANY (P) LTD. (SAPDC)
 CONSULTANT- SJVN LTD.
 PROJECT: 4x225MW ARUN-III, HYDRO ELECTRIC PROJECT, NEPAL
 TECHNICAL SPECIFICATION FOR AIR CONDITIONING & VENTILATION SYSTEM

TB-405-553-001

Rev. 00

Page | 4

**SCHEDULE-3
 SCHEDULE OF GUARANTEED TECHNICAL PARTICULARS**

(TO BE FILLED IN BY THE BIDDER)

1. VENTILATION FANS/BLOWERS AND EXHAUST FANS

- i) Type of fan
- ii) Name of manufacturer
- iii) Model Number

2. INDUCTION MOTORS FOR VENTILATION FANS/BLOWERS AND EXHAUST FANS

- i) Type of fan
- ii) Name of manufacturer
- iii) Model Number

3. FILTERS

- i) Name of Manufacturer
- ii) Model No.

4. METAL AIR DUCTS

- i) Manufacturer's name
- ii) Material of construction

5. DAMPERS

- i) Type
- ii) Name of Manufacturer
- iii) Make of Motors

6. GRILLES/DIFFUSERS

- i) Name of Manufacturer
- ii) Model no

7. CONTROL PANEL

- i) Switchgear designation.
- ii) Total dimensions (LxWxH)
- iii) Bus bar continuous rating under site conditions.
- iv) Circuit breakers.
 - a) Name of manufacturer
 - c) Circuit breaker type (air break or MCCB)

8. Air conditioners of each type

- i) Type
- ii) Name of manufacturer.
- iii) Model Number

Place

Signature of the authorized representative of Bidder

Date

Name-----

Designation-----

Company seal -----

Note : For items not listed above but mentioned in the contract required to complete the system, contractor has to submit the performance/ compliance certificate before supply.



CLIENT – SJVN ARUN-III POWER DEVELOPMENT COMPANY (P) LTD. (SAPDC)
 CONSULTANT- SJVN LTD.
 PROJECT: 4x225MW ARUN-III, HYDRO ELECTRIC PROJECT, NEPAL
 TECHNICAL SPECIFICATION FOR AIR CONDITIONING & VENTILATION SYSTEM

TB-405-553-001

Rev. 00

Page | 5

SCHEDULE-4

SCHEDULE OF RECOMMENDED SPARES

S.No.	Description	Quantity

Place

Signature of the authorized representative of Bidder

Name -----

Date

Designation-----

Company seal-----



CLIENT – SJVN ARUN-III POWER DEVELOPMENT COMPANY (P) LTD. (SAPDC)
 CONSULTANT- SJVN LTD.
 PROJECT: 4x225MW ARUN-III, HYDRO ELECTRIC PROJECT, NEPAL
 TECHNICAL SPECIFICATION FOR AIR CONDITIONING & VENTILATION SYSTEM

TB-405-553-001

Rev. 00

Page | 6

SCHEDULE –5

ENCLOSURES TO SPECIFICATION

ANNEXURES

1. Manufacturing Quality Test Assurance Requirements
2. Field Quality Test Assurance Requirements
3. Export worthy Packing
4. Quality and Inspection Formats

DRAWINGS

1. ***Conceptual Layout of CRP Room in Switchgear Building of 400kV Switchyard of Arun 3 HEP - TB-3-405-316-021-Rev06***
2. ***400kV GIS Layout (Plan, Section & Isometric View) – TB-405-317-10-2-Rev02.***
3. ***Electrical Layout Plan and Section of 4x225MW of Arun-3 HEP – TB-3405-316-001-Rev07***
4. ***Crane Clearance Diagram - TB-CCD-405-563-221-Rev01***

 Manufacturing Quality Assurance Test Requirements			
Project Name (MW): ARUN-III HEP (4X225 MW)		Doc. No.: QAI/A/M/EM/HVAC/01	Rev. No.: 02
Item Description: HVAC System		Issue Date: 30.05.2017	Pages.: 3
Sr. No.	Component, Operation & Characteristics	Applicable Standard	Remark
1	2	3	4
A	Split Type/ Cassette Type Air Conditioners		
1	Make, Type & Rating, Functional Test	TS/DRG/ REL STD	V
2	Load Capacity	TS/DRG/ REL STD	V
B	Ventilation Fans		
1	Incoming Material		
1.1	Scroll Casing, Impeller, Shaft, Shaft Sleeves, Base Plate		
	Visual & Dimensional Check, Chemical & Mechanical Properties	TS/DRG/ REL STD	V
1.2	Anti- Vibration Pads		
	Type, Vibration Level	TS/DATASHEET/DRG/ REL STD	V
1.3	Motor		
	Make & Rating, Type Test, Routine Tests	IS 325	V
2	In process Inspection		
2.1	Scroll Casing		
	Dimensional Check, NDT of Weld Joints	TS/DRG/ REL STD/ ASME Section V & VII	V
2.2	Impeller		
	Dimensional Check, NDT of Weld Joints, Balancing (Static & Dynamic)	TS/DRG/ REL STD/ ASME Section V & VII	V
2.3	Shaft		
	NDT of Weld Joints	TS/DRG/ REL STD/ ASME Section V & VII	V
3	Final Inspection		
3.2	Acceptance Test	IS 4894	
	High Voltage test, Insulation Resistance, Earthing Continuity, Electrical Input, Fan Speed, Noise & Vibration Level	IS 4894	W
3.3	Routine Test		
	Flash Test, Insulation Resistance, Run test to determine the functionality of the fan	IS 4894	W
C	Exhaust fans		
1	Raw Material Stage		
1.1	Raw Material Casing/ Fan Base		
	Physical Check, Zinc Coating, Visual & Dimensional Check	IS 277	V
1.2	Motor		
	Type, Model	IS 325	V
1.3	Impeller		
	Type, Dimensional check	TS/DATASHEET/DRG/ REL STD	V
1.4	Anti- Vibration Pads		
	Type, Vibration Level	TS/DATASHEET/DRG/ REL STD	V
2	Inprocess Inspection		
2.1	Fan Casing Roll Forming		
	Visual & Dimensional Check	TS/DATASHEET/DRG/ REL STD	V
2.2	Weld Casing		
	Welding	AWS-ASTM-4	V
2.3	Flanging & Punch Flange Holes		
	Dimensional check	TS/DATASHEET/DRG/ REL STD	V
2.4	Fan Base Fabrication		
	Visual & Dimensional Check	TS/DATASHEET/DRG/ REL STD	V
2.5	Impeller Balancing		
	Unbalance	TS/DATASHEET/DRG/ REL STD	V
2.6	Complete Fan Assembly		
	Visual & Dimensional Check	TS/DATASHEET/DRG/ REL STD	V
2.7	Vibration Test		
	Vibration Level	TS/DATASHEET/DRG/ REL STD	V
3	Final Inspection		
3.1	Axial Type Exhaust fans (fully assembled)		
3.1.1	Routine Test		
	Flash Test, Insulation Resistance, Simple Running Test, Noise Free Operation	IS 3588	W

3.1.2	Acceptance Type		
	High Voltage, Insulation Resistance, Earthing Continuity, Electrical Input, Fan Speed	IS 3588	W
3.2	Propellor Type Exhaust Fans		
3.2.1	Routine Test		
	Flash Test, Insulation Resistance, Simple Running Test, Noise Free Operation	IS 2312	W/V
3.2.2	Acceptance Type		
	High Voltage, Insulation Resistance, Earthing Continuity, Electrical Input, Fan Speed	IS 2312	W/V
3.2	Pre-Dispatch Inspection		
	Packing	TS/ TS/DRG/ REL STD	V
D	Electric Panel		
1	Raw Material		
1.1	CT, PT & control transformers	TS/DATASHEET/DRG/ REL STD	V
	Routine & Acceptance tests		
1.2	ACB, MCCB, MCB, Contactors, Relays	TS/DATASHEET/DRG/ REL STD	V
	Routine & Acceptance tests		
1.3	Bus Bar	TS/DATASHEET/DRG/ REL STD	V
	Material Test, Dimension Check		
1.4	Meters		
	Make, Model & Type and Calibration certificates of all meters	TS/DATASHEET/DRG/ REL STD	V
2	Final Inspection		
	Dimension check for height, width, depth & sheet thickness of panel	Datasheet/ TS/DRG/ REL STD/ IEC 60204-1/ IEC 62271-203	W
	Dimension check of bus bar	Datasheet/ TS/DRG/ REL STD/ IEC 60204-1/ IEC 62271-203	W
	Visual check as per OGA, TS/DRG/ REL STD & verification of BOM	Datasheet/ TS/DRG/ REL STD/ IEC 60204-1/ IEC 62271-203	W
	Verification of correct wiring, Ferruling, dressing, routing, bunching	Datasheet/ TS/DRG/ REL STD/ IEC 60204-1/ IEC 62271-203	W
	continuity check, colour coding and earthing	Datasheet/ TS/ DRG/ REL STD/ IEC 60204-1/ IEC 62271-203	W
	Insulation resistance measurement before & after HV test	Datasheet/ TS/ DRG/ REL STD/ IEC 60204-1/ IEC 62271-203	W
	Dielectric tests on auxiliary and control circuits	Datasheet/ TS/ DRG/ REL STD/ IEC 60204-1/ IEC 62271-203	W
	Functional test on all AC & DC circuit including heating, Lighting, Fan & thermostat	Datasheet/ TS/ DRG/ REL STD/ IEC 60204-1/ IEC 62271-203	W
	Operational & functional test	Datasheet/ TS/DRG/ REL STD/ IEC 60204-1/ IEC 62271-203	W
	Verification of IP Class	Datasheet/ TS/DRG/ REL STD/ IEC 60204-1/ IEC 62271-203	W
	Surface Protection coating, Paint Shade & Finish, Adhesion test	Datasheet/ TS/DRG/ REL STD/ IEC 60204-1/ IEC 62271-203	W
E	Auxiliary System and Misellenous Components		
1	Incoming Material		
1.1	Air Ducts		
1.1.1	Ducting Sheets		
	Visual & Dimensional Check, Chemical & Mechanical Properties	TS/DRG/ REL STD/ IS 655/ IS 277/ IS 737	V
1.1.2	Supporting Channels/ Rods		
	Visual & Dimensional Check, Chemical & Mechanical Properties	TS/DRG/ REL STD	V
1.2	Filters		
	Visual & Dimensional Check, Filter frame Material Test Certificate, Support Mesh, Metal Casing Material Test Certificate	TS/DRG/ REL STD/ IS 737	V
	Efficiency test, Pressure Drop Vs Flow, Sodium Flame test	IS 7613, BS 3928	W
1.3	Temperature & Humidity Sensors		
	Functional Test	TS/ DRG/ REL STD	V
1.4	Splitters & Duct Damper, Fire Damper		
	Visual & Dimensional Check, Movement of louver and damper blades, Electrical actuator for fire dampers	TS/DRG/ REL STD	V
1.5	Plenum		
	Mechanical & Chemical Properties of material	TS/DATASHEET/DRG/ REL STD	V
1.6	Insulation Material		
1.6.1	Glass wool/ Expanded Polystyrene		
	Visual & Dimensional Check, Chemical & Mechanical Properties, Thickness, Density	TS/DRG/ REL STD/IS 3069/ IS 4671	V

1.6.2	Sheet/ Coils for cladding Aluminium Material		
	Visual & Dimensional Check, Chemical & Mechanical Properties	TS/DRG/ REL STD	V
1.7	Grills & Diffusers		
	Visual & Dimensional Check, Functional test	TS/DRG/ REL STD	V
1.8	Outside Air Louvers		
	Visual & Dimensional Check, Chemical & Mechanical Properties	TS/DRG/ REL STD	V
1.9	Piping Material: Pipes/ Pipe fittings/ flanges		
	Visual & Dimensional Check, Chemical & Mechanical Properties	TS/DRG/ REL STD	V
LEGENDS			
TS: TECHNICAL SPECIFICATIONS		REL. STD.: RELEVANT STANDARD	
V: VERIFICATION OF REPORTS/TCs		DRG: DRAWING	
W: CUSTOMER HOLD POINT (CHP)			
NOTES			
1	Any test at any stage not covered in Quality Assurance Test Requirement (QATR), but part of technical specification of contract, shall also be carried out by Contractor/ firm.		
2	QATR shall be read in conjunction with General Quality Assurance Requirement given as part of Technical Specification		
W/V	The final testing for exhaust fans shall be witness (CHP) for rating above 2500 CMH and TC Review for rating below 2500 CMH		

 Field Quality Assurance Test Requirements			
Project Name (MW): ARUN-III HEP (4X225 MW)		Doc. No.: QAI/A/F/EM/HVAC/01	Rev. No.: 02
Item Description: HVAC System		Issue Date: 30.05.2017	Pages.: 1
Sr. No.	Component, Operation & Characteristics	Applicable Standard	Remark
1	2	3	4
1	Receipt of Material & Storage		
1.1	Electric Fans, Motors, Filters, Air Ducts, Splitters Dampers, Plenums, Diffusers, Grills etc		
	External conditions of equipment free from damage, Proper placement of equipment as per Instruction Manual, Ensure that no damage of rusting takes place during storage, Ensure that all delicate instruments are stored in protected area	TS/DRG/ REL STD	W*
2	Pre Erection/ Erection Check		
2.1	Electric Fan		
	System No./ Equipment No., Orientation/ Direction of rotation, Motor rating & IR test before erection, Impeller No, Fixing/ grouting of casing, Check for secureness. Tightness of all fixing bolts/ nuts, No load running of motor, Locking of impeller on motor, check for provision of accessories	TS/DRG/ REL STD	W*
2.2	Filters		
	Proper levelling, alignment & fixation	TS/DRG/ REL STD	W*
2.3	Finished Air Ducts		
	Visual check for surface defects, Final Dimensional check, Installation of ducts as per Drawing, Check for Tightness, Vibration and Noise due to turbulence, Fixing of support of ducts as per drawing	TS/DRG/ REL STD	W*
2.4	Finished Grills		
	Visual check for surface defect, louver movement check, Proper levelling, alignment	TS/DRG/ REL STD	W*
2.5	Finished Dampers & Splitters		
	Visual check for surface defect, Final Dimensional check, Functional check, Proper levelling, alignment	TS/DRG/ REL STD	W*
2.6	Panels		
	Proper alignment, Leveling and location, Earthing continuity, Cable Glanding & termination	TS/DRG/ REL STD	W*
3	Pre Commissioning Checks		
3.1	Electric Fan		
	Noise & Vibration Check, IR Check, Free rotation check, Direction of rotation	TS/DRG/ REL STD	W*
3.2	Panels		
	IR test, Earthing, Paint shade & finish, Functional test	TS/DRG/ REL STD	W*
3.3	Motorised Air Dampers		
	Functional test, Dimensional check & visual check	TS/DRG/ REL STD	W*
3.4	Test during Pre Commissioning		
	Dielectric and insulation resistance on all electrical circuits	TS/DRG/ REL STD	W*
	Tests to verify electrical ratings	TS/DRG/ REL STD	W*
4	Commissioning test		
4.1	Complete Ventilation and Air Conditioning System		
	General Running Test	TS/DRG/ REL STD	W*
	Pressure Test or Leakage Test	TS/DRG/ REL STD	W*
	Checking of air velocity at different locations	TS/DRG/ REL STD	W*
	Checking for abnormal noise and vibrations	TS/DRG/ REL STD	W*
	Capacity Rating Test	TS/DRG/ REL STD	W*
	Power Consumption Test	TS/DRG/ REL STD	W*
	Functional test of air conditioner in respect of temperature and humidity	TS/DRG/ REL STD	W*
	Test to verify the dust holding capacity of air filters	TS/DRG/ REL STD	W*
5	Performance Test	TS	W*
LEGENDS			
TS: TECHNICAL SPECIFICATIONS		REL. STD.: RELEVANT STANDARD	
V: VERIFICATION OF REPORTS/TCs		DRG: DRAWING	
W: CUSTOMER HOLD POINT		W*: WITNESS BY SAPDC/ MAIN CONTRACTOR	
NOTES			
1	Any test at any stage not covered in Quality Assurance Test Requirement (QATR), but part of technical specification of contract, shall also be carried out by Contractor/ firm.		
2	QATR shall be read in conjunction with General Quality Assurance Requirement given as part of Technical Specification		
3	Responsibility for witnessing (W*) at site shall be decided mutually at the time of finalization of FQAP as per the criticality of test.		

Annexure F - Export-Worthy Packing

1.0 SCOPE:

For export jobs, sea worthy packing capable of performing all necessary functions like prevention of damage to the contents, sufficient to support frequent handling and lengthy periods of outdoor storage in adverse weather conditions are required. Workmanship and material used shall meet the technical requirements and be in accordance with best commercial export packing practices. Vendor shall be responsible for the packing, however, it shall meet the minimum requirements specified herein. Equivalent or better packing methods may be deployed subject to approval of the purchaser. Vendor shall submit the packing procedure for its equipment for purchaser's approval during detailed engineering.

2.0 TECHNICAL SPECIFICATION OF WOOD:

The wood shall be Fir, Chir, Silver Oak (*Grevillea Robusta*) or chemically treated mango with moisture content not exceeding 50 %. The wood shall have flexural & compressive strength, stiffness, shock absorption and nail retention properties. The wood shall be free from common defects such as warp, bone, twist, knot, cracks, splits, end splits, bend, visible sign of infection and any kind of decay caused by insects, fungus etc. Surface cracks with a maximum depth of 3 mm are permissible. A continuous crack of any depth all along the length is not allowed.

The wood shall be chemically treated to provide protection against deterioration due to fungi and attack by termites, borers, marine organism and any other kind of infection. It shall be treated only after final processing like cutting, planing, joint grooving etc.

3.0 TYPE, DESIGN & DIMENSION OF WOODEN PACKING CASES:

3.1.1 PACKING OF EQUIPMENTS:

Various mechanical, electrical and C&I equipment e.g. pumps, motors, equipment skids, heat exchangers, control panels, switch gears, transformers etc. shall be wrapped in weather proof packing and then secured in wooden packing cases. The construction of wooden packing cases shall be as per details given below and also in figures 1 to 11.

3.1.1 BOTTOM FRAME:

The construction of bottom frame shall be as per fig. 2. The number of slides/runners for bottom frames shall be selected depending upon the weight and overall dimension of the load to be carried. The equipment shall be secured by fixing their base frame/plate with the help of bolt & nuts etc to the bottom frame of the wooden packing cases. The equipment not provided with the base frame/plate like

705358/2022/TBG-TB_ENG_SR

cylindrical vessels etc. to be secured to the bottom frame of the wooden case with 'C' clamps fabricated from steel channels/angle irons.

3.1.2 TOP FRAME:

The construction of top frame shall be as per fig. 3.

3.1.3 END PANELS:

The dimensions of the end and lateral panels shall be calculated according to overall dimensions of the items to be packed.

Diagonal braces shall be used for packing cases having height exceeding 500 mm. Detail of bracing shall be as per figure 5 to 8.

3.1.4 SLING PLATE:

To facilitate lifting of cases, longitudinal under slide boards shall be fixed. To avoid damage to the box while lifting sling plates shall be provided. Refer fig. 11.

3.1.5 ANGLE IRON CLEATS :

Angle iron cleats shall be used for strengthening the joints as indicated in fig. 10.

3.1.6 OTHER REQUIREMENTS:

The thickness of planks for top, bottom, side and end panels shall be at least 25 mm. Planks used for this purpose shall be joined with each other by tongue & groove joint. The groove dimension shall be such that tongue fits tightly into groove to make good joint.

Runners/slides, traverse bars etc. shall be of single length i.e. without any joint. Planks for sheathing, diagonal bracing etc shall also be of single length upto 2400 mm. For sizes larger than 2400 mm, proper jointing is permitted for planks for sheathing and diagonal bracing.

Each equipment to be individually covered with double polyethylene petticoat. Sheet thickness of polyethylene sheet shall not be less than 0.175 mm (175 microns). The sealing shall be such so as not to allow moisture inside.

The inner surface of 4 sides of shooks shall be nailed with bituminised water proof kraft paper. Wherever 2 pieces of kraft paper are used, the joint shall have an overlap of minimum 20mm.

All the inner sides of the box shall be nailed with bitumen coated hessian polyethylene kraft paper. For top frame it shall project on all sides by 100mm and shall be nailed on sides. Wherever 2 pieces of kraft paper are used, the joint shall have an overlap of minimum 20mm.

705358/2022/TBG-TB_ENG_SR

For delicate equipment like control panels, switchgears etc suitable cushioning material like rubberized coir shall be provided on their bottom support. The thickness of coir shall be 50 mm (minimum) and width 100 mm (minimum).

For control panels and switchgears, the gap between the panel and casing shall be filled with rubberized coir with distance between consecutive supports less than 500 mm (ref fig 15). For other equipment suitable support from sides of the casing to be provided.

Switchgear cubicles, control panels and control desks shall be packed and shipped in separate convenient sections. The components e.g. circuit breakers relays and instruments etc. which are removed from panels for shipping purpose shall be separately packed and shipped as per packing instructions in clause 3.2.

Packing case for control panels & switchgear panels shall be finally covered with GI sheet of minimum thickness of 0.4 mm.

Packing cases shall be bound at edges by nailing MS clamps/brackets at sufficient intervals. Further, heavier boxes shall be strapped with 'C' clamps (ref fig 4) fabricated from steel channels/angles and lighter boxes shall be strapped with hoop iron strips.

3.1.7 ALTERNATIVE PACKING CASES FOR CONTROL PANELS AND SWITCHGEARS

If required, for control and switchgear panels, construction of wooden packing cases may be provided as per fig 14 & 15 and as detailed below:

Thickness of planks for all sides, binding and jointing battens shall be atleast 25 mm. Width of planks shall be at least 125mm and that of binding and jointing planks shall be at least 100 mm.

Top frame shall be suitable so that it does not collapse due to sandwiching between slings while lifting. Longitudinal and traverse bars for the bottom wooden pallet to be suitably selected.

Diagonal bracings shall be as per clause 3.1.3 and All other requirements shall be as per clauses 3.1.4 to 3.1.6.

3.2 PACKING OF LOOSE ITEMS:

Loose mechanical, electrical and C&I items eg valves, fittings, pressure/temperature gauges/switches, circuit breakers, relays etc shall be individually wrapped using polyethylene sheets/U foam/thermocole sheets/air bubbled sheets depending upon the item and then packed in wooden boxes. The left out spaces and top of the boxes shall be filled with rubberized coir to get proper cushioning effect. Special attention is to be paid to relays, instruments etc for arresting the movement of their operating mechanisms during transportation.

The construction of wooden packing case shall be as per clause 3.1 retaining its all features concerning strength of box. The construction of wooden packing case for loose electrical and C&I items shall be as per fig. 16.

Inner surface of 6 sides of the box shall be lined with Bitumen coated hessian polyethylene kraft paper. Rubberized coir of min. 25 mm thickness and 100 mm width shall be nailed to inner surfaces of bottom and 4 sides of the box.

Loose items such as Galvanised Steel Structure, Cable support racks, Cable Trays and GI Pipes etc. shall be individually wrapped using polyethylene sheets and further lots may be wrapped in Bitumen coated hessian cloth.

4.0 MOISTURE ABSORBER:

Silica gel is used for this purpose to protect contents over sufficiently long time from corrosion. Silica gel shall be of indicating type conforming to IS-304-1979 packed in cotton bags placed at different positions inside the packing for absorbing moisture and shall not come directly into contact with the equipment / material inside the package. The quantity of silica gel shall be enough for storage period of one (1) year, however, it shall not be less than 4 gms per litre volume of case subject to minimum of 400 gms per case.

5.0 INDICATION MARKS ON THE BOXES:

Markings shall be provided on the boxes indicating position of boxes for handling, storage and nature of consignment. For guidelines refer figure 12. The ink used for this purpose as well as for marking despatch instruction shall be indelible/nonwashable marking ink.

6.0 DESPATCH DETAILS:

External front and rear sides of the boxes to be planed for writing instructions.

Dispatch details such as consignor/consignee address, contract and case details, country of origin , port of delivery, stacking instructions shall be written on one of the side of boxes. An anodised aluminium plate shall be provided on one side of the boxes.

One copy of packing slip wrapped in polyethylene bag covered with aluminium packing slip holder to be nailed on the external surface of the box. One more copy of the packing slip wrapped in polyethylene bag to be kept inside the box at the prominent place.

7.0 INSPECTION:

There shall be a Customer Hold Point (CHP) for inspection of final assembly of packing. During above inspection, the records for Chemical Treatment shall be reviewed.

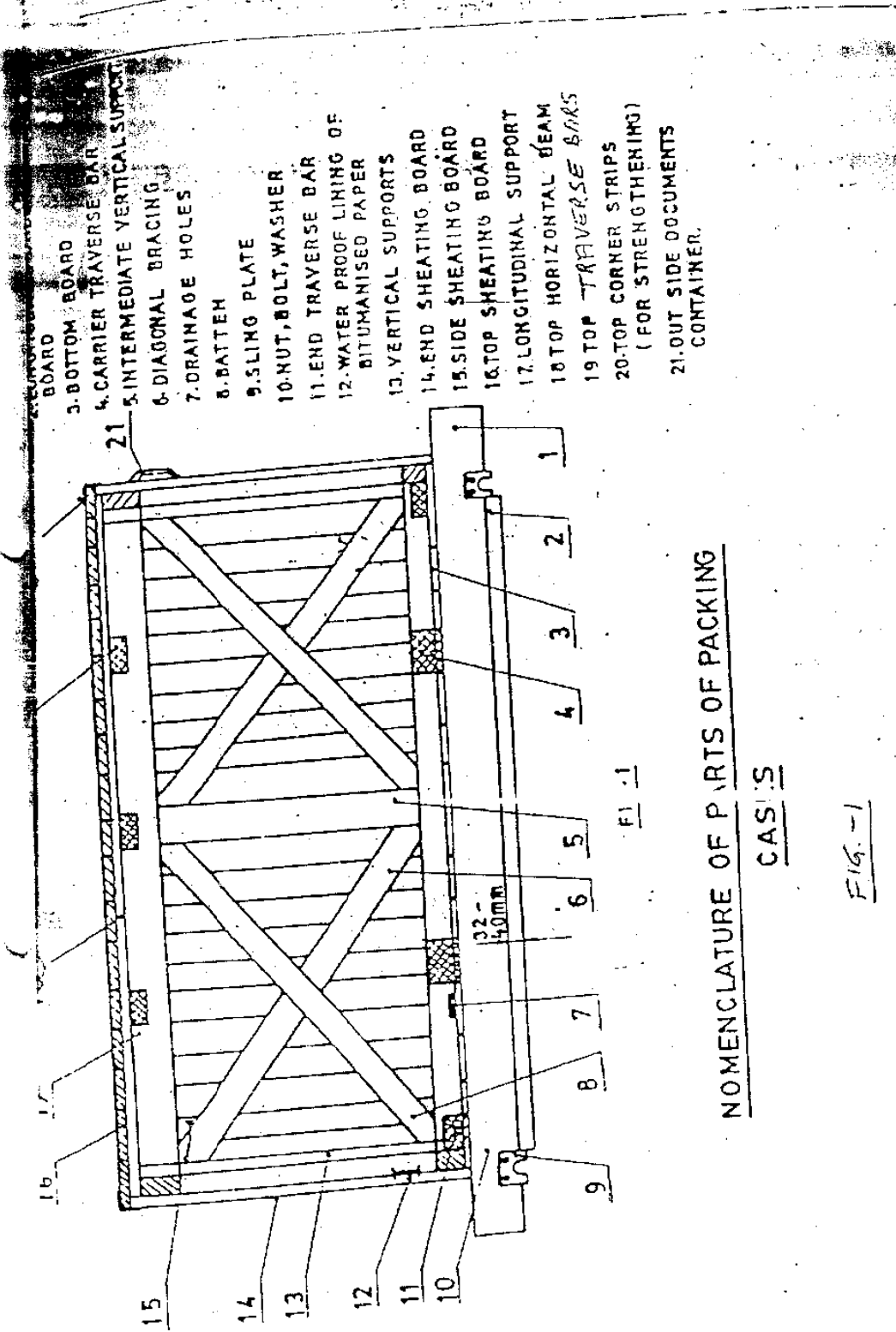

- 1. BOARD
- 2. BOTTOM BOARD
- 3. BOTTOM BOARD
- 4. CARRIER TRAVERSE BAR
- 5. INTERMEDIATE VERTICAL SUPPORT
- 6. DIAGONAL BRACING
- 7. DRAINAGE HOLES
- 8. BATTEH
- 9. SLING PLATE
- 10. NUT, BOLT, WASHER
- 11. END TRAVERSE BAR
- 12. WATER PROOF LINING OF BITUMANISED PAPER
- 13. VERTICAL SUPPORTS
- 14. END SHEATING BOARD
- 15. SIDE SHEATING BOARD
- 16. TOP SHEATING BOARD
- 17. LONGITUDINAL SUPPORT
- 18. TOP HORIZONTAL BEAM
- 19. TOP TRAVERSE BARS
- 20. TOP CORNER STRIPS (FOR STRENGTHENING)
- 21. OUT SIDE DOCUMENTS CONTAINER.

FIG. -1

NOMENCLATURE OF PARTS OF PACKING

CASIS

FIG. -1

EC 009

BOTTOM FRAME ARRANGEMENTS

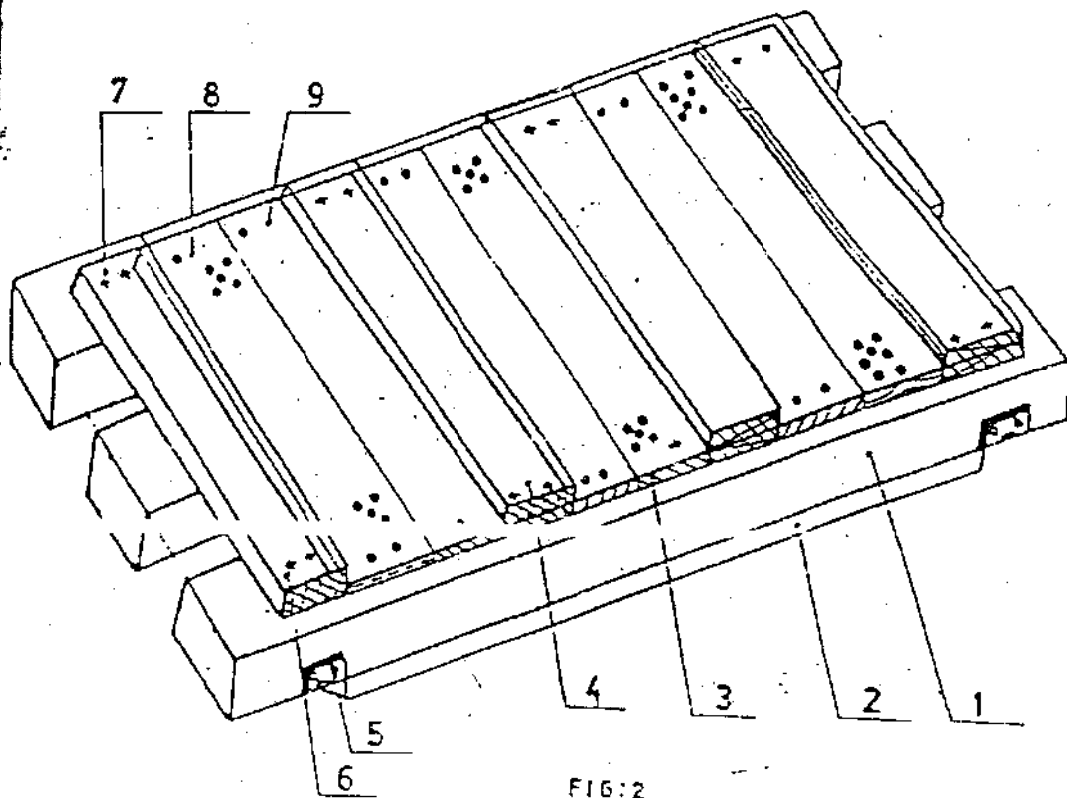

FIG:2

Nos. of slides : Minimum 2 nos.

For length more than 1800 mm or
load more than 1000kg, nos. of
slides shall be minimum 3 nos.

For dimensions of slides, refer Table 1

Cross section of end traverse bar; 100 X 100 mm.
(minimum)

1. SLIDE
2. UNDER SLIDE BOARD
3. BOTTOM BOARD
4. CARRIER TRAVERSE BAR
5. SLING PLATE
6. TRAVERSE BAR
7. BOLT, NUT & WASHER
8. DRAINAGE HOLES
9. NAILS

TOP FRAME ARRANGEMENT

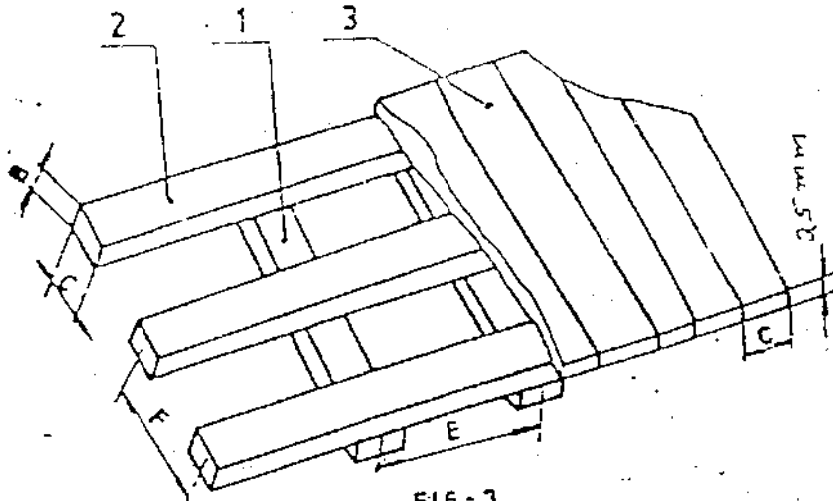

FIG-3

Dim F : 700 to 1000 mm
 Dim E : 500 to 900 mm
 B x C : 30 x 100 mm.

- 1 - Transverse Bars
- 2 - Horizontal Scans
- 3 - Top Board

ARRANGEMENT OF C-CLAMPS AROUND CASES

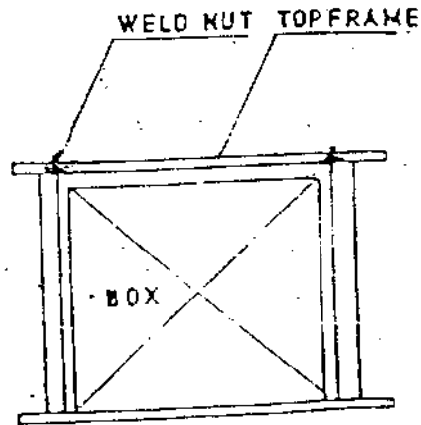
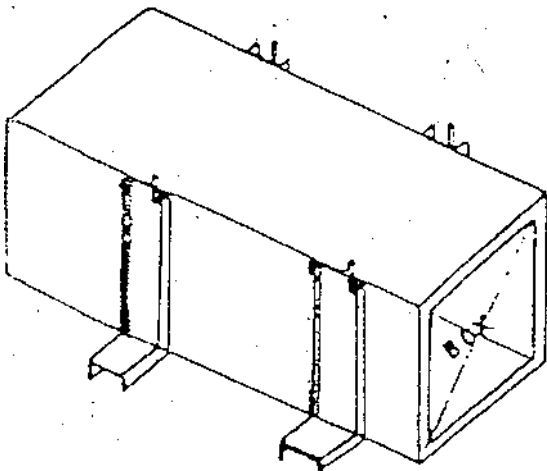

FIG:4

ARRANGEMENT OF DIAGONAL BRACING AND HORIZONTAL SUPPORT

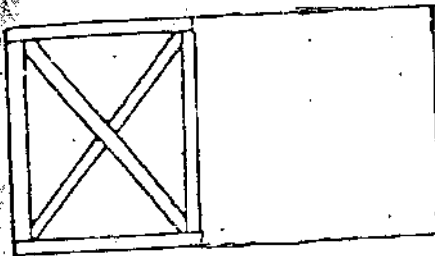

FIG:6

1400 mm TO 1800mm

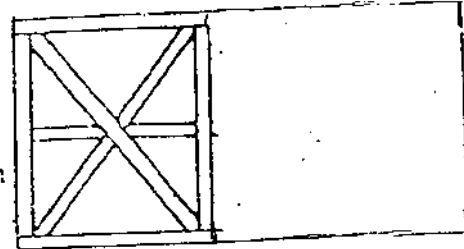

FIG:8

1800mm & ABOVE

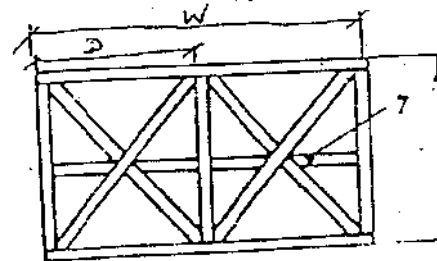

FIG:9

1800mm & ABOVE

7- Middle Horizontal Support

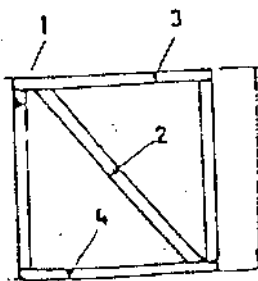

FIG:5

500mm TO 1400mm

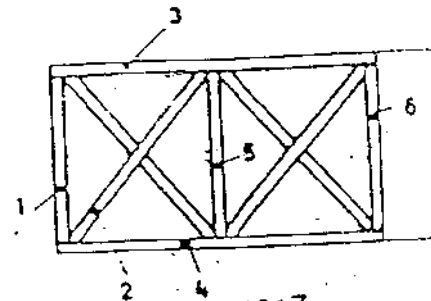

FIG:7

1400mm TO 1800mm

- 1- Vertical Support
- 2- Diagonal Bracing
- 3- Upper Horizontal Support
- 4- Lower Horizontal Support

- 1, 5, 6 - Vertical Support
- 2 - Diagonal Bracing
- 3 - Upper Horizontal Support
- 4 - Lower Horizontal Support

The dimensions of various items shall be as Table-2

ARRANGEMENT OF PACKING CASE

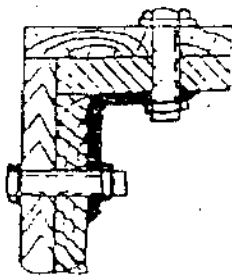
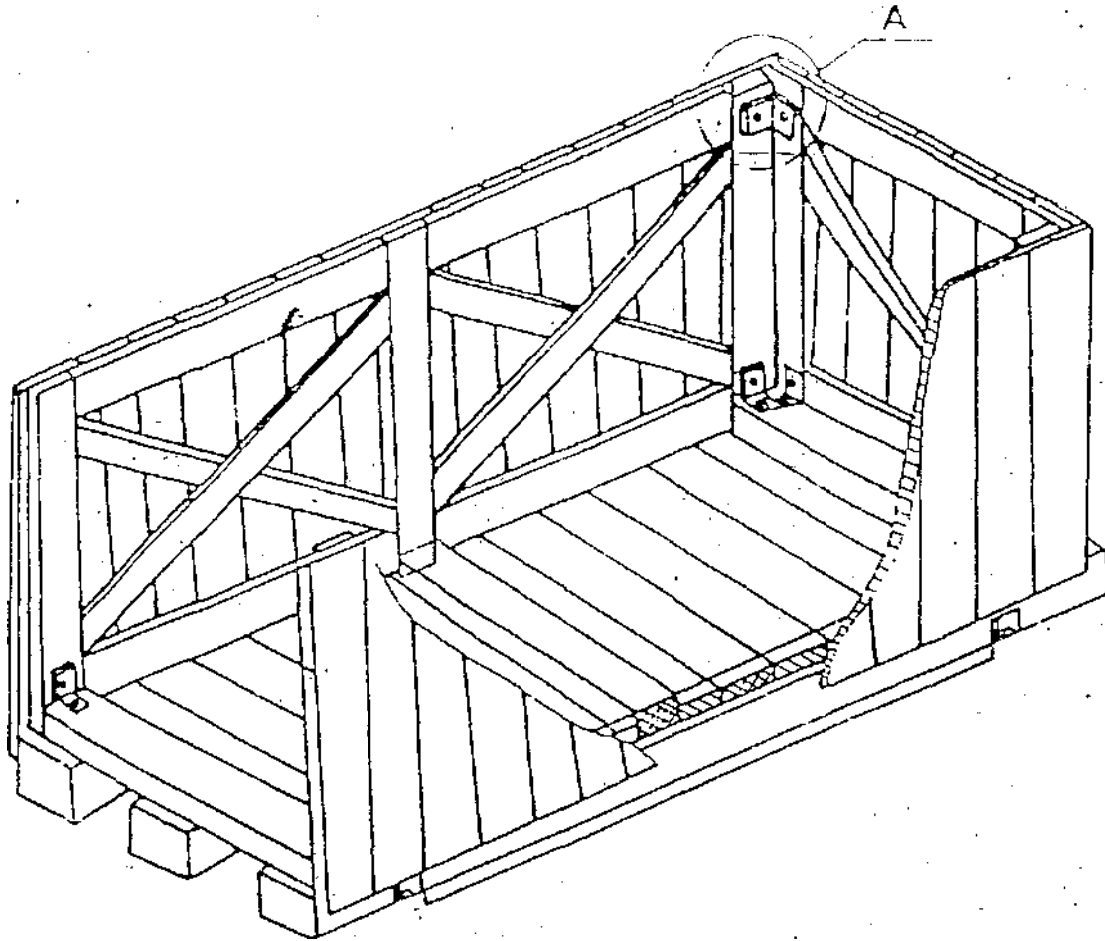

DETAIL-A

HOLE DIAMETER
MUST CONFORM
TO BOLT DIA

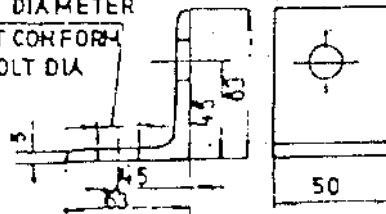

FIG:1D

ARRANGEMENT OF SLING - PLATE ON
CASES

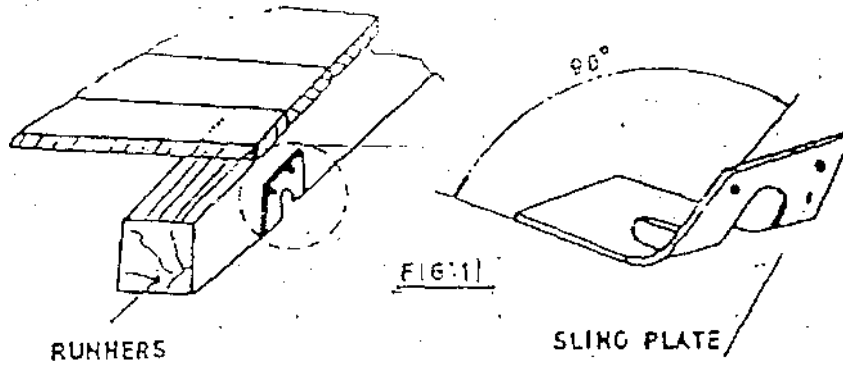
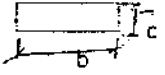

Table 1

load	Length of Slides						
	600	800	1000	1200	1300	1500	2000
	Cross Section b x c 						
500	50 x 100	50 x 100	50 x 100	50 x 100	75 x 100	75 x 100	100 x 100
800	50 x 100	50 x 100	75 x 100	75 x 100	75 x 100	75 x 100	100 x 100
1000	75 x 100	75 x 100	75 x 100	100 x 100	100 x 100	100 x 110	100 x 150
1500	75 x 100	75 x 100	100 x 100	100 x 100	100 x 100	100 x 150	100 x 150
2000	75 x 100	100 x 100	100 x 100	100 x 150	100 x 150	100 x 150	150 x 150
2500	75 x 100	100 x 100	100 x 150	100 x 150	100 x 150	150 x 150	150 x 150
3000	100 x 100	100 x 150	150 x 150	150 x 150	150 x 150	150 x 150	

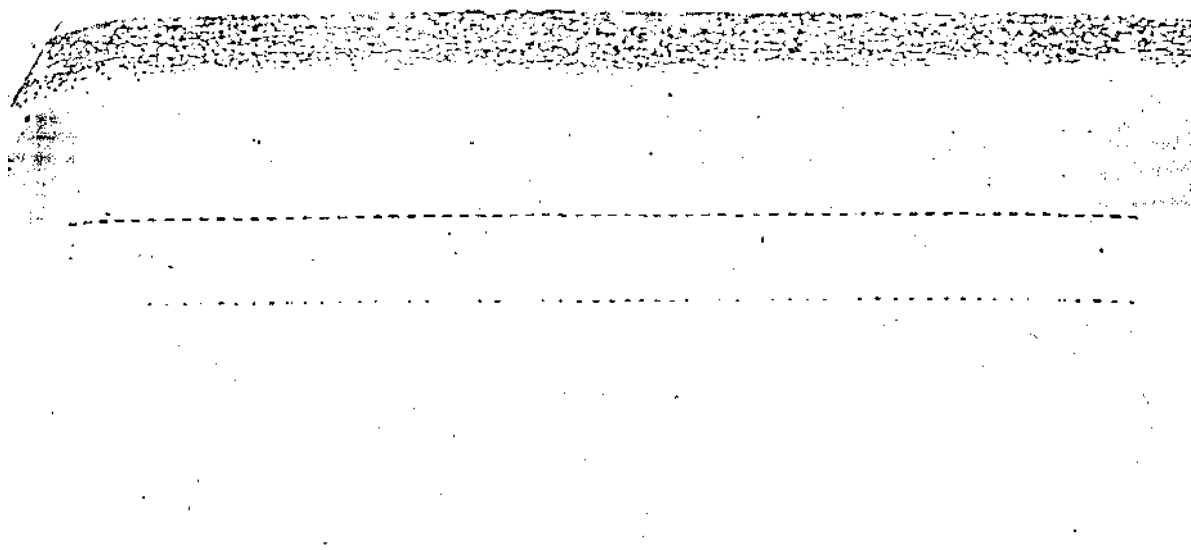







Table 2

End and side Panels	Width of the panel W	Distance between longitudinal support DIM 'D'						
		600	800	1000	1200	1400	1600	1800
		Cross Section (b : c)				Item 1 to 7		
Fig 5 to	600 to 1200	30 x 100	30 x 100	30 x 100	30 x 130	30 x 130	30 x 130	30 x 130
	1201 to 1600	30 x 130	30 x 130	30 x 130	30 x 130	30 x 130	30 x 130	30 x 130
	1601 to 2000	30 x 130	30 x 130	30 x 130	30 x 130	30 x 130	30 x 130	30 x 130
Fig 9	2001 to 3000	30 x 130	30 x 130	30 x 130	30 x 130	30 x 130	30 x 130	40 x 150
	3001 to 4000	30 x 130	30 x 130	40 x 150	40 x 150	40 x 150	40 x 150	40 x 150

INDICATION MARKS ON CASES

SL. NO	INDICATION MARK	MEANING
1		TOP SIDE
2		KEEP AWAY FROM HEAT
3		SLINGING POSITION
4		FRAGILE MATERIAL. HANDLE WITH CARE
5		CENTRE OF GRAVITY
6		KEEP DRY

BHEL-PEM-DEHI-INDIA			
CONSIGNEE		MO. NO.	
MATERIAL		CASE NO.	
CUSTOMER REF.		NET WT -KGS	GROSS WT -KGS
DESPATCH ADVICE NOTE NO.			
DIMENSIONS(MM) LXBXH			
SPECIAL INSTRUCTIONS	HANDLE WITH CARE -- KEEP DRY DO NOT DROP -- DO NOT TILT		

FIG-13: MARKING PLATE.

31

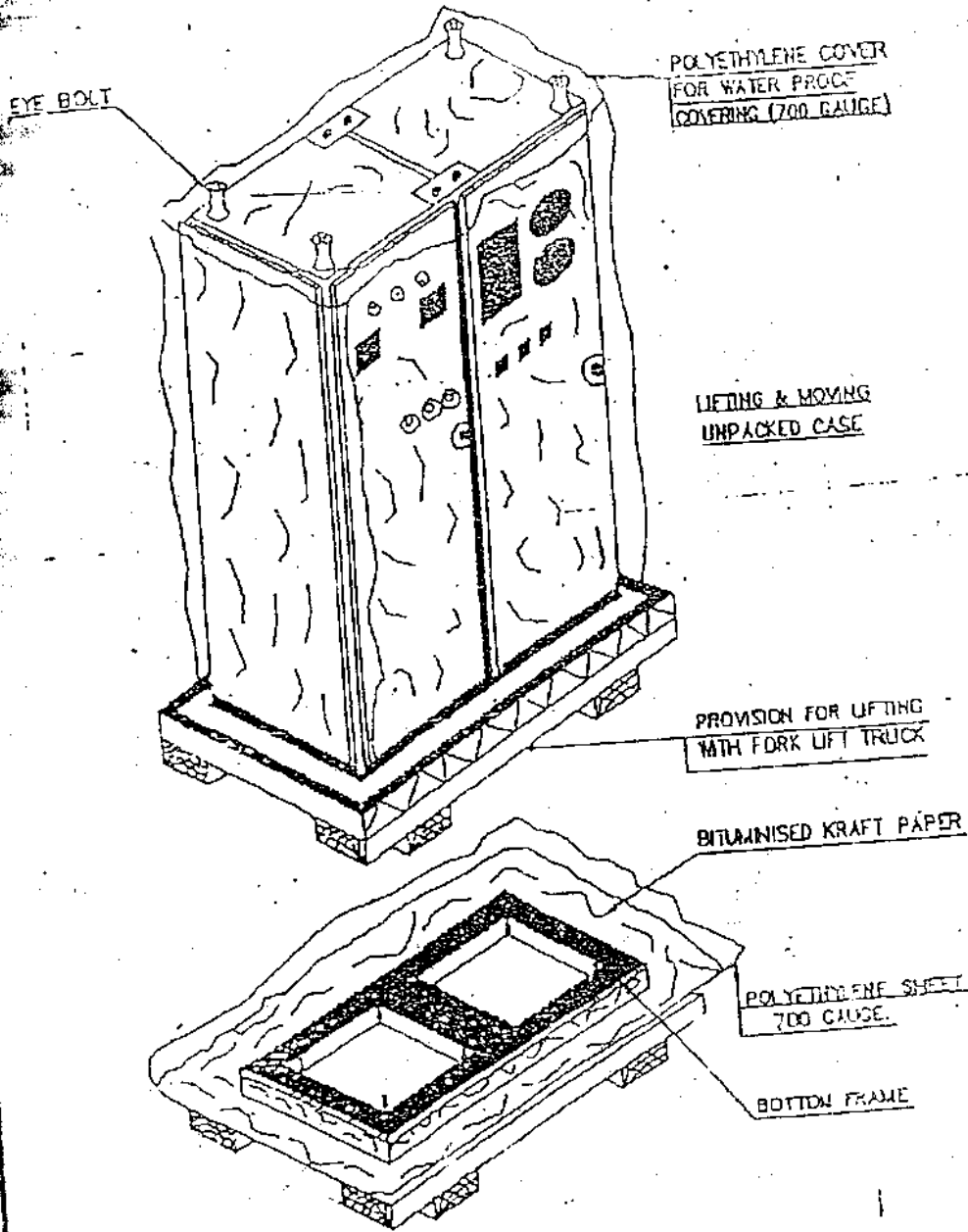

FIGURE-14

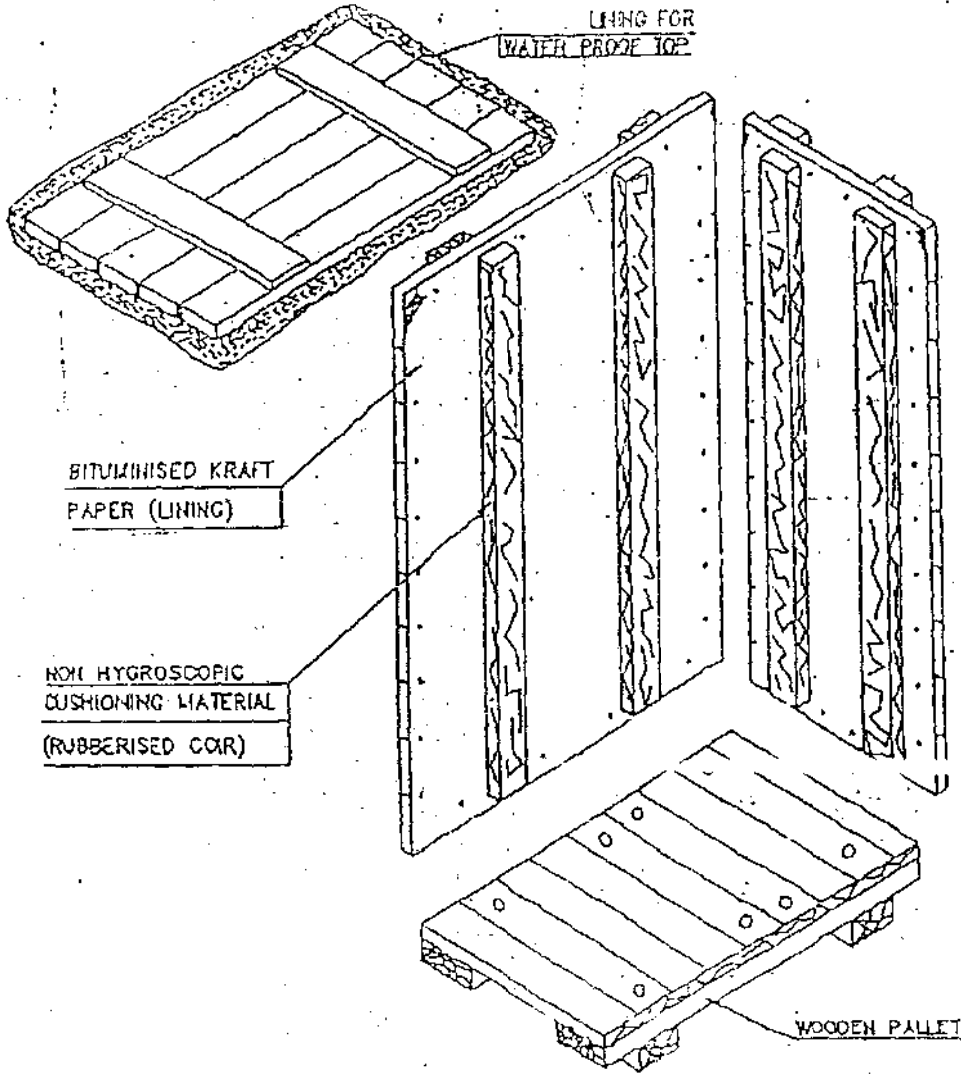

FIGURE-15

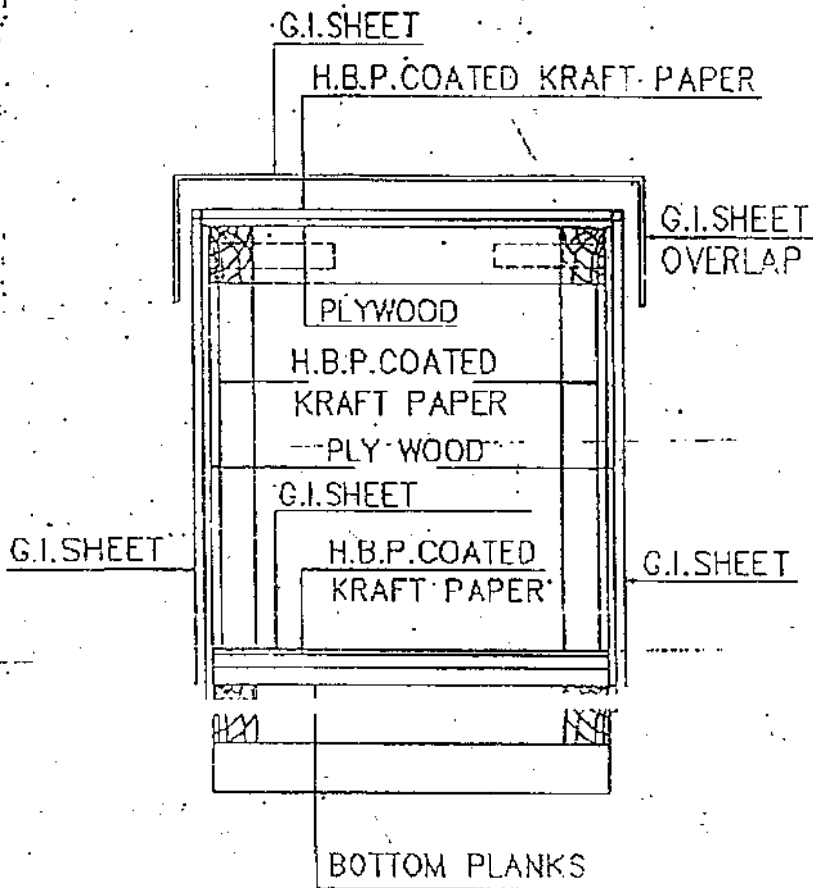



FIG-16 : CLOSED PACKING CASE WITH G.I.SHEET
SHOWING LAYERS OF PACKING MATERIALS.

Annexure –E

QA&I Formats

	SJVN	FORM NO.: F-060-01 PAGE: 1 of 14 ISSUE: 2.0 REV. 01 DATE: 30/06/2016
	FORM	

VENDOR / SUB-VENDOR ASSESSMENT SHEET

TO BE FILLED-IN BY SUPPLIER / SUB-VENDOR

NAME OF SUPPLIER / SUB-VENDOR IN FULL					
REGISTERED OFFICE			FACTORY / WORKS		
ADDRESS					
TELEPHONE NO.					
FAX NO.					
EMAIL ID					
PERSON(S) TO BE CONTACTED (NAME & DESIGNATION & MOBILE NO.)					
WEEKLY OFF					
SHIFT WORKING					
		Type of Company (Pl. Tick)		Type of Industry (Pl. Tick)	
OFFICE	WORKS	Pvt. Ltd	Public Ltd.	MSME	Large Scale
ONE <input type="checkbox"/>	ONE <input type="checkbox"/>	Proprietary <input type="checkbox"/>	Partnership <input type="checkbox"/>	Govt. <input type="checkbox"/>	Contractor <input type="checkbox"/>
TWO <input type="checkbox"/>	TWO <input type="checkbox"/>	Public Sector <input type="checkbox"/>			
THREE <input type="checkbox"/>	THREE <input type="checkbox"/>				

	SJVN	FORM NO.: F-060-01 PAGE: 2 of 14 ISSUE: 2.0 REV. 01 DATE: 30/06/2016
	FORM	

Sr. No.	Items / Services / Process for which Approval is desired for	Rating / Size & Type	Applicable Standards IS/DIN/BS/IEC Etc.

REGISTRATION DETAILS #

PAN / TAN NO.	CENTRAL SALES TAX REG. NO.	STATE SALES TAX / TIN NO.	EXCISE DUTY REGISTRATION NO.
EXCISE CONTROL CODE NO.	SERVICE TAX REG. NO.	CATEGORY OF INDUSTRY	REGISTRATION NO. & VALIDITY DATE
		Micro <input type="checkbox"/> Small <input type="checkbox"/> Medium <input type="checkbox"/> Large <input type="checkbox"/>	

	SJVN	FORM NO.: F-060-01 PAGE: 3 of 14 ISSUE: 2.0 REV. 01 DATE: 30/06/2016
	FORM	

	SJVN	FORM NO.: F-060-01 PAGE: 4 of 14 ISSUE: 2.0 REV. 01 DATE: 30/06/2016
	FORM	

A. ORGANISATIONAL SOUNDNESS						
Sr. No.	DESCRIPTION		DETAILS TO BE FURNISHED			
1.	Nature of Business (Strike whichever is not applicable)		Manufacturing Unit / Engineering Consultant / Agents / Distributors / Stockists / Dealers / Traders / Indian Subsidiary / EPC contractor / Channel Partner (Attach authorization certificate of principal) / Erection contractor / Other			
2#	Year of commencement of Business / Factory Establishment					
3.	Year of Commencement of Manufacture / Services					
4.	Total Area/Covered Area in Sq. m.		Total Area	Covered Area		
5.	Electric Power-Connected Load					
6#	Electric Power Standby Load & System					
7.	Details of Directors					
Sr. No.	Name	Designation	Qualification	Experience		
8.	Details of Employees					
Please attach copy of Company's Organization Chart (For Unit)						
Division Status	Graduate		Diploma	Skilled	Un-Skilled	Remarks
	Technical	Non-Technical				
Production						
Engineering & Quality Control						
Administration & Other Supporting activities.						

9. Brief Details of Product and Manufacturing Capability					
Sr. No.	Item & Material	Description (Type, Size Rating)	Annual Production for Last Three Years		
			I	II	III
10.#	Details of Foreign or Indigenous Collaborator				
Sr. No.	Product	Name & Address of Collaborator	Collaboration		
			Scope	Year	Valid up to
11#	Have your product been type tested by any external agency? If so, give details				
Sr. No.	Product	Test (Size / Type & class	Test Report No.	Next Due date	

ARUN-III HEP

	SJVN	FORM NO.: F-060-01 PAGE: 5 of 14 ISSUE: 2.0 REV. 01 DATE: 30/06/2016
	FORM	

12.#	Have you been approved by any Statutory agency / third party agency like LLOYD, ASME, NTPC, PGCIL, EIL, Railways etc. ? If so, indicate details and enclose copies of approval letters				
Sr. No.	Item / Material / Service / Process	Description (Size, Type & Class)	Agency	Date of approval	Next Due date
13.#	Indicate Approval / Certification by National / International Standards / Agencies applicable for the subject product.				
Sr. No.	Product	Codes / Standards	License No. & Date		
14.#	Reference List (Experience in Particular Type of Equipment / Service / Process). Please indicate since how many years similar type of item / equipment / service / process provided (please furnish documentary evidence).				
Sr. No.	Item / Material / Service / Process	Type & Capacity / Rating	Customer (End User with Address)	Date of Supply / Service provided	Under Operation since year / Month
<p>#Note: Please furnish the performance feedback certificate for proposed item / equipment / process / service form end user in line with requirement stipulated in Technical Specification.</p>					

	SJVN	FORM NO.: F-060-01 PAGE: 6 of 14 ISSUE: 2.0 REV. 01 DATE: 30/06/2016
	FORM	

15.#	Business Commenced with SAPDC/SJVN in past				
Sr. No.	Year	Name of Department / Project Dealt with	Item Supplied / Services Offered.		
16.A#	Machinery, Instrument & other Equipment Specific to Process & Product Facilities / service				
Sr. No.	Description of Machine	Capacity & Nos.	Location Shop	Make	Year of Manufg.
16.B#	Other General Facilities				
Sr. No.	Description of Machine	Capacity & Nos.	Location Shop	Make	Year of Manufg.
i	Material Handling Mobile Crane Fork Lift Over Head Cranes				
ii	Metal Cutting &				

	SJVN	FORM NO.: F-060-01 PAGE: 9 of 14 ISSUE: 2.0 REV. 01 DATE: 30/06/2016
	FORM	

21 #	Do you have in-house Design / R.&D departments?	
22 #	Details of pending legal issues on contractual aspects with customers, if any.	
23 #	Please furnish details of Labour problems in the last three years, if any?	

B. FINANCIAL SOUNDNESS OF ORGANIZATION				
Financial Information for last Three Years (Please furnish copy of annual report)				
Sr. No.	Parameters	Year 20	Year 20	Year 20
1#	Please furnish annual turnover of the company. Growth in annual turnover w.r.t. previous years (%)			
2#	Please furnish Profit before tax (PBT) of the company. Growth in PBT w.r.t. previous years (%)			
3#	Please indicate the net worth (Net current assets – Net current liabilities) of the company?			
4#	Whether the vendor has been referred to BIFR / NCLT / any other similar Govt. agency.			
5#	Whether the supplier is a potentially sick company.			
6	Please mention current order book position, as on date in terms of Value and time			

C. QUALITY SYSTEM		
Sr. No.	DESCRIPTION	Sub-vendor response (along with supporting document)
1*	Are you an ISO 9001 company? If yes, please furnish the certificate and what is your quality policy?	
2*	Is the company an ISO 14000 approved?	
3#	Is the company an OHSAS approved?	
4*	Have your company won any Quality award like Rajeev Gandhi National Quality Award, DMC Ramkrishna Bajaj National Quality Award, Golden Peacock National Quality Award etc? If yes provide documentary evidence.	
5*	Have you received appreciation letter from your customer. Please provide evidence.	
6	To whom your Q.C./Q.A. Chief reports to ? (Please furnish your organization structure)	
7*	If you have a written quality control manual/procedure, then please furnish the same.	

	SJVN	FORM NO.: F-060-01 PAGE: 10 of 14 ISSUE: 2.0 REV. 01 DATE: 30/06/2016
	FORM	

7 (i)*	Incoming Material Control System (Furnish a copy of system and organization)	
7 (ii)*	Process Control: Are written procedure defining stage wise operations and functions on shop floor established and followed? (Furnish copy of work instruction and record of process control parameter)	
7 (iii)*	Manufacturing/Testing Procedure Qualification & Personnel Qualification (Procedure qualification specification & Record of personnel qualification (PQR) to be submitted).	
7 (IV)*	Are written Quality Control Instruction sheets prepared & properly used? (Please furnish evidence)	
7 (V)#	Are records generated during inspection maintained & available for review? (Please furnish evidence)	
7 (VI)*	Are quality control checks / procedure adequate to maintain desired quality level right from the incoming stage to final stage? Please furnish copy of such control checks / procedure.	
8.# Documentation Control		
8 (i)	Does a system for clear and precise stipulation of responsibilities for documentation issue & change control exists?	
8 (ii)	Are changes made in writing?	
9* Control of Inspection, measuring and testing equipment		
9 (i)	Are necessary gauges, testing and measuring equipment's, available and used?	
9 (ii)	Are testing and measuring equipment properly maintained?	
9 (iii)	Is recorded control on calibration of equipment available?	
10*	System of Identification & Traceability of materials, tools, jigs, fixtures & processed components, etc. (Copy of procedure to be submitted).	
11*	System of Storage / Preservation / Painting and Packing (copy of Procedure to be submitted)	
12*	Do you have written procedure for disposing off the non-conformities? If yes, please furnish the copy of the same also furnish three copies of NCR & CAPA.	
13*	Safety measures (Submit copy of safety system & record of accidents for last two years)	
14#	What type of Sampling Inspection Plan is used in your factory/company? Please furnish details.	
15	How good are you in keeping your dispatch commitments? Please give details of last ten deliveries stating details as below (Provide documentary evidence) Within delivery period:	

	SJVN	FORM NO.: F-060-01 PAGE: 11 of 14 ISSUE: 2.0
	FORM	REV. 01 DATE: 30/06/2016

	Delayed but accepted by user: Delayed but accepted with penalty:	
16 [#]	Have you ever been de-listed or put in under temporary suspension by any customer / contractor.	
D. AFTER SALES SERVICE		
SR. NO.	DESCRIPTION	Sub-vendor response (along with supporting document)
1 [#]	For overcoming product deficiencies what are the analytical methods used at Customer's premises?	
2 [#]	What is the strength of your "after-sales service" team?	
3 [#]	What is the response time after receiving complaints from the customers? Provide evidence.	
4 [#]	Customer complaints handling system (Submit list of customer complaints & status for the last three years) Please furnish complete list of complaints attended to during last one year.	
5 [#]	How do you keep your "after-sales service" team updated?	
6 [#]	Provide certificate from 02 customers (end user) for satisfactory after sales services.	

Declaration by Director/ Partner/ Proprietor

I declare that the information furnished above and attached documents are correct to the best of my knowledge, I undertake to inform you at the earliest any change(s) in the details mentioned above.

Signature and Date

Name & Designation

	SJVN	FORM NO.: F-060-01 PAGE: 12 of 14 ISSUE: 2.0
	FORM	REV. 01 DATE: 30/06/2016

TO BE FILLED BY MAIN CONTRACTOR FOR SUB-VENDOR (MC)

Sr. No.	Parameters	Supplier response (along with supporting document)
1	Name and address of sub-vendor:	
2 (a)	Type of equipment / item / process / service for which approval is sought:	
2 (b)	Details of equipment / item / process / service for which approval is sought (i.e. Rating, capacity, type, size, weight, etc.):	
3	Experience of main contractor with sub-vendor:	
(a) [#]	Since how many years sub-vendor is registered with you for proposed type of equipment / item / process / services (furnish documentary evidence):	
4#	Whether sub-vendor is meeting the qualification criteria indicated in the technical specification (furnish documentary evidence).	
5 [#]	Sub-vendor rating as per contractor's internal procedure in the scale 0-10 or 0-100% (furnish documentary evidence).	
6#	Any dispute of main contractor with vendor during execution of last 05 contracts.	
7#	Have you ever de-listed or put in temporary suspension the proposed sub-vendor? If yes, please provide the reason for same.	
8	Please indicate the reason for re-approving / re-listing the sub-vendor.	

I declare that the information furnished by Sub-vendor has been verified and found in order / minor changes which have been marked and initialed on this form itself / observed the following discrepancies.

(Signature & Designation)



ARUN-III HEP

	SJVN	FORM NO.: F-060-01 PAGE: 13 of 14 ISSUE: 2.0 REV. 01 DATE: 30/06/2016
	FORM	

**GUIDELINES TO SUPPLIERS FOR FILLING-UP VENDOR/SUPPLIER
REGISTRATION FORM**

1. All columns are to be filled up properly in the space provided for. Wherever it is not applicable / not available, please mention "Not Applicable" / "Not Available". All pages of the form are to be signed along with seal by the authorized signatory.
2. A separate sheet may be attached if the space provided is insufficient or additional information is to be given, Please put proper identification tag on the separately attached sheet.
3. Any information / clarification required by SAPDC/ Consultant during evaluation must be given expeditiously.
4. Please ensure that all required enclosures are attached with the filled up Vendor Registration Form.
5. Marks shall be awarded on the basis of documentary evidences submitted by Vendor / sub-vendor wherever called in vendor / sub-vendor assessment form.
6. Incomplete or incorrect forms will be rejected.
7. Please fill up the check list given below and send along with the vendor registration forms to SAPDC/Consultant.
8. In case any information found incorrect / false, the vendor shall be rejected / de-listed at any stage.
9. Information with # marks is score able.
10. Accepting or rejecting a vendor is sole discretion of SAPDC.
11. Product catalogue / manual for the proposed item / equipment / process / service, if available, shall be submitted alongwith other documents.

	SJVN	FORM NO.: F-060-01 PAGE: 14 of 14 ISSUE: 2.0 REV. 01 DATE: 30/06/2016
	FORM	

Furnish following information/Documents:-

Sr. No.	Description	Yes / No	Page No / Annexure
1	Latest audited annual account.		
2	Balance Sheet.		
3	Valid Income Tax Clearance Certificate.		
4	Details of Pending Arbitration cases.		
5	Details of pending disputes with Statutory Authorities.		
6	Organization chart		
7	Copy of Performance certificate (minimum 03)		
8	Copy of minimum three (03) completion certificates of similar work / service.		
9	Letter of approval from ASME / NTPC/ EIL / Railway / Lloyds / Power Grid etc. if any.		
10	ISO: 9001 certificate		
11	Quality Manual		
12	ISO: 14000 certificate		
13	OHSAS, ISO 18000 certificate		
14	Experience list		
15	Type test report & approval certificate		
16	Product Approval certificate from national / international agency.		
17	Quality award certificate		
18	Process and Personnel qualification certificates		
19	Copy of registration / enlistment with reputed / large organizations		
20	Detail of existing clients and details such as address, contact number and mail address.		
21	List of works / projects of similar nature executed with documentary evidences of works executed in last 02 years.		
22	Other documents mentioned elsewhere in vendor / sub-vendor assessment form.		

(Signature & Designation)

	<h1 style="margin:0;">SJVN</h1>	FORM NO.: F-080-02 PAGE: 1 of 1 ISSUE: 2.0 REV. 01 DATE: 30/06/2018
	<h2 style="margin:0;">FORM</h2>	

	PROJECT NAME (MW)			MANUFACTURING / FIELD QUALITY ASSURANCE PLAN				CONTRACTOR NAME, ADDRESS & LOGO				
	ITEM DESCRIPTION			SUB-ITEM	QAP NO.	REV. NO	ISSUE DATE	SUB-CONTRACTOR NAME, ADDRESS & LOGO				
SR. NO.	COMPONENT & OPERATION	CHARACTERISTICS	CLASS	TYPE OF CHECK	QUANTUM OF CHECK		REFERENCE DOCUMENT	ACCEPTANCE NORMS	FORMAT OF RECORD	AGENCY	REMARKS	
					M/C	S			M	C	S	
1	2	3	4	5	6	7	8	9	10	11		
LEGENDS												
M	MANUFACTURER	C	CONTRACTOR				S	SAPDC LTD.				
P	PERFORM	V	VERIFICATION OF RECORDS				W	WITNESS / CHP				
IR	INSPECTION REPORT	DRG	DRAWING				CHP	CUSTOMER HOLD POINT				
MA	MAJOR	MN	MINOR				CR	CRITICAL				
ME	MEASUREMENT	NDT	NON DESTRUCTIVE TESTING				HT	HEAT TREATMENT				
TR1	CERTIFICATE OF COMPLIANCE TO TS/STANDARD REQUIREMENT WITHOUT ANY CHECK LIST OF TESTS CARRIED OUT.	TR2	CERTIFICATE OF COMPLIANCE TO TS/STANDARD REQUIREMENT WITH CHECK LIST OF TESTS CARRIED OUT.				TR3	TEST REPORT/TEST CERTIFICATE WITH TEST RESULTS BASED ON SPECIFIC INSPECTION & TESTING AT MANUFACTURER FACILITY/NABL APPROVED LAB.				
NOTE: QAP SHALL BE READ IN CONJUNCTION WITH QUALITY ASSURANCE REQUIREMENT GIVEN AS PART OF TECHNICAL SPECIFICATION.												
MANUFACTURER / SUB-CONTRACTOR:			CONTRACTOR:		FOR SAPDC USE:		REFERENCE DOC NO. OF SJVN:					
PREPARED BY:		REVIEWED BY		REVIEWED & RECOMMENDED BY		REVIEWED BY		RECOMMENDED BY		APPROVED BY		
NAME, DESIGNATION & SIGNATURE		NAME, DESIGNATION & SIGNATURE		NAME, DESIGNATION & SIGNATURE		NAME & SIGNATURE		NAME & SIGNATURE		SIGNATURE & SEAL		

Prepared By:	Reviewed By:	Approved By:
		Process Owner



ARUN-III HEP

	SJVN	FORM NO.: F-060-04 PAGE: 1 of 5 ISSUE: 2.0 REV. 01 DATE: 28/06/2016
	FORM	

	SJVN	FORM NO.: F-060-04 PAGE: 2 of 5 ISSUE: 2.0 REV. 01 DATE: 28/06/2016
	FORM	

NON-CONFORMITY REPORT FOR MANUFACTURING, TRANSPORTATION, STORAGE & ERECTION STAGES		FOR SAPDC USE ONLY	
		NC NO. _____	
		Date: _____	
		PAGE 1 of 5	
PART-A (Proposal of Disposition of Non Conformity)			
Please read instructions carefully before filling up the form and attach separate sheet wherever required.			
Contract No.	CATEGORY OF NON CONFORMITY		
Package Unit No.	(Please refer instruction no.1&Tick appropriate)		
Supplier/ Contractor	MAJOR	<input type="checkbox"/>	
Sub-Vendor	MINOR	<input type="checkbox"/>	
Place of Manufacture			
DETAILS			
ITEM DESCRIPTION: _____	IDENTIFICATION NO. _____		
RANGE/SIZE/TYPE: _____	QUALITY PLAN NO.: _____		
	& CLAUSE NO. _____		
STAGE OF NON-CONFORMITY <input type="checkbox"/>			
DESIGN (A) /RAW MATERIAL (B) /ASSEMBLY (C) / IN PROCESS (D)-Specify _____ /			
TESTING (E)/ STORAGE (F) /HANDLING & TRANSPORTATION (G) /ERECTION & COMMISSIONING (H) /ANY OTHER (I) (SPECIFY) _____			
NON CONFORMITY-DESCRIPTION WITH CAUSE (Attach Relevant Drawings/ Details):			
PROPOSED DISPOSITION WITH JUSTIFICATION(For Correction): (Note: Attach Details including design calculation)			Disposition Code <input type="checkbox"/>

NON-CONFORMITY REPORT FOR MANUFACTURING, TRANSPORTATION, STORAGE & ERECTION STAGES		FOR SAPDC USE ONLY	
		NC NO. _____	
		Date: _____	
		PAGE 2 of 5	
STEPS TO PREVENT RECCURANCE (For Corrective Action):			
ENCLOSURE SUBMITTED BY CONTRACTOR:-			
<input type="checkbox"/> DRAWINGS/ DETAILS <input type="checkbox"/> INSPECTION REPORT <input type="checkbox"/> ROOT CAUSE ANALYSIS			
<input type="checkbox"/> PROCEDURE OF DISPOSAL OF NCR <input type="checkbox"/> ANY OTHER (Please specify) _____			
DATE	NAME & DESIGN	SIG.OF CONTRACTOR	SEAL
FINAL DISPOSITIONING BY SAPDC			Disposition Code
INCHARGE of RIO or FQA (In case of Minor)			<input type="checkbox"/>
SAPDC (In case of Major)			
DATE	NAME & DESIG.	SIGNATURE	

	SJVN	FORM NO.: F-060-04 PAGE: 3 of 5 ISSUE: 2.0
	FORM	REV. 01 DATE: 28/06/2016

	SJVN	FORM NO.: F-060-04 PAGE: 4 of 5 ISSUE: 2.0
	FORM	REV. 01 DATE: 28/06/2016

NON-CONFORMITY REPORT FOR MANUFACTURING, TRANSPORTATION, STORAGE & ERECTION STAGES	FOR SAPDC USE ONLY
	NC NO.
	Date:
	PAGE 3 of 5
FOR SAPDC INTERNAL USE ONLY	
RECOMMENDATION of INCHARGE of RIO or FQA (In case of Major)/ CONCERNED SAPDC 's INSPECTION/ SITE ENGINEER (In case of Minor)	Disposition Code <input type="checkbox"/>
DATE _____ NAME & DESIG. _____	SIGNATURE _____
RECOMMENDATION OF SAPDC CONCERNED ENGINEER	Disposition Code <input type="checkbox"/>
DATE _____ NAME & DESIG. _____	SIGNATURE _____
DATE _____ NAME & DESIG. _____	SIGNATURE _____
RECOMMENDATION OF SAPDC (FOR MAJOR CATEGORY) (Comments of Engineering / Others deptt as applicable to be considered)	
DATE _____ NAME & DESIG. _____	SIGNATURE _____

NON-CONFORMITY REPORT FOR MANUFACTURING, TRANSPORTATION, STORAGE & ERECTION STAGES	FOR SAPDC USE ONLY
	NC NO.
	Date:
	PAGE 4 of 5
PART B (Verification of Corrections of Non- Conformity) <i>(Filled after Completion of corrections of Non-Conformity)</i>	
ACTION TAKEN BY SUPPLIER/ CONTRACTOR (Attach Report of verification)	
DATE _____ NAME & DESIGN _____	SIG.OF SUPPLIER/ CONTRACTOR _____ SEAL _____
VERIFICATION BY SAPDC'S SITE ENGINEER/ INSPECTION ENGINEER	
DATE _____ NAME & DESIG. _____	SIGNATURE _____
DATE _____ NAME & DESIG. _____	SIGNATURE _____
COMMENTS OF SAPDC ENGINEER	
DATE _____ NAME & DESIG. _____	SIGNATURE _____
DATE _____ NAME & DESIG. _____	SIGNATURE _____
DATE _____ NAME & DESIG. _____	SIGNATURE _____

ARUN-III HEP

	SJVN	FORM NO.: F-060-04
	FORM	PAGE: 5 of 5 ISSUE: 2.0 REV. 01 DATE: 28/06/2016

NON-CONFORMITY REPORT FOR MANUFACTURING, TRANSPORTATION, STORAGE & ERECTION STAGES	FOR SAPDC USE ONLY
	NC NO.
	Date:
	PAGE 5 of 5

INSTRUCTIONS
<ol style="list-style-type: none"> 'MAJOR' NONCONFORMITY IS DEFINED AS DEPARTURE FROM SPECIFICATION WHICH AFFECTS PERFORMANCE RELIABILITY. SAFETY INTERCHANGEABILITY. ERECTION, COMMISSIONING OR WORKING LIFE ALL OTHER NON-CONFORMITIES SHALL BE TREATED AS CATEGORY 'MINOR'. ACCEPTANCE OF DISPOSITIONED NON-CONFORMANCE IS WITHOUT PREJUDICE TO SAPDC RIGHT TO CLAIM COMMERCIAL REBATE AND DOES NOT ABSOLVE CONTRACTUAL OBLIGATIONS. OBTAINING APPROVAL OF STATUTORY AUTHORITY IF ANY W.R.T. ABOVE NON CONFORMANCE IS THE RESPONSIBILITY OF SUPPLIER/ CONTRACTOR. DISPOSITIONING OF THIS NON-CONFORMANCE IS FOR THIS SPECIFIC CASE ONLY AND NOT TO BE REGARDED AS PRECEDENCE. DISPOSITION CODE THE NON-CONFORMANCE SHALL BE DISPOSITIONED AS UNDER BY SAPDC AND SUPPLIER. (GIVE CODE AT APPROPRIATE BOXES):- (01) NC-REJECTED (02) NC- CONDITIONALLY ACCEPTED (SPECIFY CONDITION) (03) NC-ACCEPTED AS-IT-IS (04) NC-ACCEPTED WITH REPAIR. NC NUMBER - THIS NO. SHALL BE ALLOTTED BY SAPDC AND SHALL HAVE SAPDC PROJECT NAME, PACKAGE, FOLLOWED BY RUNNING SERIAL NO. & ENTER TO NC REPORT BY RIO/ FQA/ CQAL

RESPONSIBILITIES OF CONTRACTOR
<ol style="list-style-type: none"> ASCERTAIN EXACT NATURE OF NON-CONFORMANCE AND ALONGWITH SUPPORTING DRAWING OF ITEMS/ EQUIPMENT ETC WITH WHICH NON-CONFORMANCE EXISTS. IDENTIFY THE CAUSE OF NON CONFORMITY. DECIDE ON CODE OF DISPOSING. FINALISE THE CAUSE OF NON-CONFORMITY AND PROPOSE CORRECTIVE ACTION. ENSURE AND CERTIFY THAT THE PRODUCT QUALITY PERFORMANCE, RELIABILITY AND WORKING LIFE IS NOT AFFECTED FOR MINOR NON-CONFORMITIES AND QUANTIFY THE EXTENT TO WHICH IT IS AFFECTED IN THE CASE OF CATEGORY 'MAJOR' NON-CONFORMITIES. IMPLEMENT AGREED CORRECTIVE ACTION IN A TIME BOUND PROGRAMME AND PROVIDE FEEDBACK AS PER PART-B OF THE FORMAT

RESPONSIBILITIES OF RIO/ FQA
<ol style="list-style-type: none"> IDENTIFY THE PRODUCT APPROPRIATELY. ANALYSE THE CAUSE OF NON-CONFORMITY AND PROPOSE RECOMMENDATION

ARUN-III HEP

	SJVN	FORM NO.: F-060-06
	FORM	PAGE: 1 of 1 ISSUE: 2.0 REV. 00 DATE: 30/06/2016

INSPECTION CALL REQUEST

Inspection Call No.		Date:				
Project:			Contract No. :			
Contractor/Supplier's Name & Address:			Sub-vendor/Sub-Supplier's Name & Address:			
Contact Person:			Contact Person:			
Telephone/Mobile No.:			Telephone/Mobile No.:			
Fax No.			Fax No.			
email ID:			email ID:			
Details of Equipment with Unit No.:						
Sr. No.	Equipment/Item Description and Sr. No.	Unit No.	BBU Ref.	QAP No. & Rev. No.	Relevant QAP Clause No.	Approved Drawing No. & Rev. No.
Status of Type Tests		Approved / Not Approved / Not Applicable		Place of Inspection:		
Proposed date of Inspection:				Anticipated Working Days Required		
Status of internal inspection by Vendor/sub-vendor			Completed	In-progress	Yet to be done	
			<input type="checkbox"/>	<input type="checkbox"/>	<input type="checkbox"/>	
Tentative date of completion of internal inspection in case inspection is in-progress/yet to be done:						
Note: Readiness status is to be submitted separately after completion of internal inspection by Manufacturer.						

Date:
Place:

Signature
Name
Designation
Department
Company

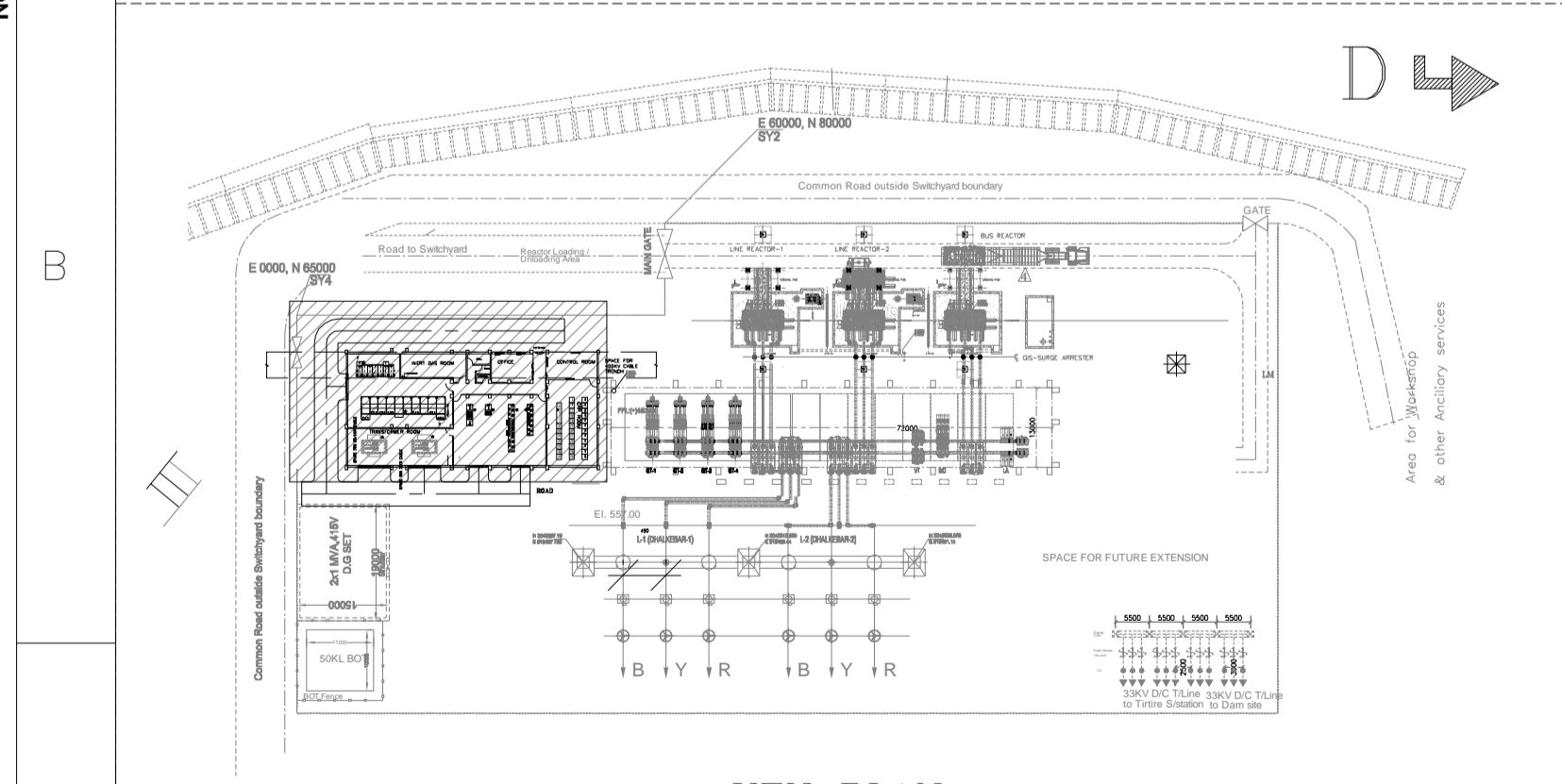
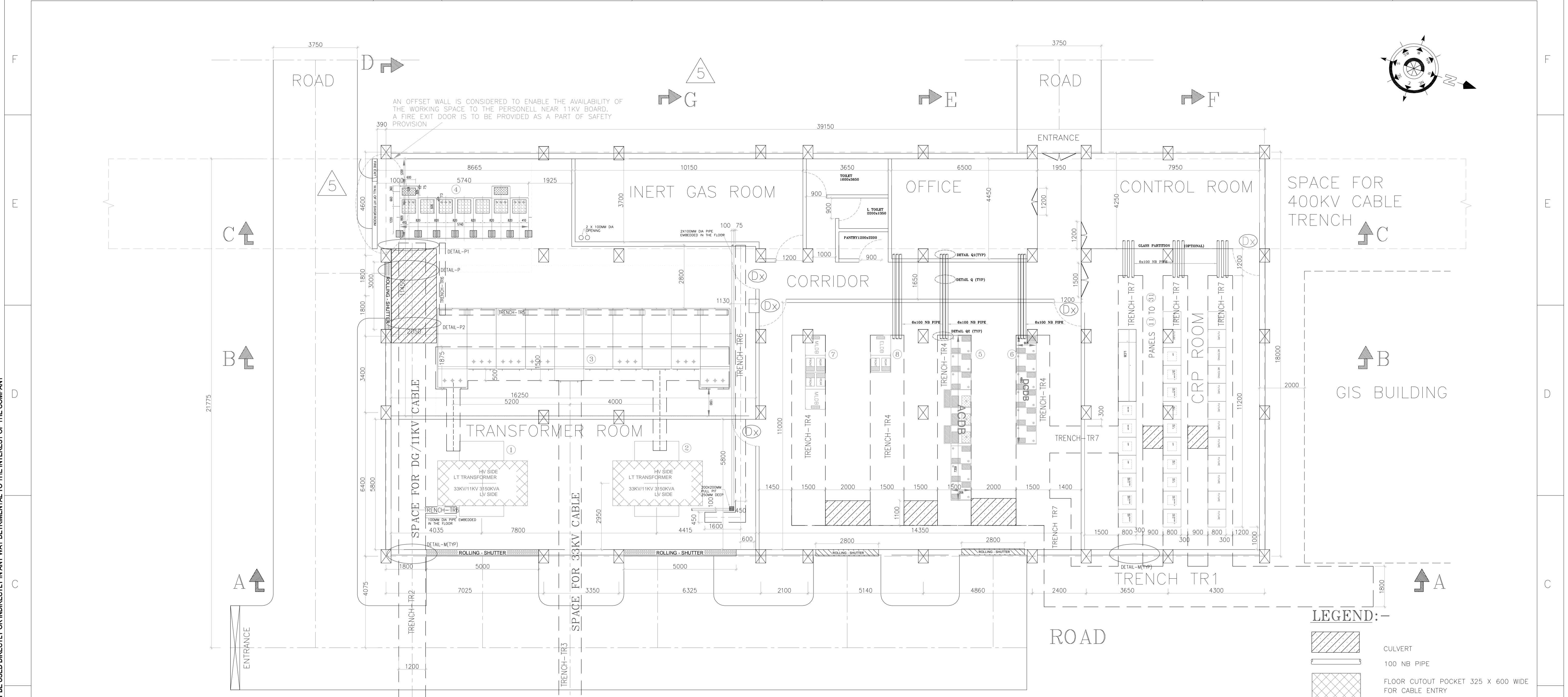

एनर्जी डेवलपमेंट अथॉरिटी नेपाल प्रा. लि.
SJVN Arun-3 Power Development Company Pvt. Ltd.
Category: **Approval**

Approved by: [Signature]
Reviewed: [Signature]
Recommended: [Signature]
Approved: [Signature]

- LEGEND:-**
- CULVERT
 - 100 NB PIPE
 - FLOOR CUTOUT POCKET 325 X 600 WIDE FOR CABLE ENTRY
 - FLOOR CUTOUT POCKET 600 X 600 WIDE FOR CABLE ENTRY
 - FLOOR CUTOUT POCKET 300 X 300 WIDE FOR CABLE ENTRY
 - DOOR FOR STAFF MOVEMENT ONLY SIZE AS PER CUSTOMER STANDARDS
 - COLUMN OF THE BUILDING

REV.	DATE	ALTERED	REV.	DATE	ALTERED	REV.	DATE	ALTERED	REV.	DATE	ALTERED						
06	11.11.2021	CHD/APPD	05	03.11.2021	CHD/APPD	04	08.09.2021	CHD/APPD	03	30.06.2021	CHD/APPD						
ZONE	THE DOCUMENT HAS BEEN REVISED BASED ON THE COMMENTS RECEIVED FROM THE CUSTOMER DATED 9 NOV .2021		ZONE	THE DOCUMENT HAS BEEN REVISED BASED ON THE COMMENTS RECEIVED FROM THE CUSTOMER DATED 21.09.2021 AND VC HELD BETWEEN BHEL AND SJVN DATED : 26.10.2021		ZONE	THE DOCUMENT HAS BEEN REVISED BASED ON THE COMMENTS RECEIVED FROM THE CUSTOMER VIDE MEETING WITH SJVN AND TELECONFERENCE IN JUNE 2021 AND AUGUST 20.08.2021		ZONE	THE DOCUMENT HAS BEEN REVISED BASED ON THE COMMENTS RECEIVED FROM THE CUSTOMER VIDE MEETING WITH SJVN AND TELECONFERENCE IN JUNE 2021		ZONE	THE DOCUMENT HAS BEEN REVISED BASED ON THE COMMENTS RECEIVED FROM THE CUSTOMER VIDE MOM DATED 19.03.2021 AND MEETING WITH SJVN		ZONE	THE DOCUMENT HAS BEEN REVISED BASED ON THE COMMENTS RECEIVED FROM THE CUSTOMER VIDE MOM DATED 23.02.2021	
<p>PROJECT: ARUN-3 HYDRO ELECTRIC PROJECT (NEPAL) (4 x 225 MW)</p> <p>CUSTOMER: SJVN ARUN-3 POWER DEVELOPMENT COMPANY PVT. LTD. (SAPDC LTD.)</p> <p>CONSULTANT: SJVN LTD. (A JOINT VENTURE OF GOVT OF INDIA AND GOVT OF HP)</p> <p>BHARAT HEAVY ELECTRICALS LTD. TRANSMISSION BUSINESS GROUP NOIDA</p>																	
DEPT. TBG CODE			SCALE NTS			CARD CODE			DRG.NO. TB-3-405-316-021			REV. 6					
TITLE: CONCEPTUAL LAYOUT of CRP ROOM IN SWITCHGEAR BUILDING OF 400kV SWITCHYARD OF ARUN 3 HEP												SHT. No 1		NO. OF SHT. 05			

THE INFORMATION ON THIS DOCUMENT IS THE PROPERTY OF BHARAT HEAVY ELECTRICALS LIMITED. IT MUST NOT BE USED DIRECTLY OR INDIRECTLY IN ANY WAY DETRIMENTAL TO THE INTEREST OF THE COMPANY

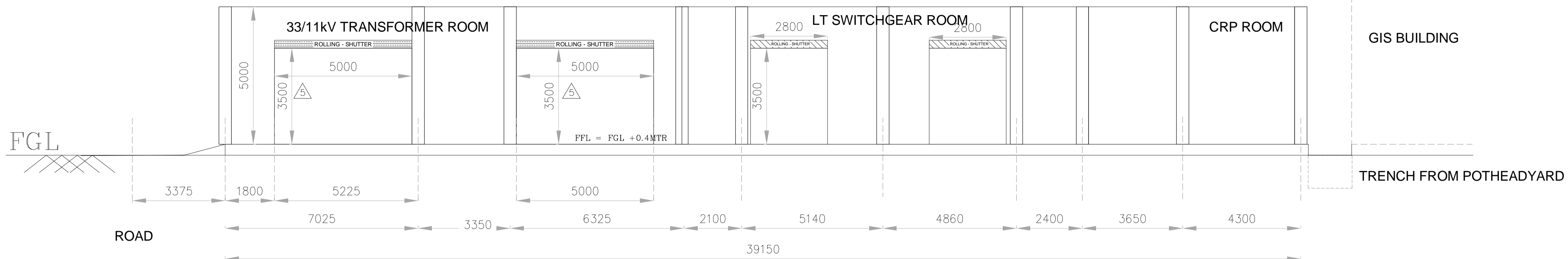

VIEW A-A

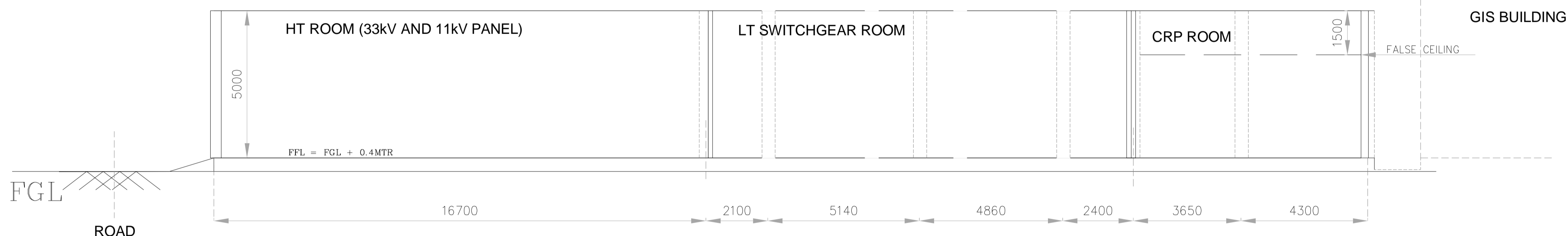

VIEW B-B

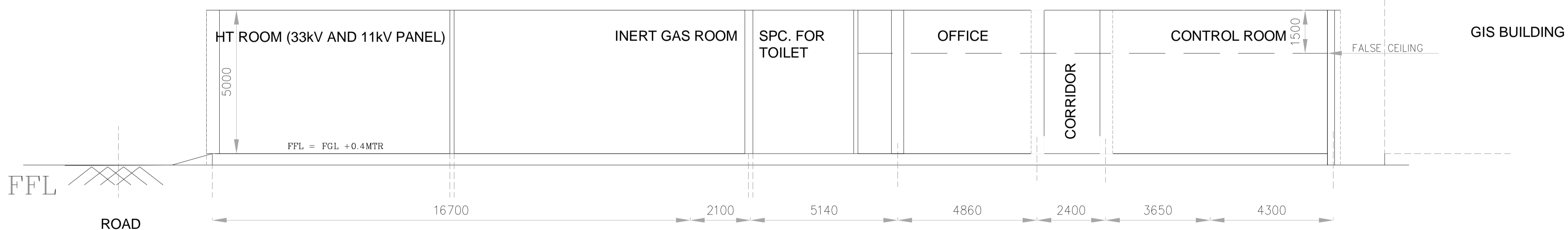

VIEW C-C

NOTE:
 CLEAR HEIGHT OF THE OPENING IN THE DOORS TO BE CONSIDERED AS 3250 MM
 ROLLING SHUTTER /STEEL DOOR TO BE PROVIDED IN 33/11KV TRANSFORMER ROOM

REV.	DATE	ALTERED	REV.	DATE	ALTERED
06	11.11.2021	CHD/APPD	05	03.11.2021	CHD/APPD
ZONE	THE DOCUMENT HAS BEEN REVISED BASED ON THE COMMENTS RECEIVED FROM THE CUSTOMER DATED 9 NOV .2021		ZONE	THE DOCUMENT HAS BEEN REVISED BASED ON THE COMMENTS RECEIVED FROM THE CUSTOMER DATED 21.09.2021 AND VC HELD BETWEEN BHEL AND SJVN DATED : 26.10.2021	
04	08.09.2021	CHD/APPD	03	30.06.2021	CHD/APPD
ZONE	THE DOCUMENT HAS BEEN REVISED BASED ON THE COMMENTS RECEIVED FROM THE CUSTOMER VIDE MEETING WITH SJVN AND TELECONFERENCE IN JUNE 2021 AND AUGUST 20.08.2021		ZONE	THE DOCUMENT HAS BEEN REVISED BASED ON THE COMMENTS RECEIVED FROM THE CUSTOMER VIDE MEETING WITH SJVN AND TELECONFERENCE IN JUNE 2021	
02	07.06.2021	CHD/APPD	01	05.03.2021	CHD/APPD
ZONE	THE DOCUMENT HAS BEEN REVISED BASED ON THE COMMENTS RECEIVED FROM THE CUSTOMER VIDE MOM DATED 19.03.2021 AND MEETING WITH SJVN		ZONE	THE DOCUMENT HAS BEEN REVISED BASED ON THE COMMENTS RECEIVED FROM THE CUSTOMER VIDE MOM DATED 23.02.2021	

PROJECT: ARUN-3 HYDRO ELECTRIC PROJECT (NEPAL)
 (4 x 225 MW)

CUSTOMER: SJVN ARUN-3 POWER DEVELOPMENT COMPANY PVT. LTD. (SAPDC LTD.)

CONSULTANT: SJVN LTD.
 (A JOINT VENTURE OF GOVT OF INDIA AND GOVT OF HP)

NAME	SIGN.	DATE
DRN. PK		30/10/2018
CHD. Vyom./JK		30/10/2018
APPD. SKS		30/10/2018

DEPT. TBG
 CODE

TITLE
 CONCEPTUAL LAYOUT of CRP ROOM IN SWITCHGEAR BUILDING OF 400kV SWITCHYARD OF ARUN 3 HEP

DRG.NO. TB-3-405-316-021
 SHT. No 2 NO. OF SHT. 05
 REV. 6

THE INFORMATION ON THIS DOCUMENT IS THE PROPERTY OF BHARAT HEAVY ELECTRICALS LIMITED. IT MUST NOT BE USED DIRECTLY OR INDIRECTLY IN ANY WAY DETRIMENTAL TO THE INTEREST OF THE COMPANY

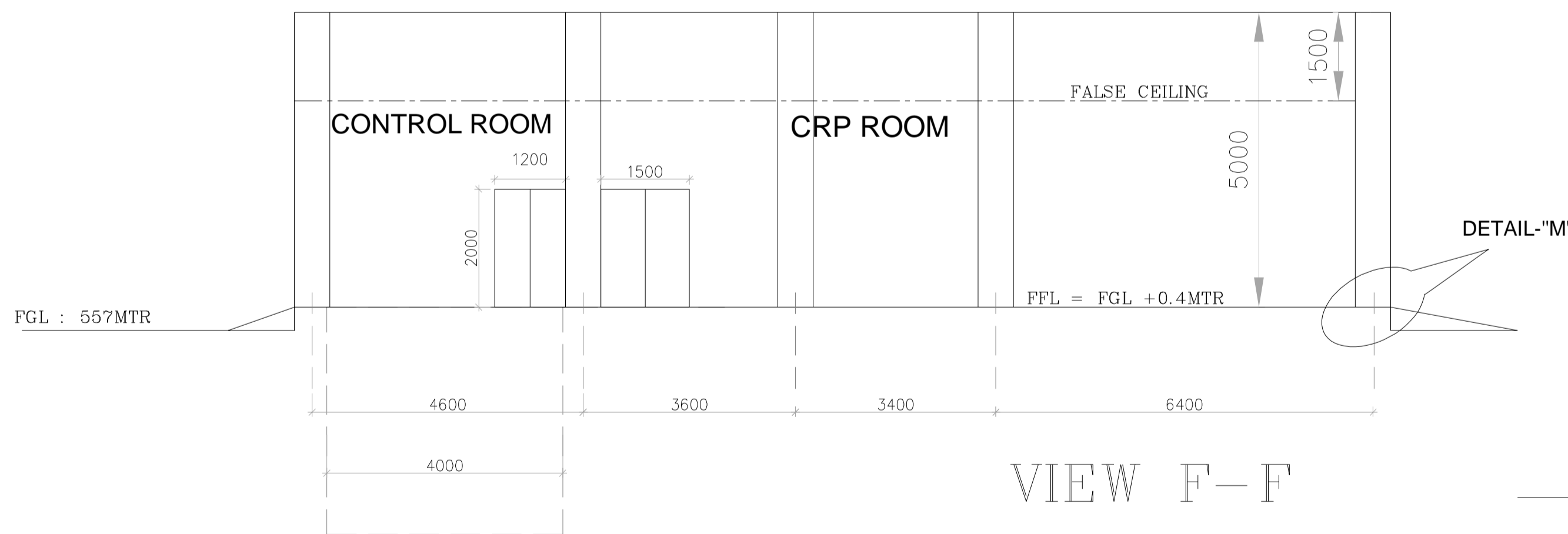
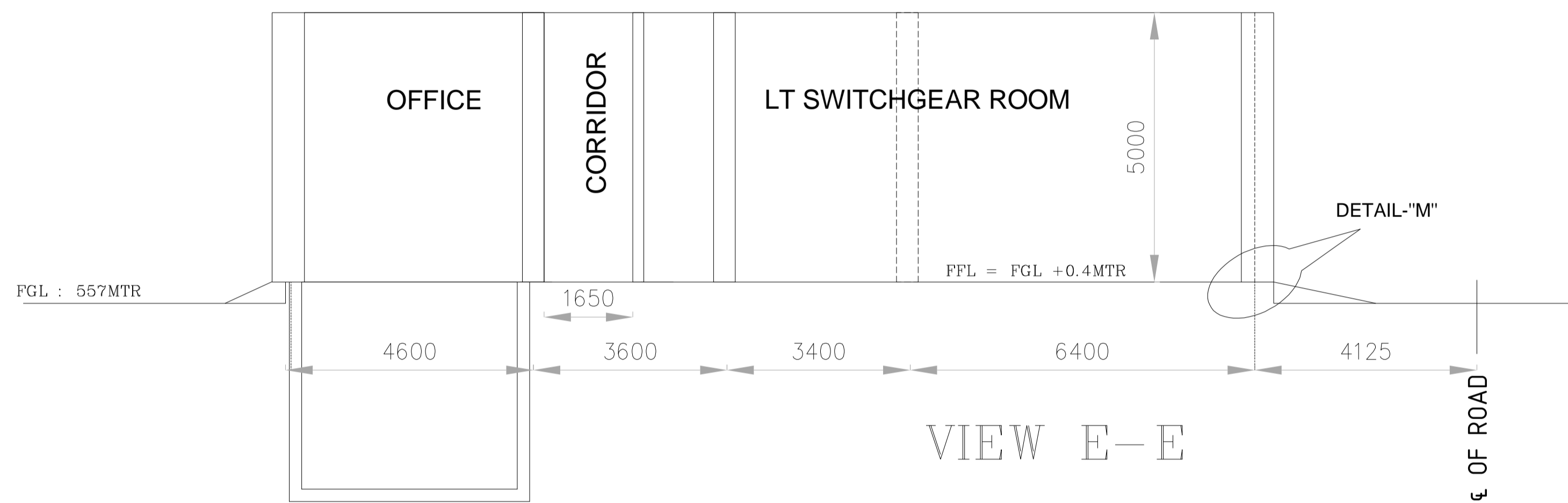
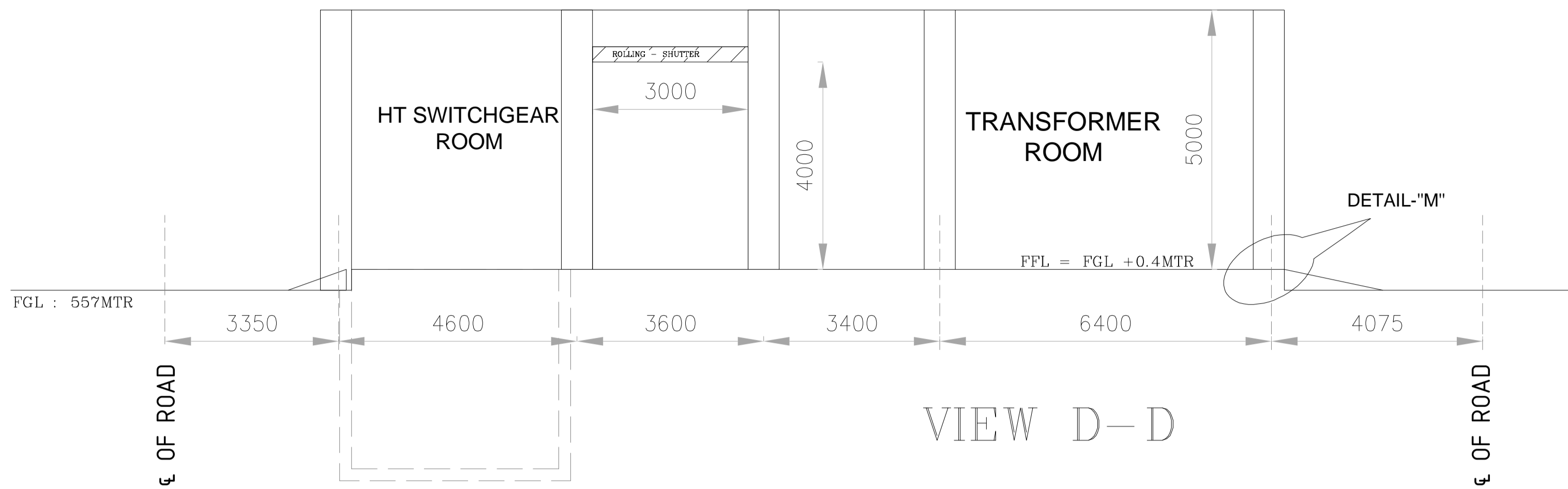

Panel References :

A Transformer Room		
1	Transformer 33kV/11kV -A	1 Nos
2	Transformer 33kV/11kV -B	1 Nos
B HT Panel Room		
3	33kV Panels - 13.0m x 3.50m x 2.50m - dwg no : 3 521 00 5 6540	1 Nos
4	11kV Panels - 5.74m x 2.35m x 2.70m - dwg no : 3 521 00 5 6517	1 Nos
C LT Panel Room		
5	ACDB - 7.36m x 0.9m x 2.8m (tentative)	1 Nos
6	DCDB - 5.00m x 0.9m x 2.8m (tentative)	1 Nos
7	MLDB - 3.30m x 0.9m x 2.8m (tentative)	1 Nos
8	ELDB - 1.60m x 0.9m x 2.8m (tentative)	1 Nos
9	AC-PDB - 1.80m x 0.9m x 2.8m (tentative)	1 Nos
10	VENTILLATION-PDB - 1.80m x 0.9m x 2.8m (tentative)	1 Nos
D CRP Room		
11	400kV Side Generator Transformer	1 Nos
12	400kV Line Reactor-1 (Panel A)	1 Nos
13	400kV Line Reactor-1 (Panel B)	1 Nos
14	400kV Line Dhalkebar-1 (Panel A)	1 Nos
15	400kV Line Dhalkebar-1 (Panel B)	1 Nos
16	400kV Side Generator Transformer	1 Nos
17	400kV Line Dhalkebar-2 (Panel A)	1 Nos
18	400kV Line Dhalkebar-2 (Panel B)	1 Nos
19	400kV Line Reactor-2 (Panel A)	1 Nos
20	400kV Line Reactor-2 (Panel B)	1 Nos
21	400kV Bus Coupler -2 (Panel B)	1 Nos
22	400kV Bus Reactor (Panel A)	1 Nos
23	400kV Bus Reactor (Panel B)	1 Nos
24	400kV Side GT	1 Nos
25	400kV Side GT	1 Nos
26	400kV Bus Bar	1 Nos
27	400kV Bus Bar	1 Nos
28	LCB - 3.0m x 0.8m x 2.5m - DWG NO : 3 694 00 00 836 Rev 02	1 Nos
29	PLCC/FOTE (SAPDC/SJVN Supply) - 0.75 m x 0.75 m x 2.2m (tentati	2 Nos
30	METERING PANEL - 0.75 m x 0.75 m x 2.2m	2 Nos
31	FUTURE PANEL - 0.75 m x 0.75 m x 2.2m	10 Nos

NOTES:-

- ALL DIMENSION ARE IN MM UNLESS OTHERWISE NOTED.
- HEIGHT OF ROOMS SHOWN IN SECTION IS CLEAR HEIGHT FROM BEAMS TO FFL.
- ELEVATION SHOWN ABOVE IS FOR INDICATION OF HEIGHTS ONLY.
- CABLE ENTRY FOR ALL PANELS SHALL BE THROUGH BOTTOM.
- SIZE AND NUMBER OF PANELS INDICATED HERE ARE TENTATIVE AND SUBJECT CHANGES.
- TRENCH SECTION SHALL BE PART OF DRAWING OF INDOOR TRENCH LAYOUT.
- EDGE PROTECTION TO BE PROVIDED AT THE EDGE OF FLOOR CUTOUT AND CABLE TRENCH.
- ALL THE PVC PIPE OPENINGS SERVING AS THE CONDUIT SHALL BE SEALED WITH A SEALANT AFTER CABLE LAYING.

DRAWING REFERENCE:-

- 33kV POTHEADYARD SWITCHBOARD - 3 521 00 5 6540
- 11KV POTHEADYARD SWITCHBOARD - 3 521 00 5 6517
- OGA OF LCB OF 400KV SWITCHYARD - 3 694 00 00836 r2
- OGA OF LCB OF 400KV SWITCHYARD - 3 694 00 00836 r2
- OGA OF 400KV SWITCHYARD RELAY PANEL - 25610051715
- OGA OF 33/11kV 3150KVA TRANSFORMER - DWG NO :34730052489

REV. 06	DATE 11.11.2021	ALTERED CHD/APPD	REV. 05	DATE 03.11.2021	ALTERED CHD/APPD
ZONE	THE DOCUMENT HAS BEEN REVISED BASED ON THE COMMENTS RECEIVED FROM THE CUSTOMER DATED 9 NOV .2021		ZONE	THE DOCUMENT HAS BEEN REVISED BASED ON THE COMMENTS RECEIVED FROM THE CUSTOMER DATED 21.09.2021 AND VC HELD BETWEEN BHEL AND SJVN DATED : 26.10.2021	
REV. 04	DATE 08.09.2021	ALTERED CHD/APPD	REV. 03	DATE 30.06.2021	ALTERED CHD/APPD
ZONE	THE DOCUMENT HAS BEEN REVISED BASED ON THE COMMENTS RECEIVED FROM THE CUSTOMER VIDE MEETING WITH SJVN AND TELECONFERENCE IN JUNE 2021 AND AUGUST 20.08.2021		ZONE	THE DOCUMENT HAS BEEN REVISED BASED ON THE COMMENTS RECEIVED FROM THE CUSTOMER VIDE MEETING WITH SJVN AND TELECONFERENCE IN JUNE 2021	
REV. 02	DATE 07.06.2021	ALTERED CHD/APPD	REV. 01	DATE 05.03.2021	ALTERED CHD/APPD
ZONE	THE DOCUMENT HAS BEEN REVISED BASED ON THE COMMENTS RECEIVED FROM THE CUSTOMER VIDE MOM DATED 19.03.2021 AND MEETING WITH SJVN		ZONE	THE DOCUMENT HAS BEEN REVISED BASED ON THE COMMENTS RECEIVED FROM THE CUSTOMER VIDE MOM DATED 23.02.2021	

PROJECT: ARUN-3 HYDRO ELECTRIC PROJECT (NEPAL)
(4 x 225 MW)

CUSTOMER: SJVN ARUN-3 POWER DEVELOPMENT COMPANY PVT. LTD. (SAPDC LTD.)

CONSULTANT: SJVN LTD.
(A JOINT VENTURE OF GOVT OF INDIA AND GOVT OF HP)

NAME	SIGN.	DATE
DRN. PK		30/10/2018
CHD. Vyom/JK		30/10/2018
APPD. SKS		30/10/2018

DEPT. TBG CODE

SCALE NTS

CARD CODE

TITLE: CONCEPTUAL LAYOUT of CRP ROOM IN SWITCHGEAR BUILDING OF 400kV SWITCHYARD OF ARUN 3 HEP

DRG.NO. TB-3-405-316-021

REV. 6

SHT. No 3 NO. OF SHT. 05

REV. 04	DATE 08.09.2021	ALTERED CHD/APPD	REV. 03	DATE 30.06.2021	ALTERED CHD/APPD
ZONE	THE DOCUMENT HAS BEEN REVISED BASED ON THE COMMENTS RECEIVED FROM THE CUSTOMER VIDE MEETING WITH SJVN AND TELECONFERENCE IN JUNE 2021 AND AUGUST 20.08.2021		ZONE	THE DOCUMENT HAS BEEN REVISED BASED ON THE COMMENTS RECEIVED FROM THE CUSTOMER VIDE MEETING WITH SJVN AND TELECONFERENCE IN JUNE 2021	

THE INFORMATION ON THIS DOCUMENT IS THE PROPERTY OF BHARAT HEAVY ELECTRICALS LIMITED. IT MUST NOT BE USED DIRECTLY OR INDIRECTLY IN ANY WAY DETRIMENTAL TO THE INTEREST OF THE COMPANY

A

SIZE-A2

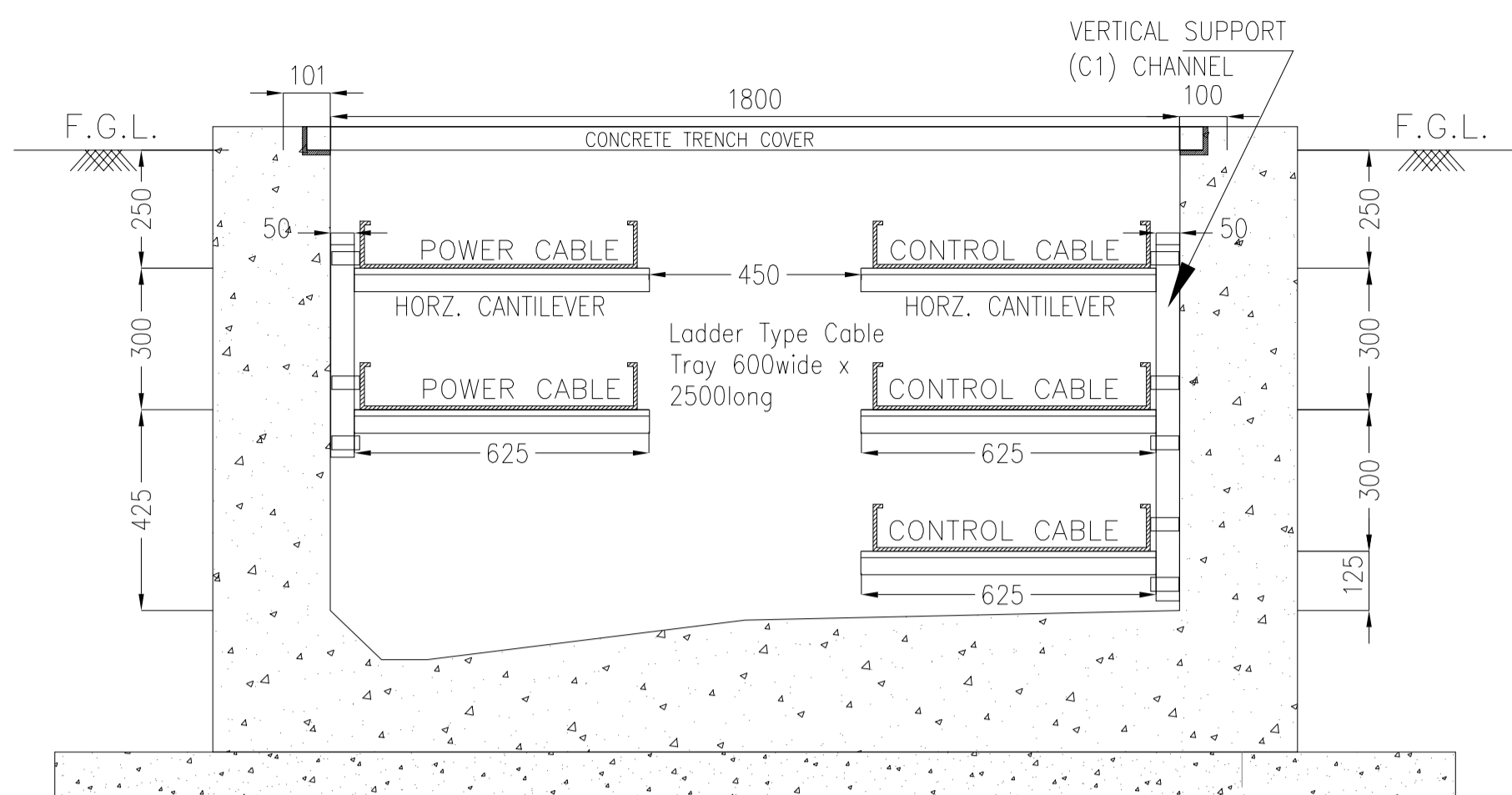

SECTION TR1 (OUTDOOR)

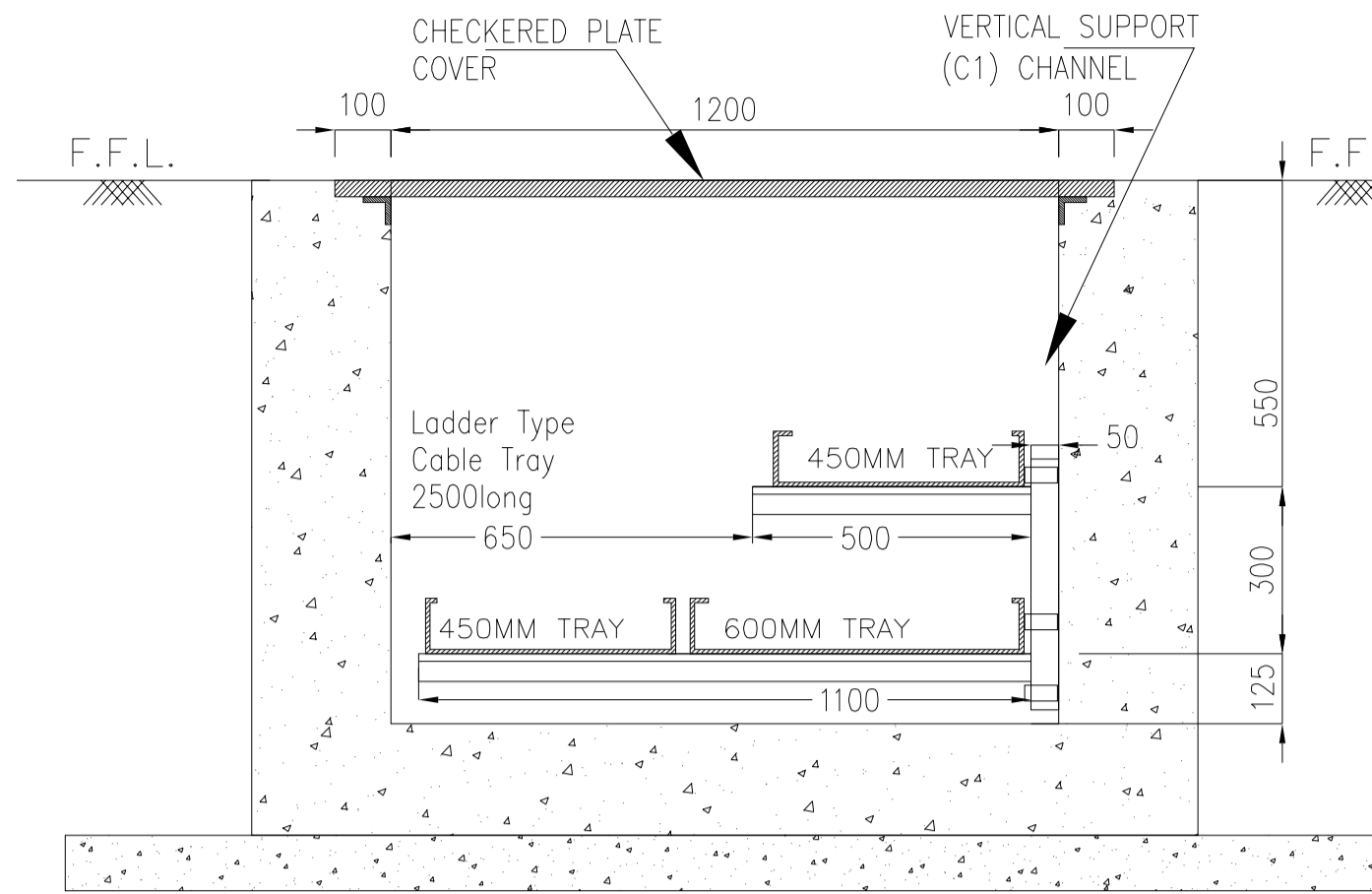

SECTION TR2

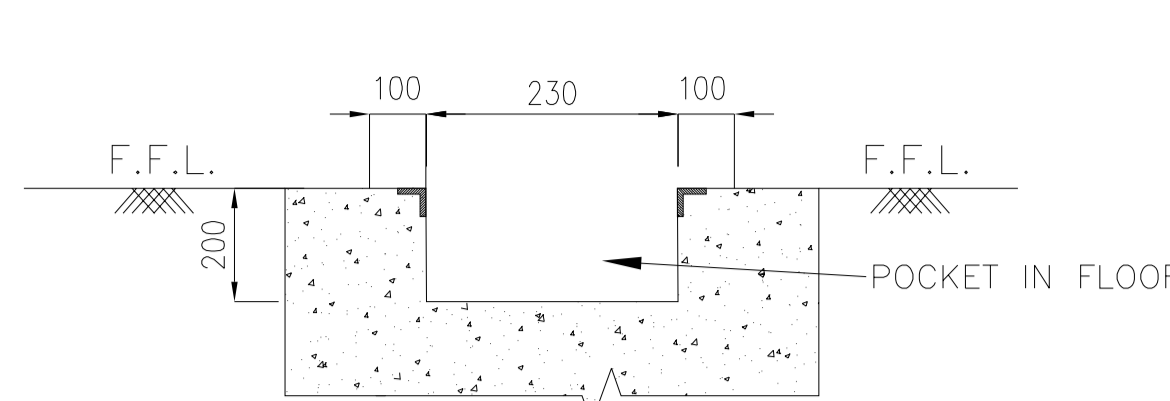

SECTION TR5

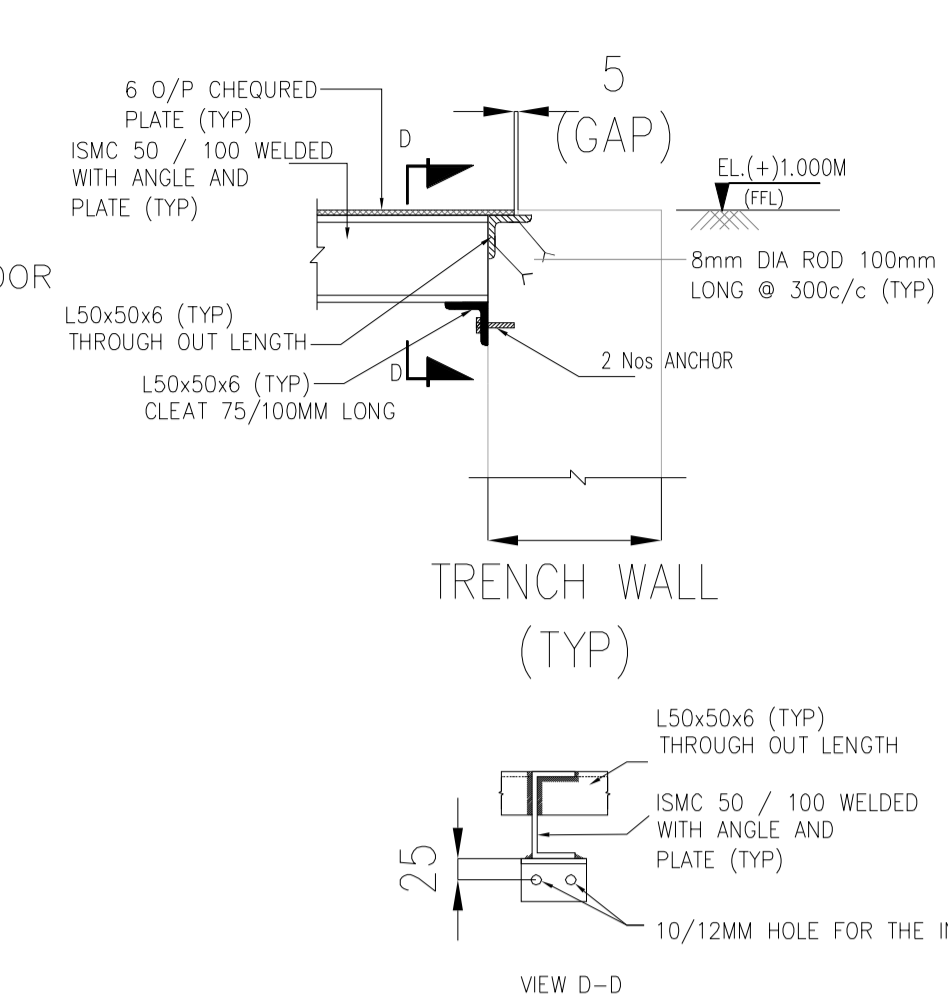

TYPICAL INSERT ARRANGEMENT IN THE TRENCH

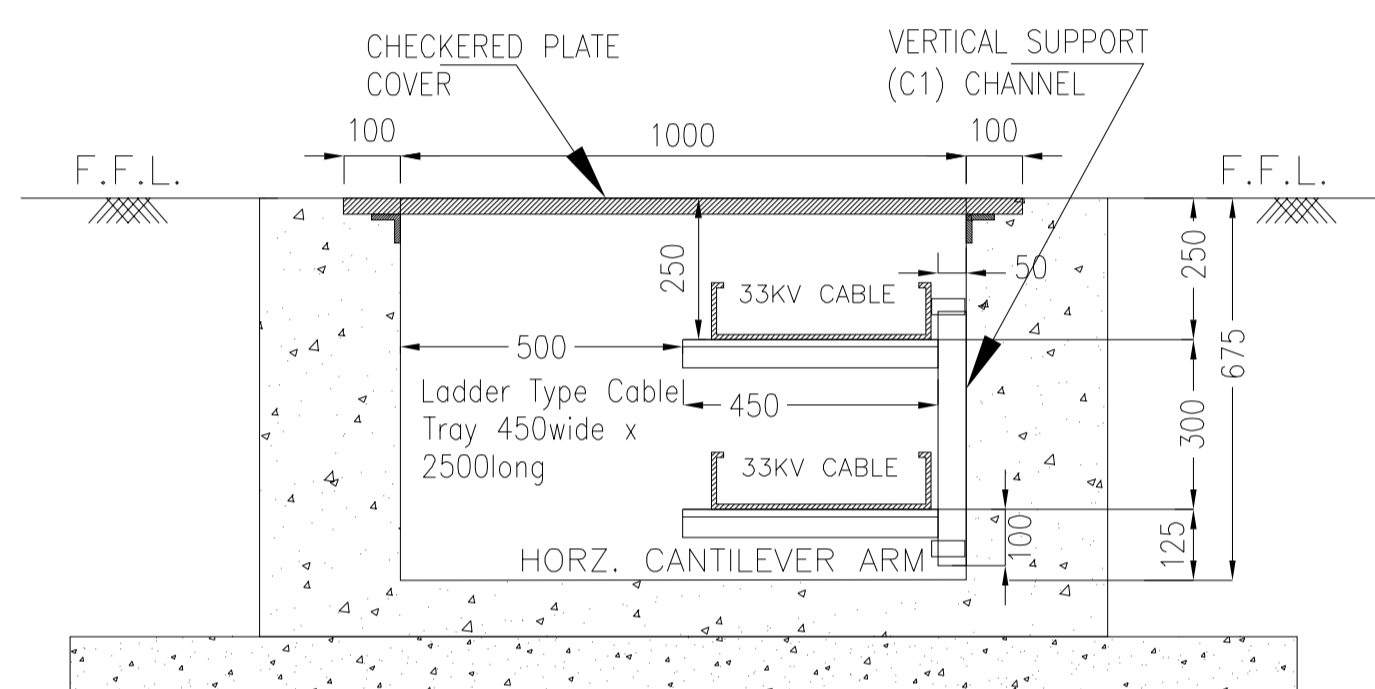

SECTION TR3

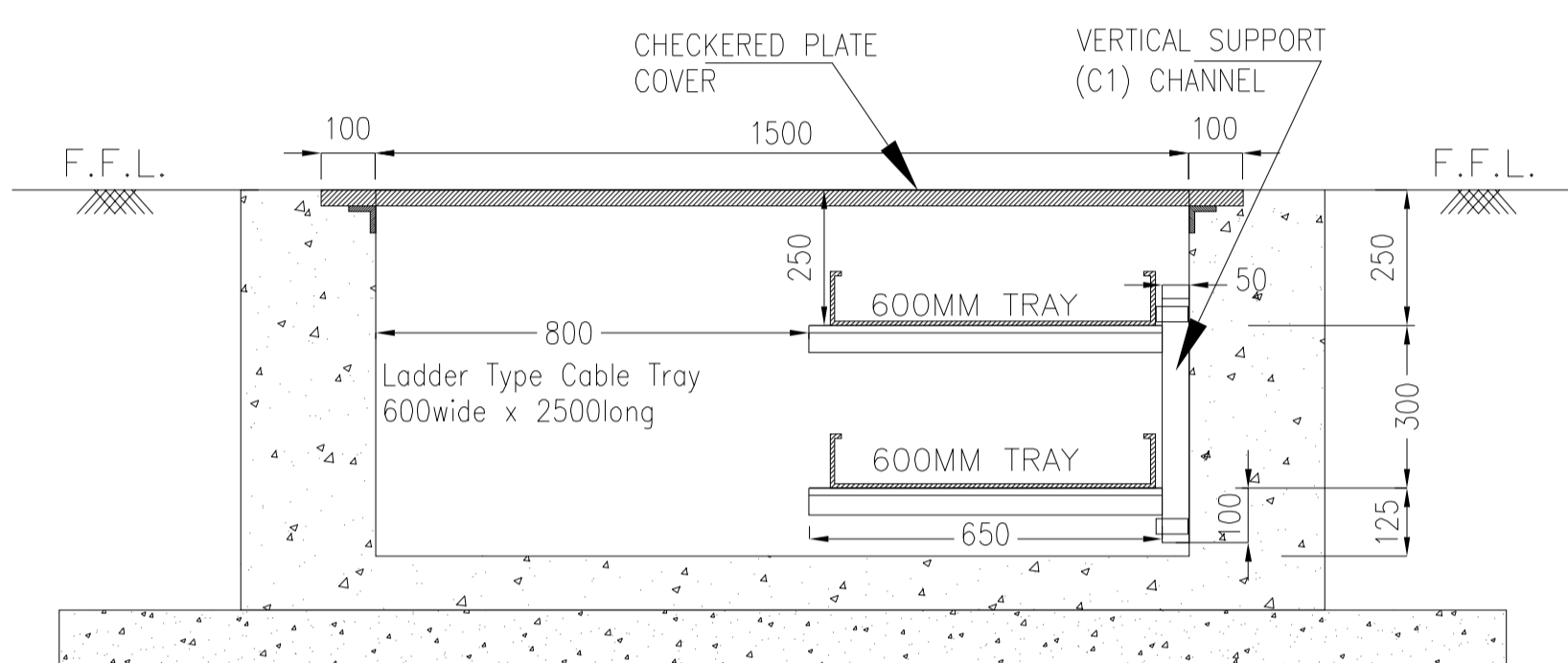

SECTION TR4

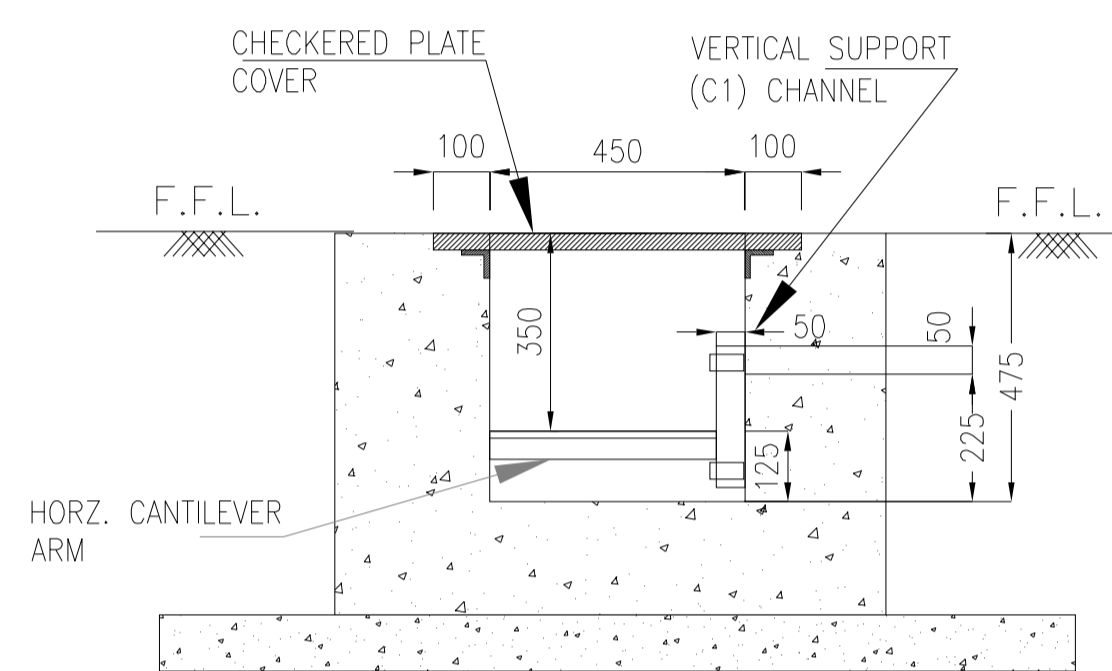

SECTION TR-6

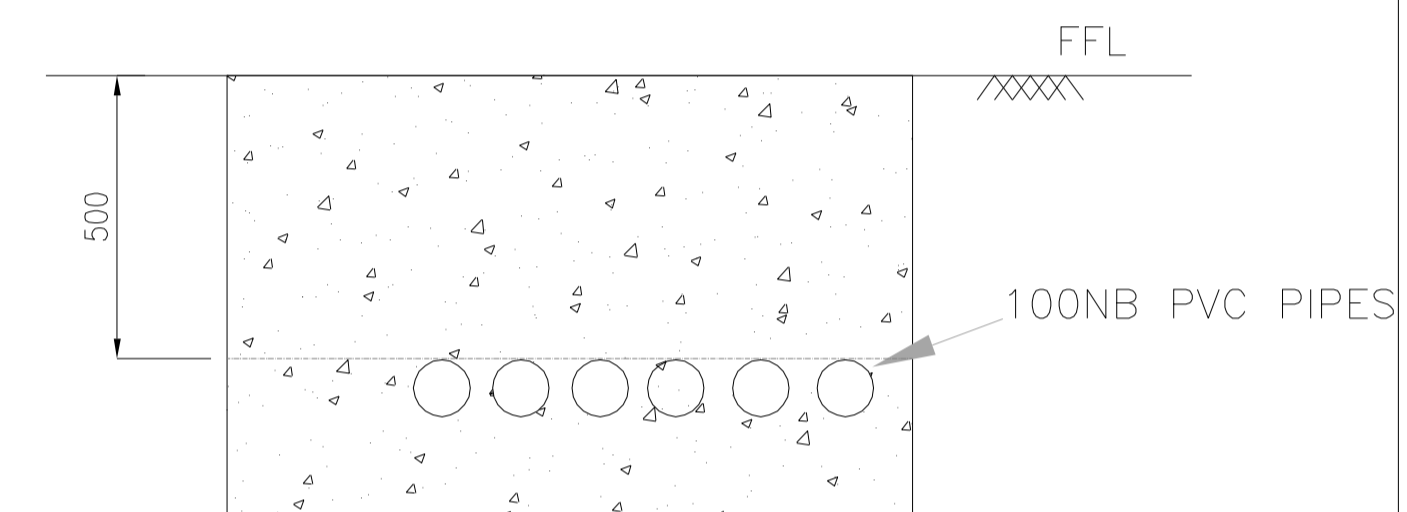

DETAIL Q

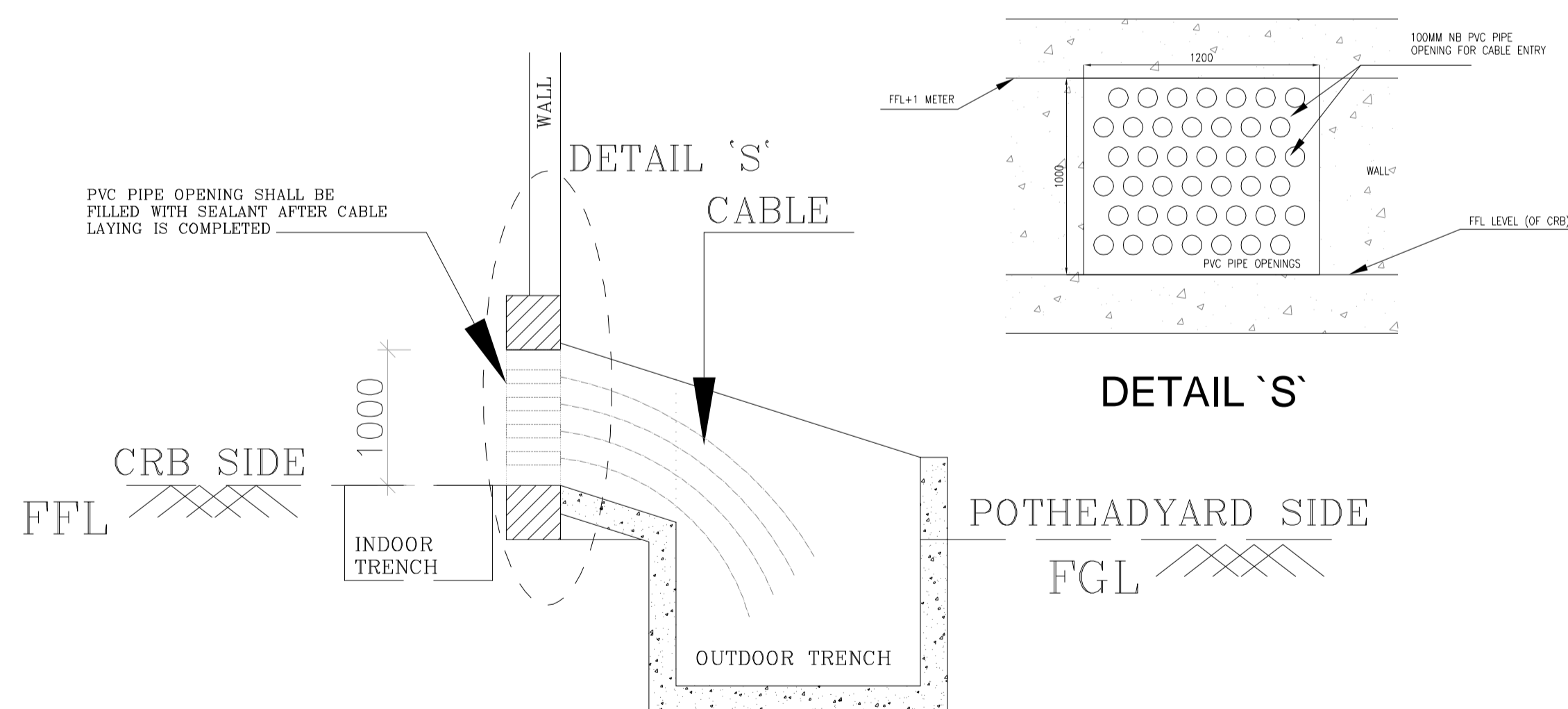

DETAIL-"M"

TYPICAL CABLE ENTRY ARRANGEMENT INTO CRP ROOM (FOR ALL TYPE OF ENTRY)

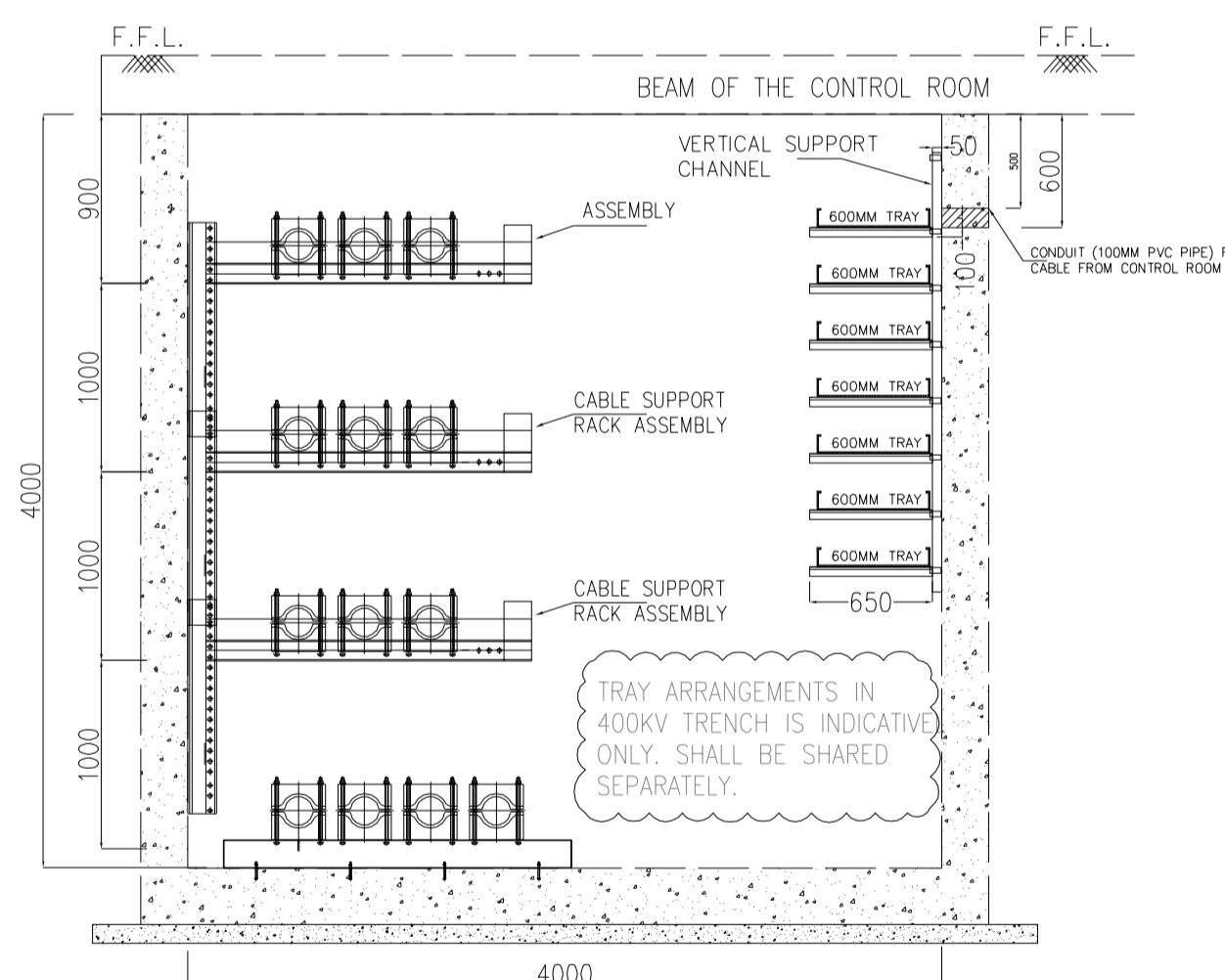

DETAIL 'S'

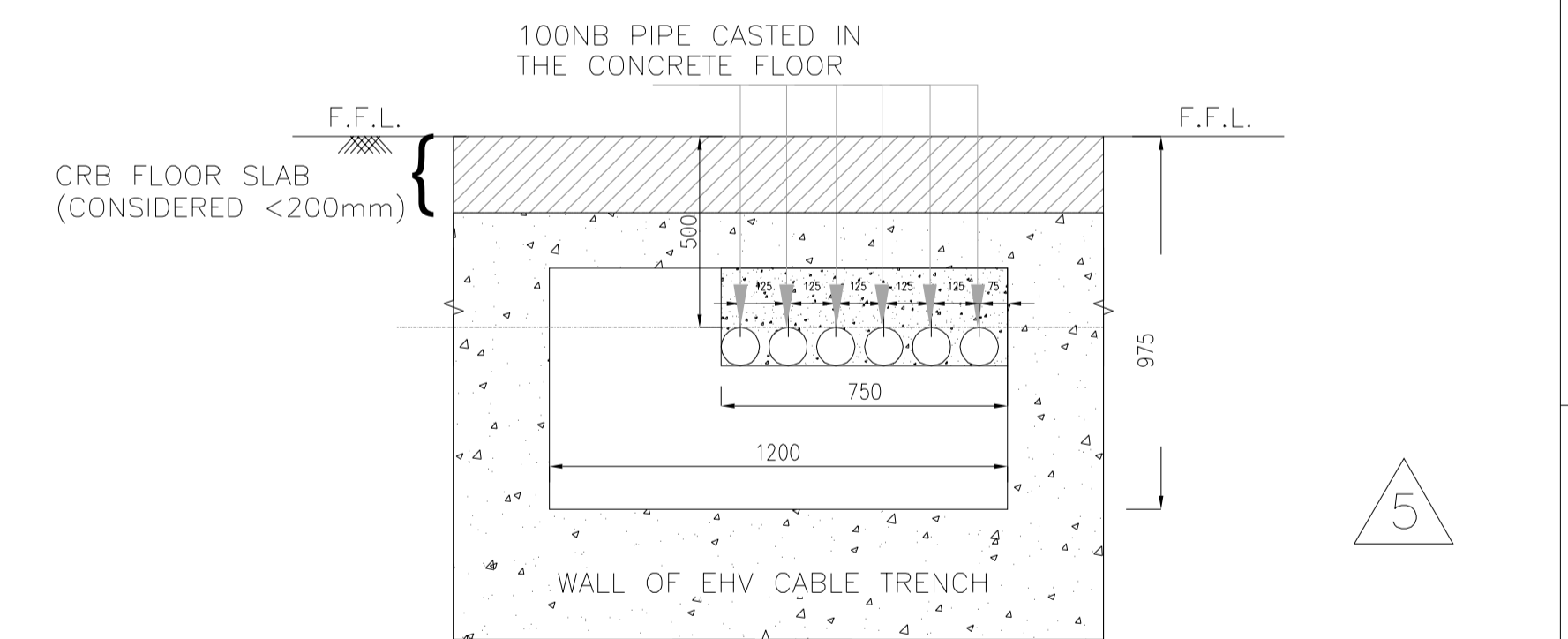

DETAIL-P

REV.	DATE	ALTERED	REV.	DATE	ALTERED
06	11.11.2021	CHD/APPD	05	03.11.2021	CHD/APPD
ZONE	THE DOCUMENT HAS BEEN REVISED BASED ON THE COMMENTS RECEIVED FROM THE CUSTOMER DATED 9 NOV .2021		ZONE	THE DOCUMENT HAS BEEN REVISED BASED ON THE COMMENTS RECEIVED FROM THE CUSTOMER DATED 21.09.2021 AND VC HELD BETWEEN BHEL AND SJVN DATED : 26.10.2021	
04	08.09.2021	CHD/APPD	03	30.06.2021	CHD/APPD
ZONE	THE DOCUMENT HAS BEEN REVISED BASED ON THE COMMENTS RECEIVED FROM THE CUSTOMER VIDE MEETING WITH SJVN AND TELECONFERENCE IN JUNE 2021 AND AUGUST 20.08.2021		ZONE	THE DOCUMENT HAS BEEN REVISED BASED ON THE COMMENTS RECEIVED FROM THE CUSTOMER VIDE MEETING WITH SJVN AND TELECONFERENCE IN JUNE 2021	
02	07.06.2021	CHD/APPD	01	05.03.2021	CHD/APPD
ZONE	THE DOCUMENT HAS BEEN REVISED BASED ON THE COMMENTS RECEIVED FROM THE CUSTOMER VIDE MOM DATED 19.03.2021 AND MEETING WITH SJVN		ZONE	THE DOCUMENT HAS BEEN REVISED BASED ON THE COMMENTS RECEIVED FROM THE CUSTOMER VIDE MOM DATED 23.02.2021	

PROJECT: ARUN-3 HYDRO ELECTRIC PROJECT (NEPAL)
(4 x 225 MW)

CUSTOMER: SJVN ARUN-3 POWER DEVELOPMENT COMPANY PVT. LTD. (SAPDC LTD.)

CONSULTANT: SJVN LTD.
(A JOINT VENTURE OF GOVT OF INDIA AND GOVT OF HP)

NAME	SIGN.	DATE
DRN. PK		30/10/2018
CHD. Vyom/JK		30/10/2018
APPD. SKS		30/10/2018

DEPT. TBG	SCALE NTS	CARD CODE
-----------	-----------	-----------

TITLE: CONCEPTUAL LAYOUT of CRP ROOM IN SWITCHGEAR BUILDING OF 400KV SWITCHYARD OF ARUN 3 HEP

DRG.NO. TB-3-405-316-021

REV. 6

SHT. No 4 NO. OF SHT. 05

THE INFORMATION ON THIS DOCUMENT IS THE PROPERTY OF BHARAT HEAVY ELECTRICALS LIMITED. IT MUST NOT BE USED DIRECTLY OR INDIRECTLY IN ANY WAY DETRIMENTAL TO THE INTEREST OF THE COMPANY

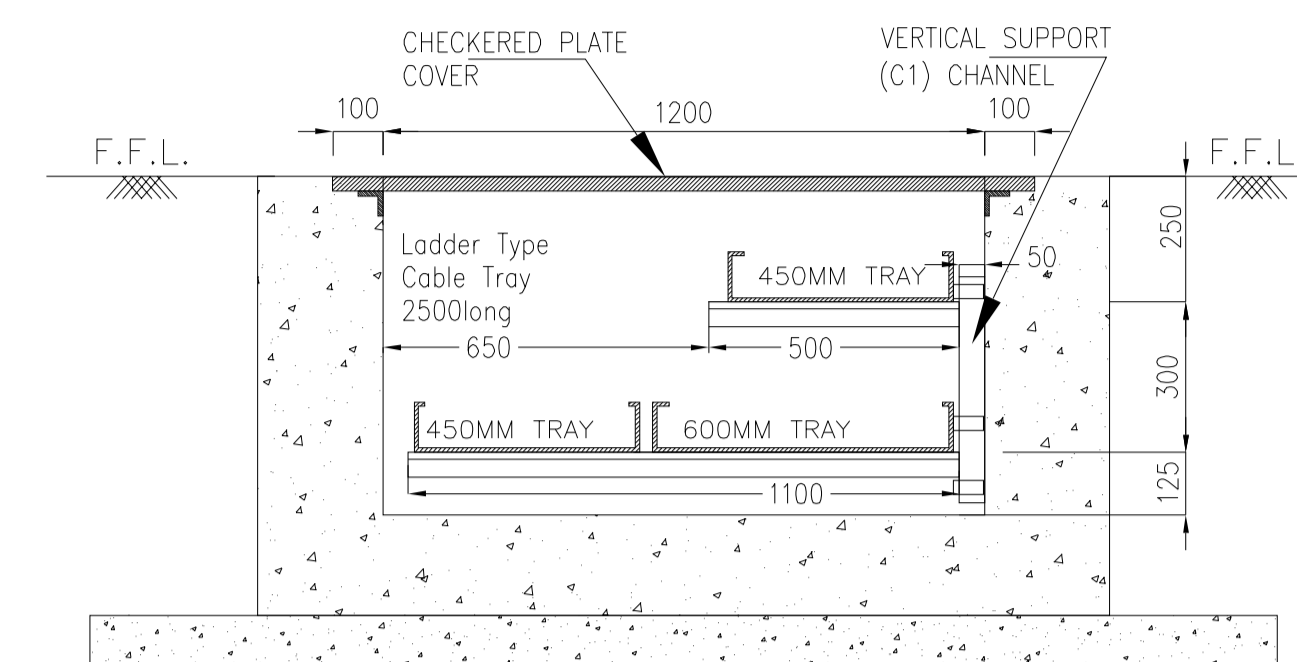
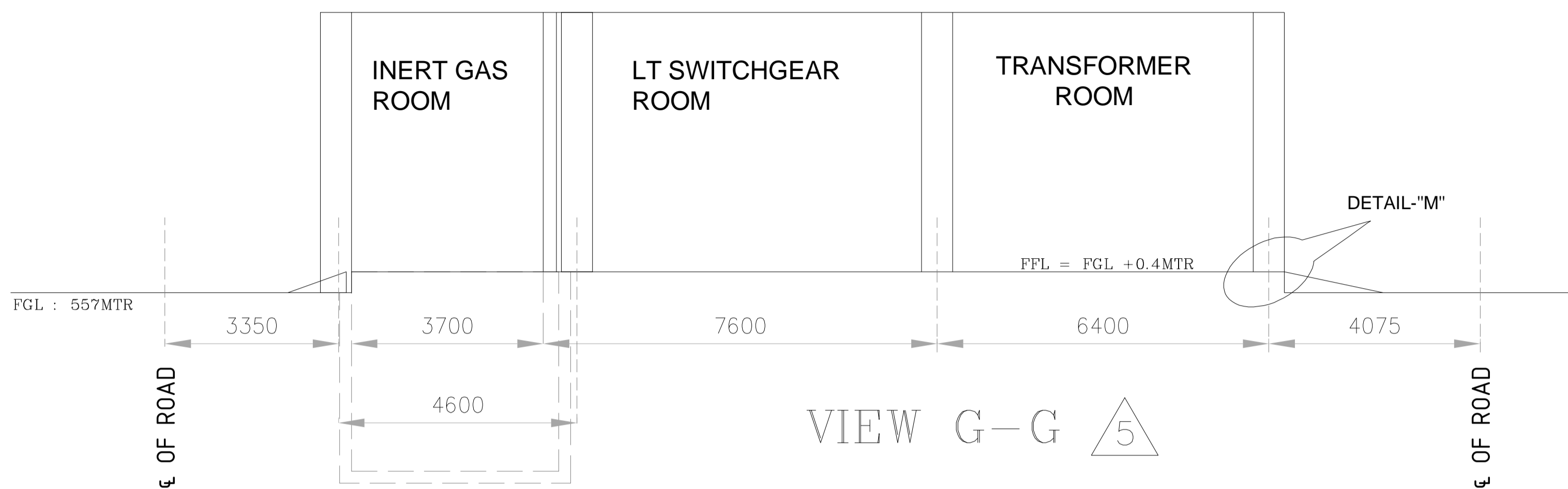

SECTION TR-7

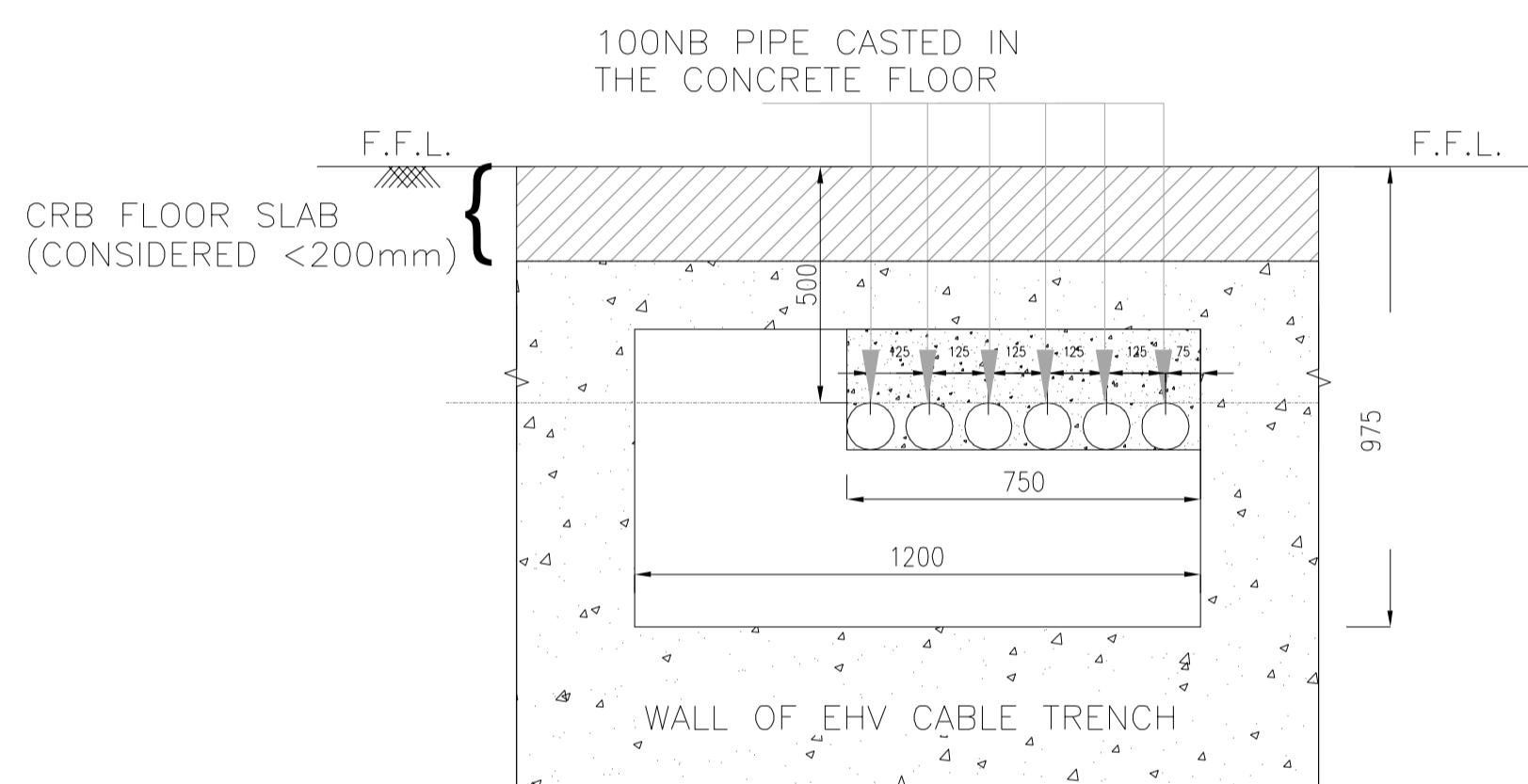

DETAIL-P1 6

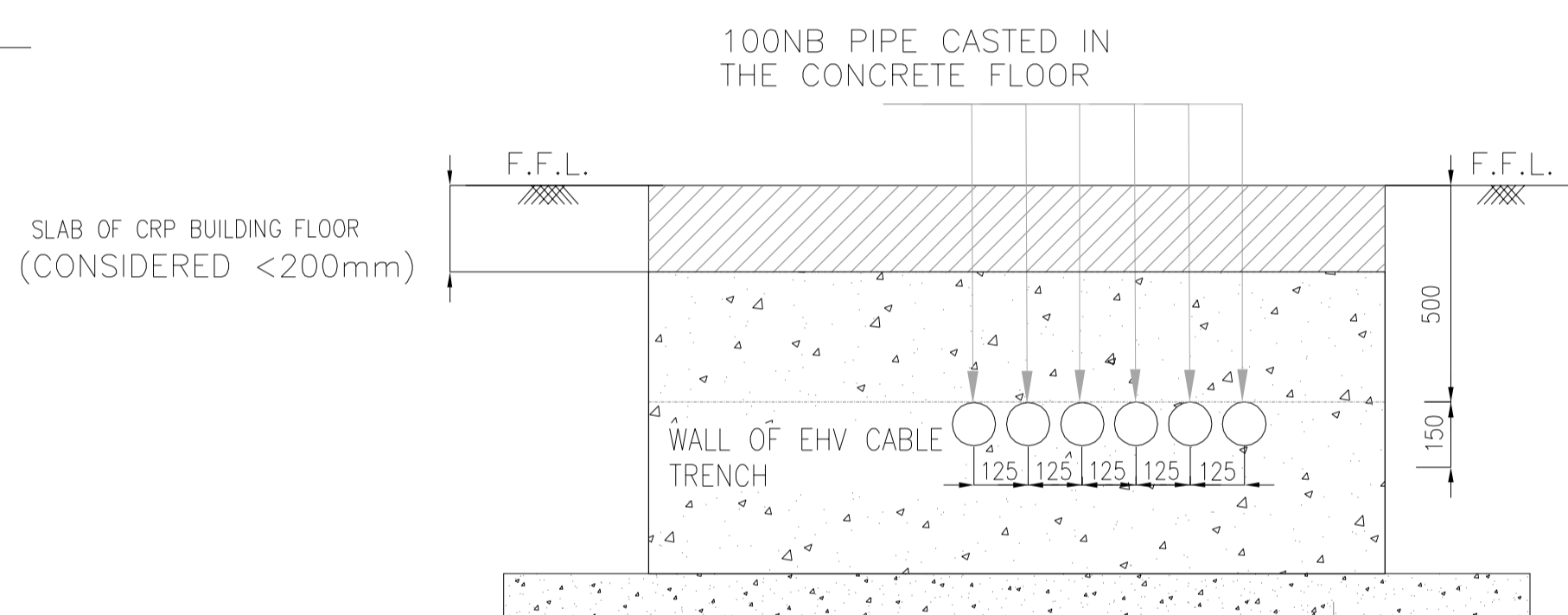

DETAIL-Q1

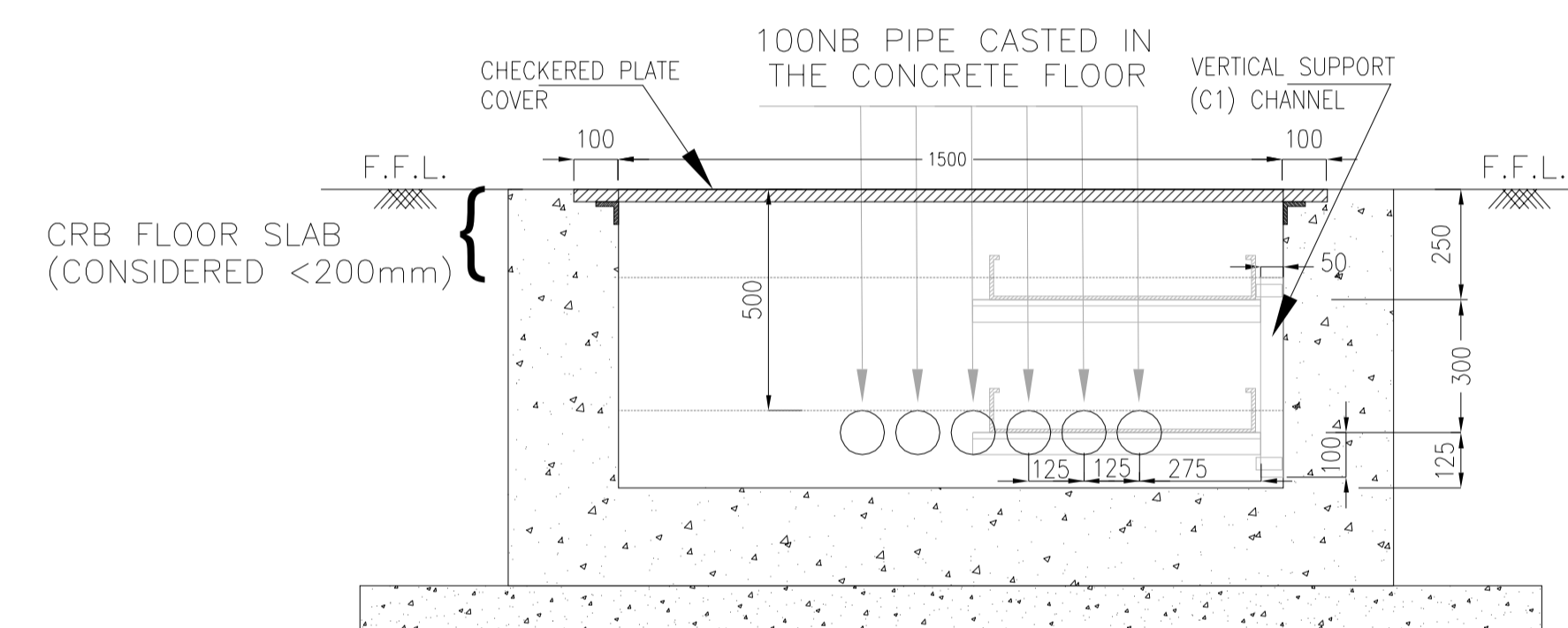

DETAIL-Q2

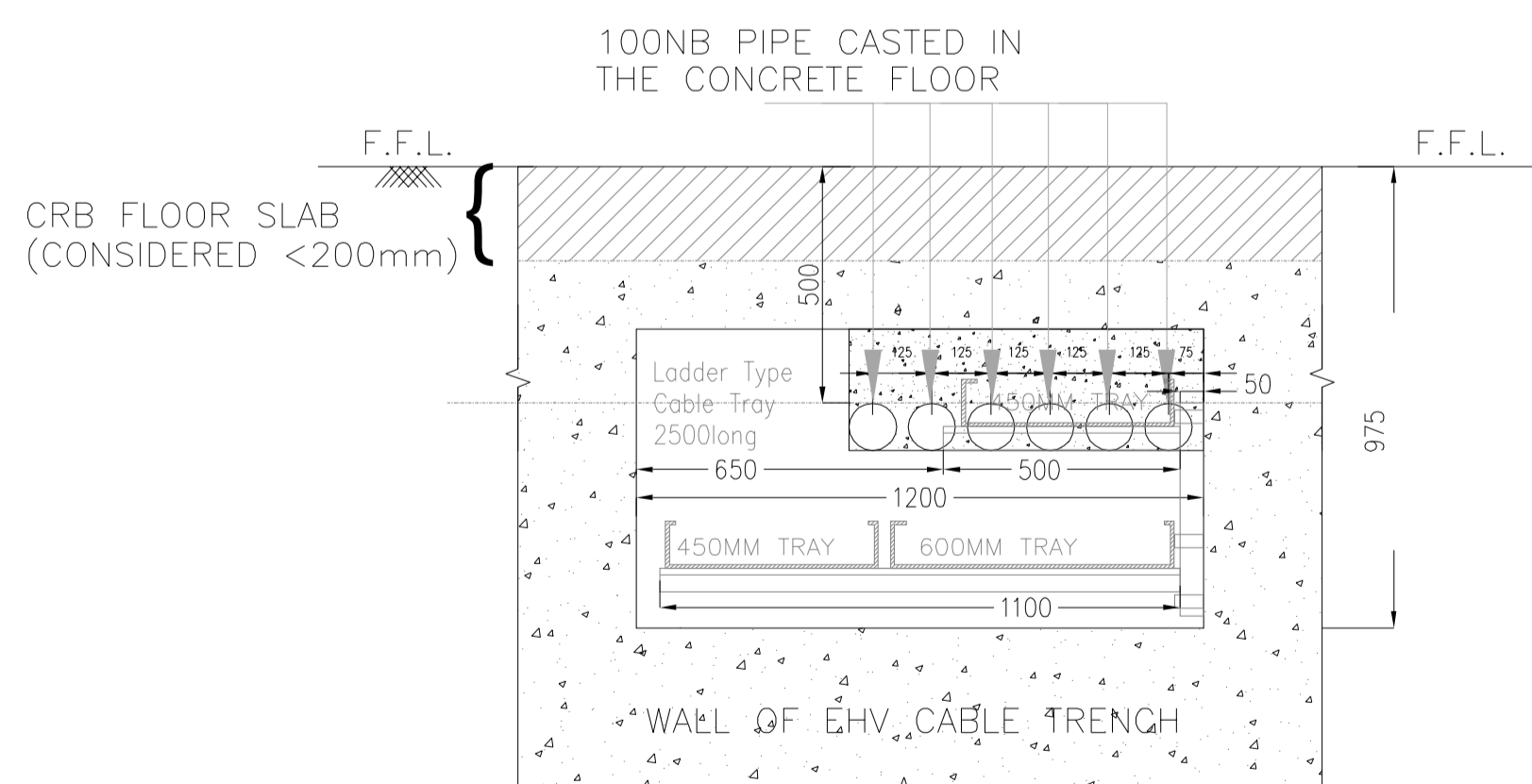

DETAIL-P2 6

REV. 04	DATE 08.09.2021	ALTERED CHD/APPD	REV. 03	DATE 30.06.2021	ALTERED CHD/APPD
ZONE	THE DOCUMENT HAS BEEN REVISED BASED ON THE COMMENTS RECEIVED FROM THE CUSTOMER VIDE MEETING WITH SJVN AND TELECONFERENCE IN JUNE 2021 AND AUGUST 20.08.2021		ZONE	THE DOCUMENT HAS BEEN REVISED BASED ON THE COMMENTS RECEIVED FROM THE CUSTOMER VIDE MEETING WITH SJVN AND TELECONFERENCE IN JUNE 2021	

REV. 06	DATE 11.11.2021	ALTERED CHD/APPD	REV. 05	DATE 03.11.2021	ALTERED CHD/APPD
ZONE	THE DOCUMENT HAS BEEN REVISED BASED ON THE COMMENTS RECEIVED FROM THE CUSTOMER DATED 9 NOV .2021		ZONE	THE DOCUMENT HAS BEEN REVISED BASED ON THE COMMENTS RECEIVED FROM THE CUSTOMER DATED 21.09.2021 AND VC HELD BETWEEN BHEL AND SJVN DATED : 26.10.2021	
REV. 02	DATE 07.06.2021	ALTERED CHD/APPD	REV. 01	DATE 05.03.2021	ALTERED CHD/APPD
ZONE	THE DOCUMENT HAS BEEN REVISED BASED ON THE COMMENTS RECEIVED FROM THE CUSTOMER VIDE MOM DATED 19.03.2021 AND MEETING WITH SJVN		ZONE	THE DOCUMENT HAS BEEN REVISED BASED ON THE COMMENTS RECEIVED FROM THE CUSTOMER VIDE MOM DATED 23.02.2021	

PROJECT: ARUN-3 HYDRO ELECTRIC PROJECT (NEPAL) (4 x 225 MW)

CUSTOMER: SJVN ARUN-3 POWER DEVELOPMENT COMPANY PVT. LTD. (SAPDC LTD.)

CONSULTANT: SJVN LTD. (A JOINT VENTURE OF GOVT OF INDIA AND GOVT OF HP)

NAME	SIGN.	DATE
DRN. PK		30/10/2018
CHD. Vyom./JK		30/10/2018
APPD. SKS		30/10/2018

DEPT. TBG	SCALE NTS	CARD CODE
-----------	-----------	-----------

TITLE: CONCEPTUAL LAYOUT of CRP ROOM IN SWITCHGEAR BUILDING OF 400kV SWITCHYARD OF ARUN 3 HEP

DRG.NO. TB-3-405-316-021 REV. 6

SHT. No 5 NO. OF SHT. 05

THE INFORMATION ON THIS DOCUMENT IS THE PROPERTY OF BHARAT HEAVY ELECTRICALS LIMITED. IT MUST NOT BE USED DIRECTLY OR INDIRECTLY IN ANY WAY DETRIMENTAL TO THE INTEREST OF THE COMPANY

* The document is approved with comments:-

1. Drawing shall be reviewed after placement of PO of of 400kV XLPE Vendor & finalisation of HV bushing of Reactor at respective interface location.
2. Reactor placement shall be reviewed after approval of revised Switchyard Layout incorporating proposed reactor placement.
3. For interface management, please refer BHEL reply vide CRS no. 1HYG900079-2-CRS dated 10.12.21 submitted along with Rev.02 of GIS Layout on 13.12.21.

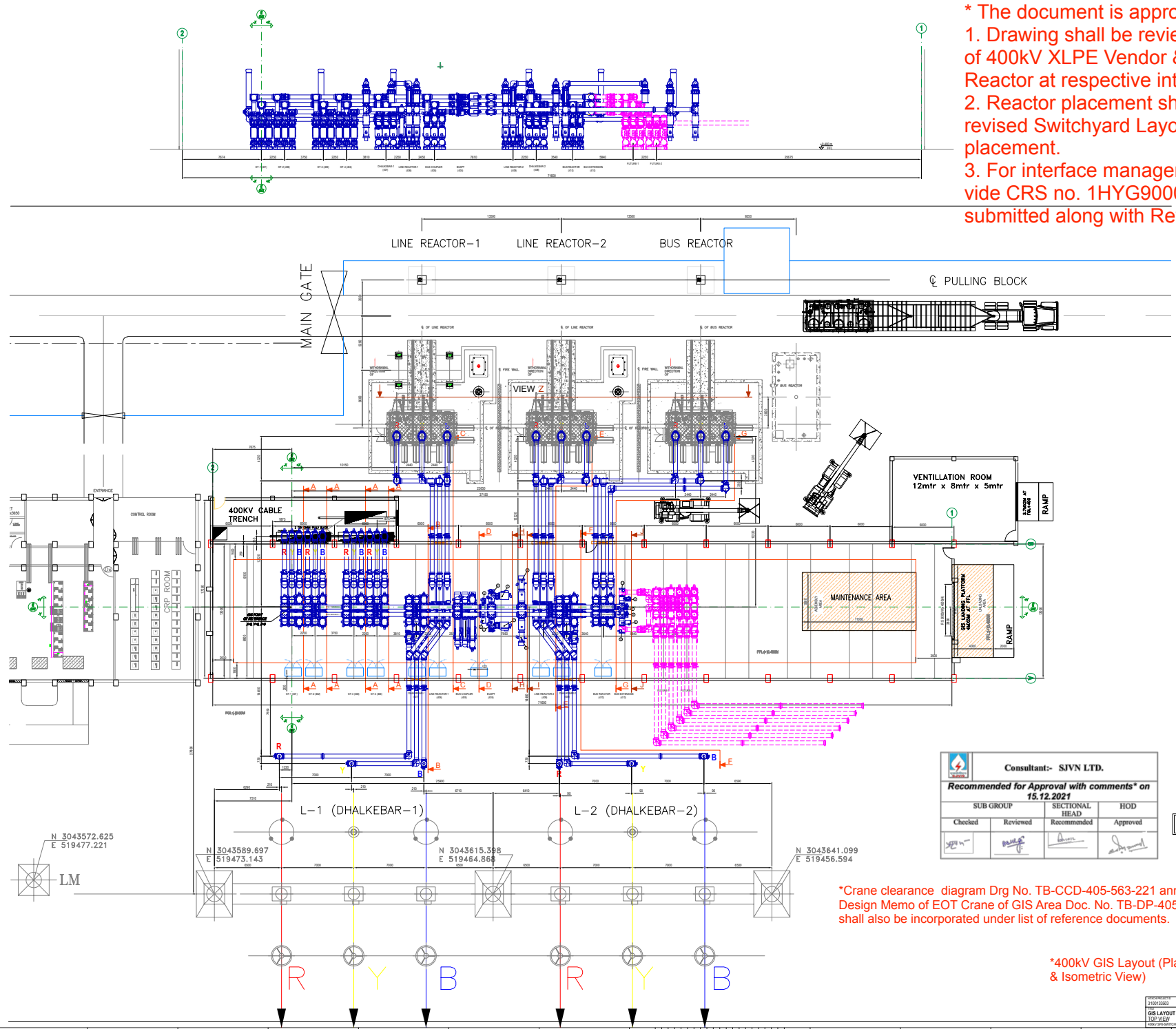

एनएसईएल अर्चन-3 पावर डेवलपमेंट कंपनी प्रा. लि.
SJVN Arun-3 Power Development Company Pvt. Ltd.
 900 MW Arun-3 Hybrid Power Project
 Reg. No. 111664970

Category: **Approval with comments**

Approved by Consultant	<i>[Signature]</i>	<i>[Signature]</i>	<i>[Signature]</i>
<input checked="" type="checkbox"/> Yes <input type="checkbox"/> No	Reviewed	Recommended	Approved

GIS (SCOPE OF SUPPLY) _____
 GIS (FUTURE) _____

- NOTES**
1. ALL DIMENSIONS ARE IN MILLIMETRES UNLESS OTHERWISE NOTED.
 2. CIVIL DETAILS (DOORS / STAIRS / LAND STEEL STRUCTURE ON THE DRAWING ARE FOR INFORMATION ONLY. FOR DETAILS REFER TO RELEVANT DRAWINGS.
 3. BHEL SHOULD INFORM ABB ABOUT OTHER INSTALLATION SUCH AS AIR CONDITIONING (DUCTING PANELS, ETC.) IN GIS HALL, IN ORDER TO AVOID COLLISION WITH GIS / GIS SUPPORT STRUCTURES.
 4. * MARK DIMENSIONS ARE YET TO CONFIRMED BY BHEL TEAM.

LEGEND

1 - CIRCUIT BREAKER
2 - DISCONNECTOR
3 - DISCONNECTOR & EARTHING SWITCH
4 - HIGH SPEED EARTHING SWITCH
5 - CURRENT TRANSFORMER
6 - 400KV SLD
7 - 400V TAGE TRANSFORMER
8 - SURGE ARRESTER
9 - SF6 TO AIR BUSHING
10 - CABLE END BOX
11 - TRANSFORMER CONNECTION
12 - LOCAL CONTROL CABLE (LCC)
13 - EXTENSION MODULE

REFERENCE DOCUMENTS

Document Title	ABB Doc. No.	CLIENT Doc. No.
PROJECT SPECIFIC GIS PARAMETERS	HYG000079.6	TB-405-317-02.3
SLD	HYG000079.1	TB-405-317-02.1
CIVIL WORK REQUIREMENTS	HYG000079.3	TB-405-317-02.10
400KV SLD	-	TB-405-317-02.1
SWITCHYARD LAYOUT	HYG000080.1	TB-405-316-01
SLD (GT HALL)	HYG000080.2	TB-405-317-02.2
GIS LAYOUT (GT HALL)	HYG000080.2	TB-405-317-02.2

Consultant:- **SJVN LTD.**

Recommended for Approval with comments* on 15.12.2021

SUB GROUP		SECTIONAL HEAD	HOD
Checked	Reviewed	Recommended	Approved
<i>[Signature]</i>	<i>[Signature]</i>	<i>[Signature]</i>	<i>[Signature]</i>

BASE DESIGN

*Crane clearance diagram Drg No. TB-CCD-405-563-221 annexed with Design Memo of EOT Crane of GIS Area Doc. No. TB-DP-405-563-221 shall also be incorporated under list of reference documents.

*400kV GIS Layout (Plan, Section & Isometric View)

PROJECT ARUN-3 HYBRID ELECTRIC POWER PROJECT (NEPAL) (4x225 MW)

CLIENT SJVN ARUN-3 POWER DEVELOPMENT COMPANY (P) LTD.

CONSULTANT SJVN LTD.

CONTRACTOR HITACHI ENERGY INDIA LTD.

REVISIONS

NO.	DATE	BY	REASON
01	09.12.2021	DEBASISH M	MODIFIED AS PER CUSTOMER COMMENTS
02	29.12.2021	DEBASISH M	MODIFIED AS PER CUSTOMER COMMENTS
03	14.12.2021	DEBASISH M	FIRST ISSUE

TITLE ELECTRICAL LAYOUT PLAN AND SECTION OF 4x225MW OF ARUN-3 HEP

DRG. NO.	REV.	DATE	BY
TB-405-317-10-2	02	09.12.2021	DEBASISH M
		09.12.2021	DEBASISH M
		09.12.2021	DEBASISH M

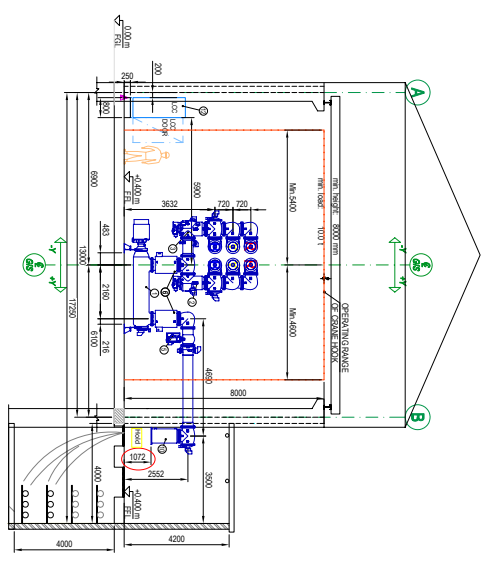

SECTION A-A (GT -1/GT -2/GT -3/GT -4)

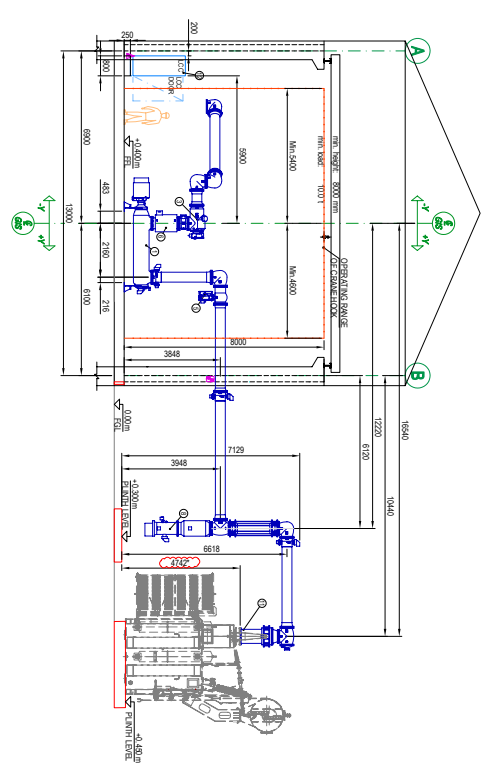

SECTION C-C (LINE REACTOR - 1)

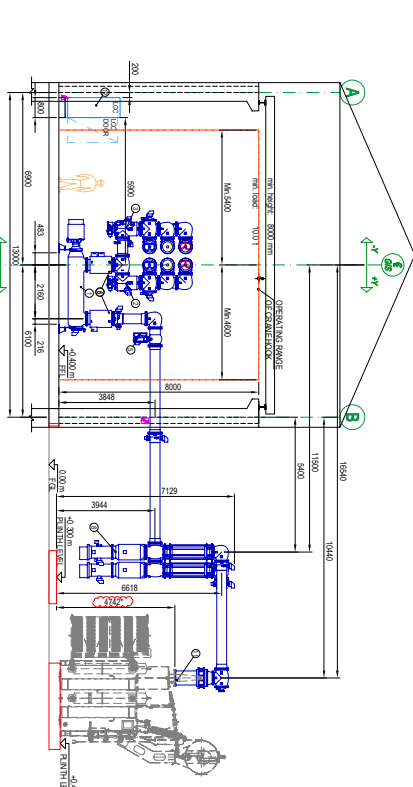

SECTION G-G (BUS REACTOR)

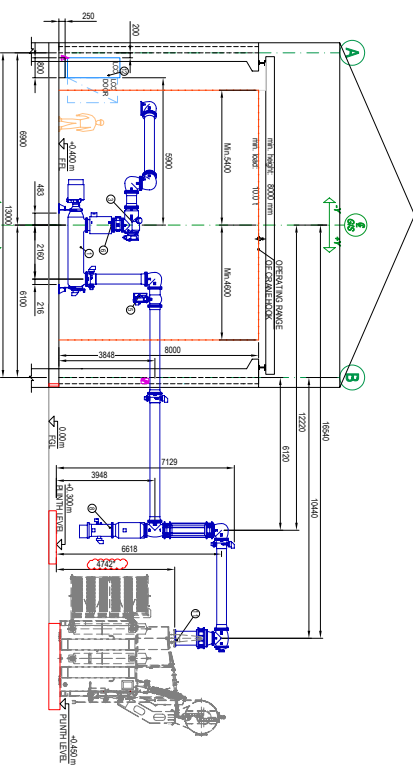

SECTION E-E (LINE REACTOR-2)

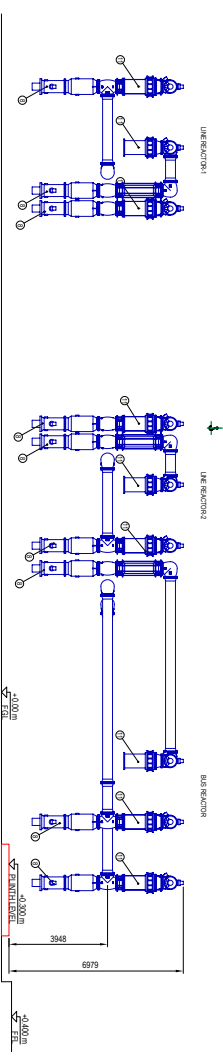

VIEW Z

GIS (SCOPE OF SUPPLY)

GIS (FUTURE)

- NOTES**
1. ALL DIMENSIONS ARE IN MILLIMETERS UNLESS OTHERWISE NOTED.
 2. IN THE EVENT OF CONFLICT BETWEEN DIMENSIONS, THE DIMENSION WITH THE LARGER VALUE SHALL PREVAIL.
 3. DIMENSIONS OF THE REACTOR SHALL BE AS PER THE DIMENSIONS SHOWN IN THE REACTOR DATA SHEET.
 4. DIMENSIONS OF THE REACTOR SHALL BE AS PER THE DIMENSIONS SHOWN IN THE REACTOR DATA SHEET.

LEGEND

1. CONDUIT PIPE
2. CONDUIT TRAY
3. CONDUIT TRAY BRACKET
4. CONDUIT TRAY BRACKET
5. CONDUIT TRAY BRACKET
6. CONDUIT TRAY BRACKET
7. CONDUIT TRAY BRACKET
8. CONDUIT TRAY BRACKET
9. CONDUIT TRAY BRACKET
10. CONDUIT TRAY BRACKET
11. CONDUIT TRAY BRACKET
12. CONDUIT TRAY BRACKET
13. CONDUIT TRAY BRACKET

REFERENCE DOCUMENTS

NO.	DESCRIPTION	DATE	ISSUED BY
1	PROJECT SITE DATA SHEET	18.06.2022	18.06.2022
2	CONDUIT TRAY DATA SHEET	18.06.2022	18.06.2022
3	CONDUIT TRAY DATA SHEET	18.06.2022	18.06.2022
4	CONDUIT TRAY DATA SHEET	18.06.2022	18.06.2022
5	CONDUIT TRAY DATA SHEET	18.06.2022	18.06.2022
6	CONDUIT TRAY DATA SHEET	18.06.2022	18.06.2022
7	CONDUIT TRAY DATA SHEET	18.06.2022	18.06.2022
8	CONDUIT TRAY DATA SHEET	18.06.2022	18.06.2022
9	CONDUIT TRAY DATA SHEET	18.06.2022	18.06.2022
10	CONDUIT TRAY DATA SHEET	18.06.2022	18.06.2022
11	CONDUIT TRAY DATA SHEET	18.06.2022	18.06.2022
12	CONDUIT TRAY DATA SHEET	18.06.2022	18.06.2022
13	CONDUIT TRAY DATA SHEET	18.06.2022	18.06.2022

BASE DESIGN

NO.	DESCRIPTION	DATE	ISSUED BY
1	PROJECT SITE DATA SHEET	18.06.2022	18.06.2022
2	CONDUIT TRAY DATA SHEET	18.06.2022	18.06.2022
3	CONDUIT TRAY DATA SHEET	18.06.2022	18.06.2022
4	CONDUIT TRAY DATA SHEET	18.06.2022	18.06.2022
5	CONDUIT TRAY DATA SHEET	18.06.2022	18.06.2022
6	CONDUIT TRAY DATA SHEET	18.06.2022	18.06.2022
7	CONDUIT TRAY DATA SHEET	18.06.2022	18.06.2022
8	CONDUIT TRAY DATA SHEET	18.06.2022	18.06.2022
9	CONDUIT TRAY DATA SHEET	18.06.2022	18.06.2022
10	CONDUIT TRAY DATA SHEET	18.06.2022	18.06.2022
11	CONDUIT TRAY DATA SHEET	18.06.2022	18.06.2022
12	CONDUIT TRAY DATA SHEET	18.06.2022	18.06.2022
13	CONDUIT TRAY DATA SHEET	18.06.2022	18.06.2022

***400KV GIS Layout (Plan, Section & Isometric View)**

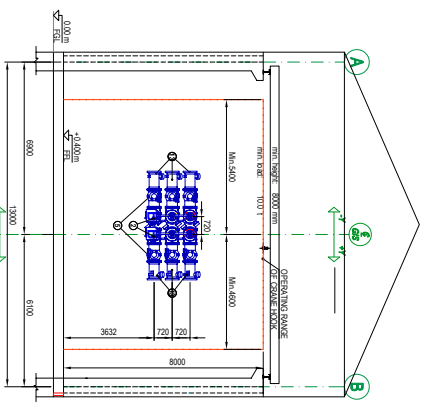
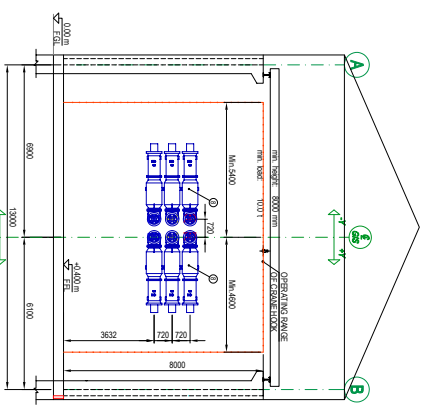
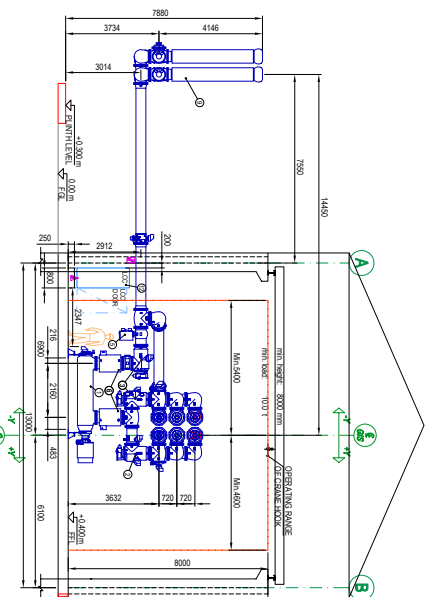
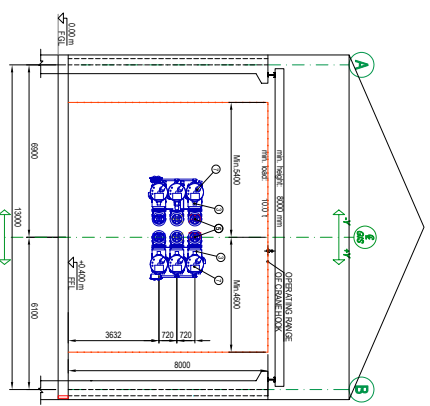
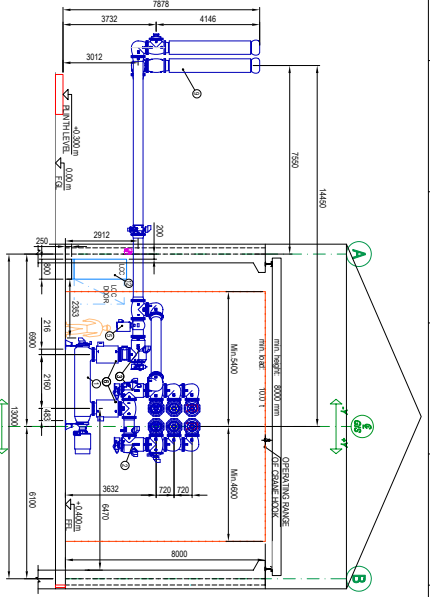
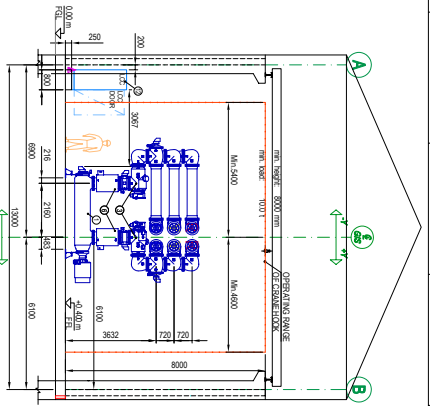

GIS (SCOPE OF SUPPLY)
 GIS (FUTURE)

- NOTES**
1. ALL DIMENSIONS ARE IN MILLIMETERS UNLESS OTHERWISE NOTED.
 2. FOR VERIFICATION OF DIMENSIONS, PLEASE REFER TO THE DRAWING FOR THE DIMENSIONS OF THE BUSBAR AND THE DIMENSIONS OF THE BUSBAR SUPPORTS.
 3. OPERATING DIMENSIONS ARE GIVEN IN ORDER TO AVOID COLLISIONS.
 4. WHEN DIMENSIONS ARE NOT TO OPERATING DIMENSIONS.

LEGEND

1. OPERATING DIMENSIONS	2. DIMENSIONS TO OPERATING DIMENSIONS
3. DIMENSIONS TO OPERATING DIMENSIONS	4. DIMENSIONS TO OPERATING DIMENSIONS
5. DIMENSIONS TO OPERATING DIMENSIONS	6. DIMENSIONS TO OPERATING DIMENSIONS
7. DIMENSIONS TO OPERATING DIMENSIONS	8. DIMENSIONS TO OPERATING DIMENSIONS
9. DIMENSIONS TO OPERATING DIMENSIONS	10. DIMENSIONS TO OPERATING DIMENSIONS
11. DIMENSIONS TO OPERATING DIMENSIONS	12. DIMENSIONS TO OPERATING DIMENSIONS
13. DIMENSIONS TO OPERATING DIMENSIONS	14. DIMENSIONS TO OPERATING DIMENSIONS

REFERENCE DOCUMENTS

Sl. No.	Document Name	Revision	Date
1	PROJECT REPORT	1.0	20/01/2022
2	PROJECT REPORT	1.0	20/01/2022
3	PROJECT REPORT	1.0	20/01/2022
4	PROJECT REPORT	1.0	20/01/2022
5	PROJECT REPORT	1.0	20/01/2022
6	PROJECT REPORT	1.0	20/01/2022
7	PROJECT REPORT	1.0	20/01/2022
8	PROJECT REPORT	1.0	20/01/2022
9	PROJECT REPORT	1.0	20/01/2022
10	PROJECT REPORT	1.0	20/01/2022

BASE DESIGN

Sl. No.	Document Name	Revision	Date
1	PROJECT REPORT	1.0	20/01/2022
2	PROJECT REPORT	1.0	20/01/2022
3	PROJECT REPORT	1.0	20/01/2022
4	PROJECT REPORT	1.0	20/01/2022
5	PROJECT REPORT	1.0	20/01/2022
6	PROJECT REPORT	1.0	20/01/2022
7	PROJECT REPORT	1.0	20/01/2022
8	PROJECT REPORT	1.0	20/01/2022
9	PROJECT REPORT	1.0	20/01/2022
10	PROJECT REPORT	1.0	20/01/2022

Sl. No.	Document Name	Revision	Date
1	PROJECT REPORT	1.0	20/01/2022
2	PROJECT REPORT	1.0	20/01/2022
3	PROJECT REPORT	1.0	20/01/2022
4	PROJECT REPORT	1.0	20/01/2022
5	PROJECT REPORT	1.0	20/01/2022
6	PROJECT REPORT	1.0	20/01/2022
7	PROJECT REPORT	1.0	20/01/2022
8	PROJECT REPORT	1.0	20/01/2022
9	PROJECT REPORT	1.0	20/01/2022
10	PROJECT REPORT	1.0	20/01/2022

*400kV GIS Layout (Plan, Section & Isometric View)

Sl. No.	Document Name	Revision	Date
1	PROJECT REPORT	1.0	20/01/2022
2	PROJECT REPORT	1.0	20/01/2022
3	PROJECT REPORT	1.0	20/01/2022
4	PROJECT REPORT	1.0	20/01/2022
5	PROJECT REPORT	1.0	20/01/2022
6	PROJECT REPORT	1.0	20/01/2022
7	PROJECT REPORT	1.0	20/01/2022
8	PROJECT REPORT	1.0	20/01/2022
9	PROJECT REPORT	1.0	20/01/2022
10	PROJECT REPORT	1.0	20/01/2022

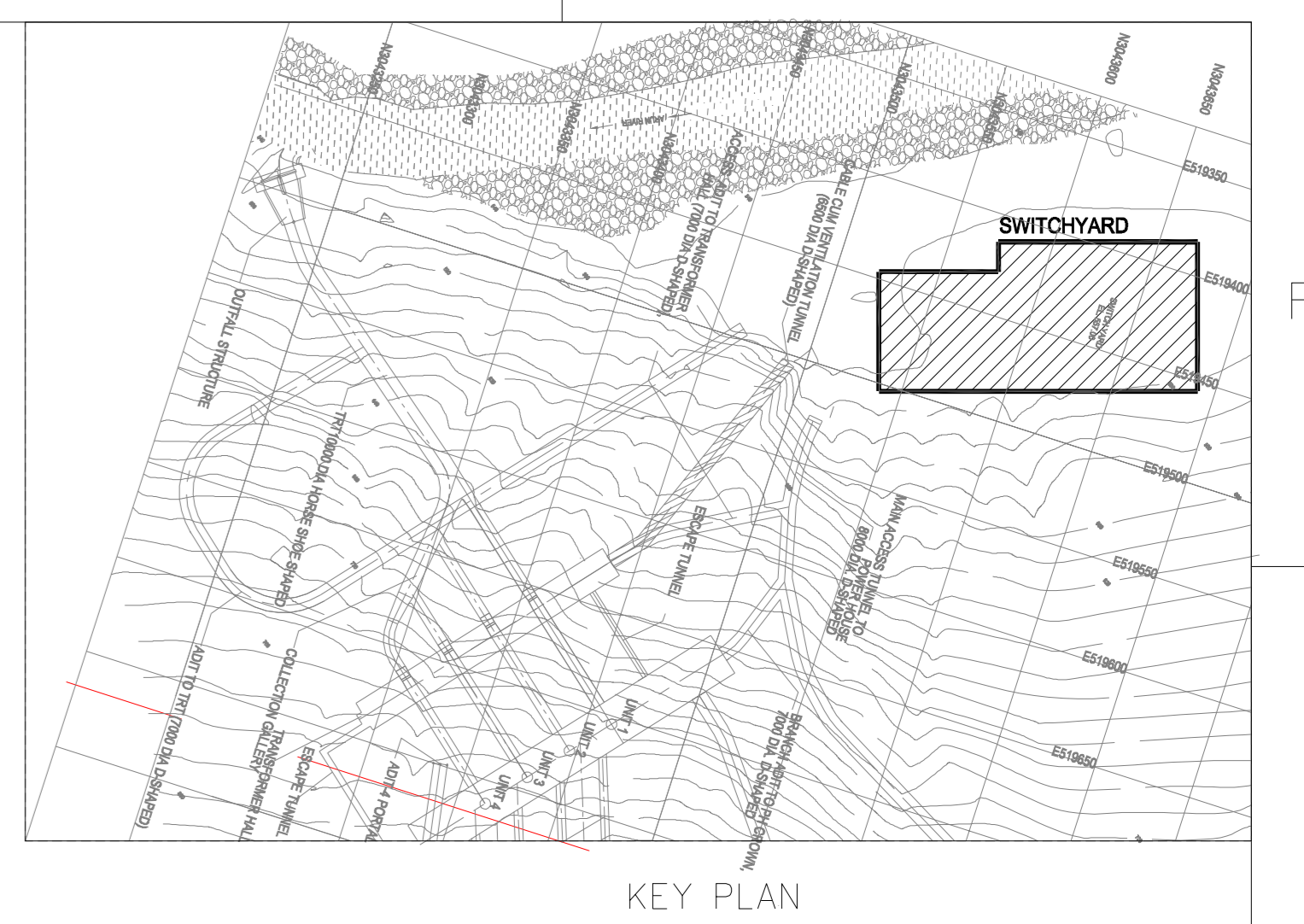
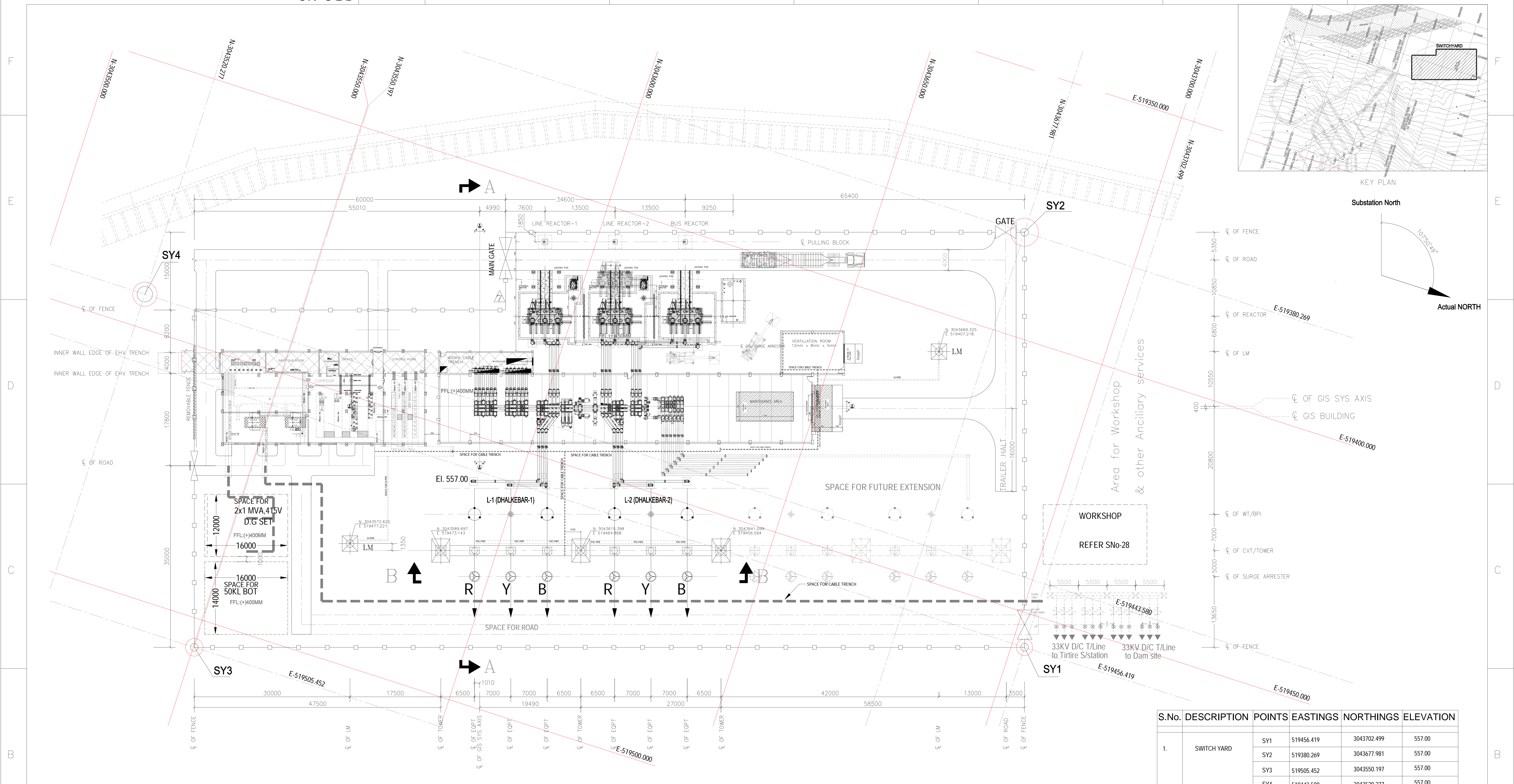

S.No.	DESCRIPTION	POINTS	EASTINGS	NORTHINGS	ELEVATION
1.	SWITCH YARD	SY1	519456.419	3043702.499	557.00
		SY2	519380.269	3043677.981	557.00
		SY3	519505.452	3043550.197	557.00
		SY4	519443.580	3043520.277	557.00

REV.	DATE	ALTERED	REV.	DATE	ALTERED	REV.	DATE	ALTERED	ADDITIONAL INFORMATION :	PROJECT:	
07	16/12/21	CHD/APPD	06	22/06/21	CHD/APPD	05	28/05/21	CHD/APPD	WO NO. :	ARUN-3 HYDRO ELECTRIC PROJECT (NEPAL) (4 x 225 MW)	
04	20/10/20	CHD/APPD	03	10/03/20	CHD/APPD	02	07/06/19	CHD/APPD	STATUS OF DRAWING :	CUSTOMER: SJVN ARUN-3 POWER DEVELOPMENT COMPANY PVT. LTD. (SAPDC LTD.)	
ZONE 1. DETAILS OF THE REACTOR AND REACTOR CUM NGR AREA INCLUDED. 2. DISTANCE BETWEEN THE REACTORS OPTIMISED. 3. REPRESENTATION OF THE REACTOR UNLOADING INCLUDED. 4. RAILS REMOVED FROM THE MAIN ROAD.			ZONE 1. Building for Ventilation Room is now limited for catering to the requirement of GIS.			ZONE 1. Building for Inert Gas System included. 2. Common Ventilation Room for Power House and GIS Building included. 3. Cable Trench shown for the CAT to Switchyard. 4. The Layout of the Transformer Cavern shall be part of shown in "Cross Section and Plan of Transformer Cavern - 1 200 00 20558. 5. Comments marked on Rev-01 incorporated.			DISTRIBUTION OF PRINTS :		CONSULTANT: SJVN LTD. (A JOINT VENTURE OF GOVT OF INDIA AND GOVT OF HP)
ZONE 1. DETAILS OF THE REACTOR AND REACTOR CUM NGR AREA INCLUDED. 2. DISTANCE BETWEEN THE REACTORS OPTIMISED. 3. REPRESENTATION OF THE REACTOR UNLOADING INCLUDED. 4. RAILS REMOVED FROM THE MAIN ROAD.			ZONE 1. Building for Ventilation Room is now limited for catering to the requirement of GIS.			ZONE 1. Building for Inert Gas System included. 2. Common Ventilation Room for Power House and GIS Building included. 3. Cable Trench shown for the CAT to Switchyard. 4. The Layout of the Transformer Cavern shall be part of shown in "Cross Section and Plan of Transformer Cavern - 1 200 00 20558. 5. Comments marked on Rev-01 incorporated.			REV. DATE ALTERED		NAME SIGN. DATE
ZONE 1. DETAILS OF THE REACTOR AND REACTOR CUM NGR AREA INCLUDED. 2. DISTANCE BETWEEN THE REACTORS OPTIMISED. 3. REPRESENTATION OF THE REACTOR UNLOADING INCLUDED. 4. RAILS REMOVED FROM THE MAIN ROAD.			ZONE 1. Building for Ventilation Room is now limited for catering to the requirement of GIS.			ZONE 1. Building for Inert Gas System included. 2. Common Ventilation Room for Power House and GIS Building included. 3. Cable Trench shown for the CAT to Switchyard. 4. The Layout of the Transformer Cavern shall be part of shown in "Cross Section and Plan of Transformer Cavern - 1 200 00 20558. 5. Comments marked on Rev-01 incorporated.			REV. DATE ALTERED		DRN. PK 30/10/2018
ZONE 1. DETAILS OF THE REACTOR AND REACTOR CUM NGR AREA INCLUDED. 2. DISTANCE BETWEEN THE REACTORS OPTIMISED. 3. REPRESENTATION OF THE REACTOR UNLOADING INCLUDED. 4. RAILS REMOVED FROM THE MAIN ROAD.			ZONE 1. Building for Ventilation Room is now limited for catering to the requirement of GIS.			ZONE 1. Building for Inert Gas System included. 2. Common Ventilation Room for Power House and GIS Building included. 3. Cable Trench shown for the CAT to Switchyard. 4. The Layout of the Transformer Cavern shall be part of shown in "Cross Section and Plan of Transformer Cavern - 1 200 00 20558. 5. Comments marked on Rev-01 incorporated.			REV. DATE ALTERED		CHD. Vyom/VK 30/10/2018
ZONE 1. DETAILS OF THE REACTOR AND REACTOR CUM NGR AREA INCLUDED. 2. DISTANCE BETWEEN THE REACTORS OPTIMISED. 3. REPRESENTATION OF THE REACTOR UNLOADING INCLUDED. 4. RAILS REMOVED FROM THE MAIN ROAD.			ZONE 1. Building for Ventilation Room is now limited for catering to the requirement of GIS.			ZONE 1. Building for Inert Gas System included. 2. Common Ventilation Room for Power House and GIS Building included. 3. Cable Trench shown for the CAT to Switchyard. 4. The Layout of the Transformer Cavern shall be part of shown in "Cross Section and Plan of Transformer Cavern - 1 200 00 20558. 5. Comments marked on Rev-01 incorporated.			REV. DATE ALTERED		APPD. SKS 30/10/2018
ZONE 1. DETAILS OF THE REACTOR AND REACTOR CUM NGR AREA INCLUDED. 2. DISTANCE BETWEEN THE REACTORS OPTIMISED. 3. REPRESENTATION OF THE REACTOR UNLOADING INCLUDED. 4. RAILS REMOVED FROM THE MAIN ROAD.			ZONE 1. Building for Ventilation Room is now limited for catering to the requirement of GIS.			ZONE 1. Building for Inert Gas System included. 2. Common Ventilation Room for Power House and GIS Building included. 3. Cable Trench shown for the CAT to Switchyard. 4. The Layout of the Transformer Cavern shall be part of shown in "Cross Section and Plan of Transformer Cavern - 1 200 00 20558. 5. Comments marked on Rev-01 incorporated.			REV. DATE ALTERED		DEPT. TBG CODE
ZONE 1. DETAILS OF THE REACTOR AND REACTOR CUM NGR AREA INCLUDED. 2. DISTANCE BETWEEN THE REACTORS OPTIMISED. 3. REPRESENTATION OF THE REACTOR UNLOADING INCLUDED. 4. RAILS REMOVED FROM THE MAIN ROAD.			ZONE 1. Building for Ventilation Room is now limited for catering to the requirement of GIS.			ZONE 1. Building for Inert Gas System included. 2. Common Ventilation Room for Power House and GIS Building included. 3. Cable Trench shown for the CAT to Switchyard. 4. The Layout of the Transformer Cavern shall be part of shown in "Cross Section and Plan of Transformer Cavern - 1 200 00 20558. 5. Comments marked on Rev-01 incorporated.			REV. DATE ALTERED		SCALE NTS
ZONE 1. DETAILS OF THE REACTOR AND REACTOR CUM NGR AREA INCLUDED. 2. DISTANCE BETWEEN THE REACTORS OPTIMISED. 3. REPRESENTATION OF THE REACTOR UNLOADING INCLUDED. 4. RAILS REMOVED FROM THE MAIN ROAD.			ZONE 1. Building for Ventilation Room is now limited for catering to the requirement of GIS.			ZONE 1. Building for Inert Gas System included. 2. Common Ventilation Room for Power House and GIS Building included. 3. Cable Trench shown for the CAT to Switchyard. 4. The Layout of the Transformer Cavern shall be part of shown in "Cross Section and Plan of Transformer Cavern - 1 200 00 20558. 5. Comments marked on Rev-01 incorporated.			REV. DATE ALTERED		CARD CODE
ZONE 1. DETAILS OF THE REACTOR AND REACTOR CUM NGR AREA INCLUDED. 2. DISTANCE BETWEEN THE REACTORS OPTIMISED. 3. REPRESENTATION OF THE REACTOR UNLOADING INCLUDED. 4. RAILS REMOVED FROM THE MAIN ROAD.			ZONE 1. Building for Ventilation Room is now limited for catering to the requirement of GIS.			ZONE 1. Building for Inert Gas System included. 2. Common Ventilation Room for Power House and GIS Building included. 3. Cable Trench shown for the CAT to Switchyard. 4. The Layout of the Transformer Cavern shall be part of shown in "Cross Section and Plan of Transformer Cavern - 1 200 00 20558. 5. Comments marked on Rev-01 incorporated.			REV. DATE ALTERED		TITLE
ZONE 1. DETAILS OF THE REACTOR AND REACTOR CUM NGR AREA INCLUDED. 2. DISTANCE BETWEEN THE REACTORS OPTIMISED. 3. REPRESENTATION OF THE REACTOR UNLOADING INCLUDED. 4. RAILS REMOVED FROM THE MAIN ROAD.			ZONE 1. Building for Ventilation Room is now limited for catering to the requirement of GIS.			ZONE 1. Building for Inert Gas System included. 2. Common Ventilation Room for Power House and GIS Building included. 3. Cable Trench shown for the CAT to Switchyard. 4. The Layout of the Transformer Cavern shall be part of shown in "Cross Section and Plan of Transformer Cavern - 1 200 00 20558. 5. Comments marked on Rev-01 incorporated.			REV. DATE ALTERED		DRG. NO. TB-3-405-316-001
ZONE 1. DETAILS OF THE REACTOR AND REACTOR CUM NGR AREA INCLUDED. 2. DISTANCE BETWEEN THE REACTORS OPTIMISED. 3. REPRESENTATION OF THE REACTOR UNLOADING INCLUDED. 4. RAILS REMOVED FROM THE MAIN ROAD.			ZONE 1. Building for Ventilation Room is now limited for catering to the requirement of GIS.			ZONE 1. Building for Inert Gas System included. 2. Common Ventilation Room for Power House and GIS Building included. 3. Cable Trench shown for the CAT to Switchyard. 4. The Layout of the Transformer Cavern shall be part of shown in "Cross Section and Plan of Transformer Cavern - 1 200 00 20558. 5. Comments marked on Rev-01 incorporated.			REV. DATE ALTERED		REV. 07
ZONE 1. DETAILS OF THE REACTOR AND REACTOR CUM NGR AREA INCLUDED. 2. DISTANCE BETWEEN THE REACTORS OPTIMISED. 3. REPRESENTATION OF THE REACTOR UNLOADING INCLUDED. 4. RAILS REMOVED FROM THE MAIN ROAD.			ZONE 1. Building for Ventilation Room is now limited for catering to the requirement of GIS.			ZONE 1. Building for Inert Gas System included. 2. Common Ventilation Room for Power House and GIS Building included. 3. Cable Trench shown for the CAT to Switchyard. 4. The Layout of the Transformer Cavern shall be part of shown in "Cross Section and Plan of Transformer Cavern - 1 200 00 20558. 5. Comments marked on Rev-01 incorporated.			REV. DATE ALTERED		SHT. No 01 NO. OF SHT. 04
ZONE 1. DETAILS OF THE REACTOR AND REACTOR CUM NGR AREA INCLUDED. 2. DISTANCE BETWEEN THE REACTORS OPTIMISED. 3. REPRESENTATION OF THE REACTOR UNLOADING INCLUDED. 4. RAILS REMOVED FROM THE MAIN ROAD.			ZONE 1. Building for Ventilation Room is now limited for catering to the requirement of GIS.			ZONE 1. Building for Inert Gas System included. 2. Common Ventilation Room for Power House and GIS Building included. 3. Cable Trench shown for the CAT to Switchyard. 4. The Layout of the Transformer Cavern shall be part of shown in "Cross Section and Plan of Transformer Cavern - 1 200 00 20558. 5. Comments marked on Rev-01 incorporated.			REV. DATE ALTERED		SIZE-A2

THE INFORMATION ON THIS DOCUMENT IS THE PROPERTY OF BHARAT HEAVY ELECTRICALS LIMITED. IT MUST NOT BE USED DIRECTLY OR INDIRECTLY IN ANY WAY DETRIMENTAL TO THE INTEREST OF THE COMPANY

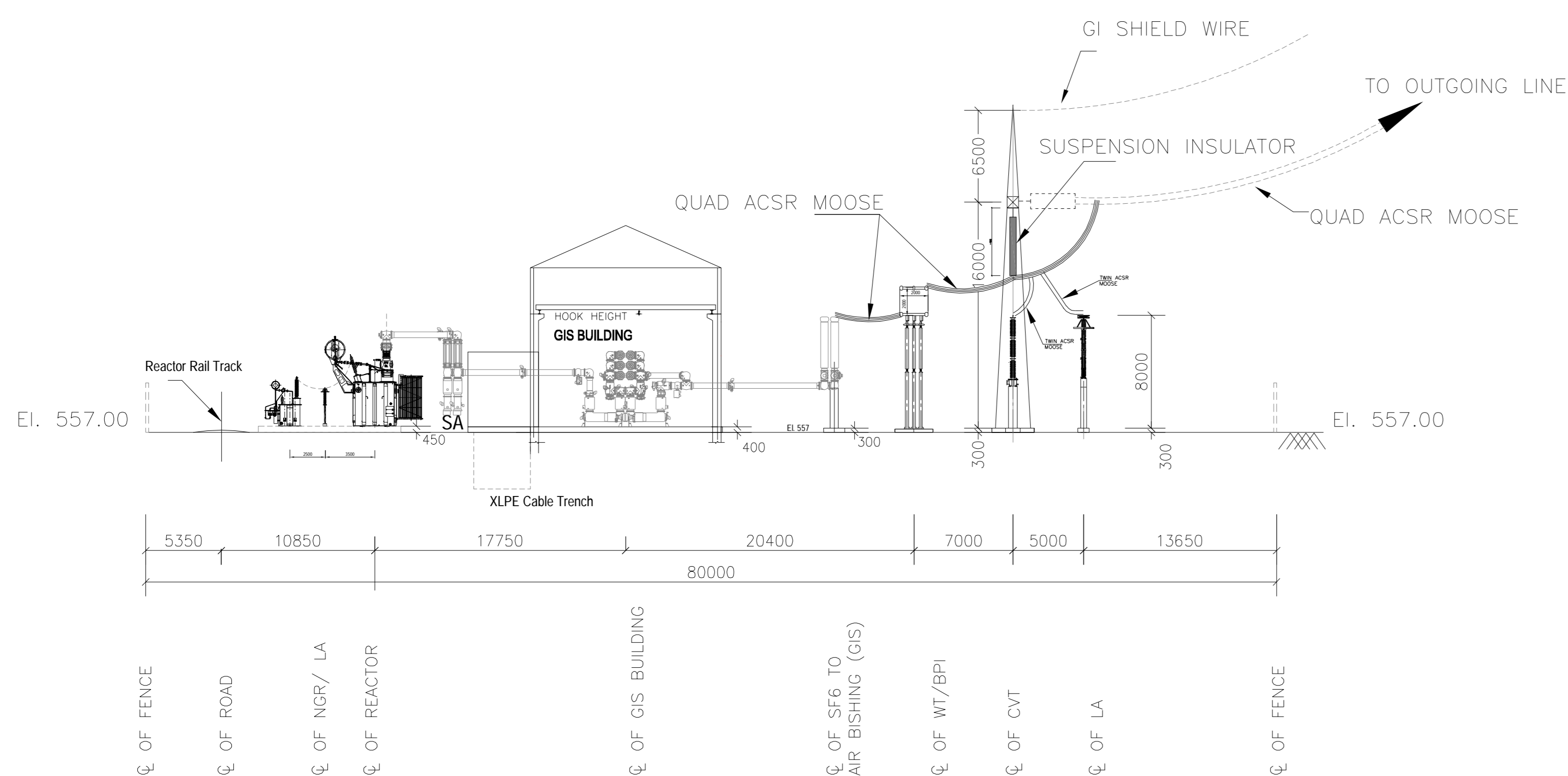

SECTION A-A

- ALL DIMENSIONS ARE IN MM. UNLESS OTHERWISE SPECIFIED.
- MINIMUM CLEARANCE TABLE
 - (a) PHASE TO PHASE = 4000 MM.
 - (b) PHASE TO EARTH = 3500 MM.
 - (c) SECTIONAL CLEARANCE = 6500 MM
- REMARK FOR 400KV GIS IN POTHEAD YARD: PLEASE REFER DRAWING # TB-405-317-10-02 (1HYG900079-2) 400KV GIS LAYOUT (PLAN, SECTION & ISOMETRIC VIEW) FOR RELATIVE SPACING & DIMENSIONS OF GIS ASSEMBLY, GAS INSULATED BUS DUCT, SF6 TO AIR BUSHING ETC. THIS DRAWING INDICATE REFERENCE AXIS OF GIS ASSEMBLY.
- LEVELS FOR SWITCHYARD ARE AS PER Revised Switchyard Layout - Sketch - Drg No. SJVN/ED/Arun-III/EM-2017-04
- ELEVATION OF SWITCHYARD AREA = 557.00 M.
- SYSTEM NOMINAL VOLTAGE = 400KV.
- SYSTEM HIGHEST VOLTAGE = 420KV.
- DOUBLE BUS-BAR SCHEME WITH BUS-COUPLER HAS BEEN ADOPTED IN GIS.
- CONDUCTOR FOR 400KV SYSTEM WILL BE QUAD/TWIN MOOSE.
- ALL STRUCTURE/CONDUCTOR HEIGHTS ARE ABOVE PLINTH LEVEL. PLINTH LEVEL - 300 MM ABOVE F.G.L.
- ALL FLEXIBLE CONNECTIONS ARE WITH QUAD MOOSE/TWIN ACSR MOOSE CONDUCTOR WITH 450 MM SPACING.
- LOCATION OF WAVE TRAPS ARE INDICATIVE ONLY AND THE EXACT LOCATION WILL BE BASED ON PLCC REQUIREMENT. THE FDN. DESIGN SHALL BE PROVIDED BY BHEL.
- GIS/BUS DUCT LAYOUT IS TENTATIVE AND SHALL BE FINALIZED AFTER VENDOR FINALIZATION OF GIS.
- SWITCHGEAR ROOM AND GIS BUILDING LAYOUT SHALL BE SUBMITTED SEPARATELY.
- THE SCOPE OF BHEL SHALL BE LIMITED TO POINT OF CONNECTION OF OUTGOING LINE AT THE DEAD END GANTRY.
- THE DETAIL OF THE CABLE TERMINATION ON GT AND CABLE SUPPORT SYSTEM SHALL BE ADDED IN SUCCESSIVE REVISIONS.
- ROADS, FENCE AND GATE IS NOT IN BHEL'S SCOPE.
- OUTGOING STRINGING OF LINE CONDUCTOR & SHIELD WIRE ARE NOT IN BHEL SCOPE BUT CONNECTION OF EQUIPMENT TOWARDS LINE SIDE SHALL BE DONE BY BHEL..
- CONSTRUCTION OF FIRE RESISTANT WALL BETWEEN 400KV REACTOR UNITS ARE NOT IN BHEL SCOPE.
- PHASE SEQUENCE IS INDICATIVE & IT SHALL BE VERIFIED AT SITE DURING EXECUTION.
- THE DIMENSION OF THE XLPE CABLE TRENCH IS TENTATIVE AND SHALL BE FINALISED IN LINE WITH THE CABLE LAYING PHILOSOPY OF THE EHV XLPE CABLE SUPPLIER.
- THE SWITCHGEAR BUILDING LAYOUT SHALL BE FURNISHED AS A SEPARATE DRAWING.
- DETAILS OF CABLE TRENCH - ROAD CROSSING ARRANGEMENT SHALL BE SHOWN IN CABLE TRENCH LAYOUT.
- FOUNDATION WORKS TO BE UNDERTAKEN BY EMPLOYER.HOWEVER,BHEL SHALL BE RESPONSIBLE FOR DESIGNING AND SUPPLYING DRAWINGS AND MATERIALS SUCH AS INSERT,EMBEDMENTS,BOLTS FOR FOUNDATION.
- REACTOR, UNLOADING AND HANDLING AT SITE SHALL BE ARRANGED BY BHEL.
- REFER SOAK PIT DESIGN FOR THE DETAILS OF THE SOAK PIT.
- REFER TO THE CONCEPTUAL DRAWING OF THE CONTROL ROOM BUILDING FOR THE CONTROL ROOM BUILDING DETAIL.
- SCOPE: GRAVEL AND THE GRATING IN THE REACTOR PIT SHALL BE IN THE SUPPLY SCOPE OF THE END CUSTOMER.
- THE ACTUAL COORDINATES OF THE DG AND THE BOT SHALL BE FINALISED BY THE END CUSTOMER.
- LOCATION OF WORKSHOP & 33KV T/L IS INDICATIVE. EXACT LOCATION TO BE FINALISED BY SAPDC AS PER SITE CONDITION.

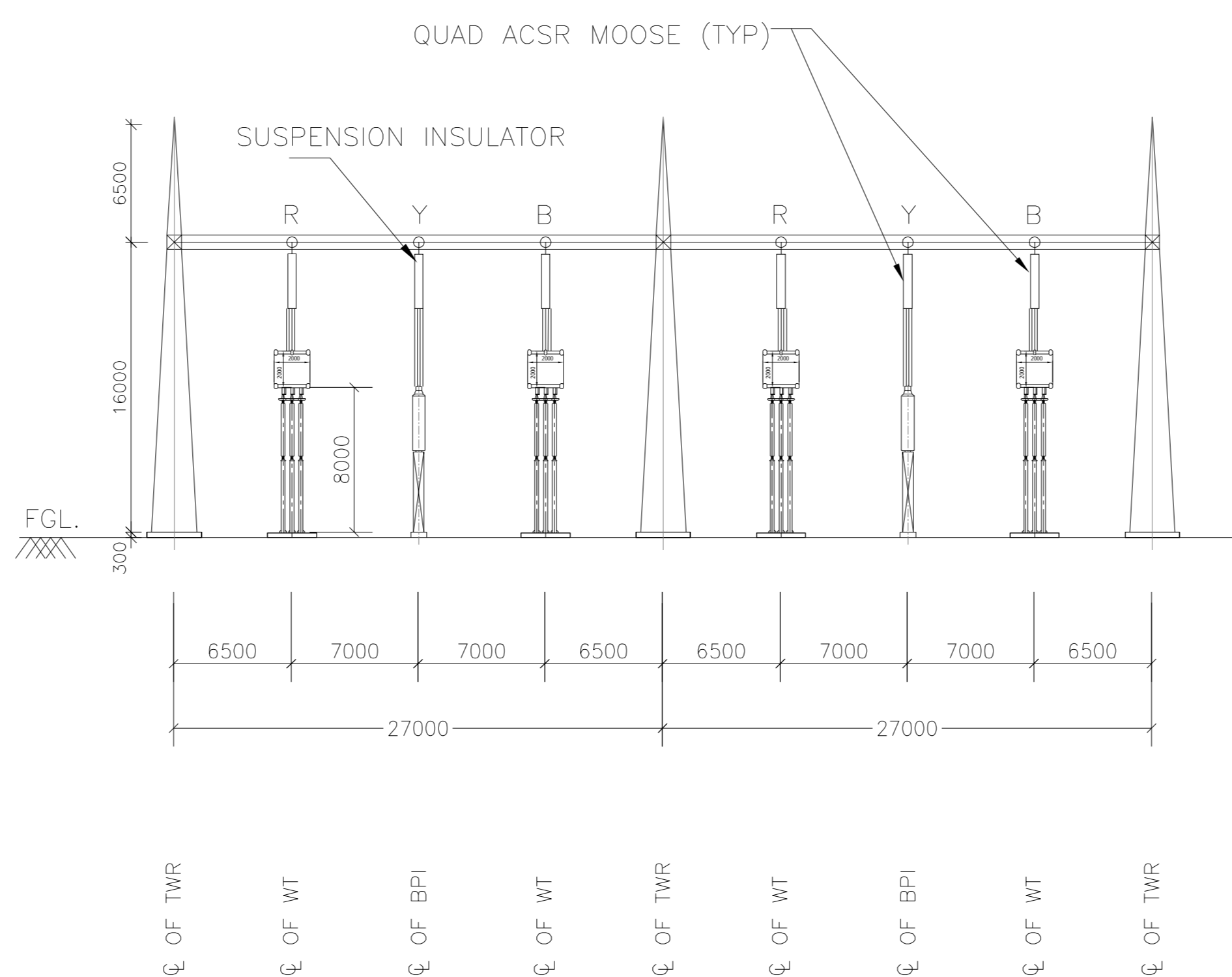

SECTION B-B

MINIMUM CLEARANCE TABLE		400KV
PHASE TO PHASE (PP) (mm)		4000
PHASE TO EARTH (PE) (mm)		3500
SECTION CLEARANCE (SC) (mm)		6500
HEIGHT OF CONDUCTOR CENTRE LINE OF FIRST LEVEL (MIN.) MM. (FROM PLINTH LEVEL)		8000
GROUND CLEARANCE TO NEAREST PART NOT AT EARTH POTENTIAL OF AN INSULATOR SUPPORTING LIVE CONDUCTOR		2550
CREEPAGE DISTANCE (mm/kV)		25

CONDUCTOR SIZE DETAILS		
EQUIPMENT INTERCONNECTION	400 KV	QUAD 'MOOSE' CONDUCTOR
CONNECTION DROPS	400 KV	QUAD 'MOOSE' CONDUCTOR TWIN 'MOOSE' CONDUCTOR ON CVT AND SURGE ARRESTER

BILL OF QUANTITY OUTDOOR EQUIPMENT:-

S.NO.	DESCRIPTION	SYMBOL	QUANTITY (NOS.)
1	420 kV INDOOR GIS		01
2	420 KV, 1-ph SF6 TO AIR BUSHING		06
3	420kv, 1-ph CVT		06
4	336kv, 1-ph SURGE ARRESTER		06
5	420kv, 8 KN, 1-ph, BUS POST INSULATOR		02
6	WAVE TRAP		04
7	400KV,80MVAR REACTOR (BHEL MAKE)		03
8	NGR (BHEL MAKE)		02
9	120kv, 1-ph SURGE ARRESTER FOR NGR		2

CO-ORDINATES & ELEVATIONS OF IMPORTANT POINTS

CO-ORDINATES & ELEVATIONS OF IMPORTANT POINTS						
S.No.	DESCRIPTION	POINTS	EASTINGS	NORTHINGS	INVERT ELEVATION	REMARKS
1.	SWITCH YARD	SY1	519456.419	3043702.499	557.00	FINISHED LEVEL
		SY2	519380.269	3043677.981	557.00	-DO-
		SY3	519505.452	3043550.197	557.00	-DO-
		SY4	519443.580	3043530.277	557.00	-DO-

SCOPE OF CUSTOMER

ITEM NO.	DESCRIPTION	QTY.
01	GRATING IN LINE REACTOR AREA	2 LOT
02	GRATING IN BUS REACTOR AREA	1 LOT
03	PULLING BLOCK	6 NOS
04	FENCE	1 LOT
05	GRAVEL	1 LOT

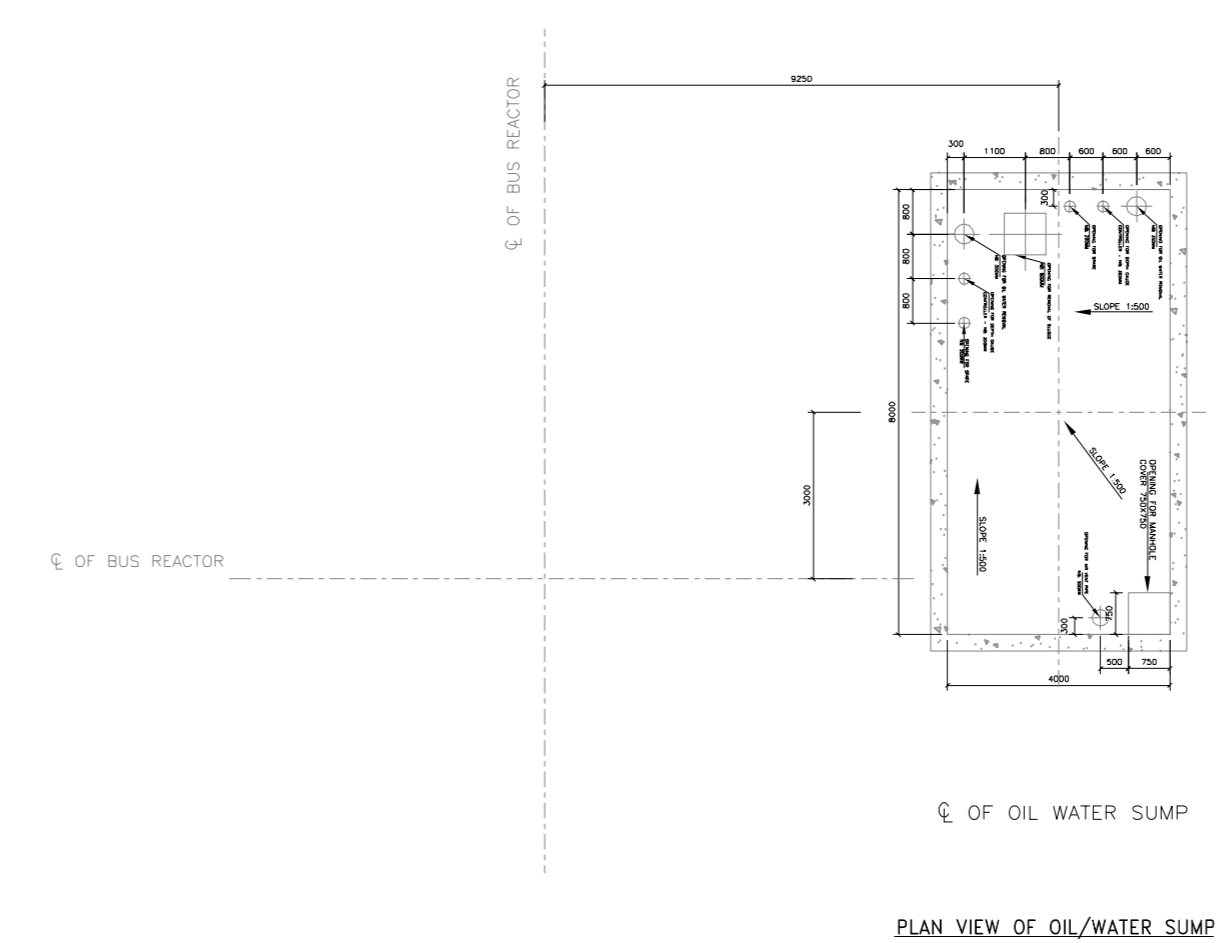

SYSTEM PARAMETERS	
NOTES:-	400KV SWITCHYARD
1. RATED VOLTAGE	: 400kv
2. HIGHEST SYSTEM VOLTAGE	: 420KV
3. SYSTEM VOLTAGE VARIATION	: -5% to +5%
4. RATED FREQUENCY	: 50 Hz, ±3%
5. INSULATION LEVELS FOR 400KV CIRCUIT BREAKERS AND DISCONNECTING SWITCHES	
5A. RATED ONE MINUTE POWER FREQUENCY WITHSTAND VOLTAGE BETWEEN LIVE TERMINAL AND EARTH: 630 KV RMS FOR POTHEAD YARD EQUIPMENTS	: 650 KV RMS (GIS)
5B. RATED LIGHTNING IMPULSE WITHSTAND VOLTAGE	A) ± 1425 KVP BETWEEN LIVE TERMINALS AND EARTH. B) ± 1665 KVP IMPULSE ON ONE TERMINAL AND OTHER TERMINAL EARTHED (ACROSS ISOLATING DISTANCE).
5C. RATED SWITCHING IMPULSE WITHSTAND VOLTAGE	: 1050 KVP (PHASE TO EARTH) 1425 KVP (PHASE TO PHASE)
6. RATED SHORT TIME WITHSTAND CURRENT CAPACITY	: 50 KA/SEC. RMS
7. SYSTEM NEUTRAL EARTHING	: EFFECTIVELY EARTHED
8. AC AUX. SUPPLY	: 415V, 3PH, 4 WIRE (+10% TO -10%) 240V, 1PH, 2 WIRE (+10% TO -10%)
9. CONTROL VOLTAGE	: 220V DC, 2 WIRE, +10% TO -20%
11. GIS BUS CONFIGURATION	: DOUBLE BUSBAR, 400 kv, 2500A, 50KA FOR 1S
12. ALL EQUIPMENT SHALL BE RATED FOR 50 DEG CENTIGRADE AMBIENT AND OUTDOOR INSTALLATION.	

LEGEND TABLE:-

	400kv TENSION INSULATOR NOT IN BHEL'S SCOPE
	QUAD MOOSE ACSR CONDUCTOR
	TWIN MOOSE ACSR
	SHIELD WIRE
	FENCE (NOT IN SCOPE OF BHEL)
	CONNECTION TO QUAD ACSR MOOSE CONDUCTOR
	PROPOSED SCOPE
	EXISTING/FUTURE SCOPE (NOT IN TBG SCOPE)
	GIB (GAS INSULATED BUS DUCT)
	TOWER WITH PEAK
	LM (LIGHTNING MAST)
	ENTRY GATE (NOT IN BHEL SCOPE)

REV.	DATE	ALTERED	REV.	DATE	ALTERED	REV.	DATE	ALTERED	ADDITIONAL INFORMATION :	PROJECT:					
07	18/11/21	CHD/APPD	06	22/06/21	CHD/APPD	05	28/05/21	CHD/APPD	WO NO. :	ARUN-3 HYDRO ELECTRIC PROJECT (NEPAL) (4 x 225 MW)					
ZONE	CURRENT REVISION INCORPORATES CHANGES AS PER EMAIL DATED 14 JUNE 2021 AND 5TH JULY 2021 FROM M/S SJVN		ZONE	CURRENT REVISION INCORPORATES CHANGES AS PER EMAIL DATED 14 JUNE 2021 FROM M/S SJVN		ZONE	CURRENT REVISION INCORPORATES SOAK PIT AS PER SOAK PIT DOCUMENT REV-04 (TB-405-316-018)		STATUS OF DRAWING :	CUSTOMER: SJVN ARUN-3 POWER DEVELOPMENT COMPANY PVT. LTD. (SAPDC LTD.)					
ZONE			ZONE			ZONE			DISTRIBUTION OF PRINTS :	CONSULTANT: SJVN LTD. (A JOINT VENTURE OF GOVT OF INDIA AND GOVT OF HP)					
REV.	DATE	ALTERED	REV.	DATE	ALTERED	REV.	DATE	ALTERED	REV.	DATE	ALTERED	NAME	SIGN.	DATE	
04	20/10/20	CHD/APPD	03	10/03/20	CHD/APPD	02	07/06/19	CHD/APPD	01	30/03/19	CHD/APPD	BHARAT HEAVY ELECTRICALS LTD.		30/10/2018	
ZONE	1. DETAILS OF THE REACTOR AND REACTOR CUM NGR AREA INCLUDED. 2. DISTANCE BETWEEN THE REACTORS OPTIMISED. 3. REPRESENTATION OF THE REACTOR UNLOADING INCLUDED.		ZONE	1. Building for Ventilation Room is now limited for catering to the requirement of GIS.		ZONE	1. Building for Inert Gas System included. 2. Common Ventilation Room for Power House and GIS Building included. 3. Cable Trench shown for the CAT to Switchyard. 4. The Layout of the Transformer Cavern shall be part of shown in "Cross Section and Plan of Transformer Cavern - 1 200 00 20558. 5. Comments marked on Rev-01 incorporated.		ZONE	Revised Switchyard Layout - Sketch - Drg No. SJVN/ED/Arun-III/EM-2017-04		DRN. PK		30/10/2018	
											APPD. SKS		30/10/2018		
											DEPT. TBG		SCALE	CARD	
											CODE	NTS	CODE		
											TITLE		DRG.NO.	REV.	
											ELECTRICAL LAYOUT PLAN AND SECTION OF 4x225MW OF ARUN-3 HEP		TB-3-405-316-001	07	
											SHT. No	02	NO. OF SHT.	04	

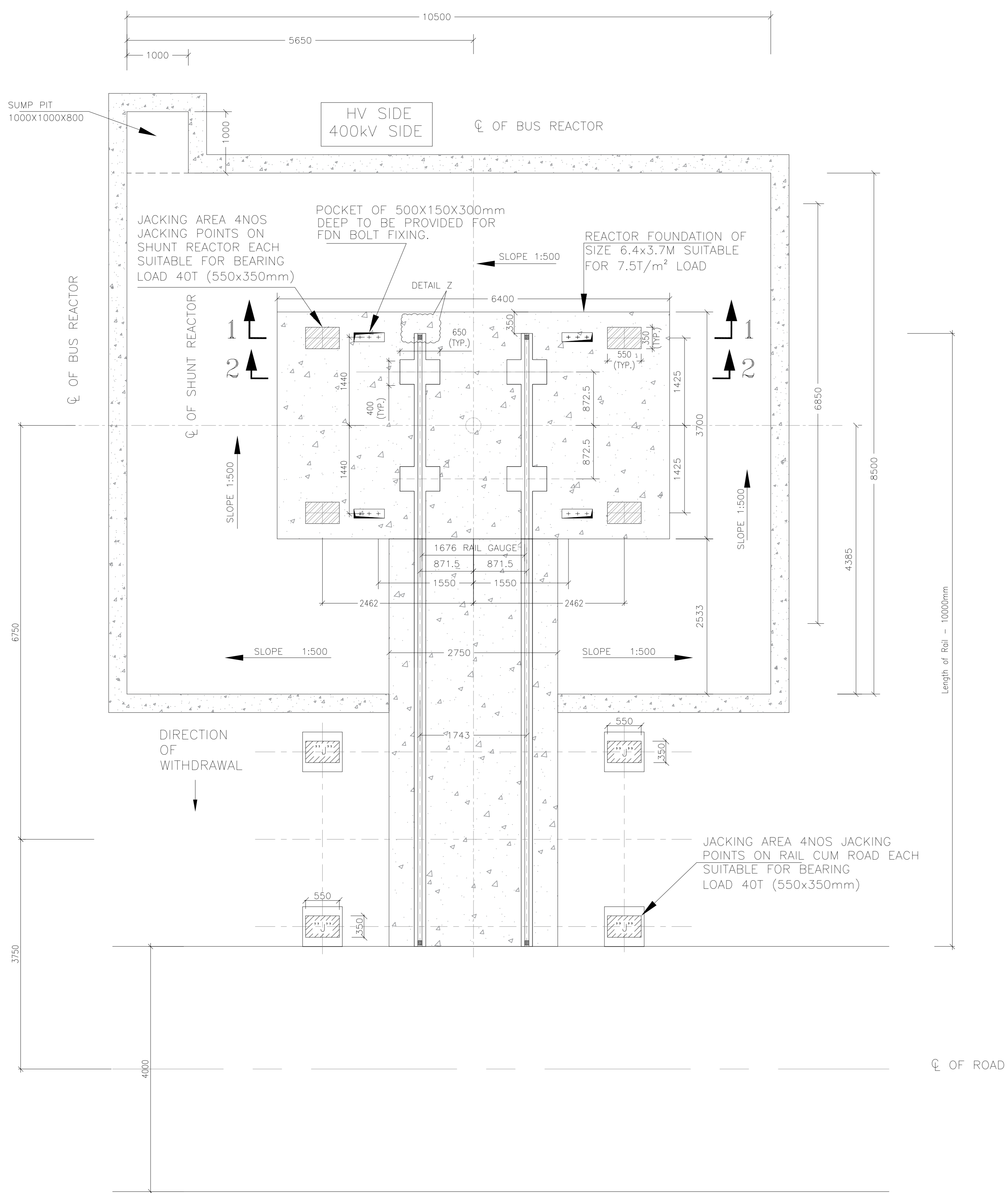

PLAN VIEW OF SHUNT REACTOR AREA(TYP)

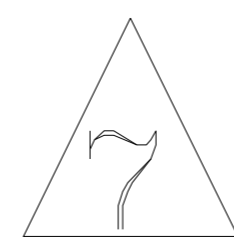
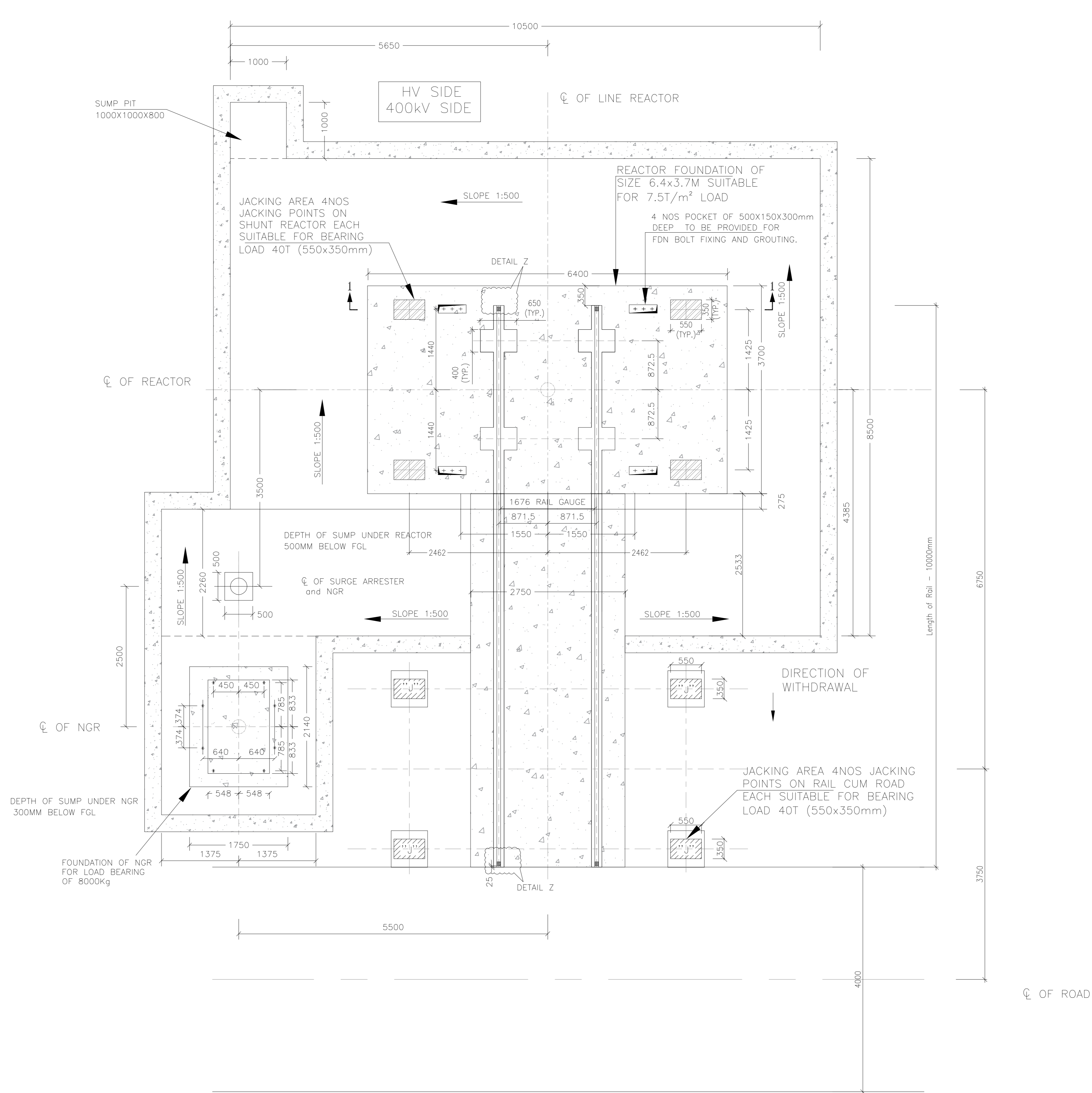

PLAN VIEW OF LINE REACTOR WITH NGR AREA (TYP)

PROJECT: ARUN-3 HYDRO ELECTRIC PROJECT (NEPAL)
(4 x 225 MW)

CUSTOMER: SJVN ARUN-3 POWER DEVELOPMENT
COMPANY PVT. LTD. (SAPDC LTD.)

CONSULTANT: SJVN LTD.
(A JOINT VENTURE OF GOVT OF INDIA AND GOVT OF HP)

ADDITIONAL INFORMATION :
WO NO. :

STATUS OF DRAWING :

DISTRIBUTION OF PRINTS :

NAME	SIGN.	DATE
DRN. PK		30/10/2018
CHD. Vyom/VK		30/10/2018
APPD. SKS		30/10/2018

DEPT. TBG CODE	SCALE NTS	CARD CODE
----------------	-----------	-----------

TITLE ELECTRICAL LAYOUT PLAN AND SECTION OF 4x225MW OF ARUN-3 HEP	DRG. NO. TB-3-405-316-001	REV. 07
SHT. No 03	NO. OF SHT. 04	

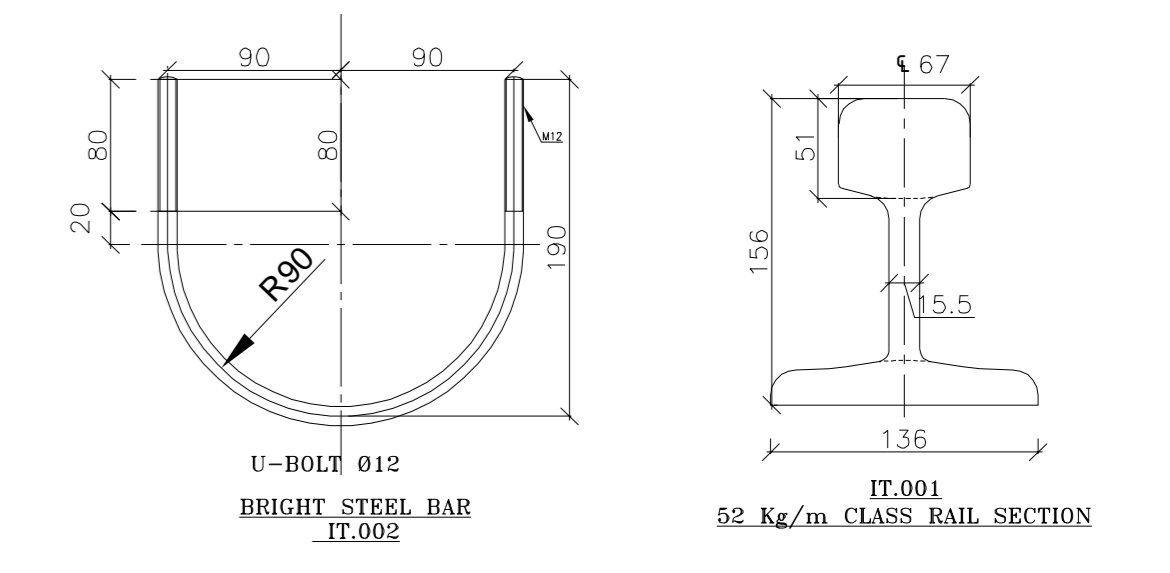
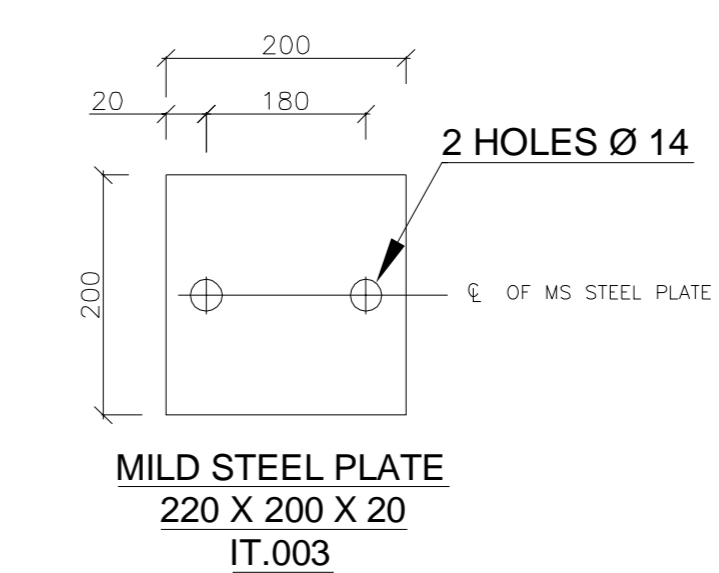
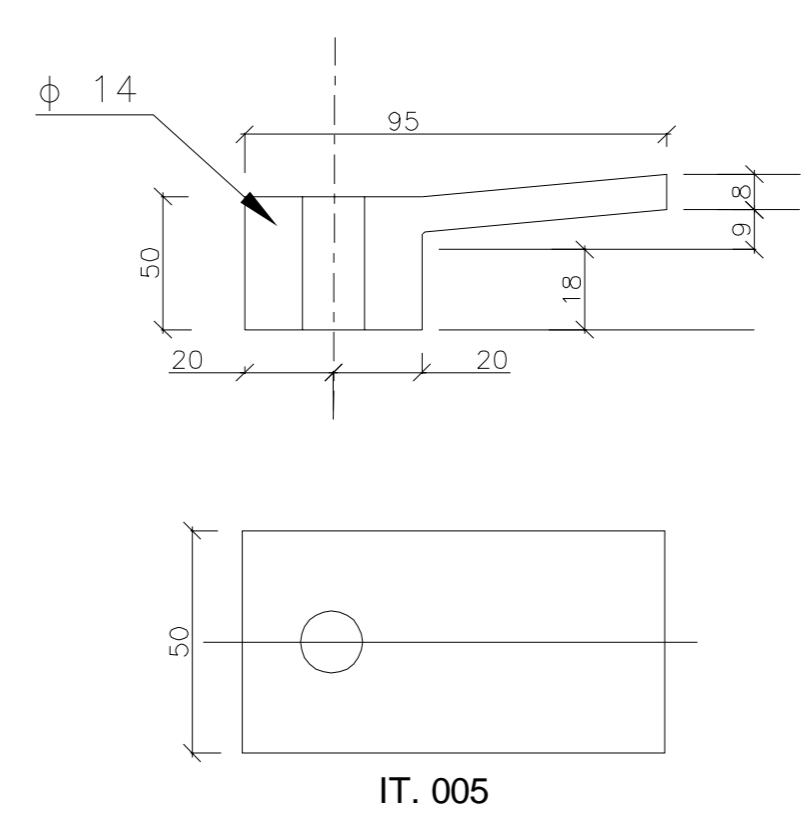
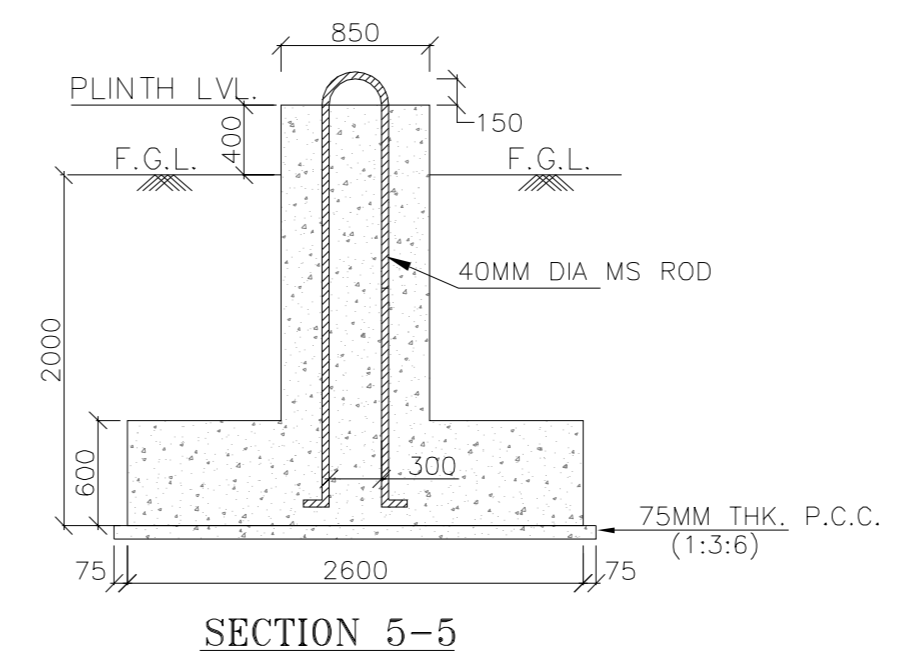
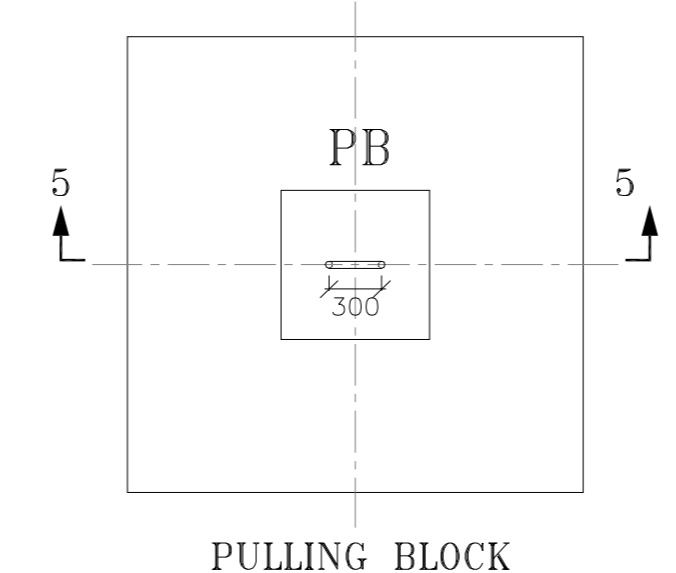
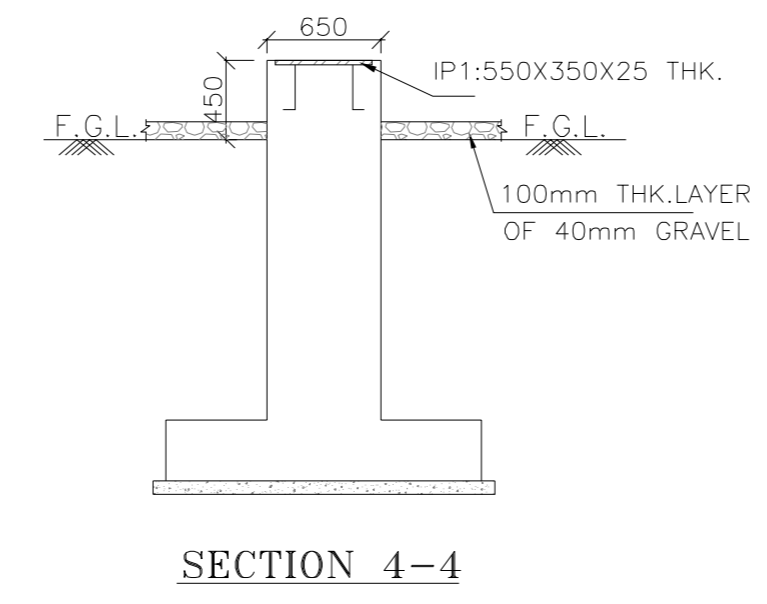
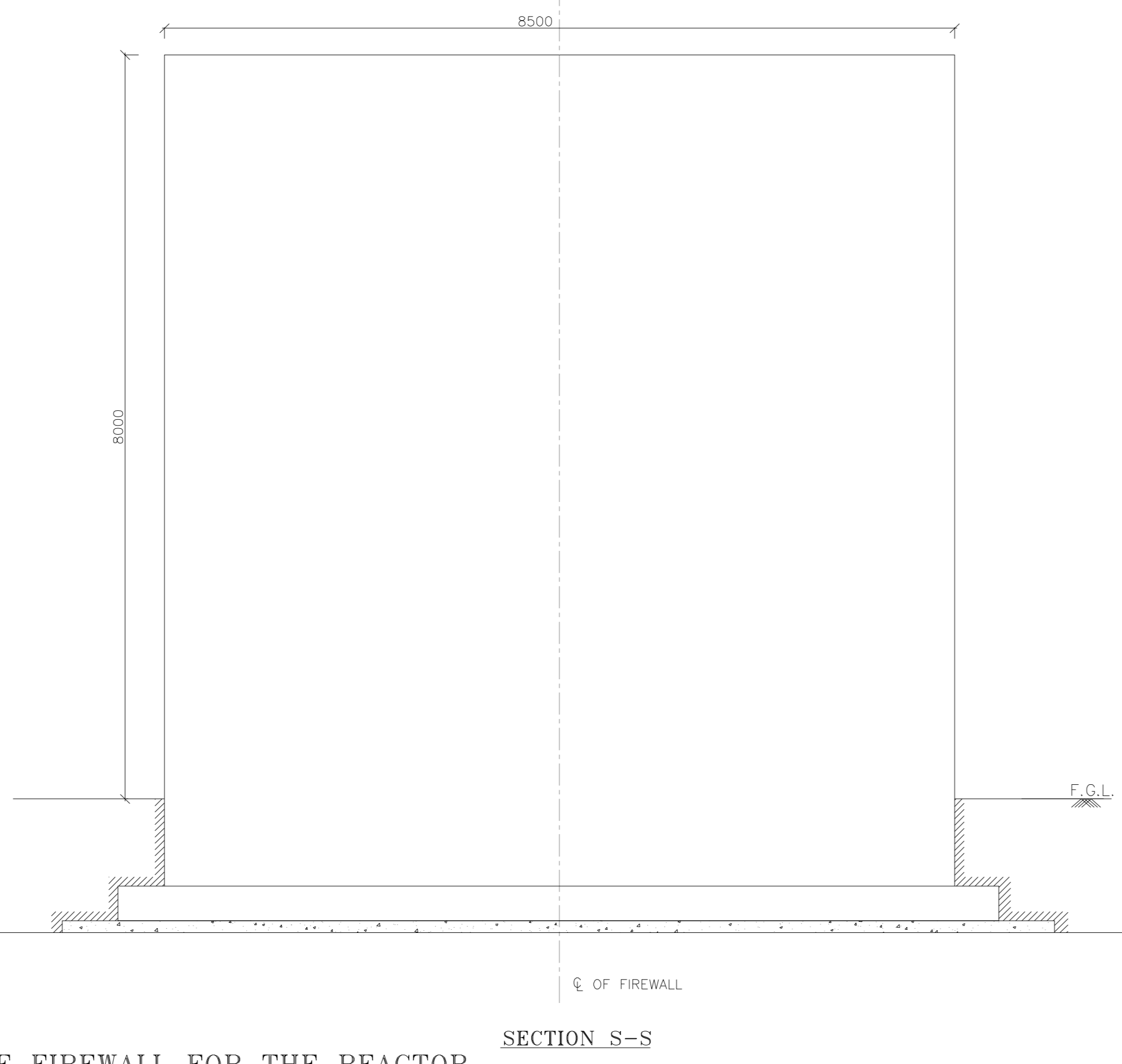
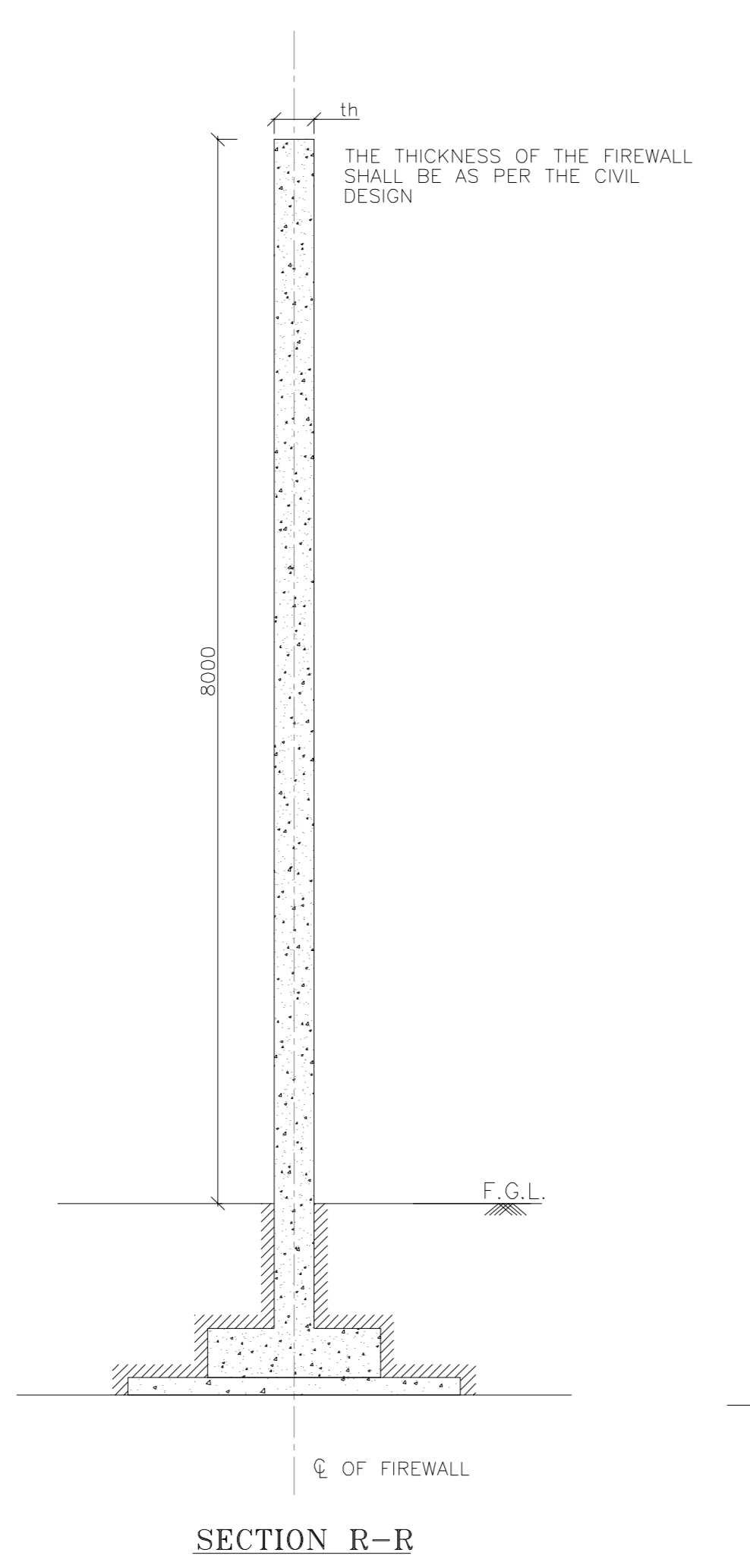
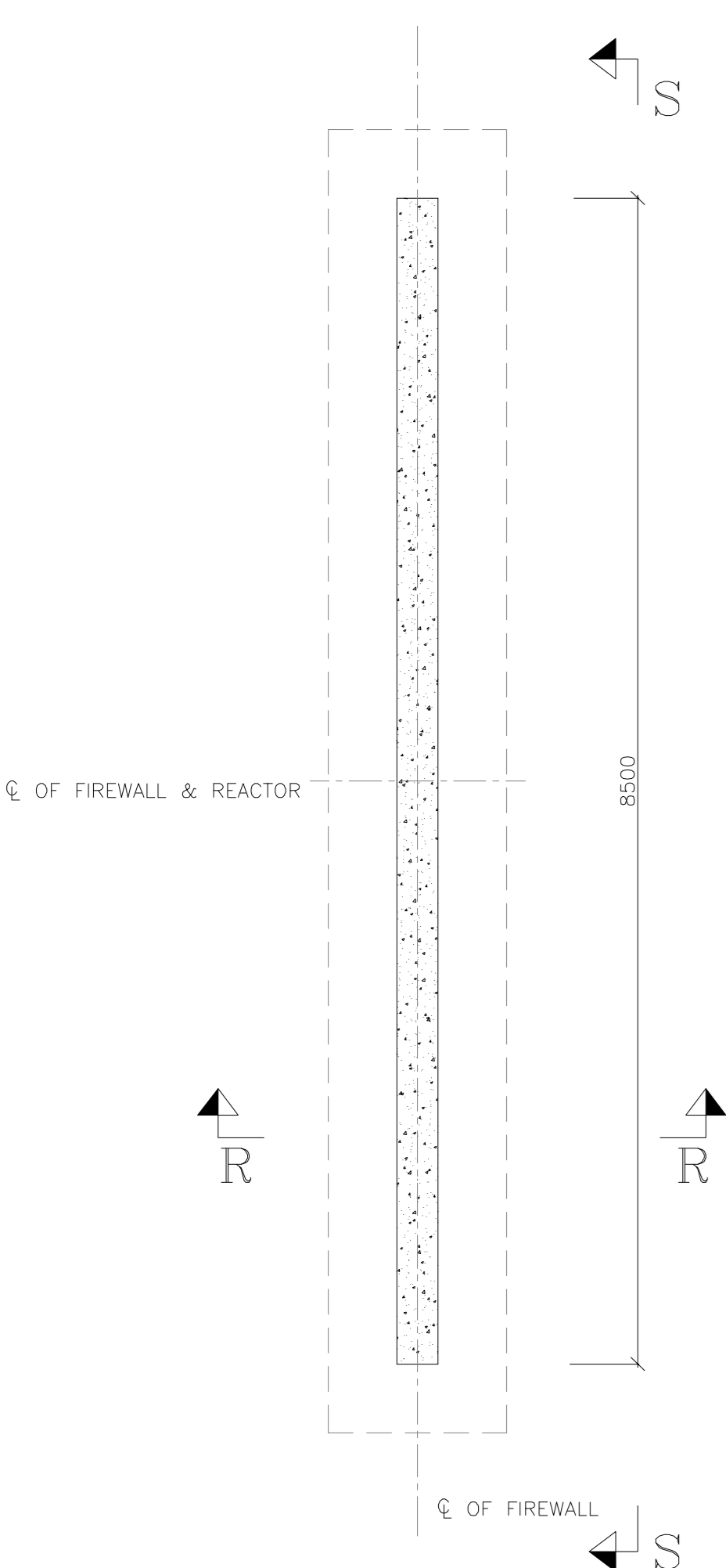
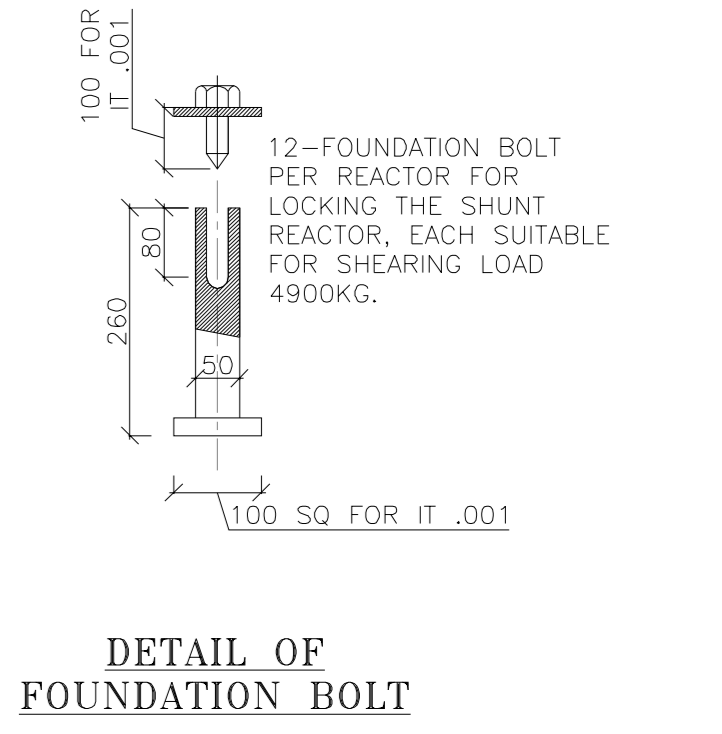
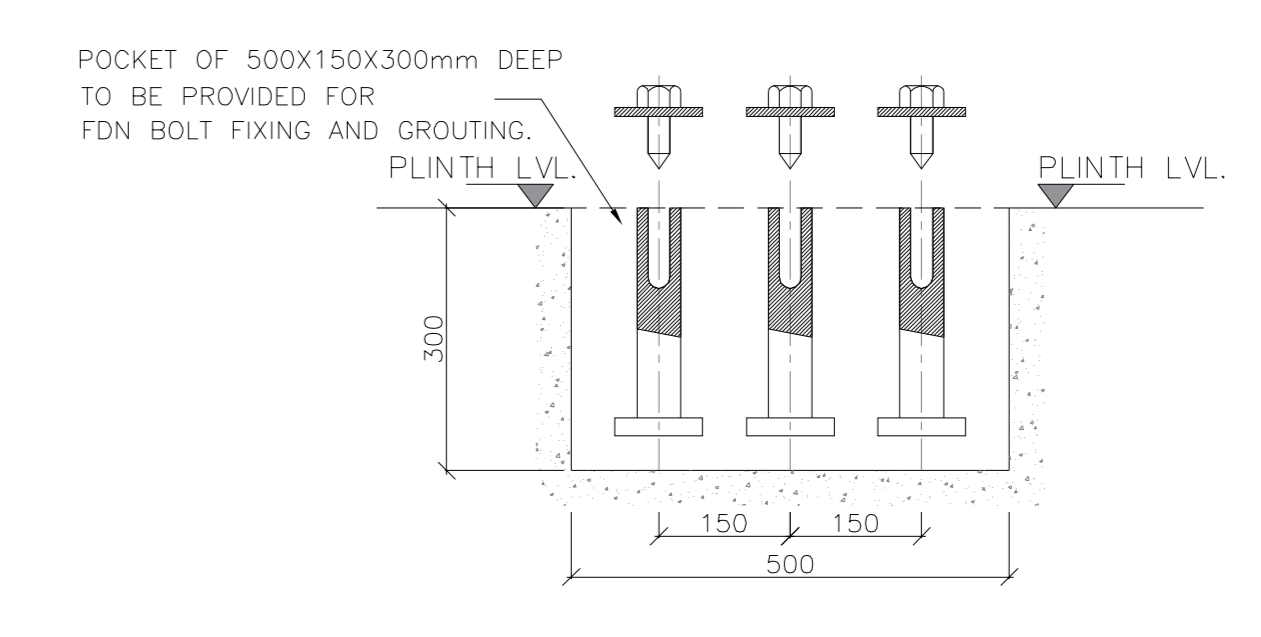
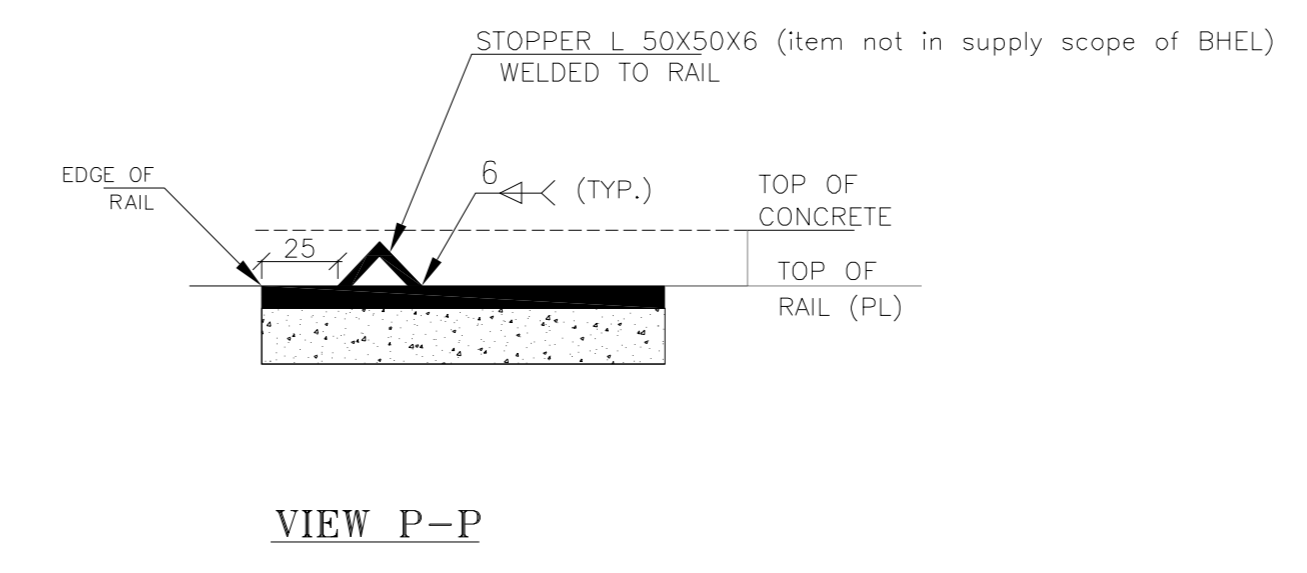
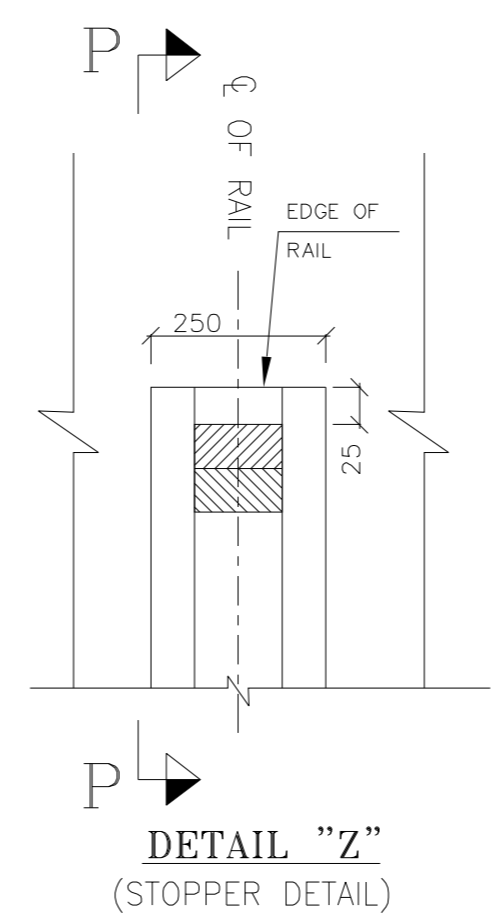
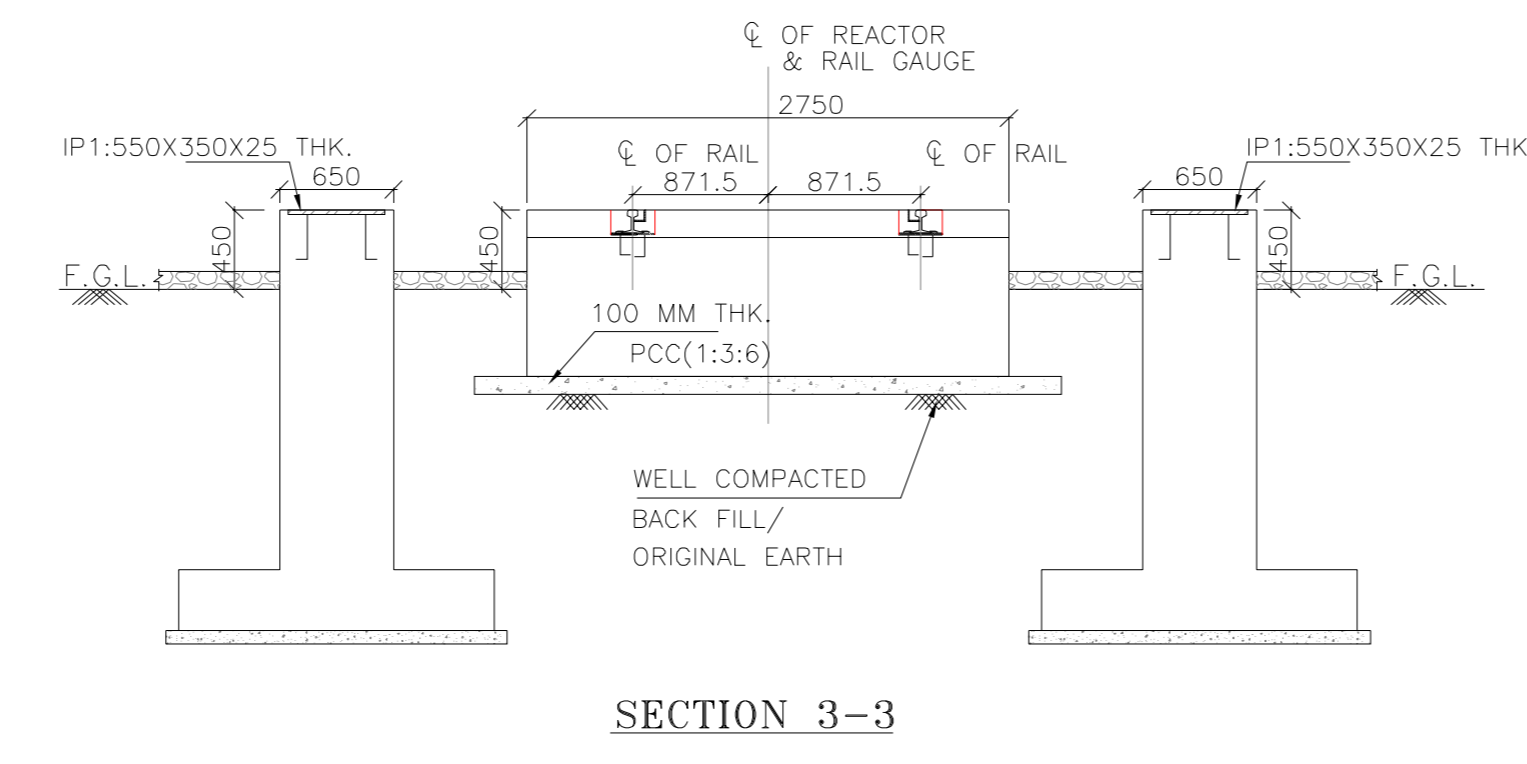
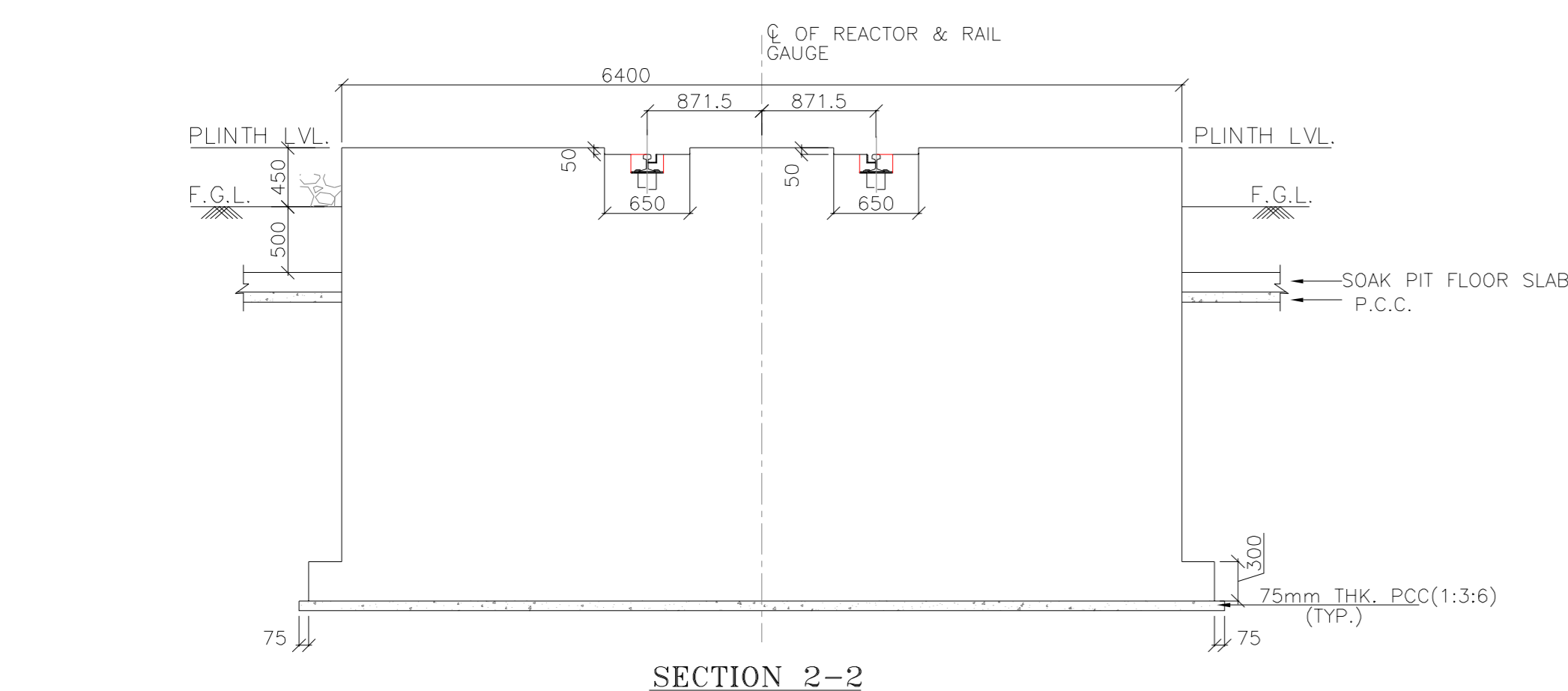
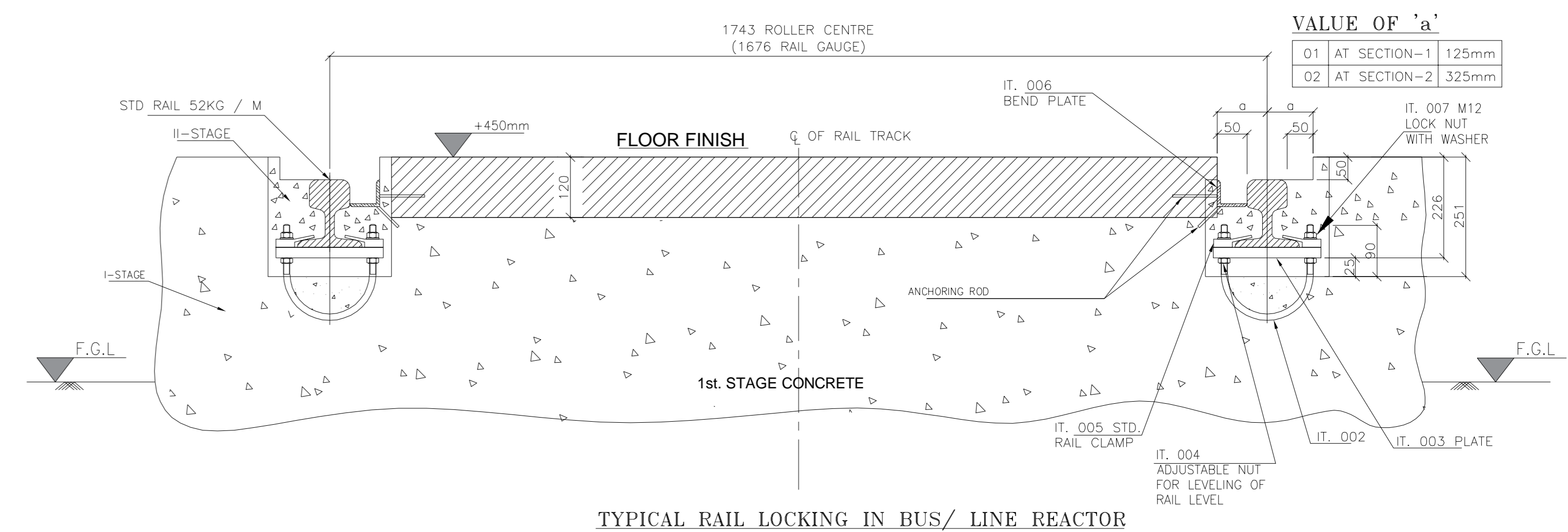
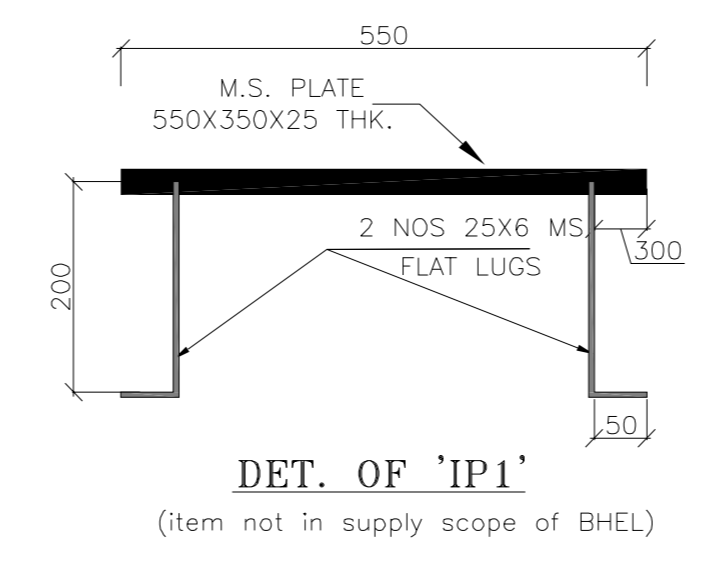
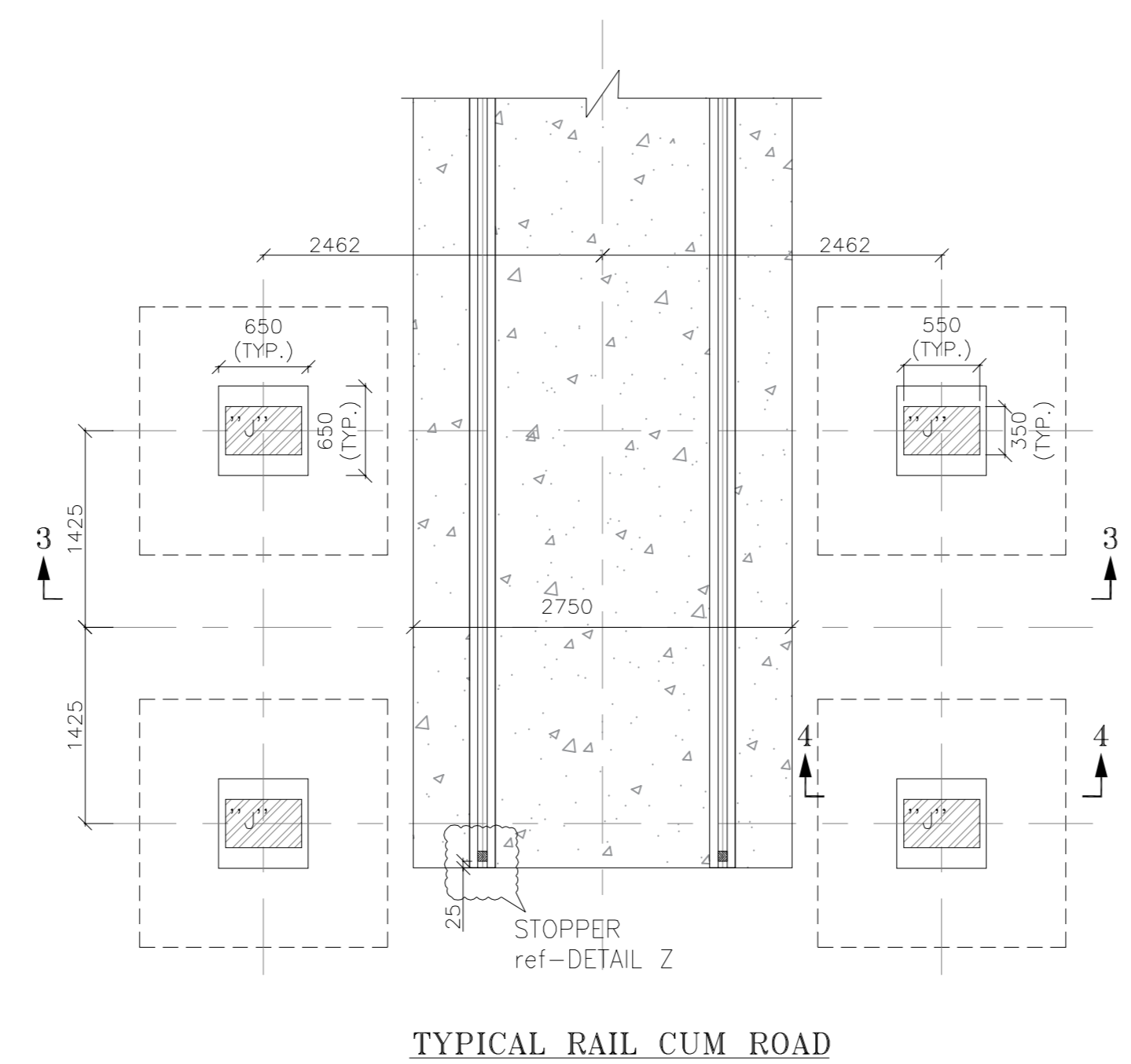
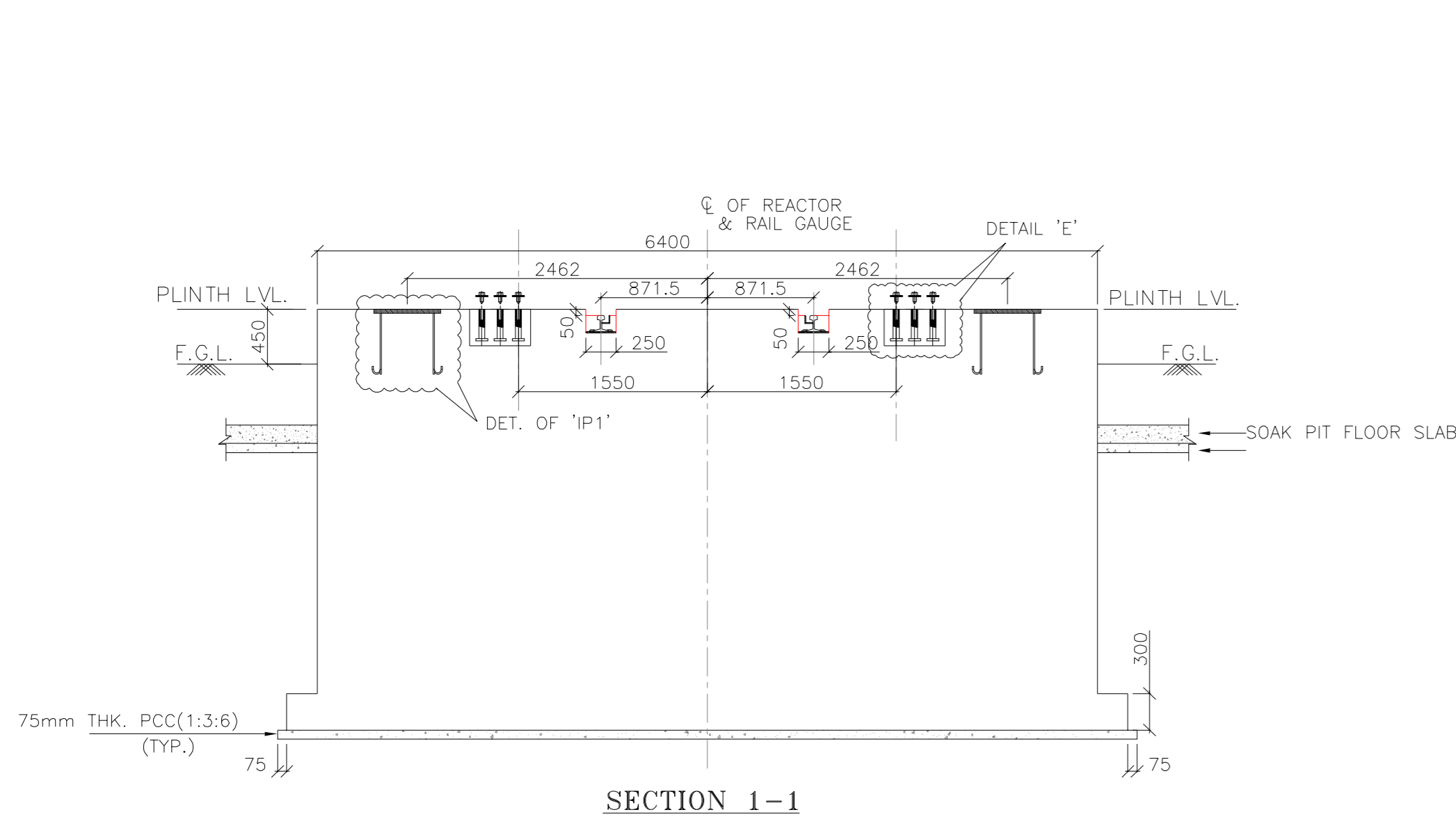

TABLE-A (BOM FOR RAIL FIXING ITEM) SCOPE OF BHEL-BHOPAL.

ITEM NO.	DESCRIPTION	QTY.
01	RAIL	60 METER
02	U BOLT FOR RAIL FIXING	124 NOS.
03	PLATE MS (220 X 200 X 20 MM)	124 NOS.
04	ADJUSTABLE NUT M12	248 NOS.
05	RAIL CLAMP	248 NOS.
06	BEND PLATE WITH ANCHORED ROD (50 X 50, 5mm)	62 METER
07	LOCK NUT M12 WITH WASHER	248 NOS.

PROJECT: ARUN-3 HYDRO ELECTRIC PROJECT (NEPAL)
(4 x 225 MW)

CUSTOMER: SJVN ARUN-3 POWER DEVELOPMENT COMPANY PVT. LTD. (SAPDC LTD.)

CONSULTANT: SJVN LTD.
(A JOINT VENTURE OF GOVT OF INDIA AND GOVT OF HP)

ADDITIONAL INFORMATION : WO NO. :		NAME	SIGN.	DATE
STATUS OF DRAWING :		DRN. PK		30/10/2018
DISTRIBUTION OF PRINTS :		CHD. Vyom/VK		30/10/2018
	DEPT. TBG	APPD. SKS		30/10/2018
	CODE	SCALE NTS	CARD CODE	
	TITLE	DRG. NO.		REV.
	ELECTRICAL LAYOUT PLAN AND SECTION OF 4x225MW OF ARUN-3 HEP	TB-3-405-316-001		07
		SHT. No 04	NO. OF SHT. 04	

THE INFORMATION ON THIS DOCUMENT IS THE PROPERTY OF BHARAT HEAVY ELECTRICALS LIMITED. IT MUST NOT BE USED DIRECTLY OR INDIRECTLY IN ANY WAY DETRIMENTAL TO THE INTEREST OF THE COMPANY

DRG. NO.

6

5

4

3

2

1

F
E
D
C
B
A

F
E
D
C
B
A

OTHER TECHNICAL REQUIREMENTS AS PER BHEL'S STANDARD SPECIFICATION

11.	SPEED REGULATION	BY ADJUSTING FREQUENCY USING THYRISTORS i.e rectifier bridge & Inverter
10.	AMBIENT TEMPERATURE	40 DEGREE CELCIUS
9.	CLASS	M5
8.	DUTY	INDOOR DUTY
7.	GIRDER	PLATE BOX CONSTRUCTION
6.	OPERATION	RRC + PENDANT
5.	BRAKES	1 NO DCEM + 1 NO EHT FOR EACH HOIST, LT & CT MOTIONS
4.	WIRE ROPE	EXTRA FLEXIBLE PLOUGH STEEL ALLOY STEEL. FOS = 6 MIN
3.	LT SPEED/CREEP SPEED	10/0.5 M/Min
2.	CT SPEED/CREEP SPEED	3/0.15 M/Min
1.	MH HOISTING/CREEP SPEED	3/0.15 M/Min
SL NO.	DESIGN STANDARD	IS 3177 & IS 807.
	TECHNICAL SPECIFICATION	

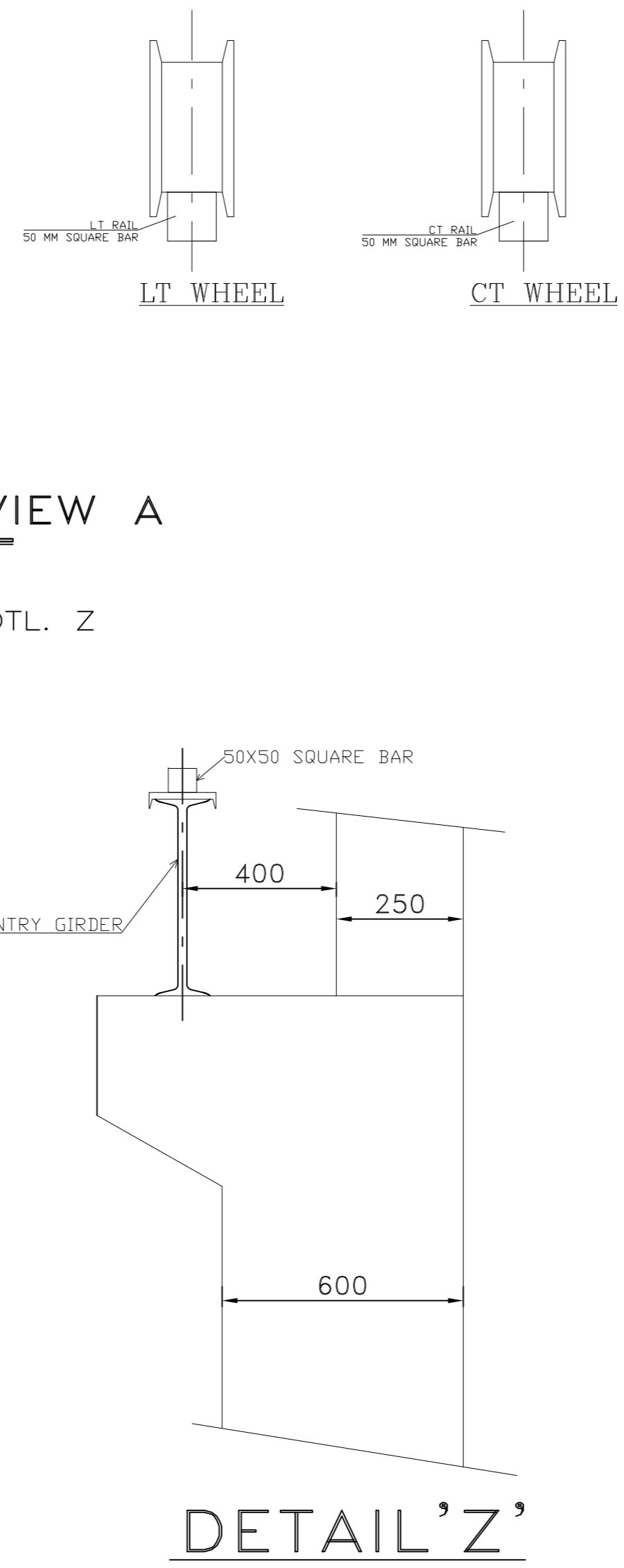
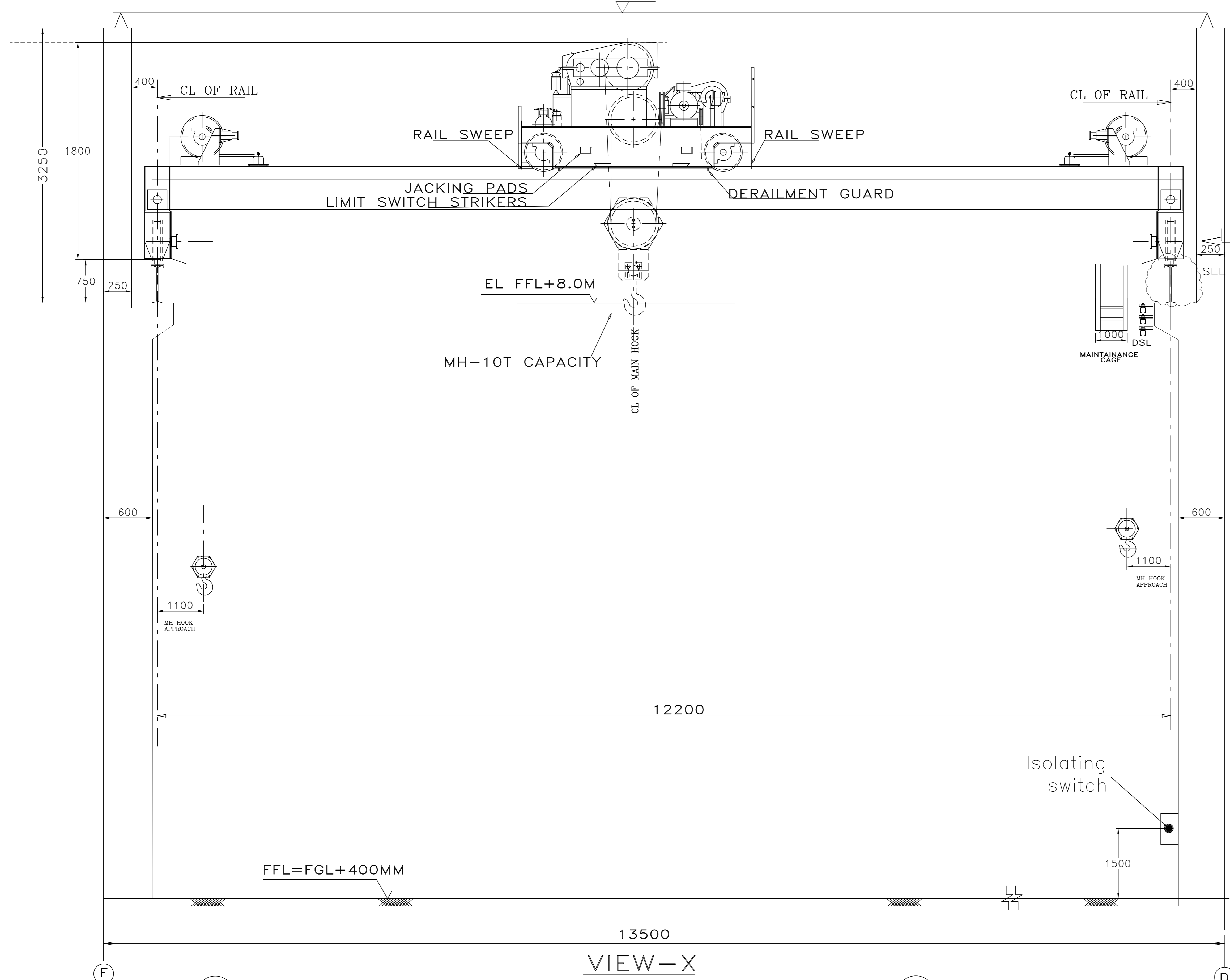

CRANE WEIGHT INCLUDING TROLLEY WEIGHT- 17 TONS

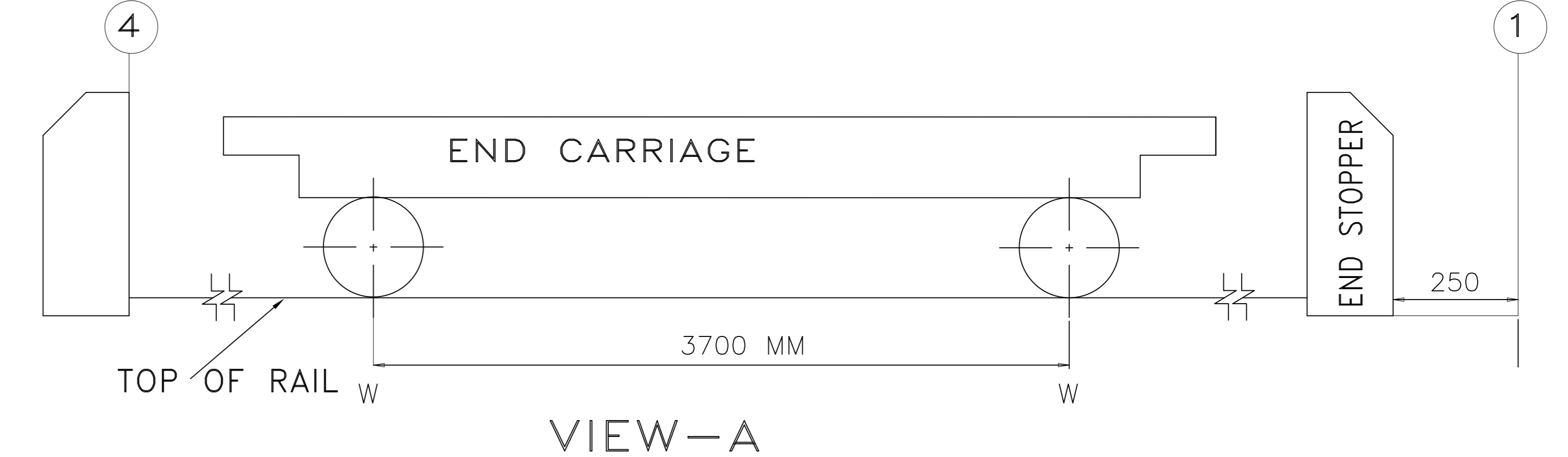

NOTES

- 1) DRAWING IS NOT TO THE SCALE.
- 2) ALL DIMENSIONS ARE IN MM.
- 3) THE CRANE PARAMETERS i.e HOOK APPROACHES, WHEEL LOAD, WEIGHTS ETC ARE ON PRELIMINARY BASIS AND SUBJECT TO MINOR VARIATION AS PER ACTUAL MANUFACTURER'S DESIGN REFERENCE DRGS
- 4) GANTRY GIRDER/ RUNWAY BEAM IN CUSTOMER CIVIL SCOPE.
- 5) 50MM SQUARE BAR IN BHEL SCOPE

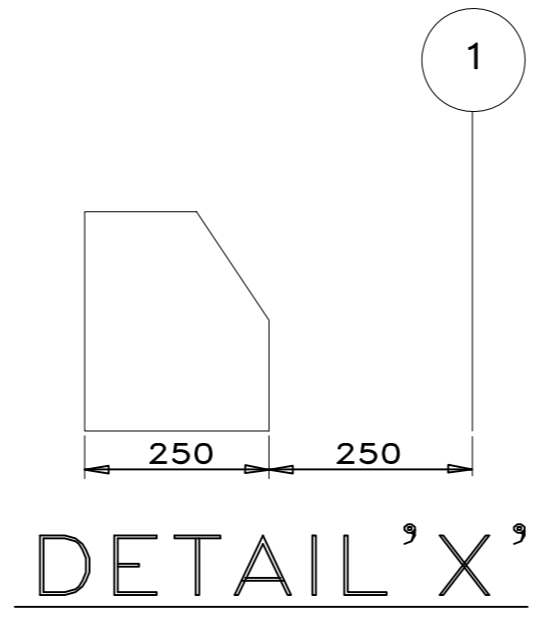
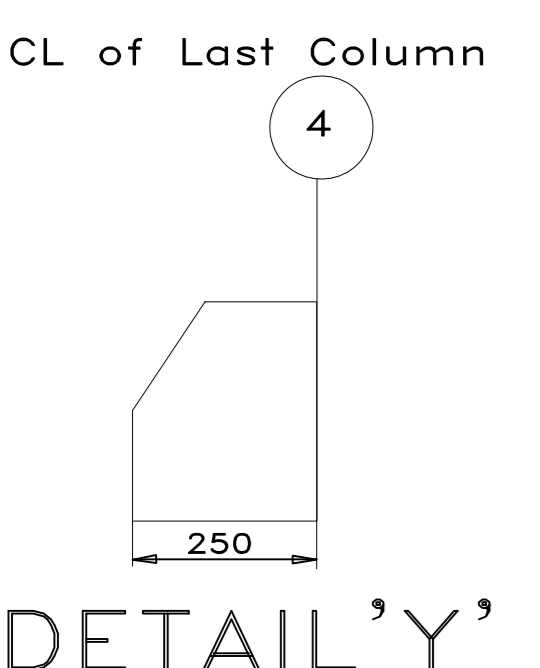
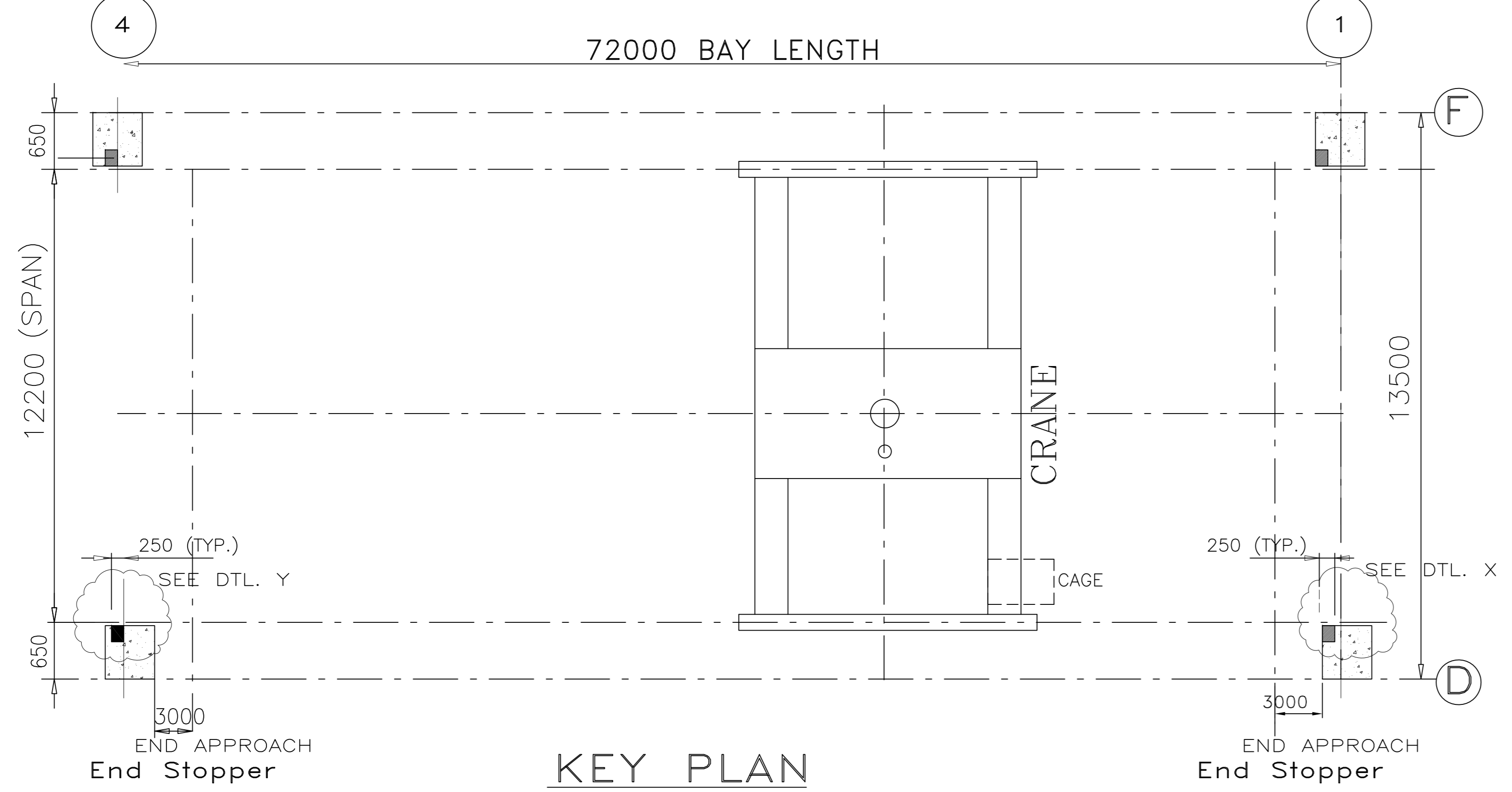

PROJECT:	ARUN-3 HYDRO ELECTRIC PROJECT (NEPAL) (4 x 225 MW)		
CUSTOMER:	SJVN ARUN-3 POWER DEVELOPMENT COMPANY PVT. LTD. (SAPDC LTD.)		
CONSULTANT:	SJVN LTD. (A JOINT VENTURE OF GOVT OF INDIA AND GOVT OF HP)		
BHARAT HEAVY ELECTRICALS LTD. TRANSMISSION BUSINESS GROUP NOIDA	NAME	SIGN.	DATE
	DRN. AJ		30/09/2021
	CHD. TDT		30/09/2021
APPD. SKS		30/09/2021	

DEPT. TBG CODE	SCALE NTS	CARD CODE	DRG. NO. TB-CCD-405-563-221 00
TITLE	CRANE CLEARANCE DIAGRAM FOR 10T DOUBLE GIRDER EOT CRANE OF GIS BUILDING OF 4x225MW ARUN-3 HEP		NO. OF SHT. 01
SHT. No			

REV.	DATE	ALTERED	REV.	DATE	ALTERED	REV.	DATE	ALTERED	REV.	DATE	ALTERED
		CHD/APPD			CHD/APPD			CHD/APPD			CHD/APPD
ZONE			ZONE			ZONE			ZONE		

THE INFORMATION ON THIS DOCUMENT IS THE PROPERTY OF BHARAT HEAVY ELECTRICALS LIMITED. IT MUST NOT BE USED DIRECTLY OR INDIRECTLY IN ANY WAY DETRIMENTAL TO THE INTEREST OF THE COMPANY