

BHARAT HEAVY ELECTRICALS LIMITED
Tiruchirapalli-620014

List of documents to be submitted

BHEL Enquiry No: RCSIGV2443

List of documents to be submitted in Part 1 Bid

The following documents with sign and seal are to be submitted in Part-1 bid for techno-commercial evaluation:

1. Scope of supply
2. Pre-Qualification Requirements
3. Drawings, Specification and TDC
4. Confirmation to terms and conditions
5. Schedule of deviation (in case of any deviation)
6. Enquiry General Terms and Conditions
7. Minimum Local Content Declaration Certificate
8. Udyam Registration Certificate

Document to be submitted in Part 2 Bid

The following excel price sheet to be submitted in Part-2 bid:

1. Price sheet –BOQ excel sheet

Scope of Supply

Item No	Material Code	Material Description	Drawing No/Rev No	TDC No/Spec.Rev No	Quantity (Nos)*	Delivery Period from PO date	Supplier's Response (Quoted/not Quoted)
1	964532430000	SOFT IRON GASKET-W016	2VW01615634/02	TDC:5:158/00	100	10 Weeks	
2	964532400000	SOFT IRON GASKET SI.PL-W007	2VW00715634/02	TDC:5:158/00	600	10 Weeks	
3	964532410000	SOFT IRON GASKET-W010	2VW01015634/02	TDC:5:158/00	120	10 Weeks	
4	964532420000	SOFT IRON GASKET-W013	2VW01315634/02	TDC:5:158/00	20	10 Weeks	
5	964532440000	SOFT IRON GASKET SI.PL-W019	2VW01915634/02	TDC:5:158/00	20	10 Weeks	
6	964532480000	SOFT IRON GASKET SI.PL-W058	2VW05815634/02	TDC:5:158/00	20	10 Weeks	
7	964532450000	SOFT IRON GASKET(SIL. PL)-W022	2VW02215634/02	TDC:5:158/00	40	10 Weeks	
8	964532460000	SOFT IRON GASKET-W050	2VW05015634/02	TDC:5:158/00	80	10 Weeks	
9	964532470000	SOFT IRON GASKET(SIL. PL)-W054	2VW05415634/02	TDC:5:158/00	80	10 Weeks	
10	964532490000	SOFT IRON GASKET SI.PL-W062	2VW06215634/02	TDC:5:158/00	40	10 Weeks	
11	964532500000	SOFT IRON GASKET-W066	2VW06615634/02	TDC:5:158/00	20	10 Weeks	
12	964532530000	SOFT IRON GASKET SI.PL-W078	2VW07815634/02	TDC:5:158/00	40	10 Weeks	
13	964532540000	SOFT IRON GASKET SIL.PL-G005	2VG00515634/02	TDC:5:158/00	400	10 Weeks	
14	964532550000	SOFT IRON GASKET(SIL.PL.)-G008	2VG00815634/02	TDC:5:158/00	200	10 Weeks	
15	964532560000	SOFT IRON GASKET-G014	2VG01415634/02	TDC:5:158/00	140	10 Weeks	
16	964532570000	SOFT IRON GASKET-L007	2VL00715634/02	TDC:5:158/00	40	10 Weeks	
17	964532580000	SOFT IRON GASKET SI.PL-L010	2VL01015634/02	TDC:5:158/00	20	10 Weeks	
18	964532590000	SOFT IRON GASKET SI.PL-L030	2VL03015634/02	TDC:5:158/00	40	10 Weeks	
19	964532600000	SOFT IRON GASKET SI.PL-L034	2VL03415634/02	TDC:5:158/00	40	10 Weeks	
20	964532610000	SOFT IRON GASKET SI.PL-W114	2VW11415634/02	TDC:5:158/00	60	10 Weeks	
21	964532620000	SOFT IRON GASKET-W118	2VW11815634/02	TDC:5:158/00	20	10 Weeks	
22	964532630000	SOFT IRON GASKET-G042	2VG04215634/02	TDC:5:158/00	300	10 Weeks	
23	964532660000	SOFT IRON GASKET SI.PL-L074	2VL07415634/02	TDC:5:158/00	20	10 Weeks	
24	964532680000	SOFT IRON GASKET SI.PL-W410	2VW41015634/02	TDC:5:158/00	20	10 Weeks	
25	964532690000	SOFT IRON GASKET SI.PL-R066	2VR06615634/02	TDC:5:158/00	40	10 Weeks	
26	964532700000	SOFT IRON GASKET SI.PL-W338	2VW33815634/02	TDC:5:158/00	40	10 Weeks	
27	964532710000	SOFT IRON GASKET SI.PL-W354	2VW35415634/02	TDC:5:158/00	20	10 Weeks	
28	964532740000	SOFT IRON GASKET-L004	3VL00420823/01	TDC:5:158/00	200	10 Weeks	

Scope of Supply

Item No	Material Code	Material Description	Drawing No/Rev No	TDC No/Spec.Rev No	Quantity (Nos)*	Delivery Period from PO date	Supplier's Response (Quoted/not Quoted)
29	964532750000	SOFT IRON GASKET-L007	3VL00720823/01	TDC:5:158/00	40	10 Weeks	
30	964532760000	SOFT IRON GASKET-L010	3VL01020823/01	TDC:5:158/00	40	10 Weeks	
31	964532770000	SOFT IRON GASKET-L026	3VL02620823/01	TDC:5:158/00	140	10 Weeks	
32	964532780000	SOFT IRON GASKET-L034	3VL03420823/01	TDC:5:158/00	60	10 Weeks	
33	964532820000	SOFT IRON GASKET-L170	3VL17020823/01	TDC:5:158/00	20	10 Weeks	
34	964532790000	SOFT IRON GASKET-L130	3VL13020823/01	TDC:5:158/00	20	10 Weeks	
35	964532810000	SOFT IRON GASKET(SI.PL.)-L178	3VL17820823/01	TDC:5:158/00	40	10 Weeks	
36	964532830000	SOFT IRON GASKET-L154	3VL15420824/01	TDC:5:158/00	300	10 Weeks	
37	964532840000	SOFT IRON GASKET-L130	3VL13020824/01	TDC:5:158/00	20	10 Weeks	
38	964532870000	SOFT IRON GASKET-L090	3VL09020824/01	TDC:5:158/00	40	10 Weeks	
39	964532880000	SOFT IRON GASKET-L178	3VL17820824/01	TDC:5:158/00	20	10 Weeks	
40	964532890000	SOFT IRON GASKET-L170	3VL17020824/01	TDC:5:158/00	20	10 Weeks	
41	964532900000	SOFT IRON GASKET-W442	3VW44220824/01	TDC:5:158/00	20	10 Weeks	
42	964532910000	SOFT IRON GASKET-W458	3VW45820824/01	TDC:5:158/00	20	10 Weeks	
43	964534520000	GASKET (SILVER PLATED)-W730	3VW73021095/00	TDC:5:158/00	20	10 Weeks	
44	964563270000	SELFSEALING RING-2700	3V270017027/01	TDC:5:158/00	20	10 Weeks	
45	964665740000	SOFT IRON GASKET (SPINDLE)-LP01	4VLP0119784/00	SPEC:CV:0015/00	100	10 Weeks	
46	964665750000	SOFT IRON GASKET-LP01	4VLP0119785/00	SPEC:CV:0015/00	100	10 Weeks	

* The quantities mentioned in the enquiry are indicative for the entire Rate contract period

Seal and Signature of authorized signatory with date

3.2 / 0.8

S.NO	DRAWING NO.	MATERIAL.		DIMENSIONS										FINISHED WEIGHT	TOA DRAWING NO.	SIZE/RATING
		SPECN.	CODE	D1	D2	L	L1	T	T1	T2	RA	RB				
1.	2-V-W007-15634/2	96 453 240	95 85 10	5	5	0.75	1	3	0.5	0.072	4-E47417 (0065)	65/2500 & 80/1500				
2.	2-V-W010-15634/2	96 453 241	125 111 14	7	7	0.75	1.5	3	0.5	0.195	4-E47426 (0036)	100/2500				
3.	2-V-W013-15634/2	96 453 242	250 220 30	15	15	1	2	5	1	1.69	4-E47464 (0101)	200/2500				
4.	2-V-W016-15634/2	96 453 243	285 250 35	17.5	17.5	1	2	5	1	2.58	4-E47479 (0136)	250/2500				
5.	2-V-W019-15634/2	96 453 244	335 295 40	20	20	1	2	5	1	3.93	4-E47496 (0197)	300/2500				
6.	2-V-W022-15634/2	96 453 245	380 330 50	25	25	1	2.5	5	1	6.98	4-E47504 (0169)	350/2500				
7.	2-V-W050-15634/2	96 453 246	110 96 14	7	7	0.75	1.5	3	0.5	0.17	4-E47423 (0554)	65/1500				
8.	2-V-W054-15634/2	96 453 247	140 126 14	7	7	0.75	1.5	3	0.5	0.220	4-E47429 (0583)	100/1500 & 150/2500				
9.	2-V-W058-15634/2	96 453 248	210 186 24	12	12	1	1.5	5	0.5	0.890	4-E47452 (0619)	150/1500				
10.	2-V-W062-15634/2	96 453 249	335 305 30	15	15	1	2	5	1	2.30	4-E47473 (0652)	300/1500				
11.	2-V-W066-15634/2	96 453 250	175 151 24	12	12	1	1.5	5	0.5	0.73	4-E58446 (0676)	150/2500				
12.	2-V-W070-15634/2	96 453 251	410 360 50	25	25	1	2.5	5	1	7.56	4-E47508 (0711)	400/2500				
13.	2-V-W074-15634/2	96 453 252	450 400 50	25	25	1	2.5	5	1	8.34	4-E47513 (0739)	450/2500				
14.	2-V-W078-15634/2	96 453 253	465 405 60	30	30	1	2.5	5	1	12.7	4-E58762 (0767)	500/2750				
15.	2-V-G005-15634/2	96 453 254	115 101 14	7	7	0.75	1.5	3	0.5	0.18	4-E47424 (0213)	100/1500 & 100/2500				
16.	2-V-G008-15634/2	96 453 255	140 122 18	9	9	0.75	1.5	3	0.5	0.35	4-E47436 (0232)	150/2500				
17.	2-V-G014-15634/2	96 453 256	100 86 14	7	7	0.75	1.5	3	0.5	0.15	4-E47421 (0010)	65/3500 & 80/2500				
18.	2-V-L007-15634/2	96 453 257	190 166 24	12	12	1	1.5	5	0.5	0.80	4-E47448 (0280)	200/2500				
19.	2-V-L010-15634/2	96 453 258	270 240 30	15	15	1	2	5	1	1.83	4-E47467 (0306)	300/2500				
20.	2-V-L030-15634/2	96 453 259	325 290 35	17.5	17.5	1	2	5	1	2.96	4-E47485 (0472)	350/2500				
21.	2-V-L034-15634/2	96 453 260	420 370 50	25	25	1	2.5	5	1	7.76	4-E47511 (0500)	450/2500				
22.	2-V-W114-15634/2	96 453 261	250 226 24	12	12	1	1.5	5	0.5	1.07	4-E47457 (0812)	200/1500				
23.	2-V-W118-15634/2	96 453 262	295 265 30	15	15	1	2	5	1	2.01	4-E47471 (0847)	250/1500				
24.	2-V-G042-15634/2	96 453 263	90 80 10	5	5	0.75	1	3	0.5	0.068	4-E47416 (0868)	65/1500				
25.	2-V-L058-15634/2	96 453 264	175 157 18	9	9	0.75	1.5	3	0.5	0.44	4-E47442 (0949)	150/1500				
26.	2-V-L082-15634/2	96 453 265	315 280 35	17.5	17.5	1	2	5	1	2.87	4-E47483 (1241)	350/2500 STOP CHECK				
27.	2-V-L074-15634/2	96 453 266	350 310 40	20	20	1	2	5	1	4.11	4-E47497 (1272)	300/2000 ELB				
28.	2-V-G138-15634/2	96 453 267	385 335 50	25	25	1	2.5	5	1	7.08	4-E47505 (1209)	400/2500 GLOBE NEEDLE				
29.	2-V-W410-15634/2	96 453 268	370 335 35	17.5	17.5	1	2	5	1	3.39	4-E47490	350/1500				
30.	2-V-R066-15634/2	96 453 269	135 121 14	7	7	0.75	1.5	3	0.5	0.211	4-E47428	125/1500				
31.	2-V-W338-15634/2	96 453 270	115 97 18	9	9	0.75	1.5	3	0.5	0.282	4-E47432 (1670)	80/3500				
32.	2-V-W354-15634/2	96 453 271	145 127 18	9	9	0.75	1.5	3	0.5	0.361	4-E47437 (1642)	125/2500				
33.	2-V-W516-15634/2	96 453 272	480 420 60	30	30	1	2.5	5	1	12.54	4-E47516 (2256)	450/2000				

SOFT IRON

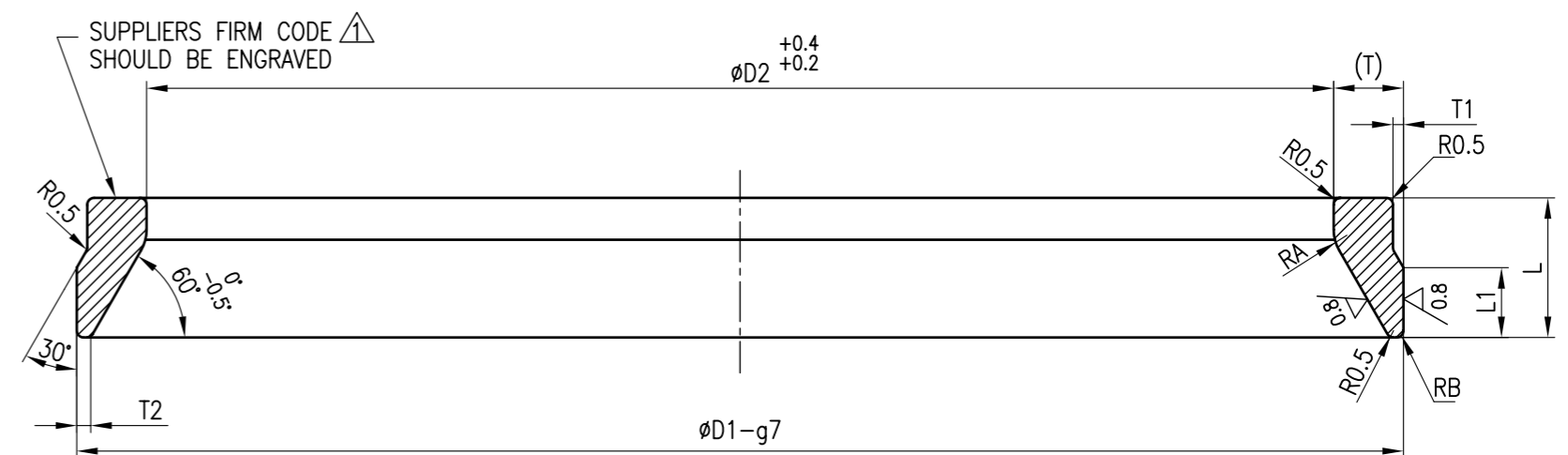

ø 80 TO	-0.012
ø 120 g7	-0.047
ø 120 TO	-0.014
ø 180 g7	-0.054
ø 180 TO	-0.015
ø 250 g7	-0.061
ø 250 TO	-0.017
ø 315 g7	-0.069
ø 315 TO	-0.018
ø 400 TO	-0.075
ø 400 TO	-0.020
ø 500 g7	-0.083

NOTES :

01. APPLICABLE LATEST T D C SHALL BE FOLLOWED IN ALL RESPECTS.
02. HARDNESS: MAX, 90 BHN.
03. GASKETS SHALL BE SILVER PLATED TO A THICKNESS OF 0.0127mm MAX.
04. THE DIMENSIIONS GIVEN IN THE TABULAR COLUMN IS AFTER SILVER PLATING.

REDRAWN WITH REV.2 ON 12.04.08

No OFF	DESCRIPTION	MATL CODE	MATL SPECN	HEAT TREATMENT	SCRAP SORT	NET WT (kg)	GROSS WT (kg)	DRAWING No	ITEM No
TYPE OF PRODUCT OR NAME OF CUSTOMER/PROJECT									
BHARAT HEAVY ELECTRICALS LTD., UNIT: HIGH PRESSURE BOILER PLANT. TIRUCHIRAPALLI -620014.				DRN	V.SIVALINGAM	SIGN	DATE	NO.OF VAR.	
365-120				CHD	K.RAJASEKARAN		12.04.08		
DEPT VL				APPD	M.RAJAKUMAR		12.04.08		
DRAWING CONVERTED INTO SOFT COPY				SCALE N T S			REFERENCE INFORMATIONS		
DCP No.800813				GASKET			DRAWING NO. 2-V-0000-15634		
				CARD CODE U 01			REV 2		

CAUTION: The information on this document is the property of BHARAT HEAVY ELECTRICALS LTD. It must not be used directly or indirectly in any way detrimental to the interest of the company.

3-V-0000-17027/02
DRAWING NO.

ALL DIMENSIONS ARE IN MILLIMETRES

3.2 / 0.8

SL. NO.	DRAWING NO.	MATL. SPECN.	MATL. CODE	∅D	∅D1	∅D2-g7	T	T1	T2	f	Wt. (Kg)	VALVE TYPE
01	3-V-1524-17027/01	SOFT IRON	96 456 324	140	148	170	21	6	3	2.5	0.8	150/250/IX GV
02	3-V-1532-17027/01		96 456 325	190	198	230	25	8	3	3	1.43	250/250/IX GV 200/250/IX CV
03	3-V-1936-17027/01		96 456 326	104	108	125	18	6	3	2.5	0.34	65/250/IX SV,RV,CV,&GV 100/250/IX GV
04	3-V-2700-17027/01		96 456 327	124	128	150	17	6	3	2.5	0.84	100/250/IX SV, RV, CV
05	3-V-3115-17027/01		96 456 328	166	172	200	23	8	3	3	1.02	150/250/IX CV 200/250/IX GV
06	3-V-3119-17027/01		96 456 329	240	245	280	30	8	8	3.5	2.48	250/250/IX CV
07	3-V-1288-17027/01		96 456 330	265	287	330	40	8	3	3.5	4.8	300/250/IX GV
08	3-V-0160-17027		96 456 788	204	210	230	18	7	3	2.5	0.7	250/160/IX GV

∅120-∅180 g7	-0.014
	-0.054
∅180-∅250 g7	-0.015
	-0.061
∅250-∅315 g7	-0.017
	-0.069
∅315-∅400 g7	-0.018
	-0.075

NOTES:-

- LATEST APPLICABLE TDC SHALL BE FOLLOWED IN ALL RESPECTS
- HARDNESS - MAX. 90 BHN.
- SEAL PEEL TREATMENT SHOULD BE CARRIED OUT AS A RUST PROOF TREATMENT DURING STORAGE.

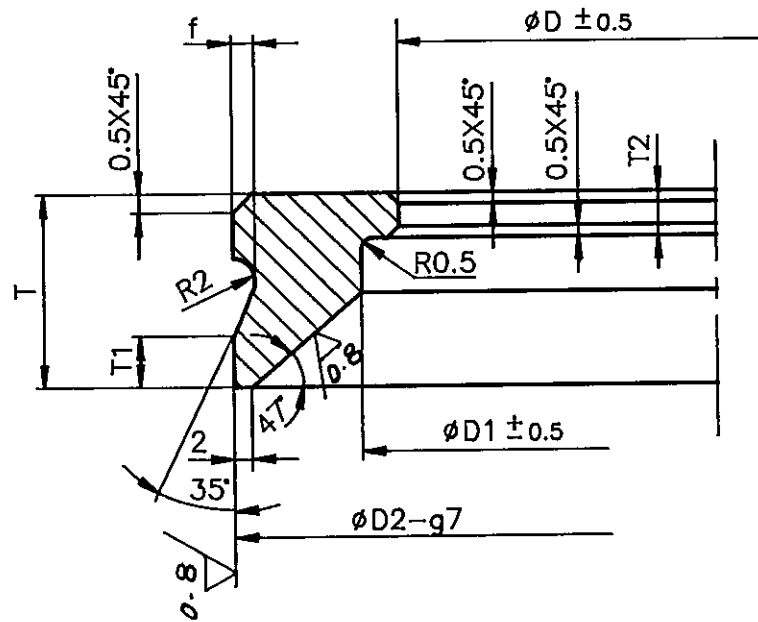

NO OFF	DESCRIPTION	MATL CODE	MATL SPECN	HEAT TREATMENT	SCRAP SORT	NET WT (kg)	GROSS WT (kg)	DRAWING No	ITEM No
	TYPE OF PRODUCT OR NAME OF CUSTOMER/PROJECT	TA							
	BHARAT HEAVY ELECTRICALS LTD., UNIT: HIGH PRESSURE BOILER PLANT. TIRUCHIRAPALLI-620014.	DRN	NAME	SIGN	DATE	NO. OF VAR.			
		CHD	R.L.NARAYANAN	<i>R.L.Narayanan</i>	19/11/93				
		APPD	M.R.K.	<i>M.R.K.</i>	20/11/93				
DEPT VL	SCALE	WEIGHT (KG)	REFERENCE INFORMATION						NO. OF ITEMS
CODE 320	NTS	-	CAD NO. T317027						
TITLE	CARD CODE	DRAWING NO.	REV						
SELF SEALING RING		U 01	3-V-0000-17027						02

CAUTION: The information on this document is the property of BHARAT HEAVY ELECTRICALS LTD. It must not be used directly or indirectly in any way detrimental to the interest of the company.

REV.	DATE	ALT. R.L.	REV.	DATE	ALTERED
02	10.1.97	<i>CHE. APPD. M.R.K.</i>	01	11.3.95	<i>CHED: BAPPD: M.R.K.</i>

SL. No. 08 INCLUDED.

NOTE 1 MODIFIED
DCN No - TA 0472

ALL DIMENSIONS ARE IN MILLIMETRES. FOR TOLERANCES OF UNTOLERANCED DIMENSIONS DURING MANUFACTURE REFER RELEVANT QCP / QP.

2802-0000-A-3
ON DRAWING

SL. NO.	DRAWING NO.	MATL. SPECN.	MATERIAL CODE	TOA DRAWING NO.	DIMENSIONS			FINISHED WEIGHT (kg)	SIZE / RATING
					φd g7	H	(T)		
1	3-V-L004-20823/1		964532740000	4-E47882 (0258)	20 -0.007 -0.028	8	3	0.01	100/1500 150/2500
2	3-V-L007-20823/1		964532750000	4-E47883 (0279)	24 -0.007 -0.028	8	3	0.01	150/1500 200/2500
3	3-V-L010-20823/1		964532760000	4-E47887 (0305)	40 -0.009 -0.034	8	4	0.02	350/2500 300/2500
4	3-V-L026-20823/1		964532770000	4-E47881 (0448)	16 -0.006 -0.024	8	3	0.01	65/1500 80/2500
5	3-V-L034-20823/1	SOFT IRON	964532780000	4-E47893 (0499)	53 -0.010 -0.040	10	5	0.04	450/2500
6	3-V-L130-20823/1		964532790000	4-E47885 (1768)	32 -0.009 -0.034	8	4	0.02	250/1500
7	3-V-L106-20823/1		964532800000	4-E47886 (1877)	36 -0.009 -0.034	8	4	0.02	300/1500
8	3-V-L178-20823/1		964532810000	4-E47884 (2000)	28 -0.007 -0.028	8	3	0.01	250/2500
9	3-V-L170-20823/1		964532820000	4-E47888 (1973)	45 -0.009 -0.034	8	4	0.02	400/2500

32/08/17

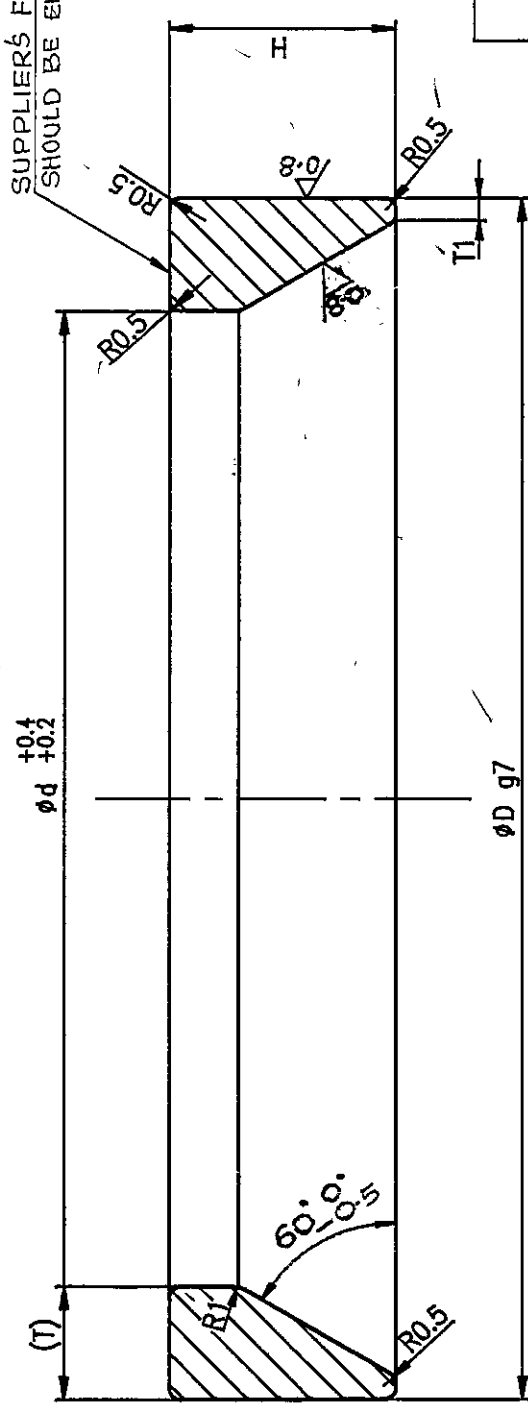

NOTES

1. HARDNESS MAX. 90 BHN.
2. APPLICABLE LATEST TDC SHALL BE FOLLOWED IN ALL RESPECTS.
3. GASKETS SHALL BE SILVER PLATED TO A THICKNESS OF 0.0127 mm MAX.
4. THE DIMENSIONS GIVEN IN TABULAR COLUMN IS AFTER SILVER PLATING.



TYPE OF PRODUCT
OR NAME OF
CUSTOMER/PROJECT

NO OFF	DESCRIPTION	MATL CODE	MATL SPECN	HEAT TREATMENT	SCRAP SORT	NET WT (kg)	GROSS WT (kg)	DRAWING NO	ITEM NO
BHARAT HEAVY ELECTRICALS LTD., UNIT: HIGH PRESSURE BOILER PLANT, TRICHIRAPALLI-620014									
DEPT VL	SCALE	WEIGHT (KG)	REFERENCE INFORMATION						
CODE 320	N F S		DRN	NAME	SIGN	DATE	NO OF VAR		
TITLE			CHD	V.SIVALINGAM	V.S. Sivalingam	19.10.95			
			APPD	K.RAJASEKARAN	K.R. Rajasekaran	27.10.95			
				M.RAJAKUMAR	M. Rajakumar	11.11.95			
GASKET			CARD CODE	DRAWING NO.			REV		
			U 01	3-V-0000-20823			1		

CAUTION: The information on this document is the property of BHARAT HEAVY ELECTRICALS LTD. It must not be used directly or indirectly in any way detrimental to the interest of the company.

REV	DATE	ALTERED BY
1	5-2-99	CHD & APPD WAF/WL
SUPPLIER'S FIRM CODE ON GASKETS INTRODUCED.		
DCN No. TAO976		

ALL DIMENSIONS ARE IN MILLIMETRES. FOR TOLERANCES OF UNTOLERANCED DIMENSIONS DURING MANUFACTURE REFER RELEVANT QCP / QP.

DRAWING NO. 3-V-0000-20824-1

SL. NO.	DRAWING NO.	MATERIAL SPECN.	MATERIAL CODE	TOA DRAWING NO.	DIMENSIONS										FINISHED WEIGHT (Kg)	SIZE / RATING
					ØD1	ØD2	L	L1	T	T1	T2	RA	Rb			
1	3-V-L154-20824/1		964532830000	4-E47422 (1950)	105	91	14	7	7	0.75	1.5	3	0.5	0.16	80/1500 80/2500 GLOBE	
2	3-V-L130-20824/1		964532840000	4-E47458 (1769)	255	231	24	12	12	1	1.5	5	0.5	1.09	250/1500	
3	3-V-L106-20824/1		964532850000	4-E47472 (1878)	300	270	30	15	15	1	2	5	1	2.09	300/1500	
4	3-V-L122-20824/1		964532860000	4-E47486 (1797)	330	295	35	17.5	17.5	1	2	5	1	3.01	350/1500	
5	3-V-L090-20824/1		964532870000	4-E47425 (1746)	120	106	14	7	7	0.75	1.5	3	0.5	0.19	125/2500	
6	3-V-L178-20824/1		964532880000	4-E47453 (2001)	220	196	24	12	12	1	1.5	5	0.5	0.94	250/2500	
7	3-V-L170-20824/1		964532890000	4-E47498 (1974)	360	320	40	20	20	1	2	5	1	4.23	400/2500 350/2000 GATE	
8	3-V-W442-20824/1		964532900000	4-E47441 (2150)	170	152	18	9	9	0.75	1.5	3	0.5	0.43	125/1500	
9	3-V-W458-20824/1		964532910000	4-E68133 (2051)	475	415	60	30	30	1	2.5	5	1	12.76	450/1500	
10	3-V-W418-20824/1		964532920000	4-E47521 (1826)	540	480	60	30	30	1	2.5	5	1	14.19	600/1500	

SOFT IRON

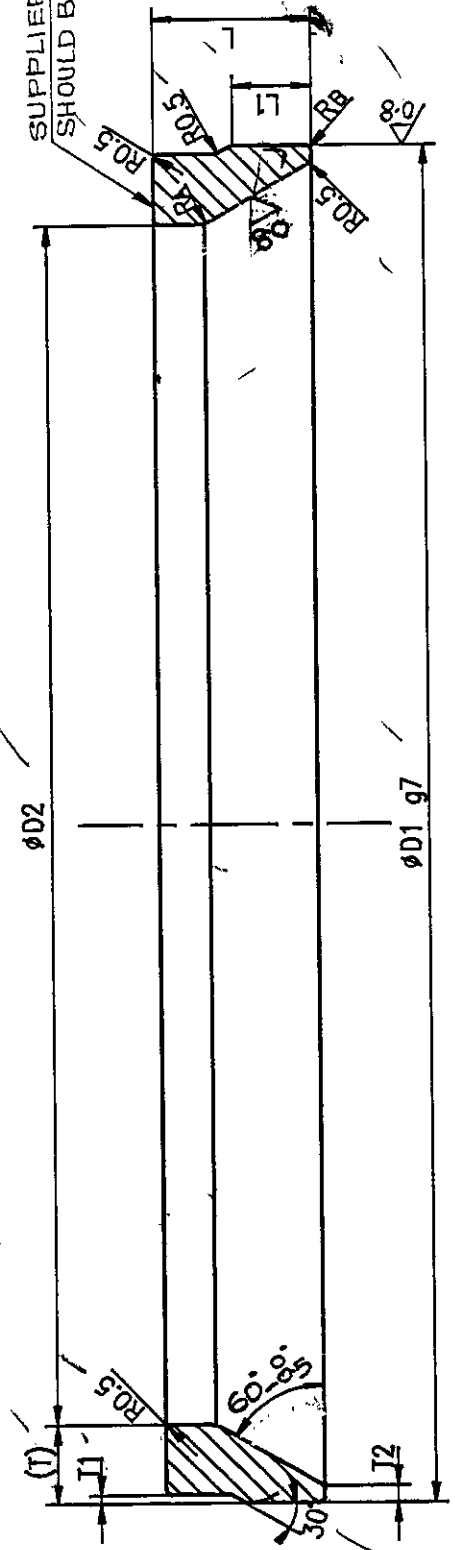

SUPPLIER'S FIRM CODE SHOULD BE ENGRAVED

NOTES

- HARDNESS MAX. 90 BHN.
- APPLICABLE LATEST I.D.C SHALL BE FOLLOWED IN ALL RESPECTS.
- GASKETS SHALL BE SILVER PLATED TO A THICKNESS OF 0.0127 mm MAX.
- THE DIMENSIONS GIVEN IN THE TABULAR COLUMN IS AFTER SILVER PLATING.

NO OFF	DESCRIPTION	MATL CODE	MATL SPECN	HEAT TREATMENT	SCRAP SORT	NET WT (KG)	GROSS WT (KG)	DRAWING No	ITEM No

TYPE OF PRODUCT OR NAME OF CUSTOMER/PROJECT



BHARAT HEAVY ELECTRICALS LTD.
UNIT: HIGH PRESSURE BOILER PLANT.
TIRUCHIRAPPALLI-620014.

NAME	SIGN	DATE	NO. OF VAR
V.SIVALINGAM	V. Sivalingam	20/10/95	
K. RAJASEKARAN	K. Rajasekaran	27-10-95	
M. RAJAKUMAR	M. Rajakumar	11/11/95	

CAUTION: The information on this document is the property of BHARAT HEAVY ELECTRICALS LTD. It must not be used directly or indirectly in any way detrimental to the interest of the company.

REV	DATE	ALTERED BY
1	5-2-99	CHD & APPD M.V.M.

SUPPLIER'S FIRM CODE ON GASKETS INTRODUCED.

DCN No. TA0976

DRAWING NO. 3-V-0000-20824-1

GASKET

Size AS

ALL DIMENSIONS ARE IN MILLIMETRES. FOR TOLERANCES OF UNTOLERANCED DIMENSIONS DURING MANUFACTURE REFER RELEVANT QCP / QP.

56012-0000-A-3
DRAWING NO.

SL. NO.	DRAWING NO.	MATERIAL SPECN.	MATERIAL CODE	TOA DRAWING NO.	DIMENSIONS							FINISHED WEIGHT (Kg)	SIZE / RATING			
					ØD1	ØD2	L	L1	T	T1	T2			RA	RB	
1	3-V-W738-21095	SO7 IRON	964534510000	4-E47494	325	285	40	20	(20)	1	2	5	5	1	3.80	350/3000
2	3-V-W730-21095		964534520000	4-E47445	170	146	24	12	(12)	1	1.5	5	5	0.5	0.712	150/3000
3	3-V-R272-21095		964534530000	4-E47449	195	171	24	12	(12)	1	1.5	5	5	0.5	1.04	150/3000

Ø325 g7	-0.018
Ø195 g7	-0.075
Ø170 g7	-0.015
	-0.061
	-0.014
	-0.054

3.2/0.8

29 W 24 R

NOTES:-

- HARDNESS MAX. 90 BHN.
- APPLICABLE LATEST TDC SHALL BE FOLLOWED IN ALL RESPECTS.
- GASKETS SHALL BE SILVER PLATED TO A THICKNESS OF 0.0127mm MAX. AFTER SILVER PLATING.
- THE DIMENSIONS GIVEN IN THE TABULAR COLUMN IS

SUPPLIER'S FIRM CODE

SHOULD BE ENGRAVED

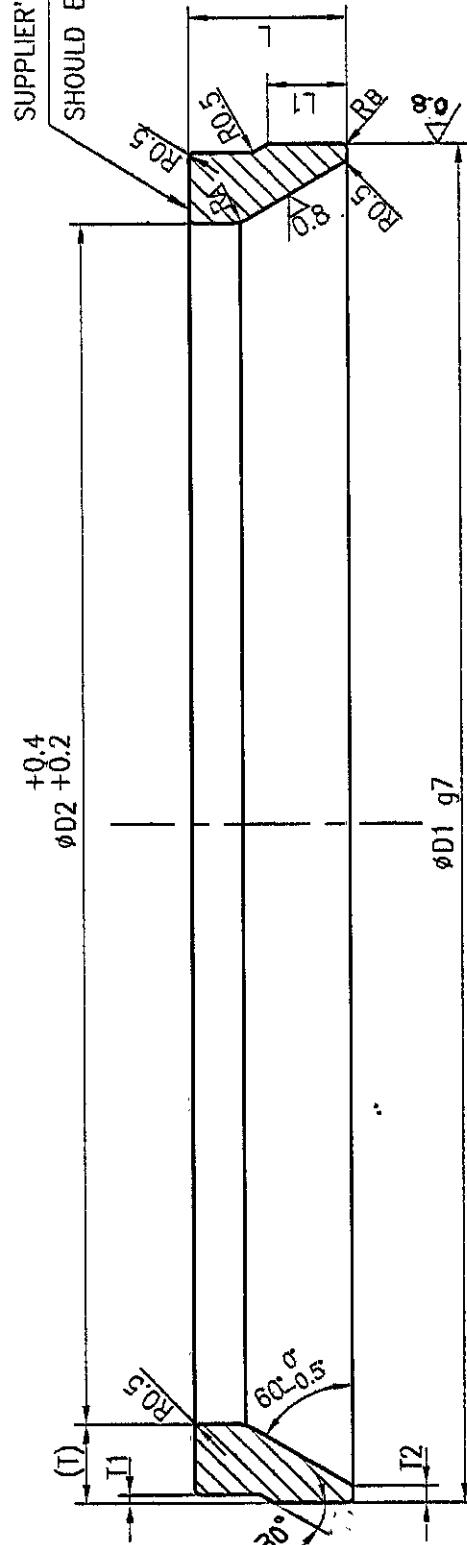

TYPE OF PRODUCT
OR NAME OF
CUSTOMER/PROJECT

TA
BHARAT HEAVY ELECTRICALS LTD.,
UNIT: HIGH PRESSURE BOILER PLANT,
TIRUCHIRAPPALLI-620014.

CAUTION: The information on this document is the property of BHARAT HEAVY ELECTRICALS LTD. It must not be used directly or indirectly in any way detrimental to the interest of the company.

REV	DATE	ALTERED
		CHD & APPD

DEPT VL
CODE 320
TITLE

SCALE N T S

WEIGHT (KG)

REFERENCE INFORMATION

CAD REF. NO. : T321095

DRAWING NO. 3-V-0000-21095

REV 0

NO OFF	DESCRIPTION	MATL CODE	MATL SPECN	HEAT TREATMENT	SCRAP SORT	NET WT (kg)	GROSS WT (kg)	DEPARTING NO	ITEM NO

CAUTION: The information on this document is the property of BHARAT HEAVY ELECTRICALS LTD. It must not be used directly or indirectly in any way detrimental to the interest of the company.

DCP No.	ALTD:	APPD:
	CHD:	DT:
REV		
ZONE		

3.2 / 0.8

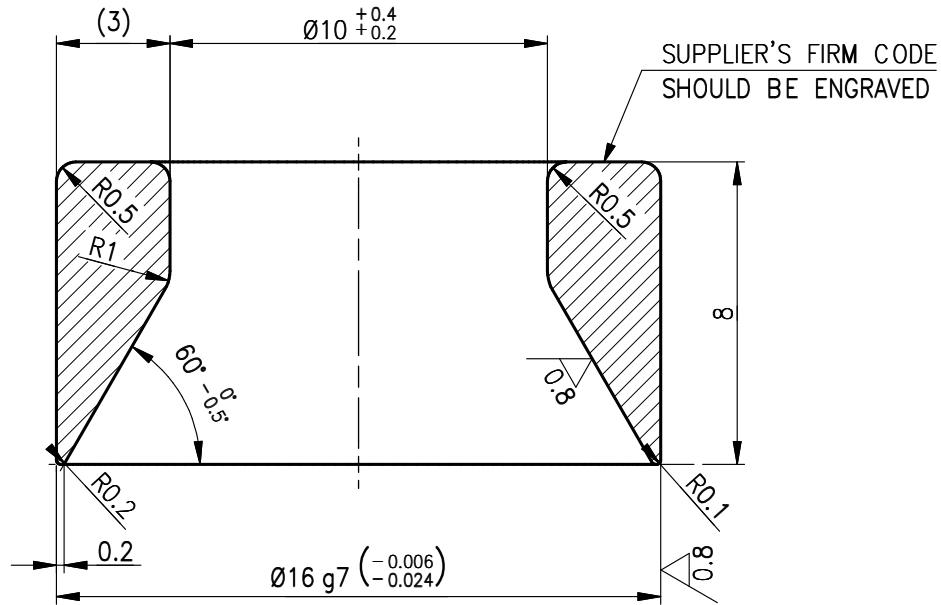

NOTES:

1. LATEST APPLICABLE QUALITY PROCEDURE SHALL BE FOLLOWED IN ALL RESPECTS.
2. HARDNESS MAXIMUM 90 BHN.
3. GASKET SHALL BE SILVER PLATED TO A THICKNESS OF 0.0127 MM MAX.
4. THE DIMENSIONS GIVEN ARE AFTER THE SILVER PLATING.

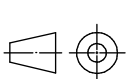
01	-	-	SOFT IRON	-	-	-	-	4-V-LP01-19784	-
								96 466 574 0000	
S.R. NO.	DESCRIPTION	MATL CODE	MATL SPECN	HEAT TREATMENT	SCRAP SORT	NET WT (kg)	GROSS WT (kg)	DRAWING No	ITEM No
								COMP. CODE	
 BHARAT HEAVY ELECTRICALS LTD. UNIT: HIGH PRESSURE BOILER PLANT. TIRUCHIRAPALLI 620014.					DRN	NAME	SIGN	DATE	NO. OF VAR
					CHD	R.P.SINGH		31.03.23	
					APPD	MUKESH KUMAR		31.03.23	
						S.SATHEES		31.03.23	
DEPT VL	/		SCALE	WEIGHT (KG).	REFERENCE INFORMATIONS				NO. OF ITEMS
CODE 320			NTS	0.01	-				
TITLE					CARD CODE	DRAWING NO.			RE
GASKET (SPINDLE)					U 01	4-V-LP01-19784			00
3-C1500-NRV					API(6D)				



CAUTION: The information on this document is the property of BHARAT HEAVY ELECTRICALS LTD. It must not be used directly or indirectly in any way detrimental to the interest of the company.

DCP No.	ALTD:	APPD:
	CHD:	DT:
REV		
ZONE		

3.2 / 0.8

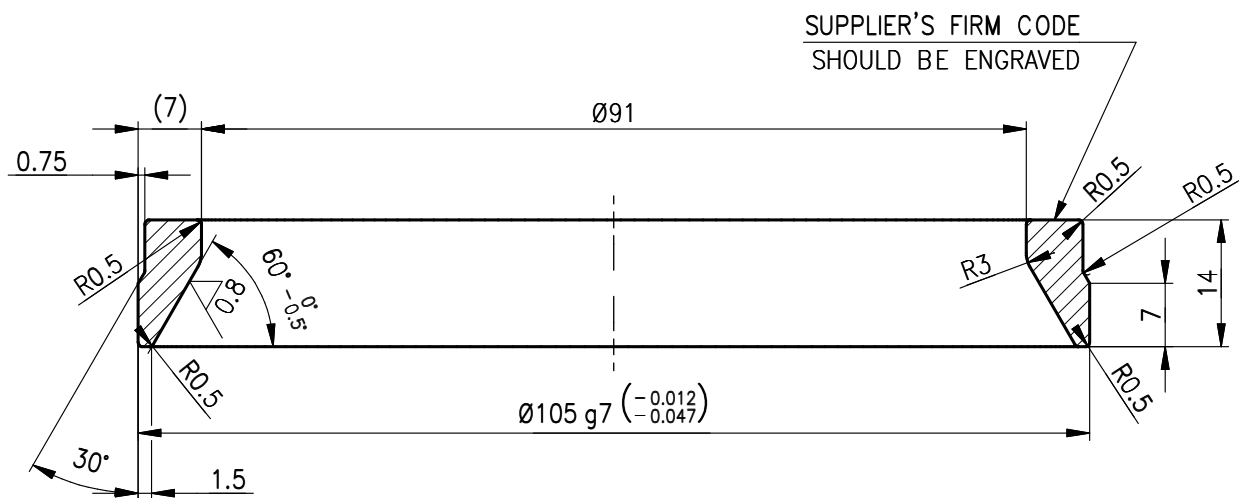

NOTES:

1. LATEST APPLICABLE QUALITY PROCEDURE SHALL BE FOLLOWED IN ALL RESPECTS.
2. HARDNESS MAXIMUM 90 BHN.
3. GASKET SHALL BE SILVER PLATED TO A THICKNESS OF 0.0127 MM MAX.
4. THE DIMENSIONS GIVEN ARE AFTER THE SILVER PLATING.

01	-	-	SOFT IRON	-	-	-	-	4-V-LP01-19785	-
								96 466 575 0000	
S.R. NO.	DESCRIPTION	MATL CODE	MATL SPECN	HEAT TREATMENT	SCRAP SORT	NET WT (kg)	GROSS WT (kg)	DRAWING No	ITEM No
								COMP. CODE	
<p>BHARAT HEAVY ELECTRICALS LTD. UNIT: HIGH PRESSURE BOILER PLANT. TIRUCHIRAPALLI 620014.</p>					DRN	NAME	SIGN	DATE	NO. OF VAR
					CHD	R.P.SINGH		31.03.23	
					APPD	MUKESH KUMAR		31.03.23	
						S.SATHEES		31.03.23	
DEPT VL	/		SCALE	WEIGHT (KG).	REFERENCE INFORMATIONS				NO. OF ITEMS
CODE 320			NTS	0.16	-	-			
TITLE					CARD CODE	DRAWING NO.			RE
GASKET					U 01	4-V-LP01-19785			00
3-C1500-NRV					API(6D)				



BHARAT HEAVY ELECTRICALS LIMITED
TIRUCHIRAPALLI. 620 014 INDIA

TECHNICAL DELIVERY
CONDITION FOR

MILD STEEL GASKETS FOR
VALVES

TDC:5:158
PAGE 01 OF 03

EFFECTIVE DATE 08-01-89

ACCEPTED BY	SIGNATURE	DATE
ENGINEERING	<i>[Signature]</i>	27/01/89
PURCHASE	<i>[Signature]</i>	28/1/89
QUALITY ASSURANCE	<i>[Signature]</i>	04/02/89
QUALITY CONTROL	<i>[Signature]</i>	27/1

REV. NO.	DATE	AUTHORISED BY	SIGNATURE
00	08/01/89	QUALITY ASSURANCE	<i>[Signature]</i>
		QUALITY ASSURANCE	

ISSUED BY : QUALITY ASSURANCE

SCOPE

This Technical Delivery Condition specifies the requirements for the supply of Mild Steel Gaskets for valves.

The dimensions, dimensional tolerances and quantity shall be as per drg. and purchase orders.

MATERIALS

The material shall be of plain low Carbon Steel (Equivalent to AISI 1010 or even less).

The material shall be in fully soft annealed condition with max. hardness of 90 BHN.

The above annealing operation must be carried out before the gasket is machined to the final shape and size.

MECHANICAL PROPERTIES

Hardness must be measured on the finished Gaskets and the same should not exceed 90 BHN.

WORKMANSHIP

The finished machined gaskets to the drg. dimensions must be free from rust, heat treatment scales, burrs and other defects.

MARKING AND PACKING

The finished gasket must be applied with a layer of plastic peel rust preventive to avoid rusting during storing. Before applying the plastic peel, the gasket must be identified by paint stencilling in the location given as overleaf

The gaskets must be packed in suitable wooden boxes to avoid transit damage.

CERTIFICATION

Each batch of the gaskets must be supplied with back up certificate for the following:

- a) P.O. Number
- b) T.C. Number and date
- c) Material quantity in each size
- d) Material chemistry
- e) Heat treatment condition
- f) Hardness

END USE

The gaskets are used in valves to arrest leakage of fluid through the bonnet area in the case of high pressure valves.

⊗ MARKING TO BE DONE ON THIS FACE

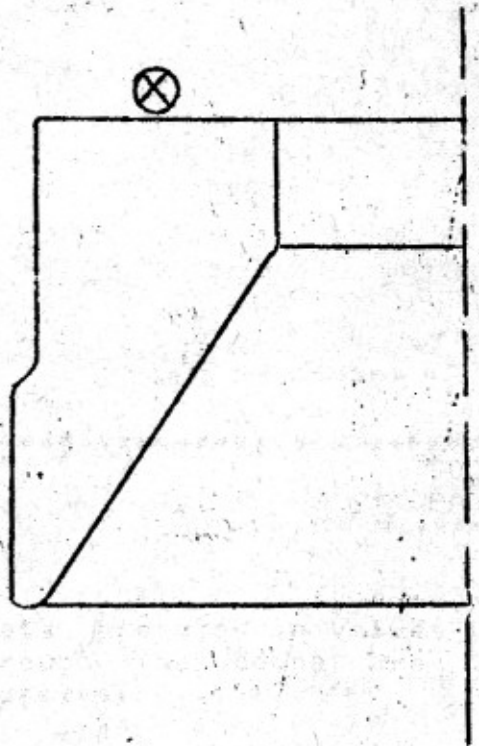



365-147/B
31.08.16

BHEL – Tiruchirappalli – 620014,
India

Valves Engineering and R&D

PURCHASE SPECIFICATION

DOC No: **SPEC:CV:0015** Rev: **00**

Effective Date: **20/06/2023**

Page: **1 of 2**

Product: Mild Steel Gasket for Valves for API 6D and NACE Application

Revision Record:

Rev. No	Date	Details of Revision
00	20 June 2023	New Release

1.0 Scope:

- This specification specifies the constructional functional and qualitative requirements of Mild Steel for use in valves at different pressures and temperatures.
- The Dimensions, Dimensional Tolerances and Quantity shall be as per drawing and purchase order.
- The Gaskets are used in Valves to arrest the leakage of fluid through the bonnet area and hinge spindle.

2.0 Material and Mechanical Properties:

- The material shall be of plain low carbon steel (Equivalent to AISI 1010 or even less)
- The material shall be in fully soft annealed condition with maximum hardness of 90 BHN.
- The above annealing operation must be carried out before the gasket is machined to the final shape and size.

3.0 Workmanship:

- The final machined gaskets to the drawing dimensions must be free from rust, heat treatment scales, burrs and other defects.

4.0 Marking and Packing:

- The finished gaskets must be applied with a layer of plastic peel rust preventive, to avoid rusting during storing.
- Before applying plastic peel, the gasket must be identified by paint stencilling in the location given in drawing.
- The gaskets must be packed in suitable wooden boxes to avoid transit damages.

5.0 Certification:

- Each Batch of gaskets must be supplied with back up certificate for the following:
 - P O Number
 - T C Number & Date
 - Material Quantity in each size
 - Material Chemistry
 - Heat Treatment Condition
 - Hardness
 - Compliance Certificate to meet all the requirements of this purchase specification

6.0 PQR

- Bidder shall submit the supply records for items manufactured with each type of materials indicated in the drawings
 - To fulfil this criteria, Bidder shall submit previous PO of same or identical items not more than 5 years old from date of part 1 bid opening.
- Bidders to submit a valid certificate of Quality Management System conforming to ISO 9001 / API Spec Q1 / internationally recognized quality management standard.



365-147/B
31.08.16

BHEL – Tiruchirappalli – 620014,
India

Valves Engineering and R&D

PURCHASE SPECIFICATION

DOC No: **SPEC:CV:0015** Rev: **00**

Effective Date: **20/06/2023**

Page: **2** of **2**

Product: Mild Steel Gasket for Valves for API 6D and NACE Application

- iii. Bidders to Confirm that they have validated NDE Procedures and records
- iv. Bidders are requested to detail out the deviations from this specification while submitting the offer. Even If no deviation is taken, vendor shall explicitly mention "No Deviation".
- v. Bidders to provide a Conformance to the requirements of this specification
 - a. To fulfil this criteria, Bidder to Confirm compliance to all the requirements mentioned in this purchase specification

Signature

Name

Ravi Pratap Singh

Mukesh Kumar

S Sathees Kumar

Designation

Dy. Engineer

Dy. Manager

Manager

Action

Prepared By

Checked & Reviewed By

Approved By

BHARAT HEAVY ELECTRICALS LIMITED
Tiruchirapalli-620014

Pre-Qualification Requirement Again tender –RCSIGV2443

Product: Soft Iron Gasket for Valves

Bidders should have supply history of soft iron gasket of Specifications AISI 1010, equivalent grades/specifications, in the last five years.

For fulfilling the experience criteria any one of the following documents may be considered as valid proof for meeting the experience criteria:

- a) Purchase Order copy(s) along with Invoice(s) with self-certification by the bidder that supplies against the invoices have been executed. Invoice(s) and Self-certification not required if BHEL, Trichy's Purchase Orders are submitted as proof.
- b) Execution certificate by client with order value.
- c) Any other document in support of order execution like Third Party Inspection release note, etc.

Bidder shall also submit any additional documentation requested by BHEL during the course of the tender evaluation process, to satisfy itself on the bidder's capability.



BHARAT HEAVY ELECTRICALS LTD

VALVES PURCHASE

Trichy - 620 014, India

CONFIRMATION TO TERMS AND CONDITIONS

Enquiry Reference: RCSIGV2443

<u>TERMS & CONDITION</u>	<u>VENDOR's response</u> (strike-off, whichever is not applicable)	<u>VENDOR REMARKS</u> (if any)
a. Vendor Name, Quotation No and date has to be clearly mentioned in both bids		
b. Rate Contract: This is an enquiry for finalization of a Rate Contract (RC) for a period as mentioned in 'Validity of offer' below. This is a value based contract and the quantities mentioned in the enquiry are indicative for the entire RC period. Purchase Orders will NOT be issued for the entire quantum in one lot, whereas POs will be released on a time to time basis during the RC period, based on actual requirement.	Accepted/ Not-accepted	
c. Bidder should give confirmation to BHEL's Technical Specification. Any deviations from the specification are to be furnished separately as "Schedule of Deviation". If there is no deviation vendor should indicate "No Deviation".	No deviation/ Deviation quoted	
d. The offer has to be submitted as a Two-part bid i.e. Part-I: Techno-commercial & Part-II: Price bid Note: This confirmation sheet shall be a part of Techno-commercial bid. Price bid shall only contain the quoted price.	Bid submitted in two parts Yes/ No	
e. The tender will be finalized on item-wise basis	Accepted/ Not-accepted	
f. Terms of Payment: Indigenous Supplier (Non-MSME): 100% payment on 90th day from Vehicle/Gate entry date. Indigenous Supplier (Medium Enterprise): 100% payment on 60th day from Vehicle/Gate entry date. Indigenous Supplier (MSE): 100% payment on 45th day from Vehicle/Gate entry date. Suppliers quoting for MSME payment must produce UDYAM registration certificate along with part 1 bid documents.	Accepted/ Not-accepted	
	MSE/ Non-MSE	
	If MSE, mentioned supporting document enclosed in Part-I bid. Yes/ No	
g. Liquidated Damage: Liquidated damages shall be 0.5% of the undelivered portion per week of the delay or part thereof subject to a maximum of 10% of the total order value.	Accepted/ Not-accepted	
h. Inco Terms: Prices shall be quoted on " FIRM PRICE " basis only. F.O.R / Stores, BHEL Trichy	Accepted/ Not-accepted	
i. Validity of Offer: Prices should be valid for 12 months from the date of finalisation of the rate contract or 15 months from the date of part-1 bid opening, whichever is earlier.	Accepted/ Not-accepted	
j. Delivery period: Delivery period should be 10 weeks from the date of purchase order.	Accepted/ Not-accepted	
k. Guarantee Clause: The vendor shall give a guarantee for the performance of his supplies for a period of eighteen months from the date of dispatch or twelve months from the date of commissioning, whichever is earlier. Any warranty replacement during warranty period shall be supplied free of charge on FOR site basis/destination specified by BHEL	Accepted/ Not-accepted	
l. Reverse auction: Reverse Auction (RA) is not applicable for this enquiry.		



BHARAT HEAVY ELECTRICALS LTD

VALVES PURCHASE

Trichy - 620 014. India

CONFIRMATION TO TERMS AND CONDITIONS

Enquiry Reference: RCSIGV2443

<u>TERMS & CONDITION</u>	<u>VENDOR's response</u> (strike-off, whichever is not applicable)	<u>VENDOR REMARKS</u> <u>(if any)</u>
m. Counter-offering: Counter-offer is not applicable for this enquiry.		
n. Local content certificate: Supplier shall submit the local content certificate with self-declaration in part 1 bid documents. (Use format in NIT documents)	Attached/ Not attached	
o. Performance Bank Guarantee: Performance Bank Guarantee is not applicable for this enquiry .		
p. Integrity Pact Integrity pact is not applicable for this enquiry. (Use format in NIT documents)		
q. Collection of rejected items: Items rejected during the course of this RC shall be collected by the supplier from time to time by producing applicable credit note at BHEL Stores. Subsequently, replacements for rejected items and quantities shall be supplied.	Accepted/ Not-accepted	
r. Sequential supply: Purchase orders placed shall be executed chronologically in the order of date of issue i.e., Oldest PO shall be executed first.	Accepted/ Not-accepted	
s. Declaration: It is hereby declared that all the terms and conditions of this rate contract enquiry, as mentioned in General Terms & Conditions in the NIT, have been read, understood and our acceptance without any deviation to the same is confirmed.	Confirmed/ Not confirmed	
Documents/ Records to be submitted along with Part-I bid		
t. Signed and sealed "SCOPE OF SUPPLY" format	Attached/ Not attached	
u. Signed and sealed "SCHEDULE OF DEVIATION" format. If there is no deviation Bidder should mandatorily indicate "No Deviation" in the "SCHEDULE OF DEVIATION" format.	Attached/ Not attached	
v. Signed and sealed applicable drawings, Specification and TDC of items quoted.	Attached/ Not attached	
w. Local content declaration in bidder's letter pad, as per attached BHEL format.	Attached/ Not attached	
x. Signed and sealed General terms and conditions, Documents supporting to PQR condition and udyam certificate.	Attached/ Not attached	
y. Details of the bidder's authorised person for contacting w.r.t this tender		
Name:		
Designation:		
e-mail id:		
Mobile Number:		

Supplier's Seal and Sign with date

Schedule of Deviation

Item No	Material Code	Material Description	Drawing No/Rev No	TDC No/Spec.Rev No	Quantity (Nos)	Delivery Period from PO date	Technical deviation, if any
1	964532430000	SOFT IRON GASKET-W016	2VW01615634/02	TDC:5:158/00	100	10 Weeks	
2	964532400000	SOFT IRON GASKET SI.PL-W007	2VW00715634/02	TDC:5:158/00	600	10 Weeks	
3	964532410000	SOFT IRON GASKET-W010	2VW01015634/02	TDC:5:158/00	120	10 Weeks	
4	964532420000	SOFT IRON GASKET-W013	2VW01315634/02	TDC:5:158/00	20	10 Weeks	
5	964532440000	SOFT IRON GASKET SI.PL-W019	2VW01915634/02	TDC:5:158/00	20	10 Weeks	
6	964532480000	SOFT IRON GASKET SI.PL-W058	2VW05815634/02	TDC:5:158/00	20	10 Weeks	
7	964532450000	SOFT IRON GASKET(SIL. PL)-W022	2VW02215634/02	TDC:5:158/00	40	10 Weeks	
8	964532460000	SOFT IRON GASKET-W050	2VW05015634/02	TDC:5:158/00	80	10 Weeks	
9	964532470000	SOFT IRON GASKET(SIL. PL)-W054	2VW05415634/02	TDC:5:158/00	80	10 Weeks	
10	964532490000	SOFT IRON GASKET SI.PL-W062	2VW06215634/02	TDC:5:158/00	40	10 Weeks	
11	964532500000	SOFT IRON GASKET-W066	2VW06615634/02	TDC:5:158/00	20	10 Weeks	
12	964532530000	SOFT IRON GASKET SI.PL-W078	2VW07815634/02	TDC:5:158/00	40	10 Weeks	
13	964532540000	SOFT IRON GASKET SIL.PL-G005	2VG00515634/02	TDC:5:158/00	400	10 Weeks	
14	964532550000	SOFT IRON GASKET(SIL.PL.)-G008	2VG00815634/02	TDC:5:158/00	200	10 Weeks	
15	964532560000	SOFT IRON GASKET-G014	2VG01415634/02	TDC:5:158/00	140	10 Weeks	
16	964532570000	SOFT IRON GASKET-L007	2VL00715634/02	TDC:5:158/00	40	10 Weeks	
17	964532580000	SOFT IRON GASKET SI.PL-L010	2VL01015634/02	TDC:5:158/00	20	10 Weeks	
18	964532590000	SOFT IRON GASKET SI.PL-L030	2VL03015634/02	TDC:5:158/00	40	10 Weeks	
19	964532600000	SOFT IRON GASKET SI.PL-L034	2VL03415634/02	TDC:5:158/00	40	10 Weeks	
20	964532610000	SOFT IRON GASKET SI.PL-W114	2VW11415634/02	TDC:5:158/00	60	10 Weeks	
21	964532620000	SOFT IRON GASKET-W118	2VW11815634/02	TDC:5:158/00	20	10 Weeks	
22	964532630000	SOFT IRON GASKET-G042	2VG04215634/02	TDC:5:158/00	300	10 Weeks	
23	964532660000	SOFT IRON GASKET SI.PL-L074	2VL07415634/02	TDC:5:158/00	20	10 Weeks	
24	964532680000	SOFT IRON GASKET SI.PL-W410	2VW41015634/02	TDC:5:158/00	20	10 Weeks	
25	964532690000	SOFT IRON GASKET SI.PL-R066	2VR06615634/02	TDC:5:158/00	40	10 Weeks	
26	964532700000	SOFT IRON GASKET SI.PL-W338	2VW33815634/02	TDC:5:158/00	40	10 Weeks	
27	964532710000	SOFT IRON GASKET SI.PL-W354	2VW35415634/02	TDC:5:158/00	20	10 Weeks	
28	964532740000	SOFT IRON GASKET-L004	3VL00420823/01	TDC:5:158/00	200	10 Weeks	

Schedule of Deviation

Item No	Material Code	Material Description	Drawing No/Rev No	TDC No/Spec.Rev No	Quantity (Nos)	Delivery Period from PO date	Technical deviation, if any
29	964532750000	SOFT IRON GASKET-L007	3VL00720823/01	TDC:5:158/00	40	10 Weeks	
30	964532760000	SOFT IRON GASKET-L010	3VL01020823/01	TDC:5:158/00	40	10 Weeks	
31	964532770000	SOFT IRON GASKET-L026	3VL02620823/01	TDC:5:158/00	140	10 Weeks	
32	964532780000	SOFT IRON GASKET-L034	3VL03420823/01	TDC:5:158/00	60	10 Weeks	
33	964532820000	SOFT IRON GASKET-L170	3VL17020823/01	TDC:5:158/00	20	10 Weeks	
34	964532790000	SOFT IRON GASKET-L130	3VL13020823/01	TDC:5:158/00	20	10 Weeks	
35	964532810000	SOFT IRON GASKET(SI.PL.)-L178	3VL17820823/01	TDC:5:158/00	40	10 Weeks	
36	964532830000	SOFT IRON GASKET-L154	3VL15420824/01	TDC:5:158/00	300	10 Weeks	
37	964532840000	SOFT IRON GASKET-L130	3VL13020824/01	TDC:5:158/00	20	10 Weeks	
38	964532870000	SOFT IRON GASKET-L090	3VL09020824/01	TDC:5:158/00	40	10 Weeks	
39	964532880000	SOFT IRON GASKET-L178	3VL17820824/01	TDC:5:158/00	20	10 Weeks	
40	964532890000	SOFT IRON GASKET-L170	3VL17020824/01	TDC:5:158/00	20	10 Weeks	
41	964532900000	SOFT IRON GASKET-W442	3VW44220824/01	TDC:5:158/00	20	10 Weeks	
42	964532910000	SOFT IRON GASKET-W458	3VW45820824/01	TDC:5:158/00	20	10 Weeks	
43	964534520000	GASKET (SILVER PLATED)-W730	3VW73021095/00	TDC:5:158/00	20	10 Weeks	
44	964563270000	SELFSEALING RING-2700	3V270017027/01	TDC:5:158/00	20	10 Weeks	
45	964665740000	SOFT IRON GASKET (SPINDLE)-LP01	4VLP0119784/00	SPEC:CV:0015/00	100	10 Weeks	
46	964665750000	SOFT IRON GASKET-LP01	4VLP0119785/00	SPEC:CV:0015/00	100	10 Weeks	

Seal and Signature of authorized signatory with date



BHARAT HEAVY ELECTRICALS LTD

VALVES PURCHASE

Trichy - 620 014, India

GENERAL TERMS AND CONDITIONS

Enquiry Reference: RCSIGV2443

1. QUOTATIONS:

- a. **BID system:** Offers are invited in any one of the below formats. The No. of bids to be submitted is mentioned in "Confirmation to the Terms and Conditions" attached.
- Two part bid: The offers are invited in Two part bid system (Part I will be Techno-commercial bid and part II will be Price Bid). Techno-commercially suitable vendors alone will be intimated for price bid opening.
 - Single part bid: The offers are invited in Single part bid system (Price Bid alone). The vendor shall confirm to all of BHEL's technical & commercial conditions.

b. Submission of offer:

- Offer called through e-Procurement mode: The bidder shall submit the bid online in BHEL e-Procurement portal at

<https://eprocurebhel.co.in/nicgep/app>

The bidder would be required to register on the above e-procurement portal for submitting their bids. Offers through email and hardcopy are not acceptable.

- ~~Offer called through Non e-Procurement mode:~~ Each part of offer should be sent in a double cover separately and the same should be sealed and super scribed with details such as enquiry reference, name of the vendor, item of supply and due date of opening. Two or more quotations should not be sent in one cover. Price Bid should contain only "Price per unit" for each type. Offer should be sent to the below mentioned address:

The Tender Opening Cell / Valves
Room No.-26, Building-24
Bharat Heavy Electricals Limited
Tiruchirappalli-620014, Tamil Nadu, India
Or
Email ID: tender_cell@bhel.in

- ~~Late offers:~~ Offer received after 2.00 pm on due date will be considered as Late offers. Late offers will not be considered under any circumstance.
- Regulations:** Offers should be free from correction and erasures. Corrections if any must be attested. All amounts shall be indicated both in words as well as figures. In case of a difference between the amount quoted in words and figures, the amount quoted in words shall prevail.
- PVC:** Price Variation clause not acceptable. Prices should be firm.
- Catalogue:** Manufacturer's name, Trade Mark or Patent No. if any should be specified. Illustrative leaflets giving technical particulars are required along with quotation.
- Samples:** Samples should be submitted separately, if specially requested in tender, before the due date of the enquiry. They should be clearly marked with the enquiry reference and date on the enclosing cover to facilitate identification.
- GST Number:** GST registration number, HSN number (Item wise) with applicable taxes should be mentioned in the offer. If the vendor is not GST registered the offer is liable for rejection.
- Deviation.** Any deviations from the specification are to be furnished separately as "Schedule of Deviation". If there is no deviation, vendor should indicate "No Deviation" in the offer.
- Confirmation:** Confirmation for compliance is to be given in the offer for all the techno commercial conditions specified in the tender.



BHARAT HEAVY ELECTRICALS LTD

VALVES PURCHASE

Trichy - 620 014, India

GENERAL TERMS AND CONDITIONS

Enquiry Reference: RCSIGV2443

2. COMMERCIAL TERMS & CONDITIONS:

a. Terms of Payment:

If the materials are receivable at BHEL Stores, Trichy:

Indigenous Supplier (Non-MSME):

Payment term is 100% direct Payment on 90th day from day from Vehicle/Gate entry date.

(or)

Payment term is 100% direct payment on 90th day from Vehicle/Gate entry date and against 10% PBG valid for the warranty period. (if PBG is applicable)

Indigenous Supplier (Medium Enterprise):

Payment term is 100% direct Payment on 60th day from day from Vehicle/Gate entry date.

(or)

Payment term is 100% direct payment on 60th day from Vehicle/Gate entry date and against 10% PBG valid for the warranty period. (if PBG is applicable)

Indigenous Supplier (MSE): 100% payment on 45th day from Vehicle/Gate entry date

If the materials are receivable at site:

Indigenous Supplier (Non-MSME):

Payment term is 100% direct payment on 90th day from the date of dispatch against site acknowledgement (if PBG is applicable)

(or)

Payment term is 100% direct payment on 90th day from the date of dispatch against site acknowledgement and against 10% PBG valid for the warranty period (if PBG is applicable)

Indigenous Supplier (Medium Enterprise):

Payment term is 100% direct payment on 60th day from the date of dispatch against site acknowledgement (if PBG is applicable)

(or)

Payment term is 100% direct payment on 60th day from the date of dispatch against site acknowledgement and against 10% PBG valid for the warranty period (if PBG is applicable)

Indigenous Supplier (MSE): Payment will be as per MSMED Act, 2006.

100% direct EFT Payment on 45th day from the date of dispatch against site acknowledgement and against 10% PBG valid for the warranty period (if PBG is applicable)

For Foreign Suppliers: Payment term is 100% payment on CAD basis after 60 days from the date of receipt of documents, specified in PO, at BHEL bank. Respective bank charges to respective account.

~~If supplier insists for LC, only Usance LC with 60 days' credit will be opened, one month prior to material readiness, Further loading will be considered @ 1.5% on the offered value. Hence, supplier shall intimate the material readiness accordingly for opening LC. LC validity period will be 90 days and for any extension, applicable charges will be to suppliers account.~~

~~Any deviation in the above payment terms, any other conditions in payment terms or any other payment terms will not be accepted and offers will not be considered.~~



BHARAT HEAVY ELECTRICALS LTD

VALVES PURCHASE

Trichy - 620 014, India

GENERAL TERMS AND CONDITIONS

Enquiry Reference: RCSIGV2443

For New Suppliers: For new suppliers not registered with BHEL, Trichy for the product, payment shall be made 60 days after receipt and acceptance of materials.

~~In case of foreign supplier, first lot of mutually agreed quantities shall be supplied with payment as CAD basis after 60 days from the date of receipt and acceptance of material. If insisted for LC after acceptance of first lot, only usance LC with 60 days' credit will be opened one month prior to material readiness.~~

b. Liquidated Damage:

Liquidated damages shall be 0.5% of the undelivered portion per week of the delay or part thereof subject to a maximum of 10% of the total order value. **Vehicle/Gate entry date** will be reckoned for the purpose of LD calculation.

Any deviation from the above LD clause, loading will be applied to the extent to which it is not agreed by the bidder (at offered value).

c. Delivery Terms:

For Indigenous Suppliers: FOR BHEL Trichy inclusive of freight and insurance

For Foreign Suppliers: CFR/CIF Chennai seaport as per Incoterms 2010.

- d. **Validity of Offer:** Prices should be fixed and should be valid for period as mentioned in the "Confirmation to the Terms and Conditions" attached.
- e. **Delivery period:** Delivery schedule will be as mentioned in the "Confirmation to the Terms and Conditions" attached.
- f. **Guarantee period:** The vendor shall give a guarantee for the performance of his supplies for a period of **eighteen months** from the date of dispatch or **twelve months** from the date of commissioning whichever is earlier.
- g. **Miscellaneous:** Any conditions which might have been quoted by the seller and are in contravention to the terms of PO and which have not been specifically accepted by Purchaser will not be applicable to the contract/PO.
- h. **Performance Bank Guarantee:** If tender calls for Performance Bank Guarantee, vendor should provide a performance bank guarantee (PBG) in BHEL format for 10% of the total Purchase order value valid for warranty/guarantee period with an additional claim period of 2 months. PBG should be issued from list of consortium banks.
- i. **Counter Offering:** If counter offering is applicable for the enquiry, the L1 rates will be counter-offered to other eligible vendors as per below points
- In case there are only two qualified offers for any item, the L1 rate will be counter-offered to the L2 vendor.
 - In case of more than two qualified offers for any item, the L1 rates will be counter-offered to maximum (n-1) vendors (where 'n' is the no. of techno-commercially qualified vendors) or the no. of vendors required (as mentioned in the "Confirmation to the Terms and Conditions" attached), whichever is lower.
 - In case a lower ranked vendor does not accept the counter-offered rates, the rates may be offered to next higher ranked vendor.
 - The manner of splitting of the enquiry quantity across L1 and counter-offer accepted vendors will be as per the ratios mentioned in the "Confirmation to the Terms and Conditions" attached.

3. COMPLIANCE / ACCEPTANCE REQUIRED FOR FOLLOWING POINTS TO ENSURE INPUT TAX CREDIT

- a. Response to Tenders for Indigenous supplier/Vendor will be entertained only if the vendor has a valid GST registration No (GSTIN) which should be clearly mentioned in the offer. If the Vendor is exempted from GST registration, a declaration with due supporting documents need to be furnished for considering the offer.



BHARAT HEAVY ELECTRICALS LTD

VALVES PURCHASE

Trichy - 620 014, India

GENERAL TERMS AND CONDITIONS

Enquiry Reference: RCSIGV2443

Vendor under composition scheme should declare that he is a composition Vendor supported by the screen shot taken from GST portal. The dealer has to submit necessary documents if there is any change in status under GST.

- b.** Supplier shall mention their GSTIN in all their invoices (incl. credit Notes, Debit Notes) and invoices shall be in the format as specified/prescribed under GST laws. Invoices shall necessarily contain Invoice number (in case of multiple numbering system is being followed for billing like SAP invoice no, commercial invoice no etc., then the Invoice No. which is linked/uploaded in GSTN network shall be clearly indicated), Billed to party (with GSTIN) & Shipped to party details, item description as per PO, Quantity, Rate, Value, applicable taxes with nomenclature (like IGST, SGST, CGST & UTGST) separately, HSN/ SAC Code, Place of Supply etc.
- c.** Invoices will be processed only upon completion of statutory requirement and further subject to following:
 - i.** Vendor declaring such invoice in Form GST ANX-1
 - ii.** Receipt of Goods or Services and Tax invoice by BHEL
- d.** All invoices shall bear the HSN Code for each item separately (Harmonized System of Nomenclature)/ SAC code (Services Accounting Code).
- e.** As the continuous uploading of tax invoices in GSTN portal (in GST ANX-1) is available for all (i.e. both Small & Large) tax payers under proposed new GST Return System, all invoice raised on BHEL may be uploaded immediately in GST portal on despatch of material /rendering of services. The supplier shall ensure availability of Invoice in GST portal before submission of invoice to BHEL. Invoices will be admitted by BHEL only if the invoices are available in GSTN portal (in BHEL's GST ANX-2).
- f.** A declaration to the effect that all invoice particulars are/were uploaded in the GSTN network/ portal & all tax liability as per GST rules and regulations have been and will be discharged, shall be mentioned in the invoice. If not mentioned in the invoice, a separate declaration shall be submitted as per the requirement of BHEL.
- g.** All documents like Test Certificate, LR copy, any other document mentioned in PO, shall be sent along with the vehicle/consignment. For all consignments received within the calendar month, input credit will be availed within that month in line with monthly returns filing cycle. In case of any discrepancy in the document or non-submission of documents mentioned in the PO, then BHEL will not be able to accept or account the material, in such case availing of tax credit will be deferred to next month or so.
- h.** In case of discrepancy in the data uploaded by the supplier in the GSTN portal or in case of any shortages or rejection in the supply, then BHEL will not be able to avail the tax credit and will notify the supplier of the same. Supplier has to rectify the data discrepancy in the GSTN portal or issue credit note or debit note (details also to be uploaded in GSTN portal) for the shortages or rejections in the supplies or additional claims, within the calendar month informed by BHEL.
- i.** In cases where invoice details have been uploaded by the vendor but failed to remit the GST amount to GST Department (Form PMT-08 or Form GST RET-01 to be submitted) within stipulated time, then GST paid on the invoices pertaining to the month for which GST return not filed by the vendor will be recovered from the vendor along with the applicable interest (currently 24% p.a) and all subsequent bills of the vendor will not be processed till filing of the GST return by the vendor.
- j.** Under GST regime, BHEL has to discharge GST liability on LD recovered from suppliers/contractors. Hence applicable GST shall also be recoverable from suppliers/contractors on LD amount. For this, debit note will be issued by BHEL indicating the respective supply invoice number.
- k.** In case any changes in taxes and duties as per Gov. Notification (including GST), the same shall be applicable from time to time.
- l.** Duplicate copy of the Invoice meant for the transporter should accompany the material as stipulated under CE Rules 52A and 172C OR 57CE.
- m.** TDS on GST shall be applicable as per the GST Act.



BHARAT HEAVY ELECTRICALS LTD

VALVES PURCHASE

Trichy - 620 014, India

GENERAL TERMS AND CONDITIONS

Enquiry Reference: RCSIGV2443

- n. In case GST credit is denied to BHEL due to non-receipt or delayed receipt of goods and/ or tax invoice or expiry of timeline prescribed in GST law for availing such ITC, or any other reasons not attributable to BHEL, GST amount claimed in the invoice shall be disallowed to the vendor.
- o. Where any GST liability arising on BHEL under Reverse Charge (RCM), the vendor has to submit the invoices to BHEL well within the timeline prescribed in GST Law, to enable BHEL to discharge the GST liability. If there is a delay in submission of invoice by the vendor resulting in delayed payment of GST by BHEL along with Interest, then such Interest payable or paid shall be recovered from the vendor.
- p. GST TDS will be deducted as per Section 51 of CGST Act 2017 and in line with Notification 50/2018 – Central Tax dated 13.09.2018. GST TDS certificate which will be generated in GST portal subsequent to vendor accepting the TDS deduction in the GST portal, will be issued to the vendor.

4. SPECIAL PROVISIONS FOR MICRO AND SMALL ENTERPRISES (MSE):

- a. 25% of the tendered quantity is earmarked for MSE suppliers (**Manufacturers only**) in this tender.
- b. If L1 vendor (or) Counter offer accepted vendor/s is from a Micro / Small enterprise which put together covers 25% of the total tendered quantum, the 25% earmarking provision is not applicable.
- c. Out of the 25% tendered quantity reserved for MSE suppliers, 6.25% shall be earmarked for procurement from MSE owned by SC / ST entrepreneurs. In the event of failure of such Micro and Small enterprises to participate in the tender process or meet the tender requirements and the L1 price, the 6.25% sub-target for procurement ear-marked MSE owned by SC / ST entrepreneurs shall be met with other MSE enterprise/s.
- d. 3% reservation for women owned MSEs within the above mentioned 25% reservation. In the event of failure of such Micro and Small enterprises to participate in the tender process or meet the tender requirements and the L1 price, the 3% sub-target for procurement ear-marked MSE owned by women entrepreneurs shall be met with other MSE enterprise/s. The definition for MSEs owned by Women Entrepreneurs is clarified as:
 - i. In case of proprietary MSE, proprietor shall be woman.
 - ii. In case of partnership MSE, the women partners shall be holding at least 51% share in the unit.
 - iii. In case of private limited companies, at least 51% share shall be held by the women promoters.
- e. In case MSE vendor participating in the tender quotes within the price band of LI +15%, they will be allowed to supply the portion of the requirement subject to acceptance of LI price by MSE vendor. In case of more than one such MSE, the supply shall be shared proportionately, provided the available quantum can be split.
- f. In a tender where both MSE and Non-MSE Vendors have participated and non-MSE Vendor has become the lowest bidder and the quantum envisaged in the tender cannot be split, then the MSE vendor will be given preference for ordering the 100% quantum provided the MSE vendor quoted price is within L1 + 15%, and if the MSE vendor accepts the L1 rate.
- g. MSE suppliers can avail the intended benefits only if,
The vendor submits along with offer, a copy of the UDYAM certificate (Micro or small).
Definitions of MSEs owned by SC/ST is under:
 - i. In case of proprietorship firm, proprietor must be SC/ST.
 - ii. In case of partnership firm, the SC/ST partners must be holding at least 51% shares in the unit.
 - iii. In case of private limited companies, at least 51% share must be held by SC/ST promoters.
 - iv. The caste/Tribe/Community certificate issued by the following authorities in the prescribed form for SCs/STs can be considered.
- h. Authorized to Issue SC/ST certificate:
 - i. District Magistrate/Additional District Magistrate/Collector/Deputy commissioner/Additional Deputy Commissioner/Deputy collector/1st class stipendiary magistrate/Sub divisional Magistrate/Taluka Magistrate/Executive magistrate/Extra Assistant commissioner.



BHARAT HEAVY ELECTRICALS LTD

VALVES PURCHASE

Trichy - 620 014, India

GENERAL TERMS AND CONDITIONS

Enquiry Reference: RCSIGV2443

- ii. Chief Presidency magistrate/Additional chief presidency magistrate/Presidency magistrate.
 - iii. Revenue Officer not below the rank of tehsildar.
 - iv. Sub-Divisional officer of the area where the individual and / or his family normally resides.
- i. To avail the benefits of MSE under SC/ST category, the related documents as stated above should be submitted along with tender documents.

5. GENERAL CONDITIONS

- a. The manner of finalization will be as mentioned in the "Confirmation to the Terms and Conditions" attached. Separate orders will be released for each project and documents should be supplied for each order separately.
- b. BHEL reserves the right to reduce the tender quantity and to NOT to order for some or all material based on the changes in project.
- c. BHEL shall have the right to visit vendor works during the execution of contract along with end customer for verifying status, inspection and testing of the material.
- d. BHEL reserves the right to negotiate or re-float the tender in case the quoted prices are not acceptable.
- e. Supplier shall arrange packing to avoid lose or damages during Road Transport, Site handling & Storage.
- f. BHEL reserves the right to reject the offer of a particular bidder due to unsatisfactory past performance in the execution of a contract at any of BHEL projects / units.
- g. The Drawings and Technical documents given in this enquiry are the sole property of BHEL. This should not be misused in any form.
- h. Purchase Order, PO Item serial number, Material code, Quantity should be clearly marked on the packing
- i. Confirmation for compliance is to be given in the offer for all the conditions specified above and to the respective Purchase Specification.
- j. The bidder along with its associate/collaborators/sub-contractors/sub-vendors/consultants/service providers shall strictly adhere to BHEL fraud prevention policy (refer www.bhel.com) and shall immediately bring to the notice of the BHEL management about any fraud or suspected fraud as soon as it comes to their notice.
- k. Preference to Make In India products (For bids < 200 Crore): Preference shall be given to Class 1 local supplier as defined in public procurement (Preference to Make in India), Order 2017 as amended from time to time and its subsequent Orders/Notifications issued by concerned Nodal Ministry for specific Goods/Products. The minimum local content to qualify as a Class 1 local supplier is denoted in the bid document. If the bidder wants to avail the Purchase preference, the bidder must upload a certificate from the OEM regarding the percentage of the local content and the details of locations at which the local value addition is made along with their bid, failing which no purchase preference shall be granted. In case the bid value is more than Rs 10 Crore, the declaration relating to percentage of local content shall be certified by the statutory auditor or cost auditor, if the OEM is a company and by a practicing cost accountant or a chartered accountant for OEMs other than companies as per the **Public Procurement (preference to Make-in -India) order 2017 dated 04.06.2020**. Only Class-I and Class-II Local suppliers as per MII order dated 4.6.2020 will be eligible to bid. **Non - Local suppliers as per MII order dated 04.06.2020** are not eligible to participate. However, eligible micro and small enterprises will be allowed to participate. In case Buyer has selected Purchase preference to Micro and Small Enterprises clause in the bid, the same will get precedence over this clause.
- l. The bidder declares that they will not enter into any illegal or undisclosed agreement or understanding, whether formal or informal with other Bidder(s). This applies in particular for prices, specifications, certifications, subsidiary contracts, submission or non-submission of bids or any other actions to restrict



BHARAT HEAVY ELECTRICALS LTD

VALVES PURCHASE

Trichy - 620 014, India

GENERAL TERMS AND CONDITIONS

Enquiry Reference: RCSIGV2443

competitiveness or to introduce cartelization in the bidding process. In case, the Bidder is found having indulged in above activities, suitable action shall be taken by BHEL as per extant policies/ guidelines.

- m. Any change in applicable rates of Tax or any other statutory levies (Direct / Indirect) or any new introduction of any levy by means of statute and its corresponding liability for the deliveries beyond the agreed delivery date for reasons not attributable to BHEL will be to vendors account. BHEL will not reimburse the same and any subsequent claim in this respect will be summarily rejected.

6. DOCUMENTATION:

- a. **With Consignment:** Duplicate for transporter copy, Original Invoice, Packing List, Delivery Challan, O&M manual (if applicable) Material Test Certificate, Test Certificates, Compliance Certificate, Guarantee/Warranty Certificate and other documents mentioned in PO/TDC/Drawing.
- b. **To Purchase:**
- i. FOR BHEL TRICHY case- Original Invoice, Duplicate for transporter copy, Packing list, LWB and Delivery challan, GST declaration as mentioned in point 3c.
- ii. FOR Site case- Original Invoice, Original LWB, Original Packing List, Original IBR documents, Original despatch clearance Certificate and Inspection report, Test certificates as per PO, Original Site Acknowledgment etc.
- c. **Identification:** Material code, Purchase Order, PO item serial number, Unique serial number if any should be provided in all despatch documents, materials and packing clearly.

7. TENDER EVALUATION:

a. Techno-commercial Bid.

- i. All vendors should submit General arrangement drawing, datasheet and C&I diagram (if any) of the offered product
- ii. Point by point technical confirmation of all pages of our technical specifications and commercial conditions are required with your sign and seal along with techno commercial offer.
- iii. Offers from supplier not having technical capability or not agreed for commercial terms, are liable for rejection.

b. Price Bid.

- i. Bidders qualified for part I will be intimated for participating in priced bid opening.
- ii. L1 bidder will be decided based on landed cost for the equipment to BHEL.

Indigenous Vendors

Total Landed cost/rate for each item = FOR Rate in INR (A) + Applicable Taxes (B) + Loading non-acceptance of commercial terms (C) – Applicable input tax credit (D)

A - Indigenous vendors submit offers on Free on Road (FOR), Stores, HPBP BHEL Trichy in INR.

B - Applicable GST and any other charges quoted by indigenous vendors will be added to the base price.

C - Loading for non-acceptance of payment terms, delivery schedule & liquidated damages (LD) will be added to the F.O.R. value for arriving the landed rate.

D - However, input tax credit shall be availed for GST, hence the same is excluded for arriving at the landed cost.

Foreign Vendors

Total Landed cost = CFR Rate in INR (A) + Applicable Duties (B) + Incidental Charges (C) + Loading for Container Shipment (D) + Loading for non-acceptance of commercial terms (E)



BHARAT HEAVY ELECTRICALS LTD

VALVES PURCHASE

Trichy - 620 014, India

GENERAL TERMS AND CONDITIONS

Enquiry Reference: RCSIGV2443

A - Foreign vendors to submit offers on CFR (Cost & Freight), Chennai port (LIFO – Liner In; Liner Out) basis per item wise in foreign currency, which will be converted to INR by multiplying with the Exchange rate (SBI TT Selling rate) as on the technical bid opening date. If the date of opening happens to be a bank holiday, then the forex rate as on previous bank (SBI) working day shall be taken.

B - Customs duty, Safe guard duty (as per the notification No 02/2014-Customs (SG) dated 13th August 2014) and antidumping duty (as per the notification No 18/2016-Customs (ADD) dated 17.05.2016) as if applicable will be added to the INR price.

C - Incidental charges will be added to the CFR Value. The incidental charge is inclusive of port handling charges, & freight charges for movement from Chennai port to BHEL, Trichy.

D - In case of shipment through containers, if 14 free days for Container detention is not provided in the offer, a loading of 22% on the freight rate per MT shall be considered by BHEL for arriving at the Total Landed Cost.

E - Loading for non-acceptance of payment terms, delivery schedule & Liquidated Damages (LD) will be added to the CFR value for arriving at the landed cost.

iii. In case of tie for the L1 positions,

- In the course of evaluation, if more than one bidder happens to occupy L1 status, effective L1 will be decided by soliciting discounts from respective L1 bidders.
- In case more than one bidder happens to occupy the L1 status even after soliciting discounts, the L1 bidder shall be decided by a toss/draw of lots, in the presence of the respective L1 bidders(s) or their representative(s).
- Ranking will be done accordingly, BHEL's decision in such situation shall be final and binding.

iv. If counter-offer is applicable and before counter offer process, if there is tie for ranking position other than L1 in respective enquiry items, then Lot shall be done to break the tie. Based on the outcome of LOT, subsequent tender ranking will be revised. Load distribution shall be based on revised ranking. The LOT process to break tie in tender ranking will be based on random number generation in MS-Excel sheet.

Tie breaking procedure has been explained below with an example:

There is an item (item sl. no. 210) for which tie breaking has to be conducted. Hence, the lot will be based on random number generation in MS-Excel sheet.

- Item wise excel sheet in which all ranks for which tie is present shall be opened.
- Random number shall be generated against each entry in the excel sheet. Once random number is generated, the values will be frozen against each entry.
- The rank order shall be sorted in the following manner.
Sorting -> 1. Item -> 2. Actual rank -> 3. Random number wise (from lowest to highest).
Once sorting is done, each vendor shall be ranked as per the sorting order.

• **Illustration:**

Step-1: Before Sorting:

Item No.	Vendor code	ORIGINAL Rank before CO
210	A	L01
210	B	L02
210	C	L03
210	D	L03



BHARAT HEAVY ELECTRICALS LTD

VALVES PURCHASE

Trichy - 620 014, India

GENERAL TERMS AND CONDITIONS

Enquiry Reference: RCSIGV2443

210	E	L04
210	F	L05
210	G	L05
210	H	L06

Step-2: After random number generation

Item No.	Vendor code	ORIGINAL Rank before CO	Random Number
210	A	L01	0.639156
210	B	L02	0.931402
210	C	L03	0.560449
210	D	L03	0.507298
210	E	L04	0.621819
210	F	L05	0.620683
210	G	L05	0.504936
210	H	L06	0.793407

Step-3: Final sorting and revised ranking:

Item No.	Vendor code	ORIGINAL Rank before CO	Random Number	Final Revised Rank
210	A	L01	0.639156	L01
210	B	L02	0.931402	L02
210	D	L03	0.507298	L03
210	C	L03	0.560449	L04
210	E	L04	0.621819	L05
210	G	L05	0.504936	L06
210	F	L05	0.620683	L07
210	H	L06	0.793407	L08

Final revised ranking shall be intimated to vendors. Final revised ranking shall be worked out based on the result of tie-breaking and counter offering process shall be based on the final revised ranking.

L1 rate shall be counter offered to eligible Vendors in respective enquiry items in order of the distinct ranking arrived after tie-breaking process has been concluded.

8. Reverse Auction

"BHEL shall be resorting to Reverse Auction (RA) (Guidelines as available on www.bhel.com) for this tender. RA shall be conducted among the techno-commercially qualified bidders.

Price bids of all techno-commercially qualified bidders shall be opened and same shall be considered for RA. In case any bidder(s) do(es) not participate in online Reverse Auction, their sealed envelope price bid along with applicable loading, if any, shall be considered for ranking."

Reverse Auction Process:



BHARAT HEAVY ELECTRICALS LTD

VALVES PURCHASE

Trichy - 620 014, India

GENERAL TERMS AND CONDITIONS

Enquiry Reference: RCSIGV2443

Reverse Auction will be conducted if two or more bidders are techno-commercially qualified. In case of two or three qualified bidders, there shall be no elimination of H1 bidder (whose quote is highest in sealed envelope price bid). In case of four qualified bidders, the H1 bidder shall be eliminated whereas in case of five qualified bidders, H1 & H2 bidders shall be eliminated. However, in case of six or more qualified bidders are available, RA would be conducted amongst first 50% of the bidders arranged in the order of prices from lowest to highest. Number of bidders eligible for participating in RA would be rounded off to next higher integer value if number of qualified bidders is odd (e.g. if 7 bids are qualified, then RA will be conducted amongst lowest four bidders). However, there will be no elimination of qualified bidders who are MSE or qualifying under PPP-MII, Order 2017, provided their bids are within their respective margin of purchase preference {presently 15% for MSEs and 20% for PPP-MII, or as amended from time to time}.

In case of multiple H1 bidders, all H1 bidders (except MSEs and bidders qualifying under PPP-MII, Order 2017, who are within the margin of purchase preference) shall be removed provided minimum two bidders remain in fray, else no H1 removal.

9. ARBITRATION & CONCILIATION:

Except as provided elsewhere in this Contract, in case amicable settlement is not reached between the Parties, in respect of any dispute or difference; arising out of the formation, breach, termination, validity or execution of the Contract; or, the respective rights and liabilities of the Parties; or, in relation to interpretation of any provision of the Contract; or, in any manner touching upon the Contract, then, either Party may, by a notice in writing to the other Party refer such dispute or difference to the sole arbitration of an arbitrator appointed by Head of the BHEL, Trichy.

The Arbitrator shall pass a reasoned award and the award of the Arbitrator shall be final and binding upon the Parties.

Subject as aforesaid, the provisions of Arbitration and Conciliation Act 1996 (India) or statutory modifications or re-enactments thereof and the rules made thereunder and for the time being in force shall apply to the arbitration proceedings under this clause. The seat of arbitration shall be at BHEL premises, Trichy.

The cost of arbitration shall be borne as per the award of the Arbitrator.

Subject to the arbitration in terms of Clause above, the Courts at TRICHY shall have exclusive jurisdiction over any matter arising out of or in connection with this Contract.

Notwithstanding the existence or any dispute or differences and/or reference for the arbitration, the Contractor shall proceed with and continue without hindrance the performance of its obligations under this Contract with due diligence and expedition in a professional manner except where the Contract has been terminated by either Party in terms of this Contract.

In case of Contract with Public Sector Enterprise (PSE) or a Government Department, the following shall be applicable:

In the event of any dispute or difference relating to the interpretation and application of the provisions of the Contract, such dispute or difference shall be referred by either Party for arbitration to the sole arbitrator in the Department of Public Enterprises to be nominated by the Secretary to the Government of India in-charge of the Department of Public Enterprises. The Arbitration and Conciliation Act, 1996 shall not be applicable to arbitration under this clause. The award of the arbitrator shall be binding upon the Parties to the dispute, provided, however, any Party aggrieved by such award may make further reference for setting aside or revision of the award to the Law Secretary, Department of Legal Affairs, Ministry of Law and Justice, Government of India. Upon such reference the dispute shall be decided by the Law Secretary or the Special Secretary or Additional Secretary when so authorized by the Law Secretary, whose decision shall bind the



BHARAT HEAVY ELECTRICALS LTD

VALVES PURCHASE

Trichy - 620 014, India

GENERAL TERMS AND CONDITIONS

Enquiry Reference: RCSIGV2443

Parties hereto finally and conclusively. The Parties to the dispute will share equally the cost of arbitration as intimated by the Arbitrator.

10. IMPORTANT INFORMATION FOR FOREIGN SUPPLIERS:

- a. Port of loading should be indicated in the offer without fail.
- b. Port of discharge should be Chennai Sea/Air Port, India.
- c. The preferred shipment mode "Containerized Cargo or Break Bulk" shall be specified clearly in the offer.
- d. **In case of CFR INCO TERMS - CONTAINERIZED CARGO**
 - i. In case of CFR terms, moved through CONTAINERS (Suppliers should clearly specify this in their offer) it would be presumed by BHEL that the freight charges quoted is on LILO (LINER IN LINER OUT) basis including extra charges, if any, like Container Imbalance Charges, Trade Imbalance charges or any other charges payable to the Liner. No other charges other than the quoted Freight rate will be paid by BHEL excepting applicable Terminal Handling Charges, Container cleaning Charges, DO charges to Shipping Liner at Discharge Port. 14 FREE DAYS for Container detention shall be provided. If any deviation is taken by Tenderer, a loading of 22% on the freight rate per MT shall be considered by BHEL for arriving at the Total Landed Cost.
 - ii. In case of shipment through Containers on CFR basis, the BL should bear the endorsement that "14 free days for Container Detention is applicable".
- e. **In case of CFR INCO TERMS - BREAKBULK CARGO:** In case of CFR terms, moved through BREAK BULK BASIS (Suppliers should clearly specify this in their offer) it would be presumed by BHEL that the freight charges quoted is on LILO (LINER IN LINER OUT) basis. The materials will be Custom cleared from Port itself.
 - i. The Indian Customs imposed, a penalty on late filing of Bill of Entries (Air/Sea Shipments) by the importer. The maximum free time allowed is 24 hrs from the time of arrival of cargo at final port of discharge. Rs.5000/- per day (for Initial 03 days) & Rs.10000/- per day (thereafter)
 - ii. The vendor should furnish the Non-Negotiable Documents (Air Way Bill/Bill of Lading, Commercial Invoice, Packing List, and Certificate of Origin) either by email or post/courier to BHEL well before the landing of cargo at final port of discharge.
 - iii. Vendor will be held responsible for the penalty arises against the late filing of Bill of entry due to:
 - a. Non availability of Non-Negotiable Documents (NNDs) before the cargo arrival
 - b. Discrepancy in documents
 - c. Short landing of Consignments (For shipments on CFR/CPT/CIF/CIP – Chennai Port)
 - iv. All the shipments for the contracts (POs) finalized on CFR -Chennai Port basis
 - a. Delivery Orders involving multiple agencies like liners/freight forwarders are not allowed. There must be a single agency office at the final discharge Port (Chennai) for issuing the Delivery Order to BHEL.
 - b. The detention/demurrage charges arise due to the delay in collection of Delivery Orders from multiple agencies of liner/freight forwarder also whose offices are not at available Chennai, the same amount will be deducted from Vendor's bills only.
 - c. Apart from the normal charges like Terminal Handling Charges, Container cleaning Charges, Delivery Order Charges at final port of discharge no other charges will be borne by BHEL.
 - d. The liner/freight forwarders should be properly communicated by the Vendor for not to claim such charges for issuing Delivery Order. If the liner/freight forwarder claims such charges in their invoices, the same amount will be deducted from the Vendor bills without any prior intimation in order to avoid the delay in Customs clearance. The likely additional/hidden costs or charges are:
 - i. CIC - Container Imbalance Charges/Surcharges
 - ii. EIC - Equipment Imbalance Charge/Surcharges
 - iii. CAF - Container/Currency Adjustment Factor
 - iv. BAF - Bunker adjustment Factor



BHARAT HEAVY ELECTRICALS LTD

VALVES PURCHASE

Trichy - 620 014, India

GENERAL TERMS AND CONDITIONS

Enquiry Reference: RCSIGV2443

- v. RDS - Rupee Depreciation Surcharge
- vi. CDS - Currency Depreciation Surcharge

f. Transport Conditions for Import:

The Original Documents (Bill of Lading, Invoice, Packing List, Certificate of Origin & Test Certificate) shall reach BHEL well in advance before the vessel arrival. The soft copies of the above shall be forwarded to BHEL immediately after shipment.

- i. In the event of delayed submission of documents by the supplier, an amount up to 5% of the invoice value will be retained towards demurrage & other charges and the difference if any between actual charges and recovery will be settled separately through supplementary invoice.
- ii. In such cases, the Supplier shall authorize the Steamer / Shipping agent / transporter to freely release the consignment to BHEL by providing a "Surrender Bill of Lading".
- iii. Otherwise, No-objection Certificate shall be issued to the Liner, authorizing BHEL to get the Delivery Order without producing the Original Bill of Lading.
- iv. This is required to ensure avoidance of demurrage at Chennai Sea-port that may arise in case of delayed presentation of documents by the Seller.

Following details to be endorsed in OBL

- i. Import & Export Code (IEC) of importer: 0588138690
- ii. GST Identification No (GSTIN) of importer: 33AAACB4146P2ZL
- iii. Official email id of importer: sivabala@bhel.in ; siyama@bhel.in

d. Indian Agent & Agency commission:

- i. An Indian Agent can represent / submit offer of only one original equipment manufacturer (OEM) against a particular Tender. If any Indian Agent represents two or more than one OEM against the same tender, then the Offer will be rejected.
- ii. The CFR - Cost and Freight Chennai Sea Port, price quoted by the Foreign Bidder shall also include the Agency commission. The bidder shall furnish authenticated copy of the Agency Agreement detailing the precise relationship between them and their mutual interest in the business so as to consider the offer of the Indian Agent for the indigenous portion of the supply. For the main equipment, the offer should be from the Principal / OEM. The bidders have to furnish the original Authorization Letter for the Indian Agent along with the Techno-Commercial Offer.

11. INTEGRITY PACT (IP)

- a. IP is a tool to ensure that activities and transactions between Company and its Bidders/Contractors are handled in a fair, transparent and corruption free manner. Following Independent External Monitors (IEMs) on the present panel have been appointed by BHEL with the approval of CVC to oversee implementation of IP in BHEL.

	IEM	Email
	Shri Otem Dai, IAS (Retd.)	iem1@bhel.in
	Shri Bishwamitra Pandey, IRAS (Retd.)	iem2@bhel.in
	Shri Mukesh Mittal, IRS (Retd.)	iem3@bhel.in

- b. If IP is applicable for the enquiry, the IP as enclosed with the tender is to be submitted (duly signed by authorized signatory) along with the techno-commercial bid (Part-I, in case of two/three part bid). Only those bidders who have entered into such an IP with BHEL would be competent to participate in the bidding. In other words, entering into this pact would be a preliminary qualification.



BHARAT HEAVY ELECTRICALS LTD

VALVES PURCHASE

Trichy - 620 014, India

GENERAL TERMS AND CONDITIONS

Enquiry Reference: RCSIGV2443

c. Please refer Section-8 of the IP for Roles and Responsibilities of IEMs. In case of any complaint arising out of the tendering process, the matter may be referred to any of the above IEM(s). All correspondence with the IEMs shall be done through email only.

d. Note:

No routine correspondence shall be addressed to the IEM (phone/post/email) regarding the clarifications, time extensions or any other administrative queries etc. on the tender issued. All such clarifications / issues shall be addressed directly to the tender issuing (procurement) department's officials whose contact details are provided below

(1)

B Rajendra Prasad Reddy

Dy Manager

Valves Purchase

24 Building, 3rd Floor,

BHEL, Trichy-620014

+91 431 2577813

bppreddy@bhel.in

(2)

Ajay Kumar Gupta

AGM

Valves Purchase

24 Building, 3rd Floor,

BHEL, Trichy-620014

+91 431 2578156

ajaykumar.gupta@bhel.in

12. BHEL Fraud Prevention Policy

- a. The bidder along with its associate/collaborators/sub-contractors/sub-vendors/consultants/ service providers shall strictly adhere to BHEL fraud prevention policy and shall immediately bring to the notice of the BHEL management about any fraud or suspected fraud as soon as it comes to their notice.
- b. Please refer to <https://www.bhel.com/bhel-fraud-prevention-policy-0>

13. Conflict of interest among bidders:

A bidder shall not have a conflict of interest with other bidders. Such conflict of interest can lead to anti-competitive practices to the detriment of Procuring Entity's interests. ***The bidder found to have a conflict of interest shall be disqualified.*** A bidder may be considered to have a conflict of interest with one or more parties in this bidding process, if:

- a) they have controlling partner (s) in common; **or**
- b) they receive or have received any direct or indirect subsidy/ financial stake from any of them; **or**
- c) they have the same legal representative/agent for purposes of this bid; **or**
- d) they have relationship with each other, directly or through common third parties, that puts them in a position to have access to information about or influence on the bid of another Bidder; **or**
- e) Bidder participates in more than one bid in this bidding process. Participation by a Bidder in more than one Bid will result in the disqualification of all bids in which the parties are involved. However, this does not limit the inclusion of the components/ sub-assembly/ Assemblies from one bidding manufacturer in more than one bid; **or**



BHARAT HEAVY ELECTRICALS LTD

VALVES PURCHASE

Trichy - 620 014, India

GENERAL TERMS AND CONDITIONS

Enquiry Reference: RCSIGV2443

- f) In cases of agents quoting in offshore procurements, on behalf of their principal manufacturers, one agent cannot represent two manufacturers or quote on their behalf in a particular tender enquiry. One manufacturer can also authorise only one agent/dealer. There can be only one bid from the following:
1. The principal manufacturer directly or through one Indian agent on his behalf; and
 2. Indian/foreign agent on behalf of only one principal; **or**
- g) A Bidder or any of its affiliates participated as a consultant in the preparation of the design or technical specifications of the contract that is the subject of the Bid; **or**
- h) In case of a holding company having more than one independently manufacturing units, or more than one unit having common business ownership/management, only one unit should quote. Similar restrictions would apply to closely related sister companies. Bidders must proactively declare such sister/ common business/ management units in same/ similar line of business.

14. Breach of contract, Remedies and Termination:

- a) In case of breach of contract, wherever the value of security instruments like performance bank guarantee available with BHEL against the said contract is 10% of the contract value or more, such security instruments to the extent of 10% contract value will be encashed.
- b) In case the value of the security instruments available is less than 10% of the contract value, the balance amount will be recovered in all or any of the following manners:
- i. from dues available in the form of Bills payable to defaulted supplier against the same contract.
 - ii. from the dues payable to defaulted supplier against other contracts in the same Region/Unit /any other region/unit.
 - iii. In-case recoveries are not possible with any of the above available options, Legal action shall be initiated for recovery against defaulted
 - iv. supplier.
- c) Further, levy of liquidated damages, debarment, termination, de-scoping, short-closure, etc., will be applied as per provisions of the contract.

15. Suspension of Business Dealings:

Abridged version of extant 'Guidelines for suspension of business dealings with suppliers/ contractors' has now been uploaded on www.bhel.com on "supplier registration page" at the following link: http://www.bhel.com/vender_registration/vender.php (Guidelines for suspension of business dealings with suppliers/ contractors).

Certificate to be provided on vendor letterhead

DECLARATION

In line with Government Public Procurement Order No. P-45021/2/2017-PP (BE-II) dated 28.05.2018, we hereby certify that we, (supplier name) are local supplier meeting requirement of minimum local content (---%) defined in as above orders for the following Enquiry SI Nos of BHEL Enquiry No **RCSIGV2443**

- Mention Enquiry SI Nos –

Details of location at which local value addition will be made is as follows:

.....
.....

By issuing this declaration, we understand and are in acceptance to the following-

- False declarations will be in breach of the Code of Integrity under Rule 175(1)(i)(h) of the General Financial Rules for which a bidder or its successors can be debarred for up to two years as per Rule 151 (iii) of the General Financial Rules along with such other actions as may be permissible under law.
- In case of debarment by any procuring entity for violation of the provisions of the Public Procurement (Preference to Make in India), Order 2017 we shall not be eligible for preference for procurement by any other procuring entity for the duration of the debarment. The debarment for such other procuring entities shall take effect prospectively from the date on which it comes to the notice of other procurement entities, the debarment takes effect prospectively from the date of uploading on the website(s) of The Department of Expenditure, GOI in such a manner that ongoing procurements are not disrupted.
- We undertake the onus of responsibility of submission of appropriately certified documents. We understand that BHEL is not at liability to verify the contents and will not be responsible for the declaration made by us. However, in case BHEL has any reason to doubt the authenticity of the local content, BHEL reserves the right to obtain the complete back up calculations before award of contract and we are liable to submit the same if requested by BHEL. We also understand that our bid is liable for rejection in case we fail to submit the details as requested by BHEL.

Date

Seal and Signature of authorized signatory