



**Bharat Heavy Electricals Limited**  
**ELECTRONICS DIVISION**  
**Mysore Road, Bangalore – 560026**

Ph.080-26998489  
SC&PV – PVE- DEPT.

**NOTICE INVITING TENDERS**

- 1 TENDER NUMBER(RFQ) : EDN: PVSS: WBPDC: 5 MW: CR/02; Dt: 30.04.2019
- 2 NAME OF WORK : Construction of RCC Control Room buildings and other associated works for 5 MW floating Solar PV power plant for WBPDC, SAGARDIGHI at West Bengal”..  
(All listed works shall be Undertaken and executed)
- 3 ESTIMATED COST : **Approximately Rs.93.00 lakhs Plus applicable GST.**
- 4 EARNEST MONEY DEPOSIT : **Rs.1.86 Lakhs (Mandatory for MSME also)**  
**(a) Bidders can submit Rs.1.86 Lakhs EMD through DD/SBI Collect (Please refer point no.: 20 of “Instructions to tenderer” for guideline for payment through SBI Collect).**
- 5 SECURITY DEPOSIT : 50% of SD shall be submitted before start of work; Balance will be recovered from running Bills at a rate of 10%. (SD= 5% of the work order amount); 50% of SD will be released after completion of all the works and remaining 50% after 6 months from the date of completion of all the works.
- 6 COMPLETION TIME : 4 Months.  
(From the date of placement of Order/handing over of the site.)
- 7 LAST DATE AND TIME FOR THE SUBMISSION OF DULY FILLED IN TENDER DOCUMENT : 20.05.2019 Before 01:00 P.M
- 8 PLACE OF SUBMISSION OF TENDER DOCUMENT : Sh. Sreenath M AGM (SC&PV- PCG, M)  
5th Floor, New Engineering Building,  
BHEL- Electronics Division  
Mysore Road, Bangalore -560 026.
- 9 ADDRESS TO BE SUPERSCRIBED ON TENDER ENVELOPE : Sh. Sreenath M AGM (SC&PV- PCG, M)  
5th Floor, New Engineering Building,  
BHEL- Electronics Division  
Mysore Road, Bangalore -560 026.
- 10 DATE AND TIME OF TECHNICAL BID OPENING : 20.05.2019 Before 01:30 P.M

NOTE: The tenderer shall return the dully filled in tender document after affixing signature on all pages and submit.

NIT Issued By

*M. Natesan*

Mowleeswaran Natesan,  
Dy. Manager-Civil, BHEL-EDN

CONTACTOR (SIGN & SEAL)



Bharat Heavy Electricals Ltd  
Electronics Division  
Mysore Road, Bangalore – 560026

**Tender Document for**

**Construction of RCC Control Room buildings and other associated works for 5 MW floating  
Solar PV power plant for WBPDC, SAGARDIGHI at West Bengal**

**TENDER NUMBER RFQ: EDN: PVSS: WBPDC: 5 MW: CR/02; Dt: 30.04.2019**

**TECHNICAL BID DATE OF OPENING: 20-05-2019 (Price bid opening date intimation will be given separately)**

Part – I	Technical cum Commercial Bid	.....	41 Pages
	Unpriced Price Bid	.....	08 Pages
	Technical and General Specification	.....	18 Pages
	BHEL General Conditions of Contract 2019	.....	33 Pages
	Tentative Tender Drawing	.....	01 Page
Part – II	Price Bid	.....	08 Pages

**Note:**

1. Part – I: To be submitted in a separate sealed cover.
2. Part – II: To be submitted in a separate sealed cover.
3. Earnest Money Deposit of Rupees 1.86 Lakhs shall be submitted as per point No. 4 of page No. 1 of this tender document.
4. Tenders will be liable for rejection if the above mentioned EMD is not submitted along with the tender.
5. Part-I, Part-II, Tender EMD sealed covers should be put in outer envelope and super scribing the Name of work and Name & Address of the Tenderer.
6. **Firms banned by BHEL are not eligible to participate in the tender. The tender envelope submitted by such a firms will not be opened for evaluation and no communication in this regard will be entertained.**

NIT Issued By

*Mowleeswaran Natesan*

Mowleeswaran Natesan,  
Dy. Manager-Civil, BHEL-EDN

CONTACTOR (SIGN & SEAL)



BHARAT HEAVY ELECTRICALS LTD, ELECTRONICS DIVISION, BANGALORE-26

TENDER NUMBER RFQ: EDN: PVSS: WBDCL: 5 MW: CR/02; Dt: 30.04.2019

PART-I TECHNICAL-CUM-COMMERCIAL BID

(To be furnished by the Bidders)

01. NAME OF THE WORK : **Construction of RCC Control Room buildings and other associated works for 5 MW floating Solar PV power plant for WBDCL, SAGARDIGHI at West Bengal.**  
(All listed works shall be Undertaken and executed)
02. APPROXIMATE ESTT.COST RS. : Rs.93.00 Lakhs (APPROX.) Plus applicable GST.
03. COMPLETION PERIOD : 4 Months.  
(From the date of placement of Order/handing over of site.)
04. NAME OF THE CONTRACTOR :
05. ADDRESS
- (A) OFFICE :
- E-mail :
- TEL. PH. NO. :
- (B) RESIDENCE :
- TEL.PH NO :
06. PAN NO :
07. GST NO :
08. STAFF STRENGTH :
09. PLANT/EQUIPMENTS : List enclosed/not enclosed
10. a) SCOPE OF WORK : UNDERSTOOD/ NOT UNDERSTOOD  
(As per schedule of items)
- b) Accept to execute in total : YES/ NO
- c) Bar chart to be submitted : YES/ NO  
Individually for each work

NIT Issued By

*Mowleeswaran Natesan*

Mowleeswaran Natesan,  
Dy. Manager-Civil, BHEL-EDN

CONTACTOR (SIGN & SEAL)



- e) In order to complete the project in the specified months schedule, vendor to deploy separate Four gangs/teams (or) more as per site requirement for each individual activities along with tools and machineries, Undertaking should be submitted along with offer : YES/ NO
11. a) EMD PARTICULARS (DEMAND DRAFT/ SBI COLLECT REF NO. / BG DETAIL) :
- b) Electronic Funds Transfer (EFT) form enclosed : Please fill up the form in ANNEXURE-II
12. Penalty as per BHEL General conditions of contract 2019 clause No. 2.7.9 : Accepted / Not accepted
13. Constitution of Firm : Individual / Sole Proprietorship Concern / Partnership Firm / Public Ltd. Company/ Private Ltd. Company.
14. BHEL reserves right to conduct reverse auction : Accepted / Not accepted
15. Accept to pay statutory payments like ESI, PF, BOCW, etc., as per terms and conditions of BHEL and Govt. guideline's : Accepted / Not accepted
16. BHEL Payment terms acceptance (Cl. no. 21, 22.1 & 22.2 of "Special Conditions of Contract") : Accepted / Not accepted
17. The bidder should encourage to use local labor that has the necessary skills as per the requirement of work. : Accepted / Not accepted

**Note:**

- 1. Bidders are advised to quote their best prices (% above/below the total estimate +/- (or) at par) as no further price bids will be accepted in case BHEL decides to open price bids instead of reverse auction.**
- 2. Reverse auction seal bid opening price should not be more than the manual quoted (hand written) price bid**

NIT Issued By

*M. Natesan*

Mowleeswaran Natesan,  
Dy. Manager-Civil, BHEL-EDN

CONTACTOR (SIGN & SEAL)



## PRE QUALIFICATION CRITERIA

1. Experience of having successfully completed RCC building works (such as Industrial, commercial and Residential) during last 7 years from the date of tender notice..

a) Three similar completed RCC building works each costing not less than an amount equal to 40% of NIT displayed value mentioned against each work in the tender notice (i.e., 40% of Rs.93 Lakhs = Rs.37 Lakhs).

OR

b) Two similar completed RCC building works each costing not less than an amount equal to 50% estimated value mentioned against each work in the tender notice (i.e., 50% of Rs.93 Lakhs = Rs.47 Lakhs).

OR

c) One similar completed RCC building works each costing not less than an amount equal to 80% estimated value mentioned against each work in the tender notice (i.e., 80% of Rs.93 Lakhs = Rs.74 Lakhs).

2. Average annual financial turn over during the last 3 years, ending 31st March of the previous financial year, should be 30% of the NIT displayed value (i.e., 30% of Rs.93 Lakhs = Rs.28 Lakhs).

**Note: Offers of the Tenderers not meeting the above requirements are liable to be rejected.**

### Documents required to be submitted

1. Registration Certificate with ESI and PF Authority/Declaration.
2. Income Tax Returns for last Three years
3. Balance Sheet and Profit & Loss Account for the last 03 years by auditor.
4. Availability of Technical personnel in letter head.
5. Registration with BHEL/CPWD/other Govt. organization/PSU if any.
6. Declaration for full filling the BOCW requirements in bidder's letter head.
7. List of equipment to be mobilized at site in bidder's letter head.
8. GST Registration details or Declaration in bidder's letter head.
9. Declaration by bidder's for not blacklisted and/or not banned by any PSU's (or) Government institutions/organizations (or) semi-Government institutions/organizations in bidder's letter head.

**All the supporting documents to be signed and sealed by the bidder (BHEL have the rights to verify the original documents if required)**

NIT Issued By

*M. Natesan*

Mowleeswaran Natesan,  
Dy. Manager-Civil, BHEL-EDN

CONTACTOR (SIGN & SEAL)



**INFORMATION TO THE TENDERER:**

- (i) Successful Bidder should establish their Site office at Construction site, including common facilities such as toilet, water, electricity etc. in consultation with BHEL. Contractor has to arrange water and power as required for completing the job in the stipulated time frame at their own cost.
  - (ii) The bidders should furnish "Site Inspection Certificate" in Annexure-III enclosed herewith.
  - (iii) Bidders should study the prevailing Market trend of Construction materials/laborers/other relevant requirement before quote and submit the competitive price.
  - (iv) The bidder should encourage to use local labor that has the necessary skills as per the requirement of work.
  - (v) Before engaging the labour in to work, Contractor should get the NOC from labours' native police station as well as NOC from local police station (If applicable).
  - (vi) The bidders should carry out preliminary survey at proposed construction site before submission of offer to ensure that the rate quoted for the relevant schedule of items are correct.
  - (vii) Contractor to note BHEL reserves the right to get any part of the work done through other agency or deploy BHEL's own/hired/otherwise arranged resources, at the risk and cost of the contractor after due notice of a period of two weeks by BHEL, in the event of:-
    - a) Contractors continued poor progress
    - b) Withdrawal from or abandonment of the work before completion of the work.
    - c) Contractor's inability to progress the work for completion as stipulated in the contract
    - d) Poor quality of work
    - e) Corrupt act of Contractor
    - f) Insolvency of the contractor
    - g) Persistent disregard to the instructions of BHEL
    - h) Assignment, transfer, sub-letting of contract without BHEL's written permission
    - i) Non fulfillment of any contractual obligations
    - j) In the opinion of BHEL, the contractor is overloaded and is not in a position to execute job as per required schedule.
  - (viii) The liquidated damages/penalties arising out of Risk and Cost as explained under Sl.no (vii). BHEL shall recover the amount from any money due from Contractor, or from any money due to the contractor including security deposit, or by forfeiting any T & P or material of the contractor under this contract or any other contract of BHEL or by any other means or any combination thereof.
- (vii) **Documents to be submitted on award of work (as applicable):**
- a) Security deposit in the form of Cash/DD/ NSC's / Kisan Vikas Patra / FDR / Bank Guarantee in favour of BHEL
  - (b) Electronic Fund Transfer Form duly signed & sealed by banker along with cancelled cheque copy

NIT Issued By

*M. Natesan*

Mowleeswaran Natesan,  
Dy. Manager-Civil, BHEL-EDN

CONTACTOR (SIGN & SEAL)



- (c) Labour license of the workmen engaged valid for contract period (If applicable)
- (d) Workmen Compensation Insurance Policy for the workmen engaged valid for contract period
- (e) Deduction of statutory taxes (as applicable) at source would be enforced from the running bills at the rates prescribed unless exemption certificate is produced from the concerned authorities.

The following documents are to be submitted along with the Running Account Bills for process of payment

- a) Tax Invoice with details of GST number of BHEL and contractor.
- b) Measurement books duly filled and signed by officials of BHEL and contractor
- c) Provident PF Remittance challan for the bill duration.
- d) ESI Remittance challan for the bill duration.
- e) Invoice submitted along with running bills to indicate the GST amount charged and bear GST NUMBER etc. as per prevailing taxes.

Bill submitted subsequently to be accompanied with a declaration that GST liability on the earlier bill has been discharged.

- i) by paying money to the Government (along with Tax paid Challan Copy)
- ii) by utilization of Input GST Credit
- f) BOCW Registration and payment proof.
- g) Field quality assurance documents (as applicable) as per instruction of Engineer In-charge.

#### **Mobilization at site:**

- 1) Requisite Material (all construction materials like cement, sand, coarse aggregate, reinforcement steel, etc.), men (mason, carpenter, bar binder, etc.) and machinery (Concrete mixer machine/RMC with printing facility, Power chain saw, JCB/excavator/dozer, Total station & other equipment for RCC building construction, etc.) should be arranged in order to complete the project within stipulated time period.
- 2) The contractor shall carry the work as per the approved Field Quality Plan issued by
- 3) Calibration of equipment's should be done by NABL accredited laboratories.
- 4) Contractor shall submit the design mix report (from NABL/Govt. approved labs) and shall carry the work as per the approved design mix report, approved by BHEL/ WBPDC.

NIT Issued By

*M. Natesan*

Mowleeswaran Natesan,  
Dy. Manager-Civil, BHEL-EDN

CONTACTOR (SIGN & SEAL)



**Bharat Heavy Electricals Limited**  
**ELECTRONICS DIVISION**  
MYSORE ROAD- BANGALORE-26  
**INSTRUCTIONS TO TENDERER**

1. Sealed Tender for the above noted work is hereby invited from Contractors experienced in similar civil works like RCC building works (such as Industrial, commercial and Residential).
2. Scope of work for: **Construction of RCC Control Room buildings and other associated works for 5 MW floating Solar PV power plant for WBPDC, SAGARDIGHI at West Bengal** as per Tender/approved construction drawing, works as per instruction of Engineer in charge, terms and condition of contract. However Depending on site conditions minor modification in works may be necessary.
3. Project Scope, detail and Location:

Site Detail	Project detail	Location
Project Site	5MWp (AC) SPV Power plant floating Solar PV power plant for WBPDC	Sagardighi, Dist.: Murshidabad West Bengal state

4. **Tenders should be addressed to: Sh. Sreenath M AGM (SC&PV- PCG, M), NEB 5<sup>th</sup> Floor, Electronics Division, Bharat Heavy Electricals Limited, Mysore road, Bangalore – 560 026. In three separate sealed cover for “Technical cum Commercial Bid”, Price Bid and DD for Tender document Cost (if applicable) & EMD duly super scribed and put in an outer envelope, super scribing the Name of work, Tender no. and Name and address of the Tenderer.**
5. The local address of the Contractors, the name of the person to whom all the Correspondence are to be addressed should be indicated, with telephone number (both office and residence).
6. All entries in tender documents should be in one ink (preferably blue ink). Erasing and overwriting is not permitted. All corrections should be duly signed by tenderer concerned.
7. Tenderers shall fill in all the required particular in the blank space provided for this purpose in the tender documents and also sign in each and every page of the tender document including the drawings attached there to before submitting tender.
8. Unit rate/percentage above or below estimate should be quoted in figures as well as in words in Indian Currency only i.e. Rupees and Paisa with reference to each item and for the items shown in the attached schedule. These rates shall be for the finished work at site. The rate shall include all taxes and

NIT Issued By

*M. Natesan*

Mowleeswaran Natesan,  
Dy. Manager-Civil, BHEL-EDN

CONTACTOR (SIGN & SEAL)



duties payable on account of Octroi, Sales Tax, tax on work contract etc., and also expenses towards PF and ESI contributions (see clauses 8, 40 and Enclosure 'C') but excluding

9. In case the rate quoted in figures differs from those quoted in words, the lower of the rates quoted will be taken as the tendered rate and shall be binding on the tenderer.
10. The rate to be quoted by the tenderer shall be firm and shall cover and include all statutory levies such as "Octroi, sales tax, excise duty etc., arising from Act passed by Parliament or State Legislature and rules framed there under. The rates shall further be deemed to include statutory levies arising from such Acts, Central or State, which may come into force, subsequent to submission of tenders.
11. (a) The rate quoted in the tender shall remain valid for a period of 'THREE MONTHS' from the date of opening tender.  
(b) Tenderer shall not increase quoted rates, once the tenderer has submitted offers/quotation/price and during execution of contract in case tender is accepted.  
(c) Successful bidder should execute the work strictly in accordance with Tender schedule quoted rates as accepted by BHEL.  
(d) **PRICE VARIATION clause not applicable.**
12. The rates quoted should be inclusive of all taxes arising on the transaction. If BHEL is required to discharge the liability of any taxes on the transaction like TDS(IT), TDS(WCT), TDS(GST) (as applicable) under reverse charge mechanism or any other similar taxes, which is or becomes payable by BHEL, the same shall be deducted from the bills of the contractor. **The rate/Percentage quoted by bidder shall be including all taxes but excluding GST which shall be shown separately in price bid.**
13. Quantities shown in the schedule are only approximate and are liable to variation without entitling the Contractors to any compensation.
14. Before tendering, the tenderer are advised to inspect the site of work and its environments and be well acquainted with the actual working and other prevailing conditions, position of material and labour. They should be well versed with BHEL General Conditions of Contract instruction to the tenderers, drawing and specification and all other documents which form part of the agreement to be entered into subsequent to award of work. The tenderer should be specially note that it is tenderers responsibility to provide any items which is not specifically mentioned in the specifications and drawing, but which is necessary to complete the work.
15. Details and quantities of each item of work shown in the bill of quantities attached here to only approximate. They are given as a guide for the purpose of tendering only and are liable for variation

NIT Issued By

*M. Natesan*

Mowleeswaran Natesan,  
Dy. Manager-Civil, BHEL-EDN

CONTACTOR (SIGN & SEAL)



and alteration at the discretion of the competent authority. The work under each item as executed shall be measured and price at the corresponding rates to be quoted by the Contractor in the bill of quantities attached hereto.

16. Should a tenderer find discrepancies or omission in the drawing attached to the tender documents or should be in doubt as to their meaning he should at once address to the authority inviting the tender for clarifications. Every endeavor is made to avoid any error which can materially affect the basis of the tender but successful tenderer shall take upon himself to provide for the risk of any error which may be subsequently discovered and shall make no subsequent claim on account thereof.
17. In the event of the tender being submitted by a firm the tender must be signed separately and legibly by each partner or member of the firm or in their absence, by the person holding the power of Attorney on behalf of firm concerned. In the latter case, a copy of the power of Attorney duly attested by a Gazette Officer must accompany the tender.
18. If in any case, the date of Tender Opening falls on holiday, the Tender will be opened on the next working day.
19. Every tender must be accompanied by Earnest Money Deposit. This earnest money will be refunded to the unsuccessful tenderer after finalization of the award of work. In the case of successful tenderer, the earnest money will be retained as a part of Security Deposit for satisfactory completion of the work in accordance with Clause-16 of BHEL General Conditions of the Contract. Tenders without Earnest Money Deposit receipt are liable to reject. No interest will be paid on the earnest money deposit.
20. **The Earnest money deposit may be furnished**
  - a) **Demand Draft in favour of BHEL EDN, Bangalore – 560026.**
  - b) **The Earnest money deposit may be furnished through online from SBI Collect.**

NIT Issued By

Mowleeswaran Natesan,  
Dy. Manager-Civil, BHEL-EDN

CONTACTOR (SIGN & SEAL)



## Guidelines for payment of EMD Fee

Step-1: Please enter the following link in your internet address browser or click on the following link.  
<https://www.onlinesbi.com/sbicollect/icollecthome.htm>

Please click on "proceed" after Clicking "Check Box" to proceed for payment

Step-2 : Now the SBI's SB-Collect site gets opened. Please select State of Corporation as "Karnataka" and type of Corporation as "Industry" and then click on "Go" appearing on the screen.

Step-3 : Now select "Bharat Heavy Electricals" from the dropdown table appearing against "Industry Name" and click Submit

Step-4: Now select "Others" from the dropdown table appearing against "Category" and click Submit

Step-5: The below screen (similar) will appear. Please select sub category "EMD" and fill up other details and transfer money.

State Bank Collect / State Bank Collect

State Bank Collect

 BHARAT HEAVY ELECTRICALS LTD  
BHEL HOUSE, SIRI FORT, NEW DELHI-110003

Provide details of payment

Select Payment Category \*

SUB CATEGORY \*

NAME \*

VENDOR CODE

AMOUNT \*

Remarks

Please enter your Name, Date of Birth (For Personal Banking) / Incorporation (For Corporate Banking) & Mobile Number. This is required to reprint your e-receipt / remittance(PAP) form, if the need arises.

Name \*

Date of Birth / Incorporation\*  

Mobile Number \*

Enter the text as shown in the image \*

21. For reimbursement of Earnest Money Deposit, the tenderer should fill the enclosed EFT form, obtain the Banker's signature and also enclose a photocopy of cancelled cheque leaf.
22. EMD may be submitted in Bank guarantee as per Sl. No. 4 (b), page No. 1, in BHEL format in Non-judicial stamp paper amounting Rs.200 (or) applicable rate at bidder's state, whichever is higher. **Bank guarantee from any Co-operative banks are not acceptable in any circumstances. (not applicable)**
23. Unless the bidder whose tender is accepted signs contract agreement within fifteen days (15 days) of the date of the order directing to do so, the amount of Earnest Money already deposited by bidder will be forfeited and acceptance of the tender withdrawn.

NIT Issued By



Mowleeswaran Natesan,  
Dy. Manager-Civil, BHEL-EDN

CONTACTOR (SIGN & SEAL)



24. If after opening of tenders a tenderer revokes the tender or increase of earlier quoted rates or after acceptance of his tender does not commence the work in accordance with the instruction of Engineer-in-charge, the Earnest Money Deposited by bidder will be forfeited and acceptance of bidder's tender withdrawn.  
If only a part of work included in the tender had been awarded to the tenderer, the amount of Earnest Money to be retained will be based on value of the contract so awarded.
25. The BHARAT HEAVY ELECTRICALS LIMITED reserve the right to reject any or all the tenders received or accept any tender or part thereof without assigning reason thereof. In the case of acceptance of a part of tender, the time for completion may also be reduced to the extent considered necessary by the accepting authority.
26. Conditional and Unsigned tenders, tenders which are incomplete or otherwise considered defective, tenders which are not in accordance with the tender conditions laid down by the accepting officer and tenders not submitted in the prescribed forms are liable to be rejected.
27. Tenderer shall submit Solvency Certificate for the value specified from a Bank of standing regarding the tenderer's financial position (as applicable).
28. The tenderers should enclose relevant documents regarding constitution of firm i.e. Individual / Sole Proprietorship Concern / Partnership Firm / Public Limited Company / Private Limited.
29. The tenders should be enclosed with a list of contracts already held by the tenderer at the time of submitting the tender and giving the following particulars:  
a) Name of the work, value and address.  
b) The balance work remaining to be done on the same.
30. a) The filled in tender sealed cover shall be handed over/couriered/speed post to at office of **Sh. Sreenath M AGM (SC&PV- PCG, M), NEB 5<sup>th</sup> Floor, Electronics Division, Bharat Heavy Electricals Limited, Mysore road, Bangalore – 560 026)** before the time fixed for submission of tender.  
b) Tenders received after the due date & time of opening of tenders will be rejected.
31. The Contractors responsibility under this contract shall commence from date of receipt of the order or acceptance of tender.
32. Tenders submitted by speed post or courier service shall be posted with due consideration of any delay in postal delivery. Tenders received after the due date of opening tenders are liable to be rejected.

NIT Issued By

*M. Natesan*

Mowleeswaran Natesan,  
Dy. Manager-Civil, BHEL-EDN

CONTACTOR (SIGN & SEAL)



33. If proprietor or partner of a firm expires after the submission of tender or after the acceptance of tender, BHEL reserves the right to cancel the contract if the character of the firm undergoes a substantial change.
34. THE BHARAT HEAVY ELECTRICALS LIMITED will not be bound by any power of Attorney granted by the tenderer or changes in the composition of firm made subsequent to signing of the contract. They may however recognize such power of Attorney and changes after obtaining proper legal advice.
35. If the tenderer deliberately gives wrong information on tender regarding past unsatisfactory performance with BHEL sister units, BHEL reserves the right to reject such tender at any stage including contract execution period.
36. Words imparting the singular number shall also be deemed to include the plural number and vice-versa where the context so require.
37. The General and Special Conditions are complementary to each other and where they are in conflict, the special condition shall prevail.
38. The expenses for completing the stamping agreement shall be paid by the contractor.
39. Unless or otherwise stated above tendered work includes men, material, machine and commissioning of equipment as agreed to in the contract.
40. After completing of the job, the contractor has to furnish actual drawings of work done in consultation with Engineer-in-charge.
41. Any covering letter and comments of the tenderer should be submitted along with the offer.
42. Cement and steel for carrying out Civil Works will have to be procured by the Contractor. Materials shall be accompanied with Test certificates and connected dispatch documents for proof of source from approved manufacturer's works or stockyard. The Contractor shall provide all the materials needed for trial run, testing including chemicals, consumables etc. In quoting their rates, the Contractors are advised to take into account the cost of the above materials. All the construction materials should be approved by BHEL before commencement of work.
43. Contractor are required to follow Field Quality Plan (FQP) for Civil construction as approved by BHEL/customer in respect of Tests to be carried out and reports and documents to be furnished.
44. Should a tenderer or a contractor has a relative or in the case of firm or company, any of its shareholders relative is employed in Bharat Heavy Electricals Limited, the authority inviting tenders shall be informed of this fact at the time of submission of the tender, failing which tender may be disqualified or if such fact subsequently comes to light.

NIT Issued By

*M. Natesan*

Mowleeswaran Natesan,  
Dy. Manager-Civil, BHEL-EDN

CONTACTOR (SIGN & SEAL)



45. These 'INSTRUCTIONS TO TENDERER' & GENERAL CONDITIONS OF CONTRACT OF BHEL' shall be deemed to form an integral part of the Contract agreement for the work to be entered into. The Contractor has to scrutinize the same, and when submitting his tender, indicate his acceptance of both. In cases of variation between the two in any matter, the conditions in the 'THE INSTRUCTIONS TO TENDERER' shall prevail. (Extracts of important clauses of BHEL GCC are enclosed).
46. All operations to be carried out by the Contractor during the execution of the contract such as drilling, welding etc., shall be done with proper equipment to be brought by the tenderer. Contractor shall make his own power and water supply.
47. The Contractor shall comply with the provision of Employees Provident Fund's and miscellaneous Provisions Act 1952 and rules, regulations and other orders issued there under. He as an employer shall be liable to pay employer's contribution/deductions towards PF under the PF Act in respect of all labour employed by him for the execution of the contract in accordance with the provisions of the Employees' Provident Funds and Miscellaneous Provisions Act, 1952 as amended from time to time. For this purpose he shall indicate the code number obtained from the Regional Provident Fund Commissioner or he should obtain a code number if he has not and produce the Photostat copy of the challan receipt of monthly remittance of the contribution made by him to the Commissioner. He shall also furnish such returns such returns as are due, under the Act, to be sent to the appropriate authorities through the Principal Employer".
48. The Contractor should get himself registered with the E.S.I Authorities as an independent Employer, obtain a separate code number and remit the dues in respect of the Labour employed by him for the work and produce the challan/Receipts of remittance of the ESI contributions due under the E.S.I Act to the Company authorities. He shall also furnish such returns, as are due, under the Act, to be sent to the appropriate authorities' through the Principal Employer. The contractor can remit their ESI & PF through a sub-agent who processes the ESI & PF code and agrees to enter an MOU with the contractor.
45. If any action is brought in by P.F. Commissioner/ESI authorities on BHEL for the work done by the Contractor for his labourers regarding PF/ESI amount due, short remittances, non-remittances etc., the Contractor shall defend the case on behalf of BHEL and / or reimburse BHEL the expenses so incurred.
46. The Contractor shall apply and obtain license under Contract labour (R&A) Act 1970 and comply the relevant provisions of this Act in respect of the labour employed by him for executing this contract. The contractor shall furnish necessary returns to the authority through the Principal Employer.

NIT Issued By

*M. Natesan*

Mowleeswaran Natesan,  
Dy. Manager-Civil, BHEL-EDN

CONTACTOR (SIGN & SEAL)



47. Contractor shall insure all his labourers and material. Any claim by his Employees for damages shall be settled by the Contractor even if action is against BHEL or to reimburse the legal expenses incurred by BHEL.
48. Any action brought in by anybody on BHEL regarding patent, right etc., used by Contractor in execution of work shall be defended by the Contractor and / or reimburse BHEL the cost of the same.
49. Contractor shall produce necessary records, documents; explanation whenever he is called upon to do by any Government Agencies.
50. Contractor should obtain "Workmen Compensation Policy" for their Employees.
51. LEAD, LIFT, DEWATERING ETC.,
- Unless otherwise specified in the tender schedule, the rates for all items will be deemed to include all leads, lifts and descents involved in the work.
  - No separate payment will be made for dewatering (including seepage, surface drainage and monsoon water) desludging and allied operations at any stage of the work, and the cost of such operations will be deemed to be included in the contract rates.
  - No separate payment will be made for curing including pumping of curing water where ever necessary.
52. EXTRA ITEMS
- No extra items of work shall be carried out by the contractor other than those authorized to do so in writing by the Engineer-in-charge. For any such items of work executed as per instructions of Engineer-in-charge, the rates will be fixed on the basis indicated under clause 50 of BHEL GCC/as per terms and conditions of BHEL. The schedule of rates to be followed in this case will be CPWD schedule of rates.

NIT Issued By

Mowleeswaran Natesan,  
Dy. Manager-Civil, BHEL-EDN

CONTACTOR (SIGN & SEAL)



**BHARAT HEAVY ELECTRICALS LIMITED**

(ELECTRONICS DIVISION)

MYSORE ROAD- BANGALORE-26

GENERAL CONDITIONS OF CONTRACT/TECHNICAL SPECIFICATION

It is hereby agreed by me/us that the BHEL General Conditions of Contract including subsequent amendments/ additions/deletions to clauses if any, and conditions pertaining the settlement of disputes by Arbitration form an integral part of the tender documents and that the tender submitted by me/ us is subject to the aforesaid BHEL General Conditions of Contract/ Technical Specification for Civil works which has been read and accepted by me/us.

NIT Issued By

*M. Natesan*

Mowleeswaran Natesan,  
Dy. Manager-Civil, BHEL-EDN

CONTACTOR (SIGN & SEAL)

**CLAUSE 20 OF GENERAL CONDITIONS OF CONTRACT****LABOUR**

The Contractor shall employ labour in sufficient numbers either directly or through sub-contractors to maintain the required date of progress and of quality to ensure workmanship of the degree specified in the contract and to the satisfaction of the Engineer-in-charge. The contractor shall not employ in connection with the works any person who has not completed his eighteen years of age.

The contractor shall furnish to the Engineer-in-charge at the intervals specified by him. A distribution return of the number and description by trades of the work people employed on the works. The Contractor shall also submit on the 4th and 19th or every month to the Engineer-in-charge a true statement showing in respect of the second half of the preceding month and the first half of the current month (i) the accidents that occurred during the said fortnight showing the circumstances under which they happened and the extent of damage and injury caused by them and (ii) the number of female workers who have been allowed maternity benefits as provided in the maternity benefit Act, 1961 or Rules made there under and the amount paid to them.

The contractor shall pay to labour employed by him either directly or through sub-contractors wages not less than fair wages as defined in the contractors Labour Regulations.

The Contractor shall in respect of labour employed by him either directly or through sub- contractors comply with or cause to be complied by with sub-contractors, labour Regulations in regard to all matters provided therein.

The Contractors shall comply with the provisions of the payment of wages Act, 1936, Minimum Wages Act, 1948, Workmen's Compensation Act 1923, Industrial Disputes Act, 1947, Maternity Benefit Act 1961 or any modifications there of or any other law relating thereto and rules made there under from time to time.

The Contractors shall be liable to pay his contribution and the employees' contribution of the State Insurance Scheme in respect of all labour employed by him for the execution of the contract, in accordance with the provision of "The Employees', State Insurance Act, 1948", as amended from time to time. The Contractors shall apply to the ESI Authorities, get himself registered with them and obtain a code Number. He shall pay the remittances under his code Number only. The Contractor shall be liable

NIT Issued By

Mowleeswaran Natesan,  
Dy. Manager-Civil, BHEL-EDN

CONTACTOR (SIGN &amp; SEAL)



to pay his contribution and the Employees' contribution towards PF as per Provident Fund Rules and Regulations in respect of all labour employed by him for the execution of the contract.

The contractor shall apply to the PF Authorities, get himself registered and obtain a code number from them. He shall pay the remittances towards PF under his code Number only. The Engineer-in-charge shall on a report having been made by an Inspecting Officer as defined in the Contractors Labour Regulations have the power to deduct from the moneys due to the Contractor any sum required or estimated to be required for making good the loss suffered by a worker or workers by reason of non-fulfillment of the conditions of the contract for the benefit of workers, non - payment of wages or of deductions made from him or their wages which are not justified by the terms of the contract of non-observance of the said contractor's Labour Regulations.

The Contractors shall indemnify the BHEL against any payment to be made under and for observance of the regulation aforesaid without prejudice to his right to claim indemnity from these sub-contractors.

#### **MODEL RULES FOR LABOUR WELFARE**

The Contractor shall at his own expense comply with or cause to be complied with model Rules for Labour Welfare as appended to these conditions or rules framed by Government from time to time for the protection of health and for making sanitary arrangements for workers employed directly or indirectly on the works, In case the Contractors fails to make arrangements as aforesaid the Engineer-in-charge shall be entitled do so and recover the cost thereof from the contractor.

NIT Issued By

Mowleeswaran Natesan,  
Dy. Manager-Civil, BHEL-EDN

CONTACTOR (SIGN & SEAL)



**SAFETY CODE**  
**RESPONSIBILITIES OF THE CONTRACTOR IN RESPECT OF SAFETY OF MEN, EQUIPMENT, MATERIAL  
AND ENVIRONMENT**

1. Before commencing the work, contractor shall submit a "SAFETY PLAN" to the authorized BHEL Official. The 'SAFETY PLAN' shall indicate in detail the measure that would be taken by the contractor to ensure safety of men, equipment, material and environment during execution of the work. The plan shall take care to satisfy all requirements specified hereunder. The contractor shall submit Safety Plan along with his offer. During negotiations before placing of work order and during execution of the contract BHEL shall have right to review and suggest modification in the Safety Plan. Contractor shall abide by BHEL decision in this respect.
2. The contractor shall take all necessary safety precautions and arrange for appropriate appliances as per direction of BHEL or its authorized officials to prevent loss of human lives, injuries to personnel engaged, and damage to property and environment.
3. The contractor shall provide to its work force and ensure the use of the following personal protective equipment as found necessary and as directed by the authorized BHEL Officer:-Safety Helmets conforming to IS-2925: 1984.
  - (i) Safety Belts conforming to IS-3521: 1983.
  - (ii) Safety Shoes conforming to IS-1989: 1978.
  - (iii) Eye and Face protection devices conforming to IS-8520: 1977 and IS-8940: 1978.
  - (iv) Hand and body protection devices conforming to:
    - IS-2573: 1975
    - IS-6994: 1973
    - IS-8807: 1978
    - IS-8519: 1977

All tools, tackles, lifting appliances, material handling equipment scaffolds, cradles, safety nets, ladders, equipment's etc. used by the contractor shall be of safe design and construction. These shall be tested and certificate of fitness obtained before putting them to use and from time to time as instructed by authorized BHEL Official who shall have the right to ban the use of any item.

All electrical equipment's, connections and wiring for constructions power, its distribution and use shall conform to the requirement of the Indian Electricity Act and Rules. Only electricians licensed by the

NIT Issued By

Mowleeswaran Natesan,  
Dy. Manager-Civil, BHEL-EDN

CONTACTOR (SIGN &amp; SEAL)



appropriate statutory authority shall be employed by the contractor to carry out all types of electrical works.

All electrical appliances including portable electric tools used by the contractor shall have safe plugging system to source of power and be appropriately earthed. The contractor shall not use any hand lamp energized by electric power with supply voltage of more than 24 volts. For work in confined space lighting shall be arranged with power sources of not more than 24 volts.

The Contractor shall adopt all fire safety measures as laid down in the "Code for fire Safety at Construction Sites" issued by the Safety Department of the Construction Management (HQ) of BHEL and as per directions of the authorized BHEL Official. A copy of the above referred "Code of Fire Safety at the Construction Sites" shall be made available by BHEL to the contractor for reference, on demand by the contractor, during tendering stage itself.

Where it becomes necessary to provide and/or store petroleum products, explosives, chemicals and liquid or gaseous fuel or any other substance that may cause fire or explosion, the contractor shall be responsible for carrying out such provisions and/or storage in accordance with the rules and regulations laid down in the relevant government acts, such as Petroleum Act, Explosives Act, Petroleum and Carbides of Calcium Manual of the Chief Controller of Explosives, Govt. of India. etc., prior approval to the authorized BHEL Official at the site shall also be taken by the contractor in all such matters.

The contractor shall arrange at his cost (wherever not specified) appropriate illumination at all work spots for safe working when natural daylight may not be adequate for clear visibility.

The contractor shall be held responsible for any violation of statutory regulations local, state or central and BHEL instructions that may endanger safety of men, equipment, material and environment in his scope of work or another contractor or agencies. Cost of damages if any, to life and property arising out of such violation of statutory regulations and BHEL instructions shall be borne by the contractor.

In case of a fatal or disabling injury accident to any person at construction sites due to the lapses by the contractor, the victim and/or his/her dependents shall be compensated by the contractor as per statutory requirements. However, if considered necessary, BHEL shall have the right to impose appropriate financial penalty on the contractor and recover the same from payments due to the contractor for suitably compensating the victim and/or his/her dependents. Before imposing any such penalty, appropriate enquiry shall be held by BHEL giving opportunity to the contractor to present his case.

NIT Issued By

Mowleeswaran Natesan,  
Dy. Manager-Civil, BHEL-EDN

CONTACTOR (SIGN & SEAL)



In case of any damage to property by the contractor, BHEL shall have the right to recover cost of such damages from payments from payments due to the contractor after holding an appropriate enquiry.

In case of any delay in the completion of a job due to mishaps attributable to lapses buy the contractor; BHEL shall have to recover cost of such delay from payments due to the contractor, after notifying suitably and giving him opportunity to present his case.

If the contractor fails to improve the standards of safety in its operation to the satisfaction of BHEL after being given a reasonable opportunity to do so; and/or if the contractor fails to take appropriate safety precautions or to provide necessary safety devices and equipment or to carry out instructions regarding safety issued by the authorized BHEL Official, BHEL shall have the right to take corrective steps at the risk and cost of the contractor after giving a notice of not less than seven days indicating the steps that would be taken by BHEL.

The contractor shall submit report of all accidents, fires and property damage, dangerous occurrence to the authorized BHEL Official immediately after such occurrence, but in any case not later than twelve hours of the occurrence. Such reports shall be furnished in the manner prescribed by BHEL. In addition, the contractor to the authorized BHEL Official shall also submit periodic reports on safety from time to time as prescribed.

Before commencing the work, the contractor shall appoint/nominate a responsible officer to supervise implementation of all safety measures and liaison with his counterpart of BHEL.

If safety record of the contractor in execution of the awarded job is to the satisfaction of Safety Department of BHEL, issue of an appropriate certificate to recognize the safety performance of the contractor may be considered by BHEL after completion the job

NIT Issued By

Mowleeswaran Natesan,  
Dy. Manager-Civil, BHEL-EDN

CONTACTOR (SIGN & SEAL)



## SPECIAL CONDITONS OF CONTRACT

### 1. GENERAL

The special conditions of contract and other contract documents are complimentary to each other and shall be read in conjunction with each other. In case of any conflict of meanings between the special conditions of contract and the BHEL General Conditions of Contract the provisions of the special conditions of contract shall override the corresponding provisions of the BHEL General Conditions of Contract.

### 2. SCOPE OF WORK

The scope of work includes for the full, final and entire completion **Construction of RCC Control Room buildings and other associated works for 5 MW floating Solar PV power plant for WBPDC, SAGARDIGHI at West Bengal** as detailed in specifications and drawings, which forms part of this Contract. The scope of work also includes cleaning/removing all debris in line with bill of quantity as directed by Engineer In-charge. The scope of work under this contract shall cover supply of all materials, labour, tools, and plants etc., unless otherwise specified in the specifications, descriptions of items or in foregoing clauses.

### 3. SITE CONDITIONS

a) Before tendering the Contractor shall get themselves acquainted with site conditions such as the nature of soil likely to be encountered during the course of the work etc,. The rates quoted by the contractor shall be deemed to have been quoted after getting acquainted with the prevailing site conditions. Initial jungle clearance, stripping of top soil etc., shall also be included in the quoted rates. No claims on the pretext of ignorance of site conditions shall be entertained.

b) The site of work is as mentioned in the Tender document.

### 4. SITE FACILITES

#### A. LAND

The Employer will allot land as available free of cost to the contractor for his office stores. He must maintain the areas allotted to him in a neat and clean conditions as required by the Employer. The contractor shall provide adequate storage and office facilities with approval from the Engineer. The rate quoted by the contractor shall be deemed to include for these and no separate payment will be made towards these. On completion of work, the site shall be cleaned by the contractor of all materials, temporary debris, rubbish plants and equipment's, belonging to the contractor at no extra cost. The site and surroundings shall be handed over in a neat and clean condition. In case of any failure by the contractor, the employer will get inside cleared at risk and cost of the Contractor.

NIT Issued By

Mowleeswaran Natesan,  
Dy. Manager-Civil, BHEL-EDN

CONTACTOR (SIGN & SEAL)



## **B. POWER AND WATER SUPPLY**

Facilities for drawing Power and water required at site for execution of the works shall be arranged by the contractor at his expense and risk. The necessary source for power & water supply has to be organized by vendor. Necessary distribution box, extension board points duly earthed, and with armoured safe power cables to be laid across the field provided point shall be in the scope of the tenderer. Further, laying of water intake and distribution pipes across the Site to various points of work from Electricity source provided water source point shall be in the scope of the tenderer. If required D.G generation sets shall be provided for Power arrangement by the contractor at his own cost. The tenderer shall make provision for temporary storage of water at suitable locations with pump if required to reach the water supply to work areas. The contractor will have to make his own arrangements for the same, without claiming any extra charge for the power and water drawal and distribution equipment.

## **5. MACHINERY**

The Contractor shall at his own expense, supply all tools, plant and equipment (hereinafter referred to as T & P) required for execution of contract, as specified in the tender documents. whole of the works shall be executed in perfect conformity with the specifications and drawings. If contractor perform any works in a manner contrary to the specifications and drawings and without reference to the Engineer-in-charge, he shall bear all the costs arising or ensuring there from.

- a) All technical documents regarding the construction of works are given in the metric system and work should be carried out according to metric system.
- b) The work shall be carried out as per detailed drawings supplied by the employer. The working drawings shall be emailed progressively to the contractor free of cost. The contractor shall keep one set of drawings (duly protected from dust and wear and tear) at his own expenses always available at site for reference of Engineer-in-charge and other representatives.
- c) The works shall be carried out as per detailed specifications enclosed with the tender. For items for which there is no mention in the drawings, detailed specification relevant IS specification (latest edition) shall be followed.
- d) The contractor shall submit to the Employer for their approval complete drawings, of all temporary works and staging which he may require for carrying out the works shown in the drawings.

NIT Issued By

*M. Natesan*

Mowleeswaran Natesan,  
Dy. Manager-Civil, BHEL-EDN

CONTACTOR (SIGN & SEAL)



He shall at the same time if so required by the Employer submit his calculations relating to strength and anticipated deflection in respect of any aforesaid temporary works. He shall also submit for the approval of Employer drawings showing the methods he proposes to adopt for the erection of the various parts of the temporary works. Any modification to the drawings that may be required by the Employer shall be made by the contractor at his own cost. However, notwithstanding the approval of modification required for temporary works, the contractor shall be fully responsible for their efficiency, security and maintenance and for all obligations and risks in regard to such works, specified or implied in this contract and he shall reinstate the same at his own cost, should any mishap or accident occur causing damage or injury there from, subject however, to such clauses of the General conditions as may be applicable in such cases.

#### **6. BENCH MARKS AND REFERENCE POINTS**

The contractor shall construct and maintain proper benchmarks and reference points of the inter section of all main walls, no separate payment shall be made for this and rates quoted deemed to include this cost. Surveying where ever required is in contractor scope.

#### **7. SAFETY PRECAUTIONS**

The contractor shall at times observe the safety code and make necessary action as required in the tender. In default thereof, the employer may get this done departmentally or through other agencies and recover the cost from the contractor.

The Contractors shall also abide by all the security regulations promulgated from time to time by employer.

#### **8. RATES**

The rates to be quoted are intended to provide for works duly and properly completed in accordance with the general and special conditions of contract and specifications and drawings together with such alteration and/or conditions as may be required / ordered without prejudice to the generality thereof shall include for detail of construction which are obviously and fairly intended and which may not have been specifically referred in these documents and working drawings and but are essential for execution and satisfactory completion of work including those of minor nature and shall be deemed to include and cover internal the followings.

- a) Arrangements for obtaining the clearance wherever required from statutory bodies, regarding license for construction, permanent electricity, water supply, and sanitary connections including

NIT Issued By

*M. Natesan*

Mowleeswaran Natesan,  
Dy. Manager-Civil, BHEL-EDN

CONTACTOR (SIGN & SEAL)



payment of necessary fees, inspection charges and obtaining financial certificates for using these services.

The various items rates quoted in the schedule as applicable shall be deemed to include the above services and no separate payments shall be made towards these.

- b) The cost of all superintendence and labour materials, tools, plants, equipment's, mobilizing and demobilizing equipment fuel lubricants, fixture, transport charges, temporary and permanent works and quarrying charges, testing, screening, washing, handling of materials, stacking and removal charges, of any rejected materials and water and power arrangements and satisfactory maintenance of the same satisfactory completion of the work intended.
- c) All fees, duties, royalties, rent and compensation to owner for surface damage or taxes and impositions payable to local authorities, in respect of land an structure, for all materials supplied for the work or any other duties/expenses for which the contractor may become liable or may be put to under any provision of the law for the purpose of in connection with the execution of the contract including levies payable on the transactions.
- d) Settings out of works profiles etc., and of construction repair and up-keep of all centre lines, bench marks and levels and page there of including provisions of masonry/concrete pillars showing the centre line of structure/gridlines and levels and maintenance and protection of the some including providing fencing etc., throughout the period of contract.
- e) Breaking, maintenance and removal of temporary works and buildings.
- f) Supply of complete, Moulds, cost of testing of materials etc.
- g) Working in all conditions including in/under water liquid, conditions etc., and shall also include bailing or pumping out water from the foundations, basements or any other sources of whatsoever de-sludging and allied operation at any stage of work including all suspension period and delays whatsoever. Cost of curing including pumping and cost of water whatever necessary.
- h) In the interest of completion of work within the stipulated time, certain works are to be carried out during the monsoon period also. No separate payment will be made to the contractor for such works and it will be deemed to be included in the contract rates.
- i) Diversion and draining works, protection works, temporary facilities, bridges, gangway.
- j) Work at all depth in foundation below the ground level and in superstructure up to all height above ground level including all lifts and distances involved at any other place of work and disposed/barrow areas.

NIT Issued By

*M. Natesan*

Mowleeswaran Natesan,  
Dy. Manager-Civil, BHEL-EDN

CONTACTOR (SIGN & SEAL)



- k) Unless otherwise specified in the specification schedule cost of all leads/lifts etc.
- l) Provision of centering, scaffolding, strutting props etc.,
- m) All materials and labour required for fencing in a protection against risk of accidents and for providing necessary/planking strutting with hand rails, gumboots, helmets, safety belts etc., during the progress of work.
- n) Prevention on trespassing by providing barrier arrangements for the safety of the public or employees during the provision of works.
- o) Works in all shapes include and curved all sizes as shown are as required.
- p) Cleaning the site after the completion of work all debris, left out construction materials machine equipment's, temporary offices, stores, works shop etc., including dressing the area neat and clean shape.
- q) Such other incidental charges or contingencies as may have been provided for in the specifications.

#### **9. LABOUR COLONIES**

Labour camp will not permitted within the project premises.

#### **10. ESCALATION**

The rates to be quoted by the tenderer shall be firm and shall cover and include all statutory levies, arising from, acts passed by parliament or by state legislature, the rates shall further be deemed to include statutory levies arising from such Acts, Central or State, which may come in to force subsequent to submission of tenders. The tenderer shall note that no claim for enhancement of rates, on the ground that existing statutory levies have been increased, or that new statutory levies have come in to effect after tender, or on any other ground, will be entertained on any account.

#### **11. QUANTITY**

The probable quantities of the several items of work are furnished in the schedule of quantities. It must be clearly understood that neither the probable quantities nor the value of individual items nor the aggregate value of the entire work shall be binding on the Employer/Engineer does not in any way assure the contractor or Guarantee that the said probable quantities are correct or that the work will correspond to these. The Employer/Engineer reserve the right to omit, vary or add to the item/work described in the schedule, of quantities and no claim for compensation will be entertaining on this account.

NIT Issued By

*M. Natesan*

Mowleeswaran Natesan,  
Dy. Manager-Civil, BHEL-EDN

CONTACTOR (SIGN & SEAL)



## **12. VARIATION/DEVIATION IN QUANTITIES**

The contractor shall not make any alteration in addition to or omission from the work as described in the tender document except in pursuance of the written instructions of the Engineer-in-charge. No such deviation from the work described in the tender documents shall be valid unless the same has been specifically confirmed and accepted by the accepting officer in writing and incorporated in the contract. The rates quoted are firm.

## **13. MATERIALS**

BHEL will not supply any materials unless otherwise specified.

## **14. SUPPLY OF CEMENT, STEEL, PAINT AND OTHER CONSTRUCTION MATERIALS, IS TO BE MADE BY CONTRACTOR**

**Makes / Source of supply of cement, steel, paint and other construction materials shall be as per approval of BHEL/WBPDCL.**

## **15. SUPPLY BY CONTRACTOR**

The work is for a completed job including labour and supply of all materials except those otherwise specified in the bid document.

The material and works shall be subject to inspection and test as per field quality plan (FQP) duly approved by BHEL/ WBPDCL..

All materials supplied by the contractor according to the contract conditions shall be subject to inspection and passing by the Engineer-in-charge or his representatives from time to time, the contractor providing all facilities for such instruction free of cost.

BHEL officers connected with the contract shall have the power at any time to inspect and examine any stores or materials intended to be used in or on the work, whether on the site or at any factory or workshop or other place where such stores or materials are being fabricated or manufactured or at any place the same are lying and the contractor shall give necessary facilities for such inspection and examination.

The Engineer-in-charge shall be entitled to have tests made of any stores or materials supplied by the contractor shall provide at his own expense all facilities which the Engineer-in-charge may require for this purpose. If at the discretion of the Engineer-in-charge an independent expert is employed to make any such tests his charges shall be borne by the contractor only if the tests disclosed that the said stores or materials are not in accordance with the provision of the contract.

Should the Engineer-in-charge/Civil Engineer consider at any time during the construction or reconstruction on prior to the expiry of the Maintenance Period that the stores or materials provided by the contractor are unsound or of quality inferior to that contracted for, or otherwise not in accordance with the contract (in respect where the decision of the Engineer-in-charge/Civil Engineer shall be final and conclusive) the contractor shall on demand, in writing from the Engineer-in-charge specifying the stores or materials complained of, notwithstanding that the same may have been inadvertently passed, certified that and paid forth with remove

NIT Issued By

Mowleeswaran Natesan,  
Dy. Manager-Civil, BHEL-EDN

CONTACTOR (SIGN & SEAL)



the stores or materials so specified and provide other and suitable stores or materials at his own expense, to the entire satisfaction of the Engineer-in-charge/Civil Engineer and in the event of his failing to do so within a period to be specified by the Engineer-in-charge/Civil Engineer, in his demand aforesaid, the Engineer-in-charge/Civil Engineer may replace within the other stores or materials complained of at the risk and expense in all respect of the contractor.

The liability of the contractor under this conditions, shall not extend beyond the maintenance period aforesaid except as regards stores or materials which the Engineer-in-charge/Civil Engineer shall have previously given notice to the contractor to replace (Maintenance period for any work under this organization will be six months from the date of actual completion of the particular work and handing over to BHEL).

#### **16. INTERRUPTION TO THE WORKS**

While quoting the rates/prices the Contractor should take in to account the fact that due to the design or other stipulations at site, or the necessity to follow a particular sequence of overall construction operation, or non-supply of particular drawings, or the connected work or other reasons, interruptions are likely to be encountered in a work of this nature and magnitude. No claims for such interruptions will be entertained on any account.

#### **17. EXTENSION OF TIME OR PENALTY/LIQUIDATED DAMAGES**

Extension of time or penalty/liiquidated damages as the case may be will be determined as stipulated in clause No. 2.7.9 of BHEL General Conditions of Contract 2019.

#### **18. COMPLETION OF WORK AND MEASUREMENT**

- a) All work shall be carried out according to authorized dimensions and measurement will be restricted to those authorized dimension even though the Contractor may for convenience of this work exceed the authorized dimensions.
- b) All work shall be measured in accordance with the applicable standard method of measurements prescribed by the Indian Standard Institution (1200 latest edition) unless otherwise specified.
- c) The Contractor shall admit for technical inspection, works which are likely to be embedded or covered by other works and have the necessary measurement books and certificates to this effect duly signed by the Engineer before the works are covered.
- d) On completion of the work, the Contractor must submit to the Engineer the following documents for passing of works.
  - i) A copy of the working drawing showing there on all addition and alterations in the process of execution.
  - ii) A certificate for embedded and covered up works as in sub-para (C) above
- e) The authorized Contractors representative and a representative of the Employer shall jointly sign a certificate of handing over any completed work and date of signature of that

NIT Issued By

*M. Natesan*

Mowleeswaran Natesan,  
Dy. Manager-Civil, BHEL-EDN

CONTACTOR (SIGN & SEAL)



certificate will be that the date from which the maintenance period of that unit will reckoned.

- f) Notwithstanding the above, insurance cover has to be taken by the contractor for the full value of work as also for the duration of the contract period. 50% of the Security Deposit shall be released only on the total completion of the building and handing over to BHEL to their satisfaction. Remaining 50% of Security Deposit shall be released subject to the stipulation in BHEL's GCC after 6 months from the date of completion of the building.

#### **19. MAINTENANCE OF WORK**

The contractor will be responsible for the maintenance of works during the period of construction until the various items are taken over, and for a further period of six months, from the date of taking over.

If the contractor fails to maintain the building satisfactorily, it will be got done by other agency and cost towards such maintenance together with departmental charges will be recovered from his bills/dues.

#### **20. SECURITY DEPOSIT**

Upon acceptance of the tender, the successful tenderer shall remit the security deposit with Bharat Heavy Electricals Ltd within the time as specified in the Letter of Intent.

The rate of Security Deposit will be 5% of work order value.

The contractor should submit the Security Deposit before the start of the work by

- i) Cash (as permissible under the income Tax Act).
- ii) Pay order, demand draft in favour of BHEL.
- iii) Local cheques of scheduled banks, subject to realization.
- iv) Securities available from Post Offices such as National Saving Certificates, Kisan Vikas Patras etc.,(Certificate should be held in the name of contractor furnishing the security and duly pledged in favour of BHEL and discharged on the back).
- v) Bank Guarantee from scheduled Banks/Public financial Institutions as defined in the companies Act subject to a maximum of 50% of the total security deposit value. The balance 50% has to be remitted either by cash or in the other form of security. The Bank Guarantee format should have the approval of BHEL.
- vi) Fixed Deposit Receipt issued by scheduled Banks/Public Financial Institutions as defined in the Companies Act. The FDR should be in the name of the contractor, A/C BHEL, duly discharged on the back.
- vii) Security Deposit can also be recovered at the rate of 10% from the running bills. However in such cases at least 50% of the Security Deposit should be collected before start of the work and balance 50% may be recovered from the running bills.
- viii) EMD of the successful tenderer shall be converted and adjusted against the Security Deposit. The Security Deposit shall not carry any interest.

NIT Issued By

*M. Natesan*

Mowleeswaran Natesan,  
Dy. Manager-Civil, BHEL-EDN

CONTACTOR (SIGN & SEAL)



**NOTE:** Accepting of Security Deposit against Sl. No. (iv) and (vi) above will be subject to hypothecation or endorsement on the documents in favour on BHEL. However, BHEL will not be liable or responsible in any manner for the collection of interest or renewal of the documents or in any other matter connected therewith.

For extra items of work and deviated quantities, security deposit will be recovered at 10% of the value of deviated amount. The security deposit will be released as stipulated under relevant clause of GCC 2019.

## **21. RUNNING ACCOUNT PAYMENTS**

During execution of work, monthly payments of all works in place will be made on the basic measurements recorded in measurement sheet/book in respect of items executed but no claim on the account will be entertained, if for any reason payments are not so made. PRICE VARIATION clause not applicable.

## **22.1 MOBILIZATION ADVANCE/ADVANCE PAYMENT - NOT APPLICABLE**

## **22.2 INTEREST & RECOVERY - NOT APPLICABLE**

## **23. Statutory Deduction towards Income Tax will be made as per rules.**

**24.** In respect of all labour directly or indirectly employed on the work by the Contractor, the Contractor shall comply with the provisions of the contract labour (Regulation and Abolition) Act 1970 or any amendment thereof and all legislations and rules of the State and or Central Government or other Authority, framed from time to time governing the protection of health, sanitary arrangements, wages, welfare and safety for labour employed on building and construction works. The rules and other statutory obligations with regard to fair wages, welfare and safety measures, maintenance of the register etc., will be deemed to be part of the contract.

**25.** The Contractor is required to take insurance for all workers employed on works towards payment for workmen compensation. The insurance has to be taken out within 15 days of the award of work and has to be produced at the time of signing agreement. Half (1/2%) shall be deducted for every bill if the contractor fails to produce a proof of having taken such an insurance to cover his workmen. However the contractor shall be fully responsible for all the consequences arising out of such default. This may also be read with relevant clauses of BHEL GCC 2019.

## **25. TIME OF COMPLETION**

The date of commencement of work shall be counted from the date of handing over the site to the contractor. It may be clearly understood that time is the essence of the contract and the entire work should be completed within the time imposed in the tender document letter of intent.

**26.** The Contractor has to pay the Works Contract Tax (Under relevant section of the State Government Act) of their own on Monthly basis.

**27.** The management of BHEL shall be at liberty to terminate the contract by issuing a month's notice to the contractor without assigning any reason what so ever. As regards unsatisfactory

NIT Issued By

Mowleeswaran Natesan,  
Dy. Manager-Civil, BHEL-EDN

CONTACTOR (SIGN & SEAL)



performance or noncompliance with any of the terms & conditions of the contract by the contractor. The management of BHEL shall have the right to terminate the contractor forthwith without notice & rearrange the balance work through other agencies at the risk & cost of the contractor & under such circumstances, the Earnest Money Deposit/Security Deposit paid by the contractor shall stand forfeited.

## **28. SPECIAL CONDITIONS OF TENDER**

- i) The successful bidder should open local office for Technical staff/Administrative group at Bangalore City for easy interactions/ monitoring of work at site./ Attend meetings at Bangalore city/site as and when instructed by BHEL.
- ii) Tenderers should not disclose any price bid details/discounts in the technical bids.
- iii) The successful bidder should construct site office / toilets for their workmen at site in consultation with Engineer-in-charge.

## **29. WORKMEN COMPENSATION POLICY**

The contractor is required to take Insurance for all the workers employed on the works towards payments for workmen compensation. The Insurance has to be taken out within 15 days of the award of work and has to be provided at the time of signing the agreement. Half percent (0.5%) of the amount shall be deducted from every bill if the contractor fails to produce a proof of having taken such an insurance to cover his workmen. However the contractor shall be fully responsible for the consequences arising out of such default.

NIT Issued By

*M. Natesan*

Mowleeswaran Natesan,  
Dy. Manager-Civil, BHEL-EDN

CONTACTOR (SIGN & SEAL)



## LIST OF INDIAN STANDARD

Following is the list of various Indian Standards,  
Relevant to the Civil Engg., work

---

### **1. EARTH WORK**

- i) IS 1200-1992, Method Part I Earthwork, Measurement of Building, and Civil Engineering works, and chapter No.2 of CPWD/specification 1977.

### **2. MORTAR (PLASTERING)**

- 1) IS 2394-1984: Code of practice for application of lime plasters finish.
- 2) IS 1661-1972: Code of practice for application of cement lime plasters finish.
- 3) IS 2402-1963: Code of practice for external rendered finishes.

### **3. CONCRETE WORK & RCC WORK**

- 1) IS 456-2000: Code of practice for plain and reinforced concrete.
- 2) IS 432(part 1) –1982( Third Revision): Mild steel and medium tensile steel bars
- 3) IS 1766-1998: Cold twisted steel bars for concrete reinforcement.

### **4. BRICK WORK**

- 1) IS 2212-1991: Code of practice for brick work.

### **5. STONE WORK**

- 1) IS 1597-1992 (Part – I & II): Code of practice for construction of stone masonry.

### **6. MARBLE WORK**

- 1) IS 1124-1974: Methods of test for water absorption of natural building works.

### **7. STEEL WORK**

- 1) IS 800-2007(Third Revision): Code of practice for use of structural steel in general building construction.
- 2) IS 1308-1984: Steels doors, windows and ventilators
- 3) IS 1081-1960: Code of practice for fixing glazing of metal (steel & aluminium doors, windows & ventilators)
- 4) IS 1161-1998: Steel tubes for structural purposes.
- 5) IS 4351-2003: Steel doorframes.
- 6) IS-6245-5245-1971: Metal rolling shutters and rolling grills.

NIT Issued By

*M. Natesan*

Mowleeswaran Natesan,  
Dy. Manager-Civil, BHEL-EDN

CONTACTOR (SIGN & SEAL)



## **8. FLOORING**

- 1) IS 2114-1984: Code of practice for laying in situ terrazzo floor finish.
- 2) IS 2571-1970: Code of practice for in situ cement concrete flooring.
- 3) IS 5318-1969: Code of practice of lying of flexible P.V.C. sheet & tiles flooring.

## **9. ROOFING**

- 1) IS 3007(pt-I)-1999: Code of practice of lying of corrugated cement sheets.

## **10. FINISHING**

- 1) IS 133-2004: Enamel, Interior (a) under coating (b) Finishing colour as required.
- 2) IS 348-1968: French Polish.
- 3) IS 427-2005: Distemper, dry colour as required.
- 4) IS 425-1969: Distemper, oil emulsion as required.
- 5) IS 5410-1992: Cement paint, Colour as required.
- 6) IS 5411 (pt.1)-1974: Plastic emulsion paint for interior use.
- 7) IS 6278-1971: Code of practice for white washing & color washing.

## **11. DEMOLISION AND DISMANTILING**

- 1) IS 1200 (pt. 18)-1974: Method of measurements of demolition and dismantling.

## **12. SAFETY CODE**

- 1) IS 5916-1970: Safety code for construction including use of hot bituminous materials.
- 2) IS 4130-1991: Safety code for demolition of building.
- 3) IS 3754-1966: Safety code for excavation works.
- 4) IS 3696(Pt-1)-1987: Safety code for Scaffolds.

### **A) DISTEMPERING ON NEW SURFACE. (OILBOUND)**

- |                      |       |                            |
|----------------------|-------|----------------------------|
| 1. COAT OF PRIMER    | ....  | 0.07 Litre/Sq.m (one coat) |
| 2. COAT OF DISTEMPER | ..... | 0.10 Kg/Sq.m (2 coats)     |

### **DISTEMPERING WITHOUT PRIMER**

- |             |       |                            |
|-------------|-------|----------------------------|
| FOR 1 COAT  | ..... | 0.10 Kg/Sq.m (For 1 coat)  |
| FOR 2 COATS | ..... | 0.15 Kg/Sq.m (For 2 coats) |

### **B) SYNTHETIC ENAMEL PAINT.**

- |                   |            |      |                               |
|-------------------|------------|------|-------------------------------|
| a) ON NEW SURFACE | ... PRIMER | .... | 0.09 Litre/Sq.m (For1 coat)   |
| ENAMEL PAINT      | (2 COATS)  | .... | 0.15 Litre/Sq.m (For 2 coats) |
| b) ON OLD SURFACE |            |      |                               |

NIT Issued By

*M. Natesan*

Mowleeswaran Natesan,  
Dy. Manager-Civil, BHEL-EDN

CONTACTOR (SIGN & SEAL)



2 COATS WITHOUT PRIMER	...	0.20 Litre/Sq.m
1 COAT	...	0.10 Litre/Sq.m
c) WATER PROOF CEMENT PAINT		
1 COAT	...	0.18 Kg/Sq.m
2 COAT	...	0.30 Kg/Sq.m
d) PLASTING EMULSION PAINT:		
2 COATS OF PLASTIC EMULSION	....	0.09 Litre/Sq.m
1 COAT OF PLASTIC EMULSION	....	0.073 Litre/Sq.m
<u>ON NEW SURFACE</u>		
1 COAT PLASTIC FIX PRIMER	...	0.081 Litre/Sq.m
2 COATS PLASTIC EMULSION	...	0.09 Litre/Sq.m

These standards are indicative, any additional IS standard/specification required to be followed shall be adhered to by the contractor.

NIT Issued By

*M. Natesan*

Mowleeswaran Natesan,  
Dy. Manager-Civil, BHEL-EDN

CONTACTOR (SIGN & SEAL)



## FORM OF TENDER

Having examined the invitation to bid, Instructions to Bidder, General conditions of contract, Special conditions, Specifications tender schedule, Contract drawings and other documents for the above work, we the undersigned, offer to construct, erect complete and maintain the whole of the said in conformity with the said bid documents on the terms and conditions and under the provisions set out or called for in the contract documents at the rates listed in the schedule of unit prices or elsewhere in the contract documents.

We undertake if our bid is accepted, to commence the works within 7 days from the date of issue of award and to complete and delivery the whole of the works comprised in the contract as per the time schedule agreed to the contract document.

We agree to abide by this bid for the period of three months from the date fixed for receiving the same and it shall remain binding upon us and may be accepted at any time before expiry of the period.

Until and unless a formal agreement is prepared and executed this bid, together with your award thereof shall constitute a binding contract between us.

NIT Issued By

Mowleeswaran Natesan,  
Dy. Manager-Civil, BHEL-EDN

CONTACTOR (SIGN & SEAL)



ENCLOSURE: C

**CLAUSE 58 OF GENERAL CONDITIONS OF CONTRACT**

**ARBITRATION:**

Except where otherwise provided for in the contract all questions and disputes relating to the meaning of the specifications, designs, drawings and instructions herein before mentioned and as to the quality of workmanship or materials used on the work or has been other as to any other questions, claim, right, matter or thing whatsoever in any way arising out of or relating to the contract, designs, drawings, specifications, estimates, instructions, orders or these conditions or otherwise concerning the works, of or the execution or failure to execute the same whether arising during the program progress of the work or after the completion or abandonment thereof shall be referred to the sole arbitration of the Executive Director/General Manager of BHEL and if the Managing Executive Director/General Manager Chief Engineer is unable or unwilling to act, to a as the sole arbitration of some other person appointed by the Executive Director / General Manager, willing to act as such Arbitrator. There will be no objection if the arbitrator so appointed is an employee of BHEL EDN or an employee of any other unit of BHEL and that he had to deal with the matters to which the contract relates and that in the course of its his duties as such he had expressed views on all or any of the matters in dispute or difference. The Arbitrator to whom the to matter is originally referred being transferred or by vacating his office or being unable to act for any reason, such Executive Director / General Manager as aforesaid at the time of such transfer, vacation of office or inability to act, shall appoint account another person to act as arbitrator in accordance with the terms of the contract, such person shall be entitled to proceed with the reference from the stage at which it was left by his predecessor. It is also a term of this contract that no person other than a person appointed by such Executive Director/General Manager or an employee appointed as arbitrator as aforesaid should act as arbitrator and the arbitrator shall give reasons for the award.

Subject as aforesaid the provision of the Arbitration Act, 1940 or any statutory modification or re-enactment thereof and the rules made there under and for the time being in force shall apply to the arbitration proceeding under this clause.

NIT Issued By

Mowleeswaran Natesan,  
Dy. Manager-Civil, BHEL-EDN

CONTACTOR (SIGN & SEAL)



It is a term of a contract that the party involving invoking arbitration shall specify the dispute or disputes to be referred to arbitration under this clause together with the amount or amounts claimed in respect of each such dispute.

The arbitrator(s) may from time to time with consent of the parties enlarge extend the time, for making the publishing the awards.

The work under the contract shall, if reasonably possible, continue during the arbitration proceeding and no payment due to or payable to the contractor shall be withheld on account of such proceedings.

The arbitrator shall be deemed to have entered on the reference on the date he issued notice to both the parties fixing the date of the hearing.

The arbitrator shall give a separate speaking award in respect of each dispute or difference referred to him.

The venue of arbitration shall be such place as may be fixed by the arbitrator in his sole discretion.

The award of the arbitrator shall be final, conclusive and binding on all parties to this contract.

NIT Issued By

Mowleeswaran Natesan,  
Dy. Manager-Civil, BHEL-EDN

CONTACTOR (SIGN & SEAL)

**Certificate by Chartered Accountant on letter head**

This is to Certify that M/S .....  
(hereinafter referred to as 'company') having its registered office at  
..... is registered under MSMED Act 2006, (Entrepreneur  
Memorandum No (Part-II) ..... dtd:.....  
Category: ..... (Micro/Small). (Copy enclosed).

Further verified from the Books of Accounts that the investment of the company as per the  
latest audited financial year ..... as per MSMED Act 2006 is as follows:

1. **For Manufacturing Enterprises:** Investment in plant and machinery (i.e. original cost  
excluding land and building and the items specified by the Ministry of Small Scale Industries vide its  
notification No.S.O.1722(E) dated October 5, 2006 :  
Rs.....Lacs
2. **For Service Enterprises:** Investment in equipment (original cost excluding land and building and  
furniture, fittings and other items not directly related to the service rendered or as may be notified under the MSMED  
Act, 2006:  
Rs.....Lacs

**(Strike off whichever is not applicable)**

The above investment of Rs.....Lacs is within permissible limit of  
Rs.....Lacs for .....Micro / Small (Strike off which is not applicable)  
Category under MSMED Act 2006.

Or

The company has been graduated from its original category (Micro/ Small) (Strike off which is not  
applicable) and the date of graduation of such enterprise from its original category is .....  
(dd/mm/yyyy) which is within the period of 3 years from the date of graduation of such  
enterprise from its original category as notified vide S.O. No. 3322(E) dated 01.11.2013 published  
in the gazette notification dated 04.11.2013 by Ministry of MSME.

Date:

(Signature)

Name -

Membership number -

Seal of Chartered Accountant

ANNEXURE II

NIT Issued By

*M. Natesan*

Mowleeswaran Natesan,  
Dy. Manager-Civil, BHEL-EDN

CONTACTOR (SIGN & SEAL)



**Electronic Funds Transfer (EFT) OR  
Paylink Direct Credit Form**

Please Fill up the form in **CAPITAL LETTERS** only.  
TYPE OF REQUEST(Tick one): \_\_\_\_\_ CREATE \_\_\_\_\_ CHANGE

BHEL Vendor / Supplier Code:	
Company Name :	
Permanent Account Number(PAN):	
Address	

City:		PINCODE		STATE	
-------	--	---------	--	-------	--

Contact Person(s)	
Telephone No:	
Fax No:	
e-mail id:	

1 Bank Name:	
2 Bank Address:	
3 Bank Telephone No:	
4 Bank Account No:	
5 Account Type: Savings/Cash Credit	
6 9 Digit Code Number of Bank and branch appearing on MICR cheque issued by Bank	
7 Bank swift Code(applicable for EFT only)	
8 Bank IFSC code(applicable for RTGS)	
9 Bank IFSC code(applicable for NEFT)	

- A I hereby certify that the particulars given above are true, correct and complete and that I, as a representative for the above named Company, hereby authorise BHEL, EDN, Bangalore to electronically deposit payments to the designated bank account.
- B If the transaction is delayed or not effected at all for reasons of incomplete or incorrect information, I would not hold BHEL / transferring Bank responsible.
- C This authority remains in full force until BHEL, EDN, Bangalore receives written notification requesting a change or cancellation.
- D I have read the contents of the covering letter and agree to discharge the responsibility expected of me as a participant under ECS / EFT.

Date:

Authorised Signatory:

Designation:

Telephone NO. with STD Code

Company Seal

**Bank Certificate**

We certify that \_\_\_\_\_ has an Account No \_\_\_\_\_ with us and we confirm that the bank details given above are correct as per our records.

Date:

(.....)

Place:

Signature

Please return completed form along with a blank cancelled cheque or photocopy thereof to:

Bharath Heavy Electricals Ltd,

Attn:

Electronics Division, Mysore Road,

BANGALORE - 560 026

In case of any Query, please call : 080-26998xxx / 2674xxxx or fax no. 080-2674xxxx

**ANNEXURE-III**

NIT Issued By

Mowleeswaran Natesan,  
Dy. Manager-Civil, BHEL-EDN

CONTACTOR (SIGN & SEAL)



Ref.  
Date:

**SITE INSPECTION CERTIFICATE**

This is to Certify that, I / We.....  
..... had inspected the proposed  
Construction site thoroughly and understood the scope of works to be carried out in  
line with construction drawings/designs/data/Bill of quantities/schedule of items /  
Specifications as brought out in the Tender as desired by BHEL.

Agreeable to all Terms & Conditions of Contract and assure to complete the work  
Within the stipulation time frame.

Signature of the contractor

Name:  
Seal

NIT Issued By

Mowleeswaran Natesan,  
Dy. Manager-Civil, BHEL-EDN

CONTACTOR (SIGN & SEAL)



## Additional Clauses for GST:

1. BHEL GST Number of Nodal Agency:

Nodal Unit Registered as Supplier of Goods/Services in GST: West Bengal  
GSTIN of Nodal Unit: Will be intimated later after award of work.

2. HSN (Harmonized System of Nomenclature) / SAC (Services Accounting Code) to be mandatorily mentioned in all quotations & invoices submitted.
3. Invoice submitted should be in the format as specified under GST Laws viz. all details as mentioned in Invoice Rules like GSTN registration number, invoice number, quantity, rate, value, taxes with nomenclature – CGST, SGST, IGST mentioned separately, HSN Code / SAC Code etc.
4. Payment of GST to vendors as applicable will be made only if it is matching with data uploaded by Vendors
5. Vendors to give undertaking that GST as mentioned in the Invoice has been paid/will be paid either through cash or admissible input credit and also file the returns
6. For invoices paid on Reverse charge basis – that it is “payable on reverse charge basis” to be mentioned on the invoice.
7. With respect to supplies, vendor should intimate BHEL immediately on dispatch for parallel billing on customer
8. Vendor should get GST registration, if not available, in the state of West Bengal immediately after placement of order.

NIT Issued By

Mowleeswaran Natesan,  
Dy. Manager-Civil, BHEL-EDN

CONTACTOR (SIGN & SEAL)

**UNPRICED PRICE BID**

**Construction of RCC Control Room buildings and other associated works for 5 MW floating Solar PV power plant for WBPDC, SAGARDIGHI at West Bengal".**

Sl. No.	Description of Work	Unit	Qty.	ITEM RATE (Excluding GST)	Amount
<b>(A) Civil Works</b>					
1	Earth work in excavation by mechanical means (Hydraulic excavator) / manual means over areas (exceeding 30cm in depth. 1.5 m in width as well as 10 sqm on plan) including disposal of excavated earth, lead upto 2km and lift upto 1.5m, disposed earth to be levelled and neatly dressed.all type of soil as per direction of Engineer in charge.	Cum	866.00	99.75	86385.58
2	Earth work in excavation by mechanical means (Hydraulic excavator) / manual means over areas (exceeding 30cm in depth. 1.5 m in width as well as 10 sqm on plan) including disposal of excavated earth, lead upto 2km and lift upto 1.5m, disposed earth to be levelled and neatly dressed.in soft rock complete as per direction of Engineer in charge.	Cum	162.00	175.07	28361.60
3	Earth work in excavation by mechanical means (Hydraulic excavator) / manual means over areas (exceeding 30cm in depth. 1.5 m in width as well as 10 sqm on plan) including disposal of excavated earth, lead upto 2km and lift upto 1.5m, disposed earth to be levelled and neatly dressed.in Hard rock complete as per direction of Engineer in charge.	Cum	54.00	490.88	26507.61
4	Filling available excavated earth/murram (excluding rock) in trenches, plinth, sides of foundations etc. in layers not exceeding 20cm in depth, consolidating each deposited layer by ramming and watering, lead up to 2 km and lift upto 1.5 m complete as per direction of Engineer in charge.	Cum	674.00	99.59	67126.36
5	Providing and laying in position cement concrete of specified grade excluding the cost of centering and shuttering - All work up to plinth level : 1:3:6 (1 Cement : 3 coarse sand (zone-III) : 6 graded stone aggregate 20 mm nominal size).	Cum	115.00	3902.18	448751.16
6	Providing and laying in position cement concrete of specified grade excluding the cost of centering and shuttering - All work up to plinth level :1:4:8 (1Cement : 4 coarse sand : 8 graded stone aggregate 20 mm nominal size) complete as per direction of Engineer in charge.	Cum	5.00	3546.69	17733.47
7	Providing and laying in position cement concrete of specified grade excluding the cost of centering and shuttering - All work upto floor V level : 1:2:4 (1 cement : 2 coarse sand : 4 graded stone aggregate 20/10mm mm nominal size) complete as per direction of Engineer in charge.	Cum	98.00	4763.74	466846.66
8	Providing and laying in position machine batched and machine mixed design mix M-25 grade cement concrete for reinforced cement concrete work, using cement content as per approved design mix, including pumping of concrete to site of laying but excluding the cost of centering, shuttering, and reinforcement, including admixtures in recommended proportions as per IS: 9103 to accelerate, retard setting of concrete, improve workability without impairing strength and durability as per direction of Engineer-in-charge. All works upto floor V level	Cum	319.00	5423.81	1730196.67
9	Providing and laying in position machine batched and machine mixed design mix M-30 grade cement concrete for reinforced cement concrete work, using cement content as per approved design mix, including pumping of concrete to site of laying but excluding the cost of centering, shuttering, and reinforcement, including admixtures in recommended proportions as per IS: 9103 to accelerate, retard setting of concrete, improve workability without impairing strength and durability as per direction of Engineer-in-charge. All works upto floor V level	Cum	5.00	5478.86	27394.29
10	Centering and shuttering including strutting, propping etc. and removal of form for :Foundations, footings, bases of columns etc. for mass complete as per direction of Engineer in charge.	sqm	261.00	153.61	40091.79
11	Centering and shuttering including strutting, propping etc. and removal of form for Columns, Pillars, Piers, Abutments, Posts and Struts complete as per direction of Engineer in charge. FOR ANY HEIGHT	sqm	268.00	370.54	99303.97
12	Centering and shuttering including strutting, propping etc. and removal of form for all heights : Lintels, beams, plinth beams, girders, bressumers and cantilevers FOR ANY HEIGHT	sqm	460.00	271.58	124925.33
13	Centering and shuttering including strutting, propping etc. and removal of form for Suspended floors, roofs, landings, balconies and access platform complete as per direction of Engineer in charge. FOR ANY HEIGHT	sqm	700.00	334.46	234123.12
14	Centering and shuttering including strutting, propping etc. and removal of form for all heights : Walls (any thickness) including attached pilasters, butteresses, plinth and string courses etc.	sqm	469.00	299.85	140630.21
15	Supplying and filling in plinth with sand/murram under floors, including watering,ramming, consolidating and dressing complete.	Cum	97.00	726.86	70505.23
16	Dry stone SOLING AVERAGE 22.5 cm thick including supply of stones, ramming with sand and preparing surface complete.	sqm	485.00	395.72	191925.56

**UNPRICED PRICE BID**

**Construction of RCC Control Room buildings and other associated works for 5 MW floating Solar PV power plant for WBPDC, SAGARDIGHI at West Bengal".**

Sl. No.	Description of Work	Unit	Qty.	ITEM RATE (Excluding GST)	Amount
17	Brick work with common burnt clay F.P.S. (non modular) bricks of class designation 7.5 up to floor V level in all shapes and sizes in : Cement mortar 1:6 (1 cement : 6 coarse sand)	cum	162.00	3953.41	640451.87
18	Half brick masonry with common burnt clay F.P.S. (non modular) bricks of class designation 7.5 up to floor V level. Cement mortar 1:4 (1 cement :4 coarse sand)	sqm	10.00	505.97	5059.69
19	15 mm cement plaster on the rough side of single or half brick wall of mix :1:6 (1 cement: 6 coarse sand). EXTERNAL PLASTER	sqm	741.00	154.12	114205.29
20	12 mm cement plaster of mix : 1:4 (1 cement: 4 coarse sand): INTERNAL PLASTER	sqm	791.00	143.23	113297.46
21	6 mm cement plaster of mix : 1:3 (1 cement : 3 fine sand) CEILING PLASTER	sqm	656.00	113.89	74711.58
22	Providing and laying vitrified floor tiles in different sizes (thickness should be 8mm) with water absorption less than 0.08% and conforming to IS: 15622, of approved make, in all colours and shades, laid on 30mm thick cement mortar 1:4 (1 cement : 4 coarse sand), jointing with grey cement slurry @ 3.3kg/sqm including grouting the joints with white cement and matching pigments etc., complete. Size of Tile 600x600 mm	Sqm	45.00	886.56	39895.42
23	Providing and laying anti skid Glazed Ceramic floor tiles of size 300x300 mm or more (thickness should be 8mm), of 1st quality conforming to IS : 15622, of approved make, in colours as approved by Engineer In-charge, laid on 30 mm thick cement mortar 1:4 (1 Cement: 4 Coarse sand), jointing with grey cement slurry @ 3.3kg/ sqm including grouting the joints with white cement and matching pigments etc., complete.	sqm	13.00	651.38	8467.95
24	Providing and fixing 1st quality ceramic glazed wall tiles conforming to IS: 15622 (thickness should be 6mm), of approved make, in all colours, shades in skirting, dados, over 12 mm thick bed of cement mortar 1:3 (1 cement : 3coarse sand) and jointing with grey cement slurry @ 3.3kg per sqm,including pointing in white cement mixed with pigment of matching shade complete.	Sqm	61.00	589.88	35982.78
25	Providing & fixing Acid and alkali resistant tile in flooring on a bed of 30 mm thick mortar 1:4 (1 acid proof cement : 4 coarse sand). Tile thickness should be 20mm.	Sqm	34.00	850.09	28903.17
26	Providing & fixing dado/skirting Acid and alkali resistant tile on 12 mm thick mortar 1:4 (1 acid proof cement : 4 coarse sand). Tile thickness should be 12mm.	Sqm	50.00	905.73	45286.56
27	Cement concrete flooring (IPS) 1:2:4 (1 cement : 2 coarse sand : 4 graded stone aggregate) finished with a floating coat of neat cement, including cement slurry, but excluding the cost of nosing of steps etc. complete. 40 mm thick with 10 mm nominal size stone aggregate IS 2571	sqm	184.00	287.18	52840.97
28	Cement plaster skirting up to 30 cm height, with cement mortar 1:3 (1 cement : 3 coarse sand), finished with a floating coat of neat cement. 18 mm thick	sqm	12.00	277.24	3326.88
29	Finishing with Epoxy paint/COATING 2mm thk heavy duty industrial grade (two or more coats) at all locations prepared and applied as per manufacturer's specifications including appropriate priming coat, preparation of surface, etc. complete. On concrete work	sqm	196.00	98.60	19326.38
30	Kota stone slabs 20 mm thick in risers of steps, skirting, dado and pillars laid on 12 mm (average) thick cement mortar 1:3 (1 cement: 3 coarse sand) and jointed with grey cement slurry mixed with pigment to match the shade of the slabs, including rubbing and polishing complete.	sqm	15.00	980.65	14709.82
31	Providing and laying Polished Granite stone flooring in required design and patterns, in linear as well as curvilinear portions of the building, all complete as per the architectural drawings, with 18 mm thick stone slab over 20 mm (average) thick base of cement mortar 1:4 (1 cement : 4 coarse sand), laid and jointed with cement slurry and pointing with white cement slurry admixed with pigment of matching shade, including rubbing, curing and polishing etc. all complete as specified and as directed by the Engineer-in-Charge. Polished Granite stone slab, colour as approved by Engineer In-charge.	sqm	5.00	2326.66	11633.29
32	Providing and fixing stone slab with table rubbed, edges rounded and polished, of size 75x50 cm deep and 1.8 cm thick, fixed in urinal partitions by cutting a chase of appropriate width with chase cutter and embedding the stone in the chase with epoxy grout or with cement concrete 1:2:4 (1 cement : 2 coarse sand : 4 graded stone aggregate 6 mm nominal size) as per direction of Engineer-in-charge and finished smooth. Granite Stone of approved shade	sqm	1.00	2242.90	2242.90

**UNPRICED PRICE BID**

**Construction of RCC Control Room buildings and other associated works for 5 MW floating Solar PV power plant for WBPDC, SAGARDIGHI at West Bengal".**

Sl. No.	Description of Work	Unit	Qty.	ITEM RATE (Excluding GST)	Amount
33	Providing and applying plaster of paris putty of 2 mm thickness of approved brand over plastered surface to prepare the surface even and smooth complete.	sqm	1447.00	94.01	136033.05
34	Finishing walls with Acrylic Smooth exterior weather proof/Heta reflective paint of required shade : New work (Two or more coat applied @ 1.67 ltr/10 sqm over and including priming coat of exterior weather proof primer applied @ 2.20 kg/10 sqm) EXTERNAL	sqm	741.00	76.07	56369.06
35	Wall painting with acrylic emulsion paint (for Internal walls) of approved brand and manufacture to give an even shade : Two or more coats on new work with primer	sqm	648.00	66.88	43341.09
36	White washing with lime to give an even shade : New work (three or more coats) CEILING	sqm	656.00	13.66	8962.27
37	Applying one coat of water thinnable cement primer of approved brand and manufacture on wall surface : Water thinnable cement primer CEILING	sqm	656.00	29.26	19197.45
38	Supplying and fixing rolling shutters of approved make, made of required size M.S. laths, interlocked together through their entire length and jointed together at the end by end locks, mounted on specially designed pipe shaft with brackets, side guides and arrangements for inside and outside locking with push and pull operation complete, including the cost of providing and fixing necessary 27.5 cm long wire springs manufactured from high tensile steel wire of adequate strength conforming to IS: 4454 - part 1 and M.S. top cover of required thickness for rolling shutters. 80x1.25 mm M.S. laths with 1.25 mm thick top cover	sqm	9.00	1834.35	16509.16
39	Providing and fixing pressed steel door frames conforming to IS: 4351, manufactured from commercial mild steel sheet of 1.60 mm thickness, including hinges, jamb, lock jamb, bead and if required angle threshold of mild steel angle of section 50x25 mm, or base ties of 1.60 mm, pressed mild steel welded or rigidly fixed together by mechanical means, including M.S. pressed butt hinges 2.5 mm thick with mortar guards, lock strike-plate and shock absorbers as specified and applying a coat of approved steel primer after pre-treatment of the surface as directed by Engineer-in-charge: Profile C: Fixing with adjustable lugs with split end tail to each jamb	meter	20.00	287.93	5758.63
40	Providing and fixing ISI marked flush door (MDF) shutters conforming to IS : 2202 (Part I) decorative type, core of block board construction with frame of 1st class hard wood and well matched teak 3 ply veneering with vertical grains or cross bands and face veneers on both faces of shutters. 35 mm thick including ISI marked Stainless Steel butt hinges with necessary screws	sqm	7.00	1971.25	13798.74
41	Providing and fixing thermal insulation of ceiling (under deck insulation) with mineral wool, density 45kg / m3, fixed to ceiling as per direction of Engineer In-charge.	sqm	41.00	336.68	13803.85
42	False ceiling: 600 x 600 x 12 mm thick gypsum board with one coat of primer and two or more coat of Acrylic emulsion paint. The suspension system shall consist of 6 mm diameter galvanised steel rods suspended from ceiling supporting by GI grid of 38 x 25 x 1.5 mm and cross tie of 25 x 25 x 1.5 mm and GI angle of 25 x 25 x 1.5 mm., for all heights, as per specifications, drawings and as directed by engineer-in-charge.	Sqm	41.00	638.51	26178.93
43	Providing and fixing aluminium work for doors, windows, ventilators and partitions with extruded built up standard tubular sections/ appropriate Z sections and other sections of approved make conforming to IS: 733 and IS: 1285, fixing with dash fasteners of required dia and size, including necessary filling up the gaps at junctions, i.e. at top, bottom and sides with required EPDM rubber/ neoprene gasket etc. Aluminium sections shall be smooth, rust free, straight, mitred and jointed mechanically wherever required including cleat angle, Aluminium snap beading for glazing / paneling, C.P. brass / stainless steel screws, all complete as per architectural drawings and the directions of Engineer-in-charge. (Glazing, paneling and dash fasteners to be paid for separately) : <b>Anodised aluminium (anodised transparent or dyed to required shade according to IS: 1868, Minimum anodic coating of grade AC 25)</b>	kg	490.00	290.51	142347.74

**UNPRICED PRICE BID**

**Construction of RCC Control Room buildings and other associated works for 5 MW floating Solar PV power plant for WBPDC, SAGARDIGHI at West Bengal".**

Sl. No.	Description of Work	Unit	Qty.	ITEM RATE (Excluding GST)	Amount
44	For shutters of doors, windows & ventilators including providing and fixing hinges/ pivots and making provision for fixing of fittings wherever required including the cost of EPDM rubber / neoprene gasket required (Fittings shall be paid for separately) <b>Anodised aluminium (anodised transparent or dyed to required shade according to IS: 1868, Minimum anodic coating of grade AC 25)</b>	kg	201.00	337.91	67919.27
45	Providing and fixing 12 mm thick prelaminated particle board flat pressed three layer or graded wood particle board conforming to IS: 12823 Grade I Type II, in panelling fixed in aluminum doors, windows shutters and partition frames with C.P. brass / stainless steel screws etc. complete as per architectural drawings and directions of Engineer-in-charge. Pre-laminated particle board with decorative lamination on both sides	sqm	54.00	686.35	37062.75
46	Providing and fixing glazing in aluminium door, window, ventilator shutters and partitions etc. with EPDM rubber / neoprene gasket etc. complete as per the architectural drawings and the directions of Engineer-in-charge . (Cost of aluminium snap beading shall be paid in basic item): With float glass panes of 4.0 mm thickness	sqm	23.00	587.27	13507.16
47	Providing and fixing glazing in aluminium door, window, ventilator shutters and partitions etc. with EPDM rubber / neoprene gasket etc. complete as per the architectural drawings and the directions of Engineer-in-charge . (Cost of aluminium snap beading shall be paid in basic item): With float glass panes of 6.00 mm thickness	sqm	49.00	795.13	38961.29
48	Providing and fixing anodised aluminium grill (anodised transparent or dyed to required shade according to IS: 1868 with minimum anodic coating of grade AC 15) of approved design/pattern, with approved standard section and fixed to the existing window frame with C.P. brass/ stainless steel screws @ 200 mm centre to centre, including cutting the grill to proper opening size for fixing and operation of handles and fixing approved anodised aluminium standard section around the opening, all complete as per requirement and direction of Engineer-in-charge. (Only weight of grill to be measured for payment).	kg	126.00	323.81	40799.96
49	Providing and fixing aluminium tower bolts, ISI marked, anodised (anodic coating not less than grade AC 10 as per IS : 1868 ) transparent or dyed to required colour or shade, with necessary screws etc. complete : 300x10 mm	each	4.00	78.96	315.85
50	Providing and fixing aluminium tower bolts, ISI marked, anodised (anodic coating not less than grade AC 10 as per IS : 1868 ) transparent or dyed to required colour or shade, with necessary screws etc. complete : 250x10 mm	each	9.00	69.78	627.98
51	Providing and fixing aluminium handles, ISI marked, anodised (anodic coating not less than grade AC 10 as per IS : 1868) transparent or dyed to required colour or shade, with necessary screws etc. complete : 125 mm	each	28.00	40.47	1133.19
52	Providing and fixing aluminium sliding door bolts, ISI marked anodised (anodic coating not less than grade AC 10 as per IS : 1868), transparent or dyed to required colour or shade, with nuts and screws etc. complete : 300x16	each	7.00	168.26	1177.82
53	Providing and fixing aluminium hanging floor door stopper, ISI marked, anodised (anodic coating not less than grade AC 10 as per IS : 1868) transparent or dyed to required colour and shade, with necessary screws etc. complete. Single rubber stopper	each	10.00	21.82	218.20
54	Providing and fixing bright finished brass 100 mm mortice latch and lock, ISI marked, with six levers and a pair of anodised (anodic coating not less than grade AC 10 as per IS : 1868) aluminium lever handles of approved quality with necessary screws etc. complete.	each	6.00	492.74	2956.46
55	Providing and fixing aluminium extruded section body tubular type universal hydraulic door closer (having brand logo with IS : 3564, embossed on the body, door weight upto 36 kg to 80 kg and door width from 701 mm to 1000 mm), with double speed adjustment with necessary accessories and screws etc. complete.	each	10.00	307.61	3076.13
56	Providing and fixing 100mm brass locks (best make of approved quality) for aluminium doors including necessary cutting and making good etc. complete as per direction of Engineer In-Charge.	Each	5.00	284.33	1421.64
57	18 mm thick moulded cement mortar band in two coats under layer 12 mm thick with cement mortar 1:5 (1 cement : 5 coarse sand) top layer 6 mm thick with cement mortar 1:4 (1 cement : 4 fine sand).	cm per m	378.00	7.60	2874.01
58	Providing gola 75x75 mm in cement concrete 1:2:4 (1 cement : 2 coarse sand : 4 stone aggregate 10 mm and down gauge), including finishing with cement mortar 1:3 (1 cement : 3 fine sand) as per standard design : In 75x75 mm deep chase	meter	116.00	121.18	14056.42

**UNPRICED PRICE BID**

**Construction of RCC Control Room buildings and other associated works for 5 MW floating Solar PV power plant for WBPDC, SAGARDIGHI at West Bengal".**

Sl. No.	Description of Work	Unit	Qty.	ITEM RATE (Excluding GST)	Amount
59	Diluting and injecting chemical emulsion for POST- CONSTRUCTIONAL anti-termite treatment (including the cost of chemical emulsion) :Treatment of soil under existing floors using chemical emulsion @ one litre per hole, 300 mm apart including drilling 12 mm diameter holes and plugging with cement mortar 1 :2 (1 cement : 2 Coarse sand) to match the existing floor: With Chlorpyrifos/Lindane E.C. 20% with 1% concentration	sqm	740.00	693.55	513230.26
60	Providing and fixing on wall face unplasticised Rigid PVC rain water pipes conforming to IS : 13592 Type A, including jointing with seal ring conforming to IS : 5382, leaving 10 mm gap for thermal expansion, (i) Single socketed pipes. 110 mm diameter	meter	54.00	187.19	10108.22
61	Providing and fixing on wall face unplasticised - PVC moulded fittings/accessories for unplasticised Rigid PVC rain water pipes conforming to IS : 13592 Type A, including jointing with seal ring conforming to IS : 5382, leaving 10 mm gap for thermal expansion. Shoe (Plain) 110 mm Shoe	each	10.00	77.62	776.16
62	Providing and laying in situ five course water proofing treatment with APP (Atactic Polypropylene) modified Polymeric memberane over roof consisting of first coat of bitumen primer @ 0.40Kg per sqm, 2nd & 4th courses of bonding material @ 1.20 kg/sqm, which shall consist of blown type bitumen of grade 85/25 conforming to IS : 702, 3rd layer of roofing membrane APP modified Polymeric membrane 2.0 mm thick of 3.00 Kg/ sqm weight consisting of five layers prefabricated with centre core as 100 micron HMHDPE film sandwiched on both sides with polymeric mix and the polymeric mix is protected on both side with 20 micron HMHDPE film. 5th, the top most layer shall be finished with brick tiles of class designation 10 grouted with cement mortar 1:3 (1 cement : 3 fine sand) mixed with 2% integral water proofing compound by weight of cement over a 12 mm layer of cement mortar 1:3 (1 cement : 3 fine sand) and finished neat (item of laying brick tiles shall be paid for separately).	sqm	709.00	254.63	180531.25
63	Providing and laying brick tiles over mummy roofs, grouted with cement mortar 1:3 (1 cement : 3 fine sand) mixed with 2% of integral water proofing compound by weight of cement, over 12 mm layer of cement mortar 1:3 (1 cement : 3 fine sand) and finished neat: With common burnt clay F.P.S. (non modular) brick tiles of class designation 10	sqm	1341.00	337.95	453186.12
64	Steel reinforcement for R.C.C. work including straightening, cutting, bending, placing in position and binding all complete upto all level. Thermo-Mechanically Treated bars of grade Fe-500D or more.	kg	31944.00	44.83	1431960.08
65	Making plinth protection 75mm thick of cement concrete 1:3:6 (1 cement : 3 coarse sand : 6 graded stone aggregate 20 mm nominal size) over 75mm thick bed of dry brick ballast 40 mm nominal size, well rammed and consolidated and grouted with fine sand, including necessary excavation, levelling & dressing & finishing the top smooth.	sqm	118.00	356.68	42087.91
66	Structural steel work riveted, bolted or welded in built up sections, trusses and framed work, including cutting, hoisting, fixing in position and applying a priming coat of approved steel primer all complete.	kg	3776.00	53.54	202164.02
67	Steel work welded in built up sections/ framed work, including cutting, hoisting, fixing in position and applying a priming coat of approved steel primer using structural steel etc. as required. In stringers, treads, landings etc. of stair cases, including use of chequered plate wherever required, all complete	kg	2999.00	52.11	156288.69
68	Painting with synthetic enamel paint of approved brand and manufacture to give an even shade : Two or more coats on new work	sqm	200.00	62.09	12418.56
69	Random rubble masonry with hard stone in foundation and plinth including levelling up with cement concrete 1:6:12 (1 cement : 6 coarse sand : 12 graded stone aggregate 20 mm nominal size) upto plinth level with : Cement mortar 1:6 (1 cement : 6 coarse sand)	cum	5.00	3140.95	15704.77
70	Providing and laying damp-proof course 40mm thick with cement concrete 1:2:4 (1 cement : 2 coarse sand (zone-III): 4 graded stone aggregate 12.5mm nominal size) Extra for providing and mixing water proofing material in cement concrete work in doses by weight of cement as per manufacturer's specification. Providing & applying a coat of residual petroleum bitumen of grade of VG-10 of approved quality using 1.7kg per square metre on damp proof course after cleaning the surface with brushes and finally with a piece of cloth lightly soaked in kerosene oil.	sqm	26.00	395.09	10272.32

**UNPRICED PRICE BID**

**Construction of RCC Control Room buildings and other associated works for 5 MW floating Solar PV power plant for WBPDC, SAGARDIGHI at West Bengal".**

Sl. No.	Description of Work	Unit	Qty.	ITEM RATE (Excluding GST)	Amount
71	Providing and fixing PVC pipes for cable entry conforming to IS 4985 of SWR quality 4 Kg & 6 Kg / Sq cm, pressure. The rate shall include cost of all fittings like plain elbow, plain tee, plain Y, 4 way tee and all required necessary specials etc., complete. jointing with rubber ring and solvent joints providing MS brackets grouted in the wall and fasteners cutting and making good the walls and floors (pipes running expose in sanitary ducts) supreme or prince quality pipes. <b>150mm</b> dia complete as per direction of Engineer In-Charge.	RM	50.00	117.91	5895.45
72	Providing and fixing white vitreous china pedestal type water closet (European type W.C. pan) with seat and lid, 10 litre low level white P.V.C. flushing cistern, including flush pipe, with manually controlled device (handle lever), conforming to IS : 7231, with all fittings and fixtures complete, including cutting and making good the walls and floors wherever required :W.C. pan with ISI marked white solid plastic seat and 390 mm high with lid complete as per direction of Engineer In-Charge.	Each	2.00	2707.61	5415.22
73	Providing and fixing approved quality paper holder fix on wall with rawl plugs all materials labours etc., all complete as directed by the Engineer-in-charge.C.P. brass	Each	2.00	305.20	610.39
74	Providing and fixing white vitreous china flat back or wall corner type lipped front urinal basin of 430x260x350 mm and 340x410x265 mm sizes respectively with automatic flushing cistern with standard flush pipe and C.P. brass spreaders with brass unions and G.I clamps complete, including painting of fittings and brackets, cutting and making good the walls and floors wherever required :One urinal basin with 5 litre white P.V.C. automatic flushing cistern complete as per direction of Engineer In-Charge.	Each	2.00	2767.37	5534.73
75	Providing and fixing wash basin with C.I. brackets, 15 mm C.P. brass pillar taps, 32 mm C.P. brass waste of standard pattern, including painting of fittings and brackets, cutting and making good the walls wherever require: White Vitreous China Wash basin size 550x400 mm with a pair of 15 mm C.P. brass pillar taps	Each	2.00	1659.48	3318.96
76	Providing and fixing 600x450 mm beveled edge mirror of superior glass (of approved quality) complete with 6 mm thick hard board ground fixed to wooden cleats with C.P. brass screws hard board backing complete as per direction of Engineer In-Charge.and washers complete.	Each	2.00	647.82	1295.63
77	Providing and fixing PTMT TOWEL RAIL complete with brackets fixed to wooden cleats with CP brass screws with concealed fittings arrangement of approved quality and colour. brass towel rail 600mm long and 20 dia mm with C.P. brass brackets complete as per direction of Engineer In-Charge.	Each	4.00	334.78	1339.11
78	Providing and fixing approved quality liquid soap dispenser and holder fix on wall with rawl plugs all materials labours etc., all complete as directed by the Engineer-in-charge.	Each	2.00	73.69	147.38
79	Providing and fixing approved brands of three layered Sintex Water tank-PVC water tanks including,lifting, positioning and cost of all labours, materials, fittings etc.complete as per direction of Engineer In-Charge.-(2000L each)	ltrs	1000.00	7.37	7371.00
80	Providing and fixing <b>PVC, soil waste and vent pipes</b> conforming to IS 4985 of SWR quality 4 Kg & 6 Kg / Sq cm, pressure. The rate shall include cost of all fittings like plain elbow, plain tee, plain Y, 4 way tee and all required necessary specials etc., complete. jointing with rubber ring and solvent joints providing MS brackets grouted in the wall and fasteners cutting and making good the walls and floors (pipes running expose in sanitary ducts) supreme or prince quality pipes. <b>75 mm</b> dia complete as per direction of Engineer In-Charge.	RM	10.00	73.69	736.92
81	Providing and fixing <b>PVC, soil waste and vent pipes</b> conforming to IS 4985 of SWR quality 4 Kg & 6 Kg / Sq cm, pressure. The rate shall include cost of all fittings like plain elbow, plain tee, plain Y, 4 way tee and all required necessary specials etc., complete. jointing with rubber ring and solvent joints providing MS brackets grouted in the wall and fasteners cutting and making good the walls and floors (pipes running expose in sanitary ducts) supreme or prince quality pipes. <b>110 mm</b> dia complete as per direction of Engineer In-Charge.	RM	60.00	95.81	5748.30
82	Providing and fixing <b>PVC, soil waste and vent pipes</b> conforming to IS 4985 of SWR quality 4 Kg & 6 Kg / Sq cm, pressure. The rate shall include cost of all fittings like plain elbow, plain tee, plain Y, 4 way tee and all required necessary specials etc., complete. jointing with rubber ring and solvent joints providing MS brackets grouted in the wall and fasteners cutting and making good the walls and floors (pipes running expose in sanitary ducts) supreme or prince quality pipes. <b>150 mm</b> dia complete as per direction of Engineer In-Charge.	RM	10.00	117.91	1179.09

**UNPRICED PRICE BID**

**Construction of RCC Control Room buildings and other associated works for 5 MW floating Solar PV power plant for WBPDC, SAGARDIGHI at West Bengal".**

Sl. No.	Description of Work	Unit	Qty.	ITEM RATE (Excluding GST)	Amount
83	Providing and fixing <b>High-density polyethylene (HDPE) pipes</b> , including all HDPE pipes & fittings, trenching, refilling & testing of joints complete as per direction of Engineer in Charge. <b>75 mm</b> nominal inner dia Pipes.	meter	5.00	951.23	4756.16
84	Providing and fixing <b>High-density polyethylene (HDPE) pipes</b> , including all HDPE pipes & fittings, trenching, refilling & testing of joints complete as per direction of Engineer in Charge. <b>100 mm</b> nominal inner dia Pipes.	meter	5.00	1281.54	6407.68
85	Providing and fixing <b>High-density polyethylene (HDPE) pipes</b> , including all HDPE pipes & fittings, trenching, refilling & testing of joints complete as per direction of Engineer in Charge. <b>150 mm</b> nominal inner dia Pipes.	meter	5.00	1907.73	9538.65
86	Providing & fixing 100 mm PVC for gully, floor or nahani trap at all heights and levels complete as per direction of Engineer In-Charge.	Each	6.00	515.87	3095.23
87	Providing and fixing gun metal gate valve with C.I. wheel of approved quality (screwed end) :25 mm nominal bore complete as per direction of Engineer In-Charge.	Each	6.00	339.13	2034.81
88	Providing and fixing gun metal gate valve with C.I. wheel of approved quality (screwed end) :50 mm nominal bore complete as per direction of Engineer In-Charge.	Each	2.00	593.92	1187.84
89	Providing and fixing brass stop cock of approved design, quality and make 15mm NB complete as per direction of Engineer In-Charge.	Each	5.00	206.00	1030.00
90	Providing and fixing brass stop cock of approved design, quality and make 20mm NB complete as per direction of Engineer In-Charge.	Each	5.00	222.08	1110.38
91	Providing and fixing <b>Chlorinated Polyvinyl Chloride (CPVC) pipes</b> , having thermal stability for hot & cold water supply, including all CPVC plain & brass threaded fittings, i/c fixing the pipe with clamps at 1.00 m spacing. This includes jointing of pipes & fittings with one step CPVC solvent cement and the cost of cutting chases and making good the same including testing of joints complete as per direction of Engineer in Charge. Concealed work, including cutting chases and making good the walls etc. <b>15 mm</b> nominal outer dia Pipes	meter	10.00	194.99	1949.90
92	Providing and fixing <b>Chlorinated Polyvinyl Chloride (CPVC) pipes</b> , having thermal stability for hot & cold water supply, including all CPVC plain & brass threaded fittings, i/c fixing the pipe with clamps at 1.00 m spacing. This includes jointing of pipes & fittings with one step CPVC solvent cement and the cost of cutting chases and making good the same including testing of joints complete as per direction of Engineer in Charge. Concealed work, including cutting chases and making good the walls etc. <b>20 mm</b> nominal outer dia Pipes	meter	30.00	225.60	6768.04
93	Providing and fixing <b>Chlorinated Polyvinyl Chloride (CPVC) pipes</b> , having thermal stability for hot & cold water supply, including all CPVC plain & brass threaded fittings, i/c fixing the pipe with clamps at 1.00 m spacing. This includes jointing of pipes & fittings with one step CPVC solvent cement and the cost of cutting chases and making good the same including testing of joints complete as per direction of Engineer in Charge. Concealed work, including cutting chases and making good the walls etc. <b>25 mm</b> nominal outer dia Pipes	meter	30.00	264.21	7926.34
94	Providing and fixing <b>unplasticized polyvinyl chloride (uPVC) pipes</b> , including all uPVC plain & brass threaded fittings, including fixing the pipe with clamps at 1.00 m spacing. This includes jointing of pipes & fittings with one step uPVC solvent cement and testing of joints complete as per direction of Engineer in Charge. Internal work - Exposed on wall. <b>15 mm</b> nominal outer dia Pipes.	meter	10.00	113.22	1132.16
95	Providing and fixing <b>unplasticized polyvinyl chloride (uPVC) pipes</b> , including all uPVC plain & brass threaded fittings, including fixing the pipe with clamps at 1.00 m spacing. This includes jointing of pipes & fittings with one step uPVC solvent cement and testing of joints complete as per direction of Engineer in Charge. Internal work - Exposed on wall. <b>20 mm</b> nominal outer dia Pipes.	meter	30.00	142.52	4275.61
96	Providing and fixing <b>unplasticized polyvinyl chloride (uPVC) pipes</b> , including all uPVC plain & brass threaded fittings, including fixing the pipe with clamps at 1.00 m spacing. This includes jointing of pipes & fittings with one step uPVC solvent cement and testing of joints complete as per direction of Engineer in Charge. Internal work - Exposed on wall. <b>25 mm</b> nominal outer dia Pipes.	meter	30.00	171.23	5136.91
97	Providing and fixing <b>unplasticized polyvinyl chloride (uPVC) pipes</b> , including all uPVC plain & brass threaded fittings, including fixing the pipe with clamps at 1.00 m spacing. This includes jointing of pipes & fittings with one step uPVC solvent cement and testing of joints complete as per direction of Engineer in Charge. Internal work - Exposed on wall. <b>50 mm</b> nominal outer dia Pipes.	meter	10.00	434.45	4344.52

**UNPRICED PRICE BID****Construction of RCC Control Room buildings and other associated works for 5 MW floating Solar PV power plant for WBPDC, SAGARDIGHI at West Bengal".**

Sl. No.	Description of Work	Unit	Qty.	ITEM RATE (Excluding GST)	Amount
98	Providing and fixing G.I. Pipes complete with G.I. fittings and clamps, i/c making good the walls etc. concealed pipe, including painting with anti corrosive bitumastic paint, cutting chases and making good the wall 15 mm dia nominal bore	meter	10.00	226.27	2262.74
99	Providing and fixing G.I. Pipes complete with G.I. fittings and clamps, i/c making good the walls etc. concealed pipe, including painting with anti corrosive bitumastic paint, cutting chases and making good the wall :20 mm dia nominal bore	meter	30.00	250.43	7512.91
100	Providing and fixing G.I. pipes complete with G.I. fittings and clamps, i/c cutting and making good the walls etc. Internal work - Exposed on wall 15 mm dia nominal bore	meter	10.00	147.63	1476.29
101	Providing and fixing G.I. pipes complete with G.I. fittings and clamps, i/c cutting and making good the walls etc. Internal work - Exposed on wall 20 mm dia nominal bore	meter	30.00	177.53	5325.80
102	Providing and fixing G.I. pipes complete with G.I. fittings including trenching and refilling etc. 25 mm dia nominal bore	meter	30.00	163.03	4891.00
103	Providing and fixing G.I. pipes complete with G.I. fittings including trenching and refilling etc. 50 mm dia nominal bore	meter	10.00	271.42	2714.18
104	Providing and fixing brass bib cock of approved quality: 15 mm nominal bore complete as per direction of Engineer In-Charge.	Each	8.00	206.00	1647.99
105	Providing and fixing brass bib cock of approved quality 20 mm nominal bore complete as per direction of Engineer In-Charge.	Each	8.00	222.08	1776.61
106	Providing and fixing brass stop cock of approved design, quality and make 15mm NB complete as per direction of Engineer In-Charge.	Each	8.00	206.00	1647.99
107	Providing and fixing brass stop cock of approved design, quality and make 20mm NB complete as per direction of Engineer In-Charge.	Each	8.00	222.08	1776.61
108	Providing and fixing vista make vertical blind of approved color and brand cost is including of supply of materials, fixing, labour charges, transportation all leads, lifts, taxes etc. complete at all height and levels complete as per direction of Engineer In-Charge.	Sqm	23.00	626.42	14407.61
<b>TOTAL AMOUNT: (A) Civil works</b>					<b>Rs. 8,893,013.19</b>

**UNPRICED PRICE BID**

**Construction of RCC Control Room buildings and other associated works for 5 MW floating Solar PV power plant for WBPDC, SAGARDIGHI at West Bengal".**

Sl. No.	Description of Work	Unit	Qty.	ITEM RATE (Excluding GST)	Amount
---------	---------------------	------	------	---------------------------	--------

**(B) Electrical works**

SL no:	Description of Work	Unit	Qty.	ITEM RATE (Excluding GST)	Amount
109	LED indoor luminaire, industrial grade with diffuser and heat sink, minimum 3-star BEE rating, 30W, 240V, Philips/ Syska/ Havells/ Wipro/ Bajaj/ Crompton make as per LM79-08 & LM80-15 standards as approved by SCCL/BHEL	Nos	50.00	3316.33	165816.45
110	LED indoor luminaire, industrial grade with diffuser and heat sink, minimum 3-star BEE rating, 10W, 240V, Philips/ Syska/ Havells/ Wipro/ Bajaj/ Crompton make as per LM79-08 & LM80-15 standards as approved by SCCL/BHEL	Nos	20.00	1105.44	22108.86
111	LED bulkhead luminaire around the building (on the outer walls), 9W, 240V, minimum 3-star BEE rating, Philips/ Syska/ Havells/ Wipro/ Bajaj/ Crompton make as per LM79-08 & LM80-15 standards as approved by SCCL/BHEL	Nos	30.00	147.39	4421.79
112	Ceiling fan 1200 mm sweep 5 star type Khaitan/ Usha/ Bajaj/ Crompton/ Havells make as approved by SCCL/BHEL	Nos	10.00	2579.37	25793.73
113	Fan regulator Modular type of reputed make as approved by SCCL/BHEL	Nos	10.00	184.24	1842.39
114	6A modular type switch of reputed make as approved by SCCL/BHEL	Nos	150.00	110.55	16582.05
115	6A, 1ph, 5 pin, switched socket outlet Modular type of reputed make as approved by SCCL/BHEL	Nos	10.00	110.55	1105.47
116	16A, 1ph, 5 pin, switched socket outlet Module type of reputed make as approved by SCCL/BHEL	Nos	20.00	221.09	4421.70
117	3x6A, 1ph, 5 (2-3) pin socket outlet controlled by one 16A switch of reputed make as approved by SCCL/BHEL	Nos	10.00	368.48	3684.78
118	25A, 1ph, 5 pin, industrial socket with MCB enclosure of reputed make as approved by SCCL/BHEL	Nos	10.00	257.94	2579.40
119	63A, 3ph, 415V, industrial socket with MCB enclosure of reputed make as approved by SCCL/BHEL	Nos	2.00	361.85	723.69
120	Exhaust fan 450mm of reputed make as approved by SCCL/BHEL	Nos	12.00	7001.15	84013.74
121	Power distribution board of reputed make as approved by SCCL/BHEL	Nos	2.00	5527.22	11054.45
122	Cables, cable conduits, cable accessories for the above, all conduits (Embedded in wall or floor) shall be 1" pvc pipe (dia) of reputed make as approved by SCCL/BHEL	Mtr	500.00	29.48	14742.00
123	4CX25 Sq mm Cu Cable of reputed make as approved by SCCL/BHEL	Mtr	50.00	331.63	16581.60

**TOTAL AMOUNT: (B) Electrical works**

**Rs. 375,472.10**

Activities	Summary of the activities	
A	Civil works	Rs. 8,893,013.19
B	Electrical works	Rs. 375,472.10
Total value of the works (rounded off)		<b>Rs. 9,268,485.29</b>
QUOTE PERCENTAGE (%) ABOVE/BELOW (+/-) (OR) AT PAR TO TOTAL AMOUNT		XXXXXXXXXX
QUOTED PERCENTAGE (%) IN WORDS ABOVE/BELOW (OR) AT PAR TO TOTAL AMOUNT		XXXXXXXXXX
Plus applicable GST		

**NOTE:**

- CONTRACTOR SHOULD QUOTE PERCENTAGE (%) ABOVE/BELOW (OR) AT PAR TO TOTAL AMOUNT
- QUOTED PERCENTAGE (%) IS APPLICABLE ON ALL ITEM RATES UNIFORMLY.

## **TECHNICAL AND GENERAL SPECIFICATION**

### **1.0 CONTROL BUILDING:**

Control Room building is required to be constructed for housing the electrical equipment/ panel, HT LT Switchgears and office cum store room and other daily requirements for the operation & maintenance of Solar Photovoltaic Power Plant. The building shall be constructed with conventional RCC framed structure with brick partition walls for equipment and operations room. Equipment room shall be designed as per the OEM recommendations to ensure desired life of equipment. Operation room shall be with Air conditioned environment. Bidder shall furnish the drawing of the proposed buildings to the Employer for approval, prior to construction. The construction of the same shall be as under-

### **2.0 EQUIPMENT ROOM LAYOUT:**

Flexibility shall be kept for handling of equipment without obstruction both during erection and maintenance. Adequate handling facilities, space, door/rolling shutter of adequate width and height shall be provided for the purpose. The followings specification shall be followed for designing the Equipment cum Control Building:

- a) Minimum clearance between two switchgear panels, facing each other shall be maintained as 2200 mm. These distances shall be maintained for all other panels located inside the room.
- b) Clearance from any obstruction like column, wall, and vertical raceway on back side of switchgears shall be maintained as 1200mm (minimum) for single front panel / 1500mm (minimum) for double front panel and shall also comply with manufacture's standard. Minimum Space between the sides of two switchgears or between any two panels or between switchgear and the wall shall be 1200 mm. Where access is not envisaged, clearance shall be 200 mm.
- c) All electrical room shall be provided with 2 doors in addition to the shutters provided for handling transformer, switchgear, panels etc.
- d) Switchgear room/MCC/Control room shall be pressurized above the atmospheric pressure to prevent ingress of dust.
- e) Switchgear/MCC room shall have a minimum clear height of 5 m above floor level. All electrical equipment shall be located above the highest flood level. Cable cellar room shall be located above around to prevent ingress of water inside.
- f) Control room shall be separated from switchgear /MCC room.

### **3.0 RCC WORKS**

All RCC works shall be as per IS 456 and the materials used viz. Cement, reinforcement steel etc. shall be as per relevant standards.

### **4.0 BRICK WORKS**

NIT Issued By



Mowleeswaran Natesan,  
Dy. Manager-Civil, BHEL-EDN

CONTACTOR (SIGN & SEAL)

Brick works in cement mortar (CM) 1:6 for 9" thick and 4½" thick wall respectively. All brick works shall be using 1st class bricks of approved quality as per IS 3102.

## **5.0 DOORS & WINDOWS**

Steel framed doors, Windows and ventilators shall conform to IS – 1081 with necessary glass panels including of all fixtures and painting etc. complete. Doors and windows shall be made of aluminum sections. All sections shall be 20 microns anodized. Sections of door frame and window frame shall be adopted as per industrial standards. Door shutters shall be made of aluminum sections and combination of compact sheet and clear float/ wired glass. The control room shall require a number of windows/ louvers to provide ventilation/ fresh air circulations.

## **6.0 PLASTERING**

Plastering in cement mortar 1:5, 1:6 and 1:3 shall be applied to all internal, external walls and ceiling of slab respectively as per IS 1542.

## **7.0 FLOORING**

Flooring shall be of cement flooring in concrete mix 1:2:4 using 10 mm aggregates as per IS 2571. Flooring for control room, equipment room and other places, shall be of vitrified tiles 8 mm. For toilet area, the floor shall be of ceramic tiles 8 mm thicknesses. The floor finishing must include skirting up to a suitable height. The wall tiles, if proposed, shall be glazed tiles of 6 mm thickness and provided up to lintel level.

## **8.0 ROOFING**

The roof of the building shall be insulated and waterproofing shall be done as per relevant IS standard.

## **9.0 PLINTH PROTECTION**

Plinth protection 1000mm wide shall be provided around all the buildings.

## **10.0 WHITE WASHING & COLOUR WASHING**

White washing and colour washing work shall be conforming to IS 6278.

Internal walls - Acrylic distempering as per IS 427.

External walls – Heat reflective synthetic enamel as per IS 428.

For cement painting IS 5410 shall be followed.

For painting of steel doors, ventilators IS 2338, IS 1477 (Part I & II) shall be followed.

## **11.0 ROLLING SHUTTERS**

Rolling shutters made of cold rolled strips shall conforming to IS 4030 with approved gauge thickness shall be provided with all fixtures, accessories, painting all etc. complete.

NIT Issued By



Mowleeswaran Natesan,  
Dy. Manager-Civil, BHEL-EDN

CONTACTOR (SIGN & SEAL)

## **12.0 WATER SUPPLY**

GI pipes of Medium quality conforming to IS 1239 (Part I) and IS 1795 for Mild Steel pipes shall be used for all water supply and plumbing works.

## **13.0 PLUMBING AND SANITARY**

Sanitary fittings, which include water closet (EWC/IWC), wash basins, sink, urinal fitting including flushing tank, and necessary plumbing lines shall be provided for office cum stores building and Security house.

## **14.0 ELECTRIFICATION OF BUILDING**

Electrification of buildings shall be carried out as per IS 732 and other relevant standards. The lighting design of the buildings shall be carried out as per IS 3646. The building shall be provided with adequate quantity of light fittings, 5A/15A 1 phase sockets; fans etc., controlled by required ratings of MCBs and DBs. Operation room 7 PLC room must be fitted with suitably sized HVAC system. It is encouraged that bidder shall use the latest energy efficient equipment for the electrification and illumination.

## **15.0 TOILET**

Toilet shall be designed for 5 persons; and constructed with following finish

- Floor: Vitrified tiles/ ceramic tiles
- Door window: made out of aluminium sections, 6mm float glass
- Ventilators: Mechanical exhaust facility
- Plumbing fixtures: Repute make
- Sanitary ware: Repute make
- EWC: 390 mm high with health facet, toilet paper roll holder and all fittings
- Urinal (430 x 260 x 350 mm size) with all fittings.
- Wash basin (550 x 400 mm) with all fittings.
- Bathroom mirror (600 x 450 x 6 mm thick) hard board backing
- CP brass towel rail (600 x 20 mm) with C.P. brass brackets
- Soap holder and liquid soap dispenser.
- GI pipes (B class) of reputed makes
- Overhead water tank equivalent of 700 litre capacity

## **16.0 Drainage for Toilets:**

Drainage pipes shall be of PVC (6 kg/cm<sup>2</sup>) Supreme, Prince or equivalent make. Gully trap, inspection chambers, septic tank for 5 person and soak well to be constructed for abovementioned requirement.

## **17.0 WATER SUPPLY & CLEANING**

NIT Issued By



Mowleeswaran Natesan,  
Dy. Manager-Civil, BHEL-EDN

CONTACTOR (SIGN & SEAL)

Suitable arrangement of water shall be ensured to cater the day-to-day requirement of drinking water and other use of Control Room.

### **18.0PV ARRAY O&M MAINTENANCE ARRANGEMENT**

Equipments which are required for day to day cleaning of the solar panels and for O&M of the solar plant shall be in the scope of the bidders and accordingly the bidder has to provide all the necessary equipments, accessories, tool & tackles, boat, piping arrangement which as may be required for the same. Bidder shall have to provide a paddle boat for O&M operation with carrying capacity of four persons.

### **19.0 APPROCH ROAD FOR SOLAR POWER PLANT**

Suitable approach road from Control Building to Solar Plant to carry safe and easy transportation of equipment and material at the project site shall be made. The road should provide easy and fast approach to each location of the plant. Roads are to be constructed with sufficient width (minimum 3.75m) followed by 0.5m well compacted shoulders on each side. The road must be well compacted as per the relevant IS standards and MORTH updated till date. All peripheral roads and pathways from central road to Inverter room road shall be WBM road. Also, all cable crossings and other crossings shall be provided with GI/ Hume pipes.

### **20.0 WATCHMEN / SECURITY CABIN**

Contractor shall provide adequate numbers of prefabricated Watchman's portable cabin at strategic locations surrounding of the plant. The Minimum size of watchmen's (Security Cabin) cabin is 1.2 metre x 1.8 metre size and height of 2.4m with appropriate roof at the top. Location of the watch Cabin (Security Cabin) will be as directed by the Purchaser. The Prefabricated Security Cabin of size 3 metre x 3 metre at the main entrance gate shall be designed and constructed by the Successful Bidder keeping in view the safety and security of the power plant.

### **21.0 Field Quality Plan**

Well before the start of the work, the contractor shall prepare and submit the Field Quality Plans to Employer for approval, which shall detail out for all the works, equipment, services, quality practices and procedures etc. in line with the requirement of the technical specifications to be followed by the contractor at site.

This FQP shall cover all the items / activities covered in the contract / schedule of items required, right from material procurement to completion of the work at site.

### **22.0General QA Requirements**

22.1 The contractor shall ensure that the works, BOIs and services under the scope of Contract, whether manufactured or performed within contractor's works or at his subcontractor's premises or at the project site or at any other place of work, are in accordance with Technical specification, applicable standards / codes, approved drawings / data sheets / quality plans and BOQ. All the works, BOIs and services shall be carried out as per the best prevalent engineering practices and to the directions of the Engineer.

NIT Issued By

CONTACTOR (SIGN & SEAL)



Mowleeswaran Natesan,  
Dy. Manager-Civil, BHEL-EDN

Equipment UOM	Approx. Qty.
Cube moulds for cement testing nos.	4
Sieve shaker nos.	1
Sieve for sand, coarse and fine aggregate set	1
Sieve for coarse aggregate set	1
Slump testing equipment nos.	6
Oven nos.	2
Physical balance nos.	1
Thermometer nos.	4
Burret nos.	2
Measuring cylinder nos.	9
Measuring flask nos.	3
Compression testing machine set	1
Cube mould for concrete nos.	10
Mechanical weighing machine nos. (100kg capacity)	1
Drum type concrete mixer (for trial mixes) nos.	1
Proctor testing equipment set	1

## 22.2 Notes

22.3 The equipment listed above is indicative and minimum required. Additional equipment, if any, required for successful completion of work shall be provided /arranged by the contractor.

22.4 All test reports/ inspection reports shall be submitted in soft copy also and shall be available at site for easy access to the Engineer.

22.5 Based on the schedule (L2/L3 Network), Quality control & Quality Assurance Work plan shall be finalized by the contractor and the same shall be submitted to Engineer for acceptance/approval.

## 23 PROTECTION OF WORK

The Contractor shall have total responsibility for protecting his works till it is finally taken over by the Employer. No claim will be entertained by the Employer or the representative of the Employer for any damage or loss to the Contractor's works and the Contractor shall be responsible for complete restoration of the damaged works to original conditions to comply with the specification and drawings. Should any such damage to the Contractor's Works occur because of other party not being under his supervision or control, the Contractor shall make his claim directly with the party Concerned.

If disagreement or conflict or dispute develops between the Contractor and the other party or parties concerned regarding the responsibility for damage to the Contractor's Works the same shall be rectified. The Contractor shall not cause any delay in the repair of such damaged Works because of any delay in the resolution of such disputes. The Contractor shall proceed to repair the Work immediately and no cause thereof will be assigned Pending resolution of such disputes.

## 24.0 EMPLOYMENT OF LABOUR

In addition to all local laws and regulations pertaining to the employment of labour to be complied with by the Contractor pursuant to GCC, the Contractor

NIT Issued By

CONTACTOR (SIGN & SEAL)

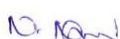

Mowleeswaran Natesan,  
Dy. Manager-Civil, BHEL-EDN

will be expected to employ on the work only his regular skilled employees with experience of the particular work. No female labour shall be employed after darkness. No person below the age of eighteen years shall be employed. All travelling expenses including provisions of all necessary transport to and from Site, lodging allowances and other payments to the Contractor's employees shall be the sole responsibility of the Contractor. The hours of work on the Site shall be decided by the Employer and the Contractor shall adhere to it. Working hours will normally be eight (8) hours per day - Monday through Saturday. Contractor's employees shall wear identification badges while on work at Site.

In case the Employer becomes liable to pay any wages or dues to the labour or any Government agency under any of the provisions of the Minimum Wages Act, Workmen Compensation Act, Contract Labour Regulation Abolition Act or any other law due to act of omission of the Contractor, the Employer may make such payments and shall recover the same from the Contractors Bills. Electricity and water shall be the responsibility of the contractor.

## **25.0 FACILITIES TO BE PROVIDED BY THE CONTRACTOR**

### **25.1 Contractor's site office Establishment**

The Contractor shall establish a site office at the site and keep posted unauthorized representative for the purpose of the contract, pursuant to GCC.

### **25.2 Tools, tackles and scaffoldings**

The Contractor shall provide all the construction equipment's, tools, tackles and scaffoldings required for pre-assembly, installation, testing, commissioning and conducting Guarantee tests of the equipment's covered under the Contract. He shall submit a list of all such materials to the

Employer before the commencement of pre-assembly at Site. These tools and tackles shall not be removed from the Site without the written permission of the Employer. The Contractor shall arrange Dozer, Hydra, Cranes, Trailer, etc. for the purpose of fabrication, erection and commissioning.

### **25.3 First-aid**

The Contractor shall provide necessary first-aid facilities for all his employees, representatives and workmen working at the Site. Enough number of Contractor's personnel shall be trained in administering first-aid. The Employer will provide the Contractor, in case of any emergency, the services of an ambulance for transportation to the nearest hospital.

### **25.4 Cleanliness**

a) The Contractor shall be responsible for keeping the entire area allotted to him clean and free from rubbish, debris etc. during the period of Contract. The Contractor shall employ enough number of special personnel to thoroughly clean his work-area at least once in a day. All such rubbish and scrap material shall be stacked or disposed in a place to be identified by the Employer. Materials and stores shall be so arranged to permit easy cleaning of the area. In areas where equipment might drip oil and cause damage to the floor surface, a suitable protective cover of a flame resistant, oil proof sheet shall be provided to protect the floor from such damage.

NIT Issued By



Mowleeswaran Natesan,  
Dy. Manager-Civil, BHEL-EDN

CONTACTOR (SIGN & SEAL)

b) Similarly the labour colony, the offices and the residential areas of the Contractor's employees and workmen shall be kept clean and neat to the entire satisfaction of the Employer. Proper sanitary arrangements shall be provided by the Contractor, in the work-areas, office and residential areas of the Contractor.

### **25.5 FIRE PROTECTION**

Required Fire Protection Measures are described under Clause titled

“**WORK & SAFETY REGULATIONS**” of this Sub-section.

### **25.6 SECURITY**

The Contractor shall have total responsibility for all equipment and materials in his custody stores, loose, semi-assembled and/or erected by him at Site. The Contractor shall make suitable security arrangements including employment of security personnel to ensure the protection of all materials, equipment and works from theft, fire, pilferage and any other damages and loss. All materials of the Contractor shall enter and leave the Employer Site only with the written permission of the Employer in the prescribed manner.

### **25.7 CONTRACTOR'S AREA LIMITS**

The Employer will mark-out the boundary limits of access roads, parking spaces, storage and construction areas for the Contractor and the Contractor shall not trespass the areas not so marked out for him. The Contractor shall be responsible to ensure that none of his personnel move out of the areas marked out for his operations. In case of such a need for the Contractor's personnel to work out of the areas marked out for him the same shall be done only with the written permission of the Employer.

### **25.8 CONTRACTOR'S CO-OPERATION WITH THE EMPLOYER**

In case where the performance of the erection work by the Contractor affects the operation of the system facilities of the Employer, such erection work of the Contractor shall be scheduled to be performed only in the manner stipulated by the Employer and the same shall be acceptable at all

times to the Contractor. The Employer may impose such restrictions on the facilities provided to the Contractor such as electricity, etc. as he may think fit in the interest of the Employer and the Contractor shall strictly adhere to such restrictions and co-operate with the Employer.

It will be the responsibility of the Contractor to provide all necessary temporary instrumentation and other measuring devices required during start-up and operation of the equipment systems which are erected by him. The Contractor shall also be responsible for flushing and initial filling of all the oil and lubricants required for the equipment furnished and installed by him, so as to make such equipment ready for operation. The Contractor shall be responsible for supplying such flushing oil and other lubricants unless otherwise specified elsewhere in documents and specifications

### **25.9 MATERIALS HANDLING AND STORAGE**

All the equipment's furnished under the Contract and arriving at Site shall be promptly received, unloaded and transported and stored in the storage spaces by the Contractor

NIT Issued By

CONTRACTOR (SIGN & SEAL)



Mowleeswaran Natesan,  
Dy. Manager-Civil, BHEL-EDN

.Contractor shall be responsible for examining all the shipment and notify the Employer immediately of any damage, shortage, discrepancy etc. for the purpose of Employer's information only. The Contractor shall submit to the Employer every week a report detailing all the receipts during the week.

However, the Contractor shall be solely responsible for any shortages or damage in transit, handling and /or in storage and erection of the equipment at Site. Any demurrage, wharf age and other such charges claimed by the transporters, railways etc. shall be to the account of the Contractor. The Contractor shall maintain an accurate and exhaustive record detailing out the list of all equipment received by him for the purpose of erection and keep such record open for the inspection of the Employer. All equipment shall be handled very carefully to prevent any damage or loss. No bare wire ropes, slings, etc. shall be used for unloading and/or handling of the equipment without the specific written permission of the Employer. The equipment stored shall be properly protected to prevent damage either to the equipment or to the floor where they are stored. The equipment from the store shall be moved to the actual location at the appropriate time so as to avoid damage of such equipment at Site.

The actual location at the appropriate time so as to avoid damage of such equipment at Site. The Contractor shall ensure that all the packing materials and protection devices used for the various equipment's during transit and storage are removed before the equipment are installed. The consumables and other supplies likely to deteriorate due to storage must be thoroughly protected and stored in a suitable manner to prevent damage or deterioration in quality by storage. All the materials stored in the open or dusty location must be covered with suitable Weather proof and flameproof covering material wherever applicable.

If the materials belonging to the Contractor are stored in areas other than those earmarked for him, the Employer will have the right to get it moved to the place earmarked for the Contractor at the Contractor's cost. The Contractor shall be responsible for making suitable indoor storage facilities to store all equipment which require indoor storage. Normally, all the electrical equipment's such as motors, control gear, generators, exciters and consumables like electrodes, lubricants etc. shall be stored in the closed storage space. The Employer, in addition, may direct the Contractor to move certain other materials, which in his opinion will require indoor storage, to indoor storage areas which the Contractor shall strictly comply with.

#### **25.10 CONSTRUCTION MANAGEMENT**

The field activities of the Contractors working at Site, will be coordinated by the Employer and the Employer decision shall be final in resolving any disputes or conflicts between the Contractor and other Contractors and tradesmen of the Employer regarding scheduling and co- ordination of work. Such decision by the Employer shall not be a cause for extra compensation or extension of time for the Contractor.

The Employer shall hold weekly meetings of all the Contractors working at Site, at time and place to be designated by the Employer. The Contractor shall attend such meetings and take notes of discussions during the meeting and the decisions of the Employer and shall

NIT Issued By

CONTACTOR (SIGN & SEAL)

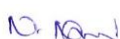

Mowleeswaran Natesan,  
Dy. Manager-Civil, BHEL-EDN

strictly adhere to those decisions in performing his Works. In addition to the above weekly meeting, the Employer may call for other meeting either with individual Contractors or with selected number of Contractors and in such a case the Contractor if called, will also attend such meetings. Time is the essence of the Contract and the Contractor shall be responsible for performance of his works in accordance with the specified construction schedule.

If at any time, the Contractor is falling behind the schedule, he shall take necessary action to make good for such delays by increasing his work force or by working overtime or otherwise accelerate the progress of the work to comply with the schedule and shall communicate such actions in writing to the Employer, satisfying that his action will compensate for the delay. The Contractor shall not be allowed any extra compensation for such action. The Employer shall however not be responsible for provision of additional labour and or materials or supply or any other services to the Contractor except for the co-ordination work between various Contractors as set out earlier.

#### **25.11 FIELD OFFICE RECORDS**

The Contractor shall maintain at his Site Office up-to- date copies of all drawings, specifications and other Contract Documents and any other supplementary data complete with all the latest revisions thereto. The Contractor shall also maintain in addition the continuous record of all changes to the above Contract Documents, drawings, specifications, supplementary data, etc. effected at the field and on completion of his total assignment under the Contract shall incorporate all such changes on the drawings and other Engineering data to indicate as installed conditions of the equipment furnished and erected under the Contract. Such drawings and Engineering data shall be submitted to the Employer in required number of copies.

#### **25.12 CONTRACTOR'S MATERIALS BROUGHT ON TO SITE**

The Contractor shall bring to Site all equipment, components, parts, materials, including construction equipment, tools and tackles for the purpose of the Works under intimation to the Employer. All such goods shall, from the time of their being brought vest in the Employer, but may be used for the purpose of the Works only and shall not on any account be removed or taken away by the Contractor without the written permission of the Employer. The Contractor shall nevertheless be solely liable and responsible for any loss or destruction thereof and damage thereto.

The Employer shall have a lien on such goods for any sum or sums which may at any time be due or owing to him by the Contractor, under, in respect of or by reasons of the Contract. After giving a fifteen (15) days' notice in writing of his intention to do so, the Employer shall be at liberty to sell and dispose off any such goods, in such manner as he shall think fit including public auction or private treaty and to apply the proceeds in or towards the satisfaction of such sum or sums due as aforesaid. After the completion of the Works, the Contractor shall remove from the Site under the direction of the Employer the materials such as construction equipment, erection tools and tackles, scaffolding etc. with

NIT Issued By

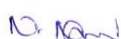

Mowleeswaran Natesan,  
Dy. Manager-Civil, BHEL-EDN

CONTACTOR (SIGN & SEAL)

the written permission of the Employer. If the Contractor fails to remove such materials, within fifteen (15) days of issue of a notice by the Employer to do so then the Employer shall have the liberty to dispose of such materials.

### **25.13 PROTECTION OF PROPERTY AND CONTRACTOR'S LIABILITY**

The Contractor shall be responsible for any damage resulting from his operations. He shall also be responsible for protection of all persons including members of public and employees of the Employer and the employees of other Contractors and Sub- Contractors and all public and private property including structures, building, other plants and equipment's and utilities either above or below the ground.

The Contractor will ensure provision of necessary safety equipment such as barriers, sign - boards, warning lights and alarms, etc. to provide adequate protection to persons and property. The Contractor shall be responsible to give reasonable notice to the Employer and the Employers of public or private property and utilities when such property and utilities are likely to get damaged or injured during the performance of his Works and shall make all necessary arrangements with such Employers, related to removal and/or replacement or protection of such property and utilities.

### **25.14 INSURANCE**

In addition to the conditions covered under the Clause entitled "Insurance" in Section General Conditions of Contract (GCC), the following provisions will also apply to the portion of works to be done beyond the Contractor's own or his Sub-Contractor's manufacturing Works.

### **25.15 Workmen's Compensation Insurance**

This insurance shall protect the Contractor against all claims applicable under the Workmen's Compensation Act, 1948 (Government of India). This policy shall also cover the Contractor against claims for injury, disability disease or death of his or his Sub-Contractor's employees, which for any reason are not covered under the Workmen's Compensation Act, 1948. The liabilities shall not be less than the following: Workmen's Compensation - As per Statutory Provisions Employee's Liability - As per Statutory Provisions

### **25.16 UNFAVOURABLE WORKING CONDITIONS**

The Contractor shall confine all his field operations to those works which can be performed without subjecting the equipment and materials to adverse effects during inclement weather conditions, like monsoon, storms, etc. and during other unfavourable construction conditions. No field activities shall be performed by the Contractor under conditions which might adversely affect the quality and efficiency thereof, unless special precautions or measures are taken by the Contractor in a proper and satisfactory manner in the performance of such Works and with the Concurrence of the Employer. Such unfavourable construction conditions will in no way relieve the Contractor of his responsibility to perform the Works as per the schedule.

### **25.17 PROTECTION OF MONUMENTS AND REFERENCE POINTS**

NIT Issued By

CONTACTOR (SIGN & SEAL)



Mowleeswaran Natesan,  
Dy. Manager-Civil, BHEL-EDN

The Contractor shall ensure that any finds such as relic, antiquity, coins, fossils, etc. which he may come across during the course of performance of his Works either during excavation or elsewhere, are properly protected and handed over to the Employer. Similarly the Contractor shall ensure that the bench marks, reference points, etc., which are marked either with the help of Employer or by the Employer shall not be disturbed in any way during the performance of his Works. If, any work is to be performed which disturb such reference, the same shall be done only after these are transferred to other suitable locations under the direction of the Employer. The Contractor shall provide all necessary materials and assistance for such relocation of reference points etc.

#### **25.18 Emergency Action Plan.**

The contractor shall prepare an emergency action plan approved by his competent authority to handle any emergency occurred during construction work. Regular mock drills shall be organized to practice this emergency plan. The Emergency Action Plan should be widely circulated to all the employees and suitable infrastructure shall be provided to handle the emergencies.

#### **25.19 Explosives.**

The contractor shall take all precautions while handling, using, storing or transporting of all explosives. Before usage of any explosive necessary warning /danger signals be erected at conspicuous places to warn the workers and general public. The contractor should strictly ensure that all measures and precautions required to be complied for use, handling, storing or transportation of explosives under the rules framed under the Explosives Act, 1884.

#### **25.20 Cofferdam and Caissons (if required)**

The Contractor shall ensure that the cofferdam and caissons are of good construction and adequate strength. The cofferdam and caissons should be provided with adequate means for workers to reach safely at the top of such dams in the event of an in-rush of water. The workers should be allowed to work in a cofferdam or caisson only after inspection and found safe by Engineer-in –charge. Such inspection is to be maintained in a Register. Where the workers are employed to work in a compressed air environment at the work site of coffer dam or caissons a Construction Medical Officer assisted by a Nurse or trained first aid attendant should be available at all the times during such work.

#### **25.21 Fencing of Machinery.**

The contractor shall provide suitable fencing or guard to all dangerous and moving parts of machinery. The contractor shall not allow any of the employees to clean, lubricate, repair, adjust or examine during machinery in motion, which may cause injury to the person. Working Platforms should be fenced and shall have means of access

#### **25.22 Carrying of Excessive Weight by a Worker.**

The worker shall not be allowed to lift by hand or carry over his head, back or shoulder more than the maximum limit set by the prescribed rules for the construction Workers.

NIT Issued By

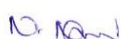

Mowleeswaran Natesan,  
Dy. Manager-Civil, BHEL-EDN

CONTACTOR (SIGN & SEAL)

### **25.23 Dangerous and Harmful Gases/Equipment.**

The contractor shall ensure that the workers are not exposed to any harmful gases during any construction activity including excavation, tunnelling, confined spaces etc. The contractor should not allow any worker to go into the confined space unless it is certified by Engineer in-charge to be safe and fit for the entry to such work place. Proper record and work permits should be followed to carry out such works.

### **25.24 Overhead Protection.**

The contractor shall ensure that any area exposed to risk of falling materials, articles or objects is roped off or cordoned off or otherwise suitably guarded from inadvertent entry of any person. Wherever there is a possibility of falling of any material, equipment or construction workers while working at heights, a suitable and adequate safety net should be provided. The safety net should be in accordance with BIS Standards.

### **25.25 Working at Heights (If applicable).**

a) All working platforms, ways and other places of construction work shall be free from accumulations of debris or any other material causing obstructions and tripping.

b) Wherever workers are exposed to the hazard of falling into water, the contractor shall provide adequate equipment for saving the employees from drowning and rescuing from such hazards. The contractor shall provide boat or launch equipped with sufficient number of life buoys, life jackets etc. manned with trained personnel at the site of such work.

c) Every opening at elevation from ground level through which a building worker, vehicle, material equipment etc. may fall at a construction work shall be covered and/or guarded suitably by the contractor to prevent such falls.

d) Wherever the workers are exposed to the hazards of falling from height, the contractor shall provide full harness safety belts fitted with fall arresting systems to all the employees working at higher elevations and life line of 8mm diameter wire rope with turn buckles for anchoring the safety belts while working or moving at higher elevations. Safety nets shall also be provided for saving them from fall from heights and such equipment should be in accordance with BIS standards.

e) Wherever there is a possibility of falling of any material, equipment or construction workers while working at heights, a suitable and adequate safety net should be provided. The safety net should be in accordance with BIS Standards.

f) The contractor shall provide standard prefabricated ladders on the columns where the workers are required to use them as an access for higher elevations till permanent staircase is provided. The workers shall be provided with safety belts fitted with suitable fall arresting system (fall arresters) for climbing/getting down through ladders to prevent fall from height.

g) Rungs shall not be welded on columns. All the Stairs shall be provided with handrails immediately after its erection.

### **25.26 Handling of Hazardous Chemicals.**

a) The Contractor will notify well in advance to the Engineer-in-charge of his intention to bring to the Site any container filled with liquid or gaseous fuel or explosive or petroleum

NIT Issued By

CONTACTOR (SIGN & SEAL)



Mowleeswaran Natesan,  
Dy. Manager-Civil, BHEL-EDN

substance or such chemicals which may involve hazards. SCCL /BHEL shall have the right to prescribe the conditions, under which such container is to be stored, handled and used during the performance of the works and the Contract shall strictly adhere to and comply with such instructions. The Engineer-in-charge shall have the right at his sole discretion to inspect any such container or such construction plant / equipment for which material in the container is required to be used

And if in his opinion, its use is not safe; he may forbid its use. No claim due to such prohibition shall be entertained by SCCL and SCCL shall not entertain any claim of the Contractor towards additional safety provisions /conditions to be provided for / constructed.

b) Further, any such decision of the Engineer-in-charge shall not, in any way, absolve the Contractor of his responsibilities and in case, use of such a container or entry thereof into the Site area is forbidden by SCCL/BHEL, the Contractor shall use alternative methods with the approval of the SCCL /BHEL without any cost implication to the SCCL /BHEL or extension of work schedule.

c) Where it is necessary to provide and / or store petroleum products or petroleum mixtures and explosives, the Contractor shall be responsible for carrying-out such provision and / or storage in accordance with the rules and regulations laid down in Petroleum Act 1934, Explosives Act 1948, and Petroleum and Carbide of Calcium Manual published by the Chief Inspector of Explosives of India. All such storage shall have prior approval of the Engineer In-charge In case any approvals are necessary from the Chief Inspector (Explosives) or any statutory authorities; the Contractor shall be responsible for obtaining the same.

d) The Contractor shall be fully responsible for the safe storage of his and his Sub-contractor's radio-active sources in accordance with BARC/DAE (Bhabha Atomic Research Centre/ Department of Atomic Energy, Govt. of India) Rules and other applicable provisions- AU precautionary measures stipulated by BARC/DAE in connection with use, the contractor would take  
Storage and handling of such material.

e) The contractor shall provide suitable personal protective equipment's to the workers who are handling the hazardous and corrosive substances including alkalis and acids.

f) As a precautionary measure the contractor should keep the bottles filled with distilled water in cupboard / Boxes near work place for emergency eyewash by worker exposed to such hazardous chemicals.

### **25.27 Eye Protection.**

The contractor shall provide suitable personal protective equipment to his workmen depending upon the nature of hazards and ensure their usage by the workers engaged in operations like welding, cutting, chipping, grinding or similar operations which may cause injuries to his eyes.

NIT Issued By



Mowleeswaran Natesan,  
Dy. Manager-Civil, BHEL-EDN

CONTACTOR (SIGN & SEAL)

### **25.28 Excavation.**

The contractor shall take all necessary measures during excavation to prevent the hazards of falling or sliding material or article from any bank or side of such excavation which is more than one and a half meter above his footing by providing adequate piling, shoring, bracing etc. against such bank or sides. Adequate and suitable warning signs shall be put up at conspicuous places at the excavation work to prevent any persons or vehicles falling into the excavation trench. No worker should be allowed to work where he may be stuck or endangered by excavation machinery or collapse of excavations or trenches.

### **25.29 Electrical Hazards.**

a) The contractor should ensure that all electrical installations at the construction work comply with the requirements of latest electricity acts /rules.

b) The contractor shall take all adequate measures to prevent any worker from coming into physical contact with any electrical equipment or apparatus, machines or live electrical circuits which may cause electrical hazards during the construction work. The contractor shall provide the sufficient ELCBs / RCCBs for all the portable equipment's, electrical switchboards, distribution panels etc. to prevent electrical shocks.

c) The contractor should ensure use of single / double insulated hand tools or low voltage i.e., 110 volts hand tools.

d) The contractor should also ensure that all temporary electrical installations at the construction works are provided with earth leakage circuit breakers.

e) No electric cable in use by the Contractor /Employer will be disturbed without prior permission. No weight of any description will be imposed on any cable and no ladder or similar equipment will rest against or attached to it.

f) The Contractor shall employ necessary number of qualified, full time Electricians/electrical supervisors to maintain his temporary electrical installations.

### **25.30 Vehicular Traffic.**

The contractor should employ vehicle drivers who hold a valid driving license under the Motor Vehicles Act, 1988.

### **25.31 Lifting Appliances, Tools & Tackles. Lifting Gear and Pressure Plant & Equipment etc.**

The contractor shall ensure all the lifting appliances, tools & tackles including cranes etc., lifting gear including fixed or movable and any plant or gear, hoists, Pressure Plant and equipment etc. are in good condition and shall be examined by competent person and only certified shall be used at sites. Periodical Examination and the tests for all lifting / hoisting equipment & tackles shall be

Carried out. A register of such examinations and tests shall be properly maintained by the Contractor and will be promptly produced as and when desired by the Engineer I/c or by the person authorized by him.

NIT Issued By



Mowleeswaran Natesan,  
Dy. Manager-Civil, BHEL-EDN

CONTACTOR (SIGN & SEAL)

### **25.32 Excessive Noise, Vibration.**

The contractor shall take adequate measures to protect the workers against the harmful effect of excessive noise or vibration. The noise should not exceed the limits prescribed under the concerned rules. Noise Pollution (Regulation and Control) Rules, 2000.

### **25.33 Electrical Installations.**

a) The Contractor shall not interfere or disturb electric fuses, wiring and other electrical equipment ongoing to the Employer or other contractors under any circumstances, whatsoever, unless expressly permitted in writing by the Engineer I/c to handle such fuses, wiring or electrical equipment. Before the

b) Contractor connects any electrical appliances to any plug or socket SCCL ongoing to the other contractor or the SCCL /BHEL, he shall :-Satisfy the Engineer I/C that the appliance is in good working condition; Inform the Engineer I/C of the maximum current rating, voltage and phases of the appliances; Obtain permission of the Engineer-in-Charge detailing the sockets to which the appliances may be connected.

c) The Engineer in-charge will not grant permission to connect until he is satisfied that :- The appliance is in good condition and is fitted with suitable plug; having earth connection with the body. Wherever armoured / metallic sheathed multi core cable is used, the same armoured / sheathed should be connected to earth.

d) No repair work shall be carried out on any live equipment. The Engineer in-Charge must declare the equipment safe and a permit to work shall be issued by the SCCL /BHEL / contractor as the case may be to carry out any repair/ maintenance work. While working on electric lines / equipment's whether live or dead, suitable type and sufficient quantity of tools will have to be provided by the contractor to electricians / workmen / Officers.

e) The contractor shall employ necessary number of qualified, full time Electricians / Electrical Supervisors to maintain his temporary electrical installation.

f) The installations are provided with suitable ELCBs and RCCBs wherever required.

### **25.34 Safety Organisation.**

a) The contractor employing more than 250 workmen whether temporary, casual, probationary, regular or permanent shall employ at least one fulltime safety officer exclusively to supervise safety aspects of the equipments and workmen, who will coordinate with the SCCL /BHEL Safety Officer. Further requirement of safety officers, if any, shall be guided by Rule 209 of The Building and Other Construction Worker (Regulation of Employment and Conditions of Service) Central Rule 1998. In case the work is being carried out through subcontractor, the employees / workmen of the sub-contractor shall also be considered as the contractor's employees/workmen for the above purpose.

b) In case of contractor deploying less than 250 workmen he should designate one of his Engineer / supervisor or the contractor himself (if he is directly supervising the work) as

NIT Issued By



Mowleeswaran Natesan,  
Dy. Manager-Civil, BHEL-EDN

CONTACTOR (SIGN & SEAL)

safety officer in addition to his existing responsibilities. The Engineer/ supervisor should get at least 2 days safety training from any reputed organization or from SCCL/BHEL before resuming the work. If already trained in past the declaration along with training. Certificate to be furnished to SCCL safety officer.

c) The name and address of such Safety Officer of the Contractor will be promptly informed in writing to the EIC with a copy to the Project Safety Officer before he starts work or immediately after any change of the incumbent is made during currency of the Contract.

### **25.35 Reporting of Accident and Investigation.**

In case any accident occurs during the construction / erection or other associated activities undertaken by the Contractor thereby causing any near miss, minor or major or fatal injury to his employees due to any reason, whatsoever, it shall be the responsibility of the Contractor to promptly inform the same to the Engineer in charge, SCCL /BHEL Safety Officer with a copy to SCCL /BHEL Head of Project in the prescribed form and also to all the authorities envisaged under the applicable laws.

### **26. Right to stop Work.**

a) The Engineer I/C shall have the right at his sole discretion to stop the work, if in his opinion the work is being carried out in such a way that it may cause accidents and endanger the safety of the persons and / or property, and / or equipment's. In such cases, the contractor shall be informed in

Writing about the nature of hazards and possible injury / accident and he shall comply to remove shortcomings promptly. The Contractor after stopping the specific work can, if felt necessary appeal against the order of stoppage of work to the Project Manager within 3 days of such stoppage of work and decision of the Project Manager in this respect shall be conclusive and binding on the Contractor.

b) The Contractor shall not be entitled for any damages / compensation for stoppage of work due to safety reasons and the period of such stoppage of work shall not be taken as an extension of time for Completion of the Facilities and will not be the ground for waiver of levy of liquidated Damages.

### **27. Fire Protection.**

a) The contractor shall provide sufficient fire extinguishers at place /s of work. The fire extinguishers shall be properly maintained as per relevant BIS Standards. The employees shall be trained to operate the fire extinguishers / equipment.

b) The Contractor shall provide enough fire protection equipment of the types and number for the warehouses, office, temporary structures, labour colony area etc. Access to such fire protection equipment, shall be easy and kept open at all time.

c) The work procedures that are to be used during the erection shall be those which minimise fire hazards to the extent practicable. Combustible materials, combustible waste and rubbish shall be collected and removed from the Site at least once each day. Fuels, oils and volatile or flammable

NIT Issued By



Mowleeswaran Natesan,  
Dy. Manager-Civil, BHEL-EDN

CONTACTOR (SIGN & SEAL)

Materials shall be stored away from the construction and equipment and materials storage areas in safe containers. Untreated canvas, paper, plastic or other flammable flexible materials shall not at all be used at Site for any other purpose unless otherwise specified. If any such materials are

Received with the equipment at the Site, the same shall be removed and replaced with acceptable material before moving into the construction or storage area.

d) Similarly corrugated paper fabricated cartons etc. will not be permitted in the construction area either for storage or for handling of materials. All such materials used shall be of water proof and flame resistant type. All the other materials such as working drawings, plans etc. which are combustible but are essential for the works to be executed shall be protected against combustion resulting from welding sparks, cutting flames and other similar fire sources.

e) All the Contractor's supervisory personnel and sufficient number of workers shall be trained for fire-fighting and shall be assigned specific fire protection duties. Enough of such trained personnel must be available at the Site during the entire period of the Contract.

## **28. Penalties.**

a) If the Contractor fails in providing safe working environment as per the Safety Rules of SCCL /BHEL or continues the work even after being instructed to stop the work by the Engineer –in- Charge as provided above, the Contractor shall be penalized at the rate of Rs. 25,000/-- per day or part thereof till the instructions are complied with and so certified by the Engineer I/C- However, in case of accident, the provisions contained below shall also apply in addition to the penalties mentioned in this sub clause.

b) If the Contractor does not take all safety precautions and / or fails to comply with the Safety Rules as prescribed by the Employer or under the applicable law for the safety of the plant and equipment and for the safety of personnel and the contractor does not prevent hazardous conditions which cause injury to this own employees or employees of other contractors, or SCCL 's employees or any other person who are at the Site or adjacent thereto, the Contractor shall be responsible for payment of penalty to SCCL as per the following schedule; -

a) Fatal injury or accident causing death: Penalty @10% of contract value death or Rs. 5,00,000/- per person, whichever is less.

b) Major injuries or accident causing 25% or more permanent disablement to workmen or employees. Penalty @2.5 % of contract value or Rs.1,00,000/- per person, whichever is less.

Permanent disablement shall have the same meaning as indicated in The Workmen's Compensation Act' 1923. The penalty mentioned above shall be in addition to the compensation payable to the workmen / employees under the relevant provisions of the Workmen's Compensation Act' 1923and rules framed there under or any other applicable laws as applicable from time to time.

c) If any contractor worker found working without using the safety equipment like safety helmet, safety shoes, safety belts, etc. or without anchoring the safety belts while working

NIT Issued By

CONTACTOR (SIGN & SEAL)



Mowleeswaran Natesan,  
Dy. Manager-Civil, BHEL-EDN

at height the Engineer in-charge / Safety Officer of SCCL shall have the right to penalize the contractor for Rs. 200/- per person per day and such worker shall be sent out of the workplace immediately and shall not be allowed to work on that day. Engineer in charge/ Safety Officer of SCCL will also issue a notice in this regard to the contractor.

d) If two or more fatal accidents occur at same SCCL site under the control of contractor during the period of contract and he has:-

- (1) Not complied with keeping adequate PPEs in stock,
- (2) Defaulted in providing PPR's to his workmen
- (3) Not followed statutory requirements / SCCL safety rules
- (4) Been issued warning notice/s by SCCL head of the project on non Observance of safety norms

(5) Not provided safety training to all his workmen, the contractor can Be debarred from getting tender documents in SCCL for two years from the date of last accident.

e) The safety performance will also be one of the overriding criteria for evaluation of overall performance of the contractors by SCCL. The contractor shall submit the accident data including fatal / non-fatal accidents for the last 3 years where he has undertaken the construction activities Projects-wise along with the tender documents. This will also be considered for evolution of tender documents. If the information given by the contractor found incorrect, his contract will be liable to be terminated.

Royalty certificates to be supplied by the contractor.

#### **29. Submission of Royalty certificate/MTC MANDATORY**

NIT Issued By



Mowleeswaran Natesan,  
Dy. Manager-Civil, BHEL-EDN

CONTACTOR (SIGN & SEAL)



# GENERAL CONDITIONS OF CONTRACT

2019

*ಭಾರತ್ ಹೆವಿ ಎಲೆಕ್ಟ್ರಿಕಲ್ಸ್ ಲಿಮಿಟೆಡ್, ವಿದ್ಯುನ್ಮಾನ ವಿಭಾಗ, ಬೆಂಗಳೂರು  
भारत हेवी इलेक्ट्रिकल्स लिमिटेड, इलेक्ट्रॉनिक्स डिवीज़न, बेंगलुरु  
Bharat Heavy Electricals Limited, Electronics Division, Bengaluru*

## **CONTENTS**

### **Chapter-1**

#### *1. General Instructions to Tenderers*

##### *1.1. Dispatch Instructions*

##### *1.2. Submission of Tenders*

##### *1.3. Language*

##### *1.4. Price Discrepancy*

##### *1.5. Evaluation of Bids*

##### *1.6. Data to be enclosed*

##### *1.7. Authorisation and Attestation*

##### *1.8. Earnest Money Deposit*

##### *1.9. Security Deposit*

##### *1.10. Return of Security Deposit*

##### *1.11. Bank Guarantee*

##### *1.12. Validity of offer*

##### *1.13. Execution of Contract Agreement*

##### *1.14. Rejection of Tender and other Conditions*

##### *1.15 BHEL Fraud Prevention Policy*

## **2. Chapter-2**

*2.1. Definitions*

*2.2. Law Governing Contract and Court Jurisdiction*

*2.3. Issue of Notice*

*2.4. Use of land*

*2.5. Commencement of Work*

*2.6. Measurement of Work and Mode of Payment*

*2.7. Rights of BHEL*

*2.8. Responsibilities of Contractor in respect of Local Laws, Employment of Workers etc*

*2.9. Progress Monitoring, Monthly Review and Performance Evaluation*

*2.10. Time of Completion*

*2.11. Extension of Time for Completion*

*2.12. Over Run Compensation*

*2.13. Quantity Variation*

*2.14. Extra Works*

*2.15. Supplementary Items*

*2.16. Strikes & Lockout*

*2.17. Force Majeure*

*2.18. Arbitration and Reconciliation*

*2.19. Payments*

*2.20. Performance Guarantee for Workmanship*

*2.21. Closing of Contracts*

*2.22. Reverse Auction*

*2.23. Suspension of Business Dealings*

*2.24. Other Issues*

## **CHAPTER -1**

### **1. GENERAL INSTRUCTION TO TENDERERS**

#### **1.1. DESPATCH INSTRUCTION**

*i) The General Conditions of Contract form part of the Tender specifications. All pages of the tender documents shall be duly signed, stamped and submitted along with the offer in token of complete acceptance thereof. The information furnished shall be complete by itself. The tenderer is required to furnish all the details and other documents as required in the following pages*

*ii) Tenderers are advised to study all the tender documents carefully. Any submission of tender by the tenderer shall be deemed to have been done after careful study and examination of the tender documents and with the full understanding of the implications thereof. Should the tenderers have any doubt about the meaning of any portion of the Tender Specification or find discrepancies or omissions in the drawings or the tender documents issued are incomplete or shall require clarification on any aspects, the scope of work etc., he shall contact the authority inviting the tender well in time (so as not to affect last date of submission) for clarification before the submission of the tender. Tenderer's request for clarifications shall be with reference to Sections and Clause numbers given in the tender documents. The tender specifications and terms and conditions shall be deemed to have been accepted by the tenderer in the offer. Pre requirements and conditions shall be liable for rejection.*

*iii) Integrity pact (IP): If NIT calls for Integrity Pact, the same shall be duly signed & stamped by the authorised signatory & submitted along with tender document.*

#### **1.2. SUBMISSION OF TENDERS**

*1.2.1 The tenderers must submit their tenders as per instructions in the NIT*

*1.2.2 BHEL takes no responsibility for delay, loss or non-receipt of tenders sent by post/courier. The tenders received after the specified time of their submission are treated as 'Late Tenders' and shall not be considered under any circumstances. Offers received by Fax/Email/Internet shall be considered as per terms of NIT.*

*1.2.3 Tenders shall be opened by authorised Officer of BHEL at his office at the time and date as specified in the NIT, in the presence of such of those tenderers or their authorised representatives who may be present*

*1.2.4 Tenderers whose bids are found techno commercially qualified shall be informed the date and time of opening of the Price Bids and such Tenderers may depute their representatives to witness the opening of the price bids. BHEL's decision in this regard shall be final and binding.*

*1.2.5 Before submission of Offer, the tenderers are advised to inspect the site of work and the environments and be well acquainted with the actual working and other prevalent conditions, facilities available, position of material and labour, means of transport and access to Site, accommodation, etc. No claim will be entertained later on the grounds of lack of knowledge of any of these conditions.*

### **1.3. LANGUAGE**

*1.3.1 The tenderer shall quote the rates in English language and international numerals. These rates shall be entered in figures as well as in words. For the purpose of the tenders, the metric system of units shall be used.*

*1.3.2 All entries in the tender shall either be typed or written legibly in ink. Erasing and over-writing is not permitted and may render such tenders liable for rejection. All cancellations and insertions shall be duly attested by the tenderer.*

### **1.4 PRICE DISCREPANCY:**

#### **1.4.1 Conventional (Manual) Price Bid opening:**

*i) If, in the price structure quoted for the required goods/services/works, there is discrepancy between the unit price and the total price (which is obtained by multiplying the unit price by the quantity), the unit price shall prevail and the total price corrected accordingly, unless in the opinion of BHEL there is obvious misplacement of decimal point in the unit price, in which case the total price as quoted shall govern and the unit price corrected accordingly*

*ii) If there is an error in a total corresponding to the addition or subtraction of subtotals, the subtotals shall prevail and the total shall be corrected;*

*iii) If there is a discrepancy between words and figures, the amount in words shall prevail, unless the amount expressed in words is related to an arithmetic error, in which case the amount in figures shall prevail subject of (i) and (ii) above.*

*iv) If there is such discrepancy in an offer, the same shall be conveyed to the bidder with target date up to which the bidder has to send his acceptance on the above lines and if the bidder does not agree to the decision of BHEL, the bid is liable to be ignored.*

*v) In case of lump sum price, if there is any difference between the amount in figures and in words, the amount quoted by the bidder in words shall be taken as correct.*

vi) *In case of omission in quoting any rate for one or more items, the evaluation shall be done considering the highest quoted rate obtained against the respective items by other tenderers for the subject tender. If the tenderer becomes L-1, the notional rates for the omission items shall be the lowest rates quoted for the respective items by the other tenderers against the respective omission items for the subject job and the 'Total quoted price (loaded for omissions)' shall be arrived at. However the overall price remaining the same as quoted originally, the rates for all the items in the 'Total quoted price (loaded for omissions)' shall be reduced item wise in proportion to the ratio of 'Original' total price and the 'Total quoted price (loaded for omissions)'.*

**1.4.2 Reverse Auction:** *In case of Reverse Auction, the successful bidder shall undertake to execute the work as per overall price offered by him during the Reverse Auction process. In case of omission of rates, the procedure shall be as per 'Guidelines for Reverse Auction' enclosed.*

i) *Offers from tenderers who are under suspension (banned) by any Unit/Region/Division of BHEL shall not be considered.*

ii) *Offers from tenderers who do not comply with the latest guidelines of Ministry/Commissions of Govt of India shall not be considered.*

### **1.5. EVALUATION OF BIDS**

i) *Technical Bids submitted by the tenderer will be opened first and evaluated for fulfilling the Pre-Qualification criteria and other conditions in NIT/Tender documents, based on documentary evidences submitted along with the offer, BHEL reserves the right to ask for proofs/documents, clarification in relation to Technical/commercial data during tender evaluation*

ii) *Price Bids of shortlisted bidders shall only be opened either through the conventional price bid opening or through electronic Reverse Auction, at the discretion of BHEL*

iii) *Price Bids of unqualified bidders shall not be opened. Reasons for rejection shall be intimated to the vendor before the opening of Price bid.*

### **1.6. DATA TO BE ENCLOSED**

*The following information in full shall be furnished by the tenderer. Non-submission of this information may lead to rejection of the offer.*

i) *INCOME TAX PERMANENT ACCOUNT NUMBER, GSTIN, SAC, HSN Certified copies of PAN, GSTIN shall be furnished along with tender. The names, addresses and contact information of the Directors/Partners shall be furnished along with the offer.*

ii) *An attested copy of the Power of Attorney, in case the tender is signed by an individual other than the sole proprietor.*

*iii) IN CASE OF INDIVIDUAL TENDERER:*

*His / her full name, address, PAN, GSTIN and place & nature of business to be furnished.*

*iv) IN CASE OF PARTNERSHIP FIRM*

*The names of all the partners and their addresses, a copy of the partnership deed/instrument of partnership shall be enclosed.*

*v) IN CASE OF COMPANIES:*

*Date and place of registration including date of commencement certificate in case of Public Companies (certified copies of Memorandum and articles of Association are also to be furnished). Nature of business carried on by the Company and the provisions of the Memorandum relating thereof.*

**1.7. AUTHORISATION AND ATTESTATION**

*Tenders shall be signed by a person duly authorised/empowered to do so. An attested copy of the Power of Attorney, in case the tender is signed by an individual other than the sole proprietor shall be submitted along with the tenders*

**1.8. EARNEST MONEY DEPOSIT**

*1.8.1 Every tender must be accompanied by the prescribed amount of Earnest Money Deposit (EMD) in the manner described herein.*

*The EMD may be accepted only in the following forms:*

- (i) Electronic Fund Transfer credited in BHEL account (before tender opening)*
- (ii) Banker's cheque/ Pay order/ Demand draft, in favor of BHEL (along with offer) In case total EMD amount is more than Rs 20 Lakh, the amount in excess of Rs 20 lakh maybe accepted in the form of Bank Guarantee from scheduled bank. The Bank Guarantee in such cases shall be valid for at-least six months.*
- (iii) Through SBI collect (before tender opening)*
- (iv) No other form of EMD remittance shall be acceptable to BHEL*

*1.8.2 EMD by the bidder will be forfeited as per Tender Documents if*

- i) After opening the tender and within the offer validity period, the tenderer revokes his/her tender or makes any modification in his tender which is not acceptable to BHEL.*
- ii) The Contractor fails to deposit the required Security deposit or commence the work within the period as per LOI/ Contract.*
- iii) EMD by the tenderer shall be withheld in case any action on the tenderer is envisaged in derailing the tender process by unlawful means*

*1.8.3 EMD shall not carry any interest.*

*1.8.4 In the case of unsuccessful bidders, the Earnest Money will be refunded to them within a reasonable time after acceptance of award by successful tenderer.*

*1.8.5 EMD of successful tenderer will be converted as part of Security Deposit*

### **1.9. SECURITY DEPOSIT**

*The total amount of Security Deposit will be 5% of the contract value (including all applicable taxes) EMD of the successful tenderer shall be converted and adjusted towards the required amount of Security Deposit.*

#### **1.9.1 Modes of Security deposit:**

*The balance amount to make up the required Security Deposit of 5% of the contract value may be accepted in the following forms:*

- i) Cash (as permissible under the extant Income Tax Act)*
- ii) Local cheques of Scheduled Banks (subject to realization)/ Pay Order/ Demand Draft/ Electronic Fund Transfer in favour of BHEL*
- iii) Bank Guarantee from Scheduled Banks/ Public Financial Institutions as defined in the Companies Act. The Bank Guarantee format should have the approval of BHEL*
- iv) Fixed Deposit Receipt issued by Scheduled Banks/ Public Financial Institutions as defined in the Companies Act (FDR should be in the name of the Contractor, a/c BHEL)*
- v) Securities available from Indian Post offices such as National Savings Certificates, Kisan Vikas Patras etc. (held in the name of Contractor furnishing the security and duly endorsed/ hypothecated/ pledged, as applicable, in favour of BHEL) (Note: BHEL will not be liable or responsible in any manner for the collection of interest or renewal of the documents or in any other matter connected therewith)*
- vi) 50% of the required Security Deposit, including the EMD, should be paid before start of the work. Balance of the Security Deposit can be collected by deducting 10% of the gross amount progressively from each of the running bills of the Contractor till the total amount of the required Security Deposit is collected. If the value of work done at any time exceeds the contract value, the amount of Security Deposit shall be correspondingly enhanced and the additional Security Deposit shall be immediately deposited by the Contractor or recovered from payment/s due to the Contractor. Security Deposit shall be released to the Contractor upon fulfilment of contractual obligations as per terms of the contract.*

*1.9.2 The Security Deposit shall not carry any interest.*

*1.9.3 The validity of Bank Guarantees towards Security Deposit shall be initially up to the completion period as stipulated in the Letter of Intent/Award ( plus maintenance period if applicable), and 03 months claim period. The same shall be kept valid by proper renewal till the acceptance of Final Bills of the Contractor, by BHEL*

*1.9.4 BHEL reserves the right of forfeiture of Security Deposit in addition to other claims and penalties in the event of the Contractor's failure to fulfill any of the contractual obligations or in the event of termination of contract as per terms and conditions of contract. BHEL reserves the right to set off the Security Deposit against any claims of other contracts with BHEL.*

### **1.10. REFUND OF SECURITY DEPOSIT**

*50% of the security deposit may be refunded on completion of the work after payment of the final bill and the balance 50% of the security deposit is refunded only after the expiry of the maintenance period from date of completion of work as stipulated in the contract concerned.*

#### **1.10.1 DEFECTS LIABILITY PERIOD:**

*The contractor shall be responsible to make good and remedy at his own expenses within such period as may be stipulated by the Engineer-in-charge, any defect which may develop or may be noticed before the expiry of the maintenance period of six months or as stipulated in NIT hereto from the certified date of completion and intimation of which has been sent to the contractor within seven days of the expiry of the said period by a letter sent by hand delivery or by registered post or Email. If contractor fails to attend to the above, defect will be rectified at contractor's risk & cost and same will be deducted from the security deposit/payable amounts available with BHEL.*

### **1.11. BANK GUARANTEES**

*Where ever Bank Guarantees are to be furnished/submitted by the contractor, the following shall be complied with*

*i) Bank Guarantees shall be from Scheduled Banks / Public Financial Institutions as defined in the Companies Act.*

*ii) The Bank Guarantees shall be as per prescribed BHEL formats.*

*iii) It is the responsibility of the bidder to get the Bank Guarantees revalidated/extended for the required period (subject to a minimum period of six months), as per the advice of BHEL. BHEL shall not be liable for issue of any reminders regarding expiry of the Bank Guarantees.*

*iv) In case extension/further extensions of any Bank Guarantees are not required, the bidders shall ensure that the same is explicitly endorsed by BHEL*

*v) In case the Bank Guarantees are not extended before the expiry date, BHEL reserves the right to invoke the same by informing the concerned Bank in writing, without any advance notice/communication to the concerned bidder.*

*vi) Bidders to note that any corrections to Bank Guarantees shall be done by the issuing Bank, only through an amendment in an appropriate non judicial stamp paper.*

*vii) The Original Bank Guarantee shall be sent directly by the Bank to BHEL under Registered Post (Acknowledgement Due).*

### **1.12. VALIDITY OF OFFER**

*The rates in the Tender shall be kept open for acceptance for a minimum period of Ninety (90) DAYS from latest due date of offer submission (including extension, if any). In case BHEL calls for negotiations, such negotiations shall not amount to cancellation or withdrawal of the original offer which shall be binding on the tenderers.*

### **1.13 EXECUTION OF CONTRACT AGREEMENT**

*The successful tenderer's responsibility under this contract commences from the date of issue of the Letter of Intent by BHEL. The Tenderer shall submit an unqualified acceptance to the Letter of Intent/Award within the period stipulated therein.*

*The successful tenderer shall be required to execute an agreement in the prescribed form, with BHEL, within fifteen days (15 days) after the acceptance of the Letter of Intent/Award, and in any case before releasing the first running bill. The contract agreement shall be signed by a person duly authorized/empowered by the tenderer. The expenses for preparation of agreement document shall be borne by Tenderer.*

### **1.14. REJECTION OF TENDER AND OTHER CONDITIONS**

*1.14.1 The acceptance of tender will rest with BHEL which does not bind itself to accept the lowest tender or any tender and reserves to itself full rights for the following without assigning any reasons whatsoever:-*

- a. To reject any or all of the tenders.*
- b. To split up the work amongst two or more tenderers as per NIT*
- c. To award the work in part if specified in NIT*
- d. In case of either of the contingencies stated in (b) and (c) above, the time for completion as stipulated in the tender shall be applicable.*

*1.14.2 Conditional tenders, unsolicited tenders, tenders which are incomplete or not in the form specified or defective or have been materially altered or not in accordance with the tender conditions, specifications etc., are liable to be rejected.*

*1.14.3 Tenders are liable to be rejected in case of unsatisfactory performance of the tenderer with BHEL, or tenderer under suspension (hold/banning /delisted ) by any unit / region / division of BHEL or tenderers who do not comply with the latest guidelines of Ministry/Commissions of Govt of India. BHEL reserves the right to reject a bidder in case it is observed that they are overloaded and may not be in a position to execute this job. The decision of BHEL will be final in this regard.*

1.14.4 If a tenderer who is a proprietor expires after the submission of his tender or after the acceptance of his tender, BHEL may at their discretion, cancel such tender. If a partner of a firm expires after the submission of tender or after the acceptance of the tender, BHEL may then cancel such tender at their discretion, unless the firm retains its character.

1.14.5 BHEL will not be bound by any Power of Attorney granted by changes in the composition of the firm made subsequent to the execution of the contract. They may, however, recognize such power of Attorney and changes after obtaining proper legal advice, the cost of which will be chargeable to the contractor concerned.

1.14.6 If the tenderer deliberately gives wrong information in his tender, BHEL reserves the right to reject such tender at any stage or to cancel the contract if awarded and forfeit the Earnest Money/Security Deposit/any other money due.

1.14.7 Canvassing in any form in connection with the tenders submitted by the Tenderer shall make his offer liable to rejection.

1.14.8 In case the Proprietor, Partner or Director of the Company/Firm submitting the Tender, has any relative or relation employed in BHEL, the authority inviting the Tender shall be informed, along with the Offer. Failing to do so, BHEL may, at its sole discretion, reject the tender or cancel the contract and forfeit the Earnest Money/Security Deposit.

1.14.9 The successful tenderer should not sub-contract part or complete work detailed in the tender specification undertaken by him without written permission of BHEL's Construction Manager/Site Incharge. The tenderer is solely responsible to BHEL for the work awarded to him.

1.14.10 The Tender submitted by a techno commercially qualified tenderer shall become the property of BHEL who shall be under no obligation to return the same to the bidder. However unopened price bids and late tenders shall be returned to the bidders after finalization of contract.

1.14.11 Unsolicited discount received after the due date and time of Bid Submission shall not be considered for evaluation. However, if the party who has submitted the unsolicited discount/rebate becomes the L-I party, then the awarded price i.e contract value shall be worked out after considering the discount so offered.

1.14.12 BHEL shall not be liable for any expenses incurred by the bidder in the preparation of the tender irrespective of whether the tender is accepted or not.

### **1.15 BHEL Fraud Prevention Policy :**

*The bidder along with its associate/ collaborators/sub-contractors/ Sub-Vendors/ Consultants/service providers shall strictly adhere to BHEL Fraud Prevention Policy displayed on BHEL website <http://www.bhel.com> and shall immediately bring to the notice of BHEL Management about any fraud or suspected fraud as soon as it comes to their notice. Fraud prevention policy and list of Nodal officers shall be hosted on BHEL website, vendor portals of Units/Regions Internet.*

## **CHAPTER-2**

*2.1 DEFINITION: The following terms shall have the meaning hereby assigned to them except where the context otherwise requires*

- i) BHEL shall mean Bharat Heavy Electricals Limited, a company registered under Companies Act 1956, with its Registered Office at BHEL HOUSE, SIRI FORT, NEW DELHI – 110 049, or its Authorised Officers or its Site Engineers or other employees authorised to deal with any matters with which these persons are concerned on its behalf.*
- ii) “EXECUTIVE DIRECTOR” or ‘GROUP GENERAL MANAGER’ or “GENERAL MANAGER (Incharge)” or “GENERAL MANAGER” shall mean the Officer in Electronics Division, Mysore road, Bengaluru-560026*
- iii) “COMPETENT AUTHORITY” shall mean Executive Director or Group General Manager or General Manager (In-charge) or General Manager or BHEL Officers who are empowered to act on behalf of the Executive Director or General Manager (In-charge) or General Manager of BHEL.*
- iv) “ENGINEER” or “ENGINEER IN CHARGE” shall mean an Officer of BHEL as may be duly appointed and authorized by BHEL to act as “Engineer” on his behalf for the purpose of the Contract, to perform the duty set forth in this General Conditions of Contract and other Contract documents. The term also includes ‘CONSTRUCTION MANAGER’ or ‘SITE INCHARGE’ as well as Officers*
- v) “SITE” shall mean the places or place at which the plants/equipment are to be erected and services are to be performed as per the specification of this Tender.*
- vi) “CLIENT OF BHEL” or “CUSTOMER” shall mean the project authorities with whom BHEL has entered into a contract for supply of equipment or provision of services.*
- vii) “CONTRACTOR” shall mean the successful Bidder/Tenderer who is awarded the Contract and shall include the Contractor’s successors, heirs, executors, administrators and permitted assigns.*

viii) “CONTRACT” or “CONTRACT DOCUMENT” shall mean and include the Work Order, Contract Agreement, the accepted appendices of Rates, Schedules, Quantities if any, General Conditions of Contract, Special Conditions of Contract, Instructions to the Tenderers, Drawings, Technical Specifications, the Special Specifications if any, the Tender documents, subsequent amendments mutually agreed upon and the Letter of Intent/Acceptance issued by BHEL. Any conditions or terms stipulated by the contractor in the tender documents or subsequent letters shall not form part of the contract unless, specifically accepted in writing by BHEL in the Letter of Intent/Award and incorporated in the agreement.

ix) “GENERAL CONDITIONS OF CONTRACT” shall mean the ‘Instructions to Tenderers’ and ‘General Conditions of Contract’ pertaining to the work for which above tenders have been called for.

x) “TENDER SPECIFICATION” or “TENDER” or “TENDER DOCUMENTS” shall mean General Conditions, Common Conditions, Special Conditions, Price Bid, Rate Schedule, Technical Specifications, Appendices, Annexures, Corrigendum’s, Amendments, Forms, procedures, Site information, etc and drawings/documents pertaining to the work for which the tenderers are required to submit their offers. Individual specification number will be assigned to each Tender Specification.

xi) “LETTER OF INTENT” shall mean the intimation by a Post/Fax/email to the tenderer that the tender has been accepted in accordance with provisions contained in the letter. The responsibility of the contractor commences from the date of issue of this letter and all terms and conditions of the contract are applicable from this date.

xii) “COMPLETION TIME” shall mean the period by ‘date/month’ specified in the ‘Letter of Intent/Award’ or date mutually agreed upon for handing over of the intended scope of work, the erected equipment/plant which are found acceptable by the Engineer, being of required standard and conforming to the specifications of the Contract.

xiii) “PLANT” shall mean and connote the entire assembly of the plant and equipment’s covered by the contract.

xiv) “EQUIPMENT” shall mean equipment, machineries, materials, structural, electrical and other components of the plant covered by the contract.

xv) “TESTS” shall mean and include such test or tests to be carried out on the part of the contractor as are prescribed in the contract or considered necessary by BHEL, in order to ascertain the quality, workmanship, performance and efficiency of the contractor or part thereof.

xvi) “APPROVED”, “DIRECTED” or “INSTRUCTED” shall mean approved, directed or instructed by BHEL.

xvii) *“WORK or CONTRACT WORK” shall mean and include supply of all categories of labour, specified consumables, tools and tackles and Plants required for complete and satisfactory site transportation, handling, stacking, storing, erecting, testing and commissioning of the equipment’s to the entire satisfaction of BHEL.*

xviii) *“SINGULAR AND PLURALS ETC” words carrying singular number shall also include plural and vice versa, where the context so requires. Words imparting the masculine Gender shall be taken to include the feminine Gender and words imparting persons shall include any Company or Associations or Body of Individuals, whether incorporated or not.*

xix) *“HEADING” – The heading in these General Conditions are solely for the purpose of facilitating reference and shall not be deemed to be part thereof or be taken as instructions thereof or of the contract.*

xx) *“MONTH” shall mean calendar month unless otherwise specified in the Tender.*

xxi) *Day’ or ‘Days’ unless herein otherwise expressly defined shall mean calendar day or days of twenty four (24) hours each. A week shall mean continuous period of seven (7) days.*

xxii) *“COMMISSIONING” shall mean the synchronization testing and achieving functional operation of the Equipment with associated system after all initial adjustments, trials, cleaning, re-assembly required at site if any, have been completed and Equipment with associated system is ready for taking into service.*

xxiii) *“WRITING” shall include any manuscript type written or hand written or printed statement or electronically transmitted messages, under the signature or seal or transmittal of BHEL.*

xxiv) *“TEMPORARY WORK” shall mean all temporary works for every kind required in or for the execution, completion, maintenance of the work.*

xxv) *‘CONTRACT PRICE’ or ‘CONTRACT VALUE’ shall mean the sum including applicable taxes mentioned in the LOI/LOA/Contract Agreement subject to such additions thereto or deductions there from as may be made under provisions hereinafter contained*

xxvi) *“COMMENCEMENT DATE” or “START DATE” shall mean the commencement/start of work at Site as per terms defined in the Tender*

xxvii) *“SHORT CLOSING” or “FORE CLOSING” of Contract shall mean the premature closing of Contract, for reasons not attributable to the contractor and mutually agreed between BHEL and the contractor*

xxviii) *“TERMINATION” of Contract shall mean the pre mature closing of contract due to reasons as mentioned in the contract*

## **2.2 LAW GOVERNING THE CONTRACT AND COURT JURISDICTION**

*The contract shall be governed by the Law for the time being in force in the Republic of India. The Civil Court having original Civil Jurisdiction at Bengaluru, shall alone have exclusive jurisdiction in regard to all claims in respect of the Contract. No other Civil Court shall have jurisdiction in case of any dispute, under this contract*

## **2.3 ISSUE OF NOTICE**

*2.3.1 Service of notice on contractor: Any notice to be given to the Contractor under the terms of the contract shall be served by sending the same by Registered Post / Speed Post / FAX / Email to or leaving the same at the Contractor's last known address of the principal place of business (or in the event of the contractor being a company, to or at its Registered Office). In case of change of address, the notice shall be served at changed address as notified in writing by the Contractor to BHEL. Such posting or leaving of the notice shall be deemed to be good service of such notice and the time mentioned to the condition for doing any act after notice shall be reckoned from the date so mentioned in such notice.*

*2.3.2 Service of notice on BHEL Any notice to be given to BHEL in-charge under the terms of the Contract shall be served by sending the same by post or Email or leaving the same at BHEL address or changed address as notified in writing by BHEL to the Contractor.*

## **2.4 USE OF LAND**

*No land belonging to BHEL or their Customer under temporary possession of BHEL shall be occupied by the contractor without written permission of BHEL.*

### **2.4.1 STORES AND MATERIALS:**

*The contractor shall, at his own expense, supply all stores and materials required for the contract, other than those which may be provided by BHEL at the rates detailed therein subject to their availability at the place of issue indicated therein. All stores and materials to be supplied by the Contractor shall be of the best kind as described in the Specifications and the Contractor shall, if required by the Engineer –in- charge furnish him with proof to his satisfaction that the store and materials so comply with the specifications.*

*The contractor shall, at his own expense and without delay, supply samples of stores and materials proposed to be used in the execution of the work for the approval of the Engineer-in charge, who may reject all stores and materials not corresponding either in quality or character to the approved samples.*

*In the case of stores provided by BHEL, the Contractor shall bear the cost of loading, transporting to site, unloading, storing under cover as required, assembling & jointing the several parts together as necessary and incorporating & fixing these stores & materials in the work, including all preparatory work of whatever description that may be required, and closing, preparing, loading and returning empty cases or containers to the place of issue without any extra charges.*

*Contractor is responsible for safe & secure storage of above material.*

**2.4.2 PATENT RIGHTS:**

*The contractor shall fully indemnify BHEL, or the agent, servant, or employee of BHEL, against any action, claim or proceeding relating to infringement or the use of any patent or design or any alleged patent or design rights, and shall pay any royalties which may be payable in respect of any article/ or part thereof included in the contract.*

*In the event of any claims being made or action brought against BHEL, or any agent, or servant or employee of BHEL., in respect of any of the matters aforesaid, the contractor shall not apply when such increment has taken place in complying with the specific directions issued by the BHEL but the contractor shall pay any royalties payable in respect of any such use.*

**2.4.3 WATER :**

*The contractor shall allow in his tender and provide at his cost all water required for the work or his employees on the work, together with all pipes and fittings or other means that may be necessary or required to ensure a proper and ample supply of water for all purpose connected with the work.*

*In the event of a provision existing in the Tender documents for supply of water on payment by BHEL, water will be supplied from the BHEL supply System, or other sources at any points fixed by the Site Engineer/ Engineer-in-charge on the site of work. The contractor shall make necessary arrangement for lifting, pumping, carrying or conveying the water as required at his own cost. The levy of water charges to be borne by the Contractor in such case shall be specifically mentioned in the Tender documents.*

**2.4.4 TEMPORARY WORKSHOPS, STORES ETC :**

*The Contractor shall, during the progress of the work provide, erect and maintain at his own expense all necessary temporary workshops, store, offices, toilets etc., required for the proper and efficient execution of the work. The planning, siting and erection of these building shall have the approval of the Engineer-in-charge and the Contractor shall at all times keep them in a clean and sanitized condition to the entire satisfaction of the Engineer-in-charge.*

*On completion of the work all such temporary buildings shall be cleared and the site restored to its original state in a clean and tidy condition to the entire satisfaction of the Engineer-in-charge.*

**2.5 COMMENCEMENT OF WORK**

*2.5.1 Time is essence of contract and is specified in the tender document or in each individual work order.*

*2.5.2 The contractor shall commence the work within seven(07) days from LOI/work order or as intimated by BHEL and shall proceed with the same with due expedition without delay.*

2.5.3 If the contractor fails to start the work within stipulated time as per LOI or as intimated by BHEL, then BHEL at its sole discretion will have the right to cancel the contract. The Earnest Money and/or Security Deposit with BHEL will stand forfeited without any further reference to him without prejudice to any and all of BHEL's other rights and remedies in this regard.

2.5.4 All the work shall be carried out under the direction and to the satisfaction of BHEL.

## **2.6 MEASUREMENT OF WORK AND MODE OF PAYMENT:**

2.6.1 All payments due to the contractors shall be made by electronic mode only, unless otherwise found operationally difficult.

2.6.2 For progress running bill payments: - The Contractor shall present detailed measurement sheets in triplicate, duly indicating all relevant details based on technical documents and connected drawings for work done during the month/period under various categories in line with terms of payment as per contract. The basis of arriving at the quantities, weights shall be relevant documents and drawings released by BHEL. These measurement sheets shall be prepared jointly with BHEL Engineers and signed by both the parties.

2.6.3 These measurement sheets will be checked by BHEL Engineer and quantities and percentage eligible for payment under various groups shall be decided by BHEL Engineer. The abstract of quantities and percentage so arrived at based on the terms of payment shall be entered in Measurement Book and signed by both the parties.

2.6.4 Based on the above quantities, contractor shall prepare the bills in prescribed format and work out the financial value. These will be entered in Measurement Book and signed by both the parties. Payment shall be made by BHEL after effecting the recoveries due from the contractor.

2.6.5 All recoveries due from the contractor for the month/period shall be effected in full from the corresponding running bills unless specific approval from the competent authorities is obtained to the contrary.

2.6.6 Measurement shall be restricted to that portion of work for which it is required to ascertain the financial liability of BHEL under this contract.

2.6.7 The measurement shall be taken jointly by persons duly authorized on the part of BHEL and by the Contractor.

2.6.8 The Contractor shall bear the expenditure involved if any, in making the measurements and testing of materials to be used/used in the work. The contractor shall, without extra charges, provide all the assistance with appliances and other things necessary for measurement.

2.6.9 If at any time due to any reason whatsoever, it becomes necessary to re-measure the work done in full or in part, the expenses towards such re measurements shall be borne by the contractor unless such re measurements are warranted solely for reasons not attributable to contractor.

2.6.10 Passing of bills covered by such measurements does not amount to acceptance of the completion of the work measured. Any left out work has to be completed, if pointed out at a later date by BHEL.

2.6.11 Final measurement bill shall be prepared in the final bill format prescribed for the purpose based on the certificate issued by BHEL Engineer that entire works as stipulated in tender specification has been completed in all respects to the entire satisfaction of BHEL. Contractor shall give unqualified "No Claim" Certificate. All the tools and tackles loaned to him should be returned in satisfactory condition to BHEL. The abstract of final quantities and financial values shall also be entered in the Measurement Books and signed by both parties to the contract. The Final Bill shall be prepared and paid within a reasonable time after completion of work.

## **2.7 RIGHTS OF BHEL**

BHEL reserves the following rights in respect of this contract during the original contract period or its extensions if any, as per the provisions of the contract, without entitling the contractor for any compensation.

2.7.1 To withdraw any portion of work and/or to restrict/alter quantum of work as indicated in the contract during the progress of work and get it done through other agencies to suit BHEL's commitment to its customer or in case BHEL decides to advance the date of completion due to other emergent reasons/ BHEL's obligation to its customer.

2.7.2 To terminate the contract or get any part of the work done through other agency or deploy BHEL's own/hired/otherwise arranged resources , at the risk and cost of the contractor after due notice of a period of two weeks by BHEL, in the event of:-

- i) Contractor's continued poor progress
- ii) Withdrawal from or abandonment of the work before completion of the work
- iii) Contractor's inability to progress the work for completion as stipulated in the contract
- iv) Poor quality of work
- v) Corrupt act of Contractor
- vi) Insolvency of the Contractor

vii) *Persistent disregard to the instructions of BHEL*

viii) *Assignment, transfer, sub-letting of contract without BHEL's written permission*

ix) *Non fulfillment of any contractual obligations / non-compliance of statutory requirements*

x) *In the opinion of BHEL, the contractor is overloaded and is not in a position to execute the job as per required schedule*

*2.7.3 To meet the expenses including BHEL overheads of 35% & Liquidated damage/penalties arising out of "Risk & Cost" as explained above under Sl.No. 2.7.2. BHEL shall recover the amount from any money due from Contractor, from any money due to the Contractor including Security Deposit or by forfeiting any T&P or material of the contractor under this contract or any other contract of BHEL or by any other means or any combination thereof*

*2.7.4 To terminate the contract or to restrict the quantum of work and pay for the portion of work executed in case BHEL's contract with their customer are terminated for any reason, as per mutual agreement.*

*2.7.5 To effect recovery from any amounts due to the contractor under this or any other contract or in any other form, the moneys BHEL is statutorily forced to pay to anybody, due to contractor's failure to fulfill any of his obligations. BHEL shall levy overheads of 35% on all such payments.*

*2.7.6 While every endeavor will be made by BHEL to this end, they cannot guarantee uninterrupted work due to conditions beyond their control. The Contractor will not be normally entitled for any compensation/extra payment on this account unless otherwise specified elsewhere in the contract.*

*2.7.7 In case the execution of works comes to a complete halt or reaches a stage wherein worthwhile works cannot be executed and there is no possibility of commencement of work for a period of not less than two months, due to reasons not attributable to the contractor and other than Force Majeure conditions, BHEL may consider permitting the contractor to demobilize forthwith and re mobilize at an agreed future date. Cost of such demobilization/remobilization shall be mutually agreed. ORC (Over run Charges) in such cases shall not be applicable for the period between the period of demobilization and re mobilisation. The duration of contract/time extension shall accordingly get modified suitably. In case of any conflict, BHEL decision in this regard shall be final and binding on the contractor.*

*2.7.8 In the unforeseen event of inordinate delay in receipt of materials, drawings, fronts, etc, due to which inordinate discontinuity of work is anticipated, BHEL at its discretion may consider contractor's request to short close the contract, provided that the balance works are minor vis a vis the scope of work envisaged as per the contract. At the point of requesting for*

*short closure, contractor shall establish that he has completed all works possible of completion and he is not able to proceed with the balance works due to constraints beyond his control. In such a case, the estimated value of the unexecuted portion of work as mutually agreed, shall however be reduced from the final contract value-*

#### **2.7.9 LIQUIDATED DAMAGES/PENALTY**

##### **COMPENSATION FOR DELAY:**

*If the contractor fails to maintain the required progress in terms of condition 2.10 or to complete the work and clear the site on or before the contracted or extended the period of completion, he shall, without prejudice to any other right or remedy of the BHEL on account of such breach, pay as agreed compensation an amount calculated as stipulated below*

*For unfinished anticipated value of work where finished portion is fit for use*

*Rate of compensation as follows:*

- *Completion period (as originally stipulated) not exceeding 6 months. ....@ 1 percent per week*
- *Completion period (as originally stipulated) Exceeding 6 months and not exceeding 2 years...@ 0.5 percent per week*
- *Completion period (as originally stipulated) exceeding 2 years..... @ 0.25 percent per week*

*Provided always that the total amount of compensation for delay to be paid under condition shall not exceed the under noted percentage of the anticipated contract value*

- *Completion period (as originally stipulated) not exceeding 6 months. ....@ 10 percent of anticipated value of work*
- *Completion period (as originally stipulated) Exceeding 6 months and not exceeding 2 years...@ 7.5 percent of anticipated value of work*
- *Completion period (as originally stipulated) Exceeding 2 years.....@ 5 percent of anticipated value of work*

*The amount of compensation may be adjusted or set off against any sum payable to the Contractor under this or any other contract with the BHEL.*

**2.7.10 POST TECHNICAL AUDIT OF WORK AND BILLS:** *BHEL reserve the right to carry out a post-payment audit and technical examination of the work and final bill including all supporting vouchers, abstract etc., and to enforce recovery of any sums becoming due as a result thereof in the manner provided in the proceeding sub-paragraph's provided however that no such recovery shall be enforced after three years of passing the final bill*

## **2.8 RESPONSIBILITIES OF THE CONTRACTOR IN RESPECT OF LOCAL LAWS, EMPLOYMENT OF WORKERS ETC.**

*The following are the responsibilities of the contractor in respect of observance of local laws, employment of personnel, payment of taxes etc. The subcontractor shall fully indemnify BHEL against any claims of whatsoever nature arising due to the failure of the contractor in discharging any of his responsibilities hereunder:*

*2.8.1 The contractor at all times during the continuance of this contract shall, in all his dealings with local labour for the time being employed on or in connection with the work, have due regard to all local festivals and religious and other customs.*

*2.8.2 The contractor shall comply with all applicable State and Central Laws, Statutory Rules, Maternity act, Regulations etc. such as contract labour(R&A) Act 1970, Minimum wage Act 1948, Payment of wages Act 1936,ESI Act 1948, EPF Act 1952, Employees' compensation Act 1923, Provision of Companies Act 1948 & rules thereof, The interstate Migrant Workmen 1979, The Karnataka Factories Rules 1969, Payment of Bonus Act 1965, Payment of Gratuity Act 1972. Child labour Prohibition act 1986, Karnataka Minimum Wage Act , Prevention of sexual harassment at work place Act 2013, Guidelines/notification related to Safai Karamchari Act , Equal Remuneration Act 1976, The company's instructions as issued from time to time in regard to working hours, wages, leaves, holidays etc. for labour as may be enacted by the Government during the tenure of the Contract and having force or jurisdiction at Site. The Contractor shall also give to the local Governing Body, Police and other relevant Authorities all such notices as may be required by the Law.*

*The contractor shall produce the following registers and forms:*

- Form XIII- Register of work men employed by contractor(Rule 75)*
- Form XIV- Employment Card issued by contractor( Rule 76)*
- Form XVI- Muster Roll ( Rule 78(1) (a)(i))*
- Form XVII- Register of Wages ( Rule 78(1) (a)(i))*
- Form XVIII- Register of wages cum Muster Roll(in case of weekly payment)*
- Form XIX- Wage slip ( Rule 78(b))*
- Form XX- Register of deduction for damages Or Loss Rule 78(1) (a)(ii)*
- Form XXI- Register of files Rule 78(1) (a)(ii)*
- Form XXII- Register of Advance Rule 78(1) (a)(ii)*
- Form XXIII- Register of Overtime Rule 78(1) (a)(iii)*
- Form XXIV- Return to be sent by the contractor to the Licensing officer (Rule 82(1))*

*2.8.3 The contractor shall obtain independent License under the Contract Labour (Regulations and Abolition Act)as required from the concerned Authorities based on the certificate (Form-V) issued by the Principal Employer/Customer*

2.8.4 The contractor shall pay all taxes, fees, license charges, deposits, duties, tolls, royalties, commission or other charges which may be levied on account of his operations in executing the contract.

2.8.5 While BHEL would pay the inspection fees and Registration fees of Boiler & explosive/Electrical Inspectorate, all other arrangements for site visits periodically by the Inspectorate to site, Inspection certificate etc. will have to be made by contractor. However, BHEL will not make any payment to the Inspectorate in connection with contractor's Welders/Electricians qualification tests etc.

2.8.6 Contractor shall be responsible for provision of Health and Sanitary arrangements (more particularly described in Contract Labour Regulation & Abolition Act), Safety precautions etc. as may be required for safe and satisfactory execution of contract.

2.8.7 The contractor shall be responsible for proper accommodation including adequate medical facilities for personnel employed by him.

2.8.8 The contractor shall be responsible for the proper behavior and observance of all regulations by the staff employed by him.

2.8.9 The contractor shall ensure that no damage is caused to any person/property of other parties working at site. If any such damage is caused, it is responsibility of the contractor to make good the losses or compensate for the same.

2.8.10 All the properties/equipment/components of BHEL/their Client loaned with or without deposit to the contractor in connection with the contract shall remain properties of BHEL/their Client.

2.8.11 The contractor shall use such properties for the purpose of execution of this contract. All such properties/equipment/components shall be deemed to be in good condition when received by the contractor unless he notifies within 48 hours to the contrary. The contractor shall return them in good condition as and when required by BHEL/their Client. In case of non-return, loss, damage, repairs etc, the cost thereof as may be fixed by BHEL Engineer will be recovered from the contractor

2.8.12 Any delay in completion of works/or non-achievement of periodical targets due to the reasons attributable to the contractor, the same may have to be compensated by the contractor either by increasing manpower and resources or by working extra hours and/or by working more than one shift. All these are to be carried out by the contractor at no extra cost.

2.8.13 The contractor shall arrange, coordinate his work in such a manner as to cause no hindrance to other agencies working in the same premises.

2.8.14 All safety rules and codes applied by the Client/BHEL at site shall be observed by the contractor without exception. The contractor shall be responsible for the safety of the equipment/material and works to be performed by him and shall maintain all light, fencing guards, slings etc. or other protection necessary for the purpose. Contractor shall also take such additional precautions as may be indicated from time to time by the Engineer with a view to prevent pilferage, accidents, fire hazards. Due precautions shall be taken against fire hazards and atmospheric conditions. Suitable number of Clerical staff, watch and ward, store keepers to take care of equipment/materials and construction tools and tackles shall be posted at site by the contractor till the completion of work under this contract. The contractor shall arrange for such safety devices as are necessary for such type of work and carry out the requisite site tests of handling equipment, lifting tools, tackles etc. as per prescribed standards and practices. Contractor has to ensure the implementation of Health, Safety and Environment (HSE) requirements as per directions given by BHEL/Customer. The contractor has to assist in HSE audit by BHEL/Customer and submit compliance Report. The contractor has to generate and submit record/reports as per HSE plan/activities as per instruction of BHEL/Customer. All tools, plant and equipment brought to the site shall become the property of BHEL and shall not be removed from the site without the prior written approval from BHEL. When the work is finally completed or the Contractor is determined for reasons other than the defaults of the contract, he shall forthwith remove from the site all tools, plants, equipment etc., (other than those as may have been provided by BHEL) and upon such removal, the same shall revert in, and become the property of the contractor.

2.8.15 The contractor will be directly responsible for payment of wages to his workmen on specified date of respective month declared as per applicable Labour Act. A pay roll sheet giving all the payments given to the workers and duly signed by the contractor's representative should be furnished to BHEL site for record purpose.

2.8.16 In case of any class of work for which there is no such specification as laid down in the contract, such work shall be carried out in accordance with the instructions and requirements of the Engineer.

2.8.17 Also, no idle charges will be admissible in the event of any stoppage caused in the work resulting in contractor's labour and Tools & Plants being rendered idle due to any reason at any time.

2.8.18 The contractor shall take all reasonable care to protect the materials and work till such time the plant/equipment has been taken over by BHEL or their Client whichever is earlier.

2.8.19 The contractor shall not stop the work or abandon the site for whatsoever reason of dispute, excepting force majeure conditions. All such problems/disputes shall be separately discussed and settled without affecting the progress of work. Such stoppage or abandonment shall be treated as breach of contract and dealt with accordingly

2.8.20 The contractor shall keep the area of work clean and shall remove the debris etc. while executing day-to-day work. Upon completion of work, the contractor shall remove from the vicinity of work, all scrap, packing materials, rubbish, unused and other materials and deposit them in places specified by the Engineer. The contractor will also demolish all the hutments, sheds, offices, etc. constructed and used by him and shall clean the debris. In the event of his failure to do so, the same will be arranged to be done by the Engineer and the expenses recovered from the contractor. If the work is executed in Factory premises, no hutment will be allowed.

2.8.21 The contractor shall execute the work in the most substantial and workman like manner in the stipulated time. Accuracy of work and timely execution shall be the essence of this contract. The contractor shall be responsible to ensure that the quality, assembly and workmanship conform to the dimensions and clearance given in the drawings and/ or as per the instructions of the Engineer.

2.8.22 The Contractor to note that some of BHEL's T&Ps/MMDs may not be insured. The Contractor will take necessary precautions and due care to protect the same while in his custody from any damage/ loss till the same is handed over back to BHEL. In case the damage / loss is due to carelessness/ negligence on the part of the contractor, the Contractor is liable to get them repair/ replaced immediately and in case of his failure to do so within a reasonable time, BHEL will reserve the right to recover the loss from the contractor.

2.8.23 The contractor shall provide all watchmen necessary, for the protection of the site, the work, the materials, the tools , plant, equipment and anything else lying on the site during the progress of the work. He shall solely be responsible for and shall take all reasonable and proper steps for protecting, securing , lighting and watching all places on or about the work and the site which may be dangerous to any person whom so ever.

2.8.24 **SITE DRAINAGE:** All water that may accumulate on the site during the process of the work, or in trenches and excavations shall be removed to the entire satisfaction of the Engineer-in-charge and at Contractors expense.

2.8.25 **INSPECTION OF THE WORK:** BHEL Officers concerned with the Contract shall have power at any time to inspect and examine any part of the work and the contractor shall give such facilities as may be required to given for such inspection and examination.

2.8.26 In case the contractor is required to undertake any work outside the scope of this contract, the rates payable shall be those mutually agreed upon if the item rates are not mentioned in existing contract

- i. For any item of wok required to be carried out after the contract has been awarded and which is not covered by Contractors Schedule but is covered by C.P.W.D. schedule of rates the rate payable for such a fresh item will be derived from updated C.P.W.D. schedule of rates by the method of proportion as follows:

- ii. *Rate as per estimated updated C.P.W.D DSR and loading tender excess (plus or minus) on pro-rata basis for nearest analogous items. For other items rate as per estimated C.P.W.D DSR and loading tender excess(plus or minus)*
- iii. *If rates are not available in C.P.W.D. DSR, deviated item rates will be derived from market rate with 15% profit and overheads.*

## **2.9 PROGRESS MONITORING, MONTHLY REVIEW AND PERFORMANCE EVALUATION**

*2.9.1 A detailed plan/programme for completion of the contractual scope of work as per the time schedule given in the contract shall be jointly agreed between BHEL and Contractor, before commencement of work . The above programme shall be supported by month wise deployment of resources viz Manpower, T&P, Consumables, etc. Progress will be reviewed periodically (Daily/Weekly/Monthly) vis a vis this jointly agreed programme. The Contractor shall submit periodical progress reports (Daily/Weekly/Monthly) and other reports/information including manpower, consumables, T&P mobilization etc as desired by BHEL.*

*2.9.2 Monthly progress review between BHEL and Contractor shall be based on the agreed programme as above, availability of inputs/fronts etc, and constraints if any, as per prescribed formats. Manpower, T&P and consumable reports as per prescribed formats shall be submitted by contractor every month. Release of RA Bills shall be contingent upon certification by BHEL Site Engineer of the availability of the above prescribed formats duly filled in and signed.*

*2.9.3 The burden of proof that the causes leading to any shortfall is not due to any reasons attributable to the contractor is on the contractor himself. The monthly progress review shall record shortfalls attributable to (i) Contractor, (ii) Force Majeure Conditions, and (iii) BHEL*

## **2.10 TIME OF COMPLETION**

*2.10.1 Time is essence of the contract. The time schedule shall be as prescribed in the Contract. The time for completion shall be reckoned from the date of commencement of work at Site as certified by BHEL Engineers*

*2.10.2 The entire work shall be completed by the contractor within the time schedule or within such extended periods of time as may be allowed by BHEL under clause 2.11*

## **2.11 EXTENSION OF TIME FOR COMPLETION**

*2.11.1 If the completion of work as detailed in the scope of work gets delayed beyond the contract period, the contractor shall request for an extension of the contract and BHEL at its discretion may extend the Contract.*

2.11.2 Based on the monthly reviews jointly signed, the works balance at the end of original contract period less the backlog attributable to the contractor shall be quantified, and the number of months of 'Time extension' required for completion of the same shall be jointly worked out. Within this period of 'Time extension', the contractor is bound to complete the portion of backlog attributable to the contractor. Any further 'Time extension' or 'Time extensions' at the end of the previous extension shall be worked out similarly.

2.11.3 However if any 'Time extension' is granted to the contractor to facilitate continuation of work and completion of contract, due to backlog attributable to the contractor alone, then it shall be without prejudice to the rights of BHEL to impose penalty/LD for the delays attributable to the contractor, in addition to any other actions BHEL may wish to take at the risk and cost of contractor.

2.11.4 A joint programme shall be drawn for the balance amount of work to be completed during the period of 'Time Extension', along with matching resources (with weightages) to be deployed by the contractor as per specified format. Review of the programme and record of shortfall shall be done every month of the 'Time extension' period in the same manner as is done for the regular contract period.

2.11.5 During the period of 'Time extension', contractor shall maintain their resources as per mutually agreed program

2.11.6 At the end of total work completion as certified by BHEL Engineer, and upon analysis of the total delay, the portion of time extensions attributable to (i) Contractor, (ii) Force majeure conditions, and (iii) BHEL, shall be worked out and shall be considered to be exhausted in the same order. The total period of time extensions shall be the sum of (i), (ii) and (iii) above and shall be equal to period between the scheduled date of completion and the actual date of completion of contract. LD shall be imposed/levied for the portion of time extensions attributable to contractor and recoverable from the dues payable to the contractor.

## **2.12 OVERRUN COMPENSATION (THIS CLAUSE IS NOT APPLICABLE IN BHEL FACTORY & TOWNSHIP PREMISES)**

2.12.1 Over Run Compensation (ORC) is payable by way of rate revisions for periods beyond original, contract period subject to the following terms and conditions.

2.12.2 Rates shall be increased by 10% for the first twelve months of one or more extensions beyond original contract period. For the next twelve months of further extensions if any, rates shall be increased as above by 10% over the previous twelve months, and similarly for each subsequent twelve months extension.

*2.12.3 Should there be any 'Time extension' for reasons attributable only to the contractor, then the work shall be executed by the contractor at the rates applicable for the period the work was planned*

*2.12.4 Payment of ORC shall be regulated as follows:*

*i) Contractor is entitled to Over Run Compensation (ORC) only for the portion of backlog attributable to BHEL.*

*ii) 50% of the compensation is allocated for deployment of resources agreed as per the joint programme drawn vide 2.11.4. Payment shall however be based on the actual deployment of resources for the month as certified by BHEL, as per weightages assigned therein*

*iii) 50% of the compensation, is allocated for achieving of planned progress agreed as per the joint programme drawn vide 2.11.4. Payment shall be on pro rata basis for actual achieved quantities*

*iv) Total Over Run Compensation shall be limited to 10% of the executed contract value as certified in Final Bill. For this purpose executed contract value excludes PVC, ORC, Supplementary/Additional Items and Extra Works done on Man-day rate basis*

*2.12.5 Contractor shall not be entitled for any Over Run Compensation (ORC) for the portion of backlog attributable to the contractor. Such works shall be executed at the rates applicable for the period the work was planned*

### **2.13 QUANTITY VARIATION**

***2.13.1 The quoted rates shall remain firm irrespective of any variations in the individual quantities.***

### **2.14 EXTRA WORKS**

*2.14.1 All rectifications/modifications, revamping, and reworks required for any reasons not attributable to the contractor, or needed due to any change in deviation from drawings and design of equipment, operation/maintenance requirements, mismatching, or due to damages in transit, storage and erection/commissioning, and other allied works which are not very specifically indicated in the drawings, but are found essential for satisfactory completion of the work, will be considered as extra works.*

*2.14.2 Extra works arising on account of the contractor's fault, irrespective of time consumed in rectification of the damage/loss, will have to be carried out by the contractor free of cost. Under such circumstances, any material and consumable required for this purpose will also have to be arranged by the contractor at his cost.*

2.14.3 All the extra work should be carried out by a separately identifiable gang, without affecting routine activities. Daily log sheets in the pro-forma prescribed by BHEL should be maintained and shall be signed by the contractor's representative and BHEL engineer. No claim for extra work will be considered/entertained in the absence of the said supporting documents i.e. daily log sheets. Signing of log sheets by BHEL engineer does not necessarily mean the acceptance of such works as extra works.

2.14.4 BHEL retains the right to award or not to award any of the major repair/rework/modification/rectification/fabrication works to the contractor, at their discretion without assigning any reason for the same

2.14.5 After eligibility of extra works is established and finally accepted by BHEL engineer/designer, payment will be released on competent authority's approval at the following rate.

**MAN-HOUR RATE FOR ELIGIBLE EXTRA WORKS:** Single composite average labour man-hour rate, including overtime if any, supervision, use of tools and tackles and other site expenses and incidentals, consumables for carrying out any major rework/repairs/rectification/modification/fabrication as certified by site as may arise during the course of erection, testing, commissioning or extra works arising out of transit, storage and erection damages, payment, if found due will be as per applicable minimum wage act

2.14.6 The above composite labour man hour rate towards extra works shall remain firm and not subject to any variation during execution of the work. PVC will not be applicable for extra works. Rate revision, Over Run Charges/compensation etc will not be applicable due to extra works.

2.14.7 Extra Works for Civil Packages shall be regulated as follows

i) Rates for Extra Works arising due to (1) non availability of BOQ (Rate Schedule), OR (2) change in Specifications of materials/works (3) rectification/modification/dismantling & re erecting etc due to no fault of Contractor, shall be in the order of the following:

a) Item rates are to be derived from similar nature of items in the BOQ (Rate Schedule) with applicable escalation derived from All India Consumer Price Index for Whole Sale Commodities.

b) As per applicable updated CPWD-DSR (or latest edition) with applicable escalation derived; Notification issued by the office of CPWD for 'Cost Index' in that Region where the project is being executed,

c) Item rates are to be worked out on the basis of prevailing market rates mutually agreed between BHEL and Contractor, plus 15% towards Contractor's overheads and profit.

*ii) PVC and ORC will not applicable be for (i) above.*

## **2.15 SUPPLEMENTARY ITEMS**

### **2.15.1 For NON Civil Works**

*Supplementary items are items/works required for completion of entire work but not specified in the scope of work. Subject to certification of such items/works as supplementary items by BHEL Engineer, rates shall be derived on the basis of any one of the following on mutual agreement:*

*i) Based on percentage breakup/rates indicated for similar/nearby items*

*ii) In case (i) above does not exist, then BHEL/site may derive the percentage breakup/rates to suit the type of work*

### **2.15.2 For Civil Works**

*i) Rates for Supplementary Works/Additional Works arising out due to additions/alterations in the original scope of works as per contract subject to certification of BHEL Engineer shall be worked out as under:*

*a) Item rates which are available in existing BOQ (Rate Schedule) shall be operated with applicable escalation derived from All India Consumer Price Index for Whole Sale Commodities*

*b) Items of works which are not available in existing BOQ shall be operated as an 'Extra Works' and rate shall be derived as per clause no 2.14*

*ii) Execution of Supplementary Works/Additional Works through the Contractor shall be at the sole discretion of BHEL, and shall be considered as part of executed contract value for the purpose of Quantity Variation as per clause 2.13*

*iii) BHEL Engineer's decision regarding fixing the rate as above is final and binding on the contractor.*

*iv) PVC and ORC will not be applicable for (i) above.*

## **2.16 STRIKES & LOCKOUT**

*2.16.1 The contractor will be fully responsible for all disputes and other issues connected with his labour/employee. In the event of the contractor's labour/employee resorting to strike or the Contractor resorting to lockout and if the strike or lockout declared is not settled within a period of 15 days, BHEL shall have the right to get the work executed through any other*

*agencies and the cost so incurred by BHEL along with Overhead charges of 35% shall be deducted from the Contractor's bills along with overhead of 35%*

*2.16.2 For all purposes whatsoever, the employees of the contractor shall not be deemed to be in the employment of BHEL*

## **2.17 FORCE MAJEURE**

*The following shall amount to Force Majeure:-*

*2.17.1 Acts of God, act of any Government, War, Sabotage, Riots, Strike, Civil commotion, Police action, Revolution, Flood, Fire, Cyclones, Earth quake and Epidemic and other similar causes over which the contractor has no control.*

*2.17.2 If the contractor suffers delay in the due execution of the contractual obligation due to delays caused by force majeure as defined above, the agreed time of completion of the job covered by this contract or the obligations of the contractor shall be extended by a period of time equal to period of delay, provided that on the occurrence of any such contingency, the contractor immediately reports to BHEL in writing the causes of delay and the contractor shall not be eligible for any compensation.*

## **2.18 ARBITRATION & RECONCILIATION**

*2.18.1 In case amicable settlement is not reached in the event of any dispute or difference arising out of the execution of the Contract or the respective rights and liabilities of the parties or in relation to interpretation of any provision by the Contractor in any manner touching upon the Contract, such dispute or difference shall (except as to any matters, the decision of which is specifically provided for therein) be referred to the sole arbitration of the arbitrator appointed by BHEL/In charge.*

*The award of the Arbitrator shall be binding upon the parties to the dispute Subject as aforesaid, the provisions of Arbitration and Reconciliation Act 1996 (India) or statutory modifications or reenactments thereof and the rules made there under and for the time being in force shall apply to the arbitration proceedings under this clause. The venue of the arbitration shall be the place from which the contract is issued or such other place as the Arbitrator at his discretion may determine*

*2.18.2 In case of Contract with Public Sector Enterprise (PSE) or a Government Department, the following shall be applicable:*

*In the event of any dispute or difference relating to the interpretation and application of the provisions of the Contract, such dispute or difference shall be referred to by either party to the arbitration of one of the arbitrators in the department of public enterprises. The award of the arbitrator shall be binding upon the parties to the dispute, provided, however, any party aggrieved by such award may make further reference for setting aside or revision of the award to the Law Secretary, Department of Legal Affairs, Ministry of Law and Justice, Government of India. Upon such reference the dispute shall be decided by the Law Secretary or the Special Secretary or Additional Secretary when so authorized by the Law Secretary, whose decision shall bind the parties hereto finally and conclusively.*

*2.18.3 The cost of arbitration shall be borne equally by the parties.*

*2.18.4 Work under the contract shall be continued during the arbitration proceedings*

## **2.19 PAYMENTS**

*Payments to Contractors are made in any one of the following forms*

### *2.19.1 Running Account Bills (RA Bills)*

*i) These are for interim payments when the contracts are in progress. The bills for such interim payments are to be prepared by Contractor in prescribed formats (RA Bill forms).*

*ii) Payments shall be made according to the extent of work done as per measurements taken up to the end of the calendar month and in line with the terms of payments described in the Tender documents along with relevant statutory documents applicable for the work.*

*iii) Recoveries on account of electricity, water, statutory deductions, etc are made as per terms of contract*

*iv) Full rates for the work done shall be allowed only if the quantum of work has been done as per the specifications stipulated in the contract. If the work is not executed as per the stipulated specifications, BHEL may ask the contractor to re do the work according to the required specifications, without any extra cost. However, where this is not considered necessary 'OR' where the part work is done due to factors like non-availability of material to be supplied by BHEL 'OR' non availability of fronts 'OR' non availability of drawings, fraction payment against full rate, as is considered reasonable, may be allowed with due regard for the work remaining to be done. BHEL decision in this regard will be final and binding on the contractor.*

v) In order to facilitate part payment, BHEL Site Engineer at his discretion may further split the contracted rates/percentages to suit site conditions, cash flow requirements according to the progress of work

#### **2.19.2 Final Bill**

*Final Bill* is used for final payment on closing of Running Account for works or for single payment after completion of works. *Final Bill* shall be submitted as per prescribed format after completion of works as per scope and upon material reconciliation, along with the following.

i) *No Claim Certificate* by contractor

ii) *Clearance certificates* where ever applicable viz *Clearance Certificates* from Customer, various *Statutory Authorities* like Labour department, PF Authorities, Commercial Tax Department, etc

iii) *Indemnity bond* as per prescribed format BHEL shall settle the final bills after deducting all liabilities of Contractor to BHEL

#### **2.20 PERFORMANCE GUARANTEE FOR WORKMANSHIP**

2.20.1 Even though the work will be carried out under the supervision of BHEL Engineers the Contractor will be responsible for the quality of the workmanship and shall guarantee the work done for a period of as mentioned in the contract/NIT from the date of commencement of guarantee period as defined in Technical Conditions of Contract, for good workmanship and shall rectify free of cost all defects due to faulty erection detected during the guarantee period. In the event of the Contractor failing to repair the defective works within the time specified by the Engineer, BHEL may proceed to undertake the repairs of such defective works at the Contractor's risk and cost, without prejudice to any other rights and recover the same from the balance security deposit.

2.20.2 BHEL shall release the balance security deposit subject to the following

i) Contractor has submitted *Final Bill*

ii) *Guarantee period* as per contract has expired

iii) Contractor has furnished *No Claim Certificate* in specified format

iv) BHEL Site Engineer/Construction Manager has furnished the *No Demand Certificate* in specified format

v) Contractor has carried out the works required to be carried out by him during the period of Guarantee and all expenses incurred by BHEL on carrying out such works is included for adjustment from the Guarantee money refundable.

## **2.21 CLOSING OF CONTRACTS**

The Contract shall be considered completed and closed upon completion of all contractual obligations and settlement of Final Bill or completion of Guarantee period whichever is later. Upon closing of Contract, BHEL shall issue a completion certificate as per standard format, based on specific request of Contractor.

## **2.22 REVERSE AUCTION/PRICE BID OPENING:**

- BHEL reserves the right to go for reverse auction at any point of time before opening of Price Bid.
- Bids with non-acceptance of reverse auction will be liable for rejection.
- Opening of Price Bid at discretion of BHEL.
- BHEL shall be at liberty to cancel the tender at any time, before ordering, without assigning any reason.

## **2.23 SUSPENSION OF BUSINESS DEALINGS**

BHEL reserves the right to take action against Contractors who either fail to perform or Tenderers/Contractor who indulge in malpractices, by suspending business dealings with them in line with BHEL guidelines issued from time to time.

## **2.24 OTHER ISSUES**

2.24.1 Value of Non judicial Stamp Paper for Bank Guarantees and for Contract Agreement shall be not less than Rs 200/- unless otherwise required under relevant statutes.

2.24.2 In case of any conflict between the General Conditions of Contract and Special Conditions of Contract, provisions contained in the Special Conditions of Contract shall prevail.

2.24.3 Unless otherwise specified in NIT, offers from consortium /JVs shall not be considered.

2.24.4 BHEL may not insist for signing of Contract Agreements in respect of low value and short time period contracts

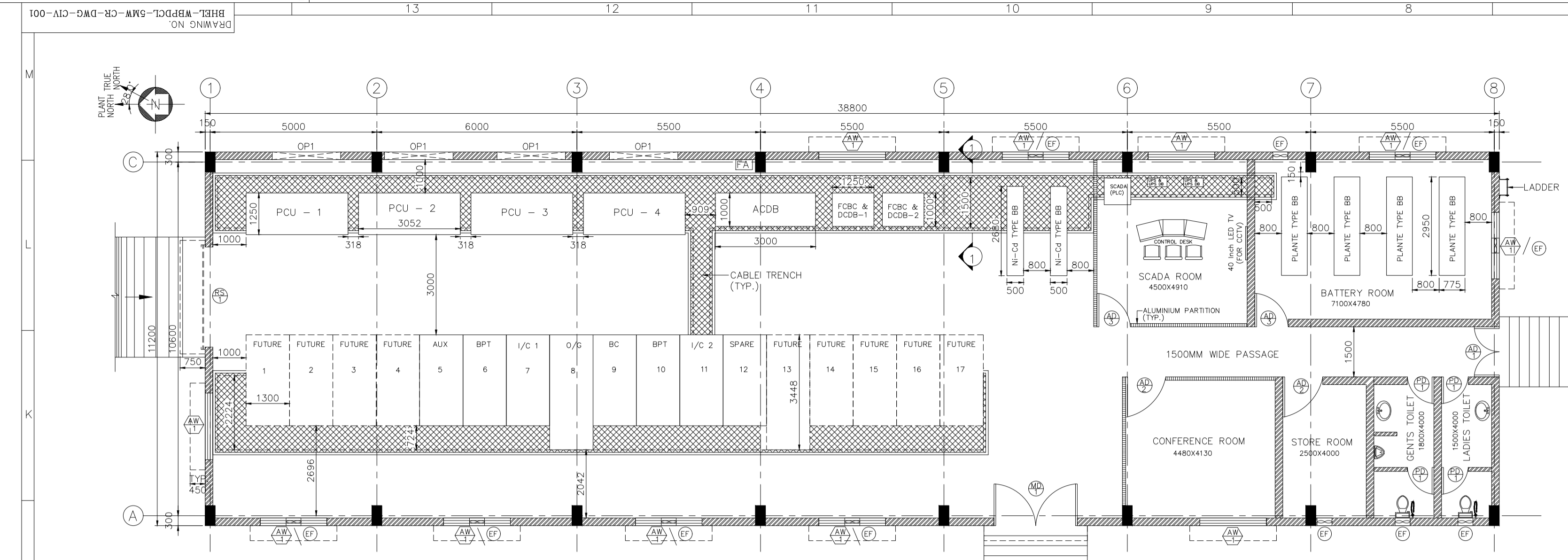

GROUND FLOOR PLAN  
(SCALE 1:75)

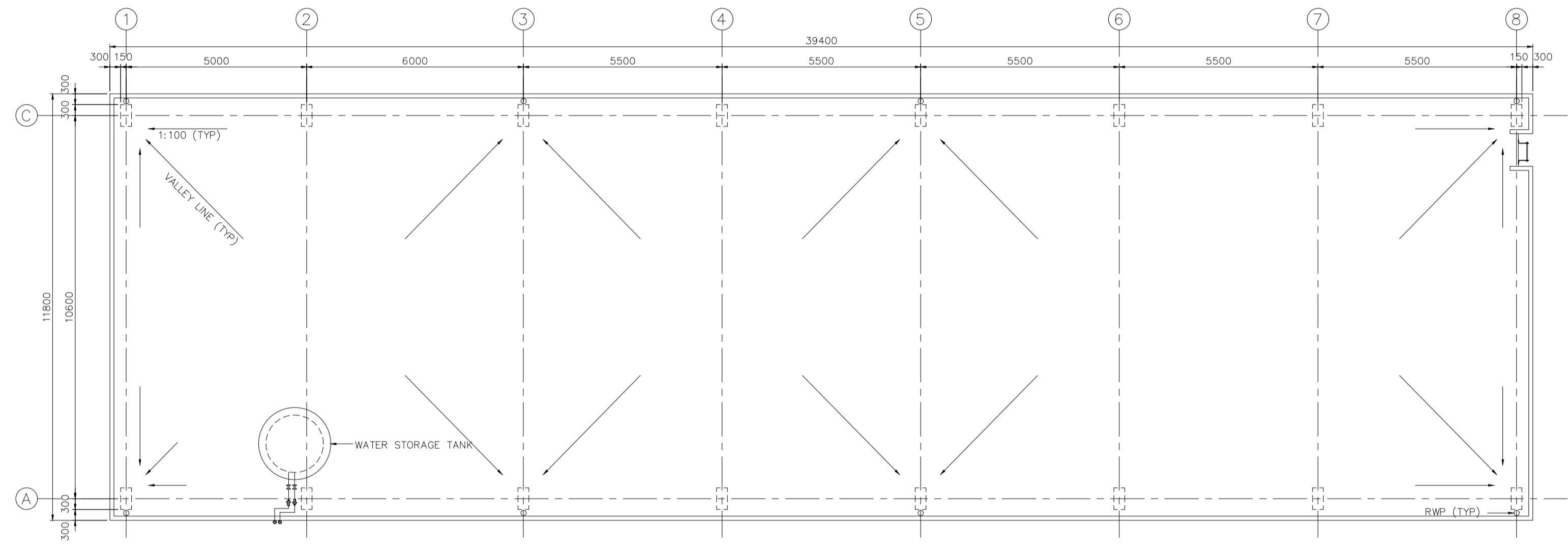

TERRACE FLOOR PLAN  
(SCALE 1:75)

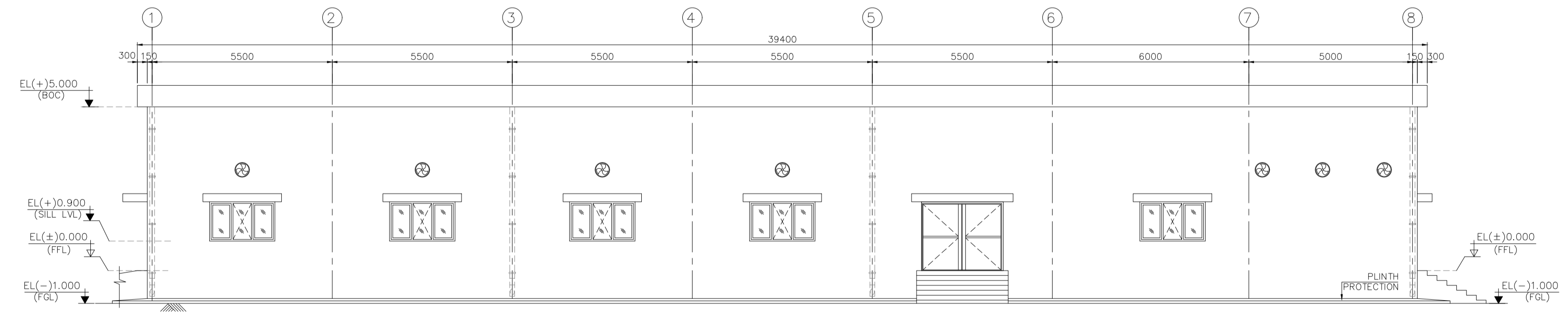

WEST ELEVATION  
(SCALE 1:75)

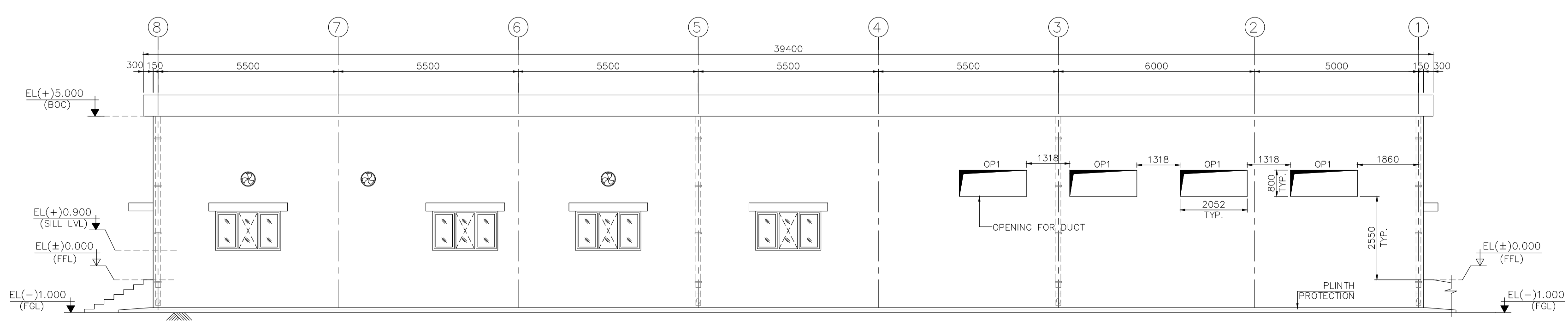

EAST ELEVATION  
(SCALE 1:75)

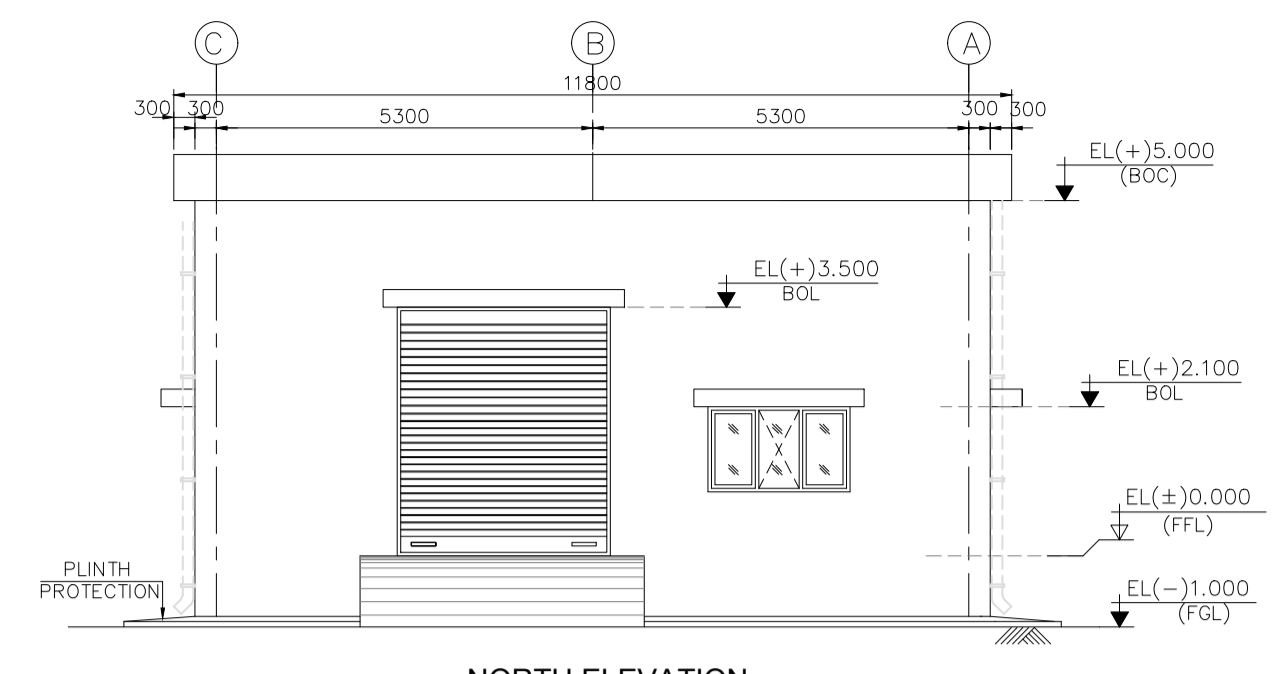

NORTH ELEVATION  
(SCALE 1:75)

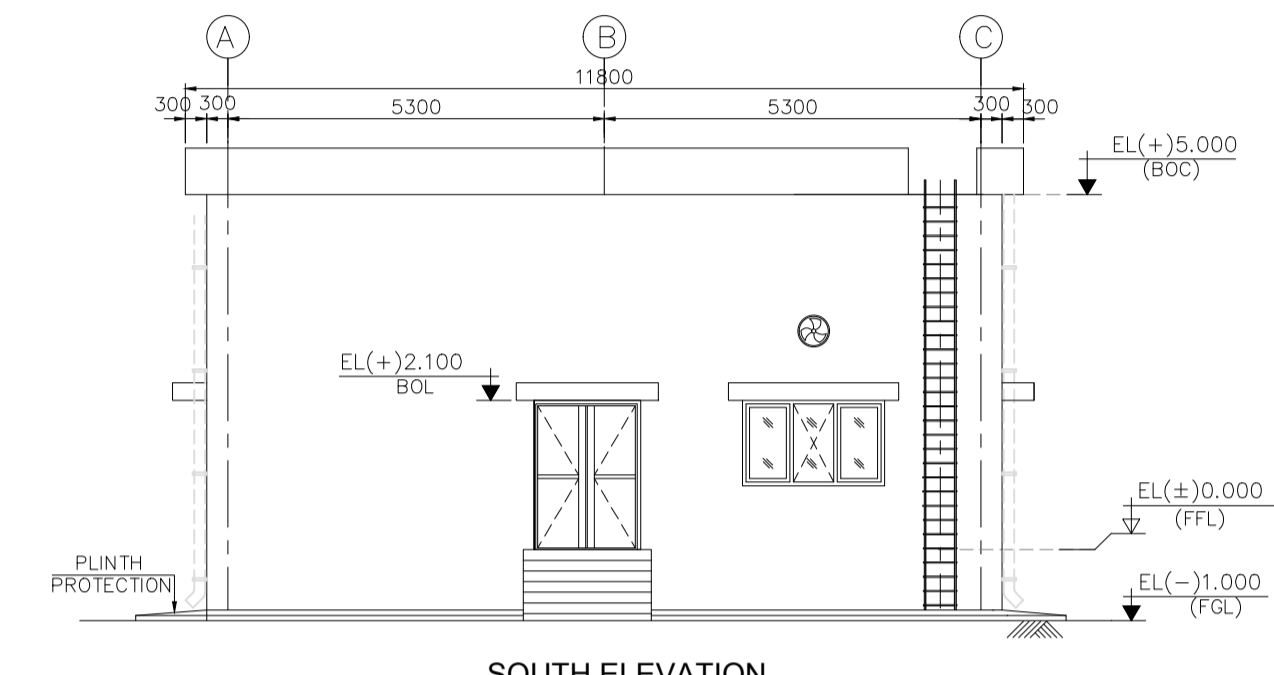

SOUTH ELEVATION  
(SCALE 1:75)

FINISH SCHEDULE:

SERIAL NUMBER	ROOMS	FLOORS				INTERNAL WALLS		CEILING	EXTERNAL WALL
		40MM THK. CEMENT CONCRETE (PS FLOORING) (1:2:4)	40MM THK. HEAVY DUTY VERIFIED TILE FLOORING (TILE 8MM THK.)	ACID/ALKALI RESISTANT TILE FLOORING WITH 2100 HIGH DADO	40MM THK. CERAMIC TILE (8MM THK.) FLOORING WITH GLAZED TILE (8MM THK.) 2100MM HEIGHT DADO	SKIRTING			
						CEMENT SKIRTING (100MM HEIGHT)	VERIFIED TILE SKIRTING (100MM HEIGHT)		
1	STORE ROOM	•				•	•	•	HEAT REFLECTIVE SYNTHETIC ENAMEL PAINT
2	SCADA ROOM		•			•	•	•	
3	CONFERENCE ROOM		•			•	•	•	
4	TOILET				•			•	
5	BATTERY ROOM			•			•	•	
6	STEPS					•		•	
7	EQUIPMENT AREA		•				•		

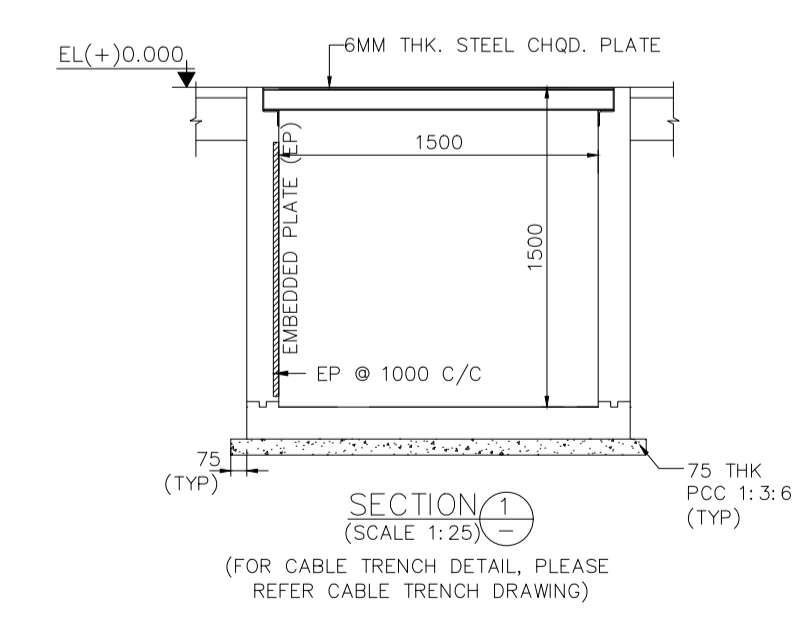

SECTION 1  
(SCALE 1:25)  
(FOR CABLE TRENCH DETAIL, PLEASE REFER CABLE TRENCH DRAWING)

- NOTES**
- THIS DRAWING SHALL BE READ IN CONJUNCTION WITH CONTRACT TERMS AND CONDITIONS, SPECIFICATION AND SCHEDULE OF ITEMS.
  - ALL DIMENSIONS ARE IN MILLIMETER AND LEVELS ARE IN METERS, UNO.
  - FINISHED FLOOR LEVEL CORRESPONDS TO EL(+).0.000M WHICH IS 1000MM ABOVE FINISHED GRADE LEVEL.
  - FOR WINDOW FLOAT GLASS OF 4MM, FOR DOORS AND PARTITION FLOAT CLASS OF 5.5MM.
  - INTERNAL WALL PLASTERING 12MM AND EXTERNAL WALL PLASTERING 18MM.
  - CEILING PLASTERING SHALL BE 6MM THK. IN 1:3 CEMENT SAND MORTAR.

**LEGEND**

	230 THK BRICK WALL		FGL - FINISHED GROUND LEVEL
	175 THK BRICK WALL		TOC - TOP OF CONCRETE
	ALUMINIUM PARTITION		ELEVATION
	TYP - TYPICAL		TOP - TOP OF PARAPET
	FFL - FINISHED FLOOR LEVEL		BOL - BOTTOM OF CONCRETE
	UNO - UNLESS NOTED OTHERWISE		LVL - LEVEL
	OP1 - OPENING FOR DUCT		RWP - RAIN WATER PIPE

**SCHEDULE OF JOINERY**

SYMBOL	Nos	SILL LVL. AT EL...	MASONRY OPENING WIDTH	OPENING HEIGHT	REMARKS
	01	+0.000	3000	3500	ROLLING SHUTTER
	01	+0.000	2500	2100	MAIN DOOR - ALUMINIUM FRAMED WITH GLAZED DOOR - DOUBLE SHUTTER
	01	+0.000	1500	2100	ALUMINIUM FRAMED WITH GLAZED DOOR - DOUBLE SHUTTER
	02	+0.000	1200	2100	ALUMINIUM FRAMED WITH GLAZED DOOR - SINGLE SHUTTER
	02	+0.000	1000	2100	ALUMINIUM FRAMED WITH GLAZED DOOR - SINGLE SHUTTER
	04	+0.000	800	2100	PVC DOOR
	11	+0.900	2000	1200	ALUMINIUM FRAMED GLAZED WINDOW
	11	+2.850	450*		EXHAUST FAN

**SCHEDULE OF OPENING**

MKD	Nos	€ OF OPENING	MASONRY OPENING WIDTH	OPENING HEIGHT	REMARKS
OP1	04	EL(+).2.550	2052	800	DUCT ENTRY

THIS DRAWING SHOULD BE READ IN CONJUNCTION WITH DRG NO. BHBL-WBPDCL-CIV-CR-002, MAIN CONTROL ROOM EQUIPMENT LAYOUT

**TENTATIVE TENDER DRAWING**

DEPT. SC&PV  
STATUS CONTRACT  
DISTRIBUTION

**5MWp FLOATING SOLAR PV PLANT FOR WBPDCL**

**BHARAT HEAVY ELECTRICALS LTD**  
ELECTRONICS DIVISION, BANGALORE

TITLE CONTROL ROOM BUILDING-ARCHITECTURE PLAN, ELEVATIONS, & FINISHING.

SCALE 1:100 DRAWING NO. BHBL-WBPDCL-5MW-CR-DWG-CIV-001 SHEET 1 OF 1 REV. 01

REV.	DATE	ALTD	CHD	APPD	REV.	DATE	ALTD	CHD	APPD	REV.	DATE	ALTD	CHD	APPD

REVISIONS TO BE INCORPORATED IN THE DRAWING.

**PRICE BID**

**Construction of RCC Control Room buildings and other associated works for 5 MW floating Solar PV power plant for WBPDC, SAGARDIGHI at West Bengal”.**

Sl. No.	Description of Work	Unit	Qty.	ITEM RATE (Excluding GST)	Amount
<b>(A) Civil Works</b>					
1	Earth work in excavation by mechanical means (Hydraulic excavator) / manual means over areas (exceeding 30cm in depth. 1.5 m in width as well as 10 sqm on plan) including disposal of excavated earth, lead upto 2km and lift upto 1.5m, disposed earth to be levelled and neatly dressed.all type of soil as per direction of Engineer in charge.	Cum	866.00	99.75	86385.58
2	Earth work in excavation by mechanical means (Hydraulic excavator) / manual means over areas (exceeding 30cm in depth. 1.5 m in width as well as 10 sqm on plan) including disposal of excavated earth, lead upto 2km and lift upto 1.5m, disposed earth to be levelled and neatly dressed.in soft rock complete as per direction of Engineer in charge.	Cum	162.00	175.07	28361.60
3	Earth work in excavation by mechanical means (Hydraulic excavator) / manual means over areas (exceeding 30cm in depth. 1.5 m in width as well as 10 sqm on plan) including disposal of excavated earth, lead upto 2km and lift upto 1.5m, disposed earth to be levelled and neatly dressed.in Hard rock complete as per direction of Engineer in charge.	Cum	54.00	490.88	26507.61
4	Filling available excavated earth/murram (excluding rock) in trenches, plinths, sides of foundations etc. in layers not exceeding 20cm in depth, consolidating each deposited layer by ramming and watering, lead up to 2 km and lift upto 1.5 m complete as per direction of Engineer in charge.	Cum	674.00	99.59	67126.36
5	Providing and laying in position cement concrete of specified grade excluding the cost of centering and shuttering - All work up to plinth level : 1:3:6 (1 Cement : 3 coarse sand (zone-III) : 6 graded stone aggregate 20 mm nominal size).	Cum	115.00	3902.18	448751.16
6	Providing and laying in position cement concrete of specified grade excluding the cost of centering and shuttering - All work up to plinth level :1:4:8 (1Cement : 4 coarse sand : 8 graded stone aggregate 20 mm nominal size) complete as per direction of Engineer in charge.	Cum	5.00	3546.69	17733.47
7	Providing and laying in position cement concrete of specified grade excluding the cost of centering and shuttering - All work upto floor V level : 1:2:4 (1 cement : 2 coarse sand : 4 graded stone aggregate 20/10mm mm nominal size) complete as per direction of Engineer in charge.	Cum	98.00	4763.74	466846.66
8	Providing and laying in position machine batched and machine mixed design mix M-25 grade cement concrete for reinforced cement concrete work, using cement content as per approved design mix, including pumping of concrete to site of laying but excluding the cost of centering, shuttering, and reinforcement, including admixtures in recommended proportions as per IS: 9103 to accelerate, retard setting of concrete, improve workability without impairing strength and durability as per direction of Engineer-in-charge. All works upto floor V level	Cum	319.00	5423.81	1730196.67
9	Providing and laying in position machine batched and machine mixed design mix M-30 grade cement concrete for reinforced cement concrete work, using cement content as per approved design mix, including pumping of concrete to site of laying but excluding the cost of centering, shuttering, and reinforcement, including admixtures in recommended proportions as per IS: 9103 to accelerate, retard setting of concrete, improve workability without impairing strength and durability as per direction of Engineer-in-charge. All works upto floor V level	Cum	5.00	5478.86	27394.29
10	Centering and shuttering including strutting, propping etc. and removal of form for :Foundations, footings, bases of columns etc. for mass complete as per direction of Engineer in charge.	sqm	261.00	153.61	40091.79
11	Centering and shuttering including strutting, propping etc. and removal of form for Columns, Pillars, Piers, Abutments, Posts and Struts complete as per direction of Engineer in charge. FOR ANY HEIGHT	sqm	268.00	370.54	99303.97
12	Centering and shuttering including strutting, propping etc. and removal of form for all heights : Lintels, beams, plinth beams, girders, bressumers and cantilevers FOR ANY HEIGHT	sqm	460.00	271.58	124925.33
13	Centering and shuttering including strutting, propping etc. and removal of form for Suspended floors, roofs, landings, balconies and access platform complete as per direction of Engineer in charge. FOR ANY HEIGHT	sqm	700.00	334.46	234123.12
14	Centering and shuttering including strutting, propping etc. and removal of form for all heights : Walls (any thickness) including attached pilasters, buttresses, plinth and string courses etc.	sqm	469.00	299.85	140630.21
15	Supplying and filling in plinth with sand/murram under floors, including watering,ramming, consolidating and dressing complete.	Cum	97.00	726.86	70505.23
16	Dry stone SOLING AVERAGE 22.5 cm thick including supply of stones, ramming with sand and preparing surface complete.	sqm	485.00	395.72	191925.56

**PRICE BID**

**Construction of RCC Control Room buildings and other associated works for 5 MW floating Solar PV power plant for WBPDC, SAGARDIGHI at West Bengal”.**

Sl. No.	Description of Work	Unit	Qty.	ITEM RATE (Excluding GST)	Amount
17	Brick work with common burnt clay F.P.S. (non modular) bricks of class designation 7.5 up to floor V level in all shapes and sizes in : Cement mortar 1:6 (1 cement : 6 coarse sand)	cum	162.00	3953.41	640451.87
18	Half brick masonry with common burnt clay F.P.S. (non modular) bricks of class designation 7.5 up to floor V level. Cement mortar 1:4 (1 cement :4 coarse sand)	sqm	10.00	505.97	5059.69
19	15 mm cement plaster on the rough side of single or half brick wall of mix :1:6 (1 cement: 6 coarse sand). EXTERNAL PLASTER	sqm	741.00	154.12	114205.29
20	12 mm cement plaster of mix : 1:4 (1 cement: 4 coarse sand): INTERNAL PLASTER	sqm	791.00	143.23	113297.46
21	6 mm cement plaster of mix : 1:3 (1 cement : 3 fine sand) CEILING PLASTER	sqm	656.00	113.89	74711.58
22	Providing and laying vitrified floor tiles in different sizes (thickness should be 8mm) with water absorption less than 0.08% and conforming to IS: 15622, of approved make, in all colours and shades, laid on 30mm thick cement mortar 1:4 (1 cement : 4 coarse sand), jointing with grey cement slurry @ 3.3kg/sqm including grouting the joints with white cement and matching pigments etc., complete. Size of Tile 600x600 mm	Sqm	45.00	886.56	39895.42
23	Providing and laying anti skid Glazed Ceramic floor tiles of size 300x300 mm or more (thickness should be 8mm), of 1st quality conforming to IS : 15622, of approved make, in colours as approved by Engineer In-charge, laid on 30 mm thick cement mortar 1:4 (1 Cement: 4 Coarse sand), jointing with grey cement slurry @ 3.3kg/ sqm including grouting the joints with white cement and matching pigments etc., complete.	sqm	13.00	651.38	8467.95
24	Providing and fixing 1st quality ceramic glazed wall tiles conforming to IS: 15622 (thickness should be 6mm), of approved make, in all colours, shades in skirting, dados, over 12 mm thick bed of cement mortar 1:3 (1 cement : 3coarse sand) and jointing with grey cement slurry @ 3.3kg per sqm,including pointing in white cement mixed with pigment of matching shade complete.	Sqm	61.00	589.88	35982.78
25	Providing & fixing Acid and alkali resistant tile in flooring on a bed of 30 mm thick mortar 1:4 (1 acid proof cement : 4 coarse sand). Tile thickness should be 20mm.	Sqm	34.00	850.09	28903.17
26	Providing & fixing dado/skirting Acid and alkali resistant tile on 12 mm thick mortar 1:4 (1 acid proof cement : 4 coarse sand). Tile thickness should be 12mm.	Sqm	50.00	905.73	45286.56
27	Cement concrete flooring (IPS) 1:2:4 (1 cement : 2 coarse sand : 4 graded stone aggregate) finished with a floating coat of neat cement, including cement slurry, but excluding the cost of nosing of steps etc. complete. 40 mm thick with 10 mm nominal size stone aggregate IS 2571	sqm	184.00	287.18	52840.97
28	Cement plaster skirting up to 30 cm height, with cement mortar 1:3 (1 cement : 3 coarse sand), finished with a floating coat of neat cement. 18 mm thick	sqm	12.00	277.24	3326.88
29	Finishing with Epoxy paint/COATING 2mm thk heavy duty industrial grade (two or more coats) at all locations prepared and applied as per manufacturer's specifications including appropriate priming coat, preparation of surface, etc. complete. On concrete work	sqm	196.00	98.60	19326.38
30	Kota stone slabs 20 mm thick in risers of steps, skirting, dado and pillars laid on 12 mm (average) thick cement mortar 1:3 (1 cement: 3 coarse sand) and jointed with grey cement slurry mixed with pigment to match the shade of the slabs, including rubbing and polishing complete.	sqm	15.00	980.65	14709.82
31	Providing and laying Polished Granite stone flooring in required design and patterns, in linear as well as curvilinear portions of the building, all complete as per the architectural drawings, with 18 mm thick stone slab over 20 mm (average) thick base of cement mortar 1:4 (1 cement : 4 coarse sand), laid and jointed with cement slurry and pointing with white cement slurry admixed with pigment of matching shade, including rubbing, curing and polishing etc. all complete as specified and as directed by the Engineer-in-Charge. Polished Granite stone slab, colour as approved by Engineer In-charge.	sqm	5.00	2326.66	11633.29

**PRICE BID**

**Construction of RCC Control Room buildings and other associated works for 5 MW floating Solar PV power plant for WBPDC, SAGARDIGHI at West Bengal”.**

Sl. No.	Description of Work	Unit	Qty.	ITEM RATE (Excluding GST)	Amount
32	Providing and fixing stone slab with table rubbed, edges rounded and polished, of size 75x50 cm deep and 1.8 cm thick, fixed in urinal partitions by cutting a chase of appropriate width with chase cutter and embedding the stone in the chase with epoxy grout or with cement concrete 1:2:4 (1 cement : 2 coarse sand : 4 graded stone aggregate 6 mm nominal size) as per direction of Engineer-in-charge and finished smooth. Granite Stone of approved shade	sqm	1.00	2242.90	2242.90
33	Providing and applying plaster of paris putty of 2 mm thickness of approved brand over plastered surface to prepare the surface even and smooth complete.	sqm	1447.00	94.01	136033.05
34	Finishing walls with Acrylic Smooth exterior weather proof/Heta reflective paint of required shade : New work (Two or more coat applied @ 1.67 ltr/10 sqm over and including priming coat of exterior weather proof primer applied @ 2.20 kg/10 sqm) EXTERNAL	sqm	741.00	76.07	56369.06
35	Wall painting with acrylic emulsion paint (for Internal walls)of approved brand and manufacture to give an even shade : Two or more coats on new work with primer	sqm	648.00	66.88	43341.09
36	White washing with lime to give an even shade : New work (three or more coats) CEILING	sqm	656.00	13.66	8962.27
37	Applying one coat of water thinnable cement primer of approved brand and manufacture on wall surface : Water thinnable cement primer CEILING	sqm	656.00	29.26	19197.45
38	Supplying and fixing rolling shutters of approved make, made of required size M.S. laths, interlocked together through their entire length and jointed together at the end by end locks, mounted on specially designed pipe shaft with brackets, side guides and arrangements for inside and outside locking with push and pull operation complete, including the cost of providing and fixing necessary 27.5 cm long wire springs manufactured from high tensile steel wire of adequate strength conforming to IS: 4454 - part 1 and M.S. top cover of required thickness for rolling shutters. 80x1.25 mm M.S. laths with 1.25 mm thick top cover	sqm	9.00	1834.35	16509.16
39	Providing and fixing pressed steel door frames conforming to IS: 4351, manufactured from commercial mild steel sheet of 1.60 mm thickness, including hinges, jamb, lock jamb, bead and if required angle threshold of mild steel angle of section 50x25 mm, or base ties of 1.60 mm, pressed mild steel welded or rigidly fixed together by mechanical means, including M.S. pressed butt hinges 2.5 mm thick with mortar guards, lock strike-plate and shock absorbers as specified and applying a coat of approved steel primer after pre-treatment of the surface as directed by Engineer-in-charge: Profile C: Fixing with adjustable lugs with split end tail to each jamb	meter	20.00	287.93	5758.63
40	Providing and fixing ISI marked flush door (MDF) shutters conforming to IS : 2202 (Part I) decorative type, core of block board construction with frame of 1st class hard wood and well matched teak 3 ply veneering with vertical grains or cross bands and face veneers on both faces of shutters. 35 mm thick including ISI marked Stainless Steel butt hinges with necessary screws	sqm	7.00	1971.25	13798.74
41	Providing and fixing thermal insulation of ceiling (under deck insulation) with mineral wool, density 45kg / m3, fixed to ceiling as per direction of Engineer In-charge.	sqm	41.00	336.68	13803.85
42	False ceiling: 600 x 600 x 12 mm thick gypsum board with one coat of primer and two or more coat of Acrylic emulsion paint. The suspension system shall consist of 6 mm diameter galvanised steel rods suspended from ceiling supporting by GI grid of 38 x 25 x 1.5 mm and cross tie of 25 x 25 x 1.5 mm and GI angle of 25 x 25 x 1.5 mm., for all heights, as per specifications, drawings and as directed by engineer-in-charge.	Sqm	41.00	638.51	26178.93

**PRICE BID**

**Construction of RCC Control Room buildings and other associated works for 5 MW floating Solar PV power plant for WBPDC, SAGARDIGHI at West Bengal”.**

Sl. No.	Description of Work	Unit	Qty.	ITEM RATE (Excluding GST)	Amount
43	Providing and fixing aluminium work for doors, windows, ventilators and partitions with extruded built up standard tubular sections/ appropriate Z sections and other sections of approved make conforming to IS: 733 and IS: 1285, fixing with dash fasteners of required dia and size, including necessary filling up the gaps at junctions, i.e. at top, bottom and sides with required EPDM rubber/ neoprene gasket etc. Aluminium sections shall be smooth, rust free, straight, mitred and jointed mechanically wherever required including cleat angle, Aluminium snap beading for glazing / paneling, C.P. brass / stainless steel screws, all complete as per architectural drawings and the directions of Engineer-in-charge. (Glazing, paneling and dash fasteners to be paid for separately) : <b>Anodised aluminium (anodised transparent or dyed to required shade according to IS: 1868, Minimum anodic coating of grade AC 25)</b>	kg	490.00	290.51	142347.74
44	For shutters of doors, windows & ventilators including providing and fixing hinges/ pivots and making provision for fixing of fittings wherever required including the cost of EPDM rubber / neoprene gasket required (Fittings shall be paid for separately) <b>Anodised aluminium (anodised transparent or dyed to required shade according to IS: 1868, Minimum anodic coating of grade AC 25)</b>	kg	201.00	337.91	67919.27
45	Providing and fixing 12 mm thick pre-laminated particle board flat pressed three layer or graded wood particle board conforming to IS: 12823 Grade I Type II, in panelling fixed in aluminium doors, windows shutters and partition frames with C.P. brass / stainless steel screws etc. complete as per architectural drawings and directions of Engineer-in-charge. Pre-laminated particle board with decorative lamination on both sides	sqm	54.00	686.35	37062.75
46	Providing and fixing glazing in aluminium door, window, ventilator shutters and partitions etc. with EPDM rubber / neoprene gasket etc. complete as per the architectural drawings and the directions of Engineer-in-charge . (Cost of aluminium snap beading shall be paid in basic item): With float glass panes of 4.0 mm thickness	sqm	23.00	587.27	13507.16
47	Providing and fixing glazing in aluminium door, window, ventilator shutters and partitions etc. with EPDM rubber / neoprene gasket etc. complete as per the architectural drawings and the directions of Engineer-in-charge . (Cost of aluminium snap beading shall be paid in basic item): With float glass panes of 6.00 mm thickness	sqm	49.00	795.13	38961.29
48	Providing and fixing anodised aluminium grill (anodised transparent or dyed to required shade according to IS: 1868 with minimum anodic coating of grade AC 15) of approved design/pattern, with approved standard section and fixed to the existing window frame with C.P. brass/ stainless steel screws @ 200 mm centre to centre, including cutting the grill to proper opening size for fixing and operation of handles and fixing approved anodised aluminium standard section around the opening, all complete as per requirement and direction of Engineer-in-charge. (Only weight of grill to be measured for payment).	kg	126.00	323.81	40799.96
49	Providing and fixing aluminium tower bolts, ISI marked, anodised (anodic coating not less than grade AC 10 as per IS : 1868 ) transparent or dyed to required colour or shade, with necessary screws etc. complete : 300x10 mm	each	4.00	78.96	315.85
50	Providing and fixing aluminium tower bolts, ISI marked, anodised (anodic coating not less than grade AC 10 as per IS : 1868 ) transparent or dyed to required colour or shade, with necessary screws etc. complete : 250x10 mm	each	9.00	69.78	627.98
51	Providing and fixing aluminium handles, ISI marked, anodised (anodic coating not less than grade AC 10 as per IS : 1868) transparent or dyed to required colour or shade, with necessary screws etc. complete : 125 mm	each	28.00	40.47	1133.19
52	Providing and fixing aluminium sliding door bolts, ISI marked anodised (anodic coating not less than grade AC 10 as per IS : 1868), transparent or dyed to required colour or shade, with nuts and screws etc. complete : 300x16	each	7.00	168.26	1177.82
53	Providing and fixing aluminium hanging floor door stopper, ISI marked, anodised (anodic coating not less than grade AC 10 as per IS : 1868) transparent or dyed to required colour and shade, with necessary screws etc. complete. Single rubber stopper	each	10.00	21.82	218.20

**PRICE BID**

**Construction of RCC Control Room buildings and other associated works for 5 MW floating Solar PV power plant for WBPDC, SAGARDIGHI at West Bengal”.**

Sl. No.	Description of Work	Unit	Qty.	ITEM RATE (Excluding GST)	Amount
54	Providing and fixing bright finished brass 100 mm mortice latch and lock, ISI marked, with six levers and a pair of anodised (anodic coating not less than grade AC 10 as per IS : 1868) aluminium lever handles of approved quality with necessary screws etc. complete.	each	6.00	492.74	2956.46
55	Providing and fixing aluminium extruded section body tubular type universal hydraulic door closer (having brand logo with IS : 3564, embossed on the body, door weight upto 36 kg to 80 kg and door width from 701 mm to 1000 mm), with double speed adjustment with necessary accessories and screws etc. complete.	each	10.00	307.61	3076.13
56	Providing and fixing 100mm brass locks (best make of approved quality) for aluminium doors including necessary cutting and making good etc. complete as per direction of Engineer In-Charge.	Each	5.00	284.33	1421.64
57	18 mm thick moulded cement mortar band in two coats under layer 12 mm thick with cement mortar 1:5 (1 cement : 5 coarse sand) top layer 6 mm thick with cement mortar 1:4 (1 cement : 4 fine sand).	cm per m	378.00	7.60	2874.01
58	Providing gola 75x75 mm in cement concrete 1:2:4 (1 cement : 2 coarse sand : 4 stone aggregate 10 mm and down gauge), including finishing with cement mortar 1:3 (1 cement : 3 fine sand) as per standard design : In 75x75 mm deep chase	meter	116.00	121.18	14056.42
59	Diluting and injecting chemical emulsion for POST- CONSTRUCTIONAL anti-termite treatment (including the cost of chemical emulsion) :Treatment of soil under existing floors using chemical emulsion @ one litre per hole, 300 mm apart including drilling 12 mm diameter holes and plugging with cement mortar 1 : 2 (1 cement : 2 Coarse sand) to match the existing floor: With Chlorpyrifos/Lindane E.C. 20% with 1% concentration	sqm	740.00	693.55	513230.26
60	Providing and fixing on wall face unplasticised Rigid PVC rain water pipes conforming to IS : 13592 Type A, including jointing with seal ring conforming to IS : 5382, leaving 10 mm gap for thermal expansion, (i) Single socketed pipes. 110 mm diameter	meter	54.00	187.19	10108.22
61	Providing and fixing on wall face unplasticised - PVC moulded fittings/accessories for unplasticised Rigid PVC rain water pipes conforming to IS : 13592 Type A, including jointing with seal ring conforming to IS : 5382, leaving 10 mm gap for thermal expansion. Shoe (Plain) 110 mm Shoe	each	10.00	77.62	776.16
62	Providing and laying in situ five course water proofing treatment with APP (Atactic Polypropylene) modified Polymeric memberane over roof consisting of first coat of bitumen primer @ 0.40Kg per sqm, 2nd & 4th courses of bonding material @ 1.20 kg/sqm, which shall consist of blown type bitumen of grade 85/25 conforming to IS : 702, 3rd layer of roofing membrane APP modified Polymeric membrane 2.0 mm thick of 3.00 Kg/ sqm weight consisting of five layers prefabricated with centre core as 100 micron HMHDPE film sandwiched on both sides with polymeric mix and the polymeric mix is protected on both side with 20 micron HMHDPE film. 5th, the top most layer shall be finished with brick tiles of class designation 10 grouted with cement mortar 1:3 (1 cement : 3 fine sand) mixed with 2% integral water proofing compound by weight of cement over a 12 mm layer of cement mortar 1:3 (1 cement : 3 fine sand) and finished neat (item of laying brick tiles shall be paid for separately).	sqm	709.00	254.63	180531.25
63	Providing and laying brick tiles over mumty roofs, grouted with cement mortar 1:3 (1 cement : 3 fine sand) mixed with 2% of integral water proofing compound by weight of cement, over 12 mm layer of cement mortar 1:3 (1 cement : 3 fine sand) and finished neat: With common burnt clay F.P.S. (non modular) brick tiles of class designation 10	sqm	1341.00	337.95	453186.12
64	Steel reinforcement for R.C.C. work including straightening, cutting, bending, placing in position and binding all complete upto all level. Thermo-Mechanically Treated bars of grade Fe-500D or more.	kg	31944.00	44.83	1431960.08
65	Making plinth protection 75mm thick of cement concrete 1:3:6 (1 cement : 3 coarse sand : 6 graded stone aggregate 20 mm nominal size) over 75mm thick bed of dry brick ballast 40 mm nominal size, well rammed and consolidated and grouted with fine sand, including necessary excavation, levelling & dressing & finishing the top smooth.	sqm	118.00	356.68	42087.91
66	Structural steel work riveted, bolted or welded in built up sections, trusses and framed work, including cutting, hoisting, fixing in position and applying a priming coat of approved steel primer all complete.	kg	3776.00	53.54	202164.02
67	Steel work welded in built up sections/ framed work, including cutting, hoisting, fixing in position and applying a priming coat of approved steel primer using structural steel etc. as required. In stringers, treads, landings etc. of stair cases, including use of chequered plate wherever required, all complete	kg	2999.00	52.11	156288.69

**PRICE BID**

**Construction of RCC Control Room buildings and other associated works for 5 MW floating Solar PV power plant for WBPDC, SAGARDIGHI at West Bengal”.**

Sl. No.	Description of Work	Unit	Qty.	ITEM RATE (Excluding GST)	Amount
68	Painting with synthetic enamel paint of approved brand and manufacture to give an even shade : Two or more coats on new work	sqm	200.00	62.09	12418.56
69	Random rubble masonry with hard stone in foundation and plinth including levelling up with cement concrete 1:6:12 (1 cement : 6 coarse sand : 12 graded stone aggregate 20 mm nominal size) upto plinth level with : Cement mortar 1:6 (1 cement : 6 coarse sand)	cum	5.00	3140.95	15704.77
70	Providing and laying damp-proof course 40mm thick with cement concrete 1:2:4 (1 cement : 2 coarse sand (zone-III): 4 graded stone aggregate 12.5mm nominal size) Extra for providing and mixing water proofing material in cement concrete work in doses by weight of cement as per manufacturer's specification. Providing & applying a coat of residual petroleum bitumen of grade of VG-10 of approved quality using 1.7kg per square metre on damp proof course after cleaning the surface with brushes and finally with a piece of cloth lightly soaked in kerosene oil.	sqm	26.00	395.09	10272.32
71	Providing and fixing PVC pipes for cable entry conforming to IS 4985 of SWR quality 4 Kg & 6 Kg / Sq cm, pressure. The rate shall include cost of all fittings like plain elbow, plain tee, plain Y, 4 way tee and all required necessary specials etc., complete. jointing with rubber ring and solvent joints providing MS brackets grouted in the wall and fasteners cutting and making good the walls and floors (pipes running expose in sanitary ducts) supreme or prince quality pipes. <b>150mm</b> dia complete as per direction of Engineer In-Charge.	RM	50.00	117.91	5895.45
72	Providing and fixing white vitreous china pedestal type water closet (European type W.C. pan) with seat and lid, 10 litre low level white P.V.C. flushing cistern, including flush pipe, with manually controlled device (handle lever), conforming to IS : 7231, with all fittings and fixtures complete, including cutting and making good the walls and floors wherever required :W.C. pan with ISI marked white solid plastic seat and 390 mm high with lid complete as per direction of Engineer In-Charge.	Each	2.00	2707.61	5415.22
73	Providing and fixing approved quality paper holder fix on wall with rawl plugs all materials labours etc., all complete as directed by the Engineer-in-charge.C.P. brass	Each	2.00	305.20	610.39
74	Providing and fixing white vitreous china flat back or wall corner type lipped front urinal basin of 430x260x350 mm and 340x410x265 mm sizes respectively with automatic flushing cistern with standard flush pipe and C.P. brass spreaders with brass unions and G.I clamps complete, including painting of fittings and brackets, cutting and making good the walls and floors wherever required :One urinal basin with 5 litre white P.V.C. automatic flushing cistern complete as per direction of Engineer In-Charge.	Each	2.00	2767.37	5534.73
75	Providing and fixing wash basin with C.I. brackets, 15 mm C.P. brass pillar taps, 32 mm C.P. brass waste of standard pattern, including painting of fittings and brackets, cutting and making good the walls wherever require: White Vitreous China Wash basin size 550x400 mm with a pair of 15 mm C.P. brass pillar taps	Each	2.00	1659.48	3318.96
76	Providing and fixing 600x450 mm beveled edge mirror of superior glass (of approved quality) complete with 6 mm thick hard board ground fixed to wooden cleats with C.P. brass screws hard board backing complete as per direction of Engineer In-Charge.and washers complete.	Each	2.00	647.82	1295.63
77	Providing and fixing PTMT TOWEL RAIL complete with brackets fixed to wooden cleats with CP brass screws with concealed fittings arrangement of approved quality and colour. brass towel rail 600mm long and 20 dia mm with C.P. brass brackets complete as per direction of Engineer In-Charge.	Each	4.00	334.78	1339.11
78	Providing and fixing approved quality liquid soap dispenser and holder fix on wall with rawl plugs all materials labours etc., all complete as directed by the Engineer-in-charge.	Each	2.00	73.69	147.38
79	Providing and fixing approved brands of three layered Sintex Water tank-PVC water tanks including,lifting, positioning and cost of all labours, materials, fittings etc.complete as per direction of Engineer In-Charge.-(2000L each)	ltrs	1000.00	7.37	7371.00
80	Providing and fixing <b>PVC, soil waste and vent pipes</b> conforming to IS 4985 of SWR quality 4 Kg & 6 Kg / Sq cm, pressure. The rate shall include cost of all fittings like plain elbow, plain tee, plain Y, 4 way tee and all required necessary specials etc., complete. jointing with rubber ring and solvent joints providing MS brackets grouted in the wall and fasteners cutting and making good the walls and floors (pipes running expose in sanitary ducts) supreme or prince quality pipes. <b>75 mm</b> dia complete as per direction of Engineer In-Charge.	RM	10.00	73.69	736.92

**PRICE BID**

**Construction of RCC Control Room buildings and other associated works for 5 MW floating Solar PV power plant for WBPDC, SAGARDIGHI at West Bengal”.**

Sl. No.	Description of Work	Unit	Qty.	ITEM RATE (Excluding GST)	Amount
81	Providing and fixing <b>PVC, soil waste and vent pipes</b> conforming to IS 4985 of SWR quality 4 Kg & 6 Kg / Sq cm, pressure. The rate shall include cost of all fittings like plain elbow, plain tee, plain Y, 4 way tee and all required necessary specials etc., complete. jointing with rubber ring and solvent joints providing MS brackets grouted in the wall and fasteners cutting and making good the walls and floors (pipes running expose in sanitary ducts) supreme or prince quality pipes. <b>110 mm</b> dia complete as per direction of Engineer In-Charge.	RM	60.00	95.81	5748.30
82	Providing and fixing <b>PVC, soil waste and vent pipes</b> conforming to IS 4985 of SWR quality 4 Kg & 6 Kg / Sq cm, pressure. The rate shall include cost of all fittings like plain elbow, plain tee, plain Y, 4 way tee and all required necessary specials etc., complete. jointing with rubber ring and solvent joints providing MS brackets grouted in the wall and fasteners cutting and making good the walls and floors (pipes running expose in sanitary ducts) supreme or prince quality pipes. <b>150 mm</b> dia complete as per direction of Engineer In-Charge.	RM	10.00	117.91	1179.09
83	Providing and fixing <b>High-density polyethylene (HDPE) pipes</b> , including all HDPE pipes & fittings, trenching, refilling & testing of joints complete as per direction of Engineer in Charge. <b>75 mm</b> nominal inner dia Pipes.	meter	5.00	951.23	4756.16
84	Providing and fixing <b>High-density polyethylene (HDPE) pipes</b> , including all HDPE pipes & fittings, trenching, refilling & testing of joints complete as per direction of Engineer in Charge. <b>100 mm</b> nominal inner dia Pipes.	meter	5.00	1281.54	6407.68
85	Providing and fixing <b>High-density polyethylene (HDPE) pipes</b> , including all HDPE pipes & fittings, trenching, refilling & testing of joints complete as per direction of Engineer in Charge. <b>150 mm</b> nominal inner dia Pipes.	meter	5.00	1907.73	9538.65
86	Providing & fixing 100 mm PVC for gully, floor or nahani trap at all heights and levels complete as per direction of Engineer In-Charge.	Each	6.00	515.87	3095.23
87	Providing and fixing gun metal gate valve with C.I. wheel of approved quality (screwed end) :25 mm nominal bore complete as per direction of Engineer In-Charge.	Each	6.00	339.13	2034.81
88	Providing and fixing gun metal gate valve with C.I. wheel of approved quality (screwed end) :50 mm nominal bore complete as per direction of Engineer In-Charge.	Each	2.00	593.92	1187.84
89	Providing and fixing brass stop cock of approved design, quality and make 15mm NB complete as per direction of Engineer In-Charge.	Each	5.00	206.00	1030.00
90	Providing and fixing brass stop cock of approved design, quality and make 20mm NB complete as per direction of Engineer In-Charge.	Each	5.00	222.08	1110.38
91	Providing and fixing <b>Chlorinated Polyvinyl Chloride (CPVC) pipes</b> , having thermal stability for hot & cold water supply, including all CPVC plain & brass threaded fittings, i/c fixing the pipe with clamps at 1.00 m spacing. This includes jointing of pipes & fittings with one step CPVC solvent cement and the cost of cutting chases and making good the same including testing of joints complete as per direction of Engineer in Charge. Concealed work, including cutting chases and making good the walls etc. <b>15 mm</b> nominal outer dia Pipes	meter	10.00	194.99	1949.90
92	Providing and fixing <b>Chlorinated Polyvinyl Chloride (CPVC) pipes</b> , having thermal stability for hot & cold water supply, including all CPVC plain & brass threaded fittings, i/c fixing the pipe with clamps at 1.00 m spacing. This includes jointing of pipes & fittings with one step CPVC solvent cement and the cost of cutting chases and making good the same including testing of joints complete as per direction of Engineer in Charge. Concealed work, including cutting chases and making good the walls etc. <b>20 mm</b> nominal outer dia Pipes	meter	30.00	225.60	6768.04
93	Providing and fixing <b>Chlorinated Polyvinyl Chloride (CPVC) pipes</b> , having thermal stability for hot & cold water supply, including all CPVC plain & brass threaded fittings, i/c fixing the pipe with clamps at 1.00 m spacing. This includes jointing of pipes & fittings with one step CPVC solvent cement and the cost of cutting chases and making good the same including testing of joints complete as per direction of Engineer in Charge. Concealed work, including cutting chases and making good the walls etc. <b>25 mm</b> nominal outer dia Pipes	meter	30.00	264.21	7926.34
94	Providing and fixing <b>unplasticized polyvinyl chloride (uPVC) pipes</b> , including all uPVC plain & brass threaded fittings, including fixing the pipe with clamps at 1.00 m spacing. This includes jointing of pipes & fittings with one step uPVC solvent cement and testing of joints complete as per direction of Engineer in Charge. Internal work - Exposed on wall. <b>15 mm</b> nominal outer dia Pipes.	meter	10.00	113.22	1132.16

**PRICE BID**

**Construction of RCC Control Room buildings and other associated works for 5 MW floating Solar PV power plant for WBPDC, SAGARDIGHI at West Bengal”.**

Sl. No.	Description of Work	Unit	Qty.	ITEM RATE (Excluding GST)	Amount
95	Providing and fixing <b>unplasticized polyvinyl chloride (uPVC) pipes</b> , including all uPVC plain & brass threaded fittings, including fixing the pipe with clamps at 1.00 m spacing. This includes jointing of pipes & fittings with one step uPVC solvent cement and testing of joints complete as per direction of Engineer in Charge. Internal work - Exposed on wall. <b>20 mm</b> nominal outer dia Pipes.	meter	30.00	142.52	4275.61
96	Providing and fixing <b>unplasticized polyvinyl chloride (uPVC) pipes</b> , including all uPVC plain & brass threaded fittings, including fixing the pipe with clamps at 1.00 m spacing. This includes jointing of pipes & fittings with one step uPVC solvent cement and testing of joints complete as per direction of Engineer in Charge. Internal work - Exposed on wall. <b>25 mm</b> nominal outer dia Pipes.	meter	30.00	171.23	5136.91
97	Providing and fixing <b>unplasticized polyvinyl chloride (uPVC) pipes</b> , including all uPVC plain & brass threaded fittings, including fixing the pipe with clamps at 1.00 m spacing. This includes jointing of pipes & fittings with one step uPVC solvent cement and testing of joints complete as per direction of Engineer in Charge. Internal work - Exposed on wall. <b>50 mm</b> nominal outer dia Pipes.	meter	10.00	434.45	4344.52
98	Providing and fixing G.I. Pipes complete with G.I. fittings and clamps, i/c making good the walls etc. concealed pipe, including painting with anti corrosive bitumastic paint, cutting chases and making good the wall 15 mm dia nominal bore	meter	10.00	226.27	2262.74
99	Providing and fixing G.I. Pipes complete with G.I. fittings and clamps, i/c making good the walls etc. concealed pipe, including painting with anti corrosive bitumastic paint, cutting chases and making good the wall :20 mm dia nominal bore	meter	30.00	250.43	7512.91
100	Providing and fixing G.I. pipes complete with G.I. fittings and clamps, i/c cutting and making good the walls etc. Internal work - Exposed on wall 15 mm dia nominal bore	meter	10.00	147.63	1476.29
101	Providing and fixing G.I. pipes complete with G.I. fittings and clamps, i/c cutting and making good the walls etc. Internal work - Exposed on wall 20 mm dia nominal bore	meter	30.00	177.53	5325.80
102	Providing and fixing G.I. pipes complete with G.I. fittings including trenching and refilling etc.25 mm dia nominal bore	meter	30.00	163.03	4891.00
103	Providing and fixing G.I. pipes complete with G.I. fittings including trenching and refilling etc.50 mm dia nominal bore	meter	10.00	271.42	2714.18
104	Providing and fixing brass bib cock of approved quality: 15 mm nominal bore complete as per direction of Engineer In-Charge.	Each	8.00	206.00	1647.99
105	Providing and fixing brass bib cock of approved quality 20 mm nominal bore complete as per direction of Engineer In-Charge.	Each	8.00	222.08	1776.61
106	Providing and fixing brass stop cock of approved design, quality and make 15mm NB complete as per direction of Engineer In-Charge.	Each	8.00	206.00	1647.99
107	Providing and fixing brass stop cock of approved design, quality and make 20mm NB complete as per direction of Engineer In-Charge.	Each	8.00	222.08	1776.61
108	Providing and fixing vista make vertical blind of approved color and brand cost is including of supply of materials, fixing, labour charges, transportation all leads, lifts, taxes etc. complete at all height and levels complete as per direction of Engineer In-Charge.	Sqm	23.00	626.42	14407.61
<b>TOTAL AMOUNT: (A) Civil works</b>					<b>Rs. 8,893,013.19</b>

PRICE BID					
Construction of RCC Control Room buildings and other associated works for 5 MW floating Solar PV power plant for WBPDC, SAGARDIGHI at West Bengal".					
Sl. No.	Description of Work	Unit	Qty.	ITEM RATE (Excluding GST)	Amount
<b>(B) Electrical works</b>					
SL no:	Description of Work	Unit	Qty.	ITEM RATE (Excluding GST)	Amount
109	LED indoor luminaire, industrial grade with diffuser and heat sink, minimum 3-star BEE rating, 30W, 240V, Philips/ Syska/ Havells/ Wipro/ Bajaj/ Crompton make as per LM79-08 & LM80-15 standards as approved by SCCL/BHEL	Nos	50.00	3316.33	165816.45
110	LED indoor luminaire, industrial grade with diffuser and heat sink, minimum 3-star BEE rating, 10W, 240V, Philips/ Syska/ Havells/ Wipro/ Bajaj/ Crompton make as per LM79-08 & LM80-15 standards as approved by SCCL/BHEL	Nos	20.00	1105.44	22108.86
111	LED bulkhead luminaire around the building (on the outer walls), 9W, 240V, minimum 3-star BEE rating, Philips/ Syska/ Havells/ Wipro/ Bajaj/ Crompton make as per LM79-08 & LM80-15 standards as approved by SCCL/BHEL	Nos	30.00	147.39	4421.79
112	Ceiling fan 1200 mm sweep 5 star type Khaitan/ Usha/ Bajaj/ Crompton/ Havells make as approved by SCCL/BHEL	Nos	10.00	2579.37	25793.73
113	Fan regulator Modular type of reputed make as approved by SCCL/BHEL	Nos	10.00	184.24	1842.39
114	6A modular type switch of reputed make as approved by SCCL/BHEL	Nos	150.00	110.55	16582.05
115	6A, 1ph, 5 pin, switched socket outlet Modular type of reputed make as approved by SCCL/BHEL	Nos	10.00	110.55	1105.47
116	16A, 1ph, 5 pin, switched socket outlet Module type of reputed make as approved by SCCL/BHEL	Nos	20.00	221.09	4421.70
117	3x6A, 1ph, 5 (2-3) pin socket outlet controlled by one 16A switch of reputed make as approved by SCCL/BHEL	Nos	10.00	368.48	3684.78
118	25A, 1ph, 5 pin, industrial socket with MCB enclosure of reputed make as approved by SCCL/BHEL	Nos	10.00	257.94	2579.40
119	63A, 3ph, 415V, industrial socket with MCB enclosure of reputed make as approved by SCCL/BHEL	Nos	2.00	361.85	723.69
120	Exhaust fan 450mm of reputed make as approved by SCCL/BHEL	Nos	12.00	7001.15	84013.74
121	Power distribution board of reputed make as approved by SCCL/BHEL	Nos	2.00	5527.22	11054.45
122	Cables, cable conduits, cable accessories for the above, all conduits (Embedded in wall or floor) shall be 1" pvc pipe (dia) of reputed make as approved by SCCL/BHEL	Mtr	500.00	29.48	14742.00
123	4CX25 Sq mm Cu Cable of reputed make as approved by SCCL/BHEL	Mtr	50.00	331.63	16581.60
<b>TOTAL AMOUNT: (B) Electrical works</b>					<b>Rs. 375,472.10</b>
Activities	<b>Summary of the activities</b>				
A	Civil works				Rs. 8,893,013.19
B	Electrical works				Rs. 375,472.10
Total value of the works (rounded off)					<b>Rs. 9,268,485.29</b>
<b>QUOTE PERCENTAGE (%) ABOVE/BELOW (+/-) (OR) AT PAR TO TOTAL AMOUNT</b>					
<b>QUOTED PERCENTAGE (%) IN WORDS ABOVE/BELOW (OR) AT PAR TO TOTAL AMOUNT</b>					
<b>Plus applicable GST</b>					
<b>NOTE:</b>					
1. CONTRACTOR SHOULD QUOTE PERCENTAGE (%) ABOVE/BELOW (OR) AT PAR TO TOTAL AMOUNT					
2. QUOTED PERCENTAGE (%) IS APPLICABLE ON ALL ITEM RATES UNIFORMLY.					