

Rev 01  
1st Jun  
2012

# NOTICE INVITING TENDER

(Document No PS:MSX:NIT)

Bharat Heavy Electricals Limited



=====

**NOTICE INVITING E-TENDER (NIT)**

**BIDDER TO SUBMIT OFFERS ON PORTAL <https://bheleps.buyjunction.in>**

=====

To

Dear Sir/Madam

**Sub : NOTICE INVITING E-TENDER**

Sealed offers in two part bid system are invited from reputed & experienced bidders (meeting PRE QUALIFICATION CRITERIA as mentioned in Annexure-I) for the subject job by the undersigned on the behalf of BHARAT HEAVY ELECTRICALS LIMITED as per the tender document. Following points relevant to the tender may please be noted and complied with.

**1. Salient Features of NIT**

SL NO	ISSUE	DESCRIPTION	
i	<b>TENDER NUMBER</b>	<b>BHEL/ NR/SCT/PANKI/GEOTECH INV/1078</b>	
ii	<b>Broad Scope of job</b>	<b>GEOTECHNICAL INVESTIGATION AND TOPOGRAPHICAL SURVEY FOR 1X660 MW PANKI THERMAL POWER STATION, KANPUR, U.P.</b>	
iii	<b>DETAILS OF TENDER DOCUMENT</b>		
a	Volume-IA	<i>Technical Conditions of Contract (TCC) consisting of Scope of work, Technical Specification, Drawings, Procedures, Bill of Quantities, Terms of payment, etc</i>	<i>Applicable</i>
b	Volume-IB	<i>Special Conditions of Contract (SCC)</i>	<i>Applicable</i>
c	Volume-IC	<i>General Conditions of Contract (GCC)</i>	<i>Applicable</i>
d	Volume-ID	<i>Forms and Procedures</i>	<i>Applicable</i>
e	Volume-II	<i>Price Schedule (Absolute value).</i>	<i>Applicable</i>
iv	<b>Issue of Tender Documents</b>	<b>From BHEL website (<a href="http://www.bhel.com">www.bhel.com</a>) and <a href="https://bheleps.buyjunction.in">https://bheleps.buyjunction.in</a></b> Tender documents will be available at website till due date of submission	<i>Applicable</i>
v	<b>DUE DATE &amp; TIME OF OFFER SUBMISSION</b>	<b>Date : 22/12/2017 , Time : 1500 HRS</b> <b>Place : on <a href="https://bheleps.buyjunction.in">https://bheleps.buyjunction.in</a></b>	<i>Applicable</i>
vi	<b>OPENING OF TENDER</b>	<b>At due date / time</b> <b>Date : 22/12/2017 , Time :1530 HRS</b> Notes: (1) In case the due date of opening of tender becomes a non-working day, then the due date & time of offer submission and opening of tenders get extended to the next working day. (2) Bidder may depute representative to witness the opening of tender. <b>However it being an e-tender it shall be opened online</b>	<i>Applicable</i>
vii	<b>EMD AMOUNT</b>	<b>Rs. 1,39,900/-</b>	<i>Applicable</i>
viii	<b>COST OF TENDER</b>	<b>Rs 2,000/-</b>	<i>Applicable</i>

ix	<b>LAST DATE FOR SEEKING CLARIFICATION</b>	<p><b>Five days before bid submission due date.</b>  Along with soft version also, addressing to contact address given below</p> <p>1) Name: SUSMITA BASU  Designation:SR. DGM  Deptt: SCT  Address: BHEL-PSNR, PLOT NO. 25, SECTOR – 16A, NOIDA - 201301  Phone: (Landline/Mobile) 0120-2416262  Email : susmitabasu@bhel.in</p> <p>2) Name: CHITTARANJAN SWAIN  Designation: DY. MANAGER  Deptt: SCT  Address: BHEL-PSNR, PLOT NO. 25, SECTOR – 16A, NOIDA - 201301  Phone: (Landline/Mobile) 0120 - 2416500  Email : cs@bhel.in</p>	Applicable
x	<b>SCHEDULE OF Pre Bid Discussion (PBD)</b>		Not applicable.
xi	<b>INTEGRITY PACT &amp; DETAILS OF INDEPENDENT EXTERNAL MONITOR (IEM)</b>		Not applicable
xii	<b>Latest updates</b>	<p>Latest updates on the important dates, Amendments, Correspondences, Corrigenda, Clarifications, Changes, Errata, Modifications, Revisions, etc to Tender Specifications will be hosted in BHEL webpage (www.bhel.com --&gt;Tender Notifications →View Corrigendums) &amp; portal <a href="https://bheleps.buyjunction.in">https://bheleps.buyjunction.in</a> <b>and not in the newspapers</b>. Bidders to keep themselves updated with all such information</p>	
xiii	<b>Tender submission</b>	on portal <a href="https://bheleps.buyjunction.in">https://bheleps.buyjunction.in</a>	

2. The offer shall be submitted as per the instructions of tender document and as detailed in this NIT. Bidders to note specifically that all pages of tender document, including these NIT pages of this particular tender together with subsequent correspondences shall be submitted by them, **Rates/Price including discounts/rebates, if any, mentioned anywhere/in any form in the techno-commercial offer other than the Price Bid, shall not be entertained.**
3. Unless specifically stated otherwise, bidder shall remit cost of tender and courier charges if applicable, in the form of Demand Draft drawn in favour of Bharat Heavy Electricals Ltd, payable at Power Sector Regional HQ at Noida issuing the Tender, along with techno-commercial offer. Bidder may also choose to deposit the Tender document cost by cash at the Cash Office as stated above against sl no iv of 1, on any working day; and in such case copy of Cash receipt is to be enclosed with the Techno Commercial offer. Sale of tender Documents shall not take place on National Holidays, holidays declared by Central or State Governments and BHEL PS HQ at Noida, Sundays and second/ last Saturdays.

**As this tender is an E-Tender and no paper bids will be accepted therefore the scanned copy of the Demand Draft or the Cash Receipt issued by BHEL PSNR should be uploaded in the E procurement portal.** Hard Copy of the demand draft should reach BHEL PSNR HQ Noida before the due date and time of bid submission. BHEL shall not be responsible for postal or any other delays in this regard.

4. Unless specifically stated otherwise, bidder shall deposit EMD through Cash Deposit (as permissible under the extant Income Tax Act) (before tender opening), Electronic Fund Transfer credited in BHEL account (before Tender Opening) or Banker's Cheque/ Demand Draft/ Pay Order in favour of Bharat Heavy Electricals Ltd, payable at Noida (along with offer).

'One Time EMD' will not be considered for this tender. All the bidders who have 'One Time EMD' with BHEL and want to participate in this tender, would also submit the requisite amount of EMD as mentioned in Clause No. 1, Salient Features of NIT, Sl. No. (vii) above.

However, the One Time EMD can be adjusted against the EMD applicable against this tender on specific request of bidder.

For Electronic Fund Transfer the details are as below-:

a) **Name of the Beneficiary** -: Bharat Heavy Electricals Limited

b) **Bank Particulars**

i).	Bank Name :-	STATE BANK OF INDIA
ii).	Bank Telephone No.(with STD code)-:	011-23352180
iii).	Branch Address-:	CAG BRANCH, NEW DELHI
iv).	Bank Fax No. (with STD code) -:	011-23353101
v).	Branch Code -:	SBIN0009996
vi).	9 Digit MICR Code of the Bank Branch -:	110002201
vii).	Bank Account Number -:	10813608647
viii).	Bank Account Type -:	CASH CREDIT
ix).	11 Digit IFSC Code of Beneficiary Branch-:	SBIN0009996

(Note-: In case of E-Tenders, no paper bids shall be accepted, therefore, the scanned copy of the Banker's Cheque/ Demand Draft/ Pay Order/ Details of payment made through Electronic Fund Transfer should be uploaded in the E-Procurement Portal and hard copy of the same should reach BHEL-PSNR HQ Noida before the due date and time of bid submission. BHEL shall not be responsible for postal or any other delays in this regard.)

For other details please refer General Conditions of Contract.

5. **Procedure for Submission of Tenders**: This is an E-tender floated online through our E-Procurement Site <https://bheleps.buyjunction.in>. The bidder should respond by submitting their offer online only in our e-Procurement platform at <https://bheleps.buyjunction.in>. Offers are invited in two-parts only.

#### **Documents Comprising the e-Tender**

The tender shall be submitted online ONLY EXCEPT TENDER FEE & EMD (in physical form) as mentioned below:

##### **a. Technical Tender (UN priced Tender)**

All Technical details (eg. Eligibility Criteria requested (as mentioned below)) should be attached in e-tendering module, failing which the tender stands invalid & may be REJECTED. Bidders shall furnish the following information along with technical tender (preferably in pdf format):

- Tender Cost and Earnest money Deposit (EMD) furnished in accordance with NIT Clause 3.0 & 4.0. Alternatively, documentary evidence for claiming exemption as per clause 28 of NIT
- Technical Bid (without indicating any prices).

##### **b. Price Bid:**

- Prices are to be quoted in the attached Price Bid format online on e-tender portal.
- The price should be quoted for the accounting unit indicated in the e-tender document.

- iii. Note: It is the responsibility of tenderer to go through the Tender document to ensure furnishing all required documents in addition to above, if any. Any deviation would result in REJECTION of tender and would not be considered at a later stage at any cost by BHEL.
- iv. A person signing (manually or digitally) the tender form or any documents forming part of the contract on behalf of another shall be deemed to warrantee that he has authority to bind such other persons and if, on enquiry, it appears that the persons so signing had no authority to do so, the purchaser may, without prejudice to other civil and criminal remedies, cancel the contract and hold the signatory liable for all cost and damages.
- v. A tender, which does not fulfil any of the above requirements and/or gives evasive information/reply against any such requirement, shall be liable to be ignored and rejected.
- vi. In case offer is sent through hard copy/fax/telex/cable/electronically in place of e-tender, same shall not be considered.

### **DO NOT'S**

Bidders are requested NOT to submit the hard copy of the Bid. In case offer is sent through hard copy/fax/telex/cable/electronically in place of e-tender, the same shall not be considered. **Also, uploading of the price bid in prequalification bid or technical bid may RESULT IN REJECTION of the tender.**

### **Digital Signing of e-Tender**

Tenders shall be uploaded with all relevant PDF/zip format. The relevant tender documents should be uploaded by an authorized person having Class 3- SHA2- 2048 BIT- SIGNING & ENCRYPTION digital signature certificate (DSC).

#### **The Requirement:**

1. A PC with Internet connectivity &
2. DSC (Digital Signature Certificate)( **Class 3- SHA2- 2048 BIT- SIGNING & ENCRYPTION**)

BHEL has finalized the e-procurement service Provider-:

#### **M/s M Junction services Limited, Kolkata**

Godrej Water Side, 3rd Floor, Tower-1, Plot-V, Block - DP  
Sector - V, Salt Lake, Kolkata-700091, West Bengal, INDIA

The contact details of the service provider are given below:

1. **First level:**
  - o MJ Helpdesk : 033-66011717, eps.customercare@mjunction.in
2. **Second Level:**
  - o Bhaskar Chakraborty: 8584008205, bhaskar.chakraborty@mjunction.in, eps.customercare@mjunction.in
  - o Santosh Kumar: 9717149600, santosh.kumar@mjunction.in
3. **Third Level:**
  - o Rimi Ghosh: 9650044156, rimi.ghosh@mjunction.in
  1. Customer care Help Desk of M/s MJUNCTION SERVICES LIMITED, Kolkata:  
Tel ~ 033 - 66011717 (From 9.30 am to 5.30 pm),  
Mob - 91633 48283 - 86/ 85840 08116 (From 5.30 pm to 8.30 pm)  
HELPDESK email: eps.customercare@mjunction.in,  
The process of utilizing e-procurement necessitates usage of **DSC (Digital Signature Certificate) (Class 3- SHA2- 2048 BIT- SIGNING & ENCRYPTION)** and you are requested to procure the same immediately, if not presently available with you. Please note that only with DSC, you will be able to login the e-procurement secured site and take part in the tendering process.
  2. The contact details of the DSC Certifying Authority as given below

1	<b>GNFC</b>	<a href="http://www.ncodesolutions.com">www.ncodesolutions.com</a>
2	<b>e-Mudhra</b>	<a href="http://www.e-Mudhra.com">http://www.e-Mudhra.com</a>
3	<b>Safescrypt</b>	<a href="http://www.safescrypt.com">www.safescrypt.com</a>

Vendors are also requested to go through seller manual available on [www.bheleps.buyjunction.in](http://www.bheleps.buyjunction.in)

6. **Not Used**

7. Deviation with respect to tender clauses and additional clauses/suggestions in Techno-commercial bid / Price bid shall NOT be considered by BHEL. Bidders are requested to positively comply with the same.

8. BHEL reserves the right to accept or reject any or all Offers without assigning any reasons thereof. BHEL also reserves the right to cancel the Tender wholly or partly without assigning any reason thereof. Also BHEL shall not entertain any correspondence from bidders in this matter (except for the refund of EMD).

9. **Assessment of Capacity of Bidders:**

**Bidder's capacity for executing the job under tender shall be assessed 'LOAD' wise and 'PERFORMANCE' wise as per the following:**

- I. **LOAD:** Load takes into consideration **ALL** the contracts of the Bidder under execution with BHEL Regions, irrespective of whether they are similar to the tendered scope or not. The cut off month for reckoning 'Load' shall be the 3<sup>rd</sup> Month preceding the month corresponding to the 'latest date of bid submission', in the following manner -

(**Note:** For example, if latest bid submission is in Jan 2017, then the 'load' shall be calculated up to and inclusive of Oct 2016)

Total number of Packages in hand = Load (P)

Where 'P' is the sum of all unit wise identified packages (refer table-1) under execution with BHEL Regions as on the cut off month defined above, including packages yet to be commenced, excepting packages which are on Long Hold.

- II. **PERFORMANCE:** Here 'Monthly Performance' of the bidder for all the packages (under execution/ executed during the 'Period of Assessment' in all Power Sector Regions of BHEL) **SIMILAR** to the packages covered under the tendered scope, excepting packages not commenced shall be taken into consideration. The 'Period of Assessment' shall be 6 months preceding and including the cut off month. The cut off month for reckoning 'Period of Assessment' shall be the 3<sup>rd</sup> Month preceding the month corresponding to 'latest date of bid submission', in the following manner:

(**Note:** For example, if 'latest date of bid submission' is in Jan 2017, then the 'performance' shall be assessed for a 6 months' period up to and inclusive of Oct 2016 (i.e. from May 2016 to Oct 2016), for all the unit wise identified packages (refer Table -1))

- i). **Calculation of Overall 'Performance Rating' for 'Similar Package/Packages' for the tendered scope under execution at Power Sector Regions for the 'Period of Assessment':**

This shall be obtained by summing up the 'Monthly Performance Evaluation' scores obtained by the bidder in all Regions for all the similar Package/packages', divided by the total number of Package months for which evaluation should have been done, as per procedure below:

- a) P<sub>1</sub>, P<sub>2</sub>, P<sub>3</sub>, P<sub>4</sub>, P<sub>5</sub>, .... P<sub>N</sub> etc. be the packages (under execution/ executed during the 'Period of Assessment' in all Regions of BHEL) **SIMILAR** to the packages covered under the tendered scope, excepting packages not commenced. Total number of similar packages for all Regions = P<sub>T</sub> (i.e. P<sub>T</sub> = P<sub>1</sub>+P<sub>2</sub>+ P<sub>3</sub>+P<sub>4</sub> +...P<sub>N</sub>)
- b) Number of Months 'T<sub>1</sub>' for which 'Monthly Performance Evaluation' as per relevant formats, should have been done in the 'Period of Assessment' for the corresponding similar package P<sub>1</sub>. Similarly

T<sub>2</sub> for package P<sub>2</sub>, T<sub>3</sub> for package P<sub>3</sub>, etc. for the tendered scope. Now calculate cumulative total months 'T<sub>T</sub>' for total similar Packages 'P<sub>T</sub>' for all Regions (i.e. T<sub>T</sub> = T<sub>1</sub> + T<sub>2</sub> + T<sub>3</sub> + T<sub>4</sub> + .. T<sub>N</sub>)

- c) Sum 'S<sub>1</sub>' of 'Monthly Performance Evaluation' Scores (S<sub>1-1</sub>, S<sub>1-2</sub>, S<sub>1-3</sub>, S<sub>1-4</sub>, S<sub>1-5</sub>... S<sub>1-T1</sub>) for similar package P<sub>1</sub>, for the 'period of assessment' 'T<sub>1</sub>' (i.e. S<sub>1</sub> = S<sub>1-1</sub>+ S<sub>1-2</sub>+ S<sub>1-3</sub>+ S<sub>1-4</sub>+ S<sub>1-5</sub>+...S<sub>1-T1</sub>). Similarly, S<sub>2</sub> for package P<sub>2</sub> for period T<sub>2</sub>, S<sub>3</sub> for package P<sub>3</sub> for period T<sub>3</sub> etc. for the tendered scope for all Regions. Now calculate cumulative sum 'S<sub>T</sub>' of 'Monthly Performance Evaluation' Scores for total similar Packages 'P<sub>T</sub>' for all Regions (i.e. 'S<sub>T</sub>'= S<sub>1</sub>+ S<sub>2</sub>+ S<sub>3</sub>+ S<sub>4</sub>+ S<sub>5</sub>+.... S<sub>N</sub>.)
- d) **Overall Performance Rating 'R<sub>BHEL</sub>' for the Similar Package/Packages** (under execution/ executed during the 'Period of Assessment') in all the Power Sector Regions of BHEL

$$= \frac{\text{Aggregate of Performance scores for all similar packages in all the Regions}}{\text{Aggregate of months for each of the similar packages for which performance should have been evaluated in all the Regions}}$$

$$= \frac{S_T}{T_T}$$

- e) **Bidders to note that the risk of non-evaluation or non-availability of the 'Monthly Performance Evaluation' reports as per relevant formats is to be borne by the Bidder.**

f) **Table showing methodology for calculating 'a', 'b' and 'c' above**

Sl. No.	Item Description	Details for all Regions							Total
(i)	(ii)	(iii)	(iv)	(v)	(vi)	(vii)	(viii)	(ix)	(x)
1	Similar Packages for all Regions → (under execution/ executed during period of assessment)	P <sub>1</sub>	P <sub>2</sub>	P <sub>3</sub>	P <sub>4</sub>	P <sub>5</sub>	...	P <sub>N</sub>	Total No. of similar packages for all Regions = P <sub>T</sub> i.e. Sum (Σ) of columns (iii) to (ix)
2	Number of Months for which 'Monthly Performance Evaluation' as per relevant formats should have been done in the 'period of assessment' for corresponding Similar Packages ( as in row 1)	T <sub>1</sub>	T <sub>2</sub>	T <sub>3</sub>	T <sub>4</sub>	T <sub>5</sub>	...	T <sub>N</sub>	Sum (Σ) of columns (iii) to (ix)  = T <sub>T</sub>
3	Monthly performance scores for the corresponding period (as in Row 2)	S <sub>1-1</sub> , S <sub>1-2</sub> , S <sub>1-3</sub> , S <sub>1-4</sub> , ... S <sub>1-T1</sub>	S <sub>2-1</sub> , S <sub>2-2</sub> , S <sub>2-3</sub> , S <sub>2-4</sub> , ... S <sub>2-T2</sub>	S <sub>3-1</sub> , S <sub>3-2</sub> , S <sub>3-3</sub> , S <sub>3-4</sub> , ... S <sub>3-T3</sub>	S <sub>4-1</sub> , S <sub>4-2</sub> , S <sub>4-3</sub> , S <sub>4-4</sub> , ... S <sub>4-T4</sub>	S <sub>5-1</sub> , S <sub>5-2</sub> , S <sub>5-3</sub> , S <sub>5-4</sub> , ... S <sub>5-T5</sub>	.. .. .. .. .. .. ..	S <sub>N-1</sub> , S <sub>N-2</sub> , S <sub>N-3</sub> , S <sub>N-4</sub> , ... S <sub>N-TN</sub>	-----
4	Sum of Monthly Performance scores of the corresponding Package for the corresponding period (as in row-3)	S <sub>1</sub>	S <sub>2</sub>	S <sub>3</sub>	S <sub>4</sub>	S <sub>5</sub>	...	S <sub>N</sub>	Sum (Σ) of columns (iii) to (ix) = S <sub>T</sub>

ii). Calculation of Overall 'Performance Rating' ( $R_{BHEL}$ ) in case at least 6 evaluation scores for 'similar Package/Packages' for the tendered scope ARE NOT AVAILABLE, during the 'Period of Assessment':

This shall be obtained by summing up the 'Monthly Performance Evaluation' scores obtained by the bidder in all Regions for ALL the packages, divided by the total number of Package months for which evaluation should have been done. ' $R_{BHEL}$ ' shall be calculated subject to availability of 'performance scores' for at least 6 'package months' in the order of precedence below:

- 'Period of Assessment' i.e. 6 months preceding and including the cut-off month
- 12 months preceding and including the cut-off month
- 24 months preceding and including the cut-off month
- 36 months preceding and including the cut-off month

In case,  $R_{BHEL}$  cannot be calculated as above, then Bidder shall be treated as 'NEW VENDOR'. Further eligibility and qualification of this bidder shall be as per definition of 'NEW VENDOR' described in 'Explanatory Notes'.

iii). Factor "L" assigned based on Overall Performance Rating ( $R_{BHEL}$ ) at Power Sector Regions:

Sl. no.	Overall Performance Rating ( $R_{BHEL}$ )	Corresponding value of 'L'
1	=60	NA
2	> 60 and $\leq$ 65	0.4
3	> 65 and $\leq$ 70	0.35
4	> 70 and $\leq$ 75	0.25
5	> 75 and < 80	0.2
6	$\geq$ 80	NA

III. 'Assessment of Capacity of Bidder':

'Assessment of Capacity of Bidder' is based on the Maximum number of packages for which a vendor is eligible, considering the performance scores of similar packages, as below:

Max number of packages  $P_{Max} = (R_{BHEL} - 60)$  divided by corresponding value of 'L', i.e.  $(R_{BHEL} - 60)/L$

Note:

- In case the value of  $P_{Max}$  results in a fraction, the value of  $P_{Max}$  is to be rounded off to next whole number
- For  $R_{BHEL} = 60$ ,  $P_{Max} = '1'$
- For  $R_{BHEL} \geq 80$ , there will be no upper limit on  $P_{Max}$

The Bidder shall be considered 'Qualified' as per 'Assessment of Capacity of Bidder' for the subject Tender if  $P \leq P_{Max}$   
(Where P is calculated as per clause 'i' above)

IV. Explanatory note:

- Similar package means Boiler or ESP or Piping or Turbine or Civil or Structure or Electrical or C&I etc. at the individual level irrespective of rating of Plant and irrespective of whether the subject tender is a single package or as part of combined/composite packages. Normally Boiler, ESP, Piping, Turbine, Electrical, C&I, Civil, Structure etc. is considered individual level of package. For example, in case the tendered scope is a Boiler Vertical Package comprising of Boiler, ESP and Power Cycle Piping (i.e. the 'identified packages as per Table-1 below), the 'PERFORMANCE' part against sl.no. II above, needs to be evaluated considering all the identified packages (i.e. Boiler, ESP and Power Cycle Piping) and finally the Bidder's capacity to execute the tendered scope is assessed in line with III above.
- Identified Packages (Unit wise)

**Table-1**

Civil	Electrical and C&I	Mechanical
i). Enabling works	i). Electrical	i). Boiler & Aux (All types including CW Piping if applicable)
ii). Pile and Pile Caps	ii). C&I	ii). Power Cycle Piping/Critical Piping
iii). Civil Works including foundations	iii). Others (Elect. and C&I)	iii). ESP
iv). Structural Steel Fabrication & Erection		iv). LP Piping
v). Chimney		v). Steam Turbine Generator set & Aux
		vi). Gas Turbine Generator set & Aux

vi). Cooling Tower vii). Others (Civil)		vii). Hydro Turbine Generator set & Aux viii). Turbo Blower (including Steam Turbine) ix). Material Management x). Others (Mechanical)
--	--	---

- iii). Bidders who have not been evaluated for at least six package months in the last 36 months preceding and including the Cut-off month in the online BHEL system for contractor performance evaluation in BHEL PS Regions, shall be considered "NEW VENDOR".

A 'NEW VENDOR' shall be considered qualified subject to satisfying all other tender conditions.

A 'NEW VENDOR' if awarded a job (of package/packages identified under this clause) shall be tagged as "FIRST TIMER" on the date of first LOI from BHEL.

The "FIRST TIMER" tag shall remain till execution of work for a period of not less than 09 months from the commencement of work of first package or completion of contract or availability of 6 evaluation scores including the previous scores (if any).

A Bidder shall not be eligible for the next job as long as the Bidder is tagged as "FIRST TIMER" excepting for the Tenders which have been opened on or before the date of the bidder being tagged as 'FIRST TIMER'.

After removal of 'FIRST TIMER' tag, the Bidder shall be considered 'QUALIFIED' for the future tenders subject to satisfying all other tender conditions including 'Assessment of Capacity of Bidders'.

- iv). In the unlikely event of all bidders shortlisted against Technical and Financial Qualification criteria not meeting the criteria on 'Assessment of Capacity of Bidders' detailed above, OR leads to a single tender response on applying the criteria of 'Assessment of Capacity of Bidders' OR due to non-approval by Customer, then BHEL at its discretion reserves the right to consider the further processing of the Tender based on the **Overall Performance Rating 'R<sub>BHEL</sub>'** only, starting from the upper band.
- v). 'Under execution' shall mean works in progress as per the following:
- Up to execution of 90% of anticipated Contract Value in case of Civil, MM, Structural and Turbo Blower Packages
  - Up to Steam Blowing in case of Boiler/ESP/Piping Packages
  - Up to Synchronization in all Balance Packages
- Note: BHEL at its discretion can extend (or reduce in exceptional cases in line with Contract conditions) the period defined against (a), (b) and (c) above, depending upon the balance scope of work to be completed.
- vi). Contractor shall provide the latest contact details i.e. mail-ID and Correspondence Address to SCT Department, so that same can be entered in the Contractor Performance Evaluation System, and in case of any change/discrepancy same shall be informed immediately. Login Details for viewing scores in Contractor Performance Evaluation System shall be provided to the Contractor by SCT Department.
- vii). Performance Evaluation for Activity Month shall be completed in Evaluation Month (i.e. month next to Activity Month) or in rare cases in Post Evaluation Month (i.e. month next to Evaluation Month) after approval from Competent Authority. In case scores are not acceptable, Contractor can submit Review Request to GM Site/ GM Project latest by 25<sup>th</sup> of Evaluation Month or 3 days after approval of score, whichever is later. However, acceptance/rejection of 'Review Request' solely depends on the discretion of GM Site/GM Project. After acceptance of Review Request, evaluation score shall be reviewed at site and the score after completion of review process shall be acceptable and binding on the contractor.
- viii). Project on Hold due to reasons not attributable to bidder -
- Short hold:** Evaluation shall not be applicable for this period, however Loading will be considered.

- b. **Long hold:** Short hold for continuous six months and beyond or hold on account of Force Majeure shall be considered as Long Hold. Evaluation as well as Loading shall not be considered for this period.
- ix). Performance evaluation in CL 9 above is applicable to prime bidder and Consortium partner (or Technical tie up partner) for their respective scope of work.
10. Since the job shall be executed at site, bidders must visit site/ work area and study the job content, facilities available, availability of materials, prevailing site conditions including law & order situation, applicable wage structure, wage rules, etc before quoting for this tender. They may also consult this office before submitting their offers, for any clarifications regarding scope of work, facilities available at sites or on terms and conditions.
11. For any clarification on the tender document, the bidder may seek the same over e-procurement portal as per specified format, within the scheduled date for seeking clarification, from the office of the undersigned. BHEL shall not be responsible for receipt of queries after due date of seeking clarification due to postal delay or any other delays. Any clarification / query received after last date for seeking clarification may not be normally entertained by BHEL and no time extension will be given.
12. BHEL may decide holding of pre-bid discussion [PBD] with all intending bidders as per date indicated in the NIT. The bidder shall ensure participation for the same at the appointed time, date and place as may be decided by BHEL. Bidders shall plan their visit accordingly. The outcome of pre-bid discussion (PBD) shall also form part of tender.
13. In the event of any conflict between requirement of any clause of this specification/ documents/drawings/data sheets etc or requirements of different codes/standards specified, the same to be brought to the knowledge of BHEL in writing for clarification before due date of seeking clarification (whichever is applicable), otherwise, interpretation by BHEL shall prevail. Any typing error/missing pages/ other clerical errors in the tender documents, noticed must be pointed out before pre-bid meeting/submission of offer, else BHEL's interpretation shall prevail.
14. Unless specifically mentioned otherwise, bidder's quoted price shall deemed to be in compliance with tender including PBD.
15. ~~Bidders shall submit Integrity Pact Agreement (Duly signed by authorized signatory who signs in the offer), if applicable, along with techno-commercial bid. This pact shall be considered as a preliminary qualification for further participation. The names and other details of Independent External Monitor (IEM) for the subject tender is as given at Clause No. 1, Salient Features of NIT, Sl. No. (xi) above.~~
- 15a. **Integrity Pact (IP): Not Applicable**
16. The Bidder has to satisfy the Pre Qualifying Requirements stipulated for this Tender in order to be qualified. The Price Bids of only those bidders will be opened who will be qualified for the subject job on the basis of satisfying the Pre Qualification Criteria specified in this NIT as per Annexure-I (as applicable), past performance etc. and date of opening of price bids shall be intimated to only such bidders. BHEL reserves the right not to consider offers of parties under HOLD.
17. In case BHEL decides on a 'Public Opening', the date & time of opening of the PRICE BID shall be intimated to the qualified bidders and in such a case, bidder may depute one authorised representative to witness the price bid opening. BHEL reserves the right to open 'in-camera' the 'PRICE BID' of any or all Unsuccessful/Disqualified bidders under intimation to the respective bidders-
18. Validity of the offer shall be for **six months** from the latest due date of offer submission (including extension, if any) unless specified otherwise
19. (a) BHEL reserves the right to go for Reverse Auction (RA) (Guidelines as available on [www.bhel.com](http://www.bhel.com)) instead of opening the sealed envelope price bid, submitted by the bidder. This will be decided after techno-commercial evaluation. Bidders to give their acceptance with the offer for participation in RA. Non-

acceptance to participate in RA may result in non-consideration of their bids, in case BHEL decides to go for RA.

- (b) Those bidders who have given their acceptance to participate in Reverse Auction will have to necessarily submit 'Process compliance form' (to the designated service provider) as well as 'Online sealed bid' in the Reverse Auction. Non-submission of 'Process compliance form' or 'Online sealed bid' by the agreed bidder(s) will be considered as tampering of the tender process and will invite action by BHEL as per extant guidelines for suspension of business dealings with suppliers/ contractors (as available on [www.bhel.com](http://www.bhel.com)).
- (c) The bidders have to necessarily submit online sealed bid less than or equal to their envelope sealed price bid already submitted to BHEL along with the offer. **The envelope sealed price bid of successful L1 bidder in RA, if conducted, shall also be opened after RA and the order will be placed on lower of the two bids (RA closing price & envelope sealed price) thus obtained. The bidder having submitted this offer specifically agrees to this condition and undertakes to execute the contract on thus awarded rates.**
- (d) If it is found that L1 bidder has quoted higher in online sealed bid in comparison to envelope sealed bid for any item(s), the bidder will be issued a warning letter to this effect. However, if the same bidder again defaults on this count in any subsequent tender in the unit, it will be considered as fraud and will invite action by BHEL as per extant guidelines for suspension of business dealings with suppliers/ contractors (as available on [www.bhel.com](http://www.bhel.com)).
- (e) If reverse auction process is unsuccessful, sealed envelope price bids of all the techno-commercially qualified bidders shall be opened and the tender shall be processed accordingly. However, the envelope sealed bid(s) of techno-commercially acceptable bidder(s) who had agreed to participate in the RA and had failed to submit the online sealed bid shall not be opened.
20. On submission of offer, further consideration will be subject to compliance to tender & qualifying requirement and customer's acceptance, as applicable.
21. In case the bidder is an "Indian Agent of Foreign Principals", 'Agency agreement has to be submitted along with Bid, detailing the role of the agent along with the terms of payment for agency commission in INR, along with supporting documents.
22. The bidders shall not enter into any undisclosed M.O.U. or any understanding amongst themselves with respect to tender.
23. **Consortium Bidding (or Technical Tie up) : Not Applicable**
24. The bidder shall upload documents in support of possession of 'Qualifying Requirements' duly self-certified and stamped by the authorized signatory, indexed and properly linked in the format for PQR. In case BHEL requires any other documents/proofs, these shall be submitted immediately.
25. The bidder may have to produce original document for verification if so decided by BHEL.
26. The offers of the bidders who are on the banned/ hold list as also the offer of the bidders, who engage the services of the banned/ hold firms, shall be rejected. The list of **banned/ hold firms** is available on BHEL web site [www.bhel.com](http://www.bhel.com).
- 27.0 It may please be noted that **guidelines/rules** in respect of Suspension of Business dealings', 'Vendor evaluation format', 'Quality, Safety & HSE guidelines', milestone/ completion certificate, etc may **undergo change** from time to time and the latest one shall be followed. The abridge version of extant 'Guidelines for suspension of business dealings with suppliers/ contractors' is available on [www.bhel.com](http://www.bhel.com) on "**supplier registration page**".

The offers of the bidders who are under suspension as also the offers of the bidders, who engage the services of the banned firms, shall be rejected. The list of banned firms is available on BHEL website ([www.bhel.com](http://www.bhel.com)).

27.1 Integrity commitment, performance of the contract and punitive action thereof:

27.1.1 **Commitment by BHEL:**

BHEL commits to take all measures necessary to prevent corruption in connection with the tender Process and execution of the contract. BHEL will during the tender process treat all Bidder(s) in a transparent and fair manner, and with equity.

27.1.2 **Commitment by Bidder/ Supplier/ Contractor:**

- (i) The bidder/ supplier/ contractor commit to take all measures to prevent corruption and will not directly or indirectly influence any decision or benefit which he is not legally entitled to nor will act or omit in any manner which tantamount to an offence punishable under any provision of the Indian Penal Code, 1860 or any other law in force in India.
- (ii) The bidder/ supplier/ contractor will, when presenting his bid, disclose any and all payments he has made, and is committed to or intends to make to agents, brokers or any other intermediaries in connection with the award of the contract and shall adhere to relevant guidelines issued from time to time by Govt. of India/ BHEL.
- (iii) The bidder/ supplier/ contractor will perform/ execute the contract as per the contract terms & conditions and will not default without any reasonable cause, which causes loss of business/ money/ reputation, to BHEL.

If any bidder/ supplier/ contractor during pre-tendering/ tendering/ post tendering/ award/ execution/ post-execution stage indulges in mal-practices, cheating, bribery, fraud or and other misconduct or formation of cartel so as to influence the bidding process or influence the prices or acts or omits in any manner which tantamount to an offence punishable under any provision of the Indian Penal Code, 1860 or any other law in force in India, then, action may be taken against such bidder/ supplier/ contractor as per extant guidelines of the company available on [www.bhel.com](http://www.bhel.com) and / or under applicable legal provisions.

28.0 **Micro and Small Enterprises (MSE)**

Any Bidder falling under MSE category, shall furnish the following details & submit documentary evidence/ Govt. Certificate etc. in support of the same along with their techno-commercial offer

Type under MSE	SC/ST owned	Others
Micro		
Small		

**Note:** - If the bidder does not furnish the above, offer shall be processed construing that the bidder is not falling under MSE category.

- a) MSE suppliers can avail the intended benefits only if they submit along with the offer, attested copies of either Udyog Aadhaar or EM-II certificate having deemed validity (five years from the date of issue of acknowledgement in EM-II) or valid NSIC certificate or EM-II certificate along with attested copy of a CA certificate (format enclosed as Annexure – 3) where deemed validity of EM-II certificate of five years has expired applicable for the last audited financial year. Date to be reckoned for determining the deemed validity will be the last date of Technical Bid submission. Non submission of such documents will lead to consideration of their bids at par with other bidders. No benefits shall be applicable for this enquiry if the above required documents are not submitted before price bid opening. If the tender is to be submitted through e-procurement portal, then the above required documents are to be uploaded on the portal.
- b) MSEs shall be exempted from payment of tender fee.
- c) MSEs shall be exempted from payment of earnest money at the time of tender deposit. However, there is no exemption of security deposit submission.
- d) Participating MSEs quoting price within price band of L1+15 % shall be considered for award of complete scope of work by bringing down their price to L1 price in a situation where L1 price is from someone other than a MSE. In case of more than one such MSE, MSE with lowest price shall be given the first option to match the L1 price. However, MSEs owned by the Scheduled Caste or the Scheduled Tribe entrepreneurs

shall be given the preference for matching the L1 price irrespective of their standing in comparative statement of MSE bidders within price band of L1+15 %.

29.0 The Bidder along with its associate/ collaborators/ sub-contractors/ sub-vendors/ consultants/ service providers shall strictly adhere to BHEL Fraud Prevention Policy displayed on BHEL website <http://www.bhel.com> and shall immediately bring to the notice of BHEL Management about any fraud or suspected fraud as soon as it comes to their notice.

### 30.0 Order of Precedence

In the event of any ambiguity or conflict between the Tender Documents, the order of precedence shall be in the order below:

- a. Amendments/Clarifications/Corrigenda/Errata etc issued in respect of the tender documents by BHEL
- b. Notice Inviting Tender (NIT)
- c. Price Bid
- d. Technical Conditions of Contract (TCC)—Volume-1A
- e. Special Conditions of Contract (SCC) —Volume-1B
- f. General Conditions of Contract (GCC) —Volume-1C
- g. Forms and Procedures —Volume-1D

for BHARAT HEAVY ELECTRICALS LTD  
(SCT)

### **Enclosure:-**

- (i) Annexure-1: Pre Qualifying criteria.
- (ii) Annexure-2: Check List.
- (iii) Annexure-3: Chartered Accountant certificate for MSMED
- (iv) Annexure-4: Authorization of representative who will participate in the online Reverse Auction Process
- (v) Annexure-5: Feedback form
- (vi) Other Tender documents as per this NIT.

**ANNEXURE - 1****PRE QUALIFYING REQUIREMENTS**

JOB	GEOTECHNICAL INVESTIGATION AND TOPOGRAPHICAL SURVEY FOR 1X660 MW PANKI THERMAL POWER STATION, KANPUR, U.P.
TENDER NO	BHEL/ NR/SCT/PANKI/GEOTECH INV/1078

SL. NO.	NAME AND DESCRIPTION OF PRE QUALIFICATION CRITERIA	Bidders claim in respect of fulfilling the PQR Criteria
A	Submission of Integrity Pact	Not Applicable
B	Assessment of Capacity of bidder to execute the work as per clause 9.0 pf NIT	Applicable – By BHEL
C	<b><u>TECHNICAL</u></b>	
C-1	<b><u>Bidder who wish to participate should have:</u></b> Executed ' <b>Similar Work</b> ' for any one of the following in the last 7 years from latest date of bid submission:	
C-1.1	One (01) work of value not less than the amount equal to <b>Rs. 55.96 Lakhs</b>	Applicable
	<b>OR</b>	
C-1.2	Two (02) works each of value not less than the amount equal to <b>Rs. 34.98 Lakhs.</b>	
	<b>OR</b>	
C-1.3	Three (03) works each of value not less than the amount equal to <b>Rs. 27.98 Lakhs.</b>	
D	<b><u>FINANCIAL</u></b>	
D-1	<b><u>TURNOVER:</u></b> Bidders must have achieved an average annual financial turnover (Audited) of <b>Rs. 20.99 Lakhs</b> or more over last three Financial Years (FY) i.e. (2014-15, 2015-16 and 2016-17). Bidder shall submit audited accounts (balance sheets and profit & loss account) in support of this.  In case audited financial statements have not been submitted for all the three years as indicated above, then the applicable audited statements submitted by the bidders against the requisite three years, will be averaged for three years.  If financial statements are not required to be audited statutorily, then instead of audited financial statements, financial statements are required to be certified by Chartered Accountant.	Applicable
D-2	<b><u>NET WORTH:</u></b> Net worth (only in case of companies) of the Bidder should be positive.  Net worth shall be calculated based on the latest Audited Accounts as furnished for 'D-1' above.  Net worth = Paid up share capital* + Reserves (* : Share Capital OR Partnership Capital OR Proprietor Capital as the case may be)	
D-3	<b><u>PROFIT:</u></b> Bidder must have earned profit in any one of the three financial years as applicable in the last three financial years as furnished for 'D-1' above.  PROFIT shall be PBT earned during any one year of last three financial years as in 'D-1' above.	

<b>E</b>	Approval of Customer	Not Applicable
<b>F</b>	Consortium Criteria	Not Applicable

**Explanatory Notes:**

1. The word '**Similar Works**' means Geotechnical Investigation & Topographical Survey work for any kind of Project (Residential/ Commercial/ Industrial).
2. For evaluation of PQR, the credentials of the bidder alone, and not that of the Group Company shall be considered.
3. For sl. no. 'C.1.0', 'Executed' means the bidder should have achieved this criteria, even if the total contract has not been completed or closed. Actual executed value shall be considered, irrespective of completion status of contract (s) under consideration.
4. For sl.no. 'C.1.0' above Value of work is to be updated with indices for "All India Avg. Consumer Price index for industrial workers" and "Monthly Whole Sale Price Index for All Commodities" with base month as per last month of work execution and indexed up to three (3) months prior to the month of latest due date of bid submission as per following formula-

$$P = \left\{ R + 0.425 \times R \times \frac{(X_N - X_0)}{X_0} + 0.425 \times R \times \frac{(Y_N - Y_0)}{Y_0} \right\}$$

Where

P = Updated value of work

R = Value of executed work

XN = All India Avg. Consumer Price index for industrial workers for the month, three months prior to the month of latest due date of bid submission (e.g. If latest bid submission date is 03-Apr-17, then bid submission month shall be reckoned as April'17 and index for Jan'17 shall be considered).

X0 = All India Avg. Consumer Price index for industrial workers for last month of work execution

YN = Monthly Whole Sale Price Index for All Commodities for the month, three months prior to the month of latest due date of bid submission (e.g. If latest bid submission date is 03-Apr-17, then bid submission month shall be reckoned as April'17 and index for Jan'17 shall be considered).

Y0 = Monthly Whole Sale Price Index for All Commodities for last month of work execution.

BIDDER SHALL SUBMIT ABOVE PRE-QUALIFICATION CRITERIA FORMAT, DULY FILLED-IN, SPECIFYING RESPECTIVE ANNEXURE NUMBER AGAINST EACH CRITERIA AND FURNISH RELEVANT DOCUMENT INCLUSIVE OF WORK ORDER AND WORK COMPLETION CERTIFICATE ETC IN THE RESPECTIVE ANNEXURES IN THEIR OFFER.

**ANNEXURE - 2****CHECK LIST****NOTE:- Tenderers are required to fill in the following details and no column should be left blank**

1	Name and Address of the Tenderer		
2	Details about type of the Firm/Company		
3.a	Details of Contact person for this Tender	Name : Mr/Ms Designation: Telephone No: Mobile No: Email ID: Fax No:	
3.b	Details of alternate Contact person for this Tender	Name : Mr/Ms Designation: Telephone No: Mobile No: Email ID:	
4	EMD DETAILS	DD No:                      Date : Bank :                      Amount:	
5	Validity of Offer	TO BE VALID FOR SIX MONTHS FROM DUE DATE	
		APPLICABILITY(BY BHEL)	ENCLOSED BY BIDDER
6	Whether the format for compliance with <b>PRE QUALIFICATION CRITERIA</b> (ANNEXURE-I) is understood and filled with proper supporting documents referenced in the specified format	Applicable	YES / NO
7	Audited profit and Loss Account for the last three years	Applicable	YES/NO
8	Copy of PAN Card	Applicable	YES/NO
9	Whether all pages of the Tender documents including annexures, appendices etc are read understood and signed	Applicable	YES/NO
10	Integrity Pact	<b>Not Applicable</b>	YES/NO
11	Declaration by Authorised Signatory	Applicable	YES/NO
12	No Deviation Certificate	Applicable	YES/NO
13	Declaration confirming knowledge about Site Conditions	Applicable	YES/NO
14	Declaration for relation in BHEL	Applicable	YES/NO
15	Non Disclosure Certificate	Applicable	YES/NO
16	Bank Account Details for E-Payment	Applicable	YES/NO
17	Capacity Evaluation of Bidder for current Tender	Applicable	YES/NO
18	Tie Ups/Consortium Agreement are submitted as per format	<b>Not Applicable</b>	YES/NO
19	Power of Attorney for Submission of Tender/Signing Contract Agreement	Applicable	YES/NO
20	Analysis of Unit rates	Applicable	YES/NO

NOTE : STRIKE OFF 'YES' OR 'NO', AS APPLICABLE. TENDER NOT ACCOMPANIED BY THE PRESCRIBED **ABOVE APPLICABLE DOCUMENTS** ARE LIABLE TO BE SUMMARILY REJECTED.

DATE :

**AUTHORISED SIGNATORY**  
(With Name, Designation and Company seal)

**ANNEXURE - 3****Certificate by Chartered Accountant on letter head**

This is to Certify that M/S ..... ,  
 (hereinafter referred to as 'company') having its registered office at .....  
 ..... is registered under MSMED Act 2006, (Entrepreneur  
 Memorandum No (Part—II) ..... dtd:.....,  
 Category: ..... (Micro/Small)). (Copy enclosed).

Further verified from the Books of Accounts that the investment of the company as per the  
 latest audited financial year..... as per MSMED Act 2006 is as follows:

**1. For Manufacturing Enterprises:** Investment in plant and machinery (i.e. original cost excluding  
 land and building and the items specified by the Ministry of Small Scale Industries vide its notification No.  
 S.O.1722(E) dated October 5, 2006:  
 Rs..... Lacs

**2. For Service Enterprises:** Investment in equipment (original cost excluding land and building and  
 furniture, fittings and other items not directly related to the service rendered or as may be notified under the **MSMED**  
 Act, 2006:  
 Rs..... Lacs

**(Strike off which is not applicable)**

The above investment of Rs .....Lacs is within permissible limit of  
 Rs..... Lacs for .....Micro / Small **(Strike off which is not applicable)**  
 Category under MSMED Act 2006.

Or

The company has been graduated from its original category (Micro/Small) (Strike off which is not applicable) and  
 the date of graduation of such enterprise from its original category is ..... (dd/mm/yyyy) which is within  
 the period of 3 years from the date of graduation of such enterprise from its original category as notified vide S.O.  
 No. 3322(E) dated 01.11.2013 published in the gazette notification dated 04.11.2013 by Ministry of MSME.

Date:

(Signature)

Name-

Membership Number-

Seal of Chartered Accountant

**ANNEXURE - 4****Authorization of representative who will participate in the on line Reverse Auction (RA) Process;**

1	NAME & DESIGNATION OF OFFICIAL	
2	POSTAL ADDRESS (COMPLETE)	
3	TELEPHONE NOS. (LAND LINE & MOBILE BOTH)	
4	FAX NO.	
5	E-MAIL ADDRESS	
6	NAME OF PLACE/ STATE/ COUNTRY, WHEREFROM S/HE WILL PARTICIPATE IN THE REVERSE AUCTION	

**ANNEXURE – 5****Feedback Form: From where did you get information regarding this tender**

1	NEWSPAPER ADVERTISEMENT (NAME)	
2	BHEL WEBISTE (TENDER NOTIFICATION)	
3	CENTRAL PUBLIC PROCUREMENT PORTAL OF GOVERNMENT OF INDIA (CPP PORTAL)	
4	EMAIL COMMUNICATION FROM BHEL	
5	ANY OTHER SOURCE	



**VOLUME- IA: TECHNICAL  
CONDITIONS OF CONTRACT (TCC)**

**NAME OF WORK: GEOTECHNICAL  
INVESTIGATION AND TOPOGRAPHICAL  
SURVEY FOR 1X660 MW PANKI  
THERMAL POWER STATION, KANPUR,  
U.P.**

**BHARAT HEAVY ELECTRICALS  
LIMITED**



# TECHNICAL CONDITIONS OF CONTRACT (TCC) CONTENTS

SI No	DESCRIPTION	Chapter	Page No.
<b>Volume-IA</b>	<b>Part-I: Contract specific details</b>		
1	Project Information	Chapter-I	3
2	Scope of Works	Chapter-II	4-5
3	Facilities in the scope of Contractor/BHEL (Scope Matrix)	Chapter-III	6-8
4	T&Ps and MMEs to be deployed by Contractor	Chapter-IV	9
5	T&Ps and MMEs to be deployed by BHEL on sharing basis	Chapter-V	10
6	Time Schedule	Chapter-VI	11
7	Terms of Payment	Chapter-VII	12
8	Taxes and other Duties	Chapter-VIII	13-14
9	Materials & Other Requirements	Chapter-IX	15-16
10	Other Important Conditions	Chapter-X	17-20
11	Annexures	Chapter- XI	21 - 27
<b>Volume-IA</b>	<b>Part-II : Technical Specifications</b>		<b>No. of Sheets</b>
1	Standard Specifications for Geotechnical Investigation	Specification No. PE-TS-999-603-002	51
2	Technical Specification for Topographical Survey	Specification No. PE-DC-K57-601-C001 Vol. II	12
3	Tender Drawing- Topographical Survey & Geotechnical Investigation Layout	PE-DG-K57-601-C001	1

# TECHNICAL CONDITIONS OF CONTRACT (TCC)

## Chapter - I : Project Information

### **Panki Thermal Power Station (1x660 MW)**

UTTAR PRADESH RAJYA VIDYUT UTPADAN NIGAM LTD., LUCKNOW has entrusted BHEL a turnkey contract to setup Panki Thermal Power Station (1X660 MW), Kanpur (U.P.).

Sl. No.	Title	Description
1	Owner	UTTAR PRADESH RAJYA VIDYUT UTPADAN NIGAM LIMITED, LUCKNOW
2	Project Title	Panki Thermal Power Station (1X660 MW)
3	Project Site Location	Panki, Kanpur, U.P., India
4	Nearest Railway Station	Panki (5 Km.)
5	Nearest Airport	Kanpur (25 Km.), Lucknow (80 Km.)
6	Extreme Recorded DBT	Maximum (47.3°C) , Minimum (-0.9°C)
7	Average Relative Humidity	Annual Average (65%)
8	Rainfall	Annual Average (832.6 mm)
9	Nearest Water Body	Lower Ganga Canal (adjacent to site)
10	Basic Wind Speed	47.0 m/s (As per IS: 875 Part-III)
11	Seismic Data	Zone-III (As per IS: 1893)

The Nearest Town Kanpur is about 16 Km from site and is easily accessible by Road/ Railway.

**Note:** - The bidder is advised to visit and examine the site of WORKS and its surroundings and obtain for himself on his own responsibility all information that may be necessary for preparing the bid and entering into the CONTRACT. All costs for and associated with site visits shall be borne by the bidder.

# TECHNICAL CONDITIONS OF CONTRACT (TCC)

## Chapter - II: Scope of Works

---

### **2.0 GENERAL SCOPE OF WORK**

- 2.1** It is proposed to get detailed soil investigations done at the site of the Power Plant to establish various soil parameters to enable design of plant buildings, equipment and other structural foundations. Topographical Survey and Soil investigation work has to be carried out as per the details given in BOQ cum rate schedule, Technical Specification and drawings. Exact locations of the Tests etc. will be indicated before commencement of work
- 2.2** Details of items shall be read in conjunction with the corresponding specification, drawings and other tender terms.
- 2.3** The bidder shall quote for finished items of work and shall provide all necessary power, water, instruments, fuel, tools and plants, tackles, materials, transport, labour, supervision and maintenance till handing over, repairs, rectifications, safety and security of their workmen and equipment including insurance etc.
- 2.4** All the field and laboratory tests shall be done in accordance with BHEL's soil investigation spec and relevant IS codes, whichever is more stringent.
- 2.5** The bidder shall submit a scheme showing the arrangement and equipment proposed to be used for conducting the work along with the rates.
- 2.6** BHEL Engineer's decision regarding clarification of items in the BOQ cum rate schedule with respect to other sections of the contract shall be final and binding on the contractor.
- 2.7** The complete works shall be carried out as per **BOQ cum Rate schedule**. If any work covered in the scope of contract cannot be executed using items available in BOQ, additional / extra items shall be made and rates for such items shall be worked out as per **GCC clause 2.15.7**. However contractor shall be bound to execute all the works under the scope of the contract and decision whether an extra item is applicable or not, shall be taken by BHEL Engineer, which shall be binding on the contractor.
- 2.8** In case the description / specifications as per BOQ are found to be incomplete, Indian Standard Codes (IS Codes) specifications shall be followed. Quantities mentioned in the BOQ cum Rate Schedules, are approximate only and liable for variation due to change of scope of work / variation in schedule of quantities, changes in design etc. The tenderers shall undertake to execute actual quantities as per advice of BHEL Engineer and accordingly the final contract price shall be worked out on the basis of quantities actually executed at site and payments will also be regulated for the same.
- 2.9** Any activity which is necessarily required for satisfactory execution of any item of BOQ in line with technical specifications shall be deemed to be included in BOQ item even if

# TECHNICAL CONDITIONS OF CONTRACT (TCC)

## Chapter - II: Scope of Works

---

it is not described in the item description and no extra payment shall be made against such activity.

### **2.10 Also included in the scope :**

The scope broadly covers the following:

- 2.10.1 Carry out field tests in the form of test boring including drilling through rocks (if required), direct load tests, penetration tests, trial pits, tests for dynamic properties, electrical resistivity tests, block vibration test, laboratory tests etc. and topographical survey listed in BOQ cum Rate Schedule.
  - 2.10.2 Preparation and submission of preliminary report (in duplicate) containing firm recommendation on the type of foundation to be adopted. This report shall include details of bore-logs, trial pits, plate load tests, cone penetration tests, relevant dynamic tests etc. based on which the recommendations were arrived at. The recommendation shall be supported by necessary calculations.
  - 2.10.3 Preparation and submission of Draft Final Report (in triplicate) covering the entire scope of work and giving the recommendations as per the requirements.
  - 2.10.4 Preparation and submission of Final Report incorporating the comments of BHEL on the draft report. Five (5) hard copies of the final report along with two (2) soft copy in CD of all annexure to the report (bore logs, graphs, tables, charts etc.) shall be submitted.
- 2.11** The work to be performed under this specification consists of providing labor, supervision, all materials, scaffoldings, Construction equipment, tool & plants, supplies, transportation and storage of all items including contractor's supervision and in accordance with drawings and specifications.

**TECHNICAL CONDITIONS OF CONTRACT (TCC)**  
**Chapter – III: Facilities in the scope of Contractor/BHEL**

---

Sl. No	Description	Scope / to be taken care by		Remarks
		BHEL	Bidder	
3.1.0	<b>ESTABLISHMENT</b>			
3.1.1	FOR CONSTRUCTION PURPOSE:			
A	Open space for office	Yes		BHEL shall provide free of charge limited open space for office and store as and where made available by its customer
B	Open space for storage	Yes		
C	Construction of bidder's office, canteen and storage building including supply of materials and other services		Yes	
D	Bidder's all office equipment, office / store / canteen consumables		Yes	
E	Canteen facilities for the bidder's staff, supervisors and engineers etc.		Yes	
F	Firefighting equipment like buckets, extinguishers etc.		Yes	
G	Fencing of storage area, office, canteen etc. of the bidder		Yes	
3.1.2	<b>FOR LIVING PURPOSES OF THE BIDDER</b>			
A	Open space		Yes	
B	Living accommodation		Yes	
3.2.0	<b>ELECTRICITY</b>			
3.2.1	<b><u>Electricity For construction purposes</u></b>		Yes	Construction Power can be provided at single point source as and where made available by Owner, however contract has to deploy DG Sets at no extra cost to BHEL.
3.2.1.1	Single point source		Yes	

**TECHNICAL CONDITIONS OF CONTRACT (TCC)**  
**Chapter – III: Facilities in the scope of Contractor/BHEL**

Sl. No	Description	Scope / to be taken care by		Remarks
		BHEL	Bidder	
3.2.1.2	Further distribution for the work to be done which include supply of materials and execution.		Yes	
<b>3.2.2</b>	<b><u>Electricity for the office, stores, canteen etc. of the bidder which include:</u></b>		Yes	
3.2.2.1	Distribution from single point including supply of materials and service		Yes	
3.2.2.2	Supply, installation and connection of material of energy meter including operation and maintenance		Yes	
3.2.2.3	Duties and deposits including statutory clearances for the above		Yes	
3.2.2.4	Living facilities for office use including charges		Yes	
3.2.2.5	Demobilization of the facilities after completion of works		Yes	
3.2.3	Electricity for living accommodation of the bidder's staff, engineers, supervisors etc. on the above lines.		Yes	
<b>3.3.0</b>	<b><u>WATER SUPPLY</u></b>			
<b>3.3.1</b>	<b><u>For construction purposes:</u></b>			
3.3.1.1	Making the water available at single point		<b>Yes</b>	
3.3.1.2	Further distribution as per the requirement of work including supply of materials and execution		Yes	
<b>3.3.2</b>	<b><u>Water supply for bidder's office, stores, canteen etc.</u></b>		Yes	
3.3.2.1	Making the water available at single point		Yes	

**TECHNICAL CONDITIONS OF CONTRACT (TCC)**  
**Chapter – III: Facilities in the scope of Contractor/BHEL**

Sl. No	Description	Scope / to be taken care by		Remarks
		BHEL	Bidder	
3.3.2.2	Further distribution as per the requirement of work including supply of materials and execution		Yes	
3.4.0	<b>LIGHTING</b>			
3.4.1	For construction work (supply of all the necessary materials) 1. At office storage area 2. At the construction site /area		Yes	
3.4.2	For construction work (execution of the lighting work/ arrangements ) 1. At office storage area 2. At the construction site /area		Yes	
3.4.3	Providing the necessary consumables like bulbs, switches, etc. during the course of construction		Yes	
3.4.4	Lighting for the living purposes of the bidder at the colony / quarters		Yes	
3.5.0	<b>COMMUNICATION FACILITIES FOR SITE OPERATIONS OF THE BIDDER</b>			
3.5.1	Telephone, fax, internet, intranet, e-mail etc		Yes	
<b>3.6.0</b>	<b>Engineering works for construction:</b>			
3.6.1	Providing the construction drawings for all the works covered under this scope	Yes		
3.6.2	Drawings for construction methods		Yes	In consultation with BHEL
3.6.6	Review of performance and revision of site construction schedules in order to achieve the end dates and other commitments.	Yes	Yes	"

**TECHNICAL CONDITIONS OF CONTRACT (TCC)**  
**Chapter – IV: T&Ps and MMEs to be deployed by Contractor**

---

**A. LIST OF TOOL & PLANTS TO BE DEPLOYED BY THE CONTRACTOR -**

INDICATIVE LIST OF T & P TO BE ARRANGED BY THE CONTRACTOR AT HIS OWN COST

Sl. No.	EQUIPMENT	QTY. (INDICATIVE)
1	Boring Rig for soil/Rotary core Drilling Rig with accessories	5 NO. / APR
2	Static Cone Penetration Test Setup	1 NO / APR
3	Dynamic Cone Penetration Test Setup	1 NO. / APR
4	Equipment for Plate Load Test	1NO. / APR
5.	Equipment for Field Permeability Test	1 NO. / APR
6	Pressure meter Test Setup	1 NO. / APR
7	Seismic Refraction test set up	1 NO. / APR
8	Electrical Resistivity Test	1 NO. / APR
9	Cross Hole Shear test	1 NO. / APR
10	Electronic Total Station & accessories	1 NO. / APR

\*APR: As Per Requirement.

NOTES:

- 1 The above list is only indicative and these T&Ps may not be required for entire contract period but contractor will ensure that these T & Ps are provided as per need. Contractor will assess actual quantity and period of requirement based on his experience. **Contractor has to mobilize / maintain adequate numbers of equipment for meeting the work schedule and intermediate milestones as notified by BHEL Engineer.**
- 2 Other terms and conditions regarding T&Ps / MMEs please also refer clause for T&Ps & MMEs in other Tender Specifications.
- 3 All the tools and plants required for this scope of work are to be arranged by the contractor within the quoted rates. The list is suggestive in nature. Any additional T&Ps required to be arranged by the contractor.
- 4 If work gets delayed due to non-availability of T&Ps, BHEL reserves the right to get the work done at the risk and cost of contractor without prejudice to rights of BHEL as in GCC.

**NOT APPLICABLE**

# TECHNICAL CONDITIONS OF CONTRACT (TCC)

## Chapter – VI: Time Schedule

---

### **6.0 MOBILIZATION, TIME SCHEDULE, CONTRACT PERIOD AND GRACE PERIOD**

#### **6.1 INITIAL MOBILIZATION:**

After receipt of fax LOI, Contractor shall discuss with Project Manager / Construction Manager regarding initial mobilization. Contractor shall mobilize necessary resources within 2 weeks of issue of fax letter of intent or as per the directive of Project Manager / Construction Manager. Such resources shall be progressively augmented to match the schedule of milestones as directed by BHEL Engineer.

#### **6.2 START DATE / ZERO DATE:**

The schedule date of start of work shall be the date after 2 weeks of issue of LOI; The Actual Date of Start of Contract Period (Zero Date) shall be date of handing over of site for work to contractor and shall be certified by the BHEL Engineer.

#### **6.3 COMPLETION PERIOD:**

The entire work **up to submission of Draft report** is to be completed within **2 ½ months from the actual date of start of contract period (Zero Date)**. All the field work is to be tentatively completed in 2 months' time, Draft report to be submitted by 10<sup>th</sup> week. Contractor has to mobilize adequate resources to meet BHEL's commitments to their customer as indicated from time to time.

**6.4** The Final Report after incorporation of all BHEL comments, required revisions and modifications in Draft Report shall be submitted within one week of specific instructions by BHEL for the same.

**6.5** Detailed Work completion Schedule will be submitted for approval by the successful bidder within 2 weeks of issue of LOI.

**6.6** In case due to reasons not attributable to the contractor, the work gets delayed and scheduled completion gets extended, time extension will be accordingly granted by BHEL.

**6.7** The work under the scope of this contract is deemed to be completed in all respects, only when all the works are carried out as per satisfaction of BHEL. The decision of BHEL on completion date shall be final and binding on the contractor.

**6.8** In order to meet above schedule in general, and any other intermediate targets set, to meet customer/ project schedule requirements, contractor shall arrange & augment all necessary resources from time to time on the instructions of BHEL.

**6.9** This project is a fast track project. Customer is making all out efforts to advance the project schedule. No extra payment whatsoever shall be paid on this account.

#### **6.10 CONSEQUENCE OF DELAY:**

In case of delay in completion is attributable to the contractor, BHEL may impose LD on the contractor as per GCC.

# TECHNICAL CONDITIONS OF CONTRACT (TCC)

## Chapter-VII: Terms of Payment

---

### 7 TERMS OF PAYMENT

- 7.1 The 'Engineer' will certify regarding the actual work executed in the measurement books and bills, which shall be accepted by the contractor in measurement book.
- 7.2 **The Contractor shall be paid monthly running bill as per Chapter - X of SCC and Clause Nos. 2.22 & 2.23 of GCC.** The format for billing shall be approved by BHEL before raising invoices.
- 7.3 The contractor on certification of the engineer at site be entitled for payments of his running bills which shall be subject to any deduction/retention specifically under clauses 2.22 of GCC and 10.0 of SCC in addition to terms of payment as explained hereunder:
- a) 75% of unit rate wise shall be payable on completion of site / lab investigation.
  - b) 15% will be payable on submission of draft report.
  - c) Balance amount shall be payable on acceptance of final reports and on submission and passing of final bill, clearing of site and completion of all contractual responsibilities.

# TECHNICAL CONDITIONS OF CONTRACT (TCC)

## Chapter-VIII: Taxes and Other Duties

---

### **8 TAXES & DUTIES**

**8.1** Price quoted should be inclusive of all applicable Taxes/charges Excluding GST. The Contractor shall pay all other taxes, fees, royalty, commission etc. which may be levied on the contractor in executing the contract. In case BHEL is forced to pay any of such taxes, it shall be recovered from Contactor's bills or otherwise as deemed fit.

**8.2** GST shall be payable extra as per following:

8.2.1 Vendor has to issue correct HSN/SAC code wise bill indicating therein description, value, rate, due tax and other particulars in compliance with the provisions of relevant GST Act and Rules.

8.2.2 Vendor has to submit GST compliant invoice within 7 days from the due date of invoice as per GST Law.

8.2.3 GST portion of invoice shall be released only when all the following conditions are satisfied by the Contractor:

8.2.3.1 Supply of goods and services have been received by BHEL.

8.2.3.2 Original Tax Invoice has been submitted to BHEL.

8.2.3.3 Contractor has declared such invoice in his applicable GST return.

8.2.3.4 Documentary evidence or undertaking regarding discharge of GST liability in respect of supplies made by vendor has been furnished.

8.2.4 For the purposes of claiming GST from BHEL, invoice issued by contractor should be in line with provisions of GST Act & Rules. Special care should be taken in case of month end transactions.

8.2.5 The taxes and duties referred in this chapter or elsewhere in the NIT/contract is limited to direct transactions between BHEL & its Sub-Contractor. BHEL is not responsible for any liability that may arise due to any transaction beyond the direct transaction between BHEL & its Sub-Contractor.

### **8.3 Variation in Taxes & Duties:**

Any upward variation in GST shall be considered for reimbursement provided supply of goods and services are made within schedule date stipulated in the contract.

In case the Government imposes any new levy/tax on the output service/goods after price bid opening, the same shall be reimbursed by BHEL at actual. The reimbursement under this clause is restricted to the direct transaction between BHEL and its contractor only and within the contractual delivery period only.

# TECHNICAL CONDITIONS OF CONTRACT (TCC)

## Chapter-VIII: Taxes and Other Duties

---

In case any new tax/levy/duty etc. becomes applicable after the date of Bidder's offer but before opening of the price Bid, the Bidder/Contractor must convey its impact on his price duly substantiated by documentary evidence in support of the same before opening of price bid. Claim for any such impact after opening the price bid will not be considered by BHEL for reimbursement of tax or reassessment of offer.

### **8.4 Modalities of Tax Incidence on BHEL:**

Where GST law permits more than one option or methodology for discharging liability of tax/levy/ duty; the contractor shall approach BHEL before choosing any option to discharge his tax liability. BHEL shall have the right to direct the contractor to adopt the appropriate option considering the amount of tax liability on BHEL as well as procedural simplicity with regard to assessment of the liability

The option chosen by BHEL shall be binding on the contractor for discharging the obligation of BHEL in respect of the tax liability to the contractor.

### **8.5** Any loss to BHEL due to non-compliance of above noted clauses and/or provisions of the GST Act and/or Rules by the contractor shall be to his account.

# TECHNICAL CONDITIONS OF CONTRACT (TCC)

## Chapter-IX: Materials & Other Requirements

---

### 9.0 MATERIALS

- 9.1 The contractor shall, at his own expenses (Inclusive of Taxes), provide all materials required for the work.
- 9.2 All materials to be provided by the Contractor shall be of the best kind in conformity with the specifications laid down in the contract or as per relevant Indian standard and the Contractor shall, if requested by the BHEL Engineer, furnish proof to the satisfaction of BHEL Engineer that the materials so comply.
- 9.3 The Contractor shall, at his own expense and without delay, supply to the BHEL Engineer samples of materials proposed to be used in the works. The BHEL Engineer shall within seven days of supply of samples or within such further period as he may require will intimate to the Contractor in writing, whether samples are approved by him or not. If samples are not approved, the Contractor shall forthwith arrange to supply to the BHEL Engineer for his approval fresh samples complying with the specifications laid down in the Contract. Any delay in approval of samples (original or fresh ones) shall not make the contractor eligible for any compensation.
- 9.4 The BHEL Engineer shall have full powers for removal of any or all of the materials brought to site by the Contractor which are not in accordance with the Contract specifications or do not conform in character or quality to samples approved by him. In case of default on the part of the Contractor in removing rejected materials, the BHEL Engineer shall be at liberty to have them removed by other means. The BHEL Engineer shall have full powers to procure other proper material to be substituted for rejected materials and in the event of the Contractor refusing to comply; he may cause the same to be supplied by other means. All costs, which may attend upon such removal and / or substitution, shall be borne by the Contractor.
- 9.5 The Contractor shall indemnify BHEL, its representatives or employees against any action, claim or proceeding relating to infringement or use of any patent or design or any alleged patent or design rights and shall pay any royalties or other charges which may be payable in respect of any article or material or part thereof included in the Contract. In the event of any claim being made or action being brought against BHEL or any agent, servant or employee of BHEL in respect of any such matters as aforesaid, the Contractor shall immediately be notified thereof, provided that such indemnity shall not apply when such infringement has taken place in complying with the specific directions issued by BHEL but the Contractor shall pay any royalties or other charges payable in respect of any such use, the amount so paid being reimbursed to the Contractor only if the use was the result of any drawings / specifications issued after submission of the tender.

# TECHNICAL CONDITIONS OF CONTRACT (TCC)

## Chapter-IX: Materials & Other Requirements

---

- 9.6 The BHEL Engineer shall be entitled to have tests carried out as specified in the Contract for any materials supplied by the Contractor other than those for which, as stated above, satisfactory proof has already been furnished, at the cost of the Contractor and the Contractor shall provide at his expense all facilities which the Engineer may require for the purpose. If no tests are specified in the Contract, and such tests are required by the Engineer, the Contractor shall provide all facilities required for the purpose and the charges for these tests shall be borne by the Contractor only. The cost of materials consumed in tests shall be borne by the Contractor in all cases except when otherwise provided.
- 9.7 In addition, the Contractor shall perform / submit at his own cost such tests / samples as may be required by the BHEL Engineer out of the materials used by the company except for the costs of materials used in such tests/ samples.
- 9.8 After acceptance of the Contract, if Contractor desires BHEL to supply any other materials, such material may be supplied by BHEL, if available, at rates to be fixed by the BHEL Engineer along with prevailing departmental charges (current rate of 30%). BHEL reserve the right not to issue any material. The non-issue of such material will not entitle the Contractor for any compensation whatsoever either in time or in cost.
- 9.9 Material required for the works, whether brought by the Contractor or supplied by BHEL, shall be stored by the Contractor only at places approved by the Engineer. Storage and safe custody of material shall be the responsibility of the contractor.
- 9.10 BHEL's officials concerned with the Contract shall be entitled at any time to inspect and examine any materials intended to be used in or on the works, either on the Site or at factory or workshop or other place(s) where such materials are assembled, fabricated, manufactured or at any place (s) where these are lying or from which these are being obtained and the Contractor shall give such facilities as may be required for such inspection and examination.
- 9.11 All materials brought to the Site shall become and remain the property of BHEL and shall not be removed off the Site without the prior written approval of the BHEL Engineer. But whenever the Works are finally completed and advance, if any, in respect of any such material is fully recovered, the Contractor shall at his own expense forthwith remove from the Site all surplus material originally supplied by him and upon such removal, the same shall re-vest in and become the property of the Contractor.

# TECHNICAL CONDITIONS OF CONTRACT (TCC)

## Chapter-X: Other Important Conditions

---

### 10.0 EXECUTION OF WORK

10.1 The work shall be executed in a workman like manner and to the entire satisfaction of the Engineer and as per technical specification issued with tender, IS codes, CPWD specifications as applicable. In case of conflict, the decision of the **BHEL** Engineer shall be final & binding.

### 10.2 SETTING OUT

10.2.1 All the works shall be set out to the true lines, grades and elevation indicated on the drawing. The contractor shall be responsible to locate and set out the works. Only one grid reference line and bench mark **shall** be made available for setting out the works under the contract. This reference lines shall be used as datum for the works under the contract and the contractor has to establish for his work area at available points horizontal and vertical control points. The contractor shall inform BHEL well in advance of the times & places at which he wishes to do work in the area allotted to him so that suitable datum points established by him are checked by BHEL / Customer to enable the contractor to proceed with the works. Any work done without being properly located may be removed and / or dismantled by BHEL / Customer at contractor's expenses.

10.2.2 The contractor shall at his own expense take all proper and responsible precautions to preserve and maintain these datum marks to its true position In the event of these marks being disturbed or obliterated by accident or due to any other cause whatsoever, the same may be deemed necessary placed by BHEL / Customer at contractor's expenses.

### 10.3 SITE DRAINAGE

10.3.1 All water including sub-soil water which may accumulate on the Site during the progress of the works or in trenches and excavations, including monsoon period shall be removed by the contractor from the Site to the satisfaction of the BHEL Engineer. It will also be responsibility of the contractor to de-water all the foundation pits, trenches with suitable de-watering methods like, pumping out, well point system etc. Considering the depth of water table at plant site. All such expenditure on de-watering shall be deemed to be included in quoted rates.

### 10.4 INSPECTION AND STAGE APPROVAL OF THE WORK

10.4.1 The owner or his duly authorized representative shall have at all reasonable times access to the contractor's premises or works and shall have the power to inspect drawings or any portion of the work, examine the materials and workmanship and shall have the authority to reject any work. This would be implemented through joint inspection by the representative of the owner and BHEL and in the form of joint protocols without any extra claims and loss of time and amount.

10.4.2 All work embracing more than one process shall be subject to examination and approval at each stage thereof and the Contractor shall give due notice in writing to the Engineer when each stage is ready. In default of such notice being received, the Engineer shall be entitled to approve the quality and extent thereof at any time he may choose and in the event of any dispute, the decision of the Engineer thereon shall be final and conclusive.

### 10.5 UNCOVERING AND MAKING GOOD

# TECHNICAL CONDITIONS OF CONTRACT (TCC)

## Chapter-X: Other Important Conditions

---

10.5.1 The Contractor shall uncover any part of the Works and/or make openings in or through the same as the BHEL Engineer may from time to time direct for his verification and shall reinstate and make good such part to the satisfaction of the BHEL Engineer. If any such part has been covered up or put out of view after being approved by the BHEL Engineer and is subsequently found on uncovering to be executed in accordance with the Contract, the expenses of uncovering and / or making opening in or through, reinstating and making good the same shall be borne by BHEL. In any other case all such expenses shall be borne by the Contractor.

### 10.6 NUISANCE

10.6.1 The Contractor shall not at any time do, cause or permit any nuisance on Site or do anything which shall cause unnecessary disturbance or inconvenience to owners, tenants or occupiers of other properties near the Site and to the public generally.

### 10.7 MATERIAL OBTAINED FROM EXCAVATION

10.7.1 Materials of any kind obtained from excavation on the Site shall remain the property of BHEL / its client and shall be disposed of as the BHEL Engineer may direct.

### 10.8 TREASURE, TROVE, FOSSILS etc.

10.8.1 All fossils, coins, articles of value or antiquity and structures and other remains or things of geological or archaeological interest discovered on the site shall be the absolute property of BHEL / BHEL's client and the Contractor shall take reasonable precautions to prevent his workmen or any other person from removing or damaging any such article or thing and immediately upon discovery thereof and before removal, acquaint the BHEL Engineer with such discovery and carryout the BHEL Engineer's directions as to the disposal of the same.

### 10.9 PROTECTION OF WORKS

10.9.1 Trees designated by the BHEL Engineer shall be protected from damage during the course of the Works and earth level within 1 meter of each such tree shall not be charged. Where necessary, such trees shall be protected by providing temporary fencing.

10.9.2 The contractor shall provide and maintain at his own expense all lights, guards, fencing and watching when and where necessary or required by the BHEL Engineer for the protection of the Works or for the safety and convenience of those employed on the Works or the public.

10.9.3 The contractor shall have total responsibility for protecting his works till it is finally taken over by the BHEL. No claim will be entertained by the BHEL for any damage or loss to the contractor's works and the contractor shall be responsible for the complete restoration of the damaged works to its original condition to comply with the specifications and drawings. Should any such damage to the contractor's works occur because of other party not under his supervision or control, the contractor shall make his claim directly with the party concerned. The contractor shall not cause any delay in the repair of such damaged works because of any delay in the

# TECHNICAL CONDITIONS OF CONTRACT (TCC)

## Chapter-X: Other Important Conditions

---

resolution of such disputes. The contractor shall proceed to repair the work immediately and no cause thereof will be assigned pending resolution of such disputes.

### 10.10 PROTECTION OF EMBEDMENTS, BOLTS ETC.

10.10.1 The contractor shall ensure proper protection to the satisfaction of the BHEL Engineer, of all bolts, inserts, embedment etc. from weather etc. by greasing, rapping them with gunny bags or canvas or by any other means as directed by BHEL Engineer. Cost of such protections shall be deemed to be included in the rates quoted for the item.

### 10.11 CLEARANCE OF SITE AND REPAIRS.

10.11.1 Contractor has to clear the site / area where mechanical / storage and electrical erection work is to be commenced / or in progress. The contractor shall remove construction materials and equipment lying in the vicinity and causing obstruction in the erection work within 24 hrs. notice, In case he fails to clear the site, this will be done at his risk & cost by BHEL.

### 10.12 QUALITY ASSURANCE

10.12.1 The contractor has to establish / arrange at site the field testing facilities for testing of civil construction materials and concrete cubes for ensuring the proper quality, grade and strength of the materials used in the construction in line with approved field quality check list/ relevant IS Code specifications as specified by BHEL Engineer. Contractor has to submit detailed report for testing of all material used etc. All testing shall be done as per IS code specifications/ BHEL's quality plan. If further test is required by the engineer to be carried from outside laboratory, the cost of the same shall be borne by the contractor.

### 10.13 COMPLETION OF WORK

10.13.1 The works shall be completed to the entire satisfaction of the BHEL Engineer and in accordance with the completion schedule as specified in the Contract, and all unused stores and materials, tools, plant, equipment, temporary buildings, site office, labour hutments and other things shall be removed and the site and work cleared of rubbish and all waste materials and delivered up clean and tidy to the satisfaction of the BHEL Engineer at the Contractor's expenses.

10.13.2 BHEL shall have power to take over from the Contractor from time to time such sections of the work as have been completed to the satisfaction of the BHEL Engineer. Such work however shall not be treated as have been completed until the extra works are executed to the satisfaction of BHEL Engineer.

### 10.14 COMMENCEMENT OF GUARANTEE PERIOD

10.14.1 The Guarantee period shall commence only after completion & handing over of the entire works. The BHEL Engineer shall certify to the contractor the date on which the work is completed & handed over and the date thereof for commencement of Guarantee Period. The duration of Guarantee Period shall be as per GCC.

# TECHNICAL CONDITIONS OF CONTRACT (TCC)

## Chapter-X: Other Important Conditions

---

### 10.15 **METHOD OF MEASUREMENT**

10.15.1 Method of measurements if not specified in the tender, shall be as per relevant IS Codes / CPWD codes.

### 10.16 **HSE& OHSAS:**

10.16.1 The contractor shall comply with the requirements / stipulations of Chapter-IX of SCC towards Health, Safety and Environment.

### 10.17 **DISCREPANCIES AND ADJUSTMENT OF ERRORS:**

10.17.1 The several documents forming the Contract are to be taken as mutually explanatory of one another, detailed drawings being followed in preference to small scale drawings and figures dimensions in preference to scale and special conditions in preference to general conditions.

10.17.2 If there are varying or conflicting provisions made in any one document forming part of the contract, the BHEL Engineer shall be the deciding authority with regard to the document.

10.17.3 Any error in description, quantity in schedule of quantities or any omission therefrom shall not vitiate the contract or release the contractor from the execution of the whole or any part of the works comprised therein according to the drawings and specifications or from any of his obligations under the contract.

TECHNICAL CONDITIONS OF CONTRACT (TCC)  
Chapter-XI: Annexures

---

**Annexure – I** : Rate Schedule

**Annexure – II** : BOQ cum Rate schedule for the Work of “**Geotechnical Investigation and Topographical Survey for 1X660 MW PANKI THERMAL POWER STATION, KANPUR, U.P.**”

**TECHNICAL CONDITIONS OF CONTRACT (TCC)**  
**Chapter-XI: Annexures**

Annexure - I

<b><u>RATE SCHEDULE</u></b>		
Job-: "GEOTECHNICAL INVESTIGATION AND TOPOGRAPHICAL SURVEY FOR 1X660 MW PANKI THERMAL POWER STATION, KANPUR, U.P."		
<b>Sl. No.</b>	<b>DESCRIPTION OF WORK</b>	<b>TOTAL PRICE ("A") IN RUPEES (IN FIGURES AND WORDS)</b>
1.0	TOTAL PRICE ("A") FOR THE TOTAL WORK AS PER TENDER SPECIFICATION FOR "GEOTECHNICAL INVESTIGATION AND TOPOGRAPHICAL SURVEY FOR 1X660 MW PANKI THERMAL POWER STATION, KANPUR, U.P."	In Figures: _____ _____ In Words: _____ _____ _____
Notes:-		
<ul style="list-style-type: none"> <li>• The rates of different items for the entire scope of work shall be as per BOQ Cum Rate schedule ("Annexure-II") of TCC.</li> <li>• The derived item rate will remain firm through out the Contract period.</li> </ul>		

# TECHNICAL CONDITIONS OF CONTRACT (TCC)

## Chapter-XI: Annexures

### Annexure - II

<b>BOQ cum Rate Schedule</b>						
<b>Project: 1X660 MW PANKI THERMAL POWER STATION, KANPUR, U.P.</b>						
<b>Name of Work: Geotechnical Investigation and Topographical Survey for 1X660 MW PANKI THERMAL POWER STATION, KANPUR, U.P.</b>						
SL. No.	Item Description	UNIT	QTY.	FACTOR (F)	RATE (Rs.) = FACTOR (F) * A / 1000 (Rounded off to two place after decimal)	AMOUNT (Rs.) = RATE *QTY
1	Mobilisation of necessary equipments, men and materials to the project site for carrying out the geotechnical investigation and demobilisation of the same after completion of all the field works etc all complete as per specification, drawings and as directed by the engineer-in-charge.	LS	1	50.620		
2	Making 150mm nominal diameter bore hole up to a maximum depth of 50 m below ground level at various locations in all types of soil including laterite using suitable approved method of boring including chiselling, cleaning, providing casing pipes as required or as directed; performing standard penetration test at every 1.0 m interval alternate to collection of undisturbed soil samples up to 5m depth below ground level and at every 1.5m interval alternate to collection of undisturbed soil samples beyond 5 m depth, at change of strata and at depths wherever undisturbed soil samples could not be collected; collection of undisturbed sample (JDS) at every 1.0m interval alternate to conducting standard penetration test up to 5 m depth below ground level and at every 1.5m interval alternate to conducting standard penetration test beyond 5 m depth; collection of disturbed soil samples and water samples, sealing and packing of samples, observation such as ground water table etc; transportation of all the collected samples to the laboratory and back filling of boreholes with sand on completion of the same etc all complete as per specification and as directed by the engineer-in-charge.	M	4500	0.102		

# TECHNICAL CONDITIONS OF CONTRACT (TCC)

## Chapter-XI: Annexures

3	Excavating trial pit of size 3m x 3m at various locations upto a maximum depth of 4m below ground level in all types of soil/rock which can be excavated with pick axe/crow bar etc including sheeting or shoring the sides for the purpose of stability, dewatering and maintaining the pit dry at all times, collecting disturbed/undisturbed samples and conducting field density test at 1m interval, starting from 1m depth below ground level and transporting all the collected samples to the laboratory; backfilling of the pit with excavated material etc all complete as per specification and as directed by the engineer-in-charge.	CuM	710	0.033		
4	Conducting plate load test in various locations at specified depth below ground level complete as per specification, drawings and as directed by the engineer-in-charge. Payment for making the pit of suitable size, maintaining it dry and backfilling etc shall be paid separately as per item no. 3.	Each	12	2.476		
5	Conducting cyclic plate load test in various locations at specified depth below ground level complete as per specification, drawings and as directed by the engineer-in-charge. Payment for making the pit of suitable size, maintaining it dry and backfilling etc shall be paid separately as per item no. 3.	Each	5	2.671		
6	Conducting cross hole shear wave test in bore hole in all types of strata at 2m, 4m, 6m, 8m, 10m, 12m, 15m, 18m, 20m, 23m, 26m, 30m, 35m & 40m depth below ground level including drilling and preparation of required number of bore holes, providing PVC liner, grouting and backfilling with sand after completion of the test etc all complete as per specification, drawings and as directed by the engineer-in-charge.	Each	3	21.463		
7	Conducting pump in type field permeability test by constant head or falling head method (suitability of type of test shall be as per site conditions) in various boreholes at specified depth including providing packers as required etc. all complete as per specification, drawings and as directed by the engineer-in-charge. Cost of the borehole and backfilling etc. shall be paid separately as per item no.2.	Each	20	1.044		
8	Conducting field vane shear test in various locations at required depth below ground level including collection of disturbed soil sample etc all complete as per specification, drawings and as directed by the engineer-in-charge	Each	20	0.428		

# TECHNICAL CONDITIONS OF CONTRACT (TCC)

## Chapter-XI: Annexures

9	Performing Static cone penetration test at various locations all complete as per specification, drawings and as directed by the engineer-in-charge.	Each	15	2.376		
10	Performing dynamic cone penetration test at various locations using 65mm cone with circulation of bentonite slurry etc all complete as per specification, drawings and as directed by the engineer-in-charge.	Each	15	0.448		
11	Conducting electrical resistivity test at various locations complete as per specification, drawings and as directed by the engineer-in-charge.	Each	38	0.453		
12	Conducting pressure meter test in bore hole at 1m, 3m, 5m, 7m, 9m, 12m, 15m, 18m, 21m, 24, 27m, 30m, 35m & 40m depth below ground level in all type of strata including drilling and preparation of bore hole of required size etc all complete as per specification, drawings and as directed by the engineer-in-charge.	Each	2	22.524		
13	Conducting percolation test at specified depth below ground level in trial pit complete as per IS2470 (part 2)-1985, drawings and as directed by the engineer-in-charge. Payment for making the pit of suitable size, maintaining it dry and backfilling etc shall be paid separately as per item no.3.	Each	7	0.863		
14	Conducting block vibration test in various locations at specified depth including laying of plain cement concrete block of size 1.5mx0.75mx0.7m using M-15 grade concrete, all complete as per IS: 5249, and as directed by the engineer-in-charge. Payment for making the pit of size 4.5mx2.75m, maintaining it dry and backfilling etc shall be paid separately as per item no. 3.	Each	2	10.457		
15	Conducting seismic refraction test at various locations complete as per specification, drawings and as directed by the engineer-in-charge.	RM	900	0.034		
16	Conducting field CBR test in various locations at specified depth below ground level complete as per specification, drawings and as directed by engineer-in-charge.	Each	10	0.904		
17	Conducting laboratory test on soil samples at an approved laboratory including preparation of soil samples to determine the following properties etc all complete as per specification.			-		
a	Bulk density and moisture content	Each	260	0.008		
b	Sieve analysis	Each	520	0.006		
c	Hydrometer analysis	Each	130	0.009		

**TECHNICAL CONDITIONS OF CONTRACT (TCC)**  
**Chapter-XI: Annexures**

d	Liquid limit and plastic limit	Each	520	0.009		
e	Shrinkage limit	Each	30	0.009		
f	Specific gravity	Each	130	0.010		
g	Swell pressure	Each	20	0.022		
h	Free swell index	Each	20	0.027		
i	Relative density	Each	20	0.039		
j	Unconfined compressive strength on undisturbed sample	Each	200	0.024		
k	Direct shear test	Each	20	0.027		
l	Triaxial shear test			-		
i)	unconsolidated undrained test	Each	10	0.024		
ii)	consolidated undrained test	Each	10	0.066		
iii)	consolidated drained test	Each	10	0.066		
m	One dimensional consolidation test	Each	20	0.065		
n	Standard Proctor compaction test	Each	20	0.131		
o	Modified proctor compaction test	Each	20	0.281		
p	CBR test	Each	10	0.134		
q	Permeability test	Each	10	0.004		
r	Chemical analysis	Each	10	0.091		
s	Chemical analysis to determine SO <sub>3</sub> in 2:1, water: soil extract	Each	5	0.089		
18	Conducting chemical test on water samples to determine the carbonate, sulphate, chloride and nitrate contents, pH value, turbidity, organic matter and any other chemicals harmful to foundation material etc all complete as per specification.	Each	10	0.218		
19	Preparation and submission of draft report in 3 copies and final report in 5 hard copies and 2 soft copies on CD after the approval of draft report including all field records, laboratory test results, graphs, analysis of test results, photo graphs showing details of field tests/soil/rock samples/Trail pits and recommendation etc all complete as per specification.	LS	1	9.792		

# TECHNICAL CONDITIONS OF CONTRACT (TCC)

## Chapter-XI: Annexures

<b>Topographical Survey</b>						
1	Carrying out bench mark from the nearest GTS bench mark or any other available source as approved by the engineer-in-charge to different locations in the project area including clearing of jungles and/or cutting trees and any other works required for completion of the said item etc all complete as per specification and instructions of the engineer-in-charge. (Construction of bench mark pillar to be paid separately)	km	5	0.496		
2	Carrying out topographical survey of plant and allied areas showing all permanent & general features and detailed contour survey by taking spot levels at 5m interval, carrying out cross section of canal/nallah by taking spot levels at 5m interval or less including clearance of jungles and cutting of trees etc which are interfering with the survey works and any other field works necessary for the completion of the said item, preparation and submission of all plans (maps), reports, floppy and originals etc all complete as per specification and instructions of the engineer-in-charge.	Hectare	210	0.404		
3	Construction of bench mark pillar/reference pillar/grid pillar at different locations including clearing of jungles, excavation, supply of materials, pillar marking, backfilling, white washing, painting on MS plate etc all complete as per specification, drawings and instructions of the engineer-in-charge.					
	a) Bench mark pillar	Each	4	0.923		
	b) Grid/reference pillar	Each	50	0.446		
	<b>Total Amount (Rs.)</b>	<b>'A'</b>				

**NOTES:**

1	Bidder's quoted price above shall be complete in all respect for the full scope defined in specification and in accordance with all terms & conditions of tender.
2	Contractor shall fully understand description and Specifications of items mentioned in BOQ.
3	Conditional price bids with any deviation / clarification etc. are liable to be rejected. No cutting / erasing / over writing shall be done.
4	Quantities mentioned in rate schedules are approximate only and liable for variation on either side depending upon site / design requirement. The tentative contract value (CV) of entire scope of work shall be calculated as per finally quoted / accepted rates & the Quantities indicated in BOQ cum Rate Schedule .
5	Contractor's total quoted price as per rate schedule will be taken as tentative only. The contractor undertakes to execute actual quantities as per advice of BHEL Engineer and accordingly the final contract price shall be worked out on the basis of quantities actually executed at site and payments will also be regulated for the same.
6	In case of any mis-match in rate and amount on price discrepancy, the same will be dealt as per clause no. 1.4 of GCC.

# TECHNICAL CONDITIONS OF CONTRACT (TCC)

## Part-II: Technical Specifications

---

Following Documents are attached as Part-II: Technical Specifications of Technical Conditions of Contract (Volume-IA: TCC)

<b>Sl. No.</b>	<b>Description</b>	<b>Document No.</b>	<b>No. of Sheets</b>
1	Standard Specifications for Geotechnical Investigation	Specification No. PE-TS-999-603-002	51
2	Technical Specification for Topographical Survey	Specification No. PE-DC-K57-601-C001 Vol. II	12
3	Tender Drawing- Topographical Survey & Geotechnical Investigation Layout	PE-DG-K57-601-C001	1

**BHARAT HEAVY ELECTRICALS LTD**

**STANDARD SPECIFICATION  
FOR  
GEOTECHNICAL INVESTIGATION**

**SPECIFICATION NO. PE-TS-999-603-002**

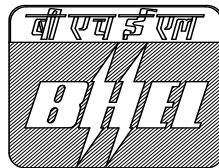

**JUNE, 2009**

**POWER SECTOR  
PROJECT ENGINEERING MANAGEMENT  
PPEI BUILDING, PLOT NO. 25  
SECTOR-16A  
NOIDA (U.P.)-201301**



STANDARD SPECIFICATION  
FOR  
GEOTECHNICAL INVESTIGATION

SPEC. NO. PE-TS 999-603-002

VOLUME II

SECTION D

REV. NO. 0 DATE 11.06.2009

SHEET 1 OF 50

**STANDARD SPECIFICATION  
FOR  
GEOTECHNICAL INVESTIGATION**

**1.0 GENERAL**

1.1 This specification covers the technical requirements for a detailed “geotechnical investigation and submission of a detailed geotechnical report”. The detailed geotechnical investigation shall be carried out onshore to provide the designer with sufficiently accurate information both general and specific about the sub-strata profile and relevant soil and rock parameters at site on the basis of which the foundation for various structures and equipments of the power station can be designed rationally. Such structures would include main power house, chimney, boiler foundation, turbo-generator foundation, foundation for vibratory equipments, deep pits, reservoir, ash pond, pipe supports and all other related structures of the power station etc. The above list is indicative and not exhaustive. The range of load intensities from the various structures are expected to be between 50 kN/sqm and 500 kN/sqm.

**2.0 SCOPE**

2.1 The work shall include mobilization of all necessary equipments, providing necessary engineering supervision and technical personnel, skilled and unskilled labours, arranging water for drilling etc as required to carry out the entire field as well as laboratory investigation, analysis and interpretation of test data collected and preparation of a geotechnical report. The entire field as well as laboratory investigation work shall be supervised by a graduate/post graduate in civil engineering with atleast 5 years of site experience in respective areas of geotechnical investigation work. A geologist shall also be deputed at site during investigation whenever rock drilling is undertaken. The scheduling of laboratory tests, analysis and interpretation of test results, drafting of report and recommendations shall be carried out by a post graduate in geotechnical engineering with atleast 5 years of experience.



STANDARD SPECIFICATION  
FOR  
GEOTECHNICAL INVESTIGATION

SPEC. NO. PE-TS 999-603-002

VOLUME II

SECTION D

REV. NO. 0 DATE 11.06.2009

SHEET 2 OF 50

- 2.2 The contractor shall make his own arrangements for locating the coordinates and position of bore holes, trial pits and other field tests as per the drawings/sketches supplied to him and for determining the reduced levels at these locations with respect to a single bench mark indicated by the engineer-in-charge. Two established reference lines will be indicated to him. The contractor has to provide at the site all the required survey instruments to the satisfaction of the engineer-in-charge so that the work can be carried out accurately according to the specification and drawings.
- 2.3 All the field data shall be recorded in the proforma recommended in Indian Standard Codes and the field records shall be countersigned by the engineer-in-charge. The contractor shall submit two copies of the field borelogs to the engineer-in-charge soon after the completion of each bore hole. All the investigations are to be carried out by the contractor as per the priority requirements of the engineer-in-charge.
- 2.4 The contractor shall intimate the engineer-in-charge giving reasons if any additional specific tests he consider necessary to be carried out duly considering local sub-soil conditions. In case the proposal for conducting additional specific tests is approved by the engineer-in-charge then same shall also be carried out.
- 2.5 Whenever the contractor is unable to extract undisturbed samples he should immediately inform the engineer-in-charge. In such a case payment for boring charges shall be subject to the engineer-in-charge being satisfied that adequate effort has been made to extract undisturbed samples.
- 2.6 All the laboratory test data shall be recorded in the proforma recommended in the Indian Standard Codes and a copy of these shall be sent to the engineer-in-charge every week during the progress of laboratory testing. Whenever desired during the progress of work the owner/engineer-in-charge may be present at the laboratory where the contractor is arranging for execution of the laboratory tests.
- 2.7 The contractor shall interact with the engineer-in-charge to get acquainted with the different type of structures envisaged and in assessing the load intensities on the foundation for the various structures of the power project in order to enable him/her to make



STANDARD SPECIFICATION  
FOR  
GEOTECHNICAL INVESTIGATION

SPEC. NO. PE-TS 999-603-002

VOLUME II

SECTION D

REV. NO. 0 DATE 11.06.2009

SHEET 3 OF 50

specific recommendation for the depth & type of foundation and the allowable bearing pressure. The contractor shall submit detailed geotechnical report after incorporating the comments (if any) on the draft report.

- 2.8 The “Standard Specification for Geotechnical Investigation” shall be read in conjunction with the document titled “Schedule of Quantities for Geotechnical Investigation” and amendments (if any) which shall be furnished specific project wise separately.

### 3.0 TENDER DRAWING

- 3.1 A tender drawing titled “Vicinity Map” or “Plot Plan” or “Geotechnical Investigation Layout” indicating the study area/tentative location of the bore holes and field tests/areas to be investigated for locating the project shall be furnished specific project wise separately. The location, extent and depth of bore holes and field tests/area(s) indicated in the drawing are subject to change that may be necessary during actual execution of the work. No claim whatsoever shall be entertained for differences between the location, extent and depth/area(s) etc of tests indicated on the construction drawings and those shown on the tender drawings. The work shall be carried out as per the instructions of the engineer-in-charge.

- 3.2 The bidder must visit the site prior to submitting his/her quotations to acquaint himself/herself fully with the nature, type, scope of work and involvement therein. The rates quoted shall remain firm during the entire period of execution till completion of the work and any additional claim for lack of knowledge shall not be entertained.

### 4.0 GENERAL REQUIREMENTS

- 4.1 In areas which have already been developed, the contractor shall take advantage of existing local knowledge, record of trial pits, bore holes etc in the vicinity and the type of foundations adopted and behaviour of existing structures particularly those of similar nature to the ones proposed for this project.
- 4.2 The contractor shall make use of information gathered from quarries, unlined wells, cuttings from nearby areas etc. The general



STANDARD SPECIFICATION  
FOR  
GEOTECHNICAL INVESTIGATION

SPEC. NO. PE-TS 999-603-002

VOLUME II

SECTION D

REV. NO. 0 DATE 11.06.2009

SHEET 4 OF 50

topography of the near by areas will often give some indication about the variation of the soil conditions which are likely to exist.

4.3 The contractor shall gather data regarding the removal of overburden by excavation, erosion or land slides in the areas which may give an idea of the amount of reconsolidation that the soil strata has undergone. Similarly data regarding recent fills shall also be studied to determine the characteristics of the fill as well as the original strata.

4.4 The water level in streams and water courses if any in the neighbourhood shall be noted. Reliable information regarding ground water level shall also be gathered from water level in the near by wells.

4.5 The contractor shall make enquiries and verify regarding earlier use of the site which can have important bearing on its suitability for the proposed structures. This is important particularly in areas where there have been underground works e.g. worked out ballast pits, quarries, old brick fields, mines, mineral workings etc. The possibility of damage to the structures, sewers, conduits and drainage system by subsidence shall also be investigated.

4.6 It is essential that the equipments/instruments are properly calibrated at the commencement of the work so that they represent true values and submit the test reports to the engineer-in-charge. If the engineer-in-charge so desires, the contractor shall arrange for having the instruments tested in presence of the engineer at an approved laboratory at the contractor's cost and the test reports shall be submitted to the engineer-in-charge.

4.7 When blasting with explosives is involved, agency/contractor shall arrange statutory clearances and also the portable magazine for storing/carrying the explosives.

## 5.0 CODES AND STANDARDS

5.1 All standards, specification and codes of practice referred to herein shall be the latest editions including all applicable official amendments and revisions.



STANDARD SPECIFICATION  
FOR  
GEOTECHNICAL INVESTIGATION

SPEC. NO. PE-TS 999-603-002

VOLUME II

SECTION D

REV. NO. 0 DATE 11.06.2009

SHEET 5 OF 50

5.2 In case of conflict between this specification and those (IS codes and standards etc) referred to herein, the former shall prevail.

5.3 All work shall be carried out as per the specification and the following standards and codes.

IS: 1080 Code of practice for design and construction of simple spread foundations

IS: 1498 Classification and identification of soils for general engineering purposes

IS: 1888 Method of load test on soils

IS: 1892 Code of practice for subsurface Investigation for foundation

IS: 1904 Code of practice for design and construction of foundations in soils: General requirements

IS: 2131 Method of standard penetration test for soils

IS: 2132 Code of practice for thin walled tube sampling of soils

IS: 2470 Code of practice for design and construction of septic tanks Part-I

IS: 2720 Method of test for soils (Relevant parts)

IS: 2809 Glossary of terms and symbols relating to soil engineering

IS: 2810 Glossary of terms relating to soil dynamics

IS: 2911 Code of practice for design and construction of pile foundations (Relevant parts)

IS: 2950 Code of practice for design and construction of raft foundation Part- I



STANDARD SPECIFICATION  
FOR  
GEOTECHNICAL INVESTIGATION

SPEC. NO. PE-TS 999-603-002

VOLUME II

SECTION D

REV. NO. 0 DATE 11.06.2009

SHEET 6 OF 50

- IS: 3025 Methods of sampling and testing (Physical and chemical) for water used in Industry
- IS: 3043 Code of practice for earthing
- IS: 4078 Code of practice for indexing and storage of drill cores
- IS: 4434 Code of practice for in-situ vane shear test for soils
- IS: 4453 Code of practice for exploration by pits, trenches, drifts and shafts
- IS: 4464 Code of practice for presentation of drilling information and core description in foundation investigation
- IS: 4968 Method for subsurface sounding for soils- Dynamic Part -II method using cone and bentonite slurry
- IS: 4968 Method for subsurface sounding for soils-Static cone Part-III penetration test
- IS: 5249 Method of test for determination of in-situ dynamic properties of soil
- IS: 5313 Guide for core drilling observations
- IS: 5529 Code of practice for in-situ permeability test – Test in Part-I overburden
- IS: 5529 Code of practice for in-situ permeability test - Test in bed Part-II rock
- IS: 6065 Recommendation for the preparation of geological and geotechnical maps for river valley project
- IS: 6403 Code of practice for determination of allowable bearing pressure on shallow foundation
- IS: 6926 Code of practice for diamond core drilling for site investigation of river valley projects



STANDARD SPECIFICATION  
FOR  
GEOTECHNICAL INVESTIGATION

SPEC. NO. PE-TS 999-603-002

VOLUME II

SECTION D

REV. NO. 0 DATE 11.06.2009

SHEET 7 OF 50

- IS: 6935 Method of determination of water level in a bore hole
- IS: 6955 Code of practice of subsurface exploration for earth and rockfill dams
- IS: 7422 Symbols and abbreviations for use in geological maps, sections and subsurface exploratory logs (Relevant parts)
- IS: 8009 Code of practice for calculation of settlement of  
Part-I foundation subjected to symmetrical vertical loads -  
Shallow foundations
- IS: 8009 Code of practice for calculation of settlement of  
Part-II foundation subjected to symmetrical vertical loads –  
Deep foundations
- IS: 8763 Guide for undisturbed sampling of sands
- IS: 8764 Method for determination of point load strength index of rocks
- IS: 9143 Method for the determination of unconfined compressive strength of rock materials
- IS: 9179 Method for preparation of rock specimen for laboratory testing
- IS: 9198 Compaction rammer for soil testing
- IS: 9214 Determination of modulus of sub-grade reaction in field
- IS: 9259 Specifications for liquid limit apparatus
- IS: 9640 Specifications for split spoon sampler
- IS: 9669 Specifications for CBR mould and its accessories
- IS: 10050 Method for determination of slake durability index of rocks



STANDARD SPECIFICATION  
FOR  
GEOTECHNICAL INVESTIGATION

SPEC. NO. PE-TS 999-603-002

VOLUME II

SECTION D

REV. NO. 0 DATE 11.06.2009

SHEET 8 OF 50

IS: 10060 Code of practice for subsurface investigation for power house sites

IS: 10074 Specification for compaction mould assembly for light and heavy compaction

IS: 10108 Code of practice for sampling by thin wall sampler with stationary piston

IS: 10589 Equipment for determination of subsurface sounding of soils

IS: 10837 Specifications of moulds for determination of relative density and its accessories

IS: 11229 Specifications for shear box testing of soils

IS: 11315 Description of discontinuities in rock mass - Core Part-II recovery and rock quality

IS: 12070 Code of practice for design and construction of shallow foundations on rocks

IS:13372 Seismic testing of rock mass – Code of practice (Part I & II)

## **6.0 FIELD INVESTIGATION - SOIL**

### **6.1 Boring**

#### **6.1.1 General Requirements**

a) Bore holes shall be drilled at specified locations to obtain information about the sub-soil profile, its nature, strength and to collect soil samples for strata identification and conducting laboratory tests. The minimum diameter of the bore hole shall be 150 mm and boring shall be carried out in accordance with the provisions of IS: 1892 and as per this specification.



STANDARD SPECIFICATION  
FOR  
GEOTECHNICAL INVESTIGATION

SPEC. NO. PE-TS 999-603-002

VOLUME II

SECTION D

REV. NO. 0 DATE 11.06.2009

SHEET 9 OF 50

b) All bore holes shall extend up to the depths shown on the construction drawings or as directed by the engineer-in-charge. If the strata with standard penetration test (SPT) 'N' value greater than 100 with characteristics of rock is met with earlier, the bore hole shall be advanced further by chiselling. Chiselling shall be continued for a maximum depth of 20cm or upto 2 hours whichever is earlier. During chiselling rock fragments/rock cores shall be collected. Identification of rock strata shall be on the basis of visual examination of SPT sample and rock fragments. After it is established that rock is met with, the borehole shall be advanced further by drilling in rock as specified in Clause-7.0 and cores shall be collected. When the bore hole is terminated in soil strata, an additional standard penetration test shall be carried out at the termination depth.

c) Casing pipe shall be used in the borehole to support its sides when side fall is suspected to occur inside the borehole. When casing pipe is used, it shall be ensured that its bottom end is at all times 15 cm above the bottom of the bore hole. In case of cohesionless soils the advancement of the casing pipe shall be such that it does not disturb the soil to be tested or sampled. The casing shall be advanced by slowly turning the casing pipe and not by driving.

d) In-situ tests and collection of undisturbed samples (UDS) shall be carried out at regular intervals and at change of strata or as decided by the engineer-in-charge. Representative disturbed and undisturbed samples shall be preserved for conducting various tests in the laboratory. Water table in the borehole shall be carefully recorded and reported. No water/drilling mud shall be added while boring above ground water table. For cohesionless soil below water table, the water level in the borehole shall all times be maintained at slightly above the water table.

e) The bore hole shall be cleaned using suitable tools up to the depth of testing or sampling ensuring that there is minimum disturbance of soil at the bottom of the bore hole. The process of jetting through an open tube sampler shall not be permitted. In cohesive soils, the borehole may be cleaned using a bailer with a flap valve. Gentle circulation of drilling fluid shall be done when rotary mud circulation boring is adopted.



STANDARD SPECIFICATION  
FOR  
GEOTECHNICAL INVESTIGATION

SPEC. NO. PE-TS 999-603-002

VOLUME II

SECTION D

REV. NO. 0 DATE 11.06.2009

SHEET 10 OF 50

f) On completion of the borehole, the portion drilled in soil shall be backfilled with sand unless otherwise specified and as directed by the engineer-in-charge.

g) Wash boring shall not be adopted.

### 6.1.2 Auger Boring

Auger boring can be adopted in soft to stiff cohesive soils above water table. Augers shall be of helical or post hole type which may be manually or power operated. While boring care shall be taken to minimise the disturbance to the deposits below the bottom of the borehole. The cuttings brought up by the auger shall be carefully examined in the field and the description of all the strata shall be duly recorded in the field borelog as per IS:1498. No water shall be used while auger boring.

### 6.1.3 Shell and Auger Boring

Shell and Auger boring can be used in all types of soil free from boulders. For cohesionless soil below ground water table, the water level in the bore hole shall always be maintained at or above the ground water level. The use of chisel bit shall be permitted in hard strata with SPT 'N' value greater than 100. Chisel bits may also be used to extend the borehole through local obstruction such as old construction, boulders, rocky formations etc. All other requirements in clause 6.1.2 shall apply for this type of boring also.

### 6.1.4 Percussion Drilling

This method can be adopted in soil with gravel and boulders when the boring has to be done at a faster rate. This method consists of breaking of the strata by repeated blows from a chisel or drilling bit and bailing out the debris at intervals by adding water into the bore hole. This method is not suitable for careful and very reliable sampling operation because of the disturbance caused during boring. This method shall not be adopted unless otherwise specified or permitted by the engineer-in-charge.



STANDARD SPECIFICATION  
FOR  
GEOTECHNICAL INVESTIGATION

SPEC. NO. PE-TS 999-603-002

VOLUME II

SECTION D

REV. NO. 0 DATE 11.06.2009

SHEET 11 OF 50

### 6.1.5 Rotary Mud Circulation Drilling

This method can be used in all types of soil below water table. In this method boring shall be done by rotating the bit fixed at the bottom of the drill rod. Proper care shall be taken to keep a firm contact between the bit and the bottom of the borehole. Bentonite or mud laden fluids shall be used as the drilling fluid to serve as the protective surface inside the borehole.

### 6.2 Standard Penetration Test (SPT)

This test shall be conducted in all types of soil deposits met within the bore hole to find the variation in the soil stratification by correlating with the number of blows required for unit penetration of a standard penetrometer. This test shall be conducted at every 1m interval alternate to collection of UDS upto 10m depth below ground level and at every 1.5m interval alternate to collection of UDS beyond 10m depth, at every change of strata, at depths wherever undisturbed soil samples could not be collected and as per the directions of the engineer-in-charge. The starting depth of performing SPT shall be 1m below ground level unless otherwise specified. The depth interval between the top level of standard penetration test and to that of (next) undisturbed sampling shall not be less than 1m. The specification for equipments and other accessories, procedure for conducting the test, presentation of test results and collection of disturbed soil samples etc shall conform to IS: 2131.

This test shall be carried out by driving a standard split spoon sampler in the borehole by means of a 63.5 kg hammer having a free fall of 0.75m. The sampler shall be driven using the hammer for 450 mm penetration. While driving, the number of blows for every 150 mm penetration and the penetration for every 50 blows shall be recorded. The number of blows for the last 300 mm drive shall be reported as 'N' value. This test shall be discontinued when the blow count is equal to 100 and the penetration shall be recorded. Refusal shall be considered to be met with when the blow count is equal to 100. At the location where the test is discontinued, the penetration and the corresponding number of blows shall be reported. Sufficient quantity of disturbed soil samples shall be collected from the split spoon



STANDARD SPECIFICATION  
FOR  
GEOTECHNICAL INVESTIGATION

SPEC. NO. PE-TS 999-603-002

VOLUME II

SECTION D

REV. NO. 0 DATE 11.06.2009

SHEET 12 OF 50

sampler for identification and laboratory testing. The samples shall be visually classified & recorded at the site and shall be properly preserved and labelled for future identification & testing.

### 6.3 Sampling

#### 6.3.1 General

a) Sufficient number of soil samples shall be collected for reliable estimation of soil properties. The samples collected shall be either disturbed or undisturbed. Disturbed soil samples shall be collected for field identification and conducting laboratory tests such as sieve analysis, index properties, specific gravity, chemical analysis etc. Undisturbed samples shall be collected to estimate physical, strength and settlement properties of the soil.

b) All the accessories required for sampling and the method of sampling shall conform to IS:2132. All disturbed and undisturbed samples collected in the field shall be classified at site as per IS: 1498.

c) All the samples shall be identified with date, bore hole or trial pit number, depth of sampling etc. It is also essential to mark an arrow pointing towards the top surface of the undisturbed sample as the soil was in-situ. Care shall be taken to keep the undisturbed soil samples and box samples vertically with the arrow directing upwards. The tube samples shall be properly trimmed at both ends and suitably sealed with molten paraffin wax at both ends immediately after extracting the samples from the bore hole/trial pit and suitably capped on both sides.

**d) When the contractor fails to collect undisturbed soil sample at a specified depth, the borehole shall be advanced by 0.50m and shall be performed with a standard penetration test. The reason for not obtaining the undisturbed soil sample shall be indicated in the borelog.**

e) Precaution shall be taken to ensure that there shall not be any change in moisture content and disturbance of the soil samples and they shall be placed in a temporary store at the end of the day's work.



STANDARD SPECIFICATION  
FOR  
GEOTECHNICAL INVESTIGATION

SPEC. NO. PE-TS 999-603-002

VOLUME II

SECTION D

REV. NO. 0 DATE 11.06.2009

SHEET 13 OF 50

All the samples shall be kept over a bed of sand, jute bags, saw dust etc and covered over the top with similar material. The bed and top cover shall be kept moist till they are properly packed in wooden boxes. The contractor shall be responsible for packing and transporting of all the samples from site to the laboratory within seven days after sampling with proper protection against loss and damage.

f) All the samples shall be suitably packed in wooden boxes using sand, saw dust etc all around the samples before transporting to the laboratory for testing.

### 6.3.2 Disturbed Samples

a) Disturbed soil samples shall be collected from cuttings and from split spoon sampler in boreholes at regular intervals to provide complete description of soil profile and its variation. The samples shall be immediately stored in airtight jars or polythene bags and labelled with borehole/trial pit number and depth.

b) In elevated areas, if superficial material is available in plenty, then bulk samples from a depth of about 0.5m below ground level shall be collected to establish all required properties to use it as a fill material. Disturbed samples weighing about 250N shall be collected at shallow depths and immediately stored in polythene bags as per IS: 1892. The bags shall be sealed properly and shall be kept in wooden boxes.

### 6.3.3 Undisturbed Samples

In each borehole UDS shall be collected at regular interval of 1m alternate to conducting SPT upto 10m depth below ground level and at every 1.5m interval alternate to conducting SPT beyond 10m depth and as directed by the engineer-in-charge. The starting depth of collecting UDS shall be 2m below ground level unless otherwise specified and as directed by the engineer-in-charge. Undisturbed samples shall be of 100mm diameter and 450mm length. Samples shall be collected in such a manner that the structure of soil and its moisture content do not get altered. The specification for the accessories required for sampling and the sampling procedure shall



STANDARD SPECIFICATION  
FOR  
GEOTECHNICAL INVESTIGATION

SPEC. NO. PE-TS 999-603-002

VOLUME II

SECTION D

REV. NO. 0 DATE 11.06.2009

SHEET 14 OF 50

conform to IS:1892 and IS:2132. Undisturbed sampling in sand shall be done using compressed air technique as mentioned in IS:8763. Thin walled sampler shall be used to collect undisturbed samples by pushing the tube into the soil. The sampling tube shall have a smooth finish on both surfaces and minimum effective length of 450mm. The area ratio of sampling tubes shall be less than 12.5%. However in case of very stiff soils area ratio upto 20% shall be permitted.

**a) Undisturbed Sampling in Cohesive Soil**

Undisturbed samples in soft to stiff cohesive soils shall be obtained using a thin walled sampler. In order to reduce wall friction, suitable precautions such as oiling the surfaces shall be taken. The bore hole shall be cleaned and the depth of sampling below ground level shall be noted. The sampler shall then be attached to the bottom of boring rods and lowered into the borehole. The sampler shall be pushed into the clay layer by hand or by jacking and soil sample of specified length shall be collected without disturbing the soil. The distance by which the sampler penetrates into the soil strata shall be checked. Care shall be taken to ensure that the sampler is not driven too far as this will compress the soil. The sampler shall be rotated to break the core at bottom of the sampler and then steadily drawn up.

**b) Undisturbed Sampling using Piston Sampler**

Undisturbed samples in very loose saturated sandy & silty soils and very soft clays shall be obtained by using a piston sampler consisting of a sampling cylinder and piston system. In soft clays and silty clays with water standing in the casing pipe, piston sampler shall be used to collect undisturbed samples. During this method of sampling expert supervision is called for.

The interior surface of the sampler shall be smooth, clean and corrosion resistant. Its cutting edge and the ring seals shall be inspected for wear and rejected if worn. Check shall be done to ensure that the moving parts of the sampler function freely before the sampler is lowered into the borehole. While pushing the system into the soil and till the beginning of the sampling operations, the bottom of the piston shall be flushed with the cutting edge of the sampler. At the depth of sampling, the piston should be fixed relative to the



STANDARD SPECIFICATION  
FOR  
GEOTECHNICAL INVESTIGATION

SPEC. NO. PE-TS 999-603-002

VOLUME II

SECTION D

REV. NO. 0 DATE 11.06.2009

SHEET 15 OF 50

ground and the sampler cylinder shall be independently pressed down smoothly and continuously into the ground. If an obstruction is met, the sampler shall be withdrawn and another sample be taken after the obstruction is removed.

Accurate measurements of the depth of sampling, height of sampler, stroke and length of sample recovery shall be noted and recorded. After the sampler is pushed to the required depth, both the sampler cylinder and the piston system shall be drawn up together ensuring that there shall not be any disturbance to the sample which shall then be protected from changes in moisture content.

**c) Undisturbed Sampling in Cohesionless Soils**

Undisturbed samples in cohesionless soils shall be obtained as per the procedure given in IS:8763. Compressed air sampler shall be used to take the samples of cohesionless soil below water table. Precautions shall be taken to clean the borehole before sampling. Thin walled tube samplers of 60mm internal diameter shall be used. The height and other dimensions of the sampler shall be recorded before use. Proper care shall be taken to maintain the water level in the bore hole slightly above the ground water table before and during sampling operations. Immediately after the sample is obtained, the ends of the sample shall be waxed and capped to avoid moisture content changes.

**6.3.4 Relaxation During Sampling**

a) The sampler shall be pushed into the soil and driving of sampler shall be resorted to only when it cannot be pushed into the soil. This shall be done only with the permission of the engineer-in-charge and all the details about the same shall be recorded in the bore logs.

b) In clays when 'N' value is greater than 50, the undisturbed sampling may be replaced by standard penetration test.



STANDARD SPECIFICATION  
FOR  
GEOTECHNICAL INVESTIGATION

SPEC. NO. PE-TS 999-603-002

VOLUME II

SECTION D

REV. NO. 0 DATE 11.06.2009

SHEET 16 OF 50

## 6.4 Ground Water

6.4.1 One of the following methods shall be adopted for determining the ground water table in bore holes as per IS:6935 and as per the instructions of the engineer-in-charge.

a) In permeable soils, the water level in borehole shall be allowed to stabilize after lowering it adequately by bailing. When water level inside the borehole is found to be stable, the depth of water level below ground level shall be measured. Stability of sides and bottom of the borehole shall be ensured at all times.

b) For both permeable and impermeable soils, the following method shall be suitable. The borehole shall be filled with water and then bailed out to various depths. Observation on the rise or fall of water level shall be made at each depth. The level at which neither a fall nor a rise is observed shall be considered as the water table elevation. This shall be established by three successive readings of water level taken at an interval of two hours.

6.4.2 In case any variation in the ground water level is observed in any specific boreholes then the water level in these bore holes shall be recorded daily during the course of field investigation. Levels in nearby wells, streams etc if any shall also be noted whenever these readings are taken. If so called for, observation wells shall be drilled for the purpose of long term studies on the fluctuation in ground water levels and pressure. Either stand pipe or piezometer shall be installed at the specified depths in the selected previously drilled bore holes or specially drilled bore holes for this purpose as per the specification and instructions of the engineer-in-charge. Daily water level readings shall be recorded immediately following the installation upto the time of leaving the site. At the end of field work, these installations shall be handed over in satisfactory working condition to the engineer-in-charge without disturbing their position so that the owner can continue further observations.

6.4.3 Stand pipes and piezometers shall consist of 19mm internal diameter rigid unplasticised (UPVC) tubing. All the joints in the tubing shall be made of coupling sleeves. The top of UPVC tubing shall be enclosed in a 75mm diameter galvanised steel pipe of 1.5m length



STANDARD SPECIFICATION  
FOR  
GEOTECHNICAL INVESTIGATION

SPEC. NO. PE-TS 999-603-002

VOLUME II

SECTION D

REV. NO. 0 DATE 11.06.2009

SHEET 17 OF 50

having a galvanised steel screw cap with well greased threads and the caps shall be tightened such that it would be impossible to loosen by hand. The lower end of the pipe shall have four legs of 6mm thick and 100mm long and welded to have projection of 25mm. The pipe shall be sealed into the ground with cement grout so that it does not rotate. The top end of the pipe shall project about 300mm above ground level unless otherwise specified by the engineer-in-charge. The perforated tubing for the porous element shall be surrounded by a response zone of well graded sand from 500mm below to 150mm above the lower end of the stand pipe or piezometer and the bore hole above the response zone shall be back filled with natural soil or well graded sand.

**a) Stand pipe**

Stand pipes shall be installed to measure the water level in soils with high permeability such as sand and gravel. The stand pipe shall consist of a perforated tubing attached to the bottom of the UPVC tubing. The perforated tube shall be 150mm long having perforations of diameter not greater than 1mm.

**b) Piezometers**

Piezometers shall be installed to measure the pore pressures in soil with medium to low permeability. Piezometer shall consist of a porous filter attached to the bottom of the UPVC tubing. The filter shall be 300mm in length and shall be placed in the bore hole and sealed at top and bottom by grouting. Hydraulic piezometers with double line are to be used to remove the air trapped in the system.

**6.4.4 Sub-Soil Water Samples**

a) Sub-soil water samples shall be collected for carrying out chemical analysis. Representative samples of ground water shall be collected when it is first encountered in boreholes before the addition of water to aid boring or drilling. Water samples shall not be collected when bentonite slurry or mud has been used for drilling operations. If water has been added for drilling purposes or if ground water has been diluted by surface rain water then the bore hole shall be



STANDARD SPECIFICATION  
FOR  
GEOTECHNICAL INVESTIGATION

SPEC. NO. PE-TS 999-603-002

VOLUME II

SECTION D

REV. NO. 0 DATE 11.06.2009

SHEET 18 OF 50

dewatered and water be allowed to rise from which the sample may be taken.

b) The sampling apparatus shall be such that the water at the desired depth can be collected directly without any disturbance and any change in concentration of constituents like dissolved gases etc. Undue agitation shall be avoided. An ordinary suction pump with its suction end inserted upto the required depth in the borehole shall be used for this purpose.

c) The sample shall be collected in a clean vessel and allowed to settle so that the supernatant liquid can be poured into a clean well rinsed glass or polythene bottle. Sufficient quantity and number of samples shall be collected to carry out the chemical analysis and sent to a laboratory in airtight bottles with proper labelling. Chemical analysis of water samples shall include determination of pH value, turbidity, sulphate, carbonate, nitrate & chloride contents, presence of organic matter and suspended solids etc.

d) In some cases constituents may be mixed and analysed later as specified in the specific test methods. Chemical preservatives may be added to the sample for cases as specified in the test method/IS codes. This shall only be done if analysis cannot be conducted within an hour of collection and shall have the prior written permission and approval of the engineer-in-charge.

## 6.5 In-situ Permeability Test

6.5.1 In-situ permeability test shall be conducted to determine the water percolation capacity of overburden soil. This test shall be performed inside the bore hole/trial pit at specified depths or in each layer or as per the directions of the engineer-in-charge. The type of test shall be either pump-in or pump-out test depending on the subsoil and ground water conditions. Pump-in test shall be conducted whether ground water in borehole exists or not. Pump-out test shall be conducted to obtain data for dewatering purposes when ground water is met in the borehole. The specification for equipments required for the test and the procedure of testing shall be in accordance with IS: 5529, Part-1. When it is required to carry out the permeability test for a particular section of the soil strata above ground water table, bentonite slurry shall not be used while boring.



STANDARD SPECIFICATION  
FOR  
GEOTECHNICAL INVESTIGATION

SPEC. NO. PE-TS 999-603-002

VOLUME II

SECTION D

REV. NO. 0 DATE 11.06.2009

SHEET 19 OF 50

## 6.5.2 Pump-in-Test

Pump-in test shall be conducted in the bore hole/trial pit by allowing water to percolate into the soil. Choice of the method of testing shall depend on the soil permeability and prevailing ground water level.

Only clear water shall be used for conducting the test. Before conducting the test, the borehole shall be cleaned as specified in clause 6.1.1 (e). Water shall be allowed to percolate through the test section for sufficient period of time to saturate the soil before starting the observation.

### a) Constant Head Method (In Bore Hole)

This test shall be conducted in boreholes where soil has a high permeability. Water shall be allowed into the borehole through a metering system ensuring gravity flow at constant head so as to maintain a steady water level in the borehole. A reference mark shall be made at a convenient level which can be easily seen in the casing pipe to note down the fluctuations of water level. The fluctuations shall be counteracted by varying the quantity of water flowing into the borehole. The elevation of water shall be observed at every 5 minute interval. When three consecutive readings show constant value, the necessary observations such as flow rate, elevation of water surface above test depth, diameter of casing pipe etc shall be made and recorded as per the proforma recommended in IS: 5529, Part-1, Appendix-A.

### b) Falling Head Method (In Bore Hole)

This method shall be adopted for soils of low permeability and which can stand without casing. The test section shall be sealed at the bottom of the borehole and a packer at the top of the test section. If the test has to be conducted at an intermediate section of a pre-bored hole then double packers shall be used. Access to the test section through the packer shall be by means of a pipe which shall extend above the ground level. Water shall be filled into the pipe upto the level marked just below the top of the pipe and water be allowed to drain into the test section. The water level in the pipe shall be



STANDARD SPECIFICATION  
FOR  
GEOTECHNICAL INVESTIGATION

SPEC. NO. PE-TS 999-603-002

VOLUME II

SECTION D

REV. NO. 0 DATE 11.06.2009

SHEET 20 OF 50

recorded at regular intervals as mentioned in IS: 5529, Part-1, Appendix-B. The test shall be repeated till constant records of water level are achieved.

### c) Percolation Test (In Trial Pit)

Percolation test shall be conducted in trial pit in areas where water/effluent is stored/discharged in ground level tanks. The loss of water due to percolation into the soil shall be estimated by the soil absorption capacity.

### 6.5.3 Pump-Out Test

This test shall be carried out at site to determine the co-efficient of permeability of soil below water table. This test shall be conducted by continuous pumping out of water from a well so as to maintain a steady water level at the desired depth in the well. The fluctuations in the water level shall be counteracted by varying the quantity of water pumped out of the well. The specification for the equipments & accessories required for performing the test, the procedure of testing, field observations and reporting of results shall conform to IS: 5529, Part-1. The well shall be of 400mm in diameter to be installed with a 250mm diameter perforated GI/MS pipe. Observation pipes of 50mm diameter shall be installed at regular intervals along three radial lines extending from the well at 120 degrees to each other. Length of these pipes shall depend upon the ground level, estimated depth of lowering the ground water and the distance from the well. Sufficient number of observation pipes shall be installed along each of the radial lines so as to assess the zones of influence due to dewatering. Draw down depth in the well shall be as specified in the drawing.

### 6.6 TRIAL PIT

6.6.1 Trial pits shall be of 3m x 3m size so as to permit easy access for visual examination of walls of the pit and to facilitate sampling and in-situ testing operations. Pits shall be excavated upto a maximum depth of 4m below ground level or as per the directions of the engineer-in-charge. Precautions shall be taken to ensure the stability of pit walls including provision of shoring if necessary as per IS:



STANDARD SPECIFICATION  
FOR  
GEOTECHNICAL INVESTIGATION

SPEC. NO. PE-TS 999-603-002

VOLUME II

SECTION D

REV. NO. 0 DATE 11.06.2009

SHEET 21 OF 50

4453. Precautions shall be taken to prevent surface water draining into the pit. Arrangements shall be made for dewatering if the pit is extended below water table. Trial pits shall be kept dry and a ladder shall be provided for easy access to the bottom of the pit. In-situ tests shall be conducted and undisturbed samples shall be collected immediately on reaching the specified depth so as to avoid substantial changes in moisture content of the subsoil. Arrangements shall be made for barriers, protective measures and lighting necessary for the period the pits remain open.

6.6.2 A note on the visual examination of soil strata shall be prepared. This should include the nature, colour, consistency and visual classification of the soil, thickness of soil strata, thickness of expansive soil & ground water table if any etc.

6.6.3 Undisturbed samples shall be collected at 1m, 2m, 3m depth and at the termination depth in all the pits.

**a) Chunk Samples**

In cohesive soils, undisturbed samples of regular shapes shall be collected. The samples shall be cut and trimmed to a size of 0.3m x 0.3m x 0.3m. A square area of 0.35m x 0.35m shall be marked at the centre of the levelled surface at the bottom of the pit. Without disturbing the soil inside the marked area, the soil around this marking shall be carefully removed upto a depth of 0.35m. The four vertical faces of the soil block protruding at the centre shall be trimmed slowly so that its size reduces to 0.3m x 0.3m. Wax paper cut to suitable size shall be wrapped uniformly and covered with two layers of thin cloth over all the five exposed surfaces of the soil block and sealed properly using molten wax. A firmly constructed wooden box of size 0.35m x 0.35m x 0.35m (internal dimensions) with the top and bottom open shall be placed around the soil block and held such that its top edge protrudes just above the surface of the block. The space between the soil block and the box shall be filled uniformly and tightly with moist saw dust. The top surface shall also be covered with saw dust before nailing the wooden lid to cover the box firmly taking care that the soil block is not disturbed. The area of contact between the bottom portion of the block and the ground shall be reduced slowly by removing soil in small quantities using



STANDARD SPECIFICATION  
FOR  
GEOTECHNICAL INVESTIGATION

SPEC. NO. PE-TS 999-603-002

VOLUME II

SECTION D

REV. NO. 0 DATE 11.06.2009

SHEET 22 OF 50

small rods so that the block can be separated from the ground slowly without disturbance. After inverting the wooden box along with the soil block, the bottom portion shall be trimmed and covered with wax paper, cloth and to be sealed with molten wax. A wooden lid shall be nailed to the box after providing proper saw dust cushion below it. An arrow mark shall be made on the vertical face of the wooden box to indicate the top surface of the sample along with the location, date and depth of sampling.

### b) Tube Samples

Undisturbed tube samples may also be obtained by means of 100mm diameter sampling tubes with a cutting edge. The sampler shall be slightly oiled or greased inside and outside to reduce friction. The sampler shall be pushed into the soil and while doing so soil around the tube shall be carefully removed. In case it is not possible to push the sampler it may be driven by light blows from a "monkey".

6.6.4 In case it is not possible to collect undisturbed samples in the pit, in-situ density of soil shall be determined by sand replacement method. The specification, equipments, accessories etc required for the test and the procedure of testing shall be in accordance with IS: 2720, Part-XXVIII. No separate payment shall be made for this test.

6.6.5 After the completion of the test, sampling and visual examination, the pit shall be suitably backfilled as directed by the engineer-in-charge. Unless otherwise specified excavated soil shall be used for this purpose.

### 6.7 Vane Shear Test

Field vane shear test shall be performed inside the borehole to determine the shear strength of cohesive soils, especially of soft and sensitive clays which are highly susceptible to sampling disturbance. This test shall be conducted by advancing a four winged vane of suitable size (75mm or 100mm diameter as per the soil condition) into the soil upto desired depth and measuring the torque required to rotate the vane. The specification for equipments & accessories required, the test procedure and field observations etc shall be as per IS: 4434. This test may also be conducted by direct penetration from



STANDARD SPECIFICATION  
FOR  
GEOTECHNICAL INVESTIGATION

SPEC. NO. PE-TS 999-603-002

VOLUME II

SECTION D

REV. NO. 0 DATE 11.06.2009

SHEET 23 OF 50

the ground surface. If the cuttings at the test depth in the bore hole show any presence of gravel, sand, shells, decomposed wood etc which are likely to influence the test results substantially, the test at that particular depth may be omitted with the permission of the engineer-in-charge. However the test shall be conducted at a depth where these obstructions cease to occur. On completion of the test the results shall be reported in an approved proforma as specified in IS: 4434, Appendix-A.

### 6.8 Static Cone Penetration Test

Static cone penetration test shall be conducted to know the soil stratification and to estimate the various physical and engineering properties of soil. The cone penetrometer shall be advanced by pushing and the static force required for unit penetration shall be determined. The test shall be conducted using a 200kN capacity mechanically operated equipment upto the specified depth or refusal whichever is earlier. For this test, 'refusal' means meeting a very hard strata which cannot be penetrated at the rate of at least 0.3cm/sec even when the equipment is loaded to its full capacity. The specification for the equipment and accessories required for performing the test, test procedure, field observation and reporting of results shall conform to IS : 4968, Part-III. At the ground level, preboring upto 0.5m depth shall be permitted if the overlying strata is very hard. No extra payment shall be made on account of this preboring. Continuous record of the penetration resistance shall be maintained.

### 6.9 Dynamic Cone Penetration Test

Dynamic cone penetration test shall be conducted using bentonite slurry by driving a standard size cone attached to the bottom of a string of drill rods. The test shall be conducted upto the specified depth or refusal whichever is earlier. Refusal shall be considered when the blow count exceeds 150 for 300mm penetration. The specification for the equipment and accessories required for performing the test, test procedure, field observations and reporting of results shall conform to IS:4968, Part-II. The driving system shall comprise of a 65 kg weight having a free fall of 0.75m. The cone



STANDARD SPECIFICATION  
FOR  
GEOTECHNICAL INVESTIGATION

SPEC. NO. PE-TS 999-603-002

VOLUME II

SECTION D

REV. NO. 0 DATE 11.06.2009

SHEET 24 OF 50

shall be of 65mm diameter provided with vents for continuous flow of bentonite slurry through the cone and rods in order to avoid friction between the rods and soil. On completion of the test, the results shall be presented as a continuous record of number of blows required for every 300mm penetration of the cone into the soil in a suitable chart supplemented by a graphical plot.

## 6.10 Plate Load Test

- 6.10.1 Plate load test shall be conducted to determine the bearing capacity and load/settlement characteristics of soil at shallow depth by loading a plane and levelled steel plate kept at the desired depth and measuring the settlement under different loads until a desired settlement takes place or failure occurs. The specification for equipment and accessories required for conducting the test, the test procedure, field observations and reporting of results etc shall conform to IS: 1888. The location and depth of the test shall be as given in the drawing or as indicated by the engineer-in-charge. Undisturbed tube samples as specified in clause 6.6.3 (b) shall be collected at 1m and 2.5m depths from the ground level for carrying out laboratory tests.
- 6.10.2 The size of pit shall not be less than five times the plate size and the depth shall be as specified. All provisions regarding excavation and visual examination of pit under clause 6.6.1 and 6.6.2 shall apply here also.
- 6.10.3 If the ground water table is at a depth higher than the specified test depth, the ground water table shall be lowered and maintained at the test depth for the entire duration of the test. Dewatering shall be at the cost of the contractor.
- 6.10.4 Unless otherwise specified the reaction method of loading shall be adopted. Settlement shall be recorded from dial gauges placed at four diametrically opposite ends of the test plate. The test plate shall be of 600mm x 600mm size and atleast 25mm thick. The bottom of the pit shall be levelled before placing the plate in position for conducting the test.



STANDARD SPECIFICATION  
FOR  
GEOTECHNICAL INVESTIGATION

SPEC. NO. PE-TS 999-603-002

VOLUME II

SECTION D

REV. NO. 0 DATE 11.06.2009

SHEET 25 OF 50

- 6.10.5 A seating load of 7kN/sqm shall be applied and after the dial gauge readings are stabilized, the load shall be released and the initial readings of the dial gauges be recorded after they indicate constant reading. The load shall be increased in stages. These stages shall be 20, 40, 70, 100, 150, 200, 250, 300, 400, 500, 600 and 800kN per sqm or as directed by the engineer-in-charge. Under each loading stage, record of 'time vs settlement' shall be kept as specified in IS:1888.
- 6.10.6 In case of cohesive soils, each load increment shall be maintained until the settlement is less than 0.02mm/minute or 6 hours whichever is later. Dial gauge readings for settlement shall generally be taken at 1, 2.25, 4, 6.25, 9, 16, 25, 60, 90 and 120 minutes from the start of each stage of loading. Thereafter the readings shall be taken at hourly interval upto a further 4 hours and at two hours interval thereafter for another 6 hours.
- 6.10.7 Other than cohesive soils ( for all other type of soils), each stage loading shall be maintained for a minimum duration of one hour or till the settlement rate reduces to 0.02mm/minute whichever is later. No extrapolation of settlement rate from periods less than one hour shall be permitted. The final loading shall be maintained for 24 hours. During unloading, reading of dial gauge shall be recorded for each stage of unloading.
- 6.10.8 Loading shall be carried out in stages as specified above till one of the following conditions occur.
- Failure of soil under the plate i.e. the settlement of the plate at constant load becomes progressive and reaches a value of 40 mm or more.
  - Load intensity of 800 kN/sqm is reached without failure of the soil.
- 6.10.9 Backfilling of the pit shall be carried out as per the directions of the engineer-in-charge. Unless otherwise specified the excavated soil shall be used for this purpose.



STANDARD SPECIFICATION  
FOR  
GEOTECHNICAL INVESTIGATION

SPEC. NO. PE-TS 999-603-002

VOLUME II

SECTION D

REV. NO. 0 DATE 11.06.2009

SHEET 26 OF 50

### 6.11 Cyclic Plate Load Test

This test shall be carried out to determine the dynamic soil properties required for the analysis of foundation subjected to dynamic loads. This test shall be conducted on similar lines as the ordinary plate load test with an addition that unloading shall also be done before each stage of loading. Test set up, load increment and maximum load intensity etc shall be as per Clause- 6.10.

- 6.11.1 After each stage of loading, the load shall be removed in a minimum of two stages and as directed by the engineer-in-charge. After each stage of reduction of load, dial gauge readings and settlements shall be taken for atleast one hour until the readings stabilize. Thereafter the next loading stage shall commence. Recording and analysis of test data shall be as per IS: 5249.

### 6.12 Field California Bearing Ratio Test

This test shall be carried out to obtain the properties of soil required for the design of roads. The equipments and accessories required for carrying out the test, test procedure, recording of observations and presentation of results shall conform to IS: 2720 part XXXI. The test locations and depth shall be as specified in the drawings or as directed by the engineer-in-charge.

### 6.13 Electrical Resistivity Test

This test shall be conducted to determine the electrical resistivity of soil required for designing safety grounding system for the entire power plant area. The specification for the equipments and other accessories required for performing the test, test procedure and reporting of field observations shall conform to IS:3043. The test shall be conducted using Wenner's four electrode method as specified in IS:1892, Appendix-B2. Unless otherwise specified, at each test location the test shall be conducted along two perpendicular lines parallel to the co-ordinate axes. On each line, the spacing of electrodes shall be kept at 1m, 2m, 5m and 10m. Testing shall be done during the driest season prevalent in the area to the extent possible. In no circumstances shall the testing be done during or



STANDARD SPECIFICATION  
FOR  
GEOTECHNICAL INVESTIGATION

SPEC. NO. PE-TS 999-603-002

VOLUME II

SECTION D

REV. NO. 0 DATE 11.06.2009

SHEET 27 OF 50

immediately after the rainy season or persistent rains or in the vicinity of any existing water body such as ponds, streams etc.

#### 6.14 Seismic Refraction Test

6.14.1 This test shall be carried out to establish the rock and soil profiles of varying density. The dynamic shear modulus of the soil shall also be obtained from the results of this test. The specification for the equipments and other accessories, procedure for carrying out the test, recording and analysis of results and their presentation shall conform to IS: 1892.

6.14.2 This test shall be carried out by inducing shock waves into the soil by striking a plate placed on the ground surface with a hammer. The shock waves shall be picked up through geophones placed on the ground surface at regular intervals in line with the plate along a straight line. The time elapsed before the waves reach the geophones shall be recorded to an accuracy of one millisecond or better.

6.14.3 The distance between the shock point and the geophones shall be increased to cover a wider area. Alternatively, multiple geophones shall be used simultaneously using multiple channel seismograph to record the arrival time and intensity of waves reaching the geophones. The spacing of geophones shall be 5m. As the distance between geophones and the shock producing point are increased, the time lapse for the waves passing through different underlying strata and reaching the geophone shall be recorded. The wave forms shall be recorded for each test using multiple channel seismograph.

6.14.4 The test shall be conducted along traverses in two orthogonal directions as specified in the drawing or as directed by the engineer-in-charge. During testing, proper care shall be taken to avoid disturbance caused due to the movement of vehicles or other working operations around the test location. The type of wave (compression or shear) shall be analysed properly using the data recorded during the test.



STANDARD SPECIFICATION  
FOR  
GEOTECHNICAL INVESTIGATION

SPEC. NO. PE-TS 999-603-002

VOLUME II

SECTION D

REV. NO. 0 DATE 11.06.2009

SHEET 28 OF 50

### 6.15 Cross Hole Shear Test

This test shall be generally carried out in accordance with IS: 13372 to establish the dynamic elastic properties of soil and rock. In this test, the seismic waves are to be picked up in two adjacent receiver boreholes. The spacing of boreholes shall be determined so as to obtain good results. The boreholes shall be uncased in the portion carrying the geophones. However it should be kept filled with water or drilling mud in order to ensure perfect contact between the borehole wall and the geophone. In case of cased hole preferably a low velocity material such as a high impact PVC should be used for casing and it is essential that it should be well grouted behind in order to make an intimate contact with the soil. The charge shall be installed within the depth as specified and the waves shall be picked up from the geophones installed at required depths in receiver boreholes. Knowing the travel time from shot hole to receiver hole and corresponding distance, the velocity of the waves is determined which enables to estimate dynamic elastic modulus, shear modulus and Poisson's ratio. In each receiver borehole multiple geophones shall be provided at 2m interval (with starting depth as 3m below ground level) to cover the depth and various strata as specified. Intensity of the waves shall be recorded by multiple channel seismograph.

### 6.16 Pressuremeter Test

6.16.1 This test shall be conducted in bore holes at desired depth to obtain the in-situ stress-strain characteristics and strength parameters of soil/rock layer by measuring the deformation of the probe at different pressures of the volumemeter. The location and depth of the test shall be as given in the drawing or as per the directions of the engineer-in-charge.

6.16.2 All precautions shall be taken to ensure a smooth bore hole of required diameter with minimum disturbance to the surrounding soil. In soft, loose and sensitive soils, the bore hole shall be predrilled deeper than the testing depth for enough so that the cuttings settling at the bottom of the bore hole shall not interfere with the test.



STANDARD SPECIFICATION  
FOR  
GEOTECHNICAL INVESTIGATION

SPEC. NO. PE-TS 999-603-002

VOLUME II

SECTION D

REV. NO. 0 DATE 11.06.2009

SHEET 29 OF 50

6.16.3 The equipment shall be calibrated for pressure losses (membrane correction/air calibration) and volume or radius changes (line calibration/thick wall rigid steel cylinder test) before starting of test and at regular intervals as per the manufacturer's specification.

6.16.4 Maximum value of pressure correction shall not be more than 50% of limit pressure. The total volume losses in the system shall not exceed 0.5% of the static probe volume per 100kPa. Volume correction may be neglected in soil if it is less than 0.1% of probe volume per 100 kPa.

6.16.5 The test shall be performed by expanding a cylindrical probe to obtain a pressure vs volume or pressure vs radius curve as specified in IS:1892. The probe may be of Ax, Bx or Nx size. However the size of the borehole shall be compatible to the size of pressuremeter probe. Hose pipe connecting the probe with the surface unit shall be of flexible tubing of single or coaxial type. The equipment should be able to reach a maximum pressure of 5000kPa for testing in soil and 8000kPa for testing in rock. The accuracy of measuring device shall be such that a change of 0.2% of static probe volume or 0.1% of probe radius is measurable as specified in IS:1892.

6.16.6 The probe shall be lowered down to the required depth as soon as the boring is completed so as to limit the expansion of soil due to release of stresses. The probe shall be held by a clamping device ensuring that it is not located at the interface of two different soil/rock layers.

6.16.7 The pressure shall be increased in at least 20 equal stages as directed by the engineer-in-charge. At each stage the pressure shall be maintained for a period of at least 60 seconds and volume reading shall be taken for 7 to 14 minutes. The volume of water sent into the probe during this period shall be measured upto an accuracy of 0.01cum. In case the water level in the volumemeter drops rapidly, it is necessary to close the volumemeter valve quickly so that the reservoir does not empty and allow air or gas into the tubing.

6.16.8 The test shall be carried out in stages till one of the following conditions occur.



STANDARD SPECIFICATION  
FOR  
GEOTECHNICAL INVESTIGATION

SPEC. NO. PE-TS 999-603-002

VOLUME II

SECTION D

REV. NO. 0 DATE 11.06.2009

SHEET 30 OF 50

- a) The volume of the probe is doubled
- b) Ultimate failure of soil/rock occurs
- c) Load intensity of 5000kPa for soil and 8000kPa for rock is reached without failure.

6.16.9 If the shape of uncorrected pressure vs volume curve drastically varies from the ideal test curve, the test shall be repeated at no extra cost to the owner/BHEL at a different depth as decided by the engineer-in-charge.

6.16.9 On completion of the test, all results mentioned in Clause- 9.2 shall be reported.

## 7.0 FIELD INVESTIGATION - ROCK

### 7.1 Rock Drilling

Drilling in rock shall be done at specified locations or as per the directions of the engineer-in-charge. Before commencing drilling, it shall be proved that characteristics of rock has been met with as mentioned in clause 6.1.1(b). The starting depth of drilling in rock as mentioned in clause 6.1.1(b) shall be certified by the engineer-in-charge. The portion drilled in rock shall be backfilled with 1part of cement : 3 part of sand (1:3) grout unless otherwise specified and as directed by the engineer-in-charge.

#### 7.1.1 Equipment

a) Core drilling shall be done by rotary motion using diamond bit. The feed or thrust to the drilling bit shall be actuated by hydraulic system. The rotary core drilling equipment and procedure for drilling shall conform to IS: 6926. The equipment shall be provided with necessary facilities to regulate the spindle speed, bit pressure and water pressure during core drilling to get a good core recovery.

b) Drilling shall be carried out with Nx size diamond tipped drill bits or impregnated diamond bits depending on the type of rock encountered. Double tube swivel core barrel of Type B conforming to IS: 6926 shall be used to ensure a good core recovery and to pick



STANDARD SPECIFICATION  
FOR  
GEOTECHNICAL INVESTIGATION

SPEC. NO. PE-TS 999-603-002

VOLUME II

SECTION D

REV. NO. 0 DATE 11.06.2009

SHEET 31 OF 50

up cores from all layers of rock. Suitable core catchers shall be used to ensure continuous and good core recovery.

### 7.1.2 Procedure

a) The drilling fluid shall be clean water. Circulation of drilling fluid shall be started before the core barrel reaches the bottom of the hole to prevent cuttings or sludge from entering the core barrel at the start of coring. Drilling fluid shall be circulated continuously down the hollow rods and the sludge conveying the rock cuttings to the surface shall be collected.

b) When drilling through soft/weathered/fractured rock, water circulation must be reduced so as to avoid shattering/breaking of core.

c) The rotational speed of the bit (spindle speed), the amount of downward pressure applied on the bit (bit pressure) and water pressure shall be suitably adjusted and properly monitored so that the core is collected with least disturbance and to avoid shearing of the core from its base. Bit speed, bit pressure, water pressure for the type of bit for various rock types shall be as per Appendix A of IS:6926.

d) No drill run shall exceed 0.75m in length. This can be increased to 1.5m provided the core recovery observed is more than 80% in two successive 0.75m drill runs and on approval from the engineer-in-charge. If the core recovery is less than 20% then SPT shall be performed before commencing the next drill run as explained in Clause- 6.2.

e) If at any time blocking of the bit or grinding of the core is observed, the core barrel shall be immediately withdrawn from the borehole regardless of the length of drill run completed.

### 7.1.3 Observations

a) The colour of return water at regular intervals, the depth at which any change of colour of return water is observed, the depth of



STANDARD SPECIFICATION  
FOR  
GEOTECHNICAL INVESTIGATION

SPEC. NO. PE-TS 999-603-002

VOLUME II

SECTION D

REV. NO. 0 DATE 11.06.2009

SHEET 32 OF 50

occurrence and amount of flow of hot water if encountered shall be recorded.

b) The depths through which a uniform rate of penetration was maintained, the depth at which a marked change in rate of penetration or sudden fall of drill rod occurs, the depth at which any blockage of drill bit causing core loss if any etc shall be recorded.

c) Any heavy vibration or torque noticed during drilling should be recorded together with the depth of occurrence.

d) Special conditions like the depth at which grouting was done during drilling, presence of artesian conditions, loss of drilling fluid, observation of gas discharge with return water etc shall also be observed and recorded.

e) During drilling operation, observation on return water, rate of penetration etc shall be recorded in a proforma as given in IS: 5313, Appendix-A.

#### 7.1.4 Core Samples

a) Core samples shall be extracted by the application of a continuous pressure at one end of the core with the barrel held horizontally without vibration. Friable cores shall be extracted from the barrel directly into a suitable sized half round plastic channel section. Care shall be taken to maintain the direction of extrusion of sample same as that while coring to avoid stress reversal.

b) Immediately after withdrawal from the core barrel, the cores shall be placed in a tray and transferred into boxes specially prepared for the purpose. The boxes shall be made from seasoned timber or any other durable material and shall be indexed on top of the lid as per IS:4078. The cores shall be numbered serially and arranged in the boxes in a sequential order. The description of the core samples shall be recorded as per IS: 4464. Where no core is recovered, it shall be recorded as specified in the continuous record of core recovery and RQD in the corelog as per IS:11315, Part-II.



STANDARD SPECIFICATION  
FOR  
GEOTECHNICAL INVESTIGATION

SPEC. NO. PE-TS 999-603-002

VOLUME II

SECTION D

REV. NO. 0 DATE 11.06.2009

SHEET 33 OF 50

c) The basic information for the description of rocks shall cover  
i) degree of weathering ii) discontinuity spacing iii) strength iv)  
colour v) grain size vi) structural condition, the mineralogy of the  
grains and cementing material vii) rock name, special features like  
major joint planes, features/laminations, faults etc.

## 7.2 Standard Penetration Test

The relevant hardness of rocks shall be tested in boreholes after every drill run of 0.75m in rock if core recovery observed is less than 20% or as directed by the engineer-in-charge. The testing equipment and arrangement shall be conforming to IS: 2131. The number of blows for each 75mm penetration to a total penetration of 450mm shall be recorded. Penetration for every 50 blows shall be recorded and the test shall be stopped at a total of 100 blows.

## 7.3 Plate Load Test

The test shall be conducted as described under Clause- 6.10 for soil subject to the following changes.

The test plate shall be of size 45cm x 45cm and at least 25mm thick. The maximum load shall be 1500 kN/sqm to be applied in stages of 25, 50, 100,150,200, 300, 400, 600, 800, 1000, 1200, 1400 and 1500 kN per sqm. Under each load the time Vs settlement shall be recorded and plotted.

## 7.4 Pressuremeter Test

This test shall be conducted as described under Clause- 6.16 for soil subject to the following changes. The test shall be carried out till one of the following condition occurs.

- a) The volume of the probe is doubled
- b) Ultimate failure of rock
- c) Load intensity of 8000 kN/sqm is reached without failure.

## 7.5 Cross Hole Shear Test

This test shall be conducted as described under Clause- 6.15 for soil.



STANDARD SPECIFICATION  
FOR  
GEOTECHNICAL INVESTIGATION

SPEC. NO. PE-TS 999-603-002

VOLUME II

SECTION D

REV. NO. 0 DATE 11.06.2009

SHEET 34 OF 50

## 7.6 Permeability Test

Permeability test shall be conducted in bed rock inside the bore hole by pumping in water under pressure to determine the percolation capacity of the rock strata. This test shall be conducted in uncased and ungrouted sections of the drill hole. Clear and clean water shall be used for the purpose of both drilling and testing. The specification for the equipments and other accessories, test procedure etc shall conform to IS: 5529, Part-II. The length of the test section shall be either 1.5m or 3m as per field conditions and as per the directions of the engineer-in-charge. The level of water table (if any) in the bore hole shall be recorded and the drill hole shall be cleaned before the start of the test. Depending upon the depth of the test section, single or double packer method shall be adopted. Care shall be taken to maintain water tightness of all the joints and connections during testing.

### a) Single Packer method

This method shall be adopted when the bottom elevation of the test section is the same as the bottom of the drill hole. The packer shall be fixed at the top level of test section such that only the test section lies below the packer. Water shall then be pumped through a pipe into the test section under a required pressure and maintaining it till a constant quantity of water intake is observed. The amount of water percolating through the hole shall be recorded at every 5 minute interval. The test shall be repeated by increasing the pressure at regular intervals upto a pressure limit as specified in IS: 5529, Part-II. The details and observations shall be recorded in a proforma as recommended in IS: 5529, Part-II, Appendix-B.

### b) Double Packer method

This method shall be adopted when the permeability of an isolated section inside a drill hole is to be determined. Packers shall be fixed both at the top and bottom of the test section such that their spacing is exactly equal to the length of the test section. The test shall then be conducted as specified in Clause- 7.6(a).



STANDARD SPECIFICATION  
FOR  
GEOTECHNICAL INVESTIGATION

SPEC. NO. PE-TS 999-603-002

VOLUME II

SECTION D

REV. NO. 0 DATE 11.06.2009

SHEET 35 OF 50

## 8.0 LABORATORY INVESTIGATION

### 8.1 Essential Requirements

a) All laboratory tests shall be conducted in an approved laboratory using approved apparatus complying with the requirements and specifications of Indian standards or other approved standards for this class of work. It shall be checked that the apparatus are in good working condition before starting the laboratory tests. Calibration of all the instruments and their accessories shall be done carefully and precisely.

b) Depending on the type of sub strata encountered, appropriate laboratory tests shall be conducted on soil and rock samples collected in the field. Laboratory tests shall be scheduled and performed by a qualified and experienced personnel who are thoroughly conversant with the work. Tests indicated in the schedule of items shall be performed on soil, rock and water samples as per relevant IS codes. One copy of all the laboratory test data records shall be submitted to the owner progressively every week. Laboratory tests shall be carried out concurrently with field investigation since initial laboratory test results could be useful in planning the later part of field work. **A schedule of laboratory tests shall be established by the contractor and the same shall be submitted and got approved by the engineer-in-charge before starting of laboratory tests.**

c) All samples whether undisturbed or disturbed shall be extracted, prepared and examined by a competent personnel properly trained and experienced in soil sampling, examination, testing and in using the apparatus as per the specified standards.

d) Undisturbed soil samples retained in liners or seamless tube samplers shall be taken out without causing any disturbance to the samples using suitably designed extruder just prior to actual testing. If the extruder is horizontal, proper support shall be provided to prevent the sample from breaking. For screw type extruders the pushing head shall be free from the screw shaft so that no torque is applied to the soil sample in contact with the pushing head. For soft clay samples, the sample tube shall be cut by means of a high speed



STANDARD SPECIFICATION  
FOR  
GEOTECHNICAL INVESTIGATION

SPEC. NO. PE-TS 999-603-002

VOLUME II

SECTION D

REV. NO. 0 DATE 11.06.2009

SHEET 36 OF 50

hacksaw to specified test length and placed over the mould before pushing the sample into it with a suitable piston.

e) While extracting a sample from a liner or tube care shall be taken to see that its direction of movement is the same as that during sampling to avoid stress reversal.

f) On all undisturbed soil samples tested for bulk density, water content, grain size distribution, liquid limit and plastic limit tests shall also be performed.

g) On all rock samples tested for unconfined compression test, bulk density and water content tests shall also be performed.

h) After completion of all tests, a summary of test results for each soil and rock sample shall be presented in a proforma as enclosed in **Annexure-A & B** respectively. Chemical test results on soil and water samples shall be furnished in a tabular form separately.

## 8.2 Tests

Tests as indicated in this specification and as called for by the engineer-in-charge shall be conducted. The tests shall include the following.

### a) Tests on Undisturbed and Disturbed Soil Samples

- Visual and engineering classification
- Sieve analysis and hydrometer analysis
- Liquid, plastic and shrinkage limits
- Specific gravity
- Chemical analysis
- Swell pressure and free swell index determination
- Proctor compaction
- California bearing ratio



STANDARD SPECIFICATION  
FOR  
GEOTECHNICAL INVESTIGATION

SPEC. NO. PE-TS 999-603-002

VOLUME II

SECTION D

REV. NO. 0 DATE 11.06.2009

SHEET 37 OF 50

**b) Test on Undisturbed Soil Samples**

- Bulk density and moisture content
- Relative density (for sand)
- Unconfined compression test
- Box shear test
- Triaxial shear tests (depending on the type of soil and field conditions on undisturbed or remoulded samples)
  - i) Unconsolidated undrained
  - ii) Consolidated undrained test with the measurement of pore water pressure
  - iii) Consolidated drained
    - One dimensional consolidation test

**c) Test on Rock Samples**

- Visual classification
- Water absorption, porosity and density
- Specific gravity
- Hardness
- Slake durability
- Unconfined compression test (both at saturated and at in-situ water content)
- Point load strength index
- Deformability test (both on saturated and dry samples)



STANDARD SPECIFICATION  
FOR  
GEOTECHNICAL INVESTIGATION

SPEC. NO. PE-TS 999-603-002

VOLUME II

SECTION D

REV. NO. 0 DATE 11.06.2009

SHEET 38 OF 50

### c) Chemical Analysis of Sub-soil and Ground Water

#### 8.3 Salient Test Requirements

a) Remoulded soil specimen whenever desired shall be fully reworked at field density and natural moisture content. For conducting CBR test and triaxial test for dyke/road material the sample shall be remoulded to 95% of standard proctor density.

b) Triaxial shear test shall be conducted on undisturbed soil samples saturated by the application of backpressure. Only if the water table is at sufficient depth such that chances of its rising to the base of the footing are meagre or nil, the triaxial tests shall be performed on the specimens at natural moisture content. Each test shall be carried out on a set of three test specimens from one sample at cell pressures equal to 100, 200 and 300kN/sqm or as required depending on the soil conditions.

c) Effective stress triaxial shear test shall be consolidated undrained with pore water pressure measurement. The test shall be conducted at cell pressures of 100, 200 and 300kN/sqm ensuring complete consolidation at each stage.

d) Direct shear test shall be conducted on undisturbed soil samples. The three normal vertical stresses for each test shall be 100, 200 and 300 kN/sqm or as required depending on the soil conditions.

e) Consolidation test shall have loading stages of 10, 25, 50, 75, 100, 200, 400 and 800 kN/sqm. Rebound curve shall be recorded for all the samples by unloading the specimen at the in-situ stress of the specimen. Additional rebound curves shall also be recorded whenever desired by the engineer-in-charge.

f) Chemical analysis of sub-soil shall include determination of pH value, carbonate, sulphate (both  $SO_3$  and  $SO_4$ ), chloride and nitrate contents, organic matter, salinity and any other chemicals harmful to the foundation material. The contents in soil shall be indicated as percentage.



STANDARD SPECIFICATION  
FOR  
GEOTECHNICAL INVESTIGATION

SPEC. NO. PE-TS 999-603-002

VOLUME II

SECTION D

REV. NO. 0 DATE 11.06.2009

SHEET 39 OF 50

g) Chemical analysis of sub-soil water sample shall include the determination of the properties such as colour, odour, turbidity, pH value and chemical contents such as carbonate, sulphate (both SO<sub>3</sub> and SO<sub>4</sub>), chloride, nitrate, organic matter and any other chemicals harmful to the foundation material. The contents such as sulphate etc shall be indicated as ppm by weight.

h) The laboratory CBR test shall be performed on undisturbed or on remoulded sample as per the drawing or as directed by the engineer-in-charge in soaked and unsoaked conditions.

## 9.0 REPORT

### 9.1 General

a) On completion of all the field and laboratory works, the contractor shall submit a draft report containing geological information of the region, procedure adopted for investigation, field observations, summarised test data, conclusion and recommendations. The report shall include detailed borelogs, sub-soil sections, field test results, laboratory observations and test results in both tabular as well as graphical forms, practical and theoretical considerations for the interpretation of test results, the supporting calculations for the conclusions drawn etc. Initially, the contractor shall submit three copies of the report in draft form for the owner/BHEL's review.

b) After review of the draft report, the employer's comments will be intimated to the contractor. The contractor shall incorporate the comments and after getting the amended draft report approved, five copies of the detailed final report shall be submitted alongwith one set of reproducible of the graphs, tables etc. Any expenditure on account of redrafting, finalising the report etc shall be deemed to have been included in the quoted rates.

c) The detailed final report based on field observations, in-situ and laboratory tests shall encompass theoretical as well as practical considerations for foundation of different type of structures envisaged in the area under investigation. The contractor shall acquaint himself about the type of structures, foundation loads and other information required from the engineer-in-charge.



STANDARD SPECIFICATION  
FOR  
GEOTECHNICAL INVESTIGATION

SPEC. NO. PE-TS 999-603-002

VOLUME II

SECTION D

REV. NO. 0 DATE 11.06.2009

SHEET 40 OF 50

## 9.2 Data to be Furnished

The report shall also include but not be limited to the following.

- a) A Plot Plan/Geotechnical Investigation Layout showing the location and reduced levels of all field tests e.g. bore holes, trial pits, plate load tests etc properly drawn to scale and dimensioned with reference to the established grid lines.
- b) Geological information of the area such as geomorphology, geological structure, lithology, stratigraphy and tectonic faults, seismicity of the region and site, core recovery and rock quality designation etc.
- c) Past observations and historical data if available for the area or for other areas with similar soil profile for similar structures in the surrounding areas.
- d) A true cross section of all individual boreholes and trial pits with reduced levels and co-ordinates showing the classification and thickness of individual stratum, position of ground water table, various in-situ tests conducted and samples collected at different depths and the rock stratum if met with.
- e) A set of longitudinal and transverse soil/rock profiles connecting various bore holes in order to give a clear picture of the variation of the subsoil strata as per IS: 6065.
- f) Water level contours and rock level contours
- g) Plot of standard penetration test 'N' values (both uncorrected and corrected) with depth for identified areas.
- h) Results of all field tests in tabular as well as in graphical forms.
- i) Results of all laboratory tests summarised (i) for each sample as well as (ii) a consolidated table giving the layer-wise soil and rock properties . All the relevant charts, tables, graphs, figures, supporting



STANDARD SPECIFICATION  
FOR  
GEOTECHNICAL INVESTIGATION

SPEC. NO. PE-TS 999-603-002

VOLUME II

SECTION D

REV. NO. 0 DATE 11.06.2009

SHEET 41 OF 50

calculations, conclusions and photographs of representative rock cores and trial pits shall be furnished.

j) For all triaxial shear tests, stress vs strain diagrams as well as Mohr's circle envelopes shall be furnished. If back pressure is applied for saturation, the magnitude of the same shall be indicated. The value of modulus of elasticity 'E' shall be furnished for all tests along with relevant calculations.

k) For all consolidation tests the following curves shall be furnished.

e vs log P

e vs P and

Compression vs log t or square root of t (depending upon shape of the plot for proper determination of coefficient of consolidation)

The point showing initial condition ( $e_0$ ,  $P_0$ ) of the soil shall be marked on the curves.

l) Values of compression index, coefficient of volume compressibility etc shall be furnished. The procedure adopted for calculating the compression index from the field curve and settlement of soil strata shall be clearly specified. The time required for 50% and 90% primary consolidation along with secondary settlement if significant shall also be calculated.

m) For pressuremeter tests, the following shall be furnished.

Calibration record including description of membrane and sheath on probes, dimensions of thick walled cylinder, length of flexible tubing, calibration curves and temperature etc.

Drilling record including borehole number, method of making borehole, log with soil type and condition, depth of water table in the borehole, weather and temperature etc.

Test record including type of test, date and time, depth of centre point of probe, volume readings at 30 and 60 second elapsed time and corresponding pressure readings and notes on any deviation from standard test procedure etc.



STANDARD SPECIFICATION  
FOR  
GEOTECHNICAL INVESTIGATION

SPEC. NO. PE-TS 999-603-002

VOLUME II

SECTION D

REV. NO. 0 DATE 11.06.2009

SHEET 42 OF 50

Field pressuremeter, creep and air calibration curves indicating  $P_o$ ,  $P_f$  and  $P_l$ . Corrected pressuremeter and creep curves indicating  $P_o$ ,  $P_f$ ,  $P_l$  along with calculation for the corrections.

n) Values of cohesion, angle of internal friction, pressuremeter modulus, shear modulus and co-efficient of sub-grade reaction along with sample calculations. Calculation for allowable bearing pressures and corresponding total settlements for shallow foundations and load carrying capacity calculation of piles in various modes etc.

o) Analysis and discussion of test results.

### 9.3 Recommendations

Recommendations shall be given areawise duly considering the type of soil/rock, structure, foundation type and ground water table etc in the area. The recommendations shall include but not be limited to the following.

a) Type of foundation to be adopted for various structures duly considering the sub strata characteristics, water table, total settlement permissible for the structures and equipments, minimum depth and width of foundation etc.

b) For shallow foundations the following shall be furnished with comprehensive supporting calculations.

i) Net safe bearing pressure for isolated square/rectangular footings and continuous strip footings of sizes 1, 2, 3, 4 & 5m at different founding depths of 1, 2, 3, 4 & 5m below ground level considering both shear failure and settlement criteria giving reasons for the type of shear failure adopted in the calculation.

ii) Net safe bearing pressure for raft foundation of widths greater than 6m at 2, 3, 4 & 5m below ground level considering both shear failure and settlement criteria.



STANDARD SPECIFICATION  
FOR  
GEOTECHNICAL INVESTIGATION

SPEC. NO. PE-TS 999-603-002

VOLUME II

SECTION D

REV. NO. 0 DATE 11.06.2009

SHEET 43 OF 50

iii) Modulus of sub-grade reaction and modulus of elasticity from plate load test results along with time-settlement curves and load-settlement curves in both natural and log-log graph.

c) If piling is envisaged the following shall be furnished with comprehensive supporting calculations.

i) Type of pile and reasons for recommending the same duly considering the sub strata characteristics.

ii) Suitable founding strata for the pile.

iii) Estimated length of pile for 800kN (450mm dia.), 1050kN (500mm dia.), 1500kN (600mm dia.) and 4500kN (1070mm dia.) capacities. End bearing and frictional resistance shall be indicated separately. Safe lateral and tensile load carrying capacities of pile with supporting calculations.

iv) Magnitude of negative skin friction if any.

d) Coefficient of permeability of various sub-soil and rock strata based on in-situ permeability tests.

e) Cone resistance, frictional resistance, total resistance and settlement analysis for different size of foundations.

f) Electrical resistivity of sub-soil based on electrical resistivity tests including electrode spacing vs cumulative resistivity curves.

g) Dynamic soil properties such as dynamic shear modulus and Poisson's ratio etc from cross-hole shear and seismic refraction tests and coefficient of elastic uniform compression from cyclic plate load tests.

h) Suitability of the soil for construction of roads and embankments, their stable slopes for shallow and deep excavations, active and passive earth pressures, earth pressure at rest and modulus of elasticity as a function of depths for the design of underground structures etc.



STANDARD SPECIFICATION  
FOR  
GEOTECHNICAL INVESTIGATION

SPEC. NO. PE-TS 999-603-002

VOLUME II

SECTION D

REV. NO. 0 DATE 11.06.2009

SHEET 44 OF 50

- i) Suitability of locally available soils at site for filling and back filling purposes.
- j) If expansive soil is met with, then recommendation on removal or retainment of the same under the structures/roads etc shall be given. In the latter case, detailed specifications of any special treatment required including specification for materials to be used, construction method, equipments to be deployed etc shall be furnished.
- k) Protective measures based on chemical nature of soil and ground water with due regard to the potential deleterious effects on concrete, steel and other building materials etc. Remedial measures for sulphate attack and acidity shall be dealt in detail.
- l) Susceptibility of sub soil strata to liquefaction in the event of earthquake. If so, recommendation for remedial measures.
- m) Identification of any other potential geotechnical problems and their remedial measures.
- n) Description of measures required for erosion control.
- o) Identification of corrective measures required for the improvement of sub surface conditions such as removal of poor sub soil/material and in-situ densification etc. If ground improvement is recommended then its detailed specification, specification for the materials to be used, construction method, equipments to be deployed etc shall be furnished.

## **10.0 RATES & MEASUREMENTS**

### **10.1 RATES**

- a) The item of work in the schedule of quantities describes the work very briefly. The various items of the schedule of quantities shall be read in conjunction with the corresponding sections in the technical specification including amendments and additions if any. For each item in the schedule of quantities, the bidder's rates shall include all the activities covered in the description of the items as well as for



STANDARD SPECIFICATION  
FOR  
GEOTECHNICAL INVESTIGATION

SPEC. NO. PE-TS 999-603-002

VOLUME II

SECTION D

REV. NO. 0 DATE 11.06.2009

SHEET 45 OF 50

all necessary operations in details described in the technical specification.

b) No claims shall be entertained if the details shown on the released for construction drawings differ in any way (e.g. location and depth of tests, number of tests etc) from those shown on the tender drawings.

c) The unit rates quoted shall include minor details which are obviously and fairly intended and which may not have been included in these documents but are essential for the satisfactory completion of the work.

d) The bidders quoted rates shall be inclusive of providing all equipments, men, materials, skilled and unskilled labours, making observations, establishing the ground level and coordinates at location of each bore hole, test pit etc by carrying levels from one established bench mark and distances from one set of grid lines furnished by the engineer-in-charge. Also no extra payments shall be made for conducting the standard penetration tests, collection, packing and transportation of all the samples and cores, recording of all results and submitting them in approved formats etc.

e) The quoted rates for trial pits/plate load tests/ cyclic plate load tests shall be inclusive of dewatering and backfilling etc.

f) The quoted rates for drilling in rock shall satisfy the requirements as furnished in specification.

g) The rates quoted for conducting pump out test shall be inclusive of boring a well of 400mm diameter, providing and installation of perforated GI/MS pipes and observation pipes etc .

h)The rates quoted for conducting cross hole shear test shall be inclusive of necessary boring, providing PVC pipes, grouting, geophones, backfilling the holes after completion of testing etc.

i)The rates quoted for laboratory tests shall include preparation of samples, performing tests, recording, analysis and submission of data etc.



STANDARD SPECIFICATION  
FOR  
GEOTECHNICAL INVESTIGATION

SPEC. NO. PE-TS 999-603-002

VOLUME II

SECTION D

REV. NO. 0 DATE 11.06.2009

SHEET 46 OF 50

j) The bidder shall submit a scheme showing the arrangement and equipment proposed to be used for conducting the site work along with rates. However the minimum number of staff and equipments to be deployed/mobilised for site works shall be as per **Annexure-C & D** respectively.

## 10.2 MEASUREMENTS

a) All measurements shall be in SI Units.

b) Length shall be measured in metres (m) correct to two places of decimals. Areas shall be worked out in square meters(Sqm) and volume in cubic meters(Cum) rounded off to two decimals.

c) Certain tests have to be conducted in the bore holes and trial pits etc. Such bore holes and trails pits etc shall be measured once only and not again just because the tests are conducted therein.

d) The depth of penetration due to SPT at the bottom of bore hole shall not be considered for the measurement of bore hole depth.

e) Pits shall be measured in Cum.

f) Coring in rock with diamond bit shall be measured in length(metre) correct to two places of decimal for the actual cored length satisfying the criteria of specification.





STANDARD SPECIFICATION  
FOR  
GEOTECHNICAL INVESTIGATION

SPEC. NO. PE-TS 999-603-002

VOLUME II

SECTION D

REV. NO. 0 DATE 11.06.2009

SHEET 48 OF 50

**ANNEXURE-B**

**SUMMARY OF LABORATORY TEST RESULTS**  
**ON ROCK CORE SAMPLES**

BORE HOLE NO.	
DEPTH	
CORE PIECE NO.	
MOISTURE CONTENT	
SPECIFIC GRAVITY	
HARDNESS	
POROSITY	
DRY DENSITY	
SLAKE DURABILITY	
POINT LOAD STRENGTH INDEX	
DEFORMABILITY (DRY /SATURATED)	
UNCONFINED COMPRESSIVE STRENGTH ( INSITU/SATURATED)	
CORE DESCRIPTION	
REMARKS	



STANDARD SPECIFICATION  
FOR  
GEOTECHNICAL INVESTIGATION

SPEC. NO. PE-TS 999-603-002

VOLUME II

SECTION D

REV. NO. 0 DATE 11.06.2009

SHEET 49 OF 50

**ANNEXURE-C**

**MINIMUM STAFF TO BE DEPLOYED**

<b><u>S.No.</u></b>	<b><u>Description</u></b>	<b><u>No. of persons</u></b>
1.	Geotechnical Engineer	To be filled by respective BHEL Power Sector Region project wise considering the project schedule and actual scope of work
2.	Engineering Geologist	
3.	Supervisor	
4.	Qualified Surveyor	
5.	Rig Operators	
6.	Mechanic	



STANDARD SPECIFICATION  
FOR  
GEOTECHNICAL INVESTIGATION

SPEC. NO. PE-TS 999-603-002

VOLUME II

SECTION D

REV. NO. 0 DATE 11.06.2009

SHEET 50 OF 50

**ANNEXURE-D**

**LIST OF EQUIPMENTS TO BE MOBILISED TO SITE (MINIMUM)**

<b><u>S.No.</u></b>	<b><u>Description</u></b>	<b><u>Quantity</u></b>
1	Shell and auger boring set	To be filled by respective BHEL Power Sector Region project- wise considering the project schedule and actual scope of work
2.	Rotary core drilling unit (Hydraulic feed)	
3.	Static cone penetration test equipment - 20T capacity	
4.	Dynamic cone penetration test equipment	
5.	Plate load test set up	
6.	Field permeability test set up	
7.	Menard pressuremeter or equivalent set up with limit pressure of 80kg/sq.cm.	
8.	Seismic refraction test set up	
9.	Electrical resistivity test set up	

**Note:**

Additional equipments shall be mobilized if required as per the directions of the engineer-in-charge to match the work schedule.

# **1X660 MW PANKI TPS EXTENSION**

## **TECHNICAL SPECIFICATION FOR TOPOGRAPHICAL SURVEY**

**SPECIFICATION NO PE-DC-K57-601-C001**

**VOL - II**



**PROJECT ENGINEERING MANAGEMENT  
POWER PROJECT ENGINEERING INSTITUTE,  
HRD & ESI COMPLEX,  
PLOT NO.: 25, SECTOR-16A,  
NODIA, - 201 301, (UP)**



**STANDARD SPECIFICATION FOR  
TOPOGRAPHICAL SURVEY OF  
1X660 MW PANKI TPS EXTENSION**

SPEC. NO.	PE-DC-K57-601-C001		
VOLUME	II		
SECTION	D		
REV. NO.	0	DATE	25/04/2016
SHEET	1	OF	11

**STANDARD SPECIFICATION  
FOR  
TOPOGRAPHICAL SURVEY**

**1.0 GENERAL**

1.1 This specification covers the technical requirements for carrying out “**Topographical Survey and Allied Works**” for the entire area/areas indicated for locating the power plant and its other systems. The work shall be executed in accordance with the specification and good standard of practice necessary to fulfil the objectives of the survey work strictly in accordance with the instruction and satisfaction of the engineer-in-charge.

**2.0 SCOPE**

2.1 The scope of work includes the following.

2.1.1 Carrying out topographical survey and preparation of plans (maps) and report of the entire area/areas indicated for locating the power plant and its other systems.

2.1.2 Carrying out bench mark ( GTS / any other reference bench mark approved by the engineer-in-charge) to site/sites under survey by parallel levelling, establishing and constructing bench mark, grid and reference pillars in the field.

2.1.3 Spot level survey of the entire area/areas at specified intervals and development of contours.

2.1.4 Carrying out cross-section of canal/nallah as specified in the schedule of quantities by taking spot levels at 5m interval or less depending upon the site conditions and instructions of the engineer-in-charge.

2.1.5 Providing survey instruments, construction equipments, tools & plants, materials, labours, qualified surveyors, clearance of jungles, cutting of trees, earth work, scaffoldings, transport, supervision by competent engineers/surveyors, testing of materials, full insurance and all other incidental items as may be necessary for successful completion of the surveying , mapping and construction works etc.



**STANDARD SPECIFICATION FOR  
TOPOGRAPHICAL SURVEY OF  
1X660 MW PANKI TPS EXTENSION**

SPEC. NO.	PE-DC-K57-601-C001		
VOLUME	II		
SECTION	D		
REV. NO.	0	DATE	25/04/2016
SHEET	2	OF	11

- 2.1.6 Furnishing all field data and drawings on floppies apart from hard copies.
- 2.1.7 Furnishing survey report as described in details in the succeeding paragraphs is also included in the scope of work.

### **3.0 TENDER DRAWING**

- 3.1 The enclosed Topographical Survey & Geotechnical Investigation Layout (**Drg. No. PE-DG-K57-601-C001**) indicate the tentative location of the area/areas to be surveyed for locating the project. The location/area(s) indicated in the drawing is subject to change that may be necessary during actual execution of the work. The work shall be carried out as per the instructions of the engineer-in-charge.
- 3.2 The bidder must visit the site prior to submitting his quotations to acquaint himself fully with the nature, type, scope of work and involvement therein. The rates quoted shall remain firm during the entire period of execution till completion of the work and any additional claim for lack of knowledge shall not be entertained.

### **4.0 SPECIFICATION**

- 4.1 The work shall be executed according to the specification and good standard of practice necessary to fulfil the objectives of the survey work strictly in accordance with the instruction and satisfaction of the engineer-in-charge.
- 4.2 The specification shall be read in conjunction with the description of items in the schedule of quantities. The bidder shall refer to the employer for any discrepancy which may exist between the drawings, specification and corresponding items of the schedule for clarification before submission of quotation and the employer's decision as to the clarity of the point raised shall be final and binding on the bidder.
- 4.3 The work at site shall be carried out under the full time supervision by a qualified engineer or a senior surveyor. The engineer or senior surveyor shall be responsible for and capable of co-ordinating the work of the surveying teams, setting out the work accurately, identifying immediately and positively the type of instruments to be deployed and the



**STANDARD SPECIFICATION FOR  
TOPOGRAPHICAL SURVEY OF  
1X660 MW PANKI TPS EXTENSION**

SPEC. NO.	PE-DC-K57-601-C001		
VOLUME	II		
SECTION	D		
REV. NO.	0	DATE	25/04/2016
SHEET	3	OF	11

methodology of surveying to achieve speed and accuracy in the work and shall be fully conversant with the theory and techniques of traversing, triangulation, spot levelling survey work etc covered by this contract.

4.4 The contractor shall be responsible for the proper execution of the work to such lines and grades as specified in the specification, drawings or as directed by the engineer-in-charge from time to time.

4.5 After arrival of the instruments to site, these shall not be moved out of the site by the contractor without the prior written permission and approval of the engineer-in-charge. In case the instruments are moved out of the site without the prior written permission and approval, the engineer-in-charge/owner reserves the right to deduct from the contractor's bill(s) the amount as considered reasonable and or to withheld the payments for the work done. The decision of the engineer-in-charge in this regard shall be final and binding on the contractor.

**5.0 CARRYING OUT AND SETTING UP OF BENCH MARK & REFERENCE PILLARS**

5.1 The contractor shall carry out bench mark by fly-levelling from the nearest GTS bench mark or available source as approved by the engineer-in-charge and establish the same on a permanent bench mark to be constructed as per **Fig.1** at a convenient location(s) at site as per the instructions of the engineer-in-charge. All subsequent transfer of levels shall be carried out with respect to this bench mark.

5.2 The work shall also include constructing permanent reference pillars as per **Fig.2** at suitable locations as approved by the engineer-in-charge. These reference pillars shall be labelled permanently with their respective co-ordinates and reduced levels for future use. The bench mark and reference pillars shall be shown on the survey drawings.

5.3 The fly levelling should be carried out using two good quality levels simultaneously. The levelling instruments should always be kept free of collimation error which should be checked and adjusted before start of the work every day. A record of adjustments should be kept in the field book.



**STANDARD SPECIFICATION FOR  
TOPOGRAPHICAL SURVEY OF  
1X660 MW PANKI TPS EXTENSION**

SPEC. NO.	PE-DC-K57-601-C001		
VOLUME	II		
SECTION	D		
REV. NO.	0	DATE	25/04/2016
SHEET	4	OF	11

5.4 While carrying bench mark to the project site, levels shall be established on the permanent objects like culverts etc at least on one object in every 500m along the route with adequate description about the objects and levels to be mentioned in the level book/survey report to facilitate locating these objects later on. The route for transferring levels shall follow the existing roads as far as possible and this route shall require the approval of the engineer-in-charge before the commencement of work.

5.5 Closing error in levelling should be limited to  $12 \sqrt{L}$  mm, where L is the length of the route in km.

5.6 Payment shall be made on the basis of shortest length of the said route measured between the original reference bench mark and the bench mark to be established at site.

## **6.0 TOPOGRAPHICAL SURVEY AND MAPPING**

6.1 Positions both in plan and elevation of all natural and artificial features of the area like waterways, railway tracks, trees, cultivation, houses/any structure, fences, pucca and kutcha roads including culverts and crossings, foot tracks, other permanent objects like telephone posts and transmission towers etc are to be established and subsequently be shown on survey maps by means of conventional symbols (preferably symbols of Survey of India maps). All earth deposits, depressions, hills and valleys within the area/areas are to be surveyed and plotted on maps by contours. Necessary levelling work of the entire area/ areas are to be surveyed and plotted on maps by establishing horizontal location so that location and sketching of contours for the area/ areas can be done at specified intervals and in specified scales on maps. In case of steep slopes and dense jungle etc where gridding is not possible, the method of survey, contour intervals etc shall be decided by the engineer-in-charge at site. Any unusual condition or formations on the ground, location of rock outcrops and springs/falls etc shall also be noted and plotted on the maps.

6.2 The field work shall be done with total station equipment in the following steps.

- i) Establishing horizontal and vertical controls and locating reference grids and bench mark in the area.



**STANDARD SPECIFICATION FOR  
TOPOGRAPHICAL SURVEY OF  
1X660 MW PANKI TPS EXTENSION**

SPEC. NO.	PE-DC-K57-601-C001		
VOLUME	II		
SECTION	D		
REV. NO.	0	DATE	25/04/2016
SHEET	5	OF	11

ii) Surveying for establishing spot levels and plotting contours.

iii) Surveying for locating natural and man made details as described earlier.

6.3 The grids for the survey work shall be established in N-S & E-W direction corresponding to magnetic north or the plant north as directed by the engineer-in-charge.

## **7.0 TRAVERSING**

7.1 Triangulation or traversing or a combination of both shall be adopted for the purpose of establishing horizontal control and in order to determine the exact relationship between various existing points on the ground so that surveys required under the present scope of work and in future may be co-related and tied together.

7.2 Total intelligent station instruments should be deployed to achieve the specified accuracy of the work. Proper precautions for avoiding graduation errors, instrumental and personal errors should be scrupulously observed.

7.3 From main traverse/triangulation station, subsidiary stations shall be established at suitable interval to cover the entire area. Level of these stations shall be based on the bench mark established in the survey area. Occupying the main & subsidiary stations, all major details shall be surveyed by total station equipment. Further classification of details if necessary shall be carried out by plane table method.

7.4 The closing error in traverse shall not exceed one in twenty five thousand (1 in 25000) in terms of length or  $L\sqrt{N}$  seconds (total in angular measurement) whichever is less (where L is the least count of the instrument and N is the number of stations).

## **8.0 CONTOURING**

8.1 Contractor shall carry out spot level surveying at an interval of 5m for contouring the area/areas. Levels shall also be taken on all traverse stations and on salient points located at random over the area (ground points). Contours are to be interpolated at 0.25m intervals after the above



**STANDARD SPECIFICATION FOR  
TOPOGRAPHICAL SURVEY OF  
1X660 MW PANKI TPS EXTENSION**

SPEC. NO.	PE-DC-K57-601-C001		
VOLUME	II		
SECTION	D		
REV. NO.	0	DATE	25/04/2016
SHEET	6	OF	11

points are plotted. The contours shall not be just interpolated but properly surveyed on the ground so that features falling between the two successive levels are also picked up. Sufficient points properly distributed over the entire area shall be located and levels taken so that accurate contouring can be done. At places of sharp curvature or abrupt change in direction and elevation, points selected shall be close to each other. Salient points on ridge lines and valley lines shall also be measured.

- 8.2 Cross-section of canal/nallah if any shall be prepared by taking spot levels at 5m interval or less depending upon the site conditions and instructions of the engineer-in-charge. For contouring within reservoirs /ponds sounding technique shall be adopted.
- 8.3 Levelling operation shall always start from main/subsidiary stations whose levels are based on the bench mark established in the survey area and end on the same.
- 8.4 Closing error in levelling shall not exceed the limit mentioned in clause 5.5.

**9.0 CONSTRUCTION OF BENCH MARK, REFERENCE & GRID PILLARS**

- 9.1 Bench marks shall be constructed as per the sketch at **Fig - 1** for each isolated area as per the directions of the engineer-in-charge. The reduced level of the top of hemispherical ball and co-ordinates with respect to survey grid shall be engraved clearly on the top of the bench mark pillar. The top surface of MS plate alongwith the hemispherical ball shall be painted with anticorrosive paint.
- 9.2 There shall be one reference pillar constructed within one meter of each bench mark pillar as per the sketch at **Fig - 2**. The relation of these pillars with respect to the bench mark pillar and survey grids should be established and indicated in the drawings. The reduced levels and co-ordinates should be transferred & punched on the top of the steel plate of reference pillars. The top surface of MS plate shall be painted with anticorrosive paint.



**STANDARD SPECIFICATION FOR  
TOPOGRAPHICAL SURVEY OF  
1X660 MW PANKI TPS EXTENSION**

SPEC. NO.	PE-DC-K57-601-C001		
VOLUME	II		
SECTION	D		
REV. NO.	0	DATE	25/04/2016
SHEET	7	OF	11

9.3 Grid pillars as per the enclosed sketch at **Fig - 2** shall be constructed at the intersection of the 200m grid lines which should be established at site in N-S and E-W direction corresponding to magnetic north or plant north or as directed by the engineer-in-charge and their co-ordinates with reference to the survey grids shall be engraved on the top of the pillars. The top surface of MS plate shall be painted with anticorrosive paint. The pillars should be white washed.

9.4 The payment shall be made on the number of bench mark and reference/grid pillars actually constructed at site as per the directions of the engineer-in-charge.

### **10.0 Route Survey**

10.1 Route Survey shall be conducted along a narrow strip/belt of the terrain selected after field reconnaissance or as directed by Owner/Engineer at Site. Topographical survey for existing storm drainage lines as well as for routing pipe lines, transportation and communication lines, etc. shall be conducted. Longitudinal profiles as well as cross-sections shall be taken at 50 m intervals or less in nearly flat/undulating terrains and at 20 m intervals in hilly terrains, as per direction of the Owner/Engineer. All cross-sections shall be with reference to centre line of corridor showing levels at every 2 - 5 metre intervals and all breaks in the profile. The width of strip/corridor shall be as specified in the drawing or as directed by Owner/Engineer.

### **11.0 PROGRESS REPORT**

11.1 The contractor shall prepare and submit progress report in three copies every week to the engineer-in-charge without fail indicating status of setting out of the grids, total area surveyed, grid pillars constructed, methodology adopted for surveying and instruments deployed including staff working on the site and difficulties encountered during execution of the work etc.

11.2 The submission of such reports and review thereof by the engineer-in-charge shall not be deemed to absolve the contractor of his responsibility of timely completion of the assignment as per the time schedule indicated.



**STANDARD SPECIFICATION FOR  
TOPOGRAPHICAL SURVEY OF  
1X660 MW PANKI TPS EXTENSION**

SPEC. NO.	PE-DC-K57-601-C001		
VOLUME	II		
SECTION	D		
REV. NO.	0	DATE	25/04/2016
SHEET	8	OF	11

**12.0 PREPARATION & SUBMISSION OF SURVEY MAPS**

12.1 The contractor shall submit survey maps of the site in 1:1000 scale indicating grid lines and contour lines, demarcating all permanent features like roads, railways, waterways, buildings, power lines, natural streams, trees etc. Project area should have two originals, one showing spot levels and contours (with contour line interval of 0.25m) with grid lines and other with grid lines, contour lines and permanent features.

12.2 All the maps should be prepared in digitised forms using Inkjet/Pen plotter and standard computer software like Autocad - 12/13/14 or auto civil on standard A-0 size polyester base film. The block of name plate of all the drawings should be as per BHEL standard.

12.3 The contractor shall submit three copies of all the maps for review and approval of the engineer-in-charge. After approval, 6(six) prints of all the final maps alongwith a set of the originals on polyester base film and a floppy shall be submitted. Copies of the maps shall be submitted in proper flappers and original polyester base drawings should be handed over in proper card board covers indicating index of drawings.

12.4 Payment shall be made on the area actually surveyed as covered by the plan.

**13.0 SUBMISSION OF FIELD DATA AND REPORT**

13.1 Contractor shall submit all data pertaining to the survey in original to the engineer-in-charge.

13.2 All field data shall be submitted to the engineer-in-charge from time to time as per progress of the work.

13.3 Three copies of draft report shall be submitted on the completion of the field work for review and approval of the engineer-in-charge. The report should give the introduction of the site, methodology adopted for surveying the areas, calculation of errors, transfer of bench mark and any other calculation required for surveying and preparation of the survey maps.



**STANDARD SPECIFICATION FOR  
TOPOGRAPHICAL SURVEY OF  
1X660 MW PANKI TPS EXTENSION**

SPEC. NO.	PE-DC-K57-601-C001		
VOLUME	II		
SECTION	D		
REV. NO.	0	DATE	25/04/2016
SHEET	9	OF	11

13.4 Details of trees with their name, numbers and girths shall also form part of the survey report.

13.5 The survey report should also cover the following.

- General site observation such as location of access roads, river and nallah courses, irrigation canals etc.
- Presence of any well and /or tube well in the site and water level in them shall also be indicated.
- Whether there is any rock outcrops in the site.
- Existing drainage pattern of the site, possibility of water logging and high flood level of the area.

13.6 Final survey report shall be submitted in 6 copies of standard A4 size sheets properly bound and printed using good quality paper and material.

#### **14.0 CLEARANCE OF JUNGLES AND CUTTING OF TREES**

Clearance of jungles and cutting of trees as required to facilitate the survey work also form part of the contract. Necessary permission of concerned public bodies shall be secured by the owner. The contractor shall ensure that minimum amount of jungles are cleared and trees are properly cut under the direction of public bodies. The trees and jungles as cleared shall be stacked and handed over to the engineer-in-charge/owner. No extra payment is admissible under this account.

#### **15.0 INSPECTION**

The contractor shall make all arrangements of men, material, instruments, surveyors, necessary records and field data etc at the work site for checking of the work to the satisfaction of the engineer-in-charge or his authorised representative during the progress and on successful completion of the work. The contractor shall intimate well in advance before final decamping from work site so that the final work can be inspected by the engineer-in-charge. This will form a part of acceptance of the work for release of payments.

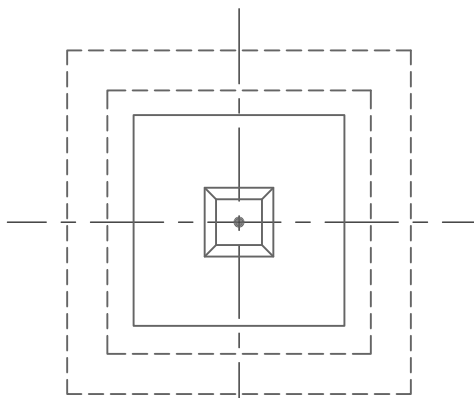

**VIEW 1-1**

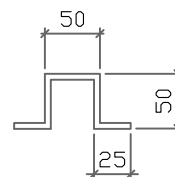

**LUG DETAILS**

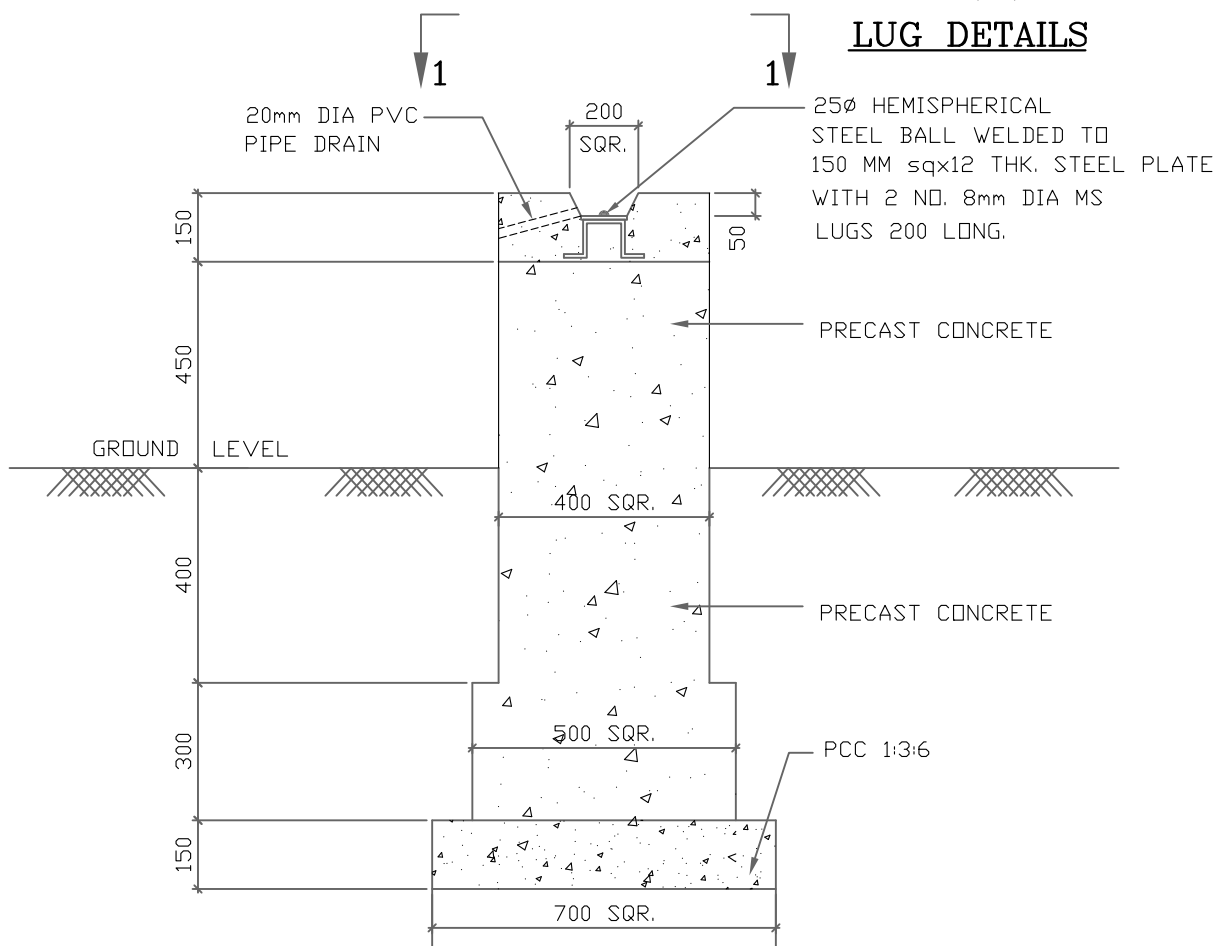

**FIG. 1  
 BENCH MARK PILLAR**

**NOTES**

1. ALL DIMENSIONS ARE IN MM
2. ALL MATERIALS AND WORKMANSHIP SHALL BE AS PER SPECIFICATION & RELEVANT IS CODES



COPY RIGHT AND CONFIDENTIAL  
 The information on this document is the property of BHARAT HEAVY ELECTRICALS LIMITED  
 It must not be used directly or indirectly in any way detrimental to the interest of the company.

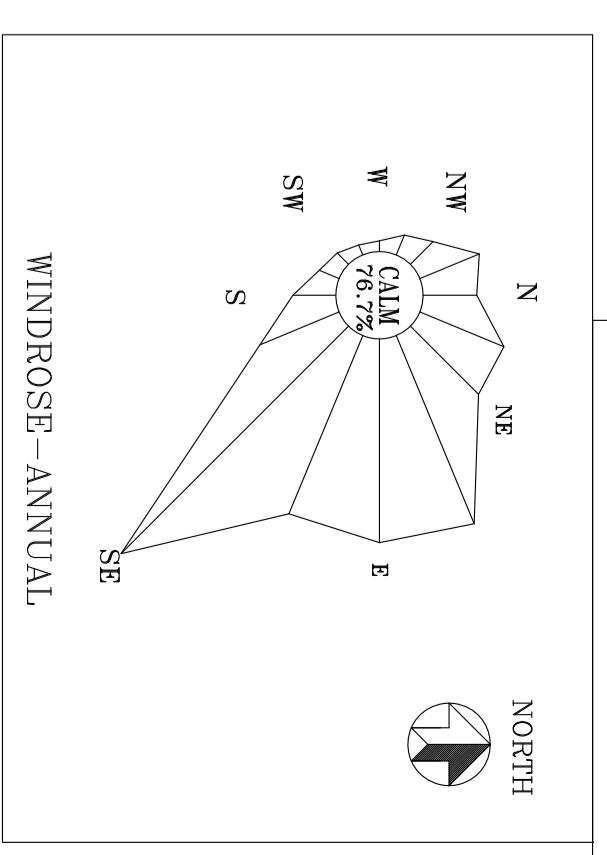
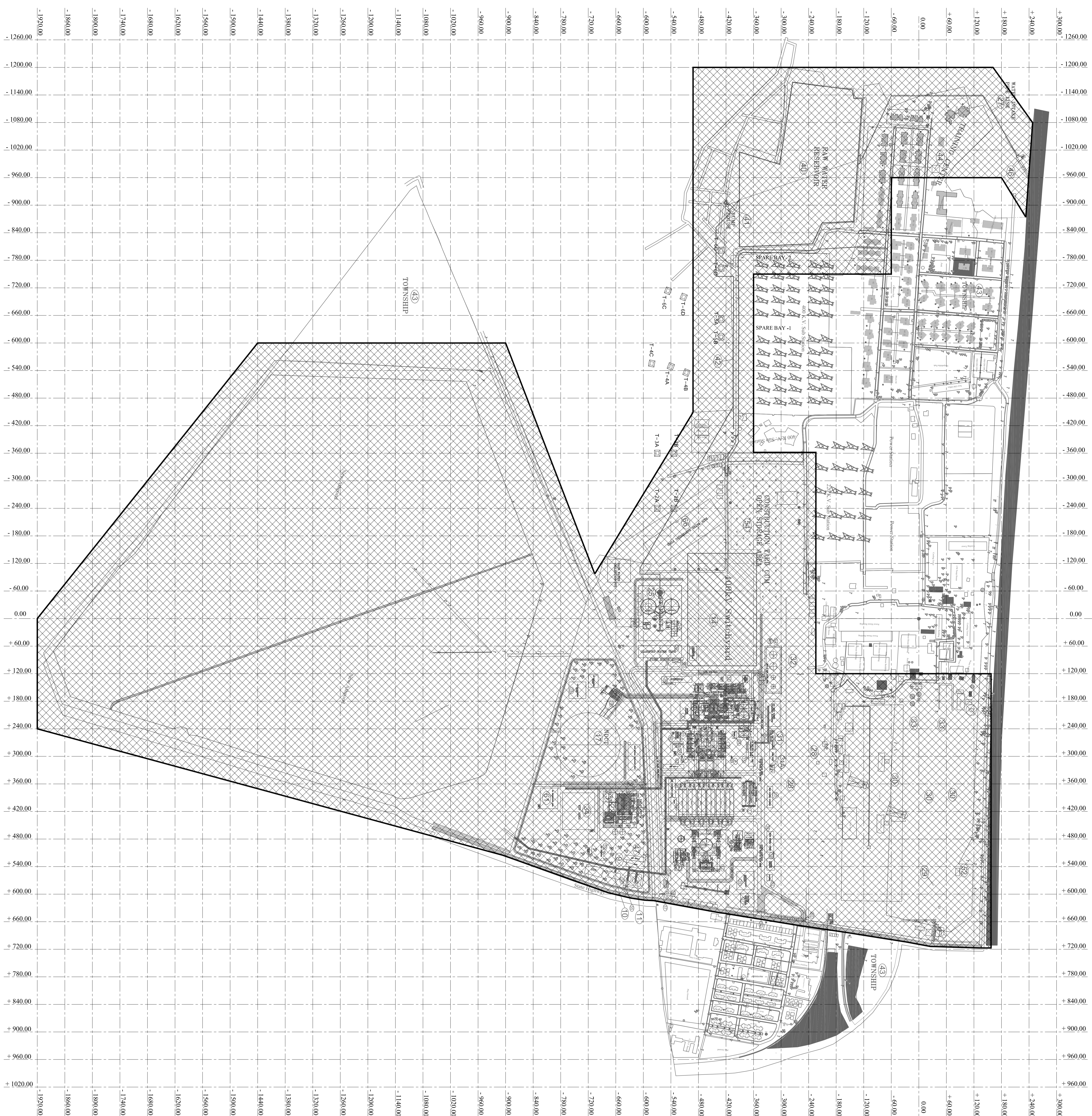

- NOTES:-**
1. AREA MARKED FOR TOPOGRAPHICAL SURVEY AND GEOTECHNICAL INVESTIGATION IS INDICATIVE ONLY. THE EXACT LOCATION FOR TOPOGRAPHICAL SURVEY AND GEOTECHNICAL INVESTIGATION SHALL BE FURNISHED DURING EXECUTION.
  2. TOPOGRAPHICAL SURVEY SHALL BE CARRIED OUT AS PER SPECIFICATION NO. PE-DG-K57-601-C001.
  3. GEOTECHNICAL INVESTIGATION SHALL BE CARRIED OUT AS PER SPECIFICATION NO. PE-TS-999-603-002.

**REFERENCE DRAWING:-**  
 DRAWING NO. PE-DG-K57-100-M001 TILED "PLOT PLAN", REV.-00.

**LEGEND:-**  
 AREA FOR TOPOGRAPHICAL SURVEY & GEOTECHNICAL INVESTIGATION

TENDER PURPOSE ONLY

REV	DATE	ACTD	CRD	APPD	REV	DATE	ACTD	CRD	APPD

CUSTOMER	UPRVNL
CONSULTANT	DEVELOPMENT CONSULTANTS PVT. LTD., KOLKATA
PROJECT	1X660MW PANKI TPS EXTN.
JOB NO.	K57
STATUS	PROPOSAL
DISTRIBUTION	
PROJECT	BHARAT HEAVY ELECTRICALS LTD POWER SECTOR PROJECT ENVIRONMENTAL MANAGEMENT KOLKATA

TITLE	TOPOGRAPHICAL SURVEY & GEOTECHNICAL INVESTIGATION LAYOUT
SCALE	AS SHOWN
SHEET	1 OF 3