

Tender Enquiry No. 2890/C/6410/2023/4312/T1 for VERTICAL CNC 5 AXIS MILLING MACHINE-01 No.

BHARAT HEAVY ELECTRICALS LIMITED

HEEP: HARDWAR-249 403 (UA)

Fax : +91 1334-226462, Phone : +911334-281961 ; Mobile : +91 9997459201

E-mail: ashishkumar.keshari@bhel.in

No. Cap/Domestic/2024-25

Date: 21 -May-2024

Subject: Tender as detailed below:

DOMESTIC TENDER ENQUIRY

1. Sealed tenders with the Tender No. and opening date clearly super scribed on the cover are invited for the supply of the following items.
2. Last date for obtaining tender documents and opening of tenders is indicated against each tender. Tenders will be received up to 1.45 P.M. on opening date and opened on the same day at 2.00 P.M. in the Tender Room.
3. After downloading the tender documents from web site, while submitting the tender as detailed in "Instruction to Bidders", intending vendors must remit the requisite EMD in the form of Electronic Fund Transfer in favour of BHEL account/Banker's cheque/Pay Order / Demand draft in favour of BHEL / Fixed Deposit Receipt (FDR)/Bank Guarantee from any of scheduled banks/Insurance Surety Bonds.
4. BHEL will not be responsible for any type of postal delay / incomplete information from vendor.
5. Other terms and conditions will be as per tender documents.

Sl. No.	Tender No.	Description of Equipment	Qty. (No.)	Last date to submit offer in BHEL HEEP Tender Room	Opening date
1.	2890/C/6410/2023/4312/T1	VERTICAL CNC 5 AXIS MILLING MACHINE	01	20-June - 2024; 01:45 PM	20-June - 2024; 02:00 PM

- Technical & Financial PQR enclosed.
- Technical specifications enclosed.
- Test Certificate required.
- Operation and Maintenance Manual Required.
- GST Input Tax credit available.
- User Manuals required for all equipment as applicable.
- Guarantee certificate is required for two years (for complete machine and attachment/accessories) after successful commissioning.
- Pre-dispatch inspection is required & vendor shall inform to BHEL at least 45 days before the date of pre-dispatch inspection.
- Early Delivery is not acceptable.
- Recommended Spares are required.
- Erection & Commissioning is required at BHEL Haridwar.
- Erection & Commissioning charges are 5 % of equipment cost.
- E&C Milestone 1: Errection & Commissioning: - Time period shall be 15 weeks from the date of first intimation given by BHEL Haridwar.
- E&C: Milestone 2: Job Proveout: - Time period shall be 17 weeks from the date of first intimation given by BHEL Haridwar

Tender Enquiry No. 2890/C/6410/2023/4312/T1 for VERTICAL CNC 5 AXIS MILLING MACHINE-01 No.

- Participating bidders are requested to reply against each and every point of Technical Specification, PQR and Commercial terms and conditions.
- Wherever Service charges like Supervision, Inspection, etc. consequent or incidental to supply are envisaged in tender, such charges should not exceed 2% of the total contract value. It is recommended that such charges be sought on per visit/per day basis, and the evaluation of the tender is to be done including the cost of the service charges.

For & ON BEHALF OF BHEL, HARDWAR /AGM (Capital Purchase)

Tender Enquiry No. 2890/C/6410/2023/4312/T1 for VERTICAL CNC 5 AXIS MILLING MACHINE-01 No.

BHARAT HEAVY ELECTRICALS LIMITED

HEEP: HARDWAR-249 403 (UA)

Fax : +91 1334-226462, Phone : +911334-281961 ; Mobile : +91 9997459201

E-mail: ashishkumar.keshari@bhel.in

No. Cap/Domestic/2024-25
M/s

Date: 21 -May-2024

Sub: Domestic Tender Enquiry No. 2890/C/6410/2023/4312/T1

We are pleased to invite your offer in **TWO PARTS (PART-I & PART-II)** strictly as per enclosed terms and conditions and “Instruction to Bidders”, in sealed covers for the under mentioned equipment / systems.

Sl. No.	Description of Equipment	Qty. (No.)	Delivery Required	EMD (Earnest Money Deposit)
1.	VERTICAL CNC 5 AXIS MILLING MACHINE	01	14.10.2026	Rs. 40,00,000/-

Please submit your lowest quotation / offer for the above requirement subject to our terms and conditions. Your offer should reach us on or before the due date by 1.45 PM.

NOTE: The vendors should submit their best price at this stage itself and they will not be allowed to revise the price. Any revision / discount given by vendor subsequently will be ignored.

Any clarification on technical specifications can be obtained from BHEL Haridwar before tender opening. Vendors to note the following points about **pre-bid meeting**:

- Pre-bid meeting to be held at BHEL Haridwar & no video conferencing will be held.
- Attending pre-bid meeting is mandatory as offers of only those vendors would be evaluated who have attended pre-bid meeting and signed MOM.
- Vendors will be required to sign NDA for participating in pre-bid meeting.
- Vendors to ensure that their technical experts or authorized representatives will present in pre-bid meeting for evaluating prove out component.
- Vendor to ensure their participation in pre-bid meeting at BHEL Haridwar as per their convenience before submission of their bid.

PURCHASE PREFERENCE TO MAKE IN INDIA

For this procurement, Public Procurement (Preference to Make in India), Order 2017 dated 04.06.2020 & revision dated 16.09.2020 and subsequent Orders issued by respective Nodal Ministry shall be applicable even if issued after issue of this Tender Enquiry but before finalization of contract/ PO/ WO against this tender enquiry.

As per clause 3(b) of Make in India circular dated 16.09.2020, only Class-I Local supplier and Class -II local supplier as defined under the order, shall be eligible to bid in procurements undertaken by procuring entities being domestic tender. Non - Local suppliers as per MII order dated 04.06.2020 are not eligible to participate.

Purchase preference to Micro and Small Enterprises (MSEs):

Purchase preference will be given to MSEs as defined in Public Procurement Policy for Micro and Small Enterprises (MSEs) Order, 2012 dated 23.03.2012 issued by Ministry of Micro, Small and Medium Enterprises and its subsequent Orders/Notifications issued by concerned Ministry. If the bidder wants to avail the Purchase preference, the bidder must be the manufacturer of the offered product in case of bid for supply of goods. Traders are excluded from the purview of Public Procurement Policy for Micro and Small Enterprises. Relevant documentary evidence in this regard shall be uploaded along with the bid in respect of the offered product.

If L-1 is not an MSE and MSE Seller (s) has/have quoted price within L-1+ 15% (Selected by Buyer) of margin of purchase preference /price band defined in relevant policy, such Seller shall be given opportunity to match L-1 price and contract will be awarded for 100% (selected by Buyer) of total quantity.

EMD (EARNEST MONEY DEPOSIT): EMD shall be applicable for this tender of **Rs. Forty Lacs** Only.

EMD shall be waived off in following cases:

- Micro and Small Enterprises (MSEs) or Startups as recognized by Department for Promotion of Industry and Internal Trade (DPIIT).
- Central/ State PSUs/ Government deptts/ Autonomous/ Educational/Research institutions.
- Joint Venture or Subsidiary companies of BHEL.

Please note that EMD by the tenderer shall be forfeited as per Tender Documents if, the successful bidder/vendor refuses to honor the order after award of the same or him and/or withdraws his bid and/or unilaterally changes the offer and/or any of its terms & conditions within the validity period.

EMD given by the unsuccessful tenderer shall be refunded on acceptance of award / LOI/ PO by successful tenderer. The EMD of successful bidder shall be returned after submission of Contract execution bank guarantee. EMD shall be not carry any interest.

The EMD will be accepted only in the following forms:

- (i) Electronic Fund Transfer credited in BHEL account (before tender opening).
- (ii) Banker's cheque/ Pay order/ Demand draft, in favour of BHEL (along with offer) .
- (iii) Fixed Deposit Receipt (FDR).
- (iv) Bank Guarantee from any of the Scheduled Banks.
- (v) Insurance Surety Bonds.

PLEASE SUBMIT EMD IN PART- I BID. This Part–I bid shall be opened by BHEL at 02:00 PM on the due date, in the presence of authorized representatives of the bidders who may like to be present. The authorized representative should bring authority letter from their principals for attending the bid opening.

BHEL Bank Details for e-remittances of EMD by bidders:

**Tender Enquiry No. 2890/C/6410/2023/4312/T1 for VERTICAL CNC 5 AXIS MILLING
MACHINE-01 No.**

ACCOUNT HOLDER NAME: BHARAT HEAVY ELECTRICALS LIMITED, HEEP, HARIDWAR
STATE BANK OF INDIA
RANIPUR BRANCH,
OPP: BHEL MAIN GATE,
SECTOR-5, RANIPUR,
HARIDWAR, UTTRAKHAND, INDIA
PIN CODE : 249403

SWIFT NO : SBININBB225
CC ACCOUNT NO : 10667995458
IFSC CODE : SBIN0000586

For & ON BEHALF OF BHEL, HARDWAR / AGM (Capital Purchase)

Instruction to Bidders

Clause 1.0 – Tender submission

The tenders have to be submitted in **TWO PARTS (Envelopes)** as described below on or before the due date and time of tender opening:

- a) Part-I (Envelope I) : 1. EMD
 2. Pre-Qualifying Requirement (PQR)

 3. Techno-Commercial Bid.
- b) Part-II (Envelope II) : Price Bid.

Any corrections / amendments shall be properly & fully authenticated with signature.

BHEL will deal directly with the manufacturers / principal vendors and no correspondence with the agents will be entertained. The agents will not be permitted to visit / interact with BHEL on behalf of their principals. Subsequently also, no correspondence of any type will be made with any agent. (All individuals / companies - representing / Advisor /retainership basis or claimed to be part time employees for many OEMs / claiming to be channel or business partner for BHEL work / stockist not registered specifically etc. are Agents). Communications with only those agents who have submitted agency agreement with their respective principal may be done.

Agents shall not be allowed to represent more than one manufacturer / supplier in the same tender. Moreover, either the agent could bid on behalf of the manufacturer / supplier or the manufacturer / supplier could bid directly but not both. In case bids are received from both, the manufacturer / supplier and the agent, bid received from the agent shall be ignored.

The bidders (original manufacturers) will have to submit ink-signed offer/ bid in original directly to BHEL. **Unsigned bids shall be ignored.**

The suppliers or their authorized person may be allowed to attend the tender opening, if duly authorized by their principals, through a specific letter for a particular enquiry for specific price bid opening on that particular day. General authorization letter is not acceptable.

Clause 1.1

The Techno-commercial offer and PQR in envelope - I (Part-I) shall comprise of following:

- i) Point wise reply to all the points mentioned in Pre- Qualifying Requirement specified in the tender.
- ii) Relevant documents as requested in Pre-Qualifying Requirement must be attached.
- iii) Complete Technical offer.
- iv) Catalogue of the Equipment, Complete reference of the past supply of equipment for the same or similar specification giving details of customer with Name of the contact person, Fax no, phone no, E-mail if available.
- v) Acceptance of commercial terms by vendor as per **Annexure I**.
- vi) Deviation with reference to specification to be laid down on separate sheet.

Tender Enquiry No. 2890/C/6410/2023/4312/T1 for VERTICAL CNC 5 AXIS MILLING MACHINE-01 No.

Cost of deviation is to be submitted along with the price bid essentially. In case vendor withdraws the deviation clauses the same will be considered for final evaluation,
vii) Copy of price Bid (without prices).
viii) Any additional documents (please specify).

While submitting the offer, following points are to be taken care of by the vendor:

- **Documents submitted with the offer/bid by the bidder (Original Registered Supplier) shall be ink signed and stamped in each page by authorized representative of the bidder.**
- **If the documents are received in soft form, the same should be transmitted through vendor's authorized e-mail to BHEL tender room e-mail id i.e. tendercell.heep@bhel.in followed by the signed and stamped copy of the same documents.**
- **Documents not signed and stamped in each page by the authorized signatory of the bidder, shall not be accepted and considered for evaluation of the bid.**

Clause 1.2

The Price Bid in envelope - II (Part-II) shall comprise of following:

The price Bid (with price) for the complete scope strictly as specified in the price Format attached as Annexure-II. If price bid is not submitted along with Part-I bid, the offer will be rejected out rightly.

Note:

If in a price bid, non-conformities /errors /discrepancies are observed between the quoted prices in figures and that in words the following guidelines will be followed: -

- a) If, in the price structure quoted for the required goods/ services/ works, there is discrepancy between the unit price and the total price (which is obtained by multiplying the unit price by the quantity), the unit price shall prevail and the total price corrected accordingly, unless in the opinion of the purchaser there is an obvious misplacement of the decimal point in the unit price, in which case the total price as quoted shall govern and the unit price corrected accordingly.
- b) If there is an error in a total corresponding to the addition or subtraction of subtotals, the subtotals shall prevail and the total shall be corrected; and
- c) If there is a discrepancy between words and figures, the amount in words shall prevail, unless the amount expressed in words is related to an arithmetic error, in which case the amount in figures shall prevail subject of (a) and (b) above.
- d) If there is such discrepancy in an offer, the same is to be accepted by the bidder by a target date and in case the bidder does not agree to the decision of the purchaser, the bid is liable to be ignored.

Clause 2.0 – Tender Opening:

a) Offer should be complete in all respect (i.e. Part-I & Part-II) as described below:

Part I : Part I bid (Envelope-I) comprising EMD (if applicable) or MSE Certificate/ Startups as recognized by Department for Promotion of Industry and Internal Trade (DPIIT) towards exemption of EMD, Pre- Qualifying Requirement (PQR) and Techno-commercial bid as mentioned above.

Part II : Part II bid (Envelop-II) comprising Price Bid.

Tender Enquiry No. 2890/C/6410/2023/4312/T1 for VERTICAL CNC 5 AXIS MILLING MACHINE-01 No.

b) The tenders shall be opened in **TWO PARTS (Part-I & Part-II)** as described below:

- Part-I containing EMD (if applicable) or MSE Certificate/ Startups as recognized by Department for Promotion of Industry and Internal Trade (DPIIT) towards exemption of EMD, Pre- Qualifying Requirement (PQR) and Techno-commercial bid will be opened on the date and time specified in the tender cover page, in the presence of those vendors, who wish to attend the tender opening.
- Part II containing Price Bid will be opened on a separate date for those vendors who have qualified in the Part I. The opening date of Part II will be intimated in advance to the vendors qualified in Part-I.
- In the event of BHEL calling for supplementary bid, the part-II price Bid along with supplementary priced bid (if necessary) will be opened at a later date of only those bidders who have qualified in the Part I. The opening date of Part II along with supplementary price bid (if necessary) will be intimated in advance to the vendors qualified in Part-I.

BHEL reserves the right to evaluate vendor's process capability / quality systems etc. by visiting vendor works (if required).

Clause No. 3:

As per directives of CENTRAL VIGILANCE COMMISSION, GOVERNMENT OF INDIA, one agent can not represent two or more suppliers or quote on their behalf in a particular tender. If so found at any stage, BHEL Hardwar is likely to cancel Enquiries / POs to such suppliers. Further, such Indian Agent is likely to be de-listed (Black listed for business from BHEL).

Clause No. 4: Conflict of interest among Bidders/Agents

“A bidder shall not have conflict of interest with other bidders. Such conflict of interest can lead to anti-competitive practices to the detriment of Procuring Entity's interests. The bidder found to have a conflict of interest shall be disqualified. A bidder may be considered to have a conflict of interest with one or more parties in this bidding process, if:

- a) They have controlling partner (s) in common; or
- b) They receive or have received any direct or indirect subsidy/financial stake from any of them; or
- c) They have the same legal representative/agent for purposes of this bid; or
- d) They have relationship with each other, directly or through common third parties, that puts them in a position to have access to information about or influence on the bid of another bidder; or
- e) Bidder participates in more than one bid in this bidding process. Participation by a Bidder in more than one Bid will result in the disqualification of all bids in which the parties are involved. However, this does not limit the inclusion of the components/sub-assembly/Assemblies from one bidding manufacturer in more than one bid; or
- f) In cases of agents quoting in offshore procurements, on behalf of their principal manufacturers, one agent cannot represent two manufacturers or quote on their behalf in a particular tender enquiry. One manufacturer can also authorize only one agent/dealer. There can be only one bid from the following:
 - 1. The principal manufacturer directly or through one Indian agent on his behalf; and
 - 2. Indian agent on behalf of only one principal;
- g) A bidder or any of its affiliates participated as a consultant in the preparation of the design or technical specifications of the contract that is the subject of the bid; or
- h) In case of a holding company having more than one independently manufacturing units, or more than one unit having common business ownership/management, only one unit should quote.

Tender Enquiry No. 2890/C/6410/2023/4312/T1 for VERTICAL CNC 5 AXIS MILLING MACHINE-01 No.

Similar restrictions would apply to closely related sister companies. Bidders must proactively declare such sister/common business/management units in same/similar line of business.”

Clause No. 5: Restrictions under Rule 144(xi) of the General Financial Rules (GFRs)

- I. Any bidder from a country which shares a land border with India will be eligible to bid in any procurement whether of goods, services (including consultancy services and non-consultancy services) or works (including turnkey projects) only if the bidder is registered with the Competent Authority. Further, any bidder (including bidder from India) having specified Transfer of Technology (TOT) arrangement with an entity from a country which shares a land border with India, shall also require to be registered with the same competent authority.
- II. "Bidder" (including the term 'tenderer', 'consultant' or 'service provider' in certain contexts) means any person or firm or company, including any member of a consortium or joint venture (that is an association of several persons, or firms or companies), every artificial juridical person not falling in any of the descriptions of bidders stated hereinbefore, including any agency branch or office controlled by such person, participating in a procurement process.
- III. "Bidder (or entity) from a country which shares a land border with India" for the purpose of this Order means: -
 - An entity incorporated, established or registered in such a country; or
 - A subsidiary of an entity incorporated, established or registered in such a country; or
 - An entity substantially controlled through entities incorporated, established or registered in such a country; or
 - An entity whose beneficial owner is situated in such a country; or
 - An Indian (or other) agent of such an entity; or
 - A natural person who is a citizen of such a country; or
 - A consortium or joint venture where any member of the consortium or joint venture falls under any of the above
- IV. The beneficial owner for the purpose of (iii) above will be as under:
 - In case of a company or Limited Liability Partnership, the beneficial owner is the natural person(s), who, whether acting alone or together, or through one or more juridical person, has a controlling ownership interest or who exercises control through other means.

Clause No. 6: Performance Bank Guarantee/Contract Execution Bank Guarantee

CEBG/PBG may be furnished in the following forms:

- (i) Local cheques of Scheduled Banks (subject to realization)/ Pay Order/Demand Draft/ Electronic Fund Transfer in favour of BHEL.
 - (ii) Bank Guarantee from Scheduled Banks / Public Financial Institutions as defined in the Companies Act. The Bank Guarantee format should have the approval of BHEL.
 - (iii) Fixed Deposit Receipt issued by Scheduled Banks / Public Financial Institutions as defined in the Companies Act (FDR should be in the name of the Contractor, a/c BHEL).
 - (iv) Securities available from Indian Post offices such as National Savings Certificates, Kisan Vikas Patras etc. (held in the name of Contractor furnishing the security and duly endorsed/ hypothecated/ pledged, as applicable, in favour of BHEL).
 - (v) Insurance Surety Bond.
- (Note: BHEL will not be liable or responsible in any manner for the collection of interest or renewal of the documents or in any other matter connected therewith)

Tender Enquiry No. 2890/C/6410/2023/4312/T1 for VERTICAL CNC 5 AXIS MILLING MACHINE-01 No.

Clause No. 7:

The offers of the bidders who are on the banned list and also the offer of the bidders, who engage the services of the banned firm, shall be rejected. The list of banned firms is available on BHEL website <https://hwr.bhel.com>

NOTE: PLEASE VISIT OUR SITE <https://hwr.bhel.com> FOR GENERAL INSRUCTIONS AND STANDARD TERMS AND CONDITIONS (GISTC) FOR TENDER ENQUIRIES. ALL THE BIDDERS/VENDORS MUST ENSURE COMPLIANCE OF THESE GISTC.

**For & on behalf of BHEL, Hardwar.
AGM (Capital Purchase)**

ACCEPTANCE OF COMMERCIAL TERMS BY VENDOR

S. N.	Terms	Description	Your confirmation
1	Confirmation to General Instructions and standard terms & conditions:	<p>Please confirm each clause of following documents: -</p> <ol style="list-style-type: none"> General Instructions and standard terms & conditions for bidding against tender enquiry (GISTC Version May-2024, Rev: 07): Risk Purchase Clause of GISTC is not applicable and has been replaced with Breach of Contract mentioned at SL No. 29 of Annexure-I. Additional terms & conditions of tender enquiry. <p>Deviation to conditions mentioned in above documents, if any, shall be submitted along with offer in separate documents.</p> <p>Please note that in case, no- deviation sheet is received along with the offer, it will be considered that all terms and conditions mentioned in above documents are acceptable to the bidder and your offer will be processed accordingly.</p>	
2	Submission of Offer & Documents Checklist:	<p><u>Superscription on envelopes:</u> The following shall be super scribed on the envelopes: Kindly confirm that the following documents have been submitted along with your offer:</p> <p><u>PART-I</u></p> <ol style="list-style-type: none"> TENDER NO. AND ITEMS DESCRIPTION DUE DATE FOR OPENING. EMD (IF APPLICABLE) OR MSE CERTIFICATE TOWARDS EXEMPTION OF EMD PRE- QUALIFYING REQUIREMENT (PQR) TECHNO-COMMERCIAL BID Un-Price Bid Copy with mentioning only Taxes and Duties (NO PRICE TO BE MENTIONED IN UN-PRICE BID COPY) <p><u>PART-II</u></p> <ol style="list-style-type: none"> TENDER NO. AND ITEMS DESCRIPTION DUE DATE FOR OPENING OF PART-I PRICE BID <p><u>Clause 1.1:</u></p> <p>The Part-I & part-II shall be individually sealed and super scribed as indicated above and shall be enclosed further in the envelop duly sealed and super scribed as:</p> <p>“TENDER FOR (ITEM NAME) AGAINST TENDER NO.----- ----- DUE ON -----CONTAINING PART-I & PART-II OF THIS OFFER.” Vendor’s full name and address should be clearly mentioned on the envelope and shall be addressed to:</p> <p>To,</p> <p>Tender Room, 4th Floor, Main Administrative Building,</p>	

Tender Enquiry No. 2890/C/6410/2023/4312/T1 for VERTICAL CNC 5 AXIS MILLING MACHINE-01 No.

		<p>Heavy Electrical Equipment Plant, BHEL, Ranipur Hardwar- 249403, Uttrakhand.</p> <p>Note: Please note that all details required in supplier registration form to be filled and submitted through online supplier registration portal on https://hwr.bhel.com along with complete documents.</p>	
3	Schedule of Technical Deviation and Schedule of Commercial Deviation.	<p>Schedule of Commercial Deviation and Schedule of Technical Deviation has been annexed along with this tender enquiry. All the Bidders are directed to mention any commercial or Technical deviation in Schedule of Commercial Deviation and Schedule of Technical Deviation only. If any deviation mentioned anywhere other than the Schedule of Commercial Deviation and Schedule of Technical Deviation, then that shall be ignored and It shall be assumed that participating bidder has no deviation against this tender.</p> <p>Please note that as per BHEL's Policy, we cannot allow Price impact for the requirement / scope of supply, which is a part of specifications of our tender enquiry. Hence please read all specification / documents thoroughly and submit your offer as per specifications of tender enquiry.</p>	
4	Validity:	<p>Confirm that your offer shall be valid for 180 days from the date of tender opening.</p> <p>BHEL will reserve the right to reject any or all quotations, quoting validity less than 180 days.</p>	
5	Evaluation criterion:	<p>The evaluation of tender shall be on the basis of “Total Landed cost at Destination” including Supply.</p> <p>Indigenous suppliers: Vendors to quote rates on FOR destination (BHEL Haridwar) basis. However, the insurance will be arranged by BHEL. Vendor can dispatch good through any Indian Bank Association approved transporters having their branch at Haridwar / destination. For the convenience name and address of transporters approved by IBA and BHEL are posted at website www.bhelhwr.co.in. If any bidder still quotes rates on ex-works basis such offers will be loaded by 1.5% of ex-works value towards freight or with actual freight charges as per BHEL freight rate contract whichever is higher.</p> <p>Further, non-availability of BHEL approved transporter will not be accepted for rescheduling of delivery or waiver of penalties.</p>	
6	Insurance:	<p>The Transit Insurance will be arranged by BHEL. Please send your offer keeping this in view.</p>	
7	Technical Requirements	<p>Kindly quote your valuable offer as per Technical Specification of Vertical CNC 5 Axis Milling Machine – 01 No. (enclosed with enquiry).</p> <p>Please ensure that documents submitted with the offer/bid shall be signed and stamped in each page by authorized representative of the bidder.</p>	
8	Payment Terms:	<p>80% payment of Supply value shall be made within 45 days for MSE, 60 days for Medium Enterprises and 90 days for Non-MSE from the date of receipt of material at BHEL. Balance 20% of Supply value plus 100% of E&C portion of PO value will be paid against E&C certificate issued by BHEL and submission of Performance Bank Guarantee (PBG) valid for 27 months from the date of successful commissioning and final acceptance by BHEL, by Supplier from any of the scheduled Banks for 10% of total PO Value in the prescribed Format.</p> <p>Total Erection & commissioning value should be quoted separately by bidders. Only in case where quoted value is less than the value (in %) specified in the NIT or separate commissioning values are not mentioned in the offer, value</p>	

Tender Enquiry No. 2890/C/6410/2023/4312/T1 for VERTICAL CNC 5 AXIS MILLING MACHINE-01 No.

		<p>for commissioning portion shall be deemed to be considered as the value indicated in NIT & accordingly supply value will be adjusted from that quoted value and balance will be released as commissioning payment term mentioned above.</p> <p>Payment of GST will be made after submission of signed and stamped GST certificate, enclosed and submission of Performance Bank Guarantee (PBG) in the prescribed Format. The PBG confirmation charges shall be borne by vendor.</p> <p>Bank Guarantee and Loading against non-acceptance of BHEL's Payment Terms: If payment terms as mentioned by BHEL are not agreed by bidder, such bidder have to submit Bank Guarantee at the time of payment in the prescribed Format of the amount, exceeding 80% of the SUPPLY value, valid till issue of Acceptance Certificate for the equipment. However, in no case, payment against dispatch shall exceed 90% of the SUPPLY Value.</p> <p>Please note that in case of any deviation in the payment terms, BHEL shall evaluate your offer after loading on account of deviation in payment terms as per BHEL practice/policy/" GISTC Rev 07".</p> <p>Loading of any deviation in the payment terms will be done @ Base rate of SBI(as applicable on 31st March of preceding year from tender due date) + 6% (per annum) of basic cost of the items.</p>	
10	PBG terms	<p>Performance Bank Guarantee (PBG) valid for 90 days beyond the guaranty period (for 27 months from the date of successful commissioning of material at BHEL, HEEP Haridwar) by Supplier from any scheduled bank for 10% of total PO Value in the prescribed Format. The PBG confirmation charges shall be borne by vendor. This bank guarantee shall have to be submitted before release of last balance payment.</p> <p>The PBG should be in BHEL's PBG format and should be from one of the scheduled bank of India. The PBG confirmation charges shall be borne by vendor. The Performa of Bank Guarantee and the list of BHEL consortium bank are displayed at BHEL website www.hwr.bhel.com.</p> <p>This should be read and complied in conjunction with Bank Guarantee clause in General Instructions and Standard Term and Conditions for bidding against Tender Enquiry (herein called as GISTC)</p> <p>Please note that, no deviation in submission of Bank Guarantee is acceptable. The offers of the vendors not agreeing to submit PBG is likely to be rejected by BHEL and no further communication in this regard will be entertained.</p>	
11	Contract Execution Bank Guarantee (CEBG):	<p>The successful vendor shall have to furnish a Contract Execution Bank Guarantee (CEBG) for 10% of the Total PO value in the prescribed format within 30 days from the date of P.O. CEBG shall be from one of the scheduled. All bank charges on account of issuance and confirmation of CEBG will have to be borne by the vendor.</p> <p>CEBG shall be kept valid until 30 days after the date of issuance of Final E&C Certificate, which will be issued on completion of Erection & Commissioning of equipment which includes erection,</p>	

Tender Enquiry No. 2890/C/6410/2023/4312/T1 for VERTICAL CNC 5 AXIS MILLING MACHINE-01 No.

		<p>commissioning, job proving, performance tests, training to operators etc. as prescribed in PO.</p> <p>If the supplier fails to submit the CEBG even within 60 days from the date of PO, BHEL reserves the right to cancel PO & forfeit the EMD given by the supplier. In addition, in such case, action will be initiated in line with extant guidelines for Suspension of Business dealings with Suppliers.</p> <p>Under all circumstances, CEBG shall be kept valid till the PBG becomes operational.</p> <p>In case of delay in submission of CEBG, enhanced CEBG which would include interest (SBI rate + 6%) for the delayed period, shall be submitted by the bidder. Further, if CEBG is not submitted till such time the first bill becomes due, the amount of performance security due shall be recovered from the bills along with due interest "</p>	
12	CHARGES FOR SERVICES AT BHEL HARIDWAR	<p>Services to be rendered at BHEL Haridwar like commissioning, proving, training to operators, supervising foundation work etc.</p> <p>These charges are essentially to be indicated separately in price bid. Vendor to confirm BHEL will not provide boarding, lodging, travel cost (Air ticket, local transport etc.) to vendor's representatives visiting BHEL Haridwar for Commissioning.</p> <p>Total commissioning value should be quoted separately by bidders. Only in case where quoted value is less than the value (in %) specified in the NIT or separate commissioning values are not mentioned in the offer, value for commissioning portion shall be deemed to be considered as the value indicated in NIT & accordingly supply value will be adjusted from that quoted value and balance will be released as commissioning payment.</p> <p>The estimated percentage of erection & commissioning value is: <u>5 % of machine cost.</u></p>	
13	TAXES & DUTIES	<p>Details of applicable taxes & duties are to be mentioned as per GISTC Rev. 07.</p> <p>a) GST Registration Number b) Address of Principal place of Business c) Type of Business d) HSN Code, its description & rate of applicable GST for the offered material e) Whether registered under Composite scheme of GST (Y/N).</p> <p>It should be noted that the evaluation of the offers shall be done considering the taxation/benefits as applicable under GST.</p> <p>Please submit your GST registration certificate.</p> <p>Note: TDS as per Statutory guidelines will be deducted at source. Kindly submit your offer accordingly.</p>	
14	GST Rate	<p>1) Rate of GST applicable on Equipment Cost. 2) Rate of GST applicable on E&C Charges</p> <p>GST Input Tax Credit shall be applicable for this tender.</p>	

Tender Enquiry No. 2890/C/6410/2023/4312/T1 for VERTICAL CNC 5 AXIS MILLING MACHINE-01 No.

15	ORDER ACCEPTANCE	Order acceptance (ink-signed) must be submitted within 07 days from the date of PO. If Purchase Order acceptance is not received within 07 days from the date of PO, then it shall be deemed accepted after 07 days from the date of PO.	
16	Submission of Bank Guarantee	All bank guarantees like Contract Execution Bank Guarantee and performance bank guarantee should be in the format as prescribed by BHEL (Annexure-D).	
17	Time Period for Supply and Commissioning of equipment	<p>Activity Schedule has been incorporated in along with this Tender and all the participating bidders are directed to fill the activity schedule with realistic time in weeks for the activities mentioned in activities schedule.</p> <p>Time period to be taken by BHEL has already been mentioned in the activity schedule. Time period of E&C Milestone-1 and Milestone-2 from the date of first intimation given by BHEL Haridwar has been mentioned in activity schedule, but if any vendor wants to quote less time than specified in activity schedule, then vendor can mention that time period in activity schedule else time period mentioned shall be considered by default for this tender. LD shall be governed by the Activity Schedule.</p>	
18	Liquidated Damages Clause	<p>For the purpose of Liquidated Damages for delay E&C of the equipment the duration will be reckoned from the date of intimation by BHEL to vendor for readiness of site.</p> <p>Liquidated Damages on delay in 'Supply' and/or 'E&C' will be applicable to the delays attributed to vendor. Liquidated Damages will be considered separately for 'Supply' and 'E&C'.</p> <p>The rate of Liquidated Damages for delayed Supply shall be @ 0.5% per week of delay of total PO value (Supply + E&C) in supply subject to a maximum of 10% of total PO value (Supply + E&C).</p> <p>The rate of Liquidated Damages for delayed E&C shall be @ 0.5% per week of delay of total PO value (Supply + E&C) in E&C subject to a maximum of 10% of total PO value (Supply + E&C).</p> <p>Maximum Liquidated Damages for delay in Supply and E&C together shall be limited to 15% of total PO value (Supply + E&C).</p> <p>Loading on account of non-acceptance of Liquidated Damages for delayed Supply and/or E&C shall be as under:</p> <p>In case any bidder is not accepting the above Liquidated Damages for delayed Supply and/or E&C, the offer of bidder shall be loaded to the extent to which it is not agreed by the bidder.</p> <p>In case, any shortage is noticed viz-a-viz PO requirement in the main equipment /spares, such shortages shall be replenished by supplier on FOR destination basis without any cost implication to BHEL i.e freight charges etc. up to destination for such short supplies shall be borne by the supplier.</p> <p>Supply period indicated by bidder should include reasonable time required for approval of drawings and other inputs from BHEL. In the Techno-Commercial Bid, the bidder shall submit milestones for various activities in co-relation with Supply and E&C period quoted by him.</p> <p>For calculating Late Delivery Liquidated Damages, delivery date shall be considered as per following:</p> <p>a. Delivery Ex-works: - Date of GR /LR b. Delivery FOR Transporter Godown: - Date of GR/LR</p>	

Tender Enquiry No. 2890/C/6410/2023/4312/T1 for VERTICAL CNC 5 AXIS MILLING MACHINE-01 No.

		c. Delivery FOR Destination: - Date of receipt at BHEL Hardwar (if supply is direct to BHEL) or date of GR + one week (if documents are through bank).	
19	Delivery basis	Delivery must essentially be FOR BHEL Haridwar basis. (Freight charges for indigenous items must essentially be quoted and indicated separately in price bid.) However, loading shall be done as per GISTC Rev 07.	
20	Settlement of Disputes	If any dispute, controversy or claim arising out of, relating to, or in connection with, this contract, or the breach, termination or validity thereof, arises, both parties hereto shall endeavor to settle such dispute amicably. Should this attempt fail, the disputes between the parties shall be resolved through arbitration in accordance with the Arbitration and Conciliation Act, 1996. The attempt to bring about an amicable settlement is considered to have failed as soon as one of the parties hereto, after reasonable attempts (which attempt shall continue for not less than 30 days); give 30 days' notice, in writing, invoking arbitration and calling upon the other party to constitute the tribunal as provided. All or any such disputes or differences arising between the parties to this contract shall be referred to an Arbitral Tribunal consisting of single arbitrators. Sole arbitrator shall be appointed on mutually agreed by both the parties. The language of arbitration shall be English. The substantive law applicable to the substance of the dispute shall be the Indian Law. GISTC clause may be referred for this clause. For Indigenous Source. The venue of arbitration shall be Haridwar Courts, which will have exclusive jurisdiction. Conciliation Clause: Model conciliation clause for conduction conciliation proceedings under the BHEL conciliation scheme, 2018 (enclosed) will be applicable against this enquiry. Arbitration Clause: In case of any dispute arising out of or in connection with this contract, the same shall be referred to arbitration under Arbitration & Conciliation Act 1996 of a sole arbitrator who shall be appointed by mutual consent of the parties. The seat & venue of arbitration shall be Haridwar. The proceedings shall be conducted in English. The governing law of the contract shall be the substantive Law of India.	
21	Drawing / data approval: (If applicable)	Any drawing / data approval, if required, from BHEL after placement of order shall be the responsibility of the vendor and any delay on account of the same shall be the responsibility of the vendor and have no bearing on the penalty applicable.	
22	Drawing / design / information use (if applicable):	The vendor to confirm that the drawing / design / information enclosed with the enquiry / proposed order will not be parted to any other agency and will also not be used for manufacturing for any other customer.	

Tender Enquiry No. 2890/C/6410/2023/4312/T1 for VERTICAL CNC 5 AXIS MILLING MACHINE-01 No.

23	Authorization for pre-inspection (If applicable):	<p>BHEL is authorized to pre-inspect the material at vendor's works as per the enclosed technical specifications. The material will be dispatched only after getting clearance from BHEL.</p> <p>Vendor should give PDI call at least 45 days in advance. If supplier fails to give pre-inspection call with in stipulated time, this will not be a reason of penalty waiver or delivery extension.</p> <p>Travel, Lodging & Boarding charges of BHEL inspectors / trainees during pre-inspection and training will be borne by BHEL.</p>	
24	Attending to any complaint during guarantee period	Vendor will have to ensure deputation of their people for commissioning or for attending to any complaint during guarantee period within 6 days of intimation. In case of delay BHEL will be within their rights to get the job completed at the risk and cost of the supplier.	
25	Contact Details	Details of Contact person Name, Designation, Department complete postal, E-mail address & Fax no, phone, Mobile no. to be mentioned.	
26	Bank Charges	Bank Charges on either side. Or your prices will be loaded suitably.	
27	Participation in Reverse Auction	"BHEL shall be resorting to Reverse Auction (RA) (Guidelines as available on www. https://www.bhel.com/guidelines-reverse-auction-2021) for this tender. RA shall be conducted among the techno- commercially qualified bidders (Guidelines for Reverse Auction – 2021 Doc. No. AA: SSP: RA:05 Dated: 08.03.2021 & subsequent revision dated 02.09.2023). Price bids of all techno-commercially qualified bidders shall be opened and shall be considered for RA as per RA guidelines. In case any bidder(s) do(es) not participate in online Reverse Auction, their sealed envelope price bid along with applicable loading, if any, shall be considered for ranking.	
28	Beneficiary of PO	Please confirm the beneficiary of PO along with the complete address.	
29	Breach of contract, Remedies and Termination	In case of breach of contract, recovery of 10% of total contract value shall be applicable. Recovery shall be done by encashing security instruments like Contract Execution Bank Guarantee, performance bank guarantee. In case value of security instruments available is less than 10% of the contract value, the balance amount be recovered from other financial remedies (i.e. available bills of the contractor, retention amount, etc. with BHEL) or legal remedies shall be pursued. Further, levy of liquidated damages, debarment, termination, de-scoping, short-closure, etc., shall be applied as per provisions of the contract.	
30	Force Majeure Clause	<p>a) Either party shall be entitled to suspend performance of his obligations under the contract to the extent that such performance is impeded or made unreasonably onerous by any of the following circumstances: fire, war, flood, riots, earthquake etc.</p> <p>b. The party claiming to be affected by force majeure shall notify the other party in writing immediately without delay on the intervention and on the cessation of such circumstances. If force majeure prevents the purchaser from fulfilling his obligations, he shall not be forced to compensate the contractor for expenses.</p> <p>c. Regardless of what might otherwise follow from these general conditions, either party shall be entitled to terminate the contract by notice in writing to the other party if performance of the contract remains suspended under Clause Force Majeure for more than 6 months.</p> <p>d. Evidence for this would be "Force Majeure" certificate issued by chamber of commerce of the concerned country.</p>	

Tender Enquiry No. 2890/C/6410/2023/4312/T1 for VERTICAL CNC 5 AXIS MILLING MACHINE-01 No.

31	War Like Situation	If the war like situation has developed in a country where a vendor's works involved in this tender is located or there is political instability and Indian Embassy located in that country forbids dealing with the said vendor or advises for not having any business dealing with vendor located in such zone / region/ country, then BHEL reserves the right not to consider the offer of such a vendor or to cancel the order in case the order has already been placed and suspend further dealings till normalcy in the country/ region is confirmed by Indian Embassy.	
32	Signing of Integrity Pact (IP)	<p>a) IP is a tool to ensure that activities and transactions between the Company and its Bidders/ Contractors are handled in a fair, transparent and corruption free manner. A panel of Independent External Monitors (IEMs) have been appointed to oversee implementation of IP in BHEL. The IP as enclosed with the tender (as Annexure-IV) is to be submitted (duly signed by authorized signatory who signs in the offer) along with techno-commercial bid. Only those bidders who have entered into such an IP with BHEL would be competent to participate in the bidding. In other words, entering into this Pact would be a preliminary qualification.</p> <p>Details of IEM for this tender is furnished below: Name: Following IEMs have been appointed by BHEL for a period of three years:</p> <ol style="list-style-type: none"> 1. Shri Otem Dai, IAS (Retd.) Email Id - iem1@bhel.in 2. Shri Bishwamitra Pandey, IRAS (Retd.) Email Id - iem2@bhel.in 3. Shri Mukesh Mittal, IRS (Retd.) Email Id - iem3@bhel.in <p>(b) Please refer Section-8 of IP for Role and Responsibilities of IEMs. In case of any complaint arising out of the tendering process, the matter may be referred to the IEM mentioned in the tender.</p> <p>Note: <i>No routine correspondence shall be addressed to the IEM (phone/ post/ email) regarding the clarifications, time extensions or any other administrative queries, etc. on the tender issued. All such clarification/ issues shall be addressed directly to the tender issuing (procurement) department. For all clarifications/ issues related to the tender, please contact:</i></p> <p>Name: Ashish Keshari, Manager Deptt: Purchase Capital Address: 4th Floor, Main Administrative Building, BHEL HEEP, Ranipur, Haridwar, Uttrakhand-249403 Phone: +91-1334-281961; +91 9997459201. Email: ashishkumar.keshari@bhel.in Fax:01334 -226462</p> <p>The IP duly signed by authorized official of bidder / contractor / vendor and authorized official of BHEL will form a part of Purchase order / contract.</p>	
33	Details to be furnished by bidder	<ol style="list-style-type: none"> i) Kindly specify the category of your registration under GST like Registered, Unregistered and composite dealer. ii) Kindly furnish your GST registration number, State Code and Name of the State of both the agency who will raise invoice & from where goods will be dispatched. 	

Tender Enquiry No. 2890/C/6410/2023/4312/T1 for VERTICAL CNC 5 AXIS MILLING MACHINE-01 No.

		<p>iii) The bidder shall clearly indicate HSN (<i>Harmonised System Nomenclature</i>) / SAC (<i>Service Accounting Code</i>), and its description.</p> <p>iv) Kindly furnish the rate of GST applicable on your item against subject tender enquiry.</p>	
34	Origin of quotation	<p>a) The quotation should preferably be from the principal bidder. However tender specific authorized registered dealer / agent can also submit the bid on their behalf, failing which the quotation is liable to be ignored. BHEL prefers to deal directly with the principal manufacturers.</p> <p>b) An agent cannot quote on behalf of more than one principal in the same tender enquiry.</p> <p>Please refer clause no. 2 of GISTC Rev. 07 and quote offer accordingly.</p>	
35	Purchase Preference for (Make in India)	<p>For this procurement, the local content to categorize a supplier as a Class-I supplier / class-II local supplier / Non-local supplier and purchase preference to class –I local supplier, is as defined in public procurement (preference to make in India), Order 2017 revision dated 16.09.2020 issued by DPIIT. In case of subsequent orders issued by the nodal ministry, changing the definition of local content for the items of the NIT, the same shall be applicable even if issued after issue of this NIT, but before opening of Part-II bids against this NIT”.</p> <p>The local supplier at the time of tender, bidding or solicitation shall be required to provide self-certification (Format enclosed) that the item offered meets the minimum local content and shall give details of the location (s) at which the local value addition is made.</p>	
36	Training to customer	<p>As per Clause no-15.0 of Technical Specification. Kindly confirm and quote accordingly.</p> <p>Kindly confirm that Lump sum training charges (inclusive of all and irrespective of no. of Man days, visits, Fooding, Boarding, (To & fro) Travelling, accommodations, Lodging, Visa...etc.) have been quoted separately in your offer.</p>	
37	Guarantee Clause:	Kindly confirm that Guarantee shall be offered for a period of 24 months after date of successful commissioning.	
38	Cost of Withdrawal:	<ol style="list-style-type: none"> 1. Cost of withdrawal of deviation will be applicable on the basic price (i.e. excluding taxes, duties & freight) only. 2. All the bidders have to list out all their Technical & Commercial Deviations (if any) in detail in the format for cost of withdrawal only. 3. Any deviation not mentioned in the format for cost of withdrawal and shown separately or found hidden in offer, will not be taken cognizance of. 4. Bidder shall submit duly filled unpriced copy of in the format for cost of withdrawal indicating "quoted" in "cost of withdrawal of deviation" column of the schedule above along with their Techno-commercial offer, wherever applicable. In the absence of same, such deviation(s) shall not be considered and offer shall be considered in total compliance to NIT. 5. Bidder shall furnish price copy of the format for cost of withdrawal along with price bid. 6. The final decision of acceptance/ rejection of the deviations quoted by the bidder shall be at discretion of the Purchaser. 7. Bidders to note that any deviation (technical/commercial) not listed in the format for cost of withdrawal and asked after Part-I opening shall not be considered. 	

Tender Enquiry No. 2890/C/6410/2023/4312/T1 for VERTICAL CNC 5 AXIS MILLING MACHINE-01 No.

		<p>8. For deviations w.r.t. Credit Period, Liquidated damages if a bidder chooses not to give any cost of withdrawal of deviation loading as per GISTC, will apply. For any other deviation mentioned in un-priced copy of this format submitted with Part-I bid but not mentioned in priced copy of this format submitted with Priced bid, the cost of withdrawal of deviation shall be taken as NIL.</p> <p>9. Any deviation mentioned in priced copy of the format for cost of withdrawal, but not mentioned in the un-priced copy, shall not be considered.</p> <p>10. All techno-commercial terms and conditions of NIT shall be deemed to have been accepted by the bidder, other than those listed in unpriced copy of the format for cost of withdrawal.</p> <p>11. Cost of withdrawal is to be given separately for each deviation. In no event bidder should club cost of withdrawal of more than one deviation else cost of withdrawal of such deviations which have been clubbed together shall be considered as NIL.</p> <p>12. In case nature of cost of withdrawal (positive/negative) is not specified it shall be assumed as positive.</p> <p>13. In case of discrepancy in the nature of impact (positive/ negative), positive will be considered for evaluation and negative for ordering.</p>	
39	Submission of offer:	All envelopes to be marked with whether “Priced Bid” (Part – 2) or “Un-Priced Bid Cum Techno-Commercial Bid & PQR” (Part-1). The replica of Priced Bid (without prices) would be necessarily submitted along with Part-1 of the offer.	
40	General Terms:	Please mention separately Packing and Forwarding charges in terms of % of basic prices (if any) and mention specifically that it is inclusive or not in the quoted price. In case the offer is silent regarding these charges, the same would be considered to be inclusive in the offer. Kindly confirm.	
		Please mention separately Freight charges in terms of % of basic prices (if any) and mention specifically that it is inclusive or not in the quoted price. In case the offer is silent regarding these charges, the same would be considered to be inclusive in the offer. Kindly confirm.	
		Confirm that prices will remain firm and fixed during the entire validity and execution of the project.	
41	Delivery Period	Kindly quote the delivery period in no. of weeks from the date of issue of purchase order in Activity Schedule.	
42	Non-Disclosure Agreement	<p>Global Tender enquiry for Vertical CNC 5 Axis Milling machine is being floated through traditional mode i.e hard copy. BHEL Haridwar has internal drawings for this tender enquiry along with Technical Specifications and PQR which shall be required by the participating bidders for better understanding about the requirement of Vertical CNC 5 Axis Milling machine before quoting the tender.</p> <p>BHEL Haridwar has uploaded Technical Specifications, PQR, Photos of Vertical CNC 5 Axis Milling machine, Non-Disclosure Agreement Copy on www.hwr.bhel.com and www.bhel.com . As drawings are highly confidential so considering this, drawings will be shown to bidders during pre-bid meeting at BHEL Haridwar only after furnishing Non-disclosure agreement (NDA) from respective bidders to BHEL.</p>	
43	Action against Bidders/ vendor / supplier/ contractor in	In order to protect the commercial interests of BHEL, BHEL shall take action against supplies / contractors by way of suspension of business dealings, who either fail to perform or are in default without any reasonable cause, cause loss of business/ money/ reputation, indulge in malpractices, cheating, bribery, fraud or any other misconduct or formation of cartels so as to influence the bidding process or influence the price etc.	

Tender Enquiry No. 2890/C/6410/2023/4312/T1 for VERTICAL CNC 5 AXIS MILLING MACHINE-01 No.

	case of default:	Suspension of Business Dealings could be in the form of “Hold” or “Banning” a supplier/ contractor or a bidder and shall be as per “Guidelines for Suspension of Business Dealings with Suppliers/ Contractors” available at BHEL’s website “ https://www.bhel.com/guidelines-suspension-business-dealings-supplierscontractors ”	
44	SPECIAL TERMS -1	Bidder agrees to submit performance security required for execution of the contract within the time period mentioned. In case of delay in submission of performance security, enhanced performance security which would include interest (SBI rate + 6%) for the delayed period, shall be submitted by the bidder. Further, if performance security is not submitted till such time the first bill becomes due, the amount of performance security due shall be recovered as per terms defined in NIT contract, from the bills along with due interest.	
45	SPECIAL TERMS -2	The Bidders has to declares that they will not enter into any illegal or undisclosed agreement or understanding, whether formal or informal with other Bidder(s). This applies in particular to prices, specifications, certifications, subsidiary contracts, submission or non-submission of bids or any other actions to restrict competitiveness or to introduce cartelization in the bidding process. In case, the Bidder is found having indulged in above activities, suitable action shall be taken by BHEL as per extant policies / guidelines.	
46	SPECIAL TERMS -3	<ol style="list-style-type: none"> 1) In the event of any disallowance of input credit or applicability of interest or any other financial liability arises on BHEL-Haridwar due to any default of supplier under GST, such implication shall be to supplier’s account. 2) Statutory Variation in Taxes & duties as applicable at the time of supply shall be payable. However, in the event of no change in law but bidder quoting certain tax structure in bid document which is lower than the applicable one, such amount shall be the maximum amount of tax that can be claimed by bidder. 3) Attach separate sheet for additional information if necessary. The above terms & condition supersedes the terms & conditions found contradictory written elsewhere in the offer. 4) Attach separate sheet for additional information if necessary. The above terms & condition supersedes the terms & conditions found contradictory written elsewhere in the offer. 	
47	SPECIAL TERMS -4	<p>The Bidder declares that they will not enter into any illegal or undisclosed agreement or understanding, whether formal or informal with other Bidder(s). This applies in particular to prices, specifications, certifications, subsidiary contracts, submission or non-submission of bids or any other actions to restrict competitiveness or to introduce cartelization in the bidding process.</p> <p>In case, the Bidder is found having indulged in above activities, suitable action shall be taken by BHEL as per extant policies/ guidelines.</p>	
48	Interest on EMD & Security deposits	It may please be noted that no interest shall be payable upon the earnest money and security deposit on amount payable to the contractor/bidder under the contract.	

Note: This Special Terms and Conditions shall prevail for commercial parameters for this Tender Enquiry.

Signature of supplier with Seal
ANNEXURE-II

PRICE SCHEDULE

VERTICAL CNC 5 AXIS MILLING MACHINE -01 No

Tender Enquiry No. 2890/C/6410/2023/4312/T1 for VERTICAL CNC 5 AXIS MILLING MACHINE-01 No.

Description	Total Price (in Indian rupees)
Total Supply Value (including Essential Tooling's / Consumables, Spares, Training of BHEL Engineers at vendor works as per clause 15 of technical specifications, Packing & Forwarding charges if any) on (F.O.R Haridwar)	
GST on total supply value (mention applicable rate of GST)	
Total supply value at BHEL Haridwar =	
** Total Erection & Commissioning Value including all Services like erection, commissioning, Job proving, performance tests, training to operators etc. at BHEL Haridwar.	
GST on Erection & Commissioning charges (mention applicable rate of GST)	
Total Supply Value (Incl of GST) + E& C Charges (Incl of GST)	

Please attach un-priced copy of your price bid with technical bid. The sequence of price and other details shall be kept same as stated in the specifications.

****Price break-up shall be furnished by bidder as per TECH. SPECIFICATION.**

"ALL BIDDERS ARE REQUESTED TO QUOTE IN FIGURES" WITH CORRESPONDING "WORDS".

FINANCIAL EVALUATION (L1, L2...) WILL BE DONE ON THE BASIS OF TOTAL LANDED COST (SUPPLY + E&C) AT BHEL HARIDWAR.

**Tender Enquiry No. 2890/C/6410/2023/4312/T1 for VERTICAL CNC 5 AXIS MILLING
MACHINE-01 No.**

NOTE:

- a) Item wise breakup of the prices shall be furnished as per TECH. SPECIFICATION / DISCUSSIONS; ELSE, THE BID IS LIABLE FOR REJECTION. Wherever the prices mentioned are unit prices, it should be clearly specified.
- b) Per day per person rates against each category of training at vendor's work must be mentioned separately in Technical Specification.
- c) Bidder to note that total price indicated above shall be considered for evaluation and hence should be complete in all respects for the full scope defined and considering all terms and conditions. Optional as indicated in specification will not be taken for evaluation.
- d) Any item not included in this price quoted above and shown separately will not be taken cognizance of and shall be ignored while evaluation.
- e) Following details shall be provided in separate Annexure.
 - i) Unit prices for variable items.
 - ii) Prices for any other OPTIONAL items.
- f) Transit insurance shall be arranged by BHEL.
- g) The bidder to specify in their offer (part 1 bid) the category of their registration under GST like Registered, Unregistered and composite dealer.
- h) The provisional GST registration number of Bharat Heavy Electrical Ltd, Heavy Electricals Equipment Plant, Ranipur, Haridwar is "05AAACB4146P1ZL" with state Code as "05" and State Name as "Uttarakhand".
- i) Please quote our provisional GST registration number in all invoices raised for supply of goods and services under GST regime and also ensure filing of timely return and payment of tax and compliance of other applicable provisions on supplier under GST regime.
- j) No GST will be reimbursed to unregistered or composite dealer. In the event, any GST is quoted by composite dealer, the same shall be added to the cost of supply in evaluating the bid.
- k) Since, input credit of GST will be available to BHEL-Haridwar only after correct filing of return and payment of applicable GST by supplier, reimbursement of GST shall be made by BHEL-Haridwar on matching of vendor inputs at GST portal, ensuring availability of input credit to BHEL Haridwar. Payment of GST will be made to vendor after matching of input credit and vendor to ensure submission of their invoices along with consent to accept payment of tax after such matching in all cases where bills are submitted directly to BHEL-Haridwar or through bank or under LC or through any other mode.
- l) In the event of any disallowance of input credit or applicability of interest or any other financial liability arises on BHEL-Haridwar due to any default of supplier under GST, such implication shall be to supplier's account.
- m) In the event of any change in the status of the vendor after the submission of the bid but before the supply, GST applicable at the time of supply or in the bid, based on the registration status of the vendor, whichever is lower shall be payable.
- n) Where ever applicable If PAN (Permanent Account Number) of the recipient is not available, income tax is deductible either at the normal rate or at the rate of 20 percent, whichever is higher as per Section 206AA of Indian Income Tax Act 1961.
- o) The bidder shall clearly indicate HSN (*Harmonised System Nomenclature*) / SAC (*Service Accounting Code*), its description and applicable rate of GST for each item in his techno-commercial bid.

**Tender Enquiry No. 2890/C/6410/2023/4312/T1 for VERTICAL CNC 5 AXIS MILLING
MACHINE-01 No.**

- p) Statutory Variation in Taxes & duties as applicable at the time of supply shall be payable. However, in the event of no change in law but bidder quoting certain tax structure in bid document which is lower than the applicable one, such amount shall be the maximum amount of tax that can be claimed by bidder.
- q) IMPORTED GOODS OFFERED BY INDIAN BIDDERS AGAINST DEALER INVOICE: Wherever the material being offered is imported, the bidder must quote the prices inclusive of IGST. The rate and value of IGST as included in the price must be indicated separately. In case quantum of IGST is not mentioned by the bidder the same will not be considered for evaluation. However, bidder will have to pass on the benefit of IGST to BHEL at the time supply.
- r) In case of directly dispatchable items to Customer's Site, BHEL-Haridwar will inform the GST registration number of the respective customer which must be mentioned on the vendor's invoice. Vendor to ensure availability of such information from BHEL-Haridwar before dispatch of any material. However, while filing GSTN-1, BHEL Haridwar GSTN number to be quoted.
- s) Vendors must ensure compliance of all the applicable rules and procedure as envisaged in the GST Regime. Any loss to BHEL-Haridwar due to fault / non-compliance by the vendor will be to the vendor's account.
1. BHEL will evaluate the technical bids against essential criteria/requirements. BHEL may seek clarifications, if required, from the qualified bidders only. These clarifications will be communicated to the eligible vendors and they will be asked to attend techno-commercial discussions on specified dates. The bidders will be given 15 days' notice to come prepared with the required documents/ clarifications. No extension will be given. **The offers of those bidders, who are unable to respond in this time frame, are likely to be ignored.**
 2. The vendors found technically acceptable against their original technical offer and subsequent technical discussion BHEL will communicate equivalent scope of supply to the qualified bidders who will be required to submit their supplementary technical bid along with impact in the form of addition and deletion in their price bid in separate sealed envelope. They will also be required to submit copy of un-priced price bid of these impacts in a 3rd sealed envelope duly super-scribed. These will be submitted within 15 days. The technical bid along with un-priced price bid of impact will be opened on the communicated date and no extension in this time will be given.

It is clarified that no correspondence, technical or commercial, other than the above bids is permissible. In case any uncalled-for correspondence, technical or commercial, is received, the same will be ignored and entire bid also may be ignored. It is also clarified that no commercial discount will be acceptable.

All the bidders whose offers have been accepted by BHEL will be given notice for opening of their original price bid and supplementary impact.

Date :
Signature :
Name :
Designation :
Department :
M/s

DETAILS OF COMPANY PERFORMANCE

A. Capacity Details:

Manufacturing Capacity (Major machines with Qty.)	Type of Major Machines	Qty.
Machines supplied during last 5 years (Year-wise with Qty.)	Scheduled Supply Period	Actual Supply Period
Outstanding Order Book position (Type of Machine with Qty. & name of customers*)		
Liquidation Plan of all machines including BHEL machines under consideration for ordering		

* If any bidder is unable to give name of ALL the customer(s) due to confidentiality restrictions, they may give details without disclosing such customer's identity.

B. Performance of supplies to BHEL:

Details of POs to be considered in last 5 years shall include (i) Last 5 POs fully executed and (ii) all POs overdue for supply and/or E&C. Details of all machines in the POs to be given.

Sl. No.	Name of M/c with broad specs.	Name of BHEL Unit	P.O. No. & Date	P.O. Value	Supply Date		Erection & Commissioning		Reason of delay, if any
					As per P.O.	Actual/ Likely	E&C period incl. job prove out as agreed (in days)	Actual / Likely period of E&C completion (in days)	
(1)	(2)	(3)	(4)	(5)	(6)	(7)	(8)	(9)	(10)
1.									
2.									
3.									
4.									

Note:

1. In case bidder has not received any Purchase Order in the last 5 years from any of the Units of BHEL, then 'NIL' should be indicated.
2. Reasons for delay to be explained in details.
3. BHEL reserves the right to reject the offer, if past performance of the bidder is evaluated to be unsatisfactory and/or false information is given by the bidder.

The performance of the vendors and meeting commitments is of utmost importance. In order to keep this in focus during evaluation / finalization of tenders, Bidder shall be asked to furnish specific details of company performance

1. Capacity details; 2. Performance of supplies to BHEL.
- (A. **Capacity details in Part (A)** are about the Manufacturing Capacity (Major Machine: category-wise & number-wise), No. of Machines supplied during last 5 years, Outstanding Order Book position,

Tender Enquiry No. 2890/C/6410/2023/4312/T1 for VERTICAL CNC 5 AXIS MILLING MACHINE-01 No.

Liquidation Plan of all machines including BHEL machines under consideration for ordering. Wherever possible, efforts are to be made to contact some of the references of past supplies given.

- (B. **The Performance details of supplies to BHEL will be sought in Part (B)** for the POs placed by BHEL which can be verified; hence submission of these information by vendors is mandatory. BHEL will reserve the right to reject the offer, if past performance of the bidder is evaluated to be unsatisfactory and / or false information is given by the bidder.

Immediately after opening of Techno Commercial Bid, the BHEL Haridwar Indenting Unit shall get the past performance details with BHEL verified from concerned Units as a second check.

The tender Technical Committee at BHEL Haridwar Unit shall make use of the information on past performance of the bidders during technical evaluation of the offers.

If Delivery Index of any bidder is >0.20, then his offer shall be liable for rejection. However, offer of bidder with Delivery Index >0.20 can also be accepted for further evaluation on exception basis with justified recorded reasons with approval of Unit Head & provided the bidder fulfils the requirement of proven experience of supplying similar machines & have adequate available capacity to meet BHEL tender requirement.

The actual / likely Supply and E&C period vis-à-vis scheduled Supply and E&C period (delay for reasons attributable to vendor only to be considered) shall be considered for all the machines against the POs placed by BHEL during last 5 years (limited to 5 latest executed POs) and all POs overdue for Supply and/or E&C.

For purpose of calculation of Delivery Index in case of overdue POs, the delay period for Supply and/or E&C will be reckoned from the date of bid opening of the tender under evaluation. In case of two-part bid, part-I (i.e. Techno-Commercial Bid) shall be considered as date of bid opening.

Early Supply and/or E&C vis-à-vis scheduled dates will not be entitled for any consideration for calculation of Delivery Index.

Delay in E&C shall be applicable only in such cases where E&C period has been mentioned in the PO.

In case a PO includes more than one machine, then all the machines of the PO shall be considered for calculation of Delivery Index.

The details of bidder who has been disqualified based on the delivery performance with BHEL Units should be shared by Purchase Department of indenting Unit with all sister Units under intimation to CMT&IP. CMT&IP shall host the details on website of CMT&IP department.

Illustration for calculation of Delivery Index:

$$\text{Delivery Index} = \sum_{i=1}^n \left\{ \frac{(\Delta X_i + \Delta Y_i)}{(X_i + Y_i)} \right\} / n$$

i = No. of Machines; Where, $i = 1, \dots, n$ (n = no. of m/cs.)

X_i = Scheduled Delivery (no. of days)

ΔX_i = Supply delay (no. of days)

Y_i = Scheduled E&C (no. of days)

ΔY_i = E&C delay (no. of days)



BHARAT HEAVY ELECTRICAL LIMITED
HEAVY ELECTRICAL EQUIPMENT PLANT RANIPUR, HARDWAR - 249403,
UTTARANCHAL, INDIA
CONTACT PERSON'S NAME/DESIGN./PHONE NO./E-MAIL (FROM PURCHASE DEPTT.)

Enquiry No.
 Due Date
 Supplier's Qm. No.
 Date

PHONE NO.:
 E-MAIL ID.

TECHNICAL SPECIFICATION FOR 5 AXIS CNC VERTICAL MACHINE - (1 Nos.)

NOTE:-

1. Vendor must submit complete information against clause at Sl.No. 29. The offer, complying this clause, would only be considered.
2. The vendor should fill the "Offered" Column in compliance to specified requirements and also "Deviations" Column, where there is deviation from the requirement. Duly filled specification cum compliance certificate should be submitted along with the offer. Inadequate, incomplete, ambiguous or unsustainable information against any of the clauses of the specifications/requirements shall be treated as non-compliance.
3. The offer and all documents enclosed with offer should be in English language only.

NAME & ADDRESS OF THE SUPPLIER :

TELEPHONE NOS.:

FAX NOS.:

E-MAIL ADDRESS :

SCOPE:	SUPPLY, ERECTION & COMMISSIONING OF 5 AXIS CNC VERTICAL MACHINE (1 Nos.) COMPLYING WITH SPECIFICATIONS AS BELOW :				
Sl. NO.	DESCRIPTION FOR BHEL REQUIREMENT	REQUIRED	OFFERED	DEVIATIONS	REMARKS
1.0	<p>PURPOSE & WORKPIECE MATERIAL</p> <p>Purpose: Vertical CNC Milling Machine having 5 Axis continuous machining capabilities along with special attachments to machine highly accurate and precise details of Large Components having Complex 3 Dimensional Geometries & Aerodynamic profiles such as Impellers, Turbofans, Stationary Blade Rings, Pelton Runner, Francis Runner etc. from monoblock castings.</p> <p>1.1 The machining activities involve 5 Axis synchronous Machining, Facing, Boring, Drilling, Reaming, Threading, Tapping, Reverse Counter Boring, etc. on different work piece materials. Achievable surface quality on finish component should be Ra 0.8 or better in optimized condition.</p> <p>1.2 Work Piece Material: The machine shall be used to machine components composed of Aluminium Alloys, Bronze Alloys, Forged Steel, Carbon Steel, Alloy Steel, Stainless Steel, Cast Iron-etc.</p>	Vendor to note and accept			
		Vendor to note and accept			
		Vendor to note and accept			

Shan Dwarshi *Deep* *AB* *Sek* *Pradyumn*

SI. NO.	DESCRIPTION FOR BHEL REQUIREMENT	REQUIRED	OFFERED	DEVIATIONS	REMARKS
2.00	SPECIFICATION:				
2.1	MACHINE CONFIGURATION The Machine shall be 5 Axis Vertical type CNC Machine (3 or more Linear & 2 or more Rotary Axis) with special attachments having continuous machining capabilities (not indexed) and shall operate in such a manner that 5 or more Axis of machine can machine simultaneously in a synchronous & continuous manner.	Vendor to note and accept			
2.2	MAIN MILLING SPINDLE	Vendor to offer			
2.2.1	No of Milling head : 01	Vendor to confirm			
2.2.2	Spindle Motor Power (AC Drive) : 80 KW (Min.)	Vendor to specify			
2.2.3	Speed Range, Step less: Min: 5 rpm (or less) & Max: 4000 rpm (or more)	Vendor to specify			
2.2.4	Spindle Nose Taper : BT50	Vendor to specify			
2.2.5	Torque at 100% Duty Cycle	Vendor to specify			
2.2.6	Power/Torque-Speed characteristic diagram of the spindle motor to be submitted.	Vendor to submit details			
2.2.7	Oriented Spindle Stop (Any position)	Vendor to confirm			
2.2.8	Max. weight of tool that can be accommodated in the spindle	Vendor to submit details			
2.2.9	30 numbers of Pull-Studs for BT50 taper shall be included along with detailed drawing in the standard scope.	Vendor to confirm & offer			
2.3	CROSS RAIL (W AXIS)	Vendor to offer			
2.3.1	No of Cross Rail : 1 No	Vendor to specify			
2.3.2	No of Columns on which Cross Rail is Mounted : 2	Vendor to specify			
2.3.3	Minimum Distance between Cross Rail Columns : 6000 mm or more	Vendor to specify			
2.3.4	No of Positions of Vertical Traverse of Cross Rail: Positioning after every 200 mm or less or Continuous	Vendor to specify			
2.3.5	Cross Rail Travel: 1000 mm or more	Vendor to specify			
2.3.6	Vertical Traverse Rate	Vendor to specify			
2.3.7	Movement of Cross Rail: Through NC Programs as well as manually by Push buttons (buttons to be provided on Machine control Panel) should be confirmed	Vendor to confirm			
2.3.8	Switch/proximity switch to be provided for feedback of cross rail positioning	Vendor to confirm			
2.4	RAM (Z Axis)	Vendor to Offer			
2.4.1	No of RAM : 1	Vendor to confirm			
2.4.2	Cross Section of RAM	Vendor to specify			
2.4.3	Maximum Distance between Table Top and lowest face of RAM: 3000 mm or more when cross rail is at its highest position & RAM at its Min Extension	Vendor to confirm & submit related sketch			
2.4.4	Vertical traverse of Ram : 1600 mm or more	Vendor to specify			
2.4.5	Rapid Traverse Rate (Z-axis) : 10000 mm/min or more	Vendor to specify			
2.4.6	Feed Rate, Stepless (Z-axis) : 1-5000 mm/min. or more	Vendor to specify			
2.4.7	Axis Resolution : 0.001mm	Vendor to specify			
2.5	LINEAR AXIS I (X/Y)-RAM MOVEMENT ALONG CROSS RAIL)	Vendor to Offer			
2.5.1	Linear Traverse along the Cross Rail : Total Working Traverse 6000 mm or more	Vendor to specify			
2.5.2	Rapid Traverse Rate (Linear axis I) : 10000 mm/min or more	Vendor to specify			
2.5.3	Feed Rate, Stepless (Linear axis I) : 1-5000 mm/min. or more	Vendor to specify			
2.5.4	Axis Resolution : 0.001mm	Vendor to specify			

Shan Kumar

Geek

R

Suk

Worship

Sl. NO.	DESCRIPTION FOR BHEL REQUIREMENT	REQUIRED	OFFERED	DEVIATIONS	REMARKS
2.5.5	Additional Longitudinal Traverse of Linear Axis 1 (X/Y) required to accommodate and use of AAC (if AAC is position at the end of linear axis 1) beyond the specified axis traverse (Sl. No. 2.5.1) shall be separately offered by the vendor.	Vendor to confirm			
2.5.6	The linear axis 1 along the cross rail, may be named as X or Y.	Vendor to specify			
2.6	LINEAR AXIS 2 (YY)-PERPENDICULAR TO CROSS RAIL & Z AXIS)	Vendor to Offer			
2.6.1	Linear Travel Perpendicular to Cross Rail: 8000 mm or more	Vendor to specify			
2.6.2	Rapid Traverse Rate (Linear axis 2) : 6000 mm/min or more	Vendor to specify			
2.6.3	Feed Rate, Steeps (Linear axis 2) : 1-5000 mm/min or more	Vendor to specify			
2.6.4	Axis Resolution : 0.001 mm	Vendor to specify			
2.6.5	Additional Longitudinal Traverse of Linear Axis 1 (X/Y) required to accommodate and use of AAC (if AAC is position at the end of linear axis 2) beyond the specified axis traverse (Sl. No. 2.6.1) shall be separately offered by the vendor.	Vendor to confirm			
2.6.6	The linear axis 2 perpendicular to the cross rail, may be named as X or Y	Vendor to specify			
2.7	MACHINE BED OR ROTARY TABLE				
2.7.1	Vendor to offer configuration either with Fixed Bed Plate or Rotary Table	Vendor to specify and offer			
2.7.1.1	ROTARY TABLE				
2.7.1.1	Table Diameter: 5500 mm or more	Vendor to specify			
2.7.1.2	Load Capacity: 50 T or More	Vendor to specify			
2.7.1.3	Table Speed (Infinitely Variable)	Vendor to confirm			
2.7.1.4	Speed Ranges	Vendor to specify			
2.7.1.5	Bidirectional table positioning and feed during milling	Vendor to confirm			
2.7.1.6	Table rotation (Fully programmable Table-axis): 360000 indexing positions or more	Vendor to confirm			
2.7.1.7	Table Rotary Axis to be one of Milling Axis and same shall be used for machining	Vendor to confirm			
2.7.1.7	Proveout Component as per S.no 20	Vendor to confirm			
2.7.1.8	Power of Main Drive AC	Vendor to specify			
2.7.1.9	Details of Main Drive viz Type, Make, Model etc.	Vendor to specify			
2.7.1.10	Complete Jaw Box Assembly (With Force Multiplier Mechanism) suitable for clamping Cylindrical components : 8 no	Vendor to specify			
2.7.1.11	Serrated slots on Rotary Table for Jaw Boxes : 8	Vendor to confirm			
2.7.1.12	T Slot Track Width : From Outer Periphery of Table to outer periphery of central bore	Vendor to confirm & submit sketch			
2.7.1.13	Minimum External Clamping Diameter : 550 mm	Vendor to confirm			
2.7.1.14	Maximum Internal Clamping Diameter	Vendor to specify			
2.7.1.15	Minimum Internal Clamping Diameter	Vendor to specify			
2.7.1.16	Clamping Force of each Jaw.	Vendor to specify			
2.7.1.17	Positions and Dimensions of the Jaws on Table. Chucking Capacity Diagram should be submitted.	Vendor to confirm			
2.7.1.18	Type of Force Multiplier Mechanism used in Jaws.	Vendor to specify & submit			
2.7.1.19	Type of Bearing for the Table : Hydrostatic (should be confirmed by Vendor)	Vendor to confirm			
2.7.1.20	Table's Hydrostatic Bearing diameter	Vendor to specify			
2.7.1.21	Complete details like bearing diameters, sizes of pockets etc. should be furnished.	Vendor to confirm			
2.7.1.22	Size of T - slots, their position and accuracy. 42 H12	Vendor to specify & submit			
2.7.1.23	Drawing of Table showing details of the T - slots etc. should be submitted.	Vendor to specify			
2.7.1.24	Diameter, Depth and Accuracy of Center Bore on Table Top Surface.	Vendor to specify			
2.7.1.24	Height of machine table top - with ref. to shop floor	Vendor to specify			
2.7.1.25	Rotary encoder, preferably Heidenhain, for Table-Axis	Vendor to confirm			

Askan Durrani

Ref

R

Smt

Deepak

Sl. NO.	DESCRIPTION FOR BHEL REQUIREMENT	REQUIRED	OFFERED	DEVIATIONS	REMARKS
2.7.1.26	Feed drives : Fanne/ Siemens digital AC Servo drives: Details of Make & Model to be submitted. Separate feed drive for each axes.	Vendor to confirm & submit.			
2.7.1.27	Mechanism for locking/ clamping of Table axes	Vendor to specify			
2.7.1.28	4 x 90 deg Precision Positioning (Details to be submitted.)	Vendor to confirm and submit.			
2.7.1.29	Hydrostatic Guideways for Table Linear Traverse (if applicable). Details to be submitted.	Vendor to confirm and submit (if applicable)			
2.7.1.30	Linear Scale with scanning head, preferably Heidenhain, with pressurised compressed air cleaning system for table linear Axis (if applicable)	Vendor to confirm and submit (if applicable)			
2.7.1.31	Backlash free re-circulating ball screw with Pre-loaded double nut for Table Linear axis (if applicable). (Complete description of the same including diameter of Ball Screw, to be submitted with the offer)	Vendor to submit (if applicable)			
2.7.1.32	Metallic Telescopic Covers (if applicable) of rust resistant material are to be supplied with wipers for Table Linear axis. Joints of telescopic covers should be so sealed to avoid mixing of coolant and Hydrostatic oil.	Vendor to confirm (if applicable)			
2.7.1.33	Any platforms for accessing the rotary table shall be within the scope of Vendor	Vendor to confirm (if applicable)			
2.7.2	MACHINE BED PLATE				
2.7.2.1	Table / Bed length : 6000 mm. or more	Vendor to specify			
2.7.2.2	Table / Bed width : 5500 mm. or more	Vendor to specify			
2.7.2.3	Loading capacity of Table/Bed : 10,000 Kg/sq. meter. (minimum) OR MORE	Vendor to specify			
2.7.2.4	Size of T - slots, their position and accuracy. 42 H12	Vendor to specify & submit			
2.7.2.5	Any platforms for accessing the machine bed plate shall be within the scope of Vendor	Vendor to Confirm			
2.7.2.6	Height of machine table top with ref to shop floor	Vendor to specify			
2.8	MACHINE GUIDEWAYS				
2.8.1	Linear Axis 1, Linear Axis 2, & Z Axes traverse shall necessarily be with Hydrostatic Guide ways. Details of system to be submitted with offer	Vendor to confirm & submit related details			
2.8.2	Hardness of Guideways	Vendor to specify			
2.8.3	Metallic Telescopic Covers: The guide ways of all axes should have suitable protective steel telescopic covers with wipers and adequate sealing on joints to prevent seepage of dust & coolant oil inside.	Vendor to confirm & submit details			
2.9	FEED AND DRIVE SYSTEMS				
2.9.1	Linear Axis 1 Feed Drives/Motors (AC Servo Motors) Either Siemens or Fanne Digital	Vendor to Offer			
2.9.2	Linear Axis 2 Feed Drives/Motors (AC Servo Motors) Either Siemens or Fanne Digital	Vendor to specify			
2.9.3	Z Axis Feed Drives/Motors (AC Servo Motors) Either Siemens or Fanne Digital	Vendor to specify			
2.9.4	Feedback Systems for Linear Axis 1, Linear Axis 2 & Z axes: Heidenhain linear scale with pressurised compressed air cleaning	Vendor to specify			
2.9.5	Pre-loaded backlash free Hydrostatic worm OR Pre-loaded backlash free double pinion & rack drive for Linear Axis 1 & Linear Axis 2.	Vendor to confirm & submit details			
2.9.6	Backlash free re-circulating ball screw with Pre-loaded double nut for all other axes(Z & W).	Vendor to confirm & submit details			
2.9.7	Mechanism for Locking of all Linear axes (Linear Axis 1, Linear Axis 2 & Z Axis). Maximum cutting force permissible on RAM (Detail to be provided for further comments)	Vendor to specify			

Ashish Dairvedi

Deepak

Dr.

ent

Shubhendra

Sl. NO.	DESCRIPTION FOR BHEL REQUIREMENT	REQUIRED	OFFERED	DEVIATIONS	REMARKS
2.9.8	Maximum permissible cutting force at Max RAM Extension (Detail to be provided for further comments.)	Vendor to specify			
2.9.9	Permissible Cutting Force v/s Ram Projection (Detail to be provided for further comments.)	Vendor to specify			
2.10	CONSTRUCTION:				
2.10.1	Vendor to furnish details of material, hardness & constructional details, explanatory drawings, photographs including hard copy explaining the technical features of various components/assemblies like Column, Cross Rail, Ram Head, Table, Guideways/slides, Feed Transmission System, Ram, Hydraulic & Lubrication System, Feed back system of the machine etc.	Vendor to submit details			
2.10.2	The machine shall be equipped with compensation system for deflection / deformation in cross-rail due to movement of saddle /headstock with or without various attachments.	Vendor to confirm & submit details			
2.10.3	Ram shall have Hydraulically/Electronically operated balancing system. Its details shall be submitted with the offer with sketches.	Vendor to confirm & submit details			
2.10.4	Video images on CD including hard copy explaining the technical features / Literature with photographs, drawings explaining the technical features should be	Vendor to submit details			
2.11	SPLASH GUARD/CHIP GUARD	Vendor to Offer			
2.11.1	Movable Chip/Splash Guard should be provided all around the Table with sufficient height to avoid spilling of Coolant and scattering of Chips on Operators Platform and Shop Floor	Vendor to confirm			

Shan Dharvedi

Def

Dr

Sanjiv Singh

Sl. NO.	DESCRIPTION FOR BHEL REQUIREMENT	REQUIRED	OFFERED	DEVIATIONS	REMARKS
2.12	OPERATOR'S PLATFORM It should be Independent motorised type, movable/adjustable in Vertical direction.	Vendor to Offer			
2.12.1		Vendor to confirm			
2.12.2	In Vertical Direction it should be able to move to such an extent that maximum height of job that can accommodated on machine	Vendor to confirm			
2.12.3	Interlocks should be provided for its linear movement against Table Rotation(if applicable) to avoid collision/accident.	Vendor to confirm			
2.12.4	Minimum Size of platform: Specify LXWXH. The operator platform should be opened from the side opposite to machine for proper ventilation and desk type structure for keeping Drawings. The cabin should have the doors towards and opposite to machining side	Vendor to specify and confirm			
2.12.5	Height of Platform Railing	Vendor to specify			
2.12.6	Minimum Position of Platform from Shop Floor	Vendor to specify			
2.12.7	Vendor to provide suitable arrangements for accessing Platform from the Shop Floor.	Vendor to confirm			
2.12.8	Weight capacity of Platform (Suitable for at least 3 people)	Vendor to confirm & submit details			
2.12.9	Power Socket of 220V/15 Amp/5 Amp is to be provided on Platform	Vendor to confirm			
2.12.10	One wall mounted fan is to be provided on the operator's Platform at convenient location.	Vendor to confirm			
2.12.11	Operators platform to be equipped with Safety Glass Window for viewing machining area along with safety enclosures. The Glass window should be equipped with vertical up/down motion for clear machining view.	Vendor to confirm			
2.13	AUTO FOCUS HD VIDEO CAMERA	Vendor to Offer			
2.13.1	A detachable/flexible Auto Focus video camera preferably with a magnetic base with zoom facility shall be provided on the RAM, internally connected with colour Monitor fixed on the Operator's panel to view the tool while machining.	Vendor to confirm			
2.13.2	Camera Eyes/lens and connecting cables shall be safe guarded against heat, chips, coolant, dust etc. to maintain clear visibility of tool in any adverse machining conditions	Vendor to confirm			
2.13.3	Suitable sockets and power connections shall be provided (At operator panel as well as in electrical panel)	Vendor to confirm			
2.13.4	Drawings showing mounting and clamping of Camera on the RAM to be submitted with the offer.	Vendor to confirm & submit details			
2.14	OPERATION AND CONTROL SYSTEM	Vendor to Offer			
	OPERATOR'S PANEL: Swivelling type operator's panel having complete CNC and machine control system with display of required configuration shall be provided on the operators platform.				
2.14.1	All switches on the Operator's panel should be within reach of operator of average height (Indian) for convenient, efficient & safe operation. All displays/indications should also be conveniently placed accordingly. Layout showing complete details of the panel should be submitted.	Vendor to submit details			
2.14.2	OPERATOR'S PANEL FEATURES: The Operator Control panel should have the following operational KEYS features on the MCP along with other features as specified by the vendor :				
2.14.2.1	Axes selection keys (Separate for each axis.)	Vendor to confirm			
2.14.2.2	Directional keys + & - for axis movement in jog (Separate for each axis)	Vendor to confirm			

Shantwana

Deep

Sud

Shantwana

Sl. NO.	DESCRIPTION FOR BHEL REQUIREMENT	REQUIRED	OFFERED	DEVIATIONS	REMARKS
2.14.2.3	Rapid traverse key	Vendor to confirm			
2.14.2.4	Emergency stop	Vendor to confirm			
2.14.2.5	Reset Key	Vendor to confirm			
2.14.2.6	Single block switch	Vendor to confirm			
2.14.2.7	Dry run switch (Dry run freely executable during program run in automatic)	Vendor to confirm			
2.14.2.8	Coolant ON / OFF switch/Key with regulator to control the flow (Coolant should be switch on/off during Auto/Log mode irrespective of the definition in the part program).	Vendor to confirm			
2.14.2.9	Pushbutton /key for activating "Delete distance to go"	Vendor to confirm			
2.14.2.10	Chip conveyor forward / reverse push button	Vendor to confirm			
2.14.2.11	Mode selector switch	Vendor to confirm			
2.14.2.12	Feed override switch	Vendor to confirm			
2.14.2.13	Spindle override switch	Vendor to confirm			
2.14.2.14	Machine illumination switch	Vendor to confirm			
2.14.2.15	Push button/Key for Axis Reference	Vendor to confirm			
2.14.2.16	Push button/Key for loading/unloading of tools	Vendor to confirm			
2.14.2.17	Push button/Key for activating tool definition when the tools are loaded manually	Vendor to confirm			
2.14.3	CNC SYSTEM	Vendor to Offer			
2.14.3.1	Make: Siemens or Fanuc, suitable for simultaneous and synchronous 5 Axis Machining(ALL AXIS MACHINING AT SAME TIME)	Vendor to confirm & specify			
2.14.3.2	Type Version : PC based latest version	Vendor to confirm			
2.14.3.3	The CNC system should have full alphanumeric keyboard, TFT colour display 15" or more, network ready with LAN, RS232C port, electronic hand wheels for all axes, USB Port with minimum 1 GB Pen drive for data input/output to/from CNC system in CNC mode, additional qwerty keyboard & optical mouse etc. and preinstalled licensed software & ready to use offered features for CNC system (as mentioned at SI.Nos. from 2.14.3.6 to 2.14.3.38 of tender specifications). In case of non-availability of RS232-C etc. (if not provided by CNC system manufacturer at the time of supply), suitable separate ports for networking with LAN, data input/output, tele diagnostics & USB ports shall be provided. In case, only USB ports (separate port for each function) are provided, suitable hardware/connectors shall be provided to ensure above functionalities. (Linear scale and Scanning head for position feedback). Option for display, editing, loading & backup of PLC program on Operator Panel through USB. Display of NC & PLC Alarms with remedial solution. Power back-up of 30 min for CNC control for Automatic unattended shutdown in the case of power failure or if machine switches OFF. This offered CNC system should be OPC UA compliant with valid license. The system should have feature to store machine related data to BHEL server.	Vendor to offer and confirm			
2.14.3.4	Replaceable SSD Hard disk 10GB, 3GB for User Data or higher as the case may be at the time of ordering	Vendor to confirm & offer.			
2.14.3.5	Standard interfaces	Vendor to confirm			
2.14.3.6	Display of PLC ladder along with online status in realtime on Operator Panel, display of alarm and messages with their remedial action and Display of servo-waveforms on Operator Panel	Vendor to confirm			
2.14.3.7	Access locks on the operator panel	Vendor to confirm			
2.14.3.8	Coordinate System Rotation	Vendor to confirm			
2.14.3.9	Coordinate System Transformation	Vendor to confirm			

Ashtar Shaukat
 Prof
 M
 Suf
 Ishaq

SI. NO.	DESCRIPTION FOR BHEL REQUIREMENT	REQUIRED	OFFERED	DEVIATIONS	REMARKS
2.14.3.10	Look Ahead of atleast 70 blocks	Vendor to confirm			
2.14.3.11	Helical & cylindrical Interpolation	Vendor to confirm			
2.14.3.12	Scaling	Vendor to confirm			
2.14.3.13	Programmable mirror image machining	Vendor to confirm			
2.14.3.14	On screen graphic simulation. (Offline graphic simulation-fast simulation of tool movements without requirement of locking machine axes/independent of machine movements)	Vendor to confirm			
2.14.3.15	5 Axis continuous/simultaneous machining capability with Universal Milling Head	Vendor to confirm			
2.14.3.16	Foreground/Background editing	Vendor to confirm			
2.14.3.17	Process oriented Canned Cycles for Drilling & Milling operation.	Vendor to confirm			
2.14.3.18	Rigid Tapping	Vendor to confirm			
2.14.3.19	Tool Management system	Vendor to confirm			
2.14.3.20	Block search without calculations as well as with calculation in automatic mode	Vendor to confirm			
2.14.3.21	Facility to store at least 20 zero offsets	Vendor to confirm			
2.14.3.22	Absolute/incremental programming	Vendor to confirm			
2.14.3.23	Decimal point programming	Vendor to confirm			
2.14.3.24	Linear & circular interpolation	Vendor to confirm			
2.14.3.25	Programmable dwell	Vendor to confirm			
2.14.3.26	Storage of user defined subroutine independent of the main program	Vendor to confirm			
2.14.3.27	Variable parametric programming with mathematical functions including trigonometric & logic functions	Vendor to confirm			
2.14.3.28	Arc-programming with radius & end-point	Vendor to confirm			
2.14.3.29	Subroutine nesting up to 3 levels	Vendor to confirm			
2.14.3.30	Programmable skip	Vendor to confirm			
2.14.3.31	Facility of inclusion of message in the part program	Vendor to confirm			
2.14.3.32	Corner rounding & chamfering feature	Vendor to confirm			
2.14.3.33	Programming with polar coordinates	Vendor to confirm			
2.14.3.34	Cutter radius compensation	Vendor to confirm			
2.14.3.35	All standard features of CNC System should be listed as well as item wise price of all available optional features of CNC system must also be quoted	Vendor to confirm			
2.14.3.36	Details of Standard features. List to be submitted.	Vendor to submit			
2.14.3.37	Features of CNC System required for identified jobs or foreseen by the vendor as required.	Vendor to submit			
2.14.3.38	Optional features	Vendor to submit			
2.14.4	MANUAL MODE OF OPERATION:				
2.14.4.1	Complete manual control of machine through or independent of CNC system with required switches/keys shall be provided on the operator panel for selection of required axis, axis direction, RPM, cutting feed, RPM Direction i.e. CW / CCW, cutting feed ON/OFF, display of axis position values etc. for manual machining cuts without using CNC program or MDI mode. Diagram / sketch for switches/keys provided on operator's pendant to be submitted.	Vendor to confirm & submit details			
2.15	HAND HELD UNIT :	Vendor to offer			
2.15.1	Vendor to offer Hand held unit with display of CNC system manufacturer along with sufficient length of interfacing cable. The length of the cable should be (minimum 5 meter) sufficient to cover the entire working area of table/bed even when machine control panel is at the end of stroke. The cable should be straight one rather than coiled.	Vendor to offer with details			

Shan Sharda
 Beel
 Smt
 Kishan

Sl. NO.	DESCRIPTION FOR BHEL REQUIREMENT	REQUIRED	OFFERED	DEVIATIONS	REMARKS
2.16	UPS FOR CNC SYSTEM UPS unit including UPS module with rechargeable battery of sufficient time and having provision for unattended automatic shutdown feature for Windows/Linux operating system & Control circuit.	Vendor to offer Vendor to confirm & submit details			
2.17	MACHINE LIGHTS				
2.17.1	Flashing/rotary type end of cutting and program stop light.	Vendor to offer Vendor to confirm			
2.17.2	The control cabinets (Electrical & Operator panel) shall be provided with sufficient illumination and a 220 V/5A & 15A socket to be provided in control cabinets.	Vendor to confirm			
2.17.3	Safety Lights at both ends of moving column (preferably Flashing during Linear Axis-travel)	Vendor to confirm			
2.17.4	Portable Lamp with magnetic base and chord of suitable length. Plug point for its use shall be provided on Head Stock at suitable location.	Vendor to confirm			
2.17.5	Sufficient illumination of working area to be provided. Consumables should be available in India.	Vendor to confirm			
2.17.6	Sufficient lighting with control switch shall be provided in all foundation / pit area. Consumables for the same should be available in India.	Vendor to confirm			
2.18	AIR CONDITIONERS:	Vendor to offer			
2.18.1	Cabinet/ Panel Air Conditioners of suitable/ sufficient capacity with proper drainage pipes and storage for condensate, are to be provided for different control electrical, electronics panels/cabinets including operators panels considering specified outer ambient conditions and inside ambient condition of panel/cabinet. Detailed of specifications of the same are to be submitted. The air conditioners are not to be mounted on top of the panels. Only Eco-friendly refrigerants are to be used in Air Conditioners. (User manual to be provided with each Air Conditioners Unit)	Vendor to offer and submit details			
2.18.2	In case of order, vendor shall confirm to provide following information about air conditioners and chiller units used in the machine : Type of refrigerant, medium to be cooled, capacity of chiller unit, type of compressor with complete specifications, type of thermostatic expansion valve, specification details of condenser fan, specification of the evaporator unit (plate type/ coil type), details of liquid (oil/water) circulatory pump (if any), name of refrigerant used, details of Digital Temperature Controller used in the chiller unit. Only Eco-friendly refrigerants are to be used in chiller units. (User manual to be provided with each Chiller Unit)	Vendor to confirm			
2.19	HYDRAULIC & HYDROSTATIC SYSTEM :	Vendor to offer			
2.19.1	The System should be centralised. HYDROSTATIC & Hydraulic Tank shall preferably be located at floor level	Vendor to confirm			
2.19.2	Make from a reputed manufacturer. (Details to be submitted)	Vendor to submit details			
2.19.3	Filtration System, Details to be submitted.	Vendor to submit details			
2.19.4	Failure indication	Vendor to confirm			
2.19.5	Automatic shut off provision. Details to be submitted.	Vendor to confirm & submit details			
2.19.6	Refrigerated type cooling and electric heating (Electric heating only if required) system of sufficient capacity to maintain complete Hydraulic System, including lubrication oil, hydrostatic oil and gearbox oil, etc. at a temperature not exceeding 40 deg C irrespective of the ambient conditions. Complete details should be submitted	Vendor to confirm & submit details			

Ashish Duvvuri
Dey
Sub
Kupala

Sl. NO.	DESCRIPTION FOR BHEL REQUIREMENT	REQUIRED	OFFERED	DEVIATIONS	REMARKS
2.19.7	Hydraulic & HYDROSTATIC pump capacity (Flow / pressure)	Vendor to submit details			
2.19.8	Each pump should have an independent motor. Tandem pumps should not be used	Vendor to confirm			
2.19.9	First filling of all required Oils, Coolant & Grease etc.: Supplier is to provide first filling of all oils / lubricants / coolant required for the machine from Indian source indicating grade of all oils used. Eco Friendly Coolant to be suitably recommended for the machine.	Vendor to confirm & submit details			
2.19.10	Supplier may recommend three alternative sources for all types of Hydraulic & HYDROSTATIC & lubricating oil.	Vendor to inform			
2.19.11	Hydraulic, Pneumatic & oil piping's should be preferably metallic except places where flexible piping's are essential. All the pipes required for the same shall be included in the standard scope of the machine.	Vendor to confirm			
2.19.12	The offered Hydraulic & Hydrostatic System should ensure 5 Axis Continuous & Synchronous Machining (All 5 Axis Machining together)	Vendor to confirm			
2.20	COOLANT SYSTEM :	Vendor to offer			
2.20.1	Coolant System with all accessories for following variants shall be provided. Selection of all the variants shall be through program and push buttons provided on the Operator's panel as well.	Vendor to confirm			
2.20.2	Recirculating Type Flood Coolant System with nozzles around spindle.	Vendor to confirm			
2.20.3	Air coolant system	Vendor to confirm			
2.20.4	High Pressure Coolant through Spindle	Vendor to confirm			
2.20.5	All attachments, tool holders, boring bars, cassettes, adapters etc. shall have the provision so that coolant is available directly at the tool-cutting tip.	Vendor to confirm			
2.20.6	Coolant collection and recirculation system should be leak-proof & perfect to avoid any spillage on shop floor, trenches for cables & foundation pit of the machine etc.	Vendor to confirm			
2.20.7	Coolant Filtration System: Recirculating type coolant system with centrifugal Hydrocyclone System/ Vacuum Rotary drum type System/ Cartridge Type Filtration System and magnetic separator.	Vendor to inform & submit details			
2.20.8	Coolant Flow Diagram showing filters, pumps, valves, tanks etc. to be submitted with the offer.	Vendor to submit details			
2.20.9	Pressure & rate of flow of coolant for different variants should be furnished in the offer. The Pressure should be sufficient for the coolant to reach the tool tip at full pressure.	Vendor to confirm & submit details			
2.20.10	The coolant tank capacity shall also be intimated. Coolant tank capacity, discharge rate & pressure of coolant should be sufficient enough to meet the machining requirement.	Vendor to confirm & submit details			
2.20.11	In addition to M codes and push buttons provided on the operator's panel for activation & deactivation of coolant supply, additional rotary switch shall also be provided on the operator's panel for finer control of coolant flow rate and its pressure after its activation through M codes/ Push button.	Vendor to confirm			
2.20.12	Coolant pump & motor details for all variants of coolant system are to be submitted with the offer.	Vendor to submit details			
2.20.13	The coolant tank should be fitted with skimmer for regular cleaning of coolant from contamination with tramp oil.	Vendor to confirm			
2.20.14	If any PLC system is used for the operation of coolant system, the same should be included in spare and licensed software and cables to be provided to connect with the PLC through portable programming device/laptop.	Vendor to confirm			
2.20.15	Vendor to offer one spare coolant gun	Vendor to confirm & offer			

Shan Shrivastava
 [Signature]
 [Signature]
 [Signature]
 [Signature]

SL. NO.	DESCRIPTION FOR BHEL REQUIREMENT	REQUIRED	OFFERED	DEVIATIONS	REMARKS
2.21	ELECTRICAL SYSTEM : 415V + 10% / -10%, 50HZ +/-3 %, 3 Phase AC (3 wire system without neutral) Power Supply Source will be provided by BHEL at a single point near the machine, as per layout recommended by Vendor. All types of cables, connections, circuit breakers etc. required for connecting BHEL's power supply point to different parts of the machine/control cabinets, shall be the responsibility of vendor. Requirement of grounding/earthing with required material details is to be informed by vendor well in advance so that same could be incorporated during construction of foundation.	Vendor to offer			
2.21.1		Vendor to note & confirm			
2.21.2	Tropicalisation: All machine electrical, controls, instrumentation and paints shall be suitably tropicalized.	Vendor to confirm			
2.21.3	All electrical & electronic control cabinets & panels should be dust and vermin proof	Vendor to confirm			
2.21.4	All electrical components in the cabinets should be mounted on DIN Rail	Vendor to confirm			
2.21.5	All electrical and electronic panels including operator's panel should be provided with fluorescent lamps for sufficient illumination and power receptacles of 220Volts, 5/15 Amp AC. All adapters/receptacles should have compatibility with Indian equivalents.	Vendor to confirm			
2.21.6	Motors shall conform to IEC or Indian Standards	Vendor to confirm			
2.21.7	All cables moving with traversing axes should be installed in Caterpillar/ Drag chain. Additionally, all the cable trays required for laying of cables should be included in the offer.	Vendor to confirm			
2.21.8	Vendor should ensure the proper earthing for the machine and its peripherals. Any material required for the same shall also be supplied. The vendor can take earthing connection from the nearest column of the production shop.	Vendor to confirm			
2.21.9	The offered Electrical System should ensure 5 Axis Continuous & Synchronous Machining (All 5 Axis Machining together)	Vendor to confirm			
2.21.10	Vendor to inform rated power consumption of the machine	Vendor to specify			
2.21.11	An Electric meter displaying the power consumption of the machine with memory capacity to be provided along with the machine.	Vendor to offer			
	SAFETY ARRANGEMENTS:				
2.22	Following safety features in addition to other standard safety features should be provided on the machine: Machine should have adequate and reliable safety interlocks / devices to avoid damage to the machine, workpiece and the operator due to the malfunctioning or mistakes. Machine functions should be continuously monitored and alarm / warning indications through lights/ alarm number with messages (on CNC display and panels) should be available.	Vendor to confirm & offer			
2.22.1		Vendor to confirm			
2.22.2	A detailed list of all alarms, messages, indications long with remedial solution to be provided on machine should be submitted by the supplier.	Vendor to confirm			
2.22.3	All the pipes, cables etc. on the machine should be well supported and protected.	Vendor to confirm			
2.22.4	All the rotating parts used on machine should be statically & dynamically balanced to avoid undue vibrations.	Vendor to confirm			
2.22.5	Emergency Switches at suitable locations as per International Norms are to be provided.	Vendor to confirm			
2.22.6	Oil & water pipe lines should not run with electrical cable in the same tray / trench	Vendor to confirm			
2.22.7	Safety Lights at both ends of moving column (preferably Flashing during X-travel).	Vendor to confirm			
2.23	ENVIRONMENTAL PERFORMANCE OF THE MACHINE : The Machine shall conform to following factors related to environment :				

Asman Dasgupta

Prof

R

Suf

Impyals

Sl. NO.	DESCRIPTION FOR BHEL REQUIREMENT	REQUIRED	OFFERED	DEVIATIONS	REMARKS
2.23.1	Maximum noise level shall be 85 dB(A) at normal load condition, 1 M away from the machine with correction factor for back ground noise, if necessary. This will be measured as per international standards like DIN 45635-16. Supplier to demonstrate compliance to noise level, if so required.	Vendor to confirm			
2.23.2	There shall not be any emissions from the machine except fumes of cutting fluid during machining.	Vendor to confirm			
2.23.3	There should not be any effluent from the machine. In case there are any effluents from the machine, requisite effluent treatment plant or pollution control device should be built into the machine by the supplier.	Vendor to confirm			
2.23.4	No hazardous chemicals shall be required to be used in the machine.	Vendor to confirm			
2.23.5	Safety / environmental protection enclosure as required should be built in/round the machine by the vendor.	Vendor to confirm & offer			
2.23.6	Paint of the machine should be oil / coolant resistant and should not peel off and mix up with coolant.	Vendor to confirm			
2.24	The machine will have manual tool loading/ unloading with push buttons mounted on headstock / Auxiliary Hand pendant/MCP	Vendor to confirm			
3	AUTOMATIC CHIP CONVEYOR:				
3.1	No of swarf / chip conveyors : 2 (one on each side of work table along Linear Axis Perpendicular to Cross rail)	Vendor to Offer			
3.2	Type of chip conveyor	Vendor to confirm			
3.3	Width of conveyor	Vendor to specify			
3.4	Elevation of chip conveyor for chip bin	Vendor to specify			
3.5	Material of chip conveyor (to be rust resistant)	Vendor to specify			
3.6	Operation of chip conveyor (forward & reverse) through push buttons on operator's panel and at Chip Conveyor	Vendor to specify			
3.7	Layout showing location of chip conveyor to be submitted	Vendor to confirm			
3.8	The chips shall be brought by chip chutes manually as well as by gravity into the coolant channels, which are provided on both sides along the machine table. Chip chutes shall be provided by the vendor. Detailed drawings of the same shall also be provided by the vendor. With the help chip conveyor the chips are to be transported to a suitable container located at one end of the machine. The container shall be included in the standard scope.	Vendor to submit details			
		Vendor to confirm & submit details			







SI. NO.	DESCRIPTION FOR BHEL REQUIREMENT	REQUIRED	OFFERED	DEVIATIONS	REMARKS
4	SERVO VOLTAGE STABILIZER: Power Supply will be provided by BHEL at a single point near the machine, as per layout recommended by Vendor. All types of cables, connections, circuit breakers etc. required for connecting BHEL's power supply point to different parts of the machine, Voltage Stabilizer, Isolation Transformer, control cabinets etc. shall be supplied by the vendor. A suitable servo-controlled-voltage stabilizer of Indian Make and of appropriate rating shall be supplied and connected to the machine by the vendor. The Oil / Air Cooled Servo Controlled Voltage Stabilizer (of reputed Indian make) should be suitable for the complete machine, its drives, controls, PLC etc. for unbalanced load & supply conditions considering specified power supply & ambient conditions. Catalogue of the same shall be submitted along with the offer.	Vendor to Offer Vendor to confirm along with make model and technical details			
4.1					
4.2	The offer should be submitted with spares package (Variaes-2 nos, Correcting servomotors-2 nos., Control cards-2 nos, Main switch-1 no, push buttons-5 nos, each type) required for long term maintenance of this stabilizer. If any PLC system is used against sr. no. 4.1, the same should be included in spare and licensed software and cables to be provided to connect with the PLC through portable programming device/laptop.	Vendor to offer			
4.3	Make : NEEEL, Aplab or Auto Electric or equivalent	Vendor to specify			
4.4	Rating & Input/output Voltage etc.	Vendor to specify			
4.5	Monitoring device with cut-off facility for under/over output voltage, Devices for load current measurement, MCCB at input for overload/short circuit protection. (Details to be submitted)	Vendor to specify with technical details.			
4.6	Catalogue of the SERVO VOLTAGE STABILIZER shall be submitted with the offer.	Vendor to submit			
5	ULTRA ISOLATION TRANSFORMER	Vendor to offer			
5.1	Indian make Ultra Isolation Transformer suitable for complete machine, its drives, controls, PLC etc. shall be supplied for unbalanced load & supply conditions considering specified power supply & ambient conditions.	Vendor to offer			
5.2	Make : NEEEL, Aplab or Auto Electric or equivalent	Vendor to specify			
5.3	Rating	Vendor to specify			
5.4	Spares Package for the Ultra Isolation Transformer for 2 years working should also be offered.	Vendor to offer			
5.5	Catalogue of the Ultra Isolation Transformer shall be submitted with the offer.	Vendor to submit			
6	PNEUMATIC SYSTEM:				
6.1	AIR COMPRESSOR: Independent Screw Air Compressor (of reputed make Elgi, Chicago Pneumatic or Ingersol Rand) with refrigerated type Dryer & Filter of suitable capacity for the total compressed air requirements of the machine & accessories and to suit required air quality should be supplied. The system should be so designed to have additional provision and required accessories before Refrigerated type Air Dryer so that BHEL compressed air supply having pressure 13-15 Kg/sq.cm with high moisture could be used as and when required. The compressor unit should be suitable for continuous duty operation.	Vendor to offer			
6.1.1		Vendor to offer with details.			
6.1.2	Make & Model of Air Compressor and Refrigerator type Dryer.	Vendor to specify			
6.1.3	Capacity (Flow, Pressure & KW)	Vendor to specify			

Ashwani Dandekar *Deep* *Dr. Suf* *Prakash*

SL. NO.	DESCRIPTION FOR BHEL REQUIREMENT	REQUIRED	OFFERED	DEVIATIONS	REMARKS
6.1.4	Spares Package for the compressor for 2 years trouble free working should also be offered. List to be submitted.	Vendor to offer and submit			
6.1.5	The spares package must include all type of filters and separators(5 no. each type), Temperature probe, Belt, air intake valve, RTD, Thermal valve and Oil (30 litres).	Vendor to offer and submit			
6.1.6	If supplied air compressor is equipped with any PLC device, the same should be included in spare and licensed software and cables to be provided to connect with the PLC through portable programming device/laptop.	Vendor to specify			
6.2	COMPRESSED AIR POINTS:				
6.2.1	Compressed Air Point with manual ON/ OFF Valve and flexible pipe of suitable length for work piece cleaning.	Vendor to confirm			
6.2.2	Programmable Compressed air point in the head stock to be used as coolant for carbide tools.	Vendor to confirm			
6.2.3	Vendor to offer one spare air gun	Vendor to confirm			
7	DIAGNOSTIC SYSTEMS:				
7.1	REMOTE TELE DIAGNOSTIC SERVICE:	Vendor to offer			
7.1.1	Tele-diagnostic service should be provided through Ethernet along with required Hardware / Software package for the supplied CNC system for remote diagnosis and correction of the problems in both CNC System and PLC of the machine. This should be provided free of charge for the guarantee period. Terms and conditions for the service after guarantee period should be informed by vendor. Help guide should be provided for use of the system/service. Subsequently, it should be possible to use other platforms, such as Internet or ISDN, subject to their availability in future. The port should be made available in the electrical panel.	Vendor to confirm & submit details			
7.2	FAULT DIAGNOSTIC SYSTEM:	Vendor to offer			
7.2.1	Supplier's own diagnostic system with required Software and Hardware installed on the CNC system, which shows detailed cause and remedy for the fault on the CNC system display with diagnostics (including images/Electrical circuit drawing) indicating the element/device name causing the fault.	Vendor to offer & submit			
7.2.2	Vendor to offer a programming device/laptop having at least core i7 (13 generation or above), FHD, 16GB RAM (DDR5), 512 GB SSD, 15" display, Windows 11 pro 64 bit licensed. The supplied programming device/laptop should be loaded with all the licensed software required to connect with any supplied PLC, HMI, Servo drives and CNC for diagnostic, commissioning and maintenance purpose. All necessary cables, PC/MCIA card / Adaptor required to be included in offer. The supplied programming device/laptop should be loaded with complete Electrical Schemes, Mechanical Assembly drawings, Hydraulic Circuit Diagrams, Operation and Maintenance Manuals, Special procedures required for restoration and operation of AAC/ATC/Attachments, Machine Alarm list along with Help text wiring diagram, On-Line display of PLC user should be available on the note book PC.	Vendor to offer & submit			
7.2.3	Provision of OEM Screen with soft keys enabling the service personnel to bring back the tool carriers of the AAC to its initial/nearest position in case of interruption of tool carrier's positioning cycle due to alarm on the machine or power failure. With this OEM screen, service personnel should be able to perform individual steps of Tool carriers positioning cycle manually. Separate Hand Held Pendant should also be provided to retrieve the tool carrier to it's initial position.	Vendor to offer			

Ashwini

Deep

D. Suf

Prakash

SI. NO.	DESCRIPTION FOR BHEL REQUIREMENT	REQUIRED	OFFERED	DEVIATIONS	REMARKS
7.2.4	Machine should have provision to switchover from position feedback system -2 (direct) to Position feed back system-1 (Motor encoder) through password protected customised screen on operator panel as well as through PLC program (for service personnel only).	Vendor to offer			
7.2.5	Provision to correct the misaligned gantry for the service personnel to be provided. Detailed documents to be provided for this purpose.	Vendor to provide detail			
7.2.6	Vendor shall provide all tool and tackles required for CNC maintenance like Clamp meter, Multimeter, Socket Set etc.	Vendor to offer			
7.2.7	Help guide should be provided to use above two diagnostic systems shall be provided.	Vendor to confirm			
8	LEVELLING & ANCHORING SYSTEM:	Vendor to offer			
8.1	Complete anchoring system including foundation bolts, anchoring materials, fixators, levelling shoes etc. shall be supplied for the Machine, Table/bed etc.	Vendor to confirm			
9	TOOLS FOR ERECTION, OPERATION & MAINTENANCE.:	Vendor to offer			
9.1	Special tools and equipment required for erection of the machine shall be brought by the vendor. Necessary tools like Torque Wrench, Spanners, Keys, grease guns, and any other special purpose tool etc for operation and maintenance of the machine should be supplied. List of such tools should be submitted with offer.	Vendor to confirm & submit details			
9.2	Special Tools/fixtures required to check & align the accuracy of machine shall be supplied.	Vendor to confirm & offer			
9.3	Test mandrel for checking spindle run-out & alignment shall be supplied	Vendor to confirm & offer			
10	MANUAL LOADING & UNLOADING OF TOOLS :				
10.1	The machine will have manual tool loading/ unloading with push buttons mounted on Auxiliary Hand pendant as well as Attachments Heads mentioned at S.no 11.2 to 11.5	Vendor to confirm			
11	ACCESSORIES AND ATTACHMENTS:				
11.1	AUTO ATTACHMENT CHANGER SYSTEM(AAC):	Vendor to offer			
11.1.1	Loading & unloading of all offered attachments should be possible through Auto Attachment Changer system (Pick-Up station). The same to be offered along with attachment rack of suitable capacity. The placing of pick-up station with requisite interlocks should be such that machining of job on the Table/bed is not disturbed.	Vendor to confirm & submit details			
11.1.2	All attachments shall be suitable for loading / unloading through AAC	Vendor to confirm			
11.1.3	No. of storage positions : No. of attachments + 1. Vendor to provide separate cradle/ stand suitable to unload the attachment for service purpose.	Vendor to confirm			
11.1.4	Location of the attachment changer along with sketch	Vendor to specify and submit sketch			
11.1.5	Mounting plates as required for attachments should be supplied	Vendor to confirm			
11.1.6	Maximum Permissible Weight on Complete AAC.	Vendor to specify			
11.1.7	Suitable Software based and manual key based arrangement should be provided to extract an Attachment trapped in the AAC cycle. Details of both the system to be provided along with the offer.	Vendor to offer and submit			
11.2	MILLING HEAD WITH CONTINUOUS SWIVELLING AXIS FOR MACHINING 3D SURFACES	Vendor to offer			
11.2.1	Sample sketch of head attached in Annexure 1(Attachment 1)	Vendor to Note			

Shant Duvet

Prof

W

Suf

Kupfer

SI. NO.	DESCRIPTION FOR BHEL REQUIREMENT	REQUIRED	OFFERED	DEVIATIONS	REMARKS
11.2.2	Geometry and Physical Dimensions of the Milling Head should be designed in such a manner that this head, along with other attachments mentioned at S.no 11.3 to 11.6 are able to machine entire surfaces including airfoil, fillets, conical bore, slots & Drills of the proveout component as per S.no 20.	Vendor to confirm			
11.2.3	Swivelling Axis to be continuous and not indexable	Vendor to confirm			
11.2.4	No of Continuous Swivelling Axis : 1 or more	Vendor to specify			
11.2.5	A/B - axis Range : +/- 95 Deg. (Minimum) from Vertical Axis	Vendor to specify			
11.2.6	Resolution of Swivelling Axis : 0.001 Deg	Vendor to confirm			
11.2.7	Transmittable Power : 50 KW or more	Vendor to specify			
11.2.8	Max Torque	Vendor to confirm			
11.2.9	Speed Ratio: 1:1 Between Main spindle and Head	Vendor to confirm			
11.2.10	Speed Range (RPM-Infinately Variable)	Vendor to specify			
11.2.11	Spindle taper : BT 50	Vendor to confirm			
11.2.12	Weight of the head	Vendor to specify			
11.2.13	Max Weight of the tool that can be accommodated in Head	Vendor to confirm			
11.2.14	External as well as Internal (through spindle) Coolant System with requisite flexible pipes on its snout is to be provided. Its details shall be submitted with the offer.	Vendor to confirm & submit details			
11.2.15	The Milling Head should have a push button to enable manual loading and unloading of tools	Vendor to confirm			
11.2.16	Power/Torque-Speed characteristic diagram of the Milling head to be submitted with the offer.	Vendor to submit details			
11.2.17	Make & Model of Head including drawing/sketch/catalogue pages showing major dimensions of the Head to be submitted with the offer.	Vendor to submit details			
11.2.18	Pull Stud (4 Sets) for mounting the Head on RAM shall be supplied along with detailed drawing.	Vendor to confirm & submit details			
11.2.19	Customised cycle to be provided for programmable positioning/indexing of the Milling Head for drilling/milling at compound angle and the same to be demonstrated during proveout of component/test piece.	Vendor to confirm & submit details			
11.2.20	The offered milling head should be fully programmable & customized to carryout machining (Facing, drilling, Boring, Circular interpolation with cutter compensation, Tapping, thread milling etc.) at different angular positions with reference to existing work offset.	Vendor to confirm			
11.3	SPECIAL MILLING HEAD WITH CONTINUOUS SWIVELLING AXIS FOR MACHINING NARROW GAPS ON 3D SURFACES	Vendor to offer			
11.3.1	Sample sketch of head attached in Annexure I(Attachment 1)	Vendor to Note			
11.3.2	The purpose of this Milling Head is to machine Narrow Zones between the Blades and Intersection of Blades with Hub	Vendor to Note			
11.3.3	Geometry and Physical Dimensions of the Milling Head should be designed in such a manner that this head, along with other attachments mentioned at S.no 11.2,11.4 to 11.6 are able to machine entire surfaces including airfoil, fillets, conical bore, slots & Drills of the proveout component as per S.no 20.	Vendor to confirm			
11.3.4	Swivelling Axis to be continuous and not indexable	Vendor to confirm			
11.3.5	No of Continuous Swivelling Axis : 1 or more	Vendor to specify			
11.3.6	A/B - axis Range : +/- 95 Deg. (Minimum) from Vertical Axis	Vendor to specify			
11.3.7	C - axis Range (if applicable) : 0-360 Deg. (Minimum) from Vertical Axis	Vendor to specify			
11.3.8	Resolution of Swivelling Axis for A/B Axis : 0.001 Deg	Vendor to confirm			
11.3.9	Resolution of Swivelling Axis for C Axis (If Applicable)	Vendor to specify			
11.3.10	Transmittable Power : 25 KW or more	Vendor to specify			

Ashwanth

Ques

or

ent

Inspected

Sl. NO.	DESCRIPTION FOR BHEL REQUIREMENT	REQUIRED	OFFERED	DEVIATIONS	REMARKS
11.3.11	Max Torque	Vendor to specify			
11.3.12	Speed Ratio:	Vendor to specify			
11.3.13	Speed Range (RPM-Infinity Variable)	Vendor to specify			
11.3.14	Spindle taper : BT 50	Vendor to confirm			
11.3.15	Weight of the head	Vendor to specify			
11.3.16	Max Weight of the tool that can be accommodated in Head	Vendor to specify			
11.3.17	External as well as Internal (through spindle) Coolant System with requisite flexible pipes on its snout is to be provided. Its details shall be submitted with the offer.	Vendor to confirm & submit details			
11.3.18	The Milling Head should have a push button to enable manual loading and unloading of tools	Vendor to confirm			
11.3.19	Power/Torque-Speed characteristic diagram of the Milling head to be submitted with the offer.	Vendor to submit details			
11.3.20	Make & Model of Head including drawing/sketch/catalogue pages showing major dimensions of the Head to be submitted with the offer.	Vendor to submit details			
11.3.21	Pull Stud (4 Sets) for mounting the Head on RAM shall be supplied along with detailed drawing.	Vendor to confirm & submit details			
11.3.22	Customised cycle to be provided for programmable positioning/indexing of the Milling Head for drilling/milling at compound angle and the same to be demonstrated during proveout of component/test piece.	Vendor to confirm & submit details			
11.3.23	The offered milling head should be fully programmable & customized to carryout machining (Facing, drilling, Boring, Circular interpolation with cutter compensation, Tapping, thread milling etc.) at different angular positions with reference to existing work offset.	Vendor to confirm			
11.4	LONG VERTICAL HEAD	Vendor to offer			
11.4.1	Sample sketch of Long Vertical Head attached in Annexure 1	Vendor to Note			
11.4.2	Long Vertical Head to be directly mountable on RAM	Vendor to confirm			
11.4.3	Length of Long Vertical Head from Ram Face to Tip of Spindle : Min 800 mm	Vendor to specify			
11.4.4	Diameter of Long Vertical Head	Vendor to specify			
11.4.5	Power of Long Vertical Head : Not less than 90% of Main Milling Spindle	Vendor to specify			
11.4.6	Spindle Taper : BT50	Vendor to confirm			
11.4.7	Speed Ratio: Between Main spindle and Long Vertical Head	Vendor to specify			
11.4.8	Speed Range	Vendor to specify			
11.4.9	Torque at 100% Duty Cycle	Vendor to specify			
11.4.10	Oriented Spindle Stop (Any position)	Vendor to confirm			
11.4.11	Max. weight of tool that can be accommodated in the Long Vertical Head	Vendor to submit details			
11.4.12	Weight of the Long Vertical Head	Vendor to specify			
11.4.13	Max Weight of the tool that can be accommodated in Long Vertical Head	Vendor to specify			
11.4.14	External as well as Internal (through spindle) Coolant System with requisite flexible pipes on its snout is to be provided. Its details shall be submitted with the offer.	Vendor to confirm & submit details			
11.4.15	Make & Model of Long Vertical Head including drawing/sketch/catalogue pages showing major dimensions of the Head to be submitted with the offer.	Vendor to submit details			
11.4.16	Pull Stud (4 Sets) for mounting the Long Vertical Head on RAM shall be supplied along with detailed drawing.	Vendor to confirm & submit details			
11.5 SPECIAL BORING AND FACING HEAD (Body Dia. 360mm)					
11.5.1	Sample sketch of Special Boring & Facing Head is attached in Annexure 1	Vendor to offer			
11.5.2	Special Boring & Facing Head to be directly mountable on RAM	Vendor to Note			
11.5.3	Head body diameter : 360 mm	Vendor to Confirm			

Shankar

Qref

Dr

Spr

Junjola

SI. NO.	DESCRIPTION FOR BHEL REQUIREMENT	REQUIRED	OFFERED	DEVIATIONS	REMARKS
11.5.4	Tool slide stroke : 120 mm or more	Vendor to specify			
11.5.5	Facial and Radial Run outs	Vendor to specify			
11.5.6	Max RPM: 500 or more	Vendor to specify			
11.5.7	Boring Accuracy: H7	Vendor to specify			
11.5.8	Surface Finish: 0.8 Microns Ra or better	Vendor to specify			
11.5.9	Min. Boring Dia : 400 mm or less	Vendor to Confirm			
11.5.10	Max. Boring dia : 670 mm or more	Vendor to Confirm			
11.5.11	Max. Boring depth (With Tool) : 1300 mm or more	Vendor to Confirm			
11.5.12	Min. Facing Dia :	Vendor to specify			
11.5.13	Max. Facing dia :	Vendor to specify			
11.5.14	Slide feed rate	Vendor to specify			
11.5.15	Maximum torque	Vendor to specify			
11.5.16	Maximum cutting force in boring:	Vendor to specify			
11.5.17	Slide Counter Balance mechanism details	Vendor to specify			
11.5.18	Complete set of standard Tool Holders and Tools, to be used with the offered Head. Any special arrangement offered to meet the specified requirement of Conical Bore of component as mentioned in Annexure 2. Top mounting extension/tool heads like MR/TU/ in sufficient numbers with at least one adaptor for every Boring Tool/ Cartridge used in the prove out components	Vendor to confirm and submit details			
11.5.19	Catalogue of the offered Head.	Vendor to Offer			
11.5.20	Coolant system: External coolant with requisite flexible pipes on its snout is to be provided. The arrangement for its supply may be made through the coolant supply system available on the Head Stock.	Vendor to Confirm			
11.5.21	Details of the Boring head along with its drawing/sketch.	Vendor to submit			
11.6	ADDITIONAL ATTACHMENT				
11.6.1	The Vendor to offer any other attachment apart from attachments mentioned at S.no 11.2 to 11.5 to ensure successful machining of the Proveout Component as per S.no 20	Vendor to Note & Submit Details if applicable			
11.6.2	The offered additional attachment (if applicable) must comply following technical parameters	Vendor to offer if applicable			
11.6.3	Transmittable Power : 25 KW or more	Vendor to inform			
11.6.4	Resolution of any Continuous Swivelling Axis : 0.001 Deg (if applicable)	Vendor to inform			
11.6.5	Provision for External and Internal coolant	Vendor to inform			
11.6.6	Provision for manual tool loading and unloading	Vendor to inform			
11.6.7	Make & Model of Additional Attachment (if applicable) including drawing/sketch/catalogue pages showing major dimensions of the Head to be submitted with the offer.	Vendor to submit details			
11.7	CAM SIMULATION OF ATTACHMENTS				
11.7.1	The Vendor has to submit 3D CAM Simulation of Machining Strategy using all the attachments mentioned at S.no 11.2 to 11.6.	Vendor to confirm			
11.7.2	This CAM Simulation has to be provided after PO Placement.	Vendor to confirm			
11.8	MEASURING SYSTEM	Vendor to Offer			

Ashwini



Deep

DR

Sat

Deep

Sl. NO.	DESCRIPTION FOR BHEL REQUIREMENT	REQUIRED	OFFERED	DEVIATIONS	REMARKS
11.8.1	Vendor to offer Automatic Job Measuring System, comprising of Spindle mounted Renishaw or equivalent make Wireless system, with measuring cycles, calibration system and all types of probes/styli required for measuring all machined dimensions of proveout component mentioned at S.no 20. It should have following features	Vendor to confirm			
11.8.2	Latest RENISHAW/ probe	Vendor to confirm			
11.8.3	Holder for probe with taper suitable to the machine	Vendor to confirm			
11.8.4	Probe stylus (2 sets)	Vendor to confirm			
11.8.5	Calibration master including the calibrating programs. The calibration master should be fixed at suitable location so that calibration can be done without setting the master each time.	Vendor to confirm			
11.8.6	Requisite electronic interface	Vendor to confirm			
11.8.7	Receiver module	Vendor to confirm			
11.8.8	Service Kit	Vendor to confirm			
11.8.9	Spares Package for the Job Measuring system for 2 years trouble free working should also be offered. List to be submitted.	Vendor to confirm			
11.8.10	Format of report produced after measurement to be submitted. Format to be modified as per BHEL requirement if required.	Vendor to submit			
12	CAM SOFTWARE	Vendor to Offer			
12.1	Vendor to offer PC based latest version CAM Software (UG -NX or equivalent) suitable to generate tool path for 5 Axis machining strategy for complex airfoils.	Vendor to confirm and submit details			
12.2	The offered CAM Software should be able to import CAD models in different formats such as .igs, .iges, .x_t, .prt, .stp etc.	Vendor to confirm			
12.3	In addition to CAM software, Vendor to provide Post Processor of the supplied machine to generate tool path.	Vendor to confirm			
12.4	3D Model of Machine and all attachments mentioned at S.no 11.2 to 11.6 to be supplied with software. in order to simulate the tool path for checking collisions.	Vendor to confirm			
12.5	For this purpose, vendor to provide a suitable windows based PC with latest configuration suitable to run offered CAM software.	Vendor to confirm and submit details			
12.6	PC to be used in offline mode. CAM software should work in offline mode	Vendor to confirm			
12.7	CAM software License should not be restrictive to hardware of supplied PC. It should be provided in Dongle/Pendrive/CD Drive etc so that it may be transferred to another PC, if supplied PC corrupts/becomes obsolete.	Vendor to confirm			
12.8	Validity of CAM software License key to be lifetime or Vendor has to renew the provided License key every year without any financial implication to BHEL.	Vendor to confirm			
13	SPARES : (AS USED ON MACHINE)	Vendor to Offer			
13.1	Mechanical, Hydraulic & Lubrication System, Electrical and Electronic spares used on the machine are to be recommended and offered by the vendor in sufficient quantity for 2 years trouble free operation of the complete machine including CNC system and its accessories considering three shifts continuous running of the machine. Detailed list is to be submitted.	Vendor to agree, offer & submit details			
13.1.1	Following spare parts of electrical/electronics and CNC system shall be offered itemwise per machine (if not included in recommended spares):				
13.1.1.1	CNC Controller/NCU (as used in the machine) module- 1 No.	Vendor to offer			
13.1.2	PLC CPU/PCU, input and output cards- 1 No. each type	Vendor to offer			
13.1.3	Machine Control Panel (MCP)- 1 No.	Vendor to offer			
13.1.4	Limit Switches/ Micro Switches (2 Nos each type)	Vendor to offer			

SL. NO.	DESCRIPTION FOR BHEL REQUIREMENT	REQUIRED	OFFERED	DEVIATIONS	REMARKS
13.1.5	Relays and fusible relay boards (2 Nos each type)	Vendor to offer			
13.1.6	RTD temperature transmitter (1 No each type)	Vendor to offer			
13.1.7	Proximity Switches (5 Nos each type)	Vendor to offer			
13.1.8	Semiconductor Fuses (5 Nos each type)	Vendor to offer			
13.1.9	Special Fuses/Glass fuses (5 Nos each type)	Vendor to offer			
13.1.10	Main Power Switch (1 No each type)	Vendor to offer			
13.1.11	Secondary Encoders & connecting cables (1 No each type)	Vendor to offer			
13.1.12	Scanning Heads for Linear Scales (1 No each type)	Vendor to offer			
13.1.13	Wave shape unit/ EXE unit (if used) (1 No each type)	Vendor to offer			
13.1.14	Operator's panel with Display Unit (01 No. each type)	Vendor to offer			
13.1.15	Power Module / Servo amplifier & Control Cards for Main Drive as well as Feed Drives (1 Nos each type)	Vendor to offer			
13.1.16	Power cable and encoder cable (01 no. each type)	Vendor to offer			
13.1.17	One each of the following items : CNC Power Supply, Interface Modules, Hand Held Unit, Any other auxiliary drive , If used.	Vendor to offer			
13.1.18	UPS Module for CNC System safe shutdown-1 No	Vendor to offer			
13.1.19	Line Filter and Line Choke Module-1 No.	Vendor to offer			
13.1.20	Proportional Control Valve Controller 2 Nos. each type (if applicable)	Vendor to offer			
13.1.21	Push Buttons- 5 No. each type	Vendor to offer			
13.1.22	Indicating Lamp- 10 Nos each type	Vendor to offer			
13.1.23	Contactors- 2 Nos. each type	Vendor to offer			
13.1.24	Overloads/ Automats- 1 No. each type	Vendor to offer			
13.1.25	Machine Status Indicating Lamp (Complete unit) - 1 No	Vendor to offer			
13.1.26	Any special purpose / non-standard card - 01 No. each type	Vendor to offer			
13.1.27	Encoders, limit switches, proximity switches, reed switch, optical sensors used in attachments/head/AAC- 1 no. each type	Vendor to offer			
13.1.28	All types of spares for total machine and accessories should be available for at least ten years after supply of the machine. If machine or control is likely to become obsolete in this period, the vendor should inform BHEL sufficiently in advance and provide drawings of parts/ details of spares & suppliers to enable BHEL to procure these in advance, if required.	Vendor to confirm			
13.1.29	Repair service contract with supplier of CNC system for service & spares for motor drives, CNC Unit and Milling Spindle should also be offered by the vendor.	Vendor to offer			
13.1.30	Vendor to confirm that complete list of spares for machine and accessories, along with specification / type / model, and name & address of the spare supplier shall be furnished along with documentation to be supplied with the machine. Vendor to also confirm that documentation shall include list of all type of parts used along with specifications, type, model, quantity etc.	Vendor to confirm			
13.2	Mechanical , Hydraulic & Lubrication System Spares for 2 years trouble free operation of the complete machine (if not included in recommended spares offered by the vendor). Detailed list is to be submitted.	Vendor to offer			
13.2.1	Set of Gears for All the attachments used on the machine- 1 set of each type	Vendor to offer			
13.2.2	All pumps (one of each type) including Hydrostatic, Hydraulic, Lubrication and coolant circuit pumps & oil cooling pumps in the oil chilling units.	Vendor to offer			
13.2.3	All types of valves (2 Nos of each type) including D.C. control valves; Relieve valves, Reducing valves, Check valves, Flow control valves, Proportionate valves, pressure regulators, pressure reducer valves used in Hydrostatic, Hydraulic, Lubrication, coolant, Pneumatic circuit of the machine.	Vendor to offer			

Shankar
Besh
Suf
Kushal

SI. NO.	DESCRIPTION FOR BHEL REQUIREMENT	REQUIRED	OFFERED	DEVIATIONS	REMARKS
13.2.4	All types of pressure switches, flow switches and float switches; level indicator used in used in Hydrostatic, Hydraulic, lubrication, coolant, pneumatic circuit of the machine (2 no. each type)	Vendor to offer			
13.2.5	Hoses with crimp fittings used in Hydrostatic, Hydraulic, lubrication, coolant, pneumatic circuit of the machine - one set of each type.	Vendor to offer			
13.2.6	Set of seals (Piston, Shaft, Cylinder) & O rings (for all balancing, clamping cylinders & pistons) (2 Nos each type)	Vendor to offer			
13.2.7	Metering valves/progressive lubrication system blocks & seals	Vendor to offer			
13.2.8	All types of regenerative type filter inserts (5 No. of each type)	Vendor to offer			
13.2.9	All types of Disposable type filter inserts (10 nos. of each type)	Vendor to offer			
13.2.10	Set of all type of belts (including timing belts) (1 no. each type)	Vendor to offer			
13.2.11	O-Rings and Piston rings (5nos. of each type)	Vendor to offer			
13.2.12	Accumulator with charging kit if the same is used in the M/C (1 no each type). Booster kit is required if charging pressure is more than 80 bar.	Vendor to offer			
13.2.13	All types of pneumatic valves & proportional valves used on machine (1 no. of each type)	Vendor to offer			
13.2.14	All couplings including hydraulic, hydrostatic, lubrication pump couplings, pressure sleeves etc (2 nos. of each type)	Vendor to offer			
13.2.15	Spindle Taper Cone (1 No.)	Vendor to offer			
13.2.16	5 meter length of Chip Conveyor Chain.	Vendor to offer			
13.2.17	Rotary Coupling for Coolant through Spindle(1 no.)	Vendor to offer			
13.2.18	All Air Compressor spares to be provided along with the machine. The spares provided should facilitate trouble free operation of the unit for two years.	Vendor to offer			
13.2.19	Vendor shall provide all tool and tackles required for maintenance of the machine like Allen keys, Spanners, Torque Wrench, Special purpose tool etc.	Vendor to offer			
13.2.20	Special Oil/ Grease/ Cooling Agent (if any)- Sufficient qty. for 1 year (operation on 3 shift basis) along with grease Gun.	Vendor to offer			
13.2.21	Recommended Spares for 2 years for all attachments as mentioned in sl no. 11.2 to 11.6. Vendor to provide the list of offered spares.	Vendor to offer			
13.2.22	Recommended Spares for 2 years for AAC as mentioned in sl no. 11.1. Vendor to provide the list of offered spares.	Vendor to offer			
13.2.23	Any other recommended spare part essential for 2 years 3 shift trouble free working of machine should also be quoted with item wise price, specification and source of supply.	Vendor to offer			
13.2.24	Air Conditioning Spares for 2 years (on three shift basis: As applicable on machine) of trouble free operation of the all type of Panel Air Conditioners and refrigerant based Chiller Units.	Vendor to agree			
13.2.25	Refrigerant Compressor (1 no. for each type)	Vendor to offer			
13.2.26	Digital Temperature Controller (1 no. for each type)	Vendor to offer			
13.2.27	Condenser Fan (1 no. for each type)	Vendor to offer			
13.2.28	Evaporator Fan for Panel/ Cabinet AC (1 no. for each type)	Vendor to offer			
13.2.29	Pumps used in Chiller Unit (1 no. each type).	Vendor to offer			
13.2.30	Refrigerant Expansion Valve (1 no. for each type)	Vendor to offer			
14	DOCUMENTS: Following manuals/diagram/ list/ specifications shall be supplied in English language along with the machine documentation:	Vendor to offer			

Ashwini Dandekar

Prof. R.

Sgt. Prasad

Sl. NO.	DESCRIPTION FOR BHEL REQUIREMENT	REQUIRED	OFFERED	DEVIATIONS	REMARKS
14.1	4 hard copies of all Siemens/ Fanuc programming (Basic and Advance), Cycles, Tool management, all special procedure for AAC/Attachment etc. and all operational manuals shall be supplied in English language.	Vendor to offer			
14.2	Basic Machine operation and maintenance/ service manual (in English) - 4 copies	Vendor to offer			
14.3	Electrical schematic & wiring diagram of the machine with the list of all electrical electronics items used on machine- 4 copies	Vendor to offer			
14.4	PLC print-out in Operand form with comments in English- 4 copies	Vendor to offer			
14.5	GHOST back up of hard disk/memory card of CNC controller on CD / full backup on Hard disk as applicable.	Vendor to offer			
14.6	Complete list of parts used in the machine along with specification, part/ ordering numbers and address of manufacturer in case of purchased item- 4 copies.	Vendor to offer			
14.7	Detailed assembly drawing with clear marking of each component including Assembly drawing of spindle, attachments and giving reference of manufacturer of each assembly/sub-assembly- 3 copies.	Vendor to offer			
14.8	Hydraulic, Hydrostatic, Pneumatic, Lubrication and Coolant circuit diagram along with part list, complete specification and make of each element used— 3 copies.	Vendor to offer			
14.9	Wiring diagram indicating lay out of cables, plugs, junction boxes, terminal strips etc. - 3 sets	Vendor to offer			
14.10	List of all bearings, L.M. guides, ball bushings etc. with full specification and make- 3 sets.	Vendor to offer			
14.11	Alarm list and fault diagnostic manual- 4 sets	Vendor to offer			
14.12	Spare part list along with specification, part number and address of manufacturers- 4 sets.	Vendor to offer			
14.13	Service and user manuals of all bought out items- 4 sets.	Vendor to offer.			
14.14	CDs of provided control system documentation.	Vendor to offer			
14.15	Documents comprising Operating manuals, Signals, Interfacing and diagnostic guide of offered CNC System - 3 set	Vendor to offer			
14.16	Help guides for tele-diagnostic service systems- 3 sets	Vendor to offer			
14.17	PLC print out with comments in English(Hard copy) of auxiliary systems(if used)-3 sets.	Vendor to offer			
14.18	All O&M manuals including electrical schematic, wiring diagram, cable layout, junction box details and connector diagrams soft copy on CD/Pen Drive- 2 nos.	Vendor to offer			
14.19	O&M manuals shall include complete part list with make & specifications for compressor & refrigeration system.	Vendor to confirm			
14.2	O&M manuals shall include complete part list with make & specifications for stabiliser & isolation transformer.	Vendor to confirm			
14.21	Vendor to submit one set of all documents in best available condition one month prior to training cum pre acceptance of BHEL Engineers.	Vendor to confirm			
14.22	Sketches of all the attachments as per clause no 11.	Vendor to confirm			
14.23	Soft copies of all the above manuals to be provided.	Vendor to confirm			
15	TRAINING:				

Ashish Kumar

Deep

B

Sank

Prakash

SI. NO.	DESCRIPTION FOR BHEL REQUIREMENT	REQUIRED	OFFERED	DEVIATIONS	REMARKS
	<p>Four BHEL Persons should be trained at vendor's works for the area & period given below:</p> <p>(a) CNC 5 Axis Part Programming for components with 3 D geometry, application of all CNC Features, Programming for Measuring Systems & supplied accessories etc. (Period 2 Weeks)</p> <p>(b) Electrical, Electronic & CNC maintenance for machine & other supplied equipment's (Period 2 weeks)</p> <p>(c) Mechanical & Hydraulic maintenance of the machine & other supplied equipment's (Period 2 weeks)</p> <p>(d) Operation of the machine & other supplied equipment's (Period 2 weeks)</p> <p>Pre-dispatch inspection of the machine as per S.No 23.1 shall also be carried out by the team during their stay at vendor's works for the training. BHEL reserves the right to choose no. of persons, field & period of training, out of above, while deputing their engineers for training.</p>	Vendor to offer			
15.2	Air-fare, boarding & lodging for the trainees shall be borne by BHEL.	Vendor to note			
15.3	Competent, English speaking experts shall be arranged by the vendor during training for satisfactory & effective training of BHEL personnel.	Vendor to confirm			
15.4	Vendor to quote for Training on per man per day basis	Vendor to offer			

Ashwini Dourvedh

Prof. Dr. S. K. Sankar

Sl. NO.	DESCRIPTION FOR BHEL REQUIREMENT	REQUIRED	OFFERED	DEVIATIONS	REMARKS
16	<p>FOUNDATION:</p> <p>Vendor shall submit the preliminary layout drawing for getting BHEL's approval within one month from the date of Letter of Intent (LOI) / P.O. Final Layout and complete civil drawings for foundation of machine shall be submitted by the supplier within three months after getting BHEL's approval. The layout should consist of all requirements pertaining to complete machine including space requirement for Voltage Stabilizer, Isolation Transformer, Air compressor, Chip Bin & any other accessories. The civil drawings shall cover complete details of foundation viz. Details of Reinforcement, grade of concrete, plain Cement Concrete and any other details required as per existing bearing capacity of soil, position and size pockets in top bed of foundation, details of trenches, depression (if any), provision of fixtures, protection mechanism for vibration isolation /settlements. BHEL shall construct complete foundation for the machine under supervision of vendor and at vendor's responsibility. The vendor shall also indicate detailed specifications of grouting compound and Grouting procedure etc. for foundation bolts of the machine. Vendor shall arrange required facilities for the testing of foundation at his own cost (if requirement arises).</p> <p>Soil condition data at BHEL, Hardwar is as detailed below:</p> <p>Based on the block resonance test, the dynamic soil parameters are as below:</p> <p>(i) $C_u = 4.937 \text{ kg/cm}^3$ (For block size of 1.5m x 1m x 1m) $C_u = 1.667 \text{ kg/cm}^3$ (For foundation size of 10m² or more.) (ii) $C_D = 9.70 \text{ kg/cm}^3$ (iii) $C_P = 4.20 \text{ kg/cm}^3$</p> <p>16.2 Bearing Capacity: Depth : 5 M From Shear consideration : 39 T/M² From Settlement consideration : 9-10 T/M² Recommended B.Capacity : 9 T/M²</p>	<p>Vendor to confirm</p> <p>Vendor to agree</p>			
17	<p>ERECTION & COMMISSIONING:</p> <p>Supplier to take full responsibility for carrying out the erection, start up, testing of machine, it's control system & all types of other supplied equipment, machining of test pieces etc. and formalities for its experts deployed for E&C (including VISA, travel, boarding, lodging, insurance etc). Service requirement like power, air & water shall be provided by BHEL at only one point to be indicated by supplier in their foundation/layout drawings. Other requirements like crane and helping personnel shall also be provided by BHEL. Details of these requirements should be informed by vendor in advance. The available crane capacity at the proposed location of the machine will be 150 Ton. The vendor will ensure to make requisite arrangement for lifting of heavier consignment/ items/ assembly of the machine not getting covered by this capacity.</p>	<p>Vendor to offer</p> <p>Vendor to confirm</p>			
17.1	<p>foundation/layout drawings. Other requirements like crane and helping personnel shall also be provided by BHEL. Details of these requirements should be informed by vendor in advance. The available crane capacity at the proposed location of the machine will be 150 Ton. The vendor will ensure to make requisite arrangement for lifting of heavier consignment/ items/ assembly of the machine not getting covered by this capacity.</p>	<p>Vendor to confirm</p>			
17.2	<p>Erection & Commissioning of Voltage stabilizer, Isolation Transformer & Air Compressor shall also be responsibility of the vendor.</p>	<p>Vendor to confirm</p>			
17.3	<p>Successful proving of BHEL components by the supplier shall be considered as part of commissioning. All tests, as mentioned at S.No 23 (Machine Acceptance) shall form part of the commissioning activity.</p>	<p>Vendor to confirm</p>			

SI. NO.	DESCRIPTION FOR BHEL REQUIREMENT	REQUIRED	OFFERED	DEVIATIONS	REMARKS
17.4	Test mandrel for checking run-out/laper & alignment should be supplied Tools, Tackles, Test Mandrels, Instruments and other necessary equipment including Laser equipment required to carry out all above activities should be brought by the supplier. Special Tools/fixtures required to check & align the accuracy of machine shall be supplied.	Vendor to confirm			
17.5	Commissioning spares, required for commissioning of the machine within stipulated time, shall be brought by the supplier on returnable basis.	Vendor to confirm			
17.6	All Cover Plates required for the machine and its peripherals including pits, if any, shall be supplied and installed by the vendor.	Vendor to confirm			
17.7	The vendor shall supply sufficient quantity of paint of the machine and carry out touching wherever the paint is damaged during transit or erecting of the machine.	Vendor to confirm			
17.8	Schedule of Erection and Commissioning shall be submitted with the offer.	Vendor to submit			
17.9	Charges, duration, terms & conditions for E&C should be furnished in detail separately by vendor along with offer.	Vendor to offer			
17.10					
18	ACCURACY TESTS:				
18.1	Geometrical Accuracy Geometrical Accuracy Tests shall be in accordance with ISO-230-1-2012 / IN/ITMSA-2-1987 test code /ISO 3070 / 8636-2/DIN 8609/ISO 10791/ISO3655 standard or equivalent applicable standard.	Vendor to confirm & submit details			
18.1.1	Detailed Test Charts for the same, clearly showing the accuracies to be achieved on the machine, shall also be submitted with the offer.				
18.1.2	All the above Geometrical accuracies to be demonstrated to BHEL engineers during pre-acceptance at Suppliers works and during Erection & Commissioning at BHEL Works	Vendor to Confirm			
18.2	Positioning Accuracies and Repeatability				
18.2.1	The measurement of accuracy of positioning and repeatability of all traversing axes of the machine should be as per VDI/ DGQ 3441 using LASER INTERFEROMETER (To be arranged by vendor on returnable basis)	Vendor to Confirm			
18.2.2	Positional Accuracy (Pa) for Linear Axis Positional Accuracy (Pa) for Linear Axis 1(Axis along Cross Rail) per 1000 mm should be less than equal to 0.015mm	Vendor to Specify			
18.2.2.1	Positional Accuracy (Pa) for Linear Axis 2 (Axis Perpendicular to Cross rail) per 1000 mm should be less than equal to 0.015mm	Vendor to Specify			
18.2.2.2	Positional Accuracy (Pa) for Z Axis per 1000 mm should be less than equal to 0.015mm	Vendor to Specify			
18.2.2.3	Positional Uncertainty (P) for entire stroke in all Linear Axes	Vendor to Specify			
18.2.2.4					
18.2.3	Repeatability/Positional Scatter(Ps) for Linear Axis				
18.2.3.1	Repeatability/Positional Scatter(Ps) for Linear Axis 1(Axis along Cross Rail) per 1000 mm should be less than equal to 0.012mm	Vendor to Specify			
18.2.3.2	Repeatability/Positional Scatter(Ps) for Linear Axis 2((Axis Perpendicular to Cross rail) per 1000 mm should be less than equal to 0.012mm	Vendor to Specify			
18.2.3.3	Repeatability/Positional Scatter(Ps) for Z Axis per 1000 mm should be less than equal to 0.012mm	Vendor to Specify			





Sl. NO.	DESCRIPTION FOR BHEL REQUIREMENT	REQUIRED	OFFERED	DEVIATIONS	REMARKS
18.2.4	Positional Accuracy (Pa) & Repeatability/Positional Scatter for Table Rotary Axis (If Applicable)				
18.2.4.1	Positional Accuracy (Pa) for Table Rotation Axis to be less than 10 Arc seconds	Vendor to Specify			
18.2.4.2	Repeatability / Positional Scatter (Ps) for Table Rotation Axis to be less than 8 Arc seconds	Vendor to Specify			
18.2.5	All the above Positioning accuracies & Repeatability to be demonstrated to BHEL engineers during pre-acceptance at Suppliers works and during Erection & Commissioning at BHEL Works.	Vendor to confirm			
18.3	Accuracy for Rotary Axis in Attachments				
18.3.1	Accuracy for "A"/"B" Continuous Swivelling Axis over entire stroke of attachments mentioned at S.no 11.2 & 11.3 : Less than 10 Arc seconds as per ISO-230-2-2014	Vendor to Specify			
18.3.2	Accuracies of "A/B" Continuous Swivelling Axis to be demonstrated to BHEL engineers during pre-acceptance at Suppliers works and during Erection & Commissioning at BHEL Works	Vendor to Specify			
18.4	NAS Test Piece Machining	Vendor to Offer			
18.4.1	Machining of NAS Test Piece as per standard NAS-979 at vendor's work & at BHEL. Hardwar to be carried out by the vendor The NAS test piece & tooling for its machining shall be provided by the vendor at their works as well as at BHEL, Hardwar. Details of NAS test piece to be submitted with the offer.	Vendor to confirm & submit details			
18.4.2	Since the machine shall be installed in shop with operating conditions as per clause No 19, the vendor shall guarantee achieving the above mentioned accuracies throughout the year.	Vendor to confirm			
19	AMBIENT CONDITIONS & THERMAL STABILITY : Total machine including CNC system and all supplied items should work trouble free and efficiently under following operating conditions and should give specified accuracies Power Supply (AC) : Voltage: 415 V - 10%, +10% Frequency: 50 Hz +/- 3% No. of phases = 3 phase (3 wire system without neutral) Ambient Operating Conditions: Temperature = 5 to 45 degree Celsius Relative Humidity = 95% max. (Vendor to confirm that machine is suitable for above)	Vendor to take note			
19.2	Weather conditions are tropical. Atmosphere may be dust laden during some part of the year. Machine shall be kept in the normal shop floor condition. Max. temperature variation is up to 25 deg Celsius in 24 hours. (Vendor to confirm that machine is suitable for above and details of provisions on the machine for the same are to be furnished by Vendor).	Vendor to confirm			

Ashar Davel

Roof

D

Smt

Pradyumn

Sl. NO.	DESCRIPTION FOR BHEL REQUIREMENT	REQUIRED	OFFERED	DEVIATIONS	REMARKS
19.3	Thermal Stability of the complete machine keeping in view specified Ambient Conditions and accuracy requirements of BHEL components and trouble free operation of the machine should be ensured by vendor. (Vendor to confirm that machine is suitable for above and details of provisions on the machine for the same should be furnished by Vendor).	Vendor to confirm			
19.4	The equipment for refrigeration type cooling and electric heating (if needed) for re-circulating lubricating oil, spindle head oil and hydraulic system oil for tropical temperature fluctuations, as indicated at clause no. 19.1, of sufficient capacity should be offered with detailed specifications.	Vendor to submit details			
19.5	The machine, including attachments and accessories, should be suitable for 24 hrs. continuous operation to its full capacity for 24 hour a day and 7 days a week throughout. Vendor to ensure and confirm the same.	Vendor to confirm			
20	PROVEOUT OF COMPONENTS AT BHEL, HARDWAR:	Vendor to Offer			
20.1	A monoblock multibladed Turbofan with Outer Dia 5m or more will be prove out component. Job setting plan, Machining process plan & Requirement of Tools, fixtures, attachments etc. for machining of prove out components shall be discussed and mutually agreed with vendor. Information regarding geometry of Prove out Component will be provided on need to know basis during Pre Bid Meeting to be held at BHEL, Haridwar. Vendors would be required to sign an NDA for Pre Bid meeting. A MoM mentioning the information shared with Vendor during PreBid meeting would be recorded and be part of the PO. Vendor to confirm in MoM that offered Machine along with accessories, toolings and fixtures would be suitable to machine proveout components.	Vendor to Note			
20.2	Vendor shall submit final job setting plan, machining process plan, tool, fixtures & attachments layout & list with complete description, time study etc. for the prove out machining within two months of placement of order.	Vendor to Confirm			
20.3	Complete machining of Prove out Component shall be done by the Vendor at BHEL, works after complete erection, performance tests & test piece machining etc.	Vendor to Confirm			
20.4	The Vendor needs to develop CAM toolpath and CNC programs for machining Prove out Component at BHEL Premises on BHEL PC/Workstations supplied as S.No 12.5, only in presence of BHEL Programmers. No data including drawings, CAD Model, CAM toolpath, CNC Programs etc. shall be transferred to Vendor's Laptop or any storage device.	Vendor to Confirm			
20.5	The material for the prove out components shall be provided by BHEL.	Vendor to Note			
20.6	There shall be "IN PROCESS" inspection of the machined component using Rensshaw Probe being provided with the machine as per clause no 11.9.	Vendor to Note			
20.7	The vendor shall be responsible, financially or otherwise, for any deviation/ rejection in prove out components to the extent of its cost, due to wrong machining or malfunctioning of the machine during prove out machining and also for the delay in machining due to improper recommended tooling etc. The cost of such deviation / rejection, if any, shall be refunded by the vendor to BHEL.	Vendor to Confirm			
20.8		Vendor to Confirm			
21	PROVEOUT TOOLINGS:	Vendor to Offer			

Ashwani Dhar *Prof. Dr. Smt. Prof. Dr.*

Sl. NO.	DESCRIPTION FOR BHEL REQUIREMENT	REQUIRED	OFFERED	DEVIATIONS	REMARKS
21.1	Complete set of Tools, Cutter bodies & Tool-Holders in sufficient quantity required for machining of prove-out component mentioned at clause no.: 20 should be offered with item wise price & description supplied along with machine.	Vendor to confirm, offer & submit details			
21.2	Consumables like inserts, screws, solid carbide & HSS cutters, etc. should be separately quoted and offered for machining of 2 nos of prove out components along with the machine.	Vendor to confirm, offer & submit details			
21.3	For all tools, sketches/ copy of catalogue pages should be provided.	Vendor to confirm & submit details			
21.4	While finalising tools, vendor to take care of following points :				
21.4.1	It is advisable to use long tool holders with standard length tools instead of longer length of cutting tools to meet the requirement of long working length wherever it is possible. HSS tools to be avoided wherever possible.	Vendor to confirm			
21.4.2	Tools of reputed tools manufacturer whose tools are easily available in India, to be used for prove-out of components.	Vendor to confirm			
21.4.3	Preliminary list of offered tools/ tool holders / accessories are to be submitted with the offer. In case of order, final drawings of special items & copy catalogue pages of standard items shall be submitted to BHEL, after placement of PO.	Vendor to confirm			
21.4.4	Tool Storage Cabinets & Tool stands for Milling tools (set of four nos, each type) of reputed (Indian) make having covered heavy duty drawers of suitable sizes with lock facility to store offered tooling items etc.	Vendor to offer			
22	FIXTURES				
22.1	A suitable fixture capable of clamping prove out component as per Clause no 20 should be offered with item wise price & description. The fixture needs to be supplied along with the machine.	Vendor to confirm, offer & submit details			
22.2	Consumables like screws, nuts, clamping heads, etc. should be separately quoted as a set and 2 more sets in addition to the set mounted on fixture should be offered with the machine.	Vendor to confirm, offer & submit details			
22.3	Sketches/ copy of catalogue pages of the fixture should be provided.	Vendor to confirm & submit details			
23	MACHINE ACCEPTANCE:	Vendor to note & Offer			
23.1	PDI: Pre Dispatch Inspection Tests/Activities to be carried out at vendor's works by vendor on the machine before dispatch using spindle & attachments :	Vendor to note			
23.1.1	Geometrical Accuracy Tests as per clause No 18.1	Vendor to confirm			
23.1.2	Positioning Accuracy Tests as per clause No 18.2	Vendor to confirm			
23.1.3	Accuracy of Swivelling Axis "A/B" of attachments	Vendor to confirm			
23.1.4	The machine should be tested for continuous running of 48 hrs. If any break down occurs during this test, the test should be repeated for 48 hrs from that time.	Vendor to confirm			
23.1.5	Demonstration of all features of the machine, CNC system and all Accessories.	Vendor to confirm			
23.1.6	Machining of NAS Test Piece clause No 18.4. Vendor to supply test piece & tooling for its machining.	Vendor to confirm			
23.2	Test to be carried out by Vendor at BHEL works post delivery of the machine using spindle & attachments :	Vendor to note			
23.2.1	Geometrical Accuracy Tests as per clause No 18.1	Vendor to confirm			
23.2.2	Positioning Accuracy Tests as per clause No 18.2	Vendor to confirm			
23.2.3	Accuracy of Swivelling Axis "A/B" of attachments	Vendor to confirm			

Arvind

Geet

Dr.

Suf

Prakash

SI. NO.	DESCRIPTION FOR BHEL REQUIREMENT	REQUIRED	OFFERED	DEVIATIONS	REMARKS
23.2.4	The machine should be tested for continuous running of 48 hrs. If any break down occurs during this test, the test should be repeated for 48 hrs from that time.	Vendor to confirm			
23.2.5	Demonstration of all features of the machine, CNC system & all accessories to the satisfaction of BHEL, for their efficient and effective use.	Vendor to confirm			
23.2.6	Machining of NAS Test Piece clause No 18.4. Vendor to supply test piece & tooling for its machining.	Vendor to confirm			
23.2.7	Demonstration by actual use of all supplied attachments and accessories to their full capacity.	Vendor to confirm			
23.2.8	Successful job prove out of BHEL component as per clause 20	Vendor to confirm			
23.2.9	Two weeks supervision of independent operation of machine by BHEL after job prove out.	Vendor to confirm			
23.2.10	Training of BHEL machine operators in operation of complete machine & accessories etc. through association of the operator with vendor's expert during commissioning and job prove out during their stay at BHEL works.	Vendor to confirm			
24	PACKING:	Vendor to offer			
24.1	Sea worthy & Road worthy rigid packing for all items of complete machine, CNC System, all accessories and other supplied items to avoid any damage/loss in transit. When machine is dispatched in containers, all small loose items shall be suitably packed in boxes.	Vendor to confirm			
25	GUARANTEE:	Vendor to offer			
25.1	Guarantee for 2 years of complete machine and attachments/accessories from date of acceptance of machine.	Vendor to confirm			
26	GENERAL				
26.1	The Layout of the machine is to be designed ergonomically, ensuring that Job Loaded on the Rotary Table (if applicable), Operator panel etc. are easily accessible. Any platforms for accessing the machine and covering of open spaces shall be within the scope of Vendor	Vendor to confirm			
26.2	Ladder, at suitable location, is to be provided to access the machine elements located at the top of the column as well as movement of operator from/to Operator's platform in case of power failure or any other emergency.	Vendor to offer & confirm			
26.3	The vendor should reproduce the specification and submit compliance / agreement / comment against each and every feature/item. Any deviation in the offer should be clearly highlighted against that particular item/feature.	Vendor to confirm			
26.4	Supplier should submit following details along with the technical offer :				
26.4.1	Total connected load of machine and its peripherals (KVA).	Vendor to submit details			
26.4.2	Floor area required (Length, Width, Height) for complete machine & accessories.	Vendor to submit details			
26.4.3	Proper Layout drawing to be submitted along with the offer.	Vendor to submit details			
26.4.4	Weight of the machine and its major assemblies	Vendor to submit details			
26.4.5	Weight of the heaviest part & sub-assembly of the machine.	Vendor to submit details			
26.4.5	Dimensions of largest part/ subassembly/ assembly of the machine	Vendor to submit details			
26.4.6	Hardness of the Guideways.	Vendor to submit details			
26.4.7	Size and details of the lead screws / ball screws.	Vendor to submit details			
26.4.8	Detailed catalogues, sketch / photographs of the M/c and accessories / attachments should be submitted with the offer.	Vendor to submit details			
26.5	Colour of the machine, RAL 6011, Apple Green (Polyurethane Paint)	Vendor to confirm			

Ashwin Dhanraj

Deep

DR

Sat

Inspected

Sl. NO.	DESCRIPTION FOR BHEL REQUIREMENT	REQUIRED	OFFERED	DEVIATIONS	REMARKS
26.6	Hydraulic, Pneumatic & oil piping's should be preferably metallic except places where flexible piping's are essential. All the pipes required for the same shall be included in the standard scope of the machine.	Vendor to specify			
26.7	In case of order, vendor shall supply the preventive maintenance work schedule/ requirement/ charts for the complete machine	Vendor to confirm			
26.8	Vendor shall send bi-monthly progress report with digital photographs of machine, its major components and Sub-Assemblies for appraisal of progress of the machine by BHEL.	Vendor to confirm			
26.9	There shall be joint inspection of delivered machine/packages at BHEL Haridwar after receipt and before taking up Erection of machine	Vendor to confirm			
27	NETWORKING:	Vendor to Offer			
27.1	Machine control should have necessary hardware and software including cables so that it is ready for interfacing with gigabit Ethernet Local Area Network with 100 MB/sec. speed available on machine on UTP cables for NC program and other related data transfer. This network to be connected to wide area network/Internet. The networking should have following capabilities:	Vendor to confirm			
27.2	The machine shall appear as a node in the Entire Network (Network Neighbourhood)	Vendor to confirm			
27.3	The program transfer shall be by simple copy and paste method provided sharing access is allowed between any PC and the machine across the network.	Vendor to confirm			
27.4	The program transfer between CNC system and network should also be possible in CNC Mode.	Vendor to confirm			
27.5	The above capability of NC Program and other file/data transfer across network shall be established and demonstrated by the vendor during machine commissioning.	Vendor to confirm			
28	MACHINE MONITORING SYSTEM (MMS) SIGNALS	Vendor to Offer			
28.1	The supplied CNC system shall have OPC-UA compliance with valid licence.	Vendor to confirm			
29	PRE-QUALIFYING REQUIREMENT (PQR):				
29.1	Only those vendors (OEMs) should quote who have supplied & commissioned in the past (10) years (on the date of opening of Tender) at least one number of 5 AXIS CNC VERTICAL MACHINE of same or higher sizes (Milling Spindle 80 KW or More, Rotary Table size 5.5 M or more /Fixed Bed Plate 5.5mx6m or more(whichever is applicable), Hydrostatic Guideways, Special Attachments with one or more continuous machining axis and simultaneous 5 Axis Machining Capabilities, accuracies as per S.no 18) and have supplied solutions to machine components larger than 2 m having 3D Profiles such as Blades/Impellers/Blisks/Stationary Bladed Rings etc. with high accuracy, either (a) in at least one country other than the country from where the machine tool will be supplied to establish vendor's (OEM's) global business activity or (b) in India; and referred machine is presently working satisfactorily for more than one year after commissioning (on the date of opening of Tender).	Vendor to confirm			

Ashish Datta

Pradeep

B

Suf

Manoj

SI. NO.	DESCRIPTION FOR BHEL REQUIREMENT	REQUIRED	OFFERED	DEVIATIONS	REMARKS
29.2	However, such Indian machine tool vendors (OEMs), who do not meet specified qualifying conditions, can quote if they have running Collaboration/ Joint Venture/ Joint Working Arrangement for manufacture of 5 AXIS CNC VERTICAL MACHINE of same or higher sizes (Milling Spindle 80 KW or More, Rotary Table size 5.5 M or more /Fixed Bed Plate 5.5mx6m or more(whichever is applicable), Hydrostatic Guideways, Special Attachments with one or more continuous machining axis and simultaneous 5 Axis Machining Capabilities, accuracies as per S.no 18)	Vendor to confirm			
29.3	and have supplied solutions to machine components larger than 2 m having 3D Profiles such as Blades/Impellers/Blisks/Stationary Bladed Rings etc. with foreign machine tool manufacturer, who meets specified qualifying conditions. Such Indian machine tool vendors (OEMs) shall have to submit from their foreign partner a back to back guarantee for satisfactory performance of the offered machine in compliance to all specified tender requirements. BHEL reserves the right to accept or reject the OEMs based on the assessment of their technical and financial capability. In respect of Indian vendors (OEMs) as per 29.2, BHEL reserves the right to accept or reject both the Indian vendors (OEMs) & their Foreign Partners based on the assessment of their technical and financial capability.	Vendor to confirm			
29.4	The following information should be submitted by the vendor about the companies where referred machine (s) have been supplied. This is required from all the vendors for qualification of their offer.				
29.4.1	Name of the customer / company where referred machine is installed.	Vendor to inform			
29.4.2	Complete postal address of the customer.	Vendor to inform			
29.4.3	Month & Year of commissioning	Vendor to inform			
29.4.4	Parameters of machine(s) supplied and application for which the machine is supplied	Vendor to inform			
29.4.5	Name and designation of the contact person of the customer.	Vendor to inform			
29.4.6	Phone, FAX no. and email address of the contact person of the customer.	Vendor to inform			
29.4.7	Performance certificate from the customers regarding satisfactory performance of machine supplied to them (Original Certificate or through E-mail directly from the customer). The original performance certificate may be returned after verification by BHEL, if required.	Vendor to submit			
29.4.8	PO copy (unpriced acceptable) of the machine supplied to customer (Original PO or through E-mail directly from the customer). The original PO may be returned after verification by BHEL, if required.	Vendor to submit			
29.4.9	BHEL reserves the right to verify the information provided by the Vendor for the referred machine at their referred customer's works including machining accuracies. It shall be the responsibility of the vendor to facilitate the visit of BHEL's team at their referred customer works. The Travel and Boarding expenses for BHEL Personnel shall be borne by BHEL. In case the information provided by vendor is found to be false/ incorrect, the offer shall be rejected.	Vendor to accept & confirm			

Ashwan Divedi
ASHWAN DWIVEDI
DY. MGR/INT.

Rajesh Kumar
RAJESH KUMAR
DY. MGR (MIS) (CNC MACHS)

Prakash K. Sarda
PRAKASH K. SARDA
DY. MGR/INT.

Sudhakar Kumar
SUDHAKAR KUMAR
DY. MGR (MIS)

Prakash K. Sarda
PRAKASH K. SARDA
DY. MGR/INT.

PQR FOR INDENT 20234312 REV 00

SI. NO.	DESCRIPTION FOR BHEL REQUIREMENT	REQUIRED	OFFERED	DEVIATIONS	REMARKS
1	PRE-QUALIFYING REQUIREMENT (PQR):				
1.1	<p>Only those vendors (OEMs) should quote who have supplied & commissioned in the past (10) years (<i>on the date of opening of Tender</i>) at least one number of 5 AXIS CNC VERTICAL MACHINE of same or higher sizes</p> <p>(Milling Spindle 80 KW or More, Rotary Table size 5.5 M or more /Fixed Bed Plate 5.5mx6m or more(whichever is applicable), Hydrostatic Guideways, Special Attachments with one or more continuous machining axis and simultaneous 5 Axis Machining Capabilities, accuracies as per S.no 18)</p> <p>and have supplied solutions to machine components larger than 2 m having 3D Profiles such as Blades/Impellers/Blisks/Stationary Bladed Rings etc. with high accuracy, either (a) in at least one country other than the country from where the machine tool will be supplied to establish vendor's (OEM's) global business activity or (b) in India; and referred machine is presently working satisfactorily for more than one year after commissioning (on the date of opening of Tender).</p>	Vendor to confirm			
1.2	<p>However, such Indian machine tool vendors (OEMs), who do not meet specified qualifying conditions, can quote if they have running Collaboration/ Joint Venture/ Joint Working Arrangement for manufacture of 5 AXIS CNC VERTICAL MACHINE of same or higher sizes</p> <p>(Milling Spindle 80 KW or More, Rotary Table size 5.5 M or more /Fixed Bed Plate 5.5mx6m or more(whichever is applicable), Hydrostatic Guideways, Special Attachments with one or more continuous machining axis and simultaneous 5 Axis Machining Capabilities, accuracies as per S.no 18)</p> <p>and have supplied solutions to machine components larger than 2 m having 3D Profiles such as Blades/Impellers/Blisks/Stationary Bladed Rings etc. with foreign machine tool manufacturer, who meets specified qualifying conditions. Such Indian machine tool vendors (OEMs) shall have to submit from their foreign partner a back to back guarantee for satisfactory performance of the offered machine in compliance to all specified tender requirements.</p>	Vendor to confirm			
1.3	<p>BHEL reserves the right to accept or reject the OEMs based on the assessment of their technical and financial capability.</p> <p>In respect of Indian vendors (OEMs) as per 29.2, BHEL reserves the right to accept or reject both the Indian vendors (OEMs) & their Foreign Partners based on the assessment of their technical and financial capability.</p>	Vendor to confirm			
1.4	The following information should be submitted by the vendor about the companies where referred machine (s) have been supplied. This is required from all the vendors for qualification of their offer.				
1.4.1	Name of the customer / company where referred machine is installed.	Vendor to inform			
1.4.2	Complete postal address of the customer.	Vendor to inform			
1.4.3	Month & Year of commissioning	Vendor to inform			
1.4.4	Parameters of machine(s) supplied and application for which the machine is supplied	Vendor to inform			

SI. NO.	DESCRIPTION FOR BHEL REQUIREMENT	REQUIRED	OFFERED	DEVIATIONS	REMARKS
1.4.5	Name and designation of the contact person of the customer.	Vendor to inform			
1.4.6	Phone, FAX no. and email address of the contact person of the customer.	Vendor to inform			
1.4.7	Performance certificate from the customers regarding satisfactory performance of machine supplied to them (Original Certificate or through E-mail directly from the customer). The original performance certificate may be returned after verification by BHEL, if required.	Vendor to submit			
1.4.8	PO copy (unpriced acceptable) of the machine supplied to customer (Original PO or through E-mail directly from the customer). The original PO may be returned after verification by BHEL, if required.	Vendor to submit			
1.4.9	BHEL reserves the right to verify the information provided by the Vendor for the referred machine at their referred customer's works including machining accuracies. It shall be the responsibility of the vendor to facilitate the visit of BHEL's team at their referred customer works .The Travel and Boarding expenses for BHEL Personnel shall be borne by BHEL. In case the information provided by vendor is found to be false/ incorrect, the offer shall be rejected.	Vendor to accept & confirm			

FINANCIAL PQR FOR TENDER ENQUIRY NO. 2890/C/6410/4312/T1 for VERTICAL CNC 5 AXIS MILLING MACHINE -01 NO.			
SL. NO.	DESCRIPTION	BIDDER TO CONFIRM	WHETHER DOCUMENTS SUBMITTED
1	BIDDER SHOULD HAVE AVERAGE ANNUAL TURNOVER OF MINIMUM RS. 23.13 CRORES DURING LAST THREE CONSECUTIVE FINANCIAL YEARS I.E. FY 2021-22, 2022-23 & 2023-24 DULY SUPPORTED BY VALID UDIN NUMBER.		
2	BIDDER TO SUBMIT LATEST INCOME TAX RETURN AND BALANCE SHEET & PROFIT & LOSS ACCOUNT STATEMENT OF LAST THREE CONSECUTIVE FINANCIAL YEARS I.E. FY 2021-22, 2022-23 & 2023-24 DULY SUPPORTED BY VALID UDIN NUMBER.		
3	BIDDER SHOULD HAVE POSITIVE NET WORTH DURING LAST THREE CONSECUTIVE FINANCIAL YEARS I.E. FY 2021-22, 2022-23 & 2023-24.		

NOTE: Note: In case of non-filing the ITR of FY 2023-24 in accordance with relaxation of due date under Government direction, financial year considered as 2020-21, 2021-22 & 2022-23.

(Signature of Bidder with Company Stamp)

SPECIAL ATTACHMENTS

ATTACHMENT 1: (S.NO 11.2 OF TENDER SPECIFICATIONS)

MILLING HEAD WITH CONTINOUS SWIVELLING AXIS FOR MACHINING 3D SURFACES

Milling Head with Continuous Milling Axis (“A” or “B”)

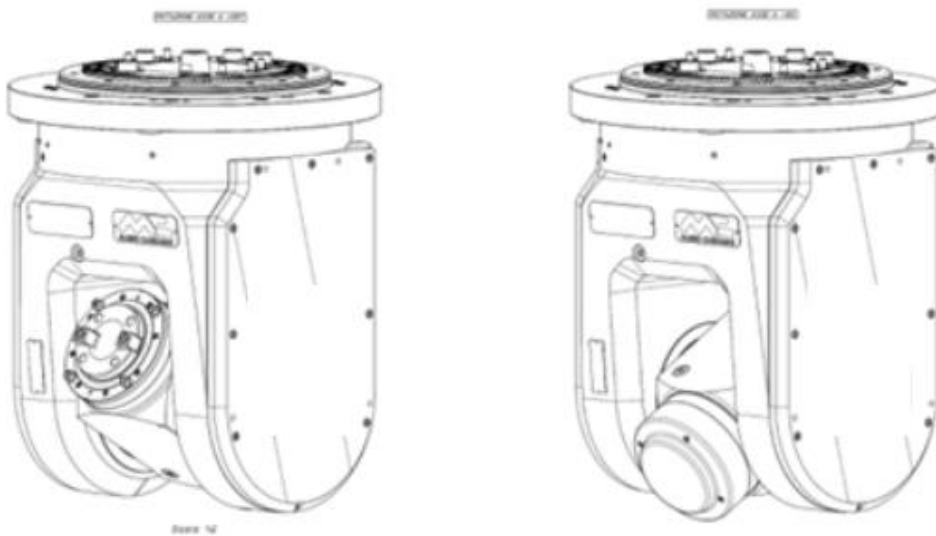

Fig 1: Schematic View of Continuous Milling Head (For Reference)



Fig 4: Schematic View of special 45 Degree Continuous Head to machine narrow zones between blades (For Reference)

ATTACHMENT 3: LONG VERTICAL HEAD

(S.NO 11.4 OF TENDER SPECIFICATIONS)

The purpose of this Long Vertical Head is to do rough machining on the Blade Profiles to ensure that there is less & uniform material to be removed by Special Heads/Attachments

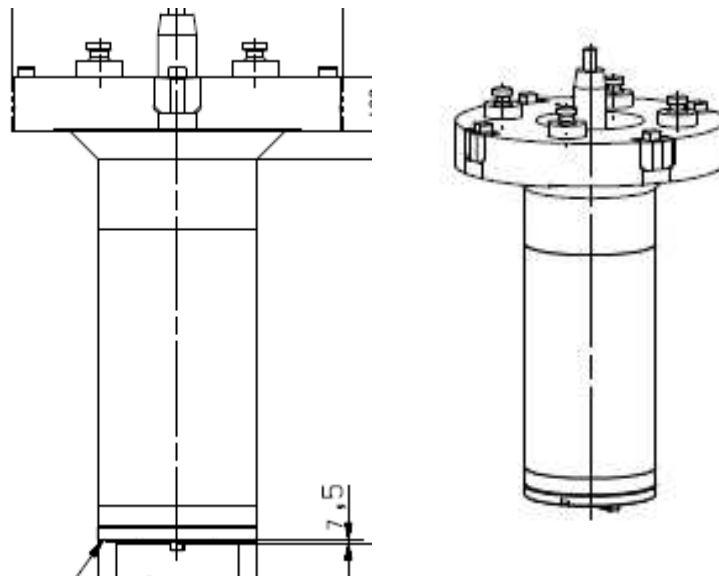

Fig 5: Schematic View of Long Vertical Milling Head (For Reference)

ATTACHMENT 4: SPECIAL BORING AND FACING HEAD

(S.NO 11.5 OF TENDER SPECIFICATIONS)

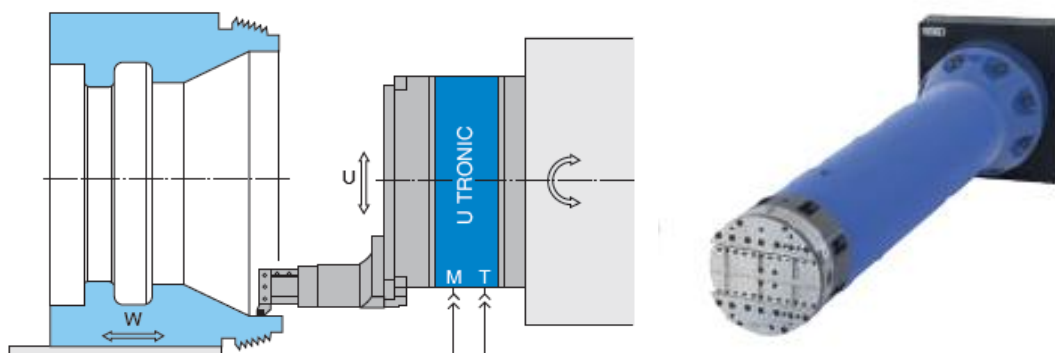

Fig 6: Concept of Special Boring & Facing Head (For Reference)

Activity Schedule for Vertical 5 Axis CNC Milling Machine			
Indent No. 20234312 ; dated 28.03.2024		Material code: ZWA170101010	
Name/Address & other details of Bidder:-			
Sl. No.	Activity	Activity Time in Weeks	Remarks if Any
1	Acceptance of PO		Vendor to inform
2	Submission of Documents necessary for getting manufacturing clearance like Civil Drawing, Foundation Drawings and other layouts drawings	4	Post placement of PO
3	Comments on Documents from BHEL	2	
4	Final Layout drawings submitted by the vendor		The upper cap limit for activity mentioned in sl no. 4 shall be 12 weeks, however if any bidder wants to quote less than 12 weeks, than he can quote in left column else the activity time given by BHEL as 12 week shall be final.
5	Manufacturing Time of Machine		Vendor to inform
6	Inspection Call by Vendor		At least 45 days before the PDI date
7	Pre- Dispatch Inspection by BHEL and dispatch clearance	2	
8	Delivery at BHEL haridwar		Vendor to inform. Delivery Date at BHEL Haridwar not to exceed 14 Oct 2026.
9	E&C Milestone 1: Readiness of Machine to commence machining Post Delivery. Erection, Installation, Performance Tests,NAS test Piece Machining	15	Date for completing Milestone 1 not to exceed 12 March 2027.
10	E&C: Milestone 2: Job Proveout	17	Post availability of Rough Casting

Annexure (Non-Disclosure Agreement)

1

NON-DISCLOSURE AND PROPRIETARY INFORMATION AGREEMENT

BETWEEN

_____ (Name of the Vendor), having its registered offices in _____ (Address of Vendor), registered under the no. _____ of the Companies' register of _____ (Name of Place and Country), capital stock of _____ (Value), with a place of business in _____ (Name of Place and Country) (hereinafter referred to as "_____ (Name of Vendor)" which expression shall unless repugnant to the context shall include its successors & assigns.

AND

Bharat Heavy Electricals Ltd a company incorporated under the Indian Companies Act 1956 having its registered offices at BHEL House, Siri Fort, New Delhi -110 049 and having one of its works at Heavy Electrical Equipment Plant, Ranipur, Haridwar-249403 (Uttarakhand), India registered under the No. 4281 of 1964-65 of the companies register of Delhi, capital stock of Rs 4895.2 million with a place of registered office in New Delhi (hereinafter referred to as "BHEL") which expression shall unless repugnant to the context shall include its successors & assigns. hereinafter also referred to individually as "the Party" or collectively as "the Parties".

BACKGROUND

This Agreement sets forth the rights and obligations of the Parties with respect to the use, handling, protection and safeguarding of Proprietary Information that is disclosed by and between the Parties.

WHEREAS

A) the Parties wish to pursue exploratory discussions concerning a possible collaboration between them in relation to the Tender Enquiry No..... also mentioned in Exhibit 1;

B) It is anticipated that during the possible discussions it may be necessary for BHEL to share certain confidential and proprietary information in written, oral, visual and/or physical/sample/ form to the other party (collectively "**Proprietary Information**", more fully detailed in clause 1 herein below) for the purpose of enabling the parties to interact and deliberate the aforementioned order and take it further (hereinafter referred to as "**Purpose**")

The parties desire to protect such Proprietary Information and ensure that it is not disclosed to any third party without the permission of the party disclosing such Proprietary Information;

NOW, THEREFORE, the Parties have agreed as follows:

1. The term “Proprietary Information” shall mean any information or data of whatsoever kind of a confidential or proprietary nature disclosed by BHEL (hereinafter called the “Disclosing Party”) to the vendor) hereinafter called the “Receiving Party”), including but not limited to, commercial information, knowhow and technical information in the form of designs, drawings, concepts, requirements, specifications, trade secrets, IPR, brand name, marketing plans & all other non-public information, software, interfaces, components, processes, or the like, that have been or will be disclosed by the Disclosing Party to the Receiving Party pursuant to this Agreement, either in writing, orally or other form, which is designated as “Proprietary” or “Confidential” by the Disclosing Party by means of formal declaration or an appropriate stamp, legend or any other written or orally notice . Notwithstanding anything to the contrary contained hereinabove, all the drawings and other technical information shared regarding the above mentioned order by the Disclosing Party shall be considered Proprietary Information with or without being marked as confidential/proprietary at the time of sharing the same.

2. Proprietary Information may be conveyed, without limitation, through any written or printed documents, samples, models, electronic form on disk, tape, other storage media or any other means of disclosing such Proprietary Information that Disclosing Party may elect to use during the life of this Agreement, but if Disclosing Party originally discloses information orally or visually, the Receiving Party will protect such information as Proprietary Information to the extent that the Disclosing Party :

- identifies the Information as Proprietary at the time of original disclosure,
- summarizes the Proprietary Information in writing.

Information stored in electronic form on disk, tape, other storage media will be adequately marked if a proprietary legend displays when the information originally runs on a computer system and when the information is printed from its data file. Proprietary Information also includes any information which can be obtained by examination, testing or analysis of any hardware or material substance or any component part of such hardware or material substance provided by the Disclosing Party even though the requirements in Clause 1 for marking and designation have not been fulfilled.

3. The Disclosing Party, to the extent of its rights to do so, shall disclose to the other only the Proprietary Information which the Disclosing Party deems appropriate to fulfil the objectives of this Agreement. The Parties hereby represent that the disclosure of Proprietary Information by and between themselves shall be made in compliance with, and subject to the Indian laws and regulations.

4. The Receiving Party hereby agrees and covenants that, from the effective date of this Agreement until the expiry date as per article 11 and the following period as per article 12, the Proprietary Information that it receives from the Disclosing Party shall:

- a) be protected and kept in strict confidence by the Receiving Party which must use the same degree of care it uses to protect its own confidential information and in no case less than a reasonable care;
- b) be only disclosed to and used by those persons within the Receiving Party's organization who have a need to know and solely for the purposes specified in this Agreement, and be treated by such persons or entities with the same degree of care and subject to the same restrictions;
- c) to procure that each third party to whom Proprietary Information is disclosed under this Agreement is made aware of the provisions of this Agreement prior to such disclosure to it and that each such third party is bound by obligations of confidentiality which are no less onerous than those contained in this Agreement;
- d) neither be disclosed nor caused to be disclosed or made available, either directly or indirectly, to any third Party or persons other than those mentioned in subparagraph b) above or other persons upon which both of the contractual Parties shall agree in an amendment to this Agreement;
- e) not to reverse engineer, disassemble or decompile any prototypes, software or other tangible objects which embody the Proprietary Information and which are provided to the Receiving Party hereunder;
- f) not to copy, reproduce or reduce to writing any part of such Proprietary Information except as may be reasonably necessary for the purpose referred to in the Recitals of this Agreement

PROVIDED THAT the Receiving Party shall be entitled to make any disclosure required by court order or government or regulatory requirement of the Disclosing Party's Proprietary Information subject to notifying the Disclosing Party as soon as possible of such requirement.

5. Any Proprietary Information and copies thereof disclosed by the Disclosing Party to the other shall remain the property of the Disclosing Party and shall be immediately returned or destroyed by the Receiving Party upon request or upon expiry of this Agreement.

6. The Receiving Party shall have no obligations or restrictions with respect to any Proprietary Information for which the Receiving Party can prove that:

- a) is in or which comes into the public domain otherwise than as a result of a breach of this Agreement by any person to whom a disclosure of Proprietary Information is made as permitted under this Agreement or of any other duty of confidentiality relating to the Proprietary Information of which the Receiving Party has knowledge; or
- b) it has been in its possession without restriction at the time of the disclosure, as evidenced by written documentation in its files; or
- c) it has been lawfully received from a third Party without breach of this Agreement; or
- d) it has been or is published without violation of this Agreement; or
- e) disclosure of such proprietary information is required by Law or by a court of competent jurisdiction.

7. With respect to any exchange of Proprietary Information which may occur as a result of this Agreement, it is expressly understood and agreed that the persons listed in Exhibit 2 shall, on behalf of the respective Parties, be the exclusive individuals authorized to receive from and transmit to the other Party Proprietary Information under this Agreement. Each Party may replace at any time its respective authorized individuals identified in such Exhibit 2, within its own organization. Any such new designation by a Party shall be made by written notice to the other at the address indicated in such Exhibit 2.
8. Any Proprietary Information which is identified as "Classified Information", or whose export is subject to an export license, shall be identified as such by the Disclosing Party at the time of disclosure and the disclosure, protection, use and handling thereof, shall remain subject to the security procedures and restrictions imposed by the Disclosing Party's Government.
9. The disclosure of Proprietary Information under this Agreement by the Disclosing Party to the Receiving Party shall not be construed as granting to the Receiving Party any right, whether express or implied by licence or otherwise, on the matters, inventions or discoveries to which such information pertains, or as granting any trademark, patents, copyrights, trade secret right or other form of intellectual property right.
10. This Agreement covers the exchange of Proprietary Information which may be made by the Disclosing Party to the Receiving Party until ten years from signing of the agreement or any extension thereto which may be agreed upon by the Parties in writing. Proprietary information relevant to the Program detailed in Exhibit 1, already made available to the Receiving Party before the effective date, shall also be protected under this Agreement.

It is understood by the parties that, prior to disclosure, the Disclosing Party shall have obtained any government authorisation needed for the export of the Proprietary Information

11. The expiry of the period contemplated in Article 10 of this Agreement shall not relieve the Receiving Party from complying with the obligations imposed by Article 4 here above with respect to the use and protection of the Proprietary Information, received prior the date of such expiry, for a period of ten (10) years after such expiry.
12. The Parties are independent contractors. Each will bear all costs and expenses in connection with this Agreement. This Agreement is intended to facilitate only the exchange of Proprietary Information in connection with the contract entered between both the parties and is not intended to be, and shall not be construed to create a teaming agreement, joint venture, association, partnership, or other business organisation or agency arrangement and no Party shall have the authority to bind the other without the other Party's separate prior written agreement.

13. The Receiving Party shall indemnify the Disclosing Party for all costs, expenses or damages that Disclosing Party incurs as a result of any violation of any provisions of this Agreement. This obligation shall include court, litigation expenses, and actual, reasonable attorney's fees. The Receiving Party also agrees that monetary damages may be inadequate compensation to the Disclosing Party in the event the Receiving Party breaches any provision of this Agreement. Therefore, the parties agree that in the event of a breach or threatened breach of confidentiality, the Disclosing Party shall also be entitled to specific performance and injunctive or other equitable relief as a remedy for any such breach or anticipated breach.

14. This Agreement shall be governed by and shall be interpreted in accordance with the substantive Indian laws. Irrespective of the foregoing each Party shall remain bound by the provisions of its own national laws and regulations with respect to the transfer or use of Classified Information or information whose export is subject to an export license.

15. All disputes among the Parties, in connection with or arising out of the existence, validity, construction, performance and termination of this Agreement (or any terms thereof), which the Parties are unable to resolve among themselves, shall be finally settled by an Arbitration as per the Arbitration & Conciliation Act, 1996. The Arbitration shall be held in Haridwar (India), in English language, in accordance with the rules laid down in the Arbitration and Conciliation act of India 1996, of a sole arbitrator mutually appointed by both the parties. The courts of Haridwar shall have exclusive jurisdiction.

16. The foregoing constitutes the entire Agreement among the Parties with respect to the subject matter hereof and supersedes and cancels all prior representations, negotiations, commitments, undertakings, communications, either oral or written, acceptances, understandings and agreements among the Parties with respect to or in connection with any of the matters to which such Agreement applies or refers.

17. Notices to _____ (**Name of Vendor**) shall be made at the following address:

(Complete Address of Vendor)

Attention: Mr. _____ (**Name of the Authorised Person of Vendor**)

Notices to BHEL shall be made at the following address:

BHARAT HEAVY ELECTRICALS LIMITED,
HEAVY ELECTRICAL EQUIPMENT PLANT,
Ranipur, Haridwar-249403 (Uttarakhand), India]

Attention:

(Name of the PPX Incharge)

18. The effective date of this Agreement shall be the date of the last signature appearing herein.

IN WITNESS WHEREOF, each of the Parties has caused this Agreement, to be executed by its duly authorized officer.

Date :

Signed for and on behalf of
(Name of Vendor)

By:

Title:

Signature:

Signed for and on behalf of
BHEL

By:

Title:

Signature:

19. No failure or delay by either party in exercising or enforcing any right, remedy or power here under shall operate as a waiver hereof.

20. In the event that any provision of this Agreement shall be held by a court of competent jurisdiction to be unenforceable, the remaining portion hereof shall remain in full force & effect.

EXHIBIT 1

to the

NON-DISCLOSURE AGREEMENT

between

_____ **(Name of Vendor)** and
BHARAT HEAVY ELECTRICALS LIMITED

dated:

The Non Disclosure Agreement covers the exchange of Proprietary Information which may occur during the discussions and negotiations in view of a possible cooperation between the Parties in the following programs:

-Description of Material or Servicesfor which the Enquiry issued
/ Purchase order to be placed

_____ **(Name of Vendor)** list of products that require an exchange of Proprietary Information which may be occur during the discussions and negotiations in view of a possible cooperation for the above programs :

EXHIBIT 2

to the
NON-DISCLOSURE AGREEMENT
between
_____ (**Name of Vendor**) and
Bharat Heavy Electricals Ltd.

dated:

Personnel of the Parties authorized to receive and/or transmit Proprietary Information under this Agreement:

For (**Name of Vendor**)
(**Name of Person**)

Tel.

Fax

Address.

For Bharat Heavy Electricals Ltd.

Mr.

Tel. 01334

Fax 01334

Address. Main Administration Building
BHEL, HEEP, Haridwar
India

Mr.

Tel.

Tel. 01334

Fax

Fax 01334

Address.

Address. Main Administration Building
BHEL, HEEP, Haridwar
India

Clause on IP in the tender

Integrity Pact (IP)

- (a) IP is a tool to ensure that activities and transactions between the Company and its Bidders/ Contractors are handled in a fair, transparent and corruption free manner. Following Independent External Monitors (IEMs) on the present panel have been appointed by BHEL with the approval of CVC to oversee implementation of IP in BHEL.

SI	IEM	Email
1.	Shri Otem Dai, IAS (Retd.)	iem1@bhel.in
2.	Shri Bishwamitra Pandey, IRAS (Retd.)	iem2@bhel.in
3.	Shri Mukesh Mittal, IRS (Retd.)	iem3@bhel.in

- (b) The IP as enclosed with the tender is to be submitted (duly signed by authorized signatory) along with techno-commercial bid (Part-I, in case of two/ three part bid). Only those bidders who have entered into such an IP with BHEL would be competent to participate in the bidding. In other words, entering into this Pact would be a preliminary qualification.
- (c) Please refer Section-8 of IP for Role and Responsibilities of IEMs. In case of any complaint arising out of the tendering process, the matter may be referred to any of the above IEM(s). All correspondence with the IEMs shall be done through email only.

Note:

No routine correspondence shall be addressed to the IEM (phone/ post/ email) regarding the clarifications, time extensions or any other administrative queries, etc on the tender issued. All such clarification/ issues shall be addressed directly to the tender issuing (procurement) department's officials whose contact details are provided below:

Details of contact person(s):

(1)
Name: _____
Deptt: _____
Address: _____
Phone: (Landline/ Mobile) _____

Email: _____
Fax: _____

(2)
Name: _____
Deptt: _____
Address: _____
Phone: (Landline/ Mobile) _____

Email: _____
Fax: _____

INTEGRITY PACT**Between**

Bharat Heavy Electricals Ltd. (BHEL), a company registered under the Companies Act 1956 and having its registered office at "BHEL House", Siri Fort, New Delhi - 110049 (India) hereinafter referred to as "The Principal", which expression unless repugnant to the context or meaning hereof shall include its successors or assigns of the ONE PART

and

_____, (description of the party along with address), hereinafter referred to as "The Bidder/ Contractor" which expression unless repugnant to the context or meaning hereof shall include its successors or assigns of the OTHER PART

Preamble

The Principal intends to award, under laid-down organizational procedures, contract/s for _____

_____ (hereinafter referred to as "Contract"). The Principal values full compliance with all relevant laws of the land, rules and regulations, and the principles of economic use of resources, and of fairness and transparency in its relations with its Bidder(s)/ Contractor(s).

In order to achieve these goals, the Principal will appoint panel of Independent External Monitor(s) (IEMs), who will monitor the tender process and the execution of the contract for compliance with the principles mentioned above.

Section 1- Commitments of the Principal

- 1.1 The Principal commits itself to take all measures necessary to prevent corruption and to observe the following principles: -
 - 1.1.1 No employee of the Principal, personally or through family members, will in connection with the tender for, or the execution of a contract, demand, take a promise for or accept, for self or third person, any material or immaterial benefit which the person is not legally entitled to.
 - 1.1.2 The Principal will, during the tender process treat all Bidder(s) with equity and reason. The Principal will in particular, before and during the tender process, provide to all Bidder(s) the same information and will not provide to any Bidder(s) confidential/ additional information through which the Bidder(s) could obtain an advantage in relation to the tender process or the contract execution.
 - 1.1.3 The Principal will exclude from the process all known prejudiced persons.
- 1.2 If the Principal obtains information on the conduct of any of its employees which is a penal offence under the Indian Penal Code 1860 and Prevention of Corruption Act 1988 or any other statutory penal enactment, or if there be a substantive suspicion in this regard, the Principal will inform its Vigilance Office and in addition can initiate disciplinary actions.

Section 2 - Commitments of the Bidder(s)/ Contractor(s)

- 2.1 The Bidder(s)/ Contractor(s) commit himself to take all measures necessary to prevent corruption. The Bidder(s)/ Contractor(s) commits himself to observe the following principles during participation in the tender process and during the contract execution.

- 2.1.1 The Bidder(s)/ Contractor(s) will not, directly or through any other person or firm, offer, promise or give to the Principal or to any of the Principal's employees involved in the tender process or the execution of the contract or to any third person any material, immaterial or any other benefit which he/ she is not legally entitled to, in order to obtain in exchange any advantage of any kind whatsoever during the tender process or during the execution of the contract.
- 2.1.2 The Bidder(s)/ Contractor(s) will not enter with other Bidder(s) into any illegal or undisclosed agreement or understanding, whether formal or informal. This applies in particular to prices, specifications, certifications, subsidiary contracts, submission or non-submission of bids or any other actions to restrict competitiveness or to introduce cartelization in the bidding process.
- 2.1.3 The Bidder(s)/ Contractor(s) will not commit any penal offence under the relevant Indian Penal Code (IPC) and Prevention of Corruption Act; further the Bidder(s)/ Contractor(s) will not use improperly, for purposes of competition or personal gain, or pass on to others, any information or document provided by the Principal as part of the business relationship, regarding plans, technical proposals and business details, including information contained or transmitted electronically.
- 2.1.4 Foreign Bidder(s)/ Contractor(s) shall disclose the name and address of agents and representatives in India and Indian Bidder(s)/ Contractor(s) to disclose their foreign principals or associates. The Bidder(s)/ Contractor(s) will, when presenting his bid, disclose any and all payments he has made, and is committed to or intends to make to agents, brokers or any other intermediaries in connection with the award of the contract.
- 2.2 The Bidder(s)/ Contractor(s) will not instigate third persons to commit offences outlined above or be an accessory to such offences.
- 2.3 The Bidder(s)/ Contractor(s) shall not approach the Courts while representing the matters to IEMs and shall await their decision in the matter.

Section 3 - Disqualification from tender process and exclusion from future contracts

If the Bidder(s)/ Contractor(s), before award or during execution has committed a transgression through a violation of Section 2 above, or acts in any other manner such as to put his reliability or credibility in question, the Principal is entitled to disqualify the Bidder(s)/ Contractor(s) from the tender process, terminate the contract, if already awarded, exclude from future business dealings and/ or take action as per the separate "Guidelines on Banning of Business dealings with Suppliers/ Contractors", framed by the Principal.

Section 4 - Compensation for Damages

- 4.1 If the Principal has disqualified the Bidder (s) from the tender process before award / order acceptance according to Section 3, the Principal is entitled to demand and recover the damages equivalent to Earnest Money Deposit/ Bid Security.
- 4.2 If the Principal is entitled to terminate the Contract according to Section 3, or terminates the Contract in application of Section 3 above, the Bidder(s)/ Contractor (s) transgression through a violation of Section 2 above shall be construed breach of contract and the Principal shall be entitled to demand and recover from the Contractor an amount equal to 5% of the contract value or the amount equivalent to Security Deposit/ Performance Bank Guarantee, whichever is higher, as damages, in addition to and without prejudice to its right to demand and recover compensation for any other loss or damages specified elsewhere in the contract.

Section 5 - Previous Transgression

- 5.1 The Bidder declares that no previous transgressions occurred in the last 3 (three) years with any other company in any country conforming to the anti-corruption approach or with any other Public Sector Enterprise in India that could justify his exclusion from the tender process.
- 5.2 If the Bidder makes incorrect statement on this subject, he can be disqualified from the tender process or the contract, if already awarded, can be terminated for such reason or action can be taken as per the separate "Guidelines on Banning of Business dealings with Suppliers/ Contractors", framed by the Principal.

Section 6 - Equal treatment of all Bidder (s)/ Contractor (s) / Sub-contractor (s)

- 6.1 The Principal will enter into Integrity Pacts with identical conditions as this Integrity Pact with all Bidders and Contractors.
- 6.2 In case of Sub-contracting, the Principal Contractor shall take the responsibility of the adoption of Integrity Pact by the Sub-contractor(s) and ensure that all Sub-contractors also sign the Integrity Pact.
- 6.3 The Principal will disqualify from the tender process all Bidders who do not sign this Integrity Pact or violate its provisions.

Section 7 - Criminal Charges against violating Bidders/ Contractors /Subcontractors

If the Principal obtains knowledge of conduct of a Bidder, Contractor or Subcontractor, or of an employee or a representative or an associate of a Bidder, Contractor or Subcontractor which constitutes corruption, or if the Principal has substantive suspicion in this regard, the Principal will inform the Vigilance Office.

Section 8 -Independent External Monitor(s)

- 8.1 The Principal appoints competent and credible panel of Independent External Monitor (s) (IEMs) for this Integrity Pact. The task of the IEMs is to review independently and objectively, whether and to what extent the parties comply with the obligations under this Integrity Pact.
- 8.2 The IEMs are not subject to instructions by the representatives of the parties and performs his functions neutrally and independently. He reports to the CMD, BHEL.
- 8.3 The IEMs shall be provided access to all documents/ records pertaining to the Contract, for which a complaint or issue is raised before them as and when warranted. However, the documents/records/information having National Security implications and those documents which have been classified as Secret/Top Secret are not to be disclosed.
- 8.4 The Principal will provide to the IEMs sufficient information about all meetings among the parties related to the Contract provided such meetings could have an impact on the contractual relations between the Principal and the Contractor. The parties offer to the IEMs the option to participate in such meetings.

- 8.5 The advisory role of IEMs is envisaged as that of a friend, philosopher and guide. The advice of IEMs would not be legally binding and it is restricted to resolving issues raised by a Bidder regarding any aspect of the tender which allegedly restricts competition or bias towards some Bidders. At the same time, it must be understood that IEMs are not consultants to the Management. Their role is independent in nature and the advice once tendered would not be subject to review at the request of the organization.
- 8.6 For ensuring the desired transparency and objectivity in dealing with the complaints arising out of any tendering process or during execution of Contract, the matter should be examined by the full panel of IEMs jointly, who would look into the records, conduct an investigation, and submit their joint recommendations to the Management.
- 8.7 The IEMs would examine all complaints received by them and give their recommendations/ views to the CMD, BHEL at the earliest. They may also send their report directly to the CVO, in case of suspicion of serious irregularities requiring legal/ administrative action. Only in case of very serious issue having a specific, verifiable Vigilance angle, the matter should be reported directly to the Commission. IEMs will tender their advice on the complaints within 30 days.
- 8.8 The CMD, BHEL shall decide the compensation to be paid to the IEMs and its terms and conditions.
- 8.9 IEMs should examine the process integrity, they are not expected to concern themselves with fixing of responsibility of officers. Complaints alleging mala fide on the part of any officer of the Principal should be looked into by the CVO of the Principal.
- 8.10 If the IEMs have reported to the CMD, BHEL, a substantiated suspicion of an offence under relevant Indian Penal Code / Prevention of Corruption Act, and the CMD, BHEL has not, within reasonable time, taken visible action to proceed against such offence or reported it to the Vigilance Office, the IEMs may also transmit this information directly to the Central Vigilance Commissioner, Government of India.
- 8.11 After award of work, the IEMs shall look into any issue relating to execution of Contract, if specifically raised before them. As an illustrative example, if a Contractor who has been awarded the Contract, during the execution of Contract, raises issue of delayed payment etc. before the IEMs, the same shall be examined by the panel of IEMs. Issues like warranty/ guarantee etc. shall be outside the purview of IEMs.
- 8.12 However, the IEMs may suggest systemic improvements to the management of the Principal, if considered necessary, to bring about transparency, equity and fairness in the system of procurement.
- 8.13 The word 'Monitor' would include both singular and plural.

Section 9 - Pact Duration

- 9.1 This Integrity Pact shall be operative from the date this Integrity Pact is signed by both the parties till the final completion of contract for successful Bidder, and for all other Bidders 6 months after the Contract has been awarded. Any violation of the same would entail disqualification of the bidders and exclusion from future business dealings.
- 9.2 If any claim is made/ lodged during currency of this Integrity Pact, the same shall be binding and continue to be valid despite the lapse of this Pact as specified above, unless it is discharged/ determined by the CMD, BHEL.

Section 10 - Other Provisions

- 10.1 This Integrity Pact is subject to Indian Laws and exclusive jurisdiction shall be of the competent Courts as indicated in the Tender or Contract, as the case may be.
- 10.2 Changes and supplements as well as termination notices need to be made in writing.
- 10.3 If the Bidder(s)/ Contractor(s) is a partnership or a consortium or a joint venture, this Integrity Pact shall be signed by all partners of the partnership or joint venture or all consortium members.
- 10.4 Should one or several provisions of this Integrity Pact turn out to be invalid, the remainder of this Integrity Pact remains valid. In this case, the parties will strive to come to an agreement to their original intentions.
- 10.5 Only those bidders / contractors who have entered into this Integrity Pact with the Principal would be competent to participate in the bidding. In other words, entering into this Integrity Pact would be a preliminary qualification.
- 10.6 In the event of any dispute between the Principal and Bidder(s)/ Contractor(s) relating to the Contract, in case, both the parties are agreeable, they may try to settle dispute through Mediation before the panel of IEMs in a time bound manner. In case, the dispute remains unresolved even after mediation by the panel of IEMs, either party may take further action as the terms & conditions of the Contract. The fees/expenses on dispute resolution through mediation shall be shared by both the parties. Further, the mediation proceedings shall be confidential in nature and the parties shall keep confidential all matters relating to the mediation proceedings including any settlement agreement arrived at between the parties as outcome of mediation. Any views expressed, suggestions, admissions or proposals etc. made by either party in the course of mediation shall not be relied upon or introduced as evidence in any further arbitral or judicial proceedings, whether or not such proceedings relate to the dispute that is the subject of mediation proceedings. Neither of the parties shall present IEMs as witness in any Alternative Dispute Resolution or judicial proceedings in respect of the dispute that was subject of mediation.

 For & On behalf of the Principal
 (Office Seal)

 For & On behalf of the Bidder/ Contractor
 (Office Seal)

Place _____
 Date _____

Witness: _____
 (Name & Address) _____

Witness: _____
 (Name & Address) _____

No. P-45021/2/2017-PP (BE-II)
Government of India
Ministry of Commerce and Industry
Department for Promotion of Industry and Internal Trade
(Public Procurement Section)

Udyog Bhawan, New Delhi
Dated: 16th September, 2020

To

All Central Ministries/Departments/CPSUs/All concerned

ORDER

Subject: Public Procurement (Preference to Make in India), Order 2017– Revision; regarding.

Department for Promotion of Industry and Internal Trade, in partial modification [Paras 2, 3, 5, 10 & 13] of Order No.P-45021/2/2017-B.E.-II dated 15.6.2017 as amended by Order No.P-45021/2/2017-B.E.-II dated 28.05.2018, Order No.P-45021/2/2017-B.E.-II dated 29.05.2019 and Order No.P-45021/2/2017-B.E.-II dated 04.06.2020, hereby issues the revised 'Public Procurement (Preference to Make in India), Order 2017' dated 16.09.2020 effective with immediate effect.

Whereas it is the policy of the Government of India to encourage 'Make in India' and promote manufacturing and production of goods and services in India with a view to enhancing income and employment, and

Whereas procurement by the Government is substantial in amount and can contribute towards this policy objective, and

Whereas local content can be increased through partnerships, cooperation with local companies, establishing production units in India or Joint Ventures (JV) with Indian suppliers, increasing the participation of local employees in services and training them,

Now therefore the following Order is issued:

1. This Order is issued pursuant to Rule 153 (iii) of the General Financial Rules 2017.
2. **Definitions:** For the purposes of this Order:

'Local content' means the amount of value added in India which shall, unless otherwise prescribed by the Nodal Ministry, be the total value of the item procured (excluding net domestic indirect taxes) minus the value of imported content in the item (including all customs duties) as a proportion of the total value, in percent.

'Class-I local supplier' means a supplier or service provider, whose goods, services or works offered for procurement, meets the minimum local content as prescribed for 'Class-I local supplier' under this Order.

.....Contd. p/2

'Class-II local supplier' means a supplier or service provider, whose goods, services or works offered for procurement, meets the minimum local content as prescribed for 'Class-II local supplier' but less than that prescribed for 'Class-I local supplier' under this Order.

'Non - Local supplier' means a supplier or service provider, whose goods, services or works offered for procurement, has local content less than that prescribed for 'Class-II local supplier' under this Order.

'L1' means the lowest tender or lowest bid or the lowest quotation received in a tender, bidding process or other procurement solicitation as adjudged in the evaluation process as per the tender or other procurement solicitation.

'Margin of purchase preference' means the maximum extent to which the price quoted by a "Class-I local supplier" may be above the L1 for the purpose of purchase preference.

'Nodal Ministry' means the Ministry or Department identified pursuant to this order in respect of a particular item of goods or services or works.

'Procuring entity' means a Ministry or department or attached or subordinate office of, or autonomous body controlled by, the Government of India and includes Government companies as defined in the Companies Act.

'Works' means all works as per Rule 130 of GFR- 2017, and will also include 'turnkey works'.

3. Eligibility of 'Class-I local supplier'/ 'Class-II local supplier'/ 'Non-local suppliers' for different types of procurement

(a) In procurement of all goods, services or works in respect of which the Nodal Ministry / Department has communicated that there is sufficient local capacity and local competition, only 'Class-I local supplier', as defined under the Order, shall be eligible to bid irrespective of purchase value.

(b) Only 'Class-I local supplier' and 'Class-II local supplier', as defined under the Order, shall be eligible to bid in procurements undertaken by procuring entities, except when Global tender enquiry has been issued. In global tender enquiries, 'Non-local suppliers' shall also be eligible to bid along with 'Class-I local suppliers' and 'Class-II local suppliers'. In procurement of all goods, services or works, not covered by sub-para 3(a) above, and with estimated value of purchases less than Rs. 200 Crore, in accordance with Rule 161(iv) of GFR, 2017, Global tender enquiry shall not be issued except with the approval of competent authority as designated by Department of Expenditure.

(c) For the purpose of this Order, works includes Engineering, Procurement and Construction (EPC) contracts and services include System Integrator (SI) contracts.

3A. Purchase Preference

(a) Subject to the provisions of this Order and to any specific instructions issued by the Nodal Ministry or in pursuance of this Order, purchase preference shall be given to 'Class-I local supplier' in procurements undertaken by procuring entities in the manner specified here under.

(b) In the procurements of goods or works, which are covered by para 3(b) above and which are divisible in nature, the 'Class-I local supplier' shall get purchase preference over 'Class-II local supplier' as well as 'Non-local supplier', as per following procedure:

- i. Among all qualified bids, the lowest bid will be termed as L1. If L1 is 'Class-I local supplier', the contract for full quantity will be awarded to L1.
- ii. If L1 bid is not a 'Class-I local supplier', 50% of the order quantity shall be awarded to L1. Thereafter, the lowest bidder among the 'Class-I local supplier' will be invited to match the L1 price for the remaining 50% quantity subject to the Class-I local supplier's quoted price falling within the margin of purchase preference, and contract for that quantity shall be awarded to such 'Class-I local supplier' subject to matching the L1 price. In case such lowest eligible 'Class-I local supplier' fails to match the L1 price or accepts less than the offered quantity, the next higher 'Class-I local supplier' within the margin of purchase preference shall be invited to match the L1 price for remaining quantity and so on, and contract shall be awarded accordingly. In case some quantity is still left uncovered on Class-I local suppliers, then such balance quantity may also be ordered on the L1 bidder.

(c) In the procurements of goods or works, which are covered by para 3(b) above and which are not divisible in nature, and in procurement of services where the bid is evaluated on price alone, the 'Class-I local supplier' shall get purchase preference over 'Class-II local supplier' as well as 'Non-local supplier', as per following procedure:

- i. Among all qualified bids, the lowest bid will be termed as L1. If L1 is 'Class-I local supplier', the contract will be awarded to L1.
- ii. If L1 is not 'Class-I local supplier', the lowest bidder among the 'Class-I local supplier', will be invited to match the L1 price subject to Class-I local supplier's quoted price falling within the margin of purchase preference, and the contract shall be awarded to such 'Class-I local supplier' subject to matching the L1 price.
- iii. In case such lowest eligible 'Class-I local supplier' fails to match the L1 price, the 'Class-I local supplier' with the next higher bid within the margin of purchase preference shall be invited to match the L1 price and so on and contract shall be awarded accordingly. In case none of the 'Class-I local supplier' within the margin of purchase preference matches the L1 price, the contract may be awarded to the L1 bidder.

(d) "Class-II local supplier" will not get purchase preference in any procurement, undertaken by procuring entities.

3B. Applicability in tenders where contract is to be awarded to multiple bidders -

In tenders where contract is awarded to multiple bidders subject to matching of L1 rates or otherwise, the 'Class-I local supplier' shall get purchase preference over 'Class-II local supplier' as well as 'Non-local supplier', as per following procedure:

a) In case there is sufficient local capacity and competition for the item to be procured, as notified by the nodal Ministry, only Class I local suppliers shall be eligible to bid. As such, the multiple suppliers, who would be awarded the contract, should be all and only 'Class I Local suppliers'.

b) In other cases, 'Class II local suppliers' and 'Non local suppliers' may also participate in the bidding process along with 'Class I Local suppliers' as per provisions of this Order.

c) If 'Class I Local suppliers' qualify for award of contract for at least 50% of the tendered quantity in any tender, the contract may be awarded to all the qualified bidders as per award criteria stipulated in the bid documents. However, in case 'Class I Local suppliers' do not qualify for award of contract for at least 50% of the tendered quantity, purchase preference should be given to the 'Class I local supplier' over 'Class II local suppliers' / 'Non local suppliers' provided that their quoted rate falls within 20% margin of purchase preference of the highest quoted bidder considered for award of contract so as to ensure that the 'Class I Local suppliers' taken in totality are considered for award of contract for at least 50% of the tendered quantity.

d) First purchase preference has to be given to the lowest quoting 'Class-I local supplier', whose quoted rates fall within 20% margin of purchase preference, subject to its meeting the prescribed criteria for award of contract as also the constraint of maximum quantity that can be sourced from any single supplier. If the lowest quoting 'Class-I local supplier', does not qualify for purchase preference because of aforesaid constraints or does not accept the offered quantity, an opportunity may be given to next higher 'Class-I local supplier', falling within 20% margin of purchase preference, and so on.

e) To avoid any ambiguity during bid evaluation process, the procuring entities may stipulate its own tender specific criteria for award of contract amongst different bidders including the procedure for purchase preference to 'Class-I local supplier' within the broad policy guidelines stipulated in sub-paras above.

4. **Exemption of small purchases:** Notwithstanding anything contained in paragraph 3, procurements where the estimated value to be procured is less than Rs. 5 lakhs shall be exempt from this Order. However, it shall be ensured by procuring entities that procurement is not split for the purpose of avoiding the provisions of this Order.

5. **Minimum local content:** The 'local content' requirement to categorize a supplier as 'Class-I local supplier' is minimum 50%. For 'Class-II local supplier', the 'local content' requirement is minimum 20%. Nodal Ministry/ Department may prescribe only a higher

percentage of minimum local content requirement to categorize a supplier as 'Class-I local supplier'/ 'Class-II local supplier'. For the items, for which Nodal Ministry/ Department has not prescribed higher minimum local content notification under the Order, it shall be 50% and 20% for 'Class-I local supplier'/ 'Class-II local supplier' respectively.

6. **Margin of Purchase Preference:** The margin of purchase preference shall be 20%.
7. **Requirement for specification in advance:** The minimum local content, the margin of purchase preference and the procedure for preference to Make in India shall be specified in the notice inviting tenders or other form of procurement solicitation and shall not be varied during a particular procurement transaction.
8. **Government E-marketplace:** In respect of procurement through the Government E-marketplace (GeM) shall, as far as possible, specifically mark the items which meet the minimum local content while registering the item for display, and shall, wherever feasible, make provision for automated comparison with purchase preference and without purchase preference and for obtaining consent of the local supplier in those cases where purchase preference is to be exercised.
9. **Verification of local content:**
 - a. The 'Class-I local supplier'/ 'Class-II local supplier' at the time of tender, bidding or solicitation shall be required to indicate percentage of local content and provide self-certification that the item offered meets the local content requirement for 'Class-I local supplier'/ 'Class-II local supplier', as the case may be. They shall also give details of the location(s) at which the local value addition is made.
 - b. In cases of procurement for a value in excess of Rs. 10 crores, the 'Class-I local supplier'/ 'Class-II local supplier' shall be required to provide a certificate from the statutory auditor or cost auditor of the company (in the case of companies) or from a practicing cost accountant or practicing chartered accountant (in respect of suppliers other than companies) giving the percentage of local content.
 - c. Decisions on complaints relating to implementation of this Order shall be taken by the competent authority which is empowered to look into procurement-related complaints relating to the procuring entity.
 - d. Nodal Ministries may constitute committees with internal and external experts for independent verification of self-declarations and auditor's/ accountant's certificates on random basis and in the case of complaints.
 - e. Nodal Ministries and procuring entities may prescribe fees for such complaints.
 - f. False declarations will be in breach of the Code of Integrity under Rule 175(1)(i)(h) of the General Financial Rules for which a bidder or its successors can be debarred for up to two years as per Rule 151 (iii) of the General Financial Rules along with such other actions as may be permissible under law.

- g. A supplier who has been debarred by any procuring entity for violation of this Order shall not be eligible for preference under this Order for procurement by any other procuring entity for the duration of the debarment. The debarment for such other procuring entities shall take effect prospectively from the date on which it comes to the notice of other procurement entities, in the manner prescribed under paragraph 9h below.
- h. The Department of Expenditure shall issue suitable instructions for the effective and smooth operation of this process, so that:
 - i. The fact and duration of debarment for violation of this Order by any procuring entity are promptly brought to the notice of the Member-Convenor of the Standing Committee and the Department of Expenditure through the concerned Ministry /Department or in some other manner;
 - ii. on a periodical basis such cases are consolidated and a centralized list or decentralized lists of such suppliers with the period of debarment is maintained and displayed on website(s);
 - iii. in respect of procuring entities other than the one which has carried out the debarment, the debarment takes effect prospectively from the date of uploading on the website(s) in the such a manner that ongoing procurements are not disrupted.

10. Specifications in Tenders and other procurement solicitations:

- a. Every procuring entity shall ensure that the eligibility conditions in respect of previous experience fixed in any tender or solicitation do not require proof of supply in other countries or proof of exports.
- b. Procuring entities shall endeavour to see that eligibility conditions, including on matters like turnover, production capability and financial strength do not result in unreasonable exclusion of 'Class-I local supplier'/ 'Class-II local supplier' who would otherwise be eligible, beyond what is essential for ensuring quality or creditworthiness of the supplier.
- c. Procuring entities shall, within 2 months of the issue of this Order review all existing eligibility norms and conditions with reference to sub-paragraphs 'a' and 'b' above.

d. Reciprocity Clause

- i. When a Nodal Ministry/Department identifies that Indian suppliers of an item are not allowed to participate and/ or compete in procurement by any foreign government, due to restrictive tender conditions which have direct or indirect effect of barring Indian companies such as registration in the procuring country, execution of projects of specific value in the procuring country etc., it shall provide such details to all its procuring entities including CMDs/CEOs of PSEs/PSUs, State Governments and other procurement agencies under their administrative control and GeM for appropriate reciprocal action.

- ii. Entities of countries which have been identified by the nodal Ministry/Department as not allowing Indian companies to participate in their Government procurement for any item related to that nodal Ministry shall not be allowed to participate in Government procurement in India for all items related to that nodal Ministry/ Department, except for the list of items published by the Ministry/ Department permitting their participation.
 - iii. The stipulation in (ii) above shall be part of all tenders invited by the Central Government procuring entities stated in (i) above. All purchases on GeM shall also necessarily have the above provisions for items identified by nodal Ministry/ Department.
 - iv. State Governments should be encouraged to incorporate similar provisions in their respective tenders.
 - v. The term 'entity' of a country shall have the same meaning as under the FDI Policy of DPIIT as amended from time to time.
- e. Specifying foreign certifications/ unreasonable technical specifications/ brands/ models in the bid document is restrictive and discriminatory practice against local suppliers. If foreign certification is required to be stipulated because of non-availability of Indian Standards and/or for any other reason, the same shall be done only after written approval of Secretary of the Department concerned or any other Authority having been designated such power by the Secretary of the Department concerned.
- f. "All administrative Ministries/Departments whose procurement exceeds Rs. 1000 Crore per annum shall notify/ update their procurement projections every year, including those of the PSEs/PSUs, for the next 5 years on their respective website."

10A. Action for non-compliance of the Provisions of the Order: In case restrictive or discriminatory conditions against domestic suppliers are included in bid documents, an inquiry shall be conducted by the Administrative Department undertaking the procurement (including procurement by any entity under its administrative control) to fix responsibility for the same. Thereafter, appropriate action, administrative or otherwise, shall be taken against erring officials of procurement entities under relevant provisions. Intimation on all such actions shall be sent to the Standing Committee.

11. Assessment of supply base by Nodal Ministries: The Nodal Ministry shall keep in view the domestic manufacturing / supply base and assess the available capacity and the extent of local competition while identifying items and prescribing the higher minimum local content or the manner of its calculation, with a view to avoiding cost increase from the operation of this Order.

12. Increase in minimum local content: The Nodal Ministry may annually review the local content requirements with a view to increasing them, subject to availability of sufficient local competition with adequate quality.

13. **Manufacture under license/ technology collaboration agreements with phased indigenization:** While notifying the minimum local content, Nodal Ministries may make special provisions for exempting suppliers from meeting the stipulated local content if the product is being manufactured in India under a license from a foreign manufacturer who holds intellectual property rights and where there is a technology collaboration agreement / transfer of technology agreement for indigenous manufacture of a product developed abroad with clear phasing of increase in local content.
- 13A. In procurement of all goods, services or works in respect of which there is substantial quantity of public procurement and for which the nodal ministry has not notified that there is sufficient local capacity and local competition, the concerned nodal ministry shall notify an upper threshold value of procurement beyond which foreign companies shall enter into a joint venture with an Indian company to participate in the tender. Procuring entities, while procuring such items beyond the notified threshold value, shall prescribe in their respective tenders that foreign companies may enter into a joint venture with an Indian company to participate in the tender. The procuring Ministries/Departments shall also make special provisions for exempting such joint ventures from meeting the stipulated minimum local content requirement, which shall be increased in a phased manner.
14. **Powers to grant exemption and to reduce minimum local content:** The administrative Department undertaking the procurement (including procurement by any entity under its administrative control), with the approval of their Minister-in-charge, may by written order, for reasons to be recorded in writing,
- a. reduce the minimum local content below the prescribed level; or
 - b. reduce the margin of purchase preference below 20%; or
 - c. exempt any particular item or supplying entities from the operation of this Order or any part of the Order.

A copy of every such order shall be provided to the Standing Committee and concerned Nodal Ministry / Department. The Nodal Ministry / Department concerned will continue to have the power to vary its notification on Minimum Local Content.

15. **Directions to Government companies:** In respect of Government companies and other procuring entities not governed by the General Financial Rules, the administrative Ministry or Department shall issue policy directions requiring compliance with this Order.
16. **Standing Committee:** A standing committee is hereby constituted with the following membership:
- Secretary, Department for Promotion of Industry and Internal Trade—Chairman
 - Secretary, Commerce—Member
 - Secretary, Ministry of Electronics and Information Technology—Member
 - Joint Secretary (Public Procurement), Department of Expenditure—Member
 - Joint Secretary (DPIIT)—Member-Convenor

The Secretary of the Department concerned with a particular item shall be a member in respect of issues relating to such item. The Chairman of the Committee may co-opt technical experts as relevant to any issue or class of issues under its consideration.

17. Functions of the Standing Committee: The Standing Committee shall meet as often as necessary, but not less than once in six months. The Committee

- a. shall oversee the implementation of this order and issues arising therefrom, and make recommendations to Nodal Ministries and procuring entities.
- b. shall annually assess and periodically monitor compliance with this Order
- c. shall identify Nodal Ministries and the allocation of items among them for issue of notifications on minimum local content
- d. may require furnishing of details or returns regarding compliance with this Order and related matters
- e. may, during the annual review or otherwise, assess issues, if any, where it is felt that the manner of implementation of the order results in any restrictive practices, cartelization or increase in public expenditure and suggest remedial measures
- f. may examine cases covered by paragraph 13 above relating to manufacture under license/ technology transfer agreements with a view to satisfying itself that adequate mechanisms exist for enforcement of such agreements and for attaining the underlying objective of progressive indigenization
- g. may consider any other issue relating to this Order which may arise.

18. Removal of difficulties: Ministries /Departments and the Boards of Directors of Government companies may issue such clarifications and instructions as may be necessary for the removal of any difficulties arising in the implementation of this Order.

19. Ministries having existing policies: Where any Ministry or Department has its own policy for preference to local content approved by the Cabinet after 1st January 2015, such policies will prevail over the provisions of this Order. All other existing orders on preference to local content shall be reviewed by the Nodal Ministries and revised as needed to conform to this Order, within two months of the issue of this Order.

20. Transitional provision: This Order shall not apply to any tender or procurement for which notice inviting tender or other form of procurement solicitation has been issued before the issue of this Order.

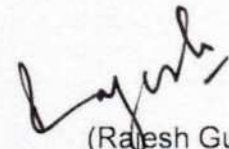

(Rajesh Gupta)
Director

Tel: 23063211

rajesh.gupta66@gov.in



BHARAT HEAVY ELECTRICALS LIMITED

HEEP-HARIDWAR, UTTARAKHAND (249403)

General Instructions and Standard Terms & Conditions for bidding against Tender Enquiry (GISTC)

For Indian Bidders (Version May-2024, Rev: 07)

Table of Contents

1. GENERAL.....	1
2. ORIGIN OF QUOTATION	1
3. SUBMISSION OF TENDER.....	1
4. TENDER OPENING.....	2
5. SPECIFICATION, DRAWINGS & STANDARD	2
6. PRICE SCHEDULE.....	3
7. REVERSE AUCTION.....	3
8. DELIVERY TERMS	3
9. LD FOR LATE DELIVERY	4
10. PAYMENT TERMS.....	4
11. TAXES & DUTIES.....	5
12. BANK GUARANTEE.....	6
13. GUARANTEE / WARRANTY AND CORRESPONDING REPAIRS / REPLACEMENT OF GOODS	6
14. QUALITY REQUIREMENT.....	6
15. VALIDITY	6
16. RIGHT OF ACCEPTANCE	6
17. TRANSIT INSURANCE	7
18. RISK PURCHASE	7
19. FORCE MAJEURE CLAUSE.....	7
20. NON-DISCLOSURE AGREEMENT	8
21. SETTLEMENT OF DISPUTES / ARBITRATION.....	8
22. WHARFAGE / DEMURRAGE RESPONSIBILITY.....	8
23. CONDITIONS FOR AVAILING MICRO & SMALL ENTERPRISES (MSE'S) BENEFITS	8
24. INFORMATION TO THE BIDDERS	10
25. MAKE IN INDIA (GOVT-NOTIFICATION)	10
26. RESTRICTIONS UNDER RULE 144(XI) OF THE GENERAL FINANCIAL RULES (GFRs), 2017	12
27. NOTE.	12

1. GENERAL.

These general terms & conditions shall apply to all the Tender Enquiries, notice inviting tenders, request for quotations concerning the supply of goods and / or rendering of services to Bharat Heavy Electricals Ltd., HEEP, Haridwar (hereinafter referred to as BHEL or the Purchaser). In case of placement of order these conditions will become part of Purchase Order (P.O) until unless the deviations are specifically agreed by BHEL.

2. ORIGIN OF QUOTATION.

A bidder shall not have conflict of interest with other bidders. Such conflict of interest can lead to anti-competitive practices to the detriment of Procuring Entity's interests. **The bidder found to have a conflict of interest shall be disqualified.** A bidder may be considered to have a conflict of interest with one or more parties in this bidding process, if:

- they have controlling partner (s) in common; **or**
- they receive or have received any direct or indirect subsidy/ financial stake from any of them; **or**
- they have the same legal representative/agent for purposes of this bid; **or**
- they have relationship with each other, directly or through common third parties, that puts them in a position to have access to information about or influence on the bid of another Bidder; **or**
- Bidder participates in more than one bid in this bidding process. Participation by a Bidder in more than one Bid will result in the disqualification of all bids in which the parties are involved. However, this does not limit the inclusion of the components/ sub-assembly/ Assemblies from one bidding manufacturer in more than one bid; **or**
- In cases of agents quoting in offshore procurements, on behalf of their principal manufacturers, one agent cannot represent two manufacturers or quote on their behalf in a particular tender enquiry. One manufacturer can also authorise only one agent/dealer. There can be only one bid from the following:
 - The principal manufacturer directly or through one Indian agent on his behalf; and
 - Indian/foreign agent on behalf of only one principal;**or**
- A Bidder or any of its affiliates participated as a consultant in the preparation of the design or technical specifications of the contract that is the subject of the Bid; **or**
- In case of a holding company having more than one independently manufacturing units, or more than one unit having common business ownership/management, only one unit should quote. Similar restrictions would apply to closely related sister companies. Bidders must proactively declare such sister/ common business/ management units in same/similar line of business. "

3. SUBMISSION OF TENDER.

- Bid / Quotation must be enclosed in sealed cover on which tender enquiry number and the due date MUST BE written and be invariably sent under REGISTERED POST / SPEED POST / COURIER / Dropped in the Tender Box: addressed as follows:

Quotation against Enquiry No. _____

Dated: _____

Due on: _____

To,

**THE HEAD OF MATERIALS MANAGEMENT,
Heavy Electrical Equipment Plant,
Bharat Heavy Electricals Limited,
HARIDWAR-249403 (Uttarakhand), INDIA.**

- TENDER ROOM is located at: Room No. - 415, 4th Floor, Main Admin. Building, BHEL-HEEP, Haridwar.



BHARAT HEAVY ELECTRICALS LIMITED

HEEP-HARIDWAR, UTTARAKHAND (249403)

General Instructions and Standard Terms & Conditions for bidding against Tender Enquiry (GISTC)

For Indian Bidders (Version May-2024, Rev: 07)

- c) In case of Three / Two Part Bid, technical bid containing technical offer, duly signed and un-priced copy of the Price Bid should be kept in one envelope. Price Bid containing only the price should be kept in a separate envelope. All envelopes indicating Part-1 or Part-2 or Part-3 as the case may be to be put in a bigger envelope. Please note that un-priced bid should be the exact replica of price bid but without prices.
- d) The bid / quotation must be posted before due date, keeping allowance for postal transit time. Quotations sent by any mode but not received in time will be ignored. Tender received through authorized E-mail is also acceptable. However, in time submission of tender in tender box shall be the responsibility of the bidder, sent through any mode. Documents submitted with the offer / bid shall be signed and stamped in each page by authorized representative of the bidder.
- e) Any additional documents submitted by supplier / bidder, during processing of registration application / tender or after placement of order shall not be accepted unless it is submitted with forwarding letter and duly signed and stamped.
- f) The bids of the bidders who are on the banned list and also the bids of the bidders, who engage the services of the banned firms, shall be rejected. The cutting / overwriting in the bid / offer must be duly attested by the signatories to the bid. The list of firms banned by BHEL is available on BHEL web site www.bhel.com.
- g) Being PMD vendor, if you are not quoting against this tender enquiry, please send your regret letter positively for our reference with valid reasons for not participating in the tender enquiry. Repeated lack of response on the part of bidder may lead to deletion such PMD vendor from BHEL's approved vendor list.
- h) The bidders will submit Integrity Pact, duly signed by its authorized signatory, along with their bids wherever estimated tender value is Rs. 2 Crore or more.
- i) In case of open tender, technically qualified unregistered bidders may apply online for registration through <http://www.bhel.com/index.php/vender>.
- j) BHEL reserves the right to award tendered quantities among more than one bidder (after acceptance of L1 price by the other bidders). BHEL can also consider awarding of part of the tendered quantity to other than L-1 bidder at L1 counter offered rates, if the quantity offered by the L-1 bidder is less than the quantity tendered for.
- k) In case of e-Tendering (Online bidding through e-portal), offline bid submitted in hard copy or in any other form by the vendor / supplier will not be accepted and will be rejected out rightly. Only e-portal bid will be accepted.

4. TENDER OPENING.

Tender opening is scheduled to start in the Tender Room at 2:00 PM, on the due date. Therefore, bid / quotations must reach this office / tender Box latest by 1:45 PM on due date. Only participating bidders are allowed to attend tender opening. **TENDERS RECEIVED AFTER THE SPECIFIED TIME OF THEIR 'SUBMISSION' WILL BE TREATED AS LATE TENDERS AND SHALL NOT BE CONSIDERED UNDER ANY CIRCUMSTANCES.** The bidders or their authorized representatives may be allowed to attend tender opening if duly authorized by their principals, through a tender specific letter on that particular day. General authorization letter is not acceptable.

Note: - Foreign bidders willing to attend the bid opening has to provide the requisite documents to the concerned Purchase executives for arranging gate pass for them.

5. SPECIFICATION, DRAWINGS & STANDARD.

- a) Bidders must give their detailed specification in the quotation along with relevant technical literature / catalogue etc. against the tender enquiry.
- b) The Bid should be accompanied with relevant copies of catalogues, drawings or specification as per tender enquiry.



BHARAT HEAVY ELECTRICALS LIMITED

HEEP-HARIDWAR, UTTARAKHAND (249403)

General Instructions and Standard Terms & Conditions for bidding against Tender Enquiry (GISTC)

For Indian Bidders (Version May-2024, Rev: 07)

If these documents are not furnished, the offer is liable to be rejected.

- c) Wherever national / international (N/IN) standards are referred, the latest N/IN standards are to be followed. Mention year & date of standard revision that shall be followed for the supply.
- d) All Drawings and Standards are proprietary of BHEL. It must not be used in anyway detrimental to the interest of BHEL or without permission of BHEL.

6. PRICE SCHEDULE.

- a) Kindly quote your prices in figures and words both. In case of any discrepancy in value, the prices quoted in words shall be considered for evaluation and establishing L1 status.
- b) Prices quoted should not be more than the prices quoted to any other BHEL units / offices / divisions. Vendor to submit copy of latest Purchase Order placed by any unit of BHEL for similar items in the technical bid. In case no order has been placed on such items, specific confirmation that no order has been placed on such items should be provided.
- c) Prices should be quoted on F.O.R. Destination basis. Transit insurance shall be arranged by BHEL and not to be included in the prices. The offers quoted on other than F.O.R destination basis may result in non-consideration of such bids.
- d) In case BHEL accepts the EX-Works prices, such offers will be loaded by 1.5% of EX-Works value towards freight or with actual freight charges as per BHEL freight rate contract whichever is higher.
- e) In case of Indigenous items covered by DGS & D Rate Contract, the bidders should submit latest valid copy of the rate contract along with bid / quotation
- f) Applicable **IGST / CGST / SGST** and any other statutory levy should be indicated separately and clearly in the bid / quotation.

- g) Bidders can dispatch goods through any Indian Bank Association approved transporters having their branch at HARIDWAR / destination. If material is dispatched through other than Indian Bank Association approved transporter, material to be delivered on door delivery BHEL Stores basis.
- h) In case of dispatch of material through any other unapproved transporter, payment shall be made only after receipt of material and any additional charges payable to the transporter shall be to the bidder's account.
- i) Any demurrage / godown rent payable to the transporter / or to godown's owner due to any delay attributed by the supplier shall be recovered from supplier's account.
- j) Currency of Evaluation shall be INR.

NB: Financial evaluation of L1, L2Status will be on the basis of Landed Cost to BHEL.

7. REVERSE AUCTION.

Wherever RA is declared in the special terms and conditions of tender enquiry, following shall be applicable and Bidders to confirm the same:

"BHEL shall be resorting to Reverse Auction (RA) (Guidelines as available on www.bhel.com) for this tender. RA shall be conducted among all the techno-commercially qualified bidders.

Price bids of all techno-commercially qualified bidders shall be opened and same shall be considered as initial bids of bidders in RA. In case any bidder(s) do(es) not participate in online Reverse Auction, their sealed envelope price bid along with applicable loading, if any, shall be considered for ranking."

8. DELIVERY TERMS.

- a) Goods shall be delivered on 'FOR Destination' basis to the named destination unless otherwise called for in the tender enquiry.
- b) Loading on account of 3rd party inspection charges in case of Indian bidders shall be 0.20%.



BHARAT HEAVY ELECTRICALS LIMITED

HEEP-HARIDWAR, UTTARAKHAND (249403)

General Instructions and Standard Terms & Conditions for bidding against Tender Enquiry (GISTC)

For Indian Bidders (Version May-2024, Rev: 07)

9. LIQUIDATED DAMAGES (LD) FOR LATE DELIVERY.

a) Where items of Purchase Order are independently usable.

Liquidated Damages (LD) for Late Deliveries shall be applicable @0.5% per week or part thereof on the value of respective delayed supplies subject to a maximum of 10% of the value of respective delayed supplies. Value of delayed supplies will mean the Gross Value payable to the vendor (Before LD) against such supplies excluding taxes and duties.

b) **Where the total items are required for a main equipment and items are interdependent.**

Liquidated Damages (LD) for Late Deliveries shall be applicable @0.5% per week or part thereof on total value of Purchase Order subject to maximum of 10% of the total value of Purchase Order. Purchase Order value for this purpose shall be the Total Gross Value payable to the vendor (Before LD) excluding taxes and duties.

c) Bidders are requested to quote the best delivery meeting the delivery requirements. BHEL reserves the right to reject the offers not meeting BHEL's delivery requirement.

d) Commencement of delivery period shall be reckoned from the date of PO / LOI or any other agreed milestone.

e) Bidder shall deliver the goods in the manner and schedule agreed under the terms and conditions of Purchase order.

f) **DELIVERY IN CASE OF REJECTION:** In case the material is rejected, then date of replacement will be considered as the actual date of delivery.

g) **DELIVERY AGAINST BANK DOCUMENTS:** In case payment terms quoted by bidder are documents through bank, and the delivery terms being "FOR Haridwar / FOR Transporter Go-down" then date of delivery will be date of intimation by transporter / bidder of delivery of material at Haridwar for the LD purpose.

h) Where the payments are through bank, the documents may be presented for negotiation to BHEL authorized / nominated bank.

i) Payment of Liquidated Damages (LD) shall not in any way relieve the vendor from any of its obligations & liabilities under the contract.

10. PAYMENT TERMS.

a) BHEL's standard payment term is Payment after receipt and acceptance of materials / items at HEEP, BHEL-Store or at desired destination unless otherwise specified in Special Terms attached to the tender enquiry.

b) BHEL reserves the right to accept or reject the offer of the bidder who quotes the payment term other than BHEL's standard payment term.

c) Loading on account of deviation in payment terms shall be done as per extant rules of BHEL-Haridwar.

d) 100% payment along with taxes, freight & insurance will be made after receipt and acceptance of material and within 75 days from the date of invoice subject to submission of non-discrepant documents within 15 days of supply as per terms and conditions of Purchase Order. In case any discrepancy found in the documents, BHEL will notify the same to vendor within 7 days of receipt. Vendor has to clear all the discrepancies in one go within 7 days thereafter else the payment of vendor may get delayed.

e) For MSEs (covered under MSME Act) which are registered and periodically renewed with BHEL, the payment will be made within 45 days or as prescribed in the relevant act.

f) Adherence to the above time schedule of payment is contingent upon Vendor complying with GST Rules w.r.t availment of Input Tax Credit by BHEL.

g) In case GST credit is delayed / denied to BHEL, due to non / delayed receipt of goods and / or tax invoice or expiry of the timeline prescribed in GST Law for availing such ITC, or any other reason not attributable to BHEL, GST amount shall be recoverable from Vendor along with interest levied / leviable on BHEL.

h) The taxes and duties that are reimbursed would be the ones applicable as on the contractual Purchase order delivery date or the amount actually paid whichever is less.



BHARAT HEAVY ELECTRICALS LIMITED

HEEP-HARIDWAR, UTTARAKHAND (249403)

General Instructions and Standard Terms & Conditions for bidding against Tender Enquiry (GISTC)

For Indian Bidders (Version May-2024, Rev: 07)

i) The loading criteria for the different payment terms shall be as under;

Payment Terms	Days of Loading
After Receipt & Acceptance of material within 75 days of supply.	No Loading
Against Delivery at BHEL-Stores Haridwar.	45
Against documents through bank (CAD):	45
Letter of Credit (LC)	120
Usance LC	No Loading if usance period is > 120 Days.
	Loading of days' difference i.e. difference between 120 days and usance period if the usance period is < 75 days.
Advance	Delivery Period + 120 Days - Advance Payment Days.

11. TAXES & DUTIES.

- a) The bidder to specify in their offer (part 1 bid) the category of their registration under GST like Registered, Unregistered and composite dealer.
- b) The provisional GST registration number of Bharat Heavy Electrical Ltd, Heavy Electricals Equipment Plant, Ranipur, Haridwar is "05AAACB4146P1ZL" with state Code as "05" and State Name as "Uttarakhand".
- c) Please quote our provisional GST registration number in all invoices raised for supply of goods and services under GST regime and also ensure filing of timely return and payment of tax and compliance of other applicable provisions on supplier under GST regime.
- d) No GST will be reimbursed to unregistered or composite dealer. In the event, any GST is quoted by composite dealer, the same shall be added to the cost of supply in evaluating the bid.
- e) Since, input credit of GST will be available to BHEL-Haridwar only after correct filing of return and payment of applicable GST by supplier, reimbursement of GST shall be made by

BHEL-Haridwar on matching of vendor inputs at GST portal, ensuring availability of input credit to BHEL Haridwar. Payment of GST will be made to vendor after matching of input credit and vendor to ensure submission of their invoices along with consent to accept payment of tax after such matching in all cases where bills are submitted directly to BHEL-Haridwar or through bank or under LC or through any other mode.

- f) In the event of any disallowance of input credit or applicability of interest or any other financial liability arises on BHEL-Haridwar due to any default of supplier under GST, such implication shall be to supplier's account.
- g) In the event of any change in the status of the vendor after the submission of the bid but before the supply, GST applicable at the time of supply or in the bid, based on the registration status of the vendor, whichever is lower shall be payable.
- h) Where ever applicable If PAN (Permanent Account Number) of the recipient is not available, income tax is deductible either at the normal rate or at the rate of 20 percent, whichever is higher as per Section 206AA of Indian Income Tax Act 1961.
- i) The bidder shall clearly indicate HSN (*Harmonised System Nomenclature*) / SAC (*Service Accounting Code*), its description and applicable rate of GST for each item in his techno-commercial bid.
- j) Statutory Variation in Taxes & duties as applicable at the time of supply shall be payable. However, in the event of no change in law but bidder quoting certain tax structure in bid document which is lower than the applicable one, such amount shall be the maximum amount of tax that can be claimed by bidder.
- k) **IMPORTED GOODS OFFERED BY INDIAN BIDDERS AGAINST DEALER INVOICE:** Wherever the material being offered is imported, the bidder must quote the prices inclusive of IGST. The rate and value of IGST as included in the price must be indicated separately. In case quantum of IGST is not mentioned by the bidder the same will not be considered for



BHARAT HEAVY ELECTRICALS LIMITED

HEEP-HARIDWAR, UTTARAKHAND (249403)

General Instructions and Standard Terms & Conditions for bidding against Tender Enquiry (GISTC)

For Indian Bidders (Version May-2024, Rev: 07)

evaluation. However, bidder will have to pass on the benefit of IGST to BHEL at the time supply.

- l) In case of directly dispatchable items to Customer's Site, BHEL-Haridwar will inform the GST registration number of the respective customer which must be mentioned on the vendor's invoice. Vendor to ensure availability of such information from BHEL-Haridwar before dispatch of any material. However, while filing GSTN-1, BHEL Haridwar GSTN number to be quoted.

Note: - Vendors must ensure compliance of all the applicable rules and procedure as envisaged in the GST Regime. Any loss to BHEL-Haridwar due to fault / non-compliance by the vendor will be to the vendor's account.

12. BANK GUARANTEE.

In case the bank guarantees are required to be deposited towards security deposit/performance guarantee or for any other purpose as per the terms of this tender enquiry, such bank guarantees of the requisite value in the denominated currency of the purchase order should be from one of the Indian branch of BHEL consortium banks and the bank guarantee should be in the proforma as prescribed by BHEL. The proforma of bank guarantee and the list of consortium banks are displayed at BHEL website www.bhelhwr.co.in. However, in case the bank guarantee is not from BHEL consortium banks, then the bidder has to get the bank guarantee confirmed from one of the Indian branch of BHEL consortium banks and the bank charges for such confirmation will be borne by the bidder.

13. GUARANTEE / WARRANTY AND CORRESPONDING REPAIRS / REPLACEMENT OF GOODS.

Goods shall comply with the specifications for material, workmanship and performance. Unless otherwise specified, the warranty shall be for a period of 18 months from the date of receipt. If the delivery is found non-compliant during the warranty period, leading to rejection, the Seller shall arrange free replacement / repair of goods, within one month from the date of intimation or any mutually agreed period. The rejected goods shall be taken away by the Seller at his cost and

replaced on Delivered Duty Paid (DDP) (FOR - BHEL Stores / designated destination basis) within such period. In the event of the Seller's failure to comply, Purchaser may take action as appropriate, including Repair / Replenish rejected goods & disposal of rejections, at the risk & cost of the Seller. In case the defects attributable to Seller are detected during processing of the goods at BHEL or at our subcontractor's works, the Seller shall be responsible for free replacement / repair of the goods as required by BHEL.

- b) **RETURN OF REJECTED MATERIAL FOR REPLACEMENT:** The bidder shall have to pay 5% incidental charges while taking back supplied material if it is found rejected on receipt. The rejected material shall be sent back only after receipt of replacement / submission of BG / refund of amount paid.

14. QUALITY REQUIREMENT.

Your bid / quotation should have specific confirmation regarding meeting all our quality requirements such as. (i) Test Certificate (TC), (ii) Guarantee Certificate (GC) / Warranty Certificate (WC), (iii) Quality Plan (QP) (if applicable); and (iv) Pre-Dispatch Inspection at your works (if applicable).

15. VALIDITY.

The quotation should be valid for a minimum period of 90 days effective from the date of opening of tender, unless otherwise specified in the tender enquiry.

16. RIGHT OF ACCEPTANCE.

- a) **BHARAT HEAVY ELECTRICALS LIMITED HARIDWAR** reserves the right to reject any or all the bids / quotations without assigning any reason thereof. BHEL also reserves the right to increase or decrease the tendered quantities. Bidders should be prepared to accept order for reduced quantity without any extra charges.
- b) Any discount / revised offer / bids submitted by a bidder on its own shall be considered, provided it is received on or before the due date and time of offer / bid submission (Part-1). Conditional discounts shall not be considered for evaluation of tenders.



BHARAT HEAVY ELECTRICALS LIMITED

HEEP-HARIDWAR, UTTARAKHAND (249403)

General Instructions and Standard Terms & Conditions for bidding against Tender Enquiry (GISTC)

For Indian Bidders (Version May-2024, Rev: 07)

- c) Unsolicited discounts / revised offers / bids given after Part-1 bid opening shall not be accepted. No change in price will be permitted within the validity period asked for in the tender enquiry.
- d) In case of changes in scope and / or technical specification and / or commercial terms & conditions having price implication, techno-commercially acceptable bidders shall be asked by BHEL to submit the impact of such changes on their price bids. In case a bidder opts to submit revised price bid instead of impact called for then the latest price bid shall prevail. However, in both situations, original price bid will be necessarily opened.
- e) The bidder whose bid is technically not accepted will be informed & EMD wherever submitted shall be returned after finalization of contract. EMD shall be forfeited in the event of bidder opting out after tender opening.
- f) BHEL reserves the right to short close the existing Purchase Order / Rate Contract / Work Order or any extension thereof at any stage.

17. TRANSIT INSURANCE.

- a) Transit Insurance will be covered by BHEL under its open Insurance Policy. Seller shall inform dispatch particulars (Purchase Order, RR /GR, Invoice value etc.) to "Finance department (Store bill Section), BHEL Ranipur, Haridwar (Uttarakhand-India) with value of consignment to the Purchaser within 07 days of dispatch for BHEL to arrange insurance coverage in its policy. Failure on the part of seller to inform dispatch particulars will make him liable to pay for any transit damages / losses suffered by the Purchaser.
- b) If Quoted Prices are inclusive of transit insurance, no weightage shall be given while evaluating the bids for Cost of Insurance, being in BHEL Scope.

18. RISK PURCHASE.

In case of abnormal delays (beyond the maximum late delivery period as per LD clause) in supplies / defective supplies or non-fulfillment of any other terms and conditions given in Purchase Order, BHEL may cancel the Purchase Order in full or part thereof, and may also make the purchase of such material from elsewhere / alternative source at the risk and cost of the supplier. BHEL will take all reasonable steps to get the material from alternate source at optimum cost. If bidder does not agree to the above Risk Purchase Clause, BHEL reserves the right to reject the offer. In case for compelling reasons BHEL accepts the offer without acceptance of this clause by the bidder and in the eventuality of Risk Purchase, appropriate action will be taken as per BHEL extant rules. This will be without prejudice to any other right of BHEL under the contract or under General Law.

19. FORCE MAJEURE CLAUSE.

Notwithstanding any other thing contained anywhere else in the contract or PO (Purchase Order), In case the discharge of obligation under the contract by either party is impeded or made unreasonably onerous, neither party shall be considered in breach of the contract to the extent that performance of their respective obligation is prevented by an event of Force Majeure that arises after the effective date (PO date).

In the above clause, Force Majeure means an event beyond the control of the parties to the contract which prevents a party from complying with any obligation of the contract including but not limited to:

- Act of God (Such as but not limited to earthquake, drought, tidal waves, floods etc.).
- War (whether war be declared or not), Hostilities Invasion, Act of foreign enemy etc.
- Rebellion, revolution, insurrection, civil war etc.
- Contamination of Radio Activity from any nuclear fuel or from any other nuclear waste or any other hazardous materials.
- Riots, commotions, strike unless restricted to the employees of supplier.
- Acts of terrorism.



BHARAT HEAVY ELECTRICALS LIMITED

HEEP-HARIDWAR, UTTARAKHAND (249403)

General Instructions and Standard Terms & Conditions for bidding against Tender Enquiry (GISTC)

For Indian Bidders (Version May-2024, Rev: 07)

- g) Other unforeseeable circumstances beyond the control of the parties and which the affected party cannot avoid even by using its best efforts.
- h) Cancellation of contract by customer.
- i) Change in law / government. Regulation making the performance impossible.
- j) Pandemic or Epidemic.

The party claiming to be affected by force majeure shall notify the other party in writing immediately without delay on the intervention and on the cessation of such circumstances.

Irrespective of any extension of time, if an event of force majeure occurs and its effect continues for more than 180 days the affected party shall have right to cancel the contract.

As soon as reasonably practicable following the date of commencement of a Force Majeure Event, and within a reasonable time following the date of termination of a Force Majeure Event, either Party invoking it shall submit to the other Party reasonable proof of the nature of the Force Majeure Event and of its effect upon the performance of the Party's obligations under this Agreement.

The party shall, and shall ensure that its Subcontractors shall, at all times take all reasonable steps within their respective powers and consistent with Good Operating Practices (but without incurring unreasonable additional costs) to:

- a) Prevent Force Majeure Events affecting the performance of the party's obligations under this Agreement.
- b) mitigate the effect of any Force Majeure Event and
- c) Comply with its obligations under this Agreement.

If the war like situation has developed in a country where a seller's works is located in this P.O. or there is political instability and Indian Embassy located in that country forbids or advises for not having any business dealing with the sellers located in such zone / region/ country, then BHEL reserves the right to cancel the order.

20. NON-DISCLOSURE AGREEMENT.

All Drawing and Technical Documents relating to the product or it's manufacture submitted by one party to the other, prior or

subsequent to the formation of contract, shall remain property of the submitting party. Drawing, technical documents or other technical information received by one party, shall not without the consent of the other party, be used for any other purpose than that, for which they were provided. Such technical information shall not without the consent of the submitting party, otherwise be used or copied, reproduced, transmitted or communicated to a third party. Patterns supplied by BHEL will remain BHEL's property which shall be returned by the bidder on demand to BHEL. Bidder shall in no way share or use such intellectual property of BHEL to promote his own business with others or to gain a commercial advantage. BHEL reserves the right to claim damages from the bidder, or take appropriate action as deemed fit against the bidder, for any infringement of the provisions contained herein as available under law or equity.

21. SETTLEMENT OF DISPUTES / ARBITRATION.

In case of any dispute arising out of as in connection with this contract, the same shall be referred to arbitration under Arbitration & Conciliation Act 1996 of a sole arbitrator who shall be appointed by mutual consent of the parties. The seat & venue of arbitration shall be Haridwar.

The proceedings shall be conducted in English. The Governing law of contract shall be the substantive law of India.

22. WHARFAGE / DEMURRAGE RESPONSIBILITY.

In the event of delay in receipt of documents by Manager (Stores-Shipping) BHEL-Haridwar and in case where dispatches are made through Unapproved Transporter the sole responsibility for wharfage / demurrage for such delay shall be that of supplier.

23. CONDITIONS FOR AVAILING MICRO & SMALL ENTERPRISES (MSE'S) BENEFITS.

- a) "MSE Suppliers can avail the intended benefits only if they submit along with the offer, attested copies of either EM II certificate having deemed validity (**five years** from the date of issue of acknowledgement in EM II) or valid NSIC certificate or EM II certificate along with attested copy of a CA certificate



BHARAT HEAVY ELECTRICALS LIMITED

HEEP-HARIDWAR, UTTARAKHAND (249403)

General Instructions and Standard Terms & Conditions for bidding against Tender Enquiry (GISTC)

For Indian Bidders (Version May-2024, Rev: 07)

(Format enclosed at annexure-1 where deemed validity of EM II certificate of five years has expired) applicable for the relevant financial year (latest audited). Date to be reckoned for determining the deemed validity will be the date of bid opening (Part 1 in case of two-part bid) or vendor has to give Udyog Adhar Memorandum (UAM). Non submission of such documents will lead to consideration of their bid at par with other bidders. No benefit shall be applicable for this enquiry if any deficiency in the above required documents is found or the requisite documents are not submitted before price bid opening. If the tender is to be submitted through e-procurement portal, then the above require document are to be uploaded on the portal. Documents should be notarized or attested by a Gazetted officer. **UAM need not required to be notarized or attested.**

b) Any new supplier will be eligible for registration with BHEL as MSE supplier provided at least any one of the following documents are submitted along with application for registration: -

1. Udyog Adhar Memorandum (UAM).
2. Valid National Small Industries Commission (NSIC) Certificate.
3. Entrepreneurs Memorandum part II (EM II) certificate (valid based on deemed validity of 5 years) or
4. EM II certificate along with attested copy of CA Certificate (as per prescribed format at annexure-A) applicable for the relevant financial year (latest audited), where the deemed validity of EM II is over.
5. However, credentials of all MSE suppliers will be verified before advancing the intended benefits.
6. MSE bidders claiming SC/ST status will have to submit SC/ST certificate of the Proprietor from competent authority. Attested (notarized or attested by Gazetted officer) copy to be submitted along with the offer.
7. In case techno-commercial accepted bidders include MSE source and their prices (based on landed cost – considering quoted prices) are within the price band of 15% w.r.t. L-1 bidder, then BHEL can offer **25%** of quantity of respective item (rounded off to nearest number) to MSE bidders at L-1 price and in case, more than one MSE bidder is in 15 % band and the same is accepted by more than one MSE bidders then **25%** quantities of respective items will be considered for ordering on proportionate basis amongst MSE bidders.
8. There will be minimum of **3%** reservation for women owned MSEs within the above mentioned 25% reservation.
9. The reservation for MSEs owned by SC/ST will be **6.25%** { 25% out of target of 25% - refer para 4 of Public Procurement Policy for the Micro and Small Enterprises(MSEs)}.
10. The definition of MSEs owned by Women Entrepreneurs is clarified as under:
 - a) In case of proprietary MSE, proprietor shall be Woman.
 - b) In case of partnership MSE, the Woman partners shall be holding at least 51% of share in the unit.
 - c) In case of Private Limited companies, at least 51% share shall be held by Women promoters.
11. The definition of MSEs owned by SC/ST is clarified as under:
 - a) In case of proprietary MSE, proprietor(s) shall be SC/ST.
 - b) In case of partnership MSE, the SC/ST partners shall be holding at least 51% of shares in the unit.
 - c) In case of Private Limited companies, at least 51% share shall be held by SC/ST promoters.
12. While distributing the **25%** quantity amongst MSE bidders the decimal points in quantity shall be ignored for all the bidders except the L-1 amongst MSE bidders. Balance quantity after allocating the quantity to other MSE bidders ignoring the quantities in decimal, shall be given to L-1 (amongst MSE) bidder. However, if there are more than one MSE bidder at the same price level than preference for additional quantities due to ignoring off the decimal (as mentioned above) shall be given to the bidder offering favorable terms to BHEL and if the conditions offered are also same then preference will be given to the bidder having high SPR rating.
13. In case there are more than one MSE bidders (with different landed cost to BHEL) within 15% price band of lowest bidder and quantity to be offered is 1 no. only, then preference shall be given to the MSE bidder with lowest landed cost.
14. In case there are more than one MSE bidders (with same landed cost to BHEL) within 15% price band of lowest bidder and quantity to be offered is 1 no. only, then preference shall be given first, based on the favorable terms in the bid and in case terms are also same, the bidder with high SPR rating shall be given preference.
15. If L1 bidder is MSE bidder, entire quantity will be given to such MSE bidder only.



BHARAT HEAVY ELECTRICALS LIMITED

HEEP-HARIDWAR, UTTARAKHAND (249403)

General Instructions and Standard Terms & Conditions for bidding against Tender Enquiry (GISTC)

For Indian Bidders (Version May-2024, Rev: 07)

16. Note: It may however be noted that MSE guidelines as on date (Date of Technical Bid Opening Part-1) shall prevail.

17. "As per the OM No. F.No. 1(2)(1)/2016-MA dtd. 09.02.2017 issued from the Office of Development Commissioner (Micro, Small & Medium Enterprises), "Traders and agents should not be allowed to avail the benefits extended under the PP Policy."

In view of this, it is clarified that benefits of MSE (such as EMD Waiver, Tender fee exemption, Price preference, Payment preference etc.) will be given only to those MSE Vendors who are manufacturers of offered items against the NIT. No MSE benefits shall be provided to Agents / Stockists / Dealers / Traders etc. for the items offered but not manufactured by themselves."

24. INFORMATION TO THE BIDDERS.

a) Purchase related information is available at our Business-to-Business (B2B) Portal available on our website <https://hwr.bhel.com>. The user ID & password can be obtained by sending a request to concerned purchase executives.

b) Intimate your change in mail address or communication address or changes, if any, by email to AGM (SDX/MM) giving your bidder Code.

c) Please resolve your rejections and unexecuted overdue purchase order immediately which are posted at our B2B Portal, which can be visited through our site <https://hwr.bhel.com>

d) Copy of this Tender Enquiry is being sent through the post.

e) The Bidder declares that they will not enter into any illegal or undisclosed agreement or understanding, whether formal or informal with other bidder(s). This applies in particular to prices, specifications, certifications, subsidiary contracts, submission or non-submission of bids or any other actions to restrict competitiveness or to introduce cartelization in the bidding process.

In case, the bidder is found having indulged in above activities, suitable action shall be taken by BHEL as per extant policies/guidelines.

f) Supplier must upload digitally signed e-Invoice on B2B portal for processing of Bills.

In other cases, inked signed hard copy of Invoice to be submitted for processing of Bills.

25. MAKE IN INDIA (GOVT-NOTIFICATION).

A. This tender enquiry shall be governed by notification no. P-45021/2/2017-PP (BE-II) dated 04.06.2020 of government of INDIA and subsequent circulars issued afterwards. Accordingly, the minimum local content, the margin of purchase preference and the procedure for preference to make in INDIA shall be adhered.

B. The margin of purchase preference shall be 20%.

- 'Class-I local Supplier' means a supplier or service provider, whose goods, services or works offered for procurement, has local content equal to or more than 50%, as defined under this order.
- 'Class-II local Supplier' means a supplier or service provider, whose goods, services or works offered for procurement, has local content more than 20% but less than 50%, as defined under this order.
- 'Non- local Supplier' means a supplier or service provider, whose goods, services or works offered for procurement, has local content less than or equal to 20%, as defined under this order.

C. Vendor to specifically confirm if they are Class-I or Class-II local supplier or not as per above mentioned notification.

Accordingly, the 'Class-I local supplier' / 'Class-II local Supplier' at the time of tender, bidding or solicitation shall be required to indicate percentage of local content and provide self-certification that the item offered meets the local content requirement for 'Class-I local supplier' / 'Class-II local Supplier', as the case may be. They shall also give details of the location(s) at which the local value addition is made.

D. In cases of Procurement for a Value in Excess of Rs. 10 Crores, the 'Class-I local supplier' / 'Class-II local Supplier' shall be required to provide a Certificate from the Statutory Auditor or Cost Auditor of the Company (in the case of companies) or from a practicing Cost Accountant or practicing Chartered Accountant (in respect of suppliers other than companies) giving the percentage of Local Content.



BHARAT HEAVY ELECTRICALS LIMITED

HEEP-HARIDWAR, UTTARAKHAND (249403)

General Instructions and Standard Terms & Conditions for bidding against Tender Enquiry (GISTC)

For Indian Bidders (Version May-2024, Rev: 07)

E. Requirement of Purchase Preference:

Purchase preference shall be given to 'Class-I local supplier' in procurements undertaken by procuring entities in the manner specified hereunder -

a. In the procurements of goods or works, which are covered by para 3(b) of mentioned Govt. circular and which are divisible in nature, the 'class-I local supplier' shall get purchase preference over 'Class-II supplier' as well as 'Non-local supplier', as per following procedure:

- i. Among All qualified bids, the lowest bid will be termed as L1. If L1 is 'Class-I local supplier', the contract for full quantity will be awarded to L1.
- ii. If L1 bid is not a 'Class-I local supplier', 50% of the order quantity shall be awarded to L1. Thereafter, the lowest bidder among the 'Class-I local supplier' will be invited to match the L1 price for the remaining 50% quantity subject to the class-I local supplier's quoted price falling within the margin of purchase preference, and contract for that quantity shall be awarded to such 'Class-I local supplier' subject to matching the L1 price. In case such lowest eligible 'Class-I local supplier' fails to match the L1 price or accepts less than the offered quantity, the next higher 'Class-I local supplier' within the margin of purchase preference shall be invited to match the L1 price for remaining quantity and so on, and contract shall be awarded accordingly. In case some quantity is still left uncovered on Class-I local supplier, then such balance quantity may also be ordered on the L1 bidder".

b. In the procurements of goods or works, which are covered by para 3(b) of mentioned Govt. circular and which are not divisible in nature, and in procurement of services where the bid is evaluated on price alone, the 'class-I local supplier' shall get purchase preference over 'Class-II supplier' as well as 'Non-local supplier', as per following procedure:

- i. Among all qualified bids, the lowest bid will be termed as L1. If L1 is 'Class-I local supplier', the contract will be awarded to L1.
- ii. If L1 is not 'Class-I local supplier', the lowest bidder among the 'Class-I local supplier', will be invited to match the L1 price subject to Class-I local supplier's quoted price falling

within the margin of purchase preference, and the contract shall be awarded to such 'Class-I local supplier' subject to matching the L1 price.

- iii. In case such lowest eligible 'Class-I local supplier', fails to match the L1 price, the 'Class-I local supplier' with the next higher bid within the margin of purchase preference shall be invited to match the L1 price and so on and contract shall be awarded accordingly. In case none of the 'Class-I local supplier' within the margin of purchase preference matches the L1 prices, the contract may be awarded to the L1 bidder.

c. 'Class-II local supplier' will not get purchase preference in any procurement, undertaken by procuring entities.

F. For this procurement, the local content to categorize a supplier as a Class-I local supplier/ Class-II local supplier/ Non-local supplier and purchase preference to Class-I local supplier, is as defined in Public Procurement (Preference to Make in India), Order 2017 dated 04.06.2020 issued by DPIIT. In case of subsequent orders issued by nodal ministry, changing the definition of local content for the items of the NIT, the same shall be applicable even if issued after issue of this NIT, but before opening of Part-II bids against this NIT.

G. Procurements where estimated value to be procured is less than Rs. 5 lakhs shall be exempted from GOI order No. P-45021/2/2017-PP (BE-II) dated 04.06.2020.

H. For procurement of Goods & Services which are divisible in nature, following shall be operated for **MSE bidders** under Public procurement Policy for the Micro and Small Enterprises (MSEs) Amendment Order, 2019, Ref. No. AA:SSP: MSE: Amndt, dtd. 30.11.2018, Circular No. 44 of 2018-19;-

a. If L1 bid is not from "Class-I local Supplier" and price quoted by MSE bidder falls within the margin of Purchase preference (L1+15% for MSEs), then 25 % of total order quantity of respective item (rounded off to nearest number) shall be awarded to MSE bidder, subject to MSE bidder matching the L1 Price. Out of Remaining 75% quantity, distribution shall be operated as per below sub-clause (2) –

b. If "Class- I Local Supplier" (Next to L1, other than MSE) quoted price falling within the Margin of Purchase Preference, and "Class-I local supplier" matches the L1 price,



BHARAT HEAVY ELECTRICALS LIMITED

HEEP-HARIDWAR, UTTARAKHAND (249403)

General Instructions and Standard Terms & Conditions for bidding against Tender Enquiry (GISTC)

For Indian Bidders (Version May-2024, Rev: 07)

then 50% of remaining Quantity (after allocation of 25% to MSE) i.e. 37.5% shall be awarded to local supplier and 37.5% shall be awarded to foreign bidder.

Note: L1 Price refers to lowest evaluated / landed cost to Company.

For Further details, please refer GOI order no. P-45021 / 2 / 2017 - PP (BE-II) dated 04.06.2020.

26. RESTRICTIONS UNDER RULE 144(XI) OF THE GENERAL FINANCIAL RULES (GFRs), 2017

All provisions of Order No. F.No.6/18/2019-PPD of Department of Expenditure (DoE) shall be applicable for this tender enquiry (Order copy is available at <https://doe.gov.in/procurement-policy-divisions>). Accordingly, any bidder from a country which shares a land border with India (except the countries to which the Govt. of India has extended lines of credit or in which the Govt. of India is engaged in development projects for which list is available at <https://www.mea.gov.in/>) will be eligible to bid in this tender only if the bidder is registered with the Competent Authority as specified in Annex I of the said Order of DoE.

Updated list of the countries to which lines of credit have been extended or in which development projects are undertaken are available on the Ministry of External affairs website (<https://www.mea.gov.in/>)

For the purpose of this order, definition of Bidder from a country which shares a land border with India shall be same as defined in the Annex III of the said order.

Registration with the competent authority as stipulated in the said order is responsibility of bidder. Bidder has to submit a certificate certifying following along with offer:

"I have read the clause regarding restrictions on procurement from a bidder of a country which shares a land border with India;

I certify that bidder (... Name of Bidder) is not from such a country or, if from such a country, has been registered with the Competent Authority. I hereby certify that bidder (.....Name of bidder) fulfils all requirements in this regard and is eligible to be considered"

If the bidder is from such country which shares a land border with India evidence of valid registration by the Competent Authority shall also be attached along with offer."

27. NOTE.

- a) Special conditions of enquiry, if enclosed by BHEL, will supersede the respective standard / general terms of enquiry.
- b) Any other Standard terms and Conditions of the bidder attached / referred against the tender enquiry will be treated as null and void ab initio.
- c) In order to protect the commercial interests of BHEL, it becomes necessary to take action against suppliers / contractors by way of suspension of business dealings, who either fail to perform or are in default without any reasonable cause, cause loss of business / money / reputation, indulged in malpractices, cheating, bribery, fraud or any other misconducts or formation of cartel so as to influence the bidding process or influence the price etc. Guidelines for Suspension of Business Dealings with Suppliers / Contractors shall prevail over which is available at BHEL website <http://www.bhel.com>
- d) The bidder along with its associate / collaborators / sub-contractors / sub-vendors / consultants / service providers shall strictly adhere to BHEL Fraud Prevention Policy displayed on BHEL website <http://www.bhel.com> and shall immediately bring to the notice of BHEL-Management about any fraud or suspected fraud as soon as it comes to their notice.
- e) "BHEL shall recover the amount of compensation paid to victim(s) by BHEL towards loss of life / permanent disability due to an accident which is attributable to the negligence of contractor, agency or firm or any of its employees as detailed below;
 1. **Victim:** Any person who suffers permanent disablement or dies in an accident as defined below.
 2. **Accident:** Any death or permanent disability resulting solely and directly from any unintended and unforeseen injurious



BHARAT HEAVY ELECTRICALS LIMITED

HEEP-HARIDWAR, UTTARAKHAND (249403)

General Instructions and Standard Terms & Conditions for bidding against Tender Enquiry (GISTC)

For Indian Bidders (Version May-2024, Rev: 07)

occurrence caused during the manufacturing / operation and works incidental thereto at BHEL factories/ **offices and precincts** thereof , project execution , erection and commissioning, services, repairs and maintenance, trouble shooting, serving , overhaul, renovation and retrofitting , trial operation, performance guarantee testing undertaken by the company or during any works / during working at BHEL Units/ Offices/ townships and premises/ project sites.

3. Compensation in respect of each of the victims:

- (i) In the event of death or **permanent disability** resulting from **Loss of both limbs**: Rs. 10,00,000/- (Rs. Ten Lakh).
- (ii) In the event of **other permanent disability**: Rs. 7,00,000/- (Rs. Seven Lakh).

4. Permanent Disablement: A disablement that is classified as a permanent total disablement under the proviso to Section 2(l) of the Employees Compensation Act, 1923.”

f) The bidder shall be in compliance with applicable laws, rules and regulations throughout the terms of the contract for conducting its business generally and to perform its obligations under this contract.

MODEL CONCILIATION CLAUSE FOR CONDUCTING CONCILIATION PROCEEDINGS UNDER THE BHEL CONCILIATION SCHEME, 2018

The Parties agree that if at any time (whether before, during or after the arbitral or judicial proceedings), any Disputes (which term shall mean and include any dispute, difference, question or disagreement arising in connection with construction, meaning, operation, effect, interpretation or breach of the agreement, contract or the Memorandum of Understanding (delete whichever is inapplicable), which the Parties are unable to settle mutually), arise inter-se the Parties, the same may, be referred by either party to Conciliation to be conducted through Independent Experts Committee to be appointed by competent authority of BHEL from the BHEL Panel of Conciliators.

Notes:

1. No serving or a retired employee of BHEL/Administrative Ministry of BHEL shall be included in the BHEL Panel of Conciliators.
2. Any other person(s) can be appointed as Conciliator(s) who is/are mutually agreeable to both the parties from outside the BHEL Panel of Conciliators.

The proceedings of Conciliation shall broadly be governed by Part-III of the Arbitration and Conciliation Act 1996 or any statutory modification thereof and as provided in Annexure----- to this GCC/Agreement/Contract/MoU etc. (strike off whichever is inapplicable).

The Annexure ----- together with it's Formats will be treated as if the same is part and parcel hereof and shall be as effectual as if set out herein in this GCC/Agreement/Contract/MoU etc., (strike off whichever is inapplicable).

The Purchaser/Contractor/Seller etc. (insert the description of the other party to the Agreement/Contract/MoU etc., - whichever is applicable) agrees that the Purchaser/Contractor/Seller etc. (insert the description of BHEL - whichever is applicable) may make any amendments or modifications to the provisions stipulated in the Annexure -----to this GCC/Agreement/Contract/MoU etc., (strike off whichever is inapplicable) from time to time and confirms that it shall be bound by such amended or modified provisions of the Annexure -----with effect from the date as intimated by BHEL to it.

Surinder

Tender Enquiry No. 2890/C/6410/2023/4312/T1 for VERTICAL CNC 5 AXIS MILLING MACHINE-01 No.



SCHEDULE OF TECHNICAL DEVIATION

Name of Bidder :-

Please fill here

The following are the deviations/ variations exception from the Specification:

SL. No.	CLAUSE NO. OF GENERAL TERMS AND CONDITION	STATEMENT OF DEVIATION/ VARIATIONS/EXCEPTIONS

In case, this schedule is not submitted, it will be presumed that the equipment/ material to be supplied under this contract is deemed to be In compliance with the General Terms and Conditions & Specifications

If there is NIL deviation, even then the format to be filled as **NIL DEVIATION**.

Note: Continuation Sheets of like size and format may be used as per the Bidder's Requirement and shall be annexed to this scheduled.

Place: -

Date: -

Tender Enquiry No. 2890/C/6410/2023/4312/T1 for VERTICAL CNC 5 AXIS MILLING MACHINE-01 No.



SCHEDULE OF COMMERCIAL DEVIATION

Name of Bidder :- **Please fill here**

The following are the deviations/ variations exception from the General Terms and Conditions:

SL. No.	CLAUSE NO. OF GENERAL TERMS AND CONDITION	STATEMENT OF DEVIATION

- In case, this schedule is not submitted, it will be presumed that the equipment/ material to be supplied under this contract is deemed to be in compliance with the General Terms and Conditions.
 - If there is NIL deviation, even then the format to be filled as **NIL DEVIATION**.
- Note: Continuation Sheets of like size and format may be used as per the Bidder's Requirement and shall be annexed to this scheduled.

Place: -

Date: -

COST OF WITHDRAWAL DEVIATION SHEET**SCHEDULE OF TECHNICAL AND COMMERCIAL DEVIATION****Tender Enquiry No. 2890/C/6410/2023/4312/T1 for VERTICAL CNC 5 AXIS MILLING MACHINE-01 No.****ITEM:- VERTICAL CNC 5 AXIS MILLING MACHINE-01 No.****NAME OF VENDOR:-**

SL NO	VOULME/ SECTION	PAGE NO.	CLAUSE NO.	TECHNICAL SPECIFICATIO N/ TENDER DOCUMENT	COMPLETE DESCRIPTIO N OF DEVIATION	COST OF WITHDRAWL OF DEVIATION IN RUPEES)	REFERENCE OF PRICE SCHEDULE ON WHICH COST OF WITHDRAWL OF DEVIATION IS APPLICABLE	NATURE OF COST OF WITHDRAWL OF DEVIATION (POSITIVE)
-------	--------------------	----------	---------------	--	---	--	--	--

TECHNICAL DEVIATIONS

COMMERCIAL DEVIATIONS

PARTICULARS OF BIDDERS/ AUTHORISED REPRESENTATIVE

NAME	DESIGNATIONS	SIGN & DATE
------	--------------	-------------

NOTES:

1. Cost of withdrawl of deviation will be applicable on the basic price (i.e. excluding taxes, duties & freight) only.
2. All the bidders have to list out all their Technical & Commercial Deviations (if any) in detail in the above format.

3. Any deviation not mentioned above and shown separately or found hidden in offer, will not be taken cognizance of.

4. Bidder shall submit duly filled unpriced copy of above format indicating "quoted" in "cost of withdrawal of deviation" column of the schedule above along with their Techno-commercial offer, wherever applicable. In the absence of same, such deviation(s) shall not be considered and offer shall be considered in total compliance to NIT.

5. Bidder shall furnish price copy of above format along with price bid.

6. The final decision of acceptance/ rejection of the deviations quoted by the bidder shall be at discretion of the Purchaser.

7. Bidders to note that any deviation (technical/commercial) not listed in above and asked after Part-I opening shall not be considered.

8. For deviations w.r.t. Credit Period, Liquidated damages, if a bidder chooses not to give any cost of withdrawal of deviation loading as per GISTC, will apply. For any other deviation mentioned in un-priced copy of this format submitted with Part-I bid but not mentioned in priced copy of this format submitted with Priced bid, the cost of withdrawal of deviation shall be taken as NIL.

9. Any deviation mentioned in priced copy of this format, but not mentioned in the un-priced copy, shall not be considered.

10. All techno-commercial terms and conditions of NIT shall be deemed to have been accepted by the bidder, other than those listed in unpriced copy of this format.

11. Cost of withdrawal is to be given separately for each deviation. In no event bidder should club cost of withdrawal of more than one deviation else cost of withdrawal of such deviations which have been clubbed together shall be considered as NIL.

12. In case nature of cost of withdrawal is not specified it shall be assumed as positive.

13. In case of discrepancy in the nature of impact (positive), positive will be considered for evaluation and negative for ordering.

BANK GUARANTEE FOR PERFORMANCE SECURITY

Bank Guarantee No:

Date:

To
NAME
& ADDRESSES OF THE BENEFICIARY

Dear Sirs,

In consideration of Bharat Heavy Electricals Limited (hereinafter referred to as the 'Employer' which expression shall unless repugnant to the context or meaning thereof, include its successors and permitted assigns) incorporated under the Companies Act, 1956 and having its registered office at _____¹ through its Unit at.....(name of the Unit) having awarded to (Name of the Vendor / Contractor / Supplier) with its registered office at _____² hereinafter referred to as the 'Vendor / Contractor / Supplier', which expression shall unless repugnant to the context or meaning thereof, include its successors and permitted assigns), a contract Ref No.....dated³ valued at Rs.....⁴ (Rupees -----)/FC.....(in words.....) for⁵ (hereinafter called the 'Contract') and the Vendor / Contractor / Supplier having agreed to provide a Contract Performance Bank Guarantee, equivalent to% (.... Percent) of the said value of the Contract to the Employer for the faithful performance of the Contract,

we,, (hereinafter referred to as the Bank), having registered/Head office at and inter alia a branch at being the Guarantor under this Guarantee, hereby, irrevocably and unconditionally undertake to forthwith and immediately pay to the Employer any sum or sums upto a maximum amount of Rs -- -----⁶ (Rupees -----) without any demur, immediately on first demand from the Employer and without any reservation, protest, and recourse and without the Employer needing to prove or demonstrate reasons for its such demand.

Any such demand made on the Bank shall be conclusive as regards the amount due and payable by the Bank under this guarantee. However, our liability under this guarantee shall be restricted to an amount not exceeding Rs. _____.

We undertake to pay to the Employer any money so demanded notwithstanding any dispute or disputes raised by the Vendor / Contractor / Supplier in any suit or proceeding pending before any Court or Tribunal, Arbitrator or any other authority, our liability under this present being absolute and unequivocal.

The payment so made by us under this Guarantee shall be a valid discharge of our liability for payment thereunder and the Vendor / Contractor / Supplier shall have no claim against us for making such payment.

We thebank further agree that the guarantee herein contained shall remain in full force and effect during the period that would be taken for the performance of the said Contract/satisfactory completion of the performance guarantee period as per the terms of the Contract and that it shall continue to be enforceable till

all the dues of the Employer under or by virtue of the said Contract have been fully paid and its claims satisfied or discharged.

WeBANK further agree with the Employer that the Employer shall have the fullest liberty without our consent and without affecting in any manner our obligations hereunder to vary any of the terms and conditions of the said Contract or to extend time of performance by the said Vendor / Contractor / Supplier from time to time or to postpone for any time or from time to time any of the powers exercisable by the Employer against the said Vendor / Contractor / Supplier and to forbear or enforce any of the terms and conditions relating to the said Contract and we shall not be relieved from our liability by reason of any such variation, or extension being granted to the said Vendor / Contractor / Supplier or for any forbearance, act or omission on the part of the Employer or any indulgence by the Employer to the said Vendor / Contractor / Supplier or by any such matter or thing whatsoever which under the law relating to sureties would but for this provision have effect of so relieving us.

The Bank also agrees that the Employer at its option shall be entitled to enforce this Guarantee against the Bank as a principal debtor, in the first instance without proceeding against the Vendor / Contractor / Supplier and notwithstanding any security or other guarantee that the Employer may have in relation to the Vendor / Contractor / Supplier 's liabilities.

This Guarantee shall remain in force upto and including.....⁷ and shall be extended from time to time for such period as may be desired by Employer.

This Guarantee shall not be determined or affected by liquidation or winding up, dissolution or change of constitution or insolvency of the Vendor / Contractor / Supplier but shall in all respects and for all purposes be binding and operative until payment of all money payable to the Employer in terms thereof.

Unless a demand or claim under this guarantee is made on us in writing on or before the⁸we shall be discharged from all liabilities under this guarantee thereafter.

We, BANK lastly undertake not to revoke this guarantee during its currency except with the previous consent of the Employer in writing.

Notwithstanding anything to the contrary contained hereinabove:

- a) The liability of the Bank under this Guarantee shall not exceed.....⁶
- b) This Guarantee shall be valid up to⁷
- c) Unless the Bank is served a written claim or demand on or before _____⁸ all rights under this guarantee shall be forfeited and the Bank shall be relieved and discharged from all liabilities under this guarantee irrespective of whether or not the original bank guarantee is returned to the Bank.

We, _____ Bank, have power to issue this Guarantee under law and the undersigned as a duly authorized person has full powers to sign this Guarantee on behalf of the Bank.

For and on behalf of
(Name of the Bank)

Dated.....

Place of Issue.....

¹ NAME AND ADDRESS OF EMPLOYER I.e Bharat Heavy Electricals Limited

² NAME AND ADDRESS OF THE VENDOR /CONTRACTOR / SUPPLIER.

³ DETAILS ABOUT THE NOTICE OF AWARD/CONTRACT REFERENCE

⁴ CONTRACT VALUE

⁵ PROJECT/SUPPLY DETAILS

⁶ BG AMOUNT IN FIGURES AND WORDS

⁷ VALIDITY DATE

⁸ DATE OF EXPIRY OF CLAIM PERIOD

Note:

1. Units are advised that expiry of claim period may be kept 3-6 months after validity date. It may be ensured that the same is in line with the agreement/ contract entered with the Vendor.
2. The BG should be on Non-Judicial Stamp paper/e-stamp paper of appropriate value as per Stamp Act prevailing in the State(s) where the BG is submitted or is to be acted upon or the rate prevailing in the State where the BG was executed, whichever is higher. The Stamp Paper/e-stamp paper shall be purchased in the name of Vendor/Contractor/Supplier /Bank issuing the guarantee.
3. In line with the GCC, SCC or contractual terms, Unit may carry out minor modifications in the Standard BG Formats. If required, such modifications may be carried out after taking up appropriately with the Unit/Region's Law Deptt.

4. In Case of Bank Guarantees submitted by Foreign Vendors-

- a. **From Nationalized/Public Sector / Private Sector/ Foreign Banks (BG issued by Branches in India)** can be accepted subject to the condition that the Bank Guarantee should be enforceable in the town/city or at nearest branch where the Unit is located i.e. Demand can be presented at the Branch located in the town/city or at nearest branch where the Unit is located.
- b. **From Foreign Banks (wherein Foreign Vendors intend to provide BG from local branch of the Vendor country's Bank)**
 - b.1 In such cases, in the Tender Enquiry/ Contract itself, it may be clearly specified that Bank Guarantee issued by **any of the Consortium Banks only** will be accepted by BHEL. As such, Foreign Vendor needs to make necessary arrangements for issuance of Counter- Guarantee by Foreign Bank in favour of the Indian Bank's (BHEL's Consortium Bank) branch in India. It is advisable that all charges for issuance of Bank Guarantee/ counter- Guarantee should be borne by the Foreign Vendor. The tender stipulation should clearly specify these requirements.
 - b.2 **In case, Foreign Vendors intend to provide BG from Overseas Branch** of our Consortium Bank (e.g. if a BG is to be issued by SBI Frankfurt), the same is acceptable. However, the procedure at **sl.no. b.1** will required to be followed.
 - b.3 The BG issued may preferably be subject to Uniform Rules for Demand Guarantees (URDG) 758 (as amended from time to time). The BG Format provided to them should clearly specify the same.