

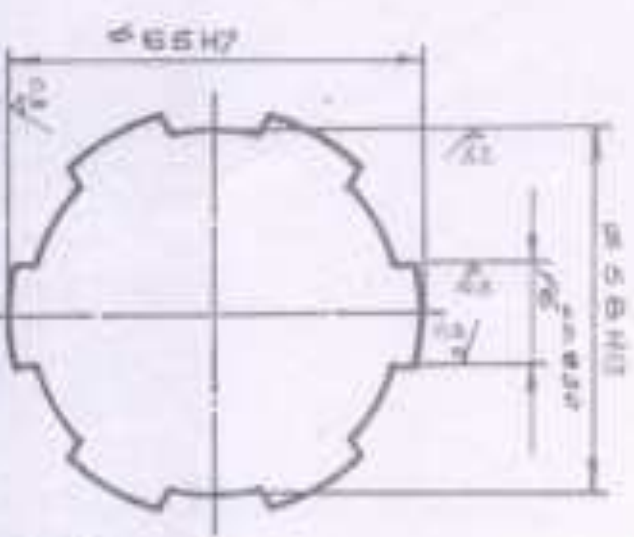



NUMBER	1
NO. OF TEETH	21
APPROXIMATE SHAPE	20°
LEADER OR COMPANY	30-25
CITY, STATE	INDIANAPOLIS, INDIANA
CORRECTION	+ 0.5°
ISSUED PART NO.	381222M
	(31-41)



SAFETY OF PARTS, SHIP  
 DESIGN OF PARTS

SW.  
 OO

\* CASE CARBONIZING TO A DEPTH OF 0.8 MM. THREE HOURS AFTER HEATING TO  
 RE INDOUSTRIAL HARDENED TO HRC 58-62.  
 \* BLUNT ALL SHARP CORNERS.  
 \* TEETH ARE TO BE KEELLESS.

CODES: - PART NO. -

DRANK JUNGHE YOUNG, SM	DEL V BORING M/C	381222M	46
CHD VIKRAM SHARMA	<b>GEAR</b>	1 M5671-0P-4G	
AEZ SINGHANI	<b>SPEED BOX</b>		
FE AKGEM DUTTA			
R. EX			
APP			



Spil

73-4-042 / 34

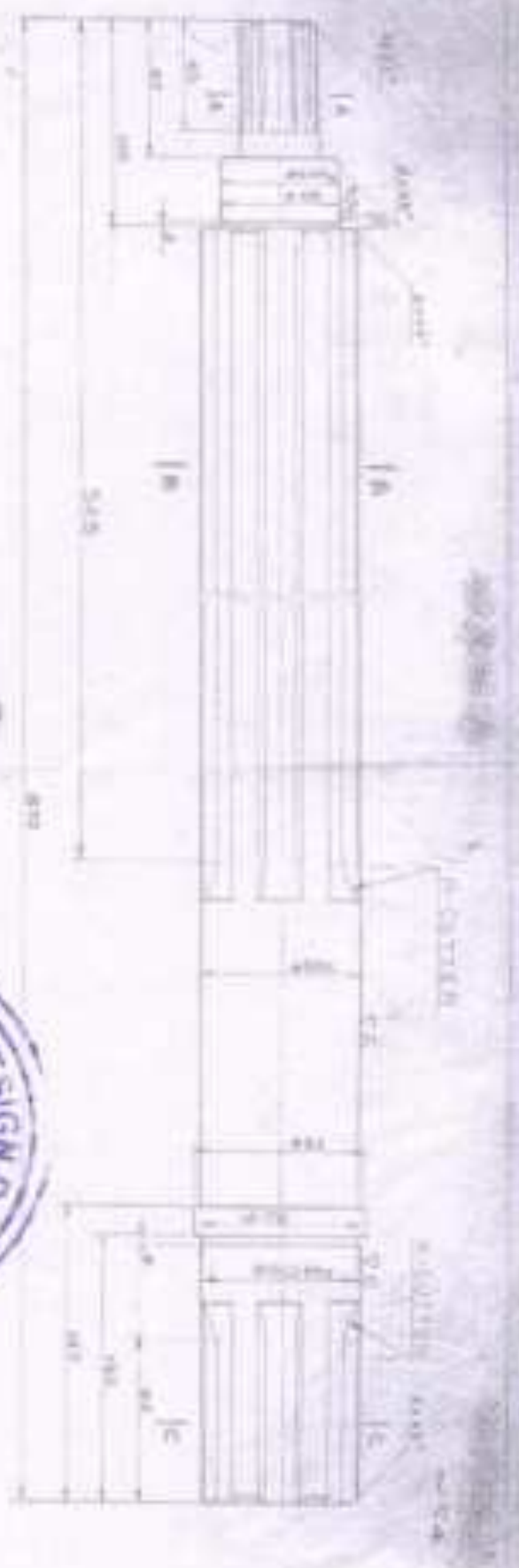

*Stamp*



NO.	DESCRIPTION	QTY	UNIT	REMARKS
1	SHAFT	1	PC	
2	GEAR	1	PC	
3	BEARING	2	PC	
4	KEY	1	PC	
5	WASHER	1	PC	
6	NUT	1	PC	
7	SCREW	1	PC	
8	SPACER	1	PC	
9	SEAL	1	PC	
10	BRACKET	1	PC	
11	PLATE	1	PC	
12	WASHER	1	PC	
13	NUT	1	PC	
14	SCREW	1	PC	
15	SPACER	1	PC	
16	SEAL	1	PC	
17	BRACKET	1	PC	
18	PLATE	1	PC	
19	WASHER	1	PC	
20	NUT	1	PC	
21	SCREW	1	PC	
22	SPACER	1	PC	
23	SEAL	1	PC	
24	BRACKET	1	PC	
25	PLATE	1	PC	
26	WASHER	1	PC	
27	NUT	1	PC	
28	SCREW	1	PC	
29	SPACER	1	PC	
30	SEAL	1	PC	
31	BRACKET	1	PC	
32	PLATE	1	PC	
33	WASHER	1	PC	
34	NUT	1	PC	
35	SCREW	1	PC	
36	SPACER	1	PC	
37	SEAL	1	PC	
38	BRACKET	1	PC	
39	PLATE	1	PC	
40	WASHER	1	PC	
41	NUT	1	PC	
42	SCREW	1	PC	
43	SPACER	1	PC	
44	SEAL	1	PC	
45	BRACKET	1	PC	
46	PLATE	1	PC	
47	WASHER	1	PC	
48	NUT	1	PC	
49	SCREW	1	PC	
50	SPACER	1	PC	
51	SEAL	1	PC	
52	BRACKET	1	PC	
53	PLATE	1	PC	
54	WASHER	1	PC	
55	NUT	1	PC	
56	SCREW	1	PC	
57	SPACER	1	PC	
58	SEAL	1	PC	
59	BRACKET	1	PC	
60	PLATE	1	PC	
61	WASHER	1	PC	
62	NUT	1	PC	
63	SCREW	1	PC	
64	SPACER	1	PC	
65	SEAL	1	PC	
66	BRACKET	1	PC	
67	PLATE	1	PC	
68	WASHER	1	PC	
69	NUT	1	PC	
70	SCREW	1	PC	
71	SPACER	1	PC	
72	SEAL	1	PC	
73	BRACKET	1	PC	
74	PLATE	1	PC	
75	WASHER	1	PC	
76	NUT	1	PC	
77	SCREW	1	PC	
78	SPACER	1	PC	
79	SEAL	1	PC	
80	BRACKET	1	PC	
81	PLATE	1	PC	
82	WASHER	1	PC	
83	NUT	1	PC	
84	SCREW	1	PC	
85	SPACER	1	PC	
86	SEAL	1	PC	
87	BRACKET	1	PC	
88	PLATE	1	PC	
89	WASHER	1	PC	
90	NUT	1	PC	
91	SCREW	1	PC	
92	SPACER	1	PC	
93	SEAL	1	PC	
94	BRACKET	1	PC	
95	PLATE	1	PC	
96	WASHER	1	PC	
97	NUT	1	PC	
98	SCREW	1	PC	
99	SPACER	1	PC	
100	SEAL	1	PC	











1. HATCHING TO THE PARTS.  
 2. HATCHING OF P.S.S. OR A.S.T. WITH RESPECT TO  $\phi 40$  SHOULD NOT EXCEED 0-02 MM.

*SP*

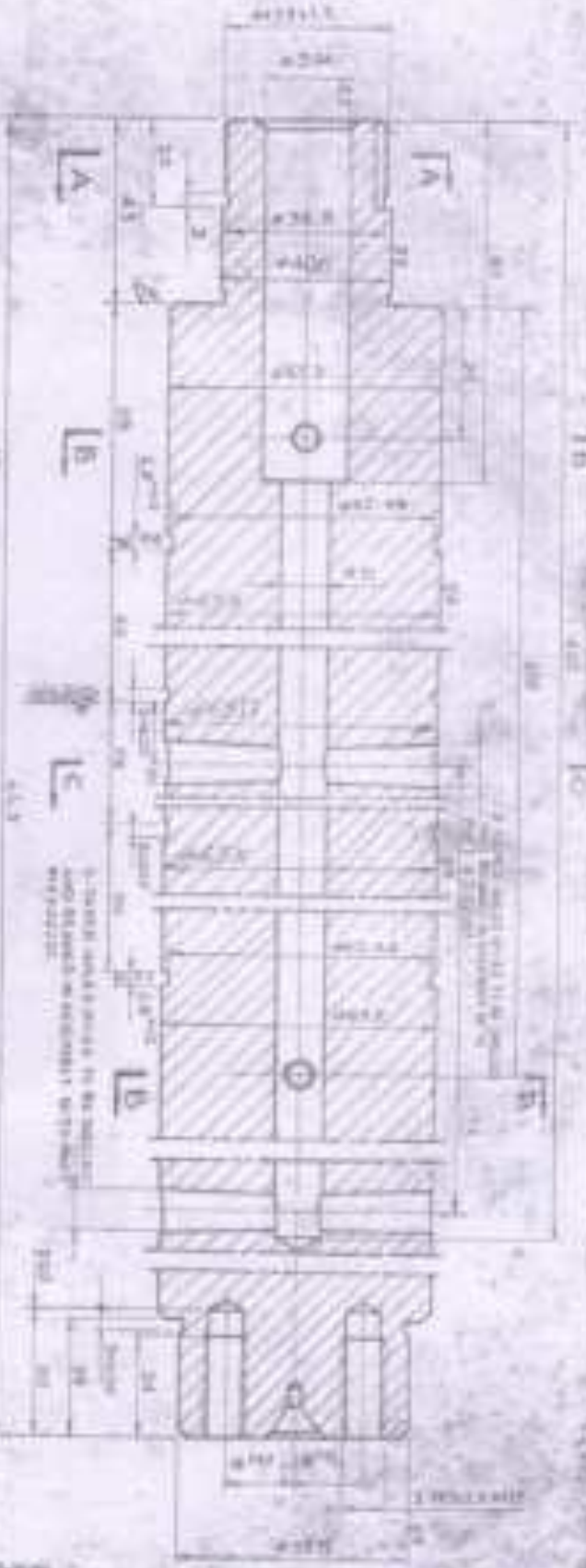
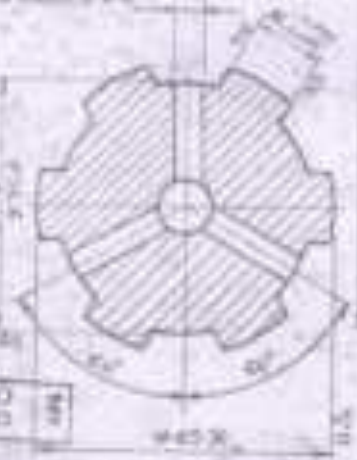
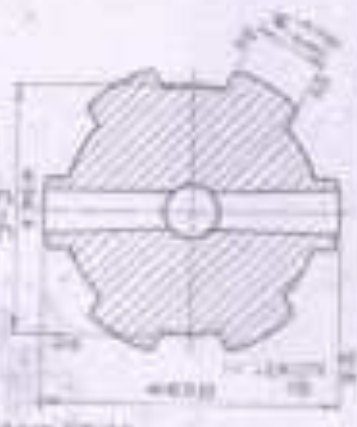

NO.	REVISION	DATE	BY	CHKD.
1	ISSUED FOR MANUFACTURING	15/08/22	WEX	WEX

SHEET NO. 2  
 PART NO. 2  
 WEX









CHD-PC-155/65541

CHUBBESS

MODULE	5
CALCULATION MODULE	675
NO OF TEETH	18
SPUR ANGLE	20°
DRIVEN ANGLE	30°
DRIVEN OF GEAR	R.H
NATURE PART ORN. NO.	68-114

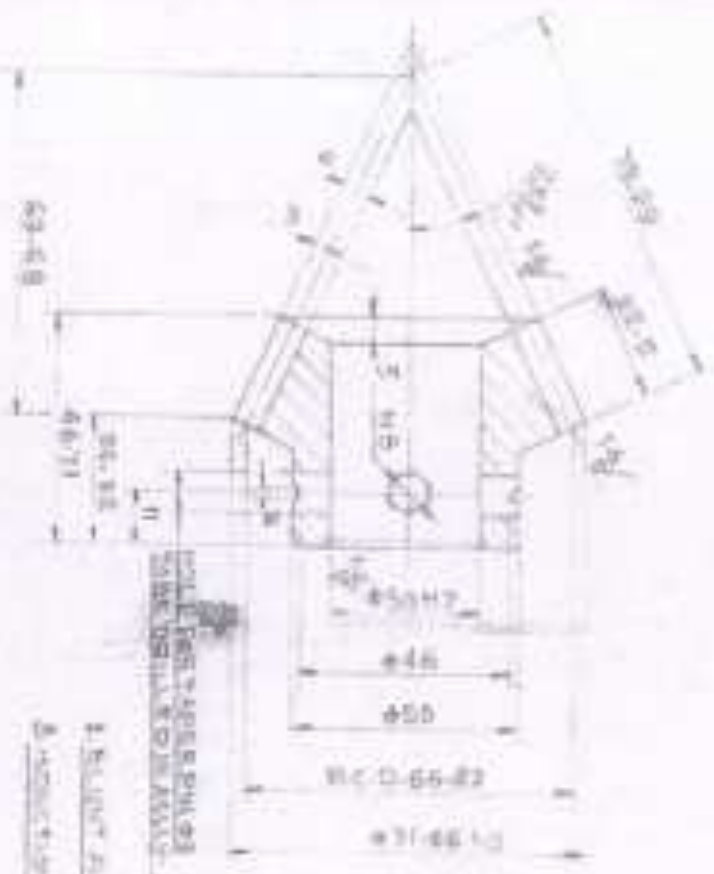

1. SELECT ALL SHED COMPANY  
 2. ADDITIONAL DIMENSIONS OF TEETH TO BE 20.00



DATE	7 AUG 2022
TIME	11:11
BY	...
FOR	...
PROJECT NO.	...
DESCRIPTION	...
DATE	...
BY	...
FOR	...
PROJECT NO.	...
DESCRIPTION	...
DATE	...
BY	...
FOR	...

*Handwritten signature*











STANDARD ALL INDIA CONNECTIONS

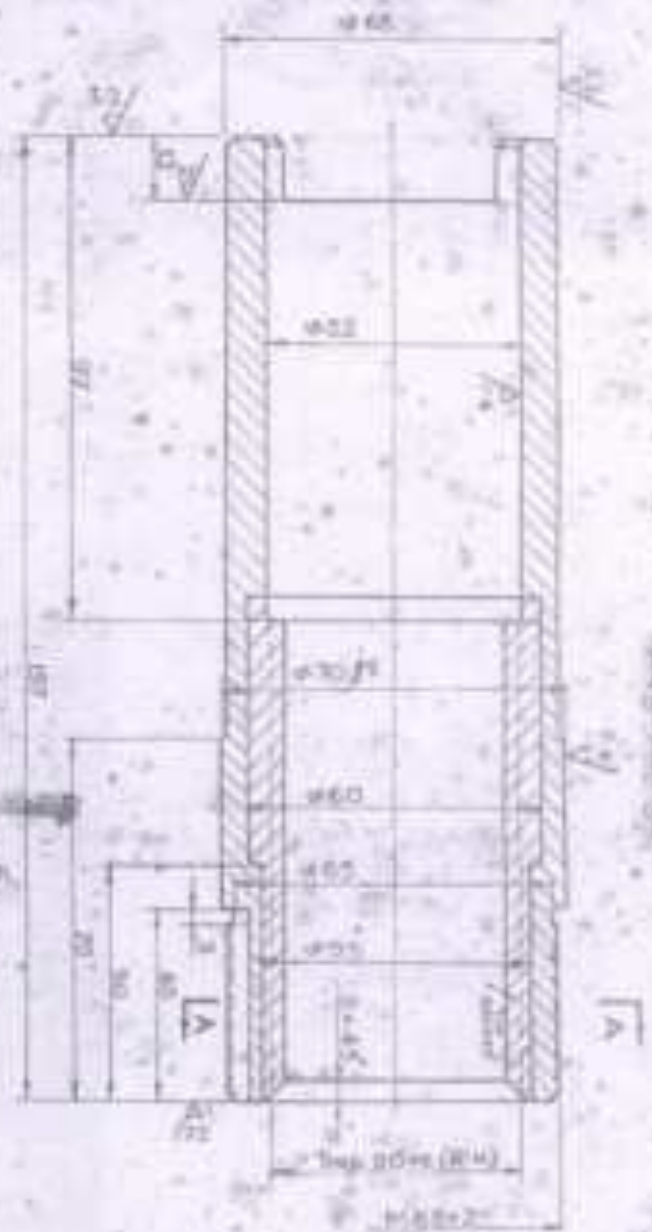

THREADED PIPE  
SCALE - 2:1

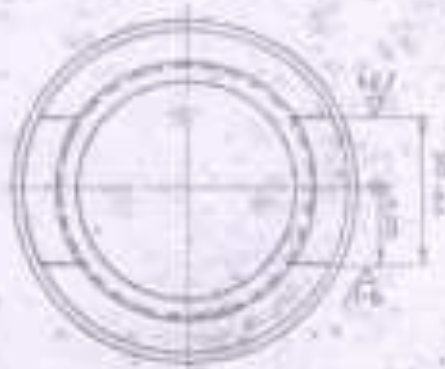
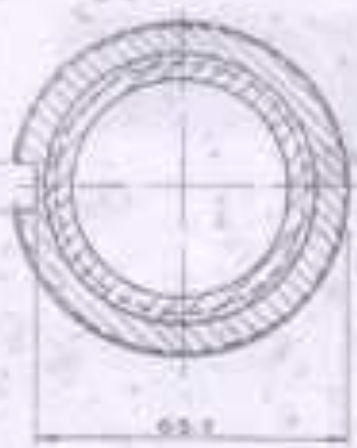

DRAWING NO.		PART NO.	
DESCRIPTION		ITEM NO.	
D.C.V. BOTTOM NUT		1	
LEPPER V. NUT		2	
(A. 100)		(A. 100)	
MATERIAL		GRADE	
MS		MS	
QUANTITY		REMARKS	
1		1	
DATE		BY	
11/1/07		JEP	
CHECKED		DATE	
11/1/07		11/1/07	

*Handwritten signature*

1/1/07



TAPEL 101.1 a JOINT DIST. 2018-10  
TO BE OBTAINED AND ASSEMBLED  
IN ASSEMBLY

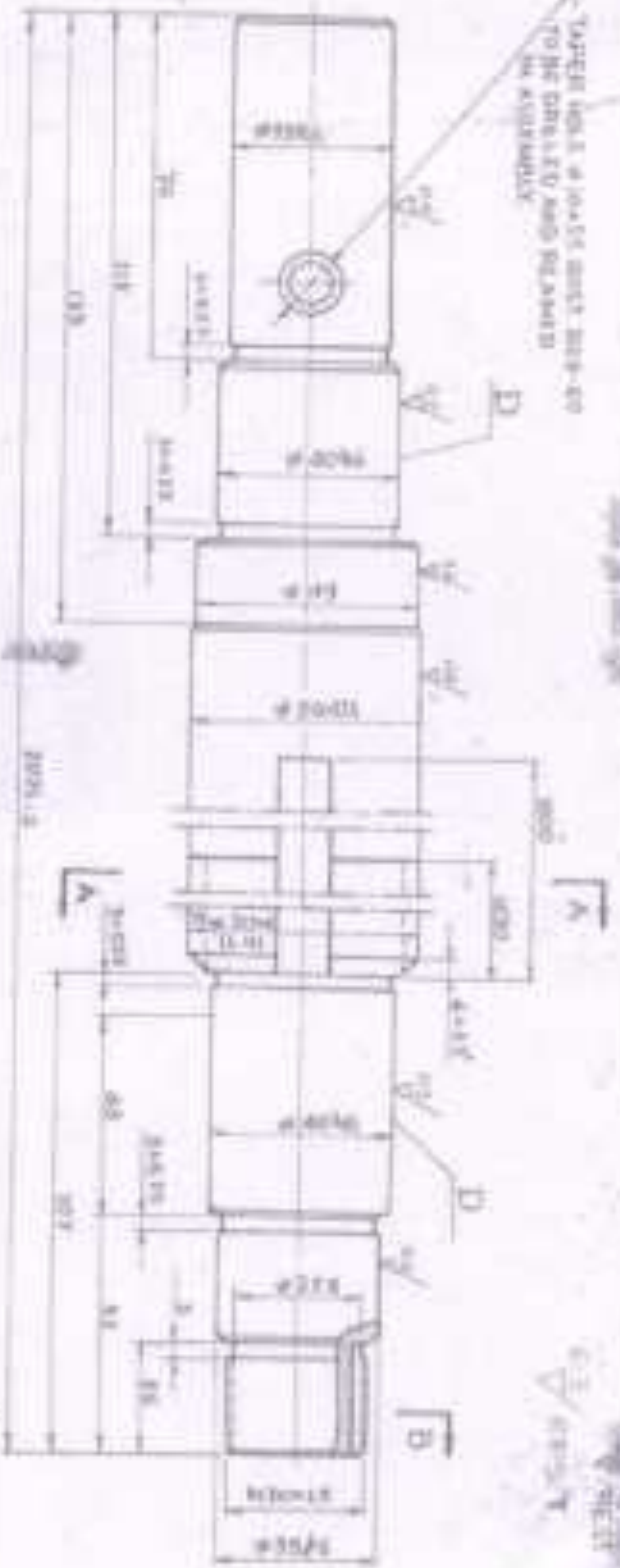

1. REPORT OF WORKS DIV OF WORKS TO ENGINE, STRONGHOLD
2. TYPING OF WORKS DIVISION OF WORKS TO ENGINE, STRONGHOLD
3. TYPING OF WORKS DIVISION OF WORKS TO ENGINE, STRONGHOLD
4. TYPING OF WORKS DIVISION OF WORKS TO ENGINE, STRONGHOLD
5. TYPING OF WORKS DIVISION OF WORKS TO ENGINE, STRONGHOLD
6. TYPING OF WORKS DIVISION OF WORKS TO ENGINE, STRONGHOLD
7. TYPING OF WORKS DIVISION OF WORKS TO ENGINE, STRONGHOLD
8. TYPING OF WORKS DIVISION OF WORKS TO ENGINE, STRONGHOLD
9. TYPING OF WORKS DIVISION OF WORKS TO ENGINE, STRONGHOLD
10. TYPING OF WORKS DIVISION OF WORKS TO ENGINE, STRONGHOLD



NAME OF WORKS DIVISION

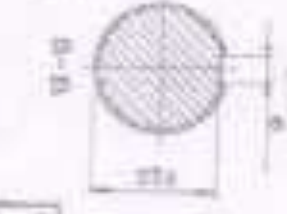
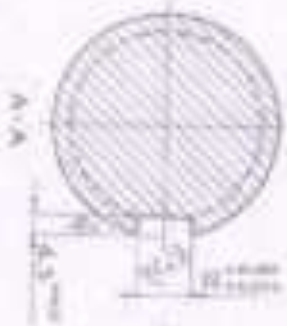

NO.	DESCRIPTION	QTY	UNIT	REMARKS
1	BOLT	1	PC	
2	NUT	1	PC	
3	WASHER	1	PC	
4	SPACER	1	PC	

Signature

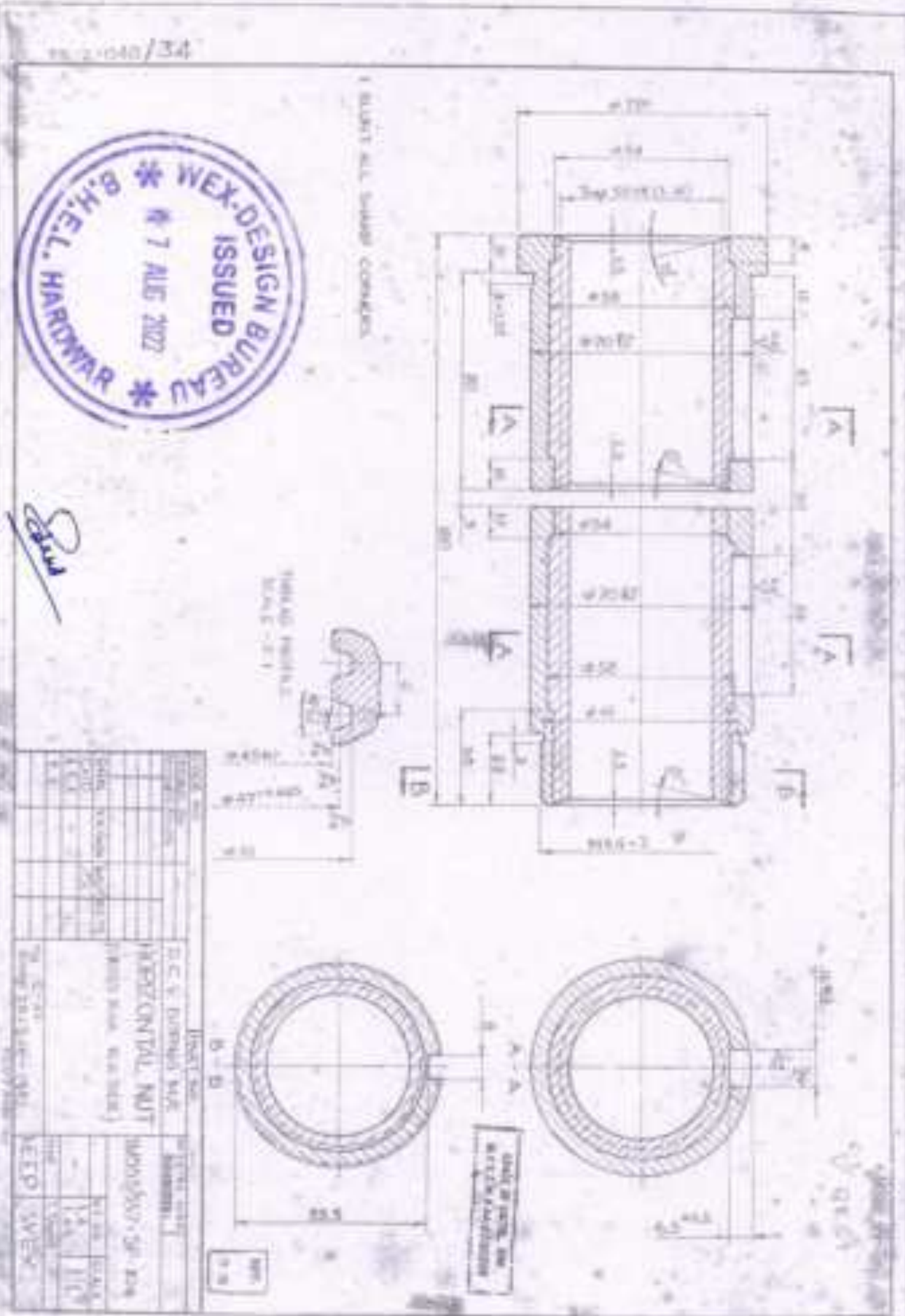

*Shiv*

DATE	ISSUED	BY	FOR
07/08/22	07/08/22	SHIV	FOR
08/08/22			
09/08/22			
10/08/22			
11/08/22			
12/08/22			
01/09/22			
02/09/22			
03/09/22			
04/09/22			
05/09/22			
06/09/22			
07/09/22			
08/09/22			
09/09/22			
10/09/22			
11/09/22			
12/09/22			
01/10/23			
02/10/23			
03/10/23			
04/10/23			
05/10/23			
06/10/23			
07/10/23			
08/10/23			
09/10/23			
10/10/23			
11/10/23			
12/10/23			
01/11/24			
02/11/24			
03/11/24			
04/11/24			
05/11/24			
06/11/24			
07/11/24			
08/11/24			
09/11/24			
10/11/24			
11/11/24			
12/11/24			
01/12/25			
02/12/25			
03/12/25			
04/12/25			
05/12/25			
06/12/25			
07/12/25			
08/12/25			
09/12/25			
10/12/25			
11/12/25			
12/12/25			
01/01/26			
02/01/26			
03/01/26			
04/01/26			
05/01/26			
06/01/26			
07/01/26			
08/01/26			
09/01/26			
10/01/26			
11/01/26			
12/01/26			
01/02/27			
02/02/27			
03/02/27			
04/02/27			
05/02/27			
06/02/27			
07/02/27			
08/02/27			
09/02/27			
10/02/27			
11/02/27			
12/02/27			
01/03/28			
02/03/28			
03/03/28			
04/03/28			
05/03/28			
06/03/28			
07/03/28			
08/03/28			
09/03/28			
10/03/28			
11/03/28			
12/03/28			
01/04/29			
02/04/29			
03/04/29			
04/04/29			
05/04/29			
06/04/29			
07/04/29			
08/04/29			
09/04/29			
10/04/29			
11/04/29			
12/04/29			
01/05/30			
02/05/30			
03/05/30			
04/05/30			
05/05/30			
06/05/30			
07/05/30			
08/05/30			
09/05/30			
10/05/30			
11/05/30			
12/05/30			
01/06/31			
02/06/31			
03/06/31			
04/06/31			
05/06/31			
06/06/31			
07/06/31			
08/06/31			
09/06/31			
10/06/31			
11/06/31			
12/06/31			
01/07/32			
02/07/32			
03/07/32			
04/07/32			
05/07/32			
06/07/32			
07/07/32			
08/07/32			
09/07/32			
10/07/32			
11/07/32			
12/07/32			
01/08/33			
02/08/33			
03/08/33			
04/08/33			
05/08/33			
06/08/33			
07/08/33			
08/08/33			
09/08/33			
10/08/33			
11/08/33			
12/08/33			
01/09/34			
02/09/34			
03/09/34			
04/09/34			
05/09/34			
06/09/34			
07/09/34			
08/09/34			
09/09/34			
10/09/34			
11/09/34			
12/09/34			
01/10/35			
02/10/35			
03/10/35			
04/10/35			
05/10/35			
06/10/35			
07/10/35			
08/10/35			
09/10/35			
10/10/35			
11/10/35			
12/10/35			
01/11/36			
02/11/36			
03/11/36			
04/11/36			
05/11/36			
06/11/36			
07/11/36			
08/11/36			
09/11/36			
10/11/36			
11/11/36			
12/11/36			
01/12/37			
02/12/37			
03/12/37			
04/12/37			
05/12/37			
06/12/37			
07/12/37			
08/12/37			
09/12/37			
10/12/37			
11/12/37			
12/12/37			
01/01/38			
02/01/38			
03/01/38			
04/01/38			
05/01/38			
06/01/38			
07/01/38			
08/01/38			
09/01/38			
10/01/38			
11/01/38			
12/01/38			
01/02/39			
02/02/39			
03/02/39			
04/02/39			
05/02/39			
06/02/39			
07/02/39			
08/02/39			
09/02/39			
10/02/39			
11/02/39			
12/02/39			
01/03/40			
02/03/40			
03/03/40			
04/03/40			
05/03/40			
06/03/40			
07/03/40			
08/03/40			
09/03/40			
10/03/40			
11/03/40			
12/03/40			
01/04/41			
02/04/41			
03/04/41			
04/04/41			
05/04/41			
06/04/41			
07/04/41			
08/04/41			
09/04/41			
10/04/41			
11/04/41			
12/04/41			
01/05/42			
02/05/42			
03/05/42			
04/05/42			
05/05/42			
06/05/42			
07/05/42			
08/05/42			
09/05/42			
10/05/42			
11/05/42			
12/05/42			
01/06/43			
02/06/43			
03/06/43			
04/06/43			
05/06/43			
06/06/43			
07/06/43			
08/06/43			
09/06/43			
10/06/43			
11/06/43			
12/06/43			
01/07/44			
02/07/44			
03/07/44			
04/07/44			
05/07/44			
06/07/44			
07/07/44			
08/07/44			
09/07/44			
10/07/44			
11/07/44			
12/07/44			
01/08/45			
02/08/45			
03/08/45			
04/08/45			
05/08/45			
06/08/45			
07/08/45			
08/08/45			
09/08/45			
10/08/45			
11/08/45			
12/08/45			
01/09/46			
02/09/46			
03/09/46			
04/09/46			
05/09/46			
06/09/46			
07/09/46			
08/09/46			
09/09/46			
10/09/46			
11/09/46			
12/09/46			
01/10/47			
02/10/47			
03/10/47			
04/10/47			
05/10/47			
06/10/47			
07/10/47			
08/10/47			
09/10/47			
10/10/47			
11/10/47			
12/10/47			
01/11/48			
02/11/48			
03/11/48			
04/11/48			
05/11/48			
06/11/48			
07/11/48			
08/11/48			
09/11/48			
10/11/48			
11/11/48			
12/11/48			
01/12/49			
02/			

Sample hole 4 grade only use as  
a guide only and not to be used  
in actual work

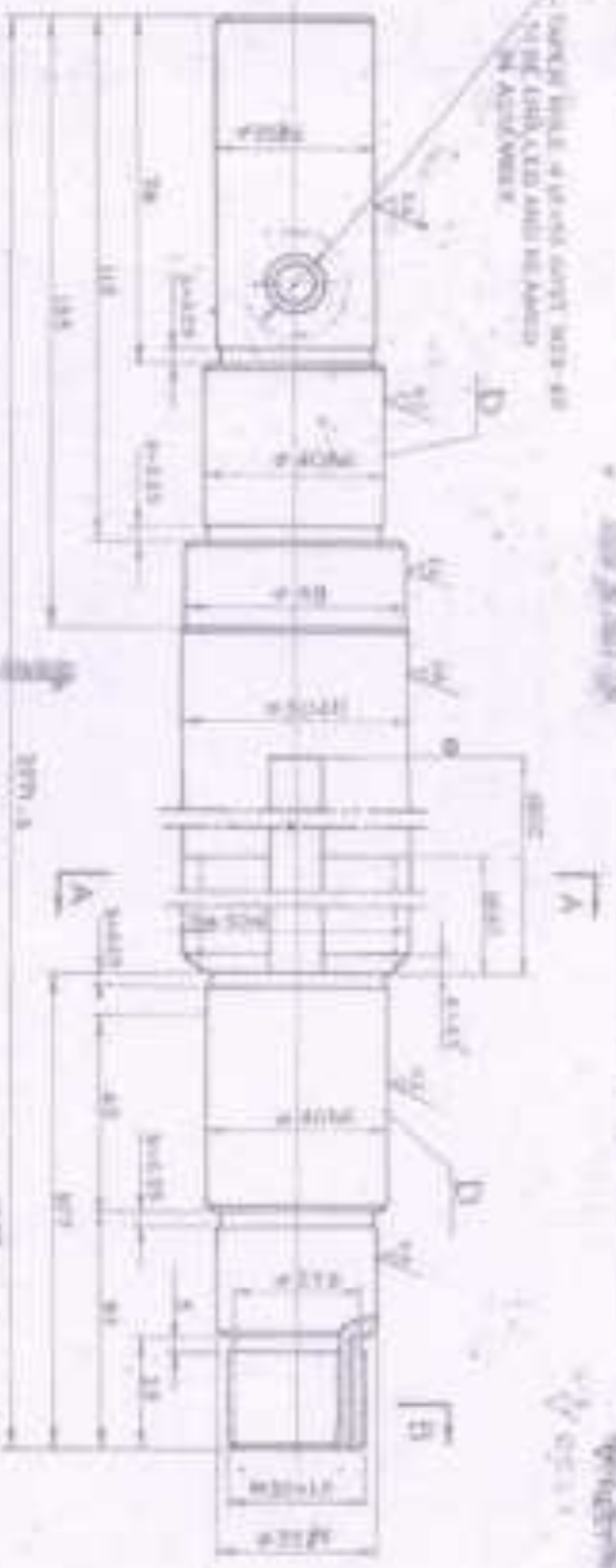

1. SUBJECT OR PARTS FOR OR OTHER TO EXAMINE (SPECIFY PART NUMBER, TRADE MARK)
2. TYPE OF SPECIAL EQUIPMENT OR SPECIAL APPARATUS NOT WORK TAKEN AS
3. OTHER PARTS OR THE SUBJECT OR PARTS NOT WORK TAKEN AS
4. NUMBER OF SPECIAL EQUIPMENT OR APPARATUS NOT WORK TAKEN AS
5. OTHER PARTS OR THE SUBJECT OR PARTS NOT WORK TAKEN AS
6. OTHER PARTS OR THE SUBJECT OR PARTS NOT WORK TAKEN AS
7. OTHER PARTS OR THE SUBJECT OR PARTS NOT WORK TAKEN AS
8. OTHER PARTS OR THE SUBJECT OR PARTS NOT WORK TAKEN AS
9. OTHER PARTS OR THE SUBJECT OR PARTS NOT WORK TAKEN AS
10. OTHER PARTS OR THE SUBJECT OR PARTS NOT WORK TAKEN AS

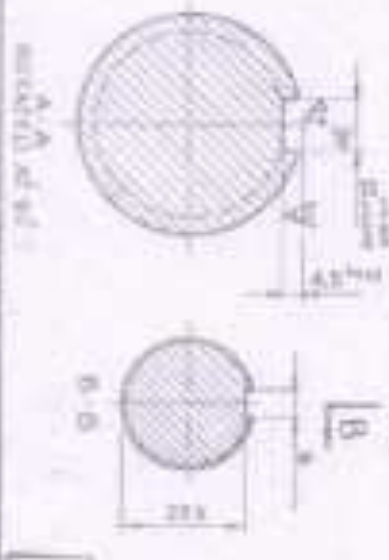
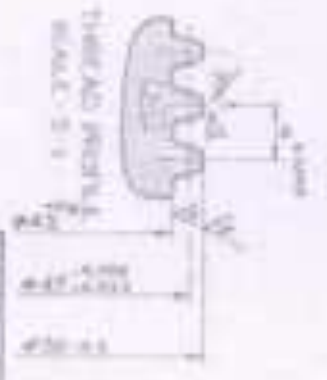

DATE OF ISSUE: 01/08/2007  
BY: B.H.F.L. HANOVER

NO.	REVISION	DATE	BY	CHKD
1				
2				
3				
4				
5				
6				
7				
8				
9				
10				

LEFT LEAD SCREW (Specs. P&I.)

WEX-DESIGN BUREAU

DATE OF ISSUE: 01/08/2007

BY: B.H.F.L. HANOVER

CHKD: B.H.F.L. HANOVER

APP: B.H.F.L. HANOVER

SCALE: 1:1

*[Handwritten signature]*





WITNESS SIGNATURE

PROJECT NAME: INDIAN AIR FORCE QUARTERS

DATE: 11/11/57

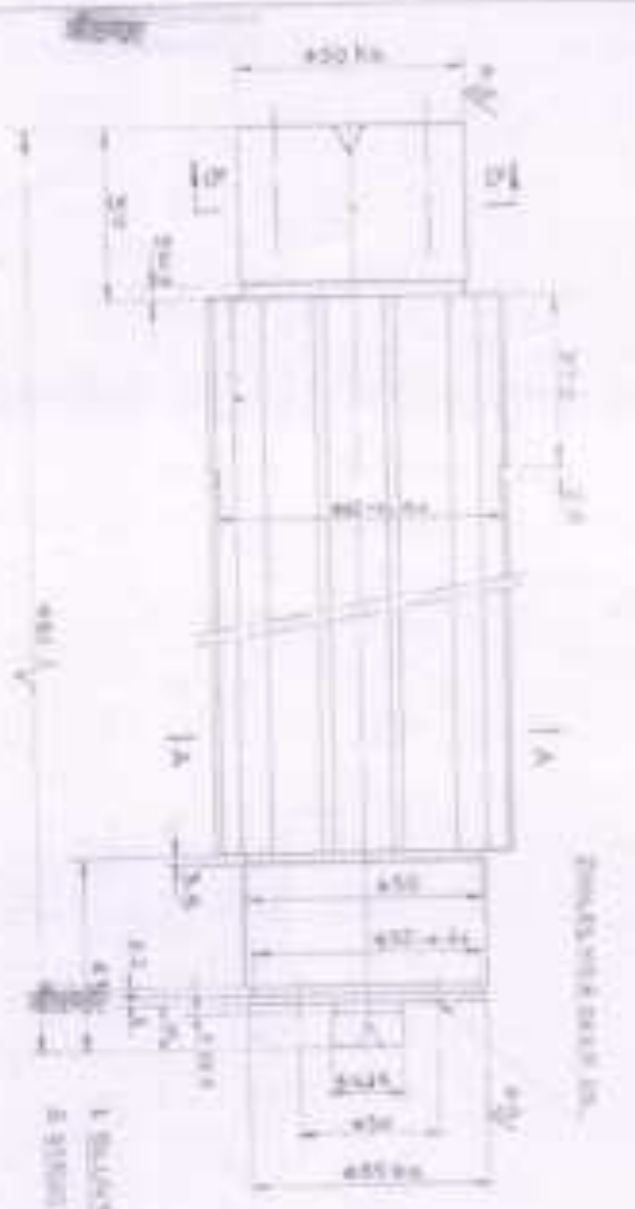

1. REFER ALL QUOTE CONDITIONS & SPECIFICATIONS REFER TO CONTRACT

DESIGN BUREAU  
ISSUED  
11/11/57  
M. S. HARWAR

NO.	DESCRIPTION	QTY	UNIT	REMARKS
1	CONCRETE			
2	STEEL			
3	BRICK			
4	PLASTER			
5	PAINT			
6	GLASS			
7	DOOR			
8	WINDOW			
9	ROOF			
10	FOUNDATION			

CONTRACTOR: SHRI. S. S. HARWAR  
 ADDRESS: 11/11/57  
 PROJECT: INDIAN AIR FORCE QUARTERS  
 DRAWING NO: 11/11/57  
 SCALE: 1/4" = 1'-0"  
 DATE: 11/11/57

*Handwritten signature*





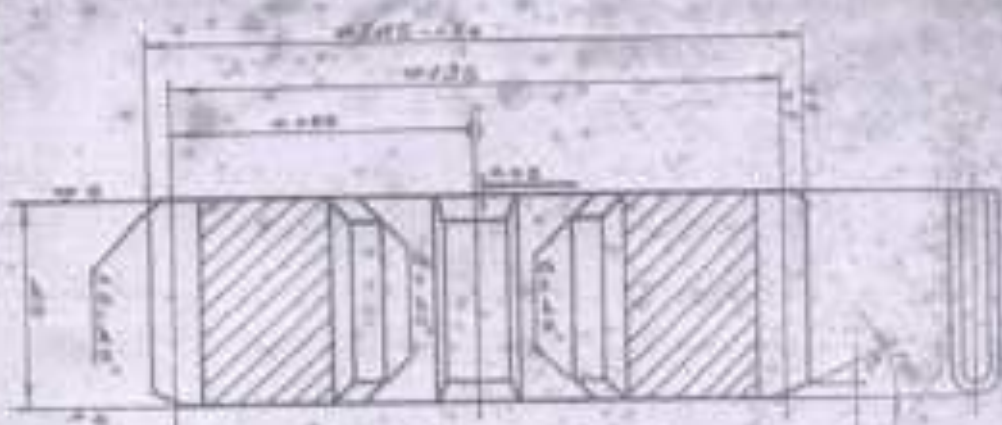

NO.	REVISION	DATE	BY	CHKD.	APP.
1					
2					
3					
4					
5					
6					
7					
8					
9					
10					

NO.	REVISION	DATE	BY	CHKD.	APP.
1					
2					
3					
4					
5					
6					
7					
8					
9					
10					

*Sum*  
*SP 20*

1/1

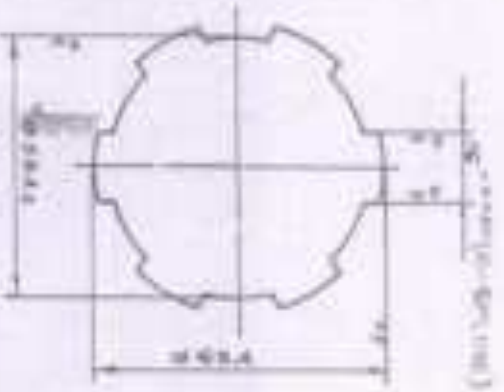
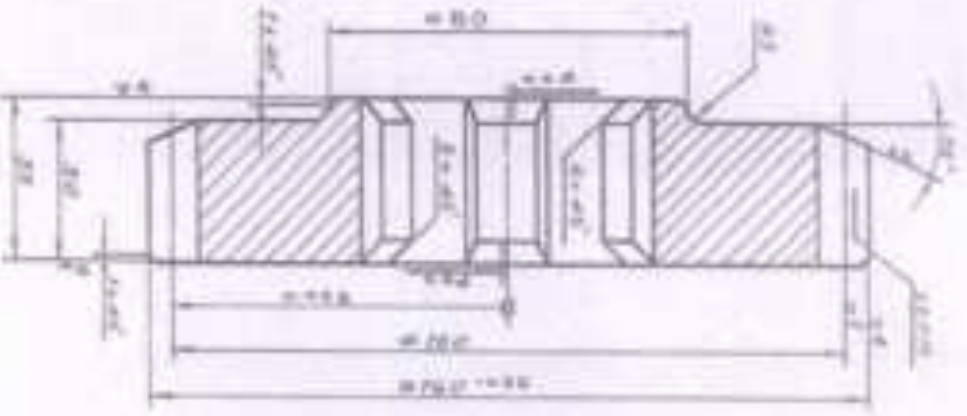

NO.	DESCRIPTION	QTY.	UNIT
1	SHAFT	1	PC
2	NUT	1	PC
3	WASHER	1	PC
4	FLANGE	1	PC

(24)

SP28

WEX-DESIGN BUREAU

WEX-DESIGN BUREAU  
 ISSUED  
 17 AUG 2021

NO.	DESCRIPTION	QTY.	UNIT
1	SHAFT	1	PC
2	NUT	1	PC
3	WASHER	1	PC
4	FLANGE	1	PC

*Signature*







Ze-9-004/19

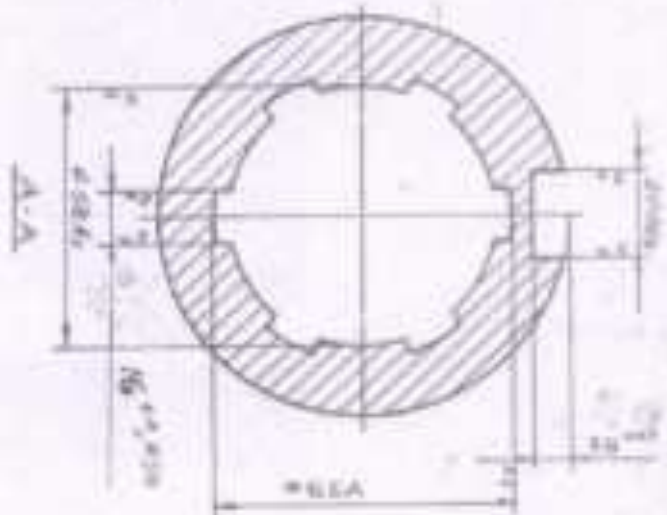
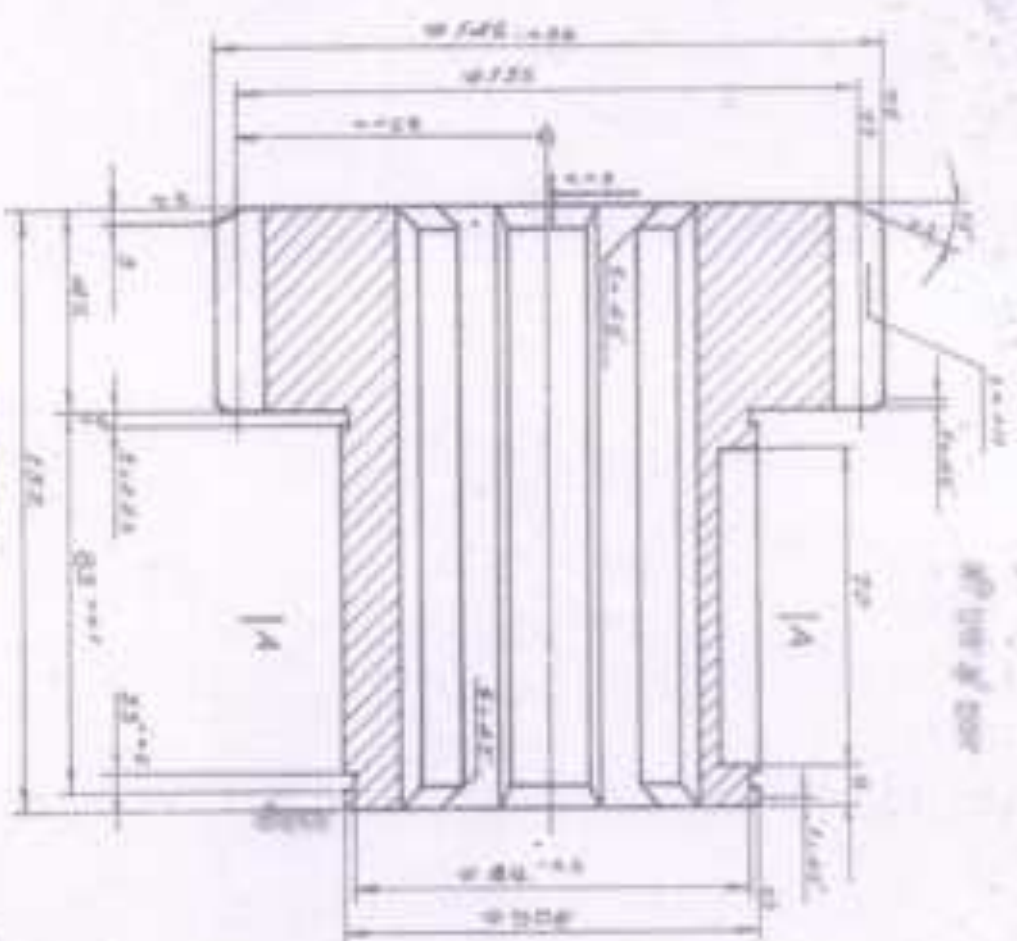

*Handwritten signature*

... ..

Drawn by	Checked by	Scale	Material
Part No.	Project No.	Rev.	Notes
Author	Design	Check	Approved
DATE	DATE	DATE	DATE

Author	Design	Check	Approved
DATE	DATE	DATE	DATE

28



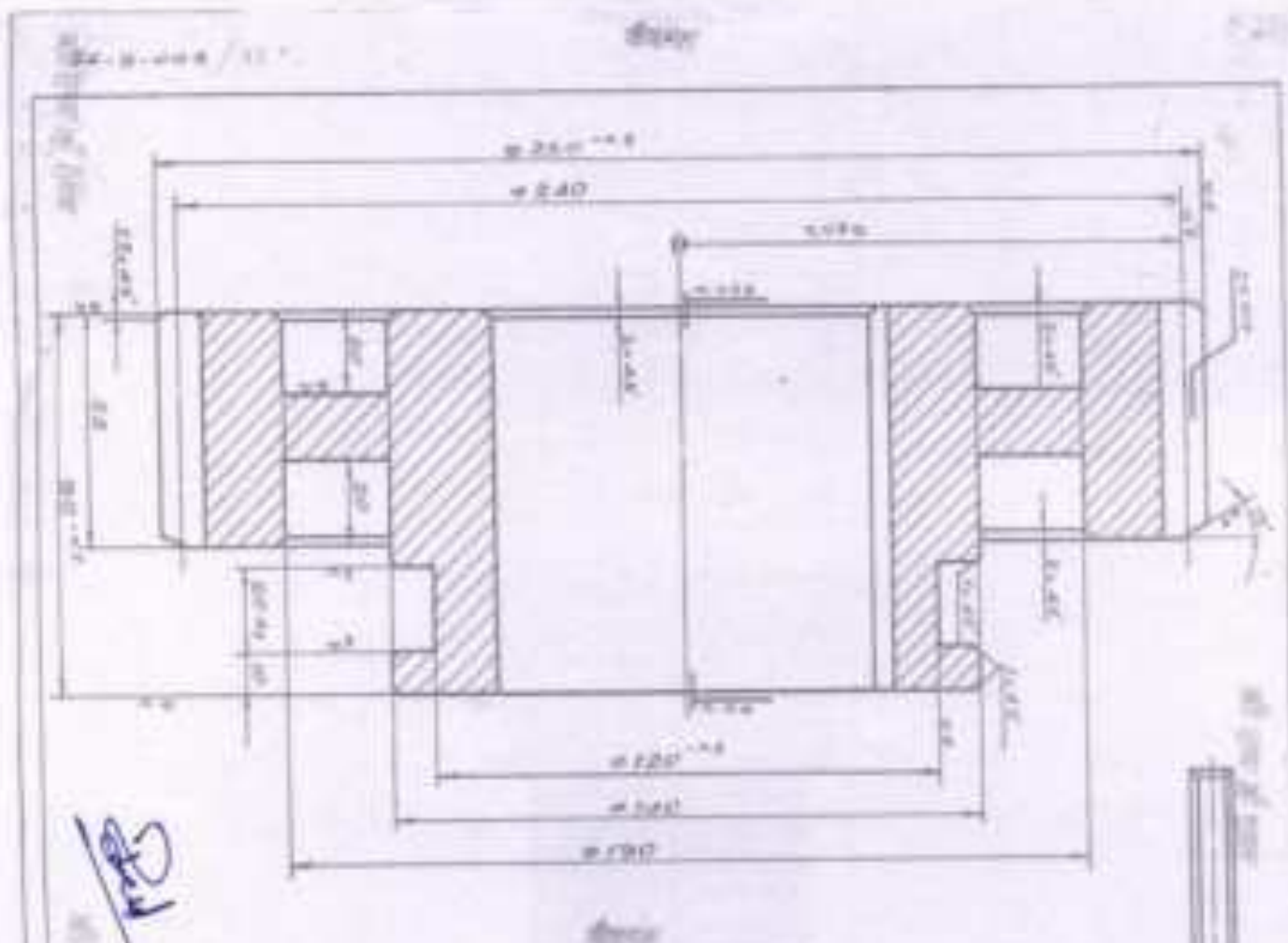

*Handwritten signature*

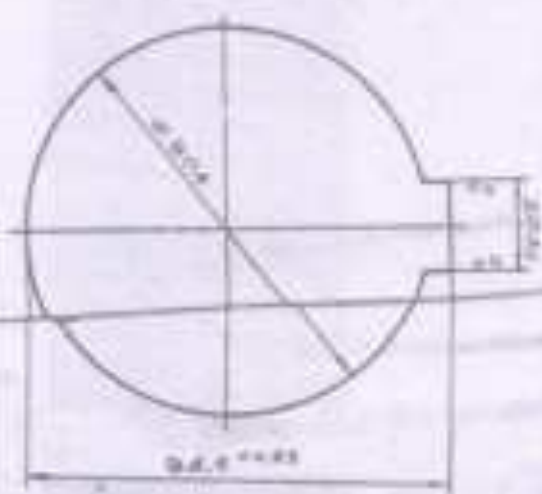

REVISIONS	NO.	DATE	BY

QUALITY ASSURANCE DEPARTMENT  
 10000 W. 10th Ave. Suite 100  
 Golden, CO 80401



NO.	DATE	BY	CHKD.

UNLESS INDICATED OTHERWISE, ALL DIMENSIONS ARE IN MILLIMETERS.  
 INFORMATION ON THIS DOCUMENT IS THE PROPERTY OF  
 BUSHY HEAVY ELECTRICALS LIMITED - IT MUST NOT BE LOANED, REPRODUCED  
 OR ADAPTED IN ANY MANNER WITHOUT THE WRITTEN PERMISSION OF THE COMPANY.

1578-154-SP-164

FIRST ANGLE PROJECTION

(ALL DIMENSIONS ARE IN MM)

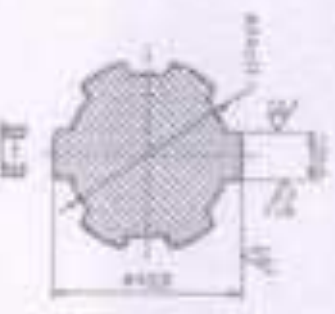
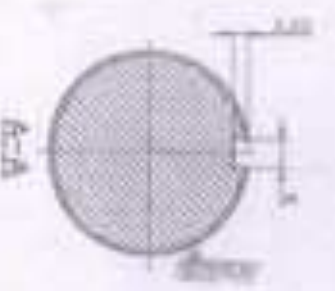
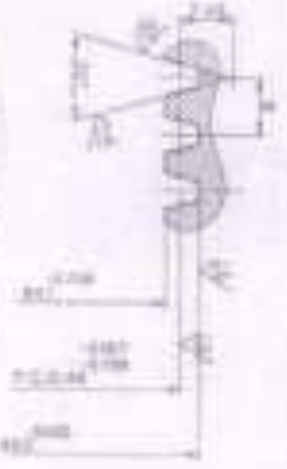
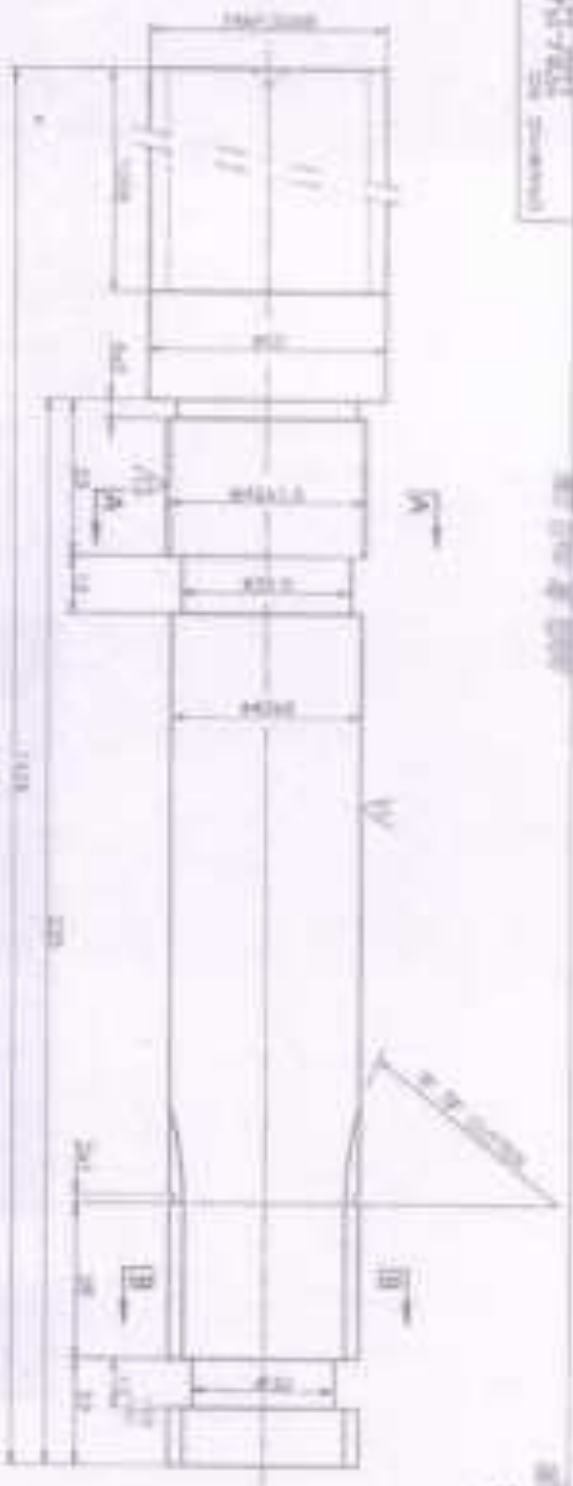

LEAD SCREW FINISHED



NO.	REV.	DATE	BY	CHKD.	DESCRIPTION
1					

ITEM NO.	QTY.	DESCRIPTION	UNIT
1	1	LEAD SCREW	PC

TYPE OF PRODUCT: V-BORING M/C NAME OF CUSTOMER: [blank]	MAT - 10001 NAME NO: 0-100 RICK-111
BUSHY HEAVY ELECTRICALS LTD. HARIDWAR	DATE: [blank] BY: [blank] CHECKED: [blank]
TITLE: LEAD SCREW	DRAWING NO.: 1578-154-SP-164-00 SHEET NO.: 11

*Spd*

1578-154-SP-164  
 W/ THE FILE





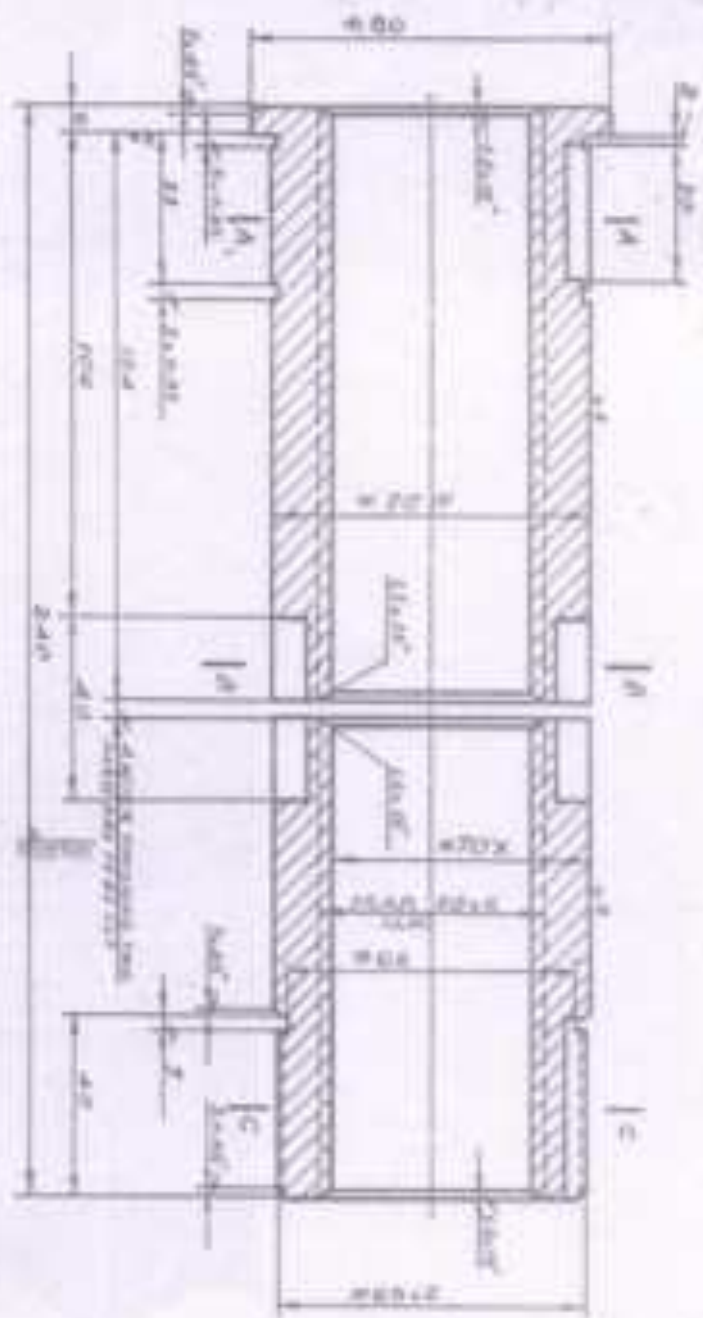

1/100

1/100

1/100

1/100

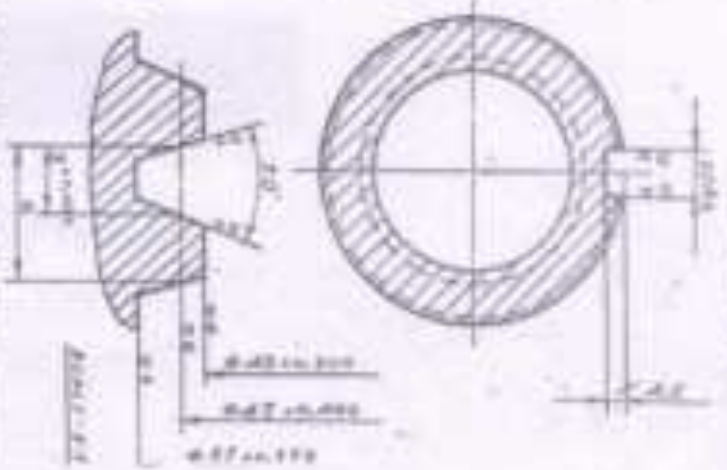
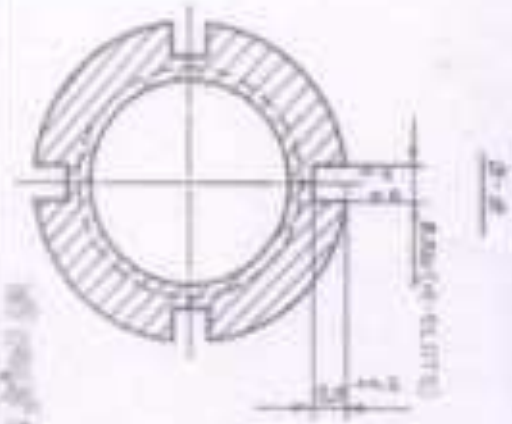
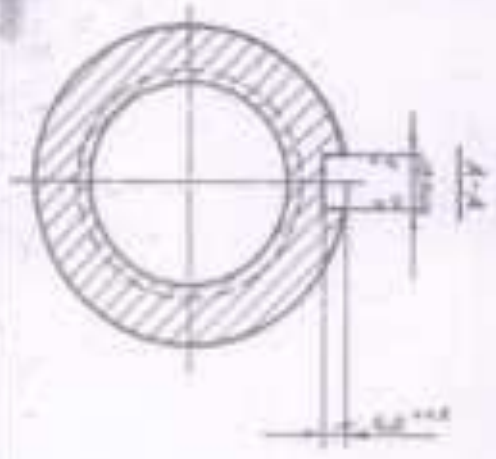

DESIGN & DRAWING  
 ISSUED  
 17 AUG 2022

NO.	REVISION	DATE	BY	CHKD.	APP.
1					
2					
3					
4					
5					
6					
7					
8					
9					
10					

2022  
 17 AUG 2022  
 17 AUG 2022







Copyright and Confidential  
 THE INFORMATION ON THIS DOCUMENT IS THE PROPERTY OF  
 BRAMPTON HEAVY ELECTRICALS LIMITED. IT MUST NOT BE USED DIRECTLY  
 OR INDIRECTLY IN ANY WAY DETRIMENTAL TO THE INTEREST OF THE COMPANY.

DRAWING NO. 2B6600-SP.

FIRST ANGLE PROJECTION

(ALL DIMENSIONS ARE IN MM)

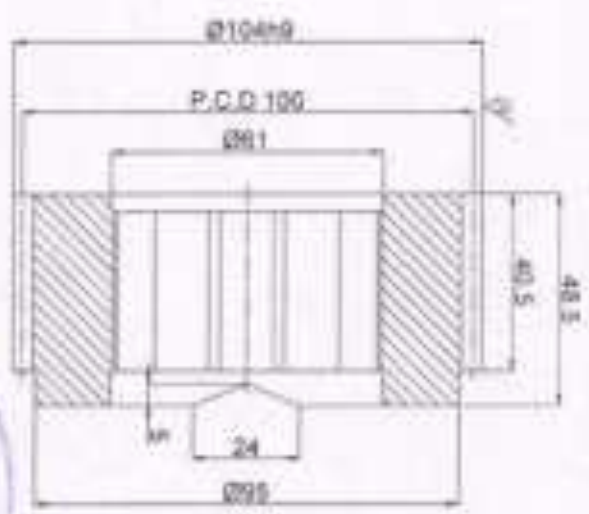
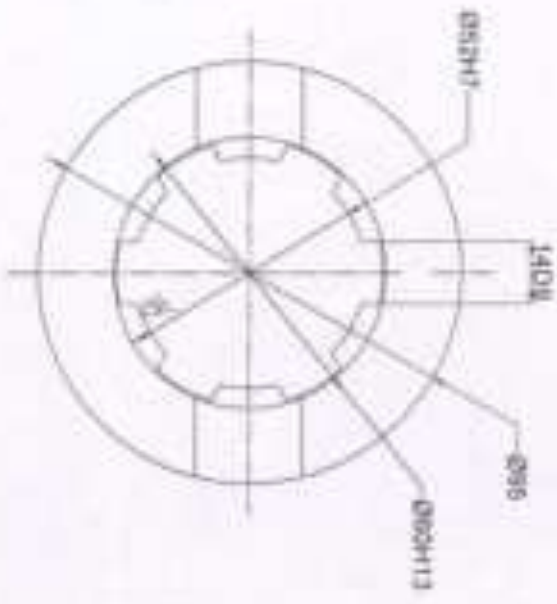

REV	DESCRIPTION	DATE	BY	CHKD
1	ISSUED			
2	REVISED			
3	REVISED			
4	REVISED			
5	REVISED			
6	REVISED			
7	REVISED			
8	REVISED			
9	REVISED			
10	REVISED			

DRAWING NO. 2B6600-SP. TITLE: COUPLING GEAR DATE: 11/11/2011 DRAWN BY: [Signature] CHECKED BY: [Signature]	SAMPLE NO. 2B6600-SP. DATE: 11/11/2011	TYPE OF PRODUCT: H. GEARING W/C NAME OF CUSTOMER/ PROJECT: [Blank] TYPE OF UNIT: [Blank]	BRANCH: [Blank] DIVISION: [Blank] PROJECT: [Blank]
--	---	--	--









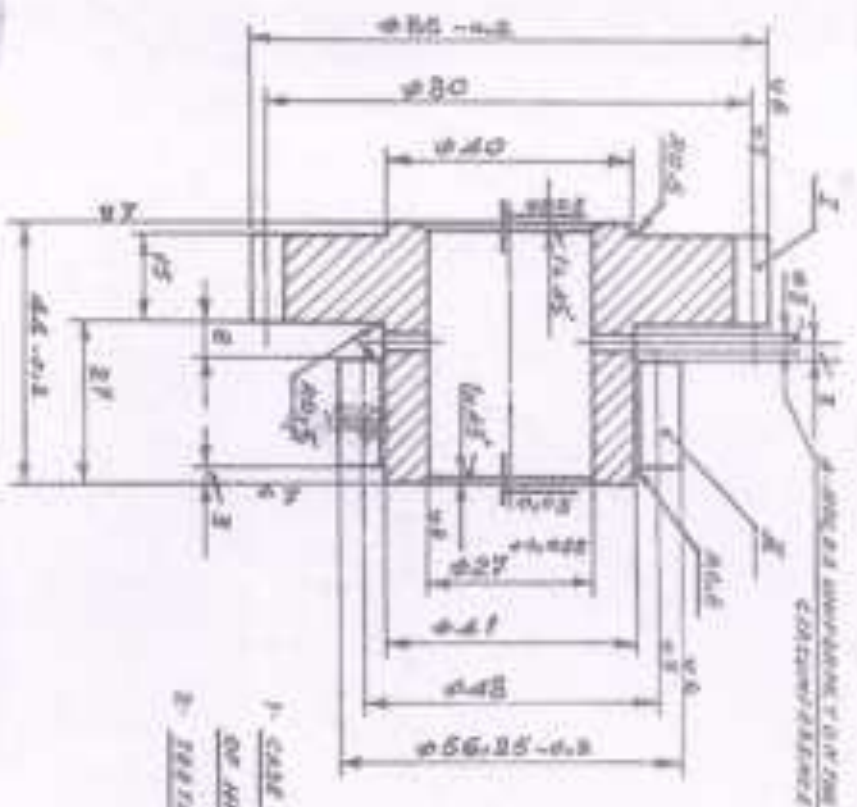

V4 BEAT

ANALYSIS	I	X
NO. OF TESTS	10	10
PERCENTAGE AMPLI	20%	20%
LEADIN OF EQUATION	20.20-24.20	20.20-24.20
ANOMAL	(MATHS)	(MATHS)
CORRECTION	00.10	00.10
MAKING PART DROPS	20.20	20.20

1. CASE CARBORUNDUM FOR DEPTH OF 0.3 MM. TO ATTAIN A HARDNESS OF HRC 63.  
 2. PARTS ARE TO BE INSPECTION AND APPROVED TO HRC 63-64.

*SPD*



CODE NO.	-	PART NO.	-
MANUFACTURE NO.	24015	GEAR	2020A-SP-41
DESIGN	CONCEPT	QUAL/ISSUE	SCALE
CHD.	1/2020A	11/2020A	-
APP.	1/2020A	11/2020A	1:1
RE	1/2020A	11/2020A	
A. E. UNIT		STEEL (HPT)/EN50	HEED WEX







74-6-012/63 42

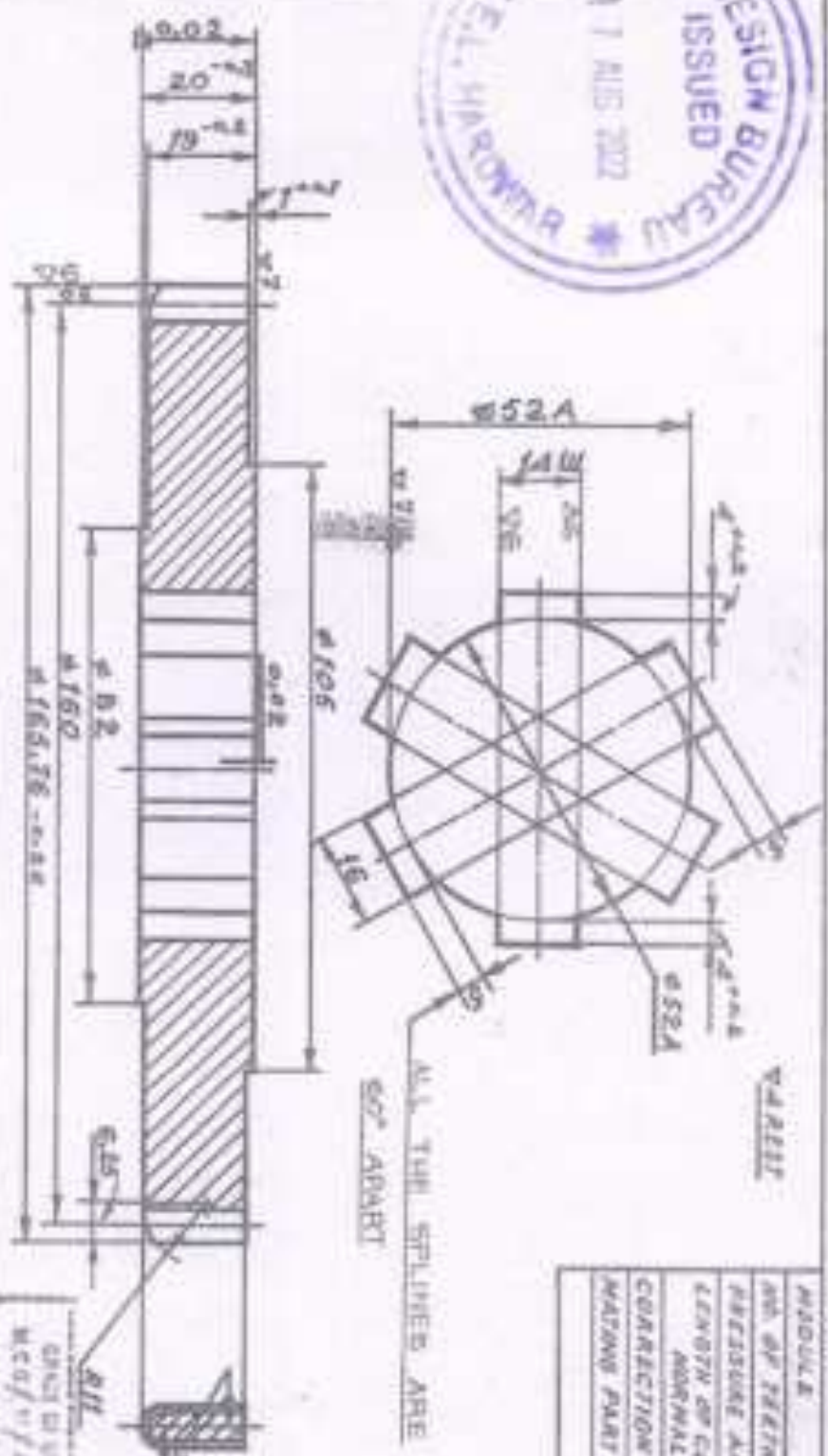

MODULE	2.5
NO. OF TEETH	64
PRESSURE ANGLE	20°
LENGTH OF COMMON NORMAL	57.6648 (17.7171)
CORRECTION	+0.55
MATING PART NO.	2A151

\* CASE HARDENING TO A DEPTH OF 0.2 MM, TO ATTAIN A HARDNESS OF HRC 58.  
\* TEETH ARE TO BE INSPECTED ACCORDING TO SPEC-88

CODE NO.	---	PART NO.	---	26924/2
HORIZONTAL SHAFT N/C		GEAR		
DATE	PROB.	ENG.	CHK.	APP.
CHKD.	W/APP.	APP.	APP.	APP.
REV.	REV.	REV.	REV.	REV.
APP.	APP.	APP.	APP.	APP.
12 INCH GAGE				26924-SP-70
LETTER WIND SCALE		SCALE 1:1		
HELP		WSP/06/04		

*Handwritten signature*

1000000000

1000000000

DATE	10/10/2012	BY	...
DESIGNED BY	...	CHECKED BY	...
DATE	...	BY	...
DESIGNED BY	...	CHECKED BY	...
DATE	...	BY	...
DESIGNED BY	...	CHECKED BY	...

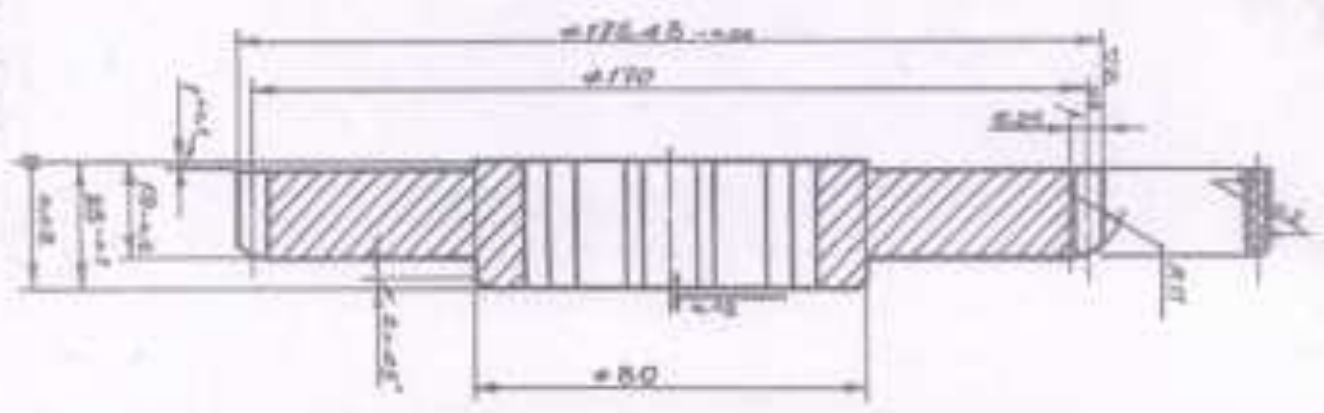
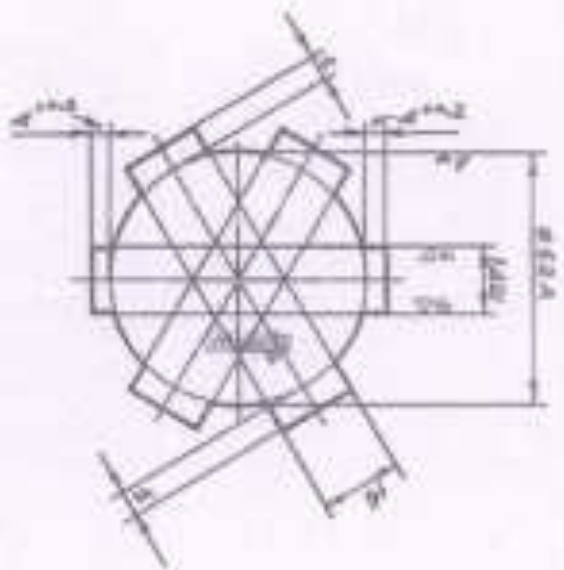

- ALL DIMENSIONS IN MILLIMETERS UNLESS OTHERWISE SPECIFIED.
- ALL DIMENSIONS ARE TO BE TAKEN TO THE CENTER OF THE HOLE.
- ALL DIMENSIONS ARE TO BE TAKEN TO THE CENTER OF THE HOLE.

*Handwritten signature*

DATE	10/10/2012	BY	...
DESIGNED BY	...	CHECKED BY	...
DATE	...	BY	...
DESIGNED BY	...	CHECKED BY	...
DATE	...	BY	...
DESIGNED BY	...	CHECKED BY	...

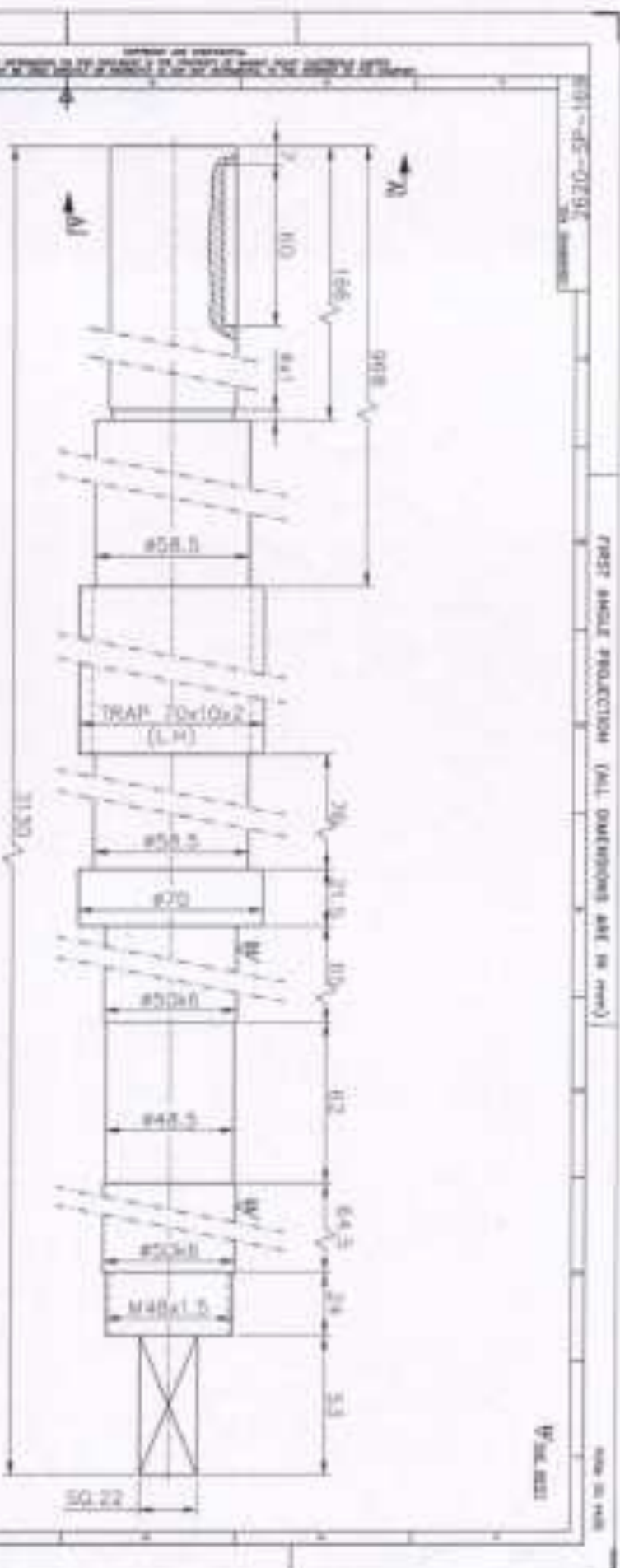

SEC--AA

*Shop*

1. SHOW ALL DIMENSIONS

<b>REVISIONS</b> NO. REV. DATE BY 1 1 2022 [Signature]		<b>DATE</b> 07/07/2022	
<b>DESIGNER</b> [Signature]		<b>CHECKED</b> [Signature]	
<b>SCALE</b> 1:1		<b>MATERIAL</b> MS	
<b>QUANTITY</b> 1		<b>MARKING</b> 28231-SP-109	
<b>PROJECT</b> LEAD SCREW		<b>DATE OF ISSUE</b> 07/07/2022	

Page No. 54/55

28



THREAD PROFILE  
SCALE: 1:1 NTS

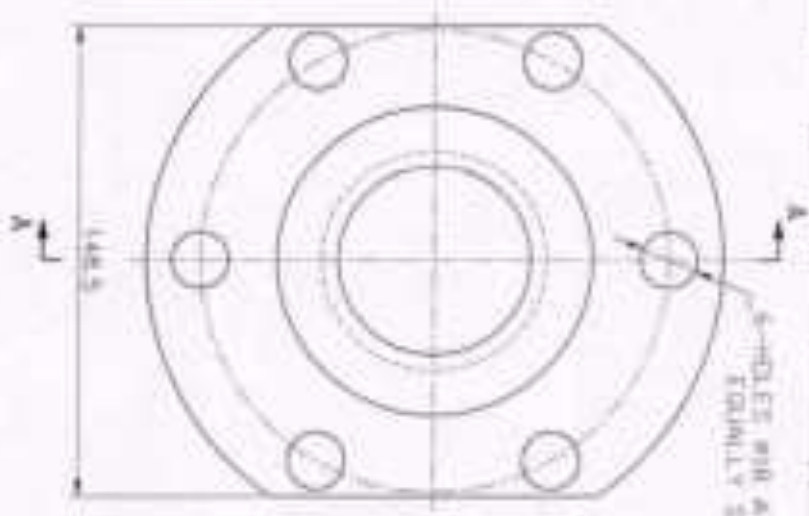
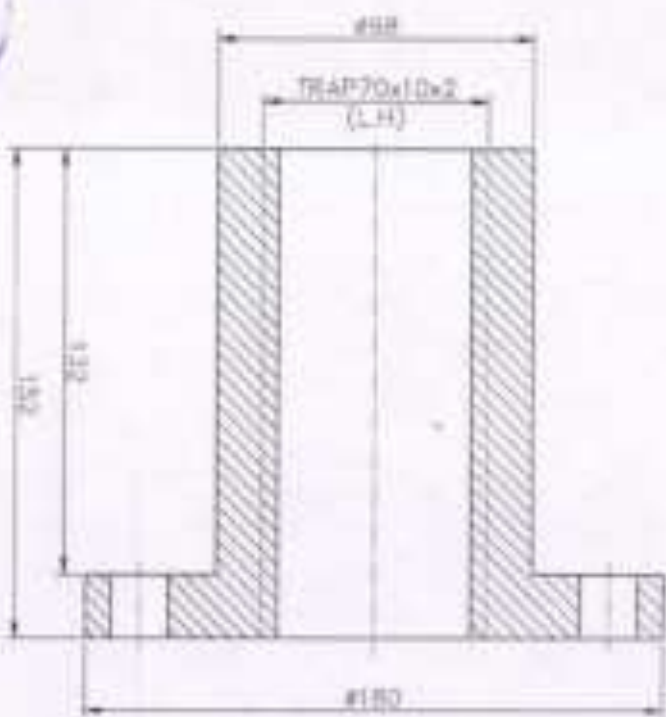
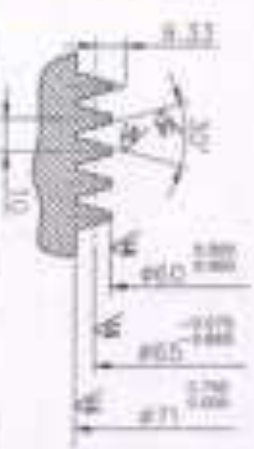

6 HOLES WITH 10mm DIA AT 90 DEGREE  
EQUALLY SPACED

FIRST ANGLE PROJECTION (ALL DIMENSIONS ARE IN mm)

NO.	REV.	DATE	BY	APP.	DESCRIPTION
01					INITIAL DESIGN
02					REVISION
03					REVISION
04					REVISION
05					REVISION
06					REVISION
07					REVISION
08					REVISION
09					REVISION
10					REVISION

DESIGNER	DATE	SCALE	PROJ. NO.	REV. NO.
...	...	...	...	...

DATE OF ORDER	DATE OF DELIVERY	DATE OF RECEIPT	DATE OF PAYMENT
...	...	...	...

ITEM NO.	DESCRIPTION	QTY	UNIT	PRICE	TOTAL
...	...	...	...	...	...

DATE OF ORDER	DATE OF DELIVERY	DATE OF RECEIPT	DATE OF PAYMENT
...	...	...	...

DATE OF ORDER	DATE OF DELIVERY	DATE OF RECEIPT	DATE OF PAYMENT
...	...	...	...

INDICATE ALL DIMENSIONS

Page No. 55/55

