 419 - 401	<b>BHARAT HEAVY ELECTRICALS LIMITED</b> (A Government of India Undertaking) <b>TIRUCHIRAPPALLI - 620 014</b> <b>SUBCONTRACTING / ADVANCED TECHNOLOGY PRODUCTS</b>	
	<b>Telephone:</b> 0431 – 2575751, 2571108 <b>Fax:</b> 0431 – 2576804	<b>E- mail:</b> <a href="mailto:arumugaraja@bheltry.co.in">arumugaraja@bheltry.co.in</a> or <a href="mailto:mpvelu@bheltry.co.in">mpvelu@bheltry.co.in</a>
<b>Enquiry Title :</b> Washer, Lock washer, Lock plate and Tab washer fabrication	<b>Enquiry Number</b>	<b>627004E</b>
	<b>Date</b>	<b>17.08.2017</b>
	<b>Due Date</b>	<b>08.09.2017</b>

Kindly submit your techno-commercial & price-bids separately for '**Washer, Lock washer, Lock plate and Tab washer fabrication**' in a sealed cover addressed to

**The Addl. General Manager**  
**Sub-contracting/ATP**  
**Building-2&4 (First Floor)**  
**Bharat Heavy Electricals Limited**  
**Tiruchirappalli-14**

duly super-scribing the above **Enquiry Number** and **Due date**.

The offers subject to the acceptance of terms and conditions enclosed should reach us before **14.00 hrs** on the due date. The tender will be opened at **14.30 hrs** on the due date in the presence of Tenderers, who are all present.

**Documents submitted with the offer shall be signed and stamped in each page by authorized representative of the bidder;** documents not signed and stamped by the authorized signatory of the bidder shall not be accepted and considered for evaluation of the bid.

REFER THE ENCLOSED ANNEXURES FOR SCOPE OF WORK AND DETAILED TERMS & CONDITIONS:

1. Annexure -1 for Scope of work & Delivery conditions
2. Annexure - A Terms & conditions of Enquiry
3. Annexure – B Important points for processing attested material
4. Annexure - C Techno-commercial bid
5. Annexure - N Applicable for New Vendors only
6. Drawing – Sketch A

The following points may be noted before submission of tenders:

1. Tenders received after the prescribed time will not be considered for tender opening
2. The enclosed drawings & procedures shall be returned
3. Vendors who are not registered with BHEL-Trichy must fill Annexure-N & attach necessary documents

  
 For Bharat Heavy Electricals Limited  
**RUMUGA RAJA**  
**Sr. Engineer**  
**Sub Contracting / ATP**  
**BHEL, TRICHY - 620 014.**



## BHARAT HEAVY ELECTRICALS LIMITED

TIRUCHIRAPPALLI - 620 014

SUB CONTRACTING / ADVANCED TECHNOLOGY PRODUCTS  
ANNEXURE TO ENQUIRY No. 627 004E / Dt. 17-08-2017

### COMPONENT DETAILS:-

Sl. No	DESCRIPTION & DRAWING No.	RAW MATERIAL SUPPLY DETAILS	WORK ORDER & DU – PART No	Reqd Qty. (Nos)
1)	Sl. No:01 - Washer-21 Sketch-A	Sheet 1 x 1500 x 3000 mm Qty :- 1 No. Sheet 1 x 1110 x 1690 mm Qty :- 1 No. Material Specn: SA240 TYP 321	D135- 001-1-93-130 000-0226	156
2)	Sl. No:02 - Lock Washer-17 Sketch-A		D135- 001-1-93-170 000-0109	696
3)	Sl. No:03 - Lock Washer Sketch-A		D135- 001-1-93-112 000-0111	72
4)	Sl. No:04 - Lock Plate Sketch-A		D135- 001-1-93-129 000-0108	180
5)	Sl. No:05 - Lock Washer Sketch-A		D135- 001-1-93-129 000-0105	360
6)	Sl. No:06 - Tab Washer Sketch-A		D135- 001-1-93-128 000-0120	408

### SCOPE OF OPERATIONS: -

1. Collection of Raw materials & attestation from BHEL with relevant documents.
2. Verification of raw material size and specification and other requirements as indicated in Purchase Order (Raw material supply details).
3. Operations Process Sheet should be prepared and submitted for approval from OP&C / BHEL.
4. Carry out Wire cutting or Water jet cutting or Die punching as per the drawing/sketch & OPS requirements.
5. Final Inspection clearance from QC / BHEL & QS / NPCIL.
6. After completion, W.O. no., Du-Part no., material specification, attestation no., and quantity details are to be engraved on the common tag plate and to be attached along with the finished component before packing it for despatch.
7. Safe packing and despatching of the finished components to ATP-BHEL/Trichy through component stores / Ward-27.

### GENERAL NOTES: -

1. Offer shall be given in **Rate per piece** for each serial number. However, combined value of all the items will be considered for 'L1' Rate.
2. Balance materials/ Cut bits if any is to be returned back to BHEL, Trichy with identification details.
3. Deposition of finished components with identification details and proper protection at component stores (ward-27) / BHEL / Trichy-14.
4. Preparation of detailed dimensional report and getting approval from QC/BHEL in Triplicate and the same shall be handed over to Subcontracting / ATP.
5. The invoice (Three copies) shall be addressed to Dy. General Manager / Finance and the same may be routed through Senior Manager / Subcontracting / ATP.

### DELIVERY SCHEDULE: -

Within 60-days from the date of material collection.

  
 17.08.2017  
**S. ARUMUGA RAJ**  
 Sr. Engineer  
 Sub Contracting / ATP  
 BHEL, TRICHY - 620 014  
 Sr. Engineer  
 Subcontracting / ATP



# BHARAT HEAVY ELECTRICALS LIMITED

TIRUCHIRAPPALLI - 620 014

## SUB CONTRACTING / ADVANCED TECHNOLOGY PRODUCTS

### ANNEXURE-A

#### TERMS & CONDITIONS TO ENQUIRY 627004E Dt. 17.08.2017

1. The tender will be operated on two part bid basis i.e.
  - I. Techno-Commercial Bid &
  - II. Price Bid
2. The offer is to be submitted in a single envelope containing two envelopes. i.e. Part - I (Techno Commercial Bid) and Part - II (Price Bid)
3. **Part – I (Techno-Commercial Bid):**
  - I. Duly Signed Tender Documents
  - II. Duly signed Annexures – A&B (Terms and Conditions & Important Points for Attested material processing)
  - III. Duly filled & signed Annexure – C (Techno-Commercial Bid)
  - IV. Signed and filled Annexure – N (*Applicable for New Vendors only*. Supporting documents should be submitted along with this bid)

This Part – I document should be sealed in a separate envelope by clearly marked “Part I – Techno - commercial bid” indicating Enquiry No., Due Date., address & reference of the bidder.

4. **Part – II (Price Bid):**
  - I. Duly filled and signed Quotation – Include all the costs and quote as **Rate per piece** basis (in Rs.) **for each Sl.No.** as in Annexure -1

This price bid should be sealed in a separate envelope by clearly marked “Part II – Price bid” indicating Enquiry No., Due Date., Address & reference of the bidder.

5. It is requested to put the above two envelopes (Techno-Commercial Bid & Price Bid) inside a separate larger sealed envelope and this envelope shall be super scribed as “Techno-Commercial Bid and Price Bid “for Enquiry No. 627004E Dt.: 17.08.2017 Due Dt.:08.09.2017

6. The offer should be addressed to:

**Addl. General Manager**  
**Sub-contracting / ATP**  
**2&4 Building (First Floor)**  
**Bharat Heavy Electricals Limited**  
**Tiruchirappalli - 620 014**

7. Any clarifications related to the enquiry should be addressed to [arumugaraja@bheltry.co.in](mailto:arumugaraja@bheltry.co.in) or [mpvelu@bheltry.co.in](mailto:mpvelu@bheltry.co.in) and NIT or Enquiry number should be mentioned in the subject. Any clarifications without the reference of tender number in the subject will not be entertained.
8. Any techno commercial clarifications/request for tender due date extensions with valid acceptable reasons to be addressed to BHEL prior to 48 hours of tender due date. BHEL reserves the rights to extend the due date as per their discretion.
9. Tenders should be free from CORRECTION AND ERASURES. Corrections if any must be attested; all amounts shall be indicated both in words as well as in figures. Where there is

  
**S. ARUMUGA RAJA**  
Sr. Engineer  
Sub Contracting / ATP  
BHEL, TRICHY - 620 014.

difference between amount quoted in words and figures, amount quoted in words shall only be considered.

**10. Discrepancy in “Words “& “Figures “**

- a. If, in the price structure quoted for the required goods/services/works, there is discrepancy between the unit price and the total price (which is obtained by multiplying the unit price by the quantity), the unit price shall prevail and the total price corrected accordingly, unless in the opinion of BHEL there is an obvious misplacement of the decimal point in the unit price, in which case the total price as quoted shall govern and the unit price corrected accordingly.
- b. If there is an error in a total corresponding to the addition or subtraction of subtotals, the subtotals shall prevail and the total shall be corrected; and
- c. If there is a discrepancy between words and figures, the amount in words shall prevail, unless the amount expressed in words is related to an arithmetic error, in which case the amount in figures shall prevail subject of (a) and (b) above.

**11. Taxes & Duties:**

All applicable taxes if payable as extra to the quoted price should be specifically stated in offers along with GST registration no. failing which BHEL will not be liable for payment of such taxes and duties. Our GSTN Code :- 33AAACB4146P2ZL Registered Address with GSTN :- Bharat Heavy Electricals Limited HPBP and SSTP, Thiruverumbur, Trichy – 14. (For GST related queries, pls contact:- [gst.try@bheltry.co.in](mailto:gst.try@bheltry.co.in))

Taxes if any will be paid in Full for each part payment, based on supporting documents.

12. The quoted rates shall be valid for at least **12 months** from the date of price bid opening. The quoted/Finalized rates shall be Firm till completion of the supplies.
13. On the due date of tender opening, only the technical bids will be opened. Technical bids will be evaluated by BHEL and clarifications required, if any, will be called for from the bidders on technical and commercial points. The price bids of techno-commercially suitable bidders will be opened on a later date with prior intimation to respective bidders.
14. Lowest price received against BHEL tenders need not be the technically acceptable one and in that case BHEL reserves the right not to consider the same. The purchaser shall be under no obligation to accept the lowest or any other tender and shall be entitled to accept or reject any tender in part or full without assigning any reason whatsoever.
15. BHEL reserves the right to negotiate or re-float the tender opened if L1 price is not the lowest acceptable price to them inter-alia other reasons.
16. BHEL deserves the right to increase or decrease the tendered quantity.

**17. Risk Purchase:**

BHEL at its option will be entitled to terminate the contract and to purchase elsewhere at the risk and cost of the seller either the whole of the goods or any part which the supplier has failed to deliver or dispatch within the time stipulated as aforesaid or if the same were not available, the best and the nearest available substitute thereof. The supplier shall be liable for any loss which BHEL may sustain by reason of such risk purchases in addition to LD at the maximum rate mentioned in the LD clause above.

**18. Bidders not confirming to the enquiry specification mentioned will be disqualified.**

19. Any corrigendum related to the enquiry will be hosted in the BHEL website only, Bidders should visit the website to keep themselves updated.

20. The correspondence between the bidder and BHEL through email is considered as valid document legally though not signed. It is treated as valid confirmations made on behalf of the respective company and comes under the legal ambit of the business transaction and hence binding on both the parties.
21. Bidders participating in the tender should declare in their technical bid whether they have been black-listed / kept on hold / given Business holiday for a specified period by any Public Sector Undertaking or Government Departments. The reasons for such action with details and the current status of such hold shall be clearly furnished to BHEL. If no such details are mentioned in the offer, it will be construed that the bidder is not under any such hold. However, at a later date if it comes to the notice of BHEL about any such hold under enforcement, BHEL reserves the right to reject the offer at any point of time and also under any stage of the finalization of the tender. Such bidders will not be permitted to participate in the further tender proceedings and will be communicated suitably.

**22. Issue of Materials:**

- a. The raw materials are to be collected from BHEL by the vendor at his cost  
b. ~~The raw materials will be supplied at your works at our cost.~~

**23. Bank Guarantee:**

You will have to execute a Bank guarantee for the value of **Rs.50,000/- (Fifty thousand rupees)** towards satisfactory performance of the order and for the safe custody of the raw materials. The guarantee shall be executed on a Non-judicial stamp paper of value Rs.100/- and shall be kept valid for a period of one year against the orders already placed and to be placed by BHEL. All bank charges will be to the supplier's account.

In case any bidder does not accept for submission of Bank guarantee, their offer is likely to be rejected. However, in case of any vendor having a valid Bank Guarantee executed for any of the previous ATP/Sub-contracting orders, the same shall be used for this tender provided the existing BG value is not less than the requirement (cumulative value including the POs for which the deliveries are not completed) specified above.

**24. Manufacturing of Components:**

- a. The items are to be strictly manufactured as per Scope and drawing / OPS.  
b. Attestation procedure is to be followed wherever required as per Annexure-B

**25. Inspection of Components:**

- a. Stage or final Inspection of the components will be done by BHEL/Customer Inspection agencies for which a register for dimensional report shall be maintained at your works and you have to provide all the required facilities Free of Cost. The Inspection results should be given in the format specified by QC/BHEL and necessary stage clearances should be obtained as mentioned in OPS.  
b. The items requiring first off clearance for bulk production shall be offered for Inspection immediately after sample pieces have been completed. Only on getting the approval from our Inspector and authorised representative in writing, further work on bulk production is to be started.  
c. In case of partial or full raw material supply by BHEL for rejection due to our raw materials defect, we will allow proportionate payment to the extent of machining carried out.

**26. Painting & Packing of components:**

- a. All the machined surfaces or threaded surfaces are to be carefully packed to avoid any damage during transportation

- b. Supplier's code number allotted by us should be punched and encircled with white paint on the finished components wherever possible. In case of small items, metal tags shall be prepared for the same.
- c. Any deviation from the scope of machining shall be suitably painted on the component at the appropriate place.
- d. Wherever our work orders specified in the Purchase order, the details of Work Order Number, Du-Part Number, Quantity Numbers and weight in Kgs., apart from the IR. No., Should be painted in white paint on any prominent surface of the component or on a metal tag of size 100x175 mm for smaller items, initially applied with Red oxide primer to IS2074 and further applied with a coat of Varnish to avoid peeling off the paint.

**27. Accountability of raw materials:**

Balance of raw materials will be accounted on completion of the order. Balance materials will have to be returned by you to BHEL Stores. ~~Turnings and borings / wastages are to be returned to BHEL Stores.~~

~~Turnings and borings / wastages need not be returned to our Stores. You may give due Credit to the value of the same in your quotation and accordingly quote.~~

**28. Delivery of Components:**

- a. The finished goods should be delivered to BHEL/Trichy by the vendor at his own cost
- b. The Delivery challan should be prepared for each Purchase order / Work order separately as per our Proforma or online through B2B (Vendor information system)
- c. The consignment should accompany sufficient copies of online IRs & DCs as mentioned in the B2B (Vendor information system)
- d. The rejected items due to material defect are to be despatched by the vendor to BHEL on "Freight to pay basis" through any of our approved transport carrier along with 3 copies of PDO, one copy of IR and 4 copies of Delivery challan.
- e. The rejected items due to faulty workmanship at vendors end are to be delivered to BHEL at his own cost

**29. Payment:**

Payment for ~~100%~~ 90% will be made after 45 days from the date of receipt of finished goods and against the Inspection report (IR) (when the finished items are supplied whether partially or fully to BHEL) supported by:

- a) Two copies of your delivery challan acknowledge by our Stores / Shop
- b) Material accountal Statement for BHEL supplied material / FIM
- c) Invoice of three copies, addressed to DGM/Finance and routed through AGM/SC/ATP
- d) Balance 10% last payment shall be made only on completion of the order after duly accounting for rejections, short supplies (if any) and return or raw materials.
- e) Payment of proportionate machining charges for the rejected pieces due to material defect will be made against your Invoices in duplicate supported by 2 copies of IR. & Delivery challan acknowledged by our stores.

**30. LD Clause:**

Liquidated damages shall be 0.5% of the total order value per week or part thereof subject to a maximum of 10% of the total order value.

For staggered delivery schedule, LD shall be 0.5% of the undelivered portion per week of delay or part thereof subject to a maximum of 10% of the total order value.

Waiver of LD may be considered under special circumstances based on the written request from the vendor.

**31. Return of Documents:**

All the documents of BHEL including drawing/approved procedures made available to the vendors should be kept in **strict confidence** and under no circumstance be made available to others or allow others to make use of them. Such documents shall be returned to us on demand after completion. This secrecy clause is binding on the employees of the fabricators also. Any contravention will be subjected to legal action, besides suspending business with BHEL.

32. Any dispute arising out of or in connection with this Agreement shall be finally settled by binding arbitration in accordance with the Arbitration and Conciliation Act, 1996 as may be amended from time to time. Executive Director / BHEL, Trichy – 620 014 or his authorized representative shall be the Sole Arbitrator and his decision shall be final and binding on both the parties. The place of arbitration shall be Tiruchirapalli, and the language shall be English. The courts at Tiruchirapalli shall have exclusive jurisdiction on any dispute arising out of or in connection with this Agreement, if intervention of court is warranted, subject to the arbitration provided above.

A handwritten signature in blue ink, appearing to be 'S. Arumuga Raja', is written over a diagonal line. Below the signature, the date '17.08.2017' is written in blue ink.

Senior Engineer  
Sub-Contracting/ATP  
**S. ARUMUGA RAJA**  
Sr. Engineer  
Sub Contracting / ATP  
BHEL, TRICHY - 620 014.



# BHARAT HEAVY ELECTRICALS LIMITED

TIRUCHIRAPPALLI - 620 014

## ADVANCED TECHNOLOGY PRODUCTS / SUB CONTRACTING

### ANNEXURE - B

#### IMPORTANT POINTS TO BE NOTED WHILE PROCESSING THE ATTESTED MATERIAL

- 01 Raw material should not be taken up for machining/processing without attestation card.
- 02 The details given in the Attestation card should tally with the details punched on the raw material along with Inspector's seal.
- 03 Before gas cutting/hacksaw cutting/machining, attestation particulars are to be transferred to individual pieces along with BHEL Inspector's seal.
- 04 BHEL Inspector alone is authorised to put his Seal on attested material.
- 05 The following details should be punched each component. If the components are too small, the details may be punched on a Metal Tag and tied after consulting our Inspector.
  - A) Attestation card numbers.
  - B) Material specification.
  - C) Melt number
  - D) BHEL's Inspector's Seal.
  - E) Firm code number.
- 06 Before taking up the raw material for processing, clearance is to be obtained in writing from our Inspector.
- 07 If any attestation particulars are removed during machining the same is to be transferred immediately on the machined area along with our Inspector's Seal.
- 08 Before punching, if it is not a machined area, the same is to be thoroughly cleaned by grinding, Sand blasting or at-least by wire brushing. At no circumstances, the attestation shall be made on mill or heat treatment scale.
- 09 Use only 3mm letter and number punch. The punching depth shall be uniform and legible.
- 10 The attestation details are to be clearly bordered with yellow paint. Bordering is to be done only after applying rust preventive oil.
- 11 Attestation card is to be sent to Stores along with despatch documents. If any part supply is made, a true copy of the attestation card duly signed by our Inspector is to be sent along with the despatch documents. In such case, the last consignment is to be despatched with original attestation card.
- 12 All useable materials and bits are to be returned to our stores bearing attestation details with our Inspector's Seal.
- 13 Before dispatch Subcontractor should ensure that all the above points are followed without fail and ensure that the attestation details punched are correct.

  
17-08-2017  
**SARUMUGA RAJA**  
Sr. Engineer  
Sub Contracting / ATP  
BHEL, TRICHY - 620 014.

Senior Engineer  
Subcontracting / ATP

**TECHNO-COMMERCIAL BID FOR 627004E dated 17.08.2017**  
**ANNEXURE - C**

PRE-QUALIFICATION CRITERIA (TECHNICAL REQUIREMENTS)			
SL.NO.	DESCRIPTION	BHEL REQUIREMENTS	VENDOR CONFIRMATION / DEVIATION
01	EXPERIENCE IN Waterjet cutting, Die punching, Wire cutting OR SIMILAR TECHNIQUES	Only those vendors who have similar experience in doing these type of works should quote. <ul style="list-style-type: none"> <li>• Proof shall be submitted in the form of recent (2014-2017) Purchase order or in any other form.</li> <li>• BHEL reserves the right to verify the information provided by vendor. In case the information furnished by vendor is found to be false / incorrect, the offer /P.O shall be rejected.</li> </ul>	
02	COMPLIANCE WITH THE PROCEDURE	The vendor should specify the method adopted for fabrication to ensure compliance with the requirements of procedure.	
03	EQUIPMENTS/CHEMICALS TO BE USED	NA	
04	TRIALS (TEST COUPONS)	NA	
05	PROCESS REQUIREMENT	NA.	
06	TESTS & REPORTS	NA	

**NOTES :**

1. The Vendor shall attach annexures and provide detailed explanation wherever necessary.
2. Only those vendors who are meeting the pre-qualification criteria shall be considered for further tender processes.

  
 17.08.2017  
**S. ARUMUGA RAJA**  
 Sr. Engineer  
 Sub Contracting / ATP  
 BHEL, TRICHY - 620 014.

**COMMERCIAL TERMS & CONDITIONS**

SL.NO.	DESCRIPTION	BHEL REQUIREMENTS	VENDOR CONFIRMATION / DEVIATION
01	VALIDITY	Validity of the offer shall be minimum 1 year from the date of tender opening	
02	FREIGHTAGE (Consider transportation cost and quote accordingly; need not be separately specified in the quotation)		
	i) RAW MATERIAL	Material to be collected from BHEL, Trichy	
	ii) FINISHED COMPONENTS	Finished items in one lot to be properly packed and delivered to BHEL, Trichy within 60 days from date of material issue	
03	TAXES & DUTIES	Refer point 11 of Annexure-A	
04	PAYMENT TERMS	Refer point 29 of Annexure-A	
05	LIQUIDATED DAMAGES	Refer point 30 of Annexure-A	
06	BANK GUARANTEE	You have to execute a bank guarantee for Rs. 50,000/- before material collection	
07	DELIVERY SCHEDULE	Full lot (1872 No.) Within 60 days from the date of material collection	
08	RISK PURCHASE CLAUSE	Refer point 17 of Annexure-A	
09	OTHER TERMS(IF ANY)	Packing and extra care shall be taken during transportation and handling by the vendor.	



  
 17.08.2017

Authorised Signatory with Seal  
**S. ARUMUGA RAJA**  
 Sr. Engineer  
 Sub Contracting / ATP  
 BHEL, TRICHY - 620 014.

**ANNEXURE - N (For NEW VENDORS only)**

SI No	Details	Document submission
1	Nature of ownership & relevant documents (Proprietorship-Professional Tax Regn & Municipal Regn; Partnership firm – Partnership Deed; Co-operative society – Society rules & bye laws ; Private/Limited Company – memorandum & Articles of Association)	
2	Product or Service range & facilities: <ul style="list-style-type: none"> <li>List down the product range &amp; specification details.</li> <li>List of Manufacturing facilities/equipment's (including material handling facility)</li> </ul>	
3	Licence details of the factory	
4	<ul style="list-style-type: none"> <li>Permanent Account No</li> <li>GST registration number</li> <li>Regn number of category as per MSMED Act (If applicable)</li> </ul>	
5	If registered with any other BHEL unit <ul style="list-style-type: none"> <li>Letter of registration with BHEL unit (If applicable)</li> <li>Proof of successfully executed or executing purchase orders</li> </ul>	
6	Accreditation certificate for ISO:9001 / TOC of Quality System manual / ISO:14000 / OHSAS ISO 18000 (If applicable)	
7	Balance Sheet for the last three years along with the audit report	
8	EXPERIENCE IN ELECTRO-POLISHING OR SIMILAR TYPE OF WORK (All the new vendors should enclose a Purchase Order copy against their previous experience)	

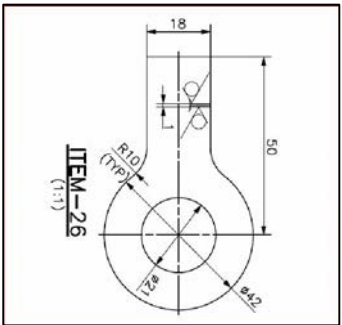
  
 17.08.2017  
**S. ARUMUGA RAJA**  
 Sr. Engineer  
 Sub Contracting / ATP  
 BHEL, TRICHY - 620 014.



Item: SI.No.01 - Washer-21  
 W.O:D135-001-1-93-130  
 Part No.:0226

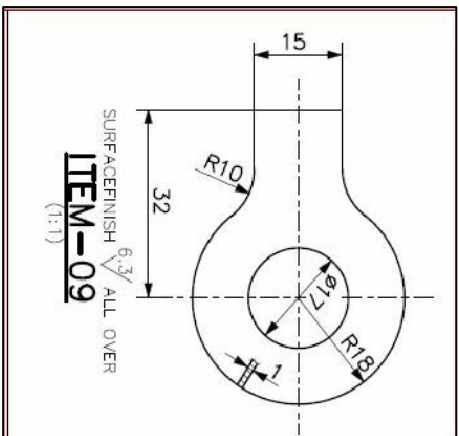

Item: SI.No.02- Lock Washer-17  
 W.O:D135-001-1-93-170  
 Part No.:0109

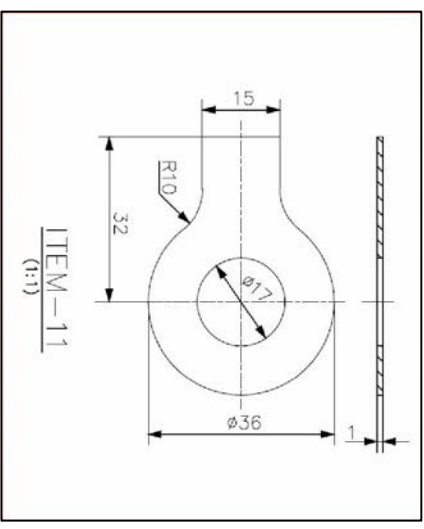

Item: SI.No.03 - Lock Washer  
 W.O:D135-001-1-93-112  
 Part No.:0111

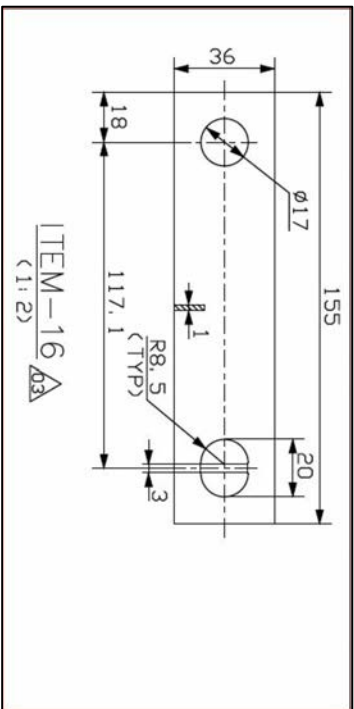

Item: SI.No.04 - Lock Plate  
 W.O:D135-001-1-93-129  
 Part No.:0108

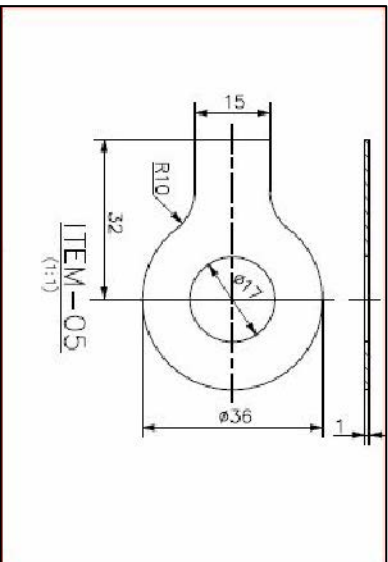

Item: SI.No.05 - Lock Washer  
 W.O:D135-001-1-93-129  
 Part No.:0105

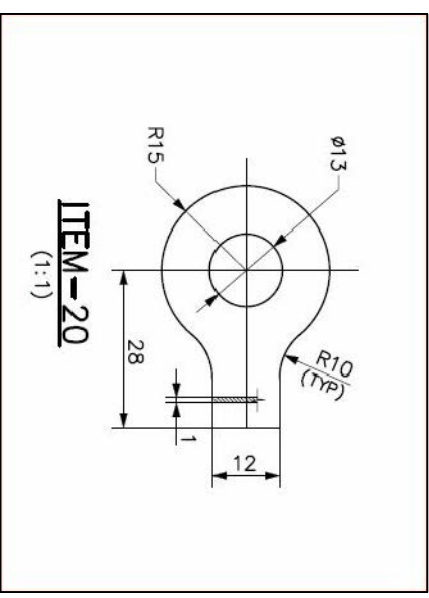

Item: SI.No.06 - Tab Washer  
 W.O:D135-001-1-93-128  
 Part No.:0120

**SKETCH-A**