



Tender Enquiry No. B/4011/2022/2607/V1 for the requirement of Electro Hydraulic Actuator for Talcher project

LIST OF ENCLOSURES

	<u>Document</u>	<u>Number of pages</u>
1.	MATERIAL DETAILS & INSTRUCTION TO BIDDERS	06
2.	PRE-QUALIFICATION REQUIREMENT	04
3.	A BRIEF WRITE UP ON ELECTRO HYDRAULIC ACTUATORS STEAM TURBINE VALVES	07
4.	BUYER SPECIFIC TERMS & COND SPECIAL CONDITIONS OF TENDER	09
5.	LIST OF BHEL CONSORTIUM BANK	01
6.	CERTIFICATE BY CHARTED ACCOUNTANT FOR MSE SUPPLIERS	01
7.	GENERAL INSTRUCTIONS & STANDARD TERMS & CONDITIONS (GISTC) REV.06	13
8.	MADE IN INDIA DECLARATION FORMAT	01
9.	BHEL STANDARD PBG FORMAT	02
10.	INTEGRITY PACT	05
11.	NDA	08
12.	BHEL STANDARD QP FORMAT	01
	TOTAL PAGES	58

Sachin Gupta (Engineer/PPX-BOI)
Email: gupta.sachin@bhel.in
Ph. 01334-281690

Pankaj Kumar (Manager/ PPX-BOI)
Email: subgpankaj@bhel.in
Ph. 01334- 281690



PPX-BOI DEPARTMENT
BHARAT HEAVY ELECTRICALS LIMITED
HEEP: HARDWAR-249 403 (Uttarakhand)
FAX: +91 1334 226084/226462
TEL: +91 1334 28 4269/1690

Enquiry No.: B/4011/2022/2607V/1
Item : EHA of Turbine Valve
Project : 2x660 MW Talchar

INSTRUCTION TO BIDDERS AND SPECIAL TERMS OF THE ENQUIRY

1. SCOPE OF ENQUIRY

Please note that this tender enquiry has been issued through BHEL's e-procurement portal developed by NIC (<https://eprocurebhel.co.in/>), hence PAPER BID or BID THROUGH e-MAIL SHALL NOT BE ENTERTAINED FOR THIS TENDER. Please upload your e-bid in BHEL's e-procurement portal developed by NIC (<https://eprocurebhel.co.in/>).

2. PROJECT INFORMATION

1.Project Name	2x 660 MW MW Talchar STPP
Consignee Address	NTPC LIMITED, TALCHER TPP, STAGE-III 2X660MW PO TALCHER, DISTT- ANGUL STATE OF ODISHA, PIN 759101
Tax Structure	GST Extra
Pls. note that the comparison would be done as per the applicable taxes and duties on the date of opening of Price Bid. Please note: Price to be quoted for Sets through prescribed BOQ format & upload through NIC portal..	

3. Brief Description of the requirement (For details refer price checklist)

Sl. No.	Project	Material Code	Item Description	Total Quantity	Delivery Schedule
1.	Talchar Unit-1 Project	W90311400230 DRG: 31140030600 VAR00 REV: 00	ELECTRO HYDRAULIC ACTUATORS OF TURBINE VLVE	01 Set	25.02.2025
2.	Talchar Unit-2 Project	W90311400230 DRG: 31140030600 VAR00 REV: 00	ELECTRO HYDRAULIC ACTUATORS OF TURBINE VLVE	01 Set	25.06.2025
3.	Talchar Project	W90311400140 DRG: 41140056502 VAR00 REV: 02	COMMISSIONING SPARE PARTS FOR ELECTRO HYDRAULIC ACTUATORS OF TURBINE VALVES	01 Set	25.02.2025
4.	Talchar Project	W99311401102 DRG: 31140030611 REV: 00	MANDATORY SPARES FOR EHA OF TURBINE VALVES	01 Set	25.08.2025

4. EARNEST MONEY DEPOSIT (EMD) :

Interested bidders must submit their offer along with the following Earnest Money Deposit (EMD) in a separate sealed envelope:

Details	Amount In INR	
EMD	INR 2,00,000/- (INR Two Lac or equivalent currency)	Refundable



PPX-BOI DEPARTMENT
BHARAT HEAVY ELECTRICALS LIMITED
HEEP: HARDWAR-249 403 (Uttarakhand)
FAX: +91 1334 226084/226462
TEL: +91 1334 28 4269/1690

Enquiry No.: B/4011/2022/2607V/1
Item : EHA of Turbine Valve
Project : 2x660 MW Talchar

4.1 The EMD should be submitted in the form of demand draft / Pay Order/ cash (as permissible under income tax act). The Drafts shall be drawn in favor of “*BHEL Hardwar*”. In case of foreign bidders, E- payment is also acceptable. For E-Payment, the RTGS details are as mentioned below:

Bank Details	SWIFT Details of bank	Contact Details of Banker
STATE BANK OF INDIA RANIPUR BRANCH, OPP: BHEL MAIN GATE, SECTOR-5, RANIPUR, HARIDWAR, UTTRAKHAND, INDIA PIN CODE : 249403	SWIFT NO : SBININBB225 CC ACCOUNT NO : 10667995458 IFSC CODE : SBIN0000586	Name: Sh. Sudhir Sharma Design: Chief Manager (IBD) Contact No. +91 1334 224201 +91 1334 226125 Fax: +91 1334 226512

4.2 The suppliers who are already registered in PMD (product Material Directory) of BHEL, HEEP Haridwar for supply of this item are exempted from submission of EMD.

4.3 All Central/State – PSUs/ Government Departments/ MSE Suppliers are exempted from submission of EMD. Micro and Small Enterprises (Registered under SSI, NSIC, Khadi Board, DIC etc.) are also exempted from submission of EMD.

“MSE Suppliers can avail the intended benefits only if they submit UDYAM certificate/UAM along with the offer, attested copies of either EM II certificate having deemed validity (five years from the date of issue of acknowledgement in EM II) or valid NSIC certificate or EM II certificate along with attested copy of a CA certificate (Format enclosed at annexure-1 where deemed validity of EM II certificate of five years has expired) applicable for the relevant financial year (latest audited). Date to be reckoned for determining the deemed validity will be the date of bid opening (Part 1 in case of two part bid). Non-submission of such documents will lead to consideration of their bid at par with other bidders. No benefit shall be applicable for this enquiry if any deficiency in the above required documents is found or the requisite documents are not submitted before price bid opening. If the tender is to be submitted through e-procurement portal, then the above require document are to be uploaded on the portal. Documents should be notarized or attested by a Gazette officer.”

4.4 Bids should be accompanied with requisite EMD. BHEL reserve the right to reject the offer not accompanied by requisite/inadequate EMD.

4.5 The bidder whose bid is technically not accepted will be informed & EMD wherever submitted shall be returned after the finalization of the contract. EMD shall be forfeited in the event of bidder opting out after tender opening within the validity of its offer.

5. PRE-QUALIFICATION REQUIREMENT (PQR);

Pre-Qualification requirement is mentioned in Annexure-PQR. Kindly ensure submission of documents in support of PQR(As applicable). Offer submitted by bidders will be scrutinized with respect to pre-qualification requirement first. Technical offer of the bidders not meeting Pre-qualification requirement will not be scrutinized.

Important Note: Bidders should ensure completeness and correctness of all supporting documents of PQR along with their offer. Not more than 30 days (After Opening of Techno-commercial offers) will be allowed to bidders for completing PQR documents. PQR review will be closed within 30 days of opening of techno-commercial Bids. Offers of Bidder / Bidders, who do not meet PQR i.e. do not complete the PQR documentation within 30 days of opening of techno-commercial bid, may be ignored and no-further correspondence may be entertained thereafter.



PPX-BOI DEPARTMENT
BHARAT HEAVY ELECTRICALS LIMITED
HEEP: HARDWAR-249 403 (Uttarakhand)
FAX: +91 1334 226084/226462
TEL: +91 1334 28 4269/1690

Enquiry No.: B/4011/2022/2607V/1
Item : EHA of Turbine Valve
Project : 2x660 MW Talchar

6. TECHNICAL SPECIFICATIONS:

The OEM manufacturer meeting pre-qualification requirement and having capability for supplying EHA may seek complete technical specifications from BHEL in Soft Copy. For seeking “technical specifications” potential suppliers shall submit following documents:

- **Non- Disclosure agreement (Duly signed and stamped at each page by original equipment manufacturer)**

The request for “technical specifications” with above documents should reach BHEL-Haridwar within 01 week from the date of issuing the tender notification. The technical documents will be provided with 07 days of receipt of request and above mentioned documents. All requests shall be addressed to the contact detail mentioned in clause no. 16 of this NIT.

7. SUBMISSION OF OFFER-

7.1 Please note that this tender enquiry has been issued through BHEL’s e-procurement portal developed by NIC

(<https://eprocurebhel.co.in/>), hence PAPER BID or BID THROUGH e-mail SHALL NOT BE ENTERTAINED FOR THIS

TENDER. Please upload your bid in BHEL’s e-procurement portal developed by NIC (<https://eprocurebhel.co.in/>). Please

registered your firm on <https://eprocurebhel.co.in/> to participate in tenders floated by BHEL. In case of any difficulty faced while registering on BHEL’s e-Procurement portal developed by NIC, queries may be addressed to 0120-4001002, 0120-4001005 and 0120-6277787; email: support-eproc@nic.in. These details are also available on ‘Contact Us’ page of the portal.

7.2 Only English version or bilingual with one language as English, of all documents would be valid & binding.

7.3 Bidders are advised to read all the tender documents carefully. Any submission of tender by the bidder shall be deemed to have been done after careful study and examination of the tender documents and with full understanding of the implications thereof. The specifications/ Technical Requirements and terms & conditions shall be deemed to have been accepted unless otherwise specifically commented upon in ‘Deviation’ sheets by the bidder in his offer. Non-compliance with any of the requirements and instructions in the Tender Enquiry may result in rejection of the offer.

7.4 Name of vendor’s dealing person with Contact No(s), Email ID and Address of correspondence shall be provided in the bid.

7.5 Tenders are to be uploaded on BHEL e-procurement portal developed by NIC (<https://eprocurebhel.co.in/>) in Two Parts and Part-I (Techno-Commercial Bid along with PQR, as detailed below) will be opened first. The offers are to be uploaded on or before the last date of submission of offer, as detailed on BHEL e-procurement portal for the tender:

7.6 This is two-part tender (Part1 & Part2 bid shall be submitted as below)-

For part 1 (Technocommercial bid): all technical & commercial document of enquiry shall be submitted.

For part 2 (price): price shall be uploaded in the prescribed BOQ format as enclosed.

[A] PART-I BID: PRE-QUALIFICATION REQUIREMENT (PQR) & TECHNO-COMMERCIAL BID

Following documents are an integral part of this tender enquiry and endorsed copies of these documents (duly signed and stamped on each page, as a token of acceptance) and reply for each clause of Annexure-A are to be necessarily submitted along with the ‘Techno-Commercial Bid’ (Part-I bid).

All these following documents shall be uploaded in the “Techno-commercial bid level” on BHEL e-procurement portal developed by NIC (<https://eprocurebhel.co.in/>). PAPER BID or BID THROUGH e-MAIL SHALL NOT BE ENTERTAINED FOR THIS TENDER ENQUIRY.



PPX-BOI DEPARTMENT
BHARAT HEAVY ELECTRICALS LIMITED
HEEP: HARDWAR-249 403 (Uttarakhand)
FAX: +91 1334 226084/226462
TEL: +91 1334 28 4269/1690

Enquiry No.: B/4011/2022/2607V/1
Item : EHA of Turbine Valve
Project : 2x660 MW Talchar

- Proof of EMD submission details must be uploaded on the e-procurement portal.
 - Please submit duly signed & stamped copy (each page) of the Pre- Qualification Requirements (PQR) as enclosed with proper filled information and related supporting documents as mentioned.
 - Bidders are required to furnish requisite details in the formats specified in bidding documents for meeting the stipulated Pre-Qualification Requirements (PQR) along with all supporting documents like copies of End User Certificates, Unpriced copy of Purchase Orders and Contract Agreements etc.
 - Complete Technical offer with relevant drawings/ documents etc.
 - Please submit duly signed & Stamped copy of replica of Price Bid (without prices) showing ‘quoted’ in place of price.
 - Please submit duly signed & Stamped copy (each page) of duly filled “Additional Terms and conditions of tender enquiry (Annexure-A)” and its clause wise supporting documents where required.
 - Please submit duly signed & stamped copy (each page) of GISTC as provided along with Tender enquiry.
 - Please submit duly signed & stamped copy (each page) of BHEL purchase & technical specification documents enclosed.
 - Please submit Endorser copy of QAP.
 - Please submit duly signed & stamped copy (each page) of “Instructions to bidder”
 - Commercial Terms & Conditions.
- i. Deviations if any are to be listed out separately. Please note that in case no- deviation sheet is received along with offer, it will be presumed that all terms and conditions mentioned in “INSTRUCTION TO BIDDERS, additional Terms & conditions of Tender enquiry as (Annexure-A) and “GISTC (General Instructions and Standard Terms & Conditions against Tender Enquiry)” shall be acceptable to you and your offer will be processed accordingly. Acceptance of such technical deviations would be at the discretion of BHEL.

[B] PART-II BID PRICE-BID) :
BOQ

Prescribed BOQ shall be downloaded from online tender documents and after filling the relevant columns the same shall be uploaded by bidders. Please note that file name shall not be changed.

- 7.7 e- price bid shall be opened as per schedule given after technical evaluation.
- 7.8 Online Part-I bid (Techno-Commercial bid along with PQR) will be opened on Due Date and time specified in the online tender enquiry, or extension thereof. Incomplete offers are liable to be rejected.
- 7.9 Techno-Commercial offer of only those bidders shall be evaluated who meet the Pre-Qualification Requirements mentioned in our Enquiry and who have submitted the EMD as stipulated in clause 3 above.
- 7.10 After opening of the online techno-commercial offer, the offers would be evaluated by BHEL.
- 7.11 After finalization of Techno-Commercial evaluation, offers of qualified bidders (techno-commercial offer) shall be considered for Price Bid opening. After opening of online price bid BHEL SHALL BE RESORTING TO REVERSE AUCTION (RA) (GUIDELINES AS AVAILABLE ON www.bhel.com) FOR THIS TENDER. RA SHALL BE CONDUCTED AMONG ALL THE TECHNO-COMMERCIALY QUALIFIED BIDDERS AS PER GUIDELINES FOR REVERSE AUCTION-2021.
- 7.12 BHEL prefers to deal directly with the principal manufacturers/OEM. However, if the OEM/ Principal insists on engaging the services of an agent, the same can be allowed only thru a tender specific authorization letter issued by the principal/OEM. The acceptance of any such offer would be at the discretion of BHEL.

As per directives of CENTRAL VIGILANCE COMMISSION, GOVERNMENT OF INDIA, one agent can not represent two or more suppliers or quote on their behalf in a particular tender. If so



PPX-BOI DEPARTMENT
BHARAT HEAVY ELECTRICALS LIMITED
HEEP: HARDWAR-249 403 (Uttarakhand)
FAX: +91 1334 226084/226462
TEL: +91 1334 28 4269/1690

Enquiry No.: B/4011/2022/2607V/1
Item : EHA of Turbine Valve
Project : 2x660 MW Talchar

found at any stage, BHEL Hardwar is likely to cancel Enquiries / POs to such suppliers. Further, such Indian Agent is likely to be de-listed (Black listed for business from BHEL).

Moreover, either the agent could bid on behalf of the manufacturer/ supplier or the manufacturer/ supplier could bid directly but not both. In case bids are received from both the manufacturer/ supplier and the agent, bid received from the agent shall be ignored.

7.13. Vendors operating from BHEL quarters, unauthorized colonies on BHEL Land and Dharamshalas/ Hotels shall not be considered, hence such vendors need not apply.

8. **MAKE IN INDIA :**

This is domestic open tender enquiry and only class -1 and class-II local suppliers are eligible to participate in this tender enquiry under compliance of PPP-MII Order No. P-45021/ 2/ 2017-PP (BE-II) dtd. 04/06/2020 of Govt of India. Purchase preference to class-1 local supplier over class2 supplier shall be applicable as per PPP-MII Order No. P45021/ 2/ 2017-PP (BE-II) dtd. 04/06/2020 of Govt of India. Make in India deceleration certificate is enclosed. Suppliers are proposed to submit signed & stamp copy of the same along with their offer.

9. **Evaluation Criteria**

Evaluation shall be done project wise on total landed cost upto respective BHEL Project Site considering all material codes and services together.

10. **OFFER VALIDITY**

The offer is to be submitted with a validity of 180 days from the date of opening of techno-commercial offers. BHEL will reserve the right to reject the offer, quoting validity less than 180 days.

11. **PRE BID CLARIFICATION/ PRE BID MEETING**

- Please note that as per BHEL's Policy, we cannot allow Price impact for the requirement / scope of supply, which is a part of specifications of our tender enquiry. Hence please read all specification / documents thoroughly and submit your offer as per specifications of tender enquiry.
- In case of any confusion / non-clarity on any of the clause / requirement of specification, please clarify the same from BHEL before submission of offer. Pre-bid meeting can also be arranged on bidder's request for clarification of techno-commercial scope.
- No deviation & request regarding non-clarity / contradictory conditions / ambiguity of specifications would be entertained after opening of techno-commercial offers. Further no price impact would be allowed for the requirement which is already part of the specifications of the tender enquiry, after opening of techno-commercial offers.
- The prices are to be quoted on firm basis. BHEL will reserve the right to reject the offer of the vendors not quoting the prices on Firm basis.
- Bidders shall submit their techno-commercial queries within 10 days of floating the NIT. Clarifications would be arranged within next one week. Bidders may also request for pre-bid meeting for techno-commercial clarification within one weeks of floating the NIT.

12. **DEALING WITH BANNED SUPPLIERS/ CONTRACTORS IN BHEL**

Offers of the bidders, who are on the banned/hold list, and also the offers of the bidders who engage the services of the banned/hold firms, shall be rejected. The list of banned/hold firms is available on BHEL website www.bhel.com.

13. **RIGHT OF ACCEPTANCE**

- a) BHARAT HEAVY ELECTRICALS LIMITED HARIDWAR reserves the right to reject any or all the bids/quotations without assigning any reason thereof. BHEL also reserves the right to increase or decrease the tendered quantities. Bidders should be prepared to accept order for reduced quantity without any extra charges.
- b) Any discount/ revised offer submitted by a bidder on its own shall be accepted provided it is received on or before the due date and time of offer/bid submission (Part-I) if system allow. The



PPX-BOI DEPARTMENT
BHARAT HEAVY ELECTRICALS LIMITED
HEEP: HARDWAR-249 403 (Uttarakhand)
FAX: +91 1334 226084/226462
TEL: +91 1334 28 4269/1690

Enquiry No.: B/4011/2022/2607V/1
Item : EHA of Turbine Valve
Project : 2x660 MW Talchar

- discount shall be applied on pro- rata basis to all items unless specified otherwise by the bidder. Conditional discounts shall not be considered for evaluation of tenders.
- c) Unsolicited discounts/revised offers given after enquiry opening (i.e. Part-I bid opening) shall not be accepted.
- d) In case there is no change in the technical scope and/or specifications and/or commercial terms & conditions, the bidder/s shall not be allowed to change his/their price bids after the due date (i.e. Part-I bid opening).
- e) In case of changes in scope and/or technical specification and/or commercial terms & conditions, having price implications, techno-commercially acceptable bidders shall be asked by BHEL (after freezing the scope, technical specifications and commercial terms & conditions) to submit the impact of such changes on their price bid. A cut-off date and time shall be given to all the techno-commercially acceptable bidders to submit the impact on their price bids.
- f) In the event of any bidder, after finalizing the technical specification & scope of supply, opting to revise and submit their latest price bid instead of submitting impact on their price bid asked by BHEL, then their latest price bid shall prevail. However, in such condition their original price bid will necessarily be opened.
- g) After technical & commercial examination of the offers received and clarifications obtained (if required), Part-II (Revised Price Bid/ Original Price Bid along with Price Impact and Discount, if any) shall be opened, for which the date and time shall be intimated to technically and commercially acceptable bidders in case of public opening. BHEL may opt to finalize the prices through Reverse Auction amongst technically and commercially acceptable bidders. BHEL reserves the right to open the earlier price bids, if any, submitted by the bidder(s), if required.
- h) No correspondence shall be entertained from the tenderers after opening of Part-II (Price bid), except clarifications (if any) asked by BHEL in writing.

IMPORTANT NOTE;

INSTRUCTION TO BIDDERS & SPECIAL TERMS OF ENQUIRY are to be read and complied along with GISTC . A signed & stamped copy of these documents as a token of acceptance is to be submitted along with the offer. In the event of contradiction of terms and conditions mentioned, the order of preference shall be INSTRUCTION TO BIDDERS & SPECIAL TERMS OF ENQUIRY followed by GISTC (General Instructions and Standard Terms & Conditions against Tender Enquiry).

Deviations (if any) are to be listed separately in deviation sheet. Please note that in case, no- deviation sheet is received along with the offer, it will be considered that all terms and conditions mentioned in above documents are acceptable to the bidder and your offer will be processed accordingly.

PART-I (Techno-Commercial bid with PQR) will be opened on Due Date and time specified in the Enquiry, or extension thereof, in presence of bidders who may like to attend. Incomplete offers are liable to be rejected. All correspondence thereof, shall be addressed to the following persons:

Mr. Sachin Gupta
Designation: Engineer (PPX-BOI)
4th Floor, Main Administrative Building
HEEP, BHEL Hardwar- 249403
Uttarakhand, India
Email ID: gupta.sachin@bhel.in
Tel: +91 1334 28 1690

Mr. Pankaj Kumar
Designation: Manager(PPX-BOI)
4th Floor, Main Administrative Building
HEEP, BHEL Hardwar- 249403
Uttarakhand, India
Email ID: ssbgpankaj@bhel.in
Tel: +91 1334 28 1690

**Pre-qualification requirements (PQR) for "Electro-hydraulic actuators of Main Turbine valves" for Indent
no. 20222607**

Clause No.	Pre-Qualification Requirements	Vendor's Response
1.	The vendor should have the experience of Design, Manufacturing, Testing, Supply & Commissioning of Electro-hydraulic actuators of Main Turbine valves for Steam Turbines with parameters listed in points below (a to e). The vendor to confirm. <ul style="list-style-type: none"> a- MW rating of the Steam Turbine should be 660 MW or above; b- Quick closing time (Trip time) of Electro-hydraulic actuators should be 170 Mili second or less; c- Operational philosophy of Electro-hydraulic actuators should be "Oil pressure to open & Spring force to close"; d- Normal working pressure of control fluid in-side the Electro-hydraulic actuators should be 160 bar or above; e- Electro-hydraulic actuators should be operated from an independent Hydraulic power supply unit; 	
2.	The vendor to submit experience details of supplied Electro-hydraulic actuators as per Annexure-A (copy enclosed) complying the requirements mentioned at Sl. No. 1 above, for at least one power station having minimum one year of satisfactory running experience as on date of issuance of purchase enquiry.	
3.	The vendor should have the in-house testing facilities for testing (like stroke test, timing test, hydraulic test etc.) of Electro-hydraulic actuators. The vendor to confirm. Also furnish the supporting documents.	
4.	The vendor to furnish the following documents for our review for executed purchase orders referred against Sl. No.-2 above: <ul style="list-style-type: none"> a- Copy of Unpriced Purchase Order. The date of Purchase order shall not be older than 10 years from the date of issuance of BHEL purchase enquiry; b- Test reports of the Electro-hydraulic Actuators; c- Commissioning protocols of Electro-hydraulic Actuators at project site; d- Material acceptance certificate/ dispatch documents of Electro-hydraulic Actuators; e- Customer/End user certificate of min. one year of satisfactory operation of Electro-hydraulic Actuators. The date of issue of certificate shall not be older than 10 years from the date of issuance of BHEL purchase enquiry. For vendors who have supplied Electro-hydraulic actuators of Main Turbine valves (as per Sl. No.-1 & 2 above) earlier to BHEL, Haridwar may inform Purchase Order number only.	
5.	A Joint Venture/ Subsidiary Company/ Sister Company/ Collaborator Company formed for manufacturing and supply of Electro-hydraulic actuators in India can also be considered, provided that it has a valid collaboration or licensing agreement with a qualified original equipment manufacturer (OEM) who meets the qualification requirements stipulated at Sl. No. 1, 2, 3 & 4 above. Valid collaboration /licensing agreement should be in existence before the date of issuance of purchase enquiry & shall be maintained for a lock-in period of Ten (10) years from the date of issuance of purchase enquiry. Vendor to submit supporting documents in this regard.	
6.	In case the qualification is sought as per clause 5: <ul style="list-style-type: none"> a- The details of vendor shall be submitted as per Annexure-B & details of its collaborator (i.e. manufacturer of proven equipment as per clause-1, 2, 3 & 4) shall be submitted as per Annexure-A. b- The vendor should have established manufacturing and testing facilities at its works as per Collaborator/licensor's design, manufacturing and quality control system for such equipment duly certified by the Collaborator/licensor as on date of issuance of purchase enquiry. Evidence/Confirmation to be furnished from OEM. c- Collaborator/Licenser shall provide all design documents, manufacturing drawings and must provide technical and quality surveillance assistance and supervision during manufacturing, erection, testing & commissioning of equipment. Evidence/Confirmation to be furnished from OEM. Also Collaborator/licensor shall provide the required technical and service support during operation of Actuators, if needed. d- Collaborator/Licenser shall provide guarantee towards quality and workmanship of the product manufactured at India. Evidence/Confirmation to be furnished from OEM. e- Vendor to confirm to provide all design documents authored/vetted by its collaborator (who meets requirements mentioned at point 1, 2, 3 & 4 above) for review/approval by BHEL after placement of purchase order; f- Vendor to confirm that all major Casting, Forgings, Bought out items such as Solenoid valves, Servo valves etc. shall be procured from its Collaborator approved sub-vendor only. Collaborator approved sub vendor list is to be furnished to BHEL along with the offer. 	

Signature of authorized signatory.....

Note:-

- Against vendor's replies, BHEL reserves the right to ask for more information/documents/clarifications. Vendor's offer shall not be considered if vendor fails to furnish the document/information/clarifications as mentioned above or vendor doesn't meet the above acceptance criteria.
- A brief Write up on **Electro-hydraulic actuators for main turbine valves** is also enclosed as Annexure VI.

Manager (STE-TG)

Lakshmi
25/03/23

AGM (STE-TG, TB)

M. Bahar
25/03/23

AGM & Head (STE)

Harish
29.3.23

Annexure – A

Sl. No.		BHEL PQR requirement	Vendor's response
1.	Name of the station and its Location		*
2.	Client name and its address, Fax no. & Tel. No.		*
3.	Name, designation, e-mail id & Mobile no. of the responsible person in client's organization		*
4.	Purchase order No. & Date		*
5.	Name plate rating in MW of individual Steam turbine unit	≥ 660 MW	*
6.	Actual date of supply		*
7.	Date of Commissioning of Electro-hydraulic actuators		*
8.	Years of successful operation as on date of issuance of enquiry	1 years (Min.)	*
9.	Brief Scope of work		
10.	Designed by		*
11.	Manufactured by		*
12.	Working fluid (Mineral oil/Fire resistant fluid)		*
13.	Normal working pressure of control fluid	≥ 160 bar	*
14.	Operation philosophy	Oil pressure to open & Spring force to close	*
15.	Spring type		
16.	EHA's for turbine valves :		
16.1	HP Stop valve actuator:		
a)	Actuator piston diameter		
b)	Piston rod diameter		
c)	Damping stroke		
d)	Total actuator stroke, including over stroke		
e)	Actuator opening time		
f)	Actuator closing time (Trip time)	≤ 170 ±10% ms	*
g)	Spring size & no. of springs		
h)	Model no & make of EHA open/close (Pilot) valve		
i)	Model no. & make of EHA solenoid trip valve		
16.2	HP control valve actuator:		
a)	Actuator piston diameter		
b)	Piston rod diameter		
c)	Damping stroke		
d)	Total actuator stroke, including over stroke		
e)	Actuator opening time		
f)	Actuator closing time (Trip time)	≤ 170 ± 10% ms	*
g)	Spring size & no. of springs		
h)	Model no. & make of EHA Servo valve		
i)	Make and model no. of EHA solenoid trip valves		
16.3	IP stop valve actuator:		
a)	Actuator piston diameter		
b)	Piston rod diameter		
c)	Damping stroke		
d)	Total actuator stroke, including over stroke		
e)	Actuator opening time		
f)	Actuator closing time (Trip time)	≤ 170 ±10% ms	*
g)	Spring size & no. of springs		
h)	Model no & make of EHA open/close (Pilot) valve		
i)	Model no. & make of EHA solenoid trip valve		

Lakshmi

16.4	IP control valve actuator:		
a)	Actuator piston diameter		
b)	Piston rod diameter		
c)	Damping stroke		
d)	Total actuator stroke, including over stroke		
e)	Actuator opening time		
f)	Actuator closing time (Trip time)	$\leq 170 \pm 10\% \text{ ms}$	*
g)	Spring size & no. of springs		
h)	Model no. & make of EHA Servo valve		;
i)	Make and model no. of EHA solenoid trip valves		
16.5	Overload control valve actuator (if applicable):		
a)	Actuator piston diameter		
b)	Piston rod diameter		
c)	Damping stroke		
d)	Total actuator stroke, including over stroke		
e)	Actuator opening time		
f)	Actuator closing time (Trip time)	$\leq 170 \pm 10\% \text{ ms}$	*
g)	Spring size & no. of springs		
h)	Model no. & make of EHA Servo valve		
i)	Make and model no. of EHA solenoid trip valves		

Note:

(i)- Vendor to fill the applicable data in the format given above.

(ii)- Further the data marked as * are to be **mandatorily** filled by the vendor.

Annexure-B

Detail of Indian JV /subsidiary company/ Sister Company/Collaborator Company proposed for manufacturing of Electro-hydraulic actuators as per clause no. 5 of Pre-qualification requirement			
SL. NO.	Item Description	BHEL Requirement	Applicable data
1	Name and address with telephone no. of the Indian JV /subsidiary company/ Sister Company/Collaborator Company proposed for manufacturing of Electro-hydraulic actuators .		
2	Name and address with telephone no. of the promoter of JV /subsidiary company/ Sister Company/Collaborator Company, who meets the requirement of clause 1,2,3&4 of Pre-qualification requirement.		
3	% of the equity held by the promoter(s).		
4	Collaboration /licensing agreement lock in period	Ten (10) years from the date of issuance of purchase enquiry	
5	M/s. (JV/subsidiary company/Sister Company/Collaborator Company) has a collaboration or valid licensing agreement with M/s..... (Promoter company) for design, Engineering, manufacturing & supply of Electro-hydraulic actuators .	The vendor to furnish valid collaboration/licensing agreement which should be in existence before the date of issuance of purchase enquiry & shall be maintained for a lock-in period of Ten (10) years from the date of date of issuance of purchase enquiry.	
6	The vendor to furnish commitment for lock in period as per requirement.	Confirmation to be provided by the vendor	

The vendor to submit documentary evidence in support of above requirements.

Signature of authorized signatory.....

Lakshmi



A BRIEF WRITE UP ON ELECTRO-HYDRAULIC ACTUATORS FOR MAIN STEAM VALVES FOR 660/800 MW RATING STEAM TURBINE SETS

Status:	Released
Protection class:	Confidential

Rev.	Date	Issue resp./ Modification	Office	Prepared by	Reviewed by
00	27.08.2016	First issue	STE, CIE	Lakhmi Singh (STE-TG) Nitin (CIE)	Rajeev Rawat (STE-TG) Sheetal Singh (CIE)

BHEL HARIDWAR

Transmittal, reproduction, dissemination and/or editing of this document as well as utilization of its contents and communication thereof to others without express authorization are prohibited. Offenders will be held liable for payment of damages. All rights created by patent grant or registration of a utility model or design patent are reserved.



A BRIEF WRITE UP ON ELECTRO-HYDRAULIC ACTUATORS FOR MAIN STEAM VALVES FOR 660/800 MW RATING STEAM TURBINE SETS

1 INTRODUCTION:

The steam turbine output is controlled by adjusting steam mass flow rate by turbine valves. **There are total 9 nos. turbine valves viz. 2 nos. HP stop valves, 2 nos. HP control valves, 2 nos. IP stop valves, 2 nos. IP control valves and 1 no. overload control valve.** These turbine valves are hydraulically actuated. In the case of a turbine trip, turbine valves interrupt the steam flow into the turbine instantly.

There is dedicated Electro-hydraulic actuator for each turbine stop and control valve. Hence **total 9 nos. actuators are envisaged.** All the actuators are operated with 160 bar high pressure fire resistant fluid supplied from centralized Hydraulic Power Supply Unit (HPSU).

Electro-hydraulic actuators mainly consists of Hydraulic pistons, Disc spring, Servo valves, Pilot valve, Trip solenoid valve, Cartridge valve, Check valves, Filter etc. Servo valve/Pilot valve transmit the electrical input signal of the turbine controller output into a hydraulic signal and amplify it, guide the control fluid flow to the hydraulic actuators so that the required steam flow rate can be regulated/stopped.

Cartridge valves mounted on the control blocks of actuators assemblies takes care that hydraulic actuators can close the steam valves within a very short time.

A typical cross section drg. of actuator is shown below.

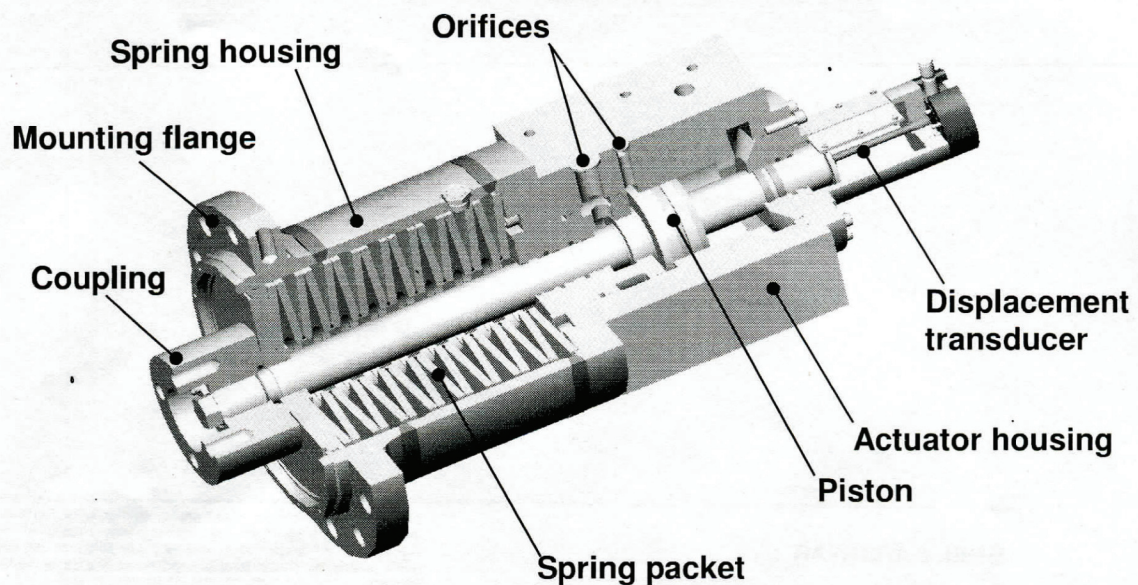



A BRIEF WRITE UP ON ELECTRO-HYDRAULIC ACTUATORS FOR MAIN STEAM VALVES FOR 660/800 MW RATING STEAM TURBINE SETS

2 STOP VALVE ACTUATOR (HP, IP):

The stop valve actuator is an Electro-Hydraulic Actuator with control fluid supply from HPSU. The actuator comprises an operating cylinder, control unit & valve position transmitter to monitor the opening and closing of the actuator/valve. Turbine stop valve is coupled with control piston of power cylinder. The control piston which is pressure loaded in opening direction and pressure relieved on the opposite side, moves in power cylinder. The closing force is supplied to the control piston by a cup – spring stack housed inside the actuator. The actuator is connected to the HPSU through control fluid supply and return lines. A filter along with D.P. switch is fitted in pressure line (upstream side) to prevent ingress of contamination from the pipe lines. A terminal box is also provided for wiring purpose.

2.1 CONTROL UNIT (MANIFOLD):

The control unit is mounted on the power cylinder and comprises of the Pilot valve, Trip solenoid valves, cartridge valves, check valves and orifices. All these control elements are connected via a control plate to the power cylinder through internal fluid ducts.

2.2 MODE OF OPERATION:

The trip solenoid valves (with double coils for redundancy) are energized with the help of output current signal from the controller for the opening of turbine stop valve. The fluid is fed to the power cylinder and pushes the piston in opening direction against the spring force. Stop valve is rapidly closed by de-energizing the trip solenoid valves, in that case the pressure over the discs of the logic cartridge valves is reduced, causing these valves to be opened by the pressure from the power cylinder being applied beneath the discs, thereby initiating the rapid closure of valve. Pilot valve remains in de-energized state during opening/rapid closing of the turbine stop valve. Pilot valve is energized only in case of normal closing of the turbine stop valves, keeping trip solenoid valves in energized state. The flow of oil to the actuator is realized through orifices. The sizing of these orifices is done based on the closing time of actuator. A leakage sensor is also provided in the leakage tray of actuator. It gives the signal to control room in case of leakage through actuator.

POSITION MONITORING:- 2 no. Position Transmitters and Limit Switches for Open and Close position of the valve are provided in each actuator.



A BRIEF WRITE UP ON ELECTRO-HYDRAULIC ACTUATORS FOR MAIN STEAM VALVES FOR 660/800 MW RATING STEAM TURBINE SETS

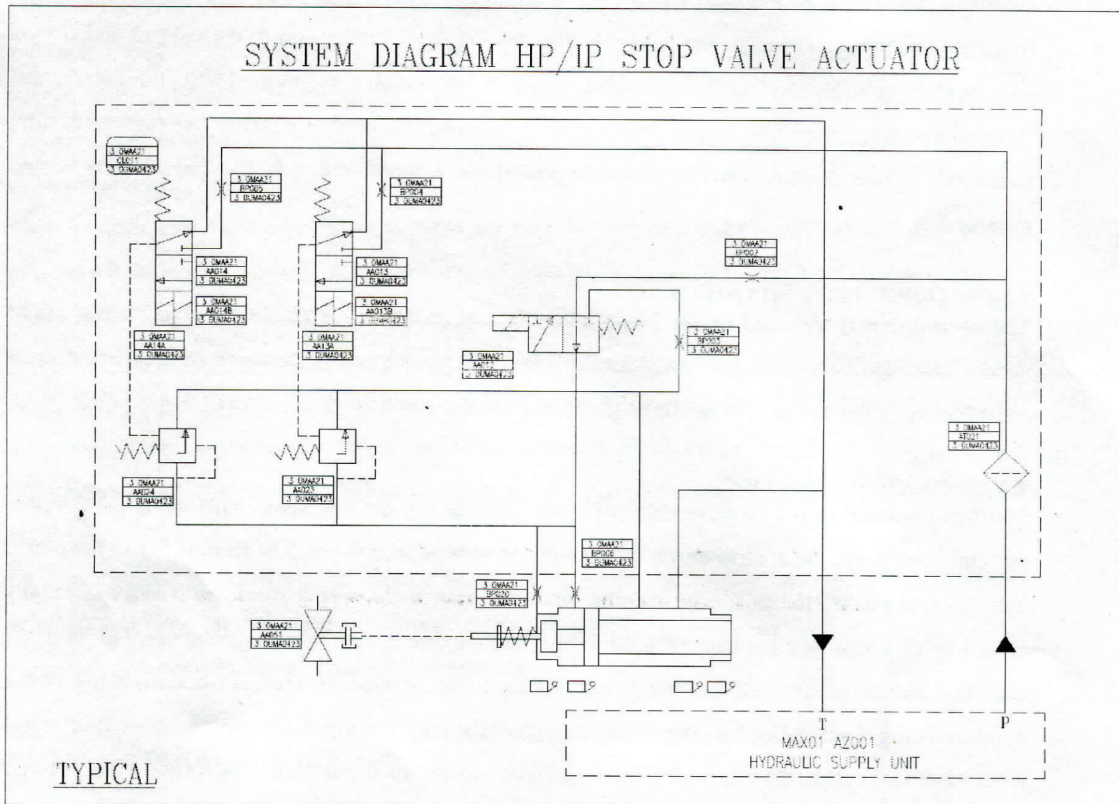



A BRIEF WRITE UP ON ELECTRO-HYDRAULIC ACTUATORS FOR MAIN STEAM VALVES FOR 660/800 MW RATING STEAM TURBINE SETS

3 CONTROL VALVE ACTUATOR:

The control valve actuator is an Electro-Hydraulic Actuator with control fluid supply from HPSU. The actuator comprises an operating cylinder, control unit and valve position transmitters. Turbine control valve is coupled with the control piston of power cylinder. The control piston which is pressure loaded in opening direction and pressure relieved on the opposite side, moves in power cylinder. The closing force is supplied to the control piston by a cup – spring stack housed inside the actuator. The actuator is connected to the HPSU through control fluid supply and return lines. A filter along with D.P. switch is fitted in pressure line (upstream side) to prevent ingress of contamination from the pipe lines. A terminal box is also provided for wiring purpose.

3.1 CONTROL UNIT (MANIFOLD):

The control unit comprises of servo valve, trip solenoid valves, cartridge valves, check valves and orifices. In addition a filter along with D.P. switch is also fitted to the pilot control of servo-valve. All these control elements are connected via a control plate to the power cylinder through internal fluid ducts.

3.2 MODE OF OPERATION:

The servo valve is a high grade continuously operating directional control valve with particularly good steady state and dynamic characteristics and high amplification. Servo valve which is controlled through a position controller, controls the flow of fluid to both sides of the control piston as a function of the output signal from the controller, thereby positioning the actuator. The analog position of the actuator is feedback to the controller by position transmitters. In the event of rapid closure, trip solenoid valves are de-energized and thus the pressure over the discs of the logic cartridge valves is reduced, causing these valves to be opened by the pressure from the power cylinder being applied beneath the discs, there by initiating the rapid closure of valve. The cartridge valves operated by the trip solenoid valves (with double coils for redundancy) are opened with minimum travel time and the piston chamber is connected to the drain. The flow of oil to the actuator is realized through orifices. The sizing of these orifices is done based on the closing time of actuators. A leakage sensor is also provided in the leakage tray of actuator. It gives the signal to control room in case of leakage through actuator.

POSITION MONITORING:- 2 no. Position Transmitters are provided in each actuator.



A BRIEF WRITE UP ON ELECTRO-HYDRAULIC ACTUATORS FOR MAIN STEAM VALVES FOR 660/800 MW RATING STEAM TURBINE SETS

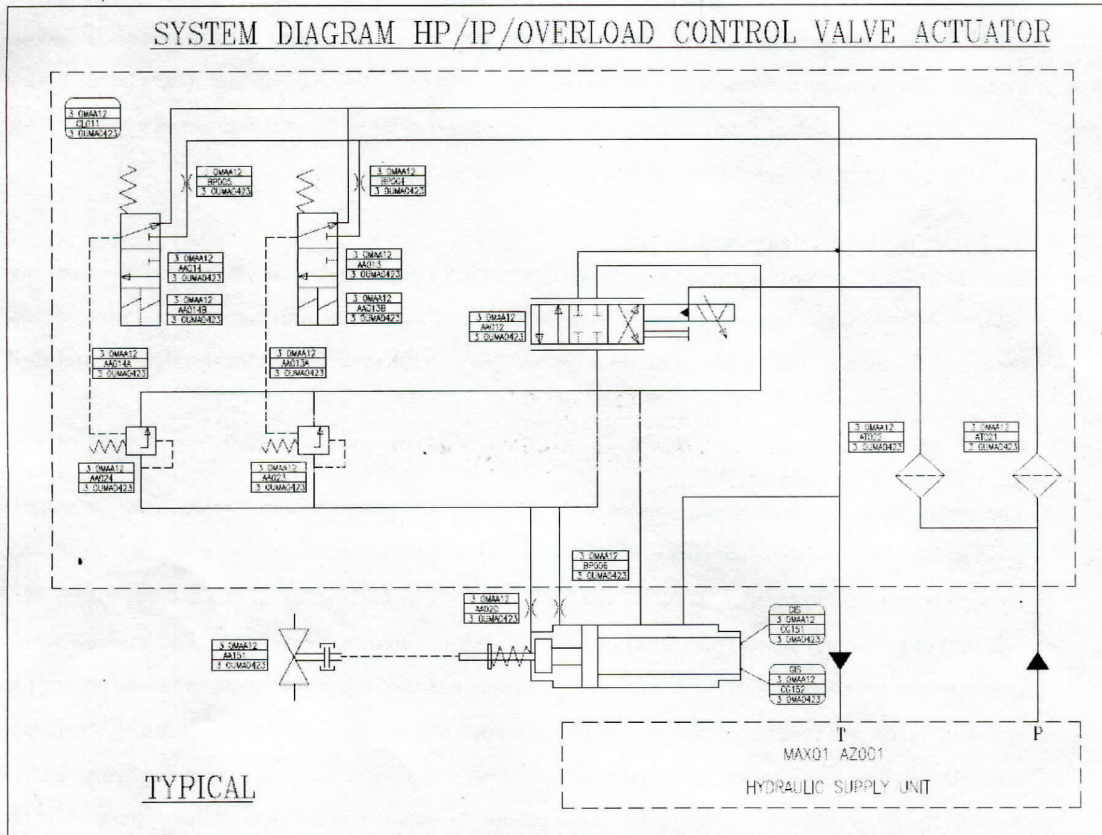



A BRIEF WRITE UP ON ELECTRO-HYDRAULIC ACTUATORS FOR MAIN STEAM VALVES FOR 660/800 MW RATING STEAM TURBINE SETS

4 SCOPE OF SUPPLY PER TG SET:

Sl. No.	Item description	Quantity per TG set
4.1	ELECTRO-HYDRAULIC ACTUATORS:	
4.1.1	STOP VALVE ACTUATORS WITH COMPLETE CONTROL BLOCKS (TYPE: SVA-250-98-352) FOR HP STOP VALVES (HORIZONTALLY MOUNTED VALVE)	2 NOS. (ARRANGEMENTS WILL IN MIRROR IMAGE)
4.1.2	CONTROL VALVE ACTUATORS WITH COMPLETE CONTROL BLOCKS (TYPE: CVA-200-80-347) FOR HP CONTROL VALVES (HORIZONTALLY MOUNTED VALVE)	2 NOS. (ARRANGEMENTS WILL IN MIRROR IMAGE)
4.1.3	STOP VALVE ACTUATORS WITH COMPLETE CONTROL BLOCKS (TYPE: SVA-560-208-92) FOR IP STOP VALVES (VERTICALLY MOUNTED VALVE)	2 NOS. (ARRANGEMENTS WILL IN MIRROR IMAGE)
4.1.4	CONTROL VALVE ACTUATORS WITH COMPLETE CONTROL BLOCKS (TYPE: CVA-500-170-104) FOR IP CONTROL VALVES (HORIZONTALLY MOUNTED VALVE)	2 NOS. (ARRANGEMENTS WILL IN MIRROR IMAGE)
4.1.5	CONTROL VALVE ACTUATOR WITH COMPLETE CONTROL BLOCK (TYPE: CVA-125-50-324) FOR OVERLOAD CONTROL VALVE (HORIZONTALLY SUSPENDED VALVE);	1 No.
4.2	SPECIAL TOOLS AND TACKLES FOR ASSLY & DIS-ASSLY. FOR ACTUATORS	1 SET
4.3	COMMISSIONING SPARES	1 SET
4.4	TRAINING & SUPERVISION DURING ERECTION & COMMISSIONING AT SITE:	REQUIRED FOR EACH SET

Buyer Specific Special Terms and conditions

Item name:Electro Hydraulic Actuator of Turbine Valves , Project: Talchar

Please note that this tender enquiry has been issued through BHEL's e-procurement portal developed by NIC (<https://eprocurebhel.co.in/>), hence PAPER BID or BID THROUGH e-MAIL SHALL NOT BE ENTERTAINED FOR THIS TENDER. Please upload your e-bid in BHEL's e-procurement portal developed by NIC (<https://eprocurebhel.co.in/>).

Sl. No	Terms	Description	Bidder's confirmation
1.	Mandatory Procurement (Make In India)	This is domestic open tender enquiry and only class -1 and class-II local suppliers are eligible to participate in this tender enquiry under compliance of PPP-MII Order No. P-45021/ 2/ 2017-PP (BE-II) dtd. 04/06/2020 of Govt of India. Purchase preference to class-1 local supplier over class2 supplier shall be applicable as per PPP-MII Order No. P45021/ 2/ 2017-PP (BE-II) dtd. 04/06/2020 of Govt of India	
2.	Confirmation to general instructions and standard terms & conditions	Please submit signed and stamped copy of your offer on each page along with following documents; <ul style="list-style-type: none">• General Instructions and standard terms & conditions for bidding against tender enquiry (GISTC enclosed):• Instruction to bidders• Additional T&C.• PQR & its supportive document.• Technical drawing & purchase specification.• Quality plan.• Certificate/self-certification for minimum local content as per PPP-MII order.• Replica of price bid schedule/BOQ without prices with part-I offer. Please note that technical documents shall be shared against submission of NDA (NDA copy enclosed) .	
3.	Customer approval requirement	End User approval is mandatory requirement for considering your offer in this tender. Kindly submit your credentials with filled NTPC questionnaire with all supporting documents along with your offer for take up your approval with End User. Price bid of the offer of only those bidders who will be approved by the End User will be considered for price bid opening.	
4.	Evaluation criteria	Evaluation shall be done project wise on total landed cost upto respective BHEL Project Site considering all material codes and services together. Services Include: Supervision during Erection & Commissioning and Training. Prices shall be quoted strictly as per BOQ only .	
5.	Consignee details	Talchar project consignee details is as follows; NTPC LIMITED, TALCHER TPP, STAGE-III 2X660MW PO TALCHER, DISTT- ANGUL STATE OF ODISHA, PIN 759101	
6.	Bid validity/ Validity of offer	Please note that validity of the offer shall be 180 days from the date opening of Techno-Commercial bid (Part-I bid) on NIC portal. Offer of	

Buyer Specific Special Terms and conditions

Item name:Electro Hydraulic Actuator of Turbine Valves , Project: Talchar

		bidder's having validity less than 180 days shall liable to reject. BHEL reserve the right to reject the offer in case validity of offer less than 180 days. Please confirm.	
7.	Technical Requirement for Talchar Project:	The offer shall be sent complete in all respect along with all the relevant documents as mentioned against clause 9 of bhel drg. no. 1-11400-30510 1-11400-30520, 1-11400-56511, 1-11400-30540 & 1-11400-56512, kindly confirm.	
		In the event of ordering the vendor shall furnish all the documents as per drg. no. 31140056501 (MDL), complying time schedule mentioned therein.	
		The Vendor to provide 3D models for the supplied equipment assemblies (having all the components included) complete with all connection points/interfaces for the purpose of 3D power plant layout to be done by BHEL as per Customer specification requirements. The file formats of 3D models shall be informed by BHEL and the same shall be subject to Customer approval."	
		Kindly offer the make/model of servo valves as per BHEL specification. In case, supplier offer equivalent make/model, the same to be got approved from Siemens Germany else the equivalent offered servo valve should be proven one and should also have minimum 3 years of satisfactory running experience in steam turbine of mw rating 660 or above all the supporting documents along with end user certificate to be furnished by the vendor in support of satisfactory running experience.	
		Pl note that training program at site for 2 days shall be provided by the vendor regarding design/construction features, operation & maintenance of the supplied equipment (including C&I) to customer / BHEL Engineers.	
8.	Basis of quotation:	Kindly Confirm that material prices have been quoted on Ex-Works with freight Pre-paid up to destination basis. The goods can be dispatched through any BHEL approved transporters having their branch at Haridwar. The names and addresses of transporters approved by IBA as well as BHEL are posted at our website www.bhelhwr.co.in . Pls. note that, if you dispatch the material by any BHEL un-approved transporter then you will be required to furnish the MRC (Material Receipt Certificate) from Project Site for processing of your invoice. No demurrage charges would be borne by BHEL.	
		Transit insurance would be arranged by BHEL. Please send your offer keeping this in view.	
9.	Recommended Spares	Please submit item wise price list of each item referred in BHEL Drawing no 2-11400-56510 (Recommended Spare Parts) for Talchar Project .These prices shall be used for our reference and future ordering (if required) and not to be considered for Evaluation.	
10.	SPECIAL INSTRUCTION	Please note that as per BHEL's Policy, we cannot allow Price impact for the requirement / scope of supply, which is a part of specifications of our tender enquiry. Hence please read all specification / documents thoroughly and submit your offer as per specifications of tender enquiry. In case of any confusion / un-clarity on any of the clause / requirement of specification, please clarify the same from BHEL before submission of offer.	

Buyer Specific Special Terms and conditions

Item name:Electro Hydraulic Actuator of Turbine Valves , Project: Talchar

		<p>No deviation & request regarding un-clarity / contradictory conditions / ambiguity of specifications would be entertained after opening of techno-commercial offers. Further no price impact would be allowed for the requirement which is already part of the specifications of the tender enquiry, after opening of techno-commercial offers.</p> <p>Please note and confirm.</p>	
11.	Engineering Document/ Document approval	<p>Please quote your valuable offer as per BHEL documents, drawings, specifications etc. as per the tender enquiry.</p> <p>The document no. " CIE-EHA-G3 (PURCHASE SPECIFICATION FOR CIE FOR ELCTRO HYDRAULIC ACTUATORS FOR MAIN TURBINE VALVES)" is part of BHEL purchase specification and shall be complied by the vendor., kindly confirm.</p> <p>EHA documents submitted by vendor for BHEL'S approval shall also be subject to customer's approval. therefore, timely submission of the complete set of EHA documents must be ensured by the vendor.</p> <p>Spec ST22009, wherever called in the BHEL specification drawing to be read as ST22007.</p> <p>Drawings/Data sheets/documents & Quality plan as called for in the specifications/Drawings/Documents shall be submitted for approval to BHEL for BHEL/customer approval within 30 days of purchase order. Any delay in delivery on account of late submission of drawings shall be to vendors account. BHEL will arrange the approval of the drawings/data sheets/ documents within 30 days of their receipt provided those are complete in all respect. Any delay in documents submission/approval shall be on either side.</p> <p>Documents required after order placement: Kindly note & confirm that in the event of ordering, you will furnish all the documents as per Annexure-1 (MDL), complying time schedule mentioned therein. for BHEL review and approval.</p>	
12.	Supervision during Erection & Commissioning and Training	<ul style="list-style-type: none"> Kindly note that the vendor shall carry out supervision work during Erection & Commissioning of the equipment. Since there are substantial interfaces of EHA with HPSU, therefore vendor shall carry out their supervision work at site to ensure satisfactory commissioning of all EHA's along with associated HPSU. Kindly quote the lumpsum price of the same in your offer. A period of total 12 man-days has been envisaged for supervision during erection & commissioning for 2 units of Talchar set & 02 mandays for training (once for project). Kindly note that training program at site for 2 (Two) days (Once for Total Project) shall be provided by the vendor regarding design/ construction features, operation & maintenance of the supplied equipment's (Including C&I) to customer/ BHEL Engineers. <p>Please ensure that "Per Man Day" & "Per Visit" charges for Supervision during Erection & Commissioning and Training including every expense are quoted. For evaluation total 14 Mondays and 3 visit charges shall be considered for commissioning and training.</p>	

Buyer Specific Special Terms and conditions

Item name:Electro Hydraulic Actuator of Turbine Valves , Project: Talchar

		<p>Please note that the charges quoted for Supervision during Erection & Commissioning and Training shall be inclusive of applicable GST & TDS.</p>	
		<p>Please note that BHEL will deduct tax (TDS) from your bill of supervision (if Included by bidders) as per rules and regulations of Government of India, at the time of payment of supervision and furnish Tax Deduction at Source (TDS) Certificate. If TDS is not included in the prices, loading of the same will be done for evaluation.</p>	
		<p>Please note that the vendor should send a checklist to BHEL prior to deputation of competent representative for Commissioning. BHEL will confirm the checklist prior to issuing Commissioning Call to the vendor. After receipt of checklist from BHEL, the vendor would send the competent representative within 15 days of confirmation of site readiness. <u>In case, any additional work is required which is beyond the scope/warranty/guarantee of the vendor, the work would be commenced only after signed agreements with site representative & the vendor.</u></p>	
13.	Liquidated Damages	<p>Liquidated Damages for late delivery w.r.t to contractual delivery shall be applicable @ 0.5% of the “lot-wise total order value” per week of delay or part thereof subject to a maximum of 10% of the “lot-wise total order value”.</p> <p>Date of LR shall be considered as actual date of delivery. Please confirm your acceptance.</p>	
		<p>Please note that in case of any deviation in the penalty terms, loading will be done to the extent the late delivery penalty is not accepted by the vendor.</p>	
14.	Risk Purchase:	<p>In case of abnormal delays (beyond the maximum late delivery period as per LD clause) in supplies / defective supplies or non-fulfillment of any other terms and conditions given in Purchase Order, BHEL may cancel the Purchase Order in full or part thereof, and may also make the purchase of such material from elsewhere / alternative source at the risk and cost of the supplier. BHEL will take all reasonable steps to get the material from alternate source at optimum cost. If bidder does not agree to the above Risk Purchase Clause, BHEL reserves the right to reject the offer. In case for compelling reasons BHEL accepts the offer without acceptance of this clause by the bidder and in the eventuality of Risk Purchase, appropriate action will be taken as per BHEL extant rules. This will be without prejudice to any other right of BHEL under the contract or under General Law.</p>	
15.	Action against Bidders / vendor / supplier / contractor in case of default	<p>In order to protect the commercial interests of BHEL, BHEL shall take action against supplies / contractors by way of suspension of business dealings, who either fail to perform or are in default without any reasonable cause, cause loss of business/ money/ reputation, indulge in malpractices, cheating, bribery, fraud or any other misconduct or formation of cartels so as to influence the bidding process or influence the price etc.</p> <p>Suspension of Business Dealings could be in the form of “Hold” or “Banning” a supplier/ contractor or a bidder and shall be as per “Guidelines for Suspension of Business Dealings with Suppliers/ Contractors” available at BHEL’s website</p>	

Buyer Specific Special Terms and conditions

Item name:Electro Hydraulic Actuator of Turbine Valves , Project: Talchar

		"https://www.bhel.com/guidelines-suspension-business-dealings-supplierscontractors"	
16.	Requirement of a bidder which shares a land border with India.	In case a bidder is proposed to supply finished goods directly/indirectly from supplier from the countries sharing land border with India, such supplier has to be registered with the Competent Authority.	
17.	Payment Terms	Payment for Material Portion: 100% Payment after receipt of material/items at BHEL project sites with PBG for 5% of the order value which is as per provisions inline with clause 10 of GISTC.	
		Supervision during Erection, Commissioning and training: 100% Payment against submission of successful Erection/ commissioning/ training certificate (as applicable) from Project Site and invoice thru Bank / direct to BHEL. Payment will be made on actual number of days and visits involved in supervision of commissioning as certified by the project site.	
		Please note that in case of any deviation in the payment terms, BHEL shall evaluate your offer after loading on account of deviation in payment terms as per BHEL practice / policy. Requirement of PBG for Guarantee/ Warranty period is mandatory and non-acceptance of the PBG may lead to rejection of your offer.	
18.	Performance Bank Guarantee	<p>PBG (performance bank guarantee) shall be submitted for 5% of the order value (lotwise). PBG should be valid for entire Guarantee/ Warranty period. PBG shall be submitted for processing of invoices.</p> <p>This should be read and complied in conjunction with Bank Guarantee clause in General Instructions and Standard Term and Conditions for bidding against Tender Enquiry (herein called as GISTC).</p> <p>Item wise/Lot wise PBG will be acceptable in line with shipment of items</p>	
19.	Conflict of interest	<p>A bidder shall not have conflict of interest with other bidders. Such conflict of interest can lead to anti-competitive practices to the detriment of Procuring Entity's interests. The bidder found to have a conflict of interest shall be disqualified. A bidder may be considered to have a conflict of interest with one or more parties in this bidding process, if:</p> <p>they have controlling partner(s) in common; or</p> <p>they receive or have received any direct or indirect subsidy/ financial stake from any of them; or</p> <p>they have the same legal representative/agent for purposes of this bid; or</p> <p>they have relationship with each other, directly or through common third parties, that puts them in a position to have access to</p>	

Buyer Specific Special Terms and conditions

Item name:Electro Hydraulic Actuator of Turbine Valves , Project: Talchar

		<p>information about or influence on the bid of another Bidder, or</p> <p>Bidder participates in more than one bid in this bidding process. Participation by a Bidder in more than one Bid will result in the disqualification of all bids in which the parties are involved. However, this does not limit the inclusion of the components/ sub-assembly/ Assemblies from one bidding manufacturer in more than one bid; or</p> <p>In cases of agents quoting in offshore procurements, on behalf of their principal manufacturers, one agent cannot represent two manufacturers or quote on their behalf in a particular tender enquiry. One manufacturer can also authorize only one agent/dealer. There can be only one bid from the following:</p> <p>The principal manufacturer directly or through one Indian agent on his behalf; and</p> <p>Indian/foreign agent on behalf of only one principal, or</p> <p>A Bidder or any of its affiliates participated as a consultant in the preparation of the design or technical specifications of the contract that is the subject of the Bid, or</p> <p>In case of a holding company having more than one independently manufacturing units, or more than one unit having common business ownership/management, only one unit should quote. Similar restrictions would apply to closely related sister companies. Bidders must proactively declare such sister/ common business/ management units in same/similar line of business.</p>	
20.	Arbitration, Risk Purchase & FORCE MAJEURE	Kindly confirm Arbitration, Risk Purchase & Force Majeure shall be applicable as per GISTC, as applicable (copy enclosed).Please confirm all three clauses as per GISTC.	
21.	Quality Requirement	<ul style="list-style-type: none"> • Kindly submit the quality plan in enclosed format for BHEL approval. • After placement of PO, successful supplier to submit revised quality plan after incorporating NTPC comments, to be submitted to NTPC for approval. Kindly specifically confirm to follow customer approved QP. • Kindly confirm that Inspection shall be done by Third Party Inspection agency M/s TUV & NTPC as per NTPC approved quality plan. • For spare items, Kindly submit test certificates endorsed by third party inspection agency as per customer approved QP. <p>Inspection charges will be borne by BHEL. All coordination with third party inspection agency shall be done by the supplier only. Inspection call to third party inspection agency may be raised directly by the supplier; however 15 days are to be provided for deputation of representative of third party inspection agency for inspection.</p>	

Buyer Specific Special Terms and conditions

Item name:Electro Hydraulic Actuator of Turbine Valves , Project: Talchar

22.	MDCC Clause	<p>Please confirm that material shall be dispatched only after issue of MDCC from BHEL.</p> <p>The Test Certificates/Inspection reports/COC/Interchangeability Certificate as per approved quality plan shall be submitted to BHEL for review and acceptance before dispatch of Material. The Material Dispatch Clearance (MDCC) will be provided by BHEL within 07 days of receipt of documents, provided those are complete in all respects. Material shall be dispatched within one week of issue of MDCC (material dispatch clearance certificate) by BHEL.</p>	
23.	Guarantee/Warranty	<p>Kindly confirm the following Guarantee/Warranty clause;</p> <ul style="list-style-type: none"> • Standard Guarantee/Warranty period shall be provided for a period of 36 months from the date of supply or 18 months from commissioning, whichever is earlier. In case of any failure or trouble reported from site, the supplier should depute their representative immediately to attend the problem and replace the defective component/part if required, without any additional cost to BHEL. • The supplier to provide technical support/services or alternative solutions against any issues; reported in the equipment supplied by the vendor for up to at least 10 years from the supply date. • Minimum acceptable criteria of Guarantee/Warranty shall be 30 months from the date of supply or 12 months from the date of commissioning. Loading@2% per annum of the order value will be done for reduced period on the suppliers not accepting standard Guarantee/Warranty period. 	
24.	O&M Manuals	<p>Kindly confirm that in the event of ordering O&M manuals will be provided in 21 nos. of Hard Copies and 06 CD ROMs as per clause 2.4.1 of BHEL drawing no. 1-11400-56012 for each project. Out of these, 18 Nos. Hard Copies & 5 CD ROMs of O&M Manuals would be supplied directly to BHEL Haridwar and balance O&M Manuals shall be supplied along with the equipment at site and description of the same should be mentioned in packing list.</p> <p>Kindly note that your documents including O&M Manual shall bear the details as per cover page (Annexure-IV). Further the cover page of the O&M Manual shall be bilingual in Hindi & English Language.</p>	
25.	Packing and Storage	<p>Kindly confirm the following packing requirements;</p> <ul style="list-style-type: none"> • All the equipments/items shall be supplied in closed steel boxes/closed wooden boxes with steel cover sheet. packing boxes should be rain proof. Kindly confirm. • Packaging of item should be done in such a way that it should not require any internal package inspection for at least one year. • Packing box of mandatory spares shall be painted with green color for easy identification at project sites. • All the equipments /items shall be dispatched in seaworthy packing as per packing instruction document no. HW0232898. • STORAGE & HANDLING INSTRUCTIONS OF THE EQUIPMENTS SHALL BE FURNISHED BY THE VENDOR SEPARATELY AND 2 	

Buyer Specific Special Terms and conditions

Item name:Electro Hydraulic Actuator of Turbine Valves , Project: Talchar

		COPIES OF THE SAME SHALL BE SUPPLIED TO SITE ALONG WITH MAIN EQUIPMENTS.													
26.	Special Instructions:-	<p>For Talchar Projects: -</p> <ol style="list-style-type: none"> 1. Before shipment of material, vendor has to obtain QR code from BHEL and these QR codes (properly laminated) shall be affixed on package/boxes/crates/bundles of material to be supplied. while packing the material following is to be ensured. 2. Material of Unit-1, Unit-2 and Mandatory Spares need to be packed in separate boxes. 3. Loos items (if any) need to be packed in boxes/crates or bundled together. For loose items one marker board needs to be send for each bundle for affixing RFID tag at Site. 4. QR code will be issued "Box wise/ bundle wise" vendor to ensure correct QR box are affixed on the boxes/bundles. 													
27.	Mandatory Procurement (Make In India)	This is domestic open tender enquiry and only class -1 and class-II local suppliers are eligible to participate in this tender enquiry under compliance of PPP-MII Order No. P-45021/ 2/ 2017-PP (BE-II) dtd. 04/06/2020 of Govt of India. Purchase preference to class-1 local supplier over class2 supplier shall be applicable as per PPP-MII Order No. P45021/ 2/ 2017-PP (BE-II) dtd. 04/06/2020 of Govt of India													
28.	Order Acceptance :	Ink signed order acceptance shall be furnished within 15 days of order placement. In case, order acceptance do not received within 15 days of order placement, PO deemed to be accepted by you.													
29.	Beneficiary of PO	Kindly confirm on whom the PO will be placed in the event of ordering.													
30.	Delivery	<p>Bidders are requested to offer best possible delivery (project/Lotwise) from PO placement.</p> <p>Early delivery wrt enquiry deliveries shall not be accepted. In such cases PO will be placed with enquiry delivery. Please confirm.</p> <p>Bidders are requested to offer your best possible delivery (project/Lot wise) for following projects in number of weeks/ months applicable from PO placement or approval of drawing & QP whichever is later.</p> <p>Lot1-----Weeks/Months</p>													
31.	Integrity Pact	<p>(a) IP is a tool to ensure that activities and transactions between the Company and its Bidders/ Contractors are handled in a fair, transparent and corruption free manner. Following Independent External Monitors (IEMs) on the present panel have been appointed by BHEL with the approval of CVC to oversee implementation of IP in BHEL.</p> <table border="1"> <thead> <tr> <th>Sl.</th> <th>IEM</th> <th>Email</th> </tr> </thead> <tbody> <tr> <td>1.</td> <td>Shri Otem Dai, IAS (Retd.)</td> <td>iem1@bhel.in</td> </tr> <tr> <td>2.</td> <td>Shri Bishwamitra Pandey, IRAS (Retd.)</td> <td>iem2@bhel.in</td> </tr> <tr> <td>3.</td> <td>Shri Mukesh Mittal, IRS (Retd.)</td> <td>iem3@bhel.in</td> </tr> </tbody> </table> <p>(b) The IP as enclosed with the tender is to be submitted (duly signed by authorized signatory) along with techno-commercial bid (Part-I, in</p>	Sl.	IEM	Email	1.	Shri Otem Dai, IAS (Retd.)	iem1@bhel.in	2.	Shri Bishwamitra Pandey, IRAS (Retd.)	iem2@bhel.in	3.	Shri Mukesh Mittal, IRS (Retd.)	iem3@bhel.in	
Sl.	IEM	Email													
1.	Shri Otem Dai, IAS (Retd.)	iem1@bhel.in													
2.	Shri Bishwamitra Pandey, IRAS (Retd.)	iem2@bhel.in													
3.	Shri Mukesh Mittal, IRS (Retd.)	iem3@bhel.in													

Buyer Specific Special Terms and conditions

Item name:Electro Hydraulic Actuator of Turbine Valves , Project: Talchar

		<p>case of two/ three part bid). Only those bidders who have entered into such an IP with BHEL would be competent to participate in the bidding. In other words, entering into this Pact would be a preliminary qualification.</p> <p>(c) Please refer Section-8 of IP for Role and Responsibilities of IEMs. In case of any complaint arising out of the tendering process, the matter may be referred to any of the above IEM(s). All correspondence with the IEMs shall be done through email only.</p>	
32.	Technical Requirements	Please confirm technical requirement of product as per BHEL drawing , purchase specifications & PQR enclosed.	
33.	Reverse Auction (E-bidding)	<p>BHEL reserves the right to go for Reverse Auction (RA) instead of opening the sealed envelope price bid, submitted by the bidder. This will be decided after techno-commercial evaluation. Kindly give your acceptance for participation in RA.</p> <p>BHEL shall be resorting to Reverse Auction (RA) (Guidelines as available on www.bhel.com) for this tender. RA shall be conducted among the techno-commercially qualified bidders.</p> <p>Price bids of all techno-commercially qualified bidders shall be opened and same shall be considered for RA. In case any bidder(s) do(es) not participate in online Reverse Auction, their sealed envelope price bid along with applicable loading, if any, shall be considered for ranking.”</p>	
34.	General Packing & Shipping instructions	<p>Please confirm the following instructions-</p> <ol style="list-style-type: none"> 1.Guarantee Certificate required to submit. 2.Test Certificate required to submit. 3.O&M manual required 4. Packing & marking shall be done in line of instructions to be issued at the time of dispatch. 5.Vendor to submit packing list (box dimensions, net weight, gross weight etc) & images of boxes before dispatch. 	
35.	Additional Conditions for Assessment	<p>BHEL reserves the right to consider / Not-consider the offers based on the evaluation of documents submitted for the Pre-Qualification Criteria (PQR).</p> <p>BHEL also reserves the right to have on-site assessment of the facilities at supplier’s works during the bid evaluation.</p>	

List of Consortium Bank

Nationalised Bank		Nationalised Bank	
1	Allahabad bank	19	Vijaya Bank
2	Andhra bank		Public Sector Banks
3	Bank of Baroda	20	IDBI
4	Canara Bank		Foreign bank
5	Corporation bank	21	CITI Bank N.A
6	Central bank	22	Deutsche Bank AG
7	Indian Bank	23	The Hongkong and Shanghai Banking Corporation Limited
8	Indian Oversea Bank	24	Standard Chartered Bank
9	Oriental bank of Commerce	25	The Royal Bank of Scotland N.V.
10	Punjab National Bank	26	J P Morgan
11	Punjab & Sindh Bank		Private bank
12	State Bank of India	27	Axis Bank
13	State Bank of Hyderabad	28	The Federal Bank Limited
14	Syndicate Bank	29	HDFC
15	State Bank of Travancore	30	Kotak Mahindra Bank
16	UCO Bank	31	ICICI
17	Union Bank of India	32	Indusind Bank
18	United Bank of India	33	Yes Bank

Certificate by Chartered Accountant on letter head

This is to Certify that M/s
(hereinafter referred to as 'company') having its registered office at is
registered under MSMED Act 2006, (Entrepreneur Memorandum No (Part- II)
....., dtd:.....
Category:.....(Micro/Small). (copy enclosed).

Further verified form the Books of Accounts that the investment of the company as
on date as per MSMED Act 2006 is as follows:

1. **For Manufacturing Enterprises:** Investment in plant and machinery (i.e. original cost excluding land and building and the items specified by the Ministry of Small Scale Industries vide its notification No. S.O.1722(E) dated October 5, 2006:
Rs.....Lacs
2. **For Service Enterprises:** Investment in equipment (original cost excluding land and building and furniture, fittings and other items not directly related to the service rendered or as may be notified under the MSMED act, 2006:
Rs.....Lacs

(Strike off whichever is not applicable)

The above investment of Rs Lacs is within permissible limit of Rs..... Lacs for
.....micro / small (Strike off which is not applicable) Category under MSMED Act 2006.

Or

The company has been graduated from its original category (Micro / Small) **(Strike off whichever is not applicable)** and the date of graduation of such enterprises from its original category is
(dd/mm/yyyy) which is within the period of 3 years from the date of graduation of such enterprises from its original category as notified vide S.O. No. 3322(E) dated 01.11.2013 published in the gazette notification dated 04.11.2013 by Ministry of MSME.

Date:

(Signature)
Name-
Membership Number-
Seal of Chartered Accountant



BHARAT HEAVY ELECTRICALS LIMITED

HEEP-HARIDWAR, UTTARAKHAND (249403)

General Instructions and Standard Terms & Conditions for bidding against Tender Enquiry (GISTC)

For Indian Bidders (Version June-2021, Rev: 06)

Table of Contents

1. GENERAL	1
2. ORIGIN OF QUOTATION	1
3. SUBMISSION OF TENDER	1
4. TENDER OPENING	2
5. SPECIFICATION, DRAWINGS & STANDARD	2
6. PRICE SCHEDULE	3
7. REVERSE AUCTION	3
8. DELIVERY TERMS	3
9. LD FOR LATE DELIVERY	4
10. PAYMENT TERMS	4
11. TAXES & DUTIES	5
12. BANK GUARANTEE	6
13. GUARANTEE / WARRANTY AND CORRESPONDING REPAIRS / REPLACEMENT OF GOODS	6
14. QUALITY REQUIREMENT	6
15. VALIDITY	6
16. RIGHT OF ACCEPTANCE	6
17. TRANSIT INSURANCE	7
18. RISK PURCHASE	7
19. FORCE MAJEURE CLAUSE	7
20. NON-DISCLOSURE AGREEMENT	8
21. SETTLEMENT OF DISPUTES / ARBITRATION	8
22. WHARFAGE / DEMURRAGE RESPONSIBILITY	8
23. CONDITIONS FOR AVAILING MICRO & SMALL ENTERPRISES (MSE'S) BENEFITS	8
24. INFORMATION TO THE BIDDERS	10
25. MAKE IN INDIA (GOVT-NOTIFICATION)	10
26. RESTRICTIONS UNDER RULE 144(XI) OF THE GENERAL FINANCIAL RULES (GFRs), 2017	12

27. NOTE..... 12

1. GENERAL.

These general terms & conditions shall apply to all the Tender Enquiries, notice inviting tenders, request for quotations concerning the supply of goods and / or rendering of services to Bharat Heavy Electricals Ltd., HEEP, Haridwar (hereinafter referred to as BHEL or the Purchaser). In case of placement of order these conditions will become part of Purchase Order (P.O) until unless the deviations are specifically agreed by BHEL.

2. ORIGIN OF QUOTATION.

- a) The quotation should preferably be from the principal bidder. However tender specific authorized registered dealer/agent can also submit the bid on their behalf, failing which the quotation is liable to be ignored. BHEL prefers to deal directly with the principal manufacturers.
- b) An agent cannot quote on behalf of more than one principal in the same Tender Enquiry.

3. SUBMISSION OF TENDER.

- a) Bid / Quotation must be enclosed in sealed cover on which tender enquiry number and the due date MUST BE written and be invariably sent under REGISTERED POST / SPEED POST / COURIER / Dropped in the Tender Box: addressed as follows:

Quotation against Enquiry No. _____

Dated: _____

Due on: _____

To,

**THE HEAD OF MATERIALS MANAGEMENT,
Heavy Electrical Equipment Plant,
Bharat Heavy Electricals Limited,
HARIDWAR-249403 (Uttarakhand), INDIA.**

- b) TENDER ROOM is located at: Room No. - 415, 4th Floor, Main Admin. Building, BHEL-HEEP, Haridwar.

Quotations / Bids not in accordance with General Instructions and Standard Terms & Conditions are likely to be ignored.



BHARAT HEAVY ELECTRICALS LIMITED

HEEP-HARIDWAR, UTTARAKHAND (249403)

General Instructions and Standard Terms & Conditions for bidding against Tender Enquiry (GISTC)

For Indian Bidders (Version June-2021, Rev: 06)

- c) In case of Three / Two Part Bid, technical bid containing technical offer, duly signed and un-priced copy of the Price Bid should be kept in one envelope. Price Bid containing only the price should be kept in a separate envelope. All envelopes indicating Part-1 or Part-2 or Part-3 as the case may be to be put in a bigger envelope. Please note that un-priced bid should be the exact replica of price bid but without prices.
- d) The bid / quotation must be posted before due date, keeping allowance for postal transit time. Quotations sent by any mode but not received in time will be ignored. Tender received through authorized E-mail is also acceptable. However, in time submission of tender in tender box shall be the responsibility of the bidder, sent through any mode. Documents submitted with the offer / bid shall be signed and stamped in each page by authorized representative of the bidder.
- e) Any additional documents submitted by supplier / bidder, during processing of registration application / tender or after placement of order shall not be accepted unless it is submitted with forwarding letter and duly signed and stamped.
- f) The bids of the bidders who are on the banned list and also the bids of the bidders, who engage the services of the banned firms, shall be rejected. The cutting / overwriting in the bid / offer must be duly attested by the signatories to the bid. The list of firms banned by BHEL is available on BHEL web site www.bhel.com.
- g) Being PMD vendor, if you are not quoting against this tender enquiry, please send your regret letter positively for our reference with valid reasons for not participating in the tender enquiry. Repeated lack of response on the part of bidder may lead to deletion such PMD vendor from BHEL's approved vendor list.
- h) The bidders will submit Integrity Pact, duly signed by its authorized signatory, along with their bids wherever estimated tender value is Rs. 2 Crore or more.
- i) In case of open tender, technically qualified unregistered bidders may apply online for registration through <http://www.bhel.com/index.php/vender>.
- j) BHEL reserves the right to award tendered quantities among more than one bidder (after acceptance of L1 price by the other bidders). BHEL can also consider awarding of part of the tendered quantity to other than L-1 bidder at L1 counter offered rates, if the quantity offered by the L-1 bidder is less than the quantity tendered for.
- k) In case of e-Tendering (Online bidding through e-portal), offline bid submitted in hard copy or in any other form by the vendor / supplier will not be accepted and will be rejected out rightly. Only e-portal bid will be accepted.

4. TENDER OPENING.

Tender opening is scheduled to start in the Tender Room at 2:00 PM, on the due date. Therefore, bid / quotations must reach this office / tender Box latest by 1:45 PM on due date. Only participating bidders are allowed to attend tender opening. **TENDERS RECEIVED AFTER THE SPECIFIED TIME OF THEIR 'SUBMISSION' WILL BE TREATED AS LATE TENDERS AND SHALL NOT BE CONSIDERED UNDER ANY CIRCUMSTANCES.** The bidders or their authorized representatives may be allowed to attend tender opening if duly authorized by their principals, through a tender specific letter on that particular day. General authorization letter is not acceptable.

Note: - Foreign bidders willing to attend the bid opening has to provide the requisite documents to the concerned Purchase executives for arranging gate pass for them.

5. SPECIFICATION, DRAWINGS & STANDARD.

- a) Bidders must give their detailed specification in the quotation along with relevant technical literature / catalogue etc. against the tender enquiry.
- b) The Bid should be accompanied with relevant copies of catalogues, drawings or specification as per tender enquiry.

Quotations / Bids not in accordance with General Instructions and Standard Terms & Conditions are likely to be ignored.



BHARAT HEAVY ELECTRICALS LIMITED

HEEP-HARIDWAR, UTTARAKHAND (249403)

General Instructions and Standard Terms & Conditions for bidding against Tender Enquiry (GISTC)

For Indian Bidders (Version June-2021, Rev: 06)

If these documents are not furnished, the offer is liable to be rejected.

- c) Wherever national / international (N/IN) standards are referred, the latest N/IN standards are to be followed. Mention year & date of standard revision that shall be followed for the supply.
- d) All Drawings and Standards are proprietary of BHEL. It must not be used in anyway detrimental to the interest of BHEL or without permission of BHEL.

6. PRICE SCHEDULE.

- a) Kindly quote your prices in figures and words both. In case of any discrepancy in value, the prices quoted in words shall be considered for evaluation and establishing L1 status.
- b) Prices quoted should not be more than the prices quoted to any other BHEL units / offices / divisions. Vendor to submit copy of latest Purchase Order placed by any unit of BHEL for similar items in the technical bid. In case no order has been placed on such items, specific confirmation that no order has been placed on such items should be provided.
- c) Prices should be quoted on F.O.R. Destination basis. Transit insurance shall be arranged by BHEL and not to be included in the prices. The offers quoted on other than F.O.R destination basis may result in non-consideration of such bids.
- d) In case BHEL accepts the EX-Works prices, such offers will be loaded by 1.5% of EX-Works value towards freight or with actual freight charges as per BHEL freight rate contract whichever is higher.
- e) In case of Indigenous items covered by DGS & D Rate Contract, the bidders should submit latest valid copy of the rate contract along with bid / quotation
- f) Applicable **IGST / CGST / SGST** and any other statutory levy should be indicated separately and clearly in the bid / quotation.

- g) Bidders can dispatch goods through any Indian Bank Association approved transporters having their branch at HARIDWAR / destination. If material is dispatched through other than Indian Bank Association approved transporter, material to be delivered on door delivery BHEL Stores basis.
- h) In case of dispatch of material through any other unapproved transporter, payment shall be made only after receipt of material and any additional charges payable to the transporter shall be to the bidder's account.
- i) Any demurrage / godown rent payable to the transporter / or to godown's owner due to any delay attributed by the supplier shall be recovered from supplier's account.
- j) Currency of Evaluation shall be INR.

NB: Financial evaluation of L1, L2Status will be on the basis of Landed Cost to BHEL.

7. REVERSE AUCTION.

Wherever RA is declared in the special terms and conditions of tender enquiry, following shall be applicable and Bidders to confirm the same:

"BHEL shall be resorting to Reverse Auction (RA) (Guidelines as available on www.bhel.com) for this tender. RA shall be conducted among all the techno-commercially qualified bidders.

Price bids of all techno-commercially qualified bidders shall be opened and same shall be considered as initial bids of bidders in RA. In case any bidder(s) do(es) not participate in online Reverse Auction, their sealed envelope price bid along with applicable loading, if any, shall be considered for ranking."

8. DELIVERY TERMS.

- a) Goods shall be delivered on 'FOR Destination' basis to the named destination unless otherwise called for in the tender enquiry.
- b) Loading on account of 3rd party inspection charges in case of Indian bidders shall be 0.20%.

Quotations / Bids not in accordance with General Instructions and Standard Terms & Conditions are likely to be ignored.



BHARAT HEAVY ELECTRICALS LIMITED

HEEP-HARIDWAR, UTTARAKHAND (249403)

General Instructions and Standard Terms & Conditions for bidding against Tender Enquiry (GISTC)

For Indian Bidders (Version June-2021, Rev: 06)

9. LIQUIDATED DAMAGES (LD) FOR LATE DELIVERY.

a) Where items of Purchase Order are independently usable.

Liquidated Damages (LD) for Late Deliveries shall be applicable @0.5% per week or part thereof on the value of respective delayed supplies subject to a maximum of 10% of the value of respective delayed supplies. Value of delayed supplies will mean the Gross Value payable to the vendor (Before LD) against such supplies excluding taxes and duties.

b) Where the total items are required for a main equipment and items are interdependent.

Liquidated Damages (LD) for Late Deliveries shall be applicable @0.5% per week or part thereof on total value of Purchase Order subject to maximum of 10% of the total value of Purchase Order. Purchase Order value for this purpose shall be the Total Gross Value payable to the vendor (Before LD) excluding taxes and duties.

c) Bidders are requested to quote the best delivery meeting the delivery requirements. BHEL reserves the right to reject the offers not meeting BHEL's delivery requirement.

d) Commencement of delivery period shall be reckoned from the date of PO / LOI or any other agreed milestone.

e) Bidder shall deliver the goods in the manner and schedule agreed under the terms and conditions of Purchase order.

f) DELIVERY IN CASE OF REJECTION: In case the material is rejected, then date of replacement will be considered as the actual date of delivery.

g) DELIVERY AGAINST BANK DOCUMENTS: In case payment terms quoted by bidder are documents through bank, and the delivery terms being "FOR Haridwar / FOR Transporter Go-down" then date of delivery will be date of intimation by transporter / bidder of delivery of material at Haridwar for the LD purpose.

h) Where the payments are through bank, the documents may be presented for negotiation to BHEL authorized / nominated bank.

i) Payment of Liquidated Damages (LD) shall not in any way relieve the vendor from any of its obligations & liabilities under the contract.

10. PAYMENT TERMS.

a) BHEL's standard payment term is Payment after receipt and acceptance of materials / items at HEEP, BHEL-Store or at desired destination unless otherwise specified in Special Terms attached to the tender enquiry.

b) BHEL reserves the right to accept or reject the offer of the bidder who quotes the payment term other than BHEL's standard payment term.

c) Loading on account of deviation in payment terms shall be done as per extant rules of BHEL-Haridwar.

d) 100% payment along with taxes, freight & insurance will be made after receipt and acceptance of material and within 75 days from the date of invoice subject to submission of non-discrepant documents within 15 days of supply as per terms and conditions of Purchase Order. In case any discrepancy found in the documents, BHEL will notify the same to vendor within 7 days of receipt. Vendor has to clear all the discrepancies in one go within 7 days thereafter else the payment of vendor may get delayed.

e) For MSEs (covered under MSME Act) which are registered and periodically renewed with BHEL, the payment will be made within 45 days or as prescribed in the relevant act.

f) Adherence to the above time schedule of payment is contingent upon Vendor complying with GST Rules w.r.t availment of Input Tax Credit by BHEL.

g) In case GST credit is delayed / denied to BHEL, due to non / delayed receipt of goods and / or tax invoice or expiry of the timeline prescribed in GST Law for availing such ITC, or any other reason not attributable to BHEL, GST amount shall be recoverable from Vendor along with interest levied / leviable on BHEL.

h) The taxes and duties that are reimbursed would be the ones applicable as on the contractual Purchase order delivery date or the amount actually paid whichever is less.

Quotations / Bids not in accordance with General Instructions and Standard Terms & Conditions are likely to be ignored.



BHARAT HEAVY ELECTRICALS LIMITED

HEEP-HARIDWAR, UTTARAKHAND (249403)

General Instructions and Standard Terms & Conditions for bidding against Tender Enquiry (GISTC)

For Indian Bidders (Version June-2021, Rev: 06)

i) **The loading criteria for the different payment terms shall be as under;**

Payment Terms	Days of Loading
After Receipt & Acceptance of material within 75 days of supply.	No Loading
Against Delivery at BHEL-Stores Haridwar.	45
Against documents through bank (CAD):	45
Letter of Credit (LC)	120
Usance LC	No Loading if usance period is > 120 Days.
	Loading of days' difference i.e. difference between 120 days and usance period if the usance period is < 75 days.
Advance	Delivery Period + 120 Days - Advance Payment Days.

11. TAXES & DUTIES.

- a) The bidder to specify in their offer (part 1 bid) the category of their registration under GST like Registered, Unregistered and composite dealer.
- b) The provisional GST registration number of Bharat Heavy Electrical Ltd, Heavy Electricals Equipment Plant, Ranipur, Haridwar is "05AAACB4146P1ZL" with state Code as "05" and State Name as "Uttarakhand".
- c) Please quote our provisional GST registration number in all invoices raised for supply of goods and services under GST regime and also ensure filing of timely return and payment of tax and compliance of other applicable provisions on supplier under GST regime.
- d) No GST will be reimbursed to unregistered or composite dealer. In the event, any GST is quoted by composite dealer, the same shall be added to the cost of supply in evaluating the bid.
- e) Since, input credit of GST will be available to BHEL-Haridwar only after correct filing of return and payment of applicable GST by supplier, reimbursement of GST shall be made by

BHEL-Haridwar on matching of vendor inputs at GST portal, ensuring availability of input credit to BHEL Haridwar. Payment of GST will be made to vendor after matching of input credit and vendor to ensure submission of their invoices along with consent to accept payment of tax after such matching in all cases where bills are submitted directly to BHEL-Haridwar or through bank or under LC or through any other mode.

- f) In the event of any disallowance of input credit or applicability of interest or any other financial liability arises on BHEL-Haridwar due to any default of supplier under GST, such implication shall be to supplier's account.
- g) In the event of any change in the status of the vendor after the submission of the bid but before the supply, GST applicable at the time of supply or in the bid, based on the registration status of the vendor, whichever is lower shall be payable.
- h) Where ever applicable If PAN (Permanent Account Number) of the recipient is not available, income tax is deductible either at the normal rate or at the rate of 20 percent, whichever is higher as per Section 206AA of Indian Income Tax Act 1961.
- i) The bidder shall clearly indicate HSN (*Harmonised System Nomenclature*) / SAC (*Service Accounting Code*), its description and applicable rate of GST for each item in his techno-commercial bid.
- j) Statutory Variation in Taxes & duties as applicable at the time of supply shall be payable. However, in the event of no change in law but bidder quoting certain tax structure in bid document which is lower than the applicable one, such amount shall be the maximum amount of tax that can be claimed by bidder.
- k) **IMPORTED GOODS OFFERED BY INDIAN BIDDERS AGAINST DEALER INVOICE:** Wherever the material being offered is imported, the bidder must quote the prices inclusive of IGST. The rate and value of IGST as included in the price must be indicated separately. In case quantum of IGST is not mentioned by the bidder the same will not be considered for



BHARAT HEAVY ELECTRICALS LIMITED

HEEP-HARIDWAR, UTTARAKHAND (249403)

General Instructions and Standard Terms & Conditions for bidding against Tender Enquiry (GISTC)

For Indian Bidders (Version June-2021, Rev: 06)

evaluation. However, bidder will have to pass on the benefit of IGST to BHEL at the time supply.

- l) In case of directly dispatchable items to Customer's Site, BHEL-Haridwar will inform the GST registration number of the respective customer which must be mentioned on the vendor's invoice. Vendor to ensure availability of such information from BHEL-Haridwar before dispatch of any material. However, while filing GSTN-1, BHEL Haridwar GSTN number to be quoted.

Note: - Vendors must ensure compliance of all the applicable rules and procedure as envisaged in the GST Regime. Any loss to BHEL-Haridwar due to fault / non-compliance by the vendor will be to the vendor's account.

12. BANK GUARANTEE.

In case the bank guarantees are required to be deposited towards security deposit/performance guarantee or for any other purpose as per the terms of this tender enquiry, such bank guarantees of the requisite value in the denominated currency of the purchase order should be from one of the Indian branch of BHEL consortium banks and the bank guarantee should be in the proforma as prescribed by BHEL. The proforma of bank guarantee and the list of consortium banks are displayed at BHEL website www.bhelhwr.co.in. However, in case the bank guarantee is not from BHEL consortium banks, then the bidder has to get the bank guarantee confirmed from one of the Indian branch of BHEL consortium banks and the bank charges for such confirmation will be borne by the bidder.

13. GUARANTEE / WARRANTY AND CORRESPONDING REPAIRS / REPLACEMENT OF GOODS.

Goods shall comply with the specifications for material, workmanship and performance. Unless otherwise specified, the warranty shall be for a period of 18 months from the date of receipt. If the delivery is found non-compliant during the warranty period, leading to rejection, the Seller shall arrange free replacement / repair of goods, within one month from the date of intimation or any mutually agreed period. The rejected goods shall be taken away by the Seller at his cost and

replaced on Delivered Duty Paid (DDP) (FOR - BHEL Stores / designated destination basis) within such period. In the event of the Seller's failure to comply, Purchaser may take action as appropriate, including Repair / Replenish rejected goods & disposal of rejections, at the risk & cost of the Seller. In case the defects attributable to Seller are detected during processing of the goods at BHEL or at our subcontractor's works, the Seller shall be responsible for free replacement / repair of the goods as required by BHEL.

- b) **RETURN OF REJECTED MATERIAL FOR REPLACEMENT:** The bidder shall have to pay 5% incidental charges while taking back supplied material if it is found rejected on receipt. The rejected material shall be sent back only after receipt of replacement / submission of BG / refund of amount paid.

14. QUALITY REQUIREMENT.

Your bid / quotation should have specific confirmation regarding meeting all our quality requirements such as. (i) Test Certificate (TC), (ii) Guarantee Certificate (GC) / Warranty Certificate (WC), (iii) Quality Plan (QP) (if applicable); and (iv) Pre-Dispatch Inspection at your works (if applicable).

15. VALIDITY.

The quotation should be valid for a minimum period of 90 days effective from the date of opening of tender, unless otherwise specified in the tender enquiry.

16. RIGHT OF ACCEPTANCE.

- a) **BHARAT HEAVY ELECTRICALS LIMITED HARIDWAR** reserves the right to reject any or all the bids / quotations without assigning any reason thereof. BHEL also reserves the right to increase or decrease the tendered quantities. Bidders should be prepared to accept order for reduced quantity without any extra charges.
- b) Any discount / revised offer / bids submitted by a bidder on its own shall be considered, provided it is received on or before the due date and time of offer / bid submission (Part-1). Conditional discounts shall not be considered for evaluation of tenders.



BHARAT HEAVY ELECTRICALS LIMITED

HEEP-HARIDWAR, UTTARAKHAND (249403)

General Instructions and Standard Terms & Conditions for bidding against Tender Enquiry (GISTC)

For Indian Bidders (Version June-2021, Rev: 06)

- c) Unsolicited discounts / revised offers / bids given after Part-1 bid opening shall not be accepted. No change in price will be permitted within the validity period asked for in the tender enquiry.
- d) In case of changes in scope and / or technical specification and / or commercial terms & conditions having price implication, techno-commercially acceptable bidders shall be asked by BHEL to submit the impact of such changes on their price bids. In case a bidder opts to submit revised price bid instead of impact called for then the latest price bid shall prevail. However, in both situations, original price bid will be necessarily opened.
- e) The bidder whose bid is technically not accepted will be informed & EMD wherever submitted shall be returned after finalization of contract. EMD shall be forfeited in the event of bidder opting out after tender opening.
- f) BHEL reserves the right to short close the existing Purchase Order / Rate Contract / Work Order or any extension thereof at any stage.

17. TRANSIT INSURANCE.

- a) Transit Insurance will be covered by BHEL under its open Insurance Policy. Seller shall inform dispatch particulars (Purchase Order, RR /GR, Invoice value etc.) to "Finance department (Store bill Section), BHEL Ranipur, Haridwar (Uttarakhand-India) with value of consignment to the Purchaser within 07 days of dispatch for BHEL to arrange insurance coverage in its policy. Failure on the part of seller to inform dispatch particulars will make him liable to pay for any transit damages / losses suffered by the Purchaser.
- b) If Quoted Prices are inclusive of transit insurance, no weightage shall be given while evaluating the bids for Cost of Insurance, being in BHEL Scope.

18. RISK PURCHASE.

In case of abnormal delays (beyond the maximum late delivery period as per LD clause) in supplies / defective supplies or non-fulfillment of any other terms and conditions given in Purchase Order, BHEL may cancel the Purchase Order in full or part thereof, and may also make the purchase of such material from elsewhere / alternative source at the risk and cost of the supplier. BHEL will take all reasonable steps to get the material from alternate source at optimum cost. If bidder does not agree to the above Risk Purchase Clause, BHEL reserves the right to reject the offer. In case for compelling reasons BHEL accepts the offer without acceptance of this clause by the bidder and in the eventuality of Risk Purchase, appropriate action will be taken as per BHEL extant rules. This will be without prejudice to any other right of BHEL under the contract or under General Law.

19. FORCE MAJEURE CLAUSE.

Notwithstanding any other thing contained anywhere else in the contract or PO (Purchase Order), In case the discharge of obligation under the contract by either party is impeded or made unreasonably onerous, neither party shall be considered in breach of the contract to the extent that performance of their respective obligation is prevented by an event of Force Majeure that arises after the effective date (PO date).

In the above clause, Force Majeure means an event beyond the control of the parties to the contract which prevents a party from complying with any obligation of the contract including but not limited to:

- Act of God (Such as but not limited to earthquake, drought, tidal waves, floods etc.).
- War (whether war be declared or not), Hostilities Invasion, Act of foreign enemy etc.
- Rebellion, revolution, insurrection, civil war etc.
- Contamination of Radio Activity from any nuclear fuel or from any other nuclear waste or any other hazardous materials.
- Riots, commotions, strike unless restricted to the employees of supplier.
- Acts of terrorism.



BHARAT HEAVY ELECTRICALS LIMITED

HEEP-HARIDWAR, UTTARAKHAND (249403)

General Instructions and Standard Terms & Conditions for bidding against Tender Enquiry (GISTC)

For Indian Bidders (Version June-2021, Rev: 06)

- g) Other unforeseeable circumstances beyond the control of the parties and which the affected party cannot avoid even by using its best efforts.
- h) Cancellation of contract by customer.
- i) Change in law / government. Regulation making the performance impossible.
- j) Pandemic or Epidemic.

The party claiming to be affected by force majeure shall notify the other party in writing immediately without delay on the intervention and on the cessation of such circumstances.

Irrespective of any extension of time, if an event of force majeure occurs and its effect continues for more than 180 days the affected party shall have right to cancel the contract.

As soon as reasonably practicable following the date of commencement of a Force Majeure Event, and within a reasonable time following the date of termination of a Force Majeure Event, either Party invoking it shall submit to the other Party reasonable proof of the nature of the Force Majeure Event and of its effect upon the performance of the Party's obligations under this Agreement.

The party shall, and shall ensure that its Subcontractors shall, at all times take all reasonable steps within their respective powers and consistent with Good Operating Practices (but without incurring unreasonable additional costs) to:

- a) Prevent Force Majeure Events affecting the performance of the party's obligations under this Agreement.
- b) mitigate the effect of any Force Majeure Event and
- c) Comply with its obligations under this Agreement.

If the war like situation has developed in a country where a seller's works is located in this P.O. or there is political instability and Indian Embassy located in that country forbids or advises for not having any business dealing with the sellers located in such zone / region/ country, then BHEL reserves the right to cancel the order.

20. NON-DISCLOSURE AGREEMENT.

All Drawing and Technical Documents relating to the product or it's manufacture submitted by one party to the other, prior or

subsequent to the formation of contract, shall remain property of the submitting party. Drawing, technical documents or other technical information received by one party, shall not without the consent of the other party, be used for any other purpose than that, for which they were provided. Such technical information shall not without the consent of the submitting party, otherwise be used or copied, reproduced, transmitted or communicated to a third party. Patterns supplied by BHEL will remain BHEL's property which shall be returned by the bidder on demand to BHEL. Bidder shall in no way share or use such intellectual property of BHEL to promote his own business with others or to gain a commercial advantage. BHEL reserves the right to claim damages from the bidder, or take appropriate action as deemed fit against the bidder, for any infringement of the provisions contained herein as available under law or equity.

21. SETTLEMENT OF DISPUTES / ARBITRATION.

In case of any dispute arising out of as in connection with this contract, the same shall be referred to arbitration under Arbitration & Conciliation Act 1996 of a sole arbitrator who shall be appointed by mutual consent of the parties. The seat & venue of arbitration shall be Haridwar.

The proceedings shall be conducted in English. The Governing law of contract shall be the substantive law of India.

22. WHARFAGE / DEMURRAGE RESPONSIBILITY.

In the event of delay in receipt of documents by Manager (Stores-Shipping) BHEL-Haridwar and in case where dispatches are made through Unapproved Transporter the sole responsibility for wharfage / demurrage for such delay shall be that of supplier.

23. CONDITIONS FOR AVAILING MICRO & SMALL ENTERPRISES (MSE'S) BENEFITS.

- a) "MSE Suppliers can avail the intended benefits only if they submit along with the offer, attested copies of either EM II certificate having deemed validity (**five years** from the date of issue of acknowledgement in EM II) or valid NSIC certificate or EM II certificate along with attested copy of a CA certificate



BHARAT HEAVY ELECTRICALS LIMITED

HEEP-HARIDWAR, UTTARAKHAND (249403)

General Instructions and Standard Terms & Conditions for bidding against Tender Enquiry (GISTC)

For Indian Bidders (Version June-2021, Rev: 06)

(Format enclosed at annexure-1 where deemed validity of EM II certificate of five years has expired) applicable for the relevant financial year (latest audited). Date to be reckoned for determining the deemed validity will be the date of bid opening (Part 1 in case of two-part bid) or vendor has to give Udyog Adhar Memorandum (UAM). Non submission of such documents will lead to consideration of their bid at par with other bidders. No benefit shall be applicable for this enquiry if any deficiency in the above required documents is found or the requisite documents are not submitted before price bid opening. If the tender is to be submitted through e-procurement portal, then the above require document are to be uploaded on the portal. Documents should be notarized or attested by a Gazetted officer. **UAM need not required to be notarized or attested.**

b) Any new supplier will be eligible for registration with BHEL as MSE supplier provided at least any one of the following documents are submitted along with application for registration: -

1. Udyog Adhar Memorandum (UAM).
2. Valid National Small Industries Commission (NSIC) Certificate.
3. Entrepreneurs Memorandum part II (EM II) certificate (valid based on deemed validity of 5 years) or
4. EM II certificate along with attested copy of CA Certificate (as per prescribed format at annexure-A) applicable for the relevant financial year (latest audited), where the deemed validity of EM II is over.
5. However, credentials of all MSE suppliers will be verified before advancing the intended benefits.
6. MSE bidders claiming SC/ST status will have to submit SC/ST certificate of the Proprietor from competent authority. Attested (notarized or attested by Gazetted officer) copy to be submitted along with the offer.
7. In case techno-commercial accepted bidders include MSE source and their prices (based on landed cost – considering quoted prices) are within the price band of 15% w.r.t. L-1 bidder, then BHEL can offer **25%** of quantity of respective item (rounded off to nearest number) to MSE bidders at L-1 price and in case, more than one MSE bidder is in 15 % band and the same is accepted by more than one MSE bidders then **25%** quantities of respective items will be considered for ordering on proportionate basis amongst MSE bidders.
8. There will be minimum of **3%** reservation for women owned MSEs within the above mentioned 25% reservation.
9. The reservation for MSEs owned by SC/ST will be **6.25%** { 25% out of target of 25% - refer para 4 of Public Procurement Policy for the Micro and Small Enterprises(MSEs)}.
10. The definition of MSEs owned by Women Entrepreneurs is clarified as under:
 - a) In case of proprietary MSE, proprietor shall be Woman.
 - b) In case of partnership MSE, the Woman partners shall be holding at least 51% of share in the unit.
 - c) In case of Private Limited companies, at least 51% share shall be held by Women promoters.
11. The definition of MSEs owned by SC/ST is clarified as under:
 - a) In case of proprietary MSE, proprietor(s) shall be SC/ST.
 - b) In case of partnership MSE, the SC/ST partners shall be holding at least 51% of shares in the unit.
 - c) In case of Private Limited companies, at least 51% share shall be held by SC/ST promoters.
12. While distributing the **25%** quantity amongst MSE bidders the decimal points in quantity shall be ignored for all the bidders except the L-1 amongst MSE bidders. Balance quantity after allocating the quantity to other MSE bidders ignoring the quantities in decimal, shall be given to L-1 (amongst MSE) bidder. However, if there are more than one MSE bidder at the same price level than preference for additional quantities due to ignoring off the decimal (as mentioned above) shall be given to the bidder offering favorable terms to BHEL and if the conditions offered are also same then preference will be given to the bidder having high SPR rating.
13. In case there are more than one MSE bidders (with different landed cost to BHEL) within 15% price band of lowest bidder and quantity to be offered is 1 no. only, then preference shall be given to the MSE bidder with lowest landed cost.
14. In case there are more than one MSE bidders (with same landed cost to BHEL) within 15% price band of lowest bidder and quantity to be offered is 1 no. only, then preference shall be given first, based on the favorable terms in the bid and in case terms are also same, the bidder with high SPR rating shall be given preference.
15. If L1 bidder is MSE bidder, entire quantity will be given to such MSE bidder only.

Quotations / Bids not in accordance with General Instructions and Standard Terms & Conditions are likely to be ignored.



BHARAT HEAVY ELECTRICALS LIMITED

HEEP-HARIDWAR, UTTARAKHAND (249403)

General Instructions and Standard Terms & Conditions for bidding against Tender Enquiry (GISTIC)

For Indian Bidders (Version June-2021, Rev: 06)

16. Note: It may however be noted that MSE guidelines as on date (Date of Technical Bid Opening Part-1) shall prevail.

17. "As per the OM No. F.No. 1(2)(1)/2016-MA dtd. 09.02.2017 issued from the Office of Development Commissioner (Micro, Small & Medium Enterprises), "Traders and agents should not be allowed to avail the benefits extended under the PP Policy."

In view of this, it is clarified that benefits of MSE (such as EMD Waiver, Tender fee exemption, Price preference, Payment preference etc.) will be given only to those MSE Vendors who are manufacturers of offered items against the NIT. No MSE benefits shall be provided to Agents / Stockists / Dealers / Traders etc. for the items offered but not manufactured by themselves."

24. INFORMATION TO THE BIDDERS.

a) Purchase related information is available at our Business-to-Business (B2B) Portal available on our website <https://hwr.bhel.com>. The user ID & password can be obtained by sending a request to concerned purchase executives.

b) Intimate your change in mail address or communication address or changes, if any, by email to AGM (SDX/MM) giving your bidder Code.

c) Please resolve your rejections and unexecuted overdue purchase order immediately which are posted at our B2B Portal, which can be visited through our site <https://hwr.bhel.com>

d) Copy of this Tender Enquiry is being sent through the post.

e) The Bidder declares that they will not enter into any illegal or undisclosed agreement or understanding, whether formal or informal with other bidder(s). This applies in particular to prices, specifications, certifications, subsidiary contracts, submission or non-submission of bids or any other actions to restrict competitiveness or to introduce cartelization in the bidding process.

In case, the bidder is found having indulged in above activities, suitable action shall be taken by BHEL as per extant policies/guidelines.

f) Supplier must upload digitally signed e-Invoice on B2B portal for processing of Bills.

In other cases, inked signed hard copy of Invoice to be submitted for processing of Bills.

25. MAKE IN INDIA (GOVT-NOTIFICATION).

A. This tender enquiry shall be governed by notification no. P-45021/2/2017-PP (BE-II) dated 04.06.2020 of government of INDIA and subsequent circulars issued afterwards. Accordingly, the minimum local content, the margin of purchase preference and the procedure for preference to make in INDIA shall be adhered.

B. The margin of purchase preference shall be 20%.

- 'Class-I local Supplier' means a supplier or service provider, whose goods, services or works offered for procurement, has local content equal to or more than 50%, as defined under this order.
- 'Class-II local Supplier' means a supplier or service provider, whose goods, services or works offered for procurement, has local content more than 20% but less than 50%, as defined under this order.
- 'Non- local Supplier' means a supplier or service provider, whose goods, services or works offered for procurement, has local content less than or equal to 20%, as defined under this order.

C. Vendor to specifically confirm if they are Class-I or Class-II local supplier or not as per above mentioned notification. Accordingly, the 'Class-I local supplier' / 'Class-II local Supplier' at the time of tender, bidding or solicitation shall be required to indicate percentage of local content and provide self-certification that the item offered meets the local content requirement for 'Class-I local supplier' / 'Class-II local Supplier', as the case may be. They shall also give details of the location(s) at which the local value addition is made.

D. In cases of Procurement for a Value in Excess of Rs. 10 Crores, the 'Class-I local supplier' / 'Class-II local Supplier' shall be required to provide a Certificate from the Statutory Auditor or Cost Auditor of the Company (in the case of companies) or from a practicing Cost Accountant or practicing Chartered Accountant (in respect of suppliers other than companies) giving the percentage of Local Content.



BHARAT HEAVY ELECTRICALS LIMITED

HEEP-HARIDWAR, UTTARAKHAND (249403)

General Instructions and Standard Terms & Conditions for bidding against Tender Enquiry (GISTC)

For Indian Bidders (Version June-2021, Rev: 06)

E. Requirement of Purchase Preference:

Purchase preference shall be given to 'Class-I local supplier' in procurements undertaken by procuring entities in the manner specified hereunder -

a. In the procurements of goods or works, which are covered by para 3(b) of mentioned Govt. circular and which are divisible in nature, the 'class-I local supplier' shall get purchase preference over 'Class-II supplier' as well as 'Non-local supplier', as per following procedure:

- i. Among All qualified bids, the lowest bid will be termed as L1. If L1 is 'Class-I local supplier', the contract for full quantity will be awarded to L1.
- ii. If L1 bid is not a 'Class-I local supplier', 50% of the order quantity shall be awarded to L1. Thereafter, the lowest bidder among the 'Class-I local supplier' will be invited to match the L1 price for the remaining 50% quantity subject to the class-I local supplier's quoted price falling within the margin of purchase preference, and contract for that quantity shall be awarded to such 'Class-I local supplier' subject to matching the L1 price. In case such lowest eligible 'Class-I local supplier' fails to match the L1 price or accepts less than the offered quantity, the next higher 'Class-I local supplier' within the margin of purchase preference shall be invited to match the L1 price for remaining quantity and so on, and contract shall be awarded accordingly. In case some quantity is still left uncovered on Class-I local supplier, then such balance quantity may also be ordered on the L1 bidder".

b. In the procurements of goods or works, which are covered by para 3(b) of mentioned Govt. circular and which are not divisible in nature, and in procurement of services where the bid is evaluated on price alone, the 'class-I local supplier' shall get purchase preference over 'Class-II supplier' as well as 'Non-local supplier', as per following procedure:

- i. Among all qualified bids, the lowest bid will be termed as L1. If L1 is 'Class-I local supplier', the contract will be awarded to L1.
- ii. If L1 is not 'Class-I local supplier', the lowest bidder among the 'Class-I local supplier', will be invited to match the L1 price subject to Class-I local supplier's quoted price falling

within the margin of purchase preference, and the contract shall be awarded to such 'Class-I local supplier' subject to matching the L1 price.

- iii. In case such lowest eligible 'Class-I local supplier', fails to match the L1 price, the 'Class-I local supplier' with the next higher bid within the margin of purchase preference shall be invited to match the L1 price and so on and contract shall be awarded accordingly. In case none of the 'Class-I local supplier' within the margin of purchase preference matches the L1 prices, the contract may be awarded to the L1 bidder.

c. 'Class-II local supplier' will not get purchase preference in any procurement, undertaken by procuring entities.

F. For this procurement, the local content to categorize a supplier as a Class-I local supplier/ Class-II local supplier/ Non-local supplier and purchase preference to Class-I local supplier, is as defined in Public Procurement (Preference to Make in India), Order 2017 dated 04.06.2020 issued by DPIIT. In case of subsequent orders issued by nodal ministry, changing the definition of local content for the items of the NIT, the same shall be applicable even if issued after issue of this NIT, but before opening of Part-II bids against this NIT.

G. Procurements where estimated value to be procured is less than Rs. 5 lakhs shall be exempted from GOI order No. P-45021/2/2017-PP (BE-II) dated 04.06.2020.

H. For procurement of Goods & Services which are divisible in nature, following shall be operated for **MSE bidders** under Public procurement Policy for the Micro and Small Enterprises (MSEs) Amendment Order, 2019, Ref. No. AA:SSP: MSE: Amndt, dtd. 30.11.2018, Circular No. 44 of 2018-19;-

a. If L1 bid is not from "Class-I local Supplier" and price quoted by MSE bidder falls within the margin of Purchase preference (L1+15% for MSEs), then 25 % of total order quantity of respective item (rounded off to nearest number) shall be awarded to MSE bidder, subject to MSE bidder matching the L1 Price. Out of Remaining 75% quantity, distribution shall be operated as per below sub-clause (2) –

b. If "Class- I Local Supplier" (Next to L1, other than MSE) quoted price falling within the Margin of Purchase Preference, and "Class-I local supplier" matches the L1 price,



BHARAT HEAVY ELECTRICALS LIMITED

HEEP-HARIDWAR, UTTARAKHAND (249403)

General Instructions and Standard Terms & Conditions for bidding against Tender Enquiry (GISTC)

For Indian Bidders (Version June-2021, Rev: 06)

then 50% of remaining Quantity (after allocation of 25% to MSE) i.e. 37.5% shall be awarded to local supplier and 37.5% shall be awarded to foreign bidder.

Note: L1 Price refers to lowest evaluated / landed cost to Company.

For Further details, please refer GOI order no. P-45021 / 2 / 2017 - PP (BE-II) dated 04.06.2020.

26. RESTRICTIONS UNDER RULE 144(XI) OF THE GENERAL FINANCIAL RULES (GFRs), 2017

All provisions of Order No. F.No.6/18/2019-PPD of Department of Expenditure (DoE) shall be applicable for this tender enquiry (Order copy is available at <https://doe.gov.in/procurement-policy-divisions>). Accordingly, any bidder from a country which shares a land border with India (except the countries to which the Govt. of India has extended lines of credit or in which the Govt. of India is engaged in development projects for which list is available at <https://www.mea.gov.in/>) will be eligible to bid in this tender only if the bidder is registered with the Competent Authority as specified in Annex I of the said Order of DoE.

Updated list of the countries to which lines of credit have been extended or in which development projects are undertaken are available on the Ministry of External affairs website (<https://www.mea.gov.in/>)

For the purpose of this order, definition of Bidder from a country which shares a land border with India shall be same as defined in the Annex III of the said order.

Registration with the competent authority as stipulated in the said order is responsibility of bidder. Bidder has to submit a certificate certifying following along with offer:

"I have read the clause regarding restrictions on procurement from a bidder of a country which shares a land border with India; I certify that bidder (.... Name of Bidder) is not from such a country or, if from such a country, has been registered with the Competent Authority. I hereby certify that bidder (.....Name of bidder) fulfils all requirements in this regard and is eligible to be considered"

If the bidder is from such country which shares a land border with India evidence of valid registration by the Competent Authority shall also be attached along with offer."

27. NOTE.

- a) Special conditions of enquiry, if enclosed by BHEL, will supersede the respective standard / general terms of enquiry.
- b) Any other Standard terms and Conditions of the bidder attached / referred against the tender enquiry will be treated as null and void ab initio.
- c) In order to protect the commercial interests of BHEL, it becomes necessary to take action against suppliers / contractors by way of suspension of business dealings, who either fail to perform or are in default without any reasonable cause, cause loss of business / money / reputation, indulged in malpractices, cheating, bribery, fraud or any other misconducts or formation of cartel so as to influence the bidding process or influence the price etc. Guide- lines for Suspension of Business Dealings with Suppliers / Contractors shall prevail over which is available at BHEL website <http://www.bhel.com>
- d) The bidder along with its associate / collaborators / sub-contractors / sub-vendors / consultants / service providers shall strictly adhere to BHEL Fraud Prevention Policy displayed on BHEL website <http://www.bhel.com> and shall immediately bring to the notice of BHEL-Management about any fraud or suspected fraud as soon as it comes to their notice.
- e) "BHEL shall recover the amount of compensation paid to victim(s) by BHEL towards loss of life / permanent disability due to an accident which is attributable to the negligence of contractor, agency or firm or any of its employees as detailed below;
 1. **Victim:** Any person who suffers permanent disablement or dies in an accident as defined below.
 2. **Accident:** Any death or permanent disability resulting solely and directly from any unintended and unforeseen injurious

Quotations / Bids not in accordance with General Instructions and Standard Terms & Conditions are likely to be ignored.



BHARAT HEAVY ELECTRICALS LIMITED

HEEP-HARIDWAR, UTTARAKHAND (249403)

General Instructions and Standard Terms & Conditions for bidding against Tender Enquiry (GISTC)

For Indian Bidders (Version June-2021, Rev: 06)

occurrence caused during the manufacturing / operation and works incidental thereto at BHEL factories/ **offices and precincts** thereof , project execution , erection and commissioning, services, repairs and maintenance, trouble shooting, serving , overhaul, renovation and retrofitting , trial operation, performance guarantee testing undertaken by the company or during any works / during working at BHEL Units/ Offices/ townships and premises/ project sites.

3. Compensation in respect of each of the victims:

- (i) In the event of death or **permanent disability** resulting from **Loss of both limbs**: Rs. 10,00,000/- (Rs. Ten Lakh).
- (ii) In the event of **other permanent disability**: Rs. 7,00,000/- (Rs. Seven Lakh).

4. Permanent Disablement: A disablement that is classified as a permanent total disablement under the proviso to Section 2(l) of the Employees Compensation Act, 1923.”

f) The bidder shall be in compliance with applicable laws, rules and regulations throughout the terms of the contract for conducting its business generally and to perform its obligations under this contract.

Format for Self Certification under preference to Make in India order

Certificate

In line with Government Public Procurement Order No. P-45021/2/2017-PP (BE-II) dated 04.06.2020, we hereby certify that we M/s _____ (supplier name) are local supplier. The percentage of local content in the items _____ offered by us against Enquiry No. _____ is _____% (percentage).

Details of location at which local value addition will be made is as follows:

We also understand, false declarations will be in breach of the Code of Integrity under Rule 175(1)(i)(h) of the General Financial Rules for which a bidder or its successors can be debarred for up to two years as per Rule 151 (iii) of the General Financial Rules along with such other actions as may be permissible under law.

Sign & Stamped of the supplier

BANK GUARANTEE FOR PERFORMANCE SECURITY

Bank Guarantee No:

Date:

To
NAME
& ADDRESSES OF THE BENEFICIARY

Dear Sirs,

In consideration of Bharat Heavy Electricals Limited (hereinafter referred to as the 'Employer' which expression shall unless repugnant to the context or meaning thereof, include its successors and permitted assigns) incorporated under the Companies Act, 1956 and having its registered office at _____¹ through its Unit at.....(name of the Unit) having awarded to (Name of the Vendor / Contractor / Supplier) with its registered office at _____² hereinafter referred to as the 'Vendor / Contractor / Supplier ', which expression shall unless repugnant to the context or meaning thereof, include its successors and permitted assigns), a contract Ref No.....dated³ valued at Rs.....⁴ (Rupees -----)/FC.....(in words.....) for⁵ (hereinafter called the 'Contract') and the Vendor / Contractor / Supplier having agreed to provide a Contract Performance Bank Guarantee, equivalent to% (.... Percent) of the said value of the Contract to the Employer for the faithful performance of the Contract,

we,, (hereinafter referred to as the Bank), having registered/Head office at and inter alia a branch at being the Guarantor under this Guarantee, hereby, irrevocably and unconditionally undertake to forthwith and immediately pay to the Employer any sum or sums upto a maximum amount of Rs -- -----⁶ (Rupees -----) without any demur, immediately on first demand from the Employer and without any reservation, protest, and recourse and without the Employer needing to prove or demonstrate reasons for its such demand.

Any such demand made on the Bank shall be conclusive as regards the amount due and payable by the Bank under this guarantee. However, our liability under this guarantee shall be restricted to an amount not exceeding Rs. _____.

We undertake to pay to the Employer any money so demanded notwithstanding any dispute or disputes raised by the Vendor / Contractor / Supplier in any suit or proceeding pending before any Court or Tribunal, Arbitrator or any other authority, our liability under this present being absolute and unequivocal.

The payment so made by us under this Guarantee shall be a valid discharge of our liability for payment thereunder and the Vendor / Contractor / Supplier shall have no claim against us for making such payment.

We thebank further agree that the guarantee herein contained shall remain in full force and effect during the period that would be taken for the performance of the said Contract/satisfactory completion of the performance guarantee period as per the terms of the Contract and that it shall continue to be enforceable till

all the dues of the Employer under or by virtue of the said Contract have been fully paid and its claims satisfied or discharged.

WeBANK further agree with the Employer that the Employer shall have the fullest liberty without our consent and without affecting in any manner our obligations hereunder to vary any of the terms and conditions of the said Contract or to extend time of performance by the said Vendor / Contractor / Supplier from time to time or to postpone for any time or from time to time any of the powers exercisable by the Employer against the said Vendor / Contractor / Supplier and to forbear or enforce any of the terms and conditions relating to the said Contract and we shall not be relieved from our liability by reason of any such variation, or extension being granted to the said Vendor / Contractor / Supplier or for any forbearance, act or omission on the part of the Employer or any indulgence by the Employer to the said Vendor / Contractor / Supplier or by any such matter or thing whatsoever which under the law relating to sureties would but for this provision have effect of so relieving us.

The Bank also agrees that the Employer at its option shall be entitled to enforce this Guarantee against the Bank as a principal debtor, in the first instance without proceeding against the Vendor / Contractor / Supplier and notwithstanding any security or other guarantee that the Employer may have in relation to the Vendor / Contractor / Supplier 's liabilities.

This Guarantee shall remain in force upto and including.....⁷ and shall be extended from time to time for such period as may be desired by Employer.

This Guarantee shall not be determined or affected by liquidation or winding up, dissolution or change of constitution or insolvency of the Vendor / Contractor / Supplier but shall in all respects and for all purposes be binding and operative until payment of all money payable to the Employer in terms thereof.

Unless a demand or claim under this guarantee is made on us in writing on or before the⁸we shall be discharged from all liabilities under this guarantee thereafter.

We, BANK lastly undertake not to revoke this guarantee during its currency except with the previous consent of the Employer in writing.

Notwithstanding anything to the contrary contained hereinabove:

- a) The liability of the Bank under this Guarantee shall not exceed.....⁶
- b) This Guarantee shall be valid up to⁷
- c) Unless the Bank is served a written claim or demand on or before⁸ all rights under this guarantee shall be forfeited and the Bank shall be relieved and discharged from all liabilities under this guarantee irrespective of whether or not the original bank guarantee is returned to the Bank.

We, _____ Bank, have power to issue this Guarantee under law and the undersigned as a duly authorized person has full powers to sign this Guarantee on behalf of the Bank.

For and on behalf of
(Name of the Bank)

Dated.....

Place of Issue.....

INTEGRITY PACT**Between**

Bharat Heavy Electricals Ltd. (BHEL), a company registered under the Companies Act 1956 and having its registered office at "BHEL House", Siri Fort, New Delhi - 110049 (India) hereinafter referred to as "The Principal", which expression unless repugnant to the context or meaning hereof shall include its successors or assigns of the ONE PART

and

_____, (description of the party along with address), hereinafter referred to as "The Bidder/ Contractor" which expression unless repugnant to the context or meaning hereof shall include its successors or assigns of the OTHER PART

Preamble

The Principal intends to award, under laid-down organizational procedures, contract/s for

_____. The Principal values full compliance with all relevant laws of the land, rules and regulations, and the principles of economic use of resources, and of fairness and transparency in its relations with its Bidder(s)/ Contractor(s).

In order to achieve these goals, the Principal will appoint Independent External Monitor(s), who will monitor the tender process and the execution of the contract for compliance with the principles mentioned above.

Section 1- Commitments of the Principal

1.1 The Principal commits itself to take all measures necessary to prevent corruption and to observe the following principles:-

1.1.1 No employee of the Principal, personally or through family members, will in connection with the tender for, or the execution of a contract, demand, take a promise for or accept, for self or third person, any material or immaterial benefit which the person is not legally entitled to.

1.1.2 The Principal will, during the tender process treat all Bidder(s) with equity and reason. The Principal will in particular, before and during the tender process, provide to all Bidder(s) the same information and will not provide to any Bidder(s) confidential/ additional information through which the Bidder(s) could obtain an advantage in relation to the tender process or the contract execution.

1.1.3 The Principal will exclude from the process all known prejudiced persons.

1.2 If the Principal obtains information on the conduct of any of its employees which is a penal offence under the Indian Penal Code 1860 and Prevention of Corruption Act 1988 or any other statutory penal enactment, or if there be a substantive suspicion in this regard, the Principal will inform its Vigilance Office and in addition can initiate disciplinary actions:

Section 2 - Commitments of the Bidder(s)/ Contractor(s)

- 2.1 The Bidder(s)/ Contractor(s) commit himself to take all measures necessary to prevent corruption. He commits himself to observe the following principles during his participation in the tender process and during the contract execution.
- 2.1.1 The Bidder(s)/ Contractor(s) will not, directly or through any other person or firm, offer, promise or give to the Principal or to any of the Principal's employees involved in the tender process or the execution of the contract or to any third person any material, immaterial or any other benefit which he/ she is not legally entitled to, in order to obtain in exchange any advantage of any kind whatsoever during the tender process or during the execution of the contract.
- 2.1.2 The Bidder(s)/ Contractor(s) will not enter with other Bidder(s) into any illegal or undisclosed agreement or understanding, whether formal or informal. This applies in particular to prices, specifications, certifications, subsidiary contracts, submission or non-submission of bids or any other actions to restrict competitiveness or to introduce cartelization in the bidding process.
- 2.1.3 The Bidder(s)/ Contractor(s) will not commit any penal offence under the relevant Indian Penal Code (IPC) and Prevention of Corruption Act; further the Bidder(s)/ Contractor(s) will not use improperly, for purposes of competition or personal gain, or pass on to others, any information or document provided by the Principal as part of the business relationship, regarding plans, technical proposals and business details, including information contained or transmitted electronically.
- 2.1.4 Foreign Bidder(s)/ Contractor(s) shall disclose the name and address of agents and representatives in India and Indian Bidder(s)/ Contractor(s) to disclose their foreign principals or associates. The Bidder(s)/ Contractor(s) will, when presenting his bid, disclose any and all payments he has made, and is committed to or intends to make to agents, brokers or any other intermediaries in connection with the award of the contract.
- 2.2 The Bidder(s)/ Contractor(s) will not instigate third persons to commit offences outlined above or be an accessory to such offences.
- 2.3 The Bidder(s)/ Contractor(s) shall not approach the Courts while representing the matters to IEMs and will await their decision in the matter.

Section 3 - Disqualification from tender process and exclusion from future contracts

If the Bidder(s)/ Contractor(s), before award or during execution has committed a transgression through a violation of Section 2 above, or acts in any other manner such as to put his reliability or credibility in question, the Principal is entitled to disqualify the Bidder(s)/ Contractor(s) from the tender process or take action as per the separate "Guidelines on Banning of Business dealings with Suppliers/ Contractors", framed by the Principal.

Section 4 - Compensation for Damages

- 4.1 If the Principal has disqualified the Bidder from the tender process prior to the award according to Section 3, the Principal is entitled to demand and recover the damages equivalent Earnest Money Deposit/ Bid Security.
- 4.2 If the Principal has terminated the contract according to Section 3, or if the Principal is entitled to terminate the contract according to section 3, the Principal shall be entitled to

demand and recover from the Contractor liquidated damages equivalent to 5% of the contract value or the amount equivalent to Security Deposit/ Performance Bank Guarantee, whichever is higher.

Section 5 - Previous Transgression

- 5.1 The Bidder declares that no previous transgressions occurred in the last 3 years with any other company in any country conforming to the anti-corruption approach or with any other Public Sector Enterprise in India that could justify his exclusion from the tender process.
- 5.2 If the Bidder makes incorrect statement on this subject, he can be disqualified from the tender process or the contract, if already awarded, can be terminated for such reason.

Section 6 - Equal treatment of all Bidders/ Contractors / Sub-contractors

- 6.1 The Principal will enter into agreements with identical conditions as this one with all Bidders and Contractors. In case of sub-contracting, the Principal contractor shall be responsible for the adoption of IP by his sub-contractors and shall continue to remain responsible for any default by his sub-contractors.
- 6.2 The Principal will disqualify from the tender process all bidders who do not sign this pact or violate its provisions.

Section 7 - Criminal Charges against violating Bidders/ Contractors /Subcontractors

If the Principal obtains knowledge of conduct of a Bidder, Contractor or Subcontractor, or of an employee or a representative or an associate of a Bidder, Contractor or Subcontractor which constitutes corruption, or if the Principal has substantive suspicion in this regard, the Principal will inform the Vigilance Office.

Section 8 - Independent External Monitor(s)

- 8.1 The Principal appoints competent and credible Independent External Monitor for this Pact. The task of the Monitor is to review independently and objectively, whether and to what extent the parties comply with the obligations under this agreement.
- 8.2 The Monitor is not subject to instructions by the representatives of the parties and performs his functions neutrally and independently. He reports to the CMD, BHEL.
- 8.3 The Bidder(s)/ Contractor(s) accepts that the Monitor has the right to access without restriction to all contract documentation of the Principal including that provided by the Bidder(s)/ Contractor(s). The Bidder(s)/ Contractor(s) will grant the monitor, upon his request and demonstration of a valid interest, unrestricted and unconditional access to his contract documentation. The same is applicable to Sub-contractor(s). The Monitor is under contractual obligation to treat the information and documents of the Bidder(s)/ Contractor(s) / Sub-contractor(s) with confidentiality in line with Non- disclosure agreement.
- 8.4 The Principal will provide to the Monitor sufficient information about all meetings among the parties related to the contract provided such meetings could have an impact on the contractual relations between the Principal and the Contractor. The parties offer to the Monitor the option to participate in such meetings.

- 8.5 The role of IEMs is advisory, would not be legally binding and it is restricted to resolving issues raised by an intending bidder regarding any aspect of the tender which allegedly restricts competition or bias towards some bidders. At the same time, it must be understood that IEMs are not consultants to the Management. Their role is independent in nature and the advice once tendered would not be subject to review at the request of the organization.
- 8.6 For ensuring the desired transparency and objectivity in dealing with the complaints arising out of any tendering process, the matter should be examined by the full panel of IEMs jointly as far as possible, who would look into the records, conduct an investigation, and submit their joint recommendations to the Management.
- 8.7 The IEMs would examine all complaints received by them and give their recommendations/ views to CMD, BHEL, at the earliest. They may also send their report directly to the CVO and the Commission, in case of suspicion of serious irregularities requiring legal/ administrative action. IEMs will tender their advice on the complaints within 10 days as far as possible.
- 8.8 The CMD, BHEL shall decide the compensation to be paid to the Monitor and its terms and conditions.
- 8.9 IEM should examine the process integrity, they are not expected to concern themselves with fixing of responsibility of officers. Complaints alleging mala fide on the part of any officer of the organization should be looked into by the CVO of the concerned organisation.
- 8.10 If the Monitor has reported to the CMD, BHEL, a substantiated suspicion of an offence under relevant Indian Penal Code/ Prevention of Corruption Act, and the CMD, BHEL has not, within reasonable time, taken visible action to proceed against such offence or reported it to the Vigilance Office, the Monitor may also transmit this information directly to the Central Vigilance Commissioner, Government of India.
- 8.11 The number of Independent External Monitor(s) shall be decided by the CMD, BHEL.
- 8.12 The word 'Monitor' would include both singular and plural.

Section 9 - Pact Duration

- 9.1 This Pact shall be operative from the date IP is signed by both the parties till the final completion of contract for successful bidder and for all other bidders 6 months after the contract has been awarded. Issues like warranty / guarantee etc. should be outside the purview of IEMs.
- 9.2 If any claim is made/ lodged during currency of IP, the same shall be binding and continue to be valid despite the lapse of this pact as specified above, unless it is discharged/ determined by the CMD, BHEL.

Section 10 - Other Provisions

- 10.1 This agreement is subject to Indian Laws and jurisdiction shall be registered office of the Principal, i.e. New Delhi.

- 10.2 Changes and supplements as well as termination notices need to be made in writing. Side agreements have not been made.
- 10.3 If the Contractor is a partnership or a consortium, this agreement must be signed by all partners or consortium members.
- 10.4 Should one or several provisions of this agreement turn out to be invalid, the remainder of this agreement remains valid. In this case, the parties will strive to come to an agreement to their original intentions.
- 10.5 Only those bidders / contractors who have entered into this agreement with the Principal would be competent to participate in the bidding. In other words, entering into this agreement would be a preliminary qualification.

For & On behalf of the Principal

For & On behalf of the Bidder/

Contractor

(Office Seal)

(Office Seal)

Place-----

Date-----

Witness:_____

Witness:_____

(Name & Address) _____

(Name & Address) _____

Clause on IP in the tender**“Integrity Pact (IP)”**

- (a) IP is a tool to ensure that activities and transactions between the Company and its Bidders/ Contractors are handled in a fair, transparent and corruption free manner. Following Independent External Monitors (IEMs) on the present panel have been appointed by BHEL with the approval of CVC to oversee implementation of IP in BHEL.

Sl	IEM	Address	Phone & Email
1.	Shri D.R.S Chaudhary, IAS (Retd.)	E-1/164, Arera Colony Bhopal 462016 (M.P.)	dilip.chaudhary@icloud.com
2.	Mrs. Pravin Tripathi, IA & AS (Retd.)	D-243, Anupam Gardens, Lane IB, Neb Sarai, Sainik Farms, New Delhi – 110 068	pravin.tripathi@gmail.com

- (b) The IP as enclosed with the tender is to be submitted (duly signed by authorized signatory) along with techno-commercial bid (Part-I, in case of two/ three part bid). Only those bidders who have entered into such an IP with BHEL would be competent to participate in the bidding. In other words, entering into this Pact would be a preliminary qualification.
- (c) Please refer Section-8 of IP for Role and Responsibilities of IEMs. In case of any complaint arising out of the tendering process, the matter may be referred to any of the above IEM(s). All correspondence with the IEMs shall be done through email only.

Note:

No routine correspondence shall be addressed to the IEM (phone/ post/ email) regarding the clarifications, time extensions or any other administrative queries, etc on the tender issued. All such clarification/ issues shall be addressed directly to the tender issuing (procurement) department's officials whose contact details are provided below:

Details of contact person(s):

(1)
Name: _____
Deptt: _____
Address: _____
Phone: (Landline/ Mobile) _____
Email: _____
Fax: _____

(2)
Name: _____
Deptt: _____
Address: _____
Phone: (Landline/ Mobile) _____
Email: _____
Fax: _____

NON-DISCLOSURE AND PROPRIETARY INFORMATION AGREEMENT

BETWEEN

_____ (**Name of the Vendor**), having its registered offices in _____ (**Address of Vendor**), registered under the no. _____ of the Companies' register of _____ (**Name of Place and Country**), capital stock of _____ (**Value**), with a place of business in _____ (**Name of Place and Country**) (hereinafter referred to as

" _____ (**Name of Vendor**)" **which expression shall unless repugnant to the context or meaning thereof , includes its successors in interest and assigns.**

AND

Bharat Heavy Electricals Ltd a company incorporated under the Indian Companies Act 1956 having its registered offices at BHEL House, Siri Fort, New Delhi -110 049 and having one of its works at Heavy Electrical Equipment Plant, Ranipur, Haridwar-249403 (Uttarakhand), India registered under the No. 4281 of 1964-65 of the companies register of Delhi, capital stock of Rs 4895.2 million with a place of registered office in New Delhi (hereinafter referred to as "BHEL") hereinafter also referred to individually as "the Party" or collectively as "the Parties" **which expression shall unless repugnant to the context or meaning thereof , includes its successors in interest and assigns.**

BACKGROUND

This Agreement sets forth the rights and obligations of the Parties with respect to the use, handling, protection and safeguarding of Proprietary Information that is disclosed by and between the Parties.

WHEREAS

- A) the Parties wish to pursue exploratory discussions concerning a possible collaboration between them in relation to the Program defined in Exhibit 1;
- B) during the ensuing discussions and negotiations it may occur that either Party discloses to the other technical, financial or business information of a proprietary or confidential nature, which the Parties intend to protect against, making it available, by any means to any third person, and other unauthorized use and/or further disclosure by the recipient, in accordance with the terms and conditions set forth herein;

NOW, THEREFORE, the Parties have agreed as follows:

1. The term "Proprietary Information" shall mean any information or data of whatsoever kind of a confidential or proprietary nature,

including but not limited to, commercial information, know how and technical information trade secrets, IPR, brand name, marketing plan & all other non-public information in the form of designs, drawings, concepts, requirements, specifications, software, interfaces, components, processes, or the like, that have been or will be disclosed by either Party to the other pursuant to this Agreement, either in writing, orally or other form, which is designated as “Proprietary” or “Confidential” by the disclosing Party by means of formal declaration or an appropriate stamp, legend or any other written or orally notice .

2. Proprietary Information may be conveyed, without limitation, through any written or printed documents, samples, models, electronic form on disk, tape, other storage media or any other means of disclosing such Proprietary Information that either Party may elect to use during the life of this Agreement, but if an originating Party originally discloses information orally or visually, the receiving Party will protect such information as Proprietary Information to the extent that the originating Party : - identifies the Information as Proprietary at the time of original disclosure, - summarizes the Proprietary Information in writing .

Information stored in electronic form on disk, tape, other storage media will be adequately marked if a proprietary legend displays when the information originally runs on a computer system and when the information is printed from its data file. Proprietary Information also includes any information which can be obtained by examination, testing or analysis of any hardware or material substance or any component part of such hardware or material substance provided by the Disclosing Party even though the requirements in Clause 1 for marking and designation have not been fulfilled.

3. Each Party, to the extent of its rights to do so, shall disclose to the other only the Proprietary Information which the disclosing Party deems appropriate to fulfil the objectives of this Agreement. The Parties hereby represent that the disclosure of Proprietary Information by and between themselves shall be made in compliance with, and subject to the laws and regulations of the Disclosing Party's country.
4. The receiving Party hereby agrees and covenants that, from the effective date of this Agreement until the expiry date as per article 11 and the following period as per article 12, the Proprietary Information that either Party receives from the other shall:
 - a) be protected and kept in strict confidence by the receiving Party which must use the same degree of care it uses to protect its own confidential information and in no case less than a reasonable care;

- b) be only disclosed to and used by those persons within the receiving Party's organization who have a need to know and solely for the purposes specified in this Agreement, and be treated by such persons or entities with the same degree of care and subject to the same restrictions;
- c) to procure that each third party to whom Proprietary Information is disclosed under this Agreement is made aware of the provisions of this Agreement prior to such disclosure to it and that each such third party is bound by obligations of confidentiality which are no less onerous than those contained in this Agreement;
- d) neither be disclosed nor caused to be disclosed or made available, either directly or indirectly, to any third Party or persons other than those mentioned in subparagraph b) above or other persons upon which both of the contractual Parties shall agree in an amendment to this Agreement;
- e) not to copy, reproduce or reduce to writing any part of such Proprietary Information except as may be reasonably necessary for the purpose referred to in the Recitals of this Agreement

PROVIDED THAT the Receiving Party shall be entitled to make any disclosure required by court order or government or regulatory requirement of the Disclosing Party's Proprietary Information subject to notifying the Disclosing Party as soon as possible of such requirement

- 5. Any Proprietary Information and copies thereof disclosed by either Party to the other shall remain the property of the disclosing Party and shall be immediately returned or destroyed by the receiving Party upon request, or upon expiry of this agreement.
- 6. The receiving Party shall have no obligations or restrictions with respect to any Proprietary Information for which the receiving Party can prove that:
 - a) is in or which comes into the public domain otherwise than as a result of a breach of this Agreement by any person to whom a disclosure of Proprietary Information is made as permitted under this Agreement or of any other duty of confidentiality relating to the Proprietary Information of which the Receiving Party has knowledge; or
 - b) it has been in its possession without restriction at the time of the disclosure, as evidenced by written documentation in its files; or
 - c) it has been lawfully received from a third Party without breach of this Agreement;or

- d) it has been or is published without violation of this Agreement; or
 - e) it has been independently developed in good faith by employees of the receiving Party who did not have access to the Proprietary Information; or
 - f) Disclosure of such Proprietary information is required by Law or by a court of competent jurisdiction.
7. With respect to any exchange of Proprietary Information which may occur as a result of this Agreement, it is expressly understood and agreed that the persons listed in Exhibit 2 shall, on behalf of the respective Parties, be the exclusive individuals authorized to receive from and transmit to the other Party Proprietary Information under this Agreement. Each Party may replace at any time its respective authorized individuals identified in such Exhibit 2, within its own organization. Any such new designation by a Party shall be made by written notice to the other at the address indicated in such Exhibit 2.
8. Any Proprietary Information which is identified as “Classified Information”, or whose export is subject to an export license, shall be identified as such by the disclosing Party at the time of disclosure and the disclosure, protection, use and handling thereof, shall remain subject to the security procedures and restrictions imposed by the disclosing Party's Government.
9. The disclosure of Proprietary Information under this Agreement by either Party to the other shall not be construed as granting to the receiving Party any right, whether express or implied by licence or otherwise, on the matters, inventions or discoveries to which such information pertains, or as granting any trademark, patents, copyrights, trade secret right or other form of intellectual property right.
10. Nothing in this Agreement may be construed as an obligation of either Party to disclose any Proprietary Information to the other, or to enter into any subsequent contractual relationship with such other Party.
11. This Agreement covers the exchange of Proprietary Information which may be made by either Party to the other until ten years from signing of the agreement or any extension thereto which may be agreed upon by the Parties in writing. Proprietary information relevant to the Program detailed in Exhibit 1, already made available to the other contractual Party before the effective date, shall also be protected under this Agreement.

It is understood by the parties that, prior to disclosure, the Disclosing Party shall have obtained any government authorisation needed for the export of the Proprietary Information

12. The expiry of the period contemplated in Article 11 of this Agreement shall not relieve the receiving Party from complying with the obligations imposed by Article 4 here above with respect to the use and protection of the Proprietary Information, received prior the date of such expiry, for a period of ten (10) years after such expiry.
13. The Parties are independent contractors. Each will bear all costs and expenses in connection with this Agreement. This Agreement is intended to facilitate only the exchange of Proprietary Information and is not intended to be, and shall not be construed to create a teaming agreement, joint venture, association, partnership, or other business organisation or agency arrangement and no Party shall have the authority to bind the other without the other Party's separate prior written agreement .
14. This Agreement shall be governed by and shall be interpreted in accordance with the substantive Indian laws. Irrespective of the foregoing each Party shall remain bound by the provisions of its own national laws and regulations with respect to the transfer or use of Classified Information or information whose export is subject to an export license.
15. All disputes among the Parties, in connection with or arising out of the existence, validity, construction, performance and termination of this Agreement (or any terms thereof), which the Parties are unable to resolve among themselves, shall be finally settled by an Arbitration. Under the arbitration & Conciliation act 1996 by a sole arbitrator who shall be appointed by mutual consent of the parties. The Arbitration shall be held in Haridwar (India), in English language, in accordance with the rules laid down in the arbitration and reconciliation act of India.
16. The foregoing constitutes the entire Agreement among the Parties with respect to the subject matter hereof and supersedes and cancels all prior representations, negotiations, commitments, undertakings, communications, either oral or written, acceptances, understandings and agreements among the Parties with respect to or in connection with any of the matters to which such Agreement applies or refers.
17. Notices to _____(**Name of Vendor**) shall be made at the following address:

(Complete Address of Vendor)

Attention: Mr. _____(Name of the Authorised Person of Vendor)

Notices to BHEL shall be made at the following address:

BHARAT HEAVY ELECTRICALS LIMITED,
HEAVY ELECTRICAL EQUIPMENT PLANT,
Ranipur, Haridwar-249403 (Uttarakhand), India

Attention: _____(Name of the PPX Incharge)

18. The effective date of this Agreement shall be the date of the last signature appearing herein.

IN WITNESS WHEREOF, each of the Parties has caused this Agreement, to be executed by its duly authorized officer.

19. No failure or delay by either party in exercising or enforcing any right, remedy or power hereunder shall operate as a waiver hereof.

20. In the event that any provisions of this agreement shall be held by a court of competent jurisdiction to be unenforceable, the remaining portions hereof shall remain in full force & effect.

Date :

Signed for and on behalf of

Signed for and on behalf of

(Name of Vendor)

BHEL

By:

By:

Title:

Title:

Signature:

Signature:

EXHIBIT 1

to the

NON-DISCLOSURE AGREEMENT

between

_____ **(Name of Vendor)** and

BHARAT HEAVY ELECTRICALS LIMITED

dated:

The Non Disclosure Agreement covers the exchange of Proprietary Information which may occur during the discussions and negotiations in view of a possible cooperation between the Parties in the following programs:

-Description of Material or Services for which the order is placed

_____ **(Name of Vendor)** list of products that require an exchange of Proprietary Information which may be occur during the discussions and negotiations in view of a possible cooperation for the above programs :

EXHIBIT 2

to the

NON-DISCLOSURE AGREEMENT between

_____ **(Name of Vendor)** and

Bharat Heavy Electricals Ltd.

dated:

Personnel of the Parties authorized to receive and/or transmit Proprietary Information under this Agreement:

For **(Name of Vendor)**

(Name of Person)

Tel.

Fax

Address.

Mr.

Tel.

Fax

Address.

For Bharat Heavy Electricals Ltd.

Mr.

Tel. 01334

Fax 01334

Address. Main Administration Building

BHEL, HEEP, Haridwar

India

Tel. 01334

Fax 01334

Address. Main Administration Building

BHEL, HEEP, Haridwar

India

