



BHEL Tender Enquiry No. B/4011/2025/1627/V2 for the requirement of HPSU WITH SPARES for DOLVI project on GeM Portal

LIST OF ENCLOSURES

	<u>Document</u>	<u>Number of pages</u>
1.	PRE-QUALIFICATION REQUIREMENT	02
2.	WRITE UP OF HPSU FOR TURBINE VALVE	02
3.	BUYER SPECIFIC TERMS & CONDITIONS OF TENDER	18
4.	MADE IN INDIA DECLARATION FORMAT	01
5.	NO DEVIATION FORMAT	01
6.	FCA FORMAT	07
7.	BHEL QP FORMAT	01
	TOTAL PAGES	32

Sachin Gupta (Sr.Engineer/PPX-BOI)
Email: gupta.sachin@bhel.in
Ph. 01334-281670

BUYERS SPECIFIC ADDITIONAL TERMS & CONDITIONS
ITEM NAME: Hydraulic Power Supply Unit of Turbine Valves with its spares
PROJECT: 1X250 MW HSW CPP-4 DOLVI

1. SCOPE OF ENQUIRY:

E-bids on GeM portal are invited from bidders for the supply of **Hydraulic Power Supply Unit of Turbine Valves with its spares** for 1X250 MW HSW CPP-4 DOLVI as per requirement mentioned below:

ITEM-NO	MATERIAL CODE & ITEM DESCRIPTION	QTY.	UNIT	PROJECT	DATE FOR SUPPLY COMPLETION
1	W90311400329 DRG: 11140011000 REV: 00 HPSU WITH FLUSHING DEVICE, COMMISSIONING SPARES AND ACCESSORIES-MAIN TURBINE VALVES	1	SET	DOLVI	28-09-26
2	WS9731140000 DRG: 21140056022 VAR.00 REV: 00 MANDATORY SPARES FOR HYDRAULIC POWER SUPPLY UNIT OF MAIN TURBINE VALVES	1	SET	DOLVI Mandatory spares	28-03-27
3	W99318146477 DRG: 418000E7057 REV:00 CFP MOTOR FOR MAIN HPSU IE3- SUBCRITICAL SETS	1	NO	DOLVI Mandatory spares	28-03-27
4	W99318146485 DRG: 418000E7054 REV:00 CIRCULATION MOTOR FOR MAIN HPSU- IE3 FOR SUCRITICAL PROJE	1	NO	DOLVI Mandatory spares	28-03-27
5	W99318146205 DRG: 418000C8052 REV:00 PRESSURE TRANSMITTER FOR MAIN HPSU	3	NO	DOLVI Mandatory spares	28-03-27
6	W99318146191 DRG: 418000C8052 REV:00 LEVEL TRANSMITTER FOR MAIN HPSU	2	NO	DOLVI Mandatory spares	28-03-27
7	W99318146213 DRG: 418000C8052 REV:00 RTD FOR MAIN HPSU	3	NO	DOLVI Mandatory spares	28-03-27
8	W99318146140 DRG: 418000C8052 REV:00 PRESSURE SWITCH FOR MAIN HPSU	1	NO	DOLVI Mandatory spares	28-03-27
9	W99318146159 DRG: 418000C8052 REV:00 DIFFERENTIAL PRESSURE SWITCH TYPE-1 FOR MAIN HPSU	1	NO	DOLVI Mandatory spares	28-03-27

10	W99318146167 DRG: 418000C8052 REV:00 DIFFERENTIAL PRESSURE SWITCH TYPE-2 FOR MAIN HPSU	1	NO	DOLVI Mandatory spares	28-03-27
11	W99318146175 DRG: 418000C8052 REV:00 DIFFERENTIAL PRESSURE SWITCH TYPE-3 FOR MAIN HPSU	1	NO	DOLVI Mandatory spares	28-03-27
12	W99318146094 DRG: 418000C8052 REV:00 PRESSURE GAUGE TYPE-1 FOR MAIN HPSU	3	NO	DOLVI Mandatory spares	28-03-27
13	W99318146108 DRG: 418000C8052 REV:00 PRESSURE GAUGE TYPE-2 FOR MAIN HPSU	3	NO	DOLVI Mandatory spares	28-03-27
14	W99318146116 DRG: 418000C8052 REV:00 PRESSURE GAUGE TYPE-3 FOR MAIN HPSU	3	NO	DOLVI Mandatory spares	28-03-27
15	W99318146124 DRG: 418000C8052 REV:00 PRESSURE GAUGE TYPE-4 FOR MAIN HPSU	3	NO	DOLVI Mandatory spares	28-03-27

2. Project Detail:

Project Name	ITEMS TO BE DISPATCHED DIRECTLY TO 1X250 MW HSW CPP-4 DOLVI PROJECT
Consignee address	JSW STEEL LIMITED DOLVI WORKS - HSM & LCP P.O-GEETAPURAM, VILLAGE :DOLVI PEN-402107

3. EARNEST MONEY DEPOSIT (EMD):

All interested vendors must submit their e-bid along with the proof of submission of following Earnest Money Deposit (EMD) details in GeM portal along with offer EMD is applicable to all the bidders irrespective of PMD bidders/GeM provisions.

Details	Amount In INR	Type
EMD	INR 6,00,000/- (Six lakhs only)	Refundable

3.1: Modes of deposit: The EMD may be accepted only in the following forms:

- (i) Electronic Fund Transfer credited in BHEL account (before tender opening).
- (ii) Banker's cheque/ Pay order/ Demand draft, in favour of BHEL (along with offer).
- (iii) Fixed Deposit Receipt (FDR).
- (iv) Bank Guarantee from any of the Scheduled Banks.
- (v) Insurance Surety Bonds.
- (vi) The EMD shall remain valid for a period of 45 (forty-five) days beyond the final bid validity period as asked in NIT.

For E-Payment, the RTGS details are as mentioned below:

Bank Details	SWIFT Details of bank	Contact Details of Banker
STATE BANK OF INDIA RANIPUR BRANCH, OPP: BHEL MAIN GATE, SECTOR-5, RANIPUR, HARIDWAR, UTTRAKHAND, INDIA PIN CODE: 249403	SWIFT NO : SBININBB225 CC ACCOUNT NO : 10667995458 IFSC CODE : SBIN0000586	Contact No. +91 1334 224201 +91 1334 226125 Fax: +91 1334 226512

3.2: Exemption of EMD

As per GeM GTC following are the exempted category of EMD/Bid Security.

- a. Micro and Small Enterprises (MSEs) who are holding valid Udyam Registration and are manufacturer of the offered Productor Service (Primary Product / Service - in case of bunch bid with total value wise evaluation) and give specific confirmation to this effect at the time of bid submission and claim EMD exemption and whose credentials are validated online through Udyam Registration website of Ministry of MSME and also through supporting document uploaded during bidding process and validated by the Buyer. State Government Buyers may, however, choose to exempt only MSEs from the State of Bid Inviting Authority by specifying the same in ATC of the Bid. In case no such ATC is included, eligible MSEs of all states are exempted.
- b. Start-ups as recognized by Department for Promotion of Industry and Internal Trade (DPIIT), holding valid Start-up Recognition Certificate which is to be uploaded while bidding and claiming EMD exemption and to be validated by the Buyer. Bidder to ensure that turnover for any of the financial years has not exceeded beyond limits prescribed in the certificate / Start Up scheme of DPIIT.
- c. KVIC, ACASH, WDO, Coir Board, TRIFED and Kendriya Bhandar.
- d. Sellers who have got their credentials verified through the process of Vendor Assessment by Vendor Assessment Agencies for the Primary Product / Primary Service for which Bid / RA has been invited and holding valid Vendor Assessment or Vendor Assessment Exemption Report / confirmation (Seller to upload VA report / VAE confirmation to be validated by the Buyer).
- e. Sellers / Service Provider having annual turnover of INR 500 Crore or more, at least in one of the past three completed financial year(s)
- f. Sellers / Service Providers holding valid BIS License for the Primary Product Category whose credentials are validated through BIS database and through uploaded supporting documents to be validated by the buyer.
- g. Central / State PSUs.
- h. **In addition to above GeM conditions, offers directly from the manufacturer or their authorized agents are also exempted from submission of EMD.**

3.3: Forfeiture of EMD:

- a. A bidder's EMD will be forfeited if the bidder withdraws or amends its/his tender or impairs or derogates from the tender in any respect within the period of validity of the tender or if the successful bidder fails to furnish the required performance security within the specified period mentioned in the Tender.
- b. EMD by the tenderer to be withheld in case any action on the bidder is envisaged under the provisions of extant "Guidelines on Suspension of business dealings with suppliers/ contractors" and forfeited/ released based on the action as determined under these guidelines.
- c. Bid securities of the unsuccessful bidders shall be returned to them after expiry of the final bid validity period / latest by the 30th day after the award of the contract. Since it is a two-part bidding, bid securities of

unsuccessful bidders during first stage i.e. technical evaluation shall be returned within 30 days of declaration of result of first stage i.e. technical evaluation.

- d. Bid security/EMD of the successful bidder shall be returned only on conclusion of the order and receipt of a Performance Security/Performance Bank Guarantee of 10% of contract value (excluding taxes) from contractor / Supplier.
- e. EMD/PBG/PS shall not carry any interest.

BUYERS SPECIFIC ADDITIONAL TERMS & CONDITIONS IN ADDITION TO GTC

Sl. No.	Terms	Description	Supplier confirmation
1.	Documents Checklist:	<p>Please submit signed and stamped copy of your offer on each page along with following documents;</p> <ul style="list-style-type: none"> • Buyer Specific T&C. • Technical PQR & its supportive document. • Technical drawing & purchase specification. • Quality plan. • Certificate/self-certification for minimum local content as per PPP-MII order. • Replica of price bid schedule without prices with part-I offer. <p>Please note that technical documents shall be shared against submission of FCA (FCA copy enclosed) .</p>	
2.	Compliance of GTC on GeM	<p>General Terms and Conditions on GeM 4.0 (Version 1.29) Dtd 25.03.2026 or it's latest revision of GeM portal shall be applicable against this enquiry. Kindly confirm to compliance the same for this tender.</p>	
3.	Pre-Qualification Requirements	<p>The Pre-Qualification Requirements have been compiled. All the bidders should ensure submission of complete details and documents as called for in these requirements. The Offers submitted by the bidders would be scrutinized with respect to Pre-Qualification Requirements first. Techno-Commercial offer of only those bidders shall be evaluated who meet the Pre-Qualification Requirements.</p>	
4.	Procurement from Customer Approved / Accepted Vendors only	<p>Bidders are requested to submit their credentials along with offer (Credentials should include BHEL P.O.s on vendor for the same rating or higher rating turbines, Experience of vendor with state utilities and major PSU like NTPC, End User Certificate wherever available), in order to take up with end customer for approval</p> <p>Supplier to submit following credentials for arranging Customer approval:-</p> <ul style="list-style-type: none"> • Company Profile • List of Order Executed/ on hand for Power Sector/Gov. organization of same /similar items • Copy of Major Supply Orders • Performance Certificates for Satisfactory working of System/ Equipment from end users Item. <p>The offer of only those bidders, who meet Pre-qualification requirement (PQR), Technical requirement and approved by the End Customer, will be considered for price-bid opening for the requirement against this enquiry.</p>	

5.	Make in India Clause	<p>“For this procurement, the local content to categorize a supplier as a Class-I Local Supplier / Class-II Local Supplier/ Non-Local Supplier and purchase preference to Class-I Local Supplier, is as defined in Public Procurement (Preference to Make in India), Order-2017 Ref. No. P-45021/2/2017-PP (BE-II) dtd. 04/06/2020 issued by DPIIT. In case of subsequent orders issued, by the nodal ministry, changing the definition of local content for the items of this NIT, but before opening of Part-II bids against this NIT</p> <p>As per Make in India Order, only Class-1 and Class-2 local supplies are eligible to bid in this tender enquiry.</p> <p>For this eligibility criteria, bidders are required to submit certificate of Minimum local content as specified in attached Make In India Declaration format.</p>	
6.	Compliance of Rule 144 (xi) of GFR 2017	Compliance of Restrictions under Rule 144 (xi) of GFR 2017 shall be as per GeM.	
7.	Bid validity/ Validity of offer	<p>Please note that validity of the offer shall be 180 days from the date opening of Techno-Commercial bid (Part-I bid) on GeM portal.</p> <p>Offer of bidder’s having validity less than 180 days shall liable to reject. Please confirm.</p>	
		<p>The required validity is considering that offer is complete & clear w.r.t. PQR and all techno-commercial conditions. Vendors need to extend their offer validity for the time taken by them in responding BHEL’s comments/clarification sought during techno-commercial scrutiny of the offer. In case regret by any bidder for such validity extension, their offer shall liable to be reject. Please confirm.</p>	
8.	Prices/Basis of Quotation	The offered prices of the items shall remain firm and fixed till execution of the contract.	
		Kindly confirm that your quote prices are inclusive of P&F, Freight & GST for Total quantity on GeM portal.	
		Transit Insurance would be arranged by BHEL. Please quote your prices accordingly.	
		The prices are to be quoted on Ex-Works with freight Pre-paid up to project destination basis. The goods must be dispatched through any Bank approved transporters having their branch at Haridwar. The names and addresses of transporters approved by IBA as well as BHEL are posted at our website www.bhelhwr.co.in . Please note that, if you dispatch the material by any BHEL un-approved transporter then you will necessarily be required to furnish the MRC (Material Receipt Certificate) from respective Project Site for processing of your invoice. No demurrage charges would be borne by BHEL.	
9.	Loading and unloading	<p>Vendor’s scope will not cover Loading & Unloading at Final destination of delivery. Unloading at final destination (i.e. BHEL site) is in BHEL ‘scope.</p> <p>Loading and unloading at other intermediate places due to any permitted transshipment will be the responsibility of the vendor. Kindly note</p>	
10.	Evaluation criteria	Evaluation shall be done on total landed cost upto BHEL Project Site considering all material codes and services together.	
11.	Evaluation Currency	The evaluation currency for this tender shall be INR.	

12.	Payment terms:	<p>For Material Portion;</p> <p>The payment shall be done after receipt of Material at BHEL respective project site, within no. of days as defined in the below table from the date of receipt of Material at site (i.e. MRC date) subject to submission of non-discrepant documents by the vendor, uploading of all documents on BHEL's SUVIDHA portal at the time of dispatch.</p> <table border="1" data-bbox="393 359 1263 527"> <thead> <tr> <th>Type of Bidder</th> <th>Payment Terms (Number of Days)</th> </tr> </thead> <tbody> <tr> <td>Micro & Small Enterprises (MSEs)</td> <td>45 days</td> </tr> <tr> <td>Medium Enterprises</td> <td>60 days</td> </tr> <tr> <td>Non MSME</td> <td>90 days</td> </tr> </tbody> </table> <p>This is in supersession of 10 days' time as provided in Clause 12 of GeM GTC and also 45 days from CRAC as provided in the standard format of GeM Bid under Payment Timelines.</p> <p>For Supervision during E&C of equipment at project site ;</p> <p>100% payment against submission of Successful Commissioning or installation Certificate/Time Sheet/MOM signed by Project authorities along with Invoice direct to BHEL.</p>	Type of Bidder	Payment Terms (Number of Days)	Micro & Small Enterprises (MSEs)	45 days	Medium Enterprises	60 days	Non MSME	90 days	
Type of Bidder	Payment Terms (Number of Days)										
Micro & Small Enterprises (MSEs)	45 days										
Medium Enterprises	60 days										
Non MSME	90 days										
13.	GeM charges	GeM charges if any shall be either side only i.e. buyer's GeM charges shall be in buyer's account and seller's GeM charges shall be on seller's account. Please confirm.									
14.	Contract execution	Bidder's are advised to read GeM related query & clarification carefully on GeM portal. Order shall be executed through GeM.									
15.	Delivery Period	<p>Please quote your lot wise delivery completion period in line with BHEL project site requirement as mentioned in para "1" of this ATC in number of weeks/months from the date of Purchase Order</p> <p>Early delivery w.r.t. above lot delivery will be accepted only after written confirmation from BHEL. BHEL reserve right to reject early delivery request of bidders / suppliers.</p> <p>Delivery period indicated in GeM bid is only indicative and final delivery of tender shall be taken as mentioned in para "1" of this ATC above.</p> <p>Accordingly bidders to confirm the above deliveries or quote their best possible delivery in no of months / weeks from the date of placement of Purchase order, including all activities like document approval, inspection by TPI time etc.,</p>									
16.	Technical Document/ Drawing approval conditions	<p>Drawings/Data sheets/documents/QAP etc. as called for in the specifications shall be submitted by Vendor for BHEL/ Customer approval within 30 days of purchase order. BHEL shall approve these drawings/data sheets/ documents / QAP etc. within 30 days of receipt.</p> <p>Any comments on the documents shall be given by BHEL within 7 days of submission and vendor shall submit revised document / reply to comments, within 7 days of BHEL comments. However, total time for Document approval submission and approval shall not exceed 30 days for respective party.</p> <p>Delivery is from the date of PO, accordingly, delay in submission / revision of the documents by the vendor will automatically account for to vendor. In case of delay on account of BHEL in comments / approval of the documents, the delivery shall</p>									

		be re-scheduled by the no of days taken by BHEL in excess to 30 days. For delay analysis cumulative no of days (including time taken in comments), shall be considered for delivery extension.	
17.	Technical Requirement for Dolvi Project:	Kindly ensure completeness of your offer as per clause-6 OF BHEL SPECIFICATION drawing 11140011000, prior to submission of their offer.	
		Kindly ensure to submit duly filled checklist as per ANNEXURE-C along with your offer.	
		Kindly confirm to provide 3D MODELS for supplied equipment assemblies (having all the components included) complete with all connection points/interfaces for the purpose of 3d power plant layout to be done by BHEL as per customer specification requirements. the file format of 3D model shall be STP	
		Pl note that training program at site for 2 days shall be provided by the vendor regarding design/construction features, operation & maintenance of the supplied equipment (including C&I) to customer / BHEL Engineers.	
		The document no. "CIE-HPSU-I4 REV00" is part of BHEL purchase specification and shall be complied by the vendor., kindly confirm.	
		HPSU documents submitted by supplier for BHEL'S approval shall also be subject to customer's approval. therefore, timely submission of the complete set of HPSU documents must be ensured by the supplier.	
		Documents required after order placement: Kindly confirm that in the event of ordering, you will furnish all the documents as per BHEL DRG. NO. 41140056014 (MDL) complying time schedule mentioned therein. for BHEL review and approval	
18.	PAINTING REQUIREMENTS	<p>IN addition to requirement of clause 3.1.10 OF BHEL specification drawing 41140011001 REV.00, kindly confirm to comply the following quality requirement ;</p> <p>i- EQUIPMENT SHALL BE PAINTED WITH PAINT NOT INFERIOR TO EPOXY RESIN BASED PAINTS WITH MINIMUM DFT OF 150 MICRONS.</p> <p>ii- THE PAINT SHALL BE APPLIED IN THREE STAGES i.e. PRIMER, INTERMEDIAT AND FINISH COATS IN FOLLOWING MANNER: - PRIMER COAT- EPOXY BASED ZINC PHOSPHATE - INTERMEDIATE- EPOXY BASED TIO2 PIGMENTED COAT - FINISH COAT- EPOXY BASED FINISH COAT/TWO PACK POLYURETHANE COAT.</p> <p>iii- SURFACE PREPERATION BEFORE PAINTING SHALL BE CARRIED OUT ACCORDING TO INTERNATIONAL STANDARD.</p>	
19.	Recommended Spares	Please submit item wise price list of each item referred in BHEL Drawing no 2-11400-56015 REV.01 (Recommended Spare Parts).These prices shall be used for our reference and future ordering (if required) and not to be considered for Evaluation.	
20.	Supervision during Erection & Commissioning and Training	<p>Kindly note that supplier to carry out the supervision work during E&C of the equipment. Since there are substantial interfaces of HPSU with EHA's, so bidder to carry out their supervision work at site to ensure satisfactory commissioning of HPSU along with all associated EHA's. for that, kindly Confirm that following charges have been quoted separately in your offer :</p> <ol style="list-style-type: none"> 1. Per Man Day Charges for Training, Supervision during Erection & Commissioning (lump sum & inclusive of everything i.e. lodging, fooding, boarding etc.) 2. Per Visit Charges (to & fro to our site) for Training regarding design/construction features, operation & maintenance of the supplied equipment (Including C&I) to customer's/BHEL Engineers, Supervision during Erection & Commissioning. 	

		<p>A total period of 08 mandays (Inclusive of 02 days training) and 02 Visits will be taken for evaluation purpose for 01 TG Set for Dolvi project. However payment will be made on actual number of man days and visits involved in supervision of erection/ commissioning and training based on the time sheet verified by project site and on the rates quoted in price bid for per mandays & per visits.</p> <p>Please ensure that “Per Man Day” & “Per Visit” charges for Supervision during Erection & Commissioning and Training including every expense are quoted.</p>	
		<p>Please note that the vendor should send a checklist to BHEL prior to deputation of competent representative for Commissioning. BHEL will confirm the checklist prior to issuing Commissioning Call to the vendor. After receipt of checklist from BHEL, the vendor would send the competent representative within 15 days of confirmation of site readiness. <u>In case, any additional work is required which is beyond the scope/warranty/guarantee of the vendor, the work would be commenced only after signed agreements with site representative & the vendor.</u></p>	
		<p>Please confirm that the charges quoted for Supervision during Erection & Commissioning and Training shall be inclusive of applicable GST .</p>	
21.	Packing and Storage	<p>A -Kindly confirm the following packing requirements;</p> <ul style="list-style-type: none"> All the equipments/items shall be supplied in closed steel boxes/closed wooden boxes with steel cover sheet. packing boxes should be rain proof. Kindly confirm. Packaging of item should be done in such a way that it should not require any internal package inspection for at least one year. STORAGE & HANDLING INSTRUCTIONS of the equipment shall be furnished by the vendor separately and 2 copies of the same shall be supplied to site along with main equipment. <p>B-ADDITIONAL PACKING REQUIREMENTS FOR SPARES: 1- ALL spare items shall be packed for 5 year preservation. small spare items shall be packed & sealed in transparent plastic bags and drying agents shall be used. 2- ALL packing box shall be marked properly & numbered clearly. 3- Packing box of mandatory spares shall be painted with green color for easy identification at project sites.</p>	
22.	Special Instructions:	<ul style="list-style-type: none"> Please inform 8 digit HSN code for HPSU along with spares. Mandatory & commissioning spares are to be packed in separate boxes & “Mandatory SPARES” are to be written in bld letters on all sides of packing boxes. Invoice, GR/LR, packing list, Test certificate are required in original for billing to End user. Loose items one marker board needs to be send for each bundle for fixing RFID tag at site. Vendor to ensure submission billing documents in the same month of material dispatch. If vendor fail to provide the despatch documents in the same month GST Penalty shall be applicable and bear by vendor as per GST rule. 	
23.	Liquidated Damages (LD) for late delivery	<p>Liquidated Damages shall be lot wise as per clause no. 15 (iii) of General terms and conditions on GeM 4.0 (Version 1.29) as under: kindly confirm. “If the Seller/Service Provider fails to deliver any or all of the Goods/Services within the original/re-fixed delivery period(s) specified in the contract, the Buyer will be entitled to deduct/recover the Liquidated Damages for the delay, unless</p>	

		covered under Force Majeure conditions aforesaid, @ 0.5% of the contract value of delayed quantity per week or part of the week of delayed period as pre-estimated damages not exceeding 10% of the contract value of delayed quantity without any controversy/dispute of any sort whatsoever".	
		The date of LR would be treated as the date of delivery for penalty purposes.	
24.	MDCC clause	<p>Please note that, material shall be dispatched only after issue of Material dispatch clearance certificate (MDCC) from end customer. For issue of MDCC, vendors are required to submit all test certificates (TC) and inspection report of third party (IR) to BHEL. After review & acceptance of the quality document, BHEL will forward the same to end customer for issuance of MDCC.</p> <p>MDCC shall be issued within 7 days of receipt of complete quality documents / TCs,. In case of delay in issuance of MDCC, only delivery shall be extended by no of days taken by BHEL in excess to 7 days and all other terms and conditions of PO shall remains same & binding.</p> <p>In case any material is dispatched without MDCC and any loss is incurred by Supplier/Vendor for any reason whatsoever, BHEL shall not be responsible in any manner to compensate the supplier in this regard.</p> <p>Kindly confirm.</p>	
25.	Material Verification	<p>The supplier shall depute their representative to site after receipt of material at a suitable point of time to carrying out material verification in presence of BHEL site re-representative , in order to check completeness of supplied equipment. The boxes/ consignment received from supplier will be opened in front of supplier's representative and the content of the packages would be inspected jointly w.r.t. detailed packing list. Any shortage or physical damage shall be identified and recorded in the minutes to be signed with Site/ BHEL Hardwar's representative. Supplier shall depute their representative for this activity within 10 days of receipt of intimation from BHEL without any additional cost, kindly confirm.</p>	
26.	Action against Bidders / vendor / supplier / contractor in case of default:	<p>In order to protect the commercial interests of BHEL, BHEL shall take action against supplies / contractors by way of suspension of business dealings, who either fail to perform or are in default without any reasonable cause, cause loss of business/ money/ reputation, indulge in malpractices, cheating, bribery, fraud or any other misconduct or formation of cartels so as to influence the bidding process or influence the price etc.</p> <p>Suspension of Business Dealings could be in the form of "Hold" or "Banning" a supplier/ contractor or a bidder and shall be as per "Guidelines for Suspension of Business Dealings with Suppliers/ Contractors" available at BHEL's website "https://www.bhel.com/guidelines-suspension-business-dealings-supplierscontractors"</p>	
27.	Guarantee/Warranty clause	<p>Kindly confirm the following Guarantee/Warranty clause;</p> <ul style="list-style-type: none"> • Guarantee/Warranty period shall be provided for a period of 36 months from the date of supply or 18 months from commissioning, whichever is earlier. In case of any failure or trouble reported from site, the supplier should depute their representative immediately to attend the problem and replace the defective component/part if required, without any additional cost to BHEL. • The supplier to provide technical support/services or alternative solutions against any issues; reported in the equipment supplied by the vendor for up to at least 10 years from the supply date. <p>BHEL reserve the rights to reject/load the offers having lesser guarantee period as mentioned above.</p>	

28.	Performance Bank Guarantee	PBG (performance bank guarantee) shall be submitted for 5% of the order value (material portion) lotwise. PBG should be valid for entire Guarantee/ Warranty period. PBG shall be submitted for processing of invoices. Kindly confirm . Lot wise PBG will be acceptable in line with shipment of items.			
29.	Quality Requirement	<p>Kindly confirm the following quality requirement;</p> <ul style="list-style-type: none"> • Kindly submit quality plan in attached BHEL QP format . • In the event of ordering, QP of the successful vendor shall be forwarded to End User for their approval. The supplier to specifically confirm to follow End User approved QP. • Kindly confirm that Inspection shall be done by Third Party Inspection agency & End user as per End User approved quality plan. • For spares items, inspection shall be done as main customer approved QP. for item not appearing in customer approved QP, TC/COC shall be submitted. <p>Inspection charges will be borne by BHEL. All coordination with third party inspection agency shall be done by the supplier only. Inspection call to third party inspection agency may be raised directly by the supplier; however 15 days are to be provided for deputation of representative of third party inspection agency for inspection.</p>			
30.	Dispatch documents	<p>Following dispatch documents to be provided immediately after directly dispatch to BHEL Project site for billing purpose:</p> <ul style="list-style-type: none"> • Guarantee/Warrantee Certificates • E- Invoice • GeM invoice • Original consignee copies of GR/LR/RR (Material shall be dispatched on door delivery basis without consignee copy) • Packing list • Original GST compliance certificate • E-waybill part-B • MRC/POD/Receipted LR/RR/GR copy (as per proof of delivery of material at BHEL Project site) <p><i>All clarification/ issues shall be addressed directly to the tender issuing (procurement) department's officials whose contact details are provided below:</i></p> <table border="1" data-bbox="391 1339 881 1535"> <tr> <td data-bbox="391 1339 881 1535"> Mr. Sachin Gupta Designation: Sr.Engineer (PPX-BOI) 4th Floor, Main Administrative Building, HEEP, BHEL, Hardwar- 249403 Uttarakhand, India Tel: +91 1334 28 1690 </td> <td data-bbox="881 1339 1393 1535"></td> </tr> </table>	Mr. Sachin Gupta Designation: Sr.Engineer (PPX-BOI) 4 th Floor, Main Administrative Building, HEEP, BHEL, Hardwar- 249403 Uttarakhand, India Tel: +91 1334 28 1690		
Mr. Sachin Gupta Designation: Sr.Engineer (PPX-BOI) 4 th Floor, Main Administrative Building, HEEP, BHEL, Hardwar- 249403 Uttarakhand, India Tel: +91 1334 28 1690					
31.	Submission of bills on BHEL SUVIDHA portal	<p>Kindly ensure to necessarily upload the despatch & invoice details on BHEL SUVIDHA portal at https://suvidha.bhel.in/suvidha/, prior to despatch. All documents as per PO checklist , along with additional documents (if any), must be uploaded on the portal. It is mandatory that tax invoices with a net amount (including taxes) exceeding Rs five lakhs uploaded on the portal are digitally signed using a Class 3 Digital Signature Certificate (DSC) issued by a licensed Certifying Authority. Submission of invoice document in hard copy is allowed for invoices with a net amount (including taxes) equal to and upto Rs five lakhs , in case they were not digitally signed and uploaded on the portal. PI note that bill will be registered & processed only after uploading dispatch documents on BHEL SuVIDHA portal.</p>			
32.	Order Acceptance :	<p>Ink signed order acceptance shall be furnished within 15 days of order placement. In case, order acceptance do not received within 15 days of order placement, PO</p>			

		deemed to be accepted by you.	
33.	Beneficiary of PO	Kindly confirm on whom the PO will be placed in the event of ordering.	
34.	Additional Conditions for Assessment	BHEL reserves the right to consider / Not-consider the offers based on the evaluation of documents submitted for the Pre-Qualification Criteria (PQR). BHEL also reserves the right to have on-site assessment of the facilities at supplier's works during the bid evaluation.	
35.	O&M Manuals	Kindly confirm that in the event of ordering O&M manuals will be provided in 19 nos. of Hard Copies and 05 nos portable hard disks of O&M manual as per clause 2.4.1 of BHEL drawing no. 1-11400-56012. Out of these, 16 Nos. Hard Copies & 04 nos portable hard disks of O&M Manuals would be supplied directly to BHEL Haridwar and balance O&M Manuals shall be supplied along with the equipment at site and description of the same should be mentioned in packing list. Kindly note that your documents including O&M Manual shall bear the details as per cover page (Annexure-IV). Further the cover page of the O&M Manual shall be bilingual in Hindi & English Language.	
36.	BREACH OF CONTRACT, REMEDIES AND TERMINATION:	<p>The following shall amount to breach of contract:</p> <p>I. Non-supply of material/ non-completion of work by the Supplier/Vendor within scheduled delivery/ completion period as per contract or as extended from time to time.</p> <p>II. The Supplier/Vendor fails to perform as per the activity schedule and there are sufficient reasons even before expiry of the delivery/ completion period to justify that supplies shall be inordinately delayed beyond contractual delivery/ completion period.</p> <p>III. The Supplier/Vendor delivers equipment/ material not of the contracted quality.</p> <p>IV. The Supplier/Vendor fails to replace the defective equipment/ material/ component as per guarantee clause.</p> <p>V. Withdrawal from or abandonment of the work by the Supplier/Vendor before completion as per contract.</p> <p>VI. Assignment, transfer, subletting of Contract by the Supplier/Vendor without BHEL's written permission resulting in termination of Contract or part thereof by BHEL.</p> <p>VII. Non-compliance to any contractual condition or any other default attributable to Supplier/Vendor.</p> <p>VIII. Any other reason(s) attributable to Vendor towards failure of performance of contract. In case of breach of contract, BHEL shall have the right to terminate the Purchase Order/ Contract either in whole or in part thereof without any compensation to the Supplier/Vendor.</p> <p>IX. Any of the declarations furnished by the contractor at the time of bidding and/ or entering into the contract for supply are found untruthful and such declarations were of a nature that could have resulted in non-award of contract to the contractor or could expose BHEL and/ or Owner to adverse consequences, financial or otherwise.</p> <p>X. Supplier/Vendor is convicted of any offence involving corrupt business practices, antinational activities or any such offence that compromises the business ethics of BHEL, in violation of the Integrity Pact entered into with BHEL</p>	

has the potential to harm the overall business of BHEL/ Owner.

Note-Once BHEL considers that a breach of contract has occurred on the part of Supplier/Vendor, BHEL shall notify the Supplier/Vendor by way of notice in this regard. Contractor shall be given an opportunity to rectify the reasons causing the breach of contract within a period of 14 days.

In case the contractor fails to remedy the breach, as mentioned in the notice, to the satisfaction of BHEL, BHEL shall have the right to take recourse to any of the remedial actions available to it under the relevant provisions of contract.

Remedies in case of Breach of Contract.

i) Wherein the period as stipulated in the notice issued under above clause has expired and Supplier/Vendor has failed to remedy the breach, BHEL will have the right to terminate the contract on the ground of "Breach of Contract" without any further notice to contractor.

ii) Upon termination of contract, BHEL shall be entitled to recover an amount equivalent to 10% of the Contract Value for the damages on account of breach of contract committed by the Supplier/Vendor. This amount shall be recovered by way of encashing the security instruments like performance bank guarantee etc available with BHEL against the said contract. In case the value of the security instruments available is less than 10% of the contract value, the balance amount shall be recovered from other financial remedies (i.e. available bills of the Supplier/Vendor, retention amount, from the money due to the Supplier/Vendor etc. with BHEL) or the other legal remedies shall be pursued.

iii) wherever the value of security instruments like performance bank guarantee available with BHEL against the said contract is 10% of the contract value or more, such security instruments to the extent of 10% contract value will be encashed. In case no security instruments are available or the value of the security instruments available is less than 10% of the contract value, the 10% of the contract value or the balance amount, as the case may be, will be recovered in all or any of the following manners:

iv) In case the amount recovered under sub clause (a) above is not sufficient to fulfil the amount recoverable then; a demand notice to deposit the balance amount within 30 days shall be issued to Supplier/Vendor.

v) If Supplier/Vendor fails to deposit the balance amount within the period as prescribed in demand notice, following action shall be taken for recovery of the balance amount:

a) from dues available in the form of Bills payable to defaulted Supplier/Vendor against the same contract.

b) If it is not possible to recover the dues available from the same contract or dues are insufficient to meet the recoverable amount, balance amount shall be recovered from any money(s) payable to Supplier/Vendor under any contract with other Units of BHEL including recovery from security deposits or any other deposit available in the form of security instruments of any kind against Security deposit or EMD.

vi) In-case recoveries are not possible with any of the above available options, Legal action shall be initiated for recovery against defaulted supplier/Vendor.

vii) It is an agreed term of contract that this amount shall be a genuine pre-estimate of damages that BHEL would incur in completion of balance contractual obligation of the contract through any other agency and BHEL will not be required to furnish any other evidence to the Supplier/Vendor for the purpose of estimation of damages.

viii) In addition to the above, imposition of liquidated damages, debarment, termination, de-scoping, short-closure, etc., shall be applied as per provisions of

		<p>the contract.</p> <p>Note:</p> <p>1) The defaulting Supplier/Vendor shall not be eligible for participation in any of the future enquiries floated by BHEL to complete the balance work. The defaulting contractor shall mean and include:</p> <p>(a) In case defaulted Supplier/Vendor is the Sole Proprietorship Firm, any Sole Proprietorship Firm owned by same Sole Proprietor.</p> <p>(b) In case defaulted Supplier/Vendor is The Partnership Firm, any firm comprising of same partners/ some of the same partners ; or sole proprietorship firm owned by any partner(s) as a sole proprietor.</p>	
37.	<p>Suspension of Business Dealings with Suppliers / Contractors:</p>	<p>The offers of the bidders who are under suspension as also the offers of the bidders, who engage the services of the banned firms / principal / agents, shall be rejected. The list of banned firms is available on BHEL web site www.bhel.com.</p> <p>If any bidder / supplier / contractor during pre-tendering / tendering / post tendering / award / execution / post-execution stage indulges in any act, including but not limited to, mal-practices, cheating, bribery, fraud or and other misconduct or formation of cartel so as to influence the bidding process or influence the price or tampers the tendering process or acts or omits in any manner which tantamount to an offence punishable under any provision of the Indian Penal Code, 1860(Bhartiya Nyaya Samhita 2023) or any other law in force in India, or does anything which is actionable under the Guidelines for Suspension of Business dealings, action may be taken against such bidder / supplier / contractor as per extant guidelines of the company available on www.bhel.com and / or under applicable legal provisions. Guidelines for suspension of business dealings is available in the webpage: http://www.bhel.com/vender_registration/vender.php.</p>	
38.	<p>Settlement of Dispute, CONCILIATION & ARBITRATION</p>	<p>Settlement of Dispute</p> <p>If any dispute or difference of any kind whatsoever shall arise between BHEL and the Supplier/Vendor, arising out of the contract for the performance of the work whether during the progress of contract termination, abandonment or breach of the contract, it shall in the first place referred to Designated Officer / IEM for amicable resolution by the parties. Designated Officer / IEM who within 60 days after being requested shall give written notice of his decision to the contractor. Save as hereinafter provided, such decision in respect of every matter so referred shall forthwith be given effect to by the Supplier/Vendor who shall proceed with the work with all due diligence, whether he or BHEL desires to resolve the dispute as hereinafter provided or not. If after the Designated Engineer has given written notice of this decision to the party and no intention to pursue the dispute has been communicated to him by the affected party within 30 days from the receipt of such notice, the said decision shall become final and binding on the parties. In the event the Supplier/Vendor being dissatisfied with any such decision or if amicable settlement cannot be reached then all such disputed issues shall be resolved through conciliation in terms of the BHEL Conciliation Scheme 2018 as per 'CONCILIATION' Clause.</p> <p>CONCILIATION:</p> <p>Any dispute, difference or controversy of whatever nature howsoever arising under or out of or in relation to this Agreement (including its interpretation) between the Parties, and so notified in writing by either Party to the other Party (the "Dispute") shall, in the first instance, be attempted to be resolved amicably in accordance with the conciliation procedure as per BHEL Conciliation Scheme 2018. The proceedings of Conciliation shall broadly be governed by Part-III of the Arbitration and Conciliation Act 1996 or any statutory modification thereof and as provided in - "Procedure for conduct of conciliation proceedings" (as available in</p>	

www.bhel.com).

Note: Ministry of Finance has issued OM reference No. 1/2/24 dated 03.06.2024 regarding "Guidelines for Arbitration and Mediation in Contracts of Domestic Public Procurement. In the said OM it has been recommended that Government departments/ Entities/agencies are to encourage mediation under the Mediation Act. 2023. The said Act has not yet been notified by the Government. Therefore, the clause "Settlement of Disputes" shall be modified accordingly as and when the Mediation Act 2023 gets notified.

ARBITRATION:

Except as provided elsewhere in this Contract, in case Parties are unable to reach amicable settlement (whether by Conciliation to be conducted as provided herein above or otherwise) in respect of any dispute or difference; arising out of the formation, breach, termination, validity or execution of the Contract; or, the respective rights and liabilities of the Parties; or, in relation to interpretation of any provision of the Contract; or, in any manner touching upon the Contract (hereinafter referred to as the 'Dispute'), then, either Party may, refer the disputes to Arbitral Institution and such dispute to be adjudicated by Sole Arbitrator appointed in accordance with the Rules of said Arbitral Institution.

A party willing to commence arbitration proceeding shall invoke Arbitration Clause by giving notice to the other party in terms of section 21 of the Arbitration & Conciliation Act, 1996 (hereinafter referred to as the 'Notice') before referring the matter to arbitral institution. The Notice shall be addressed to the Head of the Region, Power Sector/ Unit, BHEL, executing the Contract and shall contain the particulars of all claims to be referred to arbitration with sufficient detail and shall also indicate the monetary amount of such claim including interest, if any.

After expiry of 30 days from the date of receipt of aforesaid notice, the party invoking the Arbitration shall submit that dispute to the Arbitral Institutions (shall be identified by the contract issuing agency) and that dispute shall be adjudicated in accordance with their respective Arbitration Rules. The matter shall be adjudicated by a Sole Arbitrator who shall necessarily be a Retd Judge having considerable experience in commercial matters to be appointed/nominated by the respective institution. The cost/expenses pertaining to the said Arbitration shall also be governed in accordance with the Rules of the respective Arbitral Institution. The decision of the party invoking the Arbitration for reference of dispute to a specific Arbitral institution for adjudication of that dispute shall be final and binding on both the parties and shall not be subject to any change thereafter. The institution once selected at the time of invocation of dispute shall remain unchanged.

The fee and expenses shall be borne by the parties as per the Arbitral Institutional rules.

The Arbitration proceedings shall be in English language and the seat and venue of Arbitration shall be at the court(s) of Haridwar.

Subject to the above, the provisions of Arbitration & Conciliation Act 1996 and any amendment thereof shall be applicable. All matters relating to this Contract and arising out of invocation of Arbitration clause are subject to the exclusive jurisdiction of the Court(s) situated at Haridwar , shall have exclusive jurisdiction.

Notwithstanding any reference to the Designated Engineer or Conciliation or Arbitration herein, a. the parties shall continue to perform their respective obligations under the Contract unless they otherwise agree. Settlement of Dispute

		<p>clause cannot be invoked by the Contractor, if the Contract has been mutually closed or 'No Demand Certificate' has been furnished by the Contractor or any Settlement Agreement has been signed between the Employer and the Contractor.</p> <p>It is agreed that Mechanism of resolution of disputes through arbitration shall be available only in the cases where the value of the dispute is less than Rs. 10 Crores. In case the disputed amount Claim, Counter claim including interest is Rs. 10 crores and above, the parties shall be within their rights to take recourse to remedies other than Arbitration, as may be available to them under the applicable laws after prior intimation to the other party. Subject to the aforesaid conditions, provisions of the Arbitration and Conciliation Act, 1996 and any statutory modifications or re-enactment thereof as amended from time to time, shall apply to the arbitration proceedings under this clause.</p> <p>In case, multiple arbitrations are invoked (whether sub-judice or arbitral award passed) by any party to under this contract, then the cumulative value of claims (including interest claimed or awarded) in all such arbitrations shall be taken in account while arriving at the total claim in dispute for the subject contract for the purpose of clause mentioned above. Disputes having cumulative value of less than 10 crores shall be resolved through arbitration and any additional dispute shall be adjudicated by the court of competent jurisdiction.</p>	
39.	<p>CONFLICT OF INTEREST AMONG BIDDERS/ AGENTS</p>	<p>A bidder shall not have conflict of interest with other bidders. Such conflict of interest can lead to anti-competitive practices to the detriment of Procuring Entity's interests. The bidder found to have a conflict of interest shall be disqualified. A bidder may be considered to have a conflict of interest with one or more parties in this bidding process, if:</p> <p>a) they have controlling partner (s) in common; or</p> <p>b) they receive or have received any direct or indirect subsidy/ financial stake from any of them; or</p> <p>c) they have the same legal representative/agent for purposes of this bid; or</p> <p>d) they have relationship with each other, directly or through common third parties, that puts them in a position to have access to information about or influence on the bid of another Bidder, or</p> <p>e) Bidder participates in more than one bid in this bidding process. Participation by a Bidder in more than one Bid will result in the disqualification of all bids in which the parties are involved. However, this does not limit the inclusion of the components/ sub-assembly/ Assemblies from one bidding manufacturer in more than one bid; or</p> <p>f) In cases of agents quoting in offshore procurements, on behalf of their principal manufacturers, one agent cannot represent two manufacturers or quote on their behalf in a particular tender enquiry. One manufacturer can also authorise only one agent/dealer. There can be only one bid from the following:</p> <ol style="list-style-type: none"> 1. The principal manufacturer directly or through one Indian agent on his behalf; and 2. Indian/foreign agent on behalf of only one principal, - <p>or</p> <p>g) A Bidder or any of its affiliates participated as a consultant in the preparation of the design or technical specifications of the contract that is the subject of the Bid, or</p> <p>h) In case of a holding company having more than one independently manufacturing units, or more than one unit having common business ownership/management, only one unit should quote. Similar restrictions would apply to closely related sister companies. Bidders must proactively declare such sister/ common business/ management units in same/ similar line of business. "</p> <p>The Bidder declares that they have read and understood the above aspects, and the bidder confirms that such conflict of interest does not exist and undertakes that they will not enter into any illegal or undisclosed agreement or understanding, whether formal or informal with other Bidder(s), in this regard. This applies in particular to prices, specifications, certifications, subsidiary contracts, submission or non-</p>	

		<p>submission of bids or any other actions to restrict competitiveness or to introduce cartelization in the bidding process. In case, the Bidder is found having indulged in above activities, the same will be considered as a violation of the tender conditions, and suitable action shall be taken by BHEL as per extant policies/ guidelines.</p>													
40.	MICRO AND SMALL ENTERPRISES (MSE):	<p>Any Bidder falling under MSE category shall furnish the following details & submit documentary evidence/ Govt. Certificate etc. in support of the same along with their techno-commercial offer.</p> <table border="1"> <thead> <tr> <th>Type under MSE</th> <th>SC/ST owned</th> <th>Women owned</th> <th>Others (excluding SC/ ST & Women Owned)</th> </tr> </thead> <tbody> <tr> <td>Micro</td> <td></td> <td></td> <td></td> </tr> <tr> <td>Small</td> <td></td> <td></td> <td></td> </tr> </tbody> </table> <p>Note: If the bidder does not furnish the above, offer shall be processed construing that the bidder is not falling under MSE category.</p> <p>a) MSE suppliers can avail the intended benefits in respect of the procurements related to the Goods and Services only (Definition of Goods and Services as enumerated by Govt. of India vide Office Memorandum F. No. 21(8)/2011-MA dtd. 09/11/2016 office of AS & DC, MSME) only if they submit along with the offer, attested copies of either Udyam Registration. Date to be reckoned for determining the deemed validity will be the last date of Technical Bid submission. Non-submission of supporting document in GeM portal will lead to consideration of their bids at par with other bidders. No benefits shall be applicable for this enquiry if the above required documents are not uploaded at the time of bid submission. Documents submitted by the bidder shall be verified by BHEL for rendering the applicable benefits.</p>	Type under MSE	SC/ST owned	Women owned	Others (excluding SC/ ST & Women Owned)	Micro				Small				
Type under MSE	SC/ST owned	Women owned	Others (excluding SC/ ST & Women Owned)												
Micro															
Small															
41.	JURISDICTION:	<p>This contract shall be governed by the Law for the time being in force in the Republic of India. Subject to clause(s) mentioned above of this contract, the Civil Court having original Civil Jurisdiction at Haridwar shall alone have exclusive jurisdiction in regard to all matters in respect of the Contract.</p>													
42.	Force Majeure	<p>"Force Majeure" shall mean circumstance which is: a) beyond control of either of the parties to contract, b) either of the parties could not reasonably have provided against the event before entering into the contract, c) having arisen, either of the parties could not reasonably have avoided or overcome, and d) is not substantially attributable to either of the parties And Prevents the performance of the contract, Such circumstances include but shall not be limited to: i) War, hostilities , invasion, act of foreign enemies. ii) Rebellion, terrorism, revolution, insurrection, military or usurped power, or civil war. iii) Riot, commotion or disorder by persons other than the contractor's personnel and other employees of the contractor and sub-contractors. iv) Strike or lockout not solely involving the contractor's personnel and other employees of the contractor and sub-contractors. v) Encountering munitions of war, explosive materials, ionizing radiation or contamination by radio-activity, except as may be attributable to the contractor's use of such munitions, explosives, radiation or radio- activity. vi) Natural catastrophes such as earthquake, tsunami, volcanic activity, hurricane or typhoon, flood, fire, cyclones etc. vii) Epidemic, pandemic etc.</p> <p>The following events are explicitly excluded from Force Majeure and are solely the responsibilities of the non-performing party: a) any strike, work-to-rule action, goslow or similar labour difficulty (b) late delivery of equipment or material (unless caused by Force Majeure event) and (c) economic hardship.</p>													

		<p>If either party is prevented, hindered or delayed from or in performing any of its obligations under the Contract by an event of Force Majeure, then it shall notify the other in writing of the occurrence of such event and the circumstances thereof within 15 (fifteen) days after the occurrence of such event.</p> <p>The party who has given such notice shall be excused from the performance or punctual performance of its obligations under the Contract for so long as the relevant event of Force Majeure continues and to the extent that such party's performance is prevented, hindered or delayed. The Time for Completion shall be extended by a period of time equal to period of delay caused due to such Force Majeure event.</p> <p>Delay or non-performance by either party hereto caused by the occurrence of any event of Force Majeure shall not</p> <p>i) Constitute a default or breach of the Contract. ii) Give rise to any claim for damages or additional cost expense occasioned thereby, if and to the extent that such delay or non-performance is caused by the occurrence of an event of Force Majeure.</p> <p>BHEL at its discretion may consider short closure of contract after 1 year of imposition of Force Majeure in line with extant guidelines. In any case, Supplier/Vendor cannot consider deemed short-closure after 1 year of imposition of Force Majeure</p>	
43.	Order of Precedence:	<p>In the event of any ambiguity or conflict between the Tender Documents, the order of precedence shall be in the order below:</p> <ol style="list-style-type: none"> a. Amendments/Clarifications/Corrigenda/Errata etc. issued in respect of the tender documents by BHEL. b. Buyer Added Bid Specific ATC c. GeM Bid Technical Conditions of Contract (TCC) d. GeM GTC 	

SPECIAL NOTE FOR BIDDERS:

- a. In the event of our customer order covering this tender being cancelled /placed on hold /otherwise modified, BHEL would be constrained to accordingly cancel / hold / modify the tender at any stage of execution.
- b. BHEL may negotiate the L1 rate, if not meeting our budget / estimated cost. BHEL may re-float the tender opened, if L1 price is not acceptable to BHEL even after negotiation.
- c. Any change in applicable rates of Tax or any other statutory levies (Direct / Indirect) or any new introduction of any levy by means of statute and its corresponding liability for the deliveries beyond the agreed delivery date for reasons not attributable to BHEL will be to vendors account. BHEL will not reimburse the same and any subsequent claim in this respect will be summarily rejected.
- d. BHEL reserves its right to reject an offer due to unsatisfactory past performance by the respective Vendor in the execution of any contract to any BHEL project / Unit.
- e. The offers of the bidders who are under suspension and also the offers of the bidders, who engage the services of the banned firms /principal/agents, shall be rejected. The list of banned firms is available on BHEL web site www.bhel.com.
- f. Recovery / deduction as applicable as per Direct and Indirect taxes as notified by Govt. Of India from time to time will be made and information/certificate for such deduction/recoveries shall be provided by BHEL to the vendor.
- g. If the delivery of supply as detailed above gets delayed beyond the delivery period, the Supplier/Vendor shall request for a delivery extension and BHEL at its discretion may extend the Contract. However, if any 'Delivery extension' is granted to the Supplier/Vendor for completion of supply, due to backlog attributable to the Supplier/Vendor, then it shall be without prejudice to the rights of BHEL to impose LD for the delays attributable to the Supplier/Vendor.
- h. In case BHEL increase the quantity during currency of the contract in line with quantity variation clause of GeM bid, delivery extension on pro-rata basis shall be given for supply of these additional quantity.

Following documents are an integral part of this Tender Enquiry and endorsed copies of these documents (duly signed and stamped on each page, as a token of acceptance) are to be submitted/uploaded along with offer on GeM portal against this bid.

1. Please submit replica of Price schedule (without prices) showing “quoted” in place of price along with techno-commercial bid (Part-I).
2. Please submit signed & Stamped copy (each page) of duly filled of confirmation column of “Buyers Specific Additional Terms & Conditions (ATC)” and its clause wise supporting documents where required.
3. Please submit signed & stamped copy (each page) for qualifying PQR with proper filled information and related supporting documents as mentioned in PQR.
4. Please submit certificate of Minimum local content as specified in the Make In India Certificate of the tender.

Pre-qualification requirements for "Hydraulic Power Supply Unit for Turbine Valves"

Cl. No.	Pre-qualification requirements	Vendor response
1	<p>Vendor should have the experience of Design, Manufacturing, Testing & Supply of Hydraulic Power Supply Unit used for operating the Main Valves of Steam Turbine having name plate rating 200 MW or above, with technical parameters listed at point no. i to xi below. The vendor to confirm.</p> <p>i) Operating Pressure of medium: ≥ 160 bar ii) Operating medium: Fire Resistant Fluid (FRF)- HFDR Type (ISO 6743/4) iii) Main Control Fluid Pump Flow: ≥ 25 LPM iv) Main Control Fluid Pump Type: 2X100% Axial Piston Pump v) Main line filter: ≤ 10 microns vi) Cooling cum Recirculation Pump Type: 2X100% vii) Return filter: ≤ 3 microns viii) Regeneration circuit: Applicable ix) Bladder Accumulator: Applicable x) Tank Capacity: ≥ 800 liters xi) Material of Tank shall be Stainless Steel.</p> <p>In support of experience, vendor to submit details of their past supply in the experience list format as per Annexure-1 (copy enclosed).</p>	
2	Vendor to confirm that they must have previously supplied & commissioned the required instrumentation i.e. Transmitters, switches, RTDs, DPS and gauges compatible with HPSU of Main Turbine Valves for Steam Turbine applications.	
3	Vendor to confirm that they must have experience of satisfactory operation of Hydraulic Power Supply Unit for Main Turbine Valves (referred at Cl. No.-1 above) atleast for one Steam Turbine Unit having name plate rating 200MW or above, for minimum one year as on date of issuance of enquiry.	
4	<p>Vendor to furnish the following documents of supplied HPSU (complying Cl. No.-1 & 3 above) for our review.</p> <p>A. GA drawing, datasheet, schematic drawing & BOM of HPSU. B. Copy of Purchase order (P.O.). P.O. date shall not be prior to 01.01.2015. C. Certificates of satisfactory operation from Customer/End user OR Test reports of supplied HPSU and Commissioning protocols at project site.</p> <p>For vendors who have supplied HPSU (complying Cl. No.-1 & 3 above) earlier to BHEL, Haridwar may inform P.O. No. only.</p>	

Signature of authorized signatory.....

Note: -

1- Against vendor's replies, BHEL reserves the right to ask for more information/documents/clarifications. Vendor's offer shall not be considered if vendor fails to furnish the document /information /clarifications as mentioned above or vendor doesn't meet the acceptance criteria mentioned at Cl. No.-1 to 4 above.

2- A brief write up on **Hydraulic Power Supply unit for main turbine valves** is also enclosed as **Annexure 2**.

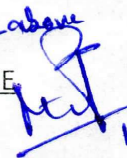
for pt. no 2 above
 Dy. Manager/CIE
 (NITIN) 
 19/06/23

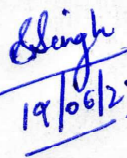
Sr. Manager/CIE
 (SHEETAL SINGH) 
 19/06/23

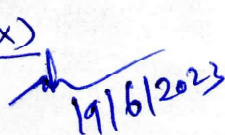
AGM(CIE&TSX)
 (Vinod Kumar) 
 19/6/2023

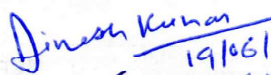
 Dy. Manager/STE-TG
 (DINESH KUMAR) 19/06/2023

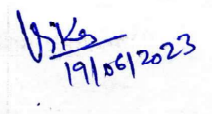
Sr. Manager/STE-TG
 (Vikas Malhotra) 
 19/06/2023

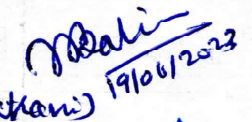
AGM/STE-TG & TM
 (Maneesh Bakshi) 
 19/06/2023

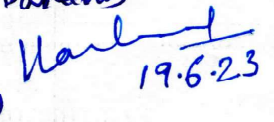
AGM/STE-HOD
 (S.K. Gupta) 
 19.6.23

Annexure – 1 (Experience list format)

Sl. No.		Parameters	Vendor response
1.	Name of the power station and it's location		*
2.	Customer name and it's address, Fax no. & Tel. No.		*
3.	Name, designation, e-mail ID & Mobile No. of the responsible person in customer's organization		*
4.	Purchase Order No. & Date		*
5.	Name plate rating in MW of individual Steam Turbine Unit	≥ 200 MW	*
6.	Date of Commissioning of system/ package		*
7.	Years of successful operation as on date of issuance of enquiry	1 years (Min.)	*
8.	HPSU Designed by		*
9.	HPSU Manufactured by		*
10.	Operating Pressure of fluid	≥160 bar	*
11.	Operating medium	Fire Resistant Fluid (FRF)- HFDR Type (ISO 6743/4)	*
12.	Main Control Fluid Pump Flow	≥ 25 LPM	*
13.	Main Control Fluid Pump Type	2X100% Axial Piston Pump	*
14.	Main line filter	≤ 10 microns	*
15.	Cooling cum Recirculation Pump Type	2X100%	*
16.	Return filter	≤ 3 microns	*
17.	Regeneration circuit	Applicable	*
18.	Bladder Accumulator	Applicable	*
19.	Tank Capacity	≥ 800 liters	*
20.	Material of Tank	Stainless Steel	*
21.	Details of HPSU: -		
a	Main Control Fluid Pump		
i	Type		
ii	make		
iii	Flow		
v	Quantity		
b	Cooling cum Recirculation pump type & make		
i	Type		
ii	Make		
iii	Flow		
v	Quantity		
c	Regeneration circuit type		
d	Main line filter type, size & flow capacity		
e	Return line filter type, size & flow capacity		
f	Regeneration circuit filter type, size & flow capacity		
g	Dehumidifier/Air ventilation filter detail		
h	Accumulator Bladder details (No., size, material & make)		
i	Cooler details (like Type, size, Material etc.)		
j	Heater details (like Type, size, Material etc.)		

Signature of authorized signatory.....

Note: -

(i)- Vendor to fill the applicable data in the format given above.

(ii)- Further the data against Sl. No.-1, 2, 3, 4, 5, 6, 7, 8, 9, 10, 11, 12, 13, 14, 15, 16, 17, 18, 19, 20 (marked as *) are to be mandatorily filled by the vendor.

Dinesh Kumar
19/06/2023
(DINESH KUMAR)

Vikas Malhotra
19/06/2023
(Vikas Malhotra)

WRITE UP ON HYDRAULIC POWER SUPPLY UNIT FOR STEAM TURBINE SETS**HYDRAULIC POWER SUPPLY UNIT:**

The main function of Hydraulic power supply unit (HPSU, MAX01) is to supply Control Fluid at 160 bar pressure with a predetermined flow rate to operate respective Electro-Hydraulic Actuators (EHAs), coupled with main turbine valves (HP Stop & Control Valve, IP Stop & Control Valve and Overload Valve (if applicable)).

HPSU (MAX01) comprises of major components i.e. control fluid pumps (MAX01 AP001/AP002/AP011/AP012), filters (MAX01 AT011/AT012/AT013/AT014/AT016), control fluid regeneration unit (MAX01 AT015), control fluid cooler (MAX01 AC010/AC020), control fluid heater (MAX01 AH001), Hydraulic pressure Accumulators (MAX01 BB011/BB012/BB013/BB014), temperature regulator (MAX01 AA151 AA152) etc. All the piping/component coming in contact with FRF are made of stainless steel.

For the redundancy and to prolong the service life of the unit, 2X100% Axial Piston Pump (MAX01 AP001/AP002) are provided for control fluid supply. In case of an on-line pump failure, operation is automatically switched over to the stand by pump. The pump function in pressure controlled mode i.e. they charge the accumulator system to 160 bar and then limit the displacement volume so that the system pressure of 160 bar is maintained constant. The electric motors and pressure relief valves (MAX01 AA061/AA062) for system pressure adjustment are mounted on the control fluid tank cover. Simplex filter (MAX01 AT011/AT012) at downstream of each control fluid pump (MAX01 AP001/AP002) have been provided having mesh size 5 micron. The filters (MAX01 AT011/AT012) are equipped with clogging indicator (MAX01 CP011/CP012) for alarm, in case of choke.

Accumulators system which is to supply the fluid quantity required for control movements of power piston, comprises a group of bladder-type accumulators with isolating valves and safety valves. Typically, 4 Nos. bladder accumulators (MAX01 BB011/BB012/BB013/BB014) are fixed at the rear side of HPSU.

The supply unit is of compact design. It comprises a tank made of stainless steel with fluid level monitoring devices (MAX01 CL501) as well as air breather & dehumidifier filter (MAX01 AT001). Moreover, a drip tray is provided at the bottom, which is at the lowest point. All electric devices are wired to a terminal strip in the terminal box (MAX01 GF001). Typically, there are 5 Nos. pressure connections (P1, P2, P3, P4 & P5) and 5 Nos. return connections (T1, T2, T3, T4 & T5) have been provided in the HPSU for further connecting the control fluid pipe to various actuators.

Separate cooling-cum-filtration circuit is provided in order to maintain the cleanliness of the system and to ensure proper cooling. Separate 2X100% capacity AC driven circulation pumps (MAX01 AP011/AP012) are applicable to supply fluid to this circuit. On the tank cover a console is mounted which contains the local pressure gauges, pressure switches and nipples for commissioning measurements. The recirculation pumps (MAX01 AP011/AP012) supply the control fluid to the cooler (MAX01 AC010/AC020) through temperature regulator (MAX01 AA151/AA152). The temperature regulator (MAX01 AA151/ AA152) is set on 45 deg C. Only in case the control fluid temperature is greater than 45 deg C, the temperature regulator allows the control fluid to be passed through the cooler (MAX01 AC010/AC020), else it supplies the control fluid directly to the tank via fine filter (MAX01 AT013/AT014) having mesh size 3 micron.

A separate regeneration circuit is provided in the HPSU with 2X100% capacity AC driven regeneration pump (MAX01 AP011/AP012). The regeneration unit pumps (MAX01 AP011/AP012) supply the control fluid from tank to control fluid regeneration unit (MAX01 AT015). In control fluid regeneration unit (MAX01 AT015), control fluid gets reconditioned and return back to tank via a filter (MAX01 AT016). The regeneration circuit is designed to purify at least 2% of the total fluid charge in the system per hour on continuous basis.

WRITE UP ON HYDRAULIC POWER SUPPLY UNIT FOR STEAM TURBINE SETS

TYPICAL SCHEMATIC DIAGRAM OF HYDRAULIC POWER SUPPLY UNIT: -

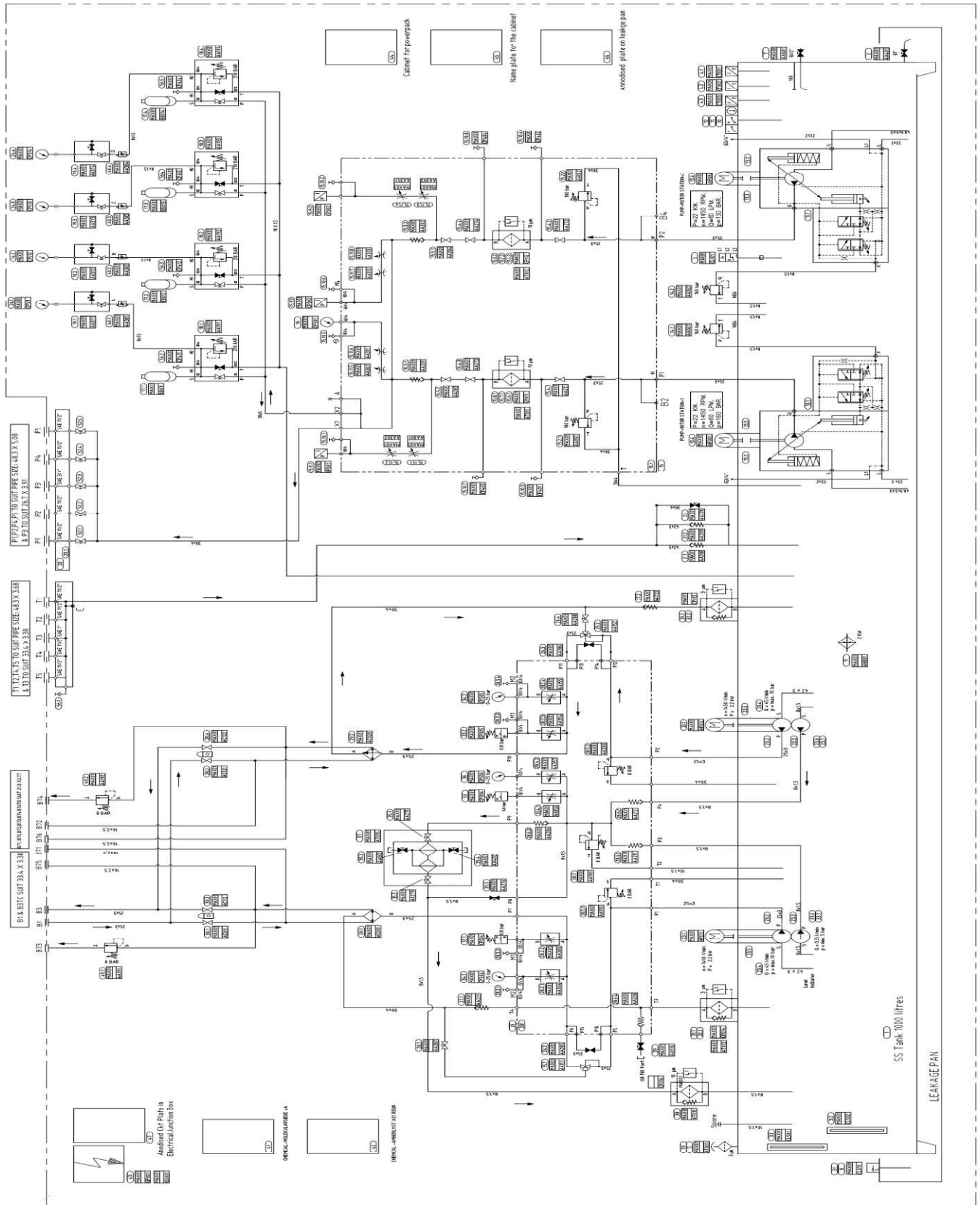

ANNEXURE – 12

**DECLARATION REGARDING MINIMUM LOCAL CONTENT IN LINE WITH
REVISED PUBLIC PROCUREMENT (PREFERENCE TO MAKE IN INDIA), ORDER 2017 DATED 04TH
JUNE, 2020 AND SUBSEQUENT ORDER(S)**

(To be typed and submitted in the Letter Head of the Entity/Firm providing certificate as applicable)

To,

(Write Name & Address of Officer of BHEL inviting the Tender)

Dear Sir,

Sub: Declaration reg. minimum local content in line with Public Procurement (Preference to Make in India), Order 2017-Revision, dated 04th June, 2020 and subsequent order(s).

Ref: 1) GeM Bid Specification No:
2) All other pertinent issues till date

We hereby certify that the items/works/services offered by..... *(specify the name of the organization here)* has a local content of _____ % and this meets the local content requirement for '**Class-I local supplier**' / '**Class II local supplier**' ** as defined in Public Procurement (Preference to Make in India), Order 2017-Revision dated 04.06.2020 issued by DPIIT and subsequent order(s).

The details of the location(s) at which the local value addition is made are as follows:

- | | |
|----------|----------|
| 1. _____ | 2. _____ |
| 3. _____ | 4. _____ |
| ... | |

Thanking you,
Yours faithfully,

**(Signature, Date & Seal of
Authorized Signatory of the Bidder)**

** - Strike out whichever is not applicable.

Note:

ANNEXURE- 3

CERTIFICATE OF NO DEVIATION

(To be Typed & submitted in the Letter Head of the Company/Firm of Bidder)

To,

(Write Name & Address of Officer of BHEL inviting the Tender)

Dear Sir,

Subject: **No Deviation Certificate**

Ref: 1) GeM Bid No:
2) All other pertinent issues till date

We hereby confirm that we have not changed/ modified/materially altered any of the tender documents as downloaded from the website/ issued by BHEL and in case of such observance at any stage, it shall be treated as null and void.

We also hereby confirm that we have neither set any Terms and Conditions and nor have we taken any deviation from the Tender conditions together with other references applicable for the above referred GeM Bid.

We further confirm our unqualified acceptance to all Terms and Conditions, unqualified compliance to Tender Conditions.

We confirm to have submitted offer in accordance with tender instructions and as per aforesaid references.

Thanking you,

Yours faithfully,

(Signature, date & seal of authorized representative of the bidder)

Date:
Place:

Framework Confidentiality Agreement cum Undertaking

This Agreement made on this the _____ day of (month) _____ 20____ (“Effective Date”) by and between
M/s BHARAT HEAVY ELECTRICALS LIMITED, having registered office at “BHEL House”, Siri Fort, New Delhi – 110049 (India), acting through its _____ Unit (hereinafter may be referred to as “BHEL” or “the Company”).

And

M/s _____ (address) _____
represented by authorized representative Sri _____ (herein after referred to as the “Supplier”).

The Supplier and the Company may, unless the context otherwise requires, hereinafter be collectively referred to as “Parties” or singly as the “Party”.

RECITALS

Whereas, BHEL is engaged in the design, engineering, manufacturing, construction, testing, commissioning and servicing of a wide range of products, systems and services for the core sectors of the economy, viz. Power, Transmission, Industry, Transportation, Renewable energy, Oil & Gas and Defence and providing associated services to varied customers in relation to which BHEL/its affiliates own valuable information of a secret and confidential nature.

Whereas the Company may, in connection with Contract(s) (as defined hereunder) placed or to be placed upon the Supplier, or otherwise, from time to time, make available, Technical Information as is defined hereunder.

And Whereas BHEL is willing to provide such Technical Information to the Supplier from time to time and the Supplier understands and acknowledges that such Technical Information is valuable for the Company and as such is willing to protect confidentiality of such information, subject to the terms and conditions set out hereunder.

Now therefore, in view of the foregoing premises and in consideration of the mutual covenants and agreements hereinafter set forth, the Parties agree as under:

1. Definitions:

Unless the context so requires, in this Agreement, the following terms will bear the meaning ascribed to the said term in this clause.

- A. **“Contract”** means the Contract entered into with a Supplier and includes a Purchase Order, or a Work Order for procurement of any goods or for provision of any services.
- B. **“Effective Date”** means the date of this Agreement as mentioned in the preamble of this Agreement.

- C. **“Supplier”** includes a Contractor or a Vendor of the Company whether for supplying of goods or for providing any services under a Contract or both.
 - D. **“Technical Information”** includes Drawings, and/or Product Standards and/or Specifications and/or Corporate / Plant Specifications and/or Technological Process Sheets and/or Technical Data Sheets and/or Jigs & Fixtures and/or Pattern & Dies and/or Special Gauges and/or Tools etc. belonging to or wherein the Company has acquired from a third party a right of user and includes any improvement thereto from time to time whether carried out by the Company or by the Supplier.
 - E. **“Intended Purpose”** means the purpose for which the Technical Information is provided to the Supplier under or in connection with a Contract.
 - F. **“Improvement”** includes any modification made to, or adaptation of, the Technical Information which enhances or is calculated to enhance the performance (whether in terms of effectiveness or in terms of efficiency or both) of the product and/or the service to be provided by the Supplier under a Contract.
2. This Agreement shall come into force/deemed to have come into force, as the case may be, on the Effective Date; or, on the first date when the Technical Information or any part thereof is provided by BHEL to the Supplier; whichever is earlier.
3. **Agreement deemed to be incorporated in each Contract:** Unless and to the extent otherwise stipulated in the Contract, the conditions of this Agreement are deemed to be incorporated in all Contracts which may be entered into between the Company and the Supplier. Further, unless otherwise stipulated, the obligations under this Agreement are and will be independent of the obligations under the Contracts and such obligations of the Supplier hereunder will remain of full effect and validity notwithstanding that the period of validity of the Contracts has expired by efflux of time stipulated therein; or, the contract has been discharged by performance or breach; or, the termination of the Contracts for any reason whatsoever.
4. **Ownership:**
- 4.1 The Company may, from time to time, make available to the Supplier, Technical Information on a non-exclusive basis by way of loan.
 - 4.2 The Supplier acknowledges and agrees that all Technical Information and copies thereof that are or may be provided by the Company to the Supplier, are and shall remain the property of BHEL or that of the concerned entity from whom BHEL has obtained the Technical Information and such Technical Information are and shall constitute trade secrets of the BHEL. Nothing in this Agreement or in any disclosures made hereunder by or on behalf of the Company shall be construed as granting upon the Supplier any patent, copyright or design or any other intellectual property rights of whatsoever description that subsists or may hereinafter exist in the Technical Information. Furthermore, nothing in this Agreement or in any disclosures made hereunder by or on behalf of the Company shall be construed as granting upon the Supplier any license or rights of use of such patent, copyright or design or any other

intellectual property rights of whatsoever description which may now or hereafter exist in the Technical Information except for use of the Technical Information strictly in accordance with this Agreement and the Contract and/or as directed in writing by the Company, solely for the Intended Purpose under the Contract.

- 4.3 Neither Party is obligated by or under this Agreement to purchase from or provide to the other Party any service or product and that any such purchase/sale of any product and/or service by one Party to the other Party will be governed by the Contract if any, that may be entered into by and between the Company and the Supplier.
- 4.4 The Supplier is/has been made well aware and acknowledges that the Technical Information being/which may be shared with it by the Company has been either generated by the Company by incurring huge investment and cost or obtained from foreign collaborators under Technical Collaboration Agreement (TCA) with stringent confidentiality conditions.
- 4.5 The Supplier agrees and undertakes to adhere to confidentiality requirements as applicable to BHEL under a TCA and also ensure that the confidentiality requirements are adhered to by all its concerned employees or sub-contractors/suppliers (where permitted to be engaged by BHEL). Any damages, losses, expenses of any description whatsoever, arising out of or in connection with a breach of the confidentiality requirements under a TCA owing to any act or omission on the part of the Supplier or its employees or sub-contractors/suppliers that is claimed by a foreign collaborator from the Company shall be wholly borne by the Supplier and it shall keep BHEL fully indemnified in this behalf. The demand by the Company shall be conclusive upon the Supplier who shall thereupon forthwith pay to the Company without demur, dispute or delay the amount as demanded without demanding any further proof thereof.
- 4.6 The Supplier agrees and undertakes that unless so decided and advised by the Company in writing all rights/title to any Improvement to the Technical Information shall vest in the Company. The Supplier undertakes and agrees to inform forthwith to the Company of any such Improvement made to the Technical Information and transfer all drawings/documents or other materials connected with such Improvement to the Company and also agrees to fully cooperate with the Company for protecting the Company's interests in such Improvement in the Technical Information including but not limited to obtaining necessary protection for the intellectual property rights in such improvement, if so desired by the Company. If a question arises whether a modification amounts to Improvement to the Technical Information, the same shall be decided by the Company and such decision shall be final and binding upon the Supplier.

5. Use and Non-Disclosure:

- 5.1 Unless otherwise stipulated by the Company, all Technical Information made available to the Supplier, by the Company shall be treated as Confidential irrespective of whether the same is marked or otherwise denoted to be Confidential or not.

- 5.2 The Supplier undertakes and agrees that the Technical Information in its possession shall be held in strict confidence and will be used strictly in accordance with this Agreement and solely for the Intended Purpose under the Contract. Use of the Technical Information for any other purpose other than Intended Purpose is prohibited.
- 5.3 In particular, the Supplier shall not use Technical Information or any Improvement in its possession for the manufacture or procurement of the Product(s) or components or parts thereof or use the Technical Information or any portion thereof or any modification or adaptation thereof in any form to provide any product and/or service to any third party, without the prior written consent of the Company.
- 5.4 The Supplier shall not disclose any of such Technical Information to any third party without the prior written consent of the Company. The Supplier agrees that without prior written consent of the Company, the Supplier shall not disclose to a third party about the existence of this Agreement, or of the fact that it is/was in possession of or has experience in the use of any Technical Information nor shall the Supplier share in any manner whatsoever, with a third party, the name or details of any Contract(s) awarded by the Company to it or performed by the Supplier or the scope of work thereof or share any document or correspondence by and between the Company and the Supplier in or in connection with this Agreement or such Contract(s). Notwithstanding what is stated elsewhere, the overall responsibility of any breach of the confidentiality provisions under this Agreement shall rest with the Supplier.
- 5.5 The Supplier undertakes and agrees not to make copies or extracts of and not to disclose to others any or all of the Technical Information in its possession, except as follows:
- (a) The Supplier may disclose the Technical Information to such of its officers and employees strictly to the extent as is necessary for such officer or employee for the Intended Purpose, provided that the Confidential Information (or copies thereof) disclosed shall be marked clearly as the confidential and proprietary information of Company and that such officers and employees shall similarly be bound by undertakings of confidence, restricted use and non-disclosure in respect of the Technical Information. The Supplier shall be responsible for any breach of such confidentiality provisions by such officers and employees.
 - (b) With the prior written consent of Company, the Supplier may disclose for the Intended Purpose such Technical Information as is provided for in such consent to such of its professional advisers: consultants, insurers and subcontractors who shall be similarly bound by undertakings of confidence, restricted use and non-disclosure in respect of such Technical Information.
 - (c) The Supplier shall not be prevented to make any disclosure required by (i) order of a court of competent jurisdiction or (ii) any competent regulatory authority or agency where such disclosure is required by law, provided that where the Supplier

intends to make such disclosure, it shall first consult Company and take all reasonable steps requested by it to minimize the extent of the Technical Information disclosed and to make such disclosure in confidence and also shall cooperate with the Company in seeking any protective order or any other remedy from proper authority in this matter.

6. Exceptions:

The obligations of the Supplier pursuant to the provisions of this agreement shall not apply to any Confidential Information that:

- a) was/is known to, or in the possession of the Supplier prior to disclosure thereof by the Company;
- b) is or becomes publicly known, otherwise than as a result of a breach of this agreement by the Supplier.
- c) is developed independently of the Disclosing Party by the Supplier in circumstances that do not amount to a breach of the provisions of this Agreement or the Contract;
- d) is received from a third party in circumstances that do not result in a breach of the provisions of this Agreement.

7. The obligation of maintaining confidentiality of the Technical Information on each occasion, shall subsist for the entire duration during which the Technical Information / equipment is in possession of the Supplier and shall thereafter subsist for a further period of --- years from the date when the complete Technical Information has been returned to the Company and if Technical Information has been returned in portions on different dates then, the period of ---- years will be reckoned from the date when the last portion of the Technical Information has been returned. Notwithstanding the expiry of the confidentiality obligation, the obligation of the Supplier under clause 5.4 shall continue to subsist for a further period of ----- years.

8. Warranties & Undertakings:

a) The Supplier undertakes to ensure the due observance of the undertakings of confidence, restricted use and non-disclosure by its persons to whom it discloses or releases copies or extracts of the Technical Information.

b) The Supplier shall keep the Technical Information or improvement made therein properly segregated and not mix up the same with any other material/documents belonging to him/it or to any other third party.

c) The Supplier further undertakes that he/it shall not hypothecate or give on lease or otherwise alienate or do away with any of the Technical Information and/or equipment of the Company, made available to him/it, and undertakes that he/it shall hold the same as a trustee, in capacity of custodian thereof and use/utilise the same solely for the purpose of executing the Contract awarded by the Company.

d)The Supplier further undertakes that he/it shall return all the equipment and/or Technical Information as far as practicable in the same condition in which the same was made available to him/it by the Company together with any Improvement thereon and the documents connected with such Improvement, to the Company forthwith upon completion of the scope

of work or Contract for which such Technical Information was provided by the Company to it or as directed by the Company together with a confirmation by way of an affidavit or in such manner as directed by the Company that it has not retained any equipment and/or Technical Information/Improvement thereof. In case any such equipment and/or Technical Information or Improvement thereof shall remain in his possession or is not capable of being returned, the retention and use of such Technical Information or Improvement thereto shall continue to be governed by this Agreement.

e) The Supplier undertakes to indemnify the Company for all the direct, indirect and/or consequential losses, damages, expenses whatsoever including any consequential loss of business, profits suffered by the Company owing to breach by the Supplier of its obligations under this Agreement and/or the confidentiality requirements, if any, contained in the Contract and that the Supplier hereby agrees that the decision of the Company in all such or any such matter/s shall be final and binding on the Supplier. On mere written demand of the Company, the Supplier shall forthwith and without demur or delay pay to the Company any such sum as determined by the Company as the amount of loss or damage or expense which has been suffered by the Company. The Supplier agrees that the Company shall be entitled to withhold and appropriate any amount payable to the Supplier under any Contract then existing between the Company and the Supplier, in case the Supplier fails to make payment, in terms of the written demand, within 7 days thereof. Without prejudice to the foregoing actions, in respect to any breach of this Agreement, the Company shall be entitled to take any other action against the Supplier as per applicable laws, the Contract, Company's applicable policies, guidelines rules, procedures, etc.

9. Without prejudice to any other mode of recovery as may be available to the Company for recovery of the amount determined as due as per Clause 8(e) hereinabove, the Company shall have a right to withhold, recover and appropriate the amount due towards such losses, damages, expenses, from any amount due to the Supplier in respect of any other Contract (s) placed on him/it by any department/office/Unit/Division of the said Company.

10. Arbitration & Conciliation:

a) In case amicable settlement is not reached between the Parties, in respect of any dispute
or

difference or claim or controversy arising out of the formation, breach, termination, validity or execution of the Contract(or Agreement) or the respective rights and liabilities of the parties or in relation to interpretation of any provision of the Contract or in any manner touching upon the Contract, then, either Party may, by a notice in writing to the other Party refer such dispute or difference or controversy or claim, (except as to any matters, the decision of which is specifically provided for therein) to the sole arbitration by the arbitrator appointed by Head/In-Charge of the Unit/Division/Region.

b) The Arbitrator shall pass a reasoned award and the award of the Arbitrator shall be final and binding upon the parties to the dispute.

c) Subject as aforesaid, the provisions of Arbitration and Conciliation Act 1996 (India), or other statutory modifications or re enactments thereof and the rules made thereunder and for

the time being in force shall apply to the arbitration proceedings under this clause. The seat of arbitration shall be at ----- **(Insert the name of the city/town of the concerned BHEL Unit/Division).**

d) In case of Contract with Public Sector Enterprise (PSE) or a Government Department, the following shall be applicable:

In the event of any dispute or difference relating to the interpretation and application of the provisions of the Contract, such dispute or difference shall be referred to by either party to the arbitration of one of the arbitrators in the department of public enterprises to be nominated by the Secretary to the Government of India in-charge of the Department of Public Enterprises. The Arbitration and Conciliation Act, 1996 shall not be applicable to arbitration under this clause. The award of the arbitrator shall be binding upon the parties to the dispute, provided, however, any party aggrieved by such award may make further reference for setting aside or revision of the award to the Law Secretary, Department of Legal Affairs, Ministry of Law and Justice, Government of India. Upon such reference the dispute shall be decided by the Law Secretary or the Special Secretary or Additional Secretary when so authorized by the Law Secretary, whose decision shall bind the parties hereto finally and conclusively.

e) Notwithstanding the existence or any dispute or differences and/or reference for the arbitration, the Supplier shall proceed with and continue without hindrance the performance of its obligations under this Contract with due diligence and expedition in a professional manner.

11. Governing Law & Jurisdiction:

This Agreement shall be governed by and be construed as per applicable Indian Laws in force at the relevant time.

Subject to clauses 10(a) and 10(d) hereinabove, all matters in connection with the subject agreement shall be subject to exclusive jurisdiction of Courts situated at -----**(insert the name of the place where the BHEL Unit/Division is located)**

SIGNATURE

WITNESSES

1.

Name

Address:

2.

Name:

Address: