



BHEL ref . B/4011/2026/0447/V1 for the requirement of EHA & ITS SPARES for Koradi project on GeM Portal

LIST OF ENCLOSURES

	<u>Document</u>	<u>Number of pages</u>
1.	PRE-QUALIFICATION REQUIREMENT	04
2.	A BRIEF WRITE UP OF EHA	05
3.	BUYER SPECIFIC TERMS & CONDITIONS OF TENDER	19
4.	MADE IN INDIA DECLARATION FORMAT	02
5.	FCA FORMAT	07
6.	FORMAT OF BANK GUARANTEE FOR PERFORMANCE SECURITY	03
7.	INTEGRITY PACT	05
8.	NO DEVIATION CERTIFICATE	01
9.	QP FORMAT	01
	TOTAL PAGES	47

Sachin Gupta (Sr.Engineer/PPX-BOI)

Email: gupta.sachin@bhel.in

Ph. 01334-281670

Manoj Kumar(DGM/ PPX-BOI)

Email: manojy@bhel.in

Ph. 01334- 285773

Pre-qualification requirements (PQR) for "Electro-hydraulic actuators of Main Turbine valves"

Clause No.	Pre-Qualification Requirements	Vendor Response
1	The vendor should have the experience of Design, Manufacturing, Testing, Supply & Commissioning of Electro-hydraulic actuators of Main Turbine valves for Steam Turbine rating 660 MW (or above) with parameters listed below (a to d): a- Quick closing time (Trip time) of Electro-hydraulic actuators should be 170 Mili second (or less); b- Operational philosophy of Electro-hydraulic actuators should be "Oil pressure to open & Spring force to close"; c- Electro-hydraulic actuators should be operated from an independent Hydraulic power supply unit; d- Working pressure of control fluid in-side Actuator should be 160 bar (or above). However, working pressure 160 bar is also acceptable for Steam turbine rating of 250 MW (or above). The vendor to confirm.	
2	The vendor to submit experience details of supplied Electro-hydraulic actuators as per Annexure-A (copy enclosed) complying the requirements mentioned at Sl. No. 1 above, for at least one power station having minimum one year of satisfactory running experience as on date of issuance of enquiry.	
3	The vendor should have the in-house testing facilities for testing (like stroke test, timing test, hydraulic test etc.) of Electro-hydraulic actuators. The vendor to confirm. Also furnish the supporting documents.	
4	The vendor to furnish the following documents for our review for executed purchase orders referred against sl. no. 2 above: a- Copy of Unpriced Purchase Order; b- Test reports of the Electro-hydraulic Actuators; c- Material acceptance certificate/ dispatch documents of Electro-hydraulic Actuators; d- Customer/End user certificate of minimum one year of satisfactory operation of Electro-hydraulic Actuators. The date of issue of certificate shall not be older than 15 years from the date of issuance of enquiry. For vendors who have supplied Electro-hydraulic actuators of Main Turbine valves (as per Sl. No.-1 above) earlier to BHEL, Haridwar may inform Purchase Order number only.	
5	A Joint Venture/ Subsidiary Company/ Sister Company/ Collaborator Company formed for manufacturing and supply of Electro-hydraulic actuators in India can also be considered, provided that it has a valid collaboration or licensing agreement with a qualified original equipment manufacturer (OEM) who meets the qualification requirements stipulated at Sl. No. 1, 2 & 3 above. Valid collaboration/licensing agreement should be in existence before the date of issuance of enquiry & shall be maintained for a lock-in period of Seven (07) years from the date of issuance of enquiry. Vendor to submit supporting documents in this regard.	
6	In case the qualification is sought as per clause 5: a- The details of vendor shall be submitted as per Annexure-B & details of its collaborator (i.e. manufacturer of proven equipment as per clause-1, 2 & 3) shall be submitted as per Annexure-A. b- The vendor should have established manufacturing and testing facilities at its works as per Collaborator/licenser's design, manufacturing and quality control system for such equipment duly certified by the Collaborator/licensor as on date of issuance of enquiry. Evidence/Confirmation to be furnished from OEM. c- Collaborator/Licenser shall provide all design documents, manufacturing drawings and must provide technical and quality surveillance assistance and supervision during manufacturing, erection, testing & commissioning of equipment. Evidence/Confirmation to be furnished from OEM. Also Collaborator/licensor shall provide the required technical and service support during operation of Actuators, if needed. d- Collaborator/Licenser shall provide guarantee towards quality and workmanship of the product manufactured at India. Evidence/Confirmation to be furnished from OEM. e- Vendor to confirm to provide all design documents authored/vetted by its collaborator (who meets requirements mentioned at point 1, 2 & 3 above) for review/approval by BHEL after placement of purchase order; f- Vendor to confirm that all major Casting, Forgings, Bought-out items such as Solenoid valves, Servo valves etc. shall be procured from its Collaborator approved sub-vendor only. Collaborator approved sub vendor list is to be furnished to BHEL along with the offer.	

Signature of authorized signatory.....

Note:-

- Against vendor's replies, BHEL reserves the right to ask for more information/documents/clarifications. Vendor's offer shall not be considered if vendor fails to furnish the document/information/clarifications as mentioned above or vendor doesn't meet the above acceptance criteria.
- A brief Write up on Electro-hydraulic actuators for main turbine valves is also enclosed.

Sr. Mgr. (STE-TG) Lakhmi
25/01/26DGM (STE-TG) BSB
25/01/2026AGM (STE-TG, TS & TF) विश्व
25/01/2026AGM (STE-HOD) M. Zafar
27/01/2024

Annexure – A

Sl. No.		BHEL PQR requirement	Vendor's response
1.	Name of the station and its Location		*
2.	Client name and its address, Fax no. & Tel. No.		*
3.	Name, designation, e-mail id & Mobile no. of the responsible person in client's organization		*
4.	Purchase order No. & Date		*
5.	Name plate rating in MW of individual Steam turbine unit		*
6.	Actual date of supply		*
7.	Date of Commissioning of Electro-hydraulic actuators		*
8.	Years of successful operation as on date of issuance of enquiry	1 years (Min.)	*
9.	Brief Scope of work		
10.	Designed by		*
11.	Manufactured by		*
12.	Working fluid (Mineral oil/Fire resistant fluid)		*
13.	Normal working pressure of control fluid		*
14.	Operation philosophy	Oil pressure to open & Spring force to close	*
15.	Spring type		
16.	EHA's for turbine valves :		
16.1	HP Stop valve actuator:		
a)	Actuator piston diameter		
b)	Piston rod diameter		
c)	Damping stroke		
d)	Total actuator stroke, including over stroke		
e)	Actuator opening time		
f)	Actuator closing time (Trip time)	≤ 170 ±10% ms	*
g)	Spring size & no. of springs		
h)	Model no & make of EHA open/close (Pilot) valve		
i)	Model no. & make of EHA solenoid trip valve		
16.2	HP control valve actuator:		
a)	Actuator piston diameter		
b)	Piston rod diameter		
c)	Damping stroke		
d)	Total actuator stroke, including over stroke		
e)	Actuator opening time		
f)	Actuator closing time (Trip time)	≤ 170 ± 10% ms	*
g)	Spring size & no. of springs		
h)	Model no. & make of EHA Servo valve		
i)	Make and model no. of EHA solenoid trip valves		
16.3	IP stop valve actuator:		
a)	Actuator piston diameter		
b)	Piston rod diameter		
c)	Damping stroke		
d)	Total actuator stroke, including over stroke		
e)	Actuator opening time		
f)	Actuator closing time (Trip time)	≤ 170 ±10% ms	*
g)	Spring size & no. of springs		
h)	Model no & make of EHA open/close (Pilot) valve		
i)	Model no. & make of EHA solenoid trip valve		

Lakshmi

16.4	IP control valve actuator:		
a)	Actuator piston diameter		
b)	Piston rod diameter		
c)	Damping stroke		
d)	Total actuator stroke, including over stroke		
e)	Actuator opening time		
f)	Actuator closing time (Trip time)	$\leq 170 \pm 10\% \text{ ms}$	*
g)	Spring size & no. of springs		
h)	Model no. & make of EHA Servo valve		
i)	Make and model no. of EHA solenoid trip valves		
16.5	Overload control valve actuator (if applicable):		
a)	Actuator piston diameter		
b)	Piston rod diameter		
c)	Damping stroke		
d)	Total actuator stroke, including over stroke		
e)	Actuator opening time		
f)	Actuator closing time (Trip time)	$\leq 170 \pm 10\% \text{ ms}$	*
g)	Spring size & no. of springs		
h)	Model no. & make of EHA Servo valve		
i)	Make and model no. of EHA solenoid trip valves		

Note:

(i)- Vendor to fill the applicable data in the format given above.

(ii)- Further the data marked as * are to be **mandatorily** filled by the vendor.

Lakshmi

Annexure-B

Detail of Indian JV /subsidiary company/ Sister Company/Collaborator Company proposed for manufacturing of Electro-hydraulic actuators as per clause no. 5 of Pre-qualification requirement			
SL. NO.	Item Description	BHEL Requirement	Applicable data
1	Name and address with telephone no. of the Indian JV /subsidiary company/ Sister Company/Collaborator Company proposed for manufacturing of Electro-hydraulic actuators .		
2	Name and address with telephone no. of the promoter of JV /subsidiary company/ Sister Company/Collaborator Company, who meets the requirement of clause 1, 2 & 3 of Pre-qualification requirement.		
3	% of the equity held by the promoter(s).		
4	Collaboration /licensing agreement lock in period	Seven (07) years from the date of issuance of enquiry	
5	M/s. (JV/subsidiary company/Sister Company/Collaborator Company) has a collaboration or valid licensing agreement with M/s..... (Promoter company) for design, Engineering, manufacturing & supply of Electro-hydraulic actuators .	The vendor to furnish valid collaboration/licensing agreement which should be in existence before the date of issuance of enquiry & shall be maintained for a lock-in period of Seven (07) years from the date of date of issuance of enquiry.	
6	The vendor to furnish commitment for lock in period as per requirement.	Confirmation to be provided by the vendor	

The vendor to submit documentary evidence in support of above requirements.

Signature of authorized signatory.....

Lokhmi

A BRIEF GENERAL WRITE UP ON ELECTRO-HYDRAULIC
ACTUATORS FOR STEAM TURBINE VALVES FOR 250/660/800 MW
RATING STEAM TURBINE SETS

Rev.	Date	Issue resp./ Modification	Office	Prepared by	Reviewed by
00	09.12.2025	First issue	STE, CIE	Lakhmi Singh (STE-TG) Nitin (CIE)	Vikas Malhotra (STE-TG) Sheetal Singh (CIE)

BHEL HARIDWAR

Transmittal, reproduction, dissemination and/or editing of this document as well as utilization of its contents and communication thereof to others without express authorization are prohibited. Offenders will be held liable for payment of damages. All rights created by patent grant or registration of a utility model or design patent are reserved.

1 INTRODUCTION:

The steam turbine output is controlled by adjusting steam mass flow rate by turbine valves. There are total 9 nos. turbine valves viz. 2 nos. HP stop valves, 2 nos. HP control valves, 2 nos. IP stop valves, 2 nos. IP control valves and 1 no. overload control valve (if applicable). These turbine valves are hydraulically actuated. In the case of a turbine trip, turbine valves interrupt the steam flow into the turbine instantly.

There is dedicated Electro-hydraulic actuator for each turbine stop and control valve. Hence total 9 nos. actuators are envisaged. All the actuators are operated with 160 bar high pressure fire resistant fluid supplied from centralized Hydraulic Power Supply Unit (HPSU).

Electro-hydraulic actuators mainly consists of Hydraulic pistons, Disc spring, Servo valves, Pilot valve, Trip solenoid valve, Cartridge valve, Check valves, Filter etc. Servo valve/Pilot valve transmit the electrical input signal of the turbine controller output into a hydraulic signal and amplify it, guide the control fluid flow to the hydraulic actuators so that the required steam flow rate can be regulated/stopped. Cartridge valves mounted on the control blocks of actuators assemblies takes care that hydraulic actuators can close the steam valves within a very short time. A typical cross section drg. of actuator is shown below.

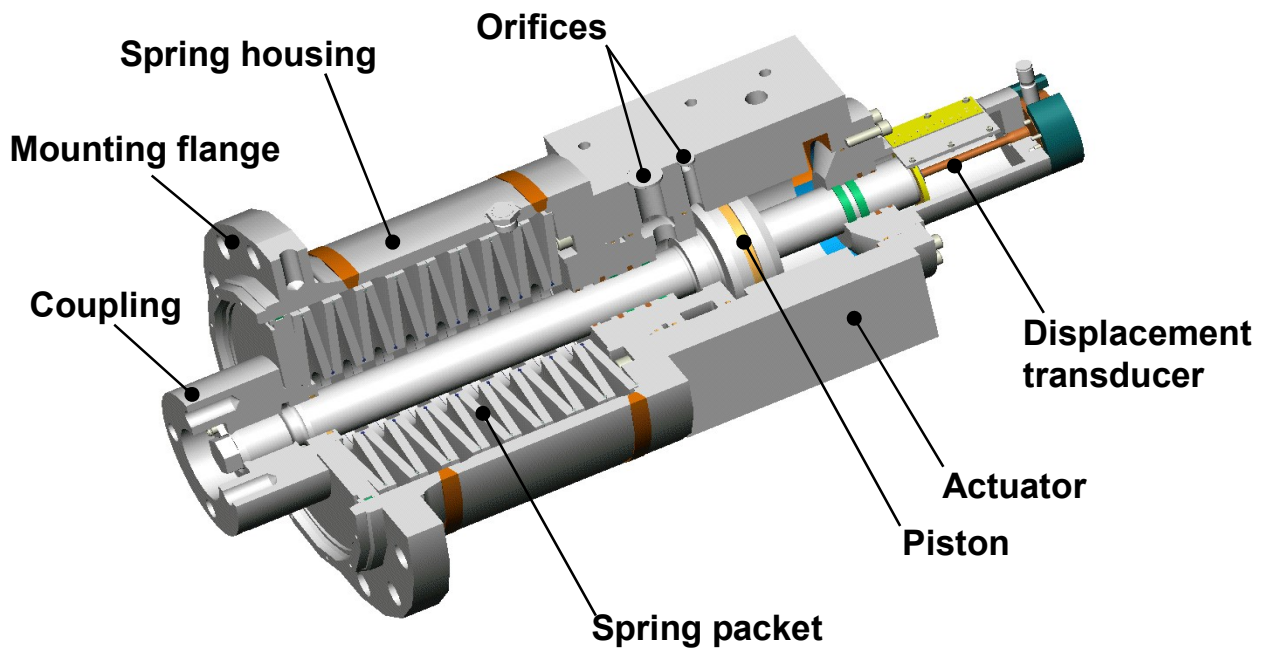

2 STOP Valve Actuator:

The stop valve actuator is an Electro-Hydraulic Actuator with control fluid supply from HPSU. The actuator comprises an operating cylinder, control unit & valve position transmitter to monitor the opening and closing of the actuator/valve. Turbine stop valve is coupled with control piston of power cylinder. The control piston which is pressure loaded in opening direction and pressure relieved on the opposite side, moves in power cylinder. The closing force is supplied to the control piston by a cup – spring stack housed inside the actuator. The actuator is connected to the HPSU through control fluid supply and return lines. A filter along with D .P. gauge is fitted in pressure line (upstream side) to prevent ingress of contamination from the pipe lines. A terminal box is also provided for wiring purpose. The control unit is mounted on the power cylinder and comprises of the Pilot valve, Trip solenoid valves, cartridge valves, check valves and orifices. All these control elements are connected via a control plate to the power cylinder through internal fluid ducts. Stop valve actuator is on/off type actuator and shall be either 0% or 100% position as per controller command. Position Transmitters / Limit Switches for Open and Close position of the valve are provided in each actuator. Typical scheme for stop valve actuator is shown below.

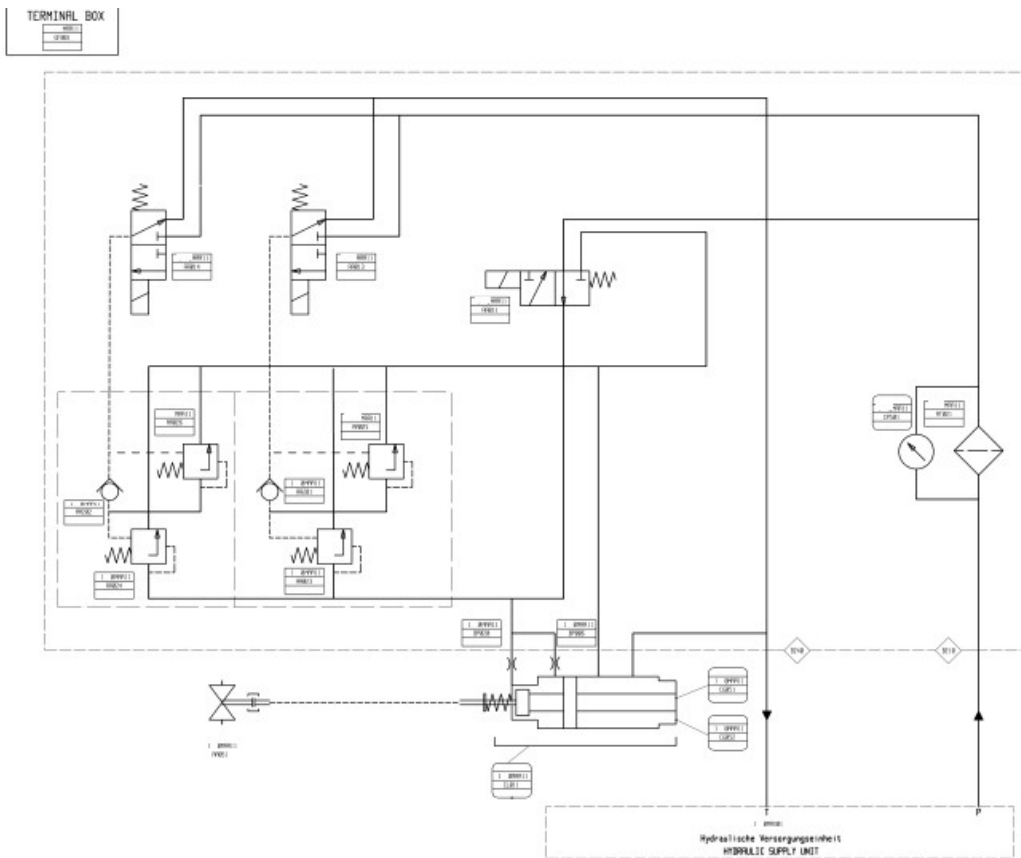

3 CONTROL Valve Actuator:

The control valve actuator is an Electro-Hydraulic Actuator with control fluid supply from HPSU. The actuator comprises an operating cylinder, control unit and valve position transmitters. Turbine control valve is coupled with the control piston of power cylinder. The control piston which is pressure loaded in opening direction and pressure relieved on the opposite side, moves in power cylinder. The closing force is supplied to the control piston by a cup – spring stack housed inside the actuator. The actuator is connected to the HPSU through control fluid supply and return lines. A filter along with D.P. gauge is fitted in pressure line (upstream side) to prevent ingress of contamination from the pipe lines. A terminal box is also provided for wiring purpose. The control unit comprises of servo valve, trip solenoid valves, cartridge valves, check valves and orifices. In addition a filter along with D.P. gauge is also fitted to the pilot control of servo-valve. All these control elements are connected via a control plate to the power cylinder through internal fluid ducts. Control valve actuator is regulating type actuator and shall be as per position given from controller command. Position Transmitters / Limit Switches for Open and Close position of the valve are provided in each actuator. Typical scheme for control valve actuator is shown below.

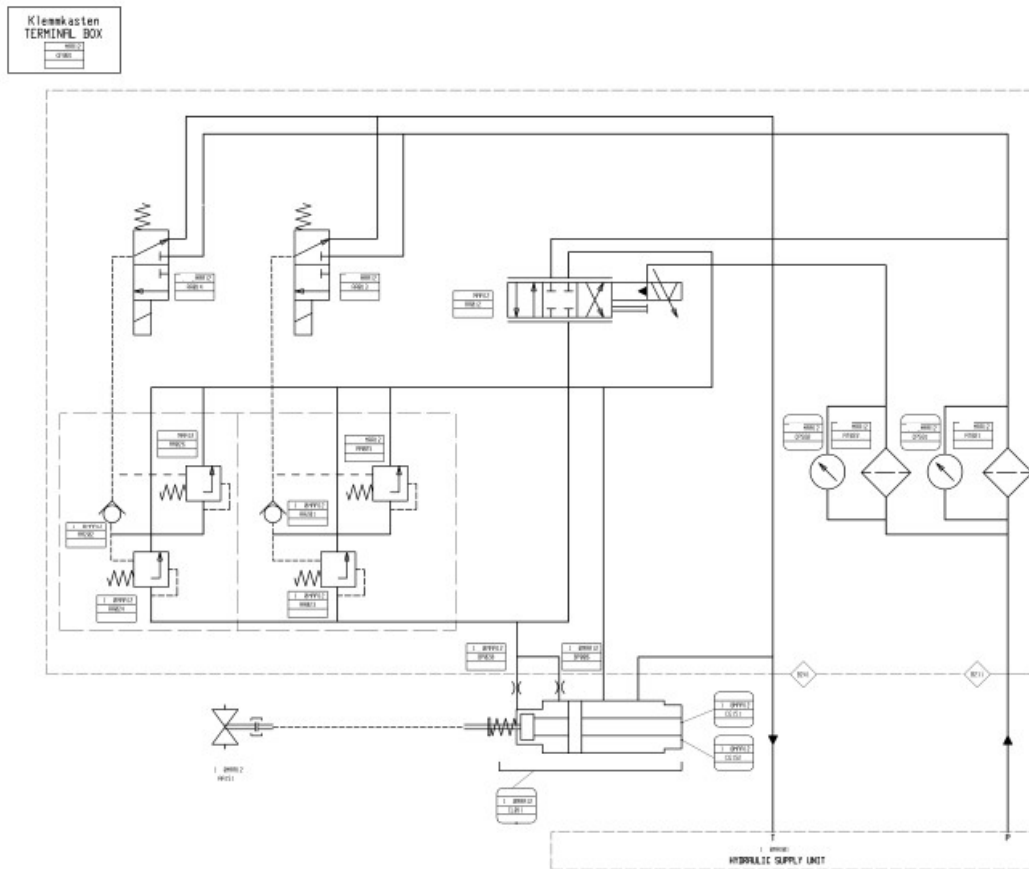

4 Scope of supply per TG set:

Sl. No.	Item description	Quantity per TG set
4.1	STOP VALVE ACTUATORS WITH COMPLETE CONTROL BLOCKS FOR HP STOP VALVES (HORIZONTALLY MOUNTED VALVE)	2 NOS. (ARRANGEMENTS WILL IN MIRROR IMAGE)
4.2	CONTROL VALVE ACTUATORS WITH COMPLETE CONTROL BLOCKS FOR HP CONTROL VALVES (HORIZONTALLY MOUNTED VALVE)	2 NOS. (ARRANGEMENTS WILL IN MIRROR IMAGE)
4.3	STOP VALVE ACTUATORS WITH COMPLETE CONTROL BLOCKS FOR IP STOP VALVES (VERTICALLY MOUNTED VALVE)	2 NOS. (ARRANGEMENTS WILL IN MIRROR IMAGE)
4.4	CONTROL VALVE ACTUATORS WITH COMPLETE CONTROL BLOCKS FOR IP CONTROL VALVES (HORIZONTALLY MOUNTED VALVE)	2 NOS. (ARRANGEMENTS WILL IN MIRROR IMAGE)
4.5	CONTROL VALVE ACTUATOR WITH COMPLETE CONTROL BLOCK FOR OVERLOAD CONTROL VALVE (HORIZONTALLY SUSPENDED VALVE), IF APPLICABLE	1 No.
4.6	SPECIAL TOOLS AND TACKLES FOR ASSLY & DIS-ASSLY. FOR ACTUATORS	1 SET
4.7	COMMISSIONING SPARES	1 SET
4.8	TRAINING & SUPERVISION DURING ERECTION & COMMISSIONING AT SITE:	REQUIRED FOR EACH SET

BUYERS SPECIFIC ADDITIONAL TERMS & CONDITIONS
ITEM NAME: ELECTRO HYDRAULIC ACTUATOR OF TURBINE VALVES WITH ITS SPARES
PROJECT: KORADI

1. SCOPE OF ENQUIRY:

E-bids on GeM portal are invited from bidders for the supply of Electro Hydraulic Actuator of Turbine Valves with its spares for Koradi project as per requirement mentioned below:

ITEM-NO	MATERIAL CODE & ITEM DESCRIPTION	QTY.	UNIT	PROJECT	DATE FOR SUPPLY COMPLETION
1	W90311400132 DRG: 11140056550 VAR00 REV: 01 ELECTRO HYDRAULIC ACTUATORS FOR TURBINE VALVES	2	SET	KORADI U-1-01 SET KORADI U-2-01 SET	KORADI U-1-07.11.2027 KORADI U-2-07.03.2028
2	W90311400361 DRG: 41140030504 VAR 00 REV: 00 COMMISSIONING SPARE PARTS FOR ELECTRO HYDRAULIC ACTUATORS OF TURBINE VALVES	1	SET	KORADI U-1-01 SET	KORADI U-1-07.11.2027
3	WS9799050081 DRG: 31140056215 REV:00 MANDATORY SPARES FOR EHA OF TURBINE VALVES	1	SET	KORADI SPARES	07.04.2029
4	ST9797119491 DRG: 418000I5053 REV:00 CIE MANDATORY SPARES FOR EHAS OF KORADI PROJECT AS PER DRAWING NO. 418000I5053 REV00	1	SET	KORADI SPARES	07.04.2029

2. Project Detail:

1. Project Name	2X660 MW KORADI U-11&12
Consignee Address	Chief Engineer / Dy. Chief Engineer (Project) Maharashtra State Power Generation Co. Ltd. Koradi Thermal Power Station Project Koradi Complex, Chhindwara Road, Distt: Nagpur, Koradi- 441111

3. EARNEST MONEY DEPOSIT (EMD):

All interested vendors must submit their e-bid along with the proof of submission of following Earnest Money Deposit (EMD) details in GeM portal along with offer EMD is applicable to all the bidders irrespective of PMD bidders/GeM provisions.

Details	Amount In INR	Type
EMD	INR 40,00,000/- (Forty lakhs only)	Refundable

3.1: Modes of deposit: The EMD may be accepted only in the following forms:

- (i) Electronic Fund Transfer credited in BHEL account (before tender opening).
- (ii) Banker's cheque/ Pay order/ Demand draft, in favour of BHEL (along with offer).
- (iii) Fixed Deposit Receipt (FDR).
- (iv) Bank Guarantee from any of the Scheduled Banks.
- (v) Insurance Surety Bonds.
- (vi) The EMD shall remain valid for a period of 45 (forty-five) days beyond the final bid validity period as asked in NIT.

For E-Payment, the RTGS details are as mentioned below:

Bank Details	SWIFT Details of bank	Contact Details of Banker
STATE BANK OF INDIA RANIPUR BRANCH, OPP: BHEL MAIN GATE, SECTOR-5, RANIPUR, HARIDWAR, UTTRAKHAND, INDIA PIN CODE: 249403	SWIFT NO : SBININBB225 CC ACCOUNT NO : 10667995458 IFSC CODE : SBIN0000586	Contact No. +91 1334 224201 +91 1334 226125 Fax: +91 1334 226512

3.2: Exemption of EMD

As per GeM GTC following are the exempted category of EMD/Bid Security.

- a. Micro and Small Enterprises (MSEs) who are holding valid Udyam Registration and are manufacturer of the offered Productor Service (Primary Product / Service - in case of bunch bid with total value wise evaluation) and give specific confirmation to this effect at the time of bid submission and claim EMD exemption and whose credentials are validated online through Udyam Registration website of Ministry of MSME and also through supporting document uploaded during bidding process and validated by the Buyer. State Government Buyers may, however, choose to exempt only MSEs from the State of Bid Inviting Authority by specifying the same in ATC of the Bid. In case no such ATC is included, eligible MSEs of all states are exempted.
- b. Start-ups as recognized by Department for Promotion of Industry and Internal Trade (DPIIT), holding valid Start-up Recognition Certificate which is to be uploaded while bidding and claiming EMD exemption and to be validated by the Buyer. Bidder to ensure that turnover for any of the financial years has not exceeded beyond limits prescribed in the certificate / Start Up scheme of DPIIT.
- c. KVIC, ACASH, WDO, Coir Board, TRIFED and Kendriya Bhandar.
- d. Sellers who have got their credentials verified through the process of Vendor Assessment by Vendor Assessment Agencies for the Primary Product / Primary Service for which Bid / RA has been invited and holding valid Vendor Assessment or Vendor Assessment Exemption Report / confirmation (Seller to upload VA report / VAE confirmation to be validated by the Buyer).
- e. Sellers / Service Provider having annual turnover of INR 500 Crore or more, at least in one of the past three completed financial year(s)
- f. Sellers / Service Providers holding valid BIS License for the Primary Product Category whose credentials are validated through BIS database and through uploaded supporting documents to be validated by the buyer.
- g. Central / State PSUs.
- h. **In addition to above GeM conditions, offers directly from the manufacturer or their authorized agents are also exempted from submission of EMD.**

3.3: Forfeiture of EMD:

- a. A bidder's EMD will be forfeited if the bidder withdraws or amends its/his tender or impairs or derogates from the tender in any respect within the period of validity of the tender or if the successful bidder fails to furnish the required performance security within the specified period mentioned in the Tender.
- b. EMD by the tenderer to be withheld in case any action on the bidder is envisaged under the provisions of extant "Guidelines on Suspension of business dealings with suppliers/ contractors" and forfeited/ released based on the action as determined under these guidelines.
- c. Bid securities of the unsuccessful bidders shall be returned to them after expiry of the final bid validity period / latest by the 30th day after the award of the contract. Since it is a two-part bidding, bid securities of unsuccessful bidders during first stage i.e. technical evaluation shall be returned within 30 days of declaration of result of first stage i.e. technical evaluation.
- d. Bid security/EMD of the successful bidder shall be returned only on conclusion of the order and receipt of a Performance Security/Performance Bank Guarantee of 10% of contract value (excluding taxes) from contractor / Supplier.
- e. EMD/PBG/PS shall not carry any interest.

4. PERFORMANCE SECURITY/PERFORMANCE BANK GUARANTEE:

Successful bidder to submit Performance Security/Performance Bank Guarantee of 5% of the contract Value (Excluding Taxes). The Performance Security/PBG shall be submitted within 30 days of notification of the award of Contract and it should remain valid for a period of 60 (sixty) days beyond the date of completion of all contractual obligations of the supplier, including warranty obligations.

PS/PBG shall be returned to the contractor without interest, after the contractor duly performs and completes the contract in all respects but not later than 60 (sixty) days of completion of all such obligations including the warranty under the contract. The Performance Security/PBG shall not carry any interest.

4.1 Modes of deposit of PS/ PBG: Performance Security/Performance Bank Guarantee shall be furnished in the following forms:

- I. Local cheques of Scheduled Banks (subject to realization)/ Pay Order/Demand Draft/ Electronic Fund Transfer in favour of BHEL.
- II. Bank Guarantee from Scheduled Banks / Public Financial Institutions as defined in the Companies Act. The Bank Guarantee format should have the approval of BHEL.
- III. Fixed Deposit Receipt issued by Scheduled Banks / Public Financial Institutions as defined in the Companies Act (FDR should be in the name of the Contractor, a/c BHEL).
- IV. Securities available from Indian Post offices such as National Savings Certificates, Kisan Vikas Patras etc. (held in the name of Contractor furnishing the security and duly endorsed/ hypothecated/ pledged, as applicable, in favour of BHEL).
- V. Insurance Surety Bond.

(Note: BHEL will not be liable or responsible in any manner for the collection of interest or renewal of the documents or in any other matter connected therewith)

4.2: Forfeiture of Performance Security/Performance Bank Guarantee:

The Performance Security/ Performance Bank Guarantee will be forfeited and credited to BHEL's account in the event of a breach of contract by the supplier.

5.BUYERS SPECIFIC ADDITIONAL TERMS & CONDITIONS IN ADDITION TO GTC

S.NO	Terms	Description	Supplier confirmation
1.	Make in India Clause	<p>For this procurement, the local content to categorize a supplier as a Class I local supplier/ Class II local Supplier/ Non local supplier and purchase preference to Class I local supplier, is as defined in Public Procurement (Preference to Make in India), Order 2017 dated 19.07.2024 issued by DPIIT. In case of subsequent orders issued by the nodal ministry, changing the definition of local content for the items of the NIT, the same shall be applicable even if issued after issue of this NIT, but before opening of Part-II bids against this NIT"</p> <p>As per Make in India Order, only Class-1 and Class-2 local supplies are eligible to bid in this tender enquiry.</p> <p>For this eligibility criteria, bidders are required to submit certificate of Minimum local content as specified in attached Make In India Declaration format.</p>	
2.	Documents Checklist:	<p>Please submit signed and stamped copy of your offer on each page along with following documents;</p> <ul style="list-style-type: none"> • Buyer Specific T&C. • Technical PQR & its supportive document. • Technical drawing & purchase specification. • Quality plan. • Certificate/self-certification for minimum local content as per PPP-MII order. • Replica of price bid schedule without prices with part-I offer. • NO deviation Certificate . <p>Please note that technical documents shall be shared against submission of FCA (FCA copy enclosed) .</p>	
3.	Compliance of GTC on GeM	General Terms and Conditions on GeM 4.0 (Version 1.29) Dtd 25.03.2026 or it's latest revision of GeM portal shall be applicable against this enquiry. Kindly confirm to compliance the same for this tender.	
4.	Pre-Qualification Requirements	The Pre-Qualification Requirements have been compiled. All the bidders should ensure submission of complete details and documents as called for in these requirements. The Offers submitted by the bidders would be scrutinized with respect to Pre-Qualification Requirements first. Techno-Commercial offer of only those bidders shall be evaluated who meet the Pre-Qualification Requirements.	
5.	Procurement from Customer Approved / Accepted Vendors only	<p>Bidders are requested to submit their credentials along with offer (Credentials should include BHEL P.O.s on vendor for the same rating or higher rating turbines, Experience of vendor with state utilities and major PSU like NTPC, End User Certificate wherever available), in order to take up with end customer for approval</p> <p>Supplier to submit following credentials for arranging Customer approval:-</p> <ul style="list-style-type: none"> • Company Profile • List of Order Executed/ on hand for Power Sector/Gov. organization of same /similar items • Copy of Major Supply Orders • Performance Certificates for Satisfactory working of System/ Equipment from end users Item. 	

		The offer of only those bidders, who meet Pre-qualification requirement (PQR), Technical requirement and approved by the End Customer, will be considered for price-bid opening or the requirement against this enquiry.									
6.	Compliance of Rule 144 (xi) of GFR 2017	Compliance of Restrictions under Rule 144 (xi) of GFR 2017 shall be as per GeM.									
7.	Bid validity/ Validity of offer	Please note that validity of the offer shall be 180 days from the date opening of Techno-Commercial bid (Part-I bid) on GeM portal. Offer of bidder's having validity less than 180 days shall liable to reject. Please confirm.									
		The required validity is considering that offer is complete & clear w.r.t. PQR and all techno-commercial conditions. Vendors need to extend their offer validity for the time taken by them in responding BHEL's comments/clarification sought during techno-commercial scrutiny of the offer. In case regret by any bidder for such validity extension, their offer shall liable to be reject. Please confirm.									
8.	Prices/Basis of Quotation	The offered prices of the items shall remain firm till the execution of the contract, kindly confirm.									
		Ensure to quote your price inclusive of Packing, forwarding, Freight & GST for Total quantity on GeM portal.									
		Transit Insurance would be arranged by BHEL. Please quote your prices accordingly.									
		The prices are to be quoted on Ex-Works with freight Pre-paid up to project destination basis. The goods must be dispatched through any Bank approved transporters having their branch at Haridwar. The names and addresses of transporters approved by IBA as well as BHEL are posted at our website www.bhelhwr.co.in. Please note that, if you dispatch the material by any BHEL un-approved transporter then you will necessarily be required to furnish the MRC (Material Receipt Certificate) from respective Project Site for processing of your invoice. No demurrage charges would be borne by BHEL.									
9.	Loading and unloading	Vendor's scope will not cover Loading & Unloading at Final destination of delivery. Unloading at final destination (i.e. BHEL site) is in BHEL 'scope. Loading and unloading at other intermediate places due to any permitted transshipment will be the responsibility of the vendor. Kindly note									
10.	Evaluation criteria	Evaluation will be done on the basis of total landed cost to BHEL, taking all material codes and service together with total cost involved for delivery up to BHEL project site (i.e.total value wise evaluation).									
11.	Evaluation Currency	The evaluation currency for this tender shall be INR.									
12.	Payment terms:	<p>For Material Portion;</p> <p>The payment shall be done after receipt of Material at BHEL respective project site, within no. of days as defined in the below table from the date of receipt of Material at site (i.e. MRC date) subject to submission of non-discrepant documents by the vendor, uploading of all documents on BHEL's SUVIDHA portal at the time of dispatch.</p> <table border="1" data-bbox="430 1791 1300 1961"> <thead> <tr> <th>Type of Bidder</th> <th>Payment Terms (Number of Days)</th> </tr> </thead> <tbody> <tr> <td>Micro & Small Enterprises (MSEs)</td> <td>45 days</td> </tr> <tr> <td>Medium Enterprises</td> <td>60 days</td> </tr> <tr> <td>Non MSME</td> <td>90 days</td> </tr> </tbody> </table>	Type of Bidder	Payment Terms (Number of Days)	Micro & Small Enterprises (MSEs)	45 days	Medium Enterprises	60 days	Non MSME	90 days	
Type of Bidder	Payment Terms (Number of Days)										
Micro & Small Enterprises (MSEs)	45 days										
Medium Enterprises	60 days										
Non MSME	90 days										

		<p>This is in supersession of 10 days' time as provided in Clause 12 of GeM GTC and also 45 days from CRAC as provided in the standard format of GeM Bid under Payment Timelines.</p> <p><u>For Supervision during E&C of equipment at project site ;</u> 100% payment against submission of Successful Commissioning or installation Certificate/Time Sheet/MOM signed by Project authorities along with Invoice direct to BHEL.</p>	
13.	GeM charges	GeM charges if any shall be either side only i.e. buyer's GeM charges shall be in buyer's account and seller's GeM charges shall be on seller's account. Please confirm.	
14.	Contract execution	Bidder's are advised to read GeM related query & clarification carefully on GeM portal. Order shall be executed through GeM.	
15.	HSN code	Kindly inform the HSN code under which supplier is proposed to sell the item, in the event of ordering.	
16.	Delivery Period	<p>Please note that BHEL's Delivery requirements are mentioned in point no 1 of above.</p> <p>Early delivery w.r.t. above lot delivery will be accepted only after written confirmation from BHEL. BHEL reserve right to reject early delivery request of bidders / suppliers.</p> <p>Delivery period indicated in GeM bid is only indicative and final delivery of tender shall be taken as mentioned above.</p> <p>Accordingly bidders to confirm the above deliveries or quote their best possible delivery in no of months / weeks from the date of placement of Purchase order, including all activities like document approval, inspection by TPI time etc.</p>	
17.	Liquidated Damages (LD) for late delivery	<p>Liquidated Damages shall be lot wise as per clause no. 15 (iii) of General terms and conditions on GeM 4.0 (Version 1.29) as under: kindly confirm.</p> <p>"If the Seller/Service Provider fails to deliver any or all of the Goods/Services within the original/re-fixed delivery period(s) specified in the contract, the Buyer will be entitled to deduct/recover the Liquidated Damages for the delay, unless covered under Force Majeure conditions aforesaid, @ 0.5% of the contract value of delayed quantity per week or part of the week of delayed period as pre-estimated damages not exceeding 10% of the contract value of delayed quantity without any controversy/dispute of any sort whatsoever".</p> <p>The date of LR would be treated as the date of delivery for penalty purposes.</p>	
18.	Technical Requirement :	<p>THE OFFER SHALL BE SENT COMPLETE IN ALL RESPECT ALONG WITH ALL THE RELEVANT DOCUMENTS AS MENTIONED AGAINST CLAUSE 9 OF BHEL DRG. NO. 1-11400-56550</p> <p>Kindly ensure completeness of the offer and furnish the check list as per Annexure-7A &7B dully filled along with the offer.</p> <p>Kindly confirm to provide 3D MODELS for supplied equipment assemblies (having all the components included) complete with all connection points/interfaces for the purpose of 3D power plant layout to be done by BHEL as per customer specification requirements. the file format of 3D model shall be informed by BHEL and the same shall be subject to customer approval.</p> <p>Kindly offer the make/model of servo valves as per BHEL specification. In case, supplier offer equivalent make/model, the same to be got approved from Siemens Germany else the equivalent offered servo valve should be proven one and should also have minimum 3 years of satisfactory running experience in steam turbine of mw rating 200 MW or above all the supporting documents along with end user certificate to be furnished by the vendor in support of satisfactory running experience.</p> <p>PI note that training program at site for 2 days shall be provided by the vendor</p>	

		regarding design/construction features, operation & maintenance of the supplied equipment (including C&I) to customer / BHEL Engineers.	
		The document no. " CIE-EHA-15" (PURCHASE SPECIFICATION FOR CIE FOR ELCTRO HYDRAULIC ACTUATORS FOR MAIN TURBINE VALVES)" is part of BHEL purchase specification and shall be complied by the vendor for Koradi project, kindly confirm.	
		EHA documents submitted by vendor for BHEL'S approval shall also be subject to customer's approval. therefore, timely submission of the complete set of EHA documents must be ensured by the vendor.	
		In case of any conflict between stipulations in various portion of the specification, most stringent stipulation would be applicable for implementation by the vendor without any cost or delivery implication to BHEL. PL confirm.	
		Deviation, if any, whether major or minor, should be brought out very clearly on deviation sheet along with the offer. In the absence of any deviation, the offer shall be deemed to be in full conformity with the specification. Hidden deviation in the offer shall not be acceptable or binding on BHEL. PL note & confirm.	
		THE NOISE LEVEL SHALL BE LESS THAN 85 DBA AT A DISTANCE 1.0 METER FROM THE SHELL OF EQUIPMENT.	
		Functional testing of actuators shall be done only with phosphate ester based FRF TRIXYLENYL PHOSPHATE (TXP) having cas no. 25155-23-1 as per BHEL specification ST22007	
		Kindly furnish item wise price (in price bid) of each item referred in BHEL drg nos for mandatory spares of EHA.	
		ST22009, wherever called in the BHEL specification drawing to be read as ST22007.	
		Kindly confirm to supply the E-LERANING package module as per the clause 8.03.05 OF ANNEXURE 6.	
		Drawings/Data sheets/documents & Quality plan as called for in the specifications/Drawings/Documents shall be submitted for approval to BHEL for BHEL/customer approval within 30 days of purchase order. Any delay in delivery on account of late submission of drawings shall be to vendors account. BHEL will arrange the approval of the drawings/data sheets/ documents within 30 days of their receipt provided those are complete in all respect. Any delay in documents submission/approval shall be on either side.	
		Documents required after order placement: Kindly confirm that in the event of ordering, you will furnish all the documents as per BHEL DRG NO 31140056501 (MDL) complying time schedule mentioned therein. for BHEL review and approval	
19.	Technical Document/ Drawing approval conditions	<p>Drawings/Data sheets/documents/QAP etc. as called for in the specifications shall be submitted by Vendor for BHEL/ Customer approval within 30 days of purchase order. BHEL shall approve these drawings/data sheets/ documents / QAP etc. within 30 days of receipt.</p> <p>Any comments on the documents shall be given by BHEL within 7 days of submission and vendor shall submit revised document / reply to comments, within 7 days of BHEL comments. However, total time for Document submission and approval shall not exceed 30 days for respective party.</p> <p>Delivery is from the date of PO, accordingly, delay in submission / revision of the documents by the vendor will automatically account for to vendor. In case of delay on account of BHEL in comments / approval of the documents, the delivery shall be re-scheduled by the no of days taken by BHEL in excess to 30 days. For delay analysis cumulative no of days (including time taken in comments), shall be considered for delivery extension.</p>	19.

20.	Recommended Spares	Please submit item wise price list of each item referred in BHEL Drawing no 2-11400-56510 (Recommended Spare Parts).These prices shall be used for our reference and future ordering (if required) and not to be considered for Evaluation.	
21.	Supervision during Erection & Commissioning and Training	<ul style="list-style-type: none"> • Kindly note that the vendor shall carry out supervision work during Erection & Commissioning of the equipment. Since there are substantial interfaces of EHA with HPSU, therefore vendor shall carry out their supervision work at site to ensure satisfactory commissioning of all EHA's along with associated HPSU. Kindly quote the lumpsum price of the same in your offer. • Kindly note that training program at site for 2 (Two) days (Once for Total Project) shall be provided by the vendor regarding design/ construction features, operation & maintenance of the supplied equipment's (Including C&I) to customer/ BHEL Engineers. <p>Please ensure that "Per Man Day" & "Per Visit" charges for Supervision during Erection & Commissioning and Training including every expense are quoted. For Koderma project – For evaluation purpose, total 14 Mondays and 03 visits charges shall be considered for commissioning and training will be considered for Koradi project.</p> <p>Payment will be made on actual number of days and visits involved in supervision of erection/ commissioning and training endorsed by project site limited to per mandays & visits considered for evaluation purpose.</p> <p>Please note that the vendor should send a checklist to BHEL prior to deputation of competent representative for Commissioning. BHEL will confirm the checklist prior to issuing Commissioning Call to the vendor. After receipt of checklist from BHEL, the vendor would send the competent representative within 15 days of confirmation of site readiness. <u>In case, any additional work is required which is beyond the scope/warranty/guarantee of the vendor, the work would be commenced only after signed agreements with site representative & the vendor.</u></p> <p>Please confirm that the charges quoted for Supervision during Erection & Commissioning and Training shall be inclusive of applicable GST .</p>	
22.	SPECIAL INSTRUCTION	<p>Please note that as per BHEL's Policy, we cannot allow Price impact for the requirement / scope of supply, which is a part of specifications of our tender enquiry. Hence please read all specification / documents thoroughly and submit your offer as per specifications of tender enquiry.</p> <p>In case of any confusion / un-clarity on any of the clause / requirement of specification, please clarify the same from BHEL before submission of offer.</p> <p>No deviation & request regarding un-clarity / contradictory conditions / ambiguity of specifications would be entertained after opening of techno-commercial offers. Further no price impact would be allowed for the requirement which is already part of the specifications of the tender enquiry, after opening of techno-commercial offers.</p> <p>Please note and confirm.</p>	
23.	Packing and	A -Kindly confirm the following packing requirements;	

	Storage	<ul style="list-style-type: none"> All the equipments/items shall be supplied in closed steel boxes/closed wooden boxes with steel cover sheet. packing boxes should be rain proof. Kindly confirm. Packaging of item should be done in such a way that it should not require any internal package inspection for at least one year. All the equipment /items shall be dispatched in seaworthy packing as per packing instruction document no. HW0232898. STORAGE & HANDLING INSTRUCTIONS of the equipment shall be furnished by the vendor separately and 2 copies of the same shall be supplied to site along with main equipment. <p>B-ADDITIONAL PACKING REQUIREMENTS FOR SPARES: 1- ALL spare items shall be packed for 5 year preservation. small spare items shall be packed & sealed in transparent plastic bags and drying agents shall be used. 2- ALL packing box shall be marked properly & numbered clearly. 3. Packing box of mandatory spares shall be painted with green color for easy identification at project sites. Mandatory spares to be written in Bold Letters on all sides of packing boxes 4.Commissioning spares need to be packed in separate boxes. Commissioning spares to be written in Bold Letters on all sides of packing boxes.</p>	
4.	Painting requirement	Kindly confirm to comply painting requirements as per BHEL check list.	
5.	Action against Bidders / vendor / supplier / contractor in case of default:	<p>In order to protect the commercial interests of BHEL, BHEL shall take action against supplies / contractors by way of suspension of business dealings, who either fail to perform or are in default without any reasonable cause, cause loss of business/ money/ reputation, indulge in malpractices, cheating, bribery, fraud or any other misconduct or formation of cartels so as to influence the bidding process or influence the price etc.</p> <p>Suspension of Business Dealings could be in the form of “Hold” or “Banning” a supplier/ contractor or a bidder and shall be as per “Guidelines for Suspension of Business Dealings with Suppliers/ Contractors” available at BHEL’s website “https://www.bhel.com/guidelines-suspension-business-dealings-supplierscontractors”</p>	
6.	MDCC clause	<p>Please note that, material shall be dispatched only after issue of Material dispatch clearance certificate (MDCC) from end customer. For issue of MDCC, vendors are required to submit all test certificates (TC) and inspection report of third party (IR) to BHEL. After review & acceptance of the quality document, BHEL will forward the same to end customer for issuance of MDCC.</p> <p>MDCC shall be issued within 7 days of receipt of complete quality documents / TCs,. In case of delay in issuance of MDCC, only delivery shall be extended by no of days taken by BHEL in excess to 7 days and all other terms and conditions of PO shall remains same & binding.</p> <p>In case any material is dispatched without MDCC and any loss is incurred by Supplier/Vendor for any reason whatsoever, BHEL shall not be responsible in any manner to compensate the supplier in this regard.</p> <p>Kindly confirm.</p>	

7.	Integrity Pact	<p>(a) IP is a tool to ensure that activities and transactions between the Company and its Bidders/ Contractors are handled in a fair, transparent and corruption free manner. Following Independent External Monitors (IEMs) on the present panel have been appointed by BHEL with the approval of CVC to oversee implementation of IP in BHEL.</p> <table border="1" data-bbox="467 247 1393 405"> <thead> <tr> <th>SI</th> <th>IEM</th> <th>Email</th> </tr> </thead> <tbody> <tr> <td>1.</td> <td>Dr. Sarat Kumar Acharya, Ex-CMD NLC</td> <td>iem1@bhel.in</td> </tr> <tr> <td>2.</td> <td>Shri R. Mukundan , (IRPS, Retd.)</td> <td>iem2@bhel.in</td> </tr> <tr> <td>3.</td> <td>Shri Madan Lal Meena, (IAS, Retd)</td> <td>iem3@bhel.in</td> </tr> </tbody> </table> <p>(b) The IP as enclosed with the tender is to be submitted (duly signed by authorized signatory) along with techno-commercial bid (Part-I, in case of two/ three-part bid). Only those bidders who have entered into such an IP with BHEL would be competent to participate in the bidding. In other words, entering into this Pact would be a preliminary qualification.</p> <p>(c) Please refer Section-8 of IP for Role and Responsibilities of IEMs. In case of any complaint arising out of the tendering process, the matter may be referred to any of the above IEM(s). All correspondence with the IEMs shall be done through email only.</p> <p>Note: <i>No routine correspondence shall be addressed to the IEM (phone/ post/ email) regarding the clarifications, time extensions or any other administrative queries, etc. on the tender issued. All such clarification/ issues shall be addressed directly to the tender issuing (procurement) department's officials whose contact details are provided below:</i></p> <table border="1" data-bbox="435 919 1406 1113"> <tbody> <tr> <td>Mr. Sachin Gupta Designation: Sr.Engineer (PPX-BOI) 4th Floor, Main Administrative Building, HEEP, BHEL, Hardwar- 249403 Uttarakhand, India Tel: +91 1334 28 1670</td> <td>Mr. Manoj Kumar Designation: DGM (PPX-BOI) 4th Floor, Main Administrative Building, HEEP, BHEL Hardwar- 249403 Uttarakhand, India Tel: +91 1334 28 5773</td> </tr> </tbody> </table>	SI	IEM	Email	1.	Dr. Sarat Kumar Acharya, Ex-CMD NLC	iem1@bhel.in	2.	Shri R. Mukundan , (IRPS, Retd.)	iem2@bhel.in	3.	Shri Madan Lal Meena, (IAS, Retd)	iem3@bhel.in	Mr. Sachin Gupta Designation: Sr.Engineer (PPX-BOI) 4 th Floor, Main Administrative Building, HEEP, BHEL, Hardwar- 249403 Uttarakhand, India Tel: +91 1334 28 1670	Mr. Manoj Kumar Designation: DGM (PPX-BOI) 4 th Floor, Main Administrative Building, HEEP, BHEL Hardwar- 249403 Uttarakhand, India Tel: +91 1334 28 5773	
SI	IEM	Email															
1.	Dr. Sarat Kumar Acharya, Ex-CMD NLC	iem1@bhel.in															
2.	Shri R. Mukundan , (IRPS, Retd.)	iem2@bhel.in															
3.	Shri Madan Lal Meena, (IAS, Retd)	iem3@bhel.in															
Mr. Sachin Gupta Designation: Sr.Engineer (PPX-BOI) 4 th Floor, Main Administrative Building, HEEP, BHEL, Hardwar- 249403 Uttarakhand, India Tel: +91 1334 28 1670	Mr. Manoj Kumar Designation: DGM (PPX-BOI) 4 th Floor, Main Administrative Building, HEEP, BHEL Hardwar- 249403 Uttarakhand, India Tel: +91 1334 28 5773																
8.	Submission of bills on BHEL SUVIDHA portal	<p>Kindly ensure to necessarily upload the despatch & invoice details <i>on BHEL SUVIDHA portal</i> at https://suvidha.bhel.in/suvidha/, prior to despatch. All documents as per PO checklist , along with additional documents (if any), must be uploaded on the portal. It is mandatory that tax invoices with a net amount (including taxes) exceeding Rs five lakhs uploaded on the portal are digitally signed using a Class 3 Digital Signature Certificate (DSC) issued by a licensed Certifying Authority. Submission of invoice document in hard copy is allowed for invoices with a net amount (including taxes) equal to and upto Rs five lakhs , in case they were not digitally signed and uploaded on the portal. Pl note that bill will be registered & processed only after uploading dispatch documents on BHEL SuVIDHA portal.</p>															
9.	Performance Security/ Performance Bank Guarantee:	<p>Successful bidder to submit Performance Security/Performance Bank Guarantee of 5% of the contract Value (Excluding Taxes). The Performance Security/PBG shall be submitted within 30 days of notification of the award of Contract and it should remain valid for a period of 60 (sixty) days beyond the date of completion of all contractual obligations of the supplier, including Guarantee/warranty obligations.</p> <p>PS/PBG shall be returned to the contractor without interest, after the contractor duly performs and completes the contract in all respects but not later than 60 (sixty) days of completion of all such obligations including the Guarantee/ Warranty under the contract. The Performance Security/PBG shall not carry any interest. Please confirm.</p>															
10.	Guarantee/Warranty clause	<p>Kindly confirm the following Guarantee/Warranty clause;</p> <ul style="list-style-type: none"> Guarantee/Warranty period shall be provided for a period of 36 months from the date of supply or 18 months from commissioning, whichever is 															

		<p>earlier. In case of any failure or trouble reported from site, the supplier should depute their representative immediately to attend the problem and replace the defective component/part if required, without any additional cost to BHEL.</p> <ul style="list-style-type: none"> The supplier to provide technical support/services or alternative solutions against any issues; reported in the equipment supplied by the vendor for up to at least 10 years from the supply date. <p>BHEL reserve the rights to reject the offers having lesser guarantee period as mentioned above.</p>	
11.	Order Acceptance :	Ink signed order acceptance shall be furnished within 15 days of order placement. In case, order acceptance is not received within 15 days of order placement, PO deemed to be accepted by you.	
12.	Beneficiary of PO	Kindly confirm on whom the PO will be placed in the event of ordering.	
13.	Additional Conditions for Assessment	<p>BHEL reserves the right to consider / Not-consider the offers based on the evaluation of documents submitted for the Pre-Qualification Criteria (PQR).</p> <p>BHEL also reserves the right to have on-site assessment of the facilities at supplier's works during the bid evaluation.</p>	
14.	O&M Manuals	<p>Kindly confirm that in the event of ordering O&M manuals will be provided in 10 nos. of Hard Copies and 03 nos portable hard disks for soft copies of O&M manual as per clause 2.4.1 of BHEL drawing no. 1-11400-56012 to BHEL HWR. 03 Nos. Hard Copies & 01 no portable hard disks of O&M Manuals shall be supplied along with the equipment at site and description of the same should be mentioned in packing list.</p> <p>Kindly note that your documents including O&M Manual shall bear the details as per cover page (Annexure-IV). Further the cover page of the O&M Manual shall be bilingual in Hindi & English Language.</p>	
15.	Quality Requirement	<p>Kindly confirm the follow quality requirement of the tender;</p> <ol style="list-style-type: none"> Kindly submit Quality plan for BHEL review & approval Inspection by third party inspection agency as per BHEL approved quality plan . For spare items, -Inspection shall be done as per BHEL QP. For items not appearing in BHEL approved QP, TC/COC shall be submitted. <p>Inspection charges will be borne by BHEL. All coordination with third party inspection agency shall be done by the supplier only.</p> <p>Inspection call to third party inspection agency may be raised directly by the supplier; however 15 days are to be provided for deputation of representative of third party inspection agency for inspection.</p>	
16.	IP Address	The bids received from same IP address shall be outrightly rejected and shall not be considered for further evaluation.	
17.	Dispatch documents	<p>Following dispatch documents to be provided immediately after directly dispatch to BHEL Project site for billing purpose:</p> <ul style="list-style-type: none"> Guarantee/Warrantee Certificates E- Invoice and commercial inv GeM invoice Original consignee copies of GR/LR/RR (Material shall be dispatched on door delivery basis without consignee copy) Packing list E-waybill part-B Original GST compliance certificate MRC/POD/Received LR/RR/GR copy (as per proof of delivery of material at 	

		BHEL Project site)	
18.	BREACH OF CONTRACT, REMEDIES AND TERMINATION:	<p>The following shall amount to breach of contract:</p> <p>I. Non-supply of material/ non-completion of work by the Supplier/Vendor within scheduled delivery/ completion period as per contract or as extended from time to time.</p> <p>II. The Supplier/Vendor fails to perform as per the activity schedule and there are sufficient reasons even before expiry of the delivery/ completion period to justify that supplies shall be inordinately delayed beyond contractual delivery/ completion period.</p> <p>III. The Supplier/Vendor delivers equipment/ material not of the contracted quality.</p> <p>IV. The Supplier/Vendor fails to replace the defective equipment/ material/ component as per guarantee clause.</p> <p>V. Withdrawal from or abandonment of the work by the Supplier/Vendor before completion as per contract.</p> <p>VI. Assignment, transfer, subletting of Contract by the Supplier/Vendor without BHEL's written permission resulting in termination of Contract or part thereof by BHEL.</p> <p>VII. Non-compliance to any contractual condition or any other default attributable to Supplier/Vendor.</p> <p>VIII. Any other reason(s) attributable to Vendor towards failure of performance of contract. In case of breach of contract, BHEL shall have the right to terminate the Purchase Order/ Contract either in whole or in part thereof without any compensation to the Supplier/Vendor.</p> <p>IX. Any of the declarations furnished by the contractor at the time of bidding and/ or entering into the contract for supply are found untruthful and such declarations were of a nature that could have resulted in non-award of contract to the contractor or could expose BHEL and/ or Owner to adverse consequences, financial or otherwise.</p> <p>X. Supplier/Vendor is convicted of any offence involving corrupt business practices, antinational activities or any such offence that compromises the business ethics of BHEL, in violation of the Integrity Pact entered into with BHEL has the potential to harm the overall business of BHEL/ Owner.</p> <p>Note-Once BHEL considers that a breach of contract has occurred on the part of Supplier/Vendor, BHEL shall notify the Supplier/Vendor by way of notice in this regard. Contractor shall be given an opportunity to rectify the reasons causing the breach of contract within a period of 14 days. In case the contractor fails to remedy the breach, as mentioned in the notice, to the satisfaction of BHEL, BHEL shall have the right to take recourse to any of the remedial actions available to it under the relevant provisions of contract.</p> <p>Remedies in case of Breach of Contract.</p> <p>i) Wherein the period as stipulated in the notice issued under above clause</p>	

has expired and Supplier/Vendor has failed to remedy the breach, BHEL will have the right to terminate the contract on the ground of "Breach of Contract" without any further notice to contractor.

ii) Upon termination of contract, BHEL shall be entitled to recover an amount equivalent to 10% of the Contract Value for the damages on account of breach of contract committed by the Supplier/Vendor. This amount shall be recovered by way of encashing the security instruments like performance bank guarantee etc available with BHEL against the said contract. In case the value of the security instruments available is less than 10% of the contract value, the balance amount shall be recovered from other financial remedies (i.e. available bills of the Supplier/Vendor, retention amount, from the money due to the Supplier/Vendor etc. with BHEL) or the other legal remedies shall be pursued.

iii) wherever the value of security instruments like performance bank guarantee available with BHEL against the said contract is 10% of the contract value or more, such security instruments to the extent of 10% contract value will be encashed. In case no security instruments are available or the value of the security instruments available is less than 10% of the contract value, the 10% of the contract value or the balance amount, as the case may be, will be recovered in all or any of the following manners:

iv) In case the amount recovered under sub clause (a) above is not sufficient to fulfil the amount recoverable then; a demand notice to deposit the balance amount within 30 days shall be issued to Supplier/Vendor.

v) If Supplier/Vendor fails to deposit the balance amount within the period as prescribed in demand notice, following action shall be taken for recovery of the balance amount:

a) from dues available in the form of Bills payable to defaulted Supplier/Vendor against the same contract.

b) If it is not possible to recover the dues available from the same contract or dues are insufficient to meet the recoverable amount, balance amount shall be recovered from any money(s) payable to Supplier/Vendor under any contract with other Units of BHEL including recovery from security deposits or any other deposit available in the form of security instruments of any kind against Security deposit or EMD.

vi) In-case recoveries are not possible with any of the above available options, Legal action shall be initiated for recovery against defaulted supplier/Vendor.

vii) It is an agreed term of contract that this amount shall be a genuine pre-estimate of damages that BHEL would incur in completion of balance contractual obligation of the contract through any other agency and BHEL will not be required to furnish any other evidence to the Supplier/Vendor for the purpose of estimation of damages.

viii) In addition to the above, imposition of liquidated damages, debarment, termination, de-scoping, short-closure, etc., shall be applied as per provisions of the contract.

Note:

1) The defaulting Supplier/Vendor shall not be eligible for participation in any of the future enquiries floated by BHEL to complete the balance work.

		<p>The defaulting contractor shall mean and include:</p> <p>(a) In case defaulted Supplier/Vendor is the Sole Proprietorship Firm, any Sole Proprietorship Firm owned by same Sole Proprietor.</p> <p>(b) In case defaulted Supplier/Vendor is The Partnership Firm, any firm comprising of same partners/ some of the same partners ; or sole proprietorship firm owned by any partner(s) as a sole proprietor.</p>	
19.	Suspension of Business Dealings with Suppliers / Contractors:	<p>The offers of the bidders who are under suspension as also the offers of the bidders, who engage the services of the banned firms / principal / agents, shall be rejected. The list of banned firms is available on BHEL web site www.bhel.com.</p> <p>If any bidder / supplier / contractor during pre-tendering / tendering / post tendering / award / execution / post-execution stage indulges in any act, including but not limited to, mal-practices, cheating, bribery, fraud or and other misconduct or formation of cartel so as to influence the bidding process or influence the price or tampers the tendering process or acts or omits in any manner which tantamount to an offence punishable under any provision of the Indian Penal Code, 1860(Bhartiya Nyaya Samhita 2023) or any other law in force in India, or does anything which is actionable under the Guidelines for Suspension of Business dealings, action may be taken against such bidder / supplier / contractor as per extant guidelines of the company available on www.bhel.com and / or under applicable legal provisions. Guidelines for suspension of business dealings is available in the webpage: http://www.bhel.com/vender_registration/vender.php.</p>	
20.	Settlement of Dispute, CONCILIATION & ARBITRATION	<p>Settlement of Dispute</p> <p>If any dispute or difference of any kind whatsoever shall arise between BHEL and the Supplier/Vendor, arising out of the contract for the performance of the work whether during the progress of contract termination, abandonment or breach of the contract, it shall in the first place referred to Designated Officer / IEM for amicable resolution by the parties. Designated Officer / IEM who within 60 days after being requested shall give written notice of his decision to the contractor. Save as hereinafter provided, such decision in respect of every matter so referred shall forthwith be given effect to by the Supplier/Vendor who shall proceed with the work with all due diligence, whether he or BHEL desires to resolve the dispute as hereinafter provided or not. If after the Designated Engineer has given written notice of this decision to the party and no intention to pursue the dispute has been communicated to him by the affected party within 30 days from the receipt of such notice, the said decision shall become final and binding on the parties. In the event the Supplier/Vendor being dissatisfied with any such decision or if amicable settlement cannot be reached then all such disputed issues shall be resolved through conciliation in terms of the BHEL Conciliation Scheme 2018 as per 'CONCILIATION' Clause.</p> <p>CONCILIATION:</p> <p>Any dispute, difference or controversy of whatever nature howsoever arising under or out of or in relation to this Agreement (including its interpretation) between the Parties, and so notified in writing by either Party to the other Party (the "Dispute") shall, in the first instance, be attempted to be resolved amicably in accordance with the conciliation procedure as per BHEL Conciliation Scheme 2018. The proceedings of Conciliation shall broadly be governed by Part-III of the Arbitration and Conciliation Act 1996 or any statutory modification thereof and as provided in - "Procedure for conduct of conciliation proceedings" (as available in www.bhel.com).</p> <p>Note: Ministry of Finance has issued OM reference No. 1/2/24 dated 03.06.2024</p>	

regarding "Guidelines for Arbitration and Mediation in Contracts of Domestic Public Procurement. In the said OM it has been recommended that Government departments/ Entities/agencies are to encourage mediation under the Mediation Act. 2023. The said Act has not yet been notified by the Government. Therefore, the clause "Settlement of Disputes" shall be modified accordingly as and when the Mediation Act 2023 gets notified.

ARBITRATION:

Except as provided elsewhere in this Contract, in case Parties are unable to reach amicable settlement (whether by Conciliation to be conducted as provided herein above or otherwise) in respect of any dispute or difference; arising out of the formation, breach, termination, validity or execution of the Contract; or, the respective rights and liabilities of the Parties; or, in relation to interpretation of any provision of the Contract; or, in any manner touching upon the Contract (hereinafter referred to as the 'Dispute'), then, either Party may, refer the disputes to Arbitral Institution and such dispute to be adjudicated by Sole Arbitrator appointed in accordance with the Rules of said Arbitral Institution.

A party willing to commence arbitration proceeding shall invoke Arbitration Clause by giving notice to the other party in terms of section 21 of the Arbitration & Conciliation Act, 1996 (hereinafter referred to as the 'Notice') before referring the matter to arbitral institution. The Notice shall be addressed to the Head of the Region, Power Sector/ Unit, BHEL, executing the Contract and shall contain the particulars of all claims to be referred to arbitration with sufficient detail and shall also indicate the monetary amount of such claim including interest, if any.

After expiry of 30 days from the date of receipt of aforesaid notice, the party invoking the Arbitration shall submit that dispute to the Arbitral Institutions (shall be identified by the contract issuing agency) and that dispute shall be adjudicated in accordance with their respective Arbitration Rules. The matter shall be adjudicated by a Sole Arbitrator who shall necessarily be a Retd Judge having considerable experience in commercial matters to be appointed/nominated by the respective institution. The cost/expenses pertaining to the said Arbitration shall also be governed in accordance with the Rules of the respective Arbitral Institution. The decision of the party invoking the Arbitration for reference of dispute to a specific Arbitral institution for adjudication of that dispute shall be final and binding on both the parties and shall not be subject to any change thereafter. The institution once selected at the time of invocation of dispute shall remain unchanged.

The fee and expenses shall be borne by the parties as per the Arbitral Institutional rules.

The Arbitration proceedings shall be in English language and the seat and venue of Arbitration shall be at the court(s) of Haridwar.

Subject to the above, the provisions of Arbitration & Conciliation Act 1996 and any amendment thereof shall be applicable. All matters relating to this Contract and arising out of invocation of Arbitration clause are subject to the exclusive jurisdiction of the Court(s) situated at Haridwar, shall have exclusive jurisdiction.

Notwithstanding any reference to the Designated Engineer or Conciliation or Arbitration herein, a. the parties shall continue to perform their respective obligations under the Contract unless they otherwise agree. Settlement of Dispute clause cannot be invoked by the Contractor, if the Contract has been

		<p>mutually closed or 'No Demand Certificate' has been furnished by the Contractor or any Settlement Agreement has been signed between the Employer and the Contractor.</p> <p>It is agreed that Mechanism of resolution of disputes through arbitration shall be available only in the cases where the value of the dispute is less than Rs. 10 Crores.</p> <p>In case the disputed amount Claim, Counter claim including interest is Rs. 10 crores and above, the parties shall be within their rights to take recourse to remedies other than Arbitration, as may be available to them under the applicable laws after prior intimation to the other party. Subject to the aforesaid conditions, provisions of the Arbitration and Conciliation Act, 1996 and any statutory modifications or re-enactment thereof as amended from time to time, shall apply to the arbitration proceedings under this clause.</p> <p>In case, multiple arbitrations are invoked (whether sub-judice or arbitral award passed) by any party to under this contract, then the cumulative value of claims (including interest claimed or awarded) in all such arbitrations shall be taken in account while arriving at the total claim in dispute for the subject contract for the purpose of clause mentioned above. Disputes having cumulative value of less than 10 crores shall be resolved through arbitration and any additional dispute shall be adjudicated by the court of competent jurisdiction.</p>	
21.	CONFLICT OF INTEREST AMONG BIDDERS/ AGENTS	<p>A bidder shall not have conflict of interest with other bidders. Such conflict of interest can lead to anti-competitive practices to the detriment of Procuring Entity's interests. The bidder found to have a conflict of interest shall be disqualified. A bidder may be considered to have a conflict of interest with one or more parties in this bidding process, if:</p> <ul style="list-style-type: none"> a) they have controlling partner (s) in common; or b) they receive or have received any direct or indirect subsidy/ financial stake from any of them; or c) they have the same legal representative/agent for purposes of this bid; or d) they have relationship with each other, directly or through common third parties, that puts them in a position to have access to information about or influence on the bid of another Bidder, or e) Bidder participates in more than one bid in this bidding process. Participation by a Bidder in more than one Bid will result in the disqualification of all bids in which the parties are involved. However, this does not limit the inclusion of the components/ sub-assembly/ Assemblies from. one bidding manufacturer in more than one bid; or f) In cases of agents quoting in offshore procurements, on behalf of their principal manufacturers, one agent cannot represent two manufacturers or quote on their behalf in a particular tender enquiry. One manufacturer can also authorise only one agent/dealer. There can be only one bid from the following: <ul style="list-style-type: none"> 1. The principal manufacturer directly or through one Indian agent on his behalf; and 2. Indian/foreign agent on behalf of only one principal, - or g) A Bidder or any of its affiliates participated as a consultant in the preparation of the design or technical specifications of the contract that is the subject of the Bid, or h) In case of a holding company having more than one independently manufacturing units, or more than one unit having common business ownership/management, only one unit should quote. Similar restrictions would apply to closely related sister companies. Bidders must proactively declare such sister/ common business/ management units in same/ similar line of business. " <p>The Bidder declares that they have read and understood the above aspects, and the bidder confirms that such conflict of interest does not exist and undertakes that they will not enter into any illegal or undisclosed agreement or understanding, whether formal or informal</p>	

		with other Bidder(s), in this regard. This applies in particular to prices, specifications, certifications, subsidiary contracts, submission or non-submission of bids or any other actions to restrict competitiveness or to introduce cartelization in the bidding process. In case, the Bidder is found having indulged in above activities, the same will be considered as a violation of the tender conditions, and suitable action shall be taken by BHEL as per extant policies/ guidelines.													
22.	MICRO AND SMALL ENTERPRISES (MSE):	<p>Any Bidder falling under MSE category shall furnish the following details & submit documentary evidence/ Govt. Certificate etc. in support of the same along with their techno-commercial offer.</p> <table border="1"> <thead> <tr> <th>Type under MSE</th> <th>SC/ST owned</th> <th>Women owned</th> <th>Others (excluding SC/ ST & Women Owned)</th> </tr> </thead> <tbody> <tr> <td>Micro</td> <td></td> <td></td> <td></td> </tr> <tr> <td>Small</td> <td></td> <td></td> <td></td> </tr> </tbody> </table> <p>Note: If the bidder does not furnish the above, offer shall be processed construing that the bidder is not falling under MSE category.</p> <p>a) MSE suppliers can avail the intended benefits in respect of the procurements related to the Goods and Services only (Definition of Goods and Services as enumerated by Govt. of India vide Office Memorandum F. No. 21(8)/2011-MA dtd. 09/11/2016 office of AS & DC, MSME) only if they submit along with the offer, attested copies of either Udyam Registration. Date to be reckoned for determining the deemed validity will be the last date of Technical Bid submission. Non-submission of supporting document in GeM portal will lead to consideration of their bids at par with other bidders. No benefits shall be applicable for this enquiry if the above required documents are not uploaded at the time of bid submission. Documents submitted by the bidder shall be verified by BHEL for rendering the applicable benefits.</p>	Type under MSE	SC/ST owned	Women owned	Others (excluding SC/ ST & Women Owned)	Micro				Small				
Type under MSE	SC/ST owned	Women owned	Others (excluding SC/ ST & Women Owned)												
Micro															
Small															
23.	JURISDICTION:	This contract shall be governed by the Law for the time being in force in the Republic of India. Subject to clause(s) mentioned above of this contract, the Civil Court having original Civil Jurisdiction at Haridwar shall alone have exclusive jurisdiction in regard to all matters in respect of the Contract.													
24.	Force Majeure	"Force Majeure" shall mean circumstance which is: a) beyond control of either of the parties to contract, b) either of the parties could not reasonably have provided against the event before entering into the contract, c) having arisen, either of the parties could not reasonably have avoided or overcome, and d) is not substantially attributable to either of the parties And Prevents the performance of the contract, Such circumstances include but shall not be limited to: i) War, hostilities , invasion, act of foreign enemies. ii) Rebellion, terrorism, revolution, insurrection, military or usurped power, or civil war. iii) Riot, commotion or disorder by persons other than the contractor's personnel and other employees of the contractor and sub-contractors. iv) Strike or lockout not solely involving the contractor's personnel and other employees of the contractor and sub-contractors. v) Encountering munitions of war, explosive materials, ionizing radiation or contamination by radio-activity, except as may be attributable to the contractor's use of such munitions, explosives, radiation or radio- activity. vi) Natural catastrophes such as earthquake, tsunami, volcanic activity, hurricane or typhoon, flood, fire, cyclones etc. vii) Epidemic, pandemic etc.													

		<p>The following events are explicitly excluded from Force Majeure and are solely the responsibilities of the non-performing party: a) any strike, work-to-rule action, goslow or similar labour difficulty (b) late delivery of equipment or material (unless caused by Force Majeure event) and (c) economic hardship.</p> <p>If either party is prevented, hindered or delayed from or in performing any of its obligations under the Contract by an event of Force Majeure, then it shall notify the other in writing of the occurrence of such event and the circumstances thereof within 15 (fifteen) days after the occurrence of such event.</p> <p>The party who has given such notice shall be excused from the performance or punctual performance of its obligations under the Contract for so long as the relevant event of Force Majeure continues and to the extent that such party's performance is prevented, hindered or delayed. The Time for Completion shall be extended by a period of time equal to period of delay caused due to such Force Majeure event.</p> <p>Delay or non-performance by either party hereto caused by the occurrence of any event of Force Majeure shall not</p> <p>i) Constitute a default or breach of the Contract. ii) Give rise to any claim for damages or additional cost expense occasioned thereby, if and to the extent that such delay or non-performance is caused by the occurrence of an event of Force Majeure.</p> <p>BHEL at its discretion may consider short closure of contract after 1 year of imposition of Force Majeure in line with extant guidelines. In any case, Supplier/Vendor cannot consider deemed short-closure after 1 year of imposition of Force Majeure</p>	
25.	Cartel Formation	<p>The Bidder declares that they will not enter into any illegal or undisclosed agreement or understanding, whether formal or informal with other Bidder(s). This applies in particular to prices, specifications, certifications, subsidiary contracts, submission or non-submission of bids or any other actions to restrict competitiveness or to introduce cartelization in the bidding process. In case, the Bidder is found having indulged in above activities, suitable action shall be taken by BHEL as per extant policies/ guidelines.</p>	
26.	Order of Precedence:	<p>In the event of any ambiguity or conflict between the Tender Documents, the order of precedence shall be in the order below:</p> <ol style="list-style-type: none"> a. Amendments/Clarifications/Corrigenda/Errata etc. issued in respect of the tender documents by BHEL. b. Buyer Added Bid Specific ATC c. GeM Bid Technical Conditions of Contract (TCC) d. GeM GTC 	

SPECIAL NOTE FOR BIDDERS:

- a. In the event of our customer order covering this tender being cancelled /placed on hold /otherwise modified, BHEL would be constrained to accordingly cancel / hold / modify the tender at any stage of execution.
- b. BHEL may negotiate the L1 rate, if not meeting our budget / estimated cost. BHEL may re-float the tender opened, if L1 price is not acceptable to BHEL even after negotiation.
- c. Any change in applicable rates of Tax or any other statutory levies (Direct / Indirect) or any new introduction of any levy by means of statute and its corresponding liability for the deliveries beyond the agreed delivery date for reasons not attributable to BHEL will be to vendors account. BHEL will not reimburse the same and any subsequent claim in this respect will be summarily rejected.

- d. BHEL reserves its right to reject an offer due to unsatisfactory past performance by the respective Vendor in the execution of any contract to any BHEL project / Unit.
- e. The offers of the bidders who are under suspension and also the offers of the bidders, who engage the services of the banned firms /principal/agents, shall be rejected. The list of banned firms is available on BHEL web site www.bhel.com.
- f. Recovery / deduction as applicable as per Direct and Indirect taxes as notified by Govt. Of India from time to time will be made and information/certificate for such deduction/recoveries shall be provided by BHEL to the vendor.
- g. If the delivery of supply as detailed above gets delayed beyond the delivery period, the Supplier/Vendor shall request for a delivery extension and BHEL at its discretion may extend the Contract. However, if any 'Delivery extension' is granted to the Supplier/Vendor for completion of supply, due to backlog attributable to the Supplier/Vendor, then it shall be without prejudice to the rights of BHEL to impose LD for the delays attributable to the Supplier/Vendor.
- h. In case BHEL increase the quantity during currency of the contract in line with quantity variation clause of GeM bid, delivery extension on pro-rata basis shall be given for supply of these additional quantity.

Following documents are an integral part of this Tender Enquiry and endorsed copies of these documents (duly signed and stamped on each page, as a token of acceptance) are to be submitted/uploaded along with offer on GeM portal against this bid.

1. Please submit replica of Price schedule (without prices) showing "quoted" in place of price along with techno-commercial bid (Part-I).
2. Please submit signed & Stamped copy (each page) of duly filled of confirmation column of "Buyers Specific Additional Terms & Conditions (ATC)" and its clause wise supporting documents where required.
3. Please submit signed & stamped copy (each page) for qualifying PQR with proper filled information and related supporting documents as mentioned in PQR.
4. Please submit signed & stamped copy (each page) of Integrity Pact.
5. Please submit certificate of Minimum local content as specified in the Make In India Certificate of the tender.

Form-1**Affidavit of Self-Certification for Compliance with Melt & Pour Requirements (Appendix-A) and/or Domestic Value Addition Requirements (Appendix-A & Appendix-B*)**

*For Appendix-B capital goods, this affidavit must accompany the statutory auditor's / cost auditor's / CA certificate, as mandated under the policy.

I, _____, Resident of _____, being the authorised signatory of M/s _____,

do hereby solemnly affirm and declare as under:

1. I have read and understood the Domestically Manufactured Iron & Steel Products (DMI&SP) Policy, 2025, issued vide Notification No. _____ dated _____. I agree to abide by all terms and conditions of the said policy and the tender in which this affidavit is submitted.

2. This affidavit pertains to the following iron & steel product(s)/capital good(s):

Name of product(s): _____

HS Code(s): _____

Appendix classification: Appendix-A / Appendix-B (select as applicable)

Procuring agency: _____

3. Melt & Pour - Applicable only for Appendix-A items with Melt & Pour condition

I hereby declare that the above product(s) satisfy the Melt & Pour in India requirement as notified in Appendix-A. Specifically:

The steel was melted and poured in India.

The first solid shape (slab/billet/ingot/other) was produced at the following location(s):

Steelmaking facility: _____ Location: _____ Heat numbers; Batch details: _____

I undertake to produce mill test certificates, heat records, and any other documentary proof to substantiate this declaration whenever required by the procuring agency.

(If not applicable, write "Not Applicable".)

4. Domestic Value Addition - Applicable for Appendix-A DVA items and Appendix-B capital goods:

I hereby declare that the Domestic Value Addition (DVA) for the product(s) is: _____%. The DVA has been computed as per DPIIT guidelines and the formula specified in the DMI&SP Policy, 2025.

4A. For Appendix-B Capital Goods (Mandatory): A certificate issued by the statutory auditor / cost auditor / chartered accountant is enclosed herewith, confirming the DVA of the capital good package in accordance with the policy.

(If Appendix-A item only, strike this clause out.)

5. I confirm that: All information furnished is true and correct. All input steel costs, imported content, and domestic content calculations have been verified. All manufacturing, purchase, and pricing records are available for examination.

If any information is found incorrect or misleading: The procuring agency may disqualify me / my firm from Government tenders as per the procuring agency norms. I agree to pay all assessment costs and penalties, including forfeiture of EMD, as per policy and tender conditions.

6. I undertake to maintain the relevant records, and make them available to any statutory authority.

7. Declaration: I do hereby declare that the statements made above are true to the best of my knowledge and belief. I understand that any misrepresentation shall attract penalties under the DMI&SP Policy, applicable laws, and tender conditions.

For and on behalf of

(Place & Date)

M/s _____
(Authorised Signatory)

[F. No. 8(2)/2023-ID-1]
ABHIJIT NARENDRA, Jt. Secy.

Framework Confidentiality Agreement cum Undertaking

This Agreement made on this the _____ day of (month) _____ 20____ (“Effective Date”) by and between
M/s BHARAT HEAVY ELECTRICALS LIMITED, having registered office at “BHEL House”, Siri Fort, New Delhi – 110049 (India), acting through its _____ Unit (hereinafter may be referred to as “BHEL” or “the Company”).

And

M/s _____ (address) _____
represented by authorized representative Sri _____ (herein after referred to as the “Supplier”).

The Supplier and the Company may, unless the context otherwise requires, hereinafter be collectively referred to as “Parties” or singly as the “Party”.

RECITALS

Whereas, BHEL is engaged in the design, engineering, manufacturing, construction, testing, commissioning and servicing of a wide range of products, systems and services for the core sectors of the economy, viz. Power, Transmission, Industry, Transportation, Renewable energy, Oil & Gas and Defence and providing associated services to varied customers in relation to which BHEL/its affiliates own valuable information of a secret and confidential nature.

Whereas the Company may, in connection with Contract(s) (as defined hereunder) placed or to be placed upon the Supplier, or otherwise, from time to time, make available, Technical Information as is defined hereunder.

And Whereas BHEL is willing to provide such Technical Information to the Supplier from time to time and the Supplier understands and acknowledges that such Technical Information is valuable for the Company and as such is willing to protect confidentiality of such information, subject to the terms and conditions set out hereunder.

Now therefore, in view of the foregoing premises and in consideration of the mutual covenants and agreements hereinafter set forth, the Parties agree as under:

1. Definitions:

Unless the context so requires, in this Agreement, the following terms will bear the meaning ascribed to the said term in this clause.

- A. **“Contract”** means the Contract entered into with a Supplier and includes a Purchase Order, or a Work Order for procurement of any goods or for provision of any services.
- B. **“Effective Date”** means the date of this Agreement as mentioned in the preamble of this Agreement.

- C. **“Supplier”** includes a Contractor or a Vendor of the Company whether for supplying of goods or for providing any services under a Contract or both.
 - D. **“Technical Information”** includes Drawings, and/or Product Standards and/or Specifications and/or Corporate / Plant Specifications and/or Technological Process Sheets and/or Technical Data Sheets and/or Jigs & Fixtures and/or Pattern & Dies and/or Special Gauges and/or Tools etc. belonging to or wherein the Company has acquired from a third party a right of user and includes any improvement thereto from time to time whether carried out by the Company or by the Supplier.
 - E. **“Intended Purpose”** means the purpose for which the Technical Information is provided to the Supplier under or in connection with a Contract.
 - F. **“Improvement”** includes any modification made to, or adaptation of, the Technical Information which enhances or is calculated to enhance the performance (whether in terms of effectiveness or in terms of efficiency or both) of the product and/or the service to be provided by the Supplier under a Contract.
2. This Agreement shall come into force/deemed to have come into force, as the case may be, on the Effective Date; or, on the first date when the Technical Information or any part thereof is provided by BHEL to the Supplier; whichever is earlier.
3. **Agreement deemed to be incorporated in each Contract:** Unless and to the extent otherwise stipulated in the Contract, the conditions of this Agreement are deemed to be incorporated in all Contracts which may be entered into between the Company and the Supplier. Further, unless otherwise stipulated, the obligations under this Agreement are and will be independent of the obligations under the Contracts and such obligations of the Supplier hereunder will remain of full effect and validity notwithstanding that the period of validity of the Contracts has expired by efflux of time stipulated therein; or, the contract has been discharged by performance or breach; or, the termination of the Contracts for any reason whatsoever.
4. **Ownership:**
- 4.1 The Company may, from time to time, make available to the Supplier, Technical Information on a non-exclusive basis by way of loan.
 - 4.2 The Supplier acknowledges and agrees that all Technical Information and copies thereof that are or may be provided by the Company to the Supplier, are and shall remain the property of BHEL or that of the concerned entity from whom BHEL has obtained the Technical Information and such Technical Information are and shall constitute trade secrets of the BHEL. Nothing in this Agreement or in any disclosures made hereunder by or on behalf of the Company shall be construed as granting upon the Supplier any patent, copyright or design or any other intellectual property rights of whatsoever description that subsists or may hereinafter exist in the Technical Information. Furthermore, nothing in this Agreement or in any disclosures made hereunder by or on behalf of the Company shall be construed as granting upon the Supplier any license or rights of use of such patent, copyright or design or any other

intellectual property rights of whatsoever description which may now or hereafter exist in the Technical Information except for use of the Technical Information strictly in accordance with this Agreement and the Contract and/or as directed in writing by the Company, solely for the Intended Purpose under the Contract.

- 4.3 Neither Party is obligated by or under this Agreement to purchase from or provide to the other Party any service or product and that any such purchase/sale of any product and/or service by one Party to the other Party will be governed by the Contract if any, that may be entered into by and between the Company and the Supplier.
- 4.4 The Supplier is/has been made well aware and acknowledges that the Technical Information being/which may be shared with it by the Company has been either generated by the Company by incurring huge investment and cost or obtained from foreign collaborators under Technical Collaboration Agreement (TCA) with stringent confidentiality conditions.
- 4.5 The Supplier agrees and undertakes to adhere to confidentiality requirements as applicable to BHEL under a TCA and also ensure that the confidentiality requirements are adhered to by all its concerned employees or sub-contractors/suppliers (where permitted to be engaged by BHEL). Any damages, losses, expenses of any description whatsoever, arising out of or in connection with a breach of the confidentiality requirements under a TCA owing to any act or omission on the part of the Supplier or its employees or sub-contractors/suppliers that is claimed by a foreign collaborator from the Company shall be wholly borne by the Supplier and it shall keep BHEL fully indemnified in this behalf. The demand by the Company shall be conclusive upon the Supplier who shall thereupon forthwith pay to the Company without demur, dispute or delay the amount as demanded without demanding any further proof thereof.
- 4.6 The Supplier agrees and undertakes that unless so decided and advised by the Company in writing all rights/title to any Improvement to the Technical Information shall vest in the Company. The Supplier undertakes and agrees to inform forthwith to the Company of any such Improvement made to the Technical Information and transfer all drawings/documents or other materials connected with such Improvement to the Company and also agrees to fully cooperate with the Company for protecting the Company's interests in such Improvement in the Technical Information including but not limited to obtaining necessary protection for the intellectual property rights in such improvement, if so desired by the Company. If a question arises whether a modification amounts to Improvement to the Technical Information, the same shall be decided by the Company and such decision shall be final and binding upon the Supplier.

5. Use and Non-Disclosure:

- 5.1 Unless otherwise stipulated by the Company, all Technical Information made available to the Supplier, by the Company shall be treated as Confidential irrespective of whether the same is marked or otherwise denoted to be Confidential or not.

- 5.2 The Supplier undertakes and agrees that the Technical Information in its possession shall be held in strict confidence and will be used strictly in accordance with this Agreement and solely for the Intended Purpose under the Contract. Use of the Technical Information for any other purpose other than Intended Purpose is prohibited.
- 5.3 In particular, the Supplier shall not use Technical Information or any Improvement in its possession for the manufacture or procurement of the Product(s) or components or parts thereof or use the Technical Information or any portion thereof or any modification or adaptation thereof in any form to provide any product and/or service to any third party, without the prior written consent of the Company.
- 5.4 The Supplier shall not disclose any of such Technical Information to any third party without the prior written consent of the Company. The Supplier agrees that without prior written consent of the Company, the Supplier shall not disclose to a third party about the existence of this Agreement, or of the fact that it is/was in possession of or has experience in the use of any Technical Information nor shall the Supplier share in any manner whatsoever, with a third party, the name or details of any Contract(s) awarded by the Company to it or performed by the Supplier or the scope of work thereof or share any document or correspondence by and between the Company and the Supplier in or in connection with this Agreement or such Contract(s). Notwithstanding what is stated elsewhere, the overall responsibility of any breach of the confidentiality provisions under this Agreement shall rest with the Supplier.
- 5.5 The Supplier undertakes and agrees not to make copies or extracts of and not to disclose to others any or all of the Technical Information in its possession, except as follows:
- (a) The Supplier may disclose the Technical Information to such of its officers and employees strictly to the extent as is necessary for such officer or employee for the Intended Purpose, provided that the Confidential Information (or copies thereof) disclosed shall be marked clearly as the confidential and proprietary information of Company and that such officers and employees shall similarly be bound by undertakings of confidence, restricted use and non-disclosure in respect of the Technical Information. The Supplier shall be responsible for any breach of such confidentiality provisions by such officers and employees.
 - (b) With the prior written consent of Company, the Supplier may disclose for the Intended Purpose such Technical Information as is provided for in such consent to such of its professional advisers: consultants, insurers and subcontractors who shall be similarly bound by undertakings of confidence, restricted use and non-disclosure in respect of such Technical Information.
 - (c) The Supplier shall not be prevented to make any disclosure required by (i) order of a court of competent jurisdiction or (ii) any competent regulatory authority or agency where such disclosure is required by law, provided that where the Supplier

intends to make such disclosure, it shall first consult Company and take all reasonable steps requested by it to minimize the extent of the Technical Information disclosed and to make such disclosure in confidence and also shall cooperate with the Company in seeking any protective order or any other remedy from proper authority in this matter.

6. Exceptions:

The obligations of the Supplier pursuant to the provisions of this agreement shall not apply to any Confidential Information that:

- a) was/is known to, or in the possession of the Supplier prior to disclosure thereof by the Company;
- b) is or becomes publicly known, otherwise than as a result of a breach of this agreement by the Supplier.
- c) is developed independently of the Disclosing Party by the Supplier in circumstances that do not amount to a breach of the provisions of this Agreement or the Contract;
- d) is received from a third party in circumstances that do not result in a breach of the provisions of this Agreement.

7. The obligation of maintaining confidentiality of the Technical Information on each occasion, shall subsist for the entire duration during which the Technical Information / equipment is in possession of the Supplier and shall thereafter subsist for a further period of --- years from the date when the complete Technical Information has been returned to the Company and if Technical Information has been returned in portions on different dates then, the period of ---- years will be reckoned from the date when the last portion of the Technical Information has been returned. Notwithstanding the expiry of the confidentiality obligation, the obligation of the Supplier under clause 5.4 shall continue to subsist for a further period of ----- years.

8. Warranties & Undertakings:

a) The Supplier undertakes to ensure the due observance of the undertakings of confidence, restricted use and non-disclosure by its persons to whom it discloses or releases copies or extracts of the Technical Information.

b) The Supplier shall keep the Technical Information or improvement made therein properly segregated and not mix up the same with any other material/documents belonging to him/it or to any other third party.

c) The Supplier further undertakes that he/it shall not hypothecate or give on lease or otherwise alienate or do away with any of the Technical Information and/or equipment of the Company, made available to him/it, and undertakes that he/it shall hold the same as a trustee, in capacity of custodian thereof and use/utilise the same solely for the purpose of executing the Contract awarded by the Company.

d) The Supplier further undertakes that he/it shall return all the equipment and/or Technical Information as far as practicable in the same condition in which the same was made available to him/it by the Company together with any Improvement thereon and the documents connected with such Improvement, to the Company forthwith upon completion of the scope

of work or Contract for which such Technical Information was provided by the Company to it or as directed by the Company together with a confirmation by way of an affidavit or in such manner as directed by the Company that it has not retained any equipment and/or Technical Information/Improvement thereof. In case any such equipment and/or Technical Information or Improvement thereof shall remain in his possession or is not capable of being returned, the retention and use of such Technical Information or Improvement thereto shall continue to be governed by this Agreement.

e) The Supplier undertakes to indemnify the Company for all the direct, indirect and/or consequential losses, damages, expenses whatsoever including any consequential loss of business, profits suffered by the Company owing to breach by the Supplier of its obligations under this Agreement and/or the confidentiality requirements, if any, contained in the Contract and that the Supplier hereby agrees that the decision of the Company in all such or any such matter/s shall be final and binding on the Supplier. On mere written demand of the Company, the Supplier shall forthwith and without demur or delay pay to the Company any such sum as determined by the Company as the amount of loss or damage or expense which has been suffered by the Company. The Supplier agrees that the Company shall be entitled to withhold and appropriate any amount payable to the Supplier under any Contract then existing between the Company and the Supplier, in case the Supplier fails to make payment, in terms of the written demand, within 7 days thereof. Without prejudice to the foregoing actions, in respect to any breach of this Agreement, the Company shall be entitled to take any other action against the Supplier as per applicable laws, the Contract, Company's applicable policies, guidelines rules, procedures, etc.

9. Without prejudice to any other mode of recovery as may be available to the Company for recovery of the amount determined as due as per Clause 8(e) hereinabove, the Company shall have a right to withhold, recover and appropriate the amount due towards such losses, damages, expenses, from any amount due to the Supplier in respect of any other Contract (s) placed on him/it by any department/office/Unit/Division of the said Company.

10. Arbitration & Conciliation:

a) In case amicable settlement is not reached between the Parties, in respect of any dispute
or

difference or claim or controversy arising out of the formation, breach, termination, validity or execution of the Contract(or Agreement) or the respective rights and liabilities of the parties or in relation to interpretation of any provision of the Contract or in any manner touching upon the Contract, then, either Party may, by a notice in writing to the other Party refer such dispute or difference or controversy or claim, (except as to any matters, the decision of which is specifically provided for therein) to the sole arbitration by the arbitrator appointed by Head/In-Charge of the Unit/Division/Region.

b) The Arbitrator shall pass a reasoned award and the award of the Arbitrator shall be final and binding upon the parties to the dispute.

c) Subject as aforesaid, the provisions of Arbitration and Conciliation Act 1996 (India), or other statutory modifications or re enactments thereof and the rules made thereunder and for

the time being in force shall apply to the arbitration proceedings under this clause. The seat of arbitration shall be at ----- **(Insert the name of the city/town of the concerned BHEL Unit/Division).**

d) In case of Contract with Public Sector Enterprise (PSE) or a Government Department, the following shall be applicable:

In the event of any dispute or difference relating to the interpretation and application of the provisions of the Contract, such dispute or difference shall be referred to by either party to the arbitration of one of the arbitrators in the department of public enterprises to be nominated by the Secretary to the Government of India in-charge of the Department of Public Enterprises. The Arbitration and Conciliation Act, 1996 shall not be applicable to arbitration under this clause. The award of the arbitrator shall be binding upon the parties to the dispute, provided, however, any party aggrieved by such award may make further reference for setting aside or revision of the award to the Law Secretary, Department of Legal Affairs, Ministry of Law and Justice, Government of India. Upon such reference the dispute shall be decided by the Law Secretary or the Special Secretary or Additional Secretary when so authorized by the Law Secretary, whose decision shall bind the parties hereto finally and conclusively.

e) Notwithstanding the existence or any dispute or differences and/or reference for the arbitration, the Supplier shall proceed with and continue without hindrance the performance of its obligations under this Contract with due diligence and expedition in a professional manner.

11. Governing Law & Jurisdiction:

This Agreement shall be governed by and be construed as per applicable Indian Laws in force at the relevant time.

Subject to clauses 10(a) and 10(d) hereinabove, all matters in connection with the subject agreement shall be subject to exclusive jurisdiction of Courts situated at -----**(insert the name of the place where the BHEL Unit/Division is located)**

SIGNATURE

WITNESSES

1.

Name

Address:

2.

Name:

Address:

BANK GUARANTEE FOR PERFORMANCE SECURITY

Bank Guarantee No:

Date:

To

NAME

& ADDRESSES OF THE BENEFICIARY

Dear Sirs,

In consideration of Bharat Heavy Electricals Limited (hereinafter referred to as the 'Employer' which expression shall unless repugnant to the context or meaning thereof, include its successors and permitted assigns) incorporated under the Companies Act, 1956 and having its registered office at _____ through its Unit at.....(name of the Unit) having awarded to (Name of the Vendor / Contractor / Supplier) with its registered office at _____ hereinafter referred to as the 'Vendor / Contractor / Supplier', which expression shall unless repugnant to the context or meaning thereof, include its successors and permitted assigns), a contract Ref No.....dated valued at Rs..... (Rupees -----)/FC.....(in words.....) for (hereinafter called the 'Contract') and the Vendor / Contractor / Supplier having agreed to provide a Contract Performance Bank Guarantee, equivalent to% (... Percent) of the said value of the Contract to the Employer for the faithful performance of the Contract,

we, (hereinafter referred to as the Bank), having registered/Head office at and inter alia a branch at being the Guarantor under this Guarantee, hereby, irrevocably and unconditionally undertake to forthwith and immediately pay to the Employer any sum or sums upto a maximum amount of Rs ----- (Rupees -----) without any demur, immediately on first demand from the Employer and without any reservation, protest, and recourse and without the Employer needing to prove or demonstrate reasons for its such demand.

Any such demand made on the Bank shall be conclusive as regards the amount due and payable by the Bank under this guarantee. However, our liability under this guarantee shall be restricted to an amount not exceeding Rs. _____.

We undertake to pay to the Employer any money so demanded notwithstanding any dispute or disputes raised by the Vendor / Contractor / Supplier in any suit or proceeding pending before any Court or Tribunal, Arbitrator or any other authority, our liability under this present being absolute and unequivocal.

The payment so made by us under this Guarantee shall be a valid discharge of our liability for payment thereunder and the Vendor / Contractor / Supplier shall have no claim against us for making such payment.

We thebank further agree that the guarantee herein contained shall remain in full force and effect during the period that would be taken for the performance of the said Contract/satisfactory completion of the performance guarantee period as per the terms of the Contract and that it shall continue to be enforceable till all the dues of the Employer under or by virtue of the said Contract have been fully paid and its claims satisfied or discharged.

WeBANK further agree with the Employer that the Employer shall have the fullest liberty without our consent and without affecting in any manner our obligations hereunder to vary any of the terms and conditions of the said Contract or to extend time of performance by the said Vendor / Contractor / Supplier from time to time or to postpone for any time or from time to time any of the powers exercisable by the Employer against the said Vendor / Contractor / Supplier and to forbear or enforce any of the terms and conditions relating to the said Contract and we shall not be relieved from our liability by reason of any such variation, or extension being granted to the said Vendor / Contractor / Supplier or for any forbearance, act or omission on the part of the Employer or any indulgence by the Employer to the said Vendor / Contractor / Supplier or by any such matter or thing whatsoever which under the law relating to sureties would but for this provision have effect of so relieving us.

The Bank also agrees that the Employer at its option shall be entitled to enforce this Guarantee against the Bank as a principal debtor, in the first instance without proceeding against the Vendor / Contractor / Supplier and notwithstanding any security or other guarantee that the Employer may have in relation to the Vendor / Contractor / Supplier 's liabilities.

This Guarantee shall remain in force upto and including..... and shall be extended from time to time for such period as may be desired by Employer.

This Guarantee shall not be determined or affected by liquidation or winding up, dissolution or change of constitution or insolvency of the Vendor / Contractor / Supplier but shall in all respects and for all purposes be binding and operative until payment of all money payable to the Employer in terms thereof.

Unless a demand or claim under this guarantee is made on us in writing on or before thewe shall be discharged from all liabilities under this guarantee thereafter.

This Bank Guarantee shall be governed, construed and interpreted in accordance with the laws of India.

Courts at shall alone have exclusive jurisdiction over any matter arising out of or in connection with this Bank Guarantee

We, BANK lastly undertake not to revoke this guarantee during its currency except with the previous consent of the Employer in writing.

Notwithstanding anything to the contrary contained hereinabove:

- a) The liability of the Bank under this Guarantee shall not exceed.....
- b) This Guarantee shall be valid up to
- c) Unless the Bank is served a written claim or demand on or before _____ all rights under this guarantee shall be forfeited and the Bank shall be relieved and discharged from all liabilities under this guarantee irrespective of whether or not the original bank guarantee is returned to the Bank.

We, _____ Bank, have power to issue this Guarantee under law and the undersigned as a duly authorized person has full powers to sign this Guarantee on behalf of the Bank.

For and on behalf of
(Name of the Bank)

Dated.....

Place of Issue.....

¹ NAME AND ADDRESS OF EMPLOYER I.e Bharat Heavy Electricals Limited

² NAME AND ADDRESS OF THE VENDOR /CONTRACTOR / SUPPLIER.

³ DETAILS ABOUT THE NOTICE OF AWARD/CONTRACT REFERENCE

⁴ CONTRACT VALUE

⁵ PROJECT/SUPPLY DETAILS

⁶ BG AMOUNT IN FIGURES AND WORDS

⁷ VALIDITY DATE

⁸ DATE OF EXPIRY OF CLAIM PERIOD

Note:

1. Units are advised that expiry of claim period may be kept 3-6 months after validity date. It may be ensured that the same is in line with the agreement/ contract entered with the Vendor.
2. The BG should be on Non-Judicial Stamp paper/e-stamp paper of appropriate value as per Stamp Act prevailing in the State(s) where the BG is submitted or is to be acted upon or the rate prevailing in the State where the BG was executed, whichever is higher. The Stamp Paper/e-stamp paper shall be purchased in the name of Vendor/Contractor/Supplier /Bank issuing the guarantee.

ANNEXURE- 3

CERTIFICATE OF NO DEVIATION

(To be Typed & submitted in the Letter Head of the Company/Firm of Bidder)

To,

(Write Name & Address of Officer of BHEL inviting the Tender)

Dear Sir,

Subject: **No Deviation Certificate**

Ref: 1) GeM Bid No:
2) All other pertinent issues till date

We hereby confirm that we have not changed/ modified/materially altered any of the tender documents as downloaded from the website/ issued by BHEL and in case of such observance at any stage, it shall be treated as null and void.

We also hereby confirm that we have neither set any Terms and Conditions and nor have we taken any deviation from the Tender conditions together with other references applicable for the above referred GeM Bid.

We further confirm our unqualified acceptance to all Terms and Conditions, unqualified compliance to Tender Conditions.

We confirm to have submitted offer in accordance with tender instructions and as per aforesaid references.

Thanking you,

Yours faithfully,

(Signature, date & seal of authorized representative of the bidder)

Date:
Place:

INTEGRITY PACT**Between**

Bharat Heavy Electricals Ltd. (BHEL), a company registered under the Companies Act 1956 and having its registered office at "BHEL House", Siri Fort, New Delhi - 110049 (India) hereinafter referred to as "The Principal", which expression unless repugnant to the context or meaning hereof shall include its successors or assigns of the ONE PART

and

_____, (description of the party along with address), hereinafter referred to as "The Bidder/ Contractor" which expression unless repugnant to the context or meaning hereof shall include its successors or assigns of the OTHER PART

Preamble

The Principal intends to award, under laid-down organizational procedures, contract/s for _____

_____ (hereinafter referred to as "Contract"). The Principal values full compliance with all relevant laws of the land, rules and regulations, and the principles of economic use of resources, and of fairness and transparency in its relations with its Bidder(s)/ Contractor(s).

In order to achieve these goals, the Principal will appoint panel of Independent External Monitor(s) (IEMs), who will monitor the tender process and the execution of the contract for compliance with the principles mentioned above.

Section 1- Commitments of the Principal

- 1.1 The Principal commits itself to take all measures necessary to prevent corruption and to observe the following principles: -
 - 1.1.1 No employee of the Principal, personally or through family members, will in connection with the tender for, or the execution of a contract, demand, take a promise for or accept, for self or third person, any material or immaterial benefit which the person is not legally entitled to.
 - 1.1.2 The Principal will, during the tender process treat all Bidder(s) with equity and reason. The Principal will in particular, before and during the tender process, provide to all Bidder(s) the same information and will not provide to any Bidder(s) confidential/ additional information through which the Bidder(s) could obtain an advantage in relation to the tender process or the contract execution.
 - 1.1.3 The Principal will exclude from the process all known prejudiced persons.
- 1.2 If the Principal obtains information on the conduct of any of its employees which is a penal offence under the Bharatiya Nyaya Sanhita (BNS) 2023 and Prevention of Corruption Act 1988 or any other statutory penal enactment, or if there be a substantive suspicion in this regard, the Principal will inform its Vigilance Office and in addition can initiate disciplinary actions.

Section 2 - Commitments of the Bidder(s)/ Contractor(s)

- 2.1 The Bidder(s)/ Contractor(s) commit himself to take all measures necessary to prevent corruption. The Bidder(s)/ Contractor(s) commits himself to observe the following principles during participation in the tender process and during the contract execution.

- 2.1.1 The Bidder(s)/ Contractor(s) will not, directly or through any other person or firm, offer, promise or give to the Principal or to any of the Principal's employees involved in the tender process or the execution of the contract or to any third person any material, immaterial or any other benefit which he/ she is not legally entitled to, in order to obtain in exchange any advantage of any kind whatsoever during the tender process or during the execution of the contract.
- 2.1.2 The Bidder(s)/ Contractor(s) will not enter with other Bidder(s) into any illegal or undisclosed agreement or understanding, whether formal or informal. This applies in particular to prices, specifications, certifications, subsidiary contracts, submission or non-submission of bids or any other actions to restrict competitiveness or to introduce cartelization in the bidding process.
- 2.1.3 The Bidder(s)/ Contractor(s) will not commit any penal offence under the relevant Bharatiya Nyaya Sanhita (BNS) and Prevention of Corruption Act; further the Bidder(s)/ Contractor(s) will not use improperly, for purposes of competition or personal gain, or pass on to others, any information or document provided by the Principal as part of the business relationship, regarding plans, technical proposals and business details, including information contained or transmitted electronically.
- 2.1.4 Foreign Bidder(s)/ Contractor(s) shall disclose the name and address of agents and representatives in India and Indian Bidder(s)/ Contractor(s) to disclose their foreign principals or associates. The Bidder(s)/ Contractor(s) will, when presenting his bid, disclose any and all payments he has made, and is committed to or intends to make to agents, brokers or any other intermediaries in connection with the award of the contract.
- 2.2 The Bidder(s)/ Contractor(s) will not instigate third persons to commit offences outlined above or be an accessory to such offences.
- 2.3 The Bidder(s)/ Contractor(s) shall not approach the Courts while representing the matters to IEMs and shall await their decision in the matter.

Section 3 - Disqualification from tender process and exclusion from future contracts

If the Bidder(s)/ Contractor(s), before award or during execution has committed a transgression through a violation of Section 2 above, or acts in any other manner such as to put his reliability or credibility in question, the Principal is entitled to disqualify the Bidder(s)/ Contractor(s) from the tender process, terminate the contract, if already awarded, exclude from future business dealings and/ or take action as per the separate "Guidelines on Banning of Business dealings with Suppliers/ Contractors", framed by the Principal.

Section 4 - Compensation for Damages

- 4.1 If the Principal has disqualified the Bidder (s) from the tender process before award / order acceptance according to Section 3, the Principal is entitled to demand and recover the damages equivalent to Earnest Money Deposit/ Bid Security.
- 4.2 If the Principal is entitled to terminate the Contract according to Section 3, or terminates the Contract in application of Section 3 above, the Bidder(s)/ Contractor (s) transgression through a violation of Section 2 above shall be construed breach of contract and the Principal shall be entitled to demand and recover from the Contractor an amount equal to 5% of the contract value or the amount equivalent to Security Deposit/ Performance Bank Guarantee, whichever is higher, as damages, in addition to and without prejudice to its right to demand and recover compensation for any other loss or damages specified elsewhere in the contract.

Section 5 - Previous Transgression

- 5.1 The Bidder declares that no previous transgressions occurred in the last 3 (three) years (to be reckoned from date of bid submission) with any other company in any country conforming to the anti-corruption approach in India that could justify his exclusion from the tender process. The date of such transgression, for the purpose of disclosure by the bidders in this regard, would be the date on which cognizance of the said transgression was taken by the competent authority. The transgression(s), for which cognizance was taken even before the said period of three years, but are pending conclusion, shall also be reported by the bidders.
- 5.2 If the Bidder makes incorrect statement on this subject, he can be disqualified from the tender process or the contract, if already awarded, can be terminated for such reason or action can be taken as per the separate "Guidelines on Banning of Business dealings with Suppliers/ Contractors", framed by the Principal.

Section 6 - Equal treatment of all Bidder (s)/ Contractor (s) / Sub-contractor (s)

- 6.1 The Principal will enter into Integrity Pacts with identical conditions as this Integrity Pact with all Bidders and Contractors.
- 6.2 In case of a joint venture, all the partners of the joint venture should sign the Integrity Pact. In case of Sub-contracting, the Principal Contractor shall be solely responsible for the adherence to the provisions of IP by the sub-contractor(s).
- 6.3 The Principal will disqualify from the tender process all Bidders who do not sign this Integrity Pact or violate its provisions.

Section 7 - Criminal Charges against violating Bidders/ Contractors /Subcontractors

If the Principal obtains knowledge of conduct of a Bidder, Contractor or Subcontractor, or of an employee or a representative or an associate of a Bidder, Contractor or Subcontractor which constitutes corruption, or if the Principal has substantive suspicion in this regard, the Principal will inform the Vigilance Office.

Section 8 -Independent External Monitor(s)

- 8.1 The Principal appoints competent and credible panel of Independent External Monitor (s) (IEMs) for this Integrity Pact. The task of the IEMs is to review independently and objectively, whether and to what extent the parties comply with the obligations under this Integrity Pact on receipt of any complaint by them from the bidder(s).
- 8.2 The IEMs are not subject to instructions by the representatives of the parties and performs his functions neutrally and independently. He reports to the CMD, BHEL.
- 8.3 The IEMs shall be provided access to all documents/ records pertaining to the Contract, for which a complaint or issue is raised before them as and when warranted. However, the documents/records/information having National Security implications and those documents which have been classified as /Top Secret are not to be disclosed.
- 8.4 The Principal will provide to the IEMs sufficient information about all meetings among the parties related to the Contract provided such meetings could have an impact on the contractual relations between the Principal and the Contractor. The parties offer to the IEMs the option to participate in such meetings.
- 8.5 The role of IEM is advisory and the advice of IEM is non-binding on the Organization. However, as IEMs are invariably persons with rich experience who have retired as senior functionaries of the government, their advice would help in proper implementation of the IP.

- 8.6 For ensuring the desired transparency and objectivity in dealing with the complaints arising out of the tendering process, the matter should be examined by the full panel of IEMs jointly, who would look into the records, conduct an examination, and submit their joint recommendations to the Management. In case the full panel is not available due to some unavoidable reasons, the available IEM(s) will conduct examination of the complaints. Consent of the IEM(s), who may not be available, shall be taken on record.
- 8.7 The IEMs shall examine all the representations/grievances/ complaints received by them from the bidders or their authorized representative related to any discrimination on account of lack of fair play in modes of procurement and bidding systems, tendering method, eligibility conditions, bid evaluation criteria, commercial terms & conditions, choice of technology/ specifications etc.
- 8.8 The CMD, BHEL shall decide the compensation to be paid to the IEMs and its terms and conditions.
- 8.9 IEMs should examine the process integrity, they are not expected to concern themselves with fixing of responsibility of officers. Complaints alleging mala fide on the part of any officer of the Principal should be looked into by the CVO of the Principal.
- 8.10 If the IEMs have reported to the CMD, BHEL, a substantiated suspicion of an offence under relevant Bharatiya Nyaya Sanhita (BNS)/ Prevention of Corruption Act, and the CMD, BHEL has not, within reasonable time, taken visible action to proceed against such offence or reported it to the Vigilance Office, the IEMs may also transmit this information directly to the Central Vigilance Commissioner, Government of India.
- 8.11 After award of work, the IEMs shall look into any issue relating to execution of Contract, if specifically raised before them. As an illustrative example, if a Contractor who has been awarded the Contract, during the execution of Contract, raises issue of delayed payment etc. before the IEMs, the same shall be examined by the panel of IEMs.
- 8.12 However, the IEMs may suggest systemic improvements to the management of the Principal, if considered necessary, to bring about transparency, equity and fairness in the system of procurement.
- 8.13 The word 'Monitor' would include both singular and plural.

Section 9 - Pact Duration

- 9.1 This Integrity Pact shall be operative from the date this Integrity Pact is signed by both the parties. Any violation of the same would entail disqualification of the bidders and exclusion from future business dealings.
- 9.2 If any claim is made/ lodged during currency of this Integrity Pact, the same shall be binding and continue to be valid despite the lapse of this Pact as specified above, unless it is discharged/ determined by the CMD, BHEL.

Section 10 - Other Provisions

- 10.1 This Integrity Pact is subject to Indian Laws and exclusive jurisdiction shall be of the competent Courts as indicated in the Tender or Contract, as the case may be.
- 10.2 Changes and supplements as well as termination notices need to be made in writing.

- 10.3 If the Bidder(s)/ Contractor(s) is a partnership or a consortium or a joint venture, this Integrity Pact shall be signed by all partners of the partnership or joint venture or all consortium members.
- 10.4 Should one or several provisions of this Integrity Pact turn out to be invalid, the remainder of this Integrity Pact remains valid. In this case, the parties will strive to come to an agreement to their original intentions.
- 10.5 Only those bidders / contractors who have entered into this Integrity Pact with the Principal would be competent to participate in the bidding. In other words, entering into this Integrity Pact would be a preliminary qualification.
- 10.6 In the event of any dispute between the Principal and Bidder(s)/ Contractor(s) relating to the Contract, in case, both the parties are agreeable, they may try to settle dispute through Mediation before the panel of IEMs in a time bound manner. If required, the Principal may adopt any mediation rules for this purpose. However, not more than five meetings shall be held for a particular dispute resolution. The fees/expenses on dispute resolution shall be equally shared by both the parties. In case, the dispute remains unresolved even after mediation by the panel of IEMs, either party may take further action as the terms & conditions of the Contract.

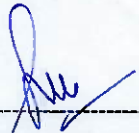

 For & On behalf of the Principal
 (Office Seal) *Sachin Gupta*
 Place Hardwar. *E2 (Pax-BSE)*
 Date _____ *BHEL-HWR*

Witness: _____
 (Name & Address) _____

For & On behalf of the Bidder/ Contractor
 (Office Seal)

Witness: _____
 (Name & Address) _____
