

ANNEXURE A PART I

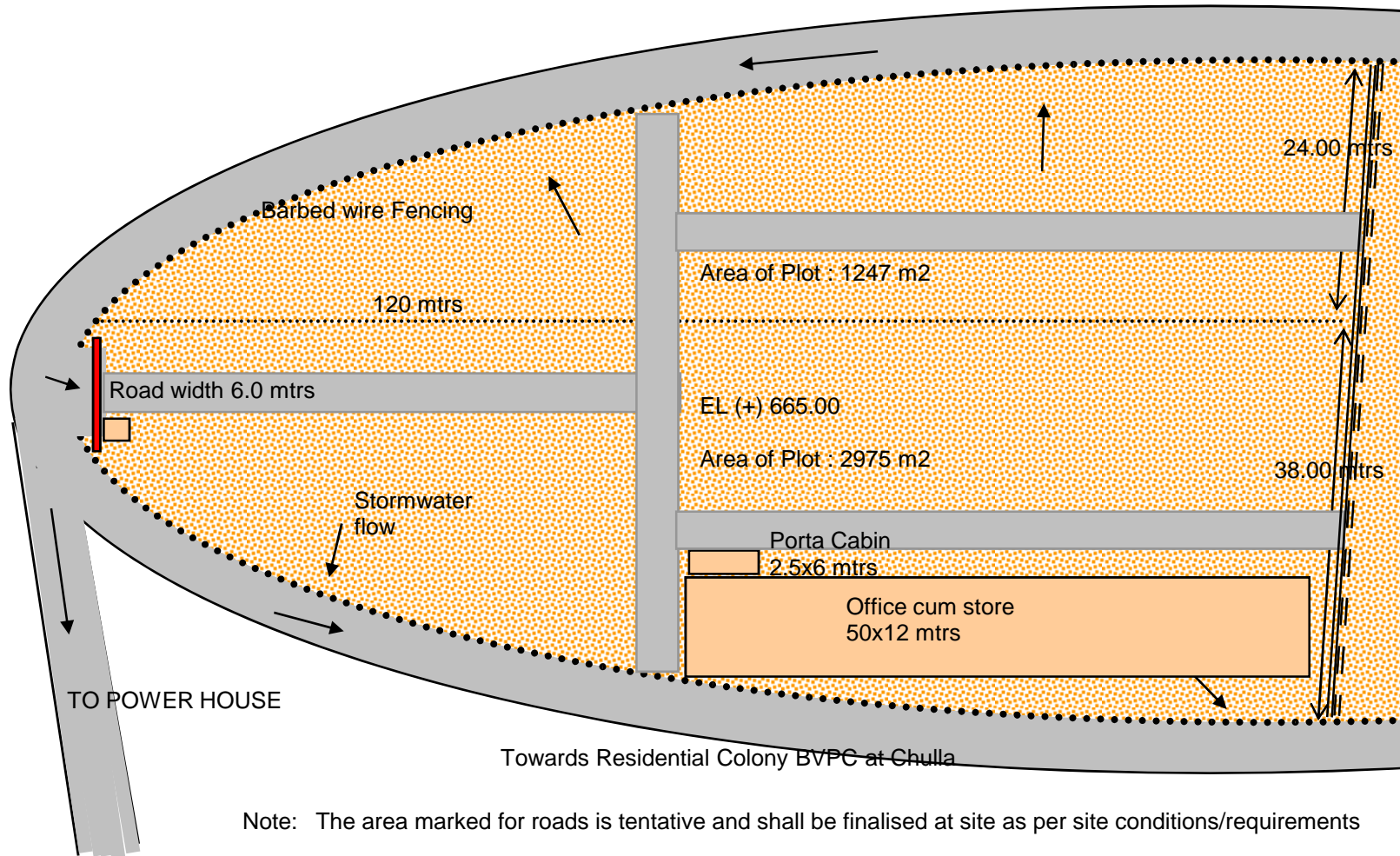

Note: The area marked for roads is tentative and shall be finalised at site as per site conditions/requirements

PROJECT: ENABLING WORKS AT UHL			TITLE: GA DRG FOR STORE W/O MOT		REV	DATE
ORG. NO.:UHL/SITE/001			Made by	KSB	OO	02.07.2008
Rev	oo	Checked by				
			Approved by			

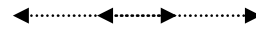

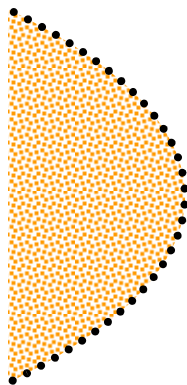



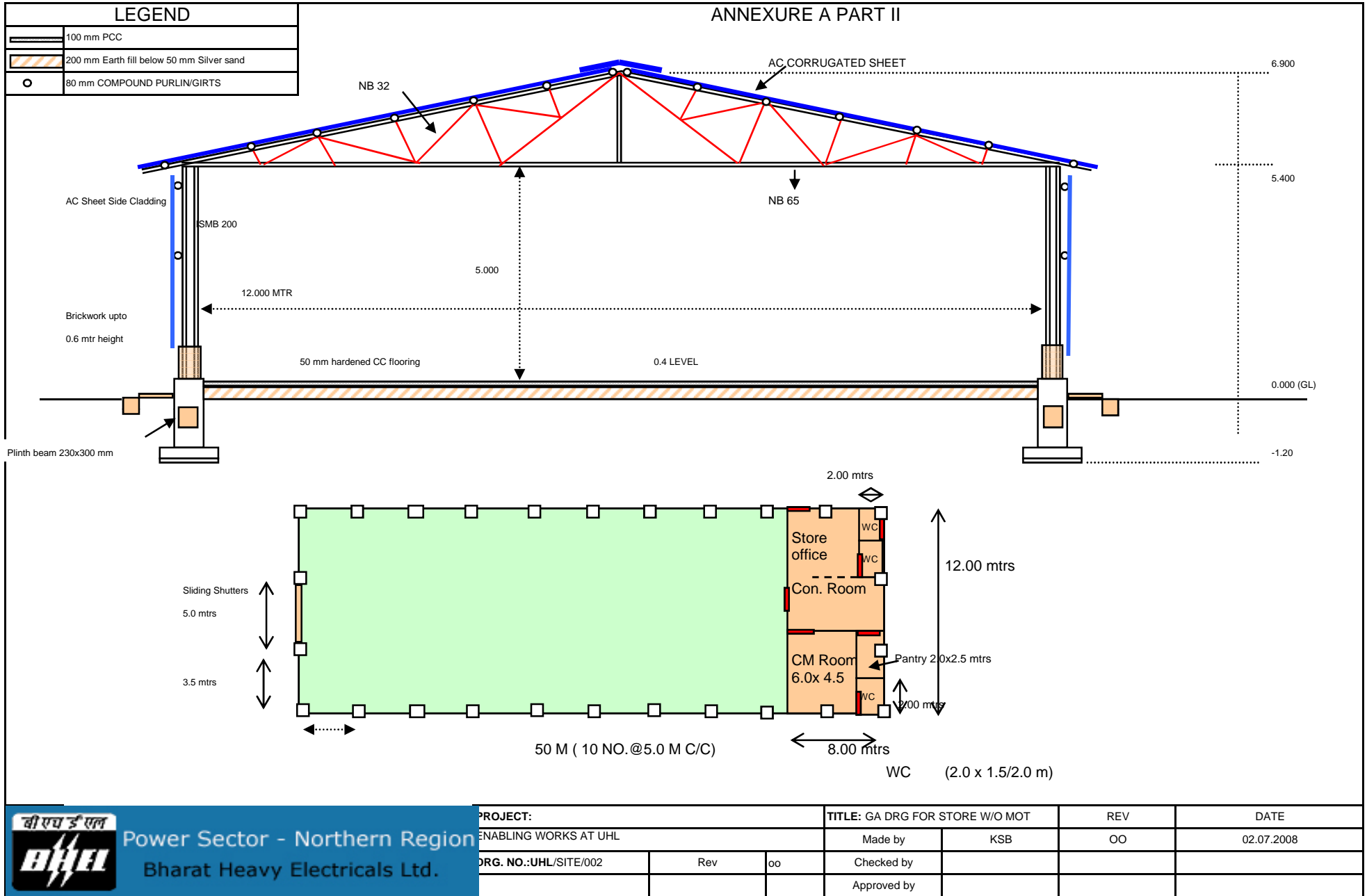

Power Sector - Northern Region  
 Bharat Heavy Electricals Ltd.

<b>PROJECT:</b> ENABLING WORKS AT UHL			<b>TITLE:</b> GA DRG FOR STORE W/O MOT		<b>REV</b>	<b>DATE</b>
ORG. NO.:UHL/SITE/002			Made by	KSB	OO	02.07.2008
Rev	oo	oo	Checked by			
			Approved by			

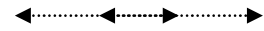

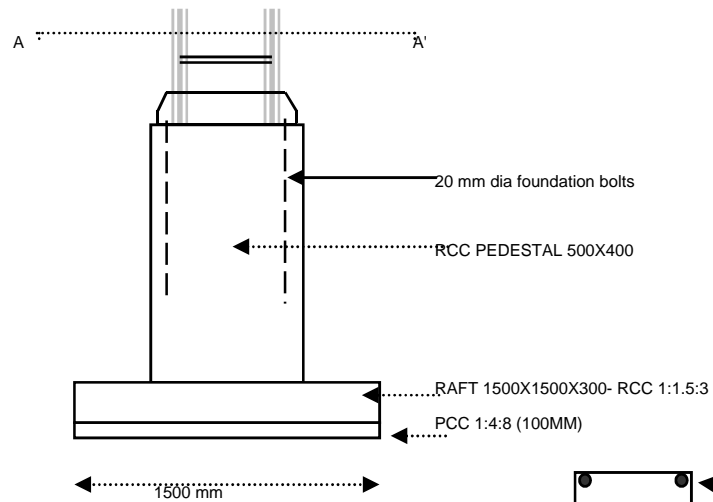

COLUMN FOOTING/PEDESTAL

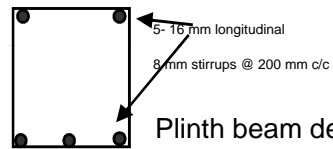

Plinth beam details

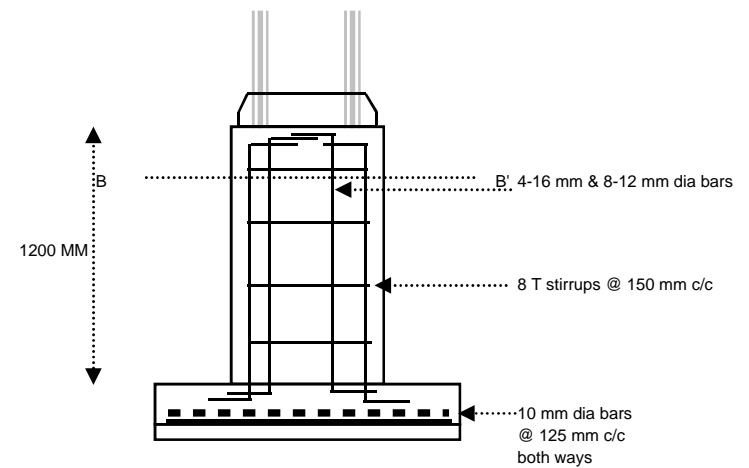

REINFORCEMENT DETAILS

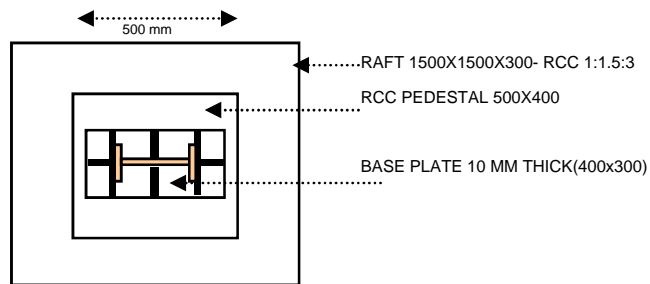

SECTION A-A'

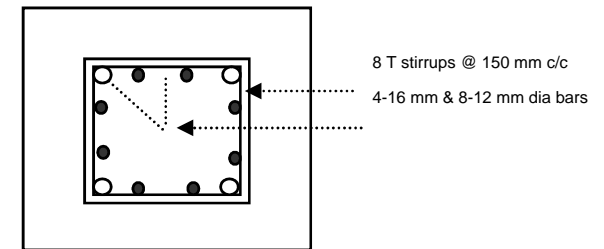

SECTION B-B'



Power Sector - Northern Region  
Bharat Heavy Electricals Ltd.

PROJECT:			TITLE: RCC WORK DETAILS		REV	DATE
ENABLING WORKS AT UHL			Made by	KSB	OO	02.07.2008
DRG. NO.:UHL/SITE/003	Rev	oo	Checked by			
			Approved by			