



Bharat Heavy Electricals Ltd.,
(A Government of India undertaking)
Electronics Division

PB 2606 , Mysore Road Bangalore , 560026 INDIA

Fx: +91 80 26989927

☎: +91 80 26998826

Tender Document for entering into Deed of Joint Undertaking for design, testing, supply ,installation, commissioning , warranty , AMC of APC (Advanced Process Control) package at NTPC's Simhadri Stg-I (2 X 500 MW) & Stg-II (2X500 MW) TPP

INDEX

Content	Page nos
BHEL TENDER DOC	1-5
BHEL SPECIFICATION	6-27
NTPC TENDER SPEC AND AMENDMENT	28-306
PRICE SCHEDULE	307-314



Bharat Heavy Electricals Ltd.,

(A Government of India undertaking)

Electronics Division

PB 2606 , Mysore Road Bangalore , 560026 INDIA

Fx: +91 80 26989927

☎: +91 80 26998826

Tender Document for entering into Deed of Joint Undertaking for design, testing, supply ,installation, commissioning , warranty , AMC of APC (Advanced Process Control) package at NTPC's Simhadri Stg-I (2 X 500 MW) & Stg-II (2X500 MW) TPP.

TENDER REFERENCE DOC	CE/APC-SOFTWARE/SIMHADRI/2018-19
TENDER DOCUMENT AVAILABLE FROM	20-Apr-2018
LAST DATE AND TIME FOR SUBMISSION OF TENDER	25-Apr-2018 upto 1300 Hrs IST
DATE AND TIME FOR TENDER OPENING	25-Apr- 2018 upto 1330 Hrs IST
SUBMISSION OF TENDER	<p>Two part bid to be submitted in sealed covers (or) password protected pdf files shall be sent via email.</p> <p>In case the bidder chooses to submit bid in sealed covers, the tender should be dropped in the tender box kept in reception, BHEL Electronics Division, Bangalore India</p> <p>For any clarification, pl contact the person whose details are given below.</p>

Contact Person at BHEL:Mr.Venkatarama Naik R(CE-Mktg) Ph: 080-26998826,9036065856,email:
venkataramnaik@bhel.in

Sub: Invitation for proposals for entering into Deed of Joint Undertaking for design, testing, supply, installation, commissioning ,warranty and AMC of APC (Advanced Process Control) package at NTPC Simhadri Stg-I (2 X 500 MW) & Stg-II(2X500 MW) TPP

REF: NTPC Tender document no 40086783 dtd 03.04.2018 due for submission on 01.05.2018

NTPC has floated a tender for design, testing, supply, installation, commissioning of APC (Advanced Process Control) package for Stg-I (2 X 500 MW) & Stg-II(2X500 MW), Vishakapatnam District, India. BHEL Electronics Division is participating in the aforementioned tender. Tender document of NTPC (REF: 40086783) is enclosed for your reference. This document may not, without the consent of the Disclosing party, otherwise be used or copied, reproduced, transmitted or communicated to third parties. All information and data contained in general product documentation, whether in electronic or any other form, are binding only to the extent that they are by reference expressly included in the contract

BHEL proposes to enter into a Deed of Joint Undertaking (DJU) with a suitable associate for supply of this APC software as per CI 7.1.2 (Route 2) in the said tender .

Bids are invited in two parts from prospective associates:

1. Part 1 bid :Techno- commercial Bid including Documents in support of Qualification criteria in a sealed envelope (or) password protected.pdf file shall be sent to the following email ids: amit.joel@bhel.in , shanmuga@bhel.in, srinivasan.r@bhel.in , venkataramnaik@bhel.in
2. Part 2 bid: Price bid as per the attached price bid schedule in a sealed envelope (or) password protected.pdf file shall be sent to the following email ids: amit.joel@bhel.in , shanmuga@bhel.in , srinivasan.r@bhel.in , venkataramnaik@bhel.in

Quotation shall be submitted in sealed envelopes. Both these envelopes shall be again kept inside separate sealed envelope. Bidder shall ensure to superscribe the envelope with RFQ number, RFQ date, RFQ due date, (type of Bid-if applicable) on all the covers. Tender should be dropped in the tender box , kept in the reception before 13 hours on the due date. For any query, pl contact BHEL person indicated in this tender document.

Vendor who is shortlisted shall be prepared to come over to BHEL- Electronics Division, bangalore at very short notice to negotiate prices and sign the Deed of Joint Undertaking by 26-Apr-2018.

The following documents are enclosed:

1. NTPC Tender document no 40086783 dtd 03.04.2018 and amendment 01
2. NTPC Commercial terms and conditions.
3. Technical specification of BHEL doc ref: PS4182060 rev 00.
4. Price schedule format.

Commercial terms and conditions:

This RFQ is governed by the terms and conditions as laid out in the NTPC tender document no 40086783 dtd 03.04.2018.

1. TECHNO-COMMERCIAL BID

(A)The following documents are required to be submitted in Part-1 bid(Techno – commercial bid):		
S. no	Description	Format
1	Technical qualification criteria (along with Client Certificates stating that associate is meeting all the technical requirements as per QR)	IFB Clause 7.1.2 , Attachment 7A in Forms /Bid Data Sheet in Volume-I Section - IV of NTPC tender doc no 40086783 along with all supporting documents.
2	Financial Qualification criteria	IFB Clause 7.3.0, Attachment 7B-2 in Forms /Bid Data Sheet in Volume-I Section - IV of NTPC tender doc no 40086783 along with all supporting documents.
3	Confirmation to the technical specification	Volume-III section I of NTPC tender doc no 40086783.Please provide clause wise confirmation.
4	Confirmation regarding submission of JDU (during tendering) and PBG (after award of contract)	Attachment – 7C-1, 7C-2, 7C-3 & Attachment – 3 B.
5	Acceptance of Clauses related to Non-Disclosure undertaking & Integrity pact of tender	Attachment 7D & Integrity pact document of NTPC : Acceptance of clauses.
6	Confirmation to General Purchase conditions and Special Purchase conditions applicable for Associate	NTPC tender doc no 40086783.
7	Confirmation to the milestone schedule	Attachment 10 in Forms /Bid Data Sheet in Volume-I Section - IV of NTPC tender doc no 40086783 along with all supporting documents.
8	Certificate For Compliance To All Provisions Of Bidding Documents (Certificate of "NIL" Deviation	Attachment 14 in Forms /Bid Data Sheet in Volume-I Section - IV of NTPC tender doc no 40086783 along with all supporting documents.

(B) Payment terms will be as per cl.39 of Special Purchase Conditions of Procurement of NTPC Tender Doc no 40086783. Since BHEL and the associate partner will be jointly responsible for completion of milestone activities, payment will be made after producing the minutes of the meeting copy (jointly signed by BHEL, Associate and NTPC representative) for milestone activities.

(C) Evaluation of bids will be based on as per CI 41-48 of Special Purchase Conditions of Procurement of NTPC Tender Doc no 40086783.

(D) For evaluation of offers in foreign currency, the exchange rate (TT selling rate of SBI) shall be taken as under: Date of Part-I bid opening date.

If the relevant day happens to be a bank holiday, then the exchange rate as on the previous working day of the bank (SBI) shall be taken.

(E) Any penalty/liquidation damages levied on BHEL as laid out in the NTPC's tender document, corresponding penalty/liquidation damage will be levied on the associate.

(F) Delivery of the APC package to the project site is in the scope of vendor.

(G) Price has to be quoted in unit package wise as called in NTPC tender doc 40086783

(H) In the event of BHEL being awarded with this contract from NTPC, all the Terms and conditions called as per the said NTPC tender document will be applicable for the associate. Also, in the event of price reduction during negotiation by BHEL with NTPC, corresponding reduction will be passed on to the associate. Within 30 days of signing the DJU, 1% of the value of DJU shall be submitted in the form of bank guarantee to BHEL

(i) BHEL prefers to deal directly with Original Equipment Manufacturers (OEMs) / Principal for all its purchases. However, if the OEM / Principal insist on engaging the services of an Agent/Representative, such Agent / Representative will be allowed to represent only one OEM / Principal in the same tender. Either the Agent / Representative could bid on behalf of the OEM / Principal or the OEM / Principal could bid directly but not both. In case bids are received from both the OEM / Principal and the Agent/ Representative, the bid received from the Agent/Representative will be ignored. Agent/Representative authorized by the OEM/Principal in turn cannot further sub authorize any other firm for submitting the offer or for placement of order. Valid Authorization letter from the OEM / Principal to quote and negotiate on behalf of OEM / Principal to be submitted by the respective Agent/Representative.

(J) The associate shall not engage the services of the firms banned by BHEL/NTPC. List of such banned firms is available at website www.bhel.com and <http://www.ntpctender.com> .

(K) The associate shall strictly adhere to BHEL/NTPC Fraud Prevention Policy displayed on BHEL/NTPC website www.bhel.com and <http://www.ntpctender.com> and shall immediately bring to the notice of BHEL Management about any fraud or suspected fraud as soon as it comes to their notice.

(L) GST TIN no (for Indian bidder) has to be provided in the Techno-commercial bid.

(M) Certificate For Compliance To All Provisions Of Bidding Documents (Certificate of "NIL" Deviation) has to be submitted in techno-commercial bid.

2. PRICE BID:

Price bid has to be submitted in the price schedule format enclosed with this tender. For the schedule of prices , pl refer to NTPC IFB Tender Doc Ref 40086783 Price schedule cl 25 in the Special Provisions of Contract Vol II Section-I APC.

In the event of BHEL being awarded with this contract from NTPC, all the Terms and conditions called as per the NTPC tender document no 40086783 will be applicable for the associate partner. Bidders are required to sign the entire tender document of NTPC enclosed for having read and understood that terms and conditions of this enquiry.

BHEL reserves the right to reject the offer , if the offer is not complying to the terms and conditions of this enquiry.



**SPECIFICATION FOR ADVANCE
PROCESS CONTROL
PACKAGES**

PS4182060

Rev 00

Page 01 of 22

COPYRIGHT AND CONFIDENTIAL
This information on this document is the property of Bharat Heavy Electricals Limited
It must not be used directly or indirectly in any way detrimental to the interest

TITLE :

SPECIFICATION FOR ADVANCE PROCESS CONTROL PACKAGES

APPROVED
Sai Kumar

Prepared
AS

Checked
AJ

Issued
BHEL

Date
18.04.18



SPECIFICATION FOR ADVANCE PROCESS CONTROL PACKAGES

PS4182060

Rev 00

Page 2 of 22

COPYRIGHT AND CONFIDENTIAL

This information on this document is the property of Bharat Heavy Electricals Limited
It must not be used directly or indirectly in any way detrimental to the interest

Project Information

Simhadri Super thermal power project stage-I (2 X 500 MW) serves states of Andhra Pradesh and Telangana and Stage-II (2 X 500 MW) serves states/UTs of southern region. The project is located in Parawada mandal of Vishakapatnam District. The Project is approachable from Vishakapatnam-Yelamanchali state highway. Nearest Railway station is Anakapalle(23 Kms)/Visakhapatnam (37 Kms). The nearest airport is Vishakapatnam, at a distance of about 30 kms from the project.

Details of Main Plant

Boiler-M/s BHEL(CE Design),Controlled Circulation With Rifled-Tubing, Dry-Bottom, Radiant Reheat, Single Drum, Top Supported,Dry botton, Balanced Draft Furnace of volume

16424 M3,Depth 15.797 M , Width 19.177 M. Turbine-M/s BHEL(KWU Design),Three Cylinder Reheat Condensing Turbine,HPT 17 Reaction stages,IPT 12 X 2 Reaction stages,LPT 6 X 2 Reaction stages.HPT-2Nos Main Stop and Control Valves,IPT -2 Nos RH Stop and Control Valve,CRH line – 1 Swing Check Valve,LPBP–2 Nos Bypass Stop and Control Valves. Condenser is cooled with sea water in closed loop using natural draft cooling towers



SPECIFICATION FOR ADVANCE PROCESS CONTROL PACKAGES

PS4182060

Rev 00

Page 3 of 22

Brief Scope of Work & other specific detail

Advanced Process Control-(APC) Package for SIMHADRI Stg-I (2 X 500 MW) & Stg-II(2X500 MW) for Design , testing, supply, installation, commissioning of APC (Advanced Process Control) Package.

The Bidder should have Supplied and Commissioned Advanced Process Control package for the following:

- A. Combustion optimization, in closed loop which should have been in successful operation in at least one (1) unit of pulverized coal fired station having unit rating of 200 MW or above, for a period of not less than one (1) year prior to the date of bid opening.
- B. Soot Blowing Optimization, in closed loop which should have been in successful operation in at least one (1) unit of pulverized coal fired station having unit rating of 200 MW or above, for a period of not less than one (1) year prior to the date of bid opening.
- C. Faster load Ramp-up/Ramp-down, in closed loop which should have been in successful operation in at least one (1) unit of pulverized coal fired station having unit rating of 200 MW or above, for a period of not less than one (1) year prior to the date of bid opening.

OR

SH/RH Temperature Excursion Reduction, in closed loop which should have been in successful operation in at least one (1) unit of pulverized coal fired station having unit rating of 200 MW or above, for a period of not less than one (1) year prior to the date of bid opening.

COPYRIGHT AND CONFIDENTIAL
This information on this document is the property of Bharat Heavy Electricals Limited
It must not be used directly or indirectly in any way detrimental to the interest



SPECIFICATION FOR ADVANCE PROCESS CONTROL PACKAGES

PS4182060

Rev 00

Page 4 of 22

Intent of Specification:

Employer intends to procure APC (Advanced Process Control) software solution in each of the 4 (four) 500MW units of Simhadri Super Thermal Power Station for improving the heat rate, environmental compliance, faster load ramp up/ ramp down, achieving tighter steam temperature controls especially during disturbances and reducing minimum stable unit load, through the use of advanced control algorithms.

The main objectives of the APC solution is given below:

- 1.1. Combustion Optimization – To increase the Unit heat rate, reduce NO_x by combustion optimization of boiler while maintaining flame stability, CO limits and rated parameters of SH steam temperature, RH steam temperature and avoiding metal temperature excursions.
- 1.2. Soot Blowing Optimization – To increase the Unit heat rate by optimizing operation of Soot blowers (wall blower, long range and APH).
- 1.3. Faster load Ramp up/Ramp Down – To achieve faster ramp rates, through the development of advanced models of the Boiler response characteristics, while maintaining the rated parameters of MS pressure, SH steam temperature and RH steam temperature.
- 1.4. SH/RH Temperature Excursion Reduction - Temperature variations during load change and unit disturbances shall be regulated through the development of advanced models of the steam temperature processes while maintaining limits on SH & RH metal temperatures.
- 1.5. Reduce Min stable load – Improve control loop performance to allow stable unit operation with all control loops in auto at lower loads without oil support while maintaining flame stability.

The above APC software is to be implemented in closed loop.

2.0 Definitions/ Abbreviations

- 2.1. Advanced Process Control (APC) shall mean the set of techniques which use a multiple input multiple output predictive model for improving the existing performance of the control loops w.r.t the desired objective (i.e. efficiency improvement or emissions reduction etc). The model can be first principles based, empirical or ANN (artificial neural network) or fuzzy logic based.
- 2.2. Combustion Optimization shall include optimizing the flue gas O₂ trim, air registers, and feeder rate bias in order to improve heat rate/reduce NO_x.
- 2.3. Faster load ramp up/ ramp down shall mean using APC for main steam pressure control loop. This shall include achieving tighter throttle pressure and temperature control during load changes.
- 2.4. SH/RH temperature excursion reduction shall mean using APC for SH/RH spray control loop.
This shall include achieving tighter steam temperature controls during unit disturbances.
- 2.5. Standard deviation from set-point shall be calculated as the square root of variance. Variance shall be determined as summation of squared values of the variation between each data point relative to the set-point of the respective data point.
- 2.6. CVs – Controlled variables, MVs – Manipulated variables and DVs – Disturbance Variables.

COPYRIGHT AND CONFIDENTIAL
This information on this document is the property of Bharat Heavy Electricals Limited
It must not be used directly or indirectly in any way detrimental to the interest



SPECIFICATION FOR ADVANCE PROCESS CONTROL PACKAGES

PS4182060

Rev 00

Page 5 of 22

3.0 Project Information

3.1. Simhadri Super thermal power project stage-I (2 X 500 MW) serves states of Andhra Pradesh and Telangana and Stage-II (2 X 500 MW) serves states/UTs of southern region. The project is located in Parawada mandal of Vishakapatnam District. The Project is approachable from Vishakapatnam-Yelamanchali state highway. Nearest Railway station is Anakapalle(23 Kms)/Visakhapatnam (37 Kms). The nearest airport is Vishakapatnam, at a distance of about 30 kms from the project.

3.2. Details of Main Plant

Boiler-M/s BHEL(CE Design),Controlled Circulation With Rifled-Tubing, Dry-Bottom, Radiant Reheat, Single Drum, Top Supported,Dry botton, Balanced Draft Furnace of volume 16424 M3,Depth 15.797 M , Width 19.177 M. Turbine-M/s BHEL(KWU Design),Three Cylinder Reheat Condensing Turbine,HPT 17 Reaction stages,IPT 12 X 2 Reaction stages,LPT 6 X 2 Reaction stages.HPT-2Nos Main Stop and Control Valves,IPT -2 Nos RH Stop and Control Valve,CRH line – 1 Swing Check Valve,LPBP-2 Nos Bypass Stop and Control Valves. Condenser is cooled with sea water in closed loop using natural draft cooling towers.

3.3. Historical Operation Data

The available historical data of the APC related tags of last one year shall be provided to the Bidder on a CD subject to the Bidder signing a non-disclosure agreement/undertaking for maintaining strict confidentiality of the data provided. Any other data required by the Contractor/Bidder shall be provided on request basis, subject to Employer's approval.

3.4. Details of existing DCS and interfacing with APC are provided in Annexure-I.

4.0 Scope of Work:

4.1. Contractor's scope under this package shall include but not be limited to design, testing, supply, installation, commissioning of APC (Advanced Process Control) software for each of the Four(4) units of Simhadri Super Power Station, along with required hardware, interface software and training as per specifications laid down in this tender document.

4.2. The Bidder shall provide all the related services for design, development/configuration, implementation, installation of software and control scheme, performance testing, training, warranty, AMC etc.

4.3. The requirements for APC are indicated on functional basis in the specification. Refer Section 6 for details of APC functional requirements. Contractor shall be responsible for engineering, selection and connection of all components and subsystems to form a complete system whose performance is in accordance with functional, hardware and other requirements of these specifications. It is not the intent or purpose of this specification to specify all individual system components since the Contractor has full responsibility for engineering and furnishing of a complete system to meet the objectives laid down in this specification.

4.4. As a min., one (1) no. Operator station of APC (to be placed in unit control room) and one (1) no. engineering station (to be placed in programmer room) are to be provided for each Unit.

4.5. Each unit shall have individual APC hardware i.e. intermixing of same hardware for more than one unit shall not be allowed. However, to implement remote connectivity, equipment can be common for multiple units. The hardware shall be sufficient to meet all the functional requirements of this specification.

4.6. All the cables (along with all connecting equipment) from Contractor's APC system to the Employer's DCS shall be in the scope of the Contractor. This shall also include power cables from Employer's ACDB/DCDB to Contractor's equipment.



SPECIFICATION FOR ADVANCE PROCESS CONTROL PACKAGES

PS4182060

Rev 00

Page 6 of 22

COPYRIGHT AND CONFIDENTIAL

This information on this document is the property of Bharat Heavy Electricals Limited
It must not be used directly or indirectly in any way detrimental to the interest

4.7. In addition to the hardware for APC (servers, workstations, controllers etc), furniture including tables and chairs shall also be provided. Controllers/ Electronic modules, if provided, shall be housed inside modular racks/panels. The exact arrangement shall be subjected to Employer's approval during kick off meeting.

4.8. All software required to achieve the above functional requirements shall be included in the scope of this package and shall be provided to Employer with lifetime licenses in CD/DVD media or any other downloadable format. These shall be site license including the operating system, modelling and optimization software and any other software required for proper functionality of the complete system.

4.9. The software licenses shall not be hardware/machine-specific. That is, if any hardware/machine is upgraded or changed, the same license shall hold good and it shall not be necessary for Employer to seek a new license/renew license due to upgradation/change of hardware/machine for APC at site.

4.10. The offered APC software should utilize latest hardware and software versions. The operating system should also be latest available like Windows 10.

4.11. Software updates including new releases, versions, fixes, patches etc. shall be provided as and when released by the contractor without any additional cost to NTPC during the warranty period and also during the AMC period. These shall include operating system patches, antivirus software/signatures, firewall software/signatures.

4.12. In case, the version available at the time of supply and commissioning is not compatible to latest OS version, then the Contractor should upgrade all the software to latest OS version, when the same is available, without any additional cost before the end of warranty period.

4.13. The interpretation of the Employer in respect of the scope, details and services to be performed by the Contractor shall be binding, unless specifically clarified otherwise by the Employer in writing during the bidding stage.

5.0 Terminal Points and Exclusions:

5.1. **Terminal Points:**

1. Upto Employer's interface card(s) in DCS
2. Employer's existing one no feeder of 230 V AC UPS ACDB/PDB for extending power to
3. Bidder's APC equipment.
4. Employer's existing one no feeder of 24 V DC DCDB for extending power to Bidder's APC Equipment .

5.2. **Exclusions:**

1. 230 V AC Power supply, 24 V DC Power supply.
2. All modifications in the existing control scheme as per clause 6.19.1.

6.0 **Functional Requirements:**

Advanced Process Control (APC) shall consist of the following:

6.1. **Combustion Optimization**

6.1.1. The combustion optimization APC software needs to be tuned to optimize for both scenarios (i) Heat rate, (ii) Nox. The facility to select the desired objective among the two should be selectable by Operator from DCS workstation/APC workstation. The performance testing shall be conducted by selecting Heat rate as optimization objective.

6.2. **Soot Blowing Optimization**



SPECIFICATION FOR ADVANCE PROCESS CONTROL PACKAGES

PS4182060

Rev 00

Page 7 of 22

6.2.1. Soot blowing optimization, when put in closed loop, should raise an alarm to operator in DCS at least 30 min prior to carrying out Soot blowing operation, to provide sufficient time to ensure local monitoring, as required.

6.3. **Faster load Ramp up/Ramp Down**

6.3.1. Faster load ramp up/ ramp down shall mean using APC for main steam pressure control loop. This shall include achieving tighter throttle pressure and temperature control during load changes.

6.4. **SH/RH Temperature Excursion reduction**

6.4.1. SH/RH temperature excursion reduction shall mean using APC for SH/RH spray control loop.

This shall include achieving tighter steam temperature controls during unit disturbances.

6.5. **Reduce Min stable load**

6.5.1. Improve control loop performance to allow stable unit operation with all control loops in auto at lower loads without oil support while maintaining flame stability.

6.6. **Interfacing with Existing DCS:**

6.6.1. The APC software shall interface in real time with the existing DCS of each of the Simhadri units through MODBUS TCP/IP for collecting data and sending commands back to DCS for changing the bias/setpoints /controller outputs of the closed loop controls in the existing DCS.

6.6.2. Typical outputs from the APC shall include Aux. air damper bias, Overfire air damper bias, burner tilt bias, Feeder bias, FG O2 SP bias, Fuel Master SP bias, CMC Load SP to TG bias etc. For SH/RH steam temperature, the outputs shall be either spray demand bias or direct output switchover. Bidder to include detailed scheme of the APC indicating the input tags from DCS as well the output tags from the APC system. The exact APC scheme along with the signal exchange list between APC and DCS shall be finalized with the Employer during kick off/ engineering stage.

6.6.3. Typical interfacing scheme with existing DCS is attached as drawing 001 and 002.

6.7. All set-point/bias adjustment would be in the range of acceptable limits finalized during design/engineering, not exceeding 10% of the operator provided set-points.

6.8. The Contractor shall take into account all regimes of the operation of the units during the design of his APC system. Further, all constraints of the units shall be taken into consideration during the APC design. The improvements intended are w.r.t the 'AS IS' state of the plant.

6.9. The APC shall not violate any of the physical, operational, metallurgical constraints of any plant equipment. It shall ensure safe and stable control technologies so that it does not cause physical damage to the equipments.

6.10. The APC software shall not result in deterioration of existing control loop performance or unit parameters in any way.

6.11. The APC solutions offered should not require any mechanical modification in the plant.

6.12. Further, Bidder should familiarize with the measurements existing at site. The model should be able to deliver the benefits based on the existing measurements. Bidder to provide CO Analyzer at Economizer outlet (L/R) - 2 (Two) No. per Unit. Installation of additional sensors and associated works would be permitted, subject to Employer's approval during engineering. Supply and installation shall be in Contractor's scope without any additional cost implication to Employer.

6.13. The APC software should have adaptive control features i.e. it should take into account actual unit conditions and constraints for giving the bias/set-points/control outputs. The APC model should be self-tuning to automatically adjust to actual unit conditions and constraints. Bidder to submit write-up in the bid explaining how the same is achieved.

6.14. Employer shall try their best to provide any other data relevant to the development of APC.



SPECIFICATION FOR ADVANCE PROCESS CONTROL PACKAGES

PS4182060

Rev 00

Page 8 of 22

However, non-availability of design data shall not be a bottleneck to implementation of APC.

6.15. GUI for the APC: The software should have graphic displays to control the execution of the optimization solution and perform following functions:

- 6.15.1. Viewing the constraints
- 6.15.2. Enabling/ Disabling the constraints with proper security privileges
- 6.15.3. Enable/Disabling the APC solution with bumpless transfer to existing DDCMIS.
- 6.15.4. Facility of creating custom displays shall be provided.
- 6.15.5. The APC should be capable of handling on line changes in control objectives (constraint limit changes/ priority changes/ set point or range target changes) without switching off the APC.
- 6.15.6. Trends for process values, APC parameters etc., alarm page for showing alarms generated by APC software.

6.16. Historization of APC inputs, calculated values and outputs i.e all CVs, MVs and DVs.

6.17. Snapshot of best achievable performance (i.e Heat rate) in a given set of conditions to be available in the APC software.

6.18. KPIs of APC being generated in APC software shall also to be transferred to existing DCS over the interface link. These shall be configured in existing Station LAN server for sending to PI and dashboard shall be created in PI for monitoring performance of APC software.

6.19. In existing DCS Operation workstations, suitable graphics shall be built by Employer, as per the suggestions of the contractor, in order for operator to monitor and access the optimizer information easily. Operator should be able to easily switch APC ON/OFF.

6.20. The Contractor shall furnish the red lined modifications in the existing control schemes of the DCS. This shall cover the following two broad cases:

6.20.1. Switchover between Conventional control and APC for the bias/set-point/controller output, as per the scheme approved by the Employer.

6.20.2. Improvements in the existing Control schemes including any adaptive control logic for reducing min. stable load as well as enhancing the objectives of APC. Implementation of these shall be done after completion of SAT of all other APC software.

6.21. **Fail safe design:** APC implementation should ensure fail safe design, so that in case the operating conditions are away from zone of optimization or in case of malfunction of APC or failure of communication link, the control functionality of existing DDCMIS, as without APC is maintained. In order to ensure this, each of the above APC solution should have individual 'start/stop' functionality. In the above scenario, the respective APC solution will automatically 'stop' with bumpless transfer to existing DDCMIS and give alarm to operator. Suitable setpoint and bias tracking functions also to be implemented.

6.22. A permissive shall be built for APC ON in the existing DCS to check the Unit stability and APC shall be put on only when this permissive is available.

6.23. **Watchdog:** Suitable watchdog logic to be incorporated for healthiness of the optimizer. It shall be ensured that in case of failure of APC or its communication interface, there shall be no bump in the existing controls. In case of APC ON, the DCS shall track the APC signals and in case of APC OFF, the APC signal shall track the DCS signals. Annunciation indicating any failure of APC shall be provided for display in the LVS (Large Video screen).

6.24. Direct interfacing with the existing DCS, i.e APC node directly sitting on existing DCS network, can be proposed by the Bidder, if the Bidder is OEM of existing DCS, subject to Employer's approval. In such a case, the Bidder has to produce documentary evidence to establish that similar architecture is in service in an existing installation.

COPYRIGHT AND CONFIDENTIAL

This information on this document is the property of Bharat Heavy Electricals Limited
It must not be used directly or indirectly in any way detrimental to the interest



SPECIFICATION FOR ADVANCE PROCESS CONTROL PACKAGES

PS4182060

Rev 00

Page 9 of 22

COPYRIGHT AND CONFIDENTIAL
This information on this document is the property of Bharat Heavy Electricals Limited
It must not be used directly or indirectly in any way detrimental to the interest

6.25. Bidder shall be responsible designing cyber security architecture for connecting to existing DCS. This will include providing modbus aware multi-port hardware firewalls for each unit, for communication with each DCS. Further, latest antivirus software with IPS, shall be provided for all workstations.

6.26. User level security:

6.26.1. The software shall support advanced security methods to provide protection against unauthorized access, disclosure, modification, and use. The Contractor shall describe the security provided by the software for user login and roles.

6.26.2. The application shall provide capabilities for user creation, deletion, lockout, login and password reset facilities.

6.26.3. The software shall allow tracking of all user access to the applications.

6.27. Improvement in Existing Control Schemes

6.27.1. The improvements in the existing control schemes shall be submitted for Employer's review after the SAT and implemented before the start of the six month performance test. Further, after implementation of these improvements, the Contractor shall also tune the existing control loops for better control loop performance during the stipulated load ranges.

6.28. Location: The APC equipment i.e. servers, workstations, controller along with the furniture shall be located in the CCR/CER of respective Units.

6.29. Remote connectivity: Bidder shall provide the necessary hardware & software required for connecting the APC system to Bidder's remote service centre, through which the diagnostics & fault analysis of the APC system can be carried out. In no case tuning of the model is allowed from remote, when APC is in ON mode. The method of connection shall be as per Bidder's standard practice using a firewall, subject to employer's approval during detailed engineering. Virtual Private networks (VPN) technology shall be used for data integrity and confidentiality. However, it is preferred to have the connection through a single point in the APC system. Further, this access shall be strictly under request control & record of such access shall be made available to the Employer's designated personnel. The fixed charges & running cost till warranty period shall be included in the Quoted Price. The running cost thereafter shall be included in the AMC price.

6.30. The software shall be suitable for life time of the plant.

6.31. All the hardware like server/workstations/controller, protocol converters as required for meeting the functional requirement of this specifications, shall be provided by the Contractor.

6.32. Bidder shall include a detailed BOM (hardware and software) of the proposed APC solution in the bid.

6.33. Contractor shall depute experienced personnel for the commissioning of the APC. The details of the proposed engineers along with their experience data shall be included in the bid. Bidder shall propose the same personnel who had executed the APC in the reference project, if the personnel is on the payrolls of the Bidder or the Bidder's associate.

Any request for substitution by new engineer during the execution of the project shall be subject to Employer's approval and upon submission of proper justification document by the Contractor.



**SPECIFICATION FOR ADVANCE
PROCESS CONTROL
PACKAGES**

PS4182060

Rev 00

Page 10 of 22

7.0 Work Schedule:

SI No	Activity	Activity Target (in no. of Months from post award)
1.	Kick off meeting at site identifying the phases of project along with the units, identification of tag list with KKS/address in existing as built logics required in APC, familiarization with existing controls & operation philosophy of stage-I & stage-II. Modbus prototype communication test in C&I Lab procontrol/maxDNA/Ovation with test hardware.	0.5
2.	Supply: Supply of complete hardware & software for first Unit	1
3.	Installation: Installation of software and interface testing for first unit	1.5
4.	Commissioning: Commissioning of the System in first Unit	2.5
5.	Training of Employers employees phase-I	3
6.	SAT(Site acceptance testing)for performance Testing: Performance Testing of System in first Unit	5
7.	For Second, third and fourth Unit: Phase wise installation, commissioning and SAT for performance testing in other three units	12
8.	Continuous running performance testing of system	15
9.	Training of Employers employees Phase-II	After completion of Installation of the System in each unit Of each stage.
10.	Completion of facilities	16
11.	Final Document & handover of the system to the employer	18

COPYRIGHT AND CONFIDENTIAL
This information on this document is the property of Bharat Heavy Electricals Limited
It must not be used directly or indirectly in any way detrimental to the interest



SPECIFICATION FOR ADVANCE PROCESS CONTROL PACKAGES

PS4182060

Rev 00

Page 11 of 22

8.0 SAT (Site Acceptance Test) for Performance Testing:

Site acceptance test shall be conducted for evaluating the performance of the APC software.

8.1. Site Acceptance Testing Setup: The SAT shall be done after completion of commissioning of the software (including interface testing, checking of fail-safe implementation etc).

8.2. In order to measure the performance of APC software, SAT would be conducted by comparing performance between APC Off and APC On scenarios.

8.3. Period of APC OFF and APC ON would be as per the details given in the table below, maintaining similar time of the day, to the best possible extent.

8.4. SAT of each of the APC solutions shall be done in the order indicated in the table.

8.5. As indicated above, implementation of improvements in the existing control schemes for min. stable load reduction as well as for enhancing the objectives of APC, shall be done after completion of SAT of all other APC software. Accordingly, SAT of the same shall be done subsequently.

8.6. In case vendor proposes to utilize their software for baselining and APC ON/OFF test calculations, the same shall be subject to employer's approval.

8.7. In case, it is required to change historian settings in existing DCS to archive required inputs/outputs/results of APC, the same shall be mutually agreed and accordingly shall be implemented by Employer.

8.8. In case of soot blowing, like all other tests, system shall be in closed loop during APC ON. However, if the plant decides to keep the sootblowing on advisory instead of closed loop, the same shall be tested in this mode; however all advisories shall be followed during the test period.

8.9. Contractor to also demonstrate the Combustion optimization APC software capability of reducing NOx. However, it will be reverted back to heat rate objective after demonstration.

8.10. Suitable precautions to be taken to ensure that there is no equipment/unit outage due to the conductance of the SAT.

8.11. In case during any test, any unforeseen condition arises in the Unit leading to change in test scenario, then the test can be repeated, subject to Employer's approval.

8.12. In case, the contractor is not able to achieve the performance figures during any test, without any reason attributed to the Employer, contractor can request for re-conductance of the test. However, this reconductance shall be subject to Employer's approval.

8.13. CPG (Contract Performance Guarantee) shall be released if the Contractor achieves the minimum improvement figure as indicated in Payment terms at clause 10.0 for SH/RH temperature excursion reduction, Faster load ramp up/ramp down, Combustion optimization and Soot blowing optimization.

8.14. Following prerequisites to be considered during the testing period to ensure similar operating conditions between APC ON duration and APC OFF duration.

8.14.1. Load conditions of the unit would be similar and RGMO (Restricted governing mode of operation) would be kept disabled.

8.14.2. Coal quality to be kept consistent. Coal sample to be taken during each of the test period. Coal parameters (measured on coal flow) to be within 5% variation during the period.

8.14.3. Mill combination and other auxiliaries to be maintained same during the test period.

8.14.4. All the loops shall be in Auto and no manual adjustment during the test period.

8.14.5. All set-point/bias adjustment would be in the range of acceptable limits finalized during design/engineering, not exceeding 10% of the operator provided set-points.

8.14.6. Ambient conditions must be similar. i.e. ambient temperature within ± 2 Deg C and relative humidity within $\pm 5\%$.

8.14.7. For Soot Blowing optimization test, specific coal [i.e. coal consumption (t/hr)/ load (mw)] variation of $\pm 5\%$ shall be considered as similar operating condition.

COPYRIGHT AND CONFIDENTIAL
This information on this document is the property of Bharat Heavy Electricals Limited
It must not be used directly or indirectly in any way detrimental to the interest



SPECIFICATION FOR ADVANCE PROCESS CONTROL PACKAGES

PS4182060

Rev 00

Page 12 of 22

8.14.8. If variation in above parameters is higher than the limits stated above, then the test can be re conducted.

8.15. In regard to any dispute arising during the testing, the decision of Employer's test team shall be final and binding on the Contractor.

8.16. The table below lists the different test scenarios for each objective of APC solution. In each of this test scenario, in one iteration APC software will be 'kept off' and in other iteration, in the same scenario, APC software will be 'made on', to capture performance parameters, as listed in table below. During APC 'on' test, there should not be deterioration of existing controls.

APC Solution	Test Scenario			To be Measured	No. of test for each range of scenario / Duration of each test
	Load (Steady State / Dynamic)	Load Range Scenarios (TMCR)	Other scenarios		
SH/RH Temperature Excursion Reduction	Steady State	1) Range 1 – 100% (+/-5% Loading factor 2) Range 2 – 80% (+/-5%) Loading factor 3) Range 3 – 55%-60% loading factor	During Soot Blowing (as per Current practice), During Mill Changeover and other conditions As decided during detail engineering.	Standard Deviation of SH Steam Temp (LHS & RHS) and standard deviation of RH Steam Temp (LHS & RHS), from respective set-point, for every 1 sec sample, keeping other parameters, as per Table A below, within limits	3 tests / 4 hr.
Faster Ramp Up/Ramp Down	Dynamic	1) Range 1-100% to 70% loading factor and vice versa 2) Range 2-70% to 55%	SH/RH temp Excursion Reduction APC Software to be Kept ON	Standard Deviation of Throttle Pressure, SH Steam Temp (LHS & RHS)	3 tests / As required, Max. 2 hours.

COPYRIGHT AND CONFIDENTIAL
 This information on this document is the property of Bharat Heavy Electricals Limited
 It must not be used directly or indirectly in any way detrimental to the interest



**SPECIFICATION FOR ADVANCE
PROCESS CONTROL
PACKAGES**

PS4182060

Rev 00

Page 13 of 22

COPYRIGHT AND CONFIDENTIAL
This information on this document is the property of Bharat Heavy Electricals Limited
It must not be used directly or indirectly in any way detrimental to the interest

		loading factor and vice versa	during 'APC ON' of this test.	And Steam Temp (LHS & RHS), from respective set-point, for every 1 seconds sample, keeping other parameters, as per Table B below, within limits.	
Combustion Optimization	Steady State	1) Range 1 - 100% (+/-5%) loading factor 2) Range 2 - 80% (+/-5%) loading factor 3) Range 3 - 55%-60% loading factor	- SH/RH temp. Excursion reduction and Faster Ramp up/Ramp down APC software to Be kept ON during 'APC ON' of this test. - In Range 1, test would be conducted at 3 (three) different coal qualities.	Heat Rate using delta heat rate method as per parameter and weights given by below table. Data Sampling at every 1 second.	3 tests / 4 hr.
Soot blowing Optimization	Steady State	Any load range. (As per Scheduled Generation)	SH/RH temp. Excursion reduction and Faster Ramp up/Ramp down APC software to Be kept ON during 'APC ON' of this test.	Heat Rate using delta heat rate method as per parameter and weights given by below table. Data Sampling at every 1 second.	2 tests / 8 days



**SPECIFICATION FOR ADVANCE
PROCESS CONTROL
PACKAGES**

PS4182060

Rev 00

Page 14 of 22

Reduce Min stable load	Steady State	50% loading factor	‘APC OFF’ test is not Applicable. All APC software to be kept ON.	Min. load at which stable control is available ie. control loops, as listed below, are functioning in auto without oil support while maintaining flame stability, keeping other parameters, as per Table C below, within limits.	Stable load For 1 hrs.
------------------------	--------------	--------------------	--	--	------------------------

COPYRIGHT AND CONFIDENTIAL
This information on this document is the property of Bharat Heavy Electricals Limited
It must not be used directly or indirectly in any way detrimental to the interest

Table A – Parameter deviation limits to be maintained during SH/RH temperature excursion reduction test

Metal Temp
(Deg C)

SH & RH,
Tube metal temp. and Header metal temp, not greater than specified operating limits for more than 10 secs.



**SPECIFICATION FOR ADVANCE
PROCESS CONTROL
PACKAGES**

PS4182060

Rev 00

Page 15 of 22

Table B – Parameter deviation limits to be maintained during Faster Ramp up/Ramp down test

Load Change (% of MCR Per min.)	FG O2 Deviation (% O2)	Furnace Pressure Deviation (mmwcl)	Drum Level Deviation (mmwcl)	Metal Temp (Deg C)
3%	+0.6/-0.4	±12.0	±25.0	SH & RH, Tube metal temp. and Header metal temp, not greater than specified operating limits for more than 10 secs.
5%	+0.8/-0.4	±12.0	±30.0	
10%	+1.0/-0.5	±15.0	±50.0	

Table C – Parameter deviation limits to be maintained during Min Stable load test

Throttle Pressure Deviation (Kg/Cm2)	SH & RH Temperature (Deg C)	Furnace Pressure Deviation (mmwcl)	Drum Level Deviation (mmwcl)	Flue Gas (% O2)
±2.0	±5.0	±8.0	±15.0	±0.4

For each APC software solution except reduce Min stable load, Improvement calculation shall be as follows:

1. (A) For SH/RH Temperature Excursion Reduction and Faster Ramp up/Ramp Down:

Improvement of individual test scenario: Improvement of each test scenario will be calculated by taking difference between 'APC On' and 'APC off' value of measured parameter, for that scenario. For, more than one parameter, individual value of measured parameter shall be added to arrive at total value of measured parameters, for that scenario. Improvement shall mean reduction in standard deviation.

E.g. Calculation for SH/RH temperature excursion reduction, in any given test scenario. During 'APC OFF'.

Value of Standard deviation in 'APC OFF' = (Std deviation in SH Steam Temp LHS + Std deviation in SH Steam Temp RHS + Std deviation in RH Steam Temp LHS + Std deviation in RH Steam Temp RHS) during that test scenario in 'APC OFF'

During 'APC ON'

Value of Standard deviation in 'APC ON' = (Std deviation in SH Steam Temp LHS + Std deviation in SH Steam Temp RHS + Std deviation in RH Steam Temp LHS + Std deviation in RH Steam Temp RHS) during that test scenario in 'APC ON'

COPYRIGHT AND CONFIDENTIAL

This information on this document is the property of Bharat Heavy Electricals Limited
It must not be used directly or indirectly in any way detrimental to the interest



SPECIFICATION FOR ADVANCE PROCESS CONTROL PACKAGES

PS4182060

Rev 00

Page 16 of 22

Improvement of that test scenario = Value of Standard Deviation in 'APC OFF' - Value of Standard Deviation in 'APC ON'

(B) For Combustion Optimization and Soot Blowing Optimization:

Improvement in Heat rate using delta heat rate method shall be calculated as below for 'APC ON' and 'APC OFF' of each of the test scenarios. Improvement shall mean reduction in heat rate.

The delta heat rate for evaluating Combustion optimization will be as per below formula:

%Delta HR for Combustion Optimization=

$$A1+ (MST_{APC\ ON} - MST_{APC\ OFF}) +$$

$$A2+ (RHT_{APC\ ON} - RHT_{APC\ OFF}) +$$

$$A3+ (SH\ spray_{\%APC\ ON} - SH\ spray_{\%APC\ OFF}) +$$

$$A4+ (RH\ spray_{\%APC\ ON} - RH\ spray_{\%APC\ OFF}) +$$

$$A5+ (O2_{\%APC\ ON} - O2_{\%APC\ OFF}) +$$

$$A6+ (FGTAH_{outlet_{APC\ ON}} - FGTAH_{outlet_{APC\ OFF}}) +$$

$$A7+ (Unburnt\ C\% \text{ in Fly Ash}_{APC\ ON} - Unburnt\ C\% \text{ in Fly Ash}_{APC\ OFF}) +$$

$$A8+ (Unburnt\ C\% \text{ in Bottom Ash}_{APC\ ON} - Unburnt\ C\% \text{ in Bottom Ash}_{APC\ OFF})$$

The delta heat rate for evaluating Soot blowing optimization will be as per below formula:

%Delta HR for Soot blowing =

$$A1+ (MST_{APC\ ON} - MST_{APC\ OFF}) +$$

$$A2+ (RHT_{APC\ ON} - RHT_{APC\ OFF}) +$$

$$A3+ (SH\ spray_{\%APC\ ON} - SH\ spray_{\%APC\ OFF}) +$$

$$A4+ (RH\ spray_{\%APC\ ON} - RH\ spray_{\%APC\ OFF}) +$$

$$A5+ (O2_{\%APC\ ON} - O2_{\%APC\ OFF}) +$$

$$A6+ (FGTAH_{outlet_{APC\ ON}} - FGTAH_{outlet_{APC\ OFF}}) +$$

$$A7+ (Unburnt\ C\% \text{ in Fly Ash}_{APC\ ON} - Unburnt\ C\% \text{ in Fly Ash}_{APC\ OFF}) +$$

$$A8+ (Unburnt\ C\% \text{ in Bottom Ash}_{APC\ ON} - Unburnt\ C\% \text{ in Bottom Ash}_{APC\ OFF}) +$$

$$A9+ (SBflow_{APC\ ON} - SBflow_{APC\ OFF})$$

Note: Parameter value during 'APC ON', 'APC OFF' shall be average of value for test duration at 1 second sample rate.

e.g. $MST_{APC\ ON}$ = Average (MST during 'APC ON' for test duration at 1 sec sampling rate)



**SPECIFICATION FOR ADVANCE
PROCESS CONTROL
PACKAGES**

PS4182060

Rev 00

Page 17 of 22

The weights of parameters A1 to A9 will be as per below table:

Coefficient	Parameter	Weight	Remarks
A1.	Main Steam Temperature	-0.029%	%HR/1degC
A2.	Reheat Temperature	-0.026%	%HR/1decC
A3.	Superheat Spray% 1	0.025%	%HR/1% spray
A4.	Reheat Spray% 1	0.22%	%HR/1% spray
A5.	Flue Gas O2% at Eco Outlet	0.25%	%HR/1% O2
A6.	Flue Gas Temperature at AH outlet	0.05%	%HR/1degC
A7.	Unburnt C% in Fly Ash2	0.4%	%HR/1%
A8.	Unburnt C% in Bottom Ash2	0.1%	%HR/1%
A9.	Soot Blowing Steam Flow	0.067%	%HR/1T/hr.

1. % spray = Spray flow as % of rated MS flow
2. Bottom ash and fly ash samples will be analyzed for unburnt carbon % by weight as per ASTM D 7348-13.

2. **Net improvement:** Net improvement of an APC software solution, will be calculated by taking average of all the improvement value (positive/negative) achieved for individual test scenario, calculated as per above clause.

All improvement figures to be rounded to two decimal places. i.e 1.555 = 1.55, 1.556=1.56.

9.0 Continuous Performance Test:

After the conductance of SAT with APC ON/OFF methodology, a continuous run of the system with APC permanently ON will be conducted for a period of six months for each unit to ascertain that heat rate benefits due to APC implementation are being consistently maintained.

In order to calculate the same, the APC ON/OFF test shall be conducted, with all APC software kept ON, every 15 days for a period of six months. This test shall be done at 100% (+/- 5%) loading factor for a period of 4 hours. Delta Heat rate methodology, as given in this document shall be utilized for calculating the heat rate improvements. Average results of all these tests shall be taken to arrive at average heat rate improvement of continuous performance test. In case, the heat rate improvement of continuous performance test is lesser than that achieved during SAT, then the contractor shall take necessary corrective measure to achieve same level of performance as achieved in SAT.

COPYRIGHT AND CONFIDENTIAL
 This information on this document is the property of Bharat Heavy Electricals Limited
 It must not be used directly or indirectly in any way detrimental to the interest



**SPECIFICATION FOR ADVANCE
PROCESS CONTROL
PACKAGES**

PS4182060

Rev 00

Page 18 of 22

The average heat rate benefit achieved with APC implementation during continuous performance test shall be documented. If the same results in heat rate improvement of more than 0.5% (as per above procedure), a letter of appreciation from the Station Management with the achieved heat rate benefit shall be given to the Contractor.

It may be noted that NTPC's decision w.r.t achieved heat rate benefit shall be final and binding on the Contractor. No representation whatsoever from the Contractor in this regard shall be entertained. Further, no monetary reward/incentive or compensation shall be given to the Contractor, for achieving the heat rate benefit over and above 0.5% or achieving better improvement in parameter standard deviation over the value stipulated in this contract.

10.0 Break-up of SAT:

S No	Item	Payment Percentage	Remarks
1	Initial Advance	5%	
2	Kick off Meeting at site and finalization of Required documents and procedures (Approval of Employer)	5%	
3	Material Receipt to Site	5%	To be split unit wise
4	SAT	80%	To be split unit wise
A	SH/RH Temperature Excursion Reduction	25%	To be split unit wise & Distribution as per SNo A of Below table
B	Faster load Ramp up/Ramp Down	10%	To be split unit wise & Distribution as per SNo B of Below table
C1	Combustion Optimization	40%	To be split unit wise & Distribution as per SNo C of Below table
C2	Soot Blowing Optimization		To be split unit wise & Distribution as per SNo C of Below table
D	Reduce Min. stable load	5%	To be split unit wise & Distribution as per SNo D of below table
5	COF	5%	To be split unit wise

COPYRIGHT AND CONFIDENTIAL
This information on this document is the property of Bharat Heavy Electricals Limited
It must not be used directly or indirectly in any way detrimental to the interest



**SPECIFICATION FOR ADVANCE
PROCESS CONTROL
PACKAGES**

PS4182060

Rev 00

Page 19 of 22

Payment terms based on milestones

SNo	Performance Milestone	Milestone
A	Net Improvement in Standard Deviation of SH & RH steam temperature excursion (as per clause 8.16 above)	<p>1. For, Net Improvement in Standard Deviation of SH & RH steam temperature excursion between 10% to 50%, payment shall be in the range of 5% to 25% of PO price (incl tax).</p> <p>Example: Net Improvement = 30%. Payment (intl. Tax) is calculated as follows: $5\% + \{[(20\%-5\%) / (50\%-10\%)] * (30\%-10\%)\}$</p> <p>2. For Net Improvement in Standard Deviation of SH & RH steam temperature excursion of 10% ; payment of 5% of PO price (incl tax).</p> <p>3. For Net Improvement in Standard Deviation of SH & RH steam temperature excursion of 10% ; no payment</p>
B	Net Improvement in Standard Deviation Of Throttle Pressure, SH and RH steam temperature excursion (as per clause 8.16 above)	<p>1. For, Net Improvement in Standard Deviation of Throttle Pressure, SH & RH steam temperature excursion between 10% to 50%, payment shall be in the range of 2% to 10% of PO price (incl tax).</p> <p>Example: Net Improvement = 30%, Payment (intl. Tax) is calculated as follows: $2\% + \{[(10\%-2\%) / (50\%-10\%)] * (30\%-10\%)\}$</p> <p>2. For Net Improvement in Standard Deviation of Throttle Pressure, SH & RH steam temperature excursion of 10% ; payment of 2% of PO price (incl tax).</p> <p>3. For Net Improvement in Standard Deviation of Throttle Pressure, SH & RH steam temperature excursion of <10%; no payment.</p>
C	Net Improvement in Unit Heat Rate by Combustion Optimization and Soot blowing optimization (Summation of results of SAT of each of this APC solution)	<p>1. For, Net Improvement in Unit Heat Rate between 0.1% to 0.5%, payment shall be in the range of 8% to 40% of PO price (incl tax).</p> <p>Example: Heat Rate Improvement = 0.15%. Payment (intl. Tax) is calculated as follows: $8\% + \{[(40\%-8\%) / (0.5\%-0.1\%)] * (0.15\%-0.1\%)\}$</p> <p>2. For Net Improvement in Unit Heat Rate of 0.1% ; Payment of 8% of PO price (incl. Tax).</p>

COPYRIGHT AND CONFIDENTIAL
 This information on this document is the property of Bharat Heavy Electricals Limited
 It must not be used directly or indirectly in any way detrimental to the interest



SPECIFICATION FOR ADVANCE PROCESS CONTROL PACKAGES

PS4182060

Rev 00

Page 20 of 22

	(as per clause 8.16 above)	3. For Net Improvement in Unit Heat Rate of <0.1% ; no payment.
D	Improvement in Stable Min. Load (as per clause 8.16 above)	1. For Achieving Stable Min load of 50% loading factor, payment of 5% of PO price (incl. Tax)

11.0 Warranty and AMC:

Comprehensive warranty of complete APC system (hardware & software) for a period of one(1) year from the completion of the SAT shall be provided. The warranty period for each unit shall start after completion of SAT of that unit. This shall include services every quarter for tuning of the APC software including the models. The routine and preventive maintenance during the period of warranty shall also be carried out by the Contractor. This warranty shall include repair, replacement or correction of identified software or hardware discrepancies at no cost to the employer. Bidder shall depute adequate experienced personnel as and when required during the warranty period to ensure 99% system availability.

Comprehensive on-site hardware/software Annual Maintenance Contract (AMC) shall be provided for a period of three(3) years after the completion of comprehensive warranty period. AMC shall be applicable after expiry of the warranty period of the respective unit. The comprehensive AMC shall cover total maintenance of all hardware & software coming under the scope of Bidder and shall include free repair/replacement of all peripherals/cables/components, etc. correction of software problems and supply of expendable items. This shall also include services every quarter for tuning of the APC software including the models. The Bidder shall ensure 99% availability of the system with AMC. For the purpose, contractor may maintain adequate no. of staff at site as per his own assessment if considered necessary to ensure availability. However, the Contractor should depute APC expert every six months for a period of min. three days during AMC in order to check the proper and effective functioning of the system.

As indicated in the Scope of Work, all software updates, include operating system patches, antivirus software/signatures, firewall software/signatures, shall be provided during warranty period as well as AMC period without any additional cost implication to End Customer.

Bidder shall include details of the agency providing this support in the bid. This support can be from remote location as per the standard practice of the Bidder. Bidder shall include details of the setup for remote support in the bid. All hardware/software for this purpose shall be included in Bidder's scope.

12.0 Training:

12.1 Developer/ Administrator level training: The Contractor shall provide detailed training to Employer's eight(8) engineers at the works of the APC technology provider, for a period of one week, which will ensure complete self sufficiency in implementing, operating, troubleshooting and maintaining the complete APC solution. This training shall be conducted by personnel well qualified and having in-depth knowledge of the offered technology and having experience of implementation of the offered technology. At the end of this training,

COPYRIGHT AND CONFIDENTIAL
 This information on this document is the property of Bharat Heavy Electricals Limited
 It must not be used directly or indirectly in any way detrimental to the interest



SPECIFICATION FOR ADVANCE PROCESS CONTROL PACKAGES

PS4182060

Rev 00

Page 21 of 22

the participants shall be able to tune the settings of the APC software in order to account for plant/equipment characteristics change or modification in the objectives of the APC solution. The details of the developer/ administrator level training such as course contents, location, time schedule etc shall be included in the bid. The above training shall be split into batches (min. two batches) to facilitate smooth technology absorption.

12.2 User level training: The Contractor shall provide user level training to fifty(50) no.s of Employer's operation personnel at site for 2-3 working days. The training shall be held in two batches, one batch for each stage. This training need to be conducted before the commissioning activity of the APC of the respective stage.

12.3 APC Familiarization: The Contractor shall provide a one day familiarization on the offered APC solution at site during the kickoff meeting. There shall be no limitation on the number of participants for this familiarization programme. The intended audience will include station management and RED.

Training Material shall be provided to each of the participants of the above courses.

13.0 Documentation:

Bidder to provide all standard product manual, O&M manual etc. for all the components of the APC solutions.

Bidder to submit Function Design specification, of system, hardware, system software and any third party systems including but not limited to interfacing with DCS, remote connectivity ,datasheets of all hardware based on the discussion during kick off meeting for review of Employer. Bidder to revise the document incorporating changes mentioned by Employer and submit the FDS before supply of the equipment to site. Bidder to submit detailed testing procedure for each module of APC as per site configuration for approval of EIC. Based on their comments bidder to submit revised testing procedure. It is the responsibility of bidder to get the testing procedure approved well before start of performance testing. Final documentation must include the procedures like system restoration, license restoration, taking backup, trouble shooting of the system.

COPYRIGHT AND CONFIDENTIAL
This information on this document is the property of Bharat Heavy Electricals Limited
It must not be used directly or indirectly in any way detrimental to the interest



SPECIFICATION FOR ADVANCE PROCESS CONTROL PACKAGES

PS4182060

Rev 00

Page 22 of 22

Annexure-I

Details of Existing DCS & Interfacing with APC:

For Stage-I units, PROCONTROL P13/42 system has been supplied by BHEL,EDN for SG, TG as well as BOP C&I. The pro control DDCMIS through interface module 70BK08b for each of 4 IPBs shall be interfaced for bi-directional communication with APC.

For Stage-II units, Ovation 3.2 has been supplied by Emerson process management for BOP C&I. maxDNA 4.5 has been supplied by BHEL-EDN for SG integral &TG integral systems. modbus of Ovation through IP switch and modbus over maxNET through EB block of maxDNA shall be interfaced for bi directional modbus communication with APC.

Existing Control Loops:

The following control loops are part of existing control system:

O2 Set point, WB/Furnace DP, Furnace Pressure, FD Fan Balance, ID Fan Balance, PA Fan Balance, Aux Air Flow/Dampers, Fuel Air Dampers, Burner Tilt Position, Mill Speed (Feeder Speed), Primary Air Flow, Secondary Air Flow, Mill (Air Flow), Fuel Air Temperature, Drum Level Control, FW Flow, SCAPH Temp Control, SH steam temp. Control, RH steam temp. Control, D/A level control, D/A Pr control, CEP Hdr pressure control, Fuel master, Boiler master, CMC.

COPYRIGHT AND CONFIDENTIAL
This information on this document is the property of Bharat Heavy Electricals Limited
It must not be used directly or indirectly in any way detrimental to the interest



NTPC Limited
(A Government of India Enterprise)
EOC Noida Office
INVITATION FOR BIDS (IFB)
FOR

#Advanced Process Control-(APC) Package for SIMHADRI Stg-I (2 X 500 MW) & Stg-II(2X500 MW) for design, testing, supply, installation, commissioning of APC (Advanced Process Control) software#.
(International Competitive Bidding)

IFB No: 40086783

Date:

1.0 NTPC invites on-line bids from eligible Bidders for aforesaid package, as per the scope of work briefly mentioned hereinafter:

2.0 Brief Details

IFB No.	40086783
IFB Date	03.04.2018
Document Sale Commencement Date & Time	03.04.2018 10:00:00
Document Sale Close Date & Time	10.04.2018 17:30:00
Source of IFB/NIT	EOC Noida Office
Contract Classification	Equipment Supply & Erection
Last Date and Time for Bid submission	01.05.2018 14:30:00
Technical Opening Date & Time	01.05.2018 15:00:00
Bid Opening Date & Time	08.05.2018 15:00:00
Cost of Bidding Documents in INR	22,500.00
EMD in INR	2725000.00
Pre-Bid Conference Date & Time (if any)	17.04.2018 11:00:00
Last Query Date (if any)	17.04.2018
EMD in USD	41700.00
Cost of Bidding Documents in USD for foreign bidder	500.00
Funding Source	Internal Resources

3.0 Bid Security and Integrity Pact (if applicable) shall be submitted in a sealed envelope separately offline/online by the stipulated bid submission closing date and time at the address given below. Any bid without an acceptable Bid Security and Integrity Pact (if applicable) shall be treated as non-responsive by the employer and shall not be opened.

4.0 A complete set of Bidding Documents may be downloaded by any interested Bidder on payment (non-refundable) of the cost of the documents as mentioned above in the form of a crossed account Payee demand draft in favour of NTPC Ltd., Payable at New Delhi or directly through the payment gateway at our SRM Site (<https://etender.ntpclakshya.co.in/sap/bc/gui/sap/its/bbpstart>). For logging on to the SRM Site, the bidder would require vendor code and SRM user id and password which can be obtained by submitting a questionnaire available at our SRM site as well as at NTPC tender site (www.ntpctender.com). First time users not allotted any vendor code are required to approach NTPC at least three working days prior to Document Sale Close date alongwith duly filled in questionnaire for issue of vendor code and SRM user id/password.

5.0 Brief Scope of Work & other specific detail

#Advanced Process Control-(APC) Package for SIMHADRI Stg-I (2 X 500 MW) & Stg-II(2X500 MW) for design, testing, supply, installation, commissioning of APC (Advanced Process Control) software#.

6.0 Prospective bidders from U.P. State are compulsorily required to provide TIN number at the time of purchase of bidding documents.

7.0 Qualifying Requirements for Bidders:

7.1.0 Technical Criteria:

7.1.1 Route-1 (For Bidder)

The Bidder should meet (A) and (B) below.

7.1.1 (A) The Bidder should have Engineered, Manufactured, Supplied, Erected/Supervised Erection & Commissioned/Supervised Commissioning of Distributed Digital Control, Monitoring & Information system (DDCMIS) / Distributed Control System (DCS), which should have been in successful operation in at least one (1) unit of a coal fired station having unit rating of 200 MW or above for a period of not less than one (1) year prior to the date of bid opening.

The DDCMIS/DCS above should necessarily include as a minimum,

- a. Modulating control for Steam-Generator (SG)
- b. Modulating control for Feedwater/ Condensate cycle (SG)
- c. Binary control of the auxiliaries for Steam-Generator (SG)
- d. Binary control of the auxiliaries for Turbine-Generator (TG)

The Bidder or its group company should have an established DDCMIS hardware and software service centre in India working for at least five (5) years prior to the date of bid opening.

7.1.1 (B) The Bidder should have Supplied and Commissioned Advanced Process Control software for the following:

(B1) Combustion optimization, in closed loop which should have been in successful operation in at least one (1) unit of pulverized coal fired station having unit rating of 200 MW or above, for a period of not less than one (1) year prior to the date of bid opening.

(B2) Soot Blowing Optimization, in closed loop which should have been in successful operation in at least one (1) unit of pulverized coal fired station having unit rating of 200 MW or above, for a period of not less than one (1) year prior to the date of bid opening.

(B3) Faster load Ramp-up/Ramp-down, in closed loop which should have been in successful operation in at least one (1) unit of pulverized coal fired station having unit rating of 200 MW or above, for a period of not less than one (1) year prior to the date of bid opening.

OR

SH/RH Temperature Excursion Reduction, in closed loop which should have been in successful operation in at least one (1) unit of pulverized coal fired station having unit rating of 200 MW or above, for a period of not less than one (1) year prior to the date of bid opening.

7.1.2 Route-2 (For Bidder with Collaborator(s)/Associate(s))

The Bidder, who meets the requirement at 7.1.1 (A) above but does not meet one or more of the requirements at 7.1.1 (B) above (i.e. B1 to B3), can also participate provided it associates with APC supplier/suppliers who meet the requirement(s) at 7.1.1 (B) above (i.e. B1 or B2 or B3 or any combination thereof) which the Bidder does not meet, so that complete requirements of 7.1.1 (A) and 7.1.1 (B) (i.e. B1, B2 & B3) above are met by the Bidder along with its Associate(s).

In such a case, the Bidder should furnish along with its bid a Deed of Joint Undertaking (DJU), jointly executed by it along with each of its Collaborator(s)/Associate(s) for full responsibility of the performance of the respective Advanced Process Control software as per format enclosed with the bidding document in which the Collaborator(s)/Associate(s) and the bidder shall be jointly & severally liable to the Employer to perform all contractual obligations for the scope of work for which the Collaborator(s)/Associate(s) is/are responsible. This Deed of Joint Undertaking should be submitted along with the Bid, failing which the Bidder shall be disqualified and its bid shall be rejected. In case of award, the Collaborator(s)/Associate(s) shall be required to furnish an on-demand Bank Guarantee as per the format enclosed with the bidding documents for a value equal to 5% (five percent) of the total contract price in addition to the Contract Performance Security to be furnished by the bidder.

Notes:

1. Advanced Process Control (APC) shall mean the set of techniques which use a multiple input multiple output predictive model for improving the existing performance of the control loops w.r.t the desired objective (i.e. efficiency improvement or emissions reduction etc). The model can be first principles based, empirical or ANN (artificial neural network) or fuzzy logic based.
2. Combustion Optimization shall include optimizing the flue gas O₂ trim, air registers, and feeder rate bias in order to improve heat rate/ reduce NO_x.
3. Faster load ramp up/ ramp down shall mean using APC for main steam pressure control loop.
4. SH/RH temperature excursion reduction shall mean using APC for SH/RH spray control loop.
5. Wherever the term #coal fired# is appearing above, #coal# shall be deemed to also include bituminous coal/ sub-bituminous coal/

brown coal/ lignite.

6. The reference plant for 7.1.1 (B) above (i.e. B1, B2 and B3) need not be same.

7. The Advanced Process Control software offered for this package should either be same, as referred at 7.1.1 (B) above (i.e. B1, B2 and B3), or be newer versions or upgrades of the same product or a product whose name has been changed after version/product upgrade.

8. Successful operation at 7.1.1 (B) (B1) to 7.1.1 (B) (B3) above shall mean that the End-user of the reference plant achieved the desired benefit from the respective Advanced Process Control software.

7.2.0 Financial criteria of Bidder

7.2.0 (a) The average annual turnover of the Bidder, in the preceding three (3) financial years as on the date of bid opening, should not be less than Rs. 10.7 Crores (Rupees Ten Crores and Seventy Lacs Only) or in equivalent foreign currency.

In case the bidder does not satisfy the average annual turnover criteria, stipulated above on its own, its Holding Company would be required to meet the stipulated turnover requirements as above, provided that the net worth of such Holding Company as on the last day of the preceding financial year is at least equal to or more than the paid-up share capital of the Holding Company. In such an event, the bidder would be required to furnish along with its bid, a Letter of Undertaking from the Holding Company, supported by the Holding Company's Board Resolution as per the format enclosed in the bid documents, pledging unconditional and irrevocable financial support for the execution of the Contract by the Bidder in case of award.

7.2.0 (b) The Net Worth of the bidder as on the last day of the preceding financial year should not be less than 100% (hundred percent) of its paid-up share capital. In case the Bidder does not satisfy the Net Worth criteria on its own, it can meet the requirement of Net worth based on the strength of its Subsidiary (ies) and/or Holding Company and/or Subsidiaries of its Holding companies wherever applicable. In such a case, however, the Net worth of the Bidder and its subsidiary (ies) and/or Holding Company and/or subsidiary (ies) of the Holding Company, in combined manner should not be less than 100% (hundred percent) of their total paid-up share capital. However individually, their Net worth should not be less than 75% (seventy five percent) of their respective paid-up share capitals.

Net worth in combined manner shall be calculated as follows:

Net worth (combined) = $(X1+X2+X3) / (Y1+Y2+Y3) \times 100$

Where X1, X2, X3 are individual Net worth which should not be less than 75% of the respective paid up share capitals and Y1, Y2, Y3 are individual paid up share capitals.

7.2.0 (c) In case the bidder is not able to furnish its audited financial statements on stand alone entity basis, the unaudited unconsolidated financial statements of the bidder can be considered acceptable provided the bidder further furnishes the following documents for substantiation of its qualification:

(i) Copies of the unaudited unconsolidated financial statements of the bidder along with copies of the audited consolidated financial statements of its Holding Company.

(ii) A Certificate from the CEO/CFO of the Holding Company, as per the format enclosed in the bidding documents, stating that the unaudited unconsolidated financial statements form part of the consolidated annual financial statements of the Holding Company.

In case where audited results for the last financial year as on the date of bid opening are not available, the financial results certified by a practicing Chartered Accountant shall be considered acceptable. In case, Bidder is not able to submit the certificate from a practicing Chartered Accountant certifying its financial parameters, the audited results for the three consecutive financial years preceding the last financial year shall be considered for evaluating the financial parameters. Further, a Certificate would be required from the CEO/CFO as per the format enclosed in the bid documents stating that the Financial results of the Company are under audit as on the date of bid opening and the Certificate from the practicing Chartered Accountant certifying the financial parameters is not available.

7.3.0 Financial Criteria of Collaborator(s)/Associate(s) of the Bidder

7.3.0 (a) The average annual turnover of the Collaborator/Associate, in the preceding three (3) financial years as on the date of bid opening, should not be less than the following for different Collaborator(s) / Associates(s) as applicable.

Collaborator(s) / Associates(s) Applicable clauses Required annual turnover in Crores Rupees or in equivalent foreign currency

APC Supplier 7.1.1 (B) B1 Rs. 4.3 Crores (Rupees Four Crores and Thirty Lacs Only)

APC Supplier 7.1.1 (B) B2 Rs. 4.3 Crores (Rupees Four Crores and Thirty Lacs Only)

APC Supplier 7.1.1 (B) B3 Rs. 2.7 Crores (Rupees Two Crores and Seventy Lacs Only)

APC Supplier 7.1.1 (B) B1 & 7.1.1 (B) B2 Rs. 4.3 Crores (Rupees Four Crores and Thirty Lacs Only)

APC Supplier 7.1.1 (B) B2 & 7.1.1 (B) B3 Rs. 7 Crores (Rupees Seven Crores Only)

APC Supplier 7.1.1 (B) B1 & 7.1.1 (B) B3 Rs. 7 Crores (Rupees Seven Crores Only)

APC Supplier 7.1.1 (B) B1, 7.1.1 (B) B2 & 7.1.1 (B) B3 Rs. 7 Crores (Rupees Seven Crores Only)

In case the Collaborator/Associate does not satisfy the average annual turnover criteria, stipulated above on its own, its Holding Company would be required to meet the stipulated turnover requirements as above, provided that the net worth of such Holding

Company as on the last day of the preceding financial year is at least equal to or more than the paid-up share capital of the Holding Company. In such an event, the Collaborator/Associate would be required to furnish along with its bid, a Letter of Undertaking from the Holding Company, supported by the Holding Company's Board Resolution as per the format enclosed in the bid documents, pledging unconditional and irrevocable financial support for the execution of the Contract by the Collaborator/Associate in case of award.

7.3.0 (b) The Net Worth of the Collaborator/Associate as on the last day of the preceding financial year should not be less than 100% (hundred percent) of its paid-up share capital. In case the Collaborator/Associate does not satisfy the Net Worth criteria on its own, it can meet the requirement of Net worth based on the strength of its Subsidiary(ies) and/or Holding Company and/or Subsidiaries of its Holding companies wherever applicable. In such a case, however, the Net worth of the Collaborator/Associate and its subsidiary(ies) and/or Holding Company and/or subsidiary (ies) of the Holding Company, in combined manner should not be less than 100% (hundred percent) of their total paid-up share capital. However individually, their Net worth should not be less than 75% (seventy five percent) of their respective paid-up share capitals.

Net worth in combined manner shall be calculated as follows:

Net worth (combined) = $(X1+X2+X3) / (Y1+Y2+Y3) \times 100$

Where X1, X2, X3 are individual Net worth which should not be less than 75% of the respective paid up share capitals and Y1, Y2, Y3 are individual paid up share capitals.

7.3.0 (c) In case the Collaborator/Associate is not able to furnish its audited financial statements on stand alone entity basis, the unaudited unconsolidated financial statements of the Collaborator/Associate can be considered acceptable provided the Collaborator/Associate further furnishes the following documents for substantiation of its qualification:

(i) Copies of the unaudited unconsolidated financial statements of the Collaborator/Associate along with copies of the audited consolidated financial statements of its Holding Company.

(ii) A Certificate from the CEO/CFO of the Holding Company, as per the format enclosed in the bidding documents, stating that the unaudited unconsolidated financial statements form part of the consolidated annual financial statements of the Holding Company.

In case where audited results for the last financial year as on the date of bid opening are not available, the financial results certified by a practicing Chartered Accountant shall be considered acceptable. In case, Collaborator/Associate is not able to submit the certificate from a practicing Chartered Accountant certifying its financial parameters, the audited results for the three consecutive financial years preceding the last financial year shall be considered for evaluating the financial parameters. Further, a Certificate would be required from the CEO/CFO as per the format enclosed in the bidding documents stating that the Financial results of the Company are under audit as on the date of bid opening and the Certificate from the practicing Chartered Accountant certifying the financial parameters is not available.

NOTES:

(i) Net worth means the sum total of the paid up share capital and free reserves. Free reserve means all reserves credited out of the profits and share premium account but does not include reserves credited out of the revaluation of the assets, write back of depreciation provision and amalgamation. Further any debit balance of Profit and Loss account and miscellaneous expenses to the extent not adjusted or written off, if any, shall be reduced from reserves and surplus.

(ii) Other income shall not be considered for arriving at annual turnover.

(iii) ##Holding Company# and #Subsidiary Company# shall have the meaning ascribed to them as per Companies Act of India.

(iv) For annual turnover indicated in foreign currency, the exchange rate as on seven (7) days prior to the date of bid opening shall be used.

8.0 Issuance of Bidding Documents to any bidder shall not construe that bidder is considered qualified.

9.0 NTPC reserves the right to reject any or all bids or cancel/withdraw the Invitation For Bids (IFB) for the subject package without assigning any reason whatsoever and in such case no bidder/intending bidder shall have any claim arising out of such action.

10.0 Address for Communication

Addl. General Manager (CM)
NTPC LTD., 6th Floor, EOC,
Plot no. A-8A, Sector 24
NOIDA(UP),India-201 301
0120- 4946625/2410477
Email ID: rckhorwal@ntpc.co.in

Or

DGM(CM)

NTPC LTD., 6th Floor, EOC,

Plot no. A-8A, Sector 24

NOIDA(UP),India-201 301

0120 - 4948624

Email ID:sandeepdatta@ntpc.co.in

Websites: <https://etender.ntpclakshya.co.in/sap/bc/gui/sap/its/bbpstart> or www.ntpc.co.in

*electronic tendering
e-procurement (SRM)*

*Volume-I
Section-I*

Instruction to Bidders .. "e" _ tendering



<i>ITB – e tendering</i>	
Sl.no	Contents
1	Introduction
2	Enrollment Procedure.
3	Technical Settings Required.
4	How to obtain Digital Certificate ?
5	How to access the Tender ? URL .. (web site address)
6	How to Log On ?
7	Pre-requisites to submit tenders on line.
8	How to download Tender Documents ?
9	Clarifications on bidding documents.
10	Submission of a Earnest Money Desposit (EMD) and other documents off line.
11	Bid Preparation.
12	Submission of Bid on line.
13	Opening (Downloading) of Bids.
14	Expiry date
15	Help line
Form A	Form A for New Vendors
Form B	Form B for Existing Vendors



Corporate Materials Management

INSTRUCTIONS TO BIDDERS for e-tenders		
1.0	Introduction	<p>NTPC has implemented SAP ERP application and is adopting internet based electronic tendering through its SRM module.</p> <p>Bidders are required to enroll themselves on the NTPC e-Tendering portal to participate in any tender. The following section outlines the procedure for 'Vendor Enrollment'</p>
2.0	Enrollment Procedure	<p>Bidders are required to have a User ID & password for accessing NTPC e-Tender site. (Vendor may change the password subsequently.)</p> <p>Obtaining User Id & password to access NTPC's e-Tender site</p> <p>A. For NEW VENDORS :</p> <p>If you are not a supplier of NTPC, and interested in participating in e-Tenders in NTPC, please use Form A.</p> <p>Form A-New Vendor (prospective)</p> <p>Note: Please double click on the icon on left side to download the form.</p> <p>The form may be filled in and submitted to the package - in - charge for vendor replication in SRM in NTPC.</p> <hr/> <p>B. For EXISTING VENDORS :</p> <p>If you are already a supplier of NTPC, and interested in participating in e-Tenders of NTPC, please use Form B.</p> <p>Form B -For Existing Vendors:</p> <p>Note: Please double click on the icon on left side to download the form.</p> <p>Please tick the appropriate box in front of vender code to indicate whether the vendor code given is Pre-ERP or Post ERP.</p> <p>The form may be filled in and submitted to the package - in - charge for vendor replication in SRM in NTPC.</p> <hr/> <p>C. PAYMENT OF TENDER FEE (Cost of Bid documents) : For open tenders only :</p> <p>Tender fee (<i>i.e. cost of bid documents</i>) can be <i>paid</i> through DD or payment Gateway.</p> <p>In case the payment is opted through DD, <i>it</i> should be in favor of "NTPC Ltd" payable at the ordering location mentioned in the Bid invitation.</p> <p><i>Vendors registered with NSIC and SSI units of the respective state are exempted from payment of Tender fee.</i></p> <p>Request for User ID & password may be sent through E-mail or manually to the Package in charge / Contact person as mentioned in the NIT/Bid Invitation.</p>



Corporate Materials Management

3.0	Technical Settings required	<p>Following Technical Settings are required by the bidders for participating in e-bidding</p> <ol style="list-style-type: none">1. Web Browser: Internet Explorer version 7.0 or above2. Java: To view some of the components, bidders are required to install Java Internet component JAVA TM 6 update 31 or above from: http://www.oracle.com/technetwork/java/archive-139210.html3. Proxy: If you are unable to access NTPC e-Tender site or Bid Documents, check if you are using proxy to connect to internet or if your PC is behind any firewall. Contact your system administrator to enable connectivity. Please note that Port 443 and 8010 connectivity should be enabled on your proxy/firewall. Using Broad band without Proxy settings is another option and is strongly recommended.4. Pop-ups: Pop-ups should be enabled on NTPC e-Tender URL and Bid Documents URLs. This is required to view Bid Invitation documents.5. Recommended Screen Resolution: 1024 by 768 pixels.6. Internet Speeds: If you are experiencing slow connectivity to NTPC e-Tender, then contact your system administrator/ (ISP) Internet Service Provider for desirable speeds. Also ensure that you are connected to the internet only through a broadband connection and not through LAN.7. Active-x controls: Maintain the settings as described in Internet Explorer settings document to enable digital signature signing and Verification.8. Client SW/Component : A client level Software is required. This is installed automatically, once you start working on NTPC's e-Tender. You need to ensure that you have administrative rights on the PC or the laptop. This installation is one time activity for a PC or Laptop.9. Digital signature: In order to bid for NTPC e-Tenders all the vendors are required to obtain a legally valid digital certificate (Class-IIIB with Company Name) This is a third party software and is available from the agencies listed here under at 4.0
4.0	How to obtain Digital Certificate ? Apply for a class III B digital certificate	<p>As per Indian IT Act, Digital Certificates can be obtained from the licensed Certifying Authorities (CA) operating under the Root Certifying Authority of India (RCAI), Controller of Certifying Authorities (CCA) of India. (http://www.cca.gov.in/)</p> <p>Steps for obtaining Digital Certificate</p> <p>Visit the site of the licensed CA using internet browser. (http://www.cca.gov.in/) following are the issuing authorities</p> <ol style="list-style-type: none">1. TCS http://www.tcs-ca.tcs.co.in2. Safescrypt. http://www.safescrypt.com3. Ncode. http://www.ncodesolution.com4. E-Mudhra http://www.e-mudhra.com5. IDRBTC A http://www.idrbtca.org.in <p>The designated individual who is authorized by your company to submit the bid / offer on line has to apply for digital certificate of class III B with company's name to any of the above issuing authorities with documents as required by them. Ensure the Digital Certificate is legally valid in India.</p> <p>For making payment for Digital Certificate and submission of documents required for issue of the Digital Certificate, follow the instructions on the website of the issuing authority to whom applied.</p> <p>Use the class IIIB Digital Certificate with company name thus obtained for</p>



Corporate Materials Management

		online bidding on NTPC e-Tender site.
5.0	How to access the tender	<p>Open Internet Explorer. To access SRM site, type the following web address (Uniform Resource Locator (URL):</p> <p>https://etender.ntpclakshya.co.in/sap/bc/gui/sap/its/bbpstart</p> <p>SRM site can be accessed through NTPC Tender site also. To access NTPC Ltd. e-Tender site, please type the following web address :</p> <p>http://www.ntpctender.com/</p> <p>And go to etender site by using the link</p> <p>" click here" under " LOGIN (etender) "</p>
6.0	How to Log on?	<p>Enter User ID and Password in the spaces provided for 'Users' and 'Password' in Log On screen and click 'Log On' button at the bottom of the Log on block.</p> <p>The password is used to validate your login credential. Please make note of it for future reference and maintain confidentiality. Your login on the e-Tendering portal can be operated by anybody in possession of the password. Therefore, it is an advisable practice to change your password at regular intervals.</p>
7.0	Pre-requisites to submit tenders on line	<p>In order to access NTPC e-Tender site , Bidders should have</p> <ul style="list-style-type: none"> ❖ Valid User ID and Pass Word. ❖ Class-III'B digital Certificate, with Company Name ❖ Internet connectivity, with broadband. ❖ Tender Fee(Cost of tender documents), if applicable. <p>In case, Bidder(s) is (are) seeking exemption from paying tender fee, they are required to have an exemption from Package - in - charge/ Contact person as mentioned in the Notice Inviting Tender (NIT) / Bid Invitation , by furnishing the documentary evidence (viz. MSE certificate as applicable).</p> <p>Bidder should fulfill other pre-requisites, if any, mentioned in the tender documents of the specific tender.</p>
8.0	How to Download Tender Documents?	<p>It is recommended that the bidder downloads various sections of the tender documents and study them carefully before starting preparation of the bid.</p> <p>The procedure for the same is as follows:</p> <ul style="list-style-type: none"> ❖ Type the URL <p>https://etenders.ntpclakshya.co.in/sap/bc/gui/sap/its/bbpstart</p> <ul style="list-style-type: none"> ❖ log in by using the user ID and Password ❖ Search the required NIT. ❖ Click on the NIT number. ❖ Click on the Document tab. ❖ Click on the Collaboration folder (c_Folder) and one by one, download the required section of tender documents. <p>NOTE :- Bidders are advised to ensure that they have understood the NTPC Tender document and have fully downloaded the tender documents from C_Folder before choosing the option of Creating Bid Options</p>
9.0	Clarification on Bidding Documents	<p>Bidder(s) are advised to go through the Bidder's Manual available on line after opening the site : https://etender.ntpclakshya.co.in/sap/bc/gui/sap/its/bbpstart</p> <p>Bidder can also send queries seeking clarifications through e-mail or in</p>



Corporate Materials Management

		<p>hard copy any time up to 7 days prior to last date for submission of bid.</p> <p>The queries will be answered by NTPC and posted in the c-Folder. The bidders can view all queries and all answers once they are posted in the c-Folder.</p>
10.0	<p>Submission of Earnest Money Deposit (EMD) & other documents off Line</p>	<p>Bidders who wish to submit their bids must send EMD in any of the modes as stipulated in "General Purchase Condition" in the Bid Documents.</p> <p>The bidders are requested to send the sealed envelopes well in advance so as to be received by the respective officer before the scheduled date of closing of submission of bids as described in the time schedule in Notice Inviting Tender, failing which the bid is liable for rejection. NTPC shall not be liable for loss/non-receipt/late receipt of EMD in postal transit.</p> <p>Submission of EMD & other documents off Line :</p> <p>The bidders are requested to send following documents in sealed envelopes well in advance so as to be received by the respective officer before the submission closing date and time of bids as described in the time schedule in NIT failing which bid is liable for rejection.</p> <ul style="list-style-type: none"> ➤ EMD ➤ Authorization of Principle (OEM / OES / Manufacturer / etc.) * ➤ MSE certificate (if any) ** <p>* Wherever Bid is submitted on behalf of the Principal to whom the tender enquiry has been issued, the certificate of Authorization as per format at Annexure-I to this document is to be submitted along with EMD.</p> <p>** For exemption from submission of EMD as per General Purchase Condition (GPC), bidder shall have to submit Valid MSE certificate as per MSMED Act 2006, if applicable.</p>
11.0	<p>Bid Preparation</p>	<p>Bidders may refer to the enclosed Bidders Manual with screen shots for preparation of bids</p> <p>The major steps in preparation of bid are as follows:</p> <ul style="list-style-type: none"> ❖ Read the NIT received along with the mail. ❖ Go to URL " https://etender.ntpclakshya.co.in/sap/bc/qui/sap/its/bbpstart" or NTPC Tender site and click on the e-Bidding Tab. ❖ Enter the User ID and Password ❖ Go to "Process Bid" screen, showing the Main screen of the bid invitation of all the details of the Bid invitation and select the desired Bid invitation number. ❖ Go to "Information from Purchaser" tab to check other details of Bid invitation. ❖ Click on the collaboration folder (C-Folder) to access detailed Bid documents under various sub folders. ❖ Click on the Attribute Tab under General data Tab to check list of confirmations asked in the bid invitation and convey the required compliance, failing which bid submission may not be possible. ❖ Before preparing the bid, click on "Register" and "Create" tab ❖ Complete the bid forms in the bid preparation step as prescribed before the expiry date for "Bid Submission" in the time schedule displayed in the notice inviting tender.



12.0	<p>Procedure for bid Submission</p>	<ul style="list-style-type: none"> ❖ While completing the bid forms make sure that the bid is digitally signed and submitted. ❖ Bids can be submitted by clicking on the "Submit" Tab and attaching relevant Digital Certificates. ❖ The status of the Bid can be checked for the "Process Bids" screen at any time after submission of the bid. <p>No deviation, whatsoever, is permitted by the Owner to any provisions of Bidding Documents.</p> <p>The acceptance of above is an attribute of the on line Bid Invitation and the Bidders are required to confirm acceptance of Compliance to All Provisions of Bidding Documents (NIL Deviation Certificate) on line as per format.</p> <p>Only after acceptance of the above condition the bidder shall be allowed to submit the bid.</p> <ul style="list-style-type: none"> ❖ In case any deviations, variations and additional conditions are found anywhere in the bid (Techno Commercial Bid & Price Bid) , the same shall not be given effect to in evaluation and it will be considered that the bidder complies to all the terms and conditions of Bidding Documents without any extra cost to the Owner irrespective of any mention to the contrary, any where in the bid, failing which the Bid Security of the Bidder be forfeited.
12.1	<p>Submission (up loading) of Bid.</p>	<p>The vendor will submit their quotation online after carefully examining the document/conditions and the schedule of work.</p> <p>At any point during the Bid preparation click on the "Hold" button to temporarily save the bid.</p> <p>Technical & Price Bids will be prepared online.</p> <p><u>A. UP Loading in C_Folder</u></p> <p>Bidder shall upload their bid in the appropriate C-Folder tab in the bid area after Digital Signature are attached, under the "Un-priced Bid" w.r.t the tender requirements, defined in the tender documents viz.</p> <ul style="list-style-type: none"> ❖ Technical details & data sheets (if any) ❖ Commercial offer ❖ Various drawings and other documents (if any) <p><u>B. ON Line PRICE (BPS)</u></p> <ul style="list-style-type: none"> ❖ Go to Item data to view the list of Items and quote the prices against each item. Also fill the prices for various price conditions which can be viewed by clicking on "See Conditions" button. <ul style="list-style-type: none"> ❖ All the prices are to be filled in at the relevant fields in pricing conditions. ❖ "In case any price condition is left blank, the same is considered to be included in the basic price." <p><u>C. Reverse Auction (RA)</u></p> <ul style="list-style-type: none"> ❖ Bidders may note that, only those whose technical bids are technically compliant will be allowed to participate in Online Reverse Auction, if applicable and as indicated in the Special Purchase Condition(SPC).



Corporate Materials Management

13.0	Opening / (Down loading) of Bids.	<p>After expiry of Bid Submission time and before bid opening time, NTPC officials shall be authorized to view the number of bids uploaded / received. However, bid details can't be viewed before bid opening time.</p> <p>The Committee or their authorized representatives shall open the EMD documents first (received off line). The Committee, shall allow only those bids to be downloaded whose EMDs have been received in NTPC and are adequate and acceptable as per conditions of the bid document.</p> <p>Composite bidding :</p> <p>The composite bid of only those bidders, whose EMD has been found in order as stipulated will be opened and considered for evaluation.</p> <p>Single stage ,TWO envelope (Tech. bid & Price bid) bidding :</p> <p>In case of Single stage , 2 envelope bidding,</p> <ul style="list-style-type: none">❖ Technical Bid shall be opened of those bidders whose EMD 's have been found in order and meeting other tender conditions, as stipulated in tender documents.❖ Price bids, shall be opened on a later date of only those bidders whose technical bid is found acceptable and who fulfill the Qualifying Requirements (if any). <p>The date of Price bid opening of such qualified bidders shall be separately intimated and only these qualified bidders will be eligible to participate in the Reverse Auction, if applicable.</p>
14.0	Expiry Date	<p>The online bidding system will not allow bid submission after the respective specified expiry date and time. Bidders are advised to make sure that the bid submission is completed well in advance before the stipulated time for bid submission .</p>
15.0	Help line	<p>In case of any difficulty, kindly get in touch with the concerned package-in-charge specified in the Special Purchase Conditions/NIT/Tender Enquiry.</p> <p>You may also contact the concerned executive, for the location from where the tender has been issued, mentioned under "Contact us" on the logon page, for assistance on process understanding, compliance, training needs etc.</p> <p>In case of login related issues and in case of any emergency please get in touch with our Central Helpdesk at the number indicated under "Contact us".</p>



Volume-I

SECTION – II

GENERAL PURCHASE CONDITIONS

(G P C)

**NTPC LIMITED.
CORPORATE MATERIALS
ENGINEERING OFFICE COMPLEX,
A-8A, SECTOR- 24, NOIDA -201301 (UP) INDIA**

Sl. no	Index
1	Introduction
2	General Information
2.1	Benefits to MSEs
3	Definitions & Terminology
4	Bidding Documents
4.1	Clarifications on Bidding documents
4.2	Amendments to Bidding documents
5	Preparation Of Bid Proposals
6	Cost of Bidding
7	Language of Bid
8	Validity of Offer
9	Bid Security / Earnest Money Deposit (EMD)
10	Conditions For Forfeiture of EMD/Bid Security
11	Release of EMD/Bid Security
12	Ineligibility for Future Tenders
13	Preparation of Bid Proposal
13.1	Documents in Support of Qualifying Requirements (QR)
13.2	Technical Proposal
13.3	Price Proposal
14	Certificate of Compliance
15	No Deviations Clause
16	Time Schedule
17	System Processing Time
18	Documents Comprising the Bid
19	Submission of EMD & Other documents-Off-Line
20	Submission Of Bid Proposal
21	Submission Of Bid Proposal.. off line
22	On Line Uploading Of Documents & Prices
23	Expiry Date or Deadline For Submission Of Bids
24	Uploading of Bid
25	Procedure for down loading (Opening) of Bids
26	Determination of Responsiveness
27	Evaluation Criteria
28	Evaluation of Bids
29	Discrepancies in Bid
30	Clarification Of Bids
31	Contacting the Employer
32	Employer's Right to Accept Any Bid and to Reject Any Or All Bids
33	Award Criteria
34	Contract
35	Construction of Contract
36	Delivery Schedule
37	Contract Price
38	Scope of Supply
39	Contract Performance Guarantee (CPG)/PBG
40	Authorised Representative
41	Insurance
42	Freight
43	Packing

44	Inspection and Tests
45	Warranty
46	Patents
47	Indemnification
48	Removal of Rejected Goods and Replacement
49	Modification of Contract
50	Liquidated Damages
51	Force Majeure
52	No Breach of Contract
53	Obligations of the Bidder
54	Risk Purchase
55	Settlement of Disputes
56	Notices
57	Termination
58	Taxes & Duties
59	Entry Tax
60	Road Permit
61	Tax Deduction at Source
62	Payments to the Successful Bidders
63	Procedure of Payment
64	Jurisdiction
65	Limitation of Liability
66	Fraud Prevention Policy
67	Integrity Pact
68	Indian Agents

The Special Purchase Conditions (SPC) will supersede any related conditions any where in the Bidding Documents and will prevail for evaluation / finalization of the tender.

1.0	NTPC Limited, a Govt. of India Enterprise referred to herein as ‘the Employer’, intends to engage an agency for supply of Goods and related Services as per specifications, Scope of Work as detailed in the Bidding documents.	
2.0	GENERAL INFORMATION	The prospective Bidders are invited to submit a “Technical & Commercial Proposal” and “Price proposal” for the package. Methodology for submission of proposal has been detailed hereunder in this document.
2.1	BENEFITS TO MSEs	<p>Micro and Small Enterprises (MSEs) registered with District Industries Centres or Khadi and Village Industries Commission or Khadi and Village Industries Board or Coir Board or National Small Industries Corporation or Directorate of Handicrafts and Handloom or any other body specified by Ministry of Micro, Small and Medium Enterprises as per MSMED Act 2006, for goods produced and services rendered, shall be issued the bid documents free of cost and shall be exempted from paying Earnest Money Deposit.</p> <p>Further, in case of tenders where splitting of quantity is possible, participating MSEs quoting price within price band of L1 + 15 percent shall also be allowed to supply a portion of requirement by bringing down their price to L1 price in a situation where L1 price is from someone other than a Micro and Small Enterprise and such Micro and Small Enterprise shall be allowed to supply up to 20 percent of total tendered value. In case of more than one such MSE, the supply will be shared proportionately (to tendered quantity).</p> <p>However, in case of tenders where splitting of quantity is not possible, participating MSEs quoting price within price band of L1 + 15 percent shall be allowed to execute the package by bringing down their price to L1 price in a situation where L1 price is from someone other than a Micro and Small Enterprise. The award shall be made as follows:</p> <p>Award shall be given to L1 bidder if L1 bidder is a MSE.</p> <p>In case L1 bidder is not a MSE, then all the MSE vendor(s) who have quoted within the range of L1 + 15%, shall be given the opportunity in order of their ranking (starting with the lowest quoted MSE bidder and so on) to bring down its price to match with L1 bidder. Award shall be placed on the MSE vendor who matches the price quoted by L1 bidder.</p> <p>If no MSE vendor who has quoted within range of L1 + 15% accepts the price of L1 bidder, then the award shall be made to the L1 bidder.</p> <p>The benefit as above to MSEs shall be available only for goods/services produced & provided by MSEs.</p> <p>MSEs seeking exemption and benefits should enclose an attested/self-certified copy of registration certificate, giving details such as stores/services, validity (if applicable) etc. failing which they</p>

		run the risk of their bid being passed over as ineligible for the benefits applicable to MSEs. Note: <i>Generally in tenders having Itemwise evaluation, splitting is allowed unless otherwise specified in the Special Purchase Conditions (SPC). Further, in tenders having Packagewise evaluation generally splitting is not allowed. Please refer Special Purchase Condition for specific tender provisions.</i>	
3.0	DEFINITIONS & TERMINOLOGY	Unless the context otherwise requires, the following terms whenever used in this Contract have the following meanings:	
		“Applicable Law” - This Contract including all matters connected with this Contract shall be governed and construed in accordance with the Indian Law both substantive and procedural and shall be subject to the exclusive jurisdiction of Indian courts at Delhi(India).	
		“Contract” means the Contract Agreement entered into between the Employer and the Contractor, together with the Contract Documents referred to therein; they shall constitute the Contract, and the term “the Contract” shall in all such documents be construed accordingly.	
		“Contract Price” means the price to be paid for the performance of the Services, in accordance with the payment terms, subject to such additions and adjustments thereto or deductions there from, as may be made pursuant to the Contract.	
		“Government” means the Government of the Employer’s country ie INDIA.	
		“Local Currency” means the currency of the Government of India.	
		“Party” means the Employer or the Bidder, as the case may be, and “Parties” means both of them.	
		“Personnel” means persons hired by the Bidder as employees and assigned to the performance of the Services or any part thereof.	
		“Services” means the work to be performed by the Bidder pursuant to this Contract, as described in the detailed Terms of Reference; and	
		Law Governing the Contract : The Contract, its meaning and interpretation, and the relation between the Parties shall be governed by the Applicable Law.	
Language : English shall be the binding and controlling language for all matters relating to the meaning or interpretation of this Contract.			
4.0	BIDDING DOCUMENTS	<i>Tender document consist of following sections</i>	
		1 NIT	On-line
		2 Volume-I, Section-I	Instruction to bidder
		3 Volume-I,	General Purchase Conditions

		Section-II	
		4 Volume-I, Section-III	Reverse Auction Rules & Procedure (Not Applicable)
		5 Volume-I, Section-IV	Forms/Bid Data Sheet
		6 Volume-II, Section-I	Special Purchase Conditions
		7 Volume-III	Technical specifications & scope of work
		Price Schedule	On-line
4.1	CLARIFICATION ON BIDDING DOCUMENT	A prospective Bidder requiring any clarification of the Bidding Document shall contact the Employer in writing at the Employer's e-mail address given in the bidding documents. The Employer shall forward copies of its response to all Bidders who have obtained the Bidding Document directly from it. Should the Employer deem it necessary to amend the Bidding Document as a result of a clarification, it shall do so and intimate to all who have obtained the Bidding Document directly from the Employer.	
4.2	AMENDMENT TO BIDDING DOCUMENT	<p>a) At any time prior to the deadline for submission of the Bids, the Employer may amend the Bidding Document by issuing addenda.</p> <p>b) Any addendum issued shall be part of the Bidding Document and shall be communicated to all who have obtained the Bidding Document directly from the Employer.</p> <p>c) To give prospective Bidders reasonable time in which to take an addendum into account in preparing their Bids, the Employer may, at its discretion, extend the deadline for the submission of the Bids.</p>	
5.0	PREPARATION OF BID PROPOSALS	<p>a) Proposals shall be complete in all respects and shall be submitted with requisite information and Annexure. It shall be free from any ambiguity.</p> <p>b) For preparation of Proposals, Bidders are expected to go through the complete bidding documents carefully. Material deficiencies in providing the information requested may result in rejection of the proposal.</p>	
6.0	COST OF BIDDING	The Bidder shall bear all costs associated with the preparation and submission of its Bid, negotiation, discussion etc. and the Employer shall not be responsible or liable for these costs, regardless of the conduct or outcome of the bidding process.	
7.0	LANGUAGE OF BID	<p>The Bid, as well as all correspondence and documents relating to the Bid exchanged by the Bidder and the Employer, shall be written in English. Supporting documents and printed literature that are part of the Bid may be in another language provided they are accompanied by an accurate translation of the relevant passages in English, in which case, for purposes of interpretation of the Bid, such translation shall govern.</p> <p>The English Translation of the documents shall be carried out by professional translators and the translator shall certify that he is</p>	

		proficient in both languages in order to translate the document and that the translation is complete and accurate. Further, translation shall be authenticated by the Indian Consulate located in the Country where the documents have been issued or the Embassy of that Country in India.
8.0	VALIDITY OF OFFER	The proposals shall remain valid for a period as specified in Special Purchase Conditions (SPC) from the date of opening of BID. In exceptional circumstances the Employer may solicit the Bidder's consent for extension of the bid validity period. When the validity period of the offer is extended by the Bidder, the same shall be done without any modification to the bid proposal by the Bidder.
9.0	BID SECURITY / EARNEST MONEY DEPOSIT (EMD)	<p>a) The bid security shall, at the Bidders option, be in the form of</p> <ol style="list-style-type: none"> 1) a Crossed Demand Draft/Pay Order/Bankers Cheque drawn in favour of NTPC Ltd. Payable at New Delhi/Noida/Delhi, <p style="text-align: center;">OR</p> <ol style="list-style-type: none"> 2) irrevocable Letter of Credit or a bank guarantee from any of the banks specified in Attachment 4 of Volume I Section IV. <p>b) In case of Foreign Bidders, the Bid Security can be from any other Bank also in addition to the Banks specified in Volume I Section IV and if the Bank Guarantee is from a Bank not specified in Volume I Section IV, then the Bank Guarantee shall be confirmed by any of the Banks specified in Volume I Section IV.</p> <p>c) The format of Bid Guarantee or Letter of Credit shall be in accordance with the form of bid security included in the bidding documents.</p> <p>d) The bid Security shall remain valid for a period of forty five (45) days beyond the original Bid validity period or beyond any extension in the period of Bid validity subsequently requested.</p> <p>e) Any bid not accompanied by an acceptable Bid Security in accordance with aforesaid provisions shall be rejected by the Employer as being non-responsive and will not be opened.</p> <p>f) Wherever Bids under Joint Venture route are permitted as per the Qualifying Requirements in the Bidding Documents, the Bid Security by the Joint Venture must be on behalf of all the partners of the Joint Venture.</p>
10.0	CONDITIONS FOR FORFEITURE OF EMD / BID SECURITY	<p>The Earnest Money Deposit / Bid Security may be forfeited in any of the following circumstances by the Employer/Employer without any notice or proof of damage to the Employer, etc.</p> <ol style="list-style-type: none"> a) If the Bidder withdraws or varies it's Bid during the period of Bid validity; b) If the Bidder does not accept the correction of its Bid Price pursuant to clause 29.0; c) If any deviation, variation, additional condition or any other mention is found anywhere in the Price bid, contrary to the provisions of bidding documents;

		<p>d) In the case of a successful Bidder, if the Bidder fails within the specified time limit</p> <p>i) To sign the Contract Agreement in accordance with Clause 34.0 and/or ;</p> <p>ii) To furnish the required Contract Performance Guarantee/Security Deposit, in accordance with Clause 39.0 .</p> <p>e) If the bidder / their representative commit any fraud while competing for this contract pursuant to Fraud prevention policy of NTPC.</p> <p>f) In case the bidder / Contractor/Contractor is disqualified from the bidding process in terms of section 3 & 4 of Integrity pact.</p>
11.0	RELEASE OF EMD / BID SECURITY	<p>a) The bid Security of all those bidders who are not considered Techno-commercially responsive and / or qualified will be returned not later than 1 month from calling for Stage II (Price bid).</p> <p>b) The Bid Security of all the unsuccessful Bidders shall be returned as promptly as possible but not later than 1 month after expiration of bid validity or after award / finalization of the case which ever is earlier.</p> <p>c) The Bid Security of the successful Bidder to whom the Contract is awarded when the said bidder has signed the contract Agreement and furnished the required Contract Performance Guarantee.</p>
12.0	INELIGIBILITY FOR FUTURE TENDERS	Notwithstanding the provisions regarding forfeiture of Bid Security specified above, if a bidder after having been issued the Letter of Award/Purchase Order/Service Purchase Order, if a bidder after having been issued the Letter of Award/Purchase Order/Service Purchase Order, either does not sign the Contract Agreement pursuant to Clause 34.0 or does not submit a acceptable Contract Performance Guarantee/Performance Security pursuant to Clause 39.0, and which result in tender being annulled then such bidder shall be treated ineligible for participation in re-tendering of this particular package.
13.0	Preparation of Bid Proposal	
13.1	DOCUMENTS IN SUPPORT OF QUALIFYING REQUIREMENTS (QR)	The bidder shall furnish documentary evidence in support of meeting the Qualifying Requirements if stipulated in the Notice Inviting Tender (NIT) and Special Purchase Conditions (SPC).
13.2.	TECHNICAL PROPOSAL	<p>a) To establish the conformity of the Goods and related Services to the Bidding Document, the Bidder shall furnish as part of its Bid, the documentary evidence wherever applicable that the Goods and related Services conform to the requirements specified.</p> <p>b) Apart from the technical requirements as stipulated in the bidding documents, data sheets etc. the documentary evidence may be in the form of literature, drawings or data, and shall consist of a</p>

		detailed item-by-item description of the essential technical and performance characteristics of the Goods and related Services, demonstrating substantial responsiveness of the Goods and related Services to those requirements.
13.3	PRICE PROPOSAL	<p>a) For preparation of the 'Price Proposal', Bidders are expected to take into account the requirements and conditions of the bidding documents. The Price Proposal shall be made on-line in 'Bid Price Schedule' of Bidding Documents.</p> <p>b) The rate quoted by the bidder shall be inclusive of all provisions for incidental expenses necessary for proper execution and completion of the work in accordance with the terms & condition of the bidding document.</p> <p>c) All prices to be quoted by the bidders will be in Indian Rupees only , unless otherwise mentioned in the special conditions , on firm price basis and to remain valid during the currency of the Contract.</p> <p>d) Bidders shall necessarily submit the prices in the Bid Price Schedule only and submit on-line.</p>
14.0	CERTIFICATE OF COMPLIANCE	<p>No deviation, whatsoever, is permitted by the EMPLOYER to any provision of Bidding Documents. The Bidders are advised that while making their Bids and quoting prices, all conditions are appropriately taken into consideration. Bidders shall certify their compliance to the complete Bidding Documents as per Certificate at Annexure 01 of Volume I Section IV by accepting the following 'Attribute' of the Tender:</p> <p>"Do you certify full compliance to all provisions of Bid Doc?"</p> <p>In case the Products and/or Services offered do not meet the Technical requirements, the bid shall be rejected as Technically non-responsive.</p>
15.0	NO DEVIATIONS	<p>Bidders may note that in case the Bidder refuses to withdraw additional conditions/deviations/exceptions/implicit or explicit, found anywhere in the techno-commercial bid, the bid shall be rejected as Technically non-responsive.</p> <p>Bidders may also note that any deviation/variation in any form in the Price Bid shall result in forfeiture of EMD.</p>
16.0	TIME SCHEDULE	Bids must be uploaded on the system well before the expiry of time and the schedule specified in the tender notifications, and may note that there is a time lag between the actual placing the bid on the local computer of the bidder and the refreshing of the data on the server for the visibility to the Employer.
17.0	SYSTEM PROCESSING TIME	The processing time for data exchange is 2-3 minutes, so bidder should avoid the last minute hosting of their bid. The bids visible to the Employer will be final for the purpose of acceptance.
18.0	DOCUMENTS COMPRISING THE	<p>The Bid shall comprise the following :</p> <ol style="list-style-type: none"> 1. Earnest Money Deposit;

	BID	<ol style="list-style-type: none"> 2. Acceptance of 'Compliance to Bidding Documents (NIL Deviation Certificate)' 3. Acceptance of 'Fraud Prevention Policy'; 4. Acceptance of Banning Policy of NTPC 5. Documentary evidence establishing the Bidder's eligibility to bid; 6. Technical specifications of the items and services & scope of work offered; 7. EFT Form 8. Bid Price Schedules ; and 9. any other details required in the Bid Document.
19.0	SUBMISSION OF EMD & OTHER DOCUMENTS - OFF LINE	<p>The bidders are requested to send following documents in sealed envelopes well in advance so as to be received by the respective officer before the scheduled date of submission / opening of bids as described in the time schedule in notice inviting tender failing which bid is liable for rejection.</p> <ul style="list-style-type: none"> ➤ EMD ➤ Authorization from bidder to whom Tender Enquiry has been issued (if applicable) * ➤ MSE certificate as per MSMED Act 2006 (if any) ** ➤ Any other document asked for in the SPC <p>* Wherever Bid is submitted on behalf of a Principal (OEM / OES / Manufacturer), the certificate of Authorization as per format at Annexure-03 to this document is to be submitted along with EMD. However, this provision shall not be applicable for OPEN Tenders.</p> <p>** For exemption towards submission of EMD above bidder shall have to submit necessary certificate.</p> <p>NTPC shall not be liable for loss/non-receipt/late receipt of documents in transit.</p> <p>However, the copies of the EMD details shall be uploaded. In case of bidders who are exempted from submitting EMD, the necessary documents shall be uploaded.</p>
20.0	SUBMISSION OF BID PROPOSAL	<ol style="list-style-type: none"> a. Bidders are requested to submit the bids on line on NTPC SRM Portal. b. Bids shall be hosted / uploaded on the system as per the schedule date & time specified in the tender notification / enquiry.
21.0	SUBMISSION OF BID PROPOSAL OFF LINE	<p>The bids shall be submitted as detailed here under :</p> <p>OFF-LINE</p> <ul style="list-style-type: none"> ➤ Envelope-1... marked as 'EMD' <ol style="list-style-type: none"> a) Bid Form 1 b) EMD / Bid Security c) MSE certificate as per MSMED Act 2006 (if any)

		<p>d) Any other document specified in Special Purchase Condition These documents will be checked before down loading (opening) of the Technical bid and only those bids where valid documents are available will be allowed for down loading (opening).</p> <p>a. Envelope-2 ... marked 'QR'</p> <p>In case of open tenders , Bid Form 2 along with copy of the documents in support of meeting Qualifying Requirements which can not be up - loaded on-line (like Annual Report, PO Copies, Authorization from Principal etc.) , may be submitted off line.</p> <p>These documents will be checked along with the Technical bid and</p> <p>b. The On Line Price bids of only those bidders will be down loaded (opened) at a later date (under intimation to them) who meet the Qualifying Requirements and whose bids are technically acceptable.</p> <p>Bidders are advised to ensure that the above should reach the addressee (Employer) before the last date & Time for submission of Bid as specified in the NIT / Tender enquiry / Special Purchase Conditions (SPC).</p>																								
22.0.	ON LINE UPLOADING OF DOCUMENTS & PRICES	<p>(A) Acceptance of Compliance to All Provisions of Bidding Documents (NIL Deviation Certificate) {Attachment 14} (*)</p> <p>(B) Acceptance of Fraud Prevention Policy { Attachment 15} (*)</p> <p>(C) Acceptance of Declaration on Banning Policy{Attachment 16} (*)</p> <p>(D) Do you certify full compliance on Qualifying Requirements? {Annexure 21} *</p> <table border="1" data-bbox="584 1323 1417 1955"> <tr> <td colspan="3" data-bbox="584 1323 1417 1413">In collaboration folder (c-folder) under Un-Priced bid tab Upload the following</td> </tr> <tr> <td data-bbox="584 1413 667 1464"></td> <td data-bbox="667 1413 959 1464"></td> <td data-bbox="959 1413 1417 1464">Contents</td> </tr> <tr> <td data-bbox="584 1464 667 1516">(i)</td> <td data-bbox="667 1464 959 1516">EMD</td> <td data-bbox="959 1464 1417 1516">EMD details</td> </tr> <tr> <td data-bbox="584 1516 667 1644">(ii)</td> <td data-bbox="667 1516 959 1644">MSE / MSME</td> <td data-bbox="959 1516 1417 1644">MSE certificate as per MSMED Act 2006 (if any) (Valid certificate to be furnished) .</td> </tr> <tr> <td data-bbox="584 1644 667 1731">(iii)</td> <td data-bbox="667 1644 959 1731">Attachment 7</td> <td data-bbox="959 1644 1417 1731">Qualification Data with other Attachments (A to G)</td> </tr> <tr> <td data-bbox="584 1731 667 1783">(iv)</td> <td data-bbox="667 1731 959 1783">Attachment 8</td> <td data-bbox="959 1731 1417 1783">Details in respect of Local Agent</td> </tr> <tr> <td data-bbox="584 1783 667 1870">(v)</td> <td data-bbox="667 1783 959 1870">Attachment 9</td> <td data-bbox="959 1783 1417 1870">Guarantee Declaration</td> </tr> <tr> <td data-bbox="584 1870 667 1955">(vi)</td> <td data-bbox="667 1870 959 1955">Attachment 10</td> <td data-bbox="959 1870 1417 1955">Milestone Schedule</td> </tr> </table>	In collaboration folder (c-folder) under Un-Priced bid tab Upload the following					Contents	(i)	EMD	EMD details	(ii)	MSE / MSME	MSE certificate as per MSMED Act 2006 (if any) (Valid certificate to be furnished) .	(iii)	Attachment 7	Qualification Data with other Attachments (A to G)	(iv)	Attachment 8	Details in respect of Local Agent	(v)	Attachment 9	Guarantee Declaration	(vi)	Attachment 10	Milestone Schedule
In collaboration folder (c-folder) under Un-Priced bid tab Upload the following																										
		Contents																								
(i)	EMD	EMD details																								
(ii)	MSE / MSME	MSE certificate as per MSMED Act 2006 (if any) (Valid certificate to be furnished) .																								
(iii)	Attachment 7	Qualification Data with other Attachments (A to G)																								
(iv)	Attachment 8	Details in respect of Local Agent																								
(v)	Attachment 9	Guarantee Declaration																								
(vi)	Attachment 10	Milestone Schedule																								

		<table border="1"> <tr> <td>(vii)</td> <td>Attachment 11</td> <td>Details of Proposed Sub-Contractors/Sub-Vendors</td> </tr> <tr> <td>(viii)</td> <td>Attachment 12</td> <td>E.F.T. Form</td> </tr> <tr> <td>(ix)</td> <td>Attachment 12A</td> <td>Details of PAN, TIN and Service tax regn. for Indian bidders</td> </tr> <tr> <td>(x)</td> <td>Technical Data Sheets</td> <td>Technical Data Sheet</td> </tr> <tr> <td>(xi)</td> <td>Catalogues, Literature etc.</td> <td>Catalogues, Literature etc. in compliance to Technical Requirements</td> </tr> <tr> <td>(xii)</td> <td colspan="2">Documents in compliance to Technical Requirements</td> </tr> <tr> <td>(xiii)</td> <td colspan="2">Any other documents asked for in the Bidding Documents.</td> </tr> </table> <table border="1"> <tr> <td align="center">Under ITEM DATA TAB fill / submit the following</td> </tr> <tr> <td>Bid Price Schedule</td> </tr> </table> <p>Bidders may note that no price component is to be uploaded in the collaboration -folder.</p> <p>(*) Bidders may note that without Acceptance for Compliance to All Provisions of Bidding Documents (NIL Deviation Certificate), Fraud Prevention Policy which is to be given online, Bidders will not be allowed to create and submit the bid.</p>	(vii)	Attachment 11	Details of Proposed Sub-Contractors/Sub-Vendors	(viii)	Attachment 12	E.F.T. Form	(ix)	Attachment 12A	Details of PAN, TIN and Service tax regn. for Indian bidders	(x)	Technical Data Sheets	Technical Data Sheet	(xi)	Catalogues, Literature etc.	Catalogues, Literature etc. in compliance to Technical Requirements	(xii)	Documents in compliance to Technical Requirements		(xiii)	Any other documents asked for in the Bidding Documents.		Under ITEM DATA TAB fill / submit the following	Bid Price Schedule
(vii)	Attachment 11	Details of Proposed Sub-Contractors/Sub-Vendors																							
(viii)	Attachment 12	E.F.T. Form																							
(ix)	Attachment 12A	Details of PAN, TIN and Service tax regn. for Indian bidders																							
(x)	Technical Data Sheets	Technical Data Sheet																							
(xi)	Catalogues, Literature etc.	Catalogues, Literature etc. in compliance to Technical Requirements																							
(xii)	Documents in compliance to Technical Requirements																								
(xiii)	Any other documents asked for in the Bidding Documents.																								
Under ITEM DATA TAB fill / submit the following																									
Bid Price Schedule																									
23.0	EXPIRY DATE OR DEAD LINE FOR BID SUBMISSION	<p>The online bidding system will not allow bid submission after the specified expiry date and time. Make sure the bid submission is completed well in advance of the time.</p> <p>Bid shall not be accepted by the server after expiry of the schedule date & time.</p>																							
24.0	UPLOADING OF BID	<p>Bidders shall have to submit bids on line on the NTPC, e-tender Portal (SRM-Portal). All the bidders must upload their bids w.r.t the tender requirements, defined in the tender document. Viz</p> <ul style="list-style-type: none"> ❖ EMD Details. ❖ EFT Form ❖ Qualifying requirement documents (if applicable) ❖ Technical details & data sheets (if any). ❖ Commercial offer ❖ Regn details ❖ Bid price schedule (to be filled on-line) <p>All above details shall be uploaded.</p>																							
24.1	MODIFICATION AND WITHDRAWAL	<p>a. The Bidder may modify or withdraw its bid after submission, provided that written notice of the modification or withdrawal is</p>																							

	OF BID	<p>received by the Employer prior to the deadline prescribed for bid submission. The Employer shall return the bid on the SRM portal for modification or withdrawal.</p> <p>b. A Bidder wishing to withdraw/modify its bid shall notify the Employer in writing prior to the deadline prescribed for bid submission. A withdrawal notice may be sent by mail from the registered e-mail id or post or by telefax so as to be received by the Employer before the deadline for submission of bids. The notice of withdrawal shall</p> <ul style="list-style-type: none"> (i) be addressed to the Employer at the address named in the NIT/SPC, and (ii) bear the NIT/Tender enquiry number, Package name, and the words "BID WITHDRAWAL NOTICE". <p>c. Bid withdrawal notices received after the bid submission deadline will be ignored, and the submitted bid will be deemed to be a validly submitted bid.</p> <p>d. The Employer shall on receipt of the "BID WITHDRAWAL NOTICE" from the bidder, return the bid on the NTPC SRM Portal. The bidder can thereafter re-submit its bid within the time line specified for bid submission. NTPC shall NOT be responsible for the inability of the bidder to submit its bid again within the time line specified. Bidders are NOT allowed to submit any modification through any letter/ e-mail/fax etc. Such communications will not be considered.</p> <p>e. No bid may be withdrawn / modified in the interval between the bid submission deadline and the expiration of the bid validity period. Withdrawal/Modification of a bid during this interval may result in the Bidder's forfeiture of its bid security, pursuant to Clause 10.0(a) above.</p>						
25.0	PROCEDURE FOR DOWN LOADING (OPENING) OF BIDS	<p>After expiry of Bid Submission time and before bid opening time, only authorized NTPC officials can view the numbers of Bid submitted. However, bid details can't be viewed before bid opening time.</p> <p>❖ Opening of Documents Submitted OFF-LINE :</p> <p>The Committee or their authorized representatives shall open the EMD documents received off line (except in those cases where EMD is not applicable). The Committee, based on the EMDs received, shall allow only those on line bids to be downloaded whose EMDs have been received in NTPC and are adequate and acceptable as per conditions of the bid document.</p> <table border="1" data-bbox="593 1736 1406 2020"> <tr> <td data-bbox="593 1736 667 1915">a)</td> <td data-bbox="667 1736 933 1915">Envelope 1 'EMD'</td> <td data-bbox="933 1736 1406 1915"> 1. EMD / Bid Security 2. MSE certificate as per MSMED Act 2006 (if any) 3. Any other document specified in SPC </td> </tr> <tr> <td data-bbox="593 1915 667 2020">b)</td> <td data-bbox="667 1915 933 2020">Envelope 2 'QR'</td> <td data-bbox="933 1915 1406 2020">Documents in support of meeting Qualifying Requirements, if applicable.</td> </tr> </table>	a)	Envelope 1 'EMD'	1. EMD / Bid Security 2. MSE certificate as per MSMED Act 2006 (if any) 3. Any other document specified in SPC	b)	Envelope 2 'QR'	Documents in support of meeting Qualifying Requirements, if applicable.
a)	Envelope 1 'EMD'	1. EMD / Bid Security 2. MSE certificate as per MSMED Act 2006 (if any) 3. Any other document specified in SPC						
b)	Envelope 2 'QR'	Documents in support of meeting Qualifying Requirements, if applicable.						

		<p>❖ Down loading of Documents Submitted ON-LINE :</p> <p>The online bids will be viewed / downloaded (opened) by the authorized dealing officials of NTPC.</p> <p>Please note that:</p> <ul style="list-style-type: none"> ❖ Bids without requisite EMD will not be opened. ❖ The technical bid of only those bidders, who submit the EMD as stipulated & fulfill any other requirements specified, will be opened and considered for evaluation. <p>Bidders are advised to ensure that the above should reach the addressee (Employer) before the last date & Time for submission of Bid as specified in the NIT / Tender enquiry / Special Purchase Conditions.</p> <p>NTPC shall not be responsible for any loss or delay in transit of these documents.</p> <p><u>Note:</u></p> <ol style="list-style-type: none"> 1. The price bid shall be opened depending upon the type of Bidding as specified in the Special Purchase Conditions (SPC). 2. In case of Single Stage Single envelope bidding, Bid Price Schedule shall be opened on the date and time specified in the NIT. 3. In case of Single Stage Two envelope bidding, Bid Price Schedule of those bidders whose bids are found to be qualified and technically acceptable shall be opened at a later date under intimation to such bidders. 4. In case of provisions of Reverse Auction, the technically acceptable bidders, meeting the qualifying requirements, will be notified the date and time of Reverse Auction.
26.0	DETERMINATION OF RESPONSIVENESS	<p>The Employer will determine whether the Proposals are substantially responsive to the Bidding Document and their proposal is complete.</p> <p>Prior to the detailed evaluation, the Employer will determine whether the bid is of acceptable quality, is generally complete and is substantially responsive to the bidding document. For purpose of this determination, a substantially responsive bid is one that conforms to all the terms, condition and specifications of the bidding documents without material deviations, objections, conditionality or reservations.</p> <p>A material deviation, objection, conditionality or reservation is</p> <ol style="list-style-type: none"> (i) that effects in any substantial way the scope quality or performance of the contract . (ii) that limits in any substantial way inconsistent with the bidding document the Employers right or the successful bidders obligation under the contract or (iii) whose rectification would unfairly affect the competitive position of other bidders who are presenting substantially responsive bids.

		Material deficiencies in the proposal may render the proposal non-responsive and may lead to the rejection of the proposal.
27.0	EVALUATION CRITERIA	The evaluation criteria specified in Special Purchase Conditions (SPC) shall over-ride all other similar related clauses appearing elsewhere in the bidding documents.
28.0	EVALUATION OF BIDS	<p>a) The Employer shall evaluate each Bid that has been determined, up to this stage of the evaluation, to be substantially responsive.</p> <p>b) To evaluate a Bid, NTPC shall only use all the criteria and methodologies defined in this document.</p> <p>c) To evaluate a Bid, NTPC shall consider the following:</p> <ul style="list-style-type: none"> • The bid price as quoted as per Bid Price Schedule • Price adjustment for correction of discrepancy. • Price adjustment due to discounts offered; • Price adjustment due to application of the evaluation criteria.
29.0	DISCREPANCIES IN BID	<p>In case of discrepancies in the bid, the following will be adopted to correct the discrepancies for the purpose of evaluation, where ever Separate Price Break Up is required to be furnished / In case where Prices are asked separately.</p> <p>a) In case of discrepancy between the original & copies of bid, the original bid will be considered as correct.</p> <p>b) In case of discrepancy between unit price in figures and words, the unit price words will be considered as correct.</p> <p>c) In case of discrepancy between unit price and total price, the unit price will be considered as correct.</p> <p>d) In case of discrepancy between unit price and total price, which is obtained by multiplying the unit price and quantity, or between sub-totals and the total price, the unit or subtotal price shall prevail, and the total price shall be corrected accordingly.</p>
30.0	CLARIFICATION OF BIDS	During evaluation, the Employer may, at its discretion, ask any Bidder for a clarification of its Bid. The Employer's request for clarification and the response shall be in writing. No change in the prices or substance of the Bid shall be sought, offered, or permitted.
31.0	CONTACTING THE EMPLOYER	<p>a. Subject to above, no Bidder shall contact the Employer on any matter relating to its bid, from the time of the opening of Bids to the time the contract is awarded.</p> <p>b. Any effort by a Bidder to influence the Employer in the Employer's bid evaluation, bid comparison or contract award decisions may result in rejection of the Bidder's bid.</p>
32.0	EMPLOYER'S RIGHT TO ACCEPT ANY BID AND TO REJECT	The Employer reserves the right to accept or reject any Bid, and to annul the bidding process and reject all Bids at any time prior to Contract award, without thereby incurring any liability to the affected

	ANY OR ALL BIDS	Bidder or Bidders or any obligation to inform the affected Bidder(s) of the grounds for the Employer's action.
33.0	AWARD CRITERIA	The Employer will award the contract to the Bidder whose bid has been determined to be substantially responsive and determined to be qualified to perform the contract satisfactorily, as per criteria detailed in SPC.
34.0	LETTER OF AWARD/PURCHASE ORDER/SERVICE PURCHASE ORDER	Prior to the expiration of the period of bid validity, the Employer will notify the successful Bidder in writing by registered letter or by telefax or email to be confirmed in writing by registered letter, that its bid has been accepted. The Letter of Award/Purchase Order/Service Purchase Order will constitute the formation of the contract.
	SIGNING CONTRACT AGREEMENT OF	At the same time as the Employer notifies the successful Bidder that its bid has been accepted, the Employer will send to the Bidder the Contract Agreement provided in the bidding documents, incorporating all agreements between the parties. Within twenty-eight (28) days of receipt of the Contract Agreement, the successful Bidder / Assignee of foreign bidder (if applicable) shall sign and date the Contract Agreement and return it to the Employer.
35.0	CONSTRUCTION OF CONTRACT	If required, NTPC may place Contracts for Supplies and Services. The award of separate Contracts shall not in any way dilute the responsibility of the Contractor for the successful completion of the Facilities as per Contract Documents and a breach in one Contract shall automatically be construed as a breach of the other Contract(s) which will confer a right on the Employer to terminate the other Contract(s) also at the risk and the cost of the Contractor. The total value of all the Contracts shall be the Total Package value.
36.0	DELIVERY SCHEDULE	The Delivery of the Goods and Completion of the related Services shall be in accordance with the Delivery and Completion Schedule as per SPC.
37.0	CONTRACT PRICE	The Contract Price shall be as specified in the Contract Agreement.
38.0	SCOPE OF SUPPLY	<p>a. The Goods and related Services to be supplied shall be as specified in the technical specification and Price Schedule. The successful bidder shall supply all the Goods and related Services included in the Scope of Supply, as per the Delivery and Completion Schedule specified in the SPC</p> <p>b. Unless otherwise stipulated in the Contract, the Scope of Supply shall include all such items not specifically mentioned in the Contract but that can be reasonably inferred from the Contract as being required for attaining Delivery and Completion of the Goods and related Services as if such items were expressly mentioned in the Contract.</p> <p>c. The Contractor shall ensure that the Goods and related Services comply with the technical specifications and other provisions of</p>

		<p>the Contract.</p> <p>d. The Goods and related Services supplied under this Contract shall conform to the standards mentioned in Technical Specifications and, when no applicable standard is mentioned, the standard shall be equivalent or superior to the official standards whose application is appropriate.</p>
39.0	CONTRACT PERFORMANCE GUARANTEE (CPG)/PBG	<p>a. Within thirty (30) days of issue of Letter of Award/Purchase Order/Service Purchase Order, the Contractor shall furnish the Contract Performance Guarantee for an amount equal to 10% of total package value for due performance of the Contract(s)/Order(s) in any form acceptable to the Employer as mentioned below.</p> <p>CPG should be valid for a period of three months (3 months) beyond the expiry of Contract period.</p> <p>b. CPG may be submitted in any of the following forms :</p> <ul style="list-style-type: none"> • A crossed Demand Draft / Bankers cheque drawn in favour of NTPC Ltd. Payable at (station inviting tender or as per SPC) • An irrevocable Bank Guarantee as per the NTPC standard format from any Nationalized bank / Scheduled Bank as acceptable to NTPC as per list enclosed. <p>c. In case Deed(s) of Joint Undertaking by the Contractor along with his associate(s)/collaborator(s) form part of the Contract, then, unconditional Bank Guarantee(s) from such associate(s) / collaborator(s) towards faithful performance of the Deed(s) of Joint Undertaking for amount(s) specified shall be furnished within twenty eight (28) days after Notification of Award. These Bank Guarantees shall be furnished in the form provided in the section "Forms and Procedures" of the bidding documents and shall be valid till such period as specified in the corresponding format for Deed of Joint Undertaking.</p> <p>d. Failure of the Contractor to submit the above-mentioned Contract Performance Guarantee shall constitute sufficient grounds for the annulment of the award and forfeiture of the Bid Security.</p>
40.0	AUTHORISED REPRESENTATIVE	Any action required or permitted to be taken, and any document required or permitted to be executed, under the Contract by the Employer or the Bidder may be taken or executed by the officials authorized for the purpose.
41.0	INSURANCE	As detailed in SPC
42.0	FREIGHT	As detailed in SPC.
43.0	PACKING	<p>The Bidder shall provide such packing of the Goods as is required to prevent their damage or deterioration during transit to their final destination, handling and storage.</p> <p>The Bidder will be responsible for any loss or damage during transportation, handling and storage due to improper packing.</p>

		All packages should be marked with Purchase Order/Contract no. and date. Each package must contain packing slip and literature, if any.
44.0	INSPECTION AND TESTS	<p>All materials shall be inspected as per provisions of SPC / Technical Specification.</p> <p>For all cases where pre-dispatch inspection is stipulated, materials shall be inspected prior to dispatch by an authorized representative of NTPC for which an advance notice of 15 days shall be given by the Contractor. In such cases no material shall be dispatched without inspection unless specific waiver/exemption is communicated in writing to the Contractor. In all cases necessary test certificates, guarantee certificate in respect of material/equipment performance shall be furnished along with despatch documents. However, the final inspection of material shall be done at our site only and acceptance of materials is subject to such final inspection only.</p>
45.0	WARRANTY	<p>The provision of Warranty shall be as per SPC /Technical Specification.</p> <p>a) The Contractor shall warrant that the Goods shall be free from defects arising from any act or omission of the Contractor or arising from design, materials, and workmanship, under normal use in the conditions.</p> <p>b) The warranty shall remain valid for the period of one year from the date of installation and commissioning or as specified in the Technical Specifications / SPC.</p> <p>c) If having been notified, the Contractor fails to remedy the defect, the Employer may proceed to take within a reasonable period such remedial action as may be necessary, at the Contractor's risk and expense and without prejudice to any other rights which the Employer may have against the Contractor under the Contract.</p>
46.0	PATENTS	<p>All royalties and fees for patents covering material/equipment or processes used in executing the work shall be to the account of the bidder. The Contractor shall satisfy all demands that may be made at any time for such royalties and fees.</p> <p>The Contractor shall hold harmless and indemnify the Employer from and against damage, loss and expenses arising from any claim for infringement of patent, copy right, design and other such rights in existence or to be granted on and application published prior to the completion of this engagement with respect to or arising out of the use or supply of design or any work in accordance with the specifications and plans furnished or recommended by the Contractor/Contractor.</p> <p>The Contractor shall promptly notify the Employer in writing if the Contractor has or has acquired knowledge of any patent under which claim or suit for infringement could reasonably be brought because of the use by the Employer of any information, recommendation or specifications, services rendered by the Contractor/Contractor.</p> <p>The Contractor, in such case, shall furnish at its own cost make and furnish to the Employer alternative specifications or recommendations to avoid the same and without putting the Employer to any additional cost.</p> <p>The Employer shall indemnify and hold harmless the Contractor and its</p>

		employees, officers and Sub-contractors from and against any and all suits, actions or administrative proceedings, claims, demands, losses, damages, costs, and expenses of whatsoever nature, including attorney's fees and expenses, which the Contractor may suffer as a result of any infringement or alleged infringement of any patent, utility model, registered design, trademark, copyright or other intellectual property right registered or otherwise existing at the date of the Contract arising out of or in connection with any design, data, drawing, specification, or other documents or materials provided or designed by or on behalf of the Employer
47.0	INDEMNIFICATION	<p>The Contractor shall, at its own expense, defend and indemnify the Employer against all third party claims of infringement of Intellectual Property Rights, including patent, trade mark, copy right, trade secret or industrial design rules arising from use of the products or any part thereof.</p> <p>The Contractor shall expeditiously extinguish any such claims and shall have full rights to defend itself there from. The Employer shall not pay any compensation to a third party resulting from such infringement and the Contractor shall be fully responsible for the same, including all expenses and court and legal fees.</p> <p>The Employer will give notice to the Contractor of any such claim without delay, shall provide reasonable assistance to the Contractor/Contractor in disposing of the claim, and shall at no time admit any liability for or express any intent to settle the claim.</p> <p>Final payment to the Contractor by the Employer will not be made while any such suit or claim remains unsettled.</p>
48.0	REMOVAL OF REJECTED GOODS AND REPLACEMENT	<p>a) If upon delivery, whether inspected and approved earlier or otherwise, the material/equipment is not in conformity with the specifications, the same shall be rejected by the Employer or his duly authorised representative and notification to this effect will be issued to the Contractor within 30 days from the date of receipt of the material at site.</p> <p>b) The Contractor shall arrange for removal of the rejected item(s) within 15 days from the date of notification. In the event , the Contractor fails to lift the materials within the said 15 days, the Employer shall be at liberty to dispose of such rejected item(s) in any manner as he may think fit. All expenses shall be recoverable from the Contractor.</p>
49.0	MODIFICATION OF CONTRACT	Modification of the terms and conditions of the Contract, including any modification of the Scope of the Services or of the Contract price may only be made by written agreement between the Parties.
50.0	LIQUIDATED DAMAGES	The timely delivery of the material is the essence of the contract. In the event of Contractor failure to deliver the material of acceptable quality within the stipulated delivery period, the liquidated damages are payable by the Contractor @ 0.5% (one half of one percent) per week of delay or part thereof, of the unexecuted order value. However, the total liability of the Bidder under this clause shall not exceed 5% of the Contract value as awarded.

51.0	FORCE MAJEURE	<p>(a) "Force Majeure" shall mean any event beyond the reasonable control of the Employer or the Contractor, as the case may be, and which is unavoidable notwithstanding the reasonable care of the party affected and which substantially affect the performance of the Contract.</p> <p>Notwithstanding the generality of the above, the following events shall be termed as Force Majeure events in respect of the Order</p> <ul style="list-style-type: none"> (i) terrorist acts, (ii) confiscation, nationalization, mobilization, commandeering or requisition by or under the order of any government or de jure or de facto authority or ruler or any other act of failure to act of any local state or national government authority, (iii) national/sectoral/illegal strike, sabotage, lockout embargo, import restriction, port congestion, lack of usual means of public transportation and communication, industrial dispute, shipwreck, epidemics, quarantine and plague. <p>(b) If either party is prevented, hindered or delayed from or in performing any of its obligations under the Contract by an event of Force Majeure, then it shall notify the other in writing of the occurrence of such event and the circumstances there of within fourteen (14) days after the occurrence of such event.</p> <p>(c) The party who has given such notice shall be excused from the performance or punctual performance of its obligations under the Contract for so long as the relevant event of Force Majeure continues and to the extent that such party's performance is prevented, hindered or delayed. The Time for Completion shall be extended by a reasonable time.</p> <p>(d) The party or parties affected by the event of Force Majeure shall use reasonable efforts to mitigate the effect there of upon its or their performance of the Contract and to fulfill its or their obligations under the Contract, but without prejudice to either parties' right to terminate the contract under clause (f) here under.</p> <p>(e) Delay or nonperformance by either party hereto caused by the occurrence of any event of Force Majeure shall not</p> <ul style="list-style-type: none"> i. constitute a default or breach of the Contract ii. give rise to any claim for damages or additional cost or expense occasioned thereby <p style="padding-left: 40px;">If and to the extent that such delay or non performance is caused by the occurrence of an event of Force Majeure.</p> <p>(f) If the performance of the Contract is substantially prevented, hindered or delayed for a single period of more than sixty (60) days or an aggregate period of more than one hundred and twenty (120) days on account of one or more events of Force Majeure during the currency of the Contract, the parties will attempt to develop a mutually satisfactory solution, failing which the dispute shall be resolved in accordance with Clause 56 (SETTLEMENT OF</p>
------	---------------	---

		DISPUTES) (g) Notwithstanding clause (e) above, Force Majeure shall not apply to any obligation of the Employer to make payments to the Contractor herein.
52.0	NO BREACH OF CONTRACT	The failure of a party to fulfill any of its obligations under the Contract shall not be considered to be a breach of or default under the Contract in so far as such inability arises from an event of Force Majeure, provided that the Party affected by such an event (a) has taken all reasonable precautions, due care and reasonable alternative measures in order to carry out the terms and conditions of this Contract and (b) has informed the other Party as soon as possible about the occurrence of such an event.
53.0	OBLIGATIONS OF THE BIDDER	The Bidder shall perform the Services and carry out their obligations with all due diligence, efficiency, and economy, in accordance with generally accepted professional techniques and practices, and shall observe sound management practices, and employ appropriate advance technology and safe methods. The Bidder shall always act, in respect of any matter relating to this Contract or to the Services, as faithful advisers to the Employer and shall at all times support and safeguard the Employer's legitimate interests in any dealings with Sub-bidder or third parties.
54.0	RISK PURCHASE	In the event of Contractors failure to supply the material of acceptable quality in scheduled delivery period, NTPC reserves the right to procure the materials from any other source at the Contractors risk and cost and the difference in cost shall be borne by the Contractor. Further, NTPC shall retain the right of forfeiture of CPG and or any other action as deemed fit.
55.0	SETTLEMENT OF DISPUTES	
55.1	Mutual Consultation If any dispute of any kind whatsoever shall arise between the Employer and the Contractor in connection with or arising out of the Contract, including without prejudice to the generality of the foregoing, any question regarding its existence, validity or termination, or the execution of the Facilities, whether during the progress of the Facilities or after their completion and whether before or after the termination, abandonment or breach of the Contract, the parties shall seek to resolve any such dispute or difference by mutual consultation. If the parties fail to resolve such a dispute or difference by mutual consultation, then the dispute may be settled through Expert Settlement Council/Arbitration.	
55.1.1	Resolution of Dispute through Conciliation Where the disputed amount is within Rs 250 crores (to be arrived at considering the claim and counter claim of the parties to the dispute) and in case the parties fail to resolve such a dispute or difference by mutual consultation, the dispute may be referred to Conciliation.	
55.1.2	Invitation for	(i) A party shall notify the other party in writing about such a dispute it wishes to refer for conciliation within a period of 30

	Conciliation	<p>days from the date of failure to resolve the dispute through mutual consultation. Such Invitation for conciliation shall contain sufficient information as to the dispute to enable the other party to be fully informed as to the nature of the dispute, amount of the monetary claim, if any, and apparent cause of action.</p> <p>(ii) Upon acceptance of the invitation to conciliate, the other party shall submit its counter claim, if any, within a period of 30 days from the date of the invitation to conciliate. If the other party rejects the invitation or if disputed amount exceeds Rs. 250 crores, there will be no conciliation proceedings.</p> <p>(iii) If the party initiating conciliation does not receive a reply within thirty days from the date it sends the invitation, or within such other period of time as specified in the invitation, it shall treat this as a rejection of the invitation to conciliate from the other party.</p>
55.1.3	Conciliation	<p>(i) Where Invitation for conciliation has been furnished under GPC sub clause 55.1.2, the parties shall attempt to settle such dispute through Expert Settlement Council (ESC) which shall be constituted by CMD, NTPC.</p> <p>(ii) ESC will be formed from experts comprising three members from the panel of conciliators maintained by NTPC. However, there will be single member ESC for disputes involving claim and counter claim (if any) up to Rs. 1 crore. CMD, NTPC will have authority to reconstitute an ESC to fill any vacancy.</p> <p>(iii) The eligible persons for consideration for empanelment in the panel of conciliators shall be amongst Retired Civil Servants of Govt. of India not below the rank of Additional Secretary, Retired Judges, Retired Directors/ Chairman of any Maharatna/Navratna company in India other than NTPC Ltd, Retired Independent Directors who have served on the Board of any Maharatna/ Navratna company in India other than NTPC Ltd and Independent experts in their respective fields preferably registered with the Indian Council of Arbitration or Delhi International Arbitration Centre or Federation of Indian Chambers of Commerce and Industry or SCOPE Arbitration Forum.</p>
55.2	Proceedings before ESC	<p>(i) The claimant shall submit its statement of claims along with relevant documents to ESC members, and to the party(s) indicated in the appointment letter within 30 days of the issue of the appointment letter. The respondent shall file its reply and counter claim (if any) within 30 days of the receipt of the statement of claims. Parties may file their rejoinder/additional documents, if any in support of their claim/counterclaim within next 15 days. No documents shall be allowed thereafter, except with the permission of ESC.</p>

55.2.1		<p>(ii) The parties shall file their claim and counterclaim in the following format</p> <ol style="list-style-type: none"> a. Chronology of the dispute b. Brief of the contract c. Brief history of the dispute d. Issues <table border="1" data-bbox="644 416 1369 636"> <thead> <tr> <th data-bbox="644 416 727 524">Sl. No.</th> <th data-bbox="727 416 967 524">Description of Claims/ Counter claims</th> <th data-bbox="967 416 1206 524">Amount (in foreign currency/INR)</th> <th data-bbox="1206 416 1369 524">Relevant Contract Clause</th> </tr> </thead> <tbody> <tr> <td data-bbox="644 524 727 562"></td> <td data-bbox="727 524 967 562"></td> <td data-bbox="967 524 1206 562"></td> <td data-bbox="1206 524 1369 562"></td> </tr> <tr> <td data-bbox="644 562 727 600"></td> <td data-bbox="727 562 967 600"></td> <td data-bbox="967 562 1206 600"></td> <td data-bbox="1206 562 1369 600"></td> </tr> <tr> <td data-bbox="644 600 727 636"></td> <td data-bbox="727 600 967 636"></td> <td data-bbox="967 600 1206 636"></td> <td data-bbox="1206 600 1369 636"></td> </tr> </tbody> </table> <ol style="list-style-type: none"> e. Details of Claim(s)/Counter Claim(s) f. Basis/Ground of claim(s)/counter claim(s) along with relevant clause of contract. <p>Statement of claims shall be restricted to maximum limit of 20 pages.</p>	Sl. No.	Description of Claims/ Counter claims	Amount (in foreign currency/INR)	Relevant Contract Clause												
Sl. No.	Description of Claims/ Counter claims	Amount (in foreign currency/INR)	Relevant Contract Clause															
55.2.2		<p>(iii) In case of 3 members ESC, 2 members will constitute a valid quorum and the meeting can take place to proceed in the matter after seeking consent from the member who is not available. However, ESC recommendations will be signed by all the members.</p>																
55.2.3		<p>(iv) The parties shall be represented by their in house employees. No party shall be allowed to bring any advocate or outside consultant/advisor/agent to contest on their behalf. Ex officers of NTPC who have handled the disputed matter in any capacity shall not be allowed to attend and present the case before ESC on behalf of contractor. However, ex-employees of parties may represent their respective organizations. Parties shall not claim any interest on claims/counter-claims from the date of notice invoking conciliation till execution of settlement agreement, if so arrived. In case, parties are unable to reach a settlement, no interest shall be claimed by either party for the period from the date of notice invoking conciliation till the date of ESC recommendations and 30 days thereafter in any further proceeding.</p>																
		<p>(v) ESC will conclude its proceedings in maximum 10 meetings, and give its recommendations within 90 days of its first meeting. ESC will give its recommendations to both the parties recommending possible terms of settlement. CMD, NTPC may extend the time/number of meetings, in exceptional cases, if ESC requests for the same with sufficient reasons.</p>																
		<p>(vi) Depending upon the location of ESC members and the parties, the venue of the ESC meeting shall be either Delhi/Mumbai/Kolkata/Chennai or any other city whichever is</p>																

		most economical from the point of view of travel and stay etc. All the expenditure incurred in ESC proceedings shall be shared by the parties in equal proportion.																														
55.2.4	Fees & Facilities to the Members of the ESC	<p>The cost of conciliation proceedings including but not limited to fees for Conciliator, Airfare, Local transport, Accommodation, cost towards conference facility etc. shall be as provided herein below:</p> <table border="1"> <thead> <tr> <th>Sl</th> <th>Fees/ Facility</th> <th>Entitlement</th> </tr> </thead> <tbody> <tr> <td>1</td> <td>Fees</td> <td>As paid to NTPC Independent Directors [Presently Rs. 20,000 per meeting]. In addition, each conciliator to be paid Rs 10,000 for attending meeting to authenticate the settlement agreement. - max. of Rs. 2,10,000 per case per Conciliator.</td> </tr> <tr> <td>2</td> <td>Secretarial</td> <td>Rs. 10,000 lump sum (to 1 member)</td> </tr> <tr> <td>3</td> <td>Transportation in the city of the</td> <td>Car as per entitlement or Rs. 2,000 per day</td> </tr> <tr> <td>4</td> <td>Venue for</td> <td>NTPC conference rooms</td> </tr> <tr> <td colspan="3">Facilities to be provided to the out -stationed member</td> </tr> <tr> <td>5</td> <td>Travel from the city of residence to the city of meeting</td> <td>As per entitlement of Independent Directors. Executive class air tickets/ first class AC train tickets/ Luxury car/ reimbursement of actual fare. However, entitlement of air travel by Business class shall be subject to austerity measures, if any, ordered by Govt. of India.</td> </tr> <tr> <td>6</td> <td>Transport to and fro airport/railway station in the city of residence</td> <td>Car as per entitlement or Rs. 3,000</td> </tr> <tr> <td>7</td> <td>Stay for out stationed</td> <td>As per entitlement of Independent Directors.</td> </tr> <tr> <td>8</td> <td>Transport in the city of meeting</td> <td>Car as per entitlement or Rs. 2000 per day</td> </tr> </tbody> </table> <p>Aforesaid fees is subject to revision by NTPC from time to time and subject to government guidelines on austerity measures, if any. All the expenditure incurred in the ESC proceedings shall be shared by the parties in equal proportions. The Parties shall maintain the</p>	Sl	Fees/ Facility	Entitlement	1	Fees	As paid to NTPC Independent Directors [Presently Rs. 20,000 per meeting]. In addition, each conciliator to be paid Rs 10,000 for attending meeting to authenticate the settlement agreement. - max. of Rs. 2,10,000 per case per Conciliator.	2	Secretarial	Rs. 10,000 lump sum (to 1 member)	3	Transportation in the city of the	Car as per entitlement or Rs. 2,000 per day	4	Venue for	NTPC conference rooms	Facilities to be provided to the out -stationed member			5	Travel from the city of residence to the city of meeting	As per entitlement of Independent Directors. Executive class air tickets/ first class AC train tickets/ Luxury car/ reimbursement of actual fare. However, entitlement of air travel by Business class shall be subject to austerity measures, if any, ordered by Govt. of India.	6	Transport to and fro airport/railway station in the city of residence	Car as per entitlement or Rs. 3,000	7	Stay for out stationed	As per entitlement of Independent Directors.	8	Transport in the city of meeting	Car as per entitlement or Rs. 2000 per day
Sl	Fees/ Facility	Entitlement																														
1	Fees	As paid to NTPC Independent Directors [Presently Rs. 20,000 per meeting]. In addition, each conciliator to be paid Rs 10,000 for attending meeting to authenticate the settlement agreement. - max. of Rs. 2,10,000 per case per Conciliator.																														
2	Secretarial	Rs. 10,000 lump sum (to 1 member)																														
3	Transportation in the city of the	Car as per entitlement or Rs. 2,000 per day																														
4	Venue for	NTPC conference rooms																														
Facilities to be provided to the out -stationed member																																
5	Travel from the city of residence to the city of meeting	As per entitlement of Independent Directors. Executive class air tickets/ first class AC train tickets/ Luxury car/ reimbursement of actual fare. However, entitlement of air travel by Business class shall be subject to austerity measures, if any, ordered by Govt. of India.																														
6	Transport to and fro airport/railway station in the city of residence	Car as per entitlement or Rs. 3,000																														
7	Stay for out stationed	As per entitlement of Independent Directors.																														
8	Transport in the city of meeting	Car as per entitlement or Rs. 2000 per day																														

		account of expenditure and present to the other for the purpose of sharing on conclusion of the ESC proceedings
55.2.5	If decision of NTPC is acceptable to the contractor, a Settlement Agreement under section 73 of the Arbitration and Conciliation Act 1996 will be signed within 15 days of contractor's acceptance and same shall be authenticated by all the ESC members. Parties are free to terminate conciliation proceedings at any stage as provided under the Arbitration and Conciliation Act 1996.	
55.2.6	The parties shall keep confidential all matters relating to the conciliation proceedings. Parties shall not rely upon them as evidence in arbitration proceedings or court proceedings.	
55.3	Arbitration	
55.3.1	In case the parties fail to settle the dispute through the process of mutual consultation and/or conciliation as per GPC Sub-Clause 55.1 & 55.2 above, either party may give a notice to the other party, of its intention to commence arbitration, as hereinafter provided, as to the matter in dispute, and no arbitration in respect of this matter may be commenced unless such notice is given. Such notice of intention to commence arbitration shall be given within a period of thirty (30) days from the date of failure to settle the matter through mutual consultation or thirty (30) days from the date of termination of ESC proceedings (applicable only in case where ESC has been constituted).	
55.3.2	Any dispute in respect of which a notice of intention to commence arbitration has been given, in accordance with Sub-Clause 55.3.1 above, shall be finally settled by arbitration. Arbitration may be commenced prior to or after completion of the Package/Order.	
55.3.2.1	In case of Purchase Orders/Service Orders placed on firms, other than Public Sector Enterprises	
	Any dispute or difference submitted by a party to arbitration shall be heard by an arbitration tribunal consisting of three arbitrators, in accordance with the provisions set forth below:	
	i.	The Employer and the Supplier shall each appoint one arbitrator, and these two arbitrators shall jointly appoint a third arbitrator, who shall chair the arbitration panel. If the two arbitrators do not succeed in appointing a third arbitrator within twenty eight (28) days after the latter of the two arbitrators has been appointed, the third arbitrator shall, at the request of either party, appointed by the Appointing Authority for arbitrator as under a) President, Institution of Engineers in case of an Indian Contractor. b) President, International Chambers of Commerce, Paris in case of a Foreign Contractor.
	ii.	If one party fails to appoint its arbitrator within forty-two (42) days after the other party has named its arbitrator, the party which has named an arbitrator may request the Appointing Authority as mentioned in GPC Clause 55.3.2.1 (i) to appoint the second arbitrator.
	iii.	If for any reason an arbitrator is unable to perform its function, the mandate of the Arbitrator shall terminate in accordance with the provisions of applicable laws as mentioned in GPC Clause 13.0 (Governing Law) and a substitute shall be appointed in

		the same manner as the original arbitrator.												
	iv.	<p>Arbitration proceedings shall be conducted</p> <p>(i) in accordance with the rules of procedure mention as under,</p> <p>(a) In case of a foreign contractor/ collaborator/associate of the contractor, the arbitration proceeding shall be conducted in accordance with the United Nations Commission on International Trade Law (UNCITRAL) Arbitration Rules of 1976.</p> <p>(b) In case of an Indian Contractor, the arbitration proceedings shall be conducted in accordance with Indian Arbitration and Conciliation Act 1996.</p> <p>(ii) the Place for Arbitration shall be: New Delhi, India. and</p> <p>(iii) in the language in which this Contract has been executed.</p>												
	v.	The decision of the majority of the arbitrators (or of the third arbitrator chairing the arbitration tribunal, if there is no such majority) shall be final and binding and shall be enforceable in any court of competent jurisdiction as a decree of the court. The parties thereby waive any objections to or claims of immunity from such enforcement.												
	vi.	The arbitrator(s) shall give reasoned award.												
	vii.	(A) Arbitration Fee												
		<p>(I) The Arbitrators shall be paid fees at the following rates:</p> <table border="1"> <thead> <tr> <th>Amount of Claims and Counter Claims (excluding interest)</th> <th>Lump sum fees (including fees for study of pleadings, case material, writing of the award, secretarial charges etc.) payable to each arbitrator (to be shared equally by the parties)</th> </tr> </thead> <tbody> <tr> <td>Up to Rs.50 lakhs</td> <td>Rs. 10,000/- per meeting subject to a ceiling of Rs. 1,00,000/-.</td> </tr> <tr> <td>Above Rs.50 lakhs to Rs.1 Crore</td> <td>Rs.1,35,000/- plus Rs.1,800/- per lakh or a part there of subject to a ceiling of Rs. 2,25,000/-.</td> </tr> <tr> <td>Above Rs.1 crore and up to Rs.5 Crore</td> <td>Rs.2,25,000/- plus Rs.33,750/- per crore or a part thereof subject to a ceiling of Rs.3,60,000/-.</td> </tr> <tr> <td>Above Rs. 5 Crore and up to Rs.10 Crore</td> <td>Rs.3,60,000/- plus Rs.22,500/- per crore or a part thereof subject to a ceiling of Rs. 4,72,500/-.</td> </tr> <tr> <td>Above Rs.10 Crore</td> <td>Rs.4,72,500 plus Rs.18,000/- per crore or part thereof subject to a ceiling of Rs. 10,00,000/-.</td> </tr> </tbody> </table> <p>If the claim is in foreign currency, the SBI Bills Selling Exchange rate prevailing on the date of claim shall be used for the purpose of converting the claim in</p>	Amount of Claims and Counter Claims (excluding interest)	Lump sum fees (including fees for study of pleadings, case material, writing of the award, secretarial charges etc.) payable to each arbitrator (to be shared equally by the parties)	Up to Rs.50 lakhs	Rs. 10,000/- per meeting subject to a ceiling of Rs. 1,00,000/-.	Above Rs.50 lakhs to Rs.1 Crore	Rs.1,35,000/- plus Rs.1,800/- per lakh or a part there of subject to a ceiling of Rs. 2,25,000/-.	Above Rs.1 crore and up to Rs.5 Crore	Rs.2,25,000/- plus Rs.33,750/- per crore or a part thereof subject to a ceiling of Rs.3,60,000/-.	Above Rs. 5 Crore and up to Rs.10 Crore	Rs.3,60,000/- plus Rs.22,500/- per crore or a part thereof subject to a ceiling of Rs. 4,72,500/-.	Above Rs.10 Crore	Rs.4,72,500 plus Rs.18,000/- per crore or part thereof subject to a ceiling of Rs. 10,00,000/-.
Amount of Claims and Counter Claims (excluding interest)	Lump sum fees (including fees for study of pleadings, case material, writing of the award, secretarial charges etc.) payable to each arbitrator (to be shared equally by the parties)													
Up to Rs.50 lakhs	Rs. 10,000/- per meeting subject to a ceiling of Rs. 1,00,000/-.													
Above Rs.50 lakhs to Rs.1 Crore	Rs.1,35,000/- plus Rs.1,800/- per lakh or a part there of subject to a ceiling of Rs. 2,25,000/-.													
Above Rs.1 crore and up to Rs.5 Crore	Rs.2,25,000/- plus Rs.33,750/- per crore or a part thereof subject to a ceiling of Rs.3,60,000/-.													
Above Rs. 5 Crore and up to Rs.10 Crore	Rs.3,60,000/- plus Rs.22,500/- per crore or a part thereof subject to a ceiling of Rs. 4,72,500/-.													
Above Rs.10 Crore	Rs.4,72,500 plus Rs.18,000/- per crore or part thereof subject to a ceiling of Rs. 10,00,000/-.													

		<p>Indian Rupee which may be used for determining the arbitration fee as brought out above.</p> <p>(II) If after commencement of the Arbitration proceedings, the parties agree to settle the dispute mutually or refer the dispute to conciliation, the arbitrators shall put the proceedings in abeyance until such period as requested by the parties. Where the proceedings are put in abeyance or terminated on account of mutual settlement of dispute by the parties, the fees payable to the arbitrators shall be determined as under:</p> <p>(i) 20% of the fees if the claimant has not submitted statement of claim (ii) 40% of the fees if the pleadings are complete (iii) 60% of the fees if the hearing has commenced (iv) 80% of the fees if the hearing is concluded but the award is yet to be passed.</p> <p>(III) Each party shall pay its share of arbitrator’s fees in stages as under:</p> <p>(i) 20% of the fees on filing of reply to the statement of claim (ii) 40 % of the fees on completion of pleadings (iii) 20% of the fees on conclusion of the final hearing (iv) 20% at the time when award is given to the parties</p> <p>(IV) Each party shall be responsible to make arrangements for the travel and stay etc. of the arbitrator appointed by it. As regards the Presiding Arbitrator, the expenses incurred on his travel/stay shall be shared equally by the parties.</p> <p>(V) The parties agree that they shall appoint only those persons as arbitrators who accept the conditions of arbitration clause, including the fees schedule provided herein. No person shall be appointed as arbitrator or presiding arbitrator who does not accept the conditions of arbitration clause including the fee schedule provided hereinbefore.</p> <p>(B) Arbitration Period</p> <p>The arbitrators shall make and publish the award within time stipulated as under:</p> <table border="1" data-bbox="475 1406 1391 1686"> <thead> <tr> <th>Amount of Claims and Counter Claims (excluding interest)</th> <th>Period for making and publishing of the award (counted from the date of first meeting of the arbitrators)</th> </tr> </thead> <tbody> <tr> <td>Up to Rs. 5 Crore</td> <td>Within 8 months</td> </tr> <tr> <td>Above Rs. 5 Crore</td> <td>Within 12 months</td> </tr> </tbody> </table> <p>The above time limit can be extended by the arbitrators, for reasons to be recorded in writing, with the consent of the parties.</p>	Amount of Claims and Counter Claims (excluding interest)	Period for making and publishing of the award (counted from the date of first meeting of the arbitrators)	Up to Rs. 5 Crore	Within 8 months	Above Rs. 5 Crore	Within 12 months
Amount of Claims and Counter Claims (excluding interest)	Period for making and publishing of the award (counted from the date of first meeting of the arbitrators)							
Up to Rs. 5 Crore	Within 8 months							
Above Rs. 5 Crore	Within 12 months							
55.3.2.2		<p>In case of Purchase Order/Service Order placed on Public Sector Enterprise (but not a State Govt. Undertaking or Joint Sector Undertaking which is not a subsidiary of Central Govt. Undertaking)</p>						
		<p>In the event of any dispute or difference relating to the interpretation and application of the provisions of the contracts, such dispute or difference shall be referred by either party for</p>						

	<p>Arbitration to the sole Arbitrator in the Department of Public Enterprises to be nominated by the Secretary to the Government of India in-charge of the Department of Public Enterprises. The Arbitration and Conciliation Act, 1996 shall not be applicable to arbitration under this clause. The award of the Arbitrator shall be binding upon the parties to the dispute, provided, however, any party aggrieved by such award may make a further reference for setting aside or revision of the award to the Law Secretary, Department of Legal Affairs, Ministry of Law & Justice, Government of India. Upon such reference the dispute shall be decided by the Law Secretary or the Special Secretary/Additional Secretary, when so authorized by the Law Secretary, whose decision shall bind the Parties finally and conclusively. The Parties to the dispute will share equally the cost of arbitration as intimated by the Arbitrator.</p> <p>(DPE O.M. No. DPE/4(1)/2011-DPE(PMA)-GL dated 12th June 2013)</p>	
55.4	<p>Notwithstanding any reference to the arbitration herein,</p> <p>(a) the parties shall continue to perform their respective obligations under the Contract unless they otherwise agree.</p> <p>(b) the Employer shall pay the Contractor any monies due to the Supplier.</p>	
56.0	NOTICES	<p>Any notice, request, or consent sought pursuant to the tender shall be in writing and shall be deemed to have been made when delivered in person to an authorized representative of the Party to whom the communication is addressed, or when sent by speed post, telex, telegram, or facsimile to such Party i.e. Employer or Bidder.</p>
57.0	TERMINATION	<p>The Employer may terminate the Contract, by not less than thirty(30) days' written notice of termination to the Contractor , to be given after the occurrence of any of the events specified in paragraphs(a) to (d) of this Clause and sixty(60) days' in the case of the event referred to in (e) below :</p> <p>(a) if the Contractor does not remedy a failure in the performance of their obligations under the Contract, within thirty (30) days after being notified or within any further period as the Employer may have subsequently approved in writing;</p> <p>(b) if the Contractor becomes insolvent or bankrupt;</p> <p>(c) if as a result of Force Majeure, the Contractor is unable to perform a material portion of the Services for a period of not less than sixty(60) days; or</p> <p>(d) if the Contractor, in the judgment of the Employer has engaged in corrupt or fraudulent practices in competing or in executing the Contract.</p> <p>For the purpose of this clause:</p> <p>“Corrupt Practice” means the offering, giving, receiving or soliciting of any thing of value to influence the action of a public official in the selection process or in contract execution.</p> <p>“Fraudulent Practice” means a misrepresentation of facts in order to influence a selection process or the execution of a contract to the detriment of the Employer.</p> <p>(e) if the Employer, at its sole discretion, decides to terminate this Contract.</p> <p>In event of termination of Contract under GPC sub Clause 58 above,</p>

		the Employer shall pay to the Contractor/Contractor the Contract Price, properly attributable to the works/supplies executed by the Contractor/Contractor as on the date of termination.
58.0	TAXES & DUTIES	<p>i. Except as otherwise specifically provided in the Contract, the Contractor/Contractor shall bear and pay all taxes, duties, levies and charges assessed on the Contractor/Contractor, its Sub-contractor or their employees by all municipal, state or national government authorities in connection with the Facilities in and outside of the country where the Site is located.</p> <p>ii. Notwithstanding provisions of SPC clause 58.0 (i) above, the Employer shall bear and promptly pay/reimburse all Customs and Import duties as well as other local taxes like e.g. Value Added Tax (VAT), Octroi (if applicable), imposed on the Software(s), Hardware and other items specified in the on-line BPS and that are to be incorporated in the solution, by the law of the country where the Site is located. The Employer shall also bear and pay/reimburse to the Contractor/Contractor, Excise Duty, Sales (but not the surcharge in lieu of Sales Tax), Octroi (if applicable) in respect of direct transactions between the Employer and Contractor/Contractor, imposed on the Software and other items in the on-line BPS, by the law of country where the site is located. Bidder is required to quote the applicable rate of VAT, Service tax, other taxes and duties applicable in India in the on-line BPS. Further is to be enclosed in SRM – ‘Unpriced Bid’ tab under ‘Attachment’ link.</p> <p>Employer will NOT issue any sales tax declaration form(s) in order to get the benefit of any concession in the rate of sales tax.</p> <p>Entry tax on the hardware and software shall be paid by the Employer directly to the Tax Authorities and entry tax as per rates applicable as on seven days prior to the date of opening of Techno-commercial bid shall be deducted from the payments due to the Contractor/Contractor. In case of any upward variation in rates between those applicable seven days prior to the date of bid submission and date of entry of goods and payment of Entry Tax by NTPC, the deduction from Contractor’s bill will be limited to the amount being worked out at the rates of Entry Tax as applicable seven days prior to the submission of bid. In case of downward variation, the contract price will be adjusted for such downward variation in rates of Entry Tax between those applicable seven days prior to bid opening and the date of entry of good and payment of Entry Tax by NTPC.</p> <p>All taxes, duties and levies on Works Contract, if any, shall be to the Contractor/Contractor’s account and no separate claim in this regard will be entertained by the Employer.</p> <p>All taxes, duties and levies in respect of local transportation & insurance, port clearance, port charges, other local costs incidental to delivery of software(s) implementation, testing and commissioning shall be to the Contractor/Contractor’s account and no separate claim in this regard will be entertained</p>

		<p>by the Employer.</p> <p>Incidence of Service Tax & Cess on any component of the bid price shall be to the Contractor/Contractor's account and included in the Contract Price as applicable on seven (7) days prior to the date set for price bid submission. The rate of tax be specified in the bid. However, financial implication if any on account of any change in the rate of service tax as applicable for direct transactions between the Employer and the Contractor/Contractor shall be to Employer's account.</p> <p>Bidder shall indicate the tax including the Entry tax seven (7) days prior to last date of Bid Submission.</p> <p>If any tax exemptions, reductions, allowances or privileges are available to the Contractor/Contractor in the country where the Site is located, the Employer shall use its best endeavours to enable the Contractor/Contractor to benefit from any such tax savings to the maximum allowable extent.</p> <p>Notwithstanding aforesaid, in the event of withdrawal of Exemptions/ Benefits as per the extant Policy/Notification of Govt of India, the impact of differential duty/tax liability shall be adjusted in Contract Price subject to documentary evidence.</p> <p>iii. The Employer shall be authorized to deduct any tax as applicable from the Bidder.</p> <p>iv. Income Tax :</p> <p>As per Indian Income Tax Act & Rules, Employer is required to deduct Income Tax at source from all the payments to be made to Non resident/Foreign Contractor/Contractor. For this purpose, the Contractor/Contractor shall be required to either furnish</p> <p>a) the certificate from Indian Tax Authority or b) Ruling from "the Authority for Advance Ruling (AAR)" determining the applicable rate of Income tax in India before release of first payment.</p> <p>The credit of TDS shall be given by the Income Tax Department as per details furnished by the Employer against PAN of the Contractor/Contractor. The Contractor/Contractor will be required to submit PAN details to the Engr-in-charge/Project Manager before the submission of the first bill. Further, TDS certificate in line with the provisions of the Income Tax Act 1961 will be issued.</p> <p>v. Octroi shall be reimbursed at actual and shall not be considered for bid evaluation.</p> <p>vi. Bidders are requested to provide the breakup of taxes in the Bid Price Schedule prevailing at seven (7) days prior to the last date of bid submission.</p> <p>vii. For the purpose of the contract it is agreed that the contract price specified in the on-line Price Schedule is based on the taxes duties and charges prevailing at seven (7) days prior to the last</p>
--	--	--

		<p>date of bid submission.</p> <p>viii. In case Bidder has indicated (Zero) tax same shall be treated as included in the base price. The break up of applicable rate of taxes is to furnished in the Technical Bid.</p> <p>ix. If any rates of tax are increased or decreased, a new tax is introduced, an existing tax is abolished, or any change in interpretation or application of any tax occurs in the course of the performance of contract, which was or will be assessed on the bidder in connection with performance of the contract, an equitable adjustment of the contract price shall be made to fully take into account any such change by addition to the contract price or deduction there from as the case may be.</p>
59.0	ENTRY TAX	<p>i. Bid price shall also be inclusive of any liability of Entry Tax applicable on the items / services / Equipments quoted by the bidder at the rates prevailing as on seven (7) days prior to the last date of Bid Submission.</p> <p>ii. Entry tax as applicable on the equipments as specified in the bid shall be paid by the Employer directly to the tax authorities and the entry tax as per rates applicable as on Seven (7) days prior to the last date of Bid Submission shall be deducted from the payments due to the Contractor/Contractor.</p> <p>ii. Notwithstanding the above in case of any upward variation in rates of Entry tax between those applicable seven (7) days prior to the last date of Bid Submission & the date of entry of goods and payment of entry tax by the Employer, the deduction from Contractor/Contractors bills will be limited to the amount being worked out at the rates of Entry Tax as applicable, seven (7) days prior to the last date of Bid Submission.</p> <p>v. In case of down ward variation the contract price will be adjusted for such down ward variation in rates of Entry tax between those applicable, seven (7) days prior to the last date of Bid Submission and the date of entry of goods & payment of entry tax by Employer.</p>
60.0	ROAD PERMIT	<p>The road permit shall be issued by NTPC, wherever required and the acknowledged copy of same is to be returned by the Contractor within 7 days from the date of completion of supplies to the sales tax authorities.</p> <p>All liability on account of non-submission, loss, misplacement shall solely rest with the bidder. The final payment will be processed only after receipts of counterfoil of the relevant forms are received by the NTPC / Engineer in charge.</p>
61.0	TAX DEDUCTION AT SOURCE	Tax deduction at source shall be governed as per prevailing rules.
62.0	PAYMENTS TO THE SUCCESSFUL BIDDER	Payment will be made to the account of the successful bidder as per the payment terms mentioned in the PO / LOA based on the certification of Engineer. The payments shall be made after the conditions listed for such payment have been met, and the successful

		<p>bidder has submitted an invoice to the Employer specifying the amount due.</p> <p>Payment shall be released within 30 days of receipt, acceptance of materials and submission of invoice in all respect as per Payment terms mentioned in SPC or as mentioned in the PO / LOA.</p> <p>Our Standard Payment terms are as under:</p> <p>For Supplies: The payment would be made within 30 days of receipt and acceptance of materials.</p> <p>For AMC/CMS: The Annual Maintenance Service Contract wherever applicable, shall commence after completion of the warranty period. The payment of the annual maintenance service contract shall be made on quarterly basis and the amount will be due for payment on the certification by NTPC at the end of each quarter. The quarterly amount shall be worked out by dividing the total service contract value by the number of quarters in the maintenance contract period.</p>
63.0	PROCEDURE OF PAYMENT	Payment shall be released on submission of invoice in quadruplicate along with supporting documents on certification by the Engineer-in-Charge.
64.0	JURISDICTION	Notwithstanding any other court or courts having jurisdiction to decide the question(s) forming the subject matter of the reference if the same had been the subject matter of a suit, any and all actions and proceeding arising out of or relative to the contract (including any arbitration in terms thereof) shall lie only in the Court of Competent Civil jurisdiction in this behalf at Delhi/New Delhi and only the said Court(s) shall have jurisdiction to entertain and try any such action(s) and/or proceeding(s) to the exclusion of all other Courts.
65.0	LIMITATION OF LIABILITY	<p>Except in cases of criminal negligence or willful misconduct,</p> <p>(a) the Contractor/Contractor shall not be liable to the Employer, whether in contract, tort, or otherwise, for any indirect or consequential loss or damage, loss of use, loss of production, or loss of profits or interest costs, provided that this exclusion shall not apply to any obligation of the Contractor/Contractor to pay liquidated damages to the Employer and</p> <p>(b) the aggregate liability of the Contractor/Contractor to the Employer, whether under the Contract, in tort or otherwise, shall not exceed the total Contract Price, provided that this limitation shall not apply to any obligation of the Contractor/Contractor to indemnify the Employer with respect to patent infringement.</p>
66.0	FRAUD PREVENTION POLICY	<p>The Bidder along with its associate / collaborator / sub-contractors / sub-vendors / consultants / service providers shall strictly adhere to the Fraud Prevention Policy of Employer displayed on its tender website http://www.ntpctender.com and shall immediately apprise the Employer about any fraud or suspected fraud as soon as it comes to their notice.</p> <p>The acceptance of above Fraud Prevention Policy is an attribute of the on line Bid Invitation. Acceptance of above Fraud Prevention Policy is to be given online. Only after acceptance of the above</p>

		<p>condition the bidder shall be allowed to submit the bid.</p> <p>In terms of above policy it is established that the bidder/his representatives have committed any fraud while competing for this contract then the bid security shall be forfeited.</p>
67.0	INTEGRITY PACT	<p>NTPC has in place an Integrity Pact details of which are displayed on its Tender website http://www.ntpctender.com. The Integrity Pact (IP) envisages an agreement between the prospective vendors / bidders and the buyer, committing the persons / officials of both the parties, not to exercise any corrupt influence on any aspect of the contract. The Bidder along with its associate / collaborator / sub-contractors / sub-vendors / consultants / service providers shall strictly adhere to the Integrity Pact displayed on Employers tender website http://www.ntpctender.com.</p> <p>If asked for in the SPC, a signed copy of the Integrity Pact is to be submitted with the EMD as indicated in the SPC.</p>
68.0	INDIAN AGENTS	<p>In a tender, either the Indian Agent on behalf of the Principal/OEM or Principal/OEM itself can bid but both cannot bid simultaneously for the same item/product.</p> <p>If an agent submits bid on behalf of the Principal/OEM, the same agent shall not submit bid on behalf of another Principal/OEM in the same tender for the item/product.</p>
69.0	DECLARATION ON BANNING POLICY	<p>The Owner has in place a policy for withholding and banning of business Dealings as displayed on its tender website http://www.ntpctender.com. Business dealings may be withheld or banned with the Bidder/Contractor on account of any default by the contractor under GPC clause 57 (a) to (d) or any of the grounds detailed in the said Banning Policy.</p> <p>Declaration on Policy for withholding and banning of Business dealings duly filled as per the Owner's format is enclosed in the Attachment 16 attached. The acceptance of this declaration is to be given on-line by accepting the Attribute "Declaration on Banning Policy".</p>
Important Note		<p>The Special Purchase Conditions will supersede any other related conditions any where in the tender documents and will prevail for evaluation / finalization of the tender.</p>

--- *** ---



Corporate Materials Management

Electronic tendering
e-procurement (SRM)

VOLUME – III

SECTION I

Technical specifications and Scope of Work

1.0 Intent of Specification:

Employer intends to procure APC (Advanced Process Control) software solution in each of the 4 (four) 500MW units of Simhadri Super Thermal Power Station for improving the heat rate, environmental compliance, faster load ramp up/ ramp down, achieving tighter steam temperature controls especially during disturbances and reducing minimum stable unit load, through the use of advanced control algorithms.

The main objectives of the APC solution is given below:

- 1.1. *Combustion Optimization – To increase the Unit heat rate, reduce NOx by combustion optimization of boiler while maintaining flame stability, CO limits and rated parameters of SH steam temperature, RH steam temperature and avoiding metal temperature excursions.*
- 1.2. *Soot Blowing Optimization – To increase the Unit heat rate by optimizing operation of Soot blowers (wall blower, long range and APH).*
- 1.3. *Faster load Ramp up/Ramp Down – To achieve faster ramp rates, through the development of advanced models of the Boiler response characteristics, while maintaining the rated parameters of MS pressure, SH steam temperature and RH steam temperature.*
- 1.4. *SH/RH Temperature Excursion Reduction - Temperature variations during load change and unit disturbances shall be regulated through the development of advanced models of the steam temperature processes while maintaining limits on SH & RH metal temperatures.*
- 1.5. *Reduce Min stable load – Improve control loop performance to allow stable unit operation with all control loops in auto at lower loads without oil support while maintaining flame stability.*

The above APC software is to be implemented in closed loop.

2.0 Definitions/ Abbreviations

- 2.1. Advanced Process Control (APC) shall mean the set of techniques which use a multiple input multiple output predictive model for improving the existing performance of the control loops w.r.t the desired objective (i.e. efficiency improvement or emissions reduction etc). The model can be first principles based, empirical or ANN (artificial neural network) or fuzzy logic based.
- 2.2. Combustion Optimization shall include optimizing the flue gas O2 trim, air registers, and feeder rate bias in order to improve heat rate/reduce NOx.
- 2.3. Faster load ramp up/ ramp down shall mean using APC for main steam pressure control loop. This shall include achieving tighter throttle pressure and temperature control during load changes.
- 2.4. SH/RH temperature excursion reduction shall mean using APC for SH/RH spray control loop. This shall include achieving tighter steam temperature controls during unit disturbances.

- 2.5. Standard deviation from set-point shall be calculated as the square root of variance. Variance shall be determined as summation of squared values of the variation between each data point relative to the set-point of the respective data point.
- 2.6. CVs – Controlled variables, MVs – Manipulated variables and DVs – Disturbance Variables.

3.0 Project Information

- 3.1. Simhadri Super thermal power project stage-I (2 X 500 MW) serves states of Andhra Pradesh and Telangana and Stage-II (2 X 500 MW) serves states/UTs of southern region. The project is located in Parawada mandal of Vishakapatnam District. The Project is approachable from Vishakapatnam-Yelamanchali state highway. Nearest Railway station is Anakapalle(23 Kms)/Visakhapatnam (37 Kms). The nearest airport is Vishakapatnam, at a distance of about 30 kms from the project.
- 3.2. Details of Main Plant
Boiler-M/sBHEL(CE Design),Controlled Circulation With Rifled–Tubing, Dry-Bottom, Radiant Reheat, Single Drum, Top Supported,Dry botton, Balanced Draft Furnace of volume 16424 M3,Depth 15.797 M , Width 19.177 M.
Turbine-M/s BHEL(KWU Design),Three Cylinder Reheat Condensing Turbine,HPT 17 Reaction stages,IPT 12 X 2 Reaction stages,LPT 6 X 2 Reaction stages.HPT-2Nos Main Stop and Control Valves,IPT -2 Nos RH Stop and Control Valve,CRH line – 1 Swing Check Valve,LPBP–2 Nos Bypass Stop and Control Valves.
Condensor is cooled with sea water in closed cloop using natural draft cooling towers.
- 3.3. Historial Operation Data
The available historical data of the APC related tags of last one year shall be provided to the Bidder on a CD subject to the Bidder signing a non-disclosure agreement/undertaking for maintaining strict confidentiality of the data provided.
Any other data required by the Contractor/Bidder shall be provided on request basis, subject to Employer’s approval.
- 3.4. Details of existing DCS and interfacing with APC are provided in Annexure-I.

4.0 Scope of Work:

- 4.1. Contractor’s scope under this package shall include but not be limited to design, testing, supply, installation, commissioning of APC (Advanced Process Control) software for each of the Four(4) units of Simhadri Super Power Station, along with required hardware, interface software and training as per specifications laid down in this tender document.
- 4.2. The Bidder shall provide all the related services for design, development/configuration, implementation, installation of software and control scheme, performance testing, training, warranty, AMC etc.
- 4.3. The requirements for APC are indicated on functional basis in the specification. Refer Section 6 for details of APC functional requirements. Contractor shall be responsible for engineering, selection and connection of all components and subsystems to form a complete system whose performance is in accordance with functional, hardware and other

requirements of these specifications. It is not the intent or purpose of this specification to specify all individual system components since the Contractor has full responsibility for engineering and furnishing of a complete system to meet the objectives laid down in this specification.

- 4.4. As a min., one (1) no. Operator station of APC (to be placed in unit control room) and one (1) no. engineering station (to be placed in programmer room) are to be provided for each Unit.
- 4.5. Each unit shall have individual APC hardware i.e. intermixing of same hardware for more than one unit shall not be allowed. However, to implement remote connectivity, equipment can be common for multiple units. The hardware shall be sufficient to meet all the functional requirements of this specification.
- 4.6. All the cables (along with all connecting equipment) from Contractor's APC system to the Employer's DCS shall be in the scope of the Contractor. This shall also include power cables from Employer's ACDB/DCDB to Contractor's equipment.
- 4.7. In addition to the hardware for APC (servers, workstations, controllers etc), furniture including tables and chairs shall also be provided. Controllers/ Electronic modules, if provided, shall be housed inside modular racks/panels. The exact arrangement shall be subjected to Employer's approval during kick off meeting.
- 4.8. All software required to achieve the above functional requirements shall be included in the scope of this package and shall be provided to Employer with lifetime licenses in CD/DVD media or any other downloadable format. These shall be site license including the operating system, modelling and optimization software and any other software required for proper functionality of the complete system.
- 4.9. The software licenses shall not be hardware/machine-specific. That is, if any hardware/machine is upgraded or changed, the same license shall hold good and it shall not be necessary for Employer to seek a new license/renew license due to upgradation/change of hardware/machine for APC at site.
- 4.10. The offered APC software should utilize latest hardware and software versions. The operating system should also be latest available like Windows 10.
- 4.11. Software updates including new releases, versions, fixes, patches etc. shall be provided as and when released by the contractor without any additional cost to NTPC during the warranty period and also during the AMC period. These shall include operating system patches, antivirus software/signatures, firewall software/signatures.
- 4.12. In case, the version available at the time of supply and commissioning is not compatible to latest OS version, then the Contractor should upgrade all the software to latest OS version, when the same is available, without any additional cost before the end of warranty period.
- 4.13. The interpretation of the Employer in respect of the scope, details and services to be performed by the Contractor shall be binding, unless specifically clarified otherwise by the Employer in writing during the bidding stage.

5.0 Terminal Points and Exclusions:

5.1. Terminal Points:

1. Upto Employer's interface card(s) in DCS

2. Employer's existing one no feeder of 230 V AC UPS ACDB/PDB for extending power to Bidder's APC equipment.
3. Employer's existing one no feeder of 24 V DC DCDB for extending power to Bidder's APC equipment.

5.2. Exclusions:

1. 230 V AC Power supply, 24 V DC Power supply.
2. All modifications in the existing control scheme as per clause 6.19.1.

6.0 Functional Requirements:

Advanced Process Control (APC) shall consist of the following:

6.1. **Combustion Optimization**

- 6.1.1. The combustion optimization APC software needs to be tuned to optimize for both scenarios (i) Heat rate, (ii) Nox. The facility to select the desired objective among the two should be selectable by Operator from DCS workstation/APC workstation. The performance testing shall be conducted by selecting Heat rate as optimization objective.

6.2. **Soot Blowing Optimization**

- 6.2.1. Soot blowing optimization, when put in closed loop, should raise an alarm to operator in DCS at least 30 min prior to carrying out Soot blowing operation, to provide sufficient time to ensure local monitoring, as required.

6.3. **Faster load Ramp up/Ramp Down**

- 6.3.1. Faster load ramp up/ ramp down shall mean using APC for main steam pressure control loop. This shall include achieving tighter throttle pressure and temperature control during load changes.

6.4. **SH/RH Temperature Excursion reduction**

- 6.4.1. SH/RH temperature excursion reduction shall mean using APC for SH/RH spray control loop. This shall include achieving tighter steam temperature controls during unit disturbances.

6.5. **Reduce Min stable load**

- 6.5.1. Improve control loop performance to allow stable unit operation with all control loops in auto at lower loads without oil support while maintaining flame stability.

6.6. **Interfacing with Existing DCS:**

- 6.6.1. The APC software shall interface in real time with the existing DCS of each of the Simhadri units through MODBUS TCP/IP for collecting data and sending commands back to DCS for changing the bias/setpoints/controller outputs of the closed loop controls in the existing DCS.
- 6.6.2. Typical outputs from the APC shall include Aux. air damper bias, Overfire air damper bias, burner tilt bias, Feeder bias, FG O2 SP bias, Fuel Master SP bias, CMC Load SP to TG bias etc. For SH/RH steam temperature, the outputs shall be either spray demand bias or direct output switchover. Bidder to include detailed scheme of the APC indicating the input tags from DCS as well the output tags from the APC system. The exact APC scheme along with the signal exchange list between APC and DCS shall be finalized with the Employer during kick off/ engineering stage.

- 6.6.3. Typical interfacing scheme with existing DCS is attached as drawing 3500-404-POI-A-001, 3500-404-POI-A-002.
- 6.7. All set-point/bias adjustment would be in the range of acceptable limits finalized during design/engineering, not exceeding 10% of the operator provided set-points.
- 6.8. The Contractor shall take into account all regimes of the operation of the units during the design of his APC system. Further, all constraints of the units shall be taken into consideration during the APC design. The improvements intended are w.r.t the 'AS IS' state of the plant.
- 6.9. The APC shall not violate any of the physical, operational, metallurgical constraints of any plant equipment. It shall ensure safe and stable control technologies so that it does not cause physical damage to the equipments.
- 6.10. The APC software shall not result in deterioration of existing control loop performance or unit parameters in any way.
- 6.11. The APC solutions offered should not require any mechanical modification in the plant.
- 6.12. Further, Bidder should familiarize with the measurements existing at site. The model should be able to deliver the benefits based on the existing measurements. Bidder to provide CO Analyzer at Economizer outlet (L/R) - 2 (Two) No. per Unit. Installation of additional sensors and associated works would be permitted, subject to Employer's approval during engineering. Supply and installation shall be in Contractor's scope without any additional cost implication to Employer.
- 6.13. The APC software should have adaptive control features i.e. it should take into account actual unit conditions and constraints for giving the bias/set-points/control outputs. The APC model should be self-tuning to automatically adjust to actual unit conditions and constraints. Bidder to submit write-up in the bid explaining how the same is achieved.
- 6.14. Employer shall try their best to provide any other data relevant to the development of APC. However, non-availability of design data shall not be a bottleneck to implementation of APC.
- 6.15. **GUI for the APC:** The software should have graphic displays to control the execution of the optimization solution and perform following functions:
 - 6.15.1. Viewing the constraints
 - 6.15.2. Enabling/ Disabling the constraints with proper security privileges
 - 6.15.3. Enable/Disabling the APC solution with bumpless transfer to existing DDCMIS.
 - 6.15.4. Facility of creating custom displays shall be provided.
 - 6.15.5. The APC should be capable of handling on line changes in control objectives (constraint limit changes/ priority changes/ setpoint or range target changes) without switching off the APC.
 - 6.15.6. Trends for process values, APC parameters etc., alarm page for showing alarms generated by APC software.
- 6.16. Historization of APC inputs, calculated values and outputs i.e all CVs, MVs and DVs.
- 6.17. Snapshot of best achievable performance (i.e Heat rate) in a given set of conditions to be available in the APC software.

- 6.18. KPIs of APC being generated in APC software shall also to be transferred to existing DCS over the interface link. These shall be configured in existing Station LAN server for sending to PI and dashboard shall be created in PI for monitoring performance of APC software.
- 6.19. In existing DCS Operation workstations, suitable graphics shall be built by Employer, as per the suggestions of the contractor, in order for operator to monitor and access the optimizer informations easily. Operator should be able to easily switch APC ON/OFF.
- 6.20. The Contractor shall furnish the red lined modifications in the existing control schemes of the DCS. This shall cover the following two broad cases:
 - 6.20.1. Switchover between Conventional control and APC for the bias/set-point/controller output, as per the scheme approved by the Employer.
 - 6.20.2. Improvements in the existing Control schemes including any adaptive control logic for reducing min. stable load as well as enhancing the objectives of APC. Implementation of these shall be done after completion of SAT of all other APC software.
- 6.21. **Fail safe design:** APC implementation should ensure fail safe design, so that in case the operating conditions are away from zone of optimization or in case of malfunction of APC or failure of communication link , the control functionality of existing DDCMIS, as without APC is maintained. In order to ensure this, each of the above APC solution should have individual 'start/stop' functionality. In the above scenario, the respective APC solution will automatically 'stop' with bumpless transfer to existing DDCMIS and give alarm to operator. Suitable setpoint and bias tracking functions also to be implemented.
- 6.22. A permissive shall be built for APC ON in the existing DCS to check the Unit stability and APC shall be put on only when this permissive is available.
- 6.23. **Watchdog:** Suitable watchdog logic to be incorporated for healthiness of the optimizer. It shall be ensured that in case of failure of APC or its communication interface, there shall be no bump in the existing controls. In case of APC ON, the DCS shall track the APC signals and in case of APC OFF, the APC signal shall track the DCS signals. Annunciation indicating any failure of APC shall be provided for display in the LVS (Large Video screen).
- 6.24. Direct interfacing with the existing DCS, i.e APC node directly sitting on existing DCS network, can be proposed by the Bidder, if the Bidder is OEM of existing DCS, subject to Employer's approval. In such a case, the Bidder has to produce documentary evidence to establish that similar architecture is in service in an existing installation.
- 6.25. Bidder shall be responsible designing cyber security architecture for connecting to existing DCS. This will include providing modbus aware multi-port hardware firewalls for each unit, for communication with each DCS. Further, latest antivirus software with IPS, shall be provided for all workstations.
- 6.26. **User level security:**
 - 6.26.1. The software shall support advanced security methods to provide protection against unauthorized access, disclosure, modification, and use. The Contractor shall describe the security provided by the software for user login and roles.
 - 6.26.2. The application shall provide capabilities for user creation, deletion, lockout, login and password reset facilities.
 - 6.26.3. The software shall allow tracking of all user access to the applications.
- 6.27. **Improvement in Existing Control Schemes**

- 6.27.1. The improvements in the existing control schemes shall be submitted for Employer’s review after the SAT and implemented before the start of the six month performance test. Further, after implementation of these improvements, the Contractor shall also tune the existing control loops for better control loop performance during the stipulated load ranges.
- 6.28. **Location:** The APC equipment i.e. servers, workstations, controller along with the furniture shall be located in the CCR/CER of respective Units.
- 6.29. **Remote connectivity:** Bidder shall provide the necessary hardware & software required for connecting the APC system to Bidder's remote service centre, through which the diagnostics & fault analysis of the APC system can be carried out. In no case tuning of the model is allowed from remote, when APC is in ON mode. The method of connection shall be as per Bidder's standard practice using a firewall, subject to employer’s approval–during detailed engineering. Virtual Private networks (VPN) technology shall be used for data integrity and confidentiality. However, it is preferred to have the connection through a single point in the APC system. Further, this access shall be strictly under request control & record of such access shall be made available to the Employer’s designated personnel. The fixed charges & running cost till warranty period shall be included in the Quoted Price. The running cost thereafter shall be included in the AMC price.
- 6.30. The software shall be suitable for life time of the plant.
- 6.31. All the hardware like server/workstations/controller, protocol converters as required for meeting the functional requirement of this specifications, shall be provided by the Contractor.
- 6.32. Bidder shall include a detailed BOM (hardware and software) of the proposed APC solution in the bid.
- 6.33. Contractor shall depute experienced personnel for the commissioning of the APC. The details of the proposed engineers along with their experience data shall be included in the bid. Bidder shall propose the same personnel who had executed the APC in the reference project, if the personnel is on the payrolls of the Bidder or the Bidder’s associate. Any request for substitution by new engineer during the execution of the project shall be subject to Employer’s approval and upon submission of proper justification document by the Contractor.

7.0 Work Schedule:

Sl No	Activity	Activity Target (in no. of Months from post award)
1.	Kick off meeting at site identifying the phases of project along with the units, identification of tag list with KKS/address in existing as built logics required in APC, familiarization with existing controls & operation philosophy of stage-I & stage-II. Modbus prototype communication test in C&I Lab with procontrol/maxDNA/Ovation with test hardware.	0.5

2.	Supply: Supply of complete hardware & software for first Unit	1
3.	Installation: Installation of software and interface testing for first Unit	1.5
4.	Commissioning: Commissioning of the System in first Unit	2.5
5.	Training of Employers employees phase-I	3
6.	SAT (Site acceptance testing) for Performance Testing: Performance Testing of System in first Unit	5
7.	For Second, third and fourth Unit: Phase wise installation, commissioning and SAT for performance testing in other three units	12
8.	Continuous running performance testing of system	15
9.	Training of Employers employees Phase-II	After completion of installation of the system in each unit of each stage.
10.	Completion of facilities	16
11.	Final Documentation & handover of the system to the employer	18

8.0 SAT (Site Acceptance Test) for Performance Testing:

Site acceptance test shall be conducted for evaluating the performance of the APC software.

- 8.1. Site Acceptance Testing Setup: The SAT shall be done after completion of commissioning of the software (including interface testing, checking of fail-safe implementation etc).
- 8.2. In order to measure the performance of APC software, SAT would be conducted by comparing performance between APC Off and APC On scenarios.
- 8.3. Period of APC OFF and APC ON would be as per the details given in the table below, maintaining similar time of the day, to the best possible extent.
- 8.4. SAT of each of the APC solutions shall be done in the order indicated in the table.
- 8.5. As indicated above, implementation of improvements in the existing control schemes for min. stable load reduction as well as for enhancing the objectives of APC, shall be done after completion of SAT of all other APC software. Accordingly, SAT of the same shall be done subsequently.

- 8.6. In case vendor proposes to utilize their software for baselining and APC ON/OFF test calculations, the same shall be subject to employer's approval.
- 8.7. In case, it is required to change historian settings in existing DCS to archive required inputs/outputs/results of APC, the same shall be mutually agreed and accordingly shall be implemented by Employer.
- 8.8. In case of soot blowing, like all other tests, system shall be in closed loop during APC ON. However, if the plant decides to keep the sootblowing on advisory instead of closed loop, the same shall be tested in this mode; however all advisories shall be followed during the test period.
- 8.9. Contractor to also demonstrate the Combustion optimization APC software capability of reducing NOx. However, it will be reverted back to heat rate objective after demonstration.
- 8.10. Suitable precautions to be taken to ensure that there is no equipment/unit outage due to the conductance of the SAT.
- 8.11. In case during any test, any unforeseen condition arises in the Unit leading to change in test scenario, then the test can be repeated, subject to Employer's approval.
- 8.12. In case, the contractor is not able to achieve the performance figures during any test, without any reason attributed to the Employer, contractor can request for re-conductance of the test. However, this reconductance shall be subject to Employer's approval.
- 8.13. CPG (Contract Performance Guarantee) shall be released if the Contractor achieves the minimum improvement figure as indicated in Payment terms at clause 10.0 for SH/RH temperature excursion reduction, Faster load ramp up/ramp down, Combustion optimization and Soot blowing optimization.
- 8.14. Following prerequisites to be considered during the testing period to ensure similar operating conditions between APC ON duration and APC OFF duration.
 - 8.14.1. Load conditions of the unit would be similar and RGMO (Restricted governing mode of operation) would be kept disabled.
 - 8.14.2. Coal quality to be kept consistent. Coal sample to be taken during each of the test period. Coal parameters (measured on coal flow) to be within 5% variation during the period.
 - 8.14.3. Mill combination and other auxiliaries to be maintained same during the test period.
 - 8.14.4. All the loops shall be in Auto and no manual adjustment during the test period.
 - 8.14.5. All set-point/bias adjustment would be in the range of acceptable limits finalized during design/engineering, not exceeding 10% of the operator provided set-points.
 - 8.14.6. Ambient conditions must be similar. i.e. ambient temperature within ± 2 Deg C and relative humidity within $\pm 5\%$.
 - 8.14.7. For Soot Blowing optimization test, specific coal [i.e. coal consumption (t/hr)/ load (mw)] variation of $\pm 5\%$ shall be considered as similar operating condition.
 - 8.14.8. If variation in above parameters is higher than the limits stated above, then the test can be reconducted.
- 8.15. In regard to any dispute arising during the testing, the decision of Employer's test team shall be final and binding on the Contractor.

8.16. The table below lists the different test scenarios for each objective of APC solution. In each of this test scenario, in one iteration APC software will be 'kept off' and in other iteration, in the same scenario, APC software will be 'made on', to capture performance parameters, as listed in table below. During APC 'on' test, there should not be deterioration of existing controls.

APC Solution	Test Scenario			To be Measured	No. of test for each range or scenario / Duration of each test
	Load (Steady State / Dynamic)	Load Range Scenarios (TMCR)	Other scenarios		
SH/RH Temperature Excursion Reduction	Steady State	1) Range 1 - 100% (+/-5%) loading factor 2) Range 2 - 80% (+/-5%) loading factor 3) Range 3 - 55%-60% loading factor	During Soot Blowing (as per current practice), During Mill Changeover and other conditions as decided during detail engineering.	Standard deviation of SH Steam Temp (LHS & RHS) and standard deviation of RH Steam Temp (LHS & RHS), from respective set-point, for every 1 sec sample, keeping other parameters, as per Table A below, within limits.	3 tests / 4 hr.
Faster Ramp up/Ramp Down	Dynamic	1) Range 1 - 100% to 70% loading factor and vice versa 2) Range 2 - 70% to 55% loading factor and vice versa	SH/RH temp Excursion Reduction APC software to be kept ON during 'APC ON' of this test.	Standard deviation of Throttle Pressure, SH Steam Temp (LHS & RHS) and RH Steam Temp (LHS & RHS), from respective set-point, for every 1 seconds sample, keeping other parameters, as per Table B	3 tests / As required, max. 2 hours.

				below, within limits.	
Combustion Optimization	Steady State	1) Range 1 - 100% (+/-5%) loading factor 2) Range 2 - 80% (+/-5%) loading factor 3) Range 3 - 55%-60% loading factor	- SH/RH temp. Excursion reduction and Faster Ramp up/Ramp down APC software to be kept ON during 'APC ON' of this test. - In Range 1, test would be conducted at 3 (three) different coal qualities.	Heat Rate using delta heat rate method as per parameter and weights given by below table. Data Sampling at every 1 second.	3 tests / 4 hr
Sootblowing Optimization	Steady State	Any load range. (As per Scheduled generation)	SH/RH temp. Excursion reduction and Faster Ramp up/Ramp down APC software to be kept ON during 'APC ON' of this test.	Heat Rate using delta heat rate method as per parameter and weights given by below table. Data Sampling at every 1 second.	2 tests / 8 days
Reduce Min stable load	Steady state	50% loading factor	'APC OFF' test is not applicable. All APC software to be kept ON.	Min. load at which stable control is available ie. control loops, as listed below, are functioning in auto without oil support while maintaining flame stability, keeping other parameters, as per Table C below, within limits	Stable load for 1 hrs

Table A - Parameter deviation limits to be maintained during SH/RH temperature excursion reduction test
Metal Temp (Deg C)
SH & RH, Tube metal temp. and Header metal temp, not greater than specified operating limits for more than 10 secs.

Table B - Parameter deviation limits to be maintained during Faster Ramp up/Ramp down test				
Load Change (% of MCR per min.)	FG O2 Deviation (% O2)	Furnace Pressure Deviation (mmwcl)	Drum Level deviation (mmwcl)	Metal Temp (Deg C)
3%	+0.6/-0.4	±12.0	±25.0	SH & RH, Tube metal temp. and Header metal temp, not greater than specified operating limits for more than 10 secs.
5%	+0.8/-0.4	±12.0	±30.0	
10%	+1.0/-0.5	±15.0	±50.0	

Table C - Parameter deviation limits to be maintained during Min Stable load test				
Throttle Pressure Deviation (Kg/Cm2)	SH & RH Temperature (Deg C)	Furnace Pressure Deviation (mmwcl)	Drum Level deviation (mmwcl)	Flue Gas (% O2)
±2.0	±5.0	±8.0	±15.0	±0.4

For each APC software solution except reduce Min stable load, Improvement calculation shall be as follows:

1. **(A) For SH/RH Temperature Excursion Reduction and Faster Ramp up/Ramp Down:**
Improvement of individual test scenario: Improvement of each test scenario will be calculated by taking difference between 'APC On' and 'APC off' value of measured parameter, for that scenario. For, more than one parameter, individual value of measured parameter shall be added to arrive at total value of measured parameters, for that scenario. Improvement shall mean reduction in standard deviation.

E.g. Calculation for SH/RH temperature excursion reduction, in any given test scenario.

During 'APC OFF'.

Value of Standard deviation in 'APC OFF' = (Std deviation in SH Steam Temp LHS + Std deviation in SH Steam Temp RHS + Std deviation in RH Steam Temp LHS + Std deviation in RH Steam Temp RHS) during that test scenario in 'APC OFF'

During 'APC ON'

Value of Standard deviation in 'APC ON' = (Std deviation in SH Steam Temp LHS + Std deviation in SH Steam Temp RHS + Std deviation in RH Steam Temp LHS + Std deviation in RH Steam Temp RHS) during that test scenario in 'APC ON'

Improvement of that test scenario = Value of Standard Deviation in 'APC OFF' - Value of Standard Deviation in 'APC ON'

(B) For Combustion Optimization and Soot Blowing Optimization:

Improvement in Heat rate using delta heat rate method shall be calculated as below for 'APC ON' and 'APC OFF' of each of the test scenarios. Improvement shall mean reduction in heat rate.

The delta heat rate for evaluating Combustion optimization will be as per below formula:

%Delta HR for Combustion Optimization=

$$\begin{aligned}
 &A1 * (MST_{APC\ ON} - MST_{APC\ OFF}) + \\
 &A2 * (RHT_{APC\ ON} - RHT_{APC\ OFF}) + \\
 &A3 * (SH\ spray\%_{APC\ ON} - SH\ spray\%_{APC\ OFF}) + \\
 &A4 * (RH\ spray\%_{APC\ ON} - RH\ spray\%_{APC\ OFF}) + \\
 &A5 * (O2\%_{APC\ ON} - O2\%_{APC\ OFF}) + \\
 &A6 * (FGTAH\ outlet_{APC\ ON} - FGTAH\ outlet_{APC\ OFF}) + \\
 &A7 * (Unburnt\ C\% \text{ in Fly Ash}_{APC\ ON} - Unburnt\ C\% \text{ in Fly Ash}_{APC\ OFF}) + \\
 &A8 * (Unburnt\ C\% \text{ in Bottom Ash}_{APC\ ON} - Unburnt\ C\% \text{ in Bottom Ash}_{APC\ OFF})
 \end{aligned}$$

The delta heat rate for evaluating Soot blowing optimization will be as per below formula:

%Delta HR for Soot blowing =

$$\begin{aligned}
 &A1* (MST_{APC\ ON} - MST_{APC\ OFF}) + \\
 &A2* (RHT_{APC\ ON} - RHT_{APC\ OFF}) + \\
 &A3* (SH\ spray\%_{APC\ ON} - SH\ spray\%_{APC\ OFF}) + \\
 &A4* (RH\ spray\%_{APC\ ON} - RH\ spray\%_{APC\ OFF}) + \\
 &A5* (O2\%_{APC\ ON} - O2\%_{APC\ OFF}) + \\
 &A6* (FGTAH\ outlet_{APC\ ON} - FGTAH\ outlet_{APC\ OFF}) + \\
 &A7* (Unburnt\ C\% \text{ in Fly Ash}_{APC\ ON} - Unburnt\ C\% \text{ in Fly Ash}_{APC\ OFF}) + \\
 &A8* (Unburnt\ C\% \text{ in Bottom Ash}_{APC\ ON} - Unburnt\ C\% \text{ in Bottom Ash}_{APC\ OFF}) + \\
 &A9* (SBflow_{APC\ ON} - SBflow_{APC\ OFF})
 \end{aligned}$$

Note: Parameter value during 'APC ON', 'APC OFF' shall be average of value for test duration at 1 second sample rate.

e.g. $MST_{APC\ ON}$ = Average (MST during 'APC ON' for test duration at 1 sec sampling rate)

The weights of parameters A1 to A9 will be as per below table:

Coefficient	Parameter	Weight	Remarks
A1.	Main Steam Temperature	-0.029%	%HR/1degC
A2.	Reheat Temperature	-0.026%	%HR/1decC
A3.	Superheat Spray% ¹	0.025%	%HR/1% spray
A4.	Reheat Spray% ¹	0.22%	%HR/1% spray
A5.	Flue Gas O2% at Eco Outlet	0.25%	%HR/1% O2
A6.	Flue Gas Temperature at AH outlet	0.05%	%HR/1degC
A7.	Unburnt C% in Fly Ash ²	0.4%	%HR/1%
A8.	Unburnt C% in Bottom Ash ²	0.1%	%HR/1%
A9.	Soot Blowing Steam Flow	0.067%	%HR/1T/hr

¹ %spray = spray flow as % of rated MS flow.

² Bottom ash and fly ash samples will be analyzed for unburnt carbon % by weight as per ASTM D 7348-13.

2. **Net improvement:** Net improvement of an APC software solution, will be calculated by taking average of all the improvement value (positive/negative) achieved for individual test scenario, calculated as per above clause.

All improvement figures to be rounded to two decimal places. i.e 1.555 = 1.55, 1.556=1.56.

9.0 Continuous Performance Test:

After the conductance of SAT with APC ON/OFF methodology, a continuous run of the system with APC permanently ON will be conducted for a period of six months for each unit to ascertain that heat rate benefits due to APC implementation are being consistently maintained.

In order to calculate the same, the APC ON/OFF test shall be conducted, with all APC software kept ON, every 15 days for a period of six months. This test shall be done at 100% (+/- 5%) loading factor for a period of 4 hours. Delta Heat rate methodology, as given in this document shall be utilized for calculating the heat rate improvements. Average results of all these tests shall be taken to arrive at average heat rate improvement of continuous performance test. In case, the heat rate improvement of continuous performance test is lesser than that achieved during SAT, then the contractor shall take necessary corrective measure to achieve same level of performance as achieved in SAT.

The average heat rate benefit achieved with APC implementation during continuous performance test shall be documented. If the same results in heat rate improvement of more than 0.5% (as per above procedure), a letter of appreciation from the Station Management with the achieved heat rate benefit shall be given to the Contractor.

It may be noted that NTPC's decision w.r.t achieved heat rate benefit shall be final and binding on the Contractor. No representation whatsoever from the Contractor in this regard shall be entertained. Further, no monetary reward/incentive or compensation shall be given to the Contractor, for achieving the heat rate benefit over and above 0.5% or achieving better improvement in parameter standard deviation over the value stipulated in this contract.

10.0 Break-up of SAT:

S No	Item	Payment Percentage	Remarks
1	Initial Advance	5%	
2	Kick off Meeting at Site and finalization of required documents and procedures (Approval of	5%	

	Employer)		
3	Material Receipt to Site	5%	To be split unit wise
4	SAT	80%	To be split unit wise
A	SH/RH Temperature Excursion Reduction	25%	To be split unit wise & Distribution as per SNo A of below table
B	Faster load Ramp up/Ramp Down	10%	To be split unit wise & Distribution as per SNo B of below table
C1	Combustion Optimization	40%	To be split unit wise & Distribution as per SNo C of below table
C2	Soot Blowing Optimization		To be split unit wise & Distribution as per SNo C of below table
D	Reduce Min. stable load	5%	To be split unit wise & Distribution as per SNo D of below table
5	COF	5%	To be split unit wise

SNo	Performance Milestone	Milestone
A	Net Improvement in Standard Deviation of SH & RH steam temperature excursion	<p>1. For, Net Improvement in Standard Deviation of SH & RH steam temperature excursion between 10% to 50%, payment shall be in the range of 5% to 25% of PO price (incl tax).</p> <p>Example: Net Improvement = 30%, payment (incl. Tax) is</p>

	(as per clause 8.16 above)	<p>calculated as follows: $5\% + [\{ (25\%-5\%) / (50\%-10\%) \} * (30\% - 10\%)]$</p> <p>2. For Net Improvement in Standard Deviation of SH & RH steam temperature excursion of 10% ; Payment of 5% of PO price (incl. Tax).</p> <p>3. For Net Improvement in Standard Deviation of SH & RH steam temperature excursion of <10%; no payment.</p>
B	Net Improvement in Standard Deviation of Throttle Pressure, SH and RH steam temperature excursion (as per clause 8.16 above)	<p>1. For, Net Improvement in Standard Deviation of Throttle Pressure, SH and RH steam temperature excursion between 10% to 50%, payment shall be in the range of 2% to 10% of PO price (incl tax).</p> <p>Example: Net Improvement = 30%, payment (incl. Tax) is calculated as follow: $2\% + [\{ (10\%-2\%) / (50\%-10\%) \} * (30\% - 10\%)]$</p> <p>2. For Net Improvement in Standard Deviation of Throttle Pressure, SH and RH steam temperature excursion of 10% ; Payment of 2% of PO price (incl. Tax).</p> <p>3. For Net Improvement in Standard Deviation of Throttle Pressure, SH and RH steam temperature excursion of <10%; no payment.</p>
C	Net Improvement in Unit Heat Rate by Combustion optimization and Soot blowing optimization (Summation of results of SAT of each of this APC solution) (as per clause 8.16 above)	<p>1. For Net improvement in Unit Heat rate between 0.1% to 0.5%, payment shall be in the range of 8% to 40% of PO price (incl tax).</p> <p>Example: Heat rate improvement = 0.15%, payment (incl. Tax) is calculated as follow: $8\% + [\{ (40\%-8\%) / (0.5\% -0.1\%) \} * (0.15\% - 0.1\%)]$</p> <p>2. For Net improvement in Unit Heat rate of 0.1% ; Payment of 8% of PO price (incl. Tax).</p> <p>3. For Net improvement in Unit Heat rate of < 0.1% ; no payment.</p>
D	Improvement in Stable Min. Load (as per clause 8.16 above)	<p>1. For Achieving Stable Min load of 50% loading factor, payment of 5% of PO price (incl. Tax)</p>

11.0 Warranty and AMC:

Comprehensive warranty of complete APC system (hardware & software) for a period of one(1) year from the completion of the SAT shall be provided. The warranty period for each unit shall start after completion of SAT of that unit. This shall include services every quarter for tuning of the APC software including the models. The routine and preventive maintenance during the period of warranty shall also be carried out by the Contractor. This warranty shall include repair, replacement or correction of identified software or hardware discrepancies at no cost to the employer. Bidder shall depute adequate experienced personnel as and when required during the warranty period to ensure 99% system availability.

Comprehensive on-site hardware/software Annual Maintenance Contract (AMC) shall be provided for a period of three(3) years after the completion of comprehensive warranty period. AMC shall be applicable after expiry of the warranty period of the respective unit. The comprehensive AMC shall cover total maintenance of all hardware & software coming under the scope of Bidder and shall include free repair/replacement of all peripherals/cables/components, etc. correction of software problems and supply of expendable items. This shall also include services every quarter for tuning of the APC software including the models. The Bidder shall ensure 99% availability of the system with AMC. For the purpose, contractor may maintain adequate no. of staff at site as per his own assessment if considered necessary to ensure availability. However, the Contractor should depute APC expert every six months for a period of min. three days during AMC in order to check the proper and effective functioning of the system.

As indicated at Section 4 Scope of Work, all software updates, include operating system patches, antivirus software/signatures, firewall software/signatures, shall be provided during warranty period as well as AMC period without any additional cost implication to NTPC.

Bidder shall include details of the agency providing this support in the bid. This support can be from remote location as per the standard practice of the Bidder. Bidder shall include details of the setup for remote support in the bid. All hardware/software for this purpose shall be included in Bidder's scope.

12.0 Training:

12.1 Developer/ Administrator level training: The Contractor shall provide detailed training to Employer's eight(8) engineers at the works of the APC technology provider, for a period of one week, which will ensure complete self sufficiency in implementing, operating, troubleshooting and maintaining the complete APC solution. This training shall be conducted by personnel well qualified and having in-depth knowledge of the offered technology and having experience of implementation of the offered technology. At the end of this training,

the participants shall be able to tune the settings of the APC software in order to account for plant/equipment characteristics change or modification in the objectives of the APC solution. The details of the developer/ administrator level training such as course contents, location, time schedule etc shall be included in the bid. The above training shall be split into batches (min. two batches) to facilitate smooth technology absorption.

12.2 User level training: The Contractor shall provide user level training to fifty(50) no.s of Employer's operation personnel at site for 2-3 working days. The training shall be held in two batches, one batch for each stage. This training need to be conducted before the commissioning activity of the APC of the respective stage.

12.3 APC Familiarization: The Contractor shall provide a one day familiarization on the offered APC solution at site during the kickoff meeting. There shall be no limitation on the number of participants for this familiarization programme. The intended audience will include station management and RED.

Training Material shall be provided to each of the participants of the above courses.

13.0 **Documentation:**

Bidder to provide all standard product manual, O&M manual etc. for all the components of the APC solutions.

Bidder to submit Function Design specification, of system, hardware, system software and any third party systems including but not limited to interfacing with DCS, remote connectivity ,datasheets of all hardware based on the discussion during kick off meeting for review of Employer. Bidder to revise the document incorporating changes mentioned by Employer and submit the FDS before supply of the equipment to site. Bidder to submit detailed testing procedure for each module of APC as per site configuration for approval of EIC. Based on their comments bidder to submit revised testing procedure. It is the responsibility of bidder to get the testing procedure approved well before start of performance testing. Final documentation must include the procedures like system restoration, license restoration, taking backup, trouble shooting of the system.

Annexure-I

Details of Existing DCS & Interfacing with APC:

For Stage-I units, PROCONTROL P13/42 system has been supplied by BHEL,EDN for SG, TG as well as BOP C&I. The procontrol DDCMIS through interface module 70BK08b for each of 4 IPBs shall be interfaced for bi-directional communication with APC.

For Stage-II units, Ovation 3.2 has been supplied by Emerson process management for BOP C&I. maxDNA 4.5 has been supplied by BHEL-EDN for SG integral &TG integral systems. modbus of Ovation through IP switch and modbus over maxNET through EB block of maxDNA shall be interfaced for bi directional modbus communication with APC.

Existing Control Loops:

The following control loops are part of existing control system:

O2 Setpoint, WB/Furnace DP, Furnace Pressure, FD Fan Balance, ID Fan Balance, PA Fan Balance, Aux Air Flow/Dampers, Fuel Air Dampers, Burner Tilt Position, Mill Speed (Feeder Speed), Primary Air Flow, Secondary Air Flow, Mill (AirFlow), Fuel Air Temperature, Drum Level Control, FW Flow, SCAPH Temp Control, SH steam temp. Control, RH steam temp. Control, D/A level control, D/A Pr control, CEP hdr pr control, Fuel master, Boiler master ,CMC.

This document is the property of NATIONAL THERMAL POWER CORPORATION LTD. No part of this document will be reproduced by any means without the written permission.

EXISTING CONTROL SYSTEM U#1

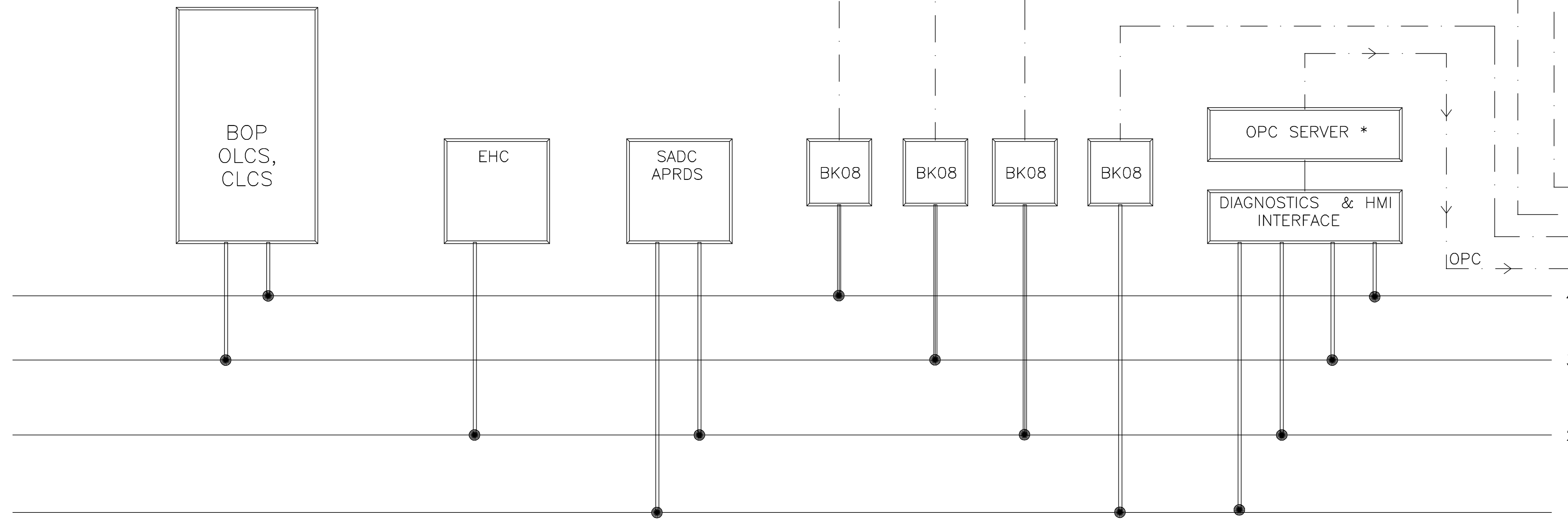

MULTIPORT FIREWALL

APC MODULE U#1

EXISTING CONTROL SYSTEM U#2

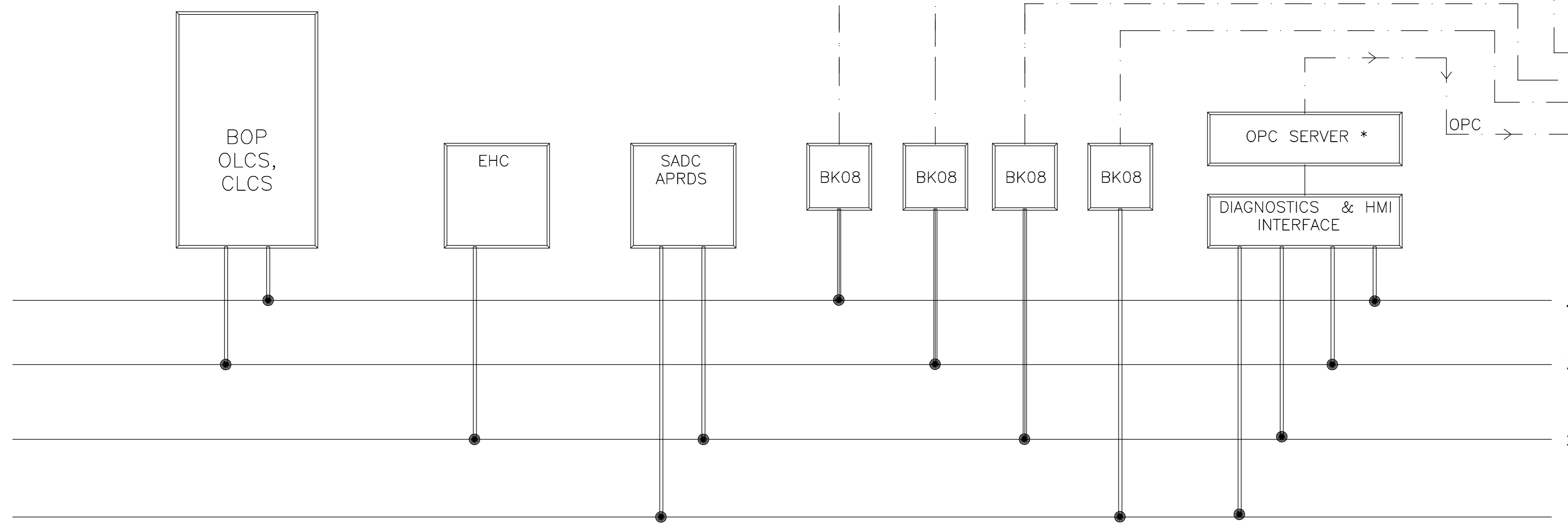

MULTIPORT FIREWALL

APC MODULE U#2

NOTE:-
 1. Bidder has to provide individual hardware for APC (includes server, modbus gateway ,firewall (to allow modbus & OPC(if applicable) only)) for each unit separately.
 2. Bidder has to provide cables & connectors up to employers existing panels where interface cards/switches were mounted.
 3.(*) OPC server interface is optional only

FOR TENDER PURPOSE ONLY

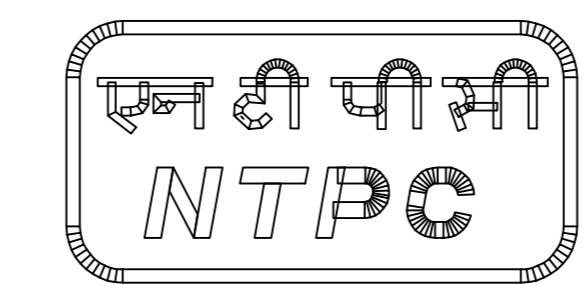

NTPC Limited
 (A GOVERNMENT OF INDIA ENTERPRISE)
ENGINEERING DIVISION

PROJECT:- **SIMHADRI SUPER THERMAL POWER PROJECT STAGE-1 (2 X 500 MW)**

TITLE:- **CONFIGURATION DIAGRAM**

REV.NO.	DESCRIPTION	DRAWN	DESIGN	CHKD.	M	E	C	C&I	ARCH.	APPD	DATE
A											30.01.18
					CLEARED BY						

SIZE	SCALE	DRG. NO.	REV. NO.
A4	N.T.S.	3500-404-POI-A-001	A

This document is the property of NATIONAL THERMAL POWER CORPORATION LTD. No part of this document will be reproduced by any means without the written permission.

EXISTING CONTROL SYSTEM U#3

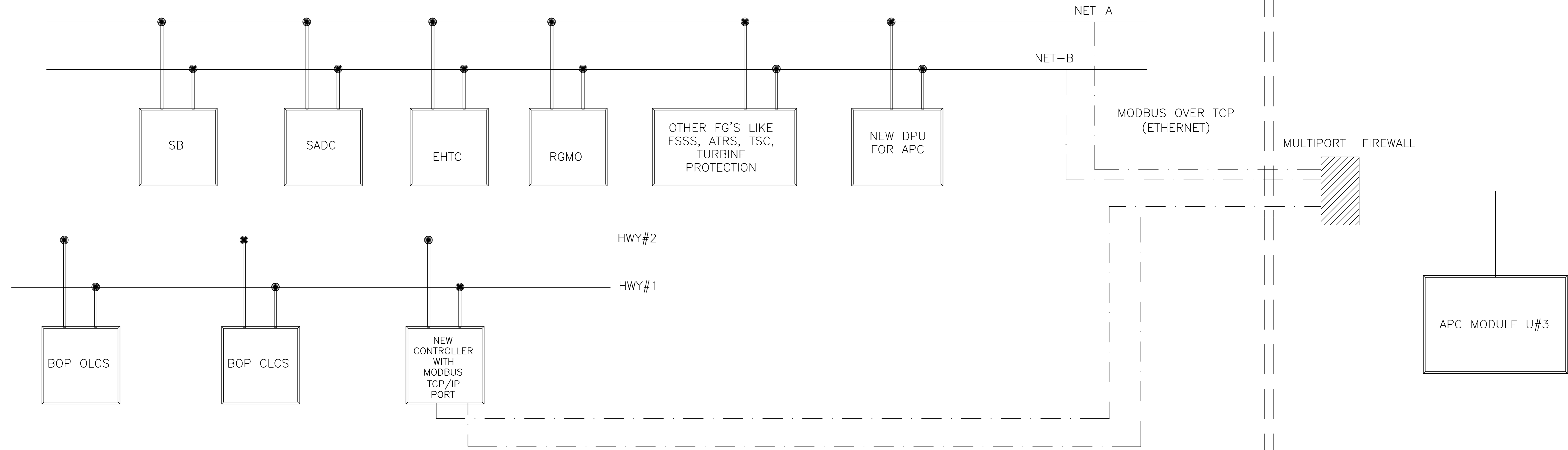

EXISTING CONTROL SYSTEM U#4

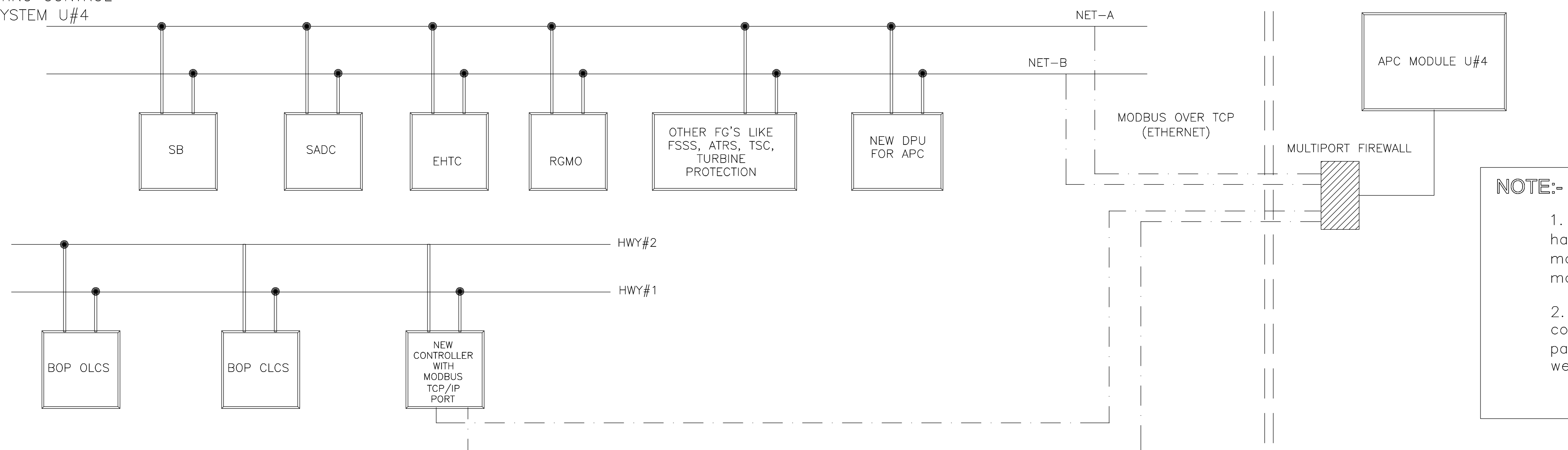

NOTE:-

1. Bidder has to provide individual hardware for APC (includes server, modbus gateway ,firewall (to allow modbus only)) for each unit separately.
2. Bidder has to provide cables & connectors up to employers existing panels where interface cards/switches were mounted.

FOR TENDER PURPOSE ONLY

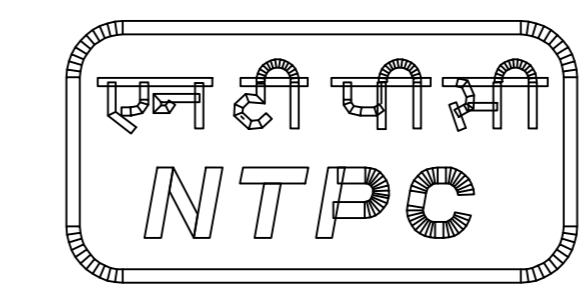

NTPC Limited
(A GOVERNMENT OF INDIA ENTERPRISE)
ENGINEERING DIVISION

REV.NO.	DESCRIPTION	DRAWN	DESIGN	CHKD.	M	E	C	C&I	ARCH.	APPD	DATE
A											30.01.18
					CLEARED BY						

PROJECT:-	SIMHADRI SUPER THERMAL POWER PROJECT STAGE-2 (2 X 500 MW)		
TITLE:-	CONFIGURATION DIAGRAM		
SIZE	SCALE	DRG. NO.	REV. NO.
A4	N.T.S.	3500-404-POI-A-002	A



Volume-I

SECTION - IV

Forms /Bid Data Sheet

**NTPC LIMITED.
CORPORATE MATERIALS
ENGINEERING OFFICE COMPLEX,
A-8A, SECTOR- 24, NOIDA -201301 (UP) INDIA**

Attachment	Description						
Bid Form 1	EMD Bid Submission form						
Bid Form 2	Techno-Commercial Bid Form						
Attachment-1	Proforma of Bank Guarantee for bid security						
Attachment-1A	<table border="1"> <tr> <td>1A (a)</td> <td>Form for Letter of Credit</td> </tr> <tr> <td>1A (b)</td> <td>Form of notification by the employer to the bidder</td> </tr> <tr> <td>1A (c)</td> <td>Form of sight draft</td> </tr> </table>	1A (a)	Form for Letter of Credit	1A (b)	Form of notification by the employer to the bidder	1A (c)	Form of sight draft
1A (a)	Form for Letter of Credit						
1A (b)	Form of notification by the employer to the bidder						
1A (c)	Form of sight draft						
Attachment 2	List of banks who's BG is acceptable for bid security/EMD/CPG						
Attachment 3	<table border="1"> <tr> <td>3A</td> <td>Proforma for Bank Guarantee for Contract Performance</td> </tr> <tr> <td>3B</td> <td>Proforma for Bank Guarantee to be furnished by the associate</td> </tr> <tr> <td>3C</td> <td>Proforma for Bank Guarantee for Advance Payment and Interim Advance Payment</td> </tr> </table>	3A	Proforma for Bank Guarantee for Contract Performance	3B	Proforma for Bank Guarantee to be furnished by the associate	3C	Proforma for Bank Guarantee for Advance Payment and Interim Advance Payment
3A	Proforma for Bank Guarantee for Contract Performance						
3B	Proforma for Bank Guarantee to be furnished by the associate						
3C	Proforma for Bank Guarantee for Advance Payment and Interim Advance Payment						
Attachment 4	Refer Attachment 2						
Attachment 5	Bank Guarantee Verification Check List						
Attachment 6	Form of extension of Bank Guarantee						
Attachment 7	Qualification Data						
Attachment 8	Not Applicable						
Attachment 9	Not Applicable						
Attachment 10	Milestone Schedule						
Attachment 11	Not Applicable						
Attachment 12	E.F.T. Form - Authorization Form for release of payments through Electronic Fund Transfer System duly filled in as per your format enclosed in the Bidding Documents.						
Attachment 12 A	Details of PAN, TIN and Service tax regn for Indian bidders						
Attachment 14	Certificate For Compliance To All Provisions Of Bidding Documents (Certificate of "NIL" Deviation)						
Attachment 15	Form Of Acceptance Of Fraud Prevention Policy						
Attachment 16	Declaration On Banning Policy						
Attachment 17	Not applicable						
Attachment 18	Integrity Pact						
Attachment 19	Not applicable						
Attachment 20	Not applicable						
Attachment 21	Certificate of compliance on qualifying requirement						
Attachment 22	Form of trust receipt for item, equipment and materials received						
Attachment 23	Form of indemnity bond to be executed by the contractor for the equipment handed						

	over by the employer
Attachment 24	Form of Authorisation Letter
Attachment 1P	Details in respect of Local Agent with Fees
Attachment 2P	Bought out items to be directly dispatched by Sub-Vendors to site
Attachment 25	Form of contract agreement

EMD BID SUBMISSION FORM
(To be submitted in Envelope 1 with EMD)

Ref No.

Date

To,
AGM (CM)
NTPC Limited,
Plot A 8A, Sector-24,
Noida - 201301

Dear Sirs,

We have read and examined the bid documents in respect of NIT no. relating to the Package.

We hereby submit our bid as outlined in your bidding document.

- We hereby confirm our acceptance and compliance to the provisions and terms and conditions contained in the bidding documents. We declare that the work will be executed strictly in accordance with the requirement.
- We hereby confirm that we have read the provisions of bidding documents alongwith its subsequent Amendment(s) / Clarification(s) / Addenda/Errata and further confirm that our Bids (i.e. both Techno-Commercial Bid and Price Bid) are strictly in conformity with the provisions of the Bidding Documents including its Amendments/ Clarifications / Errata / Revisions thereof and we have not taken any deviation to any of the provisions of the aforesaid bidding documents.
- We understand that in case the Products and/or Services offered do not meet the Technical requirements, then our bid shall be rejected as Technically non-responsive.

We also confirm that in case we refuse to withdraw additional conditions/deviations/variations/exception, implicit or explicit, found anywhere in the techno-commercial bid, our bid shall be rejected as Technically non-responsive.

We further confirm that if any deviation/variation in any form is found in our Price Bid, the EMD shall be forfeited.

- Further, we agree that the entire work shall be performed as per the Technical Specifications and the provisions of bidding documents.
- We confirm that any deviation/ variation / additional conditions to the provisions of Bidding Documents read in conjunction with its Amendment(s)/Clarification(s)/Addenda/ Errata found anywhere in our Techno-Commercial Bid and Price Bid, implicit or explicit, save those pertaining to rebates offered, stands unconditionally withdrawn, without any cost implication whatsoever to the Owner, failing which the Bid Security be forfeited.
- We hereby confirm that our Techno-Commercial Bid does not contain any Price content entry.
- Further, we confirm that our Price Bid does not contain any matter in respect of Technical and / or Commercial aspects other than the details specifically sought in the price Bid.

- Our proposal shall remain valid for acceptance for a period of 180 days from the date of opening of the 'Technical & Commercial Bid' by NTPC.
- We confirm that the prices quoted by us are firm and shall not be subject to any variation for the entire period of the contract. We confirm that the prices quoted by us in the 'Price Bid' include all taxes, duties and levies payable by us.
- We hereby furnish our 'EMD' comprising the following as per prescribed format by way of BG/DD/LC/BC no. dated for Rs. issued by
- Our 'Technical and Commercial Bid' and 'Price Bid' are being submitted as per provisions of the tender documents.

Yours truly,

Date

Signature.....

Place

Name

Designation

Name of Bidder

Seal

TECHNICAL AND COMMERCIAL BID SUBMISSION FORM
(To be submitted Envelope 2)

Ref No.

Date

To,
AGM (CM)
NTPC Limited,
6th Floor, EOC,
Plot A-8A, Sector-24
Noida201301

Dear Sir,

We hereby submit the following as part of our 'Technical and Commercial Bid' as per prescribed formats which form part of Financial QR:

- i. Appendix A to attachment 7B-1 (if applicable)
- ii. Appendix B to attachment 7B-1 (if applicable)
- iii. Appendix C to attachment 7B-1 (if applicable)
- iv. Appendix A to attachment 7B-2 (if applicable)
- v. Appendix B to attachment 7B-2 (if applicable)
- vi. Appendix C to attachment 7B-2 (if applicable)
- vii. CA certificate (if applicable)

Yours truly,

Date

Signature.....

Place

Name

Designation

Name of Bidder

Seal

PROFORMA OF BANK GUARANTEE FOR BID SECURITY
 ((To be stamped in accordance with Stamp Act)

Bank Guarantee No.....

Date :

To,
NTPC Limited,
Plot A 8A, Sector -24
Noida-201 301
Dist. Gautambudh Nagar, Uttar Pradesh

Dear Sirs,

In accordance with your NIT No. dated M/s.....(***)..... having its registered/Head Office at(hereinafter called the 'Bidder') wish to participate in the said Bid for(name of package)....

As an irrevocable Bank Guarantee against Bid Security for an amount of(*) valid for days from(**), is required to be submitted by the Bidder as a condition precedent for participation in the said bid, which amount is liable to be forfeited on the happening of any contingencies mentioned in the Bidding Documents.

We, the[Name and address of the Bank]..... having our head office at(#)..... guarantee and undertake to pay immediately on demand by NTPC Ltd. (hereinafter called 'the Owner') the amount(*)..... (in figures and words) without any reservation, protest, demand and recourse. Any such demand made by the said 'Owner' shall be conclusive and binding on us irrespective of any dispute or difference raised by the Bidder.

This guarantee shall be irrevocable and shall remain valid up to(@)..... . If any further extension of this guarantee is required, the same shall be extended to such required period (not exceeding one year) on receiving instructions from M/s[Bidders anme]..... on whose behalf guarantee is issued.

In witness whereof the Bank, through its authorized officer has set its hand and stamp on this Day of20..... at

Witness

(1) Signature
 Name
 Official Address

Signature.....
 Name.....
 Designation.....
 Bank's Common Seal.....
 Power of Attorney No.....

(2) Signature
 Name
 Official Address

Note:

1. (*) *The amount shall be as specified in the NIT/Bidding Documents.*
- (**) *This shall be the date of opening of bids.*
- (***) *Write the name and address of the Bidder. In case the bid is submitted by a Joint Venture in terms of Qualifying Requirements, write the name and addresses of all the Joint Venture Partners.*
- (#) Complete mailing address of the Head Office of the Bank to be given.
- (@) This date shall be forty five days beyond the validity of bid.

2. *The Bank Guarantee shall be from a bank as per provisions of bidding documents.*
3. The Stamp Paper of appropriate value shall be as per stamp act purchased in the name of the Bidder/Bank issuing the guarantee.
4. While getting the Bank Guarantee issued, Bidders are required to ensure compliance to the points mentioned in the Bank Guarantee Verification Check List in the bidding documents. Bidders are required to fill up this check List and enclose the same along with the Bank Guarantee.
5. While issuing the physical BGs, the Bidder's Bank shall also send electronic message through secure SFMS (in case of BGs issued from within India) or SWIFT (in case of BGs issued from outside India) to Owner's Beneficiary Bank whose details are provided herein below:

i.	Bank Name	SBI
ii.	Branch	Pragati Vihar, Delhi-110003
iii.	Bank Address	Pragati Vihar, Core 6, Scope Complex, Lodhi Road, New Delhi- 110003
iv.	IFSC Code	SBIN0020511

Bidders are advised to ensure that the message is sent by their Bankers. The Bidders must submit the reference details as part of the bid with the EMD.

BID SECURITY - LETTER OF CREDIT

PROPOSED ISSUING BANK NAME & ADDRESS

IRREVOCABLE STANDBY CREDIT NUMBER & DATE:

Beneficiary: NTPC Limited
6th Floor, Engineering Office Complex Plot No. A-8, Sector 24
Noida, Distt. Gautam Budh Nagar
(U.P.), India Pin -201 301.

Gentlemen :

By the order of :

.....
.....(Name of Bidder)
.....

1. We hereby issue in favour of the Beneficiary our irrevocable credit for the account of.....(hereinafter called the Bidder) for an amount or amounts not to exceed in the aggregate US Dollars (Amount) (Amount written out) available by your drafts at sight and will be effective from(Bid Opening Date)until its expiry date as specified below:
2. Your sight draft(s) in the format attached Exhibit 1 (i.e. Attachment - 1 A(c), Volume-I, Section - IV) must mention our credit number as it appears above, and be accompanied by the Notification by the Employer to the Bidder in the format of attached Exhibit- II (i.e. Attachment - 1 A(b),Volume-I, Section - IV) and be presented to our counters (Name and Address of the counters).....before expiration of this credit.
3. Our counters.....(Name and Address of the counters).....on verification of the documents mentioned in para 2 above shall send the amount to State Bank of India, CAG Branch, Jawahar Vyapar Bhawan, 1, Tolstoy Marg, New Delhi-110001, for credit of amount to Account Number: 10813608669 of Employer
4. This credit shall remain in force upto and including.....and shall be extended from time to time for such period as may be desired by.....(Name of Bidder)... ..on whose behalf this letter of credit has been issued.
5. We are informed that this instrument is being issued in accordance with Invitation for Bids under your Bid Document No. for Package forProject.
6. This credit is subject to the Uniform Customs and Practice for Documentary Credits (2007 Revision), International Chamber of Commerce, Publication Number 600.

7. This is Operative instrument and no confirmation will be sent. We hereby engage with drawers and/or bonafide holders that sight draft drawn and negotiated in conformity with the terms of this credit will be duly honoured on presentation.
8. Any advising and/or confirmation charges and/or negotiating charges of the issuing bank for realisation of proceeds of this Letter of Credit shall be to the account of the bidder.

Very truly yours

ISSUING BANK

AUTHORISED SIGNATURE(S)

@ This date shall be Forty Five (45) days beyond the validity of bid.

FORM OF NOTIFICATION BY THE EMPLOYER TO THE BIDDER

M/s.....

Ref : Your proposal against our IFB No.....
Forfeiture of Bid Guarantee amount.

Dear Sirs,

Whereas you have furnished as a part of your proposal the Bid Guarantee in the form of irrevocable and confirmed Letter of Credit No.....dated.....for a sum of (Bank's name).....payable to...(Name of the Employer) on demand without any reservation, demur or protest, contest and recourse at..... (Name and place of Bank)

In terms of the aforesaid Bid Guarantee, we do hereby forfeit the Guarantee amount.

For.....(Name of the Employer)

(AUTHORISED SIGNATORY)

N.B. The Letter of Credit should not stipulate any other proforma of notification different from this format. No change whatsoever in the said proforma is acceptable to the Employer.

FORM OF SIGHT DRAFT

Drawn under L.C. No.....dated.....

of
(Name of Bank that opened the L.C.)

At sight promptly pay to
(Name of the Bank at which L/C, is negotiable)

..... of order sum of
for payment to the Employer (Amount of L/C)

For..... (Name of the Employer)

(AUTHORISED SIGNATORY)

To,
(Name and Address of the Bank which opened L.C.)

Updated scheduled commercial bank list as on 16.08.2017

LIST OF BANKS WHOSE BANK GUARANTEE IS ACCEPTABLE FOR BID SECURITY/ EMD/CPG

A STATE BANK OF INDIA

B NATIONALISED BANKS

1. Allahabad Bank
2. Andhra Bank
3. Bank of India
4. Bank of Maharashtra
5. Canara Bank
6. Central Bank of India
7. Corporation Bank
8. Dena Bank
9. Indian Bank
10. Indian Overseas Bank
11. Oriental Bank of Commerce
12. Punjab National Bank
13. Punjab & Sind Bank
14. Syndicate Bank
15. Union Bank of India
16. United Bank of India
17. UCO Bank
18. Vijaya Bank
19. Bank of Baroda

C SCHEDULED PRIVATE BANKS (INDIAN BANKS)

1. Catholic Syrian Bank
2. City Union Bank
3. Dhanlaxmi Bank Ltd.
4. Federal Bank Ltd
5. Jammu & Kashmir Bank Ltd
6. Karnataka Bank Ltd
7. Karur Vysya Bank Ltd
8. Lakshmi Vilas Bank Ltd
9. Nainital Bank Ltd
10. Kotak Mahindra Bank
11. RBL Bank Limited
12. South Indian Bank Ltd
13. Tamilnad Mercantile Bank Ltd
14. ING Vysya Bank Ltd
15. Axis Bank Ltd.
16. IndusInd Bank Ltd
17. ICICI Bank
18. HDFC Bank Ltd.

19. DCB Bank Ltd
20. Yes Bank Ltd
21. IDFC Bank Limited
22. Bandhan Bank Limited

D SCHEDULED PRIVATE BANKS (FOREIGN BANKS)

1. Abu Dhabi Commercial Bank PJSC
2. Bank of America NA
3. Bank of Bahrain & Kuwait B.S.C.
4. Mashreq Bank p.s.c.
5. Bank of Nova Scotia
6. Crédit Agricole Corporate and Investment Bank
7. BNP Paribas
8. Barclays Bank
9. Citi Bank N.A.
10. Deutsche Bank A.G.
11. The HongKong Shanghai Banking Corporation Ltd
12. Societe Generale
13. Sonali Bank Ltd.
14. Standard Chartered Bank
15. J.P. Morgan Chase Bank, National Association
16. State Bank of Mauritius Ltd.
17. DBS Bank Ltd.
18. Bank of Ceylon
19. PT Bank Maybank Indonesia TBK
20. A B Bank
21. Shinhan Bank.
22. CTBC Bank Co. Ltd.
23. Mizuho Bank Ltd
24. Krung Thai Bank Public Company Ltd.
25. The Bank of Tokyo-Mitsubishi UFJ Limited.
26. Australia & Newzealand Banking Group Limited
27. Sumitomo Mitsui Banking Corporation
28. American Express Banking Corporation
29. Commonwealth Bank of Australia
30. Credit Suisse A.G.
31. FirstRand Bank Ltd.
32. Industrial & Commercial Bank of China Ltd.
33. JSC VTB Bank
34. National Australia Bank
35. Cooperatieve Rabobank U.A.
36. Sberbank
37. United Overseas Bank Ltd.
38. Westpac Banking Corporation
39. Woori Bank
40. The Royal Bank of Scotland plc
41. Doha Bank Qsc
42. Industrial Bank of Korea
43. KEB Hana Bank
44. National Bank of Abu Dhabi PJSC

E OTHER PUBLIC SECTOR BANKS

1. IDBI Bank Ltd

***Note - Any Addition/ Deletion/ Modification in Bank list shall be as per changes in Second Schedule List by RBI from time to time.**



एन टी पी सी लिमिटेड
(भारत सरकार का उद्यम)

NTPC Limited
(A Govt. of India Enterprise)

केन्द्रीय कार्यालय/Corporate Centre

Date : 03rd September 2014

Ref. No.: NTPC/FC/CS/BG/01
Deputy General Manager,
State Bank of India,
CAG Branch,
12 th floor, Jawahar Vyapar Bhavan, 1, Tolstoy Marg,
New Delhi 110 001

Kind Atten: Sh. Sandeep Mishra

Sub: Format of the Bank Guarantee (BG) issued by State Bank of India – reg.

Dear Sir,

NTPC Limited is India's largest Power Company and a 'Maharatna PSU' with a significant presence in the entire value chain of power generation business. The procurement process of NTPC requires its participating Bidders to submit Bank Guarantees (BGs) as Bid security/other securities in a fixed format provided by NTPC.

It has been observed recently that BGs issued by various branches of State Bank of India are inserting the following additional clause.

QUOTE

Notwithstanding anything contrary contained in any law for the time being in force or banking practice, this guarantee shall not be assignable or transferable by the beneficiary. Notice or invocation by any person such as assignee, transferee or agent of beneficiary shall not be entertained by the bank. Any invocation of guarantee can be made only by the beneficiary directly.

UNQUOTE

The inclusion of the aforesaid clause in the BGs restricts the rights of NTPC under the BG and it may not be possible for NTPC to accept the aforesaid clause in the BGs submitted to us by our Bidders. It may also be mentioned that incorporation of the above additional clause in the BG results in the BG being returned by NTPC and consequently rejection of the bids of parties that have submitted such BGs.

In view of the above, it is requested that please take up at appropriate levels so that suitable instructions are issued to all your branches not to incorporate any such additional clause and henceforth BGs may be issued strictly as per NTPC format only.

Kindly acknowledge the receipt of this letter

Yours faithfully,

(K.P.Gupta)
General Manager (Finance)

Copy for Kind information: ED(CC&M) for kind info of m.s

एन टी पी सी भवन स्कोप कॉम्प्लेक्स, 7, इन्स्टीट्यूशनल एरिया, लोधी रोड, नई दिल्ली-110003 टेल/टैल : 24360100, फैक्स/Fax : 011-24361018
NTPC Bhawan, SCOPE Complex, 7, Institutional Area, Lodhi Road, New Delhi-110003, वेबसाइट/Website : www.ntpc.co.in



भारतीय स्टेट बैंक
State Bank of India

कॉर्पोरेट लेखा समूह शाखा, जवाहर व्यापार भवन,
11-12 वां तल, 1, टॉलस्टोय मार्ग, नई दिल्ली-110 001
Corporate Accounts Group Branch, Jawahar Vyapar Bhawan,
11th & 12th Floor, 1, Tolstoy Marg, New Delhi-110 001

Tel.: 23374525, 23374505, 23374541 (AMT-1), 23353022 (DGM & COO), 23701043, 23359506 (A & A), 23352995 (CS), 23352968 (IB)
Fax: 23353101 (Sectt.), 23352793 (CS), 23353029 (IB)

Shri K.P. Gupta,
General Manager (Finance),
NTPC Limited
Scope Complex, 7, Institutional Area,
Lodhi Road,
New Delhi: 110 003.

CAG-I/AMT-1/2014-15/370

04.09.2014

Dear Sir,

Format of the Bank Guarantee (BG) issued by State Bank of India

We refer to your letter dated 3rd September 2014 wherein you have requested for excluding bidders/vendors of NTPC from insertion of additional Clause restraining assignment/transferability of BG.

Looking at our relationship with NTPC, as a very special case, we have since obtained waiver from our Authorities for excluding NTPC from insertion of the referred clause for BGs issued in your favour.

We are taking steps to issue suitable instructions to our offices for exclusion of this clause for BGs issued in favour of NTPC. In case any bidder or vendor submits to you a Bank Guarantee issued by any of our Branches containing the additional clause as mentioned above, request you to please bring it to our notice and advise us so that we can take-up with the concerned Branch for excluding it.

This is for your information and necessary action please.

Yours faithfully,

(Sandeep Mishra)

Deputy General Manager &
Relationship Manager, AMT-1

PROFORMA FOR BANK GUARANTEE FOR CONTRACT PERFORMANCE

(To be stamped in accordance with Stamp Act)

Bank Guarantee No.....**Date :**

To,
NTPC Limited,
Plot A 8A, Sector -24
Noida-201 301
Dist. Gautambudh Nagar, Uttar Pradesh

Dear Sirs,

In consideration of the NTPC Ltd., (hereinafter referred to as the 'Purchaser' which expression shall unless repugnant to the context or meaning thereof include its successors, administrators and assigns) having awarded to M/s with its Registered/Head Office at (hereinafter referred to as the 'Seller' which expression shall unless repugnant to the context or meaning thereof, includes its successors, administrators, executors & assigns) a Contract by issue of Purchaser's Purchase Order No. dated and the same having been unequivocally accepted by the seller resulting in a 'Contract' valued at for (scope of work/contract) and the seller having agreed to provide a contract performance guarantee of the faithful performance of the entire contract equivalent to ten percent (10%) of the said value of the contract to the purchaser.

We,(Name & Address of Bank)..... having our Head Office at (hereinafter referred to as the 'Bank' which expression shall unless repugnant to the context or meaning thereof, include its successors, administrators, executors & assigns), do hereby guarantee and undertake to pay the Purchaser, on demand any and all monies payable by the Seller to the extent of as aforesaid at any time up to (*) without any demur, reservation contest, recourse, or protest and/or without any reference to the Seller. Any such demand made by the Purchaser on the Bank shall be conclusive and binding notwithstanding any difference between the Purchaser and Seller or any dispute pending before any court Tribunal, Arbitrator or any other Authority. The bank undertakes not to revoke this guarantee during its currency without previous consent of the purchaser and further agrees that this guarantee herein contained shall continue to be enforceable till the purchaser discharges this guarantee.

The Purchaser shall have the fullest liberty without affecting in any way the liability of the Bank under this guarantee, from time to time to extend the time for performance of Contract by the Seller. The Purchaser shall have the fullest liberty, without affecting this guarantee to postpone from time to time the exercise of any powers vested in them or of any right which they might have against the Seller, and to exercise the same at any time in any manner, and either to enforce or to forbear to enforce any covenants, contained or implied in the contract between the Purchaser and the Seller or any other course of remedy or security available to the Purchaser. The Bank shall not be released of its obligations under these presents by any exercise by the Purchaser of its liberty with reference to the matters aforesaid or any of them or by reason of any other act or forbearance or other acts of omission or commission on the part of the purchaser or any other indulgence shown by the Purchaser or by any other matter or thing whatsoever which under law would, but for this provision, have the effect of relieving the Bank.

The Bank also agrees that the purchaser at its option shall be entitled to enforce this guarantee against the bank as a principal debtor, in the first instance without proceeding against the seller and notwithstanding any security or other guarantee that the purchaser may have in relation to the seller's liabilities.

Notwithstanding anything contained hereinabove our liability under this guarantee is restricted to and it shall remain in force up to and including (*)..... and shall be extended from time to time for such period (not exceeding one year), as may be desired by M/s on whose behalf this guarantee has been given.

Dated this day of 20..... at

WITNESS

1) SIGNATURE NAME OFFICIAL ADDRESS	SIGNATURE NAME DESIGNATION BANK'S COMMON SEAL ATTORNEY AS PER POWER OF ATTORNEY NO..... DATE
2) SIGNATURE NAME OFFICIAL ADDRESS	

NOTE :

1. (*) The Date will be Three Months beyond the expiry of the warranty period as specified in the order.
2. *The Bank Guarantee shall be from a bank as per provisions of bidding documents.*
3. While getting the Bank Guarantee issued, the Associate is required to ensure compliance to the points mentioned in Attachment-5 of Bank Guarantee Verification Check List enclosed with the Bidding Documents. Further, the Contractor is required to fill up this Attachment-5 and enclose the same with the Bank Guarantee.
4. The Stamp paper of appropriate value shall be purchased in the name of guarantee issuing bank or the party on whose behalf the BG is being issued. The Bank Guarantee shall be issued on non-judicial Stamp paper of appropriate value as per Stamp act prevailing in the States where the BG is to be submitted or is to be acted upon or the rate prevailing in the state where the BG is executed, whichever is higher.
5. While issuing the physical BGs, the Bidder's Bank shall also send electronic message through secure SFMS (in case of BGs issued from within India) or SWIFT (in case of BGs issued from outside India) to Owner's Beneficiary Bank whose details are provided herein below:

i.	Bank Name	SBI
ii.	Branch	Pragati Vihar, Delhi-110003
iii.	Bank Address	Pragati Vihar, Core 6, Scope Complex, Lodhi Road, New Delhi-110003
iv.	IFSC Code	SBIN0020511
v.	A/C No.	52142904702

Bidders are advised to ensure that the message is sent by their Bankers. The Bidders must submit the reference details as part of the bid with the EMD.

**PROFORMA FOR BANK GUARANTEE
TO BE FURNISHED BY THE ASSOCIATE**

(To be stamped in accordance with the Stamp Act,
if any, of the Country of the issuing Bank) :

Bank Guarantee No.....

Date

In consideration of NTPC Ltd., (hereinafter referred to as "Employer" which expression shall unless repugnant to the context or meaning thereof include its successors, administrators and assigns) having awarded to with its Registered Head Office at.....(herein-after referred to as "Contractor") a Contract for Package vide Contract No. dated.....and the same having been unequivocally accepted by the Contractor resulting in a "Contract", which award is on the strength of Deed of Joint Undertaking dated (hereinafter referred to as "Undertaking") given by M/s * (Contractor) and by (Associate) having its registered office at (hereinafter called Associate), and the Contractor having further executed with (Associate) a Sub-Contract dated and the same having been unequivocally accepted by the Associate resulting in a Sub-Contract Agreement valued at for (hereinafter called "Sub-Contract Agreement") and.....(Associate) having agreed to provide a Performance Guarantee amounting to..... to the Employer on the terms and conditions specified in the "Undertaking".

We..... Bank, having its Head Office (hereinafter referred to as the "Bank", which expression shall, unless repugnant to the context or meaning thereof, include its successors, administrators, executors and assigns) do hereby guarantee and undertake to pay to the Employer on demand any and all monies to the extent of(Specify currency and amount in words and figures) only as aforesaid at any time upto.....@.....without any demur, reservation, context, recourse or protest and/or without any references to "Associate" or "Contractor". Any such demand made by the Employer on the Bank shall be conclusive and binding, notwithstanding any difference between the Employer and Contractor and/or between the Employer and Associate or any dispute pending before any Court, Tribunal, Arbitrator or any other Authority. The Bank undertakes not to revoke this guarantee during its currency without previous consent of the Employer and further agrees that the guarantee herein contained shall be enforceable till ninety (90) days after expiry of its validity.

The Employer shall have the fullest liberty, without affecting in any way the liability of the Bank under this guarantee, from time to time to extend the time for performance of the Contract or the Sub-contract Agreement by the Associate. The Employer shall have the fullest liberty, without affecting this guarantee, to postpone from time to time the exercise of any powers vested in them or of any right which they might have against the Associate and to exercise the same at any time, in any manner, and either to enforce or to forbear to enforce any covenants, contained or implied, in the Contract or Undertaking or any other course or remedy or security available to the Employer. The Bank shall not be released of its obligations under these presents by any exercise of its liberty with reference to the matters aforesaid or any of them or by reason of any other act or forbearance or other acts of omission or commission on the part of the Employer or any other indulgence shown by the Employer or by any other matter or thing whatsoever which under law would, but for this provision have the effect of relieving the Bank from its obligations.

The Bank also agrees that the Employer at its option shall be entitled to enforce this Guarantee against the Bank as a principal debtor, in the first instance without proceeding against Contractor or Associate and

notwithstanding any Security or other Guarantee that the Employer may have in relation to Contractor's or Associate liabilities.

Notwithstanding anything contained hereinabove our liability under this guarantee is restricted to and, it shall remain in force upto and including @ and shall be extended from time to time for such period (not exceeding one year), as may be desired by M/s (Associate/Collaborator/Licensor) on whose behalf this guarantee has been given.

Date this.....day of.....201.....at.....

WITNESS

(Signature).....

(Signature).....

(Name).....

(Name & Designation).....

(Official Address).....

(Bank's Seal).....

Authorised vide Power of
Attorney No.....

Date.....

* Brief Name of the Contractor

@ The date will be ninety (90) days after the end of the Annual Maintenance Contract (AMC) Period of three (03) years (after the completion of warranty period) as specified in contract.

NOTE :

- 1. The Bank Guarantee shall be from a bank as per provisions of bidding documents.***
2. While getting the Bank Guarantee issued, the Associate is required to ensure compliance to the points mentioned in Attachment-5 of Bank Guarantee Verification Check List enclosed with the Bidding Documents. Further, the Contractor is required to fill up this Attachment-5 and enclose the same with the Bank Guarantee.
3. The Stamp paper of appropriate value shall be purchased in the name of guarantee issuing bank or the party on whose behalf the BG is being issued. The Bank Guarantee shall be issued on non-judicial Stamp paper of appropriate value as per Stamp act prevailing in the States where the BG is to be submitted or is to be acted upon or the rate prevailing in the state where the BG is executed, whichever is higher.
4. While issuing the physical BGs, the Bidder's Bank shall also send electronic message through secure SFMS (in case of BGs issued from within India) or SWIFT (in case of BGs issued from outside India) to Owner's Beneficiary Bank whose details are provided herein below:

i	Bank Name	State Bank of Hyderabad
ii	Branch	Pragati Vihar, Delhi-110003

iii	Bank Address	Pragati Vihar,Core 6,Scope Complex,Lodhi Road, New Delhi-110003
iv	IFSC Code	SBHY0020511

Bidders are advised to ensure that the message is sent by their Bankers. The Bidders must submit the reference details as part of the bid with the EMD.

5. In case, the Bank Guarantees are to be submitted towards Security for Deed of Joint Undertaking by the Contractor / Associates(s), are executed by a Foreign Bank outside India and the Bank Guarantee is not executed on Non-judicial Stamp Paper of appropriate value, the same shall have to be got adjudicated and applicable Stamp Duty paid. The legal expenses for aforesaid adjudication and the Stamp Duty shall be borne by the Contractor.
6. The Sub-Contract Agreement shall be the Agreement signed between the Contractor and his Associate.

PROFORMA FOR BANK GUARANTEE FOR CONTRACT PERFORMANCE

(To be stamped in accordance with Stamp Act)

Bank Guarantee No.....**Date :**

To,
NTPC Limited,
Plot A 8A, Sector -24
Noida-201 301
Dist. Gautambudh Nagar, Uttar Pradesh

Dear Sirs,

In consideration of[*Employer's Name*]..... (hereinafter referred to as the 'Employer', which expression shall, unless repugnant to the context or meaning thereof include its successors, administrators and assigns) having awarded to M/s.....[*Contractor's Name*]..... with its Registered/Head Office at (hereinafter referred to as the 'Contractor' which expression shall unless repugnant to the context or meaning thereof, include its successors, administrators, executors and assigns), a Contract, by issue of Employer's Notification of Award No. dated and the same having been unequivocally accepted by the Contractor, resulting into a Contract bearing No. dated..... valued at for [*Name of Contract*](hereinafter called the 'Contract') and the Employer having agreed to make an advance payment to the Contractor for performance of the above Contract amounting (in words and figures) as an Advance against Bank Guarantee to be furnished by the Contractor.

We.....[*Name and address of the Bank*]..... having its Head Office at (hereinafter referred to as the 'Bank', which expression shall, unless repugnant to the context or meaning thereof, include its successors, administrators, executors and assigns) do hereby guarantee and undertake to pay the Employer, immediately on demand any or, all monies payable by the Contractor to the extent of[*advance amount*]..... as aforesaid at any time upto(@)..... without any demur, reservation, contest, recourse or protest and/ or without any reference to the Contractor. Any such demand made by the Employer on the Bank shall be conclusive and binding notwithstanding any difference between the Employer and the Contractor or any dispute pending before any Court, Tribunal, Arbitrator or any other authority. The Bank undertakes not to revoke this guarantee during its currency without previous consent of the Employer and further agrees that the guarantee herein contained shall be enforceable till ninety (90) days after expiry of its validity.

The Employer shall have the fullest liberty without affecting in any way the liability of the Bank under this guarantee, from time to time to vary the advance or to extend the time for performance of the Contract by the Contractor. The Employer shall have the fullest liberty without affecting this guarantee, to postpone from time to time the exercise of any powers vested in them or of any right which they might have against the Contractor, and to exercise the same at any time in any manner, and either to enforce or to forbear to enforce any covenants, contained or implied, in the Contract between the Employer and the Contractor or any other course or remedy or security available to the Employer. The Bank shall not be released of its obligations under these presents by any exercise by the Employer of its liberty with reference to the matters aforesaid or any of them or by reason of any other act or forbearance or other acts of omission or commission on the part of the Employer or any other indulgence shown by the Employer or by any other matter or thing whatsoever which under law would but for this provision, have the effect of relieving the Bank.

The Bank also agrees that the Employer at its option shall be entitled to enforce this Guarantee against the Bank as a principal debtor, in the first instance without proceeding against the Contractor and notwithstanding any security or other guarantee that the Employer may have in relation to the Contractor's liabilities.

Notwithstanding anything contained hereinabove our liability under this guarantee is limited to[advance amount]..... and it shall remain in force upto and including(@)..... and shall be extended from time to time for such period (not exceeding one year), as may be desired by M/s.....[Contractor's Name]..... on whose behalf this guarantee has been given.

Dated this day of 20 at

WITNESS :

<p>1. (Signature)</p> <p>..... (Name)</p> <p>..... (Official Address)</p>	<p>..... (Signature)</p> <p>..... (Name)</p> <p>..... (Designation with Bank Stamp)</p> <p>Authorised Vide Power of Attorney No.....</p> <p>Date.....</p>
<p>2. (Signature)</p> <p>..... (Name)</p> <p>..... (Official Address)</p>	

NOTE :

1. (@) The Date will be Three Months beyond the expiry of the warranty period as specified in the order.
2. The Bank Guarantee shall be from a bank as per provisions of bidding documents.
3. While getting the Bank Guarantee issued, the Associate is required to ensure compliance to the points mentioned in Attachment-5 of Bank Guarantee Verification Check List enclosed with the Bidding Documents. Further, the Contractor is required to fill up this Attachment-5 and enclose the same with the Bank Guarantee.
4. The Stamp paper of appropriate value shall be purchased in the name of guarantee issuing bank or the party on whose behalf the BG is being issued. The Bank Guarantee shall be issued on non-judicial Stamp

paper of appropriate value as per Stamp act prevailing in the States where the BG is to be submitted or is to be acted upon or the rate prevailing in the state where the BG is executed, whichever is higher.

5. While issuing the physical BGs, the Bidder's Bank shall also send electronic message through secure SFMS (in case of BGs issued from within India) or SWIFT (in case of BGs issued from outside India) to Owner's Beneficiary Bank whose details are provided herein below:

i.	Bank Name	SBI
ii.	Branch	Pragati Vihar, Delhi-110003
iii.	Bank Address	Pragati Vihar, Core 6, Scope Complex, Lodhi Road, New Delhi-110003
iv.	IFSC Code	SBIN0020511
v.	A/C No.	52142904702

Bidders are advised to ensure that the message is sent by their Bankers. The Bidders must submit the reference details as part of the bid with the EMD.

BANK GUARANTEE VERIFICATION CHECK LIST

(To be submitted in Envelope 1)

1. **Bank Guarantee No. & Date** :
2. **Name of Issuing Bank** :
3. **Amount of BG** :
4. **Nature of BG & No. of Pages** :
5. **Validity of BG** :
6. **Vendor Reference** :
 - Name
 - Address.....
 - Telephone
 - Fax
 - Email
7. **Bank Reference**
 - Name
 - Address.....
 - Telephone
 - Fax
 - Email

Sl. No.	<i>Details of Checks</i>	Yes/No
1.	Is the BG on Non-judicial stamp paper of appropriate value, as per Stamp Act?	
2.	Whether date, purpose of purchase of stamp paper and name of the purchaser are indicated on the back of stamp paper under the Signature of Stamp Vendor? (The date of purchase of stamp paper should be not later than the date of execution of BG and the stamp paper should be purchased either in the name of the executing Bank or the Bidder on whose behalf the BG has been issued. Also, the stamp paper should not be older than six months from the date of execution of BG).	
3.	In case of BGs from Banks abroad, has the BG been executed on Letter Head of the Bank.	

4.	Has the executing officer of BG indicated his name, designation and Power of Attorney No. / Signing Power No., on the BG?	
5.	Is each page of BG duly signed / initialed by executant and whether stamp of Bank is affixed thereon?	
6.	Whether the last page is signed with full particulars including two witness under seal of Bank as required in the prescribed proforma?	
7.	Does the Bank Guarantee compare verbatim with the Proforma prescribed in the Bidding Documents?	
8.	Are the factual details such as Bidding Documents No. / Specification No., Amount of BG, validity of BG correctly mentioned in the BG?	
9.	Whether overwriting / cutting, if any on the BG have been properly authenticated under signature & seal of executants?	
10.	Whether BG has been issued by a Bank in line with the provisions of Bidding Documents?	
11.	In case BG has been issued by a Bank other than those specified in Bidding Document, is the BG confirmed by a Bank in India acceptable as per Bidding Document?	

Signature of Bidder.....

Name

Designation

Seal

FORM OF EXTENSION OF BANK GUARANTEE
(On Non-judicial stamp paper of same value on which original BG was executed)

Ref. No.:

Date:

To,
NTPC Limited,
EOC, Plot A 8A, Sector -24
Noida-201 301
Dist. Gautambudh Nagar, Uttar Pradesh

Dear Sirs,

Subject: Extension of Bank Guarantee No. _____ dated _____ for _____ [indicate value of
bank guarantee _____ favouring yourselves expiring on _____ on account of M/s
.....(Name of Bidder)..... in respect of Contract for _____ (Insert Package name)
_____, (hereinafter called original Bank Guarantee)

At the request of M/s _____ we _____ Bank branch office at
_____ and having its Head Office at _____ do hereby extend our liability under
the above mentioned Guarantee No. _____ dated _____ for a further period of _____
year/months from _____ to expire on _____.

Except as provided above, all other terms and conditions of original Bank Guarantee No. _____ dated _____ shall remain unaltered and binding.

Please treat this as an integral part of the original guarantee to which it would be deemed to have been attached.

Signature
Name
Designation
Authorised Vide
Power of Attorney No.....

Dated _____

SEAL OF BANK

NIT NO.....

QUALIFICATION DATA

Bidder's Name & Address:

To
AGM (Corporate Materials),
NTPC Limited
Noida - 201301

Dear Sirs,

We seek our qualification and the data in support thereof is enclosed in the following Attachments:

- 1. Attachment 7A : Details pertaining to Qualification of Bidder
- 2. Attachment 7B-1 : Details of Financial Data of Bidder
- 3. Attachment 7B-2 : Details of Financial Data of Associate

We further understand and agree that any misleading or false information furnished by us may result in summary rejection of our bid :

Date : (Signature).....

Place : (Printed Name).....

(Designation).....

(Common Seal).....

Note : 1. The Bidder shall enclose relevant documents like copies of authentic purchase order, completion certificates, agreements etc. supporting the details / data provided in Attachments - 7A to 7C along with annexures to attachments .

NIT NO.....

QUALIFYING REQUIREMENT DETAILS

(Details pertaining to Technical Qualification of the bidder as per Clause No. 7.1.0 of NIT)

**ADVANCED PROCESS CONTROL – (APC) PACKAGE FOR
SIMHADRI STG-I (2X500 MW) & STAGE-II (2x500 MW)
BIDDING DOCUMENT NO. CS-3500-404-2***(Qualification Data to be filled in by bidders who are seeking qualification
as per item No. 7.1.1 of NIT i.e. Route-1)*

Bidder's Name & Address:

To
AGM (Corporate Materials),
NTPC Limited
Noida - 201301

Dear Sirs,

- I. We confirm that we meet the qualifying requirements specified in Item No. 7.1.1 of NIT.

In this regard we declare that we have Engineered, Manufactured, Supplied, Erected/Supervised Erection & Commissioned/Supervised commissioning of ***Distributed Digital Control, Monitoring & Information system (DDCMIS) /*Distributed Control System (DCS)** which has been in successful operation in at least one (1) unit of coal fired station having unit rating of 200 MW or above for a period of not less than one (1) year prior to the date of bid opening, the details of which are given below.

In this regard, we further declare that we or our group company have an established DDCMIS hardware and software service centre in India working for at least five (5) years prior to the date of bid opening, the details of which are given below.

S.No.	Description	Plant No. 1
1.	Name of client with full Address, Fax No., Telephone No. and E-mail address	
2.	Name of Power Station (Location and Address)	
3.	Name of Package/Contract along with Order/LOA No. & Date	
4.	Name & Address of the Contractor on whom the order for executing the reference plant system was placed by the Owner of the reference plant	
5.	In case the Bidder is not the Contractor at Sl. No. 4 above, Name & Address of the Organisation which placed order for reference plant system on the Bidder.	

6.	Unit Rating (MW)	
7.	Whether coal fired station	*Yes/No
8.	Control & Instrumentation Systems - Distributed Digital, Control, Monitoring & Information System (DDCMIS)/ Distributed Control System (DCS).	
8a.	Scope of work included in the bidder's order	
	(a) Engineering	*Yes/No
	(b) Manufacturing	*Yes/No
	(c) supply	*Yes/No
	(d) Erection	*Yes/No
	(e) Commissioning	*Yes/No
8b.	Total No. of Functional Groups	
8c.	Whether the control system includes	
	a. Modulating control for Steam Generator (SG)	*Yes/No
	b. Modulating control for feed water/condensate cycle	*Yes/No
	c. Binary control of the auxiliaries for Steam Generator (SG)	*Yes/No
	d. Binary control of the auxiliaries for Turbine Generator(TG)	*Yes/No
8d.	Actual date of commissioning	
8e.	No. of years in successful operation as on date of bid opening	
9.	Following documents are enclosed in support of meeting the stipulated Qualifying Requirements for this reference plant	
	a) Relevant portion of Letter of Award/Contract Agreement/ Order	*Yes/No
	b) End-user Certificate	*Yes/No

S.No.	Description	Details
1.	Name & Address of the DDCMIS hardware and software service centre in India	
2.	DDCMIS hardware and software service centre in India owned by	*Bidder/its group company
3.	Relationship between Bidder and its group company if applicable	
4.	Date of establishment of the above office	

II. We confirm that we meet the qualifying requirements specified in Item No. 7.1.1 (B) (B1) of NIT. In this regard we declare that we have supplied and commissioned **Advanced Process Control software for Combustion optimization**, in closed loop which has been in successful operation in at least one (1) unit of pulverized coal fired station having unit rating of 200 MW or above, for a period of not less than one (1) year prior to the date of bid opening, the details of which are given below:

S.No.	Description	Plant No. 1	Supporting Document
1.	Name of client with full Address Fax No., Telephone No. and e-mail address		
2.	Name of Power Stations (Location and Address)		
3.	a) Name of Package/Contract b) Order/LOA No. c) Date	a) b) c)	
4.	Name & Address of the Contractor on whom the order for executing the reference plant system was placed by the Owner of the reference plant		
5.	In case the Bidder is not the Contractor at Sl. No. 4 above, Name & Address of the Organisation which placed order for reference plant system on the Bidder.		
6.	Unit Rating (MW)		
7.	Unit No./Name		
8.	Whether pulverized coal fired station.	*Yes/No	
9.	The solution is Advanced Process Control Software. i.e. Advanced Process Control (APC) shall mean the set of techniques which use a multiple input multiple output predictive model for improving the existing performance of the control loops w.r.t the desired objective (i.e. efficiency improvement or emissions reduction etc). The model can be first principles based, empirical or ANN (artificial neural network) or fuzzy logic based.	*Yes/No	
10.	Scope of work included in the bidder's order (a) Supplied (b) Commissioned	*Yes/No *Yes/No	
11.	a) Name of the Combustion optimization offered for this package b) Version of Combustion optimization offered for this package c) Name of Combustion optimization	a) b) c)	

	<p>provided in the reference Plant</p> <p>d) Version of Combustion optimization provided in the reference Plant</p> <p>e) Whether Combustion optimization offered for this package is same as that in the reference plant or,</p> <p>or is newer versions or upgrades of the same product,</p> <p>or is a product whose name has been changed after version/product upgrade.</p>	<p>d)</p> <p>e) Tick whichever is applicable <input type="checkbox"/> Yes, Is Same <input type="checkbox"/> Yes, Is newer version or upgrades of the same product <input type="checkbox"/> Yes, Is a product whose name has been changed after version/product upgrade</p>	
12.	Whether Combustion optimization includes optimizing the flue gas O2 trim, air registers, and feeder rate bias in order to improve heat rate/ reduce NOx.	*Yes/No	
13.	Whether Combustion optimization is implemented in closed loop in the reference plant	*Yes/No	
14.	Successful operation		
14a.	What was the desired benefit of End-user from Combustion optimization		
14b.	Whether End-user achieved the desired benefit	*Yes/No	
15.	Actual date of commissioning		
16.	No. of years in successful operation prior to the date of bid opening.		
17.	<p>Following documents are enclosed in support of meeting the stipulated Qualifying Requirements for this reference plant:</p> <p>a) Relevant portion of Letter of Award/Contract Agreement/Order</p> <p>b) End user certificate / End User Communication through mail</p> <p>c) Standard Product Catalogue/Manual indicating the Product Lifecycle</p>	<p>*Yes/No</p> <p>*Yes/No</p> <p>*Yes/No</p>	

III. We confirm that we meet the qualifying requirements specified in Item No. 7.1.1 (B) (B2) of NIT. In this regard we declare that we have supplied and commissioned **Advanced Process Control software for Soot Blowing Optimization**, in closed loop which has been in successful operation in at least one (1) unit of pulverized coal fired station having unit rating of 200 MW or above, for a period of not less than one (1) year prior to the date of bid opening., the details of which are given below:

S.No.	Description	Plant No. 1	Supporting Document
1.	Name of client with full Address Fax No., Telephone No. and e-mail address		
2.	Name of Power Stations (Location and Address)		
3.	a) Name of Package/Contract b) Order/LOA No. c) Date	a) b) c)	
4.	Name & Address of the Contractor on whom the order for executing the reference plant system was placed by the Owner of this reference plant		
5.	In case the Bidder is not the Contractor at Sl. No. 4 above, Name & Address of the Organisation which placed order for reference plant system on the Bidder.		
6.	Unit Rating (MW)		
7.	Unit No./Name		
8.	Whether pulverized coal fired station.	*Yes/No	
9.	The solution is Advanced Process Control Software. i.e. Advanced Process Control (APC) shall mean the set of techniques which use a multiple input multiple output predictive model for improving the existing performance of the control loops w.r.t the desired objective (i.e. efficiency improvement or emissions reduction etc). The model can be first principles based, empirical or ANN (artificial neural network) or fuzzy logic based.	*Yes/No	
10.	Scope of work included in the bidder's order (a) Supplied (b) Commissioned	*Yes/No *Yes/No	
11.	a) Name of the Soot Blowing optimization offered for this package b) Version of Soot Blowing optimization offered for this package c) Name of Soot Blowing optimization provided in the reference Plant d) Version of Soot Blowing optimization provided in the reference Plant	a) b) c) d)	

	e) Whether Soot Blowing optimization offered for this package is same as that in the reference plant, or is newer versions or upgrades of the same product, or is a product whose name has been changed after version/product upgrade.	e) Tick whichever is applicable <input type="checkbox"/> Yes, Is Same <input type="checkbox"/> Yes, Is newer version or upgrades of the same product <input type="checkbox"/> Yes, Is a product whose name has been changed after version/product upgrade	
12.	Whether Soot Blowing optimization is implemented in closed loop in the reference plant.	*Yes/No	
13.	Successful operation		
13a.	What was the desired benefit of End-user from Soot Blowing optimization		
13b.	Whether End-user achieved the desired benefit	*Yes/No	
14.	Actual date of commissioning		
15.	No. of years in successful operation prior to the date of bid opening.		
16.	Following documents are enclosed in support of meeting the stipulated Qualifying Requirements for this reference plant: a) Relevant portion of Letter of Award/Contract Agreement/Order b) End user certificate / End User Communication through mail c) Standard Product Catalogue/Manual indicating the Product Lifecycle	*Yes/No *Yes/No *Yes/No	

IV. We confirm that we meet the qualifying requirements specified in Item No. 7.1.1 (B) (B3) of NIT. In this regard we declare that we have supplied and commissioned **Advanced Process Control software for**

Faster load Ramp-up/Ramp-down, in closed loop which has been in successful operation in at least one (1) unit of pulverized coal fired station having unit rating of 200 MW or above, for a period of not less than one (1) year prior to the date of bid opening.

OR

SH/RH Temperature Excursion Reduction, in closed loop which has been in successful operation in at least one (1) unit of pulverized coal fired station having unit rating of 200 MW or above, for a period of not less than one (1) year prior to the date of bid opening.

The details of which are given below:

S.No.	Description	Plant No. 1	Supporting Document
1.	Name of client with full Address Fax No., Telephone No. and e-mail address		
2.	Name of Power Stations (Location and Address)		
3.	a) Name of Package/Contract b) Order/LOA No. c) Date	a) b) c)	
4.	Name & Address of the Contractor on whom the order for executing the reference plant system was placed by the Owner of the reference plant		
5.	In case the Bidder is not the Contractor at Sl. No. 4 above, Name & Address of the Organisation which placed order for reference plant system on the Bidder.		
6.	Unit Rating (MW)		
7.	Unit No./Name		
8.	Whether pulverized coal fired station.	*Yes/No	
9.	The solution is Advanced Process Control Software. i.e. Advanced Process Control (APC) shall mean the set of techniques which use a multiple input multiple output predictive model for improving the existing performance of the control loops w.r.t the desired objective (i.e. efficiency improvement or emissions reduction etc). The model can be first principles based, empirical or ANN (artificial neural network) or fuzzy logic based.	*Yes/No	
10.	The APC software offered was for: a) Faster load Ramp-up/Ramp-down which means using APC for main steam pressure control loop. b) SH/RH Temperature Excursion Reduction which means using APC for SH/RH spray control loop.	*Yes/No *Yes/No	
11.	Scope of work included in the bidder's order (a) Supplied (b) Commissioned	*Yes/No *Yes/No	
12.	a) Name of the APC Software offered for this package b) Version of APC software offered for this	a) b)	

	<p>package</p> <p>c) Name of APC software provided in the reference Plant</p> <p>d) Version of APC software provided in the reference Plant</p> <p>e) Whether APC software offered for this package is same as that in the reference plant,</p> <p>or is newer versions or upgrades of the same product,</p> <p>or is a product whose name has been changed after version/product upgrade.</p>	<p>c)</p> <p>d)</p> <p>e) Tick whichever is applicable <input type="checkbox"/> Yes, Is Same <input type="checkbox"/> Yes, Is newer version or upgrades of the same product <input type="checkbox"/> Yes, Is a product whose name has been changed after version/product upgrade</p>	
13.	Whether the APC software for Faster load ramp-up/ramp-down or SH/RH Temperature excursion reduction is implemented in closed loop in the reference plant	*Yes/No	
14.	Successful operation		
14a.	What was the desired benefit of End-user from the APC software		
14b.	Whether End-user achieved the desired benefit	*Yes/No	
15.	Actual date of commissioning		
16.	No. of years in successful operation prior to the date of bid opening.		
17.	<p>Following documents are enclosed in support of meeting the stipulated Qualifying Requirements for this reference plant:</p> <p>a) Relevant portion of Letter of Award/Contract Agreement/Order</p> <p>b) End user certificate / End User Communication through mail</p> <p>c) Standard Product Catalogue/Manual indicating the Product Lifecycle</p>	<p>*Yes/No</p> <p>*Yes/No</p> <p>*Yes/No</p>	

Date: (Signature)

Place: (Printed Name)

(Designation)

(Common Seal)

Note: 1. Bidders seeking qualification as per clause no 7.1.1 (A) and 7.1.1 (B) of NIT are required to fill-up the details under Sl. No. I ,II ,III & IV and shall strictly follow the above format while filling this Attachment to establish their meeting the Qualification Requirement.

2. Copies of Order/Letter of Award/Client Certificate from the clients, etc. are to be enclosed clearly establishing the scope of work/ years of successful operation, etc. in support of meeting the Qualifying Requirements.

* Bidder to strike out whichever is not applicable

NIT NO.....

QUALIFYING REQUIREMENT DETAILS

(Details pertaining to Technical Qualification of the bidder as per Clause No. 7.1.0 of NIT)

**ADVANCED PROCESS CONTROL – (APC) PACKAGE FOR
SIMHADRI STG-I (2X500 MW) & STAGE-II (2x500 MW)
BIDDING DOCUMENT NO. CS-3500-404-2**

*(Qualification Data to be filled in by bidders who are seeking qualification
as per item No. 7.1.2 of NIT i.e. Route-2)*

Bidder's Name & Address:

To
AGM (Corporate Materials),
NTPC Limited
Noida - 201301

Dear Sirs,

- I. We confirm that we meet the qualifying requirements specified in Item No. 7.1.1 (A) of NIT.

In this regard we declare that we have engineered, manufactured, supplied, erected/supervised erection & commissioned/supervised commissioning of ***Distributed Digital Control, Monitoring & Information system (DDCMIS) /*Distributed Control System (DCS)** which has been in successful operation in at least one (1) unit of coal fired station having unit rating of 200 MW or above for a period of not less than one (1) year prior to the date of bid opening, the details of which are given below.

In this regard, we further declare that we or our group company have an established DDCMIS hardware and software service centre in India working for at least five (5) years prior to the date of bid opening, the details of which are given below.

S.No.	Description	Plant No. 1
1.	Name of client with full Address, Fax No., Telephone No. and E-mail address	
2.	Name of Power Station (Location and Address)	
3.	Name of Package/Contract along with Order/LOA No. & Date	
4.	Name & Address of the Contractor on whom the order for executing the reference plant system was placed by the Owner of the reference plant	
5.	In case the Bidder is not the Contractor at Sl. No. 4 above, Name & Address of the Organisation which placed order for reference plant system on the Bidder.	

6.	Unit Rating (MW)	
7.	Whether coal fired station	*Yes/No
8.	Control & Instrumentation Systems - Distributed Digital, Control, Monitoring & Information System (DDCMIS)/ Distributed Control System (DCS).	
8a.	Scope of work included in the bidder's order	
	(a) Engineering	*Yes/No
	(b) Manufacturing	*Yes/No
	(c) supply	*Yes/No
	(d) Erection	*Yes/No
	(e) Commissioning	*Yes/No
8b.	Total No. of Functional Groups	
8c.	Whether the control system includes	
	e. Modulating control for Steam Generator (SG)	*Yes/No
	f. Modulating control for feed water/condensate cycle	*Yes/No
	g. Binary control of the auxiliaries for Steam Generator (SG)	*Yes/No
	h. Binary control of the auxiliaries for Turbine Generator(TG)	*Yes/No
8d.	Actual date of commissioning	
8e.	No. of years in successful operation as on date of bid opening	
9.	Following documents are enclosed in support of meeting the stipulated Qualifying Requirements for this reference plant	
	a) Relevant portion of Letter of Award/Contract Agreement/ Order	*Yes/No
	b) End-user Certificate	*Yes/No

S.No.	Description	Details
1.	Name & Address of the DDCMIS hardware and software service centre in India	
2.	DDCMIS hardware and software service centre in India owned by	*Bidder/its group company
3.	Relationship between Bidder and its group company if applicable	
4.	Date of establishment of the above office	

II. We confirm that we meet the qualifying requirements specified in Item No. 7.1.1(B) (B1) of NIT. In this regard we declare that we have supplied and commissioned **Advanced Process Control software for Combustion optimization**, in closed loop which has been in successful operation in at least one (1) unit of pulverized coal fired station having unit rating of 200 MW or above, for a period of not less than one (1) year prior to the date of bid opening, the details of which are given below:

S.No.	Description	Plant No. 1	Supporting Document
1.	Name of client with full Address Fax No., Telephone No. and e-mail address		
2.	Name of Power Stations (Location and Address)		
3.	a) Name of Package/Contract b) Order/LOA No. c) Date	a) b) c)	
4.	Name & Address of the Contractor on whom the order for executing the reference plant system was placed by the Owner of the reference plant		
5.	In case the Bidder is not the Contractor at Sl. No. 4 above, Name & Address of the Organisation which placed order for reference plant system on the Bidder.		
6.	Unit Rating (MW)		
7.	Unit No./Name		
8.	Whether pulverized coal fired station.	*Yes/No	
9.	The solution is Advanced Process Control Software. i.e. Advanced Process Control (APC) shall mean the set of techniques which use a multiple input multiple output predictive model for improving the existing performance of the control loops w.r.t the desired objective (i.e. efficiency improvement or emissions reduction etc). The model can be first principles based, empirical or ANN (artificial neural network) or fuzzy logic based.	*Yes/No	
10.	Scope of work included in the bidder's order (a) Supplied (b) Commissioned	*Yes/No *Yes/No	
11.	a) Name of the Combustion optimization offered for this package b) Version of Combustion optimization offered for this package c) Name of Combustion optimization	a) b) c)	

	<p>provided in the reference Plant</p> <p>d) Version of Combustion optimization provided in the reference Plant</p> <p>e) Whether Combustion optimization offered for this package is same as that in the reference plant or,</p> <p>or is newer versions or upgrades of the same product,</p> <p>or is a product whose name has been changed after version/product upgrade.</p>	<p>d)</p> <p>e) Tick whichever is applicable <input type="checkbox"/> Yes, Is Same <input type="checkbox"/> Yes, Is newer version or upgrades of the same product <input type="checkbox"/> Yes, Is a product whose name has been changed after version/product upgrade</p>	
12.	Whether Combustion optimization includes optimizing the flue gas O2 trim, air registers, and feeder rate bias in order to improve heat rate/ reduce NOx.	*Yes/No	
13.	Whether Combustion optimization is implemented in closed loop in the reference plant	*Yes/No	
14.	Successful operation		
14a.	What was the desired benefit of End-user from Combustion optimization		
14b.	Whether End-user achieved the desired benefit	*Yes/No	
15.	Actual date of commissioning		
16.	No. of years in successful operation prior to the date of bid opening.		
17.	<p>Following documents are enclosed in support of meeting the stipulated Qualifying Requirements for this reference plant:</p> <p>a) Relevant portion of Letter of Award/Contract Agreement/Order</p> <p>b) End user certificate / End User Communication through mail</p> <p>c) Standard Product Catalogue/Manual indicating the Product Lifecycle</p>	<p>*Yes/No</p> <p>*Yes/No</p> <p>*Yes/No</p>	

III. We confirm that we meet the qualifying requirements specified in Item No. 7.1.1 (B) (B2) of NIT. In this regard we declare that we have supplied and commissioned **Advanced Process Control software for Soot Blowing Optimization**, in closed loop which has been in successful operation in at least one (1) unit of pulverized coal fired station having unit rating of 200 MW or above, for a period of not less than one (1) year prior to the date of bid opening., the details of which are given below:

S.No.	Description	Plant No. 1	Supporting Document
1.	Name of client with full Address Fax No., Telephone No. and e-mail address		
2.	Name of Power Stations (Location and Address)		
3.	a) Name of Package/Contract b) Order/LOA No. c) Date	a) b) c)	
4.	Name & Address of the Contractor on whom the order for executing the reference plant system was placed by the Owner of this reference plant		
5.	In case the Bidder is not the Contractor at Sl. No. 4 above, Name & Address of the Organisation which placed order for reference plant system on the Bidder.		
6.	Unit Rating (MW)		
7.	Unit No./Name		
8.	Whether pulverized coal fired station.	*Yes/No	
9.	The solution is Advanced Process Control Software. i.e. Advanced Process Control (APC) shall mean the set of techniques which use a multiple input multiple output predictive model for improving the existing performance of the control loops w.r.t the desired objective (i.e. efficiency improvement or emissions reduction etc). The model can be first principles based, empirical or ANN (artificial neural network) or fuzzy logic based.	*Yes/No	
10.	Scope of work included in the bidder's order (a) Supplied (b) Commissioned	*Yes/No *Yes/No	
11.	a) Name of the Soot Blowing optimization offered for this package b) Version of Soot Blowing optimization offered for this package c) Name of Soot Blowing optimization provided in the reference Plant d) Version of Soot Blowing optimization provided in the reference Plant	a) b) c) d)	

	e) Whether Soot Blowing optimization offered for this package is same as that in the reference plant, or is newer versions or upgrades of the same product, or is a product whose name has been changed after version/product upgrade.	e) Tick whichever is applicable <input type="checkbox"/> Yes, Is Same <input type="checkbox"/> Yes, Is newer version or upgrades of the same product <input type="checkbox"/> Yes, Is a product whose name has been changed after version/product upgrade	
12.	Whether Soot Blowing optimization is implemented in closed loop in the reference plant.	*Yes/No	
13.	Successful operation		
13a.	What was the desired benefit of End-user from Soot Blowing optimization		
13b.	Whether End-user achieved the desired benefit	*Yes/No	
14.	Actual date of commissioning		
15.	No. of years in successful operation prior to the date of bid opening.		
16.	Following documents are enclosed in support of meeting the stipulated Qualifying Requirements for this reference plant: a) Relevant portion of Letter of Award/Contract Agreement/Order b) End user certificate / End User Communication through mail c) Standard Product Catalogue/Manual indicating the Product Lifecycle	*Yes/No *Yes/No *Yes/No	

IV. We confirm that we meet the qualifying requirements specified in Item No. 7.1.1 (B) (B3) of NIT. In this regard we declare that we have supplied and commissioned **Advanced Process Control software for**

Faster load Ramp-up/Ramp-down, in closed loop which has been in successful operation in at least one (1) unit of pulverized coal fired station having unit rating of 200 MW or above, for a period of not less than one (1) year prior to the date of bid opening.

OR

SH/RH Temperature Excursion Reduction, in closed loop which has been in successful operation in at least one (1) unit of pulverized coal fired station having unit rating of 200 MW or above, for a period of not less than one (1) year prior to the date of bid opening.

The details of which are given below:

S.No.	Description	Plant No. 1	Supporting Document
1.	Name of client with full Address Fax No., Telephone No. and e-mail address		
2.	Name of Power Stations (Location and Address)		
3.	a) Name of Package/Contract b) Order/LOA No. c) Date	a) b) c)	
4.	Name & Address of the Contractor on whom the order for executing the reference plant system was placed by the Owner of the reference plant		
5.	In case the Bidder is not the Contractor at Sl. No. 4 above, Name & Address of the Organisation which placed order for reference plant system on the Bidder.		
6.	Unit Rating (MW)		
7.	Unit No./Name		
8.	Whether pulverized coal fired station.	*Yes/No	
9.	The solution is Advanced Process Control Software. i.e. Advanced Process Control (APC) shall mean the set of techniques which use a multiple input multiple output predictive model for improving the existing performance of the control loops w.r.t the desired objective (i.e. efficiency improvement or emissions reduction etc). The model can be first principles based, empirical or ANN (artificial neural network) or fuzzy logic based.	*Yes/No	
10.	The APC software offered was for: a) Faster load Ramp-up/Ramp-down which means using APC for main steam pressure control loop. b) SH/RH Temperature Excursion Reduction which means using APC for SH/RH spray control loop.	*Yes/No *Yes/No	
11.	Scope of work included in the bidder's order (a) Supplied (b) Commissioned	*Yes/No *Yes/No	
12.	a) Name of the APC Software offered for this package b) Version of APC software offered for this	a) b)	

	<p>package</p> <p>c) Name of APC software provided in the reference Plant</p> <p>d) Version of APC software provided in the reference Plant</p> <p>e) Whether APC software offered for this package is same as that in the reference plant,</p> <p>or is newer versions or upgrades of the same product,</p> <p>or is a product whose name has been changed after version/product upgrade.</p>	<p>c)</p> <p>d)</p> <p>e) Tick whichever is applicable <input type="checkbox"/> Yes, Is Same <input type="checkbox"/> Yes, Is newer version or upgrades of the same product <input type="checkbox"/> Yes, Is a product whose name has been changed after version/product upgrade</p>	
13.	Whether the APC software for Faster load ramp-up/ramp-down or SH/RH Temperature excursion reduction is implemented in closed loop in the reference plant	*Yes/No	
14.	Successful operation		
14a.	What was the desired benefit of End-user from the APC software		
14b.	Whether End-user achieved the desired benefit	*Yes/No	
15.	Actual date of commissioning		
16.	No. of years in successful operation prior to the date of bid opening.		
17.	<p>Following documents are enclosed in support of meeting the stipulated Qualifying Requirements for this reference plant:</p> <p>a) Relevant portion of Letter of Award/Contract Agreement/Order</p> <p>b) End user certificate / End User Communication through mail</p> <p>c) Standard Product Catalogue/Manual indicating the Product Lifecycle</p>	<p>*Yes/No</p> <p>*Yes/No</p> <p>*Yes/No</p>	

V. In line with meeting the qualifying requirements specified in Item No. 7.1.2 of NIT, we have associated with M/s **(Name of Associate)** whose address is **(Address of Associate)** who meets the requirement of Item no. 7.1.1 (B) (B1) of NIT. We confirm that our associate has supplied and commissioned **Advanced Process Control software for Combustion optimization**, in closed loop which has been in successful operation in at least

one (1) unit of pulverized coal fired station having unit rating of 200 MW or above, for a period of not less than one (1) year prior to the date of bid opening, the details of which are given below:

S.No.	Description	Plant No. 1	Supporting Document
1.	Name of client with full Address Fax No., Telephone No. and e-mail address		
2.	Name of Power Stations (Location and Address)		
3.	a) Name of Package/Contract b) Order/LOA No. c) Date	a) b) c)	
4.	Name & Address of the Contractor on whom the order for executing the reference plant system was placed by the Owner of the reference plant		
5.	In case the Associate is not the Contractor at Sl. No. 4 above, Name & Address of the Organisation which placed order for reference plant system on the Associate .		
6.	Unit Rating (MW)		
7.	Unit No./Name		
8.	Whether pulverized coal fired station.	*Yes/No	
9.	The solution is Advanced Process Control Software. i.e. Advanced Process Control (APC) shall mean the set of techniques which use a multiple input multiple output predictive model for improving the existing performance of the control loops w.r.t the desired objective (i.e. efficiency improvement or emissions reduction etc). The model can be first principles based, empirical or ANN (artificial neural network) or fuzzy logic based.	*Yes/No	
10.	Scope of work included (a) Supplied (b) Commissioned	*Yes/No *Yes/No	
11.	a) Name of the Combustion optimization offered for this package b) Version of Combustion optimization offered for this package c) Name of Combustion optimization provided in the reference Plant d) Version of Combustion optimization provided in the reference Plant	a) b) c) d)	

	e) Whether Combustion optimization offered for this package is same as that in the reference plant or, or is newer versions or upgrades of the same product, or is a product whose name has been changed after version/product upgrade..	e) Tick whichever is applicable <input type="checkbox"/> Yes, Is Same <input type="checkbox"/> Yes, Is newer version or upgrades of the same product <input type="checkbox"/> Yes, Is a product whose name has been changed after version/product upgrade	
12.	Whether Combustion optimization includes optimizing the flue gas O2 trim, air registers, and feeder rate bias in order to improve heat rate/ reduce NOx.	*Yes/No	
13.	Whether Combustion optimization is implemented in closed loop in the reference plant	*Yes/No	
14.	Successful operation		
14a.	What was the desired benefit of End-user from Combustion optimization		
14b.	Whether End-user achieved the desired benefit	*Yes/No	
15.	Actual date of commissioning		
16.	No. of years in successful operation prior to the date of bid opening.		
17.	Following documents are enclosed in support of meeting the stipulated Qualifying Requirements for this reference plant: a) Relevant portion of Letter of Award/Contract Agreement/Order b) End user certificate / End User Communication through mail c) Standard Product Catalogue/Manual indicating the Product Lifecycle	*Yes/No *Yes/No *Yes/No	

VI. In line with meeting the qualifying requirements specified in Item No. 7.1.2 of NIT, we have associated with M/s **(Name of Associate)** whose address is **(Address of Associate)** who meets the requirement of clause 7.1.1 (B) (B2) of NIT. We confirm that our associate has supplied and commissioned **Advanced Process Control software for Soot Blowing Optimization**, in closed loop which have been in successful operation in at least one (1) unit of pulverized coal fired station having unit rating of 200 MW or above, for a period of not less than one (1) year prior to the date of bid opening., the details of which are given below:

S.No.	Description	Plant No. 1	Supporting
-------	-------------	-------------	------------

			Document
1.	Name of client with full Address Fax No., Telephone No. and e-mail address		
2.	Name of Power Stations (Location and Address)		
3.	a) Name of Package/Contract b) Order/LOA No. c) Date	a) b) c)	
4.	Name & Address of the Contractor on whom the order for executing the reference plant system was placed by the Owner of this reference plant		
5.	In case the Associate is not the Contractor at Sl. No. 4 above, Name & Address of the Organisation which placed order for reference plant system on the Associate.		
6.	Unit Rating (MW)		
7.	Unit No./Name		
8.	Whether pulverized coal fired station.	*Yes/No	
9.	The solution is Advanced Process Control Software. i.e. Advanced Process Control (APC) shall mean the set of techniques which use a multiple input multiple output predictive model for improving the existing performance of the control loops w.r.t the desired objective (i.e. efficiency improvement or emissions reduction etc). The model can be first principles based, empirical or ANN (artificial neural network) or fuzzy logic based.	*Yes/No	
10.	Scope of work included in the bidder's order (a) Supplied (b) Commissioned	*Yes/No *Yes/No	
11.	a) Name of the Soot Blowing optimization offered for this package b) Version of Soot Blowing optimization offered for this package c) Name of Soot Blowing optimization provided in the reference Plant d) Version of Soot Blowing optimization provided in the reference Plant e) Whether Soot Blowing optimization offered for this package is same as that in	a) b) c) d) e) Tick whichever is applicable	

	<p>the reference plant,</p> <p>or is newer versions or upgrades of the same product,</p> <p>or is a product whose name has been changed after version/product upgrade.</p>	<input type="checkbox"/> Yes, Is Same <input type="checkbox"/> Yes, Is newer version or upgrades of the same product <input type="checkbox"/> Yes, Is a product whose name has been changed after version/product upgrade	
12.	Whether Soot Blowing optimization is implemented in closed loop in the reference plant.	*Yes/No	
13.	Successful operation		
13a.	What was the desired benefit of End-user from Soot Blowing optimization		
13b.	Whether End-user achieved the desired benefit	*Yes/No	
14.	Actual date of commissioning		
15.	No. of years in successful operation prior to the date of bid opening.		
16.	<p>Following documents are enclosed in support of meeting the stipulated Qualifying Requirements for this reference plant:</p> <p>a) Relevant portion of Letter of Award/Contract Agreement/Order</p> <p>b) End user certificate / End User Communication through mail</p> <p>c) Standard Product Catalogue/Manual indicating the Product Lifecycle</p>	<p>*Yes/No</p> <p>*Yes/No</p> <p>*Yes/No</p>	

VII. In line with meeting the qualifying requirements specified in Item No. 7.1.2 of NIT, we have associated with M/s **(Name of Associate)** whose address is **(Address of Associate)** who meets the requirement of clause 7.1.1 (B) (B3) of NIT. We confirm that our associate has supplied and commissioned **Advanced Process Control software** for

Faster load Ramp-up/Ramp-down, in closed loop which have been in successful operation in at least one (1) unit of pulverized coal fired station having unit rating of 200 MW or above, for a period of not less than one (1) year prior to the date of bid opening.

OR

SH/RH Temperature Excursion Reduction, in closed loop which have been in successful operation in at least one (1) unit of pulverized coal fired station having unit rating of 200 MW or above, for a period of not less than one (1) year prior to the date of bid opening.

The details of which are given below:

S.No.	Description	Plant No. 1	Supporting Document
1.	Name of client with full Address Fax No., Telephone No. and e-mail address		
2.	Name of Power Stations (Location and Address)		
3.	a) Name of Package/Contract b) Order/LOA No. c) Date	a) b) c)	
4.	Name & Address of the Contractor on whom the order for executing the reference plant system was placed by the Owner of the reference plant		
5.	In case the Associate is not the Contractor at SI. No. 4 above, Name & Address of the Organisation which placed order for reference plant system on the Associate.		
6.	Unit Rating (MW)		
7.	Unit No./Name		
8.	Whether pulverized coal fired station.	*Yes/No	
9.	The solution is Advanced Process Control Software. i.e. Advanced Process Control (APC) shall mean the set of techniques which use a multiple input multiple output predictive model for improving the existing performance of the control loops w.r.t the desired objective (i.e. efficiency improvement or emissions reduction etc). The model can be first principles based, empirical or ANN (artificial neural network) or fuzzy logic based.	*Yes/No	
10.	The APC software offered was for: a) Faster load Ramp-up/Ramp-down which means using APC for main steam pressure control loop. b) SH/RH Temperature Excursion Reduction which means using APC for SH/RH spray control loop.	*Yes/No *Yes/No	
11.	Scope of work included in the bidder's order (a) Supplied (b) Commissioned	*Yes/No *Yes/No	
12.	a) Name of the APC Software offered for this package	a)	

	<p>b) Version of APC software offered for this package</p> <p>c) Name of APC software provided in the reference Plant</p> <p>d) Version of APC software provided in the reference Plant</p> <p>e) Whether APC software offered for this package is same as that in the reference plant, or is newer versions or upgrades of the same product, or is a product whose name has been changed after version/product upgrade.</p>	<p>b)</p> <p>c)</p> <p>d)</p> <p>e) Tick whichever is applicable <input type="checkbox"/> Yes, Is Same <input type="checkbox"/> Yes, Is newer version or upgrades of the same product <input type="checkbox"/> Yes, Is a product whose name has been changed after version/product upgrade</p>	
13.	Whether the APC software for Faster load ramp-up/ramp-down or SH/RH Temperature excursion reduction is implemented in closed loop in the reference plant	*Yes/No	
14.	Successful operation		
14a.	What was the desired benefit of End-user from the APC software		
14b.	Whether End-user achieved the desired benefit	*Yes/No	
15.	Actual date of commissioning		
16.	No. of years in successful operation prior to the date of bid opening.		
17.	<p>Following documents are enclosed in support of meeting the stipulated Qualifying Requirements for this reference plant:</p> <p>a) Relevant portion of Letter of Award/Contract Agreement/Order</p> <p>b) End user certificate / End User Communication through mail</p> <p>c) Standard Product Catalogue/Manual indicating the Product Lifecycle</p>	<p>*Yes/No</p> <p>*Yes/No</p> <p>*Yes/No</p>	

Date:

(Signature)

Place: (Printed Name)
(Designation)
(Common Seal)

Note: 1. Bidders seeking qualification as per clause 7.1.2 of NIT are required to fill-up the details under Sl. No. I ,II, III, IV, V,VI & VII (as applicable) and shall strictly follow the above format while filling this Attachment to establish their meeting the Qualification Requirement.

2. Copies of Order/Letter of Award/Client Certificate and Performance Certificate from the clients, etc. are to be enclosed clearly establishing the scope of work/ years of successful operation, etc. in support of meeting the Qualifying Requirements.

* Bidder to strike out whichever is not applicable

Note : 1. Continuation sheets of like size and format may be used as per the Bidder's requirement and shall be annexed to this Schedule.

(Suggested Format)

FORMAT FOR END-USER/CLIENT CERTIFICATE (Cl. 7.1.1 (B) (B1) of NIT)

(SEPARATE COPY OF THE FORMAT TO BE FILLED AND SIGNED BY EACH END-USER ON OFFICIAL LETTER HEAD OR THROUGH OFFICIAL E-MAIL ID)

Date:

Subject: Feedback of Combustion Optimization in pulverized coal fired station having unit rating of 200MW or above

TO WHOM SO EVER IT MAY CONCERN

We hereby certify that (Name of the Combustion Optimization Software Product) used at the installation) (Version) , supplied and commissioned by(Name and Address of the supplier) at (End-User/Client Company Name) has been in successful operation in closed loop, for a period of not less than one(1) year from the below mentioned commissioning date(s):

S. No.	Name of Pulverized Coal Fired Station and Unit No.(s)	Type of Power Plant Unit (i.e. bituminous coal/ sub-bituminous coal/ brown coal/ lignite)	Capacity of Unit (in MWs)	Date of completion of commissioning (Combustion Optimization)
1.

Combustion Optimization in the above unit(s) included optimizing the flue gas O2 trim, air registers, and feeder rate bias. The desired benefit of the Combustion Optimization software wasand the same has been achieved in the above unit(s).

Place : (Signature).....
Address : (Printed Name).....
Telephone No. : (Designation).....
E-mail ID : (Company Seal).....

(Suggested Format)

FORMAT FOR END-USER/CLIENT CERTIFICATE (Cl. 7.1.1 (B) (B2) of NIT)

(SEPARATE COPY OF THE FORMAT TO BE FILLED AND SIGNED BY EACH END-USER ON OFFICIAL LETTER HEAD OR THROUGH OFFICIAL E-MAIL ID)

Date:

Subject: Feedback of Soot Blowing optimization in pulverized coal fired station having unit rating of 200MW or above

TO WHOM SO EVER IT MAY CONCERN

We hereby certify that (Name of the Soot Blowing Optimization Software Product) used at the installation) (Version) , supplied and commissioned by(Name and Address of the supplier) at (End-User/Client Company Name) has been in successful operation in closed loop, for a period of not less than one(1) year from the below mentioned commissioning date(s):

S. No.	Name of Pulverized Coal Fired Station and Unit No.(s)	Type of Power Plant Unit (i.e. bituminous coal/ sub-bituminous coal/ brown coal/ lignite)	Capacity of Unit (in MWs)	Date of completion of commissioning (Soot Blowing optimization)
1.

The desired benefit of the Soot Blowing Optimization software wasand the same has been achieved in the above unit(s).

Place : (Signature).....
Address : (Printed Name).....
Telephone No. : (Designation).....
E-mail ID : (Company Seal).....

(Suggested Format)

FORMAT FOR END-USER/CLIENT CERTIFICATE (Cl. 7.1.1 (B) (B3) of NIT) (Page 1 out 2) *

(SEPARATE COPY OF THE FORMAT TO BE FILLED AND SIGNED BY EACH END-USER ON OFFICIAL LETTER HEAD OR THROUGH OFFICIAL E-MAIL ID)

Date:

Subject: Feedback of Faster load Ramp-up/Ramp-down in pulverized coal fired station having unit rating of 200MW or above

TO WHOM SO EVER IT MAY CONCERN

We hereby certify that (Name of the Faster load Ramp-up/Ramp-down Product/ Product Suite) used at the installation) (Version) , supplied and commissioned by(Name and Address of the supplier) at (End-User/Client Company Name) has been in successful operation in closed loop, for a period of not less than one(1) year from the below mentioned commissioning date(s):

S. No.	Name of Pulverized Coal Fired Station and Unit No.(s)	Type of Power Plant Unit (i.e. bituminous coal/ sub-bituminous coal/ brown coal/ lignite)	Capacity of Unit (in MWs)	Date of completion of commissioning (Faster load Ramp-up/Ramp-down)
1.

Faster load ramp up/ ramp down used APC for main steam pressure control loop. The desired benefit of the Faster load Ramp-up/Ramp-down software wasand the same has been achieved in the above unit (s).

Place : (Signature).....
Address : (Printed Name).....
Telephone No. : (Designation).....
E-mail ID : (Company Seal).....

* Bidder to strike out this page if not applicable

(Suggested Format)

FORMAT FOR END-USER/CLIENT CERTIFICATE (Cl. 7.1.1 (B) (B3) of NIT) (Page 2 out 2) *

(SEPARATE COPY OF THE FORMAT TO BE FILLED AND SIGNED BY EACH END-USER ON OFFICIAL LETTER HEAD OR THROUGH OFFICIAL E-MAIL ID)

Date:

Subject: Feedback of SH/RH Temperature Excursion Reduction in pulverized coal fired station having unit rating of 200MW or above

TO WHOM SO EVER IT MAY CONCERN

We hereby certify that (Name of the SH/RH Temperature Excursion Reduction Product/ Product suite) used at the installation) (Version) , supplied and commissioned by(Name and Address of the supplier) at (End-User/Client Company Name) has been in successful operation in closed loop, for a period of not less than one(1) year from the below mentioned commissioning date(s):

S. No.	Name of Pulverized Coal Fired Station and Unit No.(s)	Type of Power Plant Unit (i.e. bituminous coal/ sub-bituminous coal/ brown coal/ lignite)	Capacity of Unit (in MWs)	Date of completion of commissioning (SH/RH Temperature Excursion Reduction)
1.

SH/RH temperature excursion reduction used APC for SH/RH spray control loop. The desired benefit of the SH/RH Temperature Excursion Reduction software wasand the same has been achieved in the above unit.

Place : (Signature).....
Address : (Printed Name).....
Telephone No. : (Designation).....
E-mail ID : (Company Seal).....

* Bidder to strike out this page if not applicable

**(Qualification Data pertaining to Financial Qualification of the Bidder as per Clause No. 7.2.0
(a) of the NIT)**

To,
AGM(Corp. Matls)
NTPC Limited
EOC, PlotA-8A, Sec 24,
NOIDA - 201 301

Ref: Tender No. : dated for “.....” Package

We confirm that our average annual turnover in the preceding three (3) financial years as on the date of Techno-Commercial bid opening is not less than **INR 3.67** crore or in equivalent foreign currency. In support of above, we are enclosing **audited financial statements on Standalone** and the details are as under:

(*) For the year 2017-18, we are enclosing Financial Statements Certified by a practicing Chartered Accountant.

Sl. No	Financial Year	Amount in Bidder's Currency	Amount in INR	Exchange Rate as on seven (7) days prior to date of Techno-Commercial bid opening	Document Submitted
1.	2015 - 2016				Audited Financial Statements
2.	2016 - 2017				Audited Financial Statements
3.	2017 - 2018				Audited Financial Statements/ Financial Statements Certified by a practicing Chartered Accountant (*)
4.	Average Annual Turnover for the preceding three (3) Financial Years as on date of Techno-Commercial Bid Opening.				

(*) Strike off whichever is not applicable.

In case for Fin Year 2017-18, **audited financial statements on Standalone** or Financial Statements Certified by a practicing Chartered Accountant are not available:

Sl. No	Financial Year	Amount in INR (Million)
1.	2014 - 2015	
2.	2015 - 2016	
3.	2016 - 2017	
4.	Average Annual Turnover for the preceding three (3) Financial Years as on date of Techno-Commercial Bid Opening.	
5.	<p>Since we are not able to furnish our audited/ Certified by a practicing Chartered Accountant financial statements for Fin Year 2017-18, we are submitting the following documents for substantiation of our Qualification :</p> <p>a) Certificate from the CEO/CFO stating that Financial results of the Company are under audit as on the date of Techno-commercial bid opening and the Certificate from the practicing Chartered Accountant certifying the financial parameters is not available, is enclosed as per the format at Appendix-C to this Attachment.</p>	

Date : (Printed Name).....
Place : (Designation).....
(Common Seal).....

**(Qualification Data pertaining to Financial Qualification of the Bidder as per Clause No. 7.2.0
(b) of the NIT)**

To,
AGM(Corp. Matls)
NTPC Limited
EOC, PlotA-8A, Sec 24,
NOIDA - 201 301

Ref: Tender No. : dated for “.....” Package

We hereby confirm that net worth of our company as on the last day of the preceding financial year is not less than 100% (hundred percent) of its paid-up share capital.

The Details are as under:

Sl. No	Description	As on last day of the preceding financial year
1.	Paid-up Share Capital	
2.	Net Worth	
3.	%age of Net worth to Paid-up Share Capital	
4.	Documentary evidence like Annual reports/ Audited financial statements for the last 3 financial years* in support of above is enclosed	
5.	<p>Since we are not able to furnish our audited financial statements, on standalone entity basis, we are submitting the following documents for substantiation of our Qualification :</p> <p>(a) Copies of unaudited unconsolidated financial statements of the bidder along with copies of the audited consolidated financial statements of its Holding Company for the last 3 years enclosed.</p> <p>(b) Certificate from the CEO/CFO of the Holding company stating that the unaudited unconsolidated financial statements form part of the consolidated financial statements of the Holding Company, is enclosed as per the format at Appendix-A to this Attachment.</p>	

* In case where audited results for the last preceding financial year are not available, certification of financial results from a practicing chartered accountant shall also be considered acceptable.

For Bidders meeting requirement of clause 7.2.0 (a) and/or 7.2.0 (b) of NIT based on the strength of our *Subsidiary(ies) and/or *Holding Company and/or *Subsidiaries of the Holding companies

- (a) Since we do not satisfy the financial criteria stipulated at Clause **7.2. (a)** of NIT on our own, we meet the requirement of average annual turnover based on the strength of our Holding Company who meet the stipulated turnover requirements of NIT Item No. **7.2.0 (a)** and whose net worth as on the last day of the preceding financial year is at least equal to or more than paid up share capital of the holding company.

Sl. No.	Description	As on last day of the preceding financial year
1.	Name and Address of the Holding Company	
2.	The annual turnover of the holding company in the preceding three financial years in Indian Rupees (INR) 2015-2016 2016-2017 2017-2018	
3.	The average annual turnover of the holding company in the preceding three financial years as on the date of techno-commercial bid opening	
4.	We have enclosed Annual Reports/ Audited Financial Statements for the last 3 financial years of the Holding Company	YES <input type="checkbox"/> */NO* <input type="checkbox"/>
5.	Paid-up Share Capital of the Holding Company	
6.	Net Worth of the Holding Company	
7.	%age of Net worth to Paid-up Share Capital	
8.	A Letter of Undertaking from the holding company supported by Board Resolution, pledging unconditional and irrevocable financial support for execution of the contract by the bidder in case of award, is enclosed as per the format at Appendix-B to this Attachment. A power of attorney of the person signing on behalf of holding company is also enclosed this Attachment.	
9.	Documentary evidence like Annual Report/Audited Financial Statements together with relevant schedules for the last preceding financial year/certification of financial	

	results from a practicing Chartered Accountant etc. in respect of Holding Company in support of above is enclosed to this Attachment.	
--	---	--

(b) Since we do not satisfy the financial criteria stipulated at Clause **7.2.0 (b)** of NIT on our own, we meet the requirement of net worth based on the strength of our *Subsidiary(ies) and/or *Holding Company and/or *Subsidiaries of the Holding companies, and the Net worth of the Bidder and its *Subsidiary(ies) and/or* Holding Company and/or *Subsidiary(ies) of the Holding Company, in combined manner is not less than 100% (hundred percent)of their total paid up share capital and individually, their Net worth is not less than 75% (seventy five percent) of the respective paid up share capitals.

Sl. No.	Description	As on last day of the preceding financial year
1.	Name and Address of the Subsidiary(ies) and/or* Holding Company and/or *Subsidiary(ies) of the Holding Company	
2.	Paid-up Share Capital of the Subsidiary(ies) and/or* Holding Company and/or *Subsidiary(ies) of the Holding Company	
3.	Net Worth of the Subsidiary(ies) and/or* Holding Company and/or *Subsidiary(ies) of the Holding Company	
4.	%age of Net worth to Paid-up Share Capital	
5.	Documentary evidence like Annual Report/Audited Financial Statements together with relevant schedules for the last preceding financial year/certification of financial statements from a practicing Chartered Accountant etc. in respect of Holding Company in support of above is enclosed to this Attachment.	

We further confirm that notwithstanding anything stated above, the Employer reserves the right to verify any information/documents furnished by the Bidder and also to carry out assessment of the capabilities and capacity of the bidder / subsidiaries / group companies to perform the contract, should the circumstances warrant such assessment in the overall interest of the Employer in line with Qualifying Requirement.

Date : (Printed Name).....
Place : (Designation).....
(Common Seal).....

Note :

- (i) Net worth means the sum total of the paid up share capital and free reserves. Free reserve means all reserves credited out of the profits and share premium account but does not include reserves credited out of the revaluation of the assets, write back of depreciation provision and amalgamation. Further any debit balance of Profit and Loss account and miscellaneous expenses to the extent not adjusted or written off, if any, shall be reduced from reserves and surplus.
- (ii) Other income shall not be considered for arriving at annual turnover.
- (iii) "Holding Company" and "Subsidiary Company" shall have the meaning ascribed to them as per Companies Act of India.

**PROFORMA OF CERTIFICATE FROM THE CEO/CFO OF THE HOLDING COMPANY IN
ACCORDANCE WITH CLAUSE NO 7.2 OF NIT (To be submitted by Bidder along with the Bid)
(To be submitted in Envelope 2)**

To,
AGM(Corp. Matls)
NTPC Limited
EOC, Plot A-8A, Sec-24,
NOIDA - 201 301

Ref: Tender No. : dated for “.....” Package

Dear Sir,

- 1.0 I, Mr..... (CEO/CFO of the holding company)*, declare that M/s (Name of the Holding Company) is the Holding Company of M/s (Name of the Bidder).
- 2.0 I hereby confirm and undertake that the unaudited unconsolidated financial statements submitted in respect of the bidder as part of the bid reference no dated have been considered for the purposes of the finalization of Consolidated financial statements of the Holding Company as part of the Annual Reports.
- 3.0 I further, certify that the figures in the unaudited unconsolidated financial statements are true and correct and same have been duly reflected in the audited consolidated financial statements and/or Annual Report of the Holding Company.

Yours faithfully,

(Signature)

Date: Name & Designation.....
Place: Name of the Holding Company.....
Seal of the Holding Company.....

* Strike Off whichever is not applicable

**PROFORMA OF LETTER OF UNDERTAKING (TO BE FURNISHED ON NON-JUDICIAL STAMP PAPER OF APPROPRIATE VALUE) [To be executed by the Holding Company Supported by Board Resolution and submitted by the Bidder along with the Bid, in case financial support is being extended by the Holding Company to the by Bidder for meeting the stipulated Financial Qualifying Requirement as per Clause No. 7.2 of NIT)
(To be submitted in Envelope 2)**

To,
AGM(Corp. Matls)
NTPC Limited
EOC, Plot A_8A, Sec-24,
NOIDA - 201 301

Ref: Tender No. : dated for “.....” Package

Dear Sir,

1.0 We, M/s declare that we are the holding company of M/s (Name of the Bidder) and have controlling interest therein.

M/s (Name of the Bidder) proposes to submit the bid for the package (Name of the package) for (Name of the Project) under bid reference no dated and have sought financial strength and support from us for meeting the stipulated Financial Qualifying Requirement as per Item No. 7.2.0 NIT.

2.0 We hereby undertake that we hereby pledge our unconditional & irrevocable financial support for the execution of the said package to M/s (Name of the Bidder), for the execution of the Contract, in case they are awarded the Contract for the said package at the end of the bidding process.

We further agree that this undertaking shall be without prejudice to the various liabilities that M/s (Name of Bidder) would be required to undertake in terms of the Contract including the Performance Security as well as other obligations of the Bidder/Contractor.

3.0 This undertaking is irrevocable and unconditional, and shall remain in force till the successful execution and performance of the entire contract and/or till it is discharged by Employer.

4.0 We are herewith enclosing a copy of the Board Resolution in support of this undertaking.

Yours faithfully,

(Signature of Authorized Signatory on behalf of the Holding Company)

Date:	Name & Designation.....
Place:	Name of the Holding Company.....
	Seal of the Holding Company.....

WITNESS:

1.
2.

**Proforma of Certificate From the CEO/CFO of the Company in Accordance with
CLAUSE NO. 7.2 OF NIT
(To be submitted by Bidder alongwith the Techno-Commercial Bid)
(To be submitted in Envelope 2)**

To,
AGM(Corp. Matls)
NTPC Limited
EOC, Plot A-8A, Sec-24
NOIDA - 201 301

Ref: Tender No. : dated for “.....” Package

Dear Sir,

I, Mr. (CEO of the Company / CFO of the Company)* hereby confirm and undertake that the Financial results of the Company are under audit as on the date of Techno-commercial bid opening and the Certificate from the practicing Chartered Accountant certifying the financial parameters is not available

Yours faithfully

(Signature)

Date : (Name & Designation).....
Place : (Name of the Company).....
(Seal of Holding Company).....

Note : *Strike off whichever is not applicable.

**(Details pertaining to Financial Qualification of the Associate
as per Clause No. 7.3.0 (a) of the NIT)**

To,
AGM(Corp. Matls)
NTPC Limited
EOC, PlotA-8A, Sec 24,
NOIDA - 201 301

Ref: Tender No. : dated for “.....” Package

We confirm that our(**Associate**) average annual turnover in the preceding three (3) financial years as on the date of Techno-Commercial bid opening is not less than **INR 3.67** crore or in equivalent foreign currency. In support of above, we are enclosing **audited financial statements on Standalone** and the details are as under:

(*) For the year 2017-18, we are enclosing Financial Statements Certified by a practicing Chartered Accountant.

Sl. No	Financial Year	Amount in Bidder's Currency	Amount in INR	Exchange Rate as on seven (7) days prior to date of Techno-Commercial bid opening	Document Submitted
5.	2015 - 2016				Audited Financial Statements
6.	2016 - 2017				Audited Financial Statements
7.	2017 - 2018				Audited Financial Statements/ Financial Statements Certified by a practicing Chartered Accountant (*)
8.	Average Annual Turnover for the preceding three (3) Financial Years as on date of Techno-Commercial Bid Opening.				

(*) Strike off whichever is not applicable.

In case for Fin Year 2017-18, **audited financial statements on Standalone** or Financial Statements Certified by a practicing Chartered Accountant (for Associate's) are not available:

Sl. No	Financial Year	Amount in INR (Million)
6.	2014 - 2015	
7.	2015 - 2016	
8.	2016 - 2017	
9.	Average Annual Turnover for the preceding three (3) Financial Years as on date of Techno-Commercial Bid Opening.	
10	<p>Since we are not able to furnish our audited/ Certified by a practicing Chartered Accountant financial statements for Fin Year 2017-18 (for Associate's), we are submitting the following documents for substantiation of our Qualification:</p> <p>a) Certificate from the CEO/CFO of associate stating that Financial results of the Company are under audit as on the date of Techno-commercial bid opening and the Certificate from the practicing Chartered Accountant certifying the financial parameters is not available, is enclosed as per the format at Appendix-C to this Attachment.</p>	

Date : (Printed Name).....
Place : (Designation).....
(Common Seal).....

(Details pertaining to Financial Qualification of the Associate as per Clause No. 7.3.0 (b) of the NIT)

To,
AGM(Corp. Matls)
NTPC Limited
EOC, PlotA-8A, Sec 24,
NOIDA - 201 301

Ref: Tender No. : dated for “.....” Package

We hereby confirm that net worth of our**(Associate)** as on the last day of the preceding financial year is not less than 100% of its paid-up share capital.

The Details are as under:

Sl. No	Description	As on last day of the preceding financial year
1.	Paid-up Share Capital	
2.	Net Worth	
3.	%age of Net worth to Paid-up Share Capital	
4.	Documentary evidence like Annual reports/ Audited financial statements for the last 3 financial years* in support of above is enclosed	
5.	<p>Since we are not able to furnish our audited financial statements (of associate), on standalone entity basis, we are submitting the following documents for substantiation of our Qualification :</p> <p>(a) Copies of unaudited unconsolidated financial statements of the bidder along with copies of the audited consolidated financial statements of its Holding Company for the last 3 years enclosed.</p> <p>(b) Certificate from the CEO/CFO of the Holding company of associate stating that the unaudited unconsolidated financial statements form part of the consolidated financial statements of the Holding Company of associate, is enclosed as per the format at Appendix-A to</p>	

* In case where audited results for the last preceding financial year are not available, certification of financial results from a practicing chartered accountant shall also be considered acceptable.

For Associate/Collaborator meeting requirement of Item No. 7.3.0 (a) and/or 7.3.0 (b) of NIT based on the strength of our *Subsidiary(ies) and/or *Holding Company and/or *Subsidiaries of the Holding companies

- (a) Since our**(Associate/Collaborator)** do not satisfy the financial criteria stipulated at Clause 7.3.0 (a) of NIT on its own, they meet the requirement of average annual turnover based on the strength of their Holding Company who meet the stipulated turnover requirements of clause 7.3.0 (a) of NIT and whose networth as on the last day of the preceding financial year is at least equal to or more than paid up share capital of the holding company.

Sl. No.	Description	As on last day of the preceding financial year
1.	Name and Address of the Holding Company of associate	
2.	The annual turnover of the holding company of associate in the preceding three financial years in Indian Rupees (INR) 2015-2016 2016-2017 2017-2018	
3.	The average annual turnover of the holding company of associate in the preceding three financial years as on the date of techno-commercial bid opening	
4.	We have enclosed Annual Reports/ Audited Financial Statements for the last 3 financial years of the Holding Company of associate	YES <input type="checkbox"/> */NO* <input type="checkbox"/>
5.	Paid-up Share Capital of the Holding Company of associate	
6.	Net Worth of the Holding Company of associate	
7.	%age of Net worth to Paid-up Share Capital	
8.	A Letter of Undertaking from the holding company of associate supported by Board Resolution, pledging unconditional and irrevocable financial support for execution of the contract by the bidder in case of award, is enclosed as per the format at Appendix-B to this Attachment. A power of attorney of the person signing on behalf of holding company of associate is also enclosed this Attachment.	
9.	Documentary evidence like Annual Report/Audited Financial Statements together with relevant schedules for the last preceding financial year/certification of financial results from a practicing Chartered Accountant etc. in respect of Holding Company of associate in support of above is enclosed to this Attachment.	

- (b) Since our**(Associate/Collaborator)** do not satisfy the financial criteria stipulated at Clause 4.2.1(b) of BDS on their own, they meet the requirement of net worth based on the strength of their *Subsidiary(ies) and/or *Holding Company and/or *Subsidiaries of the Holding companies, and the Net worth of the our**(Associate/Collaborator)** and its *Subsidiary(ies) and/or* Holding Company and/or *Subsidiary(ies) of the Holding Company, in combined manner is not be less than 100% of their total paid up share capital and individually, their Net worth is not less than 75% of their respective paid up share capitals.

Sl. No.	Description	As on last day of the preceding financial year
1.	Name and Address of the Subsidiary(ies) and/or* Holding Company and/or *Subsidiary(ies) of the Holding Company of associate	
2.	Paid-up Share Capital of the Subsidiary(ies) and/or* Holding Company and/or *Subsidiary(ies) of the Holding Company of associate	
3.	Net Worth of the Subsidiary(ies) and/or* Holding Company and/or *Subsidiary(ies) of the Holding Company of associate	
4.	%age of Net worth to Paid-up Share Capital	
5.	Documentary evidence like Annual Report/Audited Financial Statements together with relevant schedules for the last preceding financial year/certification of financial statements from a practicing Chartered Accountant etc. in respect of Holding Company in support of above is enclosed to this Attachment.	

We further confirm that notwithstanding anything stated above, the Employer reserves the right to verify any information/documents furnished by the Bidder and also to carry out assessment of the capabilities and capacity of the bidder / subsidiaries / group companies to perform the contract, should the circumstances warrant such assessment in the overall interest of the Employer in line with Qualifying Requirement.

Date : (Printed Name).....
 Place : (Designation).....
 (Common Seal).....

Note :

- (i) Net worth means the sum total of the paid up share capital and free reserves. Free reserve means all reserves credited out of the profits and share premium account but does not include reserves credited out of the revaluation of the assets, write back of depreciation provision and amalgamation. Further any debit balance of Profit and Loss account and

miscellaneous expenses to the extent not adjusted or written off, if any, shall be reduced from reserves and surplus.

- (ii) Other income shall not be considered for arriving at annual turnover.
- (iii) "Holding Company" and "Subsidiary Company" shall have the meaning ascribed to them as per Companies Act of India.

**PROFORMA OF CERTIFICATE FROM THE CEO/CFO OF THE HOLDING COMPANY OF ASSOCIATE
IN ACCORDANCE WITH CLAUSE NO 7.3.0 OF NIT (To be submitted by Bidder along with the Bid)
(To be submitted in Envelope 2)**

To,
AGM(Corp. Matls)
NTPC Limited
EOC, Plot A-8A, Sec-24,
NOIDA - 201 301

Ref: Tender No. : dated for “.....” Package

Dear Sir,

- 1.0 I, Mr..... (CEO/CFO of the holding company of associate)*, declare that M/s (Name of the Holding Company of associate) is the Holding Company of M/s (Name of the associate).
- 2.0 I hereby confirm and undertake that the unaudited unconsolidated financial statements submitted in respect of the associate as part of the bid reference no dated have been considered for the purposes of the finalization of Consolidated financial statements of the Holding Company of associate as part of the Annual Reports.
- 4.0 I further, certify that the figures in the unaudited unconsolidated financial statements are true and correct and same have been duly reflected in the audited consolidated financial statements and/or Annual Report of the Holding Company of associate.

Yours faithfully,

(Signature)

Date:	Name & Designation.....
Place:	Name of the Holding Company of associate
	Seal of the Holding Company of associate

* Strike Off whichever is not applicable

**PROFORMA OF LETTER OF UNDERTAKING (TO BE FURNISHED ON NON-JUDICIAL STAMP PAPER OF APPROPRIATE VALUE) [To be executed by the Holding Company of associate Supported by Board Resolution and submitted by the Bidder along with the Bid, in case financial support is being extended by the Holding Company of associate to the by Bidder for meeting the stipulated Financial Qualifying Requirement as per Clause No. 7.3.0 of NIT)
(To be submitted in Envelope 2)**

To,
AGM(Corp. Matls)
NTPC Limited
EOC, Plot A_8A, Sec-24,
NOIDA - 201 301

Ref: Tender No. : dated for “.....” Package

Dear Sir,

1.0 We, M/s (Name of the Holding Company of associate) declare that we are the holding company of M/s (Name of the associate) and have controlling interest therein.

M/s (Name of the associate) proposes to submit the bid for the package (Name of the package) under bid reference no dated and have sought financial strength and support from us for meeting the stipulated Financial Qualifying Requirement as per Item No. 7.3.0 NIT.

2.0 We hereby undertake that we hereby pledge our unconditional & irrevocable financial support for the execution of the said package to M/s (Name of the associate), for the execution of the Contract, in case they are awarded the Contract for the said package at the end of the bidding process.

We further agree that this undertaking shall be without prejudice to the various liabilities that M/s (Name of associate) would be required to undertake in terms of the Contract including the Performance Security as well as other obligations of the associate.

3.0 This undertaking is irrevocable and unconditional, and shall remain in force till the successful execution and performance of the entire contract and/or till it is discharged by Employer.

4.0 We are herewith enclosing a copy of the Board Resolution in support of this undertaking.

Yours faithfully,

(Signature of Authorized Signatory on behalf of the Holding Company)

Date:	Name & Designation.....
Place:	Name of the Holding Company
	of associate
	Seal of the Holding Company
	of associate

WITNESS:

1.
2.

**Proforma of Certificate From the CEO/CFO of the Company of associate in
Accordance with CLAUSE NO. 7.3.0 OF NIT
(To be submitted by Bidder alongwith the Techno-Commercial Bid)
(To be submitted in Envelope 2)**

To,
AGM(Corp. Matls)
NTPC Limited
EOC, Plot A-8A, Sec-24
NOIDA - 201 301

Ref: Tender No. : dated for “.....” Package

Dear Sir,

I, Mr. (CEO of the Company / CFO of the Company of associate)* hereby confirm and undertake that the Financial results of the Company are under audit as on the date of Techno-commercial bid opening and the Certificate from the practicing Chartered Accountant certifying the financial parameters is not available

Yours faithfully

(Signature)

Date : (Name & Designation).....
Place : (Name of the associate Company).....
(Seal of Holding Company).....

Note : *Strike off whichever is not applicable.

**Advanced Process Control-(APC) PACKAGE
FOR
SIMHADRI Stg-I (2 X 500 MW) & Stg-II(2X500 MW)
NIT NO. 40086783**

**FORM OF DEED OF JOINT UNDERTAKING
(ON NON-JUDICIAL STAMP PAPER OF APPROPRIATE VALUE)**

**DEED OF JOINT UNDERTAKING TO BE EXECUTED BY THE ASSOCIATE ALONG WITH BIDDER AS PER CLAUSE
7.1.2 OF NIT**

**(APPLICABLE FOR THE BIDDER WHO MEETS THE REQUIREMENTS OF CLAUSE NO. 7.1.1 (A) OF NIT AND
ASSOCIATES WITH APC SUPPLIER WHO MEETS THE REQUIREMENTS OF CLAUSE NO 7.1.1 (B) (B1) OF NIT)**

This DEED of UNDERTAKING executed this day of Two thousand
by M/s,
a Company incorporated under the laws of having its Registered Office at
..... (hereinafter called the
"Associate", which expression shall include its successors, administrators, executors and permitted assigns)
and M/s, a company registered under the laws of
..... having its registered office at
..... (hereinafter called the "Bidder/Contractor",
which expression shall include its successors, administrators, executors and permitted assigns) in favour of
M/s NTPC Limited, A Government of India Enterprise, incorporated under the Companies Act, 1956, having
its Registered Office at NTPC Bhawan, Scope Complex, 7, Institutional Area, Lodhi Road, New Delhi-110003,
INDIA (hereinafter called "NTPC" or "Employer" which expression shall include its successors,
administrators, executors and assigns).

WHEREAS, the Employer invited Bids for Advanced Process Control-(APC) Package for SIMHADRI Stg-I (2 X
500 MW) & Stg-II(2X500 MW) for design, testing, supply, installation, commissioning of APC (Advanced
Process Control) software as per the scope vide NIT No. 40086783.

AND WHEREAS Clause No. 7.1.2 of NIT stipulates that the Bidder can also participate provided the Bidder
meets the requirements stipulated at Clause No. 7.1.1 (A) of NIT and the bidder associates with APC
Supplier, who meets the stipulated requirements at Clause No. 7.1.1 (B) (B1) of NIT and submits a Deed of
Joint undertaking jointly executed by the Bidder and its Associate in which the bidder and its Associate are
jointly and severally liable to the Employer for successful performance of the Combustion Optimization
Portion of the Contract specified in the NIT No. 40086783.

WHEREAS M/s (Bidder/Contractor) is submitting its proposal ref. no.
..... dated (hereinafter called the "Bid"), in response to the aforesaid Invitation for Bid by
the Employer against NIT No. 40086783.

AND WHEREAS M/s (Bidder/Contractor) meets the
requirements of Clause No 7.1.1. (A) of NIT and associates with M/s (Associate) who
meets the requirement of Clause No. 7.1.1 (B) (B1) of NIT.

And Where as a pre-condition for submitting the bid, the Bidder and the Associate are required to jointly execute and furnish alongwith the Techno-Commercial bid an irrevocable Deed of Joint Undertaking and be jointly and severally responsible and bound unto the Employer for the successful performance of the APC Software for Combustion Optimization portion to be supplied under Advanced Process Control-(APC) Package for SIMHADRI Stg-I (2 X 500 MW) & Stg-II(2X500 MW) and fully meeting the stipulated technical requirements, guaranteed parameters and characteristics as per bidding documents, in the event the Bid is accepted by the Employer resulting in a Contract (hereinafter called the "Contract").

NOW THEREFORE, THIS UNDERTAKING WITNESSETH AS UNDER:

1. That in consideration of the Award of the Contract by the Employer to the Contractor, we, the aforesaid Associate and the Contractor, do hereby declare and undertake that we shall be jointly and severally responsible to the Employer to perform all the Contractual obligations under the contract including the meeting minimum improvement figure, successful execution and performance of the APC Software for Combustion Optimization portion, as specified under the said contract.
2. In case of any breach of the Contract committed by the Contractor, we, the Associate, do hereby undertake, declare and confirm that we shall be fully responsible for successful performance of the APC Software for Combustion Optimization portion under the Contract and undertake to carry out all obligations and responsibilities under this Deed of Joint Undertaking. Further if the Employer sustains any loss or damage on account of any breach of the Contract on account of APC Software for Combustion Optimization portion, we, the Associate and the Contractor jointly and severally undertake to promptly indemnify, and pay such losses/damages caused to the Employer on its written demand without any demur, reservation, contest or protest in any manner whatsoever. This is without prejudice to any rights of the Employer against the Contractor under the Contract and/or guarantees. It shall not be necessary or obligatory for the Employer to first proceed against the Contractor before proceeding against the Associate/Collaborator (with respect to obligations and responsibilities of the Associate/Collaborator covered under this Deed of Joint Undertaking), nor any extension of time or any relaxation given by the Employer to the Contractor shall prejudice any rights of the Employer under this Deed of Joint Undertaking to proceed against the Associate.
3. Without prejudice to the generality of the undertaking in paragraph 1 above, the manner of achieving the objectives set forth in paragraph 1 above shall be as follows:
 - a. The Associate shall be fully responsible for design, testing, supply, installation, commissioning and carrying out performance testing of the APC Software for Combustion Optimization portion to the satisfaction of the Employer. Further, the Associate shall depute their technical experts from time to time to the Contractor's works/Employer's Project Site as required by Employer and agreed to by the Contractor/Associate to facilitate the successful performance of the APC Software for Combustion Optimization portion stipulated in the aforesaid Contract. Further the Associate shall ensure proper design, testing, supply, installation, commissioning & successful performance of the APC Software for Combustion Optimization portion covered under the said contract in accordance with the stipulations of the Bidding Documents and if necessary the Associate shall advise the Contractor suitable modifications of design and implement necessary corrective measures to discharge the obligations under the Contract.
 - b. In the event the Associate and Contractor fail to demonstrate successful performance of the APC Software for Combustion Optimization portion as set forth in paragraph 1 above, the Associate and

the Contractor shall promptly carry out all the corrective measures at their own expense and shall promptly provide corrected designs to the Employer.

- c. Implementation of the corrected designs and all other necessary repairs, replacements, rectifications or modifications to the APC Software for Combustion Optimization portion and payments of financial liabilities, penalties and any other obligations as provided under the Contract shall be the joint and several responsibilities of the Contractor and Associate.
4. We, the Contractor and Associate do hereby undertake and confirm that this Undertaking shall be irrevocable and shall not be revoked till ninety (90) days after the expiry of warranty period of the Advanced Process Control-(APC) Package for SIMHADRI Stg-I (2 X 500 MW) & Stg-II(2X500 MW) under the Contract and further stipulate that the Undertaking herein contained shall terminate after ninety (90) days of satisfactory completion of such warranty period. We further agree that this undertaking shall be without any prejudice to the various liabilities of the Contractor, including the Contract Performance Security as well as other obligations of the Contractor in terms of the Contract.
5. The Contractor and Associate will be fully responsible for the quality of the APC Software for Combustion Optimization portion , and their repair or replacement, if necessary, and timely execution thereof to meet the completion schedule under the Contract.
6. In case of award, in addition to the Contractor Performance Bank Guarantee furnished by the Contractor, the Associate shall furnish "as Security" an on demand Performance Bank Guarantee, from Bank specified in the bidding documents in favour of the Employer in a form acceptable to Employer as per provisions of the bidding documents. The value of such Bank Guarantee shall be equal to Five Percent (5%) of the total Contract Price of Advanced Process Control-(APC) Package for SIMHADRI Stg-I (2 X 500 MW) & Stg-II(2X500 MW) as awarded by the Employer to the Contractor and it shall be guarantee towards the faithful performance/compliance of this Deed of Joint Undertaking in accordance with the terms and conditions specified herein. The Bank Guarantee shall be unconditional, irrevocable and valid till ninety (90) days beyond the end of warranty period of the Advanced Process Control-(APC) Package for SIMHADRI Stg-I (2 X 500 MW) & Stg-II(2X500 MW) covered under the contract. In case of delay in completion of warranty period, the validity of this Bank Guarantee shall be extended by the period of such delay. The Bank Guarantee amount shall be promptly paid to the Employer on demand without any demur, reservation, protest or contest.
7. Any dispute that may arise in connection with this Deed of Joint Undertaking shall be settled as per arbitration procedure / rules mentioned in the Bidding Documents. This Deed of Joint Undertaking shall be construed and interpreted in accordance with the Laws of India and the Courts of Delhi shall have exclusive jurisdiction.
8. We, the Associate and the Contractor agree that this Undertaking shall be irrevocable and shall form an integral part of the Contract. We further agree that this Undertaking shall continue to be enforceable till its validity.
9. That this Deed shall be operative from the effective date of the NOA.

IN WITNESS WHEREOF, the Associate and the Contractor, through their authorized representatives, have executed these presents and affixed common seals of their respective companies on the Day, Month and Year first mentioned above.

WITNESS:

1.
(Signature of the Authorised Representative)

For M/s
(Associate)

(Signature, Name & Address)

.....
Name
Designation.....

(Common Seal of the Company)

.....

WITNESS:

1.
(Signature of the Authorised Representative)

For M/s
(Bidder/Contractor)

(Signature, Name & Address)

.....
Name
Designation.....

(Common Seal of the Company)

.....

Note:

1. Power of Attorney of the persons signing on behalf of Associate and Bidder / Contractor is to be furnished by the bidder and to be enclosed with the signed Deed of Joint Undertaking.
2. The Bank Guarantee shall be from a Bank as per provisions of ATTACHMENT 2 Volume-I SECTION – IV Forms /Bid Data Sheet.

**Advanced Process Control-(APC) PACKAGE
FOR
SIMHADRI Stg-I (2 X 500 MW) & Stg-II(2X500 MW)
NIT NO. 40086783**

**FORM OF DEED OF JOINT UNDERTAKING
(ON NON-JUDICIAL STAMP PAPER OF APPROPRIATE VALUE)**

**DEED OF JOINT UNDERTAKING TO BE EXECUTED BY THE ASSOCIATE ALONG WITH BIDDER AS PER CLAUSE
7.1.2 OF NIT**

**(APPLICABLE FOR THE BIDDER WHO MEETS THE REQUIREMENTS OF CLAUSE NO. 7.1.1 (A) OF NIT AND
ASSOCIATES WITH APC SUPPLIER WHO MEETS THE REQUIREMENTS OF CLAUSE NO 7.1.1 (B) (B2) OF NIT)**

This DEED of UNDERTAKING executed this day of Two thousand
by M/s,
a Company incorporated under the laws of having its Registered Office at
..... (hereinafter called the
"Associate", which expression shall include its successors, administrators, executors and permitted assigns)
and M/s, a company registered under the laws of
..... having its registered office at
..... (hereinafter called the "Bidder/Contractor",
which expression shall include its successors, administrators, executors and permitted assigns) in favour of
M/s NTPC Limited, A Government of India Enterprise, incorporated under the Companies Act, 1956, having
its Registered Office at NTPC Bhawan, Scope Complex, 7, Institutional Area, Lodhi Road, New Delhi-110003,
INDIA (hereinafter called "NTPC" or "Employer" which expression shall include its successors,
administrators, executors and assigns).

WHEREAS, the Employer invited Bids for Advanced Process Control-(APC) Package for SIMHADRI Stg-I (2 X
500 MW) & Stg-II(2X500 MW) for design, testing, supply, installation, commissioning of APC (Advanced
Process Control) software as per the scope vide NIT No. 40086783.

AND WHEREAS Clause No. 7.1.2 of NIT stipulates that the Bidder can also participate provided the Bidder
meets the requirements stipulated at Clause No. 7.1.1 (A) of NIT and the bidder associates with APC
Supplier, who meets the stipulated requirements at Clause No. 7.1.1 (B) (B2) of NIT and submits a Deed of
Joint undertaking jointly executed by the Bidder and its Associate in which the bidder and its Associate are
jointly and severally liable to the Employer for successful performance of the Soot Blowing Optimization
Portion of the Contract specified in the NIT No. 40086783.

WHEREAS M/s (Bidder/Contractor) is submitting its proposal ref. no.
..... dated (hereinafter called the "Bid"), in response to the aforesaid Invitation for Bid by
the Employer against NIT No. 40086783.

AND WHEREAS M/s (Bidder/Contractor) meets the
requirements of Clause No. 7.1.1 (A) of NIT and associates with M/s (Associate) who
meets the requirement of Clause No. 7.1.1 (B) (B2) of NIT.

And Where as a pre-condition for submitting the bid, the Bidder and the Associate are required to jointly
execute and furnish alongwith the Techno-Commercial bid an irrevocable Deed of Joint Undertaking and be

jointly and severally responsible and bound unto the Employer for the successful performance of the APC Software for Soot Blowing Optimization portion to be supplied under Advanced Process Control-(APC) Package for SIMHADRI Stg-I (2 X 500 MW) & Stg-II(2X500 MW) and fully meeting the stipulated technical requirements, guaranteed parameters and characteristics as per bidding documents, in the event the Bid is accepted by the Employer resulting in a Contract (hereinafter called the "Contract").

NOW THEREFORE, THIS UNDERTAKING WITNESSETH AS UNDER:

1. That in consideration of the Award of the Contract by the Employer to the Contractor, we, the aforesaid Associate and the Contractor, do hereby declare and undertake that we shall be jointly and severally responsible to the Employer to perform all the Contractual obligations under the contract including the Minimum Improvement Figure, successful execution and performance of the Soot Blowing Optimization portion of APC Software, as specified under the said contract.
2. In case of any breach of the Contract committed by the Contractor, we, the Associate, do hereby undertake, declare and confirm that we shall be fully responsible for performance of the APC Software for Soot Blowing Optimization portion under the Contract and undertake to carry out all obligations and responsibilities under this Deed of Joint Undertaking. Further if the Employer sustains any loss or damage on account of any breach of the Contract, we, the Associate and the Contractor jointly and severally undertake to promptly indemnify, and pay such losses/damages caused to the Employer on its written demand without any demur, reservation, contest or protest in any manner whatsoever. This is without prejudice to any rights of the Employer against the Contractor under the Contract and/or guarantees. It shall not be necessary or obligatory for the Employer to first proceed against the Contractor before proceeding against the Associate/Collaborator (with respect to obligations and responsibilities of the Associate/Collaborator covered under this Deed of Joint Undertaking), nor any extension of time or any relaxation given by the Employer to the Contractor shall prejudice any rights of the Employer under this Deed of Joint Undertaking to proceed against the Associate.
3. Without prejudice to the generality of the undertaking in paragraph 1 above, the manner of achieving the objectives set forth in paragraph 1 above shall be as follows:
 - a. The Associate shall ~~will~~ be fully responsible for design, testing, supply, installation, commissioning and carrying out performance testing of the APC Software for Soot Blowing Optimization portion to the satisfaction of the Employer. Further, the Associate shall depute their technical experts from time to time to the Contractor's works/Employer's Project Site as required by Employer and agreed to by the Contractor/Associate to facilitate the successful performance of the APC Software for Soot Blowing Optimization portion stipulated in the aforesaid Contract.
Further the Associate shall ensure proper design, testing, supply, installation, commissioning & successful performance of the APC Software for Soot Blowing Optimization portion covered under the said contract in accordance with the stipulations of the Bidding Documents and if necessary the Associate shall advise the Contractor suitable modifications of design and implement necessary corrective measures to discharge the obligations under the Contract.
 - b. In the event the Associate and Contractor fail to demonstrate successful performance of the APC Software for Soot Blowing Optimization portion as set forth in paragraph 1 above, the Associate and the Contractor shall promptly carry out all the corrective measures at their own expense and shall promptly provide corrected designs to the Employer.
 - c. Implementation of the corrected designs and all other necessary repairs, replacements, rectifications or modifications to the APC Software for Soot Blowing Optimization portion and

payments of financial liabilities, penalties and any other obligations as provided under the Contract shall be the joint and several responsibilities of the Contractor and Associate.

4. We, the Contractor and Associate do hereby undertake and confirm that this Undertaking shall be irrevocable and shall not be revoked till ninety (90) days after the expiry of warranty period of the Advanced Process Control-(APC) Package for SIMHADRI Stg-I (2 X 500 MW) & Stg-II(2X500 MW) under the Contract and further stipulate that the Undertaking herein contained shall terminate after ninety (90) days of satisfactory completion of such warranty period. We further agree that this undertaking shall be without any prejudice to the various liabilities of the Contractor, including the Contract Performance Security as well as other obligations of the Contractor in terms of the Contract.
5. The Contractor and Associate will be fully responsible for the quality of the APC Software for Soot Blowing Optimization portion, and their repair or replacement, if necessary, and timely execution thereof to meet the completion schedule under the Contract.
6. In case of award, in addition to the Contractor Performance Bank Guarantee furnished by the Contractor, the Associate shall furnish "as Security" an on demand Performance Bank Guarantee, from Bank specified in the bidding documents in favour of the Employer in a form acceptable to Employer as per provisions of the bidding documents. The value of such Bank Guarantee shall be equal to Five Percent (5%) of the total Contract Price of Advanced Process Control-(APC) Package for SIMHADRI Stg-I (2 X 500 MW) & Stg-II(2X500 MW) as awarded by the Employer to the Contractor and it shall be towards guaranteeing the faithful performance/compliance of this Deed of Joint Undertaking in accordance with the terms and conditions specified herein. The Bank Guarantee shall be unconditional, irrevocable and valid till ninety (90) days beyond the end of warranty period of the Advanced Process Control-(APC) Package for SIMHADRI Stg-I (2 X 500 MW) & Stg-II(2X500 MW) covered under the contract. In case of delay in completion of warranty period, the validity of this Bank Guarantee shall be extended by the period of such delay. The Bank Guarantee amount shall be promptly paid to the Employer on demand without any demur, reservation, protest or contest.
7. Any dispute that may arise in connection with this Deed of Joint Undertaking shall be settled as per arbitration procedure / rules mentioned in the Bidding Documents. This Deed of Joint Undertaking shall be construed and interpreted in accordance with the Laws of India and the Courts of Delhi shall have exclusive jurisdiction.
8. We, the Associate and the Contractor agree that this Undertaking shall be irrevocable and shall form an integral part of the Contract. We further agree that this Undertaking shall continue to be enforceable till its validity.
9. That this Deed shall be operative from the effective date of the NOA.

IN WITNESS WHEREOF, the Associate and the Contractor, through their authorized representatives, have executed these presents and affixed common seals of their respective companies on the Day, Month and Year first mentioned above.

WITNESS:

1.
(Signature of the Authorised Representative)

For M/s
(Associate)

(Signature, Name & Address)

.....
Name
Designation.....

(Common Seal of the Company)

.....

WITNESS:

1.
(Signature of the Authorised Representative)

For M/s
(Bidder/Contractor)

(Signature, Name & Address)

.....
Name
Designation.....

(Common Seal of the Company)

.....

Note:

1. Power of Attorney of the persons signing on behalf of Associate and Bidder / Contractor is to be furnished by the bidder and to be enclosed with the signed Deed of Joint Undertaking.
2. The Bank Guarantee shall be from a Bank as per provisions of ATTACHMENT 2 Volume-I SECTION – IV Forms /Bid Data Sheet.

**Advanced Process Control-(APC) PACKAGE
FOR
SIMHADRI Stg-I (2 X 500 MW) & Stg-II(2X500 MW)
NIT NO. 40086783**

**FORM OF DEED OF JOINT UNDERTAKING
(ON NON-JUDICIAL STAMP PAPER OF APPROPRIATE VALUE)**

**DEED OF JOINT UNDERTAKING TO BE EXECUTED BY THE ASSOCIATE ALONG WITH BIDDER AS PER
CLAUSE 7.1.2 OF NIT**

**(APPLICABLE FOR THE BIDDER WHO MEETS THE REQUIREMENTS OF CLAUSE NO. 7.1.1 (A) OF NIT AND
ASSOCIATES WITH APC SUPPLIER WHO MEETS THE REQUIREMENTS OF CLAUSE NO. 7.1.1 (B) (B3) OF
NIT)**

This DEED of UNDERTAKING executed this day of Two thousand by M/s, a Company incorporated under the laws of having its Registered Office at (hereinafter called the "Associate", which expression shall include its successors, administrators, executors and permitted assigns) and M/s, a company registered under the laws of having its registered office at (hereinafter called the "Bidder/Contractor", which expression shall include its successors, administrators, executors and permitted assigns) in favour of M/s NTPC Limited, A Government of India Enterprise, incorporated under the Companies Act, 1956, having its Registered Office at NTPC Bhawan, Scope Complex, 7, Institutional Area, Lodhi Road, New Delhi-110003, INDIA (hereinafter called "NTPC" or "Employer" which expression shall include its successors, administrators, executors and assigns).

WHEREAS, the Employer invited Bids for Advanced Process Control-(APC) Package for SIMHADRI Stg-I (2 X 500 MW) & Stg-II(2X500 MW) for design, testing, supply, installation, commissioning of APC (Advanced Process Control) software as per the scope vide NIT No. 40086783.

AND WHEREAS Clause No. 7.1.2 of NIT stipulates that the Bidder can also participate provided the Bidder meets the requirements stipulated at Clause No. 7.1.1 (A) of NIT and the bidder associates with APC Supplier, who meets the stipulated requirements at Clause No. 7.1.1 (B) (B3) of NIT and submits a Deed of Joint undertaking jointly executed by the Bidder and its Associate in which the bidder and its Associate are jointly and severally liable to the Employer for successful performance of the Faster load rampup/ramp down# SH/RH temperature excursion reduction# Portion of the Contract specified in the NIT No. 40086783.

WHEREAS M/s (Bidder/Contractor) is submitting its proposal ref. no. dated (hereinafter called the "Bid"), in response to the aforesaid Invitation for Bid by the Employer against NIT No. 40086783.

AND WHEREAS M/s (Bidder/Contractor) meets the requirements of Clause No. 7.1.1 (A) of NIT and associates with M/s (Associate) who meets the requirement of Clause No. 7.1.1 (B) (B3) of NIT.

And Where as a pre-condition for submitting the bid, the Bidder and the Associate are required to jointly execute and furnish alongwith the Techno-Commercial bid an irrevocable Deed of Joint Undertaking and be jointly and severally responsible and bound unto the Employer for the successful performance of the APC Software for Faster load rampup/ramp down# SH/RH temperature excursion reduction# portion to be supplied under Advanced Process Control-(APC) Package for SIMHADRI Stg-I (2 X 500 MW) & Stg-II(2X500 MW) fully meeting the stipulated technical requirements, guaranteed parameters and characteristics as per bidding documents, in the event the Bid is accepted by the Employer resulting in a Contract (hereinafter called the "Contract").

NOW THEREFORE, THIS UNDERTAKING WITNESSETH AS UNDER:

1. That in consideration of the Award of the Contract by the Employer to the Contractor, we, the aforesaid Associate and the Contractor, do hereby declare and undertake that we shall be jointly and severally responsible to the Employer to perform all the Contractual obligations under the contract including the Minimum Improvement Figure, successful execution and performance of the APC Software for Faster load rampup/ramp down# SH/RH temperature excursion reduction# portion, as specified under the said contract.
2. In case of any breach of the Contract committed by the Contractor, we, the Associate, do hereby undertake, declare and confirm that we shall be fully responsible for performance of the APC Software for Faster load rampup/ramp down# SH/RH temperature excursion reduction# portion under the Contract and undertake to carry out all obligations and responsibilities under this Deed of Joint Undertaking. Further if the Employer sustains any loss or damage on account of any breach of the Contract, we, the Associate and the Contractor jointly and severally undertake to promptly indemnify, and pay such losses/damages caused to the Employer on its written demand without any demur, reservation, contest or protest in any manner whatsoever. This is without prejudice to any rights of the Employer against the Contractor under the Contract and/or guarantees. It shall not be necessary or obligatory for the Employer to first proceed against the Contractor before proceeding against the Associate/Collaborator (with respect to obligations and responsibilities of the Associate/Collaborator covered under this Deed of Joint Undertaking), nor any extension of time or any relaxation given by the Employer to the Contractor shall prejudice any rights of the Employer under this Deed of Joint Undertaking to proceed against the Associate.
3. Without prejudice to the generality of the undertaking in paragraph 1 above, the manner of achieving the objectives set forth in paragraph 1 above shall be as follows:
 - a. The Associate shall be fully responsible for design, testing, supply, installation, commissioning and carrying out performance testing of the APC Software for Faster load rampup/ramp down# SH/RH temperature excursion reduction# portion to the satisfaction of the Employer. Further, the Associate shall depute their technical experts from time to time to the Contractor's works/Employer's Project Site as required by Employer and agreed to by the Contractor/Associate to facilitate the successful performance of the APC Software for Faster load rampup/ramp down# SH/RH temperature excursion reduction# portion stipulated in the aforesaid Contract.

Further the Associate shall ensure proper design, testing, supply, installation, commissioning & the successful performance of the APC Software for Faster load rampup/ramp down# SH/RH temperature excursion reduction# portion covered under the said contract in accordance with the stipulations of the Bidding Documents and if necessary the Associate shall advise the Contractor

suitable modifications of design and implement necessary corrective measures to discharge the obligations under the Contract.

- b. In the event the Associate and Contractor fail to demonstrate successful performance of the APC Software for Faster load rampup/ramp down[#] SH/RH temperature excursion reduction[#] portion as set forth in paragraph 1 above, the Associate and the Contractor shall promptly carry out all the corrective measures at their own expense and shall promptly provide corrected designs to the Employer.
 - c. Implementation of the corrected designs and all other necessary repairs, replacements, rectifications or modifications to the APC Software for Faster load rampup/ramp down[#] SH/RH temperature excursion reduction[#] portion and payments of financial liabilities, penalties and any other obligations as provided under the Contract shall be the joint and several responsibilities of the Contractor and Associate.
4. We, the Contractor and Associate do hereby undertake and confirm that this Undertaking shall be irrevocable and shall not be revoked till ninety (90) days after the expiry of warranty period of the Advanced Process Control-(APC) Package for SIMHADRI Stg-I (2 X 500 MW) & Stg-II(2X500 MW) under the Contract and further stipulate that the Undertaking herein contained shall terminate after ninety (90) days of satisfactory completion of such warranty period. We further agree that this undertaking shall be without any prejudice to the various liabilities of the Contractor, including the Contract Performance Security as well as other obligations of the Contractor in terms of the Contract.
 5. The Contractor and Associate will be fully responsible for the quality of the Combustion Optimization portion of APC Software, and their repair or replacement, if necessary, and timely execution thereof to meet the completion schedule under the Contract.
 6. In case of award, in addition to the Contractor Performance Bank Guarantee furnished by the Contractor, the Associate shall furnish "as Security" an on demand Performance Bank Guarantee, from Bank specified in the bidding documents in favour of the Employer in a form acceptable to Employer as per provisions of the bidding documents. The value of such Bank Guarantee shall be equal to Five Percent (5%) of the total Contract Price of Advanced Process Control-(APC) Package for SIMHADRI Stg-I (2 X 500 MW) & Stg-II(2X500 MW) as awarded by the Employer to the Contractor and it shall be towards guaranteeing the faithful performance/compliance of this Deed of Joint Undertaking in accordance with the terms and conditions specified herein. The Bank Guarantee shall be unconditional, irrevocable and valid till ninety (90) days beyond the end of warranty period of the Advanced Process Control-(APC) Package for SIMHADRI Stg-I (2 X 500 MW) & Stg-II(2X500 MW) covered under the contract. In case of delay in completion of warranty period, the validity of this Bank Guarantee shall be extended by the period of such delay. The Bank Guarantee amount shall be promptly paid to the Employer on demand without any demur, reservation, protest or contest.
 7. Any dispute that may arise in connection with this Deed of Joint Undertaking shall be settled as per arbitration procedure / rules mentioned in the Bidding Documents. This Deed of Joint Undertaking shall be construed and interpreted in accordance with the Laws of India and the Courts of Delhi shall have exclusive jurisdiction.

8. We, the Associate and the Contractor agree that this Undertaking shall be irrevocable and shall form an integral part of the Contract. We further agree that this Undertaking shall continue to be enforceable till its validity.

9. That this Deed shall be operative from the effective date of the NOA.

IN WITNESS WHEREOF, the Associate and the Contractor, through their authorized representatives, have executed these presents and affixed common seals of their respective companies on the Day, Month and Year first mentioned above.

WITNESS:

1.
(Signature of the Authorized Representative)

For M/s
(Associate)

(Signature, Name & Address)

.....
Name
Designation.....

(Common Seal of the Company)

.....

WITNESS:

1.
(Signature of the Authorized Representative)

For M/s
(Bidder/Contractor)

(Signature, Name & Address)

.....
Name
Designation.....

(Common Seal of the Company)

.....

Note:

- 1. Power of Attorney of the persons signing on behalf of Associate and Bidder / Contractor is to be furnished by the bidder and to be enclosed with the signed Deed of Joint Undertaking.
- 2. The Bank Guarantee shall be from a Bank as per provisions of ATTACHMENT 2 Volume-I SECTION – IV Forms /Bid Data Sheet.

strike out whichever is not applicable

**Advanced Process Control-(APC) PACKAGE
FOR
SIMHADRI Stg-I (2 X 500 MW) & Stg-II(2X500 MW)
NIT NO. 40086783**

FORM OF NON-DISCLOSURE UNDERTAKING (THE "UNDERTAKING")

(ON NON-JUDICIAL STAMP PAPER OF APPROPRIATE VALUE)

**NON-DISCLOSURE UNDERTAKING (THE "UNDERTAKING")
TO BE EXECUTED BY THE BIDDER AS PER CLAUSE 63.0 OF SPC**

This Non-Disclosure Undertaking (the "Undertaking") is furnished by (Name of the Bidder) with its principal offices at , ("Receiving Party") in respect of Notice for Tender (NIT) issued by NTPC Ltd. with its Office at ("Disclosing Party") for the purpose of preventing the unauthorized disclosure of Confidential Information as defined below.

I/We, the Receiving Party hereby undertake to be obliged by the confidential relationship with respect to the disclosure of certain proprietary and confidential information ("Confidential Information") pertaining to the Disclosing Party.

I/We hereby declare as follows:

1. Definition of Confidential Information. For purposes of this Undertaking , "Confidential Information" shall include all information or material that has or could have commercial value or other utility in the business in which Disclosing Party is engaged. If Confidential Information is in written form, the Disclosing Party shall label or stamp the materials with the word "Confidential" or some similar warning. If Confidential Information is transmitted orally, the Disclosing Party shall promptly provide a writing indicating that such oral communication constituted Confidential Information.

2. Exclusions from Confidential Information. Receiving Party's obligations under this Undertaking do not extend to information that is: (a) publicly known at the time of disclosure or subsequently becomes publicly known through no fault of the Receiving Party; (b) discovered or created by the Receiving Party before disclosure by Disclosing Party; (c) learned by the Receiving Party through legitimate means other than from the Disclosing Party or Disclosing Party's representatives; or (d) is disclosed by Receiving Party with Disclosing Party's prior written approval.

3. Obligations of Receiving Party. Receiving Party shall hold and maintain the Confidential Information in strictest confidence and utilize for the sole and exclusive benefit of the Disclosing Party. Receiving Party shall carefully restrict access to Confidential Information to employees, contractors and third parties as is reasonably required and shall require those persons to sign nondisclosure restrictions at least as protective as those in this Undertaking. Receiving Party shall not, without prior written approval of Disclosing Party, use for Receiving Party's own benefit, publish, copy, modify, misuse, or otherwise disclose to others, or permit the use by others for their benefit or to the detriment of Disclosing Party, any Confidential Information. Receiving Party shall return to Disclosing Party any and all records, notes, and other written, printed, or tangible materials in its possession pertaining to Confidential Information immediately if Disclosing Party requests it in writing.

4. Time Periods. It is Receiving Party's duty to hold Confidential Information in confidence which shall remain in effect until the Confidential Information no longer qualifies as a trade secret or until Disclosing Party sends Receiving Party written notice releasing Receiving Party from this Undertaking, whichever occurs first.

I/We hereby undertake and confirm that, this Undertaking and the obligations herein, shall be binding on the representatives, assigns and successors of Receiving Party.

I/We (Name of Authorised Signatory) , on behalf of Receiving Party hereby agree and undertakes to perform its obligations under this Undertaking and keep Disclosing Party Indemnified against any loss whatsoever. In case of any breach of any obligation, Receiving Party shall be liable and responsible for any legal action that may ensue.

This Undertaking is signed by Receiving Party through its authorized representative.

Place :

Date :

Signature of the Authorised signatory
with Name & Designation and Seal.

Note:

1. This Undertaking is signed by Receiving Party through its authorized representative.
2. Power of Attorney of the persons signing on behalf of the Bidder / Contractor (Receiving Party) is to be furnished by the bidder and to be enclosed with the signed Non-Disclosure Undertaking.

Milestone Schedule

To,
AGM(Corp. Matls)
NTPC Limited
EOC, Plot A-8A, Sec-24
NOIDA - 201 301

Ref: Tender No. : dated for “.....” Package

Dear Sirs,

We hereby declare that the following completion shall be followed by us in supplying the materials under the package. The period is commencing from the date of Notification of Award.

Sl No	Activity	Activity Target (in no. of Months from post award)
1.	Kick off meeting at site identifying the phases of project along with the units, identification of tag list with KKS/address in existing as built logics required in APC, familiarization with existing controls & operation philosophy of stage-I & stage-II. Modbus prototype communication test in C&I Lab with procontrol/maxDNA/Ovation with test hardware.	0.5
2.	Supply: Supply of complete hardware & software for first Unit	1
3.	Installation: Installation of software and interface testing for first Unit	1.5
4.	Commissioning: Commissioning of the System in first Unit	2.5
5.	Training of Employers employees phase-I	3
6.	SAT (Site acceptance testing) for Performance Testing: Performance Testing of System in first Unit	5
7.	For Second, third and fourth Unit: Phase wise installation, commissioning and SAT for performance testing in other three	12

	units	
8.	Continuous running performance testing of system	15
9.	Training of Employers employees Phase-II	After completion of installation of the system in each unit of each stage.
10.	Completion of facilities	16
11.	Final Documentation & handover of the system to the employer	18

Date :

(Signature).....

Place :

(Printed Name).....

(Designation).....

(Common Seal).....

E) BRANCH CODE

--	--	--	--	--	--	--	--	--	--	--	--	--	--	--	--	--	--	--	--

F) 9 DIGIT MICR CODE OF THE BANK BRANCH (ENCLOSE COPY OF A CANCELLED CHEQUE)

--	--	--	--	--	--	--	--	--	--	--	--	--	--	--	--	--	--	--	--

G) 11 DIGIT IFSC CODE OF THE BANK

--	--	--	--	--	--	--	--	--	--	--	--	--	--	--	--	--	--	--	--	--

H) BANK ACCOUNT NUMBER

--	--	--	--	--	--	--	--	--	--	--	--	--	--	--	--	--	--	--	--	--

I) BANK ACCOUNT TYPE (TICK ONE)

NG	RENT	SAVING	CREDIT	DEBIT
----	------	--------	--------	-------

IF OTHERS, SPECIFY

--	--	--	--	--	--	--	--	--	--	--	--	--	--	--	--	--	--	--	--	--

5. PERMANENT ACCOUNT NUMBER (PAN)

--	--	--	--	--	--	--	--	--	--	--	--	--	--	--	--	--	--	--	--	--

6. E-MAIL Address for Intimation regarding release of payments

--	--	--	--	--	--	--	--	--	--	--	--	--	--	--	--	--	--	--	--	--

I/We hereby declare that the particulars given above are correct and complete. If the transaction is delayed or credit is not affected at all for reasons of incomplete or incorrect information, I/We would not hold the Owner responsible

DATE

--	--	--	--	--	--	--	--	--	--	--	--	--	--	--	--	--	--	--	--	--

SIGNATURE

(AUTHORISED SIGNATORY)

Name:

OFFICIAL STAMP

BANK CERTIFICATION:

It is certified that above mentioned beneficiary holds a bank account no..... with our branch and the Bank particulars mentioned above are correct.

DATE

--	--	--	--	--	--

SIGNATURE
(AUTHORISED SIGNATORY)
Authorisation no.:

Name:

Encl: Blank Cheque

OFFICIAL STAMP

DETAILS OF PAN, TIN and SERVICE TAX REGN.
(For Indian Bidder)

To

AGM (CMM - CMPG)
NTPC Limited
Plot A – 8A, Sector – 24
Noida – 201301

Dear Sir,

The details of our registration in line with the various authorities are as under:

a) PAN number

Our PAN number is as under:

Permanent Account Number	
---------------------------------	--

Note: Copy of card indicating PAN number duly attested by the bidder under his seal and signature to be submitted.

b) Service Tax number (if applicable):

Our **Service Tax** is

Service Tax Number	
---------------------------	--

Note : Copy of registration with up to amendment to be enclosed.

c) TIN (must for UP registered vendors)

Our TIN number is as under:

TIN	
------------	--

Note: Copy of registration with up to amendment to be enclosed.

d) Sales Tax Number

Our Sales Tax numbers are as under:

CST number	
Local Sales Tax number	

Note: Copy of sales tax registration to be enclosed.

Date

Signature

Printed Name

Place

Designation

Company Seal

**CERTIFICATE FOR COMPLIANCE
TO
ALL PROVISIONS OF BIDDING DOCUMENTS**

(Certificate of "NIL" Deviation)

Towards

COMPLIANT BID

(to be accepted on the system)

Through Button or a Tab under 'Attributes'

To
**AGM(Corp. Matls)
NTPC Limited,
EOC , Plot A-8A ,Sec 24
NOIDA - 201 301**

Dear Sir,

1. With reference to our Bid submitted against the tender, we hereby confirm that we comply with all terms, conditions and specifications of the Bidding Documents read in conjunction with Amendment(s) / Clarification(s) / Addenda/Errata (if any) issued by the Employer prior to opening of Techno-Commercial Bids and the same has been taken into consideration while making our Techno-Commercial Bid & Price Bid and we declare that we have not taken any deviation in this regard.

2. We understand that in case the Products and/or Services offered do not meet the Technical requirements, then our bid shall be rejected as Technically non-responsive.

We also confirm that in case we refuse to withdraw additional conditions/deviations/variations/exception, implicit or explicit, found anywhere in the techno-commercial bid, our bid shall be rejected as Technically non-responsive.

We further confirm that if any deviation/variation in any form is found in our Price Bid, the EMD shall be forfeited.

(Acceptance to be given On Line on the system)

FORM OF ACCEPTANCE OF FRAUD PREVENTION POLICY

(to be accepted on the system)

Through Button or a Tab under 'Attributes'

To
AGM(Corp. Matls)
NTPC Limited,
EOC , Plot A-8A ,Sec 24,
NOIDA - 201 301

Dear Sir,

We have read the contents of the Fraud Prevention Policy of NTPC displayed on its tender website <http://www.ntpctender.com> and undertake that we along with our associate / subcontractors / sub-vendors / consultants / service providers shall strictly abide by the provisions of the Fraud Prevention policy of NTPC.

(Acceptance to be given On Line on the system)

DECLARATION ON BANNING POLICY

(To be accepted on the system under attributes)

Through Button or a Tab

To

**AGM(Corp. Matls)
NTPC Limited,
EOC , Plot A-8A, Sec 24,
NOIDA - 201 301**

1) We have read the contents of the Banning Policy of NTPC displayed on its tender website <http://www.ntpctender.com> and agree to abide by this policy. Further, in terms of requirement under Banning policy we hereby declare the following:

- a) We have not been Banned/Blacklisted as on date of submission of bid by Ministry of Power or Government of India.
- b) We have not employed any public servant dismissed/removed or person convicted for an offence involving corruption or abetment of such offences.
- c) Our Director(s)/Owner(s)/Proprietor/Partner(s) have not been convicted by any court of law for offences involving corrupt and fraudulent practices including moral turpitude in relation to business dealings with Government of India or NTPC or NTPC's group companies during the last five years.

2) We further declare as under:

that if at any point subsequent to award of Contract, the declarations given above are found to be incorrect, NTPC Limited shall have the full right to terminate the Contract and take any action as per applicable laws for breach of contract including forfeiture of Bid Security/Performance Bank Guarantee.

(Acceptance to be given On Line on the system under 'Attributes')

CERTIFICATE OF COMPLIANCE ON QUALIFYING REQUIREMENT

(To be accepted on the system under attributes)

Through Button or a Tab

To
AGM(Corp. Matls)
NTPC Limited
EOC,
Plot A-8A, Sec-24,
NOIDA - 201 301

Dear Sir,

With reference to our Bid proposal for the package we hereby confirm that the number of reference Work Orders/Purchase Orders/Letter of Awards/Contract Agreements quoted by us in Attachment 7A in the bid, for establishing compliance to the specified Qualifying Requirements (QR) are not more than the number specified in Special Purchase Conditions (SPC).

We confirm that the reference Work Orders/Purchase Orders/Letter of Awards/Contract Agreements declared more than the number specified in the Special Purchase Conditions (SPC) shall not be considered for evaluation/establishing compliance to Qualifying Requirements (QR).

We further confirm that no change or substitution in respect of reference Work Orders/Purchase Orders/Letter of Awards/Contract Agreements as declared in our bid by new/additional Work Orders/Purchase Orders/Letter of Awards/Contract Agreements for meeting the specific Qualifying Requirement (QR) shall be offered by us.

(Acceptance to be given On Line on the system under 'Attributes')

**FORM OF TRUST RECEIPT FOR ITEM,
EQUIPMENT AND MATERIALS RECEIVED**

We M/s (Contractor’s Name)..... having our Principal place of business athaving been awarded a Contract No..... dated for (Contract Name)..... by (Name of Employer)

We do hereby acknowledge the receipt of the Item , Equipment and Materials as are fully described and mentioned under Documents of Title/RR/LR etc. and in the schedule annexed hereto, which shall form an integral part of this receipt as “Trustee” of (Name of Employer). The aforesaid materials etc. so received by us shall be exclusively used in the successful performance of the aforesaid Contract and for no other purpose whatsoever. We undertake not to create any charge, lien or encumbrance over the aforesaid materials etc, in favour of any other person/institution(s)/Banks.

For M/s
(Contractor’s Name)

Dated :

(AUTHORISED SIGNATORY)

**FORM OF INDEMNITY BOND TO BE EXECUTED
BY THE CONTRACTOR FOR THE EQUIPMENT
HANDLED OVER BY THE EMPLOYER
FOR PERFORMANCE OF ITS CONTRACT
(Entire Equipment Consignment in one lot)
(On non-Judicial stamp paper of appropriate value)**

INDEMNITY BOND

THIS INDEMNITY BOND is made this.....day.....
of.....20 .. by.....(Contractor’s Name) a
Company registered under the Companies Act, 1956/Partnership firm/Proprietary concern having its
Registered Office at(hereinafter called as ‘Contractor’ or “Obligor” which
expression shall include its successors and permitted assigns) in favour of (Name of Employer), a
Company incorporated under the Companies Act, 1956 having its Registered Office at and its
project at.....(hereinafter called “.....”..{Abbreviated name of
the Employer}” which expression shall include its successors and assigns)..... :

WHEREAS@... .. has awarded to the Contractor a Contract
for ..vide its Notification of Award/Contract No.....dated and its Amendment No. ..
..... and Amendment No... .., (applicable when
amendments have been issued) (hereinafter called the Contract”) in terms of which@... . is
required to hand over various Equipments to the Contractor for execution of the Contract.

And WHEREAS by virtue of Clause No... .. of the said Contract, the
Contractor is required to execute an Indemnity Bond in favour of.....@... ..for the
Items/Equipments handed over to it by@.....for the
purpose of performance of the Contract/Installation/Commissioning portion of the contract (hereinafter
called the “Items/Equipments”)

AND THEREFORE, This Indemnity Bond witnesseth as follows:

- 1. That in consideration of various Items/Equipments as mentioned in the Contract, valued
at (Currency and amount in Figures)... (Currency and amount in words)
.....handed over to the Contractor for the purpose of performance of the Contract, the
Contractor hereby undertakes to indemnify and shall keep@..... . indemnified, for
the full value of the Items/Equipments. The Contractor hereby acknowledges actual receipt of
the Items/Equipment etc. as per despatch title documents handed over to the Contractor as
detailed in the Schedule appended hereto. The Contractor shall hold such Equipment etc. in
trust as a “Trustee” for and on behalf of@.....

@ Fill in abbreviated name of Employer

2. That the Contractor is obliged and shall remain absolutely responsible for the safe transit/protection and custody of the Items/Equipment at@..... project site against all risks whatsoever till the Equipments are duly used/erected in accordance with the terms of the Contract and the plant/package duly erected and commissioned in accordance with the terms of the Contract is taken over by@.....The Contractor undertakes to keep.....@.....harmless against any loss or damage that may be caused to the Equipments.

3. The Contractor undertakes that the Equipments shall be used exclusively for the performance/execution of the Contract strictly in accordance with its terms and conditions and no part of the equipment shall be utilized for any other work of purpose whatsoever. It is clearly understood by the Contractor that non-observance of the obligations under this Indemnity Bond by the Contractor shall inter-alia constitute a criminal breach of trust on the part of the Contractor for all intents and purpose including legal/penal consequences.

4. That.....@.....is and shall remain the exclusive owner of the equipments free from all encumbrances, charges or liens of any kind, whatsoever. The Items/Equipments shall at all times be open to inspection and checking by the Project Manager or other employees/agents authorised by him in this regard.

Further,.....@.....shall always be free at all times to take possession of the Items/Equipments in whatever form the Items/Equipments may be, if in its opinion, the items/equipments are likely to be endangered, mis-utilized or converted to uses other than those specified in the Contract, by any acts of omission or commission on the part of the Contractor or any other person or on account of any reason whatsoever and the Contractor binds himself and undertakes to comply with the directions of demand of@.... to return the Items/Equipments without any demur or reservation.

5. That this Indemnity Bond is irrevocable. If at any time any loss or damage occurs to the Items/Equipments or the same or any part thereof is mis-utilized in any manner whatsoever, then the Contractor hereby agrees that the decision of the Project Manager of.....@.....as to assessment of loss or damage to the Items/Equipment shall be final and binding on the Contractor. The Contractor binds itself and undertakes to replace the lost and/or damaged Items/Equipments at its own cost and/or shall pay the amount of loss to@..... without any demur, reservation or protest. This is without prejudice to any other right or remedy that may be available to.....@.....against the Contractor under the Contract and under this Indemnity Bond.

6. NOW THE CONDITION of this Bond is that if the Contractor shall duly and punctually comply with the terms and conditions of this Bond to the satisfaction of.....@.....THEN, the above Bond shall be void, but otherwise, it shall remain in full force and virtue.

@ Fill in abbreviated name of Employer

IN WITNESS WHEREOF, the Contractor has hereunto set its hand through its authorized representative under the common seal of the Company, the day, month and year first above mentioned.

SCHEDULE

Particulars of the Items/Equipments handed over	Quantity	Particulars of Dispatch title Documents RR/GR/ Bill of lading No & Date	Value of the Items/Equipments	Signature of Attorney in token of receipt
---	----------	--	-------------------------------	---

For and on behalf of

.....
(Contractor's Name)

WITNESS :

- | | | | |
|----|----|-----------------|--|
| 1. | 1. | Signature..... | Signature |
| | 2. | Name | Name |
| | 3. | Address | Designation of
Authorised representative* |
| 2. | 1. | Signature | (Common Seal) |
| | 2. | Name | (In case of Company) |
| | 3. | Address | |

* Indemnity Bond are to be executed by the authorised person and (i) in case of contracting Company under common seal of the Company or (ii) having the Power of Attorney issued under common seal of the company with authority to execute Indemnity Bond, (iii) In case of (ii), the original Power of Attorney if it is specifically for this Contract or a photostat copy of the Power of Attorney if it is General Power of Attorney and such documents should be attached to Indemnity Bond.

FORM OF AUTHORISATION LETTER

(NAME OF EMPLOYER)

(PROJECT)

REF. NO. :

DATE :

To,

M/s (Contractor's Name).....

Ref : Contract No..... Dated

forawarded by (Name of Employer)

Dear Sirs,

Kindly refer to Contract No..... Dated for(Contract Name) You are hereby authorised on behalf of(Name of Employer) having its registered office atand its Project at to take physical delivery of items/materials/equipments covered under despatch Document/ Consignment Note no..... *dated and as detailed in the enclosed Schedule for the sole purpose of successful performance of the aforesaid contract and for no other purposes, whatsoever.

(Signature of Project Authority)

(Designation :

Date

ENCL : as above

* Mention LR/RR No.

**SCHEDULE OF ITEMS/MATERIAL/EQUIPMENT COVERED UNDER
DESPATCH TITLE DOCUMENT (RR NO./ LR NO.)**

Sl. No.	Contract Name	NOA No./ Contract Agreement No.	Description of Items/Materials/ Equipments	Spec. No.	Qty.	Value	Remarks
---------	---------------	---------------------------------	--	-----------	------	-------	---------

(SIGNATURE OF THE PROJECT AUTHORITY)

(Designation).....

Date).....

NIT NO:
(Details in respect of Local Agent with Fees)

Bidder's Name and Address :

To
AGM(CM)
NTPC Limited,
Plot A-8A, Sector-24
Noida - 201301

Dear Sir,

We furnish below the following information in respect of our local agent :

(i) Name and address of the local agent
.....
.....
.....

(ii) Services to be rendered by the local agent
.....
.....
.....

(iii) Amount
.....
.....

Date :
Place : (Printed Name)
(Designation).....

NIT NO:
(Bought out items to be directly despatched by Sub-Vendors to site)

Bidder's Name and Address :

To
AGM(CM)
NTPC Limited,
Plot A-8A, Sector-24
Noida - 201301

We declare that the following are the details of equipment & materials including mandatory spares to be directly despatched from the works of our sub-contractors/sub-vendors and/or from the works of sub-contractors/sub-vendors of our Assignee (applicable for foreign bidder) to Project Site.

Sl. No.	Description of Equipment/ Spares/Material	Weight/ Qty. (Tonnes)/ (Nos.)	Ex-works price of Bought out Items
(1)	(2)	(3)	(4)

Date :

Place : (PrintedName)

(Designation)

- Note :**
- Continuation sheets of like size and format, may be used as per Bidder's requirement and shall be annexed to this Attachment.
 - The above is applicable for supply of plant and equipment including spares on Ex-works (India) Basis.

PRICE SCHEDULES

(Uploaded in C-Folder as separate Excel file)

ATTACHMENT - 25

FORM OF CONTRACT AGREEMENT

FORM OF CONTRACT AGREEMENT

THIS CONTRACT AGREEMENT is made the _____ day of _____
20_____

BETWEEN

(1) NTPC Ltd. a corporation incorporated under the laws of India and having its principal place of business at NTPC Bhawan, Core 7, SCOPE Complex, 7, Institutional Area, Lodi Road, New Delhi - 110 003 (hereinafter called "the NTPC Ltd."),

and

(2) [name of Contractor], a corporation incorporated under the laws of [country of Contractor] and having its principal place of business at [address of Contractor] (hereinafter called "the Contractor")

WHEREAS the NTPC Ltd. desires to engage the Contractor for “**Advanced Process Control – (APC) Package for Simhadri Stg-I (2x500 MW) & Stg-II (2x500 MW)**” Package and the Contractor have agreed to such engagement upon and subject to the terms and conditions hereinafter appearing.

NOW IT IS HEREBY AGREED as follows:

Article 1 Contract Documents

1.1 Contract Documents

The following documents shall constitute the Contract between the NTPC Ltd. and the Contractor, and each shall be read and construed as an integral part of the Contract:

- (a) This Contract Agreement
- (b) Letter of Award/Purchase Order
- (c) Amendment to Bidding Documents
- (d) Volume-II Special Purchase Conditions (SPC)
- (e) Volume-III Technical Specifications and Drawings
- (f) Volume- I General Purchase Conditions (GPC)
- (g) The Bid and Price Schedules submitted by the Contractor
- (h) Integrity Pact (IP) signed between the NTPC Ltd. & the Bidder/Contractor.

1.2 Order of Precedence

In the event of any ambiguity or conflict between the Contract Documents listed above, the order of precedence shall be the order in which the Contract Documents are listed in Article 1.1 (Contract Documents)above.

1.3 Definitions

Capitalized words and phrases used herein shall have the same meanings as are ascribed to them in the General Purchase conditions.

Article 2 Contract Price and Terms of Payment

2.1 **Contract Price** (Reference GCC Clause 11)

The NTPC Ltd. hereby agrees to pay to the Contractor the Contract Price in consideration of the performance by the Contractor of its obligations hereunder.

The Contract Price shall be the aggregate of : *[amount of foreign currency in words], {amount in figures},*

and

{amount of local currency in words}, [amount in figures], or such other sums as may be determined in accordance with the terms and conditions of the contract.

2.2 **Terms of Payment** (Reference SPC Clause 39.0)

The terms and procedures of payment according to which the NTPC Ltd. will reimburse the Contractor are given in Clause 39.0 of Special Purchase Conditions.

Article 3 Effective Date for Determining Time for completion

3.1 The time for of completion work shall be determined from the date of issue of Letter of Award/Purchase Order provided all of the following conditions have been fulfilled within a period of 30 days from the date of the said Letter of Award/Purchase Order:

(a) This Contract Agreement has been duly executed for and on behalf of the Employer and the Contractor;

(b) The Contractor has submitted to the Employer the performance security and Security towards faithful performance of the Deed(s) of Joint undertaking (if applicable);

Each party shall use its best efforts to fulfill the above conditions for which it is responsible as soon as practicable.

3.2 If the conditions listed under 3.1 are not fulfilled within 30 days from the date of Letter of Award/Purchase Order because of reasons attributable to the Employer, the Contract would become effective only from the date of fulfillment of all the above mentioned conditions and, the parties shall discuss and agree on an equitable adjustment to the Time for Completion and/or other relevant conditions of the Contract.

3.3 However, if any of the conditions listed under 3.1 above are not fulfilled within 30 days from the date of Letter of Award/Purchase Order because of the reasons attributable to the contractor , the contract will become effective from the date of Letter of Award/Purchase Order. In this case, time of completion shall not be adjusted.

Article 4. It is expressly understood and agreed by and between the Contractor and the NTPC Ltd. that the NTPC Ltd. is entering into this Agreement solely on its own behalf and not on behalf of any other person or entity. In particular it is expressly understood and agreed that the Government of India is not a party to this Agreement and has no liabilities, obligations or rights hereunder. It is expressly

understood and agreed that the NTPC Ltd. is an Independent legal entity with power and authority to enter into contracts solely on its own behalf under the applicable laws of India and the general principles of Contract Law. The Contractor expressly agrees, acknowledges and understands that the NTPC Ltd. is not an Agent, Representative or Delegate of the Govt. of India. It is Further understood and agreed that the Government of India is not and shall not be liable for any acts, omissions, commissions, breaches or other wrongs arising out of the Contract. Accordingly, the Contractor expressly waives, releases and foregoes any and all actions or claims, including cross claims, impleader claims or counter claims against the Government of India arising out of this Contract and covenants not to sue the Government of India as to any manner, claim, cause of action or thing whatsoever arising of or under this Agreement.

IN WITNESS WHEREOF the NTPC Ltd. and the Contractor have caused this Agreement to be duly executed by their duly authorized representatives the day and year first above written.

Signed by for and on behalf of the NTPC Ltd.

[Signature]

[Title]

in the presence of _____

Signed by for and on behalf of the Contractor

[Signature]

[Title]

in the presence of _____

CONTRACT AGREEMENT

dated the _____ day of _____, 20 _____

BETWEEN

["the NTPC Ltd. ']

and

["the Contractor ']

electronic tendering

e-procurement (SRM)

Volume-II

Section-I

Special Purchase Conditions (SPC) "e-tendering"

Part A,.... SPC for e-tendering

Part B,.... SPC for Reverse Auction



SPECIAL PURCHASE CONDITIONS (SPC)

(The conditions in this section will supersede any other related conditions anywhere else in this tender document)

Special Purchase Conditions – Volume II section I Part - A

1.0	TYPE OF BIDDING	Single stage Two Envelope bidding without Reverse Auction on fully compliant basis.
2.0	REVERSE AUCTION	Not Applicable.
3.0	VALIDITY OF OFFER	<p>a) The Bid initially shall remain valid and open for acceptance for one hundred & eighty (180) days from the date of opening of Techno-Commercial Bid. The bid valid for shorter period shall be rejected by the Employer as being non-responsive.</p> <p>b) In exceptional circumstances, the Employer may solicit the Bidder's consent to an extension of the bid validity period. The request and responses thereto shall be made in writing by post or by telefax followed by post confirmation. If a Bidder accepts to extend the period of bid validity, the validity of bid security shall also be suitably extended. A Bidder may refuse the request without forfeiting its bid security. A Bidder granting the request will not be required nor permitted to modify its bid.</p>
4.0	BID SECURITY/ EARNEST MONEY DEPOSIT (EMD)	<p>The Bid Security shall, at the Bidder's option, be in the form of a crossed Demand Draft/ Pay Order/ Banker's Cheque, Irrevocable Letter of Credit or a bank guarantee from any of the banks specified in Bid Data Sheets. In case of foreign bidders, the Bid Security can be from any other bank also in addition to the banks specified in the Bid Data Sheets and if the Bank Guarantee is from a Bank not specified in the Bid Data Sheets, then the Bank Guarantee shall be confirmed by any of the Banks specified in the Bid Data Sheets. The format of the Bank Guarantee or Letter of Credit shall be in accordance with the form of bid security included in the Bidding Documents.</p> <p>The Bid Security, at Bidders option, can also be in the form of E-Payment by Credit Card/Debit card/Net Banking on the NTPC e-tender portal. (Note: Upon successful E-payment on the portal, an e-receipt shall be issued to the bidder by the system, a copy of which is to be submitted by the bidder with the bid as document towards e-payment of EMD).</p> <p>Payable at Noida/New Delhi/Delhi for an amount of Rs. 27,25,000.00 (Rupees Twenty Seven Lakh And Twenty Five Thousand Only) or USD 41,700.00 (USD Forty One Thousand And Seven Hundred Only) in a separate envelope, super scribed on the top as under.</p>



		<p>NIT No. 40086783</p> <p>Package : “”</p> <p>Due Date of Techno-Commercial Bid</p> <p>From (Name of the Bidder).”</p> <hr/> <p>Note: The bid security shall, in case submitted in the form of DD/Bankers Cheque/ Pay Order should be in favour of NTPC Ltd. payable at Noida / New Delhi.</p> <p>Bid security shall be initially valid for a period of two hundred twenty five (225) days from the date of Techno-commercial bid opening. Bid Security shall also be extended based on any Bid validity extension subsequently.</p> <p>Any bid not accompanied by an acceptable Bid Security, in a separate sealed envelope shall be rejected by the Employer as being non-responsive and shall not be opened.</p>												
<p>4.1</p>	<p>CONFIRMATION OF BG THROUGH STRUCTURED FINANCIAL MESSAGING SYSTEM (SFMS)/SWIFT</p>	<p>While issuing the physical BGs, the Bidder’s Bank shall also send electronic message through secure SFMS (in case of BGs issued from within India) or SWIFT (in case of BGs issued from outside India) to Owner’s Beneficiary Bank whose details are provided herein below:</p> <table border="1" data-bbox="646 982 1442 1331"> <tr> <td>i.</td> <td>Bank Name</td> <td>SBI</td> </tr> <tr> <td>ii.</td> <td>Branch</td> <td>Pragati Vihar, Delhi-110003</td> </tr> <tr> <td>iii.</td> <td>Bank Address</td> <td>Pragati Vihar, Core 6, Scope Complex, Lodhi Road, New Delhi-110003</td> </tr> <tr> <td>iv.</td> <td>IFSC Code</td> <td>SBIN0020511</td> </tr> </table> <p>Bidders are advised to ensure that the message is sent by their Bankers. The Bidders must submit the message reference details as part of the bid with the EMD.</p>	i.	Bank Name	SBI	ii.	Branch	Pragati Vihar, Delhi-110003	iii.	Bank Address	Pragati Vihar, Core 6, Scope Complex, Lodhi Road, New Delhi-110003	iv.	IFSC Code	SBIN0020511
i.	Bank Name	SBI												
ii.	Branch	Pragati Vihar, Delhi-110003												
iii.	Bank Address	Pragati Vihar, Core 6, Scope Complex, Lodhi Road, New Delhi-110003												
iv.	IFSC Code	SBIN0020511												
<p>5.0</p>	<p>TRANSFER OF BID DOCUMENTS</p>	<p>Transfer of Bidding documents purchased by one intending bidder to another is not permissible.</p> <p>Documents purchased / downloaded by the intending bidders cannot be transferred.</p>												
<p>6.0</p>	<p>TRANSFER OF OWNERSHIP</p>	<p>(i) Ownership of the Items/ Hardware and software to be imported into the country where the Site is located shall be transferred to the Employer upon loading on to the mode of transport to be used to convey the Items from the country of origin to that country and upon endorsement of despatch document in favour of the Employer.</p> <p>Ownership of the Items/ Hardware and software procured in the</p>												

		<p>country where the Site is located shall be transferred to the Employer when the Items/ Hardware and software are loaded on to the mode of transport to be used to convey the Items from the works to the site and upon endorsement of the despatch documents in favour of the Employer</p> <p>Notwithstanding the transfer of ownership of the Items/ Hardware and software, the responsibility for care and custody thereof together with the risk of loss or damage thereto shall remain with the Contractor hereof until Completion of the contract or the part thereof in which such Items are incorporated.</p> <p>In case of two/three Contracts entered into between the Employer and the Contractor or where the Employer hands over his Items/ Hardware and software to the Contractor for executing the Contract, then the Contractor shall at the time of taking delivery of the Items/ Hardware and software through Bill of Lading or other despatch documents furnish Trust Receipt for Items and Materials and also execute an Indemnity Bond in favour of the Employer in the form acceptable to Employer for keeping the Items in safe custody and to utilise the same exclusively for the purpose of the said Contract. Proforma for the Trust Receipt and Indemnity Bond is enclosed under Volume-I, Section – IV (Forms /Bid Data Sheet). The Employer shall also issue a separate Authorisation Letter to the Contractor to enable him to take physical delivery of Items/ Hardware and software and materials from the Employer as per proforma enclosed under Volume-I, Section – IV (Forms /Bid Data Sheet).</p> <p>The Contractor shall at its own risk and expense transport all the Items/ Hardware and software and the Contractor’s Equipment to the Site by the mode of transport that the Contractor judges most suitable under all the circumstances.</p> <p>The Contractor shall ensure that all the Items/ Hardware and software are suitably packed and protected to prevent damage or deterioration during its transportation to site, handling and storage at site till the time of its installation.</p> <p>The Contractor shall be responsible for obtaining, if necessary, approvals from the authorities for transportation of the Items/ Hardware and software and the Contractor’s Equipment to the Site. The Contractor shall indemnify and hold harmless the Employer from and against any claim for damage to roads, bridges or any other traffic facilities that may be caused by the transport of the Items/ Hardware and software and the Contractor’s Equipment to the Site.</p> <p>Further, in case of all components, Items/ Hardware and software and materials identified by the contractor and NTPC to be despatched directly from the sub-vendor’s work to NTPC site in a state different from the state wherein sub-vendor’s works are located, the contractor will effect sale in transit. For effecting the sale in transit, the contractor shall ensure that his sub-vendor raises invoices in the</p>
--	--	---

		<p>contractor's name (and not in the name of NTPC) and obtains GR/LR/RR in the name of Contractor (and not in the name of NTPC). The Contractor shall further ensure that he endorses the GR/LR/RR in the name of NTPC during transit of the Items/ Hardware and software before the delivery of Items/ Hardware and software is taken by NTPC.</p> <p>(i) Ownership of the Contractor's Equipment used by the Contractor in connection with the Contract shall remain with the Contractor.</p> <p>(ii) Ownership of any Material in excess of the requirements for the completion of work shall revert to the Contractor upon completion of work or at such earlier time when the Employer and the Contractor agree that the Material in question is no longer required for the work, provided quantity of any Material specifically stipulated in the Contract shall be the property of the Employer whether or not incorporated in the work.</p>	
7.0	DEVIATIONS / EXCLUSIONS	<p>No deviation, whatsoever, is permitted by EMPLOYER to any provision of Bidding Documents.</p> <p>The Bidders are advised that while making their Bids and quoting prices, all conditions are appropriately taken into consideration. Bidders shall certify their compliance to the complete Bidding Documents as per Certificate at Attachment 14 of Volume I Section IV by accepting the following General Technical Evaluation (GTE) of the Tender:</p> <p>"Do you certify full compliance to all provisions of Bid Doc?"</p> <p>In case the Products and/or Services offered do not meet the Technical requirements, the bid shall be rejected as Technically non-responsive.</p> <p>Bidders may note that in case the Bidder refuses to withdraw additional conditions/deviations/ variations/exception, implicit or explicit, found anywhere in the techno-commercial bid, the bid shall be rejected as Technically non-responsive.</p> <p>Bidders may also note that any deviation/variation in any form in the Price Bid shall result in forfeiture of EMD.</p>	
8.0	QUALIFYING REQUIREMENTS {As stipulated at para 7.0 of NIT}	7.1.0	Technical Criteria:
		7.1.1	Route-1 (For Bidder) The Bidder should meet (A) and (B) below.
		7.1.1 (A)	The Bidder should have Engineered, Manufactured, Supplied, Erected/Supervised Erection & Commissioned/Supervised Commissioning of Distributed Digital Control, Monitoring & Information system (DDCMIS) / Distributed Control System (DCS), which should have been in successful operation in at least one (1) unit of a coal fired station having unit rating of 200 MW or above for a period of not less than one (1) year prior to the date of bid opening.

			<p>The DDCMIS/DCS above should necessarily include as a minimum,</p> <ul style="list-style-type: none"> a. Modulating control for Steam-Generator (SG) b. Modulating control for Feedwater/ Condensate cycle (SG) c. Binary control of the auxiliaries for Steam-Generator (SG) d. Binary control of the auxiliaries for Turbine-Generator (TG) <p>The Bidder or its group company should have an established DDCMIS hardware and software service centre in India working for at least five (5) years prior to the date of bid opening.</p>
		<p>7.1.1 (B)</p>	<p>The Bidder should have Supplied and Commissioned Advanced Process Control software for the following:</p> <ul style="list-style-type: none"> (B1) Combustion optimization, in closed loop which should have been in successful operation in at least one (1) unit of pulverized coal fired station having unit rating of 200 MW or above, for a period of not less than one (1) year prior to the date of bid opening. (B2) Soot Blowing Optimization, in closed loop which should have been in successful operation in at least one (1) unit of pulverized coal fired station having unit rating of 200 MW or above, for a period of not less than one (1) year prior to the date of bid opening. (B3) Faster load Ramp-up/Ramp-down, in closed loop which should have been in successful operation in at least one (1) unit of pulverized coal fired station having unit rating of 200 MW or above, for a period of not less than one (1) year prior to the date of bid opening. <p>OR</p> <p>SH/RH Temperature Excursion Reduction, in closed loop which should have been in successful operation in at least one (1) unit of pulverized coal fired station having unit rating of 200 MW or above, for a period of not less than one (1) year prior to the date of</p>

			bid opening.
		7.1.2	<p>Route-2 (For Bidder with Collaborator(s)/Associate(s))</p> <p>The Bidder, who meets the requirement at 7.1.1 (A) above but does not meet one or more of the requirements at 7.1.1 (B) above (i.e. B1 to B3), can also participate provided it associates with APC supplier/suppliers who meet the requirement(s) at 7.1.1 (B) above (i.e. B1 or B2 or B3 or any combination thereof) which the Bidder does not meet, so that complete requirements of 7.1.1 (A) and 7.1.1 (B) (i.e. B1, B2 & B3) above are met by the Bidder along with its Associate(s).</p> <p>In such a case, the Bidder should furnish along with its bid a Deed of Joint Undertaking (DJU), jointly executed by it along with each of its Collaborator(s)/Associate(s) for full responsibility of the performance of the respective Advanced Process Control software as per format enclosed with the bidding document in which the Collaborator(s)/Associate(s) and the bidder shall be jointly & severally liable to the Employer to perform all contractual obligations for the scope of work for which the Collaborator(s)/Associate(s) is/are responsible. This Deed of Joint Undertaking should be submitted along with the Bid, failing which the Bidder shall be disqualified and its bid shall be rejected. In case of award, the Collaborator(s)/Associate(s) shall be required to furnish an on-demand Bank Guarantee as per the format enclosed with the bidding documents for a value equal to 5% (five percent) of the total contract price in addition to the Contract Performance Security to be furnished by the bidder.</p>
			<p>Notes:</p> <ol style="list-style-type: none"> Advanced Process Control (APC) shall mean the set of techniques which use a multiple input multiple output predictive model for improving the existing performance of the control loops w.r.t the desired objective (i.e. efficiency improvement or emissions reduction etc). The model can be first principles based, empirical or ANN (artificial neural network) or fuzzy logic based. Combustion Optimization shall include optimizing the flue gas O2 trim, air registers, and feeder rate bias in order to improve heat rate/ reduce NOx. Faster load ramp up/ ramp down shall mean using APC for main steam pressure control loop.

		<ol style="list-style-type: none"> 4. SH/RH temperature excursion reduction shall mean using APC for SH/RH spray control loop. 5. Wherever the term 'coal fired' is appearing above, 'coal' shall be deemed to also include bituminous coal/ sub-bituminous coal/ brown coal/ lignite. 6. The reference plant for 7.1.1 (B) above (i.e. B1, B2 and B3) need not be same. 7. The Advanced Process Control software offered for this package should either be same, as referred at 7.1.1 (B) above (i.e. B1, B2 and B3), or be newer versions or upgrades of the same product or a product whose name has been changed after version/product upgrade. 8. Successful operation at 7.1.1 (B) (B1) to 7.1.1 (B) (B3) above shall mean that the End-user of the reference plant achieved the desired benefit from the respective Advanced Process Control software.
	7.2.0	Financial criteria of Bidder
	7.2.0 (a)	<p>The average annual turnover of the Bidder, in the preceding three (3) financial years as on the date of bid opening, should not be less than ₹ 10.7 Crores (Rupees Ten Crores and Seventy Lacs Only) or in equivalent foreign currency.</p> <p>In case the bidder does not satisfy the average annual turnover criteria, stipulated above on its own, its Holding Company would be required to meet the stipulated turnover requirements as above, provided that the net worth of such Holding Company as on the last day of the preceding financial year is at least equal to or more than the paid-up share capital of the Holding Company. In such an event, the bidder would be required to furnish along with its bid, a Letter of Undertaking from the Holding Company, supported by the Holding Company's Board Resolution as per the format enclosed in the bid documents, pledging unconditional and irrevocable financial support for the execution of the Contract by the Bidder in case of award.</p>
	7.2.0 (b)	<p>The Net Worth of the bidder as on the last day of the preceding financial year should not be less than 100% (hundred percent) of its paid-up share capital. In case the Bidder does not satisfy the Net Worth criteria on its own, it can meet the requirement of Net worth based on the strength of its Subsidiary (ies) and/or Holding Company and/or Subsidiaries of its Holding companies wherever applicable. In such a case, however, the Net worth of the Bidder and its subsidiary (ies) and/or Holding Company and/or subsidiary (ies) of the Holding Company, in combined manner should not be less than 100% (hundred percent) of their</p>

			<p>total paid-up share capital. However individually, their Net worth should not be less than 75% (seventy five percent) of their respective paid-up share capitals.</p> <p>Net worth in combined manner shall be calculated as follows:</p> <p>Net worth (combined) = $(X1+X2+X3) / (Y1+Y2+Y3) \times 100$</p> <p>Where X1, X2, X3 are individual Net worth which should not be less than 75% of the respective paid up share capitals and Y1, Y2, Y3 are individual paid up share capitals.</p>
		<p>7.2.0 (c)</p>	<p>In case the bidder is not able to furnish its audited financial statements on stand alone entity basis, the unaudited unconsolidated financial statements of the bidder can be considered acceptable provided the bidder further furnishes the following documents for substantiation of its qualification:</p> <ul style="list-style-type: none"> (i) Copies of the unaudited unconsolidated financial statements of the bidder along with copies of the audited consolidated financial statements of its Holding Company. (ii) A Certificate from the CEO/CFO of the Holding Company, as per the format enclosed in the bidding documents, stating that the unaudited unconsolidated financial statements form part of the consolidated annual financial statements of the Holding Company. <p>In case where audited results for the last financial year as on the date of bid opening are not available, the financial results certified by a practicing Chartered Accountant shall be considered acceptable. In case, Bidder is not able to submit the certificate from a practicing Chartered Accountant certifying its financial parameters, the audited results for the three consecutive financial years preceding the last financial year shall be considered for evaluating the financial parameters. Further, a Certificate would be required from the CEO/CFO as per the format enclosed in the bid documents stating that the Financial results of the Company are under audit as on the date of bid opening and the Certificate from the practicing Chartered Accountant certifying the financial parameters is not available.</p>
		<p>7.3.0</p>	<p>Financial Criteria of Collaborator(s)/Associate(s) of the Bidder</p>

		<p>7.3.0 (a)</p>	<p>The average annual turnover of the Collaborator/Associate, in the preceding three (3) financial years as on the date of bid opening, should not be less than the following for different Collaborator(s) / Associates(s) as applicable.</p> <table border="1" data-bbox="732 411 1500 1667"> <thead> <tr> <th data-bbox="732 411 954 590">Collaborator(s) / Associate(s)</th> <th data-bbox="954 411 1159 590">Applicable clauses</th> <th data-bbox="1159 411 1500 590">Required annual turnover in Crores Rupees or in equivalent foreign currency</th> </tr> </thead> <tbody> <tr> <td data-bbox="732 590 954 737">APC Supplier</td> <td data-bbox="954 590 1159 737">7.1.1 (B) B1</td> <td data-bbox="1159 590 1500 737">₹ 4.3 Crores (Rupees Four Crores and Thirty Lacs Only)</td> </tr> <tr> <td data-bbox="732 737 954 873">APC Supplier</td> <td data-bbox="954 737 1159 873">7.1.1 (B) B2</td> <td data-bbox="1159 737 1500 873">₹ 4.3 Crores (Rupees Four Crores and Thirty Lacs Only)</td> </tr> <tr> <td data-bbox="732 873 954 1020">APC Supplier</td> <td data-bbox="954 873 1159 1020">7.1.1 (B) B3</td> <td data-bbox="1159 873 1500 1020">₹ 2.7 Crores (Rupees Two Crores and Seventy Lacs Only)</td> </tr> <tr> <td data-bbox="732 1020 954 1167">APC Supplier</td> <td data-bbox="954 1020 1159 1167">7.1.1 (B) B1 & 7.1.1 (B) B2</td> <td data-bbox="1159 1020 1500 1167">₹ 4.3 Crores (Rupees Four Crores and Thirty Lacs Only)</td> </tr> <tr> <td data-bbox="732 1167 954 1314">APC Supplier</td> <td data-bbox="954 1167 1159 1314">7.1.1 (B) B2 & 7.1.1 (B) B3</td> <td data-bbox="1159 1167 1500 1314">₹ 7 Crores (Rupees Seven Crores Only)</td> </tr> <tr> <td data-bbox="732 1314 954 1461">APC Supplier</td> <td data-bbox="954 1314 1159 1461">7.1.1 (B) B1 & 7.1.1 (B) B3</td> <td data-bbox="1159 1314 1500 1461">₹ 7 Crores (Rupees Seven Crores Only)</td> </tr> <tr> <td data-bbox="732 1461 954 1667">APC Supplier</td> <td data-bbox="954 1461 1159 1667">7.1.1 (B) B1 , 7.1.1 (B) B2 & 7.1.1 (B) B3</td> <td data-bbox="1159 1461 1500 1667">₹ 7 Crores (Rupees Seven Crores Only)</td> </tr> </tbody> </table> <p>In case the Collaborator/Associate does not satisfy the average annual turnover criteria, stipulated above on its own, its Holding Company would be required to meet the stipulated turnover requirements as above, provided that the net worth of such Holding Company as on the last day of the preceding financial year is at least equal to or more than the paid-up share</p>	Collaborator(s) / Associate(s)	Applicable clauses	Required annual turnover in Crores Rupees or in equivalent foreign currency	APC Supplier	7.1.1 (B) B1	₹ 4.3 Crores (Rupees Four Crores and Thirty Lacs Only)	APC Supplier	7.1.1 (B) B2	₹ 4.3 Crores (Rupees Four Crores and Thirty Lacs Only)	APC Supplier	7.1.1 (B) B3	₹ 2.7 Crores (Rupees Two Crores and Seventy Lacs Only)	APC Supplier	7.1.1 (B) B1 & 7.1.1 (B) B2	₹ 4.3 Crores (Rupees Four Crores and Thirty Lacs Only)	APC Supplier	7.1.1 (B) B2 & 7.1.1 (B) B3	₹ 7 Crores (Rupees Seven Crores Only)	APC Supplier	7.1.1 (B) B1 & 7.1.1 (B) B3	₹ 7 Crores (Rupees Seven Crores Only)	APC Supplier	7.1.1 (B) B1 , 7.1.1 (B) B2 & 7.1.1 (B) B3	₹ 7 Crores (Rupees Seven Crores Only)
Collaborator(s) / Associate(s)	Applicable clauses	Required annual turnover in Crores Rupees or in equivalent foreign currency																									
APC Supplier	7.1.1 (B) B1	₹ 4.3 Crores (Rupees Four Crores and Thirty Lacs Only)																									
APC Supplier	7.1.1 (B) B2	₹ 4.3 Crores (Rupees Four Crores and Thirty Lacs Only)																									
APC Supplier	7.1.1 (B) B3	₹ 2.7 Crores (Rupees Two Crores and Seventy Lacs Only)																									
APC Supplier	7.1.1 (B) B1 & 7.1.1 (B) B2	₹ 4.3 Crores (Rupees Four Crores and Thirty Lacs Only)																									
APC Supplier	7.1.1 (B) B2 & 7.1.1 (B) B3	₹ 7 Crores (Rupees Seven Crores Only)																									
APC Supplier	7.1.1 (B) B1 & 7.1.1 (B) B3	₹ 7 Crores (Rupees Seven Crores Only)																									
APC Supplier	7.1.1 (B) B1 , 7.1.1 (B) B2 & 7.1.1 (B) B3	₹ 7 Crores (Rupees Seven Crores Only)																									

			<p>capital of the Holding Company. In such an event, the Collaborator/Associate would be required to furnish along with its bid, a Letter of Undertaking from the Holding Company, supported by the Holding Company's Board Resolution as per the format enclosed in the bid documents, pledging unconditional and irrevocable financial support for the execution of the Contract by the Collaborator/Associate in case of award.</p>
		<p>7.3.0 (b)</p>	<p>The Net Worth of the Collaborator/Associate as on the last day of the preceding financial year should not be less than 100% (hundred percent) of its paid-up share capital. In case the Collaborator/Associate does not satisfy the Net Worth criteria on its own, it can meet the requirement of Net worth based on the strength of its Subsidiary(ies) and/or Holding Company and/or Subsidiaries of its Holding companies wherever applicable. In such a case, however, the Net worth of the Collaborator/Associate and its subsidiary(ies) and/or Holding Company and/or subsidiary (ies) of the Holding Company, in combined manner should not be less than 100% (hundred percent) of their total paid-up share capital. However individually, their Net worth should not be less than 75% (seventy five percent) of their respective paid-up share capitals.</p> <p>Net worth in combined manner shall be calculated as follows: Net worth (combined) = $(X1+X2+X3) / (Y1+Y2+Y3) \times 100$ Where X1, X2, X3 are individual Net worth which should not be less than 75% of the respective paid up share capitals and Y1, Y2, Y3 are individual paid up share capitals.</p>
		<p>7.3.0 (c)</p>	<p>In case the Collaborator/Associate is not able to furnish its audited financial statements on stand alone entity basis, the unaudited unconsolidated financial statements of the Collaborator/Associate can be considered acceptable provided the Collaborator/Associate further furnishes the following documents for substantiation of its qualification:</p> <ul style="list-style-type: none"> (i) Copies of the unaudited unconsolidated financial statements of the Collaborator/Associate along with copies of the audited consolidated financial statements of its Holding Company. (ii) A Certificate from the CEO/CFO of the Holding Company, as per the format enclosed in the bidding documents, stating that the unaudited unconsolidated financial statements form part

		<p>of the consolidated annual financial statements of the Holding Company.</p> <p>In case where audited results for the last financial year as on the date of bid opening are not available, the financial results certified by a practicing Chartered Accountant shall be considered acceptable. In case, Collaborator/Associate is not able to submit the certificate from a practicing Chartered Accountant certifying its financial parameters, the audited results for the three consecutive financial years preceding the last financial year shall be considered for evaluating the financial parameters. Further, a Certificate would be required from the CEO/CFO as per the format enclosed in the bidding documents stating that the Financial results of the Company are under audit as on the date of bid opening and the Certificate from the practicing Chartered Accountant certifying the financial parameters is not available.</p>							
			<p>NOTES:</p> <p>(i) Net worth means the sum total of the paid up share capital and free reserves. Free reserve means all reserves credited out of the profits and share premium account but does not include reserves credited out of the revaluation of the assets, write back of depreciation provision and amalgamation. Further any debit balance of Profit and Loss account and miscellaneous expenses to the extent not adjusted or written off, if any, shall be reduced from reserves and surplus.</p> <p>(ii) Other income shall not be considered for arriving at annual turnover.</p> <p>(iii) "Holding Company" and "Subsidiary Company" shall have the meaning ascribed to them as per Companies Act of India.</p> <p>(iv) For annual turnover indicated in foreign currency, the exchange rate as on seven (7) days prior to the date of bid opening shall be used.</p>						
<p>8.1</p>	<p>Supporting Document to be submitted in support of QR:</p>	<p>Supporting Document to be submitted in support of QR:</p> <p>The bidder should submit the Company Registration certificate / certificate of incorporation/ Authorized by the OEM etc.</p> <table border="1" data-bbox="597 1801 1502 1900"> <thead> <tr> <th data-bbox="597 1801 695 1900">SL. NO.</th> <th data-bbox="695 1801 829 1900">NIT CLAUSE</th> <th data-bbox="829 1801 1502 1900">DOCUMENT TO BE SUBMITTED</th> </tr> </thead> <tbody> <tr> <td> </td> <td> </td> <td> </td> </tr> </tbody> </table>		SL. NO.	NIT CLAUSE	DOCUMENT TO BE SUBMITTED			
SL. NO.	NIT CLAUSE	DOCUMENT TO BE SUBMITTED							

		NO	
1	7.1.1 (A)		<ol style="list-style-type: none"> 1. Documentary evidence including but not limited to relevant portion of Letter of Award/Contract Agreement/ Order, in case the award for the reference works has been received by the Bidder either directly from owner of plant or any other intermediary organization. 2. End user certificate / End User Communication through mail from such owner of plant or the intermediary organization to be furnished by bidder along with Techno-Commercial Bid in support of the claim of Bidder's claim of meeting requirement at clause 7.1.1 (A) of NIT, as the case may be. 3. In case, award for the reference works has been received by the Bidder from any other intermediary organization, confirmation from owner of the plant shall also be furnished by the Bidder. 4. In case, Bidder's group company has an established DDCMIS hardware and software service centre in India working for at least five (5) years prior to the date of bid opening, documentary evidence to be furnished by bidder along with Techno-Commercial Bid to establish relation between Bidder and its group company.
2	7.1.1 (B)		<p>Bidder to produce End user certificate / End User Communication through mail from the referenced station(s) mentioned in the Bid stating that that bidder is meeting all requirement of as per NIT clause 7.1.1 (B) in official letter head or through official e-mail ID.</p> <p>Suggested format of End-User /Client Certificate stating that that bidder is meeting all requirement of as per NIT clause 7.1.1(B) (B1)/ 7.1.1(B) (B2)/ 7.1.1(B) (B3) are enclosed.</p>
3	7.1.2		<ol style="list-style-type: none"> 1. Bidder to produce the documents mentioned in sl. No. 1 & 2 above in favour of itself and its

				<p>associate.</p> <p>2. Bidder furnishes a Deed of Joint Undertaking jointly executed by it and its Associate as per format enclosed in the bidding document.</p>
		4	7.2.0 (a)	<p>Annual Report for the preceding three completed Financial years as on date of Techno Commercial Bid opening to be submitted. As per NIT vide clause no. 7.2.0 (a), if applicable, a Letter of Undertaking from the Holding Company, a Certificate from the CEO/CFO of the Holding Company and a Certificate from the CEO/CFO of the bidder to be submitted along with the bid.</p>
		5	7.2.0 (b)	<p>Annual Report for the last Financial years as on date of Techno Commercial Bid opening to be submitted. As per NIT vide clause no. 7.2.0 (b) , if applicable, Annual Report of of its Subsidiary (ies) and/or Holding Company and/or Subsidiaries of its Holding companies for the last Financial years as on date of Techno Commercial Bid opening to be submitted.</p>
		6	7.3.0 (a)	<p>Annual Report of its associate for the preceding three completed Financial years as on date of Techno Commercial Bid opening to be submitted. As per NIT vide clause no. 7.3.0 (a) , if applicable, a Letter of Undertaking from the Holding Company of its associate, a Certificate from the CEO/CFO of the Holding Company and a Certificate from the CEO/CFO of the bidder to be submitted along with the bid.</p>
		7	7.3.0 (b)	<p>Annual Report of its associate for the last Financial years as on date of Techno Commercial Bid opening to be submitted. As per NIT vide clause no. 7.3.0 (b) , if applicable, Annual Report of of its Subsidiary (ies) and/or Holding Company and/or Subsidiaries of its Holding companies of its (bidder) associate for the last Financial years as on date of Techno Commercial Bid opening to be submitted.</p>
		8	7.2.0 (c) AND 7.3.0 (c)	<p>Annexures, Undertakings and Board Resolutions as mention in 7.2.0 (c) and 7.3.0 (c) also to be submitted, if applicable.</p>

<p>9.0</p>	<p>DOCUMENTS FOR QUALIFYING REQUIREMENTS (QR) {Clause 13.1 of GPC}</p>	<p>Bidders are required to furnish all documents to establish their meeting the Qualifying Requirements stipulated in the Bidding Documents.</p> <p>Bidders are also required to furnish Joint Deed of Undertaking, Associate Agreement, the details of the past experience like authentic Work Orders/Purchase Orders/Letter of Awards/Contract Agreements, client certificates, completion certificate, etc. in support of meeting the Qualifying Requirements based on which selection is to be made as per format at Attachment 7 of Volume I Section IV of the bidding documents. <i>These references shall only be considered to ascertain the bidder's compliance to Qualifying Requirement (QR).</i> No claims without supporting documents shall be accepted in this regard. However, if any of the Work Orders/Purchase Orders/Letter of Awards/Contract Agreements pertains to the work executed by Bidder for NTPC in the past, then in respect of such Work Orders/Purchase Orders/Letter of Awards/Contract Agreements, Bidder shall not be required to enclose Client Certificate along with its Bid.</p> <p>Bidders wishing to provide additional Work Orders/Purchase Orders/Letter of Awards/Contract Agreements are required to declare the same in similar format which shall be additionally attached and uploaded. <i>However, bidders are not permitted to quote more than 3 times the reference works as asked for in the QR.</i></p> <p>During the bid evaluation the Employer may, at its discretion, ask the Bidder for a clarification of its bid including documentary evidence pertaining to only the Work Orders/Purchase Orders/Letter of Awards/Contract Agreements declared in the bid for the purpose of meeting Qualifying Requirement specified in NIT/Bidding Documents. The request for clarification and the response shall be in writing and no change in the price or substance of the bid including substitution of reference plants/Work Orders/Purchase Orders/Letter of Awards/Contract Agreements in the bid by new/additional Work Orders/Purchase Orders/Letter of Awards/Contract Agreements for conforming to Qualifying Requirement shall be sought, offered or permitted.</p> <p>Bidders shall certify their compliance on "Qualifying Requirements" as per Attachment 21 by accepting the following attribute:</p> <p style="padding-left: 40px;">“Do you certify full compliance on Qualifying Requirements?”</p> <p>Acceptance of above attribute shall be considered as bidder's confirmation to the following conditions:</p> <p>(a) The number of reference Works/Orders quoted by Bidder in relevant Annexures and/or attachments of the bid, for establishing compliance to the specified Qualifying Requirement (QR), are in accordance with the provision specified in Special Purchase Conditions (SPC).</p> <p>(b) The reference Works/Orders/declared Orders, shall only be considered</p>

		<p>for evaluation/establishing compliance to Qualifying Requirement (QR). Any reference Orders declared more than as specified in Special Purchase Conditions shall not be considered for evaluation/establishing compliance to Qualifying requirements.</p> <p>(c) <i>No change or substitution in respect of reference Orders for meeting the specified Qualifying Requirement (QR) shall be offered by the bidder.</i></p>
10.0	CUSTOM CLEARANCE	<p>The Contractor shall, at its own expense, handle all imported items (Software, equipment etc.) and Contractor's Software(s) & Equipment at the point(s) of import and shall handle any formalities for customs clearance, including liability for port charges etc., if any. Further, if applicable laws or regulations require any application or act to be made by or in the name of the Employer, the Employer shall take all necessary steps to comply with such laws or regulations. In case of foreign bidders, the Employer shall pay/reimburse the Custom Duty against documentary evidence.</p> <p>In case of foreign bidders, for the purpose of cost comparison, Custom duty including port charges shall be loaded as per the rate applicable on the date of opening of Techno-commercial bid.</p> <p>NTPC shall NOT pay any demurrage, wharfage etc. on account of delay in custom clearance etc.</p> <p>Bidder CHA or their associates shall prepare separate House Airway Bill for each consignment and shall intimate NTPC regarding complete details of the purchase order, AWBs, Flight number and date along with one copy of invoice, packing list by sending a copy of the same in advance through Fax/e-mail as pre-alert.</p> <p>Bidder CHA shall ensure assessment of correct rate of duties as applicable from time to time after taking into account the latest exemption notification etc. if any, as per customs Tariff (including preparing Checklist for Bill of Entry) and obtain concurrence of NTPC before payment of duty for each case. In case of wrong assessment, the responsibility of refund of such customs duty shall lie on the Your CHA. However, excess customs duty shall be borne (recovered) by Bidder.</p> <p>Filing of Bill of Entry and clearance of consignment shall be done within demurrage free period as stipulated from time to time. In case of delay beyond the free period, the demurrage charges for the delayed period shall be borne by the Logistics Agent. However, if the delay is attributable to NTPC due to any specific reason, the demurrage shall be borne by NTPC. In case of any dispute, NTPC reserves the right to decide the quantum of demurrage payable by Bidder.</p>
11.0	COUNTRY OF ORIGIN	<p>For the purpose of these bidding documents, the word facilities means the Items/ Hardware and software to be supplied and installed, together with the services to be carried out by the Contractor/Contractor under the contract. The word "Items/ Hardware and software", "installation</p>

		<p>services”, etc. shall be construed in accordance with the respective definitions given to them.</p> <p>All countries and areas are the eligible source countries for the goods and services to be supplied under this contract and accordingly goods and services to be supplied under this contract may have their origin in any country and area.</p> <p>For purpose of this clause, “Origin” means the place where the goods were mined, grown, or produced, or from which the services are supplied. Goods are produced when, through manufacturing, processing or substantial and major assembly of components, a commercially recognized new product results that is substantially different in basic characteristic or in purpose or utility from its components.</p> <p>The origin of Goods and Services is distinct from the nationality of the Contractor/Contractor.</p> <p>The documentary evidence of the eligibility of the facilities shall consist of a statement on the country of origin of the Items/ Hardware and software offered, which shall be confirmed by a certificate of origin issued at the time of shipment.</p>
<p>12.0</p>	<p>INTELLECTUAL PROPERTY</p>	<p>(i) Copyright</p> <p>The copyright in all drawings, documents and other materials containing data and information furnished to the Employer by the Contractor herein shall remain vested in the Contractor or, if they are furnished to the Employer directly or through the Contractor by any third party, including Contractors of materials, the copyright in such materials shall remain vested in such third party. The Employer shall however be free to reproduce all drawings, documents and other material furnished to the Employer for the purpose of the contract including, if required, for operation and maintenance of the facilities.</p> <p>(ii) Confidential Information</p> <p>a) The Employer and the Contractor shall keep confidential and shall not, without the written consent of the other party hereto, divulge to any third party any documents, data or other information furnished directly or indirectly by the other party hereto in connection with the Contract, whether such information has been furnished prior to, during or following termination of the Contract. Notwithstanding the above, the Contractor may furnish to its Sub-Contractor(s) such documents, data and other information it receives from the Employer to the extent required for the Sub-Contractor(s) to perform its work under the Contract, in which event the Contractor shall obtain from such Sub-Contractor(s) an undertaking of confidentiality similar to that imposed on the Contractor under this SPC Clause 12.0 (ii).</p>

		<p>b) The Employer shall not use such documents, data and other information received from the Contractor for any purpose other than execution of the Contract and operation and maintenance of the Facilities. Similarly, the Contractor shall not use such documents, data and other information received from the Employer for any purpose other than the design, procurement of Software and Items/ Hardware or such other work and services as are required for the performance of the Contract.</p> <p>c) The obligation of a party under SPC Sub-Clauses Clause 12.0 (ii) (a) and (b) above, however, shall not apply to that information which</p> <p>(a) now or hereafter enters the public domain through no fault of that party</p> <p>(b) can be proven to have been possessed by that party at the time of disclosure and which was not previously obtained, directly or indirectly, from the other party hereto</p> <p>(c) Otherwise lawfully becomes available to that party from a third party that has no obligation of confidentiality.</p> <p>(d) The above provisions of this Clause 12.0 (ii) shall not in any way modify any undertaking of confidentiality given by either of the parties hereto prior to the date of the Contract in respect of the Facilities or any part thereof.</p> <p>(iii) The provisions of this Clause 12.0 (ii) shall survive termination, for whatever reason, of the Contract</p>
13.0	PROJECT MANAGER/ENGR-IN-CHARGE	<p>a) If the Project Manager is not named in the Contract, then within fourteen (14) days of the Effective Date, the Employer shall appoint and notify the Contractor in writing of the name of the Project Manager. The Employer may from time to time appoint some other person as the Project Manager in place of the person previously so appointed, and shall give a notice of the name of such other person to the Contractor without delay. The Employer shall take reasonable care to see that no such appointment is made at such a time or in such a manner as to impede the progress of work on the Facilities. The Project Manager shall represent and act for the Employer at all times during the currency of the Contract. All notices, instructions, orders, certificates, approvals and all other communications under the Contract shall be given by the Project Manager, except as herein otherwise provided.</p> <p>b) All notices, instructions, information and other communications given by the Contractor to the Employer under the Contract shall be given to the Project Manager, except as herein otherwise provided.</p>
14.0	CONTRACTOR'S REPRESENTATIVE	<p>(i) If the Contractor's Representative is not named in the Contract, then within fourteen (14) days of the Effective Date, the Contractor shall appoint the Contractor's Representative and shall request the</p>

		<p>Employer in writing to approve the person so appointed. If the Employer makes no objection to the appointment within fourteen (14) days, the Contractor's Representative shall be deemed to have been approved. If the Employer objects to the appointment within fourteen (14) days giving the reason therefore, then the Contractor shall appoint a replacement within fourteen (14) days of such objection.</p> <p>(ii) The Contractor's Representative shall represent and act for the Contractor at all times during the currency of the Contract and shall give to the Project Manager all the Contractor's notices, instructions, information and all other communications under the Contract.</p> <p>(iii) All notices, instructions, information and all other communications given by the Employer or the Project Manager to the Contractor under the Contract shall be given to the Contractor's Representative or, in its absence, its deputy, except as herein otherwise provided.</p> <p>(iv) The Contractor shall not revoke the appointment of the Contractor's Representative without the Employer's prior written consent, which shall not be unreasonably withheld. If the Employer consents thereto, the Contractor shall appoint some other person as the Contractor's Representative, pursuant to the procedure set out in SPC Sub-Clause 14.0 (i).</p> <p>(v) The Contractor's Representative may, subject to the approval of the Employer (which shall not be unreasonably withheld), at any time delegate to any person any of the powers, functions and authorities vested in him or her. Any such delegation may be revoked at any time. Any such delegation or revocation shall be subject to a prior notice signed by the Contractor's Representative, and shall specify the powers, functions and authorities thereby delegated or revoked. No such delegation or revocation shall take effect unless and until a copy thereof has been delivered to the Employer and the Project Manager.</p> <p>Any act or exercise by any person of powers, functions and authorities so delegated to him or her shall be deemed to be an act or exercise by the Contractor's Representative.</p> <p>Notwithstanding anything stated in SPC Sub-clause 14.0 (i) and 14.0 (ii) above, for the purpose of execution of contract, the Employer and the Contractor shall finalise and agree to a Contract Co-ordination Procedure and all the communication under the Contract shall be in accordance with such Contract Co-ordination Procedure.</p>
<p>15.0</p>	<p>CONTRACTOR'S ORGANIZATION</p>	<p>The Contractor shall supply to the Employer and the Project Manager a chart showing the proposed organization to be established by the Contractor for carrying out work on the Facilities. The chart shall include the identities of the key personnel together with the curricula vitae of such key personnel to be employed within twenty-one (21) days of the Effective Date. The Contractor shall promptly inform the Employer and the Project</p>

		Manager in writing of any revision or alteration of such an organization chart.
16.0	PROGRAM OF PERFORMANCE	Within fourteen days (14) days after the date of Notification of Award of Contract, the Contractor shall prepare and submit to the Project Manager a detailed program of performance of the Contract showing the sequence in which it proposes to execute the contract & achieve the deliverables at site as well as the date(s) by which the Contractor reasonably requires that the Employer shall have fulfilled its obligations under the Contract so as to enable the Contractor to execute the Contract in accordance with the program and to achieve Completion and Acceptance of the Facilities in accordance with the Contract. The program so submitted by the Contractor shall be in accordance with the Time Schedule as per clause 7.0 (Work Schedule) of Volume III - Technical Specification & Scope of Work. The Contractor shall update and revise the program as and when appropriate or when required by the Project Manager, but without modification in the Times for Completion.
17.0	PROGRESS REPORT	<p>The Contractor shall monitor progress of all the activities specified in the program referred to in SCC Sub-Clause 16.0 (Program of Performance) above, and supply a progress report to the Project Manager every month.</p> <p>The progress report shall be in a form acceptable to the Project Manager and shall also indicate: (a) percentage completion achieved compared with the planned percentage completion for each activity; and (b) where any activity is behind the program, giving comments and likely consequences and stating the corrective action being taken.</p>
18.0	PROGRESS OF PERFORMANCE	If at any time the Contractor's actual progress falls behind the program referred to in SPC Sub-Clause 16.0 (Program of Performance), or it becomes apparent that it will so fall behind, the Contractor shall, at the request of the Employer or the Project Manager, prepare and submit to the Project Manager a revised program, taking into account the prevailing circumstances, and shall notify the Project Manager of the steps being taken to expedite progress so as to attain Completion of the Facilities within the Time for Completion.
19.0	APPROVAL/REVIEW OF TECHNICAL DOCUMENTS BY PROJECT MANAGER	<p>The Contractor shall prepare (or cause its Sub-contractors to prepare) and furnish to the Project Manager the relevant, drawings, technical data sheets etc. for approval and/or review.</p> <p>Any part of the Items/ Hardware and Software etc. covered by or related to the documents to be approved by the Project Manager shall be executed only after the Project Manager's approval thereof.</p> <p>Within twenty-one (21) days after receipt by the Project Manager of any document requiring the Project Manager's approval, the Project Manager shall either return one copy thereof to the Contractor with its approval endorsed thereon or shall notify the Contractor in writing of its disapproval thereof and the reasons therefore and the modifications that the Project Manager proposes.</p>

		<p>The Project Manager shall not disapprove any document, except on the grounds that the document does not comply with some specified provision of the Contract or that it is contrary to good engineering practice.</p> <p>If the Project Manager disapproves the document, the Contractor shall modify the document and resubmit it for the Project Manager's approval. If the Project Manager approves the document subject to modification(s), the Contractor shall make the required modification(s), and upon resubmission with the required modifications the document shall be deemed to have been approved.</p> <p>The procedure for submission of the documents by the Contractor and their approval by the Project Manager shall be discussed and finalised with the Contractor.</p> <p>The Project Manager's approval, with or without modification of the document furnished by the Contractor, shall not relieve the Contractor of any responsibility or liability imposed upon it by any provisions of the Contract except to the extent that any subsequent failure results from modifications required by the Project Manager.</p> <p>The Contractor shall not depart from any approved document unless the Contractor has first submitted to the Project Manager an amended document and obtained the Project Manager's approval thereof.</p>
<p>20.0</p>	<p>INSTALLATION</p>	<p>The Contractor shall give or provide all necessary superintendence during the installation of the Hardware and Softwares, and the Contractors Representative or its deputy shall be constantly on the Site to provide full-time superintendence of the installation. The Contractor shall provide and employ only technical personnel who are skilled and experienced in their respective callings and supervisory staff who are competent to adequately supervise the work at hand.</p>
<p>21.0</p>	<p>LABOUR/PERSONNEL/ PROFESSIONAL</p>	<p>(a) The Contractor shall provide and employ on the Site in the installation of the Facilities such skilled, semi-skilled and unskilled labor Personnel/ Professional as is necessary for the proper and timely execution of the Contract. The Contractor is encouraged to use local labor that has the necessary skills.</p> <p>(b) Unless otherwise provided in the Contract, the Contractor shall be responsible for the recruitment, transportation, accommodation and catering of all labor Personnel/ Professional, local or expatriate, required for the execution of the Contract and for all payments in connection therewith.</p> <p>(c) The Contractor shall be responsible for obtaining all necessary permit(s) and/or visa(s) from the appropriate authorities for the entry of all labor, professional and personnel to be employed on the Site into the country where the Site is located.</p> <p>(d) The Contractor shall at its own expense provide the means of repatriation to all of its and its Sub-contractor's personnel employed</p>

		<p>on the Contract at the Site to their various home countries. It shall also provide suitable temporary maintenance of all such persons from the cessation of their employment on the Contract to the date programmed for their departure. In the event that the Contractor defaults in providing such means of transportation and temporary maintenance, the Employer may provide the same to such personnel and recover the cost of doing so from the Contractor.</p> <p>(e) The Contractor shall at all times during the progress of the Contract use its best endeavors to prevent any unlawful, riotous or disorderly conduct or behavior by or amongst its employees and the labor of its Sub-contractors.</p> <p>(f) The Contractor shall, in all dealings with its labor and the labor of its Sub-contractors currently employed on or connected with the Contract, pay due regard to all recognized festivals, official holidays, religious or other customs and all local laws and regulations pertaining to the employment of labor</p>
22.0	LABOUR LAWS AND REGULATIONS AND COMPLIANCE THEREOF	<p>For the labour deployed during the entire period of Contract, the Contractor shall, at all times abide by all applicable labour enactments, rules made therein, regulations, notifications and bye-laws by the appropriate government, local authority or any other labour laws or notification that may be issued under any labour law, published by the State or Central Government or Local Authorities like EPF & MP Act, 1952; ESI Act, 1948; Minimum Wages Act, 1948; Payment of Wages Act, 1936; Payment of Bonus Act, 1965; Payment of Gratuity Act, 1972; Workmen's Compensation Act, 1923; Fatal Accidents Act, 1855 etc. This list is not in any way exhaustive and shall not absolve the Contractor/sub-contractor from any of his liabilities or responsibilities in compliance with any other laws, regulations, notifications that may be in force during the tenure of Contract. The employees of the Contractor/ sub-contractor shall in no case be treated as the employees of the Employer at any point of time.</p>
23.0	CONTRACTOR'S EQUIPMENT	<p>(i) All Contractors' Equipment brought by the Contractor onto the Site shall be deemed to be intended to be used exclusively for the execution of the Contract. The Contractor shall not remove the same from the Site without the Project Manager's consent that such Contractor's Equipment is no longer required for the execution of the Contract.</p> <p>(ii) Unless otherwise specified in the Contract, upon completion of the Facilities, the Contractor shall remove from the Site all Equipment brought by the Contractor onto the Site and any surplus materials remaining thereon.</p>
24.0	SAFETY	<p>The Contractor, while executing the Works, will strictly comply with the statutory requirements (including amendments thereof), as applicable, in respect of safety of his employees, Items/ Hardware and software and materials. The Contractor will also comply with the provisions of NTPC Safety Rules as issued from time to time and displayed on NTPC's tender</p>

		website http://www.ntpctender.com																
25.0	BID PRICES	<p>Bidders shall quote for the entire scope on a “single responsibility” basis, such that the total bid price (per Unit) covers all the Contractor’s obligations mentioned in or to be reasonably inferred from the bidding documents in respect of the design, manufacture, including procurement and subcontracting (if any), delivery.</p> <p>Bidders are required to quote the price (per Unit) for the commercial, contractual and technical obligations outlined in the bidding documents.</p> <p>Following schedules are to be filled up (per Unit):</p> <table border="1"> <tr> <td>Schedule-1</td> <td>Items/ Hardware and software to be supplied from Abroad (per Unit).</td> </tr> <tr> <td>Schedule-2</td> <td>Items/ Hardware and software to be supplied from within the Employer's Country (per Unit).</td> </tr> <tr> <td>Schedule-3</td> <td>Local Transportation including Port handling, Port clearance, Port charges, Inland insurance and other local costs incidental to delivery of Items/ Hardware and software (per Unit).</td> </tr> <tr> <td>Schedule-4</td> <td>Installation Services, Training , Handholding and Tuning services ,SAT, Insurance covers other than inland transit insurance and other services as specified in the bidding documents (per Unit).</td> </tr> <tr> <td>Schedule-5</td> <td>Not applicable</td> </tr> <tr> <td>Schedule -6</td> <td>Taxes and Duties, applicable on Ex-works (India) price component (Schedule-2), not included in bid price (per Unit).</td> </tr> <tr> <td>Schedule -7</td> <td>Break up of different taxes including GST included in the price quoted in schedule 3 & 4 against different items (per Unit).</td> </tr> <tr> <td>Schedule -8</td> <td>The details of supply of Item/Equipment and Mandatory Spares and services which are under Reverse Charge Mechanism as per GST act and included in schedule 1,2,3 &4 (per Unit).</td> </tr> </table> <p>In the Schedules, Bidders shall give the required details and a breakdown of their prices (per Unit) as follows:</p> <p>i. Schedule No. 1 Items/ Hardware and software to be supplied from Abroad (per Unit) Schedule No.1 items shall be quoted on CIF (Indian port-of-entry)</p>	Schedule-1	Items/ Hardware and software to be supplied from Abroad (per Unit).	Schedule-2	Items/ Hardware and software to be supplied from within the Employer's Country (per Unit).	Schedule-3	Local Transportation including Port handling, Port clearance, Port charges, Inland insurance and other local costs incidental to delivery of Items/ Hardware and software (per Unit).	Schedule-4	Installation Services, Training , Handholding and Tuning services ,SAT, Insurance covers other than inland transit insurance and other services as specified in the bidding documents (per Unit).	Schedule-5	Not applicable	Schedule -6	Taxes and Duties, applicable on Ex-works (India) price component (Schedule-2), not included in bid price (per Unit).	Schedule -7	Break up of different taxes including GST included in the price quoted in schedule 3 & 4 against different items (per Unit).	Schedule -8	The details of supply of Item/Equipment and Mandatory Spares and services which are under Reverse Charge Mechanism as per GST act and included in schedule 1,2,3 &4 (per Unit).
Schedule-1	Items/ Hardware and software to be supplied from Abroad (per Unit).																	
Schedule-2	Items/ Hardware and software to be supplied from within the Employer's Country (per Unit).																	
Schedule-3	Local Transportation including Port handling, Port clearance, Port charges, Inland insurance and other local costs incidental to delivery of Items/ Hardware and software (per Unit).																	
Schedule-4	Installation Services, Training , Handholding and Tuning services ,SAT, Insurance covers other than inland transit insurance and other services as specified in the bidding documents (per Unit).																	
Schedule-5	Not applicable																	
Schedule -6	Taxes and Duties, applicable on Ex-works (India) price component (Schedule-2), not included in bid price (per Unit).																	
Schedule -7	Break up of different taxes including GST included in the price quoted in schedule 3 & 4 against different items (per Unit).																	
Schedule -8	The details of supply of Item/Equipment and Mandatory Spares and services which are under Reverse Charge Mechanism as per GST act and included in schedule 1,2,3 &4 (per Unit).																	

		<p>basis.</p> <p>Further, Bidders seeking qualification on the basis of association with manufacturer(s) of particular Items/ Hardware and software (s) are required to quote the price of such Items/ Hardware and software (s) including spares on CIF (Indian port-of-entry) basis, if the items are to be imported by the manufacturer or the bidder. In case, such Items/Hardware and software and spares are not quoted by the bidder on CIF (Indian port-of-entry) basis, then EMPLOYER shall assess the CIF (Indian port-of-entry) price of such Items/ Hardware and software for the purpose of evaluation.</p> <p>Notwithstanding GPC Sub 58.0, the Employer shall bear and promptly pay custom duty as well as GST on Imports and any other tax/duty/levy, imposed on the Item/Equipment and Mandatory Spares specified in Price Schedule No. 1 (and on recommendatory spares part to be supplied from abroad and specified in Schedule No. 5, when awarded) and that are to be incorporated into the Facilities by the law of the country where the Site is located. Further, the Bidder is advised to source the Item/Equipment and Mandatory Spares including Mandatory Spares/ Recommended Spares from territories which do not attract additional duties under Customs like Anti-dumping duty (Section 9A to Custom Tariff Act), Counter-vailing duty on subsidised articles (Section 9 to Custom Tariff Act), Safeguard duty (Section 8A, 8B, 8C to Custom Tariff Act) etc. In case any such additional duties under Customs is imposed on Item/Equipment and Mandatory Spares including Mandatory Spares/ Recommended Spares, the same shall be borne and paid/reimbursed by the Bidder.</p> <p>However, if the local laws require such payment of the custom duty or GST to be made by the Bidder, the same shall be reimbursed to the Bidder on production of satisfactory evidence of having paid the custom duty or GST amount to the concerned authorities</p> <p>ii. Schedule No. 2: Items/ Hardware and software to be supplied from within the Employer's Country (per Unit)</p> <p>Schedule No. 2 items shall be quoted on EXW (exfactory, ex-works, ex-warehouse or off- the-shelf, as applicable) basis and shall be inclusive of all costs as well as taxes, duties and levies (including GST considering ITC benefit) paid or payable on components and raw materials incorporated or to be incorporated in the facilities.</p> <p>Further, the prices for Mandatory Spares shall be quoted in compliance with the requirements as per the list of Mandatory Spares specified in the Technical Specifications and the Price Schedule-2 of the Bidding documents.</p> <p>However, GST and any other tax/duty/levy applicable in respect of direct transactions between the Employer and the Bidder/ Assignee of Foreign Bidder (if applicable) and on Bought out Items (to be</p>
--	--	--

		<p>dispatched directly from the subvendor's works to Project Site) shall not be included in the Ex-Works price, but shall be quoted separately in Schedule No. 6.</p> <p>GST and other applicable tax/duty/levy quoted by the bidder in Schedule No. 6 shall be as applicable in the Employer's country as on seven (7) days prior to the deadline for submission of Price Bids.</p> <p>The Employer shall also bear and pay/reimburse to the Bidder /Assignee of Foreign Bidder (if applicable) GST and any other tax/duty/levy in respect of both direct transactions between the Employer and the Bidder /Assignee of Foreign Bidder (if applicable) and on Bought out items (to be dispatched directly from the subvendor's works to Project Site), if imposed on the Items and Mandatory Spares specified in Price Schedule No. 2 (and also on locally supplied recommendatory Spares quoted in Schedule No. 5, when awarded) to be incorporated in the Package, by the law of country where the Site is located.</p> <p>Due Input Tax credits under GST as per the relevant Govt. Policy, wherever applicable, shall be taken into account by the Bidder while quoting his prices.</p> <p>iii. Schedule No. 3: Local Transportation including Port handling, Port clearance, Port charges, Inland insurance and other local costs incidental to delivery of Items/ Hardware and software (per Unit).</p> <p>Local Transportation including Port handling, Port clearance, Port charges, Inland insurance and other local costs incidental to delivery of Items/ Hardware and software. Local Transportation, Inland Transit Insurance, Port Clearance, Port Handling and Port Charges, Custom reconciliation and other local costs incidental to delivery of the Items/ Hardware and software shall be quoted in Schedule-3 inclusive of all taxes / duties / levies & charges including GST, if any for supply of such services payable in the Employer's country as on 7 days prior to the deadline for submission of Price Bid. The Employer shall be responsible and be liable only for payment of Customs Duty and GST and any other tax/duty/levy on Imports on CIF (Indian Port of Entry) component of the Items/Hardware and software to be supplied from abroad quoted in Schedule No. 1. However, the Employer, as a consignee shall furnish promptly necessary clarifications and documents as may be required to be furnished by the consignee for the purpose of customs clearance.</p> <p>Notwithstanding anything stated above, in case of services covered under Reverse Charge Mechanism, bidder shall quote only basic price for said service and for evaluation the bid of Supplier of Services shall be cost compensated as per the GST rate applicable as per GST Law.</p> <p>Due Input Tax credits under GST as per the relevant Govt. Policy, wherever applicable, shall be taken into account by the Bidder while</p>
--	--	--

		<p>quoting his prices.</p> <p>iv. Schedule No. 4: Installation Services, Training, Handholding and Tuning services, SAT, Insurance covers other than inland transit insurance and other services as specified in the bidding documents (per Unit).</p> <p>Installation Services including Erection and Civil & Allied Works (as applicable) shall be quoted separately (Schedule No. 4) and shall include rates or prices for all labour, Bidder's equipment, temporary works, materials, consumables and all matters and things of whatsoever nature, charges for insurance covers other than inland transit Insurance including operations and maintenance services, the provision of operations and maintenance manuals, training of employer's personnel, etc., and other supply of services, as identified in the Bidding Documents, as necessary for the proper execution/supply of the Installation Services. The prices quoted in Schedule No. 4 shall be inclusive of all Taxes, Duties, Levies and Charges including GST payable in the Employer's country as of seven (7) days prior to the deadline for submission of Price Bids. Accordingly, all Taxes, Duties, Levies & Charges including GST on the Materials incorporated in Civil & Allied Works (as applicable) shall also be included in the prices quoted in Schedule No. 4 & no Separate payment on this account, whatsoever, shall be made by Employer.</p> <p>Notwithstanding anything stated above, in case of services covered under Reverse Charge Mechanism, bidder shall quote only basic price for said service and for evaluation the bid of Supplier of Services shall be cost compensated as per the GST rate applicable as per GST Law.</p> <p>Due Input Tax credits under GST as per the relevant Govt. Policy, wherever applicable, shall be taken into account by the Bidder while quoting his prices.</p> <p>v. Schedule No. 5: Not Applicable</p> <p>vi. Schedule No. 6: Taxes and Duties, applicable on Ex-works (India) price component (Schedule-2), not included in bid price (per Unit).</p> <p>vii. Schedule No. 7: Break up of different taxes including GST included in the price quoted in schedule 3 & 4 against different items (per Unit).</p> <p>viii. Schedule No. 8: The details of supply of Item/Equipment and Mandatory Spares and services which are under Reverse Charge Mechanism as per GST act and included in schedule 1,2,3 & 4 (per Unit).</p> <p>In case RCM is applicable on any Service and the Service with value has not been specified by the Bidder in Schedule 8, RCM paid by Employer shall be to Bidders account.</p>
--	--	---

		<p>Bidders shall note that the Items/ Hardware and software included in Schedule No.1 and 2 above shall exclude all materials used in civil, building and other construction works, if any. All such materials shall be included and priced under Schedule No.4 (Installation Services).</p> <p>The terms EXW, FOB, CIF, etc., shall be governed by the rules prescribed in the current edition of Incoterms, published by the International Chamber of Commerce, 38, Cours Albert 1er, 75008, Paris, France.</p> <p>Price Bid should not contain any matter in respect of Technical and / or Commercial aspects other than the details specifically sought in the Price Bid. If the Technical/commercial matters indicated in Price Bid are found to be in contradiction with the details furnished in Techno-Commercial Bid, the details furnished in Techno-Commercial Bid shall prevail.</p> <p>The Price Bid submitted by the Bidder shall comprise of the following:</p> <p>Bidders shall give a breakdown of the prices in the manner and detail called for in the Price Schedules.</p> <p>The Attachments (1P and 2P) and the price schedules shall be uploaded in General Data through 'Attachment' link provided in "Unpriced Bid" tab. (Bidders may note that the attachment (1P and 2P) and price schedule should not be uploaded in C Folder)</p> <p>The total amount of each of the schedule (Schedule 1 to Schedule 4 and Schedule 6) shall be filled up in Basic Price Conditions field of the items for respective item specified in Item data of Main Screen of Bid Invitation. The total bid price(s) (per Unit) (i,e, summation of Schedule 1 to Schedule 4 and Schedule 6) is automatically computed which can be viewed by the Bidder through Output Preview tab in Main Screen of Bid Invitation.</p> <p>In case of discrepancy between unit price and total price of schedules (excel files), the unit price will be considered as correct.</p> <p>In case of discrepancy between unit price and total price, which is obtained by multiplying the unit price and quantity, or between sub-totals and the total price, the unit or subtotal price shall prevail, and the total price shall be corrected accordingly.</p> <p>The prices in excel file shall prevail the prices in On line BPS.</p> <p>Bidders must quote the break up of rate of taxes & duties. In case bidder has indicated (Zero/blank) taxes & duties in the online BPS and Price Schedule (excel files) same shall be treated as included in the price. In such case, Bidders must indicate the rate of tax in the proposal. In case rate of tax included in the price is not given by the bidder, no variation shall be payable.</p> <p>Bidders may note that NTPC shall not be issuing any concessional Sales tax form.</p>
--	--	--

<p>26.0</p>	<p>INDIAN AGENT</p>	<p>If a foreign bidder has engaged an Indian agent, it will be required to give the following details in its bid as per the format enclosed in the Bidding Documents.</p> <ul style="list-style-type: none"> (a) The name and address of the local agent; (b) What Service the agent renders; and (c) The fixed amount of remuneration for the agent included in the offer; <p>The agency commission shall be indicated in the space provided for in the Price Schedule and will be paid to the bidder's agent in India in Indian Rupees using the Telegraphic Transfer Buying Market rate of exchange ruling on the date of Notification of Award and shall not be subject to any escalation or any further exchange variation, whatsoever and will be payable pro-rata along with the base contract price payment.</p> <p>The above details shall be provided in Attachment 1P.</p>
<p>27.0</p>	<p>BOUGHT ITEMS</p>	<p>Details of bought-out items to be directly despatched by sub-vendor(s) along with its value/price as per Employer's format as Attachment 2P.</p>
<p>28.0</p>	<p>BID CURRENCIES</p>	<p>Prices shall be quoted in the following currencies:</p> <ul style="list-style-type: none"> (a) Items/ Hardware and software covered in Schedule 1 shall be quoted in any currency. Domestic Bidders while quoting in foreign currency must comply with the requirement as laid down by Govt. of India from time to time. (b) Schedule 2 and EXW/CIF price of recommended spare parts covered in Schedule 5 shall be quoted in local currency. (c) Local transportation, inland transit insurance and other local costs incidental to delivery of the Items/ Hardware and software covered in Schedule 3 and Installation services covered under Schedule 4 shall be quoted in local currency. However, foreign component, if any, of Installation Services covered under Schedule 4 may be quoted in foreign currency. (d) Local Transportation, inland transit insurance and other local costs incidental to delivery of recommended spares covered under Schedule 5 shall be quoted in Local Currency. (e) If the Bidder wishes to be paid in a combination of amounts in different currencies, it may quote its price accordingly, but use no more than three foreign currencies. (f) The foreign currencies in which the bid prices are quoted shall be freely convertible.
<p>29.0</p>	<p>GUARANTEE DECLARATION</p>	<p>Not Applicable</p>

30.0	LIQUIDATED DAMAGES	The provisions of Clause 50.0 of GPC may be read as under
30.1	FOR SUPPLY, INSTALLATION, COMMISSIONING AND TRAINING	<p>The timely execution is the essence of the contract. In the event of supplier's failure to deliver the material (Hardware & Software) of acceptable quality within the stipulated period, the liquidated damages are payable by the contractor @ 0.5% (one half of one percent) per week of delay or part thereof, of the unexecuted total awarded package value excluding AMC.</p> <p>LD shall be applicable only at the end of the project completion period of 18 months as per standard terms and conditions and no LD shall be imposed for phase wise implementation. (For the purpose of imposition of LD, phase wise work schedule given in Clause 7.0 (Work Schedule) of Technical specifications shall not be considered.)</p> <p>However, the total liability of the Bidder under this clause shall not exceed 5% of the Contract value as awarded excluding AMC.</p>
31.0	CONTRACT PERIOD {Clause 36.0 of GPC}	Five (05) years from date of award as detailed below, subject to completion of SAT for all four units within 12 months from the issuing of date of Purchase Order. In case of delay in completion of SAT, contract period would be extended accordingly.
31.1	SAT (SITE ACCEPTANCE TESTING) FOR PERFORMANCE TESTING {Clause 36.0 of GPC}	As per clause 7.0 (work schedule) of Volume III - Technical Specification & Scope of Work, commissioning and SAT for performance testing of all four units shall be completed within 12 months from the issuing of date of Purchase Order .
31.2	WARRANTY PERIOD	As per provisions stated at clause 11.0 of Volume III - Technical Specification & Scope of Work, the Warranty Period for Comprehensive warranty of complete APC system (hardware & software) shall be one(1) year from the completion of the SAT.
31.3	COMPREHENSIVE ON-SITE HARDWARE/SOFTWARE ANNUAL MAINTENANCE CONTRACT (AMC)	As per provisions stated at clause 11.0 of Volume III - Technical Specification & Scope of Work, the Comprehensive on-site hardware/software Annual Maintenance Contract (AMC) Period shall be three(3) years after the completion of comprehensive warranty period.
31.0 (b)	CONTINUOUS PERFORMANCE TEST	As per clause 9.0 of Volume III - Technical specifications and scope of work.

31.0 (a)	TRAINING	As per clause 12.0 of Volume III - Technical specifications and scope of work.
32.0	CONTRACT PERFORMANCE GUARANTEE (CPG) FOR SUPPLY, SAT & WARRANTY {Clause 39.0 of GPC}	<p>The successful bidder/Supplier shall furnish the Contract Performance Guarantee for due performance of the Contracts for an amount equal to 10% of total awarded package value. CPG should be valid for a period of three months (3 months) beyond the expiry of defect liability/warranty period.</p> <p>However, that if the Contractor, pursuant to Clause 36.0 & 60.0 of SPC, is liable for an extended warranty obligation, the CPGs shall be extended for the period.</p> <p>The CPG should be submitted within 30 days of placement of award. This CPG for 10% shall be released only after receipt and acceptance of CPG for AMC period.</p> <p>If the Employer accepts to enters into 'Second Contract' and/or 'Third Contract' with the Assignee of a foreign Bidder, pursuant to SPC Sub-Clause 55.0, the said Assignee, in addition to the CPG to be provided by the foreign Bidder for ten percent (10%) of the value of all the Contracts i.e. First Contract, Second Contract and Third Contract, shall provide within 30 days of the placement of award, separate CPG equivalent to ten percent (10%) of the value of Contract(s) entered into with the Assignee, for the due performance of Contract, with a initial validity upto three months (3 months) beyond the expiry of defect liability/warranty period. However, in case of delay in completion of the defect liability period, the validity of all the contract performance securities shall be extended by the period of such delay.</p> <p>The CPG can be given in any of forms mentioned at clause 39.0 of GPC.</p>
32.1	CONTRACT PERFORMANCE GUARANTEE (CPG) FOR AMC	<p>The successful bidder shall be required to furnish a CPG equivalent to 5% of the total awarded package value valid for 3 months beyond the AMC period of three(3) years after the completion of comprehensive warranty period.</p> <p>However, that if the Contractor, pursuant to Clause 36.0 & 60.0 of SPC, is liable for an extended warranty obligation, the CPG shall be extended for the period.</p> <p>This CPG shall be furnished 15 days before the expiry of warranty period. However, in CPG is submitted by way of BG, the BG to be initially valid for three years and thereafter to be extended suitably to cover the remaining contract period. In case extension is not received well before the lapse of BG, the BG submitted shall be liable for encashment.</p> <p>Further, in case the Supplier fails to submit CPG for AMC period within the time line specified above, the CPG furnished towards warranty period may</p>

		<p>be forfeited.</p> <p>If the Employer accepts to enters into Third Contract' with the Assignee of a foreign Bidder, pursuant to SPC Sub-Clause 57.0, the said Assignee, in addition to the CPG to be provided by the foreign Bidder for five percent (5%) of the total awarded package value valid for 3 months beyond the AMC period of six (06) years after warranty period, shall provide within 30 days of the placement of award, separate CPG equivalent to five percent (5%) of the value of Contract(s) entered into with the Assignee valid for 3 months beyond the AMC period of six (06) years after warranty period entered into with the Assignee, for the due performance of Contract. However, in case of delay in completion of the Comprehensive On-Site Hardware/Software Annual Maintenance Contract (AMC) period, the validity of all the contract performance securities shall be extended by the period of such delay.</p> <p>The CPG can be given in any of forms mentioned at clause 39.0 of GPC.</p>
32.2		<p>The bank guarantee submitted from within India towards Contract Performance Security and Security for Deed of Joint Undertaking (if applicable) shall be issued on a stamp paper of appropriate value as per stamp act prevailing in the State of the issuing Bank in India or the state of U.P. in India or the State from where the BG shall be operated, whichever is higher.</p> <p>In case of guarantees issued by branches outside India for foreign banks, the bank guarantees shall be routed through the correspondent Bank in India for due verification of signatures of the executants. The BG issued by a Bank outside India also needs to bear Stamp Duty of appropriate value applicable to the place in NTPC where BG is to be submitted, the BG will be adjudicated from Collector of Stamps, within 3 months of arrival of BG in India and the expenses incurred in this regard shall be recovered from the Contractor.</p>
32.03	BANK GUARANTEE TO BE FURNISHED BY THE ASSOCIATE	<p>In case of award, the Associate will be required to furnish an on demand Bank Guarantee for 5%(five percent) of the total contract price in addition to the Contract Performance Security to be furnished by the bidder. Such Bank Guarantee shall remain in force upto and including the ninety (90) days after the end of the Annual Maintenance Contract (AMC) Period of three(3) years after the completion of comprehensive warranty period as specified in contract.</p>
33.0	PRICE BASIS	<p>The bidders are required to quote prices on FIRM price basis.</p>
34.0	INSURANCE {Clause 41.0 of GPC}	<p>Under the contract, the Contractor shall be responsible for the loss or damage to the Items/ Hardware and software until the package is finally commissioned and taking over. The Contractor shall take necessary insurance cover and include the insurance charges in the prices quoted.</p>

<p>35.0</p>	<p>FREIGHT {Clause 42.0 of GPC}</p>	<p>The material is to be supplied directly to site located at location specified in the Technical Specifications.</p> <p>Bidder shall be responsible for transportation and safe delivery of material.</p>
<p>36.0</p>	<p>WARRANTY & AMC {Clause 45.0 of GPC}</p>	<p>As per clause 11.0 of Volume III - Technical Specification & Scope of Work, Warranty for One Year and AMC for 03 years.</p> <p>However, if the Bidder fail to depute adequate experienced personnel as and when required during the warranty period to ensure 99% system availability, the Comprehensive warranty Period of the Facilities, shall be extended by a period equal to the period during which the Facilities cannot ensure 99% system availability</p> <p>AND</p> <p>If the Bidder fail to ensure 99% availability of the system with AMC, the Comprehensive on-site hardware/software Annual Maintenance Contract (AMC) Period of the Facilities, shall be extended by a period equal to the period during which the Facilities cannot ensure 99% system availability.</p>
<p>37.0</p>	<p>TAXES & DUTIES {Clause 59.0 (i) of GPC}</p>	<p>The clause may be read as under:</p> <ol style="list-style-type: none"> i. "Goods and Services Tax" or "GST" means taxes or cess levied under the Central Goods and Services Tax Act, Integrated Goods and Services Tax Act, Goods and Services Tax (Compensation to States) Act and various State/Union Territory Goods and Services Tax Laws and applicable cesses, if any under the laws in force (hereinafter referred to as relevant GST Laws), which shall be fully complied with by the Bidder. ii. The Bidder shall quote the prices giving breakup in the manner specified in the Price Schedule. The Bidder shall quote the applicable rate of GST in the Price Schedule. iii. For the purpose of Evaluation, GST quoted in the Bid shall only be considered. iv. The Bidder shall indicate the taxes and duties as applicable seven (7) days prior to last date of Bid Submission. v. The Bidder is required to quote the rate of GST applicable under GST Law in the Price Schedule while giving the breakup of prices. vi. In case GST registered Bidder has quoted GST rate as '0' (Zero), the quoted price shall be considered to be inclusive of GST as applicable. vii. In case of bid received from dealers who have opted for the composition scheme under GST Law, the Bidder shall specifically mention the same in his Bid. Owner shall not be liable to pay/reimburse any GST on the supplies made by such dealers under

		<p>the Order/Contract.</p> <p>viii. In case of bid received from unregistered dealer, for evaluation their bid shall be cost compensated as per the GST rate applicable in view of Reverse Charge Mechanism (RCM) as per GST Law.</p> <p>ix. In case of all materials identified by the Supplier and Owner to be dispatched directly from the sub-vendor's work to Owner's site, the Supplier shall ensure that his sub-vendors raise Tax invoices as per the provisions of GST Law, billed to the Supplier and shipped to the Owner's site. The Supplier shall further ensure that he raises his corresponding Tax Invoices in the name of Owner during transit of the materials before the delivery of materials is taken by Owner.</p> <p>x. Notwithstanding anything to contrary contained in the Purchase Order/Contract, the Supplier's right to payment under the Order/Contract is subject to issuance of valid tax invoice/bill of supply as the case may be, payment of applicable GST to the credit of appropriate Government and submission of valid particulars of tax invoice under GST returns in accordance with GST Law.</p> <p>xi. Owner shall deduct GST at source at the applicable rates in case transactions under the Order/Contract are liable to GST deduction at source.</p> <p>xii. Unless expressly stated otherwise, a common mechanism for reconciliation of input credit mismatch, to be followed by both NTPC and Supplier, shall be mutually agreed so that both parties follow the same procedure for disclosing the transactions in their respective returns. Notwithstanding anything in the Order/Contract, penalty / damages shall be recovered in case the Supplier makes a default in following the agreed procedure.</p> <p>xiii. The implications of GST on return of goods will be as per the provisions of the relevant GST Laws.</p> <p>xiv. The Supplier shall issue tax invoices/bill of supply as applicable, file appropriate returns, and deposit the applicable GST to the account of appropriate government within the time limit prescribed under the GST Law. In the event of any default, Supplier shall be liable to pay the amount which may be imposed on NTPC due to such default.</p> <p>xv. Supplier should comply with the provisions of e-way bill notified by appropriate authorities from time to time. The Vendor/Contractor shall be responsible for the issuance of e-way bill and other compliances relating to e-way bill as per GST law.</p> <p>xvi. The Owner shall make necessary tax deductions under Income Tax Act or any other laws, if applicable.</p> <p>xvii. Provisions of GST law in respect of Related Persons/Parties may appropriately be taken into consideration by Bidders while submitting the bid.</p>
--	--	--

		<p>xviii. If any rates of tax are increased or decreased, a new tax is introduced, an existing tax is abolished, or any change in interpretation or application of any tax occurs in the course of the performance of Order/Contract, which was or will be assessed on the Supplier in connection with performance of the Order/Contract, an equitable adjustment shall be made to take into account any such change.</p> <p>xix. The payment/reimbursement of statutory variations in the rates of tax and/or of new tax, duty or levy imposed under statute or law in India as above would be restricted only to direct transactions between the Owner and the Bidder.</p> <p>xx. In case of services covered under Reverse Charge Mechanism, bidder shall quote only basic price for said service and for evaluation the bid of Supplier of Services shall be cost compensated as per the GST rate applicable as per GST Law.</p> <p>xxi. Except as otherwise specifically provided in the Contract, the Bidder shall bear and pay all Taxes, Duties, Levies and Charges including GST, if applicable in connection with the Facilities in and outside of the country where the Site is located.</p> <p>xxii. If any tax exemptions, reductions, allowances or privileges may be available to the Bidder in the country where the Site is located, the Employer shall use its best endeavors to enable the Bidder to benefit from any such tax savings to the maximum allowable extent.</p> <p>xxiii. Income Tax :</p> <p>As per Indian Income Tax Act & Rules, Employer is required to deduct Income Tax at source from all the payments to be made to Non resident/Foreign Bidder/Bidder. For this purpose, the Bidder/Bidder shall be required to either furnish</p> <p>a) the certificate from Indian Tax Authority or</p> <p>b) Ruling from “the Authority for Advance Ruling (AAR)” determining the applicable rate of Income tax in India before release of first payment.</p> <p>The credit of TDS shall be given by the Income Tax Department as per details furnished by the Employer against PAN of the Bidder. The Bidder will be required to submit PAN details to the Engr-in-charge/Project Manager before the submission of the first bill. Further, TDS certificate in line with the provisions of the Income Tax Act 1961 will be issued.</p> <p>The Bidder shall be responsible for payment of any tax levied on the transfer of property and goods involved in accordance with the applicable Act or Notification(s) by the State or Central Government or other authorities and rules made thereunder including amendments, if any. The Bidder shall quote the same in their bid.</p>
--	--	---

38.0	Deleted	Deleted
39.0	<p>PAYMENT TERMS {Clause 62.0 of GPC}</p>	<p>TERMS OF PAYMENT</p> <p>A. Schedule No. 1 : Items/ Hardware and software to be supplied from abroad (Schedule No.1) shall be quoted on CIF (Indian port-of-entry) basis.</p> <p>In respect of Items/ Hardware and software supplied from abroad the following payments shall be made subject to clause no. 39.1 of SPC:</p> <p>I. Five Percent (5%) of the total CIF (Items/ Hardware and software) price component as Initial Advance Payment on :</p> <ul style="list-style-type: none"> i. Acceptance of Notification of Award and Signing of the Contract Agreement. ii. Submission of an unconditional Bank Guarantee covering the advance amount which shall be initially kept valid upto (ninety) 90 days beyond the schedule date for successful Completion of the last facility under the Package. However, in case of delay in completion of facilities, the validity of this Bank Guarantee shall be extended by the period of such delay. Proforma of Bank Guarantee is enclosed in Volume-I SECTION – IV (Forms /Bid Data Sheet) Form of Advance Payment Security. iii. Submission by the Main Contractor of an unconditional Bank Guarantee(s) towards Performance Security(s) in respect of all Contracts (including the Contracts entered into with the Contractor's Assignee, if applicable in case of Foreign Contractor), and submission by the Assignee (if applicable in case of Foreign Contractor) of an unconditional Bank Guarantee(s) towards Performance Security(s) in respect of all Contracts entered into with the Assignee, initially valid upto ninety (90) days after the end of Defects Liability Period of all equipment covered under Contract. The proforma of Bank Guarantee is enclosed in Volume-I SECTION – IV (Forms /Bid Data Sheet) Form of Performance Security. iv. In case Deed of Joint Undertaking by the Contractor alongwith his Associate/Collaborator forms part of the Contract then submission of an unconditional Bank guarantee from such Associate/Collaborator towards faithful performance of the Deed of Joint Undertaking for an amount specified in the deed and initially valid upto ninety (90) days after the end of Defect Liability Period of all equipment covered under the Contract. However, in case of delay in Defect Liability Period, the validity of this Bank Guarantee shall be extended by the period of such delay. The proforma of Bank Guarantee(s) shall be as enclosed in Volume-I SECTION – IV (Forms /Bid Data Sheet). <p>II. Five Percent (5%) of the total Ex-works (Items/ Hardware and software) price component as Interim Advance Payment on</p> <ul style="list-style-type: none"> i. Successful completion of Kick off Meeting at Site ii. Submission and approval (Approval of Employer) of all required

		<p>documents and procedures as advised by EIC</p> <p>iii. Submission of an unconditional Bank Guarantee covering the Interim Advance amount which shall be initially kept valid upto (ninety) 90 days beyond the schedule date of successful Completion of the last facility under the Package. However, in case of delay in completion of facilities, the validity of this Bank Guarantee shall be extended by the period of such delay. Proforma of Bank Guarantee is enclosed in Volume-I SECTION – IV (Forms /Bid Data Sheet) Form of Advance Payment Security.</p> <p>III. Five Percent (5%) of Ex-Works price (Items/ Hardware and software) on receipt of equipment at site on unit wise prorata basis and physical verification and certification by the EIC for the equipment received and stored at site.</p> <p>IV. Twenty five Percent (25%) of Ex-Works price (Items/ Hardware and software) on successful completion of SAT for “SH/RH Temperature Excursion Reduction” on unit wise prorata basis subject to Performance Milestone achieved and corresponding formula for payment as under.</p> <p>V. Ten Percent (10%) of Ex-Works price (Items/ Hardware and software) on successful completion of SAT for “Faster load Ramp up/Ramp Down” on unit wise prorata basis subject to Performance Milestone achieved and corresponding formula for payment as under.</p> <p>VI. Forty Percent (40%) of Ex-Works price (Items/ Hardware and software) on successful completion of SAT for “Combustion Optimization & Soot Blowing Optimization” on unit wise prorata basis subject to Performance Milestone achieved and corresponding formula for payment as under.</p> <p>VII. Five (5%) of Ex-Works price (Items/ Hardware and software) on successful completion of SAT for “Reduce Min. stable load” on unit wise prorata basis subject to Performance Milestone achieved and corresponding formula for payment as under.</p> <p>Milestone achieved linked payment formula</p> <table border="1" data-bbox="690 1354 1485 1894"> <thead> <tr> <th data-bbox="690 1354 750 1501">Sl. No</th> <th data-bbox="750 1354 1015 1501">Performance Milestone</th> <th data-bbox="1015 1354 1485 1501">Milestone</th> </tr> </thead> <tbody> <tr> <td data-bbox="690 1501 750 1894">A</td> <td data-bbox="750 1501 1015 1894">Net Improvement in Standard Deviation of SH & RH steam temperature excursion (as per clause 8.16 of Volume III - Technical specifications and scope of work)</td> <td data-bbox="1015 1501 1485 1894"> <p>1. For, Net Improvement in Standard Deviation of SH & RH steam temperature excursion between 10% to 50%, payment shall be in the range of 5% to 25% of PO price.</p> <p>Example: Net Improvement = 30%, payment (incl. Tax) is calculated as follows: $5\% + [\{ (25\%-5\%) / (50\%-10\%) \} * (30\% - 10\%)]$</p> <p>2. For Net Improvement in Standard Deviation of SH & RH steam temperature</p> </td> </tr> </tbody> </table>	Sl. No	Performance Milestone	Milestone	A	Net Improvement in Standard Deviation of SH & RH steam temperature excursion (as per clause 8.16 of Volume III - Technical specifications and scope of work)	<p>1. For, Net Improvement in Standard Deviation of SH & RH steam temperature excursion between 10% to 50%, payment shall be in the range of 5% to 25% of PO price.</p> <p>Example: Net Improvement = 30%, payment (incl. Tax) is calculated as follows: $5\% + [\{ (25\%-5\%) / (50\%-10\%) \} * (30\% - 10\%)]$</p> <p>2. For Net Improvement in Standard Deviation of SH & RH steam temperature</p>
Sl. No	Performance Milestone	Milestone						
A	Net Improvement in Standard Deviation of SH & RH steam temperature excursion (as per clause 8.16 of Volume III - Technical specifications and scope of work)	<p>1. For, Net Improvement in Standard Deviation of SH & RH steam temperature excursion between 10% to 50%, payment shall be in the range of 5% to 25% of PO price.</p> <p>Example: Net Improvement = 30%, payment (incl. Tax) is calculated as follows: $5\% + [\{ (25\%-5\%) / (50\%-10\%) \} * (30\% - 10\%)]$</p> <p>2. For Net Improvement in Standard Deviation of SH & RH steam temperature</p>						

				<p>excursion of 10% ; Payment of 5% of PO price (incl. Tax).</p> <p>3. For Net Improvement in Standard Deviation of SH & RH steam temperature excursion of <10%; no payment.</p>
		B	<p>Net Improvement in Standard Deviation of Throttle Pressure, SH and RH steam temperature excursion (as per clause 8.16 of Volume III - Technical specifications and scope of work)</p>	<p>1. For, Net Improvement in Standard Deviation of Throttle Pressure, SH and RH steam temperature excursion between 10% to 50%, payment shall be in the range of 2% to 10% of PO price.</p> <p>Example: Net Improvement = 30%, payment (incl. Tax) is calculated as follow: $2\% + [\{ (10\%-2\%) / (50\%-10\%) \} * (30\% - 10\%)]$</p> <p>2. For Net Improvement in Standard Deviation of Throttle Pressure, SH and RH steam temperature excursion of 10% ; Payment of 2% of PO price (incl. Tax).</p> <p>3. For Net Improvement in Standard Deviation of Throttle Pressure, SH and RH steam temperature excursion of <10%; no payment.</p>
		C	<p>Net Improvement in Unit Heat Rate by Combustion optimization and Soot blowing optimization (Summation of results of SAT of each of this APC solution) (as per clause 8.16 of Volume III - Technical specifications and scope of work)</p>	<p>1. For Net improvement in Unit Heat rate between 0.1% to 0.5%, payment shall be in the range of 8% to 40% of PO price.</p> <p>Example: Heat rate improvement = 0.15%, payment (incl. Tax) is calculated as follow: $8\% + [\{ (40\%-8\%) / (0.5\% - 0.1\%) \} * (0.15\% - 0.1\%)]$</p> <p>2. For Net improvement in Unit Heat rate of 0.1% ; Payment of 8% of PO price (incl. Tax).</p> <p>3. For Net improvement in Unit Heat rate of <0.1% ; no payment.</p>
		D	<p>Improvement in Stable Min. Load (as per clause 8.16 of Volume III - Technical specifications and scope of work)</p>	<p>1. For Achieving Stable Min load of 50% loading factor, payment of 5% of PO price</p>
		VIII.	<p>Ten percent (10%) of Ex-Works price (Items/ Hardware and software) on Completion of Facilities unitwise and its Certification by the Project Manager/EIC.</p>	
		B.	<p>Schedule No. 2 : Items/ Hardware and software to be supplied from within the Employer's Country (Schedule No. 2) quoted on Ex-works (India) basis:</p> <p>In respect of Items/ Hardware and software supplied from within the Employer's country the following payment shall be made subject to clause no. 39.1 of SPC:</p>	

		<p>I. Five Percent (5%) of the total Ex-works (Items/ Hardware and software) price component as Initial Advance Payment on :</p> <ol style="list-style-type: none"> i. Acceptance of Notification of Award and Signing of the Contract Agreement. ii. Submission of an unconditional Bank Guarantee covering the advance amount which shall be initially kept valid upto (ninety) 90 days beyond the schedule date for successful Completion of the last facility under the Package. However, in case of delay in completion of facilities, the validity of this Bank Guarantee shall be extended by the period of such delay. Proforma of Bank Guarantee is enclosed in Volume-I SECTION – IV (Forms /Bid Data Sheet) Form of Advance Payment Security. iii. Submission by the Main Contractor of an unconditional Bank Guarantee(s) towards Performance Security(s) in respect of all Contracts (including the Contracts entered into with the Contractor's Assignee, if applicable in case of Foreign Contractor), and submission by the Assignee (if applicable in case of Foreign Contractor) of an unconditional Bank Guarantee(s) towards Performance Security(s) in respect of all Contracts entered into with the Assignee, initially valid upto ninety (90) days after the end of Defects Liability Period of all equipment covered under Contract. The proforma of Bank Guarantee is enclosed in Volume-I SECTION – IV (Forms /Bid Data Sheet) Form of Performance Security. iv. In case Deed of Joint Undertaking by the Contractor alongwith his Associate/Collaborator forms part of the Contract then submission of an unconditional Bank guarantee from such Associate/Collaborator towards faithful performance of the Deed of Joint Undertaking for an amount specified in the deed and initially valid upto ninety (90) days after the end of Defect Liability Period of all equipment covered under the Contract. However, in case of delay in Defect Liability Period, the validity of this Bank Guarantee shall be extended by the period of such delay. The proforma of Bank Guarantee(s) shall be as enclosed in Volume-I SECTION – IV (Forms /Bid Data Sheet). <p>II. Five Percent (5%) of the total Ex-works (Items/ Hardware and software) price component as Interim Advance Payment on</p> <ol style="list-style-type: none"> i. Successful completion of Kick off Meeting at Site ii. Finalization, submission and approval (Approval of Employer) of all required documents and procedures as advised by EIC iii. Submission of an unconditional Bank Guarantee covering the Interim Advance amount which shall be initially kept valid upto (ninety) 90 days beyond the schedule date of successful Completion of the last facility under the Package. However, in case of delay in completion of facilities, the validity of this Bank Guarantee shall be extended by the period of such delay. Proforma of Bank Guarantee is enclosed in
--	--	---

Volume-I SECTION – IV (Forms /Bid Data Sheet) Form of Advance Payment Security.

- III. Five Percent (5%) of Ex-Works price (Items/ Hardware and software) on receipt of equipment at site on unit wise prorata basis and physical verification and certification by the EIC for the equipment received and stored at site.
- IV. Twenty five Percent (25%) of Ex-Works price (Items/ Hardware and software) on successful completion of SAT for “SH/RH Temperature Excursion Reduction” on unit wise prorata basis subject to Performance Milestone achieved and corresponding formula for payment as under.
- V. Ten Percent (10%) of Ex-Works price (Items/ Hardware and software) on successful completion of SAT for “Faster load Ramp up/Ramp Down” on unit wise prorata basis subject to Performance Milestone achieved and corresponding formula for payment as under.
- VI. Forty Percent (40%) of Ex-Works price (Items/ Hardware and software) on successful completion of SAT for “Combustion Optimization & Soot Blowing Optimization” on unit wise prorata basis subject to Performance Milestone achieved and corresponding formula for payment as under.
- VII. Five (5%) of Ex-Works price (Items/ Hardware and software) on successful completion of SAT for “Reduce Min. stable load” on unit wise prorata basis subject to Performance Milestone achieved and corresponding formula for payment as under.

Milestone achieved linked payment formula

Sl. No	Performance Milestone	Milestone
A	Net Improvement in Standard Deviation of SH & RH steam temperature excursion (as per clause 8.16 of Volume III - Technical specifications and scope of work)	<p>1. For, Net Improvement in Standard Deviation of SH & RH steam temperature excursion between 10% to 50%, payment shall be in the range of 5% to 25% of PO price.</p> <p>Example: Net Improvement = 30%, payment (incl. Tax) is calculated as follows: $5\% + [\{ (25\%-5\%) / (50\%-10\%) \} * (30\% - 10\%)]$</p> <p>2. For Net Improvement in Standard Deviation of SH & RH steam temperature excursion of 10% ; Payment of 5% of PO price (incl. Tax).</p> <p>3. For Net Improvement in Standard Deviation of SH & RH steam temperature excursion of <10%; no payment.</p>
B	Net Improvement in Standard Deviation of Throttle Pressure, SH	1. For, Net Improvement in Standard Deviation of Throttle Pressure, SH and RH steam temperature excursion between

			and RH steam temperature excursion (as per clause 8.16 of Volume III - Technical specifications and scope of work)	<p>10% to 50%, payment shall be in the range of 2% to 10% of PO price.</p> <p>Example: Net Improvement = 30%, payment (incl. Tax) is calculated as follow: $2\% + [\{ (10\% - 2\%) / (50\% - 10\%) \} * (30\% - 10\%)]$</p> <p>2. For Net Improvement in Standard Deviation of Throttle Pressure, SH and RH steam temperature excursion of 10% ; Payment of 2% of PO price (incl. Tax).</p> <p>3. For Net Improvement in Standard Deviation of Throttle Pressure, SH and RH steam temperature excursion of <10%; no payment.</p>
		C	Net Improvement in Unit Heat Rate by Combustion optimization and Soot blowing optimization (Summation of results of SAT of each of this APC solution) (as per clause 8.16 of Volume III - Technical specifications and scope of work)	<p>1. For Net improvement in Unit Heat rate between 0.1% to 0.5%, payment shall be in the range of 8% to 40% of PO price.</p> <p>Example: Heat rate improvement = 0.15%, payment (incl. Tax) is calculated as follow: $8\% + [\{ (40\% - 8\%) / (0.5\% - 0.1\%) \} * (0.15\% - 0.1\%)]$</p> <p>2. For Net improvement in Unit Heat rate of 0.1% ; Payment of 8% of PO price (incl. Tax).</p> <p>3. For Net improvement in Unit Heat rate of <0.1% ; no payment.</p>
		D	Improvement in Stable Min. Load (as per clause 8.16 of Volume III - Technical specifications and scope of work)	<p>1. For Achieving Stable Min load of 50% loading factor, payment of 5% of PO price.</p>
		VIII.	Ten percent (10%) of Ex-Works price (Items/ Hardware and software) on Completion of Facilities unitwise and its Certification by the Project Manager/EIC.	
		C.	<p>Schedule No. 3 : Local Transportation</p> <p>Hundred Percent (100%) Local Transportation (including inland insurance charges) for the Items/ Hardware and software covered in Schedule-2 shall be paid to the Contractor on receipt of equipment at site on unit wise Prorata basis and on production of invoices by the Contractor.</p>	
		D.	<p>Schedule No. 4 : Installation Services (including AMC)</p> <p>I. Installation Services (excluding AMC)</p> <p>Installation Services component shall be paid as under: Hundred percent (100%) of Installation Services component of each unit will be paid on successful completion of SAT and certification by the EIC.</p>	
		II.	Annual Maintenance Contract(AMC)	

		<p>The Contractor shall be eligible for payment under the Annual Maintenance Contract (AMC) on quarterly pro-rata basis on certification by EIC regarding successful maintenance of the system by the Contractor subject to clause no. 39.1 of SPC.</p> <p>E. Schedule - 6 : Payment Terms for Taxes & Duties</p> <p>I. Indian Custom Duties or levies including Stamp Duty and Import Licence Fee if imposed in future and IGST on Imports by the Government of India or any State Government in India on the Items/ Hardware and software covered in Schedule -1 supplied from abroad to be imported into India and which will become the property of the Employer shall be paid directly by the Employer to the Government of India or the concerned authorities. However, if the local laws require such payment of the Custom duty, IGST and any other levies on imports to be made by the Contractor, the same shall be reimbursed to the Contractor on production of satisfactory evidence of having paid the custom duty amount to the concerned authorities.</p> <p>II. Notwithstanding the above, if the Contractor chooses to ship the equipment in Shipper's Containers, then the Custom duty, IGST and any other levies on imports levied on such Containers shall not be borne by the Employer and shall be payable by the Contractor himself.</p> <p>III. 100% of applicable Taxes and Duties [other than the Custom duty, IGST and any other levies on imports payable as in para (i) above] which are payable by the Employer under the Contract shall be reimbursed by the Employer to the Contractor/Assignee upon receipt of equipment at site on production of satisfactory documentary evidence by the Contractor/Assignee, as applicable as per relevant GST Laws</p>
<p>39.1</p>	<p>HIGH/LOW QUOTED RATES OF ANNUAL MAINTENANCE CONTRACT (AMC)</p>	<p>In case the quoted price for Annual Maintenance Contract (AMC) for 03 (three) years is less than 5 % of total awarded package price (excluding tax), then an amount equal to the 'difference of (5% of total awarded package price) and quoted price for (AMC for 03 (three) years)' shall be retained from all the payment as "Retained Amount" and same shall be released proportionately along with quarterly AMC payment.</p>
<p>40.0</p>	<p>INTEGRITY PACT {Clause 67.0 of GPC}</p>	<p>Bidders are required to unconditionally accept the "Integrity Pact (IP)" (executed on plain paper) as per relevant Attachment to the Bidding Documents which has been pre-signed by the Employer, and submit the same duly signed on all pages by the bidder's authorized signatory alongwith the bid.</p> <p>The Integrity Pact (IP) is to be submitted in sealed envelope. Bidder's failure to comply with the aforesaid requirement regarding submission of 'Integrity Pact (IP)' shall lead to outright rejection of the bid and in such case the bids shall be returned unopened to the bidder.</p>

<p>40.1</p>	<p>INDEPENDENT EXTERNAL MONITORS (IEM)s</p>	<p>In respect of this package, the Independent External Monitors (IEMs) would be monitoring the bidding process and execution of contract to oversee implementation and effectiveness of the Integrity Pact Program.</p> <p>The names of Independent External Monitor(s) (IEMs) who have been appointed by EMPLOYER, in terms of Integrity Pact (IP) which forms parts of the EMPLOYER Tenders/Contracts are provided at NTPC website http://www.ntpc tender.com (under the tab 'Integrity Pact')</p> <p>This panel is authorized to examine /consider all references made to it under this tender. The bidder(s), in case of any dispute(s) / complaint(s) pertaining to this package may raise the issue either with the designated 'Nodal Officer' in EMPLOYER or directly with the IEMs at following Address:</p> <p>"The IEMs' Secretariat, Contracts Services, 6th Floor, EOC, NTPC Limited, A-8A, Sector-24, Noida-201301 (UP)."</p> <p>The Independent External Monitors (IEMs) has the right to access without restriction to all Project documentations of the Employer including that provided by the Contractor. The Contractor will also grant the Monitor, upon his request and demonstration of a valid interest, unrestricted and unconditional access to his Project Documentations. The same is applicable to Subcontractors. The Monitor is under contractual obligation to treat the information and documents of the Bidder / Contractor / Sub-Contractors/ JV partners/ Consortium member with confidentiality.</p> <p>The Nodal Officer for necessary coordination in this regard shall be as under:</p> <ul style="list-style-type: none"> (i) GM (CM) / AGM (CM) heading the concerned group: if the issue pertains to Corporate Materials (ii) Head of Contracts & Materials Department: if the issue pertains to Regional office (iii) Head of concerned department: if the issue pertains to other departments (iv) Head of Project/ Station: if the issue pertains to Project.
<p>41.0</p>	<p>QUALIFICATION</p>	<p>The Employer will ascertain to its satisfaction whether bidders determined as having submitted responsive Techno-Commercial bids are qualified to satisfactorily perform the contract.</p> <ul style="list-style-type: none"> a) The determination will take into account the Bidder's financial, technical capabilities and past performance. It will be based upon an examination of the documentary evidence of the Bidder's qualifications submitted by the Bidder as well as such other information as the Employer deems necessary and appropriate. b) An affirmative determination will be a prerequisite for the Employer to invite the Bidder to a clarification meeting. A negative determination

		will result in rejection of the Bidder's bid.
42.0	TECHNICAL EVALUATION AND COMPARISON OF BIDS	<p>Evaluation of bids shall be carried out on the basis of Technical and commercial bid and the Price Bid submitted by the bidder.</p> <p>During the course of Detailed technical evaluation, Employer shall examine the bids to determine whether they are complete, whether required guarantees have been furnished, whether document have been properly submitted and whether bids are generally in order. Material deficiencies in the bid may render the bid as non responsive and lead to rejection of the bid.</p> <p>Detailed Technical evaluation will be carried out to determine as to whether technical aspects are in accordance with the requirements set forth in this document.</p> <p>The Employer's determination of a bid's responsiveness is to be based on the contents of the bid itself without recourse to extrinsic evidence. If a bid is not substantially responsive, it will be rejected by the Employer, and may not subsequently be made responsive by the Bidder by correction of the nonconformity.</p> <p>The Employer will ascertain to its satisfaction whether bidders determined as having submitted responsive Techno-Commercial bid are qualified to satisfactorily perform the contract.</p> <p>a) The determination will take into account the Bidder's financial, technical capabilities and past performance. It will be based upon an examination of the documentary evidence of the Bidder's qualifications submitted by the Bidder as well as such other information as the Employer deems necessary and appropriate.</p> <p>b) An affirmative determination will be a prerequisite for the Employer to invite the Bidder to a clarification meeting. A negative determination will result in rejection of the Bidder's bid.</p> <p>c) The capabilities of the vendors and sub--contractors, proposed will also be evaluated for acceptability. Their participation should be confirmed with a letter of intent between the parties, as needed. Should a vendor or sub-supplier be determined to be unacceptable, the bid will not be rejected, but the Bidder will be required to substitute an acceptable vendor or sub-Supplier, prior to award.</p> <p>The Employer will carry out a detailed evaluation of the bids previously determined to be substantially responsive in order to determine whether the technical aspects are in accordance with the requirements set forth in the bidding documents. In order to reach such a determination, the Employer will examine and compare the technical aspects of the bids on the basis of the information supplied by the bidders, taking into account the following factors:</p> <p>(a) overall completeness and compliance with the Technical Specifications and Drawings; suitability of the solution offered in</p>

		<p>relation to requirement specified in the bid documents. The bid that does not meet acceptable standards of completeness, consistency and detail will be rejected for non-responsiveness.</p> <ul style="list-style-type: none"> (b) Achievement of specified performance criteria by the solution (c) Any other relevant factors, if any, listed in the Bid documents or that the Employer deems necessary or prudent to take into consideration (d) Compliance with the time schedule as specified in bidding documents. <p>The Techno-commercial examination will ascertain that the bidder fully meets the Qualifying Requirements, stipulated for the works to the Employer's satisfaction. The determination will take into account the Bidder's financial, technical and solution capabilities. It will be based upon an examination of documentary evidence of Bidder's qualifications submitted by the Bidder in Attachment-7 to the Techno-Commercial Bid, as well as such other information as the Employer deems necessary and appropriate.</p> <p>The Employer will also carry out the evaluation of the Techno-Commercial Bids (of the qualified bidders as above) on the basis of their responsiveness to the scope of the services. Technical Specification and other terms and conditions specified in the Bidding Documents.</p> <p>An affirmative determination will be prerequisite for opening of Price Bid. A negative determination will result in rejection of the Bidder's Techno-Commercial Bid and such Bidders Price Bid will not be opened.</p> <p>The capabilities of the vendors and sub-contractors, proposed by the Bidder will also be evaluated for acceptability. Their participation should be confirmed with a letter of intent between the parties, as needed. Should a vendor or sub-contractor be determined to be unacceptable, the bid will not be rejected, but the bidder will be required to substitute an acceptable vendor or sub-contractor without any change in the bid price quoted in Price Bid, prior to award.</p> <p>During the evaluation of Techno-Commercial Bids, if required, discussions or clarification meeting shall be carried out with only those Bidders who have been considered qualified and whose Techno-Commercial Bid have been found to be responsive. The objective of the exercise is to resolve all issues including vendor finalization, work schedule, etc. with the qualified and responsive bidders prior to opening of price bids.</p>
<p>43.0</p>	<p>EVALUATION OF TECHNO-COMMERCIAL BIDS</p>	<p>Bid submitted by Bidder's will be evaluated as described below:</p> <p>The Employer will carry out a detailed evaluation of the Bids in order to determine whether the technical aspects are in accordance with the requirements set forth in the bidding documents. In order to reach such a determination, the Employer will examine and compare the technical aspects of the bids on the basis of the information supplied by the bidders, taking into account</p>

		<p>a) the overall completeness and compliance with the Technical Specifications; to the bid and compliance to other provisions of the bidding documents. The bid that does not meet acceptable standards of completeness, consistency and detail will be rejected for non-responsiveness.</p> <p>b) Any other relevant factors, if any, listed in the Technical specifications, or that the Employer deems necessary or prudent to take into consideration.</p> <p>c) Compliance with the time schedule as specified in the bidding documents.</p> <p>EMPLOYER's determination of a bid's responsiveness is to be based on the contents of the bid itself without recourse to extrinsic evidence. If a bid is not substantially responsive, it will be rejected by EMPLOYER, and may not subsequently be made responsive by the Bidder by correction of the nonconformity.</p>
44.0	PRELIMINARY EXAMINATION OF (PRICE) BIDS	<p>The Employer will examine the Price bids to determine whether they are complete, whether any computational errors have been made, whether the documents have been properly signed, and whether the bids are generally in order. The Employer may, at its discretion, ask the Bidder for a clarification of its bid. The request for clarification and the response shall be in writing, and no change in the price or substance of the bid shall be sought, offered or permitted.</p> <p>Arithmetic errors will be rectified on the following basis:</p> <p>If there is a discrepancy between the unit price and the total price that is obtained by multiplying the unit price and quantity, or between subtotals and the total price, the unit or subtotal price shall prevail and the total price shall be corrected. If there is a discrepancy between words and figures, the amount in words will prevail. If the Bidder does not accept the correction of errors, its bid will be rejected and the bid security forfeited in accordance with GPC Sub-Clause 10.0 (b).</p> <p>If considered necessary, Employer, at its discretion, may call bidder for discussion after opening of Price Bid.</p>
45.0	EVALUATION OF PRICE BID	<p>The comparison shall be on Door Delivery at Site basis. However, the Price of Optional/Recommended Spares shall not be considered for evaluation of Bids.</p> <p>The comparison shall be on the summation of the arithmetically corrected total price in the Price Schedule.</p> <p>To facilitate evaluation & comparison the Employer will convert all bid prices, expressed in the amounts in various currencies in which bid price is payable into a single currency i.e. Indian Rupees Bills Selling Exchange as per Rate established by State Bank of India as on the date of opening of Techno-Commercial Bids. Arithmetical errors will be corrected as per clause 29.0 of GPC.</p>

		The Bid shall be evaluated as per methodology given above.																											
46.0	BENEFITS TO MSEs	<p>In accordance with clause 2.1 of GPC in the tender, participating MSEs whose Evaluated Unit Package Price (EUP) is within price band of L1 + 15 percent shall be allowed to execute the one unit by bringing down their Evaluated Unit Package Price (EUP) to L1 price in a situation where L1 price is from someone other than a Micro and Small Enterprise.</p> <p><i>The award shall be made as follows:</i></p> <p>a) Award for two units shall be given to L1 bidder if L1 bidder is a MSE .</p> <p>b) In case L1 bidder is not a MSE, then all the MSE vendor(s) who have quoted the Evaluated Unit Package Price (EUP) within the range of L1 + 15%, shall be given the opportunity in order of their ranking (starting with the lowest quoted MSE bidder and so on) to bring down its Evaluated Unit Package Price (EUP) to match with L1 bidder. Award shall be placed for one unit on the MSE vendor who matches the Evaluated Unit Package Price (EUP) by L1 bidder.</p> <p>c) If no MSE vendor who has quoted within range of L1 + 15% accepts the Evaluated Unit Package Price (EUP) of L1 bidder then the award shall be made as per clause 47.0 of SPC.</p>																											
47.0	ILLUSTRATIVE METHOD OF EVALUATION	<p>Domestic bidders shall quote the prices for supply of Items/ Hardware and software only on Ex-Works (India) basis. Bidders offering the prices for supply of Items/ Hardware and software on CIF basis or in a mix of Ex-Works India basis plus CIF basis would be classified as foreign bidders.</p> <p>All the bids which are determined to be qualified and found to be technically responsive shall be evaluated on Door Delivery at Site basis inclusive of all taxes & duties. An illustrative method of evaluation is given below:</p> <table border="1"> <tr> <td>1</td> <td>Quoted Bid Price (after considering arithmetical errors)</td> <td>(Equivalent INR)</td> </tr> <tr> <td>i.</td> <td>CIF Price (Schedule 1)</td> <td>M1</td> </tr> <tr> <td>ii.</td> <td>Ex-Works Price (Schedule 2)</td> <td>M2</td> </tr> <tr> <td>iii.</td> <td>Local Transportation Price (Schedule 3)</td> <td>M3</td> </tr> <tr> <td>iv.</td> <td>Installation Services Price (Schedule 4)</td> <td>M4</td> </tr> <tr> <td>v.</td> <td>Total Price</td> <td>M (M1+M2+M3+M4)</td> </tr> <tr> <td>2</td> <td>Taxes & Duties (not included in 1 above)</td> <td></td> </tr> <tr> <td>i.</td> <td>Custom Duty & GST on imports</td> <td>Q1</td> </tr> <tr> <td>ii.</td> <td>GST on EXW price (Schedule 6)</td> <td>Q2</td> </tr> </table>	1	Quoted Bid Price (after considering arithmetical errors)	(Equivalent INR)	i.	CIF Price (Schedule 1)	M1	ii.	Ex-Works Price (Schedule 2)	M2	iii.	Local Transportation Price (Schedule 3)	M3	iv.	Installation Services Price (Schedule 4)	M4	v.	Total Price	M (M1+M2+M3+M4)	2	Taxes & Duties (not included in 1 above)		i.	Custom Duty & GST on imports	Q1	ii.	GST on EXW price (Schedule 6)	Q2
1	Quoted Bid Price (after considering arithmetical errors)	(Equivalent INR)																											
i.	CIF Price (Schedule 1)	M1																											
ii.	Ex-Works Price (Schedule 2)	M2																											
iii.	Local Transportation Price (Schedule 3)	M3																											
iv.	Installation Services Price (Schedule 4)	M4																											
v.	Total Price	M (M1+M2+M3+M4)																											
2	Taxes & Duties (not included in 1 above)																												
i.	Custom Duty & GST on imports	Q1																											
ii.	GST on EXW price (Schedule 6)	Q2																											

		<table border="1"> <tr> <td>iii.</td> <td>Other Taxes</td> <td>Q3</td> </tr> <tr> <td>iv.</td> <td>Taxes on RCM (Schedule 8)</td> <td>Q4</td> </tr> <tr> <td>v.</td> <td>Total</td> <td>Q (Q1+Q2+Q3+Q4)</td> </tr> <tr> <td>3</td> <td>Evaluated Unit Package</td> <td>EP (M+Q)</td> </tr> </table> <p>Evaluation shall be done on Unit Package Price Basis. The bidders will be ranked on the basis of the evaluated Unit Package Price Basis.</p> <p>Bid prices would be ranked in ascending order as L1, L2, L3 and so on, with L1 being the lowest Unit Package Price.</p> <p>The Employer will award the contract to the Bidders as per following methodology:</p> <ol style="list-style-type: none"> I. The Lowest Bidder L1 will be awarded two units. The other Bidders given the opportunity in order of their ranking (starting with L2 bidder and so on) to bring down their Unit Package Price to match with L1 bidder. This process shall be followed till the remaining two units are awarded. II. In case any bidder, who is given an opportunity to match the prices (in the order of their ranking), disagrees to do so, he shall be disqualified from award. III. Any unit(s) which remains undecided up to the last ranked bidder shall be offered to the L1 Bidder. <p>Bidder may note that for the purpose of matching of lowest Evaluated Unit Package Price (EUP), as per clause 47.0 of SPC, the bidder would have to necessarily reduce all components of the quoted price on pro-rata basis such that the summation of the revised / reduced quoted price is equal to the lowest Evaluated Unit Package Price (EUP).</p> <p>The employer at its discretion would allocate specific Unit(s) to successful Bidders at time of award of contract and same would be bidding on the successful Bidders.</p> <p>Benefits to MSEs shall be given as per clause 46.0 above.</p>	iii.	Other Taxes	Q3	iv.	Taxes on RCM (Schedule 8)	Q4	v.	Total	Q (Q1+Q2+Q3+Q4)	3	Evaluated Unit Package	EP (M+Q)
iii.	Other Taxes	Q3												
iv.	Taxes on RCM (Schedule 8)	Q4												
v.	Total	Q (Q1+Q2+Q3+Q4)												
3	Evaluated Unit Package	EP (M+Q)												
48.0	EVALUATION CRITERIA {Clause 27.0 of GPC}	<p>Evaluation shall be done on Unit Package basis.</p> <p>The total Unit package price shall be the price arrived as per methodology given above.</p> <p>The awarded rates shall remain valid and firm throughout the contract period.</p> <p>Bidders must quote for all the items in the online BPS and Price Schedule</p>												

		<p>(excel files).</p> <p>In case a bidder does not quote the rate for any item or quotes the price as “0”, the price of such item(s) shall be considered to be included in the Unit package price.</p> <p>Benefits to MSEs shall be provided as specified in SPC clause 46.0</p> <p>The evaluation criteria over-rides all other similar related clauses appearing anywhere in the bid documents, and such clauses are deemed to have been modified to the extent stipulated above.</p>
49.0	CONSTRUCTION OF CONTRACT	<p>In the case of successful Bidder, the award shall be made as follows:</p> <ul style="list-style-type: none"> (i) First Contract : For CIF (Indian port of entry) supply of Items/ Hardware and software to be supplied from abroad. (ii) Second Contract : For Ex-works (India) supply of Items/ Hardware and software. (iii) Third Contract : For providing all services i.e. port handling, port clearance and port charges for the imported goods, further loading, inland transportation for delivery at site, inland transit insurance, unloading, storage, handling at site, installation, insurance covers other than inland transit insurance, testing, commissioning and conducting SAT, warranty and AMC in respect of all the Items/ Hardware and software supplied under the 'First Contract' & the 'Second Contract' and all other services as specified in the Contract Documents. <p>All the above Contracts will contain a cross-fall breach clause specifying that breach of one Contract will constitute breach of the other Contracts which will confer a right on the Employer to terminate the other Contracts also at the risk and the cost of the Contractor.</p>
50.0	CHANGE CONTRACT IN	<p>50.1 Introducing a Change</p> <p>50.1.1 The Employer shall have the right to propose, and subsequently require, that the Project Manager order the Contractor from time to time during the performance of the Contract to make any change, modification, addition or deletion to, in or from the Facilities (hereinafter called “Change”), provided that such Change falls within the general scope of the Facilities and does not constitute unrelated work and that it is technically practicable, taking into account both the state of advancement of the Facilities and the technical compatibility of the Change envisaged with the nature of the Facilities as specified in the Contract .</p> <p>50.1.2 The Contractor may from time to time during its performance of the Contract propose to the Employer (with a copy to the Project Manager) any Change that the Contractor considers necessary or desirable to improve the quality, efficiency or safety of the Facilities. The Employer may at its discretion approve or reject any</p>

		<p>Change proposed by the Contractor.</p> <p>50.1.3 Notwithstanding SPC Sub-Clauses 50.1.1 and 50.1.2, no change made necessary because of any default of the Contractor in the performance of its obligations under the Contract shall be deemed to be a Change, and such change shall not result in any adjustment of the Contract Price or the Time for Completion.</p> <p>50.1.4 The procedure on how to proceed with and execute Changes is specified in SPC Sub-Clauses 50.2 .</p> <p>50.2 Procedure</p> <p>50.2.1 If the Employer proposes a Change pursuant to SPC Sub-Clause 50.1.1, it shall send to the Contractor a “Request for Change Proposal,” requiring the Contractor to prepare and furnish to the Project Manager as soon as reasonably practicable a “Change Proposal,” which shall include the following:</p> <ul style="list-style-type: none"> (a) brief description of the Change (b) effect on the Time for Completion (c) estimated cost of the Change (d) effect on Functional Guarantees (if any) (e) effect on any other provisions of the Contract. <p>50.2.2 The pricing of any Change shall, as far as practicable, be calculated in accordance with the rates and prices included in the Contract. If the rates and prices of any change are not available in the Contract, the parties thereto shall agree on specific rates for the valuation of the Change.</p> <p>50.2.3 If the Contractor proposes a Change pursuant to SPC Sub-Clause 50.1.2, the Contractor shall submit to the Project Manager a written “Application for Change Proposal,” giving reasons for the proposed Change and including the information specified in SPC Sub-Clause 50.2.1.</p> <p>50.2.4 Upon receipt of the Change Proposal, the Employer and the Contractor shall mutually agree upon all matters therein contained including agreement on rates if such rates are not available in the Contract.</p> <p>If the Employer is unable to reach a decision within thirty (30), it shall notify the Contractor with details of when the Contractor can expect a decision.</p> <p>If the Employer decides not to proceed with the Change for whatever reason, it shall, within the said period of thirty (30) days, notify the Contractor accordingly.</p> <p>50.2.5 If the Employer and the Contractor cannot reach agreement on the price for the Change, an equitable adjustment to the Time for Completion, or any other matters identified in the Change Proposal, the Employer may nevertheless instruct the Contractor to proceed with the Change by issue of a “Pending Agreement Change</p>
--	--	---

		<p>Order.”</p> <p>Upon receipt of a Pending Agreement Change Order, the Contractor shall immediately proceed with effecting the Changes covered by such Order. The parties shall thereafter attempt to reach agreement on the outstanding issues under the Change Proposal.</p> <p>If the parties cannot reach agreement within ninety (90) days from the date of issue of the Pending Agreement Change Order, then the matter may be referred for Arbitration in accordance with the provisions of GPC clause 56 (SETTLEMENT OF DISPUTES).</p>
51.0	SUBCONTRACTING	<p>The Contractor shall not sub-contract any portion of the contract without the prior written approval of the Engineer-in-charge. The list of sub-contractors with experience details shall be submitted to Engineer-in-charge for approval. The Contractor shall submit any such list or any modification thereto to the Employer for its approval in sufficient time so as not to impede the progress of work on the package. Such approval by the Employer for any of the Subcontractors shall not relieve the Contractor from any of its obligations, duties or responsibilities under the Contract. Employment of piece rate workers shall not be deemed as sub-contracting. The responsibility for execution of Contract shall be with the Contractor to whom the work is awarded.</p> <p>The Bidder shall be responsible for ensuring that any Items/ Hardware and software or services to be provided by the Sub-Contractor/Vendor comply with the requirements of Bidding documents. Quoted rates and prices will be deemed to apply to whichever Subcontractor/Vendor is appointed, and no adjustment of the rates and prices will be permitted.</p>
52.0	<p>SUBMISSION OF EMD & OTHER DOCUMENTS</p> <p>{Clause 19.0, 21.0 & 22.0 of GPC}</p>	
	OFF – LINE	<p>The bidders are requested to send following documents in sealed envelopes well in advance so as to be received well before the last date of submission of bids as described in the time schedule in Notice Inviting Tender failing which bid shall be rejected.</p> <p>Envelope-1</p> <ul style="list-style-type: none"> i) Bid Form 1 { Bid form of Vol. I Section IV} ii) EMD { In line with SPC Cl. 4.0& GPC Cl. 9.0} iii) MSE certificate (if applicable) iv) EFT form (Attachment 12) duly filled and certified by Bank along with cancelled cheque v) Integrity Pact duly signed <p>The Employer shall first open Envelope 1 (submitted offline) of all the bidders. Based on the Bid Security</p>

		<p>and Acceptance of Important Conditions, bids of only those bidders will be opened whose Bid Security and Acceptance of Important Conditions is acceptable as per conditions of the bid document.</p> <p>Envelope-2</p> <ul style="list-style-type: none"> i) Power of Attorney/Authority to sign the bid A power of attorney, duly authorised by a Notary Public, indicating that the person(s) signing the bid has/have the authority to sign and the bid and the bid is binding upon the Bidder during the full period of its validity in accordance with SPC Clause 3.0. It may be noted that notarised Power of Attorney in the name of person who has digitally signed this bid is to be submitted offline and scanned copy to be attached in C Folder. The Authority of the person issuing the Power of Attorney backed by a copy of board resolution/other relevant documents to demonstrate the authority of the person issuing the power of attorney shall also be submitted. ii) Client certificate(s) vi) Appendix(s) to attachment 7B-1 vii) Appendix(s) to attachment 7B-2 viii) Deed of Joint Undertaking of bidder and associate {Attachment 7C-1/7C-2/7C-3} ix) Non-Disclosure Undertaking (The "Undertaking") of bidder {Attachment 7D} <p>NTPC shall not be liable for loss/non-receipt/late receipt of documents in postal transit.</p> <p>The copies of the EMD, Deed of Joint Undertaking of bidder and associate {Attachment 7C-1/7C-2/7C-3}, Non-Disclosure Undertaking (The "Undertaking") of bidder {Attachment 7D} & Power of Attorney should be uploaded in the collaboration Folder on line also. In case of vendors who are exempted from submitting EMD, the necessary documents shall be uploaded.</p>
	<p>ON-LINE {Clause 22.0 of GPC}</p>	<p>Under Attributes accept the following:</p> <ul style="list-style-type: none"> A. Certificate For Compliance To All Provisions Of Bidding Documents (Certificate of "NIL" Deviation) {Attachment 14} B. Acceptance of Fraud Prevention Policy {Attachment 15} C. Acceptance of Banning Policy {Attachment 16} D. Certificate of Compliance to QR {Attachment 21}

		<p>(*) Bidders may note that without Acceptance of above Attributes which are to be given online, Bidder will not be allowed to submit the bid.</p> <p>Bidders may note that without Acceptance of Attributes, Bidders will not be allowed to submit the bid.</p> <ul style="list-style-type: none"> • ON-LINE fill/submit the prices of all the items (Price Schedule) under Item Data Tab. Bid Price Scheduled (Schedule-1 to 4 and 6 to 7) (Excel file) and Attachment 1P & 2P dully filled to be uploaded in General Data through 'Attachment' link provided in "Unpriced Bid" tab. (Bidders may note that the Attachment (1P and 2P) and price schedule should not be uploaded in C Folder). • Under Unpriced bid in collaboration folder Upload the following: <table border="1" data-bbox="815 842 1495 1885"> <thead> <tr> <th></th> <th>File Name</th> <th>Contents</th> </tr> </thead> <tbody> <tr> <td>i.</td> <td>EMD</td> <td>Copy of EMD</td> </tr> <tr> <td>ii.</td> <td>MSE</td> <td>Valid NSIC / SSI certificate, if applicable, as required as per bid documents.</td> </tr> <tr> <td>iii.</td> <td>Power of Attorney</td> <td>Copy of Power of Attorney</td> </tr> <tr> <td>iv.</td> <td>QR</td> <td>Attachment 7A,7B-1 and 7B-2 of Volume I Section IV including dully filled annexure(s) and/or Appendix(s) and/or Attachments to Attachment 7A , 7B-1 and 7B-2</td> </tr> <tr> <td>v.</td> <td>QR Details</td> <td>All documents in support of meeting Qualifying Requirements.</td> </tr> <tr> <td>vi.</td> <td>Technical Specifications</td> <td>Technical specifications, Scope of Work, details & data sheets, drawings etc. in compliance to Technical specifications & Scope of Work.</td> </tr> </tbody> </table>		File Name	Contents	i.	EMD	Copy of EMD	ii.	MSE	Valid NSIC / SSI certificate, if applicable, as required as per bid documents.	iii.	Power of Attorney	Copy of Power of Attorney	iv.	QR	Attachment 7A,7B-1 and 7B-2 of Volume I Section IV including dully filled annexure(s) and/or Appendix(s) and/or Attachments to Attachment 7A , 7B-1 and 7B-2	v.	QR Details	All documents in support of meeting Qualifying Requirements.	vi.	Technical Specifications	Technical specifications, Scope of Work, details & data sheets, drawings etc. in compliance to Technical specifications & Scope of Work.
	File Name	Contents																					
i.	EMD	Copy of EMD																					
ii.	MSE	Valid NSIC / SSI certificate, if applicable, as required as per bid documents.																					
iii.	Power of Attorney	Copy of Power of Attorney																					
iv.	QR	Attachment 7A,7B-1 and 7B-2 of Volume I Section IV including dully filled annexure(s) and/or Appendix(s) and/or Attachments to Attachment 7A , 7B-1 and 7B-2																					
v.	QR Details	All documents in support of meeting Qualifying Requirements.																					
vi.	Technical Specifications	Technical specifications, Scope of Work, details & data sheets, drawings etc. in compliance to Technical specifications & Scope of Work.																					

			vii.	Compliance to Technical Specifications	Details of Compliance to Technical Specifications & Scope of work (Volume III).
			viii.	Attachment 10	Milestone Schedule.
			ix.	Attachment 12	EFT Form
			x.	Others	Any other document to establish compliance to the Bidding Document
			xi.	Attachment 7C-1/7C-2/7C-3	Deed Of Joint Undertaking of bidder and associate
			xii.	Attachment 7D	Non-Disclosure Undertaking (The "Undertaking") of bidder
			xiii.	Client certificate	Client certificates stating that that bidder is meeting all requirement of as per QR.
			xiv.	Any other documents	
		<p>Bidders may note that no price component is to be uploaded in the collaboration -folder.</p> <p>NOTE: Bidders are requested NOT to upload zip files in the c-folder.</p>			
53.0	SIGNING OF ON LINE BIDS	<p>The on-line bid is to be digitally signed using a valid Class III digital certificate (in the name of designated individual with Organization name) as per Indian IT Act from the licensed Certifying Authorities (CA) operating under the Root Certifying Authority of India (RCAI) namely Controller of Certifying Authorities (CCA) of India, failing which the bid shall be rejected.</p>			

<p>54.0</p>	<p>LOSS OF OR DAMAGE TO PROPERTY; ACCIDENT OR INJURY TO WORKERS; INDEMNIFICATION</p>	<p>54.1 The Contractor shall indemnify and hold harmless the Employer and its employees and officers from and against any and all suits, actions or administrative proceedings, claims, demands, losses, damages, costs, and expenses of whatsoever nature, including attorney's fees and expenses, in respect of the death or injury of any person or loss of or damage to any property (other than the Facilities whether accepted or not), arising in connection with the supply and installation of the Facilities and by reason of the negligence of the Contractor or its Subcontractors, or their employees, officers or agents, except any injury, death or property damage caused by the negligence of the Employer, its contractors, employees, officers or agents.</p> <p>54.2 If any proceedings are brought or any claim is made against the Employer that might subject the Contractor to liability under GCC Sub-Clause 54.1, the Employer shall promptly give the Contractor a notice thereof and the Contractor may at its own expense and in the Employer's name conduct such proceedings or claim and any negotiations for the settlement of any such proceedings or claim.</p> <p>If the Contractor fails to notify the Employer within twenty-eight (28) days after receipt of such notice that it intends to conduct any such proceedings or claim, then the Employer shall be free to conduct the same on its own behalf. Unless the Contractor has so failed to notify the Employer within the twenty-eight (28) day period, the Employer shall make no admission that may be prejudicial to the defence of any such proceedings or claim.</p> <p>The Employer shall, at the Contractor's request, afford all available assistance to the Contractor in conducting such proceedings or claim, and shall be reimbursed by the Contractor for all reasonable expenses incurred in so doing.</p>
<p>55.0</p>	<p>ASSIGNEE OF FOREIGN BIDDER</p>	<p>The Foreign bidder, however, has the option, to be exercised as a part of its bid proposal, to propose an Assignee in its bid to execute the Second Contract and/or the Third Contract. For the scope of work envisaged by the foreign bidder, in its bid, to be executed by Assignee, the Assignee should have relevant/required capacity and experience of executing similar job. The bidder shall substantiate with relevant/required documents in the bid to establish capacity and experience of the Assignee.</p> <p>If the Foreign bidder has proposed an Assignee in its bid to execute the Second Contract and/or the Third Contract and has also furnished written unequivocal consent of the proposed Assignee to work as an independent Bidder on</p>

		<p>the terms and conditions offered by the bidder and if the Employer is satisfied with the capacity and experience of the Assignee proposed in the bid, the Employer will enter into the 'Second Contract' and/or the 'Third Contract' with the Assignee. However, if the Employer in its judgement does not find acceptance of the Assignee proposed in the bid as its Bidder, then on the request of the Employer, the bidder shall have option to propose an alternate Assignee on the same terms and conditions and cost as offered in its bid. It is expressly understood and agreed that in case the option is not exercised by the Bidder or if the Assignee fails to enter into Contract(s) with the Employer or if the Employer in its judgement does not find acceptance of the Assignee as its Bidder, then the foreign bidder shall be obliged to enter into and execute all the three Contracts with the Employer covering the entire scope of work envisaged in the bidding documents on the same terms and conditions and cost as offered in its bid.</p> <p>However, for the above purpose, only one Assignee shall be permitted for both Second Contract and/or Third Contract.</p> <p>Within 30 days of placement of award, the successful Assignee of foreign bidder (if applicable) shall sign and date the Contract Agreement and return it to the Employer. Cost of preparing Contract Agreement shall be borne by the Bidder.</p> <p>In case of a successful foreign bidder, if the Employer accepts to enter into the Second Contract and / or Third Contract with the Assignee, pursuant to above, then, within 30 days of placement of award, the Assignee shall furnish additional performance security(ies) for ten percent (10%) of the value of the Contract(s) entered into with the Assignee and in the form provided in the Section "Forms and Procedures" of the bidding documents.</p> <p>The Employer also reserves the right to assess the capacity and capability of the bidder/collaborator/proposed assignee to satisfactorily execute the contract. Such assessment may include but not limited to the evaluation of adequacy of facilities services, resources, design/engineering capacity & financial capability. The credentials of Assignee to be submitted with the Bid.</p> <p>Power of attorney(s), duly notarized by Notary Public, indicating that the person(s) signing the documents on behalf of Assignee (s) have the authority to sign the same and the said documents are binding upon them during the full period of its validity.</p>
--	--	---

<p>56.0</p>	<p>SIGNING OF CONTRACT AGREEMENT {Clause 34.0 of GPC Volume I Section II }</p>	<p>The clause may be read as under: At the same time as the Employer notifies the successful Bidder that its bid has been accepted, the Employer will send to the Bidder the Contract Agreement provided in the bidding documents, incorporating all agreements between the parties. Within 30 days of receipt of the Contract Agreement, the successful Bidder / Assignee of foreign bidder (if applicable) shall sign and date the Contract Agreement and return it to the Employer.</p>
<p>57.0</p>	<p>Completion of the Facilities</p>	<p>Completion of the Facilities 57.1 As soon as all works in respect of Pre-commissioning are completed and, in the opinion of the Contractor, the Facilities or any part thereof is ready for Commissioning, the Contractor shall commence Commissioning as per procedures stipulated in Technical Specifications, and as soon as Commissioning is satisfactorily completed, the Contractor shall so notify the Project Manager in writing. 57.2 The Project Manager shall, within fourteen (14) days after receipt of the Contractor's notice under Clause 57.1 of SPC, either issue a Completion Certificate in the form specified in the Forms and Procedures section in the bidding documents, stating that the Facilities or that part thereof have reached Completion as at the date of the Contractor's notice under Clause 57.1 of SPC, or notify the Contractor in writing of any defects and/or deficiencies. If the Project Manager notifies the Contractor of any defects and/or deficiencies, the Contractor shall then correct such defects and/or deficiencies, and shall repeat the procedure described in Clause 57.1 of SPC. If the Project Manager is satisfied that the Facilities or that part thereof have reached Completion, the Project Manager shall, within seven (7) days after receipt of the Contractor's repeated notice, issue a Completion Certificate stating that the Facilities or that part thereof have reached Completion as at the date of the Contractor's repeated notice. If the Project Manager is not so satisfied, then it shall notify the Contractor in writing of any defects and/or deficiencies within seven (7) days after receipt of the Contractor's repeated notice, and the above procedure shall be repeated. 57.3 If the Project Manager fails to issue the Completion Certificate and fails to inform the Contractor of any</p>

		<p>defects and/or deficiencies within fourteen (14) days after receipt of the Contractor's notice under Clause 57.1 of SPC or within seven (7) days after receipt of the Contractor's repeated notice under Clause 57.2 of SPC, or if the Employer makes use of the Facilities or part thereof, then the Facilities or that part thereof shall be deemed to have reached Completion as of the date of the Contractor's notice or repeated notice, or as of the Employer's use of the Facilities, as the case may be.</p> <p>57.4 As soon as possible after Completion, the Contractor shall complete all outstanding minor items so that the Facilities are fully in accordance with the requirements of the Contract, failing which the Employer will undertake such completion and deduct the costs thereof from any monies owing to the Contractor.</p> <p>57.5 Upon Completion, the Employer shall be responsible for the care and custody of the Facilities or the relevant part thereof, together with the risk of loss or damage thereto, and shall thereafter take over the Facilities or the relevant part thereof.</p>
<p>58.0</p>	<p>Commissioning, SAT and Operational Acceptance</p>	<p>Commissioning, SAT Test and Operational Acceptance</p> <p>58.1 Commissioning</p> <p>58.1.1 Commissioning of the Facilities or any part thereof shall be completed by the Contractor as per procedures detailed in the Technical Specifications.</p> <p>58.2 SAT Test</p> <p>58.2.1 The SAT (and repeats thereof) shall be conducted by the Contractor after Commissioning of the Facilities or the relevant part thereof to ascertain whether the Facilities or the relevant part can attain the Minimum Improvement Figure specified in clause no 10.0 of Volume III - Technical specifications and scope of work. The Contractor's and Project Manager's advisory personnel shall attend the SAT. The Employer shall promptly provide the Contractor with such information as the Contractor may reasonably require in relation to the conduct and results of the SAT (and any repeats thereof).</p> <p>58.3 Operational Acceptance</p> <p>58.3.1 Subject to GCC Sub-Clause 58.4 (Partial Acceptance) below, Operational Acceptance shall occur in respect of the Facilities or any part thereof when</p> <p>a) the SAT has been successfully completed and the Minimum Improvement Figure specified in clause no 10.0 of Volume III - Technical</p>

		<p>specifications and scope of work are met; or</p> <p>b) the Contractor has paid the deduction of payment as per payment terms specified in clause no 39.0 of SPC and forfeit of CPG, if applicable as per clause 8.13 of Volume III - Technical specifications and scope of work ; and</p> <p>c) any minor items mentioned in Clause 57.4 of SPC hereof relevant to the Facilities or that part thereof have been completed.</p> <p>58.3.2 At any time after any of the events set out in Clause 58.3.1 of SPC have occurred, the Contractor may give a notice to the Project Manager requesting the issue of an Operational Acceptance Certificate in the form provided in the Bidding Documents or in another form acceptable to the Employer in respect of the Facilities or the part thereof specified in such notice as at the date of such notice.</p> <p>58.3.3 The Project Manager shall, after consultation with the Employer, and within forty five (45) days after receipt of the Contractor’s notice, issue an Operational Acceptance Certificate.</p> <p>58.3.4 If within forty five (45) days after receipt of the Contractor’s notice, the Project Manager fails to issue the Operational Acceptance Certificate or fails to inform the Contractor in writing of the justifiable reasons why the Project Manager has not issued the Operational Acceptance Certificate, the Facilities or the relevant part thereof shall be deemed to have been accepted as at the date of the Contractor’s said notice.</p> <p>58.4 Partial Acceptance</p> <p>58.4.1 If the Contract specifies that Completion and Commissioning shall be carried out in respect of parts of the Facilities, the provisions relating to Completion and Commissioning including the SAT shall apply to each such part of the Facilities individually, and the Operational Acceptance Certificate shall be issued accordingly for each such part of the Facilities.</p>
<p>59.0</p>	<p>Completion Time Guarantee</p>	<p>Completion Time Guarantee</p> <p>59.1 The Contractor guarantees that it shall attain Completion of the Facilities (or a part for which a separate time for completion is specified in the SCC)</p>

		<p>within the Time for Completion specified in clause 7.0 of Volume III - Technical specifications and scope of work, or within such extended time to which the Contractor shall be awarded (Extension of Time for Completion) hereof.</p>
<p>60.0</p>	<p>Defect Liability</p>	<p>Defect Liability</p> <p>60.1 The Contractor warrants that the Facilities or any part thereof shall be free from defects in the design, engineering, materials and workmanship of the Plant and Equipment supplied and of the work executed.</p> <p>60.2 The Defect Liability Period shall be eighteen (18) months from the date of Completion of the Facilities (or any part thereof) or twelve (12) months from the date of Operational Acceptance of the Facilities (or any part thereof), whichever first occurs, unless specified otherwise in the SCC.</p> <p>If during the Defect Liability Period any defect should be found in the design, engineering, materials and workmanship of the Plant and Equipment supplied or of the work executed by the Contractor, the Contractor shall promptly, in consultation and agreement with the Employer regarding appropriate remedying of the defects, and at its cost, repair, replace or otherwise make good (as the Contractor shall, at its discretion, determine) such defect as well as any damage to the Facilities caused by such defect. The Contractor shall not be responsible for the repair, replacement or making good of any defect or of any damage to the Facilities arising out of or resulting from any of the following causes:</p> <ul style="list-style-type: none"> a) improper operation or maintenance of the Facilities by the Employer b) operation of the Facilities outside specifications provided in the Contract c) normal wear and tear. <p>60.3 The Contractor's obligations under this SPC Clause 60 shall not apply to</p> <ul style="list-style-type: none"> a) any materials that are supplied by the Employer, are normally consumed in operation, or have a normal life shorter than the Defect Liability Period stated herein b) any designs, specifications or other data designed, supplied or specified by or on behalf of the Employer or any matters for which the

		<p>Contractor has disclaimed responsibility herein</p> <p>c) any other materials supplied or any other work executed by or on behalf of the Employer, except for the work executed by the Employer.</p> <p>60.4 The Employer shall give the Contractor a notice stating the nature of any such defect together with all available evidence thereof, promptly following the discovery thereof. The Employer shall afford all reasonable opportunity for the Contractor to inspect any such defect.</p> <p>60.5 The Employer shall afford the Contractor all necessary access to the Facilities and the Site to enable the Contractor to perform its obligations. The Contractor may, with the consent of the Employer, remove from the Site any Plant and Equipment or any part of the Facilities that are defective if the nature of the defect, and/or any damage to the Facilities caused by the defect, is such that repairs cannot be expeditiously carried out at the Site.</p> <p>60.6 If the repair, replacement or making good is of such a character that it may affect the efficiency of the Facilities or any part thereof, the Employer may give to the Contractor a notice requiring that tests of the defective part of the Facilities shall be made by the Contractor immediately upon completion of such remedial work, whereupon the Contractor shall carry out such tests. If such part fails the tests, the Contractor shall carry out further repair, replacement or making good (as the case may be) until that part of the Facilities passes such tests. The tests in character shall in any case be not less than what has already been agreed by the Employer and the Contractor for the original equipment/part of the Facilities.</p> <p>60.7 If the Contractor fails to commence the work necessary to remedy such defect or any damage to the Facilities caused by such defect within a reasonable time (which shall in no event be considered to be less than fifteen (15) days), the Employer may, following notice to the Contractor, proceed to do such work, and the reasonable costs incurred by the Employer in connection therewith shall be paid to the Employer by the Contractor or may be deducted by the Employer from any monies due to the Contractor or claimed under the Performance Security.</p> <p>60.8 If the Facilities or any part thereof cannot be used by</p>
--	--	---

		<p>reason of such defect and/or making good of such defect, the Defect Liability Period of the Facilities or such part, as the case may be, shall be extended by a period equal to the period during which the Facilities or such part cannot be used by the Employer because of any of the aforesaid reasons. Upon correction of the defects in the Facilities or any part thereof by repair/replacement, such repair/replacement shall have the Defect Liability Period extended by a period of twelve (12) month from the time such replacement/repair of the Facilities or any part thereof.</p> <p>60.8.1 At the end of the Defect Liability Period, the contractor liability ceases except for latent defects. The contractor's liability for latent defects warranty shall be limited to a period of five (5) years from the end of Defect Liability Period. For the purpose of the this clause, the latent defects shall be the defects inherently lying within the material or arising out of design deficiency which do not manifest themselves during the Defect Liability Period in this SPC clause 60, but later.</p> <p>60.9 Except as provided in Clauses 54.0 of SPC (Loss of or Damage to Property / Accident or Injury to Workers/Indemnification), the Contractor shall be under no liability whatsoever and howsoever arising, and whether under the Contract or at law, in respect of defects in the Facilities or any part thereof, the Plant and Equipment, design or engineering or work executed that appear after Completion of the Facilities or any part thereof, except where such defects are the result of the gross negligence, fraud, criminal or willful action of the Contractor.</p> <p>60.10 In addition, the Contractor shall also provide an extended warranty for any such component of the Facilities and during the period of time as may be specified in the SPC. Such obligation shall be in addition to the defect liability specified under Clause 60.2 of SPC.</p>
<p>61.0</p>	<p>Minimum Improvement Figure</p>	<p>Minimum Improvement Figure</p> <p>61.1 The Contractor guarantees that during the SAT, the Facilities and all parts thereof shall attain the Minimum Improvement Figure specified in clause no 10.0 of Volume III - Technical specifications and scope of work, subject to and upon the conditions therein specified.</p> <p>61.2 If, for reasons attributable to the Contractor, the</p>

		<p>guaranteed level of the Minimum Improvement Figure specified in clause no 10.0 of Volume III - Technical specifications and scope of work are not met either in whole or in part, the Contractor shall, within a mutually agreed time, at its cost and expense make such changes, modifications and/or additions to the Plant or any part thereof as may be necessary to meet such Guarantees. The Contractor shall notify the Employer upon completion of the necessary changes, modifications and/or additions, and shall seek the Employer's consent to repeat the SAT. If the specified Minimum Improvement Figure specified in clause no 10.0 of Volume III - Technical specifications and scope of work are not established even during the repeat of the SAT, the Employer may at its option, either</p> <ul style="list-style-type: none"> a) Reject the Equipment and recover the payments already made, or b) Terminate the Contract pursuant to clause 57.0 of GPC and recover the payments already made, or c) Accept the equipment after deduction of payment as per payment terms specified in clause no 39.0 of SPC and forfeit of CPG, if applicable as per clause 8.13 of Volume III - Technical specifications and scope of work. <p>61.3 In case the Employer exercises its option to accept the equipment after deduction of payment as per payment terms specified in clause no 39.0 of SPC and forfeit of CPG, if applicable as per clause 8.13 of Volume III - Technical specifications and scope of work, the deduction of payment as per payment terms specified in clause no 39.0 of SPC and forfeit of CPG, if applicable as per clause 8.13 of Volume III - Technical specifications and scope of work, shall completely satisfy the Contractor's guarantees, and the Contractor shall have no further liability whatsoever to the Employer in respect thereof. Upon the deduction of payment as per payment terms specified in clause no 39.0 of SPC and forfeit of CPG, if applicable as per clause 8.13 of Volume III - Technical specifications and scope of work, the Project Manager shall issue the Operational Acceptance Certificate for the Facilities or any part thereof in respect of which the liquidated damages have been so paid.</p>
--	--	--

62.0	PRE-BID CONFERENCE	<p>The Bidder or his authorised representative is invited to attend the pre-bid conference which will take place at the following address:</p> <p>NTPC LTD., EOC, Plot no. A-8A, Sector 24, NOIDA(UP),India-201 301</p> <p>The pre-bid conference shall be arranged on the date and time specified in the NIT.</p> <p>The purpose of the conference will be to clarify any issue regarding the Bidding Documents.</p> <p>The Bidder is required to submit questions in writing or by fax to reach the Employer at the Employer's mailing address indicated above, not later than the Pre-Bid Conference.</p> <p>Record Notes of the conference including the Employer's responses to the queries raised by the bidders in writing shall be transmitted to all the prospective bidders who have purchased the bidding documents. Further, any modifications of the bidding documents which may become necessary as a result of the pre-bid conference shall be made by the Employer exclusively through an amendment to the bidding documents and not through the record notes of the pre-bid conference.</p> <p>Non attendance at the Pre-Bid Conference will not be a cause for disqualification of a bidder.</p>	
63.0	Non-Disclosure Undertaking (the "Undertaking")	<p>NTPC shall provide available historical data of the APC related tags of last one year to the Bidder after the Bidder signs and submits a Non-Disclosure Undertaking (the "Undertaking") on non-judicial stamp paper of appropriate value for ensuring the confidentiality of work, information and all documents that will be exchanged. The Non-Disclosure Undertaking (the "Undertaking") shall be signed by the authorised signatory of the Contractor as per format enclosed in the bidding document.</p>	
64.0	CONTACT PERSONS / ADDRESS	<p>Addl. General Manager (CM) NTPC LTD., 6TH FLOOR, EOC, Plot no. A-8A, Sector 24 NOIDA(UP),India-201 301</p>	<p>DGM (CM) NTPC LTD., 6th Floor, EOC, Plot no. A-8A, Sector 24 NOIDA(UP),India-201 301</p>
	E mail ID	<p>rckhorwal@ntpc.co.in</p>	<p>sandeepdatta@ntpc.co.in</p>
	Telephone	<p>0120- 4946625/2410477</p>	<p>0120 – 4948624</p>
	Fax	<p>0120- 2410026</p>	



Special Purchase Conditions – e-tendering for Reverse Auction Part - B

NOT APPLICABLE

Amendment no. 1 to for NIT No : 40086783

Sl. No.	Reference	Description as mentioned in Bidding Document	Description to be Read as																
1.	Volume-II Section-I Special Purchase Conditions 25.0 BID PRICES	<p>Bidders shall quote for the entire scope on a "single responsibility" basis, such that the total bid price (per Unit) covers all the Contractor's obligations mentioned in or to be reasonably inferred from the bidding documents in respect of the design, manufacture, including procurement and subcontracting (if any), delivery.</p> <p>Bidders are required to quote the price (per Unit) for the commercial, contractual and technical obligations outlined in the bidding documents.</p> <p>Following schedules are to be filled up (per Unit):</p> <table border="1" data-bbox="611 781 1241 1209"> <tr> <td>Schedule-1</td> <td>Items/ Hardware and software to be supplied from Abroad (per Unit).</td> </tr> <tr> <td>Schedule-2</td> <td>Items/ Hardware and software to be supplied from within the Employer's Country (per Unit).</td> </tr> <tr> <td>Schedule-3</td> <td>Local Transportation including Port handling, Port clearance, Port charges, Inland insurance and other local costs incidental to delivery of Items/ Hardware and software (per Unit).</td> </tr> <tr> <td>Schedule-4</td> <td>Installation Services, Training ,</td> </tr> </table>	Schedule-1	Items/ Hardware and software to be supplied from Abroad (per Unit).	Schedule-2	Items/ Hardware and software to be supplied from within the Employer's Country (per Unit).	Schedule-3	Local Transportation including Port handling, Port clearance, Port charges, Inland insurance and other local costs incidental to delivery of Items/ Hardware and software (per Unit).	Schedule-4	Installation Services, Training ,	<p>Bidders shall quote for the entire scope on a "single responsibility" basis, such that the total bid price (per Unit) covers all the Contractor's obligations mentioned in or to be reasonably inferred from the bidding documents in respect of the design, manufacture, including procurement and subcontracting (if any), delivery.</p> <p>Bidders are required to quote the price (per Unit) for the commercial, contractual and technical obligations outlined in the bidding documents.</p> <p>Following schedules are to be filled up (per Unit):</p> <table border="1" data-bbox="1308 781 1938 1209"> <tr> <td>Schedule-1</td> <td>Items/ Hardware and software to be supplied from Abroad (per Unit).</td> </tr> <tr> <td>Schedule-2</td> <td>Items/ Hardware and software to be supplied from within the Employer's Country (per Unit).</td> </tr> <tr> <td>Schedule-3</td> <td>Local Transportation including Port handling, Port clearance, Port charges, Inland insurance and other local costs incidental to delivery of Items/ Hardware and software (per Unit).</td> </tr> <tr> <td>Schedule-</td> <td>Installation Services, Training ,</td> </tr> </table>	Schedule-1	Items/ Hardware and software to be supplied from Abroad (per Unit).	Schedule-2	Items/ Hardware and software to be supplied from within the Employer's Country (per Unit).	Schedule-3	Local Transportation including Port handling, Port clearance, Port charges, Inland insurance and other local costs incidental to delivery of Items/ Hardware and software (per Unit).	Schedule-	Installation Services, Training ,
Schedule-1	Items/ Hardware and software to be supplied from Abroad (per Unit).																		
Schedule-2	Items/ Hardware and software to be supplied from within the Employer's Country (per Unit).																		
Schedule-3	Local Transportation including Port handling, Port clearance, Port charges, Inland insurance and other local costs incidental to delivery of Items/ Hardware and software (per Unit).																		
Schedule-4	Installation Services, Training ,																		
Schedule-1	Items/ Hardware and software to be supplied from Abroad (per Unit).																		
Schedule-2	Items/ Hardware and software to be supplied from within the Employer's Country (per Unit).																		
Schedule-3	Local Transportation including Port handling, Port clearance, Port charges, Inland insurance and other local costs incidental to delivery of Items/ Hardware and software (per Unit).																		
Schedule-	Installation Services, Training ,																		

Amendment no. 1 to for NIT No : 40086783

Sl. No.	Reference	Description as mentioned in Bidding Document		Description to be Read as	
			Handholding and Tuning services ,SAT, Insurance covers other than inland transit insurance and other services as specified in the bidding documents (per Unit).	4	Handholding and Tuning services ,SAT, Insurance covers other than inland transit insurance and other services as specified in the bidding documents (per Unit).
		Schedule-5	Not applicable	Schedule-5	Not applicable
		Schedule -6	<u>Taxes and Duties, applicable on Ex-works (India) price component (Schedule-2), not included in bid price (per Unit).</u>	Schedule -6	<u>Goods and Services Tax (GST), applicable on Schedules - 2, 3 & 4, not included in bid price (per Unit).</u>
		Schedule -7	<u>Break up of different taxes including GST included in the price quoted in schedule 3 & 4 against different items (per Unit).</u>	Schedule -7	<u>NOT USED</u>
		Schedule -8	The details of supply of Item/Equipment and Mandatory Spares and services which are under Reverse Charge Mechanism as per GST act and included in schedule 1,2,3 &4 (per Unit).	Schedule -8	The details of supply of Item/Equipment and Mandatory Spares and services which are under Reverse Charge Mechanism as per GST act and included in schedule 1,2,3 &4 (per Unit).
		In the Schedules, Bidders shall give the required details and		<p>In the Schedules, Bidders shall give the required details and a breakdown of their prices (per Unit) as follows:</p> <p>iii. Schedule No. 1 Items/ Hardware and software to be</p>	

Amendment no. 1 to for NIT No : 40086783

Sl. No.	Reference	Description as mentioned in Bidding Document	Description to be Read as
		<p>a breakdown of their prices (per Unit) as follows:</p> <p>i. Schedule No. 1 Items/ Hardware and software to be supplied from Abroad (per Unit)</p> <p>Schedule No.1 items shall be quoted on CIF (Indian port-of-entry) basis.</p> <p>Further, Bidders seeking qualification on the basis of association with manufacturer(s) of particular Items/ Hardware and software (s) are required to quote the price of such Items/ Hardware and software (s) including spares on CIF (Indian port-of-entry) basis, if the items are to be imported by the manufacturer or the bidder. In case, such Items/Hardware and software and spares are not quoted by the bidder on CIF (Indian port-of-entry) basis, then EMPLOYER shall assess the CIF (Indian port-of-entry) price of such Items/ Hardware and software for the purpose of evaluation.</p> <p>Notwithstanding GPC Sub 58.0, the Employer shall bear and promptly pay custom duty as well as GST on Imports and any other tax/duty/levy, imposed on the Item/Equipment and Mandatory Spares specified in Price Schedule No. 1 (and on recommendatory spares</p>	<p>supplied from Abroad (per Unit)</p> <p>Schedule No.1 items shall be quoted on CIF (Indian port-of-entry) basis.</p> <p>Further, Bidders seeking qualification on the basis of association with manufacturer(s) of particular Items/ Hardware and software (s) are required to quote the price of such Items/ Hardware and software (s) including spares on CIF (Indian port-of-entry) basis, if the items are to be imported by the manufacturer or the bidder. In case, such Items/Hardware and software and spares are not quoted by the bidder on CIF (Indian port-of-entry) basis, then EMPLOYER shall assess the CIF (Indian port-of-entry) price of such Items/ Hardware and software for the purpose of evaluation.</p> <p>Notwithstanding GPC Sub 58.0, the Employer shall bear and promptly pay custom duty as well as GST on Imports and any other tax/duty/levy, imposed on the Item/Equipment and Mandatory Spares specified in Price Schedule No. 1 (and on recommendatory spares part to be supplied from abroad and specified in Schedule No. 5, when awarded) and that are to be incorporated into the Facilities by the law of the country where the Site is located. Further, the Bidder</p>

Amendment no. 1 to for NIT No : 40086783

Sl. No.	Reference	Description as mentioned in Bidding Document	Description to be Read as
		<p>part to be supplied from abroad and specified in Schedule No. 5, when awarded) and that are to be incorporated into the Facilities by the law of the country where the Site is located. Further, the Bidder is advised to source the Item/Equipment and Mandatory Spares including Mandatory Spares/ Recommended Spares from territories which do not attract additional duties under Customs like Anti-dumping duty (Section 9A to Custom Tariff Act), Counter-vailing duty on subsidised articles (Section 9 to Custom Tariff Act), Safeguard duty (Section 8A, 8B, 8C to Custom Tariff Act) etc. In case any such additional duties under Customs is imposed on Item/Equipment and Mandatory Spares including Mandatory Spares/ Recommended Spares, the same shall be borne and paid/reimbursed by the Bidder.</p> <p>However, if the local laws require such payment of the custom duty or GST to be made by the Bidder, the same shall be reimbursed to the Bidder on production of satisfactory evidence of having paid the custom duty or GST amount to the concerned authorities</p> <p>ii. Schedule No. 2: Items/ Hardware and software to be supplied from within the Employer's Country (per Unit)</p>	<p>is advised to source the Item/Equipment and Mandatory Spares including Mandatory Spares/ Recommended Spares from territories which do not attract additional duties under Customs like Anti-dumping duty (Section 9A to Custom Tariff Act), Counter-vailing duty on subsidised articles (Section 9 to Custom Tariff Act), Safeguard duty (Section 8A, 8B, 8C to Custom Tariff Act) etc. In case any such additional duties under Customs is imposed on Item/Equipment and Mandatory Spares including Mandatory Spares/ Recommended Spares, the same shall be borne and paid/reimbursed by the Bidder.</p> <p>However, if the local laws require such payment of the custom duty or GST to be made by the Bidder, the same shall be reimbursed to the Bidder on production of satisfactory evidence of having paid the custom duty or GST amount to the concerned authorities</p> <p>iv. Schedule No. 2: Items/ Hardware and software to be supplied from within the Employer's Country (per Unit)</p> <p><u>Schedule No. 2 items shall be quoted on EXW (ex-factory, ex-works, ex-warehouse or off-the-shelf, as applicable) basis and shall be inclusive of all costs as</u></p>

Amendment no. 1 to for NIT No : 40086783

Sl. No.	Reference	Description as mentioned in Bidding Document	Description to be Read as
		<p><u>Schedule No. 2 items shall be quoted on EXW (exfactory, ex-works, ex-warehouse or off- the-shelf, as applicable) basis and shall be inclusive of all costs as well as taxes, duties and levies (including GST considering ITC benefit) paid or payable on components and raw materials incorporated or to be incorporated in the facilities.</u></p> <p>Further, the prices for Mandatory Spares shall be quoted in compliance with the requirements as per the list of Mandatory Spares specified in the Technical Specifications and the Price Schedule-2 of the Bidding documents.</p> <p>However, GST and any other tax/duty/levy applicable in respect of direct transactions between the Employer and the Bidder/ Assignee of Foreign Bidder (if applicable) and on Bought out Items (to be dispatched directly from the subvendor's works to Project Site) shall not be included in the Ex-Works price, but shall be quoted separately in Schedule No. 6.</p> <p>GST and other applicable tax/duty/levy quoted by the bidder in Schedule No. 6 shall be as applicable in the Employer's country as on seven (7) days prior to the</p>	<p><u>well as duties and taxes paid or payable on components and raw materials incorporated or to be incorporated in the facilities.</u></p> <p>Further, the prices for Mandatory Spares shall be quoted in compliance with the requirements as per the list of Mandatory Spares specified in the Technical Specifications and the Price Schedule-2 of the Bidding documents.</p> <p>However, GST and any other tax/duty/levy applicable in respect of direct transactions between the Employer and the Bidder/ Assignee of Foreign Bidder (if applicable) and on Bought out Items (to be dispatched directly from the subvendor's works to Project Site) shall not be included in the Ex-Works price, but shall be quoted separately in Schedule No. 6.</p> <p>GST and other applicable tax/duty/levy quoted by the bidder in Schedule No. 6 shall be as applicable in the Employer's country as on seven (7) days prior to the deadline for submission of Price Bids.</p> <p>The Employer shall also bear and pay/reimburse to the Bidder /Assignee of Foreign Bidder (if applicable) GST and any other tax/duty/levy in respect of both direct transactions between the Employer and the</p>

Amendment no. 1 to for NIT No : 40086783

Sl. No.	Reference	Description as mentioned in Bidding Document	Description to be Read as
		<p>deadline for submission of Price Bids.</p> <p>The Employer shall also bear and pay/reimburse to the Bidder /Assignee of Foreign Bidder (if applicable) GST and any other tax/duty/levy in respect of both direct transactions between the Employer and the Bidder /Assignee of Foreign Bidder (if applicable) and on Bought out items (to be dispatched directly from the subvendor's works to Project Site), if imposed on the Items and Mandatory Spares specified in Price Schedule No. 2 (and also on locally supplied recommendatory Spares quoted in Schedule No. 5, when awarded) to be incorporated in the Package, by the law of country where the Site is located.</p> <p>Due Input Tax credits under GST as per the relevant Govt. Policy, wherever applicable, shall be taken into account by the Bidder while quoting his prices.</p> <p>iii. Schedule No. 3: Local Transportation including Port handling, Port clearance, Port charges, Inland insurance and other local costs incidental to delivery of Items/ Hardware and software (per Unit).</p> <p><u>Local Transportation including Port handling, Port clearance, Port charges, Inland insurance and other</u></p>	<p>Bidder /Assignee of Foreign Bidder (if applicable) and on Bought out items (to be dispatched directly from the subvendor's works to Project Site), if imposed on the Items and Mandatory Spares specified in Price Schedule No. 2 (and also on locally supplied recommendatory Spares quoted in Schedule No. 5, when awarded) to be incorporated in the Package, by the law of country where the Site is located.</p> <p>Due Input Tax credits under GST as per the relevant Govt. Policy, wherever applicable, shall be taken into account by the Bidder while quoting his prices.</p> <p>ix. Schedule No. 3: Local Transportation including Port handling, Port clearance, Port charges, Inland insurance and other local costs incidental to delivery of Items/ Hardware and software (per Unit).</p> <p><u>Local Transportation including Port handling, Port clearance, Port charges, Inland insurance and other local costs incidental to delivery of Items/ Hardware and software. Local Transportation, Inland Transit Insurance, Port Clearance, Port Handling and Port Charges, Custom reconciliation and other local costs incidental to delivery of the Items/ Hardware and software shall be quoted in Schedule-3 be inclusive</u></p>

Amendment no. 1 to for NIT No : 40086783

Sl. No.	Reference	Description as mentioned in Bidding Document	Description to be Read as
		<p><u>local costs incidental to delivery of Items/ Hardware and software. Local Transportation, Inland Transit Insurance, Port Clearance, Port Handling and Port Charges, Custom reconciliation and other local costs incidental to delivery of the Items/ Hardware and software shall be quoted in Schedule-3 inclusive of all taxes / duties / levies & charges including GST, if any for supply of such services payable in the Employer's country as on 7 days prior to the deadline for submission of Price Bid. The Employer shall be responsible and be liable only for payment of Customs Duty and GST and any other tax/duty/levy on Imports on CIF (Indian Port of Entry) component of the Items/Hardware and software to be supplied from abroad quoted in Schedule No. 1. However, the Employer, as a consignee shall furnish promptly necessary clarifications and documents as may be required to be furnished by the consignee for the purpose of customs clearance.</u></p> <p>Notwithstanding anything stated above, in case of services covered under Reverse Charge Mechanism, bidder shall quote only basic price for said service and for evaluation the bid of Supplier of Services shall be cost compensated as per the GST rate applicable as per GST Law.</p>	<p><u>of all Taxes, Duties, Levies & charges, except Goods and Services Tax (GST), payable in the Employer's country as of seven (7) days prior to the deadline for submission of price bids. The Employer shall be responsible and be liable only for payment of Customs Duty and GST and any other tax/duty/levy on Imports on CIF (Indian Port of Entry) component of the Items/Hardware and software to be supplied from abroad quoted in Schedule No. 1. However, the Employer, as a consignee shall furnish promptly necessary clarifications and documents as may be required to be furnished by the consignee for the purpose of customs clearance.</u></p> <p>Notwithstanding anything stated above, in case of services covered under Reverse Charge Mechanism, bidder shall quote only basic price for said service and for evaluation the bid of Supplier of Services shall be cost compensated as per the GST rate applicable as per GST Law.</p> <p>Due Input Tax credits under GST as per the relevant Govt. Policy, wherever applicable, shall be taken into account by the Bidder while quoting his prices.</p> <p>x. Schedule No. 4: Installation Services, Training ,</p>

Amendment no. 1 to for NIT No : 40086783

Sl. No.	Reference	Description as mentioned in Bidding Document	Description to be Read as
		<p>Due Input Tax credits under GST as per the relevant Govt. Policy, wherever applicable, shall be taken into account by the Bidder while quoting his prices.</p> <p>iv. Schedule No. 4: Installation Services, Training, Handholding and Tuning services, SAT, Insurance covers other than inland transit insurance and other services as specified in the bidding documents (per Unit).</p> <p><u>Installation Services including Erection and Civil & Allied Works (as applicable) shall be quoted separately (Schedule No. 4) and shall include rates or prices for all labour, Bidder's equipment, temporary works, materials, consumables and all matters and things of whatsoever nature, charges for insurance covers other than inland transit Insurance including operations and maintenance services, the provision of operations and maintenance manuals, training of employer's personnel, etc., and other supply of services, as identified in the Bidding Documents, as necessary for the proper execution/supply of the Installation Services. The prices quoted in Schedule No. 4 shall be inclusive of all Taxes, Duties, Levies and Charges including GST payable in the Employer's</u></p>	<p>Handholding and Tuning services, SAT, Insurance covers other than inland transit insurance and other services as specified in the bidding documents (per Unit).</p> <p><u>Installation Services including Erection and Civil & Allied Works (as applicable) shall be quoted separately (Schedule No. 4) and shall include rates or prices for all labour, Bidder's equipment, temporary works, materials, consumables and all matters and things of whatsoever nature, charges for insurance covers other than inland transit Insurance including operations and maintenance services, the provision of operations and maintenance manuals, training of employer's personnel, etc., and other supply of services, as identified in the Bidding Documents, as necessary for the proper execution/supply of the Installation Services. The prices quoted in Schedule No. 4 shall be inclusive of all Taxes, Duties, Levies & charges, except Goods and Services Tax (GST), payable in the Employer's country as of seven (7) days prior to the deadline for submission of price bids. Accordingly, all Taxes, Duties, Levies & Charges including GST on the Materials incorporated in Civil & Allied Works (as applicable) shall also be included in the prices quoted in Schedule No. 4 & no Separate</u></p>

Amendment no. 1 to for NIT No : 40086783

Sl. No.	Reference	Description as mentioned in Bidding Document	Description to be Read as
		<p><u>country as of seven (7) days prior to the deadline for submission of Price Bids. Accordingly, all Taxes, Duties, Levis & Charges including GST on the Materials incorporated in Civil & Allied Works (as applicable) shall also be included in the prices quoted in Schedule No. 4 & no Separate payment on this account, whatsoever, shall be made by Employer.</u></p> <p>Notwithstanding anything stated above, in case of services covered under Reverse Charge Mechanism, bidder shall quote only basic price for said service and for evaluation the bid of Supplier of Services shall be cost compensated as per the GST rate applicable as per GST Law.</p> <p>Due Input Tax credits under GST as per the relevant Govt. Policy, wherever applicable, shall be taken into account by the Bidder while quoting his prices.</p> <p>v. Schedule No. 5: Not Applicable</p> <p>vi. Schedule No. 6: <u>Taxes and Duties, applicable on Ex-works (India) price component (Schedule-2), not included in bid price (per Unit).</u></p> <p>vii. Schedule No. 7: <u>Break up of different taxes including</u></p>	<p><u>payment on this account, whatsoever, shall be made by Employer.</u></p> <p>Notwithstanding anything stated above, in case of services covered under Reverse Charge Mechanism, bidder shall quote only basic price for said service and for evaluation the bid of Supplier of Services shall be cost compensated as per the GST rate applicable as per GST Law.</p> <p>Due Input Tax credits under GST as per the relevant Govt. Policy, wherever applicable, shall be taken into account by the Bidder while quoting his prices.</p> <p>xi. Schedule No. 5: Not Applicable</p> <p>xii. Schedule No. 6: <u>Goods and Services Tax (GST), applicable on Schedules - 2, 3 & 4, not included in bid price (per Unit).</u></p> <p><u>Goods and Services Tax (GST) applicable on goods and services specified in Schedule Nos. 2, 3 & 4 shall not be included in respective schedules, but shall be quoted separately in Schedule No. 6. The Goods & Services Tax (GST) quoted by the bidder in Schedule No. 6 shall be as applicable in the Employer's country as on seven (7) days prior to the deadline for</u></p>

Amendment no. 1 to for NIT No : 40086783

Sl. No.	Reference	Description as mentioned in Bidding Document	Description to be Read as
		<p><u>GST included in the price quoted in schedule 3 & 4 against different items (per Unit).</u></p> <p>viii. Schedule No. 8: The details of supply of Item/Equipment and Mandatory Spares and services which are under Reverse Charge Mechanism as per GST act and included in schedule 1,2,3 &4 (per Unit).</p> <p>In case RCM is applicable on any Service and the Service with value has not been specified by the Bidder in Schedule 8, RCM paid by Employer shall be to Bidders account.</p> <p>Bidders shall note that the Items/ Hardware and software included in Schedule No.1 and 2 above shall exclude all materials used in civil, building and other construction works, if any. All such materials shall be included and priced under Schedule No.4 (Installation Services).</p> <p>The terms EXW, FOB, CIF, etc., shall be governed by the rules prescribed in the current edition of Incoterms, published by the International Chamber of Commerce, 38, Cours Albert 1er, 75008, Paris, France.</p> <p>Price Bid should not contain any matter in respect of Technical and / or Commercial aspects other than the details specifically sought in the Price Bid. If the</p>	<p><u>submission of Price Bids.</u></p> <p>xiii. Schedule No. 7: <u>NOT USED.</u></p> <p>xiv. Schedule No. 8: The details of supply of Item/Equipment and Mandatory Spares and services which are under Reverse Charge Mechanism as per GST act and included in schedule 1,2,3 &4 (per Unit).</p> <p>In case RCM is applicable on any Service and the Service with value has not been specified by the Bidder in Schedule 8, RCM paid by Employer shall be to Bidders account.</p> <p><u>For the above purpose, price components of Schedule-4, if quoted in foreign currency and so incorporated in the contract, shall be converted to Indian Rupees as per the exchange rate determined by relevant GST notifications / rules prevailing on the date and time of supply of goods and services.</u></p> <p><u>The prices quoted in Schedule Nos. 2, 3 & 4 shall be inclusive of all Taxes, Duties, Levies & charges, except Goods and Services Tax (GST), payable in the Employer's country as of seven (7) days prior to the deadline for submission of price bids.</u></p>

Amendment no. 1 to for NIT No : 40086783

Sl. No.	Reference	Description as mentioned in Bidding Document	Description to be Read as
		<p>Technical/commercial matters indicated in Price Bid are found to be in contradiction with the details furnished in Techno-Commercial Bid, the details furnished in Techno-Commercial Bid shall prevail.</p> <p>The Price Bid submitted by the Bidder shall comprise of the following:</p> <p>Bidders shall give a breakdown of the prices in the manner and detail called for in the Price Schedules.</p> <p>The Attachments (1P and 2P) and the price schedules shall be uploaded in General Data through 'Attachment' link provided in "Unpriced Bid" tab. (Bidders may note that the attachment (1P and 2P) and price schedule should not be uploaded in C Folder)</p> <p>The total amount of each of the schedule (Schedule 1 to Schedule 4 and Schedule 6) shall be filled up in Basic Price Conditions field of the items for respective item specified in Item data of Main Screen of Bid Invitation. The total bid price(s) (per Unit) (i.e, summation of Schedule 1 to Schedule 4 and Schedule 6) is automatically computed which can be viewed by the Bidder through Output Preview tab in Main Screen of Bid Invitation.</p> <p>In case of discrepancy between unit price and total price of schedules (excel files), the unit price will be considered as</p>	<p>Bidders shall note that the Items/ Hardware and software included in Schedule No.1 and 2 above shall exclude all materials used in civil, building and other construction works, if any. All such materials shall be included and priced under Schedule No.4 (Installation Services).</p> <p>The terms EXW, FOB, CIF, etc., shall be governed by the rules prescribed in the current edition of Incoterms, published by the International Chamber of Commerce, 38, Cours Albert 1er, 75008, Paris, France.</p> <p>Price Bid should not contain any matter in respect of Technical and / or Commercial aspects other than the details specifically sought in the Price Bid. If the Technical/commercial matters indicated in Price Bid are found to be in contradiction with the details furnished in Techno-Commercial Bid, the details furnished in Techno-Commercial Bid shall prevail.</p> <p>The Price Bid submitted by the Bidder shall comprise of the following:</p> <p>Bidders shall give a breakdown of the prices in the manner and detail called for in the Price Schedules.</p> <p>The Attachments (1P and 2P) and the price schedules shall be uploaded in General Data through 'Attachment' link provided in "Unpriced Bid" tab. (Bidders may note that the</p>

Amendment no. 1 to for NIT No : 40086783

Sl. No.	Reference	Description as mentioned in Bidding Document	Description to be Read as
		<p>correct.</p> <p>In case of discrepancy between unit price and total price, which is obtained by multiplying the unit price and quantity, or between sub-totals and the total price, the unit or subtotal price shall prevail, and the total price shall be corrected accordingly.</p> <p>The prices in excel file shall prevail the prices in On line BPS.</p> <p>Bidders must quote the break up of rate of taxes & duties. In case bidder has indicated (Zero/blank) taxes & duties in the online BPS and Price Schedule (excel files) same shall be treated as included in the price. In such case, Bidders must indicate the rate of tax in the proposal. In case rate of tax included in the price is not given by the bidder, no variation shall be payable.</p> <p>Bidders may note that NTPC shall not be issuing any concessional Sales tax form.</p>	<p>attachment (1P and 2P) and price schedule should not be uploaded in C Folder)</p> <p>The total amount of each of the schedule (Schedule 1 to Schedule 4 and Schedule 6) shall be filled up in Basic Price Conditions field of the items for respective item specified in Item data of Main Screen of Bid Invitation. The total bid price(s) (per Unit) (i.e, summation of Schedule 1 to Schedule 4 and Schedule 6) is automatically computed which can be viewed by the Bidder through Output Preview tab in Main Screen of Bid Invitation.</p> <p>In case of discrepancy between unit price and total price of schedules (excel files), the unit price will be considered as correct.</p> <p>In case of discrepancy between unit price and total price, which is obtained by multiplying the unit price and quantity, or between sub-totals and the total price, the unit or subtotal price shall prevail, and the total price shall be corrected accordingly.</p> <p>The prices in excel file shall prevail the prices in On line BPS.</p> <p>Bidders must quote the break up of rate of taxes & duties. In case bidder has indicated (Zero/blank) taxes & duties in the online BPS and Price Schedule (excel files) same shall be treated as included in the price. In such case, Bidders must</p>

Amendment no. 1 to for NIT No : 40086783

Sl. No.	Reference	Description as mentioned in Bidding Document	Description to be Read as
			indicate the rate of tax in the proposal. In case rate of tax included in the price is not given by the bidder, no variation shall be payable.
2.	Volume-II Section-I Special Purchase Conditions 39.0 PAYMENT TERMS {Clause 62.0 of GPC}	<p>TERMS OF PAYMENT</p> <p>A. Schedule No. 1 : Items/ Hardware and software to be supplied from abroad (Schedule No.1) shall be quoted on CIF (Indian port-of-entry) basis.</p> <p>In respect of Items/ Hardware and software supplied from abroad the following payments shall be made subject to clause no. 39.1 of SPC:</p> <p>I. Five Percent (5%) of the total CIF (Items/ Hardware and software) price component as Initial Advance Payment on :</p> <p style="padding-left: 40px;">i. Acceptance of Notification of Award and Signing of the Contract Agreement.</p> <p style="padding-left: 40px;">ii. Submission of an unconditional Bank Guarantee covering the advance amount which shall be initially kept valid upto (ninety) 90 days beyond the schedule date for successful Completion of the last facility under the Package. However, in case of delay in completion of facilities, the validity of this Bank Guarantee shall be extended by the period of such delay. Proforma of Bank Guarantee is enclosed in Volume-I SECTION – IV (Forms /Bid Data Sheet) Form</p>	<p>TERMS OF PAYMENT</p> <p>F. Schedule No. 1 : Items/ Hardware and software to be supplied from abroad (Schedule No.1) shall be quoted on CIF (Indian port-of-entry) basis.</p> <p>In respect of Items/ Hardware and software supplied from abroad the following payments shall be made subject to clause no. 39.1 of SPC:</p> <p>IX. Five Percent (5%) of the total CIF (Items/ Hardware and software) price component as Initial Advance Payment on :</p> <p style="padding-left: 40px;">v. Acceptance of Notification of Award and Signing of the Contract Agreement.</p> <p style="padding-left: 40px;">vi. Submission of an unconditional Bank Guarantee covering the advance amount which shall be initially kept valid upto (ninety) 90 days beyond the schedule date for successful Completion of the last facility under the Package. However, in case of delay in completion of facilities, the validity of this Bank Guarantee shall be extended by the period of such delay. Proforma of Bank Guarantee is enclosed in Volume-I SECTION – IV (Forms /Bid Data Sheet) Form</p>

Amendment no. 1 to for NIT No : 40086783

Sl. No.	Reference	Description as mentioned in Bidding Document	Description to be Read as
		<p>of Advance Payment Security.</p> <p>iii. Submission by the Main Contractor of an unconditional Bank Guarantee(s) towards Performance Security(s) in respect of all Contracts (including the Contracts entered into with the Contractor's Assignee, if applicable in case of Foreign Contractor), and submission by the Assignee (if applicable in case of Foreign Contractor) of an unconditional Bank Guarantee(s) towards Performance Security(s) in respect of all Contracts entered into with the Assignee, initially valid upto ninety (90) days after the end of Defects Liability Period of all equipment covered under Contract. The proforma of Bank Guarantee is enclosed in Volume-I SECTION – IV (Forms /Bid Data Sheet) Form of Performance Security.</p> <p>iv. In case Deed of Joint Undertaking by the Contractor alongwith his Associate/Collaborator forms part of the Contract then submission of an unconditional Bank guarantee from such Associate/Collaborator towards faithful performance of the Deed of Joint Undertaking for an amount specified in the deed and initially valid upto ninety (90) days after the end of Defect Liability Period of all equipment covered under the Contract. However, in case of delay in Defect Liability Period, the validity of this Bank Guarantee</p>	<p>of Advance Payment Security.</p> <p>vii. Submission by the Main Contractor of an unconditional Bank Guarantee(s) towards Performance Security(s) in respect of all Contracts (including the Contracts entered into with the Contractor's Assignee, if applicable in case of Foreign Contractor), and submission by the Assignee (if applicable in case of Foreign Contractor) of an unconditional Bank Guarantee(s) towards Performance Security(s) in respect of all Contracts entered into with the Assignee, initially valid upto ninety (90) days after the end of Defects Liability Period of all equipment covered under Contract. The proforma of Bank Guarantee is enclosed in Volume-I SECTION – IV (Forms /Bid Data Sheet) Form of Performance Security.</p> <p>viii. In case Deed of Joint Undertaking by the Contractor alongwith his Associate/Collaborator forms part of the Contract then submission of an unconditional Bank guarantee from such Associate/Collaborator towards faithful performance of the Deed of Joint Undertaking for an amount specified in the deed and initially valid upto ninety (90) days after the end of Defect Liability Period of all equipment covered under the Contract. However, in case of delay in Defect Liability Period, the validity of this Bank Guarantee</p>

Amendment no. 1 to for NIT No : 40086783

Sl. No.	Reference	Description as mentioned in Bidding Document	Description to be Read as
		<p>shall be extended by the period of such delay. The proforma of Bank Guarantee(s) shall be as enclosed in Volume-I SECTION – IV (Forms /Bid Data Sheet).</p> <p>II. Five Percent (5%) of the total Ex-works (Items/ Hardware and software) price component as Interim Advance Payment on</p> <p>i. Successful completion of Kick off Meeting at Site</p> <p>ii. Submission and approval (Approval of Employer) of all required documents and procedures as advised by EIC</p> <p>iii. Submission of an unconditional Bank Guarantee covering the Interim Advance amount which shall be initially kept valid upto (ninety) 90 days beyond the schedule date of successful Completion of the last facility under the Package. However, in case of delay in completion of facilities, the validity of this Bank Guarantee shall be extended by the period of such delay. Proforma of Bank Guarantee is enclosed in Volume-I SECTION – IV (Forms /Bid Data Sheet) Form of Advance Payment Security.</p> <p>III. Five Percent (5%) of Ex-Works price (Items/ Hardware and software) on receipt of equipment at site on unit wise prorata basis and physical verification and certification by the EIC for</p>	<p>shall be extended by the period of such delay. The proforma of Bank Guarantee(s) shall be as enclosed in Volume-I SECTION – IV (Forms /Bid Data Sheet).</p> <p>X. Five Percent (5%) of the total Ex-works (Items/ Hardware and software) price component as Interim Advance Payment on</p> <p>iv. Successful completion of Kick off Meeting at Site</p> <p>v. Submission and approval (Approval of Employer) of all required documents and procedures as advised by EIC</p> <p>vi. Submission of an unconditional Bank Guarantee covering the Interim Advance amount which shall be initially kept valid upto (ninety) 90 days beyond the schedule date of successful Completion of the last facility under the Package. However, in case of delay in completion of facilities, the validity of this Bank Guarantee shall be extended by the period of such delay. Proforma of Bank Guarantee is enclosed in Volume-I SECTION – IV (Forms /Bid Data Sheet) Form of Advance Payment Security.</p> <p>XI. Five Percent (5%) of Ex-Works price (Items/ Hardware and software) on receipt of equipment at site on unit wise prorata basis and physical verification and certification by the EIC for</p>

Amendment no. 1 to for NIT No : 40086783

Sl. No.	Reference	Description as mentioned in Bidding Document	Description to be Read as
		<p>the equipment received and stored at site.</p> <p>IV. Twenty five Percent (25%) of Ex-Works price (Items/ Hardware and software) on successful completion of SAT for "SH/RH Temperature Excursion Reduction" on unit wise prorata basis subject to Performance Milestone achieved and corresponding formula for payment as under.</p> <p>V. Ten Percent (10%) of Ex-Works price (Items/ Hardware and software) on successful completion of SAT for "Faster load Ramp up/Ramp Down" on unit wise prorata basis subject to Performance Milestone achieved and corresponding formula for payment as under.</p> <p>VI. Forty Percent (40%) of Ex-Works price (Items/ Hardware and software) on successful completion of SAT for "Combustion Optimization & Soot Blowing Optimization" on unit wise prorata basis subject to Performance Milestone achieved and corresponding formula for payment as under.</p> <p>VII. Five (5%) of Ex-Works price (Items/ Hardware and software) on successful completion of SAT for "Reduce Min. stable load" on unit wise prorata basis subject to Performance Milestone achieved and corresponding formula for payment as under.</p> <p>Milestone achieved linked payment formula</p>	<p>the equipment received and stored at site.</p> <p>XII. Twenty five Percent (25%) of Ex-Works price (Items/ Hardware and software) on successful completion of SAT for "SH/RH Temperature Excursion Reduction" on unit wise prorata basis subject to Performance Milestone achieved and corresponding formula for payment as under.</p> <p>XIII. Ten Percent (10%) of Ex-Works price (Items/ Hardware and software) on successful completion of SAT for "Faster load Ramp up/Ramp Down" on unit wise prorata basis subject to Performance Milestone achieved and corresponding formula for payment as under.</p> <p>XIV. Forty Percent (40%) of Ex-Works price (Items/ Hardware and software) on successful completion of SAT for "Combustion Optimization & Soot Blowing Optimization" on unit wise prorata basis subject to Performance Milestone achieved and corresponding formula for payment as under.</p> <p>XV. Five (5%) of Ex-Works price (Items/ Hardware and software) on successful completion of SAT for "Reduce Min. stable load" on unit wise prorata basis subject to Performance Milestone achieved and corresponding formula for payment as under.</p> <p>Milestone achieved linked payment formula</p>

Amendment no. 1 to for NIT No : 40086783

Sl. No.	Reference	Description as mentioned in Bidding Document			Description to be Read as		
		Sl. No	Performance Milestone	Milestone	Sl. No	Performance Milestone	Milestone
		A	Net Improvement in Standard Deviation of SH & RH steam temperature excursion (as per clause 8.16 of Volume III - Technical specifications and scope of work)	<p>1. For, Net Improvement in Standard Deviation of SH & RH steam temperature excursion between 10% to 50%, payment shall be in the range of 5% to 25% of PO price.</p> <p>Example: Net Improvement = 30%, payment (incl. Tax) is calculated as follows: $5\% + [\{ (25\%-5\%) / (50\%-10\%) \} * (30\% - 10\%)]$</p> <p>2. For Net Improvement in Standard Deviation of SH & RH steam temperature excursion of 10% ; Payment of 5% of PO price (incl. Tax).</p> <p>3. For Net Improvement in Standard Deviation of</p>	A	Net Improvement in Standard Deviation of SH & RH steam temperature excursion (as per clause 8.16 of Volume III - Technical specifications and scope of work)	<p>1. For, Net Improvement in Standard Deviation of SH & RH steam temperature excursion between 10% to 50%, payment shall be in the range of 5% to 25% of PO price.</p> <p>Example: Net Improvement = 30%, payment (incl. Tax) is calculated as follows: $5\% + [\{ (25\%-5\%) / (50\%-10\%) \} * (30\% - 10\%)]$</p> <p>2. For Net Improvement in Standard Deviation of SH & RH steam temperature excursion of 10% ; Payment of 5% of PO price (incl. Tax).</p> <p>3. For Net Improvement in Standard Deviation of</p>

Amendment no. 1 to for NIT No : 40086783

Sl. No.	Reference	Description as mentioned in Bidding Document			Description to be Read as		
				<p>SH & RH steam temperature excursion of <10%; no payment.</p>			<p>SH & RH steam temperature excursion of <10%; no payment.</p>
		B	<p>Net Improvement in Standard Deviation of Throttle Pressure, SH and RH steam temperature excursion (as per clause 8.16 of Volume III - Technical specifications and scope of work)</p>	<p>1. For, Net Improvement in Standard Deviation of Throttle Pressure, SH and RH steam temperature excursion between 10% to 50%, payment shall be in the range of 2% to 10% of PO price.</p> <p>Example: Net Improvement = 30%, payment (incl. Tax) is calculated as follow: $2\% + [\{ (10\%-2\%) / (50\%-10\%) \} * (30\% - 10\%)]$</p> <p>2. For Net Improvement in Standard Deviation of Throttle Pressure, SH and RH steam temperature excursion of 10% ; Payment of 2% of PO price (incl. Tax).</p> <p>3. For Net Improvement in</p>	B	<p>Net Improvement in Standard Deviation of Throttle Pressure, SH and RH steam temperature excursion (as per clause 8.16 of Volume III - Technical specifications and scope of work)</p>	<p>1. For, Net Improvement in Standard Deviation of Throttle Pressure, SH and RH steam temperature excursion between 10% to 50%, payment shall be in the range of 2% to 10% of PO price.</p> <p>Example: Net Improvement = 30%, payment (incl. Tax) is calculated as follow: $2\% + [\{ (10\%-2\%) / (50\%-10\%) \} * (30\% - 10\%)]$</p> <p>2. For Net Improvement in Standard Deviation of Throttle Pressure, SH and RH steam temperature excursion of 10% ; Payment of 2% of PO price (incl. Tax).</p> <p>3. For Net Improvement in</p>

Amendment no. 1 to for NIT No : 40086783

Sl. No.	Reference	Description as mentioned in Bidding Document			Description to be Read as		
				<p>Standard Deviation of Throttle Pressure, SH and RH steam temperature excursion of <10%; no payment.</p>			<p>Standard Deviation of Throttle Pressure, SH and RH steam temperature excursion of <10%; no payment.</p>
		C	<p>Net Improvement in Unit Heat Rate by Combustion optimization and Soot blowing optimization (Summation of results of SAT of each of this APC solution) (as per clause 8.16 of Volume III - Technical specifications and scope of work)</p>	<p>1. For Net improvement in Unit Heat rate between 0.1% to 0.5%, payment shall be in the range of 8% to 40% of PO price.</p> <p>Example: Heat rate improvement = 0.15%, payment (incl. Tax) is calculated as follow: $8\% + [\{ (40\%-8\%) / (0.5\% - 0.1\%) \} * (0.15\% - 0.1\%)]$</p> <p>2. For Net improvement in Unit Heat rate of 0.1% ; Payment of 8% of PO price (incl. Tax).</p> <p>3. For Net improvement in Unit Heat rate of <0.1% ; no payment.</p>	C	<p>Net Improvement in Unit Heat Rate by Combustion optimization and Soot blowing optimization (Summation of results of SAT of each of this APC solution) (as per clause 8.16 of Volume III - Technical specifications and scope of work)</p>	<p>1. For Net improvement in Unit Heat rate between 0.1% to 0.5%, payment shall be in the range of 8% to 40% of PO price.</p> <p>Example: Heat rate improvement = 0.15%, payment (incl. Tax) is calculated as follow: $8\% + [\{ (40\%-8\%) / (0.5\% - 0.1\%) \} * (0.15\% - 0.1\%)]$</p> <p>2. For Net improvement in Unit Heat rate of 0.1% ; Payment of 8% of PO price (incl. Tax).</p> <p>3. For Net improvement in Unit Heat rate of <0.1% ; no payment.</p>

Amendment no. 1 to for NIT No : 40086783

Sl. No.	Reference	Description as mentioned in Bidding Document			Description to be Read as								
			<table border="1"> <tr> <td data-bbox="667 367 724 560">D</td> <td data-bbox="724 367 972 560">Improvement in Stable Min. Load (as per clause 8.16 of Volume III - Technical specifications and scope of work)</td> </tr> </table>	D	Improvement in Stable Min. Load (as per clause 8.16 of Volume III - Technical specifications and scope of work)	<table border="1"> <tr> <td data-bbox="972 367 1268 560">1. For Achieving Stable Min load of 50% loading factor, payment of 5% of PO price</td> </tr> </table>	1. For Achieving Stable Min load of 50% loading factor, payment of 5% of PO price		<table border="1"> <tr> <td data-bbox="1367 367 1423 560">D</td> <td data-bbox="1423 367 1671 560">Improvement in Stable Min. Load (as per clause 8.16 of Volume III - Technical specifications and scope of work)</td> </tr> </table>	D	Improvement in Stable Min. Load (as per clause 8.16 of Volume III - Technical specifications and scope of work)	<table border="1"> <tr> <td data-bbox="1671 367 1967 560">1. For Achieving Stable Min load of 50% loading factor, payment of 5% of PO price</td> </tr> </table>	1. For Achieving Stable Min load of 50% loading factor, payment of 5% of PO price
D	Improvement in Stable Min. Load (as per clause 8.16 of Volume III - Technical specifications and scope of work)												
1. For Achieving Stable Min load of 50% loading factor, payment of 5% of PO price													
D	Improvement in Stable Min. Load (as per clause 8.16 of Volume III - Technical specifications and scope of work)												
1. For Achieving Stable Min load of 50% loading factor, payment of 5% of PO price													
		<p>VIII. Ten percent (10%) of Ex-Works price (Items/ Hardware and software) on Completion of Facilities unitwise and its Certification by the Project Manager/EIC.</p> <p>B. Schedule No. 2 : Items/ Hardware and software to be supplied from within the Employer's Country (Schedule No. 2) quoted on Ex-works (India) basis:</p> <p>In respect of Items/ Hardware and software supplied from within the Employer's country the following payment shall be made subject to clause no. 39.1 of SPC:</p> <p>I. Five Percent (5%) of the total Ex-works (Items/ Hardware and software) price component as Initial Advance Payment on :</p> <p style="margin-left: 40px;">i. Acceptance of Notification of Award and Signing of the Contract Agreement.</p> <p style="margin-left: 40px;">ii. Submission of an unconditional Bank Guarantee</p>	<p>XVI. Five percent (5%) of Ex-Works price (Items/ Hardware and software) on Completion of Facilities unitwise and its Certification by the Project Manager/EIC.</p> <p>G. Schedule No. 2 : Items/ Hardware and software to be supplied from within the Employer's Country (Schedule No. 2) quoted on Ex-works (India) basis:</p> <p>In respect of Items/ Hardware and software supplied from within the Employer's country the following payment shall be made subject to clause no. 39.1 of SPC:</p> <p>IX. Five Percent (5%) of the total Ex-works (Items/ Hardware and software) price component as Initial Advance Payment on :</p> <p style="margin-left: 40px;">v. Acceptance of Notification of Award and Signing of the Contract Agreement.</p> <p style="margin-left: 40px;">vi. Submission of an unconditional Bank Guarantee</p>										

Amendment no. 1 to for NIT No : 40086783

Sl. No.	Reference	Description as mentioned in Bidding Document	Description to be Read as
		<p>covering the advance amount which shall be initially kept valid upto (ninety) 90 days beyond the schedule date for successful Completion of the last facility under the Package. However, in case of delay in completion of facilities, the validity of this Bank Guarantee shall be extended by the period of such delay. Proforma of Bank Guarantee is enclosed in Volume-I SECTION – IV (Forms /Bid Data Sheet) Form of Advance Payment Security.</p> <p>iii. Submission by the Main Contractor of an unconditional Bank Guarantee(s) towards Performance Security(s) in respect of all Contracts (including the Contracts entered into with the Contractor's Assignee, if applicable in case of Foreign Contractor), and submission by the Assignee (if applicable in case of Foreign Contractor) of an unconditional Bank Guarantee(s) towards Performance Security(s) in respect of all Contracts entered into with the Assignee, initially valid upto ninety (90) days after the end of Defects Liability Period of all equipment covered under Contract. The proforma of Bank Guarantee is enclosed in Volume-I SECTION – IV (Forms /Bid Data Sheet) Form of Performance Security.</p> <p>iv. In case Deed of Joint Undertaking by the Contractor alongwith his Associate/Collaborator forms part of</p>	<p>covering the advance amount which shall be initially kept valid upto (ninety) 90 days beyond the schedule date for successful Completion of the last facility under the Package. However, in case of delay in completion of facilities, the validity of this Bank Guarantee shall be extended by the period of such delay. Proforma of Bank Guarantee is enclosed in Volume-I SECTION – IV (Forms /Bid Data Sheet) Form of Advance Payment Security.</p> <p>vii. Submission by the Main Contractor of an unconditional Bank Guarantee(s) towards Performance Security(s) in respect of all Contracts (including the Contracts entered into with the Contractor's Assignee, if applicable in case of Foreign Contractor), and submission by the Assignee (if applicable in case of Foreign Contractor) of an unconditional Bank Guarantee(s) towards Performance Security(s) in respect of all Contracts entered into with the Assignee, initially valid upto ninety (90) days after the end of Defects Liability Period of all equipment covered under Contract. The proforma of Bank Guarantee is enclosed in Volume-I SECTION – IV (Forms /Bid Data Sheet) Form of Performance Security.</p> <p>viii. In case Deed of Joint Undertaking by the Contractor alongwith his Associate/Collaborator forms part of</p>

Amendment no. 1 to for NIT No : 40086783

Sl. No.	Reference	Description as mentioned in Bidding Document	Description to be Read as
		<p>the Contract then submission of an unconditional Bank guarantee from such Associate/Collaborator towards faithful performance of the Deed of Joint Undertaking for an amount specified in the deed and initially valid upto ninety (90) days after the end of Defect Liability Period of all equipment covered under the Contract. However, in case of delay in Defect Liability Period, the validity of this Bank Guarantee shall be extended by the period of such delay. The proforma of Bank Guarantee(s) shall be as enclosed in Volume-I SECTION – IV (Forms /Bid Data Sheet).</p> <p>II. Five Percent (5%) of the total Ex-works (Items/ Hardware and software) price component as Interim Advance Payment on</p> <ul style="list-style-type: none"> i. Successful completion of Kick off Meeting at Site ii. Finalization, submission and approval (Approval of Employer) of all required documents and procedures as advised by EIC iii. Submission of an unconditional Bank Guarantee covering the Interim Advance amount which shall be initially kept valid upto (ninety) 90 days beyond the schedule date of successful Completion of the last facility under the Package. However, in case of delay in completion of facilities, the validity of this 	<p>the Contract then submission of an unconditional Bank guarantee from such Associate/Collaborator towards faithful performance of the Deed of Joint Undertaking for an amount specified in the deed and initially valid upto ninety (90) days after the end of Defect Liability Period of all equipment covered under the Contract. However, in case of delay in Defect Liability Period, the validity of this Bank Guarantee shall be extended by the period of such delay. The proforma of Bank Guarantee(s) shall be as enclosed in Volume-I SECTION – IV (Forms /Bid Data Sheet).</p> <p>X. Five Percent (5%) of the total Ex-works (Items/ Hardware and software) price component as Interim Advance Payment on</p> <ul style="list-style-type: none"> iv. Successful completion of Kick off Meeting at Site v. Finalization, submission and approval (Approval of Employer) of all required documents and procedures as advised by EIC vi. Submission of an unconditional Bank Guarantee covering the Interim Advance amount which shall be initially kept valid upto (ninety) 90 days beyond the schedule date of successful Completion of the last facility under the Package. However, in case of delay in completion of facilities, the validity of this

Amendment no. 1 to for NIT No : 40086783

Sl. No.	Reference	Description as mentioned in Bidding Document	Description to be Read as
		<p>Bank Guarantee shall be extended by the period of such delay. Proforma of Bank Guarantee is enclosed in Volume-I SECTION – IV (Forms /Bid Data Sheet) Form of Advance Payment Security.</p> <p>III. Five Percent (5%) of Ex-Works price (Items/ Hardware and software) on receipt of equipment at site on unit wise prorata basis and physical verification and certification by the EIC for the equipment received and stored at site.</p> <p>IV. Twenty five Percent (25%) of Ex-Works price (Items/ Hardware and software) on successful completion of SAT for “SH/RH Temperature Excursion Reduction” on unit wise prorata basis subject to Performance Milestone achieved and corresponding formula for payment as under.</p> <p>V. Ten Percent (10%) of Ex-Works price (Items/ Hardware and software) on successful completion of SAT for “Faster load Ramp up/Ramp Down” on unit wise prorata basis subject to Performance Milestone achieved and corresponding formula for payment as under.</p> <p>VI. Forty Percent (40%) of Ex-Works price (Items/ Hardware and software) on successful completion of SAT for “Combustion Optimization & Soot Blowing Optimization” on unit wise prorata basis subject to Performance Milestone achieved and corresponding formula for payment as under.</p> <p>VII. Five (5%) of Ex-Works price (Items/ Hardware and software) on successful completion of SAT for “Reduce Min. stable load” on</p>	<p>Bank Guarantee shall be extended by the period of such delay. Proforma of Bank Guarantee is enclosed in Volume-I SECTION – IV (Forms /Bid Data Sheet) Form of Advance Payment Security.</p> <p>XI. Five Percent (5%) of Ex-Works price (Items/ Hardware and software) on receipt of equipment at site on unit wise prorata basis and physical verification and certification by the EIC for the equipment received and stored at site.</p> <p>XII. Twenty five Percent (25%) of Ex-Works price (Items/ Hardware and software) on successful completion of SAT for “SH/RH Temperature Excursion Reduction” on unit wise prorata basis subject to Performance Milestone achieved and corresponding formula for payment as under.</p> <p>XIII. Ten Percent (10%) of Ex-Works price (Items/ Hardware and software) on successful completion of SAT for “Faster load Ramp up/Ramp Down” on unit wise prorata basis subject to Performance Milestone achieved and corresponding formula for payment as under.</p> <p>XIV. Forty Percent (40%) of Ex-Works price (Items/ Hardware and software) on successful completion of SAT for “Combustion Optimization & Soot Blowing Optimization” on unit wise prorata basis subject to Performance Milestone achieved and corresponding formula for payment as under.</p> <p>XV. Five (5%) of Ex-Works price (Items/ Hardware and software) on successful completion of SAT for “Reduce Min. stable load” on</p>

Amendment no. 1 to for NIT No : 40086783

SI. No.	Reference	Description as mentioned in Bidding Document	Description to be Read as												
		<p>unit wise prorata basis subject to Performance Milestone achieved and corresponding formula for payment as under.</p> <p>Milestone achieved linked payment formula</p> <table border="1" data-bbox="667 529 1257 1205"> <thead> <tr> <th data-bbox="667 529 724 667">SI. No</th> <th data-bbox="724 529 972 667">Performance Milestone</th> <th data-bbox="972 529 1257 667">Milestone</th> </tr> </thead> <tbody> <tr> <td data-bbox="667 667 724 1205">A</td> <td data-bbox="724 667 972 1205">Net Improvement in Standard Deviation of SH & RH steam temperature excursion (as per clause 8.16 of Volume III - Technical specifications and scope of work)</td> <td data-bbox="972 667 1257 1205"> 1. For, Net Improvement in Standard Deviation of SH & RH steam temperature excursion between 10% to 50%, payment shall be in the range of 5% to 25% of PO price. Example: Net Improvement = 30%, payment (incl. Tax) is calculated as follows: $5\% + [\{ (25\%-5\%) / (50\%-10\%) \} * (30\% - 10\%)]$ 2. For Net Improvement in Standard Deviation of SH & RH steam temperature excursion of </td> </tr> </tbody> </table>	SI. No	Performance Milestone	Milestone	A	Net Improvement in Standard Deviation of SH & RH steam temperature excursion (as per clause 8.16 of Volume III - Technical specifications and scope of work)	1. For, Net Improvement in Standard Deviation of SH & RH steam temperature excursion between 10% to 50%, payment shall be in the range of 5% to 25% of PO price. Example: Net Improvement = 30%, payment (incl. Tax) is calculated as follows: $5\% + [\{ (25\%-5\%) / (50\%-10\%) \} * (30\% - 10\%)]$ 2. For Net Improvement in Standard Deviation of SH & RH steam temperature excursion of	<p>unit wise prorata basis subject to Performance Milestone achieved and corresponding formula for payment as under.</p> <p>Milestone achieved linked payment formula</p> <table border="1" data-bbox="1367 529 1957 1205"> <thead> <tr> <th data-bbox="1367 529 1423 667">SI. No</th> <th data-bbox="1423 529 1671 667">Performance Milestone</th> <th data-bbox="1671 529 1957 667">Milestone</th> </tr> </thead> <tbody> <tr> <td data-bbox="1367 667 1423 1205">A</td> <td data-bbox="1423 667 1671 1205">Net Improvement in Standard Deviation of SH & RH steam temperature excursion (as per clause 8.16 of Volume III - Technical specifications and scope of work)</td> <td data-bbox="1671 667 1957 1205"> 1. For, Net Improvement in Standard Deviation of SH & RH steam temperature excursion between 10% to 50%, payment shall be in the range of 5% to 25% of PO price. Example: Net Improvement = 30%, payment (incl. Tax) is calculated as follows: $5\% + [\{ (25\%-5\%) / (50\%-10\%) \} * (30\% - 10\%)]$ 2. For Net Improvement in Standard Deviation of SH & RH steam temperature excursion of </td> </tr> </tbody> </table>	SI. No	Performance Milestone	Milestone	A	Net Improvement in Standard Deviation of SH & RH steam temperature excursion (as per clause 8.16 of Volume III - Technical specifications and scope of work)	1. For, Net Improvement in Standard Deviation of SH & RH steam temperature excursion between 10% to 50%, payment shall be in the range of 5% to 25% of PO price. Example: Net Improvement = 30%, payment (incl. Tax) is calculated as follows: $5\% + [\{ (25\%-5\%) / (50\%-10\%) \} * (30\% - 10\%)]$ 2. For Net Improvement in Standard Deviation of SH & RH steam temperature excursion of
SI. No	Performance Milestone	Milestone													
A	Net Improvement in Standard Deviation of SH & RH steam temperature excursion (as per clause 8.16 of Volume III - Technical specifications and scope of work)	1. For, Net Improvement in Standard Deviation of SH & RH steam temperature excursion between 10% to 50%, payment shall be in the range of 5% to 25% of PO price. Example: Net Improvement = 30%, payment (incl. Tax) is calculated as follows: $5\% + [\{ (25\%-5\%) / (50\%-10\%) \} * (30\% - 10\%)]$ 2. For Net Improvement in Standard Deviation of SH & RH steam temperature excursion of													
SI. No	Performance Milestone	Milestone													
A	Net Improvement in Standard Deviation of SH & RH steam temperature excursion (as per clause 8.16 of Volume III - Technical specifications and scope of work)	1. For, Net Improvement in Standard Deviation of SH & RH steam temperature excursion between 10% to 50%, payment shall be in the range of 5% to 25% of PO price. Example: Net Improvement = 30%, payment (incl. Tax) is calculated as follows: $5\% + [\{ (25\%-5\%) / (50\%-10\%) \} * (30\% - 10\%)]$ 2. For Net Improvement in Standard Deviation of SH & RH steam temperature excursion of													

Amendment no. 1 to for NIT No : 40086783

Sl. No.	Reference	Description as mentioned in Bidding Document			Description to be Read as		
				10% ; Payment of 5% of PO price (incl. Tax). 3. For Net Improvement in Standard Deviation of SH & RH steam temperature excursion of <10%; no payment.			10% ; Payment of 5% of PO price (incl. Tax). 3. For Net Improvement in Standard Deviation of SH & RH steam temperature excursion of <10%; no payment.
		B	Net Improvement in Standard Deviation of Throttle Pressure, SH and RH steam temperature excursion (as per clause 8.16 of Volume III - Technical specifications and scope of work)	1. For, Net Improvement in Standard Deviation of Throttle Pressure, SH and RH steam temperature excursion between 10% to 50%, payment shall be in the range of 2% to 10% of PO price. Example: Net Improvement = 30%, payment (incl. Tax) is calculated as follow: $2\% + [\{ (10\%-2\%) / (50\%-10\%) \} * (30\% - 10\%)]$ 2. For Net Improvement in Standard Deviation of Throttle Pressure, SH and RH steam temperature excursion of 10% ; Payment of 2% of	B	Net Improvement in Standard Deviation of Throttle Pressure, SH and RH steam temperature excursion (as per clause 8.16 of Volume III - Technical specifications and scope of work)	1. For, Net Improvement in Standard Deviation of Throttle Pressure, SH and RH steam temperature excursion between 10% to 50%, payment shall be in the range of 2% to 10% of PO price. Example: Net Improvement = 30%, payment (incl. Tax) is calculated as follow: $2\% + [\{ (10\%-2\%) / (50\%-10\%) \} * (30\% - 10\%)]$ 2. For Net Improvement in Standard Deviation of Throttle Pressure, SH and RH steam temperature excursion of 10% ; Payment of 2% of

Amendment no. 1 to for NIT No : 40086783

Sl. No.	Reference	Description as mentioned in Bidding Document			Description to be Read as		
				PO price (incl. Tax). 3. For Net Improvement in Standard Deviation of Throttle Pressure, SH and RH steam temperature excursion of <10%; no payment.			PO price (incl. Tax). 3. For Net Improvement in Standard Deviation of Throttle Pressure, SH and RH steam temperature excursion of <10%; no payment.
		C	Net Improvement in Unit Heat Rate by Combustion optimization and Soot blowing optimization (Summation of results of SAT of each of this APC solution) (as per clause 8.16 of Volume III - Technical specifications and scope of work)	1. For Net improvement in Unit Heat rate between 0.1% to 0.5%, payment shall be in the range of 8% to 40% of PO price. Example: Heat rate improvement = 0.15%, payment (incl. Tax) is calculated as follow: $8\% + [\{ (40\%-8\%) / (0.5\% - 0.1\%) \} * (0.15\% - 0.1\%)]$ 2. For Net improvement in Unit Heat rate of 0.1% ; Payment of 8% of PO price (incl. Tax). 3. For Net improvement in Unit Heat rate of <0.1% ; no payment.	C	Net Improvement in Unit Heat Rate by Combustion optimization and Soot blowing optimization (Summation of results of SAT of each of this APC solution) (as per clause 8.16 of Volume III - Technical specifications and scope of work)	1. For Net improvement in Unit Heat rate between 0.1% to 0.5%, payment shall be in the range of 8% to 40% of PO price. Example: Heat rate improvement = 0.15%, payment (incl. Tax) is calculated as follow: $8\% + [\{ (40\%-8\%) / (0.5\% - 0.1\%) \} * (0.15\% - 0.1\%)]$ 2. For Net improvement in Unit Heat rate of 0.1% ; Payment of 8% of PO price (incl. Tax). 3. For Net improvement in Unit Heat rate of <0.1% ; no payment.

Amendment no. 1 to for NIT No : 40086783

Sl. No.	Reference	Description as mentioned in Bidding Document		Description to be Read as			
			<p>D Improvement in Stable Min. Load (as per clause 8.16 of Volume III - Technical specifications and scope of work)</p>	<p>1. For Achieving Stable Min load of 50% loading factor, payment of 5% of PO price.</p>		<p>D Improvement in Stable Min. Load (as per clause 8.16 of Volume III - Technical specifications and scope of work)</p>	<p>1. For Achieving Stable Min load of 50% loading factor, payment of 5% of PO price.</p>
		VIII.	<p>Ten percent (10%) of Ex-Works price (Items/ Hardware and software) on Completion of Facilities unitwise and its Certification by the Project Manager/EIC.</p>		XVI.	<p>Five percent (5%) of Ex-Works price (Items/ Hardware and software) on Completion of Facilities unitwise and its Certification by the Project Manager/EIC.</p>	
		C.	<p>Schedule No. 3 : Local Transportation Hundred Percent (100%) Local Transportation (including inland insurance charges) for the Items/ Hardware and software covered in Schedule-2 shall be paid to the Contractor on receipt of equipment at site on unit wise Prorata basis and on production of invoices by the Contractor.</p>		C.	<p>Schedule No. 3 : Local Transportation <u>inclusive of all Taxes, Duties, Levies & charges, except Goods and Services Tax (GST), payable in the Employer's country as of seven (7) days prior to the deadline for submission of price bids</u> Hundred Percent (100%) Local Transportation (including inland insurance charges) for the Items/ Hardware and software covered in Schedule-2 shall be paid to the Contractor on receipt of equipment at site on unit wise Prorata basis and on production of invoices by the Contractor.</p>	
		D.	<p>Schedule No. 4 : Installation Services (including AMC)</p>		D.	<p>Schedule No. 4 : Installation Services (including AMC) <u>(inclusive of all Taxes, Duties, Levies & charges, except Goods and Services Tax (GST), payable in the Employer's country as of seven (7) days prior to the deadline for submission of price bids)</u></p>	
		I.	<p>Installation Services (excluding AMC)</p> <p>Installation Services component shall be paid as under: Hundred percent (100%) of Installation Services component of each unit will be paid on successful completion of SAT and certification by the EIC.</p>				
		II.	<p>Annual Maintenance Contract(AMC)</p>				

Amendment no. 1 to for NIT No : 40086783

Sl. No.	Reference	Description as mentioned in Bidding Document	Description to be Read as
		<p>The Contractor shall be eligible for payment under the Annual Maintenance Contract (AMC) on quarterly pro-rata basis on certification by EIC regarding successful maintenance of the system by the Contractor subject to clause no. 39.1 of SPC.</p> <p>E. Schedule - 6 : Payment Terms for Taxes & Duties</p> <p>I. Indian Custom Duties or levies including Stamp Duty and Import Licence Fee if imposed in future and IGST on Imports by the Government of India or any State Government in India on the Items/ Hardware and software covered in Schedule -1 supplied from abroad to be imported into India and which will become the property of the Employer shall be paid directly by the Employer to the Government of India or the concerned authorities. However, if the local laws require such payment of the Custom duty, IGST and any other levies on imports to be made by the Contractor, the same shall be reimbursed to the Contractor on production of satisfactory evidence of having paid the custom duty amount to the concerned authorities.</p> <p>II. Notwithstanding the above, if the Contractor chooses to ship the equipment in Shipper's Containers, then the Custom duty, IGST and any other levies on imports levied on such Containers shall not be borne by the Employer and shall be payable by the Contractor himself.</p> <p>III. 100% of applicable Taxes and Duties [other than the Custom</p>	<p>I. Installation Services (excluding AMC)</p> <p>Installation Services component shall be paid as under: Hundred percent (100%) of Installation Services component of each unit will be paid on successful completion of SAT and certification by the EIC.</p> <p>II. Annual Maintenance Contract(AMC)</p> <p>The Contractor shall be eligible for payment under the Annual Maintenance Contract (AMC) on quarterly pro-rata basis on certification by EIC regarding successful maintenance of the system by the Contractor subject to clause no. 39.1 of SPC.</p> <p>E. <u>Schedule - 6</u> : Payment Terms for Taxes & <u>Duties and Custom Duties or levies including Stamp Duty and Import Licence Fee if imposed in future and IGST on Imports</u></p> <p>I. Indian Custom Duties or levies including Stamp Duty and Import Licence Fee if imposed in future and IGST on Imports by the Government of India or any State Government in India on the Items/ Hardware and software covered in Schedule -1 supplied from abroad to be imported into India and which will become the property of the Employer shall be paid directly by the Employer to the Government of India or the concerned authorities. However, if the local laws require such payment of the Custom duty, IGST and any other levies on imports to be made by the Contractor, the same shall be reimbursed to the Contractor on production of satisfactory evidence of having paid</p>

Amendment no. 1 to for NIT No : 40086783

Sl. No.	Reference	Description as mentioned in Bidding Document	Description to be Read as
		<p>duty, IGST and any other levies on imports payable as in para (i) above] which are payable by the Employer under the Contract shall be reimbursed by the Employer to the Contractor/Assignee upon receipt of equipment at site on production of satisfactory documentary evidence by the Contractor/Assignee, as applicable as per relevant GST Laws</p>	<p>the custom duty amount to the concerned authorities.</p> <p>II. Notwithstanding the above, if the Contractor chooses to ship the equipment in Shipper's Containers, then the Custom duty, IGST and any other levies on imports levied on such Containers shall not be borne by the Employer and shall be payable by the Contractor himself.</p> <p>III. 100% of applicable Taxes and Duties [other than the Custom duty, IGST and any other levies on imports payable as in para (i) above] which are payable by the Employer under the Contract shall be reimbursed by the Employer to the Contractor/Assignee upon receipt of equipment at site on production of satisfactory documentary evidence by the Contractor/Assignee, as applicable as per relevant GST Laws <u>(Goods and Services Tax (GST) applicable on goods and services specified in Schedule Nos. 2, 3 & 4 shall not be included in respective schedules, but shall be quoted separately in Schedule No. 6).</u></p>

Amendment no. 1 to for NIT No : 40086783

Sl. No.	Reference	Description as mentioned in Bidding Document	Description to be Read as
3.			<p><u>In anywhere in tender document, for the word "Price Schedule" and/or "Price Schedule Version 1", the words "Price Schedule Version 2" shall be substituted.</u></p> <p><u>"Price Schedule Version 2" has been posted in amendment folder under C-Folder.</u></p>

Schedule No.: 1 Item/hardware/software to be supplied from Abroad (per Unit)

SL. NO.	DESCRIPTION	UNIT	QTY	UNIT PRICE (IN FIGURES) CIF(INDIAN PORT OF ENTRY)*	UNIT PRICE (IN WORDS) CIF(INDIAN PORT OF ENTRY)**	TOTAL PRICE CIF(INDIAN PORT OF ENTRY)	CURRENCY***	COUNTRY OF ORIGIN
1		2	3	4	5	6=5x4		
1	Item/Hardware & Software for APC for each 500 MW unit	Lot	1			0		
TOTAL (FOREIGN CURRENCY 1)								
TOTAL (FOREIGN CURRENCY 2)								
TOTAL (FOREIGN CURRENCY 3)								

*Pleas fill in the amount in figures

**Please fill in the amount in words.

***Please state the currency .

SL. NO.	DESCRIPTION	PRICE*	PRICE (IN WORDS)**	CURRENCY***
1	Local Agent's Commission (if any) (included in CIF Price indicated above)			

NOTE

1 Bidder is required to quote the unit rate along with Currency and calculate the sub-total and Total.

2 Bidder is required to indicate the Total of Schedule-1 in "Item Details" Tab of E-Tender Site.

3 Please enter a code representing the country of origin of all imported plant and equipment.

4 Items listed above but priced in Schedule 2 will be struck off by the Bidders in this Schedule 1 (FOREIGN CURRENCY 1),Schedule 1 (FOREIGN CURRENCY 2),Schedule 1 (FOREIGN CURRENCY 3).

Schedule No. 2: Item/hardware/software to be supplied from within the Employer's Country (per Unit)

ITEM	DESCRIPTION	UNIT	QTY	UNIT EX-WORKS (INDIA) PRICE (IN FIGURES)*	UNIT EX-WORKS (INDIA) PRICE (IN WORDS)**	TOTAL EX-WORKS (INDIA) PRICE	CURRENCY
1		2	3	4	5	6=5x4	
1	Item/Hardware & Software for APC for each 500 MW unit	Lot	1				0 INR
TOTAL OF SUB TOTAL						0 INR	

*Please fill in the amount in figures.

**Please fill in the amount in words.

***Please state the currency .

NOTE

- 1 Bidder is required to quote the unit rate along with Currency and calculate the sub-total and Total.
- 2 Bidder is required to indicate the Total of Schedule-2 in "Item Details" Tab of E-Tender Site.
- 3 Please state the currency and fill in the amount in figures and words.
- 4 Items listed above but priced in Schedule 1 will be struck off by the Bidders in this Schedule 2.

Schedule No. 3 Local Transportation including Port handling, Port clearance, Port charges, Inland insurance and other local costs incidental to delivery of Item/Equipment and Mandatory Spares (per Unit)

Sl. No.	Description	UNIT	QTY	Unit Price INR (IN FIGURES)***	Unit Price in INR (IN WORDS)**	Total Price INR	Remarks
1						6=4X5	
1	Item/Hardware & Software for APC for each 500 MW unit						
	GRAND TOTAL Schedule-3 (To be filled up in Item Data)	LOT		1		0	

**Please fill in the amount in words.

***Please fill in the amount in figures.

NOTE

1 Bidder is required to indicate the Total of Schedule-3 in "Item Details" Tab of E-Tender Site.

If, Local Transportation, Inland Transit Insurance, Port Clearance, Port Handling and Port Charges, Custom reconciliation and other local costs incidental to delivery of the Equipment including Mandatory Spares shall be quoted in Schedule-3. The service tax and other taxes / duties / levies & charges, if any for such services payable in the Employer's country is included in quoted price in schedule 1 and/or 2 schedule 2, no price should be quoted in schedule 3.

Schedule No. 4: Installation Services, Training, Handholding and Tuning services, SAT, Insurance covers other than inland transit insurance and other services as specified in the bidding documents (per Unit)

SI. No.	DESCRIPTION	UNIT	QTY	UNIT PRICE (IN FIGURES) *	UNIT PRICE (IN WORDS)**	TOTAL PRICE	CURRENCY ***
1	2	3	4	5		6=5*4	
1	Installation Services for APC for each 500 MW unit	LOT	1			0	
6	AMC for 12 quarters after the completion of warranty period for APC for each 500 MW unit	LOT	1			0	
TOTAL						0	
TOTAL (FOREIGN CURRENCY 1)							
TOTAL (FOREIGN CURRENCY 2)							
TOTAL (FOREIGN CURRENCY 3)							

*Please fill in the amount in figures.

**Please fill in the amount in words.

***Please state the currency .

NOTE

- 1 The rates quoted by the bidder in Schedule-4 will be inclusive of all taxes, duties & levies including service tax & cess thereon payable in Employer's country, as on 7 days prior to the deadline for submission of bids.
- 2 Bidder is required to quote the unit rate along with Currency and calculate the sub-total and Total.
- 3 Bidder is required to indicate the Total of Schedule-4, Schedule-4 (FOREIGN CURRENCY 1), Schedule-4 (FOREIGN CURRENCY 2), Schedule-4 (FOREIGN CURRENCY 3) in "Item Details" Tab of E-Tender Site.
- 4 In case the quoted price for Annual Maintenance Contract (AMC) for 03 (three) years is less than 5% of total awarded package price (excluding tax), then an amount equal to the 'difference of (5% of total package price) and quoted price for (AMC for 03 (three) years)' shall be retained from the supply bills as "Retained Amount" and same shall be released proportionately along with quarterly AMC payment.

Schedule No. 5:

NOT APPLICABLE FOR THIS TENDER

Schedule No. 6 : Goods and Services Tax (GST) applicable on goods and services specified in Schedule Nos. 2, 3 & 4 in respect of direct transactions between Bidder and Employer, not included in the bid price (per Unit)

The details of taxes and duties applicable as on seven (7) days prior to last date for submission of bid, which may be payable by Employer in accordance with the provisions of bidding documents are as under :

Against one particular product description, if multiple taxes/duties/levies are applicable, add same product description in multiple line for each tax/duty/levy.

A: Goods and Services Tax (GST) applicable on goods and services specified in Schedule Nos. 2, 3 & 4 in respect of direct transactions between Bidder and Employer, not included in the Bid Price.

Sl. No.	Description of Taxes/Duties/ Levies etc.	Rate of Tax/Duty/Levy applicable (%)	Amount (in bid currency) on which		Taxes/Duties/Levies payable (Indian Rs.)		Total Taxes/Duties/Levies
			Main Equipments	Mandatory Spares	Main Equipments	Mandatory Spares	
under Schedule No. 2							
	GST						
under Schedule No. 3							
	GST						
under Schedule No. 4							
	GST						
TOTAL							

B: Goods and Services Tax (GST) applicable on goods and services specified in Schedule Nos. 2, 3 & 4 in respect of Bought Out items (to be dispatched directly from Sub-vendor's works to NTPC Site), not included in the Bid Price.)

Sl. No.	Description of Taxes/Duties/ Levies etc.	Rate of Tax/Duty/Levy applicable (%)	Amount (in bid currency) on which		Taxes/Duties/Levies payable (Indian Rs.)		Total Taxes/Duties/Levies
			Main Equipments	Mandatory Spares	Main Equipments	Mandatory Spares	
under Schedule No. 2							
	GST						
under Schedule No. 3							
	GST						
under Schedule No. 4							
	GST						
TOTAL							

Schedule No. 7:

NOT APPLICABLE FOR THIS TENDER

