



**ENQUIRY**

TWO PART BID

BPC 0007

E-TENDER

**भारत हेवी इलेक्ट्रिकल्स लिमिटेड, पिपलानी, भोपाल- ४६२०२२ (भारत)**

**सामग्री प्रबंधन विभाग**

**BHARAT HEAVY ELECTRICALS LIMITED, PIPLANI, BHOPAL-462022 (INDIA).**

**MATERIALS MANAGEMENT DIVISION**

TIN NO- 23573000001

ECC NO- AAACB4146PXM009

MPCT NO- HEL/05/01/0001/S15/11/79

PHONE NO : 91-755-2500100

FAX : 91-755-2500023

www.bhel.com

ENQUIRY NO E1123157

ENQUIRY DATE 26/08/22

ENQUIRY DUE DATE 26/09/22

**ENQUIRY**

SUPP NAME AND ADDRESS	SUPP CODE	REV CD	REV NO	REV DATE	NO OF CATY2	NO OF CATY3	ENQ NO OF ITEMS	INDENT NO
	0	1	0	NA	3	3	3	240322057
	GUARANTEE CERTIFICATE		Y	SUPPLY CONDITION		SUITABLY PACKED IN ALL WEATHER PACKING T O AVOID DAMAGE DURING TRANSIT.		
	TEST CERTIFICATE		Y	TECHNICAL CONDITION		AS PER DRAWINGS, PRODUCT STANDARD, QA PLAN QSP/HG/ 104 REV01 AND TPQR.		
	INSTRUCTION BOOKLET		N	INSPECTION CONDITION		BHEL / CUSTOMER / THIRD PARTY		
	SAMPLE		N					
	GATE PASS		Y					

NOTE: QUOTE PRICE BOTH IN FIGURES & WORDS. IN CASE OF MISMATCH PRICE IN WORDS WILL BE VALID, QUOTATIONS NOT BEARING ENQUIRY NO AND DUE DATE LIABLE TO BE REJECTED.

SL NO	MATERIAL CODE	DESC	UNIT	ITEM QTY	QTY VR%	LOT NO	LOT QTY	DEST	DELIVERY DATE
1	HG4303288012	BOTTOM SHAFT FORGING FOR KODAYAR RMU AS PER DRAWING NO. 22540120702 REV.00, PRODUCT STANDARD HG-10035 REV-07, QA PLAN QSP/HG/104 REV01 AND TPQR HGG-2213. BEFORE START OF MANUFACTURING, SUPPLIER TO CONFIRM LATEST REVISION OF DRAWING FROM HGE.	NO	1.000	0	1	1.000	203	30/11/22
2	HG4303288020	TOP SHAFT FORGING FOR KODAYAR HEP AS PER DRAWING NO. 22540120701 REV.00, PRODUCT STANDARD HG-10035 REV-07, QA PLAN QSP/HG/104 REV01 AND TPQR HGG-2213. BEFORE START OF MANUFACTURING, SUPPLIER TO CONFIRM LATEST REVISION OF DRAWING FROM HGE.	NO	1.000	0	1	1.000	203	30/11/22
3	HG4303288039	THRUST COLLAR FORGING FOR KODAYAR HEP AS PER DRAWING NO. 32540120701 REV.00, PRODUCT STANDARD HG-10035 REV-07, QA PLAN QSP/HG/104 REV01 AND TPQR HGG-2213. BEFORE START OF MANUFACTURING, SUPPLIER TO CONFIRM LATEST REVISION OF DRAWING FROM HGE.	NO	1.000	0	1	1.000	203	30/11/22

**REMARK** [1] THIS IS AN E-TENDER ENQUIRY AND OFFERS TO BE SUBMITTED ON-LINE IN TWO PART BID SYSTEM THROUGH [HTTPS://EPROCUREBHEL.CO.IN](https://eprocurebhel.co.in). BY THE ELIGIBLE SUPPLIERS WHO FULFILLS TECHNICAL PRE-QUALIFICATION REQUIREMENTS (T-PQR :- HGG - 2213 REV.00). [2] BHEL'S STD. PENALTY CLAUSE APPLICABLE AS PER ANNEXURE-B. [3] SUPPLIERS MUST SUBMIT COMPLETELY FILLED & DULY SIGNED/STAMPED "ANNEXURE - B", PEBC CERTIFICATE (ANNEXURE - I/II) ALONG-WITH THEIR OFFER. [4] BHEL STD T&C BP 200102A, MM5527, MM5533 [AS AVAILABLE AT [WWW.BHELBP.CO.IN](http://WWW.BHELBP.CO.IN)]] ARE APPLICABLE. [5] BIDDER TO DECLARE WHETHER OTHER FAMILY FIRMS OR SISTER CONCERN AFFILIATES / SUBSIDIARY FIRMS ARE PARTICIPATING IN THE SAME TENDER [6] THE INSPECTION SHALL BE CARRIED OUT BY TPI / BHEL /CUSTOMER. BIDDER SHALL QUOTE THE PRICE INCLUSIVE OF THIRD PARTY INSPECTION (TPI) CHARGES AND HENCE CHARGES TO BE SHOWN SEPARATELY. VENDOR TO SUBMIT THIRD PARTY INSPECTION CERTIFICATE ALONG WITH TC FOR VERIFICATION BEFORE DESPATCH. [8] INTERNATIONALLY RECOGNISED TPI AGENCIES I.E. LLOYDS/TUV/SGS. SUPPLIERS CAN OPT FROM THESE AGENCIES. [9] ADDITIONAL REQUIREMENT AS PER CUSTOMER APPROVED QA PLAN, IF ANY, SHALL BE INFORMED, ON APPROVAL OF CUSTOMER QA PLAN. [10] THIS TENDER IS TO BE REVERSE AUCTIONED. HENCE, RA CONFIRMATION BY BIDDER IS REQUIRED.

NOTE: BHEL, BHOPAL'S Standard Terms & Conditions BP200102 (Latest Revision) form a part of this Enquiry. Bidders may obtain from us copies of these terms and conditions if not already available.

**Note:** During Bid Evaluation, No loading of price with regard to preferential payment of within 45 days will be made on vendore falling under MSMED ACT - OCT 06

Please submit your lowest quotation in sealed envelop essentially superscribed with ENQUIRY NO, DUE DATE AND PARTY'S NAME so as to reach at TENDER ROOM, GROUND FLOOR, ADM BUILDING, BHEL, PIPLANI BHOPAL-462022 by 11.00 am of due date.

**SPECIAL REMARK:** Bid to be submitted through e-procurement. Refer eproc link on BHEL Bhopal B2B site.

Documents Enclosed

1. Drawing.
2. Catalogue.
3. Purchase specification.
4. Quality Surveillance Plan.

NAME : SHRI DAMODAR SOREN

DESG : MANAGER

0755-2505258

dsoren@bhel.in

**दामोदर सोरेन / DAMODAR SOREN**  
**प्रबंधक / Manager**  
 सामग्री प्रबंधन - ई. एम. / MM-EM  
 बी.एच.ई.एल. भोपाल / B.H.E.L., BHOPAL



ENQUIRY

TWO PART BID

BPC 0007

E-TENDER

भारत हेवी इलेक्ट्रिकल्स लिमिटेड, पिपलानी, भोपाल- ४६२०२२ (भारत)

सामग्री प्रबंधन विभाग

BHARAT HEAVY ELECTRICALS LIMITED, PIPLANI, BHOPAL-462022 (INDIA)

MATERIALS MANAGEMENT DIVISION

TIN NO- 23573000001

ECC NO- AAACB4146PXM009

MPCT NO- HEL/05/01/0001/S15/11/79

PHONE NO : 91-755-2500100

FAX : 91-755-2500023

www.bhel.com

ENQUIRY NO E1123157

ENQUIRY DATE 26/08/22

ENQUIRY DUE DATE 26/09/22

E  
N  
Q  
U  
I  
R  
Y

DRAWING Y PURCH SPEC Y CATALOUGE N Quality Surveillance Plan Y TWO PART BID Y

NOTE: BHEL, BHOPAL'S Standard Terms &amp; Conditions BP200102 (Latest Revision) form a part of this Enquiry. Bidders may obtain from us copies of these terms and conditions if not already available.

**Note:** During Bid Evaluation, No loading of price with regard to preferential payment of within 45 days will be made on vendore falling under MSMED ACT - OCT 06

Please submit your lowest quotation in sealed envelop essentially superscribed with ENQUIRY NO, DUE DATE AND PARTY'S NAME so as to reach at TENDER ROOM, GROUND FLOOR, ADM BUILDING, BHEL, PIPLANI BHOPAL-462022 by 11.00 am of due date.

SPECIAL REMARK: Bid to be submitted through e-procurement. Refer eproc link on BHEL Bhopal B2B site.

Documents Enclosed

1. Drawing. 3. Purchase specification.  
2. Catalogue. 4. Quality Surveillance Plan.

NAME : SHRI DAMODAR SOREN

DESG : MANAGER

0755-2505258

dsoren@bhel.in

1. This is only a request for Quotation & not an order.
2. Small Scale industries should indicate SSI Regn. No. in Quotation/invoice.
3. In case you are not making an offer against this Enquiry, we request you to post a regret letter.
4. Indian vendors to please indicate GSTIN on their quotation.

दामोदर सोरेन / Manager  
 प्रबंधक / Manager  
 सामग्री प्रबंधन - ई. एम. / MM-EM  
 बी.एच.ई.एल., भोपाल / B.H.E.L., BHOPAL

[ANNEXURE-B]

Enquiry No. E1123157 /PI No: 240322057, ITEM: Top Shaft Forging, Bottom Shaft Forging & Thrust Collar Forging

**IMPORTANT: [1] Suppliers to ensure submission of completely filled & duly signed/stamped "Annexure-B" along-with the Offer.**

Sl no	IMPORTANT INSTRUCTIONS FOR TENDERER	
❖	BHEL's Parameter	Accepted/Deviation
1	<p><b>BHEL's Standard Payment Terms: - A.</b> PQC condition related to Financial PQR. Financial PQR- Average Turnover of the bidders for last three financial year ending 31/03/2021 ( In case of foreign bidders corresponding financial year adopted) shall be equivalent to INR 22,50,000 (Rupees Twenty Two Lakhs Fifty Thousand). In case of foreign bidders, for conversion to INR, TT selling Exchange rate as on tender due date shall be considered. <b>Indigenous Bidders</b> -Audited P&amp;L and Balance sheet of above mentioned Three Financial Year last Three Financial Year to be submitted. <b>Foreign bidders</b>- Audited P&amp;L and Balance sheet of above mentioned Three Financial Year Or Business Information Report (BIR) by D&amp;B specifying turnover of above mentioned Three Financial Year or Turnover above mentioned Three Financial Year duly certified by their statutory auditors is to be submitted.</p>	
2	<p><b>Tax and Duties:</b> <b>Foreign Bidders</b> : The offered prices in case of foreign bidders shall be inclusive of all the Taxes and duties as applicable in the country of bidder / country of dispatch for the quoted CFR / CIF price. Foreign bidders to submit declaration of Permanent Establishment and Business Connection (PEBC) for remittances and Tax Residency Certificate (TRC) &amp; Form 10F (for obtaining DTAA benefits). GST/ Income Tax TDS applicable as per Law shall be deducted. <b>Indigenous Bidders</b> -Bidders to ensure timely remittance of SGST, CGST , IGST as applicable in time as per law. Vendor to ensure compliance to timely filing of monthly GST return. GST portion of invoice shall be released only upon the invoice being reflected in GSTR 2A of BHEL and invoices being compliant to GST Invoice rules. GST/ Income Tax TDS applicable as per Law shall be deducted.</p>	

3	<p><b>C. Payment Terms :</b></p> <p><b>Foreign Bidders:</b> 100% against irrevocable, unconfirmed LC, payable within 90 days of the Bill of Lading (B/L) date or Payment terms of CAD payable on 90th day of B/L / AWB</p> <p>Any deviation from the above payment terms, if accepted (by BHEL), shall be loaded @ SBI base rate + 6% for the purpose of bid evaluation.</p> <p><b>Indigenous Bidders:</b> 100% payment in 90 days of receipt (45 days for MSE including NSIC/ Udyog Aadhar/Udyam registered suppliers as per relevant act in force) of material, subject to acceptance of material at BHEL, on direct presentation of the documents.</p> <p>In case of despatch of material to site directly, payment as per above terms shall be made from the date of receipted LR.</p> <p>Any deviation from the above payment terms, if accepted (by BHEL), shall be loaded @ SBI base rate + 6% for the purpose of bid evaluation.</p>	
4	<p><b>D. Delivery Schedule / LD applicability.</b></p> <p>Subject to force Majeure condition: Penalty shall be 0.5% of the total order value per week of delay or part thereof, subject a maximum of 10% of the total order value. Total order value above shall be item wise, lot wise order value.</p> <p><b>Foreign Bidders-</b> The date of Bill of Lading (B/L) or AWB shall be taken as actual date of delivery.</p> <p><b>Indigenous Bidders-:</b> LR date in case of ex-works and UMID in case of FOR destination shall be taken as actual date of delivery.</p>	
5	<p><b>Document for Foreign Bidder:</b></p> <p>1. Seller shall send 1 set of original negotiable documents Comprising of Bill of Lading/AWB, Invoice &amp; Packing List, in English, within 7 days of B/L date / 1 day of AWB date by DHL/courier and also share documents through email to fin_fp.bpl@bhel.in &amp; mmfe.bpl@bhel.in &amp; msair@bhel.in &amp; mssea@bhel.in within 1 days of dispatch</p>	
	<p>2. One Original Negotiable Set of Clean on Board Freight Prepaid (In Case of CIF/CIP/CFR) / To Pay (In Case Of Ex-Works/FOB/FCA) Combined Transport Bill of Lading/AWB Showing Beneficiary as Shipper and Govt. of India on Behalf of Bharat Heavy Electricals Limited, Bhopal as Consignee and Notify: BHEL ROD Mumbai, 14th Floor. World Trade Centre-1, Cuffe Parade Colaba, Mumbai 400005 India. Phone No +91 22 22171345/22171346/22171370</p>	
	<p>3. One Set of Original Negotiable Invoice and Packing List indicating container-wise Gross weight, Net weight, CBM volume, No. of packages with dimensions of each package.</p>	
	<p><b>4. COO :</b> Original Certificate of Country of Origin (COO) issued by Chamber of Commerce</p>	

	<p><b>5.</b> Original One set of Original Test Certificate / Certificate of Conformity / Inspection Certificate / Third Party Inspection Certificate / Calibration Certificate, etc as applicable, is to be submitted by Seller. If Seller and OEM and different, then Test Certificate/ Calibration Certificate/Third Party Inspection Certificate, etc as applicable, from OEM will be also be submitted by Seller. O&amp;M Manual where called for, shall be submitted by Seller.</p>	
	<p><b>6. Packing :</b> Seller's declaration that wood- packing material used in packing is in accordance with IPPC standard ISPM no.15 and has been labelled compliant with IPPC mark by manufacturers or beneficiary's declaration that wood- packing material has not been used in packing of the goods.</p>	
	<p><b>7. Pre Dispatch Clearance (PDC) :</b> PDC issued by BHEL referencing Original Test Certificate / Certificate of Conformity / Inspection Certificate / Third Party Inspection Certificate / Calibration Certificate No., etc., as applicable, and their dates</p>	
	<p><b>8. Permanent Establishment Business Certificate (PEBC) :</b> PEBC as per Annexure A / B Clause 16C of GTC, as applicable. In case of Services, additionally Form 10 F of Income Tax Act, 1961 and Tax Residency Country (TRC) of Seller's Country is required, as per Clause 16D of GTC.</p>	
	<p><b>9.</b> Supplier should additionally forward TWO sets of above original negotiable documents (Sl 1 to 11) through DHL / Registered airmail or AWB by captain's mail within three days OF OBL/AWB Date to each of the following :- (I)AGM(CMM-FE), BHEL,2<sup>nd</sup>. Floor, Adm. Building,Piplani, Bhopal-462022,India. (II)AGM (ROD, BHEL Mumbai), BHEL, ROD, 14TH Floor, World Trade Centre-1, Cuffe Parade, Colaba, Mumbai - 400005. Phone / MOB. NO.: 022-22171301 Email Intimation of the above to be sent to fin_fp.bpl@bhel.in, fin_fp.bpl@bhel.in &amp; mmfe.bpl@bhel.in &amp; msair@bhel.in &amp; mssea@bhel.in</p>	
	<p><b>10. Guarantee/ Warranty Certificate :</b> As Applicable, Issued by Seller in One Original. If Seller and OEM and different, Guarantee/ Warranty Certificate, as applicable, from OEM will be also be submitted by Seller.</p>	
	<p><b>11. Certificate from Shipping company</b> or its agent or its owner or master or charterer stating that the carrying vessel is seaworthy and the vessel is classified by an approved classification society as per institute classification clauses and classified as Lloyds 100 A1 or its equivalent classification stating that the vessel is not more than 25 years old.</p>	

	<b>12. Marine/Air Insurance policy</b> : Policy or certificate, blank endorsed, dated not later than the date of OBL/AWB, full set in the negotiable form in the currency of credit covering 110% of the Invoice value. Insurance to include institute cargo clauses (a), Institute war clauses (marine cargo) and institute strike clauses (marine cargo) with claims payable in India. Insurance to cover from supplier's warehouse to JNPT Nhava Sheva Mumbai / Mumbai seaport / Mumbai airport/ ICD, Mandideep, as applicable.	
	<b>13. The Destination Terminal Handling Charges (DTHC)</b> : DTHC will be paid by BHEL directly to the terminal and same will not be paid to the shipping line of vendor. If shipping Line charges the dthc to bhel, the same along with any additional/consequential expenses incurred (like detention/ demurrage, ground rent, penalty, etc) will be recoverable from beneficiary's bills confirmed via seller's/beneficiary bank swift	
	14. If seller/beneficiary does not comply or deviates from any of the above clauses/compliances, then any additional charges, demurrage, detention, ground rent, clearance charges, penalty, etc imposed on or borne by/paid to BHEL due to such non-compliance/deviation, etc., shall be to the account of the seller/beneficiary and shall be recoverable from the seller's/beneficiary's bills Confirmed via seller's/beneficiary bank swift.	
	<b>15. Intimation of Dispatch</b> : Beneficiary to send email intimation about dispatch of goods giving details of OBL/AWB no. & its date, BHEL purchase order number, invoice no. & its date, currency & invoice value, packing list, PDCC ref no. & date, LC no., seller's bank reference no., if & as applicable to fin_fp.bpl@bhel.in & mmfe.bpl@bhel.in & msair@bhel.in & mssea@bhel.in	
	16. Other documents, as required, will be separately indicated in the Purchase Order. Additional expenditure, if any, incurred by the Purchaser by way of detention / demurrage, resulting out of delay attributable to the Seller in providing Negotiable documents, will be recovered from the Seller.	
	17. In case the Seller decides to negotiate all 3 originals of B/L / AWB along with all original documents through negotiating Bank, non-negotiable documents (NNDs) consisting of copy of B/L / AWB & documents mentioned at Sl. no. 11- B2 to B5 will be sent by e-mail to the Purchaser at his e-mail address given in the PO.	
6	Applicable BHEL Conciliation Scheme : Enclosed	
7	<b>Preference to Make in India:</b> For this procurement, Public Procurement (Preference to Make in India), order 2017 dated 15.06.2017 & 28.05.2018 and subsequent orders issued by the respective Nodal ministry shall be applicable even if issued after issue of this NIT but before finalization of contract/PO/WO against this NIT. In the event of any Nodal Ministry prescribing higher or lower percentage of purchase preference and/ or local content in respect of this procurement, same shall be applicable. Default margin of purchase preference shall be 20% to local suppliers with default minimum local content of 50%.	
8	<b>Type of GST applicable – IGST / CGST_SGST with percentage</b>	
9	<b>HSN code of item.</b>	
10	<b>Delivery Schedule:</b> To be quoted in weeks from the date of P.O.	

11	<b>Terms &amp; Conditions:-</b> BHEL STD T&C BP 200102A,MM5527,MM5533 [as available at <a href="http://www.bhelbpl.co.in">www.bhelbpl.co.in</a> ] are applicable.	
12	The bidder / supplier /contractor will, when presenting his bid, declare whether other family firms or sister concern affiliates / subsidiary firms are participating in the same tender or not.	
13	<b>Offer Validity:</b> 90 days from the date of Tender opening.	
14	<b>Prices :</b> 'Firm Price'	
15	<b>Reverse auction:</b> BHEL shall be resorting to Reverse Auction (RA) (Guidelines as available on <a href="http://www.bhel.com">www.bhel.com</a> ) for this tender. RA shall be conducted among all the techno-commercially qualified bidders. Price bids of all techno-commercially qualified bidders shall be opened and same shall be considered for RA. In case any bidder(s) do(es) not participate in online Reverse Auction, their sealed envelope price bid along with applicable loading, if any, shall be considered for ranking."	
16	<b>Delivery terms for indigenous supply :</b> <u>F.O.R. BHEL Bhopal</u> (All freight & Insurance charges shall be borne by Supplier)	
17	<b>Delivery terms for Foreign supply :</b> CIF, Mumbai Port	
18	For General Terms & Conditions, Clause P for case where more than one offer is L-1, the following supersedes the Clause P and will prevail :- "In the course of evaluation, if more than 1 bidder happens to occupy L-1 status, effective L-1 will be decided by soliciting discounts from the respective L-1 bidders. In case more than 1 bidder happens to occupy the L-1 status even after soliciting discounts, the L-1 bidder shall be decided by a toss/ draw of lots, in the presence of the respective L1 Bidder(s) or their representative(s). Ranking will be done accordingly. BHEL's decision in such situations will be final and binding"	
19	<b>Contact Person &amp; details ( email &amp; telephone no )</b>	



**SPECIFICATION FOR SHAFT/THRUST COLLAR FORGINGS FOR  
HYDROGENERATOR**

**1. GENERAL:**

**1.1** Shaft/ Thrust collar forgings for Hydrogenerators shall be procured in rough machined condition, as per requirements given in this specification and forging drawing made for individual project.

**2. CONDITION OF DELIVERY :**

Normalised/ Normalised & Tempered.

Rough machining of the forgings shall be carried out unless otherwise specified on the order/drawing.

**3. DIMENSION AND TOLERANCES :**

The dimensions and tolerances shall be as specified on the order/drawing. Wherever these are not specified, the machining allowances and tolerances shall be as specified below :

For rough machined drawings: +2/-0 on outside diameter and +0/-2 on inside diameter.

**4. MANUFACTURE :**

Forgings shall be manufactured from steel produced by the open hearth, electric or such other process as may be agreed to between BHEL and the manufacturer.

The steel for this forging shall be vacuum degassed to protect the forgings from harmful effects of hydrogen and other gases.

The steel shall be fully killed. Sufficient discard shall be made from each ingot to ensure freedom from pipe, segregation and other defects.

The amount of hot working and finishing temperature shall be such as to ensure complete soundness and adequate uniformity of structure and mechanical properties after heat treatment. The forgings shall not be overheated.

The minimum reduction ratio when forgings are made out of ingots shall be 4:1, for all ruling sections unless otherwise agreed between BHEL & supplier before placement of order.

गोपनीय एवं अधिकार सुरक्षित  
इस प्रपत्रा पर दी गई जानकारी भारत हेवी इलेक्ट्रिकल्स लिमिटेड की सम्पत्ति है इसे प्रत्यक्ष या अप्रत्यक्ष रूप से कम्पनी के हितों को नुकसान पहुँचाने के लिए कदापि उपयोग नहीं किया जावे

संशोधन : 07

हाइड्रोजनरेटर इंजीनियरिंग विभाग  
भारत हेवी इलेक्ट्रिकल्स लिमिटेड

*[Handwritten signatures and dates]*  
11/12/2015  
(KRISHNA CB) Ritesh  
Ajshikye  
(B.K.SINGH)

तैयारकर्ता

अनुमोदनकर्ता

जारी करने की दिनांक

-Sd-  
H.S.DUGGAL

-Sd-  
M.C.NATH

19/06/2001

**5. HEAT TREATMENT :**

Forgings shall be normalised at suitable temperature to give the mechanical properties specified.

**6. FINISH:**

As mentioned in the drawing.

**7. FREEDOM FROM DEFECTS :**

Forgings shall be free from defects such as cracks, flakes, seams, segregation, harmful non-metallic inclusions and other defects which may affect the utility of the forgings.

**8. CHEMICAL COMPOSITION :**

The melt analysis of steel and permissible variation in the composition of the forgings from the melt analysis shall be as follows:

Element	Melt analysis Percent		Permissible Variation, Percent
	Min.	Max.	
Carbon	0.24	0.32	± 0.02
Silicon	0.10	0.35	± 0.03
Manganese	1.30	1.70	± 0.10
Sulphur	--	0.035	+ 0.006
Phosphorus	--	0.035	+ 0.006

**Notes :**

Elements not quoted above shall not be added to the steel, other than for the purpose of finishing the heat and shall not exceed the following limits:

Element	Percent, Max.
Nickel	0.30
Chromium	0.30
Copper	0.30
Molybdenum	0.15
Vanadium	0.05
Tin	0.05

गोपनीय एवं अधिकार सुरक्षित  
 इस प्रपत्रा पर दी गई जानकारी भारत हेवी इलेक्ट्रिकल्स लिमिटेड की संपत्ति है इसे प्रत्यक्ष या अप्रत्यक्ष रूप से कम्पनी के हितों को नुकसान पहुंचाने के लिए कदापि उपयोग नहीं किया जावे

गोपनीय एवं अधिकार सुरक्षित  
 इस प्रपत्रा पर दी गई जानकारी भारत हेवी इलेक्ट्रिकल्स लिमिटेड की सम्पत्ति है इसे प्रत्यक्ष या अप्रत्यक्ष रूप से कम्पनी के हितों को नुकसान पहुँचाने के लिए कदापि उपयोग नहीं किया जावे

**9. TEST SAMPLES:**

**9.1** Test samples should be cut from the heat treated forgings by cold process only and shall receive no further heat treatment.

Test samples shall be cylindrical in shape.

- (a) Radial test piece shall be taken from one end of the forging.
- (b) Tangential test piece shall be taken from other end of the forging.
- (c) Test piece diameter shall be 16mm min. (as per IS-1608:1995, amd. No. 1, May2002, table5)

Test piece shall be cut as below:

- (i) For solid forgings: At a distance of one – third radius or one-sixth diagonal from the outer surface.
- (ii) For hollow forgings: Midway between the inner and outer surface of the wall thickness.

**10. MECHANICAL PROPERTIES:**

The test pieces shall show the following properties for all ruling sections. Test methods are specified below:

<b>10.1</b>	Tensile test	: IS: 1608
<b>10.2</b>	Hardness test (Brinell)	: IS: 1500
<b>10.3</b>	Charpy Impact Value (2mm U-Notch)	: IS: 1499
<b>10.4</b>	Mechanical properties	
	<b>i.</b> Tensile strength (in any direction)	560 N/mm <sup>2</sup> Min
	<b>ii.</b> Yield strength (in any direction)	335 N/mm <sup>2</sup> Min
	<b>iii.</b> Elongation 5.65 √ so gauge length	Radial - 10% Min Tangential - 12% Min
	<b>iv.</b> Charpy impact value (2 mm U notch)	Radial - 23 joules Min Tangential - 29 joules Min
	<b>v.</b> Hardness (Brinell) for reference only	156 -212

**11. N.D.T.**

**11.1** Each forging shall be tested ultrasonically in accordance with BHEL Standard No. AA0850101 after final completion of all operation on the forging. All transition zones shall be subject to magnetic particle test as per above standard, before application of antirust compound.

**11.2** Boroscopic test for central hole in case of shaft forging shall be carried out to AA0850101 before application of antirust compound.



## 12. TEST CERTIFICATES:

Three copies of test certificates shall be supplied unless otherwise stated on the order. In addition, the supplier shall ensure to enclose one copy of the test certificate along with their dispatch documents to facilitate quick clearance of the material.

The following details shall be furnished in the test certificate

- i) Reduction Ratio.
- ii) Dimensional Inspection.
- iii) Details of heat treatment.
- iv) Chemical composition including trace elements.
- v) Result of mechanical tests.
- vi) Result of ultrasonic test.

## 13. INSPECTION AT SUPPLIER'S WORKS:

Tests and inspection are to be conducted in the presence of purchaser's representative. The representative shall have free access at all times while the work on the contract is being performed. All facilities without charge to be provided to purchaser during inspection including provision of test specimen and its testing. If necessary supplier shall make necessary arrangement for carrying out the test elsewhere.

## 14. REJECTION AND REPLACEMENT:

In the event of any forging proving defective in the course of preparation, machining, testing or erection such forging shall be rejected, notwithstanding any previous certification of satisfactory testing and /or inspection.

The supplier shall undertake to replace the rejected forgings at his own cost and the rejected forgings shall be sent back to the supplier after fulfilling the commercial terms and conditions.

## 15. PACKING AND MARKING :

The shaft forging shall be properly protected with anticorrosive compounds. Forgings shall be suitable packed to prevent corrosion and damage transit.

## 16. DOCUMENT TO BE SUBMITTED ALONG WITH OFFER:

Manufacturing process chart comprising of manufacturing sequence, forging sequence, heat treatment cycle with stage wise test schedule.

**NOTE: WITHOUT THIS DOCUMENT, OFFER WILL BE CONSIDERED INCOMPLETE.**

**Rev. 00 – Prepared by- H.S.Duggal, Approved by- M.C.Nath (19<sup>th</sup> June, 2001)**

**Rev. 01 – Clause 2, 4, 7 & 13 – Modified. Clause 14, 15 & 16 added**

**Rev. 02 – Clause 11.2 added.**

**Rev. 03 – Clause 1.2 modified**

**Rev. 04 – Clause 9 modified (7<sup>th</sup> September, 2004)**

**Rev. 05 – Clause 10.4(iii), (iv) updated (8<sup>th</sup> March,2005 )**

**Rev. 06 – Clause 1.2 deleted**

**Rev. 07 – Clause 10.4.(iv) updated**

इस प्रपत्रा पर दी गई जानकारी भारत हेवी इलेक्ट्रिकल्स लिमिटेड की सम्पत्ति है इसे प्रत्यक्ष या अप्रत्यक्ष रूप से कम्पनी के हितों को नुकसान पहुँचाने के लिए कदापि उपयोग नहीं किया जावे  
पनीय एवं अधिकार सुरक्षित



QGX-8

## QUALITY ASSURANCE DEPARTMENT

QA PLAN FOR: FORGINGS

QA PLAN NO: QSP/HG/104

DATE: 13/10/1993

PI NO: \_\_\_\_\_

REVISION: 01

SHEET 1 of 2

DATE: 14/01/2016

SL. NO.	COMPONENT/ASSY/ OPERATION	CHARACTERISTICS	CLASS	TYPE	QUANTUM OF CHECK	REF. DOC.	RECORD FORMAT	INSPECTION AGENCY	REMARKS
1.0	Forging stock (ingot or bloom)	a) Material certification	Major	Review	100%	Spec/ Drawing	TC	Supplier/BHEL/ Customer	
		b) Material identification	Major	Review	100%	Spec/ Drawing	TC	Supplier/BHEL/ Customer	
1.2	Forging	a) Visual and process checks	Major	Review	100%	Approved forging process	Supplier QC record	Supplier/BHEL/ Customer	
		b) Heat treatment	Critical	Heat treatment	100%	Spec	TC	Supplier/BHEL/ Customer	
		c) Marking of test samples as per drawing	Major	Review	100%	Drawing	Supplier QC record	Supplier/BHEL/ Customer	<b>WITNESS</b>
		d) Chemical analysis	Major	Chem	Sample	Spec	TC	Supplier/BHEL/ Customer	<b>WITNESS</b>
		e) Mechanical analysis	Major	Mech	Sample	Spec	TC	Supplier/BHEL/ Customer	<b>WITNESS</b>
		f) Ensure proof marking for availability of machining allowance	Major	Dimensional	100%	Drawing	Supplier QC record	Supplier/BHEL/ Customer	
		g) Marking of PF nos., etc. before rough machining	Major	Review	100%	Drawing	Supplier QC record	Supplier/BHEL/ Customer	
		h) Visual & dimensional checks of rough machined forgings	Major	Visual/ Dimensional	100%	Drawing	Supplier QC record	Supplier/BHEL/ Customer	<b>WITNESS</b>

PREPARED BY: -SD-

CHECKED BY: -SD-

APPROVED BY: -SD-

DATE: 13/10/1993

REVISION 01: 1) "Important note" has been added. 2) The "Type" field was blank for 1.2 c) & 1.2 g). 3) The "Record format" field was blank for Sl. No. 1.2 c). 4) The format has been updated.

PREPARED BY: *[Signature]* 14/01/2016CHECKED BY: *[Signature]* 14/01/16APPROVED BY: *[Signature]* 15/01/2016

DATE: 14/01/2016

कृष्णा चै. बंडारु

KRISHNA C BANDARU

वरि अभियंता (अभिकल्प) / Sr. Engineer (D)  
एच.जी.ई. प्रभाग / HGE Division  
बी.एच.ई.एल., भोपाल / BHEL, BHOPAL

रितेश गजभिये / RITESH GAJBHIYE

वरि प्रबंधक (अभिकल्प) / Sr. Manager (D)  
एच.जी.ई. प्रभाग / HGE Division  
बी.एच.ई.एल., भोपाल / BHEL, BHOPAL

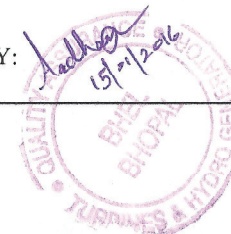



QUALITY ASSURANCE DEPARTMENT

QA PLAN FOR: FORGINGS  
QA PLAN NO: QSP/HG/104

DATE: 13/10/1993

PI NO: \_\_\_\_\_  
REVISION: 01

SHEET 1 of 2  
DATE: 14/01/2016

SL. NO.	COMPONENT/ASSY/ OPERATION	CHARACTERISTICS	CLASS	TYPE	QUANTUM OF CHECK	REF. DOC.	RECORD FORMAT	INSPECTION AGENCY	REMARKS
		i) UT on forging and boroscopic examination	Major	NDT	100%	Drawing	TC	Supplier/BHEL/ Customer	<b>WITNESS</b>
		j) Final marking of PF nos., heat nos., identification, etc.	Major	Review	100%	Drawing	TC	Supplier/BHEL/ Customer	
		k) Painting, preservation, and packing	Major	Review	100%	Drawing	TC	Supplier/BHEL/ Customer	

ABBREVIATIONS: NDT - Non Destructive Testing, Mech - Mechanical, Chem - Chemical, Elec - Electrical, Spec - Specification, TC - Test Certificate, QC - Quality Control

IMPORTANT NOTE: Some of the above-mentioned tests may be witnessed by the customer. This shall be intimated at a later date.

PREPARED BY: -SD-

CHECKED BY: -SD-

APPROVED BY: -SD-

DATE: 13/10/1993

REVISION 01: 1) "Important note" has been added. 2) The "Type" field was blank for 1.2 c) & 1.2 g). 3) The "Record format" field was blank for Sl. No. 1.2 c). 4) The format has been updated.

PREPARED BY: *Krishna C Bandaru* 14/01/2016

CHECKED BY: *Ritesh Gajbhiye* 14/01/2016

APPROVED BY: *[Signature]*

DATE: 14/01/2016

**कृष्णा चै बंडारु**  
KRISHNA C BANDARU  
वरि अभियंता (अभिकल्प) / Sr. Engineer (D)  
एच.जी.ई. प्रभाग / HGE Division  
बी.एच.ई.एल., भोपाल / BHEL, BHOPAL

**रितेश गजभिये / RITESH GAJBHIYE**  
वरि प्रबंधक (अभिकल्प) / Sr. Manager (D)  
एच.जी.ई. प्रभाग / HGE Division  
बी.एच.ई.एल., भोपाल / BHEL, BHOPAL

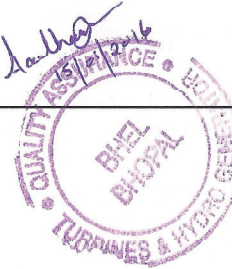

**- ALL INSPECTION INCLUDING WITNESS TESTS SHALL BE INSPECTED BY TPIA (THIRD PARTY INSPECTION AGENCY)**

 <b>BHOPAL</b>	<b>TECHNICAL PRE-QUALIFICATION REQUIREMENTS (TPQR)</b>	<b>DOC. NO.:</b> HGG-2213 <b>DATE:</b> 17-08-2022 <b>REV.:</b> 00 <b>PAGE</b> 01 OF 01
	<b>HYDRO GENERATOR ENGINEERING DIVISION</b>	

The bids are invited from manufacturer or their authorized representative for supply of shaft forging as per BHEL drawing, purchase specification and quality plan.

Following are the Technical Pre-Qualification Requirements (TPQR):

Sr. No.	Description of pre-qualification requirement	Vendor Response	
		Complied/ Not complied	Supporting Documents required to accept compliance
1)	Manufacturer of forging / their authorized representative.		Certificate of being manufacturer (for manufacturer) / authorization (for authorized representative).
2)	Experience of manufacturing steel shaft forging as per HG10035 or equivalent or higher grade (yield point) and supply of the same during last 10 years (see note-3) having following criteria: a) Minimum 3 supplies of individual forging weight of 4000.0 kgs. OR b) Minimum 2 supplies of individual forging weight of 5000 kgs. OR c) Minimum 1 supply of individual forging weight of 8000 kgs.		- Purchase order or - Test certificate & invoice.
3)	Capability of manufacturing shaft & thrust collar forging as per BHEL drawing, specification and QA plan.		Self-certification of having the capability.
4)	Company shall be certified with ISO 9001. In case of authorized representative, valid ISO certificate of manufacturer is required.		Valid certificate to be submitted.
5)	Vendor to confirm its capacity to manufacture of enquired quantity within 5 months of PO. (see note-5)		Supplier confirmation required.

**Note:**

1. Compliance to above Technical Pre-Qualification Requirements are mandatory. In absence of compliance of above requirements vendor TPQ application is liable to be rejected.
2. BHEL has the right to verify information / confirmation furnished, by asking additional documents, proofs etc.
3. The reference date will be the date of enquiry.
4. For each P.O submitted for point no 2 above, Vendor to provide Contact details such as mail-id, address and contact numbers of mentioned customer for verification purpose.
5. The condition mentioned at sr. no. 5 is to ascertain the suppliers manufacturing capacity and the same is not linked with any delivery schedule.

**Prepared By**

**Checked By**

**Approved By**

DRG. NO. 2 254 01 20701

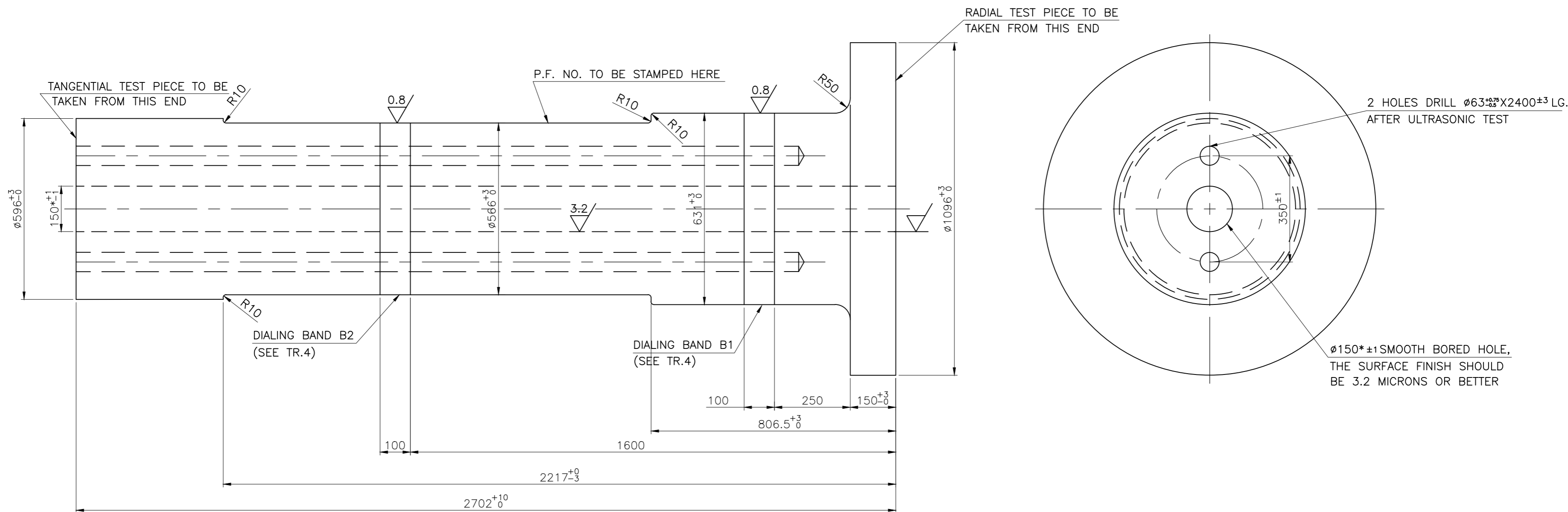

**TECHNICAL REQUIREMENTS:-**

- P.F. NUMBERS TO BE STAMPED AT PLACE SHOWN ON THE DRG. AND RESTAMPED JUST AFTER MACHINING.  

UNIT NO.	P.F. NO.
1.	311569
- SURFACE FINISH OF MACHINED SURFACES SHALL BE 3.2 MICRONS OR BETTER. ALL OVER UNLESS OTHERWISE STATED.
- ALL FACES SHOULD BE PARALLEL & SQUARE TO THE AXIS.
- MACHINING BAND B1 & B2 SHALL BE USED FOR RESETTING SHAFT AT BHEL WORKS. THESE SHALL BE DIALLED WITHIN 0.05 MM.
- SHAFT FORGING INCLUDING BORE TO BE PAINTED WITH ANTI RUST PAINT TO BP0690084.
- 6-COPIES OF TEST CERTIFICATES TO BE SUPPLIED, P.F. NO. OF FORGING AND CAST NO. OF BILLET TO BE QUOTED ON CORRESPONDING COPIES OF TEST CERTIFICATES.
- INSPECTION SHALL BE DONE AS PER CUSTOMER APPROVED QA PLAN.
- WELD, REPAIR & COLD WORKING OF FORGING IS NOT PERMISSIBLE AT ANY STAGE.
- DIMENSIONS MARKED THUS \* ARE FINAL FINISHED AND THESE SHALL BE COAXIAL AND CONCENTRIC (WITHIN 0.05mm). ALSO THESE PORTIONS WILL BE ADEQUATELY PROTECTED TO AVOID DAMAGE DURING TRANSPORTATION/HANDLING.
- INSPECTION SHALL BE CARRIED OUT IN THE PRESENCE OF BHEL/THIRD PARTY/CUSTOMER.

001		TOP SHAFT FORGING		HG10035		6090																						
59	64	65	75	78	79	25	27	29	58	59	60	77	29	31	34	45	55	56	57	58	65	72						
VAR00		REMARKS		VAR. NO.		ITEM NO.		DESCRIPTION		DRAWING NO.		IT.ND.		MATL. CODE		MATL. SPCN.		UNIT WT.		QTY.		ZONE						
28 → CARD TYPE-3				28 → CARD TYPE-1				28 → CARD TYPE-2																				
ADDITIONAL INFORMATION W.O. NO. 30328-A-23154										mRikn dk i-dkj ;k xk-gd@ifj;kstuk dk uke TYPE OF PRODUCT OR NAME OF CUSTOMER/PROJECT																		
STATUS OF DRAWING U										HGT-426/195-12D TANGEDCO/ KODAYAR (RMU)																		
DISTRIBUTION OF PRINTS										<table border="1"> <tr> <td>CUK;k DRN.</td> <td>LU</td> <td>08.06.22</td> </tr> <tr> <td>WPK;CRD.</td> <td>NS</td> <td>08.06.22</td> </tr> <tr> <td>WU;K;S;FR;APPD.</td> <td>RG</td> <td>08.06.22</td> </tr> </table>										CUK;k DRN.	LU	08.06.22	WPK;CRD.	NS	08.06.22	WU;K;S;FR;APPD.	RG	08.06.22
CUK;k DRN.	LU	08.06.22																										
WPK;CRD.	NS	08.06.22																										
WU;K;S;FR;APPD.	RG	08.06.22																										
foHAKx DEPT. HGE dksM CODE 403										<table border="1"> <tr> <td>wu_Vky_uki dh Js.kh</td> <td>UNTOL. DIMS. GR.</td> <td>32500001404</td> </tr> <tr> <td>wuqjkr SCALE</td> <td>1:10</td> <td></td> </tr> <tr> <td>HAK;fd;W;K;S;FR;APPD.</td> <td>6090</td> <td></td> </tr> </table>										wu_Vky_uki dh Js.kh	UNTOL. DIMS. GR.	32500001404	wuqjkr SCALE	1:10		HAK;fd;W;K;S;FR;APPD.	6090	
wu_Vky_uki dh Js.kh	UNTOL. DIMS. GR.	32500001404																										
wuqjkr SCALE	1:10																											
HAK;fd;W;K;S;FR;APPD.	6090																											
'Ah"AZBLE										M&kbox d-@ DRAWING NO. 2 254 01 20701																		
										TOP SHAFT FORGING																		
										=B d- SHT. NO. 01																		

THE INFORMATION ON THIS DOCUMENT IS THE PROPERTY OF BHARAT HEAVY ELECTRICALS LIMITED. IT MUST NOT BE USED DIRECTLY OR INDIRECTLY IN ANY WAY DETRIMENTAL TO THE INTEREST OF THE COMPANY.

REF. DRG. NO.

SIGN AND DATE

INVENTORY NO.

DRG. NO. 2 254 01 20702

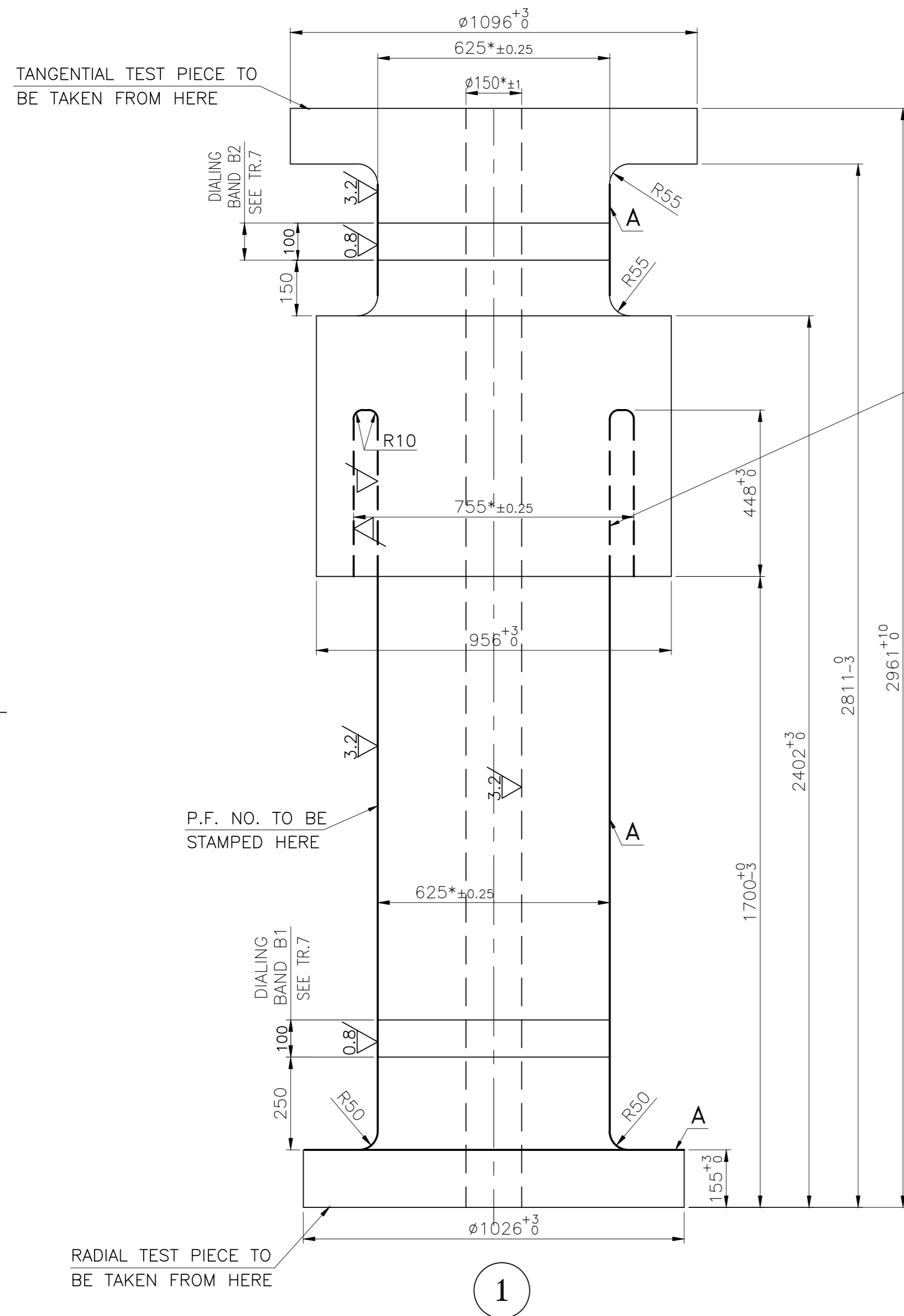

**TECHNICAL REQUIREMENTS:-**

- P.F. NUMBERS TO BE STAMPED AT PLACE SHOWN ON THE DRG. AND RESTAMPED JUST AFTER MACHINING.  
UNIT NO. 1. P.F. NO. 311568
- SURFACE FINISH OF MACHINED SURFACES SHALL BE 3.2 MICRONS OR BETTER. ALL OVER UNLESS OTHERWISE STATED.
- ALL FACES SHOULD BE PARALLEL & SQUARE TO THE AXIS OF THE SHAFT.
- ALL SURFACES, INCLUDING THE BORE, SHALL BE ADEQUATELY COATED WITH A SUITABLE ANTI-RUST COATING (EQUIVALENT TO OR BETTER THAN BP0690084).
- DIAMETRIC DIMENSIONS MARKED THUS \* AND PORTION OF SHAFT MARKED 'A' ARE FINAL FINISHED AND THESE SHALL BE COAXIAL AND CONCENTRIC (WITHIN 0.05mm). ALSO THESE PORTIONS WILL BE ADEQUATELY PROTECTED TO AVOID DAMAGE DURING TRANSPORTATION/HANDLING.CERTIFICATES.
- WELD REPAIR & COLD WORKING OF FORGING IS NOT PERMISSIBLE AT ANY STAGE.
- DIALLING BANDS B1 AND B2 SHALL BE USED FOR RESETTING SHAFT AT BHEL WORKS. THESE SHALL BE DIALLED WITHIN 0.05.
- INSPECTION SHALL BE DONE AS PER CUSTOMER APPROVED QA PLAN QA/HG/509
- 6-COPIES OF TEST CERTIFICATES TO BE SUPPLIED, P.F. NO. OF FORGING AND CAST NO. OF BILLET TO BE QUOTED ON CORRESPONDING COPIES OF TEST CERTIFICATES.
- INSPECTION SHALL BE CARRIED OUT IN THE PRESENCE OF BHEL/THIRD PARTY/CUSTOMER.

THE INFORMATION ON THIS DOCUMENT IS THE PROPERTY OF BHARAT HEAVY ELECTRICALS LIMITED. IT MUST NOT BE USED DIRECTLY OR INDIRECTLY IN ANY WAY DETRIMENTAL TO THE INTEREST OF THE COMPANY.

INVENTORY NO. SIGN AND DATE REF. DRG. NO.

59	64	65	75	78	79	25	27	29	58	59	60	77	29	31	34	45	55	56	57	58	65	72																						
VAR00	REMARKS	VAR. NO.	ITEM NO.	DESCRIPTION	STD	DRAWING NO.	MATL. CODE	MATL. SPCN.	UNIT WT.	QTY.	ZONE	9906	HG10035	NA	NA	9906	NA	NA	NA	NA	NA	NA																						
28 → CARD TYPE-3												28 → CARD TYPE-1												28 → CARD TYPE-2																				
ADDITIONAL INFORMATION W.O. NO. 30328-A-23154												STATUS OF DRAWING U												DISTRIBUTION OF PRINTS																				
mRikn dk i-dkj ;k xk-gd@ifj;kstuk dk uke TYPE OF PRODUCT OR NAME OF CUSTOMER/PROJECT												HGT-426/195-12D TANGEDCO/ KODAYAR (RMU)												<table border="1"> <tr> <td>CUK;k DRN.</td> <td>LU</td> <td>08.06.22</td> </tr> <tr> <td>Wkpk CRD.</td> <td>NS</td> <td>08.06.22</td> </tr> <tr> <td>Wgkksfr APPD.</td> <td>RG</td> <td>08.06.22</td> </tr> </table>												CUK;k DRN.	LU	08.06.22	Wkpk CRD.	NS	08.06.22	Wgkksfr APPD.	RG	08.06.22
CUK;k DRN.	LU	08.06.22																																										
Wkpk CRD.	NS	08.06.22																																										
Wgkksfr APPD.	RG	08.06.22																																										
foHAKx DEPT. HGE. UNTO. DIMS. GR. CODE 403												wu_Vky_uki dh Js.kh 3250001404												<table border="1"> <tr> <td>wuqjkr SCALE</td> <td>1:12</td> </tr> <tr> <td>HAKj fd_32k</td> <td>9906</td> </tr> </table>												wuqjkr SCALE	1:12	HAKj fd_32k	9906					
wuqjkr SCALE	1:12																																											
HAKj fd_32k	9906																																											
'Ah"AZ@BLE												M&kbox d-@DRAWING NO.												en d-@ITEM NO.																				
BOTTOM SHAFT FORGING												2 254 01 20702												00																				
=B d-@SHT. NO. 01												=Bksoa dh la;@. OF SHT. 01																																

1

THE INFORMATION ON THIS DOCUMENT IS THE PROPERTY OF BHARAT HEAVY ELECTRICALS LIMITED IT MUST NOT BE USED DIRECTLY OR INDIRECTLY IN ANY WAY DETRIMENTAL TO THE INTEREST OF THE COMPANY

DRG. NO. 3 254 01 20701

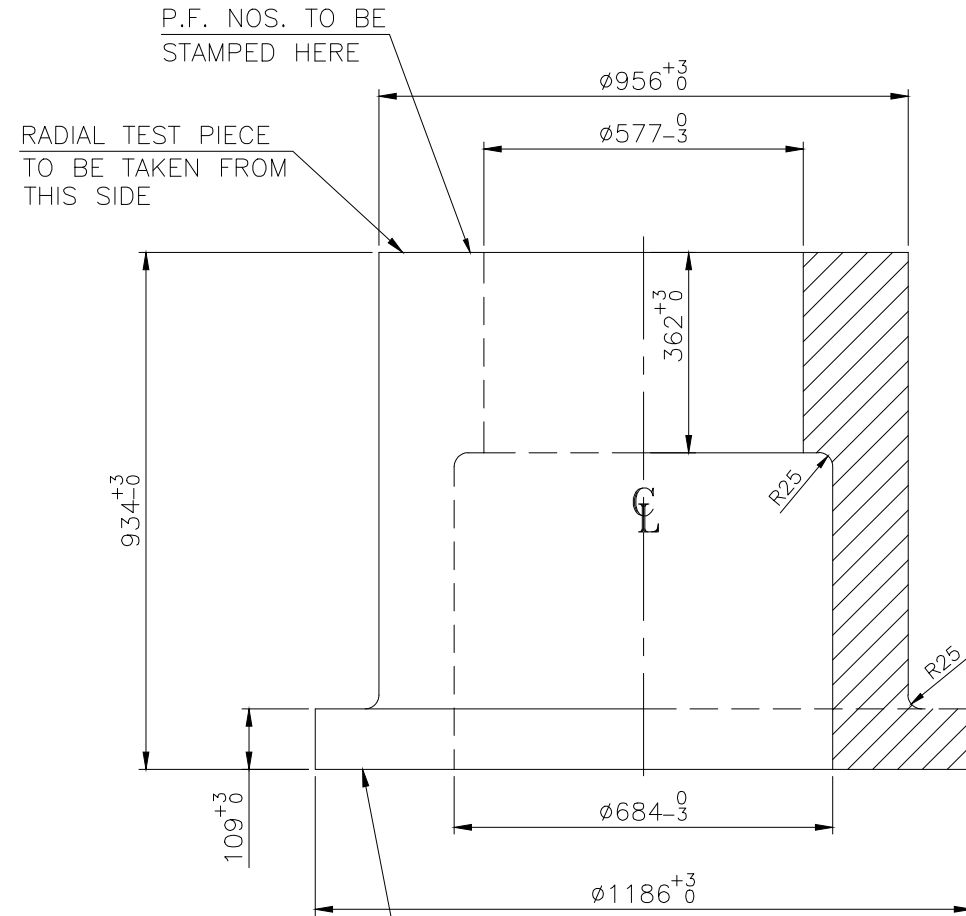

**TECHNICAL REQUIREMENTS:-**

- P.F. NOS. TO BE STAMPED AT PLACE SHOWN IN DRAWING AND RESTAMPED JUST AFTER MACHINING.  
UNIT NO. P.F. NO.  
1. 311570
- SURFACE FINISH OF MACHINED SURFACES SHALL BE 3.2 MICRONS OR BETTER ALL OVER UNLESS OTHERWISE STATED.
- ALL FACES SHOULD BE PARALLEL AND SQUARE TO THE AXIS.
- FORGING TO BE PAINTED WITH ANTI RUST PAINT INCLUDING BORE TO BP0690084.
- 6 COPIES OF TEST CERTIFICATES TO BE SUPPLIED. P.F. NO. OF FORGINGS AND CAST NO. OF BILLET TO BE QUOTED ON CORRESPONDING COPIES OF TEST CERTIFICATES.
- WELD REPAIR & COLD WORKING OF FORGING IS NOT PERMISSIBLE AT ANY STAGE.
- REFER CUSTOMER APPROVED QA PLAN FOR INSPECTION REQUIREMENT.
- INSPECTION SHALL BE CARRIED OUT IN THE PRESENCE OF BHEL/THIRD PARTY/CUSTOMER.

1

INVENTORY NO.	SIGN. & DATE	REF. DRG. NO.	28 → CARD TYPE-3		28 → CARD TYPE-1		28 → CARD TYPE-2																			
			59	64	65	75	78	79	25	27	29	58	59	60	77	29	31	34	45	54	65	58	72			
			VAR00	REMARKS	VAR. NO.	ITEM NO.	DESCRIPTION	STD	DRAWING NO.	IT.ND.	MATL. CODE	C	UNIT	QTY.	GS	ZONE										
			001 THRUST COLLAR FORGING		HG10035		3206																			
			ADDITIONAL INFORMATION W.O. NO. 30328-A-23154		mRikn dk i-dkj;k xk-gd@ifj;kstuk dk uke TYPE OF PRODUCT OR NAME OF CUSTOMER/PROJECT		HGT-426/195-12D TANGEDCO/ KODAYAR (RMU)																			
			STATUS OF DRAWING U		HAKjr gsob bysfDV&dYl fyfeVsM HAKsiky BHARAT HEAVY ELECTRICALS LTD. BHOPAL		CUK;k LU LU		NAME gLrk_@SIGN		DATE		osfj_													
			DISTRIBUTION OF PRINTS		iWpk CKD. NS		RG		08.06.22		08.06.22		08.06.22		NA											
			REV.	DATE	ALTERED	REV.	DATE	ALTERED	foHAKx DEPT. HGE.	vu_Vky_uki dh Js.kh UNTOL. DIMS. GR.	vuqikr SCALE	HAK( fd_ )z WEIGHT (K.G.)	kvl_ M&kbox dk lanHAZ REF. TO ASSY. DRG.	en d_ ITEM NO.	en la[;k NO. OF ITEM											
					CHECKED			CHECKED	dkSM CODE 403	32500001404	1:12.5	3206	NA	NA	001											
					APPROVED			APPROVED	'Ah"AZ@E		THRUST COLLAR (FORGING)		M&kbox dDRAWING NO.		3 254 01 20701		00									
													i="B d- SHT. NO. 01		i="Bksa dh la[;k NO. OF SHT. 01											

DECLARATION BY VENDOR

We declare that the following family firms or sister concern affiliates / subsidiary firms are participating in the tender No E.....:

- 1.0 .....
- 2.0 .....
- 3.0 .....
- .....

I ....., hereby declare on behalf of M/s ..... and the family firms or sister concern affiliates / subsidiary firms listed above that we are not indulging in cartel formation for Enquiry No E.....

(.....)

For M/s .....

(Seal & Sign)

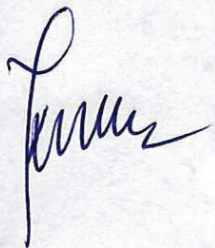

## Company Letter head

Date: {insert date}

To,  
 Bharat Heavy Electricals Limited  
 Piplani  
 Bhopal-462023  
 Madhya Pradesh  
 India

I/We hereby certify (for the period from \*\_\_\_\_\_ to \_\_\_\_\_) that,

1. {Name of company} (Vendor Code with BHEL) is a company incorporated on {insert date}{insert date} under the {Law of the Country}
2. It is a tax resident as per the Tax Laws of {country}.
3. The Company has its permanent establishment in India as defined in Article 5 of the Agreement for Avoidance of Double Taxation between India and \_\_\_\_\_ ("the tax treaty" for short).  
**And/or**
4. the Company has a fixed place of business in India through which its business is wholly or partly conducted as stipulated in Article 5 of the tax treaty  
**And/or**
5. the Company has agent(not of independent status) in India as stipulated in Article 5 of the tax treaty  
**And/or**
6. The company has business connection in India as per Sec 9(1) of the Indian Income Tax Act 1961 through which its business is carried on in India.

**But as far as our business dealing with your organization is concerned we are not using this permanent establishment and business connections and we are dealing directly from our office situated in \_\_\_\_\_.**

I hereby declare that the above information is correct and complete to the best of my knowledge and belief. Further I undertake to promptly inform the Company (i.e. BHEL) in writing should there be any change in the facts given above.

I/We, my/our legal heirs, executors and administrators hereby indemnify and keep indemnified the Company (i.e. BHEL) for any loss (including but not limited to tax, interest and penalty) suffered by as a result of the Company (i.e. BHEL) relying on this declaration and/or my delay/default in confirming the change, if any, in the facts mentioned above. This obligation shall be in force at all times.

This certificate is being issued to the Customer / Client / Payee to enable them to decide upon the With Holding Tax applicable on transaction with our company.

If there is any change in the above facts the same would be intimated to you.

For & On behalf of

{Insert name of the company}

Authorized Signatory with Seal

\*The period can be decided by the issuer & no fresh certificate will be asked for releasing payment within this period.

## Company Letter head

Date: {insert date}

To,  
Bharat Heavy Electricals Limited  
Piplani  
Bhopal-462023  
Madhya Pradesh  
India

I/We hereby certify (for the period from\* \_\_\_\_\_ to \_\_\_\_\_) that,

1. {Name of company} (Vendor Code with BHEL) is a company incorporated on {insert date}{insert date} under the {Law of the Country}
2. It is a tax resident as per the Tax Laws of {country}.
3. The Company does not have and is not likely to have a permanent establishment in India as defined in Article 5 of the Agreement for Avoidance of Double Taxation between India and \_\_\_\_\_ ("the tax treaty" for short).
4. In this regard, it is further confirmed that:
  - the Company does not have or is not likely to have a fixed place of business in India through which its business is wholly or partly conducted as stipulated in Article 5 of the tax treaty
  - the Company does not have or is not likely to have any dependent agent in India as stipulated in Article 5 of the tax treaty
5. The company does not have any business connection in India as per Sec 9(1) of the Indian Income Tax Act 1961 through which business is carried on in India.

I hereby declare that the above information is correct and complete to the best of my knowledge and belief. Further I undertake to promptly inform the Company (i.e. BHEL) in writing should there be any change in the facts given above.

I/We, my/our legal heirs, executors and administrators hereby indemnify and keep indemnified the Company (i.e. BHEL) for any loss (including but not limited to tax, interest and penalty) suffered by as a result of the Company (i.e. BHEL) relying on this declaration and/or my delay/default in confirming the change, if any, in the facts mentioned above. This obligation shall be in force at all times.

This certificate is being issued to the Customer / Client / Payee to enable them to decide upon the With Holding Tax applicable on transaction with our company.

If there is any change in the above facts the same would be intimated to you.

For& On behalf of

{Insert name of the company}

Authorized Signatory with Seal

\*The period can be decided by the issuer & no fresh certificate will be asked for releasing payment within this period.

**PROCEDURE FOR INCORPORATION OF MODEL CONCILIATION CLAUSE  
FOR CONDUCTING CONCILIATION PROCEEDINGS UNDER BHEL  
CONCILIATION SCHEME, 2018**

1. The following Model Conciliation Clause along with its Annexure & Appendices thereto is to be incorporated in the General Conditions of Contract of the Unit/Division/Region/Business Group for vendors/supplier/sub-contractors or as the case may be in the Contracts/MOUs with Customers Collaborators, Consortium Partners etc., by all the Units/Divisions/Regions/Business Group.
2. For existing Contracts where specific clause for Conciliation is not provided, this Scheme may also be made applicable with the approval of the concerned Head of Unit/Division/Region/Business Group, subject to the agreement of the other party in terms of Para A4 or A5 of the BHEL Conciliation Scheme, 2018 as the case may be.
3. Accordingly, for existing Contracts/MoUs, the Model Conciliation Clause along with its Annexure & Appendices thereto shall be made available to the vendors/supplier/sub-contractors or as the case may be in the Contracts/MOUs with Customers Collaborators, Consortium Partners etc., for their consent. Upon consent being received, the Contract/MoU shall be amended as per Paras A4 or A5 of the BHEL Conciliation Scheme, 2018 accordingly and steps be taken for initiation of Conciliation for settlement of disputes in terms of the BHEL Conciliation Scheme, 2018.

**MODEL CONCILIATION CLAUSE FOR CONDUCTING CONCILIATION  
PROCEEDINGS UNDER THE BHEL CONCILIATION SCHEME, 2018**

The Parties agree that if at any time (whether before, during or after the arbitral or judicial proceedings), any Disputes (which term shall mean and include any dispute, difference, question or disagreement arising in connection with construction, meaning, operation, effect, interpretation or breach of the agreement, contract or the Memorandum of Understanding (delete whichever is inapplicable), which the Parties are unable to settle mutually), arise inter-se the Parties, the same may, be referred by either party to Conciliation to be conducted through Independent Experts Committee to be appointed by competent authority of BHEL from the BHEL Panel of Conciliators.

Notes:

1. No serving or a retired employee of BHEL/Administrative Ministry of BHEL shall be included in the BHEL Panel of Conciliators.
2. Any other person(s) can be appointed as Conciliator(s) who is/are mutually agreeable to both the parties from outside the BHEL Panel of Conciliators.

The proceedings of Conciliation shall broadly be governed by Part-III of the Arbitration and Conciliation Act 1996 or any statutory modification thereof and as provided in Annexure----- to this GCC.

The Annexure ----- together with it's appendices will be treated as if the same is part and parcel hereof and shall be as effectual as if set out herein in these GCC.

**ANNEXURE TO MODEL CONCILIATION CLAUSE FOR CONDUCT OF  
CONCILIATION UNDER THE BHEL CONCILIATION SCHEME, 2018**

**BRIEF PROCEDURE FOR CONDUCT OF CONCILIATION PROCEEDINGS**

1. The proceedings of Conciliation shall broadly be governed by Part-III of the Arbitration and Conciliation Act 1996 or any statutory modification thereof and as provided herein:
2. The party desirous of resorting to Conciliation shall send an invitation/notice in writing to the other party to conciliate specifying all points of Disputes with details of the amount claimed. The party concerned shall not raise any new issue thereafter. Parties shall also not claim any interest on claims/counter-claims from the date of notice invoking Conciliation till the conclusion of the Conciliation proceedings.
3. The party receiving the invitation/notice for Conciliation shall within 30 days of receipt of the notice of Conciliation intimate its consent for Conciliation along with its counter-claims, if any.
4. The Conciliation in a matter involving claim or counter-claim (whichever is higher) up to Rs 5 crores shall be carried out by sole Conciliator nominated by BHEL while in a matter involving claim or counter-claim (whichever is higher) of more than Rs 5 crores Conciliation shall be carried out by 3 Conciliators nominated by BHEL.
5. The Parties shall be represented by only their duly authorized in-house executives/officers and neither Party shall be represented by a Lawyer.
6. The first meeting of the IEC shall be convened by the IEC by sending appropriate communication/notice to both the parties as soon as possible but not later than 30 days from the date of his/their appointment. The hearings in the Conciliation proceeding shall ordinarily be concluded within two (2) months and, in exceptional cases where parties have expressed willingness to settle the matter or there exists possibility of settlement in the matter, the proceedings may be extended by the IEC by a maximum of further 2 months with the consent of the Parties subject to cogent reasons being recorded in writing.
7. The IEC shall thereafter formulate recommendations for settlement of the Disputes supported by reasons at the earliest but in any case within

15 days from the date of conclusion of the last hearing. The recommendations so formulated along with the reasons shall be furnished by the IEC to both the Parties at the earliest but in any case within 1 month from the date of conclusion of the last hearing.

8. Response/modifications/suggestions of the Parties on the recommendations of the IEC are to be submitted to the IEC within time limit stipulated by the IEC but not more than 15 days from the date of receipt of the recommendations from the IEC.
9. In the event, upon consideration, further review of the recommendations is considered necessary, whether by BHEL or by the other Party, then, the matter can be remitted back to the IEC with request to reconsider the same in light of the issues projected by either/both the Parties and to submit its recommendations thereon within the following 15 days from the date of remitting of the case by either of the Parties.
10. Upon the recommendations by the Parties, with or without modifications, as considered necessary, the IEC shall be called upon to draw up the Draft Settlement Agreement in terms of the recommendations.
11. When a consensus can be arrived at between the parties only in regard to any one or some of the issues referred for Conciliation the draft Settlement Agreement shall be accordingly formulated in regard to the said Issue(s), and the said Settlement Agreement, if signed, by the parties, shall be valid only for the said issues. As regards the balance issues not settled, the parties may seek to resolve them further as per terms and conditions provided in the contract.
12. In case no settlement can be reached between the parties, the IEC shall by a written declaration, pronounce that the Conciliation between the parties has failed and is accordingly terminated.
13. Unless the Conciliation proceedings are terminated in terms of para 22 (b), (c) & (d) herein below, the IEC shall forward his/its recommendations as to possible terms of settlement within one (1) month from the date of last hearing. The date of first hearing of Conciliation shall be the starting date for calculating the period of 2 months.

14. In case of 3 members IEC, 2 members of IEC present will constitute a valid quorum for IEC and meeting can take place to proceed in the matter after seeking consent from the member who is not available. If necessary, videoconferencing may be arranged for facilitating participation of the members. However, the IEC recommendations will be signed by all members. Where there is more than one (1) Conciliator, as a general rule they shall act jointly. In the event of differences between the Members of IEC, the decision/recommendations of the majority of the Members of IEC shall prevail and be construed as the recommendation of the IEC.
15. The Draft Settlement Agreement prepared by the IEC in terms of the consensus arrived at during the Conciliation proceedings between the Parties shall be given by the IEC to both the parties for putting up for approval of their respective Competent Authority.
16. Before submitting the draft settlement agreement to BHEL's Competent Authority viz. the Board Level Committee on Alternative Dispute Resolution (BLCADR) for approval, concurrence of the other party's Competent Authority to the draft settlement agreement shall be obtained by the other party and informed to BHEL within 15 days of receipt of the final draft settlement agreement by it. Upon approval by the Competent Authority, the Settlement Agreement would thereafter be signed by the authorized representatives of both the Parties and authenticated by the members of the IEC.
17. In case the Draft Settlement Agreement is rejected by the Competent Authority of BHEL or the other Party, the Conciliation proceedings would stand terminated.
18. A Settlement Agreement shall contain a statement to the effect that each of the person(s) signing thereto (i) is fully authorized by the respective Party(ies) he/she represents, (ii) has fully understood the contents of the same and (iii) is signing on the same out of complete freewill and consent, without any pressure, undue influence.
19. The Settlement Agreement shall thereafter have the same legal status and effect as an arbitration award on agreed terms on the substance of the dispute rendered by an arbitral tribunal passed under section 30 of the Arbitration and Conciliation Act, 1996.
20. Acceptance of the Draft Settlement Agreement/recommendations of the Conciliator and/or signing of the Settlement Agreement by BHEL shall

however, be subject to withdrawal/closure of any arbitral and/or judicial proceedings initiated by the concerned Party in regard to such settled issues.

21. Unless otherwise provided for in the agreement, contract or the Memorandum of Understanding, as the case may be, in the event of likelihood of prolonged absence of the Conciliator or any member of IEC, for any reason/incapacity, the Competent Authority/Head of Unit/Division/Region/Business Group of BHEL may substitute the Conciliator or such member at any stage of the proceedings. Upon appointment of the substitute Conciliator(s), such reconstituted IEC may, with the consent of the Parties, proceed with further Conciliation into the matter either de-novo or from the stage already reached by the previous IEC before the substitution.
22. The proceedings of Conciliation under this Scheme may be terminated as follows:
- a. On the date of signing of the Settlement agreement by the Parties; or,
  - b. By a written declaration of the IEC, after consultation with the parties, to the effect that further efforts at conciliation are no longer justified, on the date of the declaration; or,
  - c. By a written declaration of the Parties addressed to the IEC to the effect that the Conciliation proceedings are terminated, on the date of the declaration; or,
  - d. By a written declaration of a Party to the other Party and the IEC, if appointed, to the effect that the Conciliation proceedings are terminated, on the date of the declaration.
  - e. On rejection of the Draft Settlement Agreement by the Competent Authority of BHEL or the other Party.
23. The Conciliator(s) shall be entitled to following fees and facilities:

<b>Sl No</b>	<b>Particulars</b>	<b>Amount</b>
1	Sitting fees	Each Member shall be paid a Lump Sum fee of Rs 75,000/- for the whole case payable in terms of paragraph No. 27 herein below.
2	Towards drafting of settlement agreement	In cases involving claim and/or counter-claim of up to Rs 5crores. Rs 50,000/- (Sole Conciliator)

Sl No	Particulars	Amount
		<p>In cases involving claim and/or counter-claim of exceeding Rs 5 crores but less than Rs 10 crores. Rs 75,000 (per Conciliator)</p> <p>In cases involving claim and/or counter-claim of more than Rs 10 crores. Rs 1,00,000/- (per Conciliator)</p> <p>Note: The aforesaid fees for the drafting of the Settlement Agreement shall be paid on Signing of the Settlement Agreement after approval of the Competent Authority or Rejection of the proposed Settlement Agreement by the Competent Authority of BHEL.</p>
3	Secretarial expenses	<p>Rs 10,000/- (one time) for the whole case for Conciliation by a Sole Member IEC.</p> <p>Where Conciliation is by multi member Conciliators –Rs 30,000/- (one time)- to be paid to the IEC</p>
4	<p>Travel and transportation and stay at outstation</p> <p>i) Retired Senior Officials of other Public Sector Undertakings (pay scale wise equivalent to or more than E-8 level of BHEL)</p>	<p>As per entitlement of the equivalent officer (pay scale wise) in BHEL.</p>
	Others	<p>As per the extant entitlement of whole time Functional Directors in BHEL.</p>

Sl No	Particulars	Amount
		Ordinarily, the IEC Member(s) would be entitled to travel by air Economy Class.
5	Venue for meeting	Unless otherwise agreed in the agreement, contract or the Memorandum of Understanding, as the case may be, the venue/seat of proceedings shall be the location of the concerned Unit / Division / Region / Business Group of BHEL. Without prejudice to the seat/venue of the Conciliation being at the location of concerned BHEL Unit / Division / Region / Business Group, the IEC after consulting the Parties may decide to hold the proceedings at any other place/venue to facilitate the proceedings. Unless, Parties agree to conduct Conciliation at BHEL premises, the venue is to be arranged by either Party alternately.

24. The parties will bear their own costs including cost of presenting their cases/evidence/witness(es)/expert(s) on their behalf. The parties agree to rely upon documentary evidence in support of their claims and not to bring any oral evidence in IEC proceedings.
25. If any witness(es) or expert(s) is/are, with the consent of the parties, called upon to appear at the instance of the IEC in connection with the matter, then, the costs towards such witness(es)/expert(s) shall be determined by the IEC with the consent of the Parties and the cost so determined shall be borne equally by the Parties.
26. The other expenditures/costs in connection with the Conciliation proceedings as well as the IEC's fees and expenses shall be shared by the Parties equally.
27. Out of the lump sum fees of Rs 75,000/- for Sitting Fees, 50% shall be payable after the first meeting of the IEC and the remaining 50% of the Sitting Fees shall be payable only after termination of the conciliation proceedings in terms of para 22 hereinabove.

28. The travelling, transportation and stay at outstation shall be arranged by concerned Unit as per entitlements as per Serial No. 3 of the Table at para 23 above, and in case such arrangements are not made by the BHEL Unit, the same shall be reimbursed to the IEC on actuals limited to their entitlement as per Serial No. 4 of the Table at Para 23 above against supporting documents. The IEC Member(s) shall submit necessary invoice for claiming the fees/reimbursements.
29. The Parties shall keep confidential all matters relating to the conciliation proceedings. Confidentiality shall extend also to the settlement agreement, except where its disclosure is necessary for purposes of its implementation and enforcement or as required by or under a law or as per directions of a Court/Governmental authority/regulatory body, as the case may be.
30. The Parties shall not rely upon or introduce as evidence in any further arbitral or judicial proceedings, whether or not such proceedings relate to the Disputes that is the subject of the Conciliation proceedings:
  - a. Views expressed or suggestions made by the other party in respect of a possible settlement of the Disputes;
  - b. admissions made by the other party in the course of the Conciliator proceedings;
  - c. proposals made by the Conciliator;
  - d. The fact that the other Party had indicated his willingness to accept a proposal for settlement made by the Conciliator.
31. The Parties shall not present the Conciliator(s) as witness in any Alternative Dispute Resolution or Judicial proceedings in respect of a Disputes that is/was the subject of that particular Conciliation proceeding.
32. None of the Conciliators shall act as an arbitrator or as a representative or counsel of a Party in any arbitral or judicial proceeding in respect of a Disputes that is/was the subject of that particular Conciliation proceeding.
33. The Parties shall not initiate, during the Conciliation proceedings, any arbitral or judicial proceedings in respect of a Disputes that is the subject matter of the Conciliation proceedings except that a Party may initiate arbitral or judicial proceedings where, in his opinion, such proceedings are necessary for preserving his rights including for preventing expiry of period of limitation. Unless terminated as per the provisions of this Scheme, the Conciliation proceedings shall continue

notwithstanding the commencement of the arbitral or judicial proceedings and the arbitral or judicial proceedings shall be primarily for the purpose of preserving rights including preventing expiry of period of limitation.

34. The official language of Conciliation proceedings under this Scheme shall be English unless the Parties agree to some other language.

**Format 2 to BHEL Conciliation Scheme, 2018****FORMAT FOR SEEKING CONSENT FOR REFERRING THE DISPUTES TO  
CONCILIATION THROUGH IEC**

To,

M/s. (Stakeholder's name)

**Sub: Resolution of the Disputes through conciliation by Independent  
Expert Committee (IEC).**

Ref: Contract No/MoU/Agreement/LOI/LOA& date \_\_\_\_\_.

Sir,

With reference to above referred Contract/MoU/Agreement/LOI/LOA, you have raised certain Disputes/claims. Vide your letter dated\_\_\_\_ you have requested BHEL to refer the Disputes/claims to IEC for Conciliation.

We are enclosing herewith Format (3) for giving consent and the terms and conditions of BHEL Conciliation Scheme, 2018 governing conciliation through IEC. You are requested to give your unconditional consent to the said terms and conditions of the Scheme by returning the same duly sealed and signed on each page. On receipt of your consent, matter will be put to the Competent Authority for consideration and decision.

Please note that BHEL has also certain claims against you (if applicable). BHEL reserves its right to agree or not to agree conciliation of the said disputes through BHEL and this letter is being issued without prejudice to BHEL's rights and contentions available under the contract and law.

Yours faithfully,

**Representative of BHEL**

**Format 3 to BHEL Conciliation Scheme, 2018**  
**FORMAT FOR GIVING CONSENT BY**  
**CONTRACTOR/VENDOR/CUSTOMER/COLLABORATOR/CONSORTIUM PARTNERS FOR REFERRING THE DISPUTES TO CONCILIATION THROUGH IEC**

To,

BHEL

.....

**Sub: Resolution of Disputes through Conciliation by Independent Expert Committee (IEC).**

Ref: Contract/MoU/Agreement/LOI/LOA No & date\_\_\_\_

With reference to above referred contract, our following bills/invoices/claims submitted to BHEL are still unpaid giving rise to Disputes:

SL. no.	Claim Description	Bill submitted to BHEL (no. and date)	Amount of the bill/claim	Amount received from BHEL	Outstanding Amount

Accordingly we request you to kindly refer the Disputes in respect of above claims to IEC for Conciliation.

We hereby agree and give our unconditional consent to the terms and conditions of BHEL Conciliation Scheme, 2018 governing conciliation through IEC. We have signed the same on each page and enclosed it for your consideration.

Yours faithfully,

**(Signature with stamp)**

**Authorized Representative of Contractor**

**Name, with designation**

**Date**

**Format 5 to BHEL Conciliation Scheme, 2018**  
**STATEMENT OF CLAIMS/COUNTER CLAIMS TO BE SUBMITTED TO**  
**THE IEC BY BOTH THE PARTIES**

1. Chronology of the Disputes
2. Brief of the Contract/MoU/Agreement/LOI/LOA
3. Brief history of the Disputes:
4. Issues:
5. Details of Claim(s)/Counter Claim(s):

SI. No.	Description of claim(s)/Counter Claim	Amount (in INR)Or currency applicable in the contract	Relevant contract clause

6. Basis/Ground of claim(s)/counter claim(s) (along with relevant clause of contract)

**Note**– *The Statement of Claims/Counter Claims may ideally be restricted to maximum limit of 20 pages. Relevant documents may be compiled and submitted along with the statement of Claims/Counter Claims. The statement of Claims/Counter Claims is to be submitted to all IEC members and to the other party by post as well as by email.*



BP 200102A

## GENERAL TERMS AND CONDITIONS OF ENQUIRY

Sl.No.	Description
1	<b>General:</b>
A	These General terms & conditions (GTC) shall apply to all enquiries, notice inviting tenders, request for quotations concerning the supply of goods and / or rendering of services to Bharat Heavy Electricals Ltd., Bhopal (hereinafter referred to as BHEL or the Purchaser) or its Projects / Customers. Special / supplementary enquiry conditions, if any, will override the conditions in this annexure.
2	<b>General Instructions - Common for Indigenous &amp; Foreign enquiries</b>
A	<b>Through E- procurement</b>
A1	<ol style="list-style-type: none"><li>Offer shall be submitted by the bidders in single/two parts as called in Tender enquiry. Bid Part - I Technical cum Commercial bid Bid Part - II Price bid</li><li>Suppliers shall quote <b>price</b> on BHEL authorised third party service provider <b>e-procurement site</b>. Any deviation from the price format shall be clearly brought out in the offer Bid Part I.</li></ol> <p>The offer shall be uploaded on BHEL e-procurement site using Class III digital signature. <b>All documents to be uploaded are necessarily to be signed and stamped.</b> The quotation should be uploaded on the site before due date and time. Part-I of the bid shall contain complete item-wise scope of supply as offered vis-à-vis the scope of supply as per enquiry, all commercial terms and conditions etc. It is expected that bidders shall meet all our technical and commercial requirements and shall not deviate from them.</p>
B	<b>Through tender room</b>
B1	Sealed bids are invited for scope of Supply / Services as detailed in the enquiry. Bid should be free from correction, overwriting, using of corrective fluid etc. Any interlineation, cutting, overwriting shall be valid only if they are attested under full signature(s) of persons signing the bid else shall be liable for rejection. All overwriting/ cutting etc. will be numbered by bid opening officials and announced during bid opening. The bid should be submitted in English or Hindi language. Relevant enclosures, supporting documents, catalogue, samples, if any, as required as per Notice Inviting Tender (NIT) conditions shall be sent along with technical offer. Rate should be quoted in the units asked for in the enquiry.
B2	Bids shall be submitted in a Sealed cover with Enquiry No., Due date and Bidder's name indicated on the cover. In case of Two Part Bid, technical bid containing technical offer, this GTC duly filled-in & signed; and <b>un-priced copy</b> of the Price Bid should be kept in one envelope. Price Bid containing only the price (as called for in the price format where required) should be kept in a separate envelope. Both envelopes indicating Part —I or Part-II as the case may be to be put in a bigger envelope, which should be addressed to in charge, Tender Room, Bharat Heavy Electricals Ltd. 2 <sup>nd</sup> Floor, Jawahar Bhavan, Piplani, Bhopal 462022. Enquiry No., due date and bidder's name must be mentioned on all envelopes. Offer must reach tender room of BHEL Bhopal latest by 11.00 am IST on the enquiry due date. Bids submitted as single part bid against two – part bid, shall be rejected unless the offer is techno-commercially acceptable without seeking any clarification.
B3	Offer received after 11.00 AM IST of the due date will be termed as "Late" and shall not be considered. However, late offer received against single tender enquiry may be considered.
B4	Bidder can also submit offer through email, if called for in the enquiry, at the email address indicated in the enquiry. Such email offers shall be sent only on designated email-id to reach before 11.00 am IST on the tender due date. BHEL will not be responsible for incomplete offers and the ones delivered late through e-mail.
C	<b>Through tender room or EProcurement</b>
C1	Commercial Conditions quoted by the bidder in any place including as stated in bidder's 'General Terms and Conditions' if any, shall not be binding on the Purchaser and the conditions contained in this annexure, including special conditions, if any, for this enquiry shall only prevail.
C2	Rate should be quoted in the units asked for in the enquiry. The rates should be quoted both in figures and words. In case of discrepancy in figures and words, the rates quoted in words shall be considered.
C3	The goods offered shall conform to BHEL specifications and / or National/International standards as mentioned in the Enquiry and the bidder is required to confirm his unconditional acceptance to the same. Bidders, seeking deviations from the specifications and any other conditions, may indicate the same clearly on a separate sheet indicating Sl. No. of the item, with reasons for such deviations. BHEL reserves the right to reject the offer with deviations or load the deviations suitably for evaluation.
C4	Offers shall be submitted directly by bidder or his authorized agent only. Unsolicited offers shall be summarily rejected.



BP 200102A

**GENERAL TERMS AND CONDITIONS OF ENQUIRY**

C5	Bid in single part or techno-commercial bid in <b>two-part</b> system (as the case may be) will be opened on the due date. In case of two part bid, price bids of techno-commercially accepted bidder(s) only shall be opened on the assigned date, for which separate intimation will be sent to the accepted bidders.
C6	The bidder whose bid is technically not accepted will be informed & EMD wherever submitted shall be returned along with his price bid within <i>30 days</i> of contract finalization date. No interest will be payable on EMD amount. EMD shall however be forfeited in the event of bidder opting out after submission of the bid.
C7	<ol style="list-style-type: none"> <li>Any discount / revised offer submitted by a bidder on its own shall be considered, provided it is received on or before the due date and time of offer submission (Part-I). Conditional discounts shall not be considered for evaluation of tenders.</li> <li>Unsolicited discounts / revised offers given after Part-I bid opening shall not be accepted. No change in price will be permitted within the validity period of offer.</li> <li>In case of changes in scope and / or technical specification and / or commercial terms &amp; conditions, having price implication, techno-commercially acceptable bidders shall be asked by BHEL to submit the impact of such changes on their price bids. In case a bidder opts to submit revised price bid instead of impact called for, then latest price bid shall prevail. However in both situations, original price bid will be necessarily opened.</li> </ol>
C8	The bidders will submit Integrity Pact, duly signed by its authorized signatory, where called for in the enquiry.
C9	Wherever the enquiry is issued to unregistered bidder, the bidder shall visit ' <a href="http://www.bhel.com">www.bhel.com</a> ' for submitting the online Supplier Registration Application. Price bids of such bidders, will be opened only on techno-commercial acceptance of bid & after supplier registration.
C10	BHEL expects that the bidder responds to the enquiry. Regret letter, with valid reasons for not participating in the tender will be submitted where the bidder is unable to submit offer. Repeated lack of response on the part of bidder may lead to his deletion from BHEL's approved bidder list. Refer guidelines for suspension of Business Dealings with Suppliers/Contractors available on <a href="https://www.bhel.com/sites/default/files/suspension_guidelines_abridged.pdf">https://www.bhel.com/sites/default/files/suspension_guidelines_abridged.pdf</a>
C11	In case of open tenders (i.e. those published in website) all corrigenda, addenda, amendments, time extensions, clarifications etc. to the tender will be hosted on BHEL website. ( <a href="http://www.bhel.com">www.bhel.com</a> ) only. Bidders responding to these tender should regularly visit website(s) to keep themselves updated.
C12	In the course of evaluation, if more than one bidder happens to occupy L-1 status effective L-1 will be decided by soliciting discounts from the respective L-1 bidders in sealed envelope and will be open in tender room. In case more than one bidder happens to occupy the L-1 status even after soliciting discounts, the L-1 bidder shall be decided by a toss/ draw of lots, in presence of the respective L-1 bidders or their representatives. Ranking will be done accordingly. BHEL's decision in such situations shall be final and binding.
C13	The Purchaser can consider awarding tendered quantities among more than one bidder (after acceptance of L1 price by the other bidders) in the manner and proportion disclosed in the tender conditions. Purchaser can also consider awarding of part of the tendered quantity to other than L-1 bidder at <b>L1</b> counter offered rates, if the quantity offered by the L-1 bidder is less than the quantity tendered for.
C14	The bidder shall submit price bid strictly in the price format, wherever provided for, in the enquiry. Any attempt on the part of the bidder to alter the contents of the price bid format in any manner, which in the opinion of BHEL can vitiate the tendering process, will lead to rejection of the bid, <b>besides BHEL taking appropriate punitive action as deemed fit.</b> Refer Guidelines for suspension of Business Dealings with Suppliers/Contractors available on <a href="https://www.bhel.com/sites/default/files/suspension_guidelines_abridged.pdf">https://www.bhel.com/sites/default/files/suspension_guidelines_abridged.pdf</a>
D	BHEL shall be resorting to Reverse Auction (RA) (Guidelines as available on <a href="http://www.bhel.com">www.bhel.com</a> ). If tender specific conditions call for reverse auction, RA shall be conducted among the techno-commercially qualified bidders. Price bids of all techno-commercially qualified bidders shall be opened and same shall be considered for RA. In case any bidder(s) do(es) not participate in online Reverse Auction, their sealed envelope price bid along with applicable loading, if any, shall be considered for ranking
3	<b>Delivery Terms</b>
A	<b>Indigenous Purchase</b>
A1	Goods shall be delivered on 'FOR Destination' basis to the named destination unless otherwise called for in the enquiry.
B	<b>Foreign Purchase — Imports</b>
B1	<ol style="list-style-type: none"> <li>Goods shall be despatched by Sea, unless stated otherwise in the enquiry or purchase order.</li> <li>Terms of Delivery for Sea shipment shall be on CFR / CIF basis with 14 days' detention free period preferably at Dry Port - ICD Mandideep (INMDD6) for FCL (Full Container Load) Cargo of GP &amp; HC Containers.</li> <li>For other cases - Other than GP &amp; HC Containers, LCL Cargo shall be delivered at Nhava Sheva (JNPT- INNSA1) &amp; Break-bulk Cargo at Mumbai (MPT - INBOM1).</li> <li>For Air consignments, the terms of delivery shall be FCA at BHEL nominated Airport. In case of CIP, delivery shall be at Mumbai ACC (INBOM4).</li> <li>Freight amount shall be indicated separately in the offer in case of CIP/CFR/CIF.</li> </ol>



BP 200102A

## GENERAL TERMS AND CONDITIONS OF ENQUIRY

	<p>6. The number of detention free days and destination charges payable to shipping line must be mentioned in your offer and also on the Bill of Lading.</p> <p>7. Offer received on FOB basis may be considered on an exceptional basis. BHEL will load freight, marine insurance &amp; shipping line port handling charges etc. to work out landed cost at Sea Port.</p> <p>8. Please visit BHEL Bhopal website <a href="https://bpl.bhel.com">https://bpl.bhel.com</a> for details of named Air ports and Sea ports. Name of the gateway port so chosen by the bidder shall be indicated by the Bidder in his offer.</p> <p>9a In case of CIP/CFR/CIF, the shipping line should be ready to move the containers to consignee's nominated CFS (Container Freight Station) yard and Indian agent of shipping line should issue Cargo Arrival Notice (CAN) 7 days in advance.</p> <p>9b In case of CFR contract, bidder to supply the material through a Certified Sea worthy vessel age not more than <b>15</b> years.</p> <p>9c The invoices being issued by shipping lines must be in the name of BHEL. Otherwise, BHEL will recover loss of Input Credit on GST from the vendor.</p> <p>9d While booking the shipment, bidder to also finalize destination charges and the same should appear over BL or agreed tariff to be provided to BHEL before arrival of shipment. If cargo is stuffed in container, then the same should be allowed to be moved to CFS of importer's choice without any additional charges.</p> <p>9e Load port charges shall be settled by the supplier and not be passed on to BHEL in any form of destination charges.</p> <p>10. For reasons of delay in receipt of documents from suppliers or due to the same being found to be incomplete, and or faulty, the suppliers shall be responsible to reimburse all penalties, detention and demurrages / wharfages, if any paid by BHEL (for stated reasons).</p>	
B2	<p>1. For delivery of FCL (Full Container Load) cargo, the Bidder shall provide minimum <b>14 days' detention free period</b> from the date of delivery at Port of Discharge / Place of Delivery (in case of ICD). Wherever the detention free period offered is less than 14 days, the bids shall be <b>loaded</b> for the period short of 14 days' period.</p> <p>2. <u>Port Congestion charges or any additional charges claimed by the shipping line at Port of Discharge / Place of Delivery shall be to the Bidder's account.</u></p>	
4	<b>Bidder's particulars &amp; logistics information (Bidder to give details against each of the provisions)</b>	
A	Name of the bidder's executive to deal with this tender / project	
B	E-mail address of the contact person	
C	Telephone no. of the contact person	
D	Name of location from where the goods shall be offered for inspection and dispatch	
5	<b>Additional logistics information for Imports</b>	
A	Bid currency	
B	Charges applicable at discharge port up to BHEL's CFS (Container Freight Station) to be indicated in your offer and on the B/L	
C	Name of Airport in the country of dispatch for FCA delivery terms	
D	Estimated number, type & size of containers for delivery of tendered quantity (applicable where the goods are to be sent in FCL)	
E	No. of packages with cumulative gross weight and CBM volume (applicable for LCL & Break-bulk shipment)	
F	Approx. distance in km. from Bidder's works to Port of Loading	Sea port /Air port
6	<b>Delivery Schedule &amp; Completion date</b>	
A	<ul style="list-style-type: none"> <li>• Instead of writing specific date against delivery offered, bidder shall commit delivery period in number of days / weeks/ months to suit the delivery period indicated in the enquiry.</li> <li>• Commencement of delivery period shall be reckoned from the date of PO / LOI or any other agreed milestone.</li> <li>• Bidder shall deliver the goods in the manner and schedule agreed under the Purchase order.</li> <li>• Goods shall be delivered within contractual period or any extension thereof, if any, granted by the Purchaser.</li> <li>• If delivery is linked to approval of documents, time for submission of such documents to be indicated and delivery period to be indicated from approval of documents. This delivery schedule will be considered for processing delivery extension, wherever applicable.</li> <li>• BHEL reserves the right to cancel the order if material is not delivered within PO scheduled delivery.</li> </ul>	



BP 200102A

**GENERAL TERMS AND CONDITIONS OF ENQUIRY**

B	In case of foreign supplies, the date of Bill of Lading (B/L) or AWB shall be taken as actual date of delivery where freight until discharge port in India is in Seller's scope like CFR/CIF/CIP delivery terms. <b>For Ex-works/FCA/FOB or any other delivery term where freight is in buyer's scope, date of material readiness /Test certificate/ Warehouse receipt/Freight forwarder receipt may be considered as mutually agreed.</b>
C	In case of Indigenous bidders, the date of delivery at named destination in India shall be taken as contractual delivery completion date where delivery terms are FOR destination. In case of 'Ex-works' delivery terms, the date of LR / RR shall be the contractual delivery completion date.
7	<b>Transit Insurance</b>
A	Except where delivery terms are agreed on CIF basis for Imports & FOR destination basis for indigenous purchases, transit insurance will be covered by BHEL under its Open Marine Transit Insurance Policy. Bidder shall inform dispatch particulars with value of consignment to the Purchaser within 07 days of dispatch for BHEL to arrange insurance coverage in its policy. Failure on the part of bidder to inform dispatch particulars will make him liable to pay for any transit damages / losses suffered by the Purchaser.
8	<b>Force Majeure</b>
A	Notwithstanding anything contained in the contract, neither the Bidder nor the Purchaser shall be held responsible for total or partial non-execution of any of the contractual obligations, should the obligation become unreasonably onerous or impossible due to occurrence of a 'Force Majeure' which directly affects the obligations to be performed by the Purchaser or the Bidder; Such events include war, military operations of any nature, blockages, revolutions, insurrections, riots, civil commotions, insurgency, sabotage, acts of public enemy, fires, explosion, epidemics, quarantine restrictions, floods, earthquake, or acts of God, restrictions by Govt. authorities; over which the Bidder or the Purchaser has no control. The party claiming to be affected by force majeure shall notify the other party in writing without delay, within two weeks on the intervention and on the cessation of such circumstance. Extension of time sought by the Bidder along with supporting evidence and so granted by the Purchaser for the supply/ work affected, if any, shall not be construed as waiver in respect of remaining deliveries. Rescheduling of deliveries on account of force majeure conditions, if so agreed by the Purchaser, will not entail the Bidder to claim any increase in the price on whatsoever account. Notwithstanding above provisions, Purchaser shall reserve the right to cancel the order/ Contract, wholly or partly, in order to meet the overall project schedule and make alternative arrangements. If deemed necessary, Purchaser may takeover partly processed material at a mutually agreed price.
9	<b>Penalty for delayed performance.</b>
A1	Subject to force majeure conditions, penalty shall be 0.5% of the total order value per week of delay or part thereof, subject a maximum of 10% of the total order value. Total order value above shall be item wise, lot wise order value. Any deviation based on specific requirement shall be specified separately in the NIT.
A2	However, in case of Capital Machine / BOP where staggered deliveries may be applicable, the penalty will be levied on total order value.
A3	In case of any amendment / revision, the penalty shall be linked to the amended / revised PO.
A4	Any loading on penalty clause shall be to the extent to which it is not agreed to by the bidder ( at offered value)
B	If the material is not supplied within the agreed delivery period, BHEL reserves the right to cancel the order and purchase the material from alternate source(s) at the Risk and Cost of the Bidder. In such an event, it shall be obligatory on the part of bidder to make good any loss suffered by the purchaser.
C	In case the contractually agreed delivery date falls on a holiday in BHEL Bhopal, the next working day shall be taken as contractual delivery date for compliance and applicability of LD / penalty.
D	In case of any recovery for delayed performance, the applicable GST shall also be recoverable from bidders.
10	<b>Indian Agents and Agency commission</b>
A	BHEL prefers to deal directly with Foreign bidder, wherever required, for procurement of Goods. However if the Foreign Principal desires to avail services of an Indian Agent, then the Principal should ensure compliance to "regulatory guidelines" which will require submission of an agency agreement.
B	The CFR / CIF price quoted will be deemed to be inclusive of Indian Agency commission. Agency commission as disclosed by the bidder in his quoted CFR / CIF price will be paid in Indian Rupees on receipt & acceptance of Materials or it's installation at destination, as the case may be. The lower of the 'TT buying rate prevailing on the date of technical bid opening or price bid opening shall be considered for computation of Agency commission.
C	In a tender either the Indian Agent on behalf of Principal / OEM or the Principal / OEM itself can bid, but both cannot bid simultaneously for same item / product in the same Tender. In case bids are received from both the Principal / OEM and the agent, bid received from the agent will be ignored.
D	If an agent submits Bid on behalf of the Principal / OEM, the same agent shall not submit bid on behalf of another Principal / OEM in the Tender, for the same Item / Product.



BP 200102A

**GENERAL TERMS AND CONDITIONS OF ENQUIRY**

11	<b>Documentation:</b>		
A	<b>Indigenous Purchase</b>		
	<p>Bidder shall arrange to send to the consignee, Original Tax invoice (Buyer's copy and duplicate for Transporter), Commercial invoice in duplicate, consignee copy of LR &amp; 2 sets each of Packing list, Test certificate, Guarantee / Warranty certificate, O &amp; M manuals (where applicable), immediately on despatch of the goods. The distribution of such documents will be specified in the Purchase order.</p> <p>In case of labour / mixed basis jobs, material is issued free of cost. Necessary material reconciliation is to be done and Free Issue Material Statement (FIMS) is to be submitted with each bill.</p>		
B	<b>Foreign Purchase — Imports</b>		
	<p>Seller shall send <b>1</b> set of following documents, in English, within 7 days of B/L date / 1 day of AWB date by courier to the Purchaser</p> <ol style="list-style-type: none"> <li>Express / Original 'Clean on board' Bill of Lading / AWB.</li> <li>One set of Commercial Invoice, Packing list indicating container-wise Gross weight, Net weight, CBM volume, No. of packages with Dimensions of each package.</li> <li>Original Certificate of Country of Origin (COO) issued by Chamber of Commerce. COO shall be as per requisite format where duty concession is available under Preferential Trade/Comprehensive Economic Partnership/Free Trade agreement. Customs tariff heading (CTH)/ Harmonized System of Nomenclature (HSN) code of material should be mentioned on invoice and COO in all such cases.</li> <li>One set of Original Test Certificates and O&amp;M Manual where called for.</li> <li>Fumigation / Phyto-Sanitary Certificate wherever cargo is packed in wooden packing or packing of plant origin material is used.</li> <li>Supplier should additionally forward 2 sets of original documents mentioned at point nos. 1 to 5 above along with Original Bill of Lading (OBL) or AWB through any international courier service/registered airmail within three (3) days of obtaining the same directly to the following:</li> </ol> <table border="1" data-bbox="322 1037 1520 1265"> <tr> <td> AGM (M.S)  Regional Operations Division BHEL  14<sup>th</sup> Floor Centre-1  World Trade Centre, Cuffe Parade  Mumbai 400 005 INDIA  Email: <b>msseabpl@bhel.in</b> (In case of Sea freight)  <b>msair@bhel.in</b> (In case of Air freight) </td> <td> DGM (FIN- FP)  4<sup>th</sup> Floor, Administrative Bldg.  BHEL Bhopal - 462022 (India)  E-mail : <b>fin_fp.bpl@bhel.in</b> </td> </tr> </table> <p>And confirm forwarding details to AGM (CMM- FE), BHEL Bhopal at <b>mmfe.bpl@bhel.in</b></p> <ol style="list-style-type: none"> <li>In case the Seller decides to negotiate all 3 originals of B/L / AWB along with all original documents through negotiating Bank, non-negotiable documents (NNDs) consisting of copy of B/L / AWB &amp; documents mentioned at Sl. no. 11- B2 to B5 will be sent by e-mail to the Purchaser at his e-mail address given in the PO with one copy to be mailed at <b>mmfe.bpl@bhel.in</b> as well as at <b>msseabpl@bhel.in</b> (for Sea shipment) or <b>msair@bhel.in</b> (for Air shipment). Other documents, as required, will be separately indicated in the Purchase Order. Additional expenditure, if any, incurred by the Purchaser by way of detention / demurrage, resulting out of delay attributable to the Seller in providing Negotiable documents, will be recovered from the Seller.</li> </ol> <p>In case any discrepancy is raised by the Bankers / BHEL with respect to the documents submitted, vendor to facilitate clearance of goods through Delivery Order.</p> <p>Additionally, following requirements to be taken care of by the bidder during PO execution stage:</p> <ol style="list-style-type: none"> <li>IEC (<b>0588138690</b>), GSTIN (<b>23AAACB41461ZN</b>) and email ID (<b>mmfe.bpl@bhel.in</b>) of BHEL Bhopal shall be clearly mentioned on B/L or AWB.</li> <li>As per Uniform Customs Practice (UCP 600) for documentary credits (L/C), presentation period allowed is maximum 21 days after the date of shipment. However, for geographically closer ports where sea voyage time is less than 3-4 weeks, a shorter presentation period shall be agreed upon.</li> <li>In case of CAD payment terms, Supplier shall send documents to BHEL's bank within 5 days of shipment. One set of original may be sent to any one of ROD, CMM-FE and MM, copy may be marked to the others.</li> <li>For Air shipments through non-CONSOL (i.e., not through BHEL ROD's contract), Delivery Order (DO) should be given to BHEL without insisting for Bank Release Order (BRO). AWB to be drawn with BHEL Bhopal as consignee.</li> <li>It must be ensured that original shipping/commercial documents, if not provided to BHEL outside banking channel, should reach BHEL's bank at least 10 days prior to cargo arrival at port.</li> <li>Part shipment and trans-shipment to be avoided to the extent possible especially where it is not possible to split shipping &amp; commercial documents. Part shipment shall be strictly avoided for Airshipments.</li> </ol>	AGM (M.S) Regional Operations Division BHEL 14 <sup>th</sup> Floor Centre-1 World Trade Centre, Cuffe Parade Mumbai 400 005 INDIA Email: <b>msseabpl@bhel.in</b> (In case of Sea freight) <b>msair@bhel.in</b> (In case of Air freight)	DGM (FIN- FP) 4 <sup>th</sup> Floor, Administrative Bldg. BHEL Bhopal - 462022 (India) E-mail : <b>fin_fp.bpl@bhel.in</b>
AGM (M.S) Regional Operations Division BHEL 14 <sup>th</sup> Floor Centre-1 World Trade Centre, Cuffe Parade Mumbai 400 005 INDIA Email: <b>msseabpl@bhel.in</b> (In case of Sea freight) <b>msair@bhel.in</b> (In case of Air freight)	DGM (FIN- FP) 4 <sup>th</sup> Floor, Administrative Bldg. BHEL Bhopal - 462022 (India) E-mail : <b>fin_fp.bpl@bhel.in</b>		
C	<b>General</b>		
	<ol style="list-style-type: none"> <li>For Hazardous chemicals, the materials safety data sheet (MSDS) is to be submitted.</li> </ol>		



BP 200102A

**GENERAL TERMS AND CONDITIONS OF ENQUIRY**

	<p>2. All certificates as called must be sent. BHEL may test any goods supplied and their decision is final irrespective of supplier's certificates. If test certificate and guarantee certificate are not received along with the document and stipulated in these specifications, BHEL reserves the right to get the material tested and recover the expenses from the supplier without awaiting supplier's confirmation</p> <p>3. Goods shall be properly packed to avoid transit damage. Suitable markings shall be provided to identify the goods with that of the PO No. and the consignee details.</p> <p>4. Goods shall be consigned to AGM (CRX), BHEL, Piplani, Bhopal - 462022, India, unless otherwise specified in the PO.</p>
12	<b>Pricing Terms</b>
A	Prices once quoted shall remain firm within the validity or any extension thereof for placement of order, till complete execution of the order, without any escalation/increase for any reason, whatsoever, unless specifically provided for in the Enquiry & PO. In case of foreign bidders, the quoted price shall be taken as inclusive of Third Party Inspection and testing charges as called for in the NIT.
13	<b>Price Validity :</b>
A	Unless stated otherwise in the enquiry, offer shall be valid for a period of 90 days from the date of Techno- commercial (Part-I) bid opening date.
14	<b>Taxes &amp; Duties - Indigenous Purchase</b>
A	Bidder to ensure timely remittance of SGST, CGST, IGST as applicable in time as per law.
B	Bidder to ensure compliance to filing of monthly GST sales return including BHELs supplies by 10 <sup>th</sup> of next calendar month in the online GST portal wherever applicable.
C	Bidders to declare filing of timely returns and GST remittance/likely remittance /ITC adjustment along with invoice.
D	Bidder to submit invoices compliant with GST invoice Rules
E	Bidders to comply with all statutory provisions as may be applicable at the time of despatch/sale. Any additional financial liability to BHEL on account of non-compliance by bidders shall be borne by them and shall be adjusted / recovered from the bidders. BHEL reserves the right to review the existing offers / contracts for any revision in terms, which may arise due to change in any statutory provisions to ensure that the benefit accrues to BHEL.
F	Bidder to ensure TAX INVOICE submission along with consignment
G	In respect of cases where the liability to discharge GST is on BHEL under reverse charge mechanism, bidders have to ensure timely submission of invoices and delivery of material / services to BHEL, so that there is no mismatch on both activities. In case there is any additional financial liability on BHEL on account of default on the part of the bidder on submission or delivery of material / services the same shall be passed on to them.
H	In respect of free issue material by BHEL, bidders have to return the processed material within the time line as per the provisions of GST. In case of any additional tax liability on BHEL on account of non-compliance by the bidder, the additional financial implications on BHEL shall be passed on to the bidder
I	Bidders to provide the applicable HSN / SAC codes as called for in the enquiry
J	As per provisions of section 171 of the CGST Act 2017, bidders to pass on the anti-profiteering benefits accruing to them under GST regime to BHEL
K	With reference to section 51 of CGST act 2017 read with notification no 50/2018 – Central tax dated 13.09.2018; BHEL will be liable to deduct TDS under GST with effect from 01.10.2018. Deduction shall be made @ 2% (1% CGST + 1% SGST) or 2% IGST (as applicable) of the payment made or the amount credited. Bidder to generate & submit invoices as per above. The amount of TDS shall be deposited to the Government account and BHEL shall issue TDS certificate to deductees, TDS deposited in the Government account will be reflected in the electronic cash ledger of the deductee who will be able to use the same for payment of tax or any other amount. Deduction of TCS along with additional TDS will be as per prevailing Government guidelines.
15.	<b>Taxes &amp; Duties - Foreign Purchase — Imports</b>
A	The offered prices shall be inclusive of all the Taxes and duties as applicable in the country of bidder / country of dispatch for the quoted CFR / CIF price.
16	<b>Payment Terms-</b>
A	<b>Indigenous:</b> 100% payment in 90 days of receipt (45 days for MSE including Udyog Aadhar/ Udhyan registered suppliers as per relevant act in force), subject to acceptance of material and relevant documents at BHEL. In case of despatch of material to site directly, site certification for receipt of materials is required unless otherwise provided for in the PO. Any deviation from the above payment terms, if accepted (by BHEL), shall be loaded @ SBI base rate + 6% for the purpose of bid evaluation.
B	<b>Foreign:</b> 100% against irrevocable, unconfirmed LC, payable within 90 days of the Bill of Lading (B/L) date or Payment terms of CAD payable on 90 <sup>th</sup> day of B/L / AWB. In case BHEL considers any deviation in payment terms i.e. early payment based on bidder's request, then bids shall be evaluated with loading of State bank of India Base rate plus 6%, for the credit



BP 200102A

**GENERAL TERMS AND CONDITIONS OF ENQUIRY**

	<p>period short of 90 days. The LC shall be established 2 months prior to shipment date, valid for period of 90 days, unless agreed otherwise.</p> <p>Documents to be submitted as per UCP600 and should reach BHEL/ BHEL's bank at least 7 days prior to vessel arrival.</p>
C	<p>Foreign bidders to submit declaration of <b>Permanent Establishment and Business Connection (PEBC)</b> for remittances purpose. Declaration to be submitted in formats either in Annexure A or B whichever is applicable as per their transaction entered into with BHEL.</p> <p>In the absence of certificates from the bidder, withholding tax at applicable rates along with surcharge and cess will be recovered at the time of remittance to the bidder.</p>
D	<p>Foreign bidders to submit <b>Tax Residency Certificate (TRC) &amp; Form 10F</b> (for obtaining DTAA benefits) as per Annexure C in respect of services. The TRC (tax residency certificate) is to be issued by the authorities of the government of bidder's country. If the informative part of the format (other than residency) is not furnished by the authorities the same may be furnished by the bidder as a declaration.</p>
17	<b>Inspection of Goods</b>
A	<p>The Bidder shall give adequate notice, of 1 week or as mutually agreed period, in writing to the Purchaser (in case Customer inspection is involved) or BHEL appointed TPIA about the date and place at which the goods will be ready for inspection/ testing, as provided for in the contract.</p>
B	<p>Purchaser or his authorized representative shall be entitled to carry out inspection of material and workmanship/Surveillance Audit at Bidder's premises or at his sub-contractor's premises at all reasonable times during execution of contract; Such inspection, examination and testing, if made, shall not absolve the Bidder from his obligations under the contract.</p> <p>Wherever required, BHEL may carry out testing at BHEL's testing Lab and in case of any rejection during such testing, replacement / rectification, as required, will have to be done by Supplier.</p> <p>If BHEL carries out any rectification of such rejected material, such cost will be recovered from Supplier's Bills.</p> <p>In case of Customer inspection as Supplier's Works, inspection clearance to be obtained from Customer and submitted to BHEL.</p>
C	<p>BHEL's representative from unit or Corporate Quality (CQ) is authorised to carry out audits along with TPIA at bidder's works before clearing the items for despatch.</p>
D	<p>All costs related to inspections and re-inspections shall be borne by the Bidder. In case of inspection by BHEL and / or BHEL's customer, the cost of to &amp; fro passage and Boarding &amp; Lodging shall be borne by the Purchaser / Customer, unless otherwise specifically agreed. In case of foreign bidders, the cost of third party inspection, where called for, shall be deemed to be included in the quoted price. Bidder shall be responsible to provide assistance such as labour, materials, electricity, fuels, stores, apparatus, instruments at his cost, as may be required and as may be reasonably demanded to carry out such tests effectively.</p>
E	<p><b>REJECTION:</b></p> <p>If any goods are rejected, BHEL shall be at liberty to take action as per following at the risk and cost of supplier:</p> <p>a) Allow the supplier, wherever mutually agreed, to rectify the rejected goods at BHEL's works within reasonable time as fixed by BHEL.</p> <p style="text-align: center;">Or</p> <p>b) Allow the supplier to make free replacement within a specified period. Rejected goods can be lifted by the supplier thereafter.</p> <p style="text-align: center;">Or</p> <p>c) In case payment has been done, allow supplier to refund equivalent value of rejected material by NEFT / RTGS or furnish Bank Guarantee for same amount before lifting the rejected goods. Fresh replacement shall be regulated as per terms and condition of the original Purchase Order.</p> <p>In case payment has not been done, allow the supplier, wherever mutually agreed, to rectify the rejected goods at supplier's works within reasonable time as fixed by BHEL.</p> <p style="text-align: center;">Or</p> <p>d) Take alternate procurement action from elsewhere and recover the difference in total cost to BHEL including services, if any, incurred by BHEL in this regard from the supplier. The supplier shall not be entitled to any gain on repurchase.</p> <p style="text-align: center;">Or</p> <p>e) Terminate the contract either in part or in whole at the discretion of BHEL and recover the loss, if any, from the supplier.</p> <p style="text-align: center;">Or</p>



BP 200102A

**GENERAL TERMS AND CONDITIONS OF ENQUIRY**

	f) Any goods rejected by BHEL must be removed by the supplier after making payment through NEFT / RTGS within 30 days after receipt of the intimation of rejection. If bidder fails to lift or allow despatch of rejected material at his cost within 90 days from the intimation of rejection, his claim on rejected material shall cease.
18	<b>Guarantee / Warranty and corresponding Repairs / Replacement of Goods</b>
A	Manufacturer's works test/inspection certificates shall be furnished along with the guarantee that material conforms strictly to the specification for general & special conditions as laid down in the purchase order. Goods shall comply with the specifications for material, workmanship and performance. The warranty shall be for a period of 12 months from the date of receipt. If the delivery is found non-compliant during the warranty period, leading to rejection, the Bidder shall arrange free replacement / repair of goods, within one month from the date of intimation or any mutually agreed period. The rejected goods shall be taken away by the Bidder at his cost and replaced on Delivered Duty Paid (DDP) (FOR - BHEL Stores/ designated destination basis) within such period. In the event of the Bidder's failure to comply, Purchaser may take action as appropriate, including Repair / Replenish rejected goods & disposal of rejections, at the risk & cost of the Bidder. In case the defects attributable to Bidder are detected during processing of the goods at purchaser's / his subcontractor's works, the Bidder shall be responsible for free replacement/ repair of the goods as required by the purchaser.
19	<b>Evaluation and Loading Criteria:</b>
A	The evaluation currency for this tender shall be INR. Evaluation of the tender shall be on the basis of delivered cost, i.e. 'total cost to BHEL' w.r.t the technical scope and commercial conditions finalized after techno-commercial clarifications (after considering, inter alia, Customs Duty and GST / Other taxes as applicable). Exchange rate (TT selling rate of State Bank of India) applicable on the date of Part-I bid opening shall be considered for evaluation of foreign bids. If the relevant day happens to be a bank holiday in India, then the FOREX rate as on the previous bank working day shall be taken for evaluation. Foreign suppliers shall ensure that the benefits as applicable under Comprehensive Economic Partnership Agreement (CEPA) with Government of India are disclosed in the bid & relevant documents such as Certificate of Country of Origin, issued by the appropriate authority in the country of Export, is provided by the bidder along with dispatch documents. Bids shall be evaluated with such applicable benefits. In the event of Bidder failing to provide appropriate documents for Purchaser to avail disclosed concessional duty benefits in India, financial loss, so incurred, will be to the Bidder's account.
20	<b>Variation of orders</b>
A	No variation to the Purchase order is permitted unless authorised in writing and signed by or on behalf of purchase executive, BHEL Bhopal.
21	<b>Sub-contract</b>
A	BHEL's order or part there off, if further to be subcontracted in exceptional circumstances the details of subcontracting and to whom to be subcontracted shall be furnished to BHEL and written permission shall be obtained from BHEL. However, it shall not absolve the supplier of the responsibility of fulfilling BHEL order requirements.
22	<b>Recovery / deductions of amount from supplier</b>
A	a Any amount on account of recovery from consignor / supplier under any condition shall be liable to be adjusted against any amount payable to the consignor/supplier against bills. b For any deficiency in supplies where deduction is involved, an amount as decided by BHEL, shall be deducted from supplier's bills.
23	<b>Safety clause for purchase orders</b>
A	The bidders shall maintain and ensure sufficient safety measures as required for inspections and test like HV test. Pneumatic test, Hydraulic test Spring test, Bend test, Material handling and safe working environment etc. to enable Inspection Agency for performing inspection. The bidder shall ensure that all the safety precautions specified in factories Act 1948 chapter-IV Section-21 to 41 are complied with respect to equipment's to be inspected. If any test equipment is found not complying with proper safety requirement, then the inspection agency may withhold inspection, till such time the desired safety requirements are met.
24	<b>Non-Disclosure Agreement</b>
A	All Drawing and technical documents relating to the product or it's manufacture submitted by one party to the other, prior or subsequent to the formation of contract, shall remain property of the submitting party. Drawing, technical documents or other technical information received by one party, shall not without the consent of the other party, be used for any other purpose than that, for which they were provided. Such technical information shall not without the consent of the submitting party, otherwise be used or copied, reproduced, transmitted or communicated to a third party. Patterns supplied by BHEL will remain BHEL's property which shall be returned by the bidder on demand to BHEL. Bidder shall in no way share or use such intellectual property of BHEL to promote his own business with others. <b><i>BHEL reserves the right to claim damages from the bidder, or take appropriate penal action as deemed fit against the bidder, for any infringement of the provisions contained herein.</i></b>



BP 200102A

**GENERAL TERMS AND CONDITIONS OF ENQUIRY**

	<p>DRAWINGS, PATTERNS &amp; TOOLS: All drawings, patterns &amp; tools supplied by BHEL or made at BHEL's expense are BHEL's property. These cannot be used or referred to any other party and must only be used in the execution of BHEL's orders. These should be preserved at the supplier's cost for a period of not less than 5 years. Patterns &amp; tools should be returned to BHEL within 90 days of issue of the same.</p>
25	<b>Settlement of Disputes &amp; Arbitration</b>
A	All questions/interpretations regarding subject matter of the Contract shall be decided by the Purchaser on the request of the Bidder and the decision of the Purchaser shall be final.
B	In case of dispute, steps shall be taken by the parties to the contract to settle the same through negotiations.
C	In case, dispute is not settled in negotiations, it shall be referred to Conciliator appointed by the competent authority of the Purchaser.
D	<p>Except as provided elsewhere in this Contract, in case amicable settlement is not reached between the Parties, in respect of any dispute or difference; arising out of the formation, breach, termination, validity or execution of the Contract; or, the respective rights and liabilities of the Parties; or in relation to interpretation of any provision of the Contract; or, in any manner touching upon the Contract, then, either Party may, by a notice in writing to the other party refer such dispute or difference to the sole arbitration of an arbitrator appointed by Head of the BHEL Unit/Region/Division issuing the Contract.</p> <p>The Arbitrator shall pass a reasoned award and the award of the Arbitrator shall be final and binding upon the Parties. Subject as aforesaid, the provisions of Arbitration and Conciliation Act 1996 (India) or Statutory modifications or re-enactments thereof and the rules made thereunder and for the time being in force shall apply to the arbitration proceedings under this clause. The seat of arbitration shall be Bhopal.</p> <p>The cost of arbitration shall be borne as per award of the Arbitrator.</p> <p>Subject to the arbitration in terms of Clause above, the Courts at Bhopal shall have exclusive jurisdiction over any matter arising out of or in connection with this Contract.</p> <p>Notwithstanding the existence or any dispute or differences and /or reference for the arbitration, the Contractor shall proceed with and continue without hindrance the performance of its obligations under this Contract with due diligence and expedition in a professional manner except where the Contract has been terminated by either Party in terms of this Contract. Administrative Mechanism for Resolution of CPSEs Dispute as stated in <a href="https://dpe.gov.in/guidelines/guidelines/chapters/2673">https://dpe.gov.in/guidelines/guidelines/chapters/2673</a>.</p> <p>In the event of any dispute or difference relating to the interpretation and application of the provisions of the commercial Contract between Central Public Sector Enterprises (CPSEs)/Port Trusts inter-se and also between CPSEs and Government Departments/Organizations (excluding disputes concerning railways, Income Tax, Customs and Excise Departments), such dispute or difference shall be taken up by either party for resolution through Administrative Mechanism for Resolution of CPSEs Disputes (AMRCD) as mentioned in Department of Public Enterprises (DPE) Office Memorandum No. 4(1)/2013-DPE(GM)/FTS-1835 dated 22-05-2018 as amended from time to time."</p>
E	The Bidder shall continue to perform the contract, pending settlement of dispute(s).
26	<b>Applicable Laws and Jurisdiction of Courts</b>
A	Indian laws both substantive and procedural, for the time being in force, including modifications thereto, shall govern the Contract including Arbitration proceedings. The competent Courts at Bhopal in the State of Madhya Pradesh, India shall have sole jurisdiction.
27	<b>RIGHT OF REJECTION /NON- PLACEMENT OF PO:</b> BHEL reserves the right to accept the offers in part or in full, or cancel the Tender enquiry without assigning any reason.
28	<b>Performance Bank Guarantee (PBG)/ Security Deposit (SD):</b>
A	Wherever PBG (covering equipment / system / work performance guarantee) is called for in the Notice Inviting Tender (NIT) deviation shall not be accepted.
B	Bank Guarantee wherever called for, shall be in the BHEL prescribed format. In case the order is to be placed in foreign currency, the BG must also be in Foreign currency, so specified by the Purchaser.
C	Wherever Security Deposit (covering contract performance) is called for in the NIT, deviation shall not be accepted.
D	Composite 'Contract Performance Bank Guarantee' of matching value/ validity, where both Security Deposit and Performance Bank Guarantee are required, shall not be construed as deviation.
E	Wherever the contract is for supply of Goods processed on labour basis from BHEL supplied materials, the materials shall be issued against a suitable Bank guarantee as specified in the Enquiry.
F	Bidder agrees to submit performance security required for execution of the contract within the time period mentioned. In case of delay in submission of performance security, enhanced performance security which would include interest (SBI rate + 6%) for the delayed period, shall be submitted by the bidder. Further, if performance security is not submitted such security, the amount of performance security due shall be covered as per terms defined in NIT/ contract , from the bills along with due interest.
29	<b>Benefits earmarked for Purchase from Micro &amp; Small Enterprises (MSEs) –</b>



BP 200102A

**GENERAL TERMS AND CONDITIONS OF ENQUIRY**

	<p>All benefits as per Government of India guidelines shall be given to eligible bidders.</p> <p>MSE bidders as defined by the MSMED Act as amended from time to time can avail the intended benefits only if they submit along with the offer, attested copies of relevant document stipulated in the MSMED Act or its rules/ regulations as amended from time to time and /or by the buyer. Non submission of such documents as stipulated hereinbefore will lead to consideration of their bids at par with other bidders. No benefit shall be applicable for the concerned for the tender enquiry, if any deficiency in the above required documents is not submitted before the price bid opening. If the tender is to be submitted through e-procurement portal, then the above required documents are to be uploaded on the portal. Documents should be notarized or attested by a Gazetted officer. This provision for MSE will apply subject to the condition that the participating MSE meets the tender requirements.</p> <p>In case of any change in the MSE status of the bidder, it shall be the responsibility of the bidder to notify the change as a part of the bid document. If at a later date it comes to the knowledge of BHEL, that the change in the status has not been intimated by the bidder and the order is obtained under the premise of an MSE then BHEL may reject the bid or, as the case may be, cancel the order and take necessary steps for suspension of the business dealing against the bidder as per the extant guidelines for suspension of business dealings with suppliers/ contractors of BHEL.</p> <p>Note: MSME benefits shall not be given to traders, Dealers or authorised agents.</p>
A	<p>MSEs shall be given tender documents free of cost and shall be exempted from payment of EMD. Tender documents shall be issued free of cost &amp; no EMD wherever called for will be insisted upon. MSE bidders shall submit along with bid relevant documents w.r.t. their respective MSE status as per extant norms. Date to be reckoned for determining the deemed validity will be the last date of Technical bid submission. Non- submission of such document will lead to consideration of their bid, at par with other bidders and MSE status of such bidders shall be shifted to Non- MSE supplier till the supplier submit these documents.</p>
B	<p>In tender, participating MSEs quoting price within price band of L1+15% shall also be allowed to supply a portion of requirement by bringing down their price to L1 price in a situation where L1 price is from someone other than a MSE and such MSE shall be allowed to supply up to at least 25% of total tendered value. In case of more than one such MSE, the supply shall be shared proportionately.</p> <p>A quantum of 6.25% (25% out of target of 25%), so earmarked, will be reserved for MSE's owned by SC / ST entrepreneurs who submit their bid with relevant documents provided that in event of failure of such MSE(s) to participate in tender process or meet tender requirements and L1 price, 6.25% sub-target for procurement earmarked for MSE(s) owned by SC or ST entrepreneurs shall be met from other MSE(s).</p> <p>A quantum of minimum of 3% reservation within the above mentioned 25% reservation, so earmarked, will be reserved for MSE's owned by women entrepreneurs who submit their bid with relevant documents provided that in event of failure of such MSE(s) to participate in tender process or meet tender requirements and L1 price, 3% sub-target for procurement earmarked for MSE(s) owned by women entrepreneurs shall be met from other MSE(s).</p> <p>In case of indivisible tender, the full quantity shall be awarded to L1.</p>
C	<p>If an enterprise falling under MSE category as defined in the MSMED Act 2006, graduates to a higher category from its original category or beyond the purview of the Act, it shall continue to avail all non-tax benefits of its original category notified by the Ministry of Micro, Small and Medium Enterprise for a period of three years from the date of such graduation to the higher category.</p>
D	<p>MSE suppliers can avail the intended benefits only if they submit along with the offer, attested copies of either EM II certificate having deemed validity (five years from the date of issue of acknowledgement in EM II) or valid NSIC certificate or EM II certificate along with attested copy of a CA certificate (As per BHEL Format, where deemed validity of EM II certificate of five years has expired) applicable for the relevant financial year (latest audited). Date to be reckoned for determining the deemed validity will be the date of bid opening (Part 1 in case of two part bid). Non submission of such documents will lead to consideration of their bid at par with other bidders. No benefits shall be applicable for this enquiry if any deficiency in the above required documents are not submitted before price bid opening. If the tender is to be submitted through e-procurement portal, then the above required documents are to be uploaded on the portal. Documents should be notarized or attested by a Gazetted officer</p> <p>MSE bidders as defined by the MSMED Act as amended from time to time can avail the intended benefits only if they submit along with the offer, attested copies of either EM II certificate/ Udyog Aadhar Memorandum certificate having deemed validity (five years from the date of issue in acknowledgement in EM II/ Udyog Aadhar) or valid NSIC certificate or EM II/ Udyog Aadhar certificate along with attested copy of a CA certificate (Format enclosed as per Annexure I where deemed validity of EM II certificate/ Udyog Aadhar certificate of five years have expired) applicable for the relevant financial year (latest audited) or such other document as may be stipulated in the MSMED Act or its rules/ regulations as amended from time to time and /or by the buyer. The deemed validity will be assessed on the date of bid opening (Part 1 in case of two part bid). Non submission of such documents as stipulated hereinbefore will lead to consideration of their bids at par with other bidders. No benefit shall be applicable for the concerned for the tender enquiry, if any deficiency in the above required documents is not submitted before the price bid opening. If the tender is to be submitted through e-procurement portal, then the above required documents are to be uploaded on the portal. Documents should be</p>



BP 200102A

## GENERAL TERMS AND CONDITIONS OF ENQUIRY

	<p>notarized or attested by a Gazetted officer. This provision for MSE will apply subject to the condition that the participating MSE meets the tender requirements.</p> <p>In case of any change in the MSE status of the bidder, it shall be the responsibility of the bidder to notify the change as a part of the bid document. If at a later date it comes to the knowledge of BHEL, that the change in the status has not been intimated by the bidder and the order is obtained under the premise of an MSE then BHEL may reject the bid or, as the case may be, cancel the order and take necessary steps for suspension of the business dealing against the bidder as per the extant guidelines for suspension of business dealings with suppliers/ contractors of BHEL.</p> <p>In case if all the items being procured under the enquiry fall under category of reserved items as defined in "Public Procurement Policy for Micro and Small Enterprises (MSEs) Order, 2012" and if any of the MSE bidder(s) is techno-commercially qualified then the price bids of only MSE bidders shall be opened. If no MSE bidder is techno-commercially qualified, then price bids of all techno-commercially qualified bidders shall be opened.</p>																								
30	<p><b>Integrity Pact (IP) — Independent external monitors (IEM)</b> For tenders in which integrity pact is applicable, following points stand valid :</p>																								
A	<p>IP is a tool to ensure that activities and transactions between the company and its bidders/contractors are handled in a fair, transparent and corruption free manner. A panel of Independent External Monitors (IEMs) have been appointed to oversee implementation of IP in BHEL.</p> <p>The IP as enclosed with the tender is to be submitted (duly signed by authorized signatory who signs in the offer) along with techno commercial bid. Only those bidders who have entered into such an IP with BHEL would be competent to participate in the bidding. In other words, entering into this pact would be a preliminary qualification.</p> <p>Name: ----- Address: ----- E-mail : -----</p> <p style="text-align: right;">} As indicated in NIT / enquiry</p>																								
B	<p>Please refer section 8 of the IP for roles and responsibilities of IEMs. In case of any complaint arising out of tendering process, the matter may be referred to the IEM mentioned in the tender.</p> <p><b>NOTE:</b> No routine correspondence shall be addressed to the IEM (phone / post/e-mail) regarding the clarifications, time extensions or any other administrative queries, etc. on the tender issued. All such clarifications/ issues shall be addressed directly to the tender issuing (procurement) department.</p> <p><b>For all clarifications/ issues related to the tender, please contact:</b></p> <table border="1" style="width: 100%; border-collapse: collapse;"> <thead> <tr> <th style="width: 60%;"></th> <th style="width: 20%; text-align: center;">( 1 )</th> <th style="width: 20%; text-align: center;">( 2 )</th> </tr> </thead> <tbody> <tr> <td><b>Name</b></td> <td></td> <td></td> </tr> <tr> <td><b>Landline No.</b></td> <td></td> <td></td> </tr> <tr> <td><b>Mobile No.</b></td> <td></td> <td></td> </tr> <tr> <td><b>Email</b></td> <td></td> <td></td> </tr> <tr> <td><b>Dept.</b></td> <td></td> <td></td> </tr> <tr> <td><b>Address</b></td> <td></td> <td></td> </tr> <tr> <td><b>Fax</b></td> <td></td> <td></td> </tr> </tbody> </table>		( 1 )	( 2 )	<b>Name</b>			<b>Landline No.</b>			<b>Mobile No.</b>			<b>Email</b>			<b>Dept.</b>			<b>Address</b>			<b>Fax</b>		
	( 1 )	( 2 )																							
<b>Name</b>																									
<b>Landline No.</b>																									
<b>Mobile No.</b>																									
<b>Email</b>																									
<b>Dept.</b>																									
<b>Address</b>																									
<b>Fax</b>																									
31	<p><b>Fraud Prevention Policy :</b> The Bidder along with its associate/ collaborators/ sub-contractors/ sub-bidders/ consultants/ service providers shall strictly adhere to BHEL Fraud Prevention Policy displayed on BHEL website <a href="http://www.bhel.com">www.bhel.com</a> and shall immediately bring to the notice of BHEL Management about any fraud or suspected fraud as soon as it comes to their notice.</p>																								
32	<p><b>Integrity Commitment:</b> The offers of the bidders who are under suspension as also the offers of the bidders, who engage the services of the banned firms, shall be rejected. The list of banned firms is available on BHEL website <a href="http://www.bhel.com">www.bhel.com</a>.</p> <p><b>Integrity commitment, performance of the contract and punitive action thereof :</b></p>																								
A	<p><b>Commitment by BHEL:</b> BHEL commits to take all measures necessary to prevent corruption in connection with the tender process and execution of the contract. BHEL will during the tender process treat all bidder(s) in a transparent and fair manner, and with equity.</p>																								
B	<p><b>Commitment by bidder / Supplier / Contractor :</b></p>																								
B1	<ul style="list-style-type: none"> <li>- The bidder / supplier / contractor commit to take all measures to prevent corruption and will not directly or indirectly influence any decision or benefit which he is not legally entitled to nor will act or omit in any manner which tantamount to an offence punishable under any provision of the Indian Penal code, 1860 or any other law in force in India.</li> <li>- The bidder / supplier / contractor will, when presenting his bid, disclose any and all payments he has made, and is committed to or intends to make to agents, brokers or any other intermediaries in connection with the award of the contract and shall adhere to relevant guidelines issued from time to time by govt. of India / BHEL</li> <li>- The bidder / supplier / contractor will perform / execute the contract as per the contract terms &amp; conditions and will not default without any reasonable cause, which causes loss of business / money / reputation to BHEL.</li> </ul>																								



BP 200102A

**GENERAL TERMS AND CONDITIONS OF ENQUIRY**

B2	If any bidder / supplier / contractor during pre-tendering / tendering / post tendering / award / execution / post-execution stage indulges in mal-practices, cheating, bribery, fraud or / and other misconduct or formation of cartel so as to influence the bidding process or influence the price or acts or omits in any manner which tantamount to an offence punishable under any provision of the Indian Penal Code, 1860 or any other law in force in India, then action may be taken against such bidder / supplier / contractor as per the extant guidelines of the company available on <a href="http://www.bhel.com">www.bhel.com</a> and / or under applicable legal provisions.
B3	<p><b>Preventive checks to eliminate suspected cartel formation between suppliers</b> The Bidder declares that they will not enter into any illegal or undisclosed agreement or understanding, whether formal or informal with other Bidder(s). This applies in particular to prices, specifications, certifications, subsidiary contracts, submission or non-submission of bids or any other actions to restrict competitiveness or to introduce cartelization in the bidding process. In case, the Bidder is found having indulged in above activities, suitable action shall be taken by BHEL as per extant policies/ guidelines</p> <p><b>Declaration by Bidders</b> We declare that the following family firms or sister concern affiliates/ subsidiary firms are participating in the tender No _____</p> <p>1.0 _____ 2.0 _____ 3.0 _____</p> <p>I _____ hereby declare on behalf of M/s _____ and family firms or sister concern affiliates/ subsidiary firms listed above that we are not indulging in cartel formation for Enquiry No _____.</p> <p style="text-align: right;">( _____ ) For M/s _____ Seal and Sign</p>
33	<p><b>Public Procurement (Preference to Make in India), Order 2017</b> For this procurement, Public Procurement (Preference to Make in India), Order 2017 Dtd 15.06.2017 and 28.05.2018 and subsequent orders issued by both DPIIT and the respective nodal ministries shall be applicable For this procurement, the local content to categorise a supplier as a Class I local supplier/ Class II local supplier / Non-Local supplier is as defined in Public Procurement (Preference to Make in India), Order 2017 dated 04.06.2020 issued by DPIIT. In case of subsequent orders issued by the nodal ministry changing the definition of local content for the items of the NIT, the same shall be applicable even if issued after issue of this NIT, but before opening of Part-II bids against this NIT.</p> <p><b>Bidder to mention the percentage of local content and place of value addition to manufacture these items in the tender.</b></p>
34	<b>RESTRICTION UNDER RULE 144 (xi) OF THE GENERAL FINANCIAL RULES 2017: As per latest government guidelines</b>
I	Any bidder from a country which shares a land border with India will be eligible to bid in this tender only if the bidder is registered with the competent authority.
II	“Bidder” (including the term ‘tenderer’, ‘consultant’ or service provider’ in certain contexts means any person or firm or company , including any member of a consortium or joint venture (that is an association of several persons , or firms or companies) every artificial juridical person not falling in any of the description of bidders stated hereinbefore, including any agency, branch or office controlled by such person, participating in procurement process.
III	Bidder from a country which shares a land border with India” for the purpose of this order means: - a. An entity incorporated, established or registered in such a country; or b. A subsidiary of an entity incorporated, established or registered in such a country; or c. An entity substantially controlled through entities incorporated, established or registered in such a county; or d. An entity whose beneficial owner is situated in such a country; or e. An Indian (or other) agent of such an entity; or f. A natural person who is a citizen of such a country; or g. A consortium or joint venture where any member of the consortium or joint venture falls under any of the above.



BP 200102A

**GENERAL TERMS AND CONDITIONS OF ENQUIRY**

IV	<p>The beneficial owner for the purpose of (iii) above will be as under:</p> <ol style="list-style-type: none"><li>1. In case of company or Limited Liability Partnership, the beneficial owner is the natural person(s), who, whether acting alone or together, or through one or more juridical person, has a controlling ownership interest or who exercises control through other means.</li></ol> <p>Explanation –</p> <ol style="list-style-type: none"><li>a. “Controlling ownership interest” means ownership of or entitlement to more than twenty-five per cent of shares or capital or profits of the company.</li><li>b. “Control” shall include the right to appoint majority of the directors or to control the management or policy decisions including by virtue of their shareholding or management rights or shareholder’s agreements or voting agreements.</li></ol> <ol style="list-style-type: none"><li>2. In case of a partnership firm, the beneficial owner is the natural person(s) who, whether acting alone or together, or through one or more juridical person, has ownership of entitlement to more than fifteen percent of capital or profits of the partnership;</li><li>3. In case of an unincorporated association or body of individuals, the beneficial owner is the natural person(s), who, whether acting alone or together, or through one or more juridical person, has ownership of or entitlement to more than fifteen percent of the property or capital or profits of such association or body of individuals;</li><li>4. Where no natural person is identified under (1) or (2) or (3) above, the beneficial owner is the relevant natural person who holds the position of senior managing official;</li><li>5. In case of a trust, the identification of beneficial owner(s) shall include identification of the author of the trust, the trustee, the beneficiaries with fifteen percent or more interest in the trust and any other natural person exercising ultimate effective control over the trust through a chain of control or ownership.</li></ol>
V	An Agent is a person employed to do any act for another, or to represent another in dealings with third person.
VI	<p>Model certificate for Tenders</p> <p><i>“I have read the clause regarding restrictions on procurement from a bidder of a country which shares a land border with India; I certify that this bidder is not from such a country or, if from such a country, has been registered with the competent authority. I hereby certify that this bidder fulfills all requirements in this regards and is eligible to be considered. [ Where applicable , evidence of valid registration by the Competent Authority shall be attached].”</i></p>

**Note:**

- 1.0 Tender Specific conditions shall override relevant provisions of this GTC
- 2.0 In the event of any change as notified by Govt. of India same will supersede.



MM 5533  
Rev-02

The BHEL Purchases Order subject to the following terms & conditions unless otherwise specified and directed.

#### 1. DOCUMENTATION :

##### 1.1 NON-NEGOTIABLE SET :

Comprising following :

- (i) Copy of non negotiable Bill of lading / AWB or HAWB with a mention of AWB No.
- (ii) 2 copies of Signed Commercial Invoice
- (iii) 2 copies of advice Note/detailed packing list in English covering each item and quantity
- (iv) Certificate of Origin
- (v) Inspection/Material Certificate
- (vi) Catalogue/drg. for components (including casting & forging) and for finished Goods.

OR

Composition certificate for ferrous/non-ferrous metals/insulating & other raw material, casting & forging and other metallic components.

##### 1.1.1 DOCUMENTATION CLAUSE :

\*Advance set of documents are to be forwarded to the following within three days of obtaining Bill of Lading/AWB through any international courier service so as to reach us within 10 days from the date of despatch of material. Failure to do so will make the supplier responsible for making good any loss. Please note that the insurance by BHEL does not absolve the supplier from the responsibility of defective/bad packing, short/wrong supply. Details like BL/AWB with date PO No. and value should be furnished by TLX/FAX/E-MAIL to the concerned Purchase officer of BHEL and to our underwriters.

- |   |   |
|---|---|
| <p>(i) <b>Sr. Manager (M.S.) ROD,</b><br/>Bharat Heavy Electricals Ltd.<br/>World Trader Centre, Centre 1<br/>14th/15th Floor Cuffe Parade, COLABA<br/>Mumbai 400 005, INDIA Tel: 2180740<br/>FAX : 0091-22-2187850</p> | <p>(ii) <b>Branch Manager,</b><br/>M/s. National Insurance Co. Ltd.<br/>First Floor, B-B, Indrapuri,<br/>Bhopal (INDIA) Pin - 462021<br/>Telex : 0705-336-NICL-IN,<br/>CABLE : NIC DIV-BHOPAL</p> |
| <p>(iii) <b>Dy. General Manager (CRX)</b><br/>BHEL, BHOPAL (INDIA) PIN-462022<br/>Telax : 0705-7264, 7265<br/>FAX : 0755-201823, 500946</p>   | <p>(iv) <b>Dy. General Manager (MM) Administrative</b><br/>Building, BHEL, BHOPAL (INDIA)<br/>PIN : 462022<br/>TELEX : 0705-7264, 7265<br/>FAX : 0755-500023<br/>(Two sets)</p>                   |

- 1.1.2 Fax/E-Mail confirmation indicating full details of shipment i.e., P.O.No., Vessel Name/Flight No. BL/AWB details, Material, Quantity and consignment value to be sent to other agencies as well at point 1.1.1. above, immediately after shipment/air freight.

##### 1.2 NEGOTIABLE SET :

- (i) Supplier should additionally forward documents mentioned at point 1.1 (ii to vi) alongwith original Bill to Lading through any international courier service/registered airmail or AWB by captain's mail within three days of obtaining the same, directly to the following :

- |  |  |
|--|--|
| <p>(i) <b>Sr. Manager (MS)</b><br/>Regional Operation Division BHEL,<br/>14th/15th Floors Centre 1<br/>World Trader Centre, Cuffe Parade,<br/>Colaba, Mumbai : 400 005 INDIA<br/>Fax : 0051-22-2187850</p> | <p>(ii) <b>Manager (FIN) FP</b><br/>Administrative Bldg. BHEL<br/>BHOPAL : 462022 INDIA<br/>Telex : 0705-7264, 7265<br/>Fax : 0755-540425 &amp; 201544</p> |
|--|--|
- and confirm forwarding details to Sr. manager (MM) FE, BHEL, Bhopal : 462 022 (INDIA)

##### 1.3 INSTRUCTIONS FOR DOCUMENTS :

- (i) Clean Bill of Lading/Copy of AWB in triplicate to be drawn as below :  
Shipper : Govt of India  
Consignee : BHEL, BHOPAL  
**Note : Bank not to be notified as consignee or joint Consignee.**
- (ii) B/L to be drawn on FOB basis as and freight to pay unless otherwise specified in P.O.
- (iii) In case of HAWB a mention should be made of AWB No. always.
- (iv) Signed Invoice should indicate quantity and value of all items supplied. If item is supplied in sets, the quantity and value of pieces making each set should be indicated. For supply of spares (including spares supplied with main equipment) sale value breakup should be indicated item wise. Split up value is a must together with consolidated value. Also item being supplied should be linked up with purchase order serial No. "Short shipments, if any, should be indicated clearly with quantity and value in the invoice. At the time of subsequent shipment of short shipped items, reference of original invoice should be indicated."

## BHARAT HEAVY ELECTRICALS LIMITED BHOPAL (INDIA) - 462022

### MATERIAL MANAGEMENT DEPARTMENT GENERAL TERMS & CONDITIONS FOR OVERSEAS PURCHASE ORDER

- (v) In case of Free supply : It should be indicated if supply is against short shipment or replacement together with earlier shipment details & forward documents as per 1.1 & 1.2 above, invoice should indicate value of material for customs purpose.
- (iv) Packing list should include package-wise details and each item clearly identified with the respective packing list.
- (vii) Any Demurrage/Wharfage paid at the ports because of delay/discrepancy in the above documents will be to the account of supplier or their representative.
- (viii) For correspondence & documentation, language must be ENGLISH or HINDI.
- (ix) DRG. & Patterns : All Drgs. and Patterns supplied/paid for by BHEL will remain BHEL property, and shall be returned to BHEL as and when demanded by BHEL.

#### 2. CASE MARKING :

Following details should be clearly marked on each case :

- (i) Shipper : Govt. of India.
- (ii) Consignee : BHEL (BHOPAL) Via MUMBAI (INDIA)
- (iii) BHELORDERNO. \_\_\_\_\_
- (iv) Port of Entry : \_\_\_\_\_
- (v) Port of Destination : \_\_\_\_\_
- (vi) Gross Weight \_\_\_\_\_ Kgs.
- (vii) Nett Weight \_\_\_\_\_ Kgs.
- (viii) Brief Description : \_\_\_\_\_
- (ix) Dimension in MM : \_\_\_\_\_
- (x) Supplier : \_\_\_\_\_

#### 3. PACKING :

Material should be packed suitably in all for normal transport by SEA/Air (as case may be) to India and subsequently by Rail/Road to destination point in India. It should be suitably protected against the effects of tropical salt laden climate. Timber in packing should be free from bark, insects and fungi. Special packing should be provided wherever required in addition to above. Damage to the consignment of account of poor/inferior packing shall be to the account of supplier or their representative.

##### 3.1 INSTRUCTION FOR PACKING :

- (i) A broad red band about 100mm (4") wide all round the case just below top for easy identification of BHEL package at the docks, should be painted.
- (ii) All marking for safety, handling, storage and protection etc. are to be clearly marked on the cases as per international practice.
- (iii) A special care should be taken in packing of hazardous material with all precaution for safety.
- (iv) Proper care should be taken to ensure correct case marking and packing should be in accordance with the details in Advice Note/Packing list. Any delay in clearance because of wrong case marking will be to the account of supplier or their representative. Similarly, if for any reason whatsoever discrepancies are noticed prejudicing our claim with underwriters/carriers with consequential loss will also be to the account of supplier or their representative.

#### 4. MODE OF DESPATCH :

By Sea / Air as specified in purchase order.

#### 4.1 BY SEA :

Following conditions will apply in case of shipments from different countries.

- (a) **FROM JAPAN :** Shipping arrangements will be made by Secretary, Shipping Coordination Committee, Ministry of Shipping & Transport, New Delhi (India) Cable: TRANSCART NEW DELHI. Fax No. 011-3718614, 3352726, Through First Secretary (Commercial) Embassy of India, Tokyo, Japan.
- (b) **FROM USA/Canada/Mexico/South America,** Shipment to be arranged per IPBC conference vessel through M/S OPT OVERSEAS PROJECT TRANSPORT, INC. (A THYSSEN HANIEL LOGISTIC CO.) 46 SELLERS STREET, KEARNY, N.J. 07032 TEL : (201) 998-7771, Tlx : 673-3586, fax : (201) 998-7833.
- (c) **FORM OTHER THAN USA/CANADA/MEXICO/SOUTH AMERICA & JAPAN :** Shipment to be arranged per IPBC vessel through M/s. Schenker & International, Deutschland GmbH, Beiden Muhren 520457, Hamburg Germany, Fax : 0049-4036135509, their agent in UK are M/s. Schenker Ltd., Royal London House, 13 Finsbury Square, London E2 2OR obtain a certificate from them to the effect that

shipment has been arranged in accordance with instructions of the Ministry of Shipping & Transport, NEW DELHI.)

#### 4.1.1 INSTRUCTIONS FOR DESPATCH :

- (i) Despatch per Post Parcel is strictly prohibited.
- (ii) Four weeks' notice to be given to shipping Agents about readiness of cargo for finalising the shipping arrangements. Bank not to be notified as-Consignee or Joint Consignee.
- (iii) Material to be shipped free on board (FOB). Inland freight, packing forwarding etc. to be borne by Supplier other than USA Suppliers who will ship the material on FAS basis.
- (iv) Material will be shipped as break bulk FCL cargo. Specific advice of BHEL, Bhopal shall be necessary for shipping on FCL cargo basis.

#### 4.2 BY AIR :

Material to be airfreighted through our authorised agents/air consolidators as indicated in the Purchase Order/Letter of Credit. In countries where no authorised agent/consolidators exists, supplier himself will arrange shipment through AIR INDIA flight. Refer Documentation Clause for other details.

#### 5. INSURANCE :

Material insurance will be arranged by us at our cost against open Marine Cover obtained from M/s. National Insurance Co. Ltd., Bhopal (India) and advance set of documents should be airmailed directly to them (See Clause 1.1.1)

#### 6. GUARANTEE & TEST CERTIFICATE :

Manufacturer's works test/inspection certificates shall be furnished alongwith the guarantee that material conforms strictly to the specification for general & special conditions as laid down in the purchase order

#### 7. PENALTY :

Failure to despatch in time as per the terms of delivery mentioned in our order would be liable for supplier, unconditional penalty of 1/2% (half percent) of the price of the goods offered in arrears per week at the discretion of BHEL subject to a maximum of 10% value of the order.

#### 8. DEFICIENCIES & DEFECTIVE GOODS :

Should any deficiency or defect be noticed in the goods same shall be replaced by the supplier without any extra charge under NO CHARGE INVOICE. Any complaint in regard to the material will be notified to the supplier who will replace same promptly. The rejected material will have to be accepted back by the supplier who will bear its return freight also & the supplier will reimburse to BHEL the customs duty paid on defective supply and/or unnotified short shipments."

#### 9. PAYMENT :

Generally through Irrevocable letter of credit as per detailed terms and conditions mentioned therein to be established by BHEL.

#### 10. AGENCY COMMISSION :

Agency Commission, if any, will be paid out of the FOB value after receipt and acceptance of material on inspection, in Indian Rupees on submission of invoice. Exchange rate considered for calculation will be the rate prevailing on the tender opening date or the letter of intent date or date of purchase order, whichever is the lowest.

#### 11. LAWS :

The contract shall be governed by the laws of India

#### 12. ARBITRATION :

All cases of dispute arising out of or relating to this purchase order shall be referred to the sole arbitration of the Executive Director/General Manager/Incharge, General Manager of BHEL, Bhopal or any other person (including an employee of BHEL, even though he had to deal with the matters relating to this Purchase order in any Manner) nominated by the said Executive Director/General Manager (In)General Manager to act as sole Arbitrator. The arbitration shall be under the Indian arbitration act, 1940 and rules made there under. The arbitrator may from time to time with consent of parties enlarge the time for making and publishing the award. Seat of arbitration shall be Bhopal.

#### 13. JURISDICTION :

All suits or any matters arising out of this purchase order shall lie in Bhopal Courts only.

14. In line with factories Act, section 41-B and Environment Act schedule 9, Rule 17, and as per the requirement of ISO-14001, please submit the material safety Data sheet (MSDS) of hazardous chemicals being imported, This is required to be kept ready by us for producing as and when asked for by regulating inspecting Government Authorities.



FORM NO. MM 5627

Rev - 03

**B.H.E.L., P.O. TERMS & CONDITIONS (INDIGENOUS)**

The purchase order is subject to the following terms &amp; conditions unless otherwise specified and directed :-

**1. ORDER ACKNOWLEDGEMENT :**

Order acknowledgement in the enclosed format must reach the concerned officer of Materials Management Divisions within 4 weeks of issue of purchase order. Failure to do so within stipulated period will be deemed to mean that the order has been accepted by the supplier.

**2. PACKING :**

a) The supplier shall securely protect and pack the goods against loss, damage or corrosion in transit. Packing shall allow for easy removal and checking on site and comply with carrier conditions of packing or established trade practice.

b) Cases and packing materials shall be supplied free of charge unless otherwise agreed to. Wherever specifically agreed to, empties shall be returned at suppliers expenses but no liability will be accepted by BHEL in respect thereof.

c) Damage to the consignment resulting out of poor/inferior packing shall be to the account of the supplier.

**3. MARKING :**

a) The following details to be clearly marked on each case/box/packing/bundle and reel.

i) Consignee ii) BHEL Order No. iii) Gross weight iv) Net weight v) Dimensions in CMS vi) Brief description of item vii) BHEL Destination Code (refer purchase order) viii) Consignor.

b) All markings for safety, proper handling, storage, protection etc. are to be clearly marked on the case as per Indian Standard.

**4. CONSIGNMENT :**

Unless otherwise mentioned, all goods shall be consigned as noted below :

a) Rail : Sr. Manager, Central Receiving Section, HESG Central Railway via Bhopal.

Note : Goods must not be consigned to Bhopal Station, HESG via Bhopal in an assisted siding in IRCA Chapter VIII page 373. All goods in small or wagon loads should be booked to this siding.

b) Road : Sr. Manager, Central Receiving Section Block VII, BHEL Despatches must be arranged through BHEL's approved transporters on door delivery basis.

c) Post/Air parcel : Sr. Manager Central Receiving section Block VII, BHEL, Bhopal - 462 022.

d) Supplier not complying with instructions at (a), (b) & (c) above shall do so at their risk and cost.

**5. PRICE :**

Unless specifically agreed to other wise, all prices shall be treated as FIRM.

**6. TERMS OF PAYMENT :**

The standard payment terms shall be as specified below and specified in the Purchase Order. It is however made clear that BHEL shall not accept any interest liability.

**A. Local ancillary and SSI Units and other local parties.**

100% payment on receipt and acceptance of Materials within 90 days of the date of receipt in BHEL.

**B. Outstation SSI and other Suppliers.**

BHEL prefers "door delivery of material in which case payment shall be within 90 days from the date of despatch. In case documents through Bank 100% payments within 90 days from the date of despatch of Material. Delivery at our works.

In case of Payments through other negotiable instrument like Bill of Exchange/Hurdles etc. then the Material be delivered on "door delivery" basis. 100% payment within 80 days from date of acceptance of negotiable Bill, of Exchange/Hurdles. Hurdles will be accepted by BHEL within 7 days of presentation or otherwise in accordance with contract.

नोट - भुगतान के पंजीकृत हक द्वारा भेजा जायेगा। डाक विमान द्वारा भेज दिये जाने से पूर्व विवेकपूर्वक भुगतान-कार्रवाई या अन्य कारणों से अनधिकृत हार्दों के द्वारा भुगतान पर हार्दों के लिए कोई भी रकम वास्तविक नहीं होगी।

NOTE - The cheque will be sent by Registered post and the Company will in no way be responsible, if loss occurs due to delay by postal authorities or cheque falling into improper hands through forgery of fraud.

**7. DOCUMENTATION :**

The supplier shall forward four sets of the document as detailed below :-

a) 1 set to the concerned Purchase officer, Materials management Deptt. 2nd floor Administrative Building, BHEL Bhopal-462 022, Comprising of

- |                                      |          |
|--------------------------------------|----------|
| i) Invoice                           | 1 copy   |
| ii) Challan/Despatch Advice note     | 2 copies |
| iii) Guarantee Certificate           | 3 copies |
| iv) Test Certificate                 | 4 copies |
| v) Proforma for insurance            | 2 copies |
| vi) Photo copy of ED Paying Document | 1 copy   |
| vii) Photo copy of LR/RR             | 1 copy   |

b) 1 set to Dy. General Manager, Central Receiving Section, Block-VII, BHEL, Bhopal-462 022 comprising of :-

- |  |        |
|--|--------|
| i) Original LR/RR (if not negotiated through Bank) |        |
| ii) Invoice  | 1 copy |
| iii) Challan/Despatch advice note                  | 1 copy |
| iv) Excise Duty Paying document (Excise challan)   |        |

c) 1 set to Dy. Manager Purchase Bills Section, 4th floor Administrative Building BHEL, Bhopal-462022 comprising of :-

- |  |          |
|--|----------|
| i) Signed invoice                                      | 2 copies |
| ii) Excise Duty Paying Document (duplicate/photo copy) | 1 copy   |

d) 1 set to the bank in case of documents negotiated through Bank separately to each Purchase order comprising of :

- |   |          |
|---|----------|
| i) Original RR/LR   |          |
| ii) Signed Invoice  | 2 copies |
| iii) Original Excise duty Paying Document (only in case of rail despatches) |          |
| iv) Test Certificate  | 1 copy   |
| v) Guarantee certificate  | 1 copy   |

**Note :**

'C' form shall be issued directly to the supplier. No 'C' form shall be exchanged against documents through Bank. This will be issued once in a year against a P.O.

In case of materials going to site directly, 'C' form will be issued after suppliers confirmation that he will issue corresponding E1 form.

8. **Excise only :** The original Excise duty paying document or equivalent document indicating tariff Item No. and drawn in favour of BHEL, Bhopal for each consignment shall accompany the transporters in case of road despatches and with R/R in case of rail despatches. In case of any other mode of despatch (such as Regd. Post Parcel /Air Parcel etc.) the same shall be forwarded to Sr. Manager, Central Receiving Section, Block VII, BHEL, Bhopal-462 022 directly by registered post/hand delivery. The Excise duty paying document must not be enclosed inside the packing case. No Excise Duty shall be paid in the absence of the above document.

**9. SALES TAX :**

BHEL Bhopal is registered as a manufacturer under Sales Tax registration No. BPH/HEL/11, MPST No. BPL/HKLS. Sales Tax declaration form will be issued as per rules. Supplier is to furnish E-1 form within 15 days after receipt of 'C' form in favour of Sr. Mgr. (Sales Tax) Materials Management Deptt. for the despatches direct to customers i.e. Destination other than BHEL Bhopal. Otherwise full CST & Penalty will be paid by Supplier.

**10. INSURANCE :**

In all cases Supplier must furnish despatch particulars for each consignment in the format enclosed with the purchase order in duplicate by registered post to Sr. Mgr. (M.M.) concerned, Administrative Building, BHEL, Bhopal-462 022 and one form to Branch Manager, M/s National Insurance Co. Ltd., First Floor & Indrapuri, Bhopal-462 021 immediately after despatch of material. The documents should reach within 10 days from the date of despatch. Failure to do so will make the supplier responsible for making good any loss. Please note that insurance by BHEL does not absolve the suppliers from the responsibility of defective bad packing, short/wrong

supply. Wherever possible despatch particulars like MR with date, PO No. and value should be furnished by TLX. TLG to Sr. Mgr. concerned group and to our underwriters (Gram : National Insurance TLX : 0705-336 cable/NIC Div.

**11. QUALITY :**

All the goods supplied and services rendered must be the best of their kind and conform to the specification mentioned in the order and/ or to be strictly in accordance with approved samples or drawings.

**12. INSPECTION :**

All the goods and works are subject to BHEL's inspection or where stipulated by BHEL's client or his authorised nominees at supplier works. Despatch can be arranged against despatch clearance note issued by BHEL inspection and/or customer's representative. However final acceptance is subject to inspection and acceptance at the destination.

**13. TEST CERTIFICATE :**

All certificates called for in the specification or order must be sent by Registered Post with the Advice Note. BHEL may test any goods supplied and their decision is final irrespective of supplier's certificates.

If test certificate and guarantee certificate are not received alongwith the document and stipulated in these specifications, BHEL reserves the right to get the material tested and recover the expenses from the supplier without awaiting suppliers confirmation.

**14. GUARANTEE :**

All goods shall be free from any defect due to faulty design/material and / or workmanship/erection (Where called for) and will be guaranteed for a period of twelve months from the date of commissioning of the goods or 24 months from the date of despatch whichever is earlier. However, for any "Type defects" Supplier will be responsible even after 24 months, if failure of the item on a/c of this.

Where the contract stipulates submission of Bank guarantee the Suppliers shall get validity period of the same extended from the Bank as and when required, failing which it will be treated as Breach of the terms of the contract and the contract is liable to be cancelled and the loss suffered by BHEL shall be recoverable from the supplier.

**15. REJECTION :**

If any goods are rejected, BHEL shall be at liberty to take action as per following at the risk and cost of supplier:

a) Allow the supplier, where ever mutually agreed, to rectify the rejected goods at BHEL's work within reasonable time as fixed by BHEL.

b) Allow the supplier to make free replacement within a specified period. Rejected goods can be lifted by the supplier thereafter.

c) Allow supplier to refund the full amount paid to him by BHEL by a demand draft before lifting the rejected goods. Fresh replacement shall be regulated as per terms and condition of the original Purchase Order.

d) Take alternate procurement action from elsewhere and recover the difference in cost. If any, incurred by BHEL in this regard from the supplier. The supplier shall not be entitled to any gain on repurchase.

e) Terminate the contract either in part or in whole at the discretion of BHEL and recover the loss if any from the supplier.

f) Any goods rejected by BHEL must be removed by the supplier after making payment through Demand Draft within 45 days from the date of intimation of rejection or 30 days after receipt to of the intimation of rejection which ever is earlier. If the goods are not removed within the period stipulated above, the goods shall be liable to be sold by BHEL and the proceeds there of shall be adjusted towards storage charge and or other dues.

**16. DRAWINGS, PATTERNS & TOOLS :**

All drawings as also all patterns and tool supplied by BHEL or made at BHEL's expense are BHEL's property. These cannot be used or referred to any other party and must only be used in the execution of BHEL's orders. These should be preserved at the supplier's cost for a period of not less than 5 year.

**17. INDEMNITY :**

Supplier shall indemnify BHEL against the following:

a) Any claim or infringement of letters, patent or registered design by the use or sale of any article or materials supplied to BHEL and against all costs and damages which may incur in any action for such infringement or for which BHEL become liable in any such action.

b) All claims for injury or damages caused by the suppliers negligence or the negligence of supplier's employee or arising from any defect in the goods supplied or on the work carried out the supplier.

c) All claims for injury to the supplier's employees or agents employees whilst on BHEL premises.

**18. SUB-CONTRACT :**

BHEL's order or part there off, if further to be subcontracted in exceptional circumstances the details of subcontracting and to whom to be subcontracted shall be furnished to BHEL and written permission shall be obtained from BHEL. However it shall not absolve the supplier of the responsibility of fulfilling BHEL order requirements.

**19. VARIATION OF ORDERS :**

No variation to this order is permitted unless authorised in writing and signed by or on behalf of purchase executive, BHEL Bhopal.

**20. LIQUIDATION DAMAGE/PENALTY :**

a) Failure to effect supply by the time specified in the order or period of extension granted in writing by BHEL will make the supplier liable to pay liquidated damage/unconditional penalty, as the case may be, of 1/2% (Half Percent) of the price of the goods in arrears per week at the discretion of BHEL, subject to a maximum of 10% of the order value.

b) If the material is not supplied within stipulated time BHEL shall be within their right to cancel the contract and purchase, the material through any other source at the risk and cost of the supplier. In such an event it shall be obligatory on the defaulting supplier to make good any loss suffered by BHEL.

**21. ADJUSTMENT OF RECOVERY OF AMOUNT PAYABLE BY THE SUPPLIER :**

Any amount payable by the consignor/supplier under any of the condition of this contract shall be liable to be adjusted against any amount payable to the consignor/supplier under any other works/contract awarded to him. This is without prejudice to any other action as may be deemed fit by BHEL.

**22. JURISDICTION :**

All suits or any matters arising out of this purchase order shall be lie in BHOPAL COURTS ONLY.

**23. ARBITRATION :**

In all cases of disputes emanating from and in reference to this Purchase Order the matter shall be referred to the arbitration of the sole arbitration of the Executive Director/ GM of BHEL, Bhopal or any other person (including an employee of BHEL, even though he had to deal with the matter relating to this P.O. in any manner) nominated by the said Executive Director/ GM to act as sole arbitrator. The arbitration shall be under 'THE ARBITRATION AND CONCILIATION ACT OF 1996' and the rules there under. The arbitrator may from time to time with the consent of the parties enlarge the time for making and publishing the award.

**24. HAZARDOUS/TOXIC CHEMICALS :**

Supplier to supply the "Material Safety Data Sheet (MSDS)" in the standard prescribed proforma as per the environment act Schedule-9 Rule 17, Manufacture, Storage And IMPORT of chemicals Rule-1989.

**25. SAFETY CLAUSE FOR PURCHASE ORDERS :**

The vendors shall maintain and ensure sufficient safety measures as required for inspections and test like HV test, Pneumatic test, Hydraulic test, Spring test, Bend test, Material handling and safe working environment etc. to enable Inspection Agency for performing inspection.

The vendor shall ensure that all the safety precautions specified in factories Act 1948 Chapter-IV Section-21 to 41 are complied with respect to equipments to be inspected.

If any test equipment is found not complying with proper safety requirements, then the inspection agency may with hold inspection, till such time the desired safety requirements are met.