

PLAN

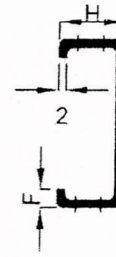

SEC- 'C' 'C'

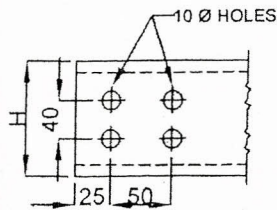

**SEC - 'A'-'A' FOR
600, 450 & 300MM
WIDTH TRAY**

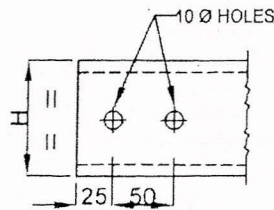

**SEC - 'A'-'A' FOR
150MM WIDTH TRAY**

WIDTH (W) :	600	450	300	150
HEIGHT (H) :	100	100	75	50
FLANGE (F) :	15	15		

PERFORATED TYPE CABLE TRAY (GALVANIZED/SS)

NOTE :

- 1) FOR NOTES REFER SHEET 20 OF 22.
- 2) CABLE TRAY SHALL BE FABRICATED FROM MS / SS SHEET

TITLE:

Typical details of Cable Tray & its Accessories
along with cable rack assembly.

DRG. NO. : HPE/01

REV-02

SH. 1 OF 22

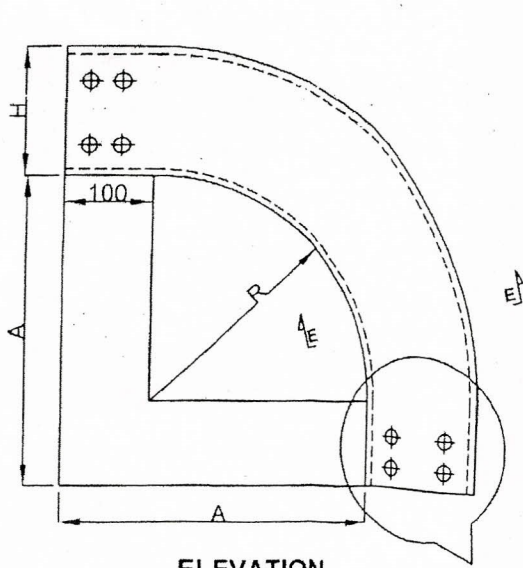

ELEVATION
90° VERTICAL ELBOW
(OUT SIDE)
PERFORATED TYPE

DETAIL 'X'

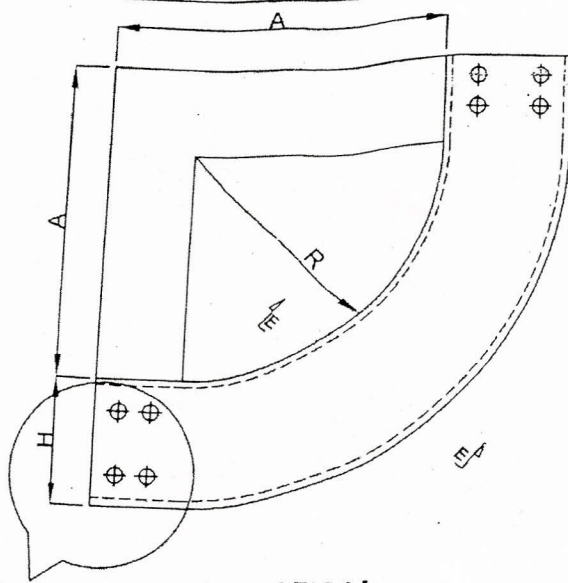

ELEVATION
90° VERTICAL ELBOW
(IN SIDE)
PERFORATED TYPE

DETAIL 'X'

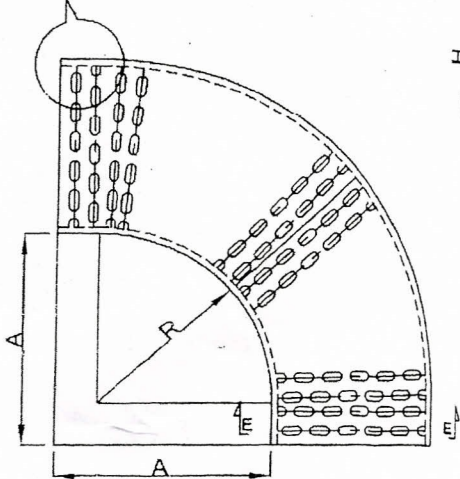

PLAN
90° HORIZONTAL ELBOW
PERFORATED TYPE

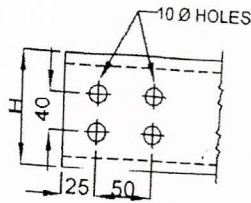

DETAILS - 'X'



SEC - 'E'E'

WIDTH (W) :	600	450	300
HEIGHT (H) :	100	100	75
FLANGE (F) :	15	15	
RADIUS (R) :	600	600	600
'A' :	700	700	700

NOTE :

- 1) FOR NOTES REFER SHEET 20 OF 22.
- 2) CABLE TRAY ACCESSORIES SHALL BE FABRICATED FROM MS / SS SHEET

TITLE:

Typical details of Cable Tray & its Accessories
 along with cable rack assembly.

DRG. NO. : HPE/01

REV-02

SH. 2 OF 22

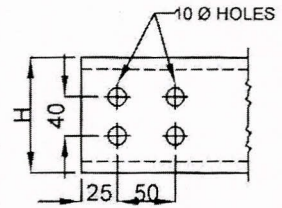
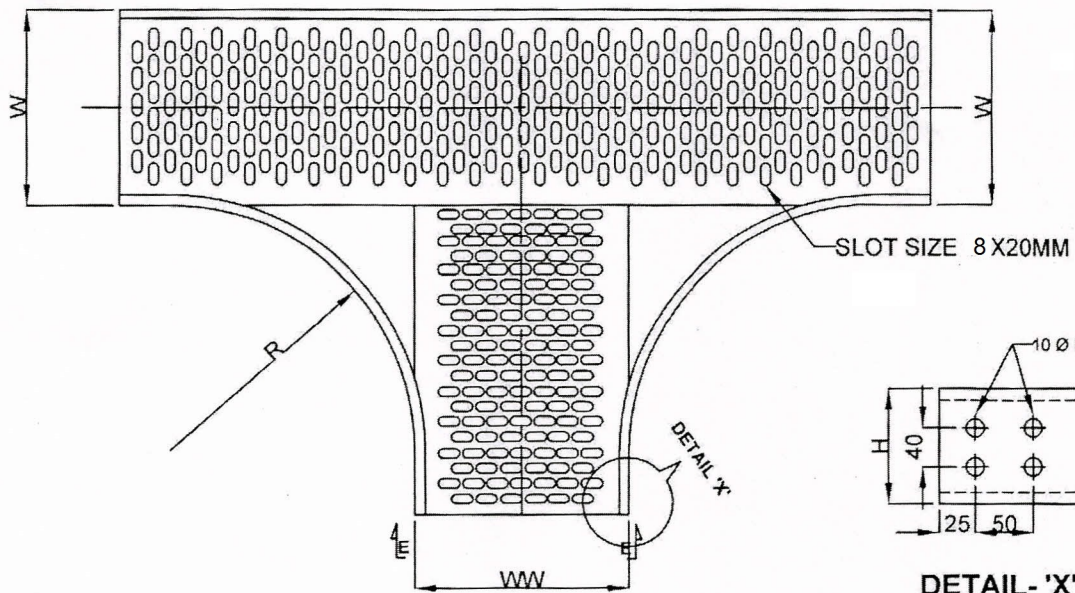

DETAIL - 'X'

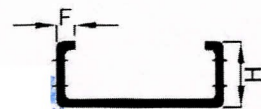

SEC - 'E'E'

**PLAN
90° HORIZONTAL TEE
PERFORATED TYPE**

TABLE FOR HORIZONTAL TEE :			
WIDTH (W) :	600	450	300
WIDTH (WW) :	600	450	300
HEIGHT (H) :	100	100	75
FLANGE (F) :	15	15	
RADIUS (R) :	600	600	600

TABLE FOR HORIZONTAL TEE REDUCER :					
WIDTH (W) :	600	600	450	300	300
WIDTH (WW) :	450	300	600	600	450
HEIGHT (H) :	100	100	100	100	100
FLANGE (F) :	15	15	15	15	15
RADIUS (R) :	600	600	600	600	600

NOTE :

- 1) FOR NOTES REFER SHEET 20 OF 22.
- 2) CABLE TRAY ACCESSORIES SHALL BE FABRICATED FROM MS / SS SHEET

TITLE:

Typical details of Cable Tray & its Accessories
along with cable rack assembly.

DRG. NO. :HPE/01

REV-02

SH. 3 OF 22

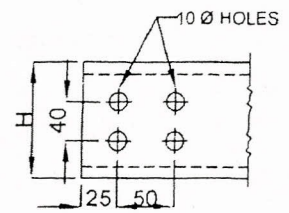
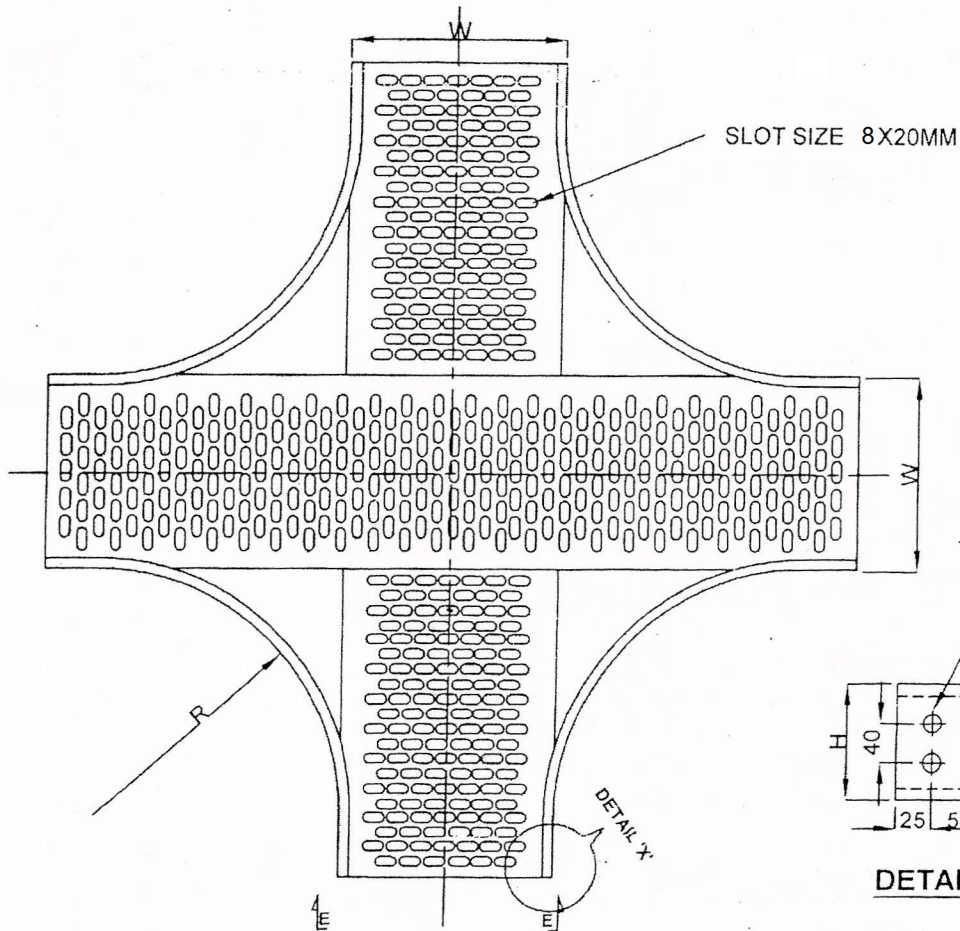

DETAIL - 'X'

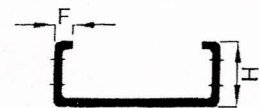

SEC - 'E'E'

**PLAN
90° HORIZONTAL CROSS
PERFORATED TYPE**

TABLE FOR EQUAL CROSS :			
WIDTH (W) :	600	450	300
HEIGHT (H) :	100	100	75
FLANGE (F) :	15	15	
RADIUS (R) :	600	600	600

NOTE :

- 1) FOR NOTES REFER SHEET 20 OF 22.
- 2) CABLE TRAY ACCESSORIES SHALL BE FABRICATED FROM MS/ SS SHEET

TITLE:

Typical details of Cable Tray & its Accessories
along with cable rack assembly.

DRG. NO. ; HPE/01

REV-02

SH. 4 OF 22

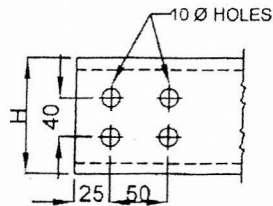
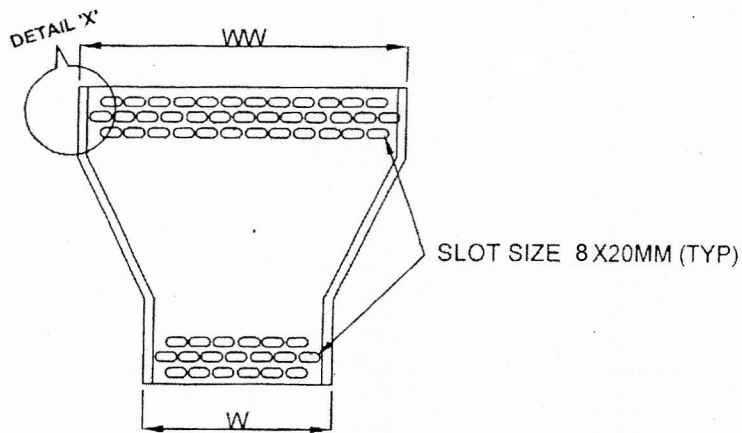

DETAIL- 'X'

**PLAN
REDUCER PERFORATED TYPE**

TABLE FOR REDUCER :			
WIDTH (WW) :	600	600	450
WIDTH (W) :	450	300	300
HEIGHT (H) :	100	100	100
FLANGE (F) :	15	15	15

NOTE :

- 1) FOR NOTES REFER SHEET 20 OF 22.
- 2) CABLE TRAY ACCESSORIES SHALL BE FABRICATED FROM MS/ SS SHEET

TITLE:

Typical details of Cable Tray & its Accessories
along with cable rack assembly.

DRG. NO. : HPE/01

REV-02

SH. 5 OF 22

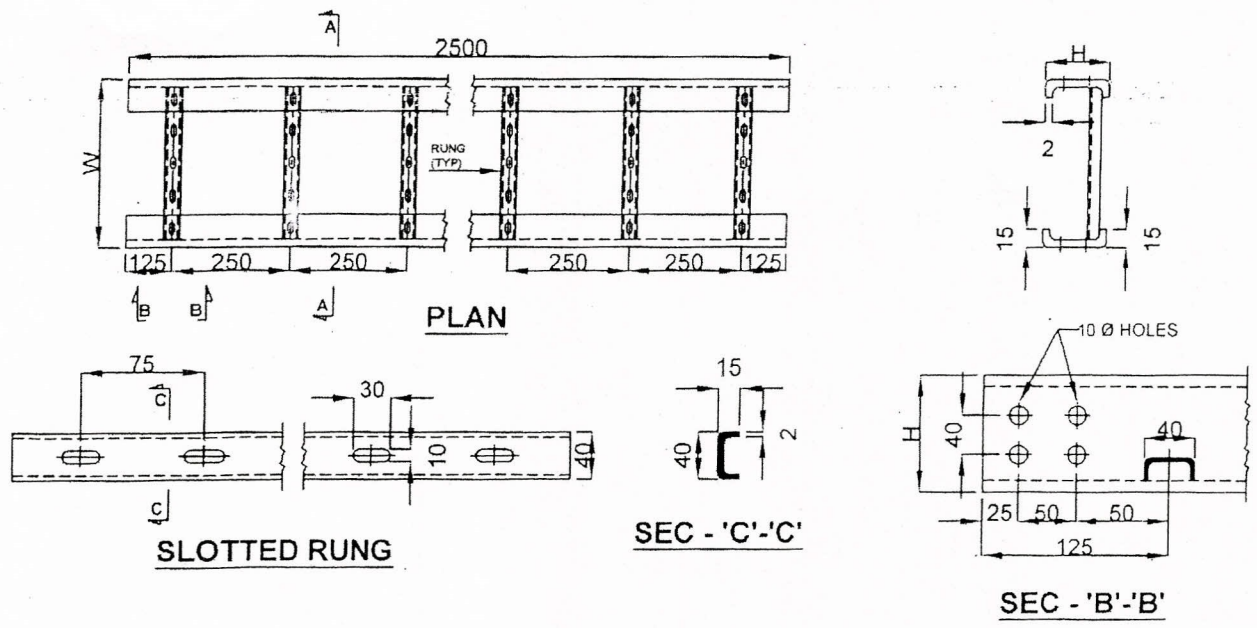

GALVANIZED LADDER TYPE CABLE TRAY

WIDTH (W) :	600	450	300
HEIGHT (H) :	100	100	75

NOTE :

- 1) FOR NOTES REFER SHEET 20 OF 22.
- 2) CABLE TRAY SHALL BE FABRICATED FROM MS / SS SHEET

TITLE: Typical details of Cable Tray & its Accessories along with cable rack assembly.	DRG. NO. : HPE/01	REV-02
	SH. 6 OF 22	

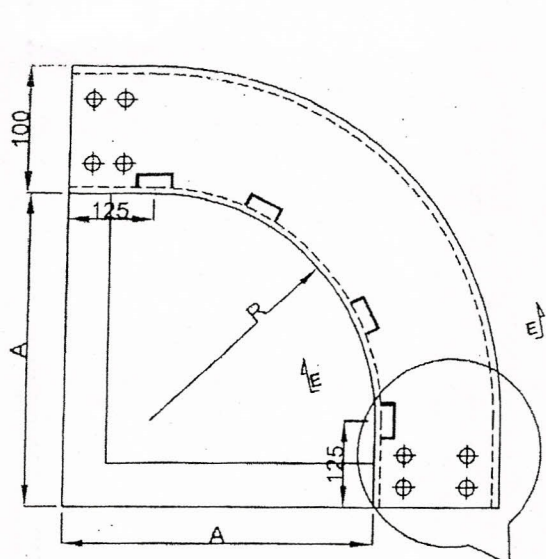

**ELEVATION
90° VERTICAL ELBOW
(OUT SIDE)**

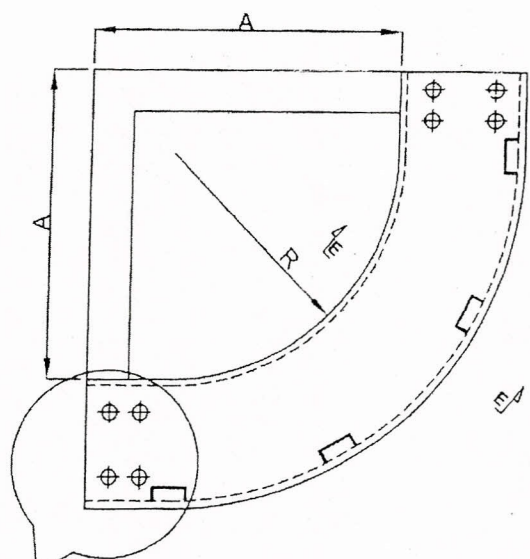

**ELEVATION
90° VERTICAL ELBOW
(IN SIDE)**

DETAIL 'X'

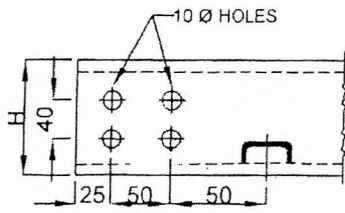

DETAILS- 'X'

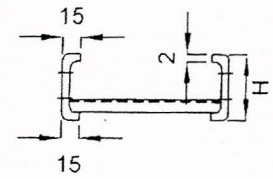

SEC - 'E''E'

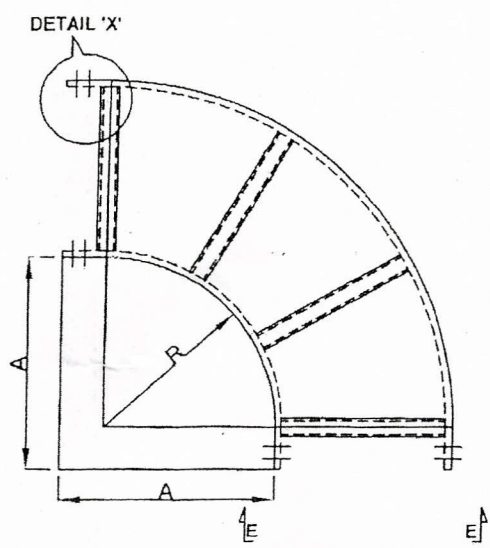

**PLAN
90° HORIZONTAL ELBOW**

WIDTH (W) :	600	450	300
HEIGHT (H) :	100	100	75
RADIUS (R) :	600	600	600
'A' :	700	700	700

NOTE :
1) FOR NOTES REFER SHEET 20 OF 22.
2) CABLE TRAY ACCESSORIES SHALL BE FABRICATED FROM MS / SS SHEET

TITLE: Typical details of Cable Tray & its Accessories along with cable rack assembly.	DRG. NO. : HPE/01	REV. 02
	SH. 7 OF 22	

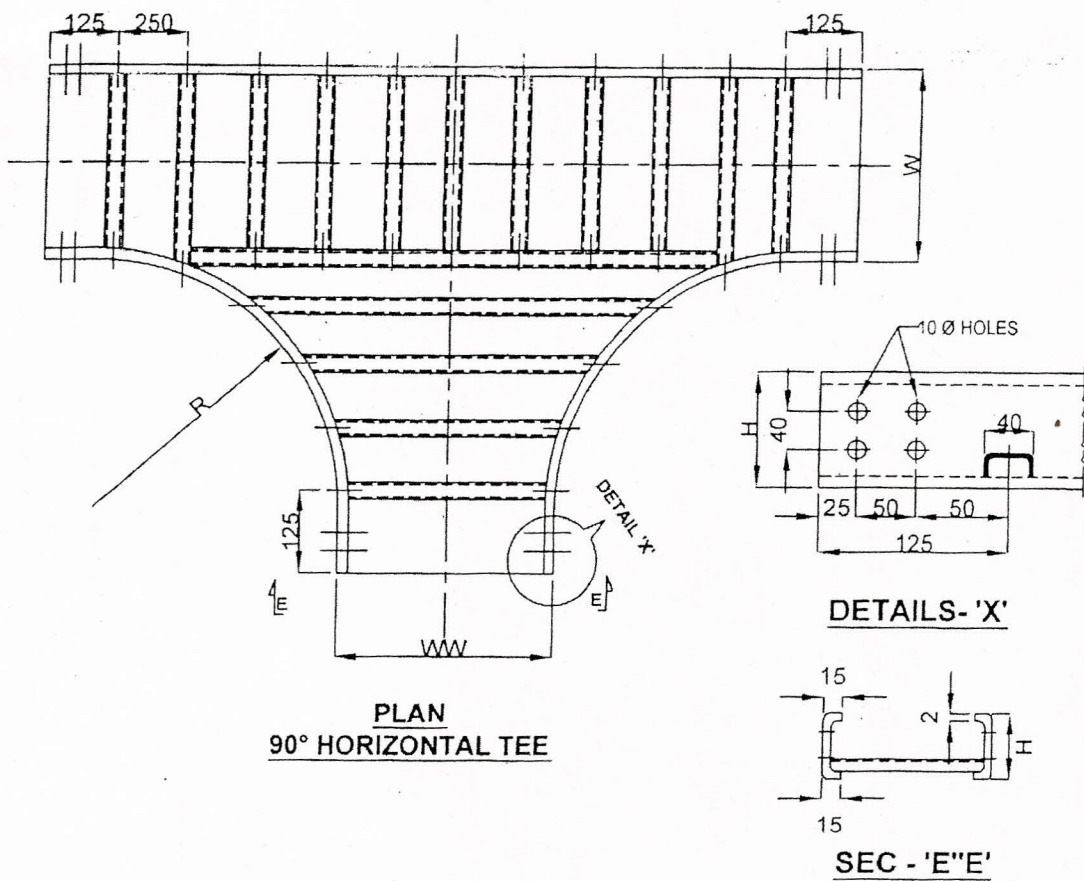

TABLE FOR HORIZONTAL TEE :			
WIDTH (W) :	600	450	300
WIDTH (WW) :	600	450	300
HEIGHT (H) :	100	100	75
RADIUS (R) :	600	600	600

TABLE FOR HORIZONTAL TEE REDUCER :				
WIDTH (W) :	600	600	450	300
WIDTH (WW) :	450	300	600	600
HEIGHT (H) :	100	100	100	100
RADIUS (R) :	600	600	600	600

NOTE :

- 1) FOR NOTES REFER SHEET 20 OF 22.
- 2) CABLE TRAY ACCESSORIES SHALL BE FABRICATED FROM MS / SS SHEET

TITLE: Typical details of Cable Tray & its Accessories along with cable rack assembly.	DRG. NO. : HPE/01	REV. 02
	SH. 8 OF 22	

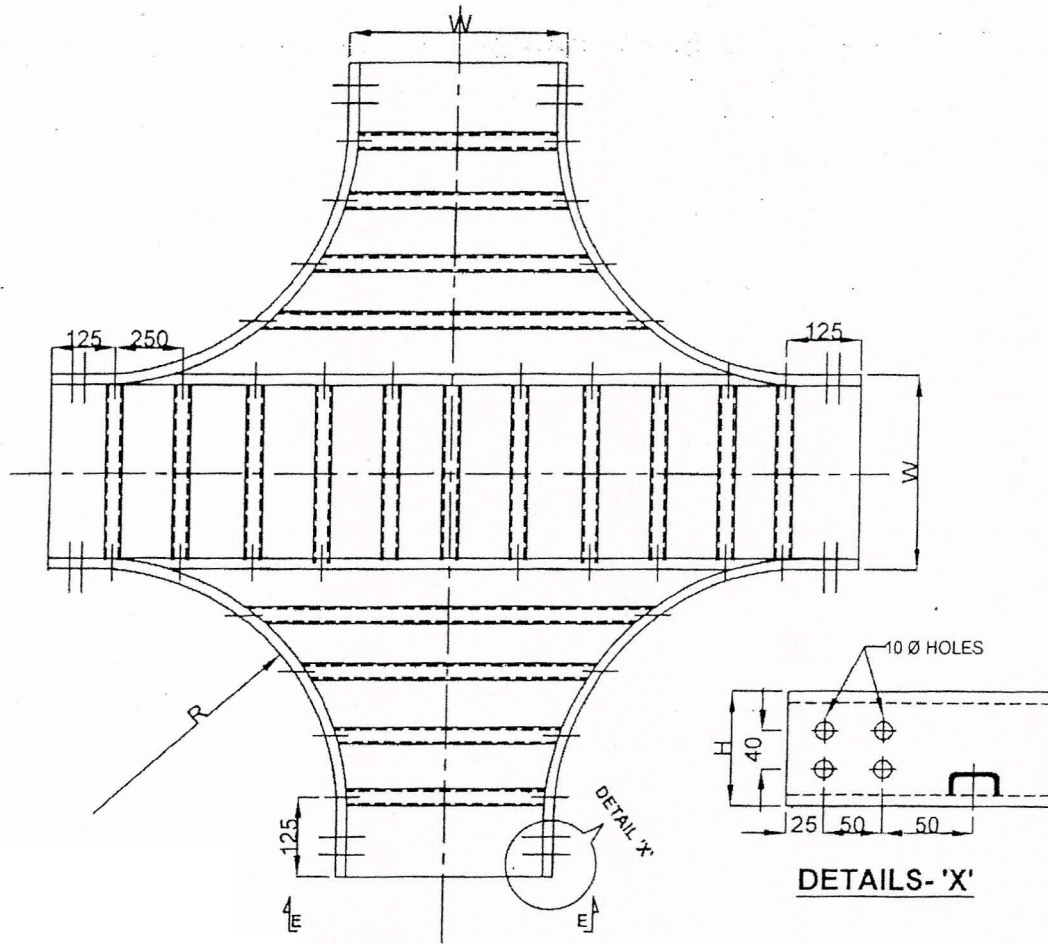

PLAN
30° HORIZONTAL CROSS

TABLE FOR EQUAL CROSS :			
WIDTH (W) :	600	450	300
HEIGHT (H) :	100	100	75
RADIUS (R) :	600	600	600

NOTE :

- 1) FOR NOTES REFER SHEET 20 OF 22.
- 2) CABLE TRAY ACCESSORIES SHALL BE FABRICATED FROM MS / SS SHEET

TITLE:

Typical details of Cable Tray & its Accessories
along with cable rack assembly.

DRG. NO. : HPE/01

REV-02

SH. 9 OF 22

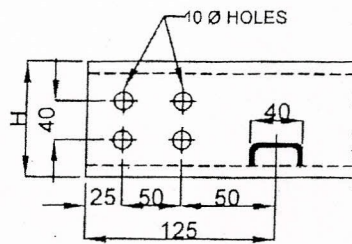
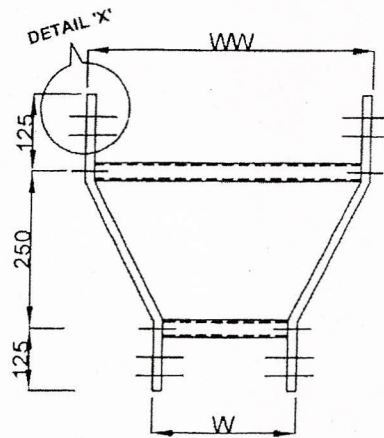

DETAILS- 'X'

**PLAN
REDUCER LADDER TYPE**

TABLE FOR REDUCER :			
WIDTH (WW) :	600	600	450
WIDTH (W) :	450	300	300
HEIGHT (H) :	100	100	100

NOTE :

- 1) FOR NOTES REFER SHEET 20 OF 22.
- 2) CABLE TRAY ACCESSORIES SHALL BE FABRICATED FROM MS / SS SHEET

TITLE:

Typical details of Cable Tray & its Accessories
along with cable rack assembly.

DRG. NO. : HPE/01

REV-02

SH. 10 OF 22

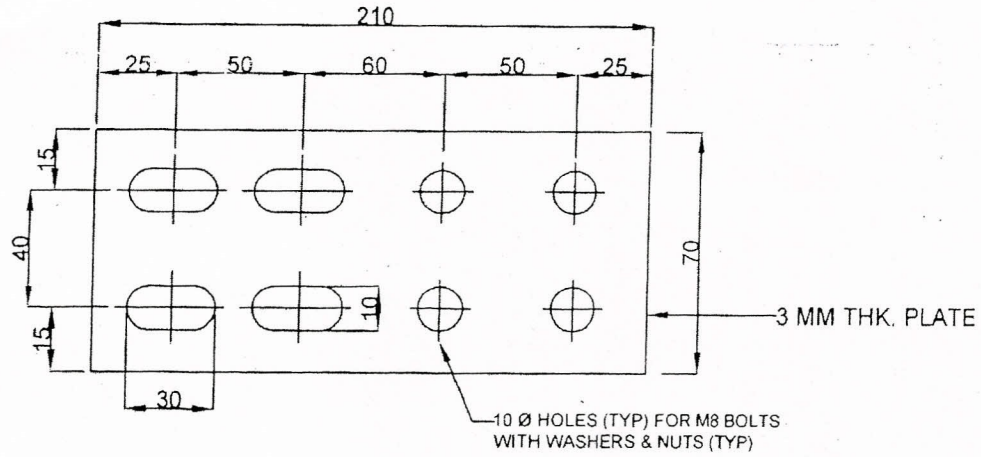

**COUPLER PLATE (CP)
FOR 100 / 75 MM HEIGHT TRAY**

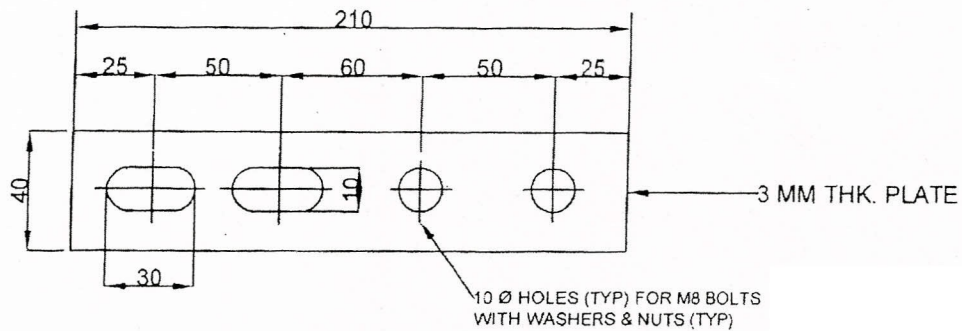

**COUPLER PLATE (CP)
FOR 50 H TRAY (3MM THICK)**

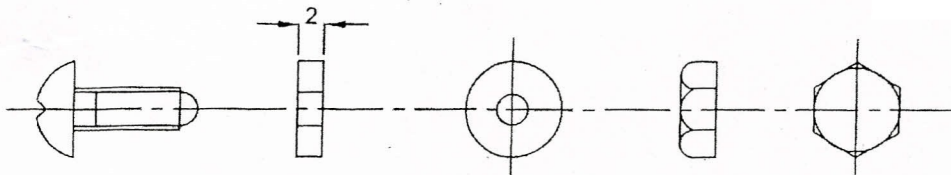

**M8X20 BOLT, WASHER & NUT (FASTNER)
FOR CABLE TRAY JOINT**

NOTE :

- 1) FOR NOTES REFER SHEET 20 OF 22.
- 2) COUPLER PLATES SHALL BE FABRICATED FROM MS / SS SHEET
- 3) 8 NOS. OF FASTNERS SHALL BE SUPPLIED ALONG WITH EACH COUPLER PLATE FOR 100 MM & 75MM HEIGHT CABLE TRAY.
- 4) 4 NOS. OF FASTNERS SHALL BE SUPPLIED ALONG WITH EACH COUPLER PLATE FOR 50 MM HEIGHT CABLE TRAY.

TITLE:

Typical details of Cable Tray & its Accessories
along with cable rack assembly.

DRG. NO. : HPE/01

REV-02

SH. 11 OF 22

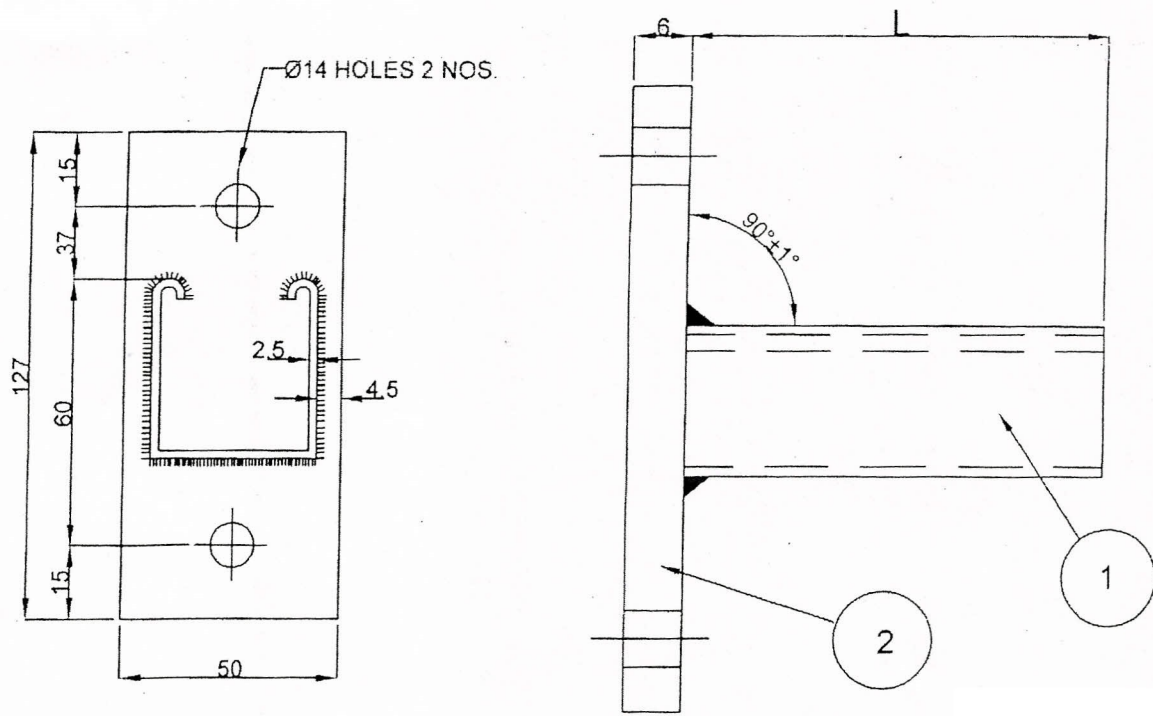

CANTILEVER ARM [MS / SS]

TRAY WIDTH IN MM	CANTILEVER ARM LENGTH (L) IN MM
150	200
300	350
450	500
600	650

NOTE :
 FOR NOTES REFER SHEET 20 OF 22.
 CANTILEVER ARM SHALL BE FABRICATED FROM MS / SS SHEET

TITLE: Typical details of Cable Tray & its Accessories along with cable rack assembly.	DRG. NO. : HPE/01	REV-02
	SH. 12 OF 22	

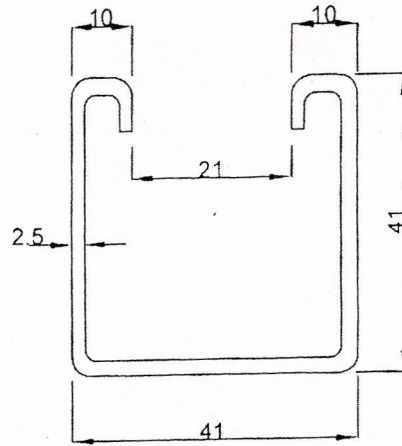
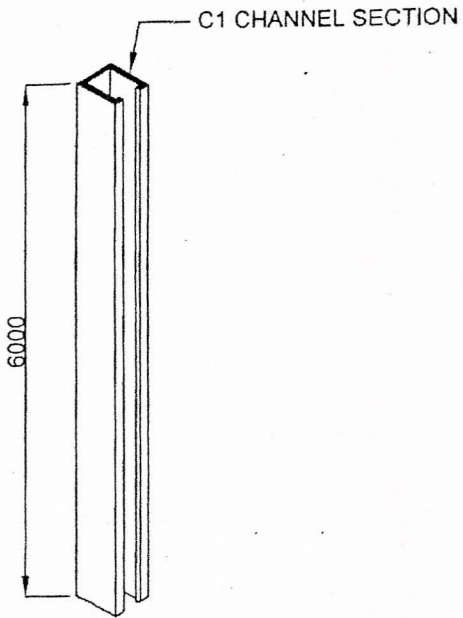

PLAN

SINGLE CHANNEL [C1]

NOTE :

FOR NOTES REFER SHEET 20 OF 22.
 SINGLE CHANNEL SHALL BE FABRICATED FROM MS / SS SHEET

TITLE:

Typical details of Cable Tray & its Accessories
 along with cable rack assembly.

DRG. NO. : HPE/01

REV-02

SH. 13 OF 22

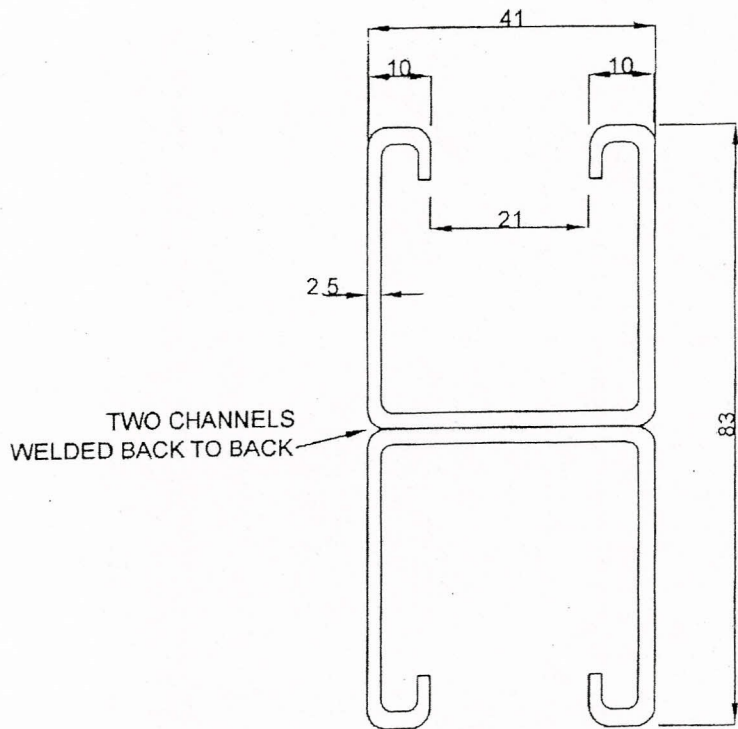
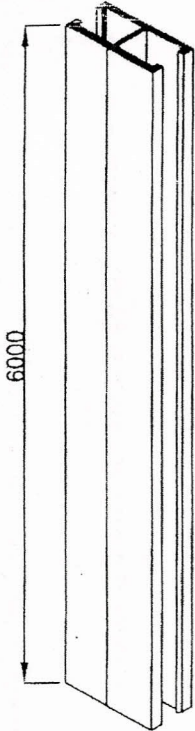

PLAN

DOUBLE CHANNEL [C1]

NOTE :

FOR NOTES REFER SHEET 20 OF 22.
 DOUBLE CHANNEL SHALL BE FABRICATED FROM MS/ SS SHEET

TITLE:

Typical details of Cable Tray & its Accessories
 along with cable rack assembly.

DRG. NO. : HPE/01

REV-02

SH. 14 OF 22

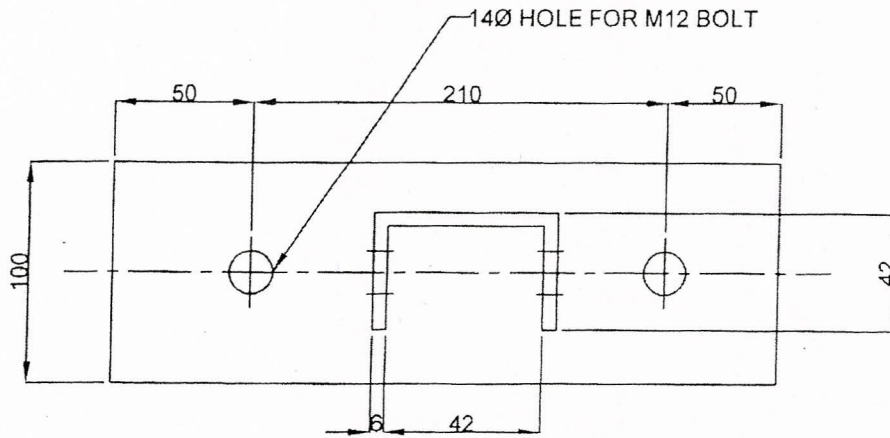
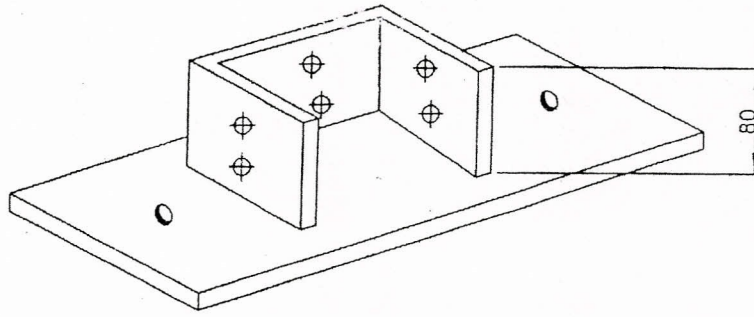

**MOUNTING BASE PLATE
FOR SINGLE CHANNEL**

NOTE :

1. ALL DIMENSIONS ARE IN MM.
2. MATERIAL : M.S / S.S AS PER IS:2062
3. FASTNERS : 2 SETS OF M12X35 SPRING NUTS & 2 SETS OF M12X100 ANCHOR FASTNERS WILL BE SUPPLIED ALONG WITH EACH BASE PLATE.

TITLE:

**Typical details of Cable Tray & its Accessories
along with cable rack assembly.**

DRG. NO. : HPE/01

REV-02

SH. 15 OF 22

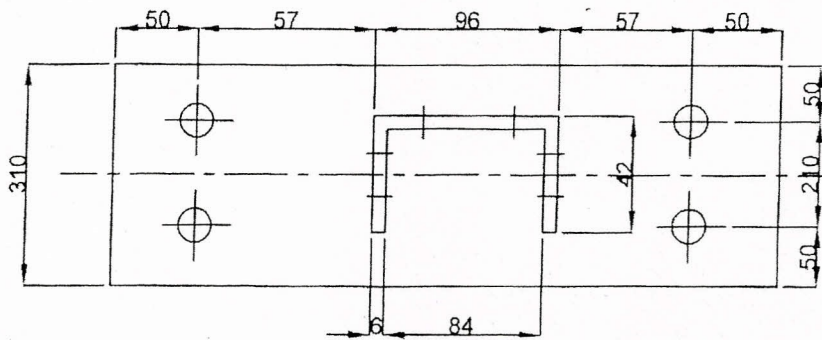
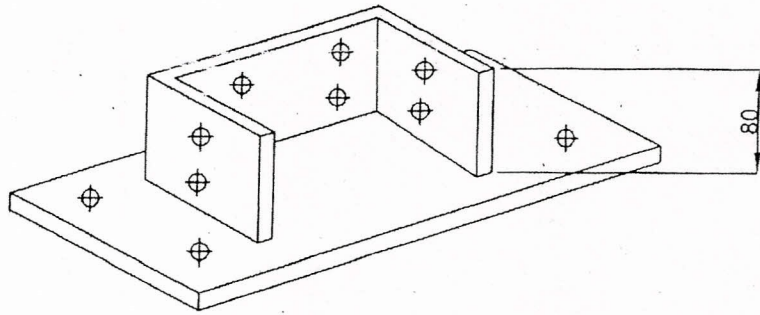

MOUNTING BASE PLATE
FOR DOUBLE CHANNEL

NOTE :

1. ALL DIMENSIONS ARE IN MM.
2. MATERIAL : M.S / S.S AS PER IS:2062
3. FASTNERS : 4 SETS OF M12X35 SPRING NUTS & 4 SETS OF M12X100 ANCHOR FASTNERS WILL BE SUPPLIED ALONG WITH EACH BASE PLATE.

TITLE:

Typical details of Cable Tray & its Accessories
along with cable rack assembly.

DRG. NO. : HPE/01

REV-02

SH. 16 OF 22

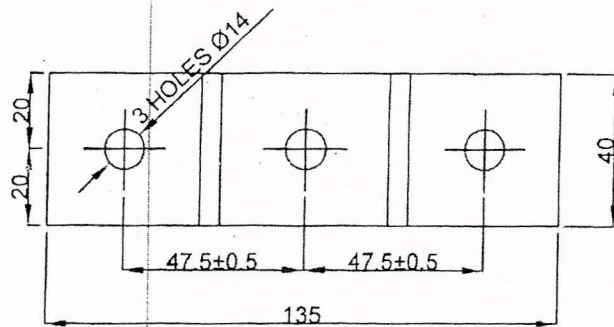
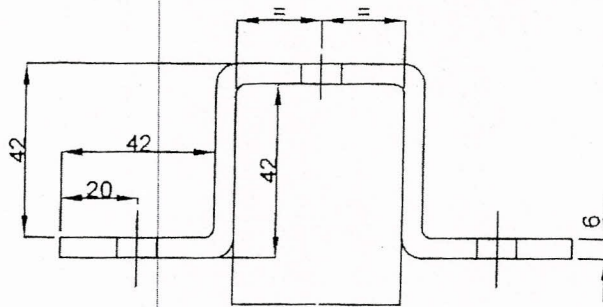
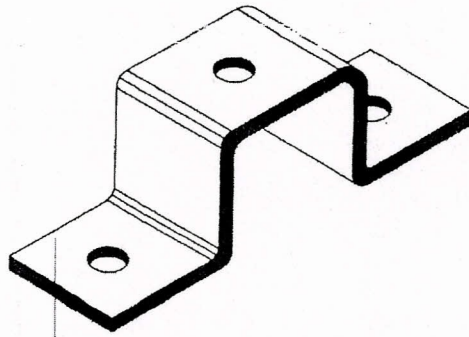

CLAMPS 'CC1'

NOTE :

1. ALL DIMENSIONS ARE IN MM.
2. MATERIAL : M.S / S.S AS PER IS:2062
3. FASTNERS : 1 SET OF M12X35 SPRING NUT & 2 SETS OF M12X100 ANCHOR FASTNERS WILL BE SUPPLIED ALONG WITH EACH CC1 CLAMP.

TITLE:

Typical details of Cable Tray & its Accessories
along with cable rack assembly.

DRG. NO. : HPE/01

REV-02

SH. 17 OF 22

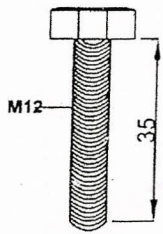
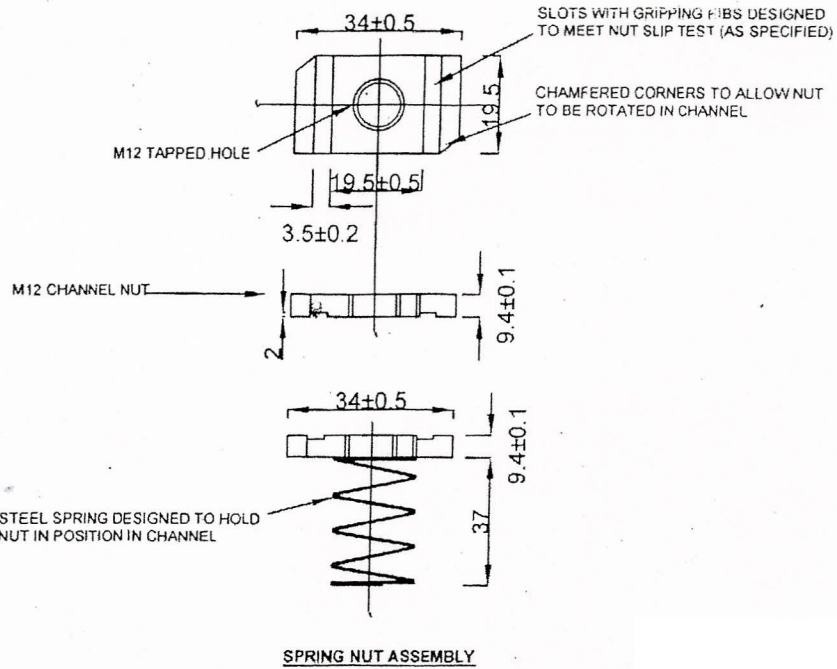

HEX BOLT

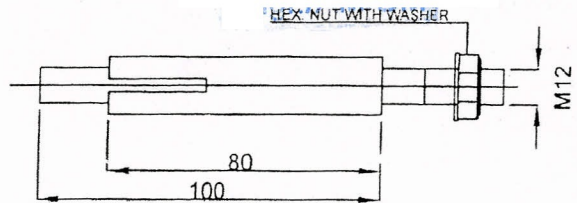

ANCHOR BOLT M12

NOTE :

1. ALL DIMENSIONS ARE IN MM.
2. MATERIAL : M.S / S.S AS PER IS:2062
3. M6 CHANNEL NUT DIMENSION SIMILAR TO M12
EXCEPT HOLE DRILLED AND TAPPED TO M6 PAN HEAD SCREWS.
4. TAPPED HOLE THREADING TO MATCH WITH THREADING OF BOLTS.
5. SURFACE PROTECTION ELECTRO-GALVANIZED / CADMIUM PLATED, 20 MICRONS THICK.
6. BOLTS SHALL BE HOT DIP GALVANIZED.

TITLE:

Typical details of Cable Tray & its Accessories
along with cable rack assembly.

DRG. NO. : HPE/01

REV-02

SH. 18 OF 22

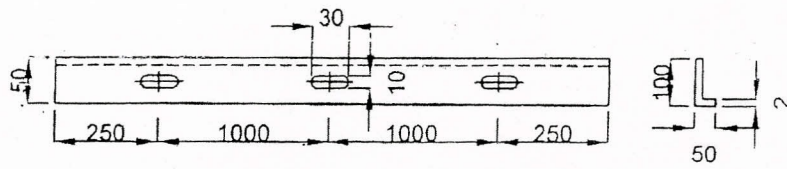

BARRIER STRIP 2500 L X 100 H X 2 T

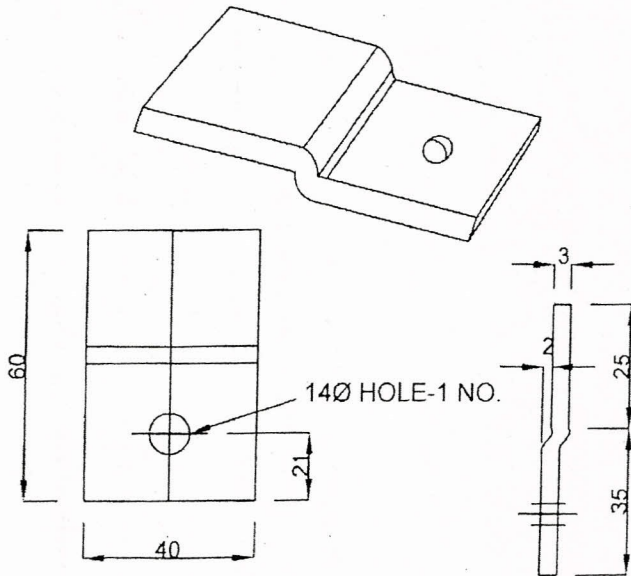

TRAY FIXING CLAMP FOR LADDER TYPE TRAY

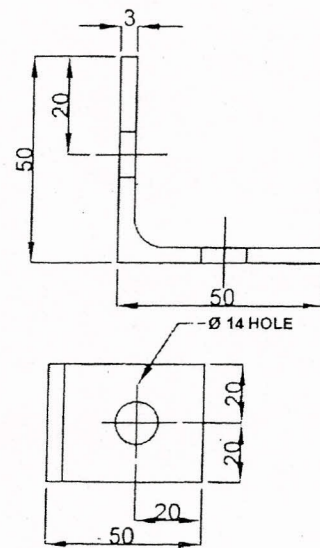

TRAY FIXING CLAMP FOR PERFORATED TYPE TRAY

NOTES ::

- 1) ALL DIMENSION ARE IN MM UNLESS & OTHERWISE STATED.
- 2) STEEL TO CONFIRM AS PER IS: 2062 (GR.A)
- 3) FASTNERS : 1 SET OF M12 SPRING NUT SHALL BE SUPPLIED ALONG WITH EACH TRAY FIXING CLAMP (BOTH LADDER & PERFORATED TYPE CABLE TRAY).

<p>TITLE:</p> <p>Typical details of Cable Tray & its Accessories along with cable rack assembly.</p>	<p>DRG. NO. : HPE/01</p>	<p>REV-02</p>
	<p>SH. 19 OF 22</p>	

NOTE ::

- 1) ALL DIMENSIONS ARE IN MM UNLESS OTHERWISE STATED.
- 2) CABLE TRAYS & ACCESSORIES SHALL BE FABRICATED FROM 14 SWG THICK M.S / S.S SHEET AND COUPLER PLATES SHALL BE FABRICATED FROM 3MM THICK MS SHEET CONFORMING TO IS:1079 GR. 'O' / IS:2062.
- 3) BOLTABLE TYPE TRAY SUPPORT SHALL BE FABRICATED FROM 2.5MM THICK MS SHEET CONFORMING TO IS:1079 GR. 'O' / IS:2062.
- 4) TOLERANCE ON THICKNESS ± 0.2 MM AS PER IS:1852.
- 5) PERFORATED TYPE CABLE TRAYS SHALL BE FABRICATED FROM SINGLE M.S / S.S SHEET.
- 6) SUITABLE RUNG SPACING TO BE CONSIDERED FOR LADDER TYPE TRAY & ACCESSORIES DEPENDING ON THE JOB.
- 7) SIDE CHANNEL OF PERFORATED TRAY ACCESSORIES SHALL BE WELDED WITH THE PERFORATED SHEET AT A INTERVAL OF MAX. 100MM. LENGTH OF WELDING SHALL BE NOT LESS THAN 25MM.
- 8) TO FACILITATE ASSEMBLY, ALL ACCESSORIES AT ENDS SHALL HAVE 100MM STRAIGHT PORTION.
- 9) CABLE TRAYS, RACK ASSEMBLY, TRAY ACCESSORIES AND COUPLER PLATES SHALL BE HOT DIP GALVANIZED AS PER IS:2629.
- 10) ALL NUT, BOLT & WASHERS ABOVE M10 SHALL BE HOT DIP GALVANIZED. FOR SIZE BELOW M10, SAME SHALL BE ZINC PASSIVATED (8 MICRONS).
- 11) MASS OF ZINC COATING SHALL BE AS PER IS:4759.

TITLE:

Typical details of Cable Tray & its Accessories
along with cable rack assembly.

DRG. NO. : HPE/01

REV-02

SH. 20 OF 22

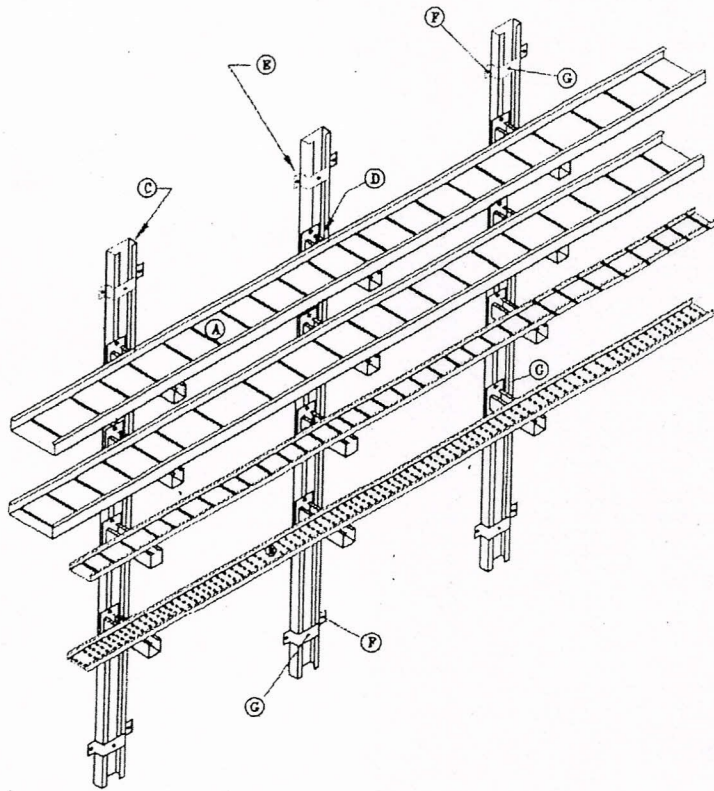

NOTE :

1. 'A' : LADDER TYPE CABLE TRAY (REFER SHEET NO. 6 OF 22).
2. 'B' : PERFORATED TYPE CABLE TRAY (REFER SHEET NO. 1 OF 22).
3. 'C' : C1 CHANNEL (REFER SHEET NO. 13 OF 22)
4. 'D' : CANTILEVER ARM (REFER SHEET NO. 12 OF 22).
5. 'E' : CC1 CLAMP (REFER SHEET NO. 17 OF 22).
6. 'F' : ANCHOR BOLT (REFER SHEET NO. 18 OF 22).
7. 'G' : SPRING NUT (REFER SHEET NO. 18 OF 22).

ASSEMBLY DRAWING SHOWING FIXING ARRANGEMENT OF SINGLE CHANNEL WITH CC1 CLAMP, CANTILEVER ARM WITH SINGLE CHANNEL AND CABLE TRAY WITH CANTILEVERS ARMS THROUGH DIFFERENT TYPES OF HARDWARES. LIKE ANCHOR BOL & SPRING NUTT.

TITLE:

Typical details of Cable Tray & its Accessories
along with cable rack assembly.

DRG. NO. : HPE/01

REV-02

SH. 21 OF 22

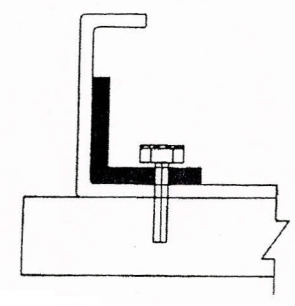
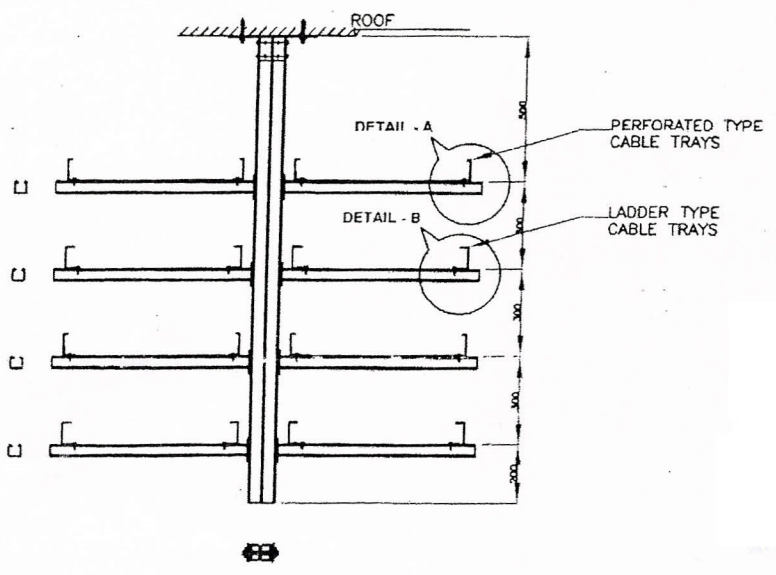
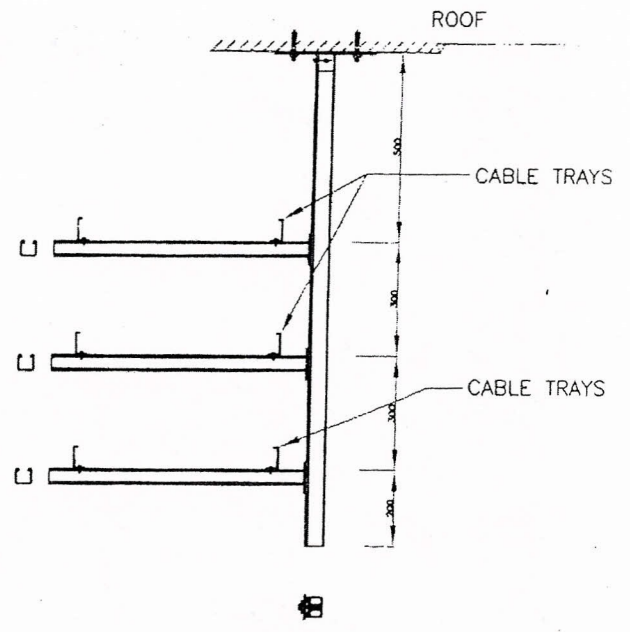
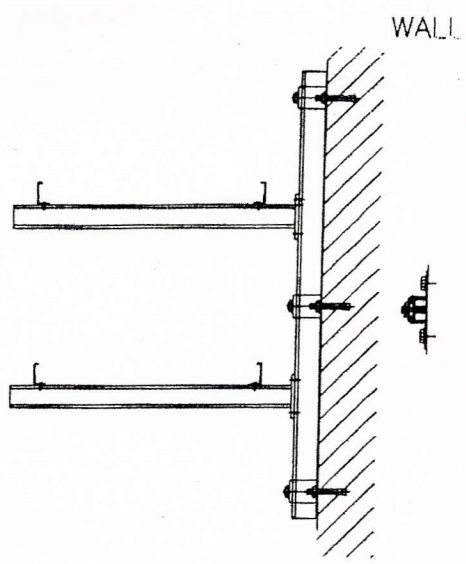

DETAIL - A

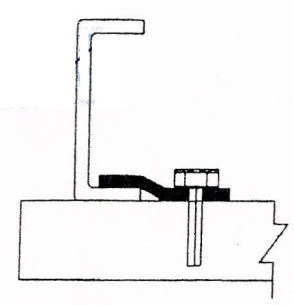

DETAIL - B

TITLE:
 Typical details of Cable Tray & its Accessories
 along with cable rack assembly.

DRG. NO. : HPE/01

REV-02

SH. 22 OF 22