

Techno-Commercial Bid Annexure to Enquiry No.1213-042 Dated 15.06.2012, Due date 11.07.2012

Enq Sl. No.	Code	Description of material	Material Specification	Drawing No.	TDC No.	Enquiry Qty (Nos.)	Quoted	Unit Basic Price, Rs. per pc.
1	922030490000	Forged Wedge 2-C150/300-GV	SA105	3-V-0000-25109F	404/09	2500	Yes/No	"Pl. see price bid"
2	922030500000	Forged Wedge 3-C150-GV		3-V-0000-25110F		3400	Yes/No	"Pl. see price bid"
3	922030370000	Forged Wedge 3-C300-GV		3-V-0000-25098F		1200	Yes/No	"Pl. see price bid"
4	922030480000	Forged Wedge 4-C150-GV		2-V-0000-14755F		1800	Yes/No	"Pl. see price bid"
5	922030470000	Forged Wedge 4-C300-GV		2-V-0000-14754F		1000	Yes/No	"Pl. see price bid"
Excise Duty rate (mention in % if applicable, mention as <b>NIL</b> if not applicable)					Applicable/Not applicable			
					Extra/Inclusive			
					% if applicable		<i>Pl. clearly mention in % if applicable</i>	
Cess on ED rate (mention in % if applicable)								
CST (%) / VAT (%)					Extra/Inclusive			
					%			
Validity of offers ( <b>As per BHEL terms 60 days validity is required</b> )							<i>Pl. clearly mention</i>	
The above prices are <b>Firm, without any price escalation; are Rs. per piece; and are on FOR Goindwal Sahib basis.</b>								
We accept all terms and conditions of the Tender Enquiry No. 1213-042 dated 15.06.2012								
Authorised signatory with seal								

Techno-Commercial Bid Annexure to Enquiry No.1213-042 Dated 15.06.2012, Due date 11.07.2012

Enq Sl. No.	Code	Description of material	Material Specification	Drawing No.	TDC No.	Enquiry Qty (Nos.)	Unit Basic Price, Rs. per pc.
1	922030490000	Forged Wedge 2-C150/300-GV	SA105	3-V-0000-25109F	404/09	2500	"To be filled by the vendor"
2	922030500000	Forged Wedge 3-C150-GV		3-V-0000-25110F		3400	"To be filled by the vendor"
3	922030370000	Forged Wedge 3-C300-GV		3-V-0000-25098F		1200	"To be filled by the vendor"
4	922030480000	Forged Wedge 4-C150-GV		2-V-0000-14755F		1800	"To be filled by the vendor"
5	922030470000	Forged Wedge 4-C300-GV		2-V-0000-14754F		1000	"To be filled by the vendor"

Authorised signatory with seal



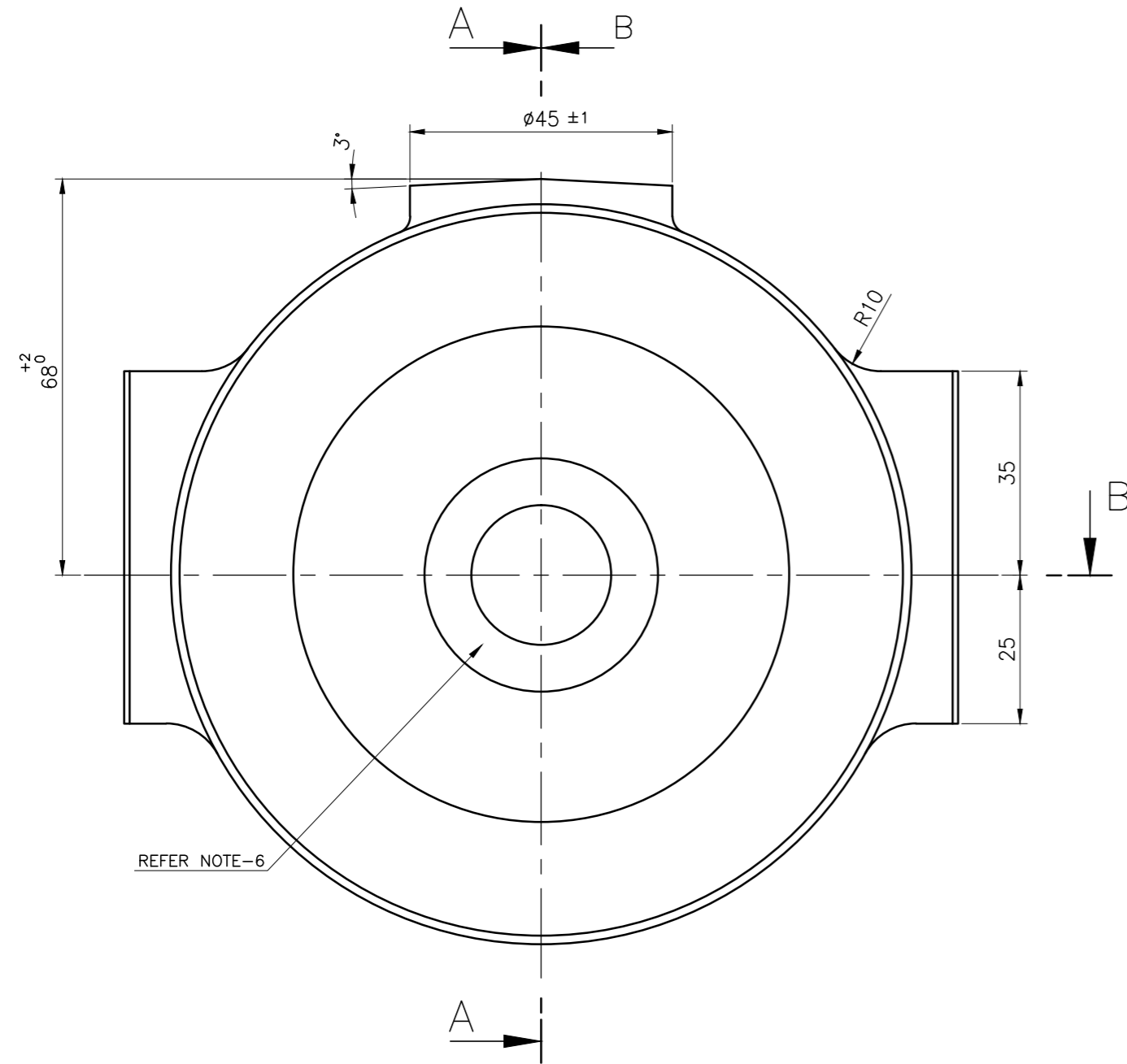

REFER NOTE-6

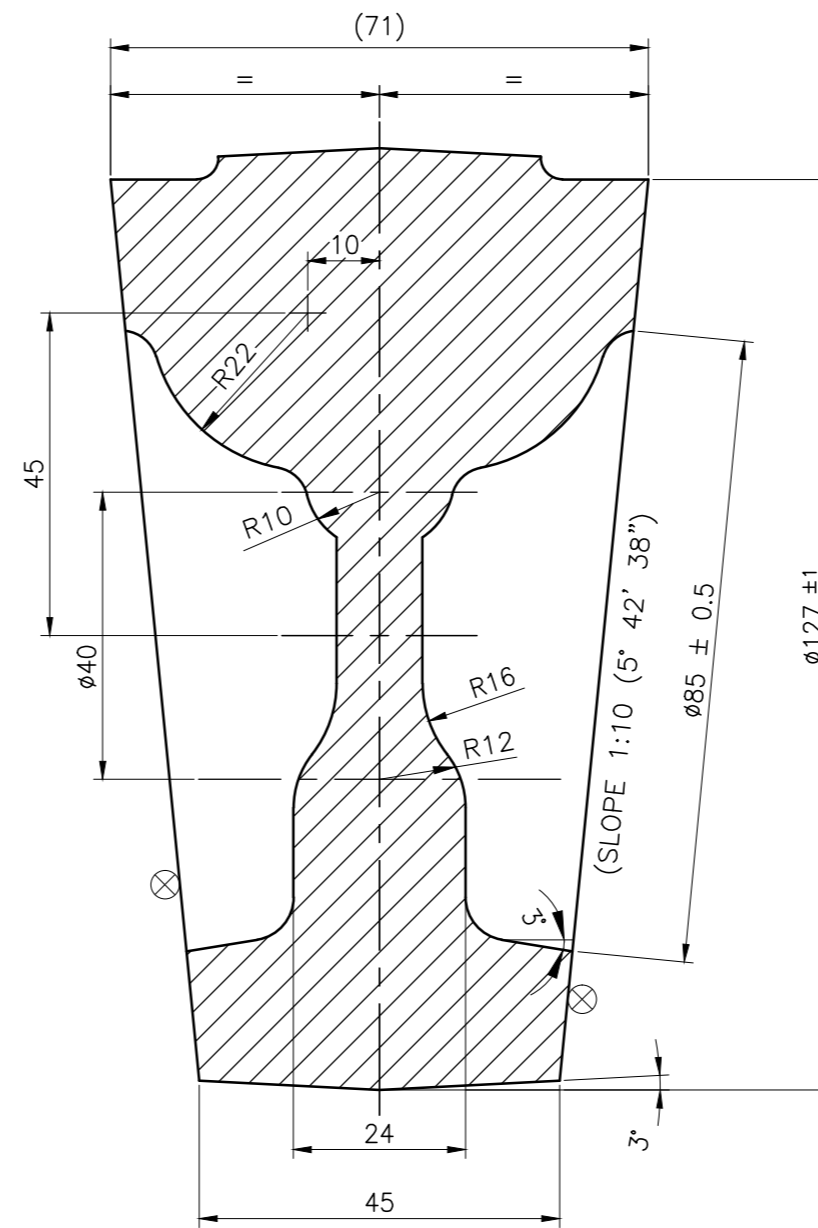

SECTION-AA

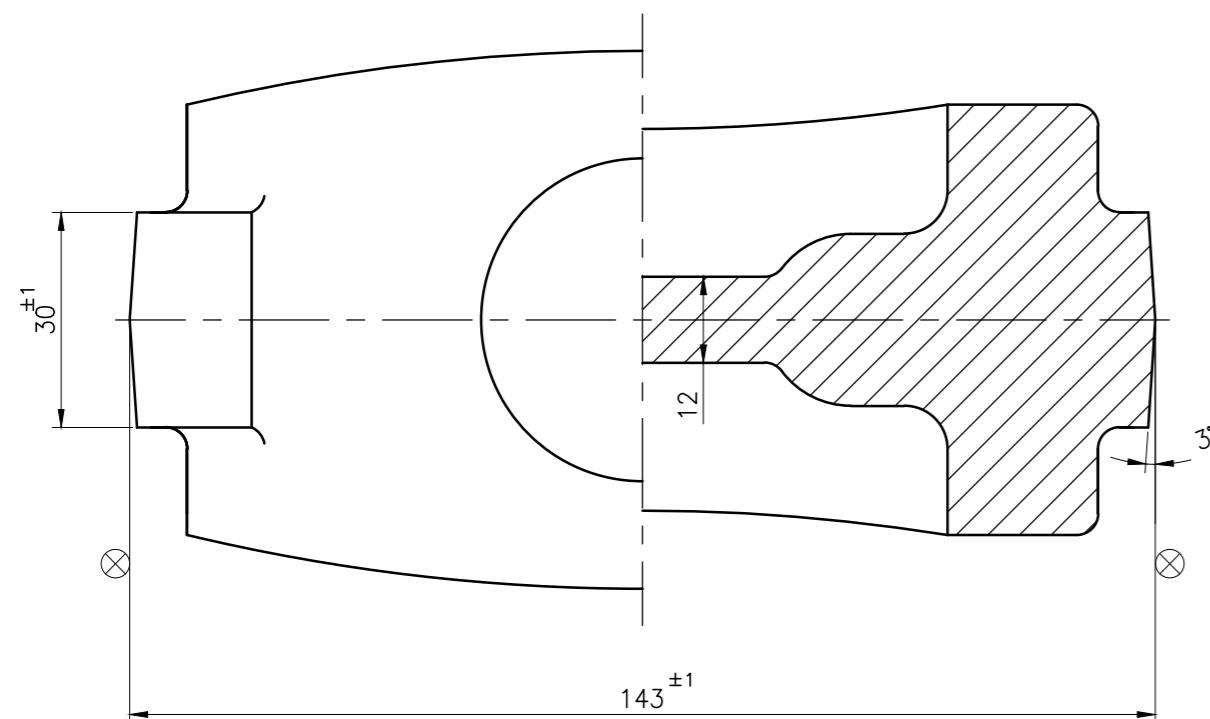

SECTION-BB

NOTES:

- ⊗ INDICATES THE SURFACES WHICH ARE TO BE MACHINED FURTHER.
- FORGINGS SHALL COMPLY WITH REQUIREMENTS OF LATEST APPLICABLE QUALITY PROCEDURES.
- FORGE DRAFT MAX. 7°.
- UNSPECIFIED FORGING RADII R3 (MAX).
- FORGINGS SHALL BE SAND BLASTED OR SHOT BLASTED AND HEAT TREATED AS SPECIFIED.
- THE FOLLOWING IDENTIFICATION MARKING TO BE PUNCHED IN THE ZONE SPECIFIED IN THE DRG (TO BE MADE WITHIN THE CIRCLE DIA 60MM SHOWN)  
4"-150C  
MATERIAL CODE  
SUPPLIER CODE  
HEAT NO

SL No.	DESCRIPTION	MATL CODE	MATL SPECN	HEAT TREATMENT	SCRAP SORT	NET WT (kg)	GROSS WT (kg)	DRAWING No	ITEM No
		922030480000	SA 105 CERTIFY	NORMALISED				2-V-N203-14755F	

TYPE OF PRODUCT OR NAME OF CUSTOMER/PROJECT: **CS**

	<b>BHARAT HEAVY ELECTRICALS LTD.,</b> UNIT: HIGH PRESSURE BOILER PLANT. TIRUCHIRAPALLI - 620014		DRN	ARUNKUMAR P	SIGN	DATE	NO.OF VAR.
	CHD	S. SATHEES				24.04.12	
	APPD	M. RAJAKUMAR				24.04.12	

DEPT	VL	SCALE	WEIGHT (KG)	REFERENCE INFORMATION	NO. OF ITEMS
320		NTS	5.20		
TITLE	CARD CODE	DRAWING NO.	REV		
WEDGE (4"-150C)	U 01	2-V-0000-14755F	00		

CAUTION: The information on this document is the property of BHARAT HEAVY ELECTRICALS LTD. It must not be used directly or indirectly in any way detrimental to the interest of the company.

REV	DATE	ALTERED
		CHD & APPD
ZONE		

DRAWING NO. 3-V-0000-25098F

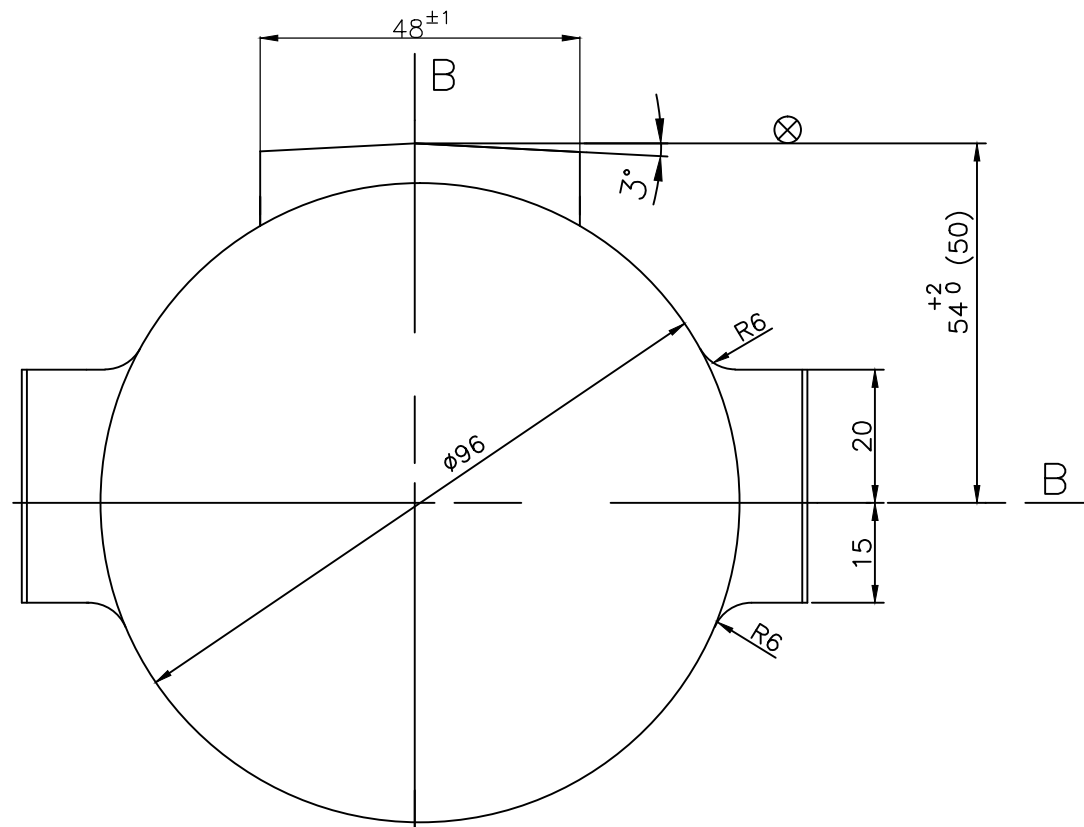

SECTION-BB

SECTION-AA  
(83)

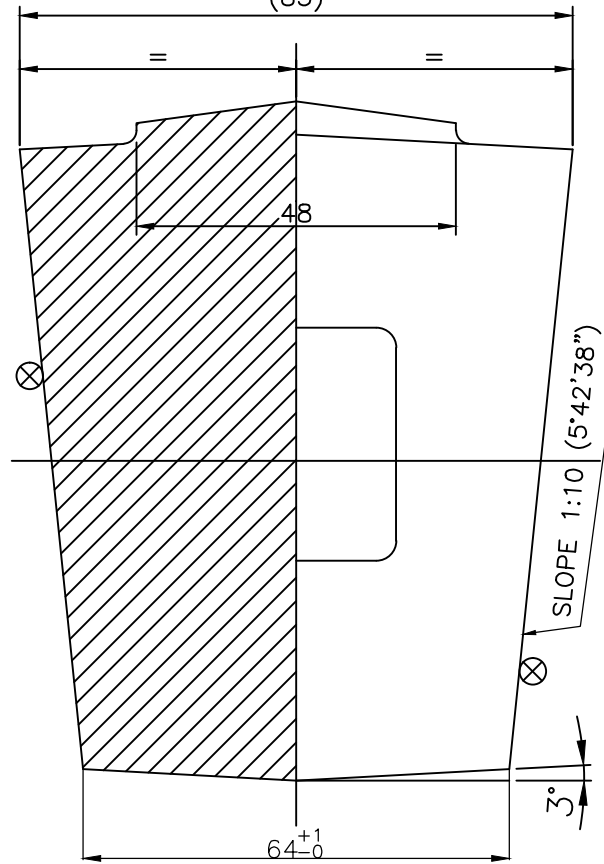

NOTES:

- ⊗ INDICATES THE SURFACES WHICH ARE TO BE MACHINED FURTHER.
- FORGINGS SHALL COMPLY WITH REQUIREMENTS OF LATEST APPLICABLE QUALITY PROCEDURE.

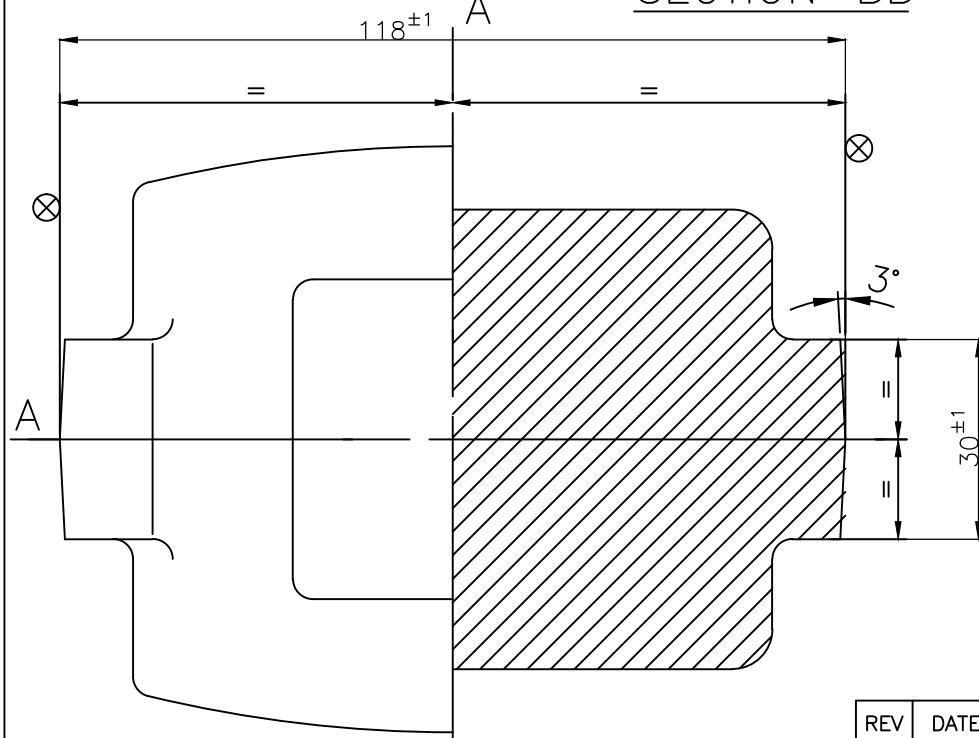

REV	DATE	ALTERED
		CHD & APPD

CAUTION: The information on this document is the property of BHARAT HEAVY ELECTRICALS LTD. It must not be used directly or indirectly in any way detrimental to the interest of the company.

		922030370000	SA 105, CERTIFY	NORMALISED					3.V.N209.25098F
NO OFF	DESCRIPTION	MATL CODE	MATL SPECN	HEAT TREATMENT	SCRAP SORT	NET WT (kg)	GROSS WT (kg)	DRAWING No	ITEM No
	TYPE OF PRODUCT OR NAME OF CUSTOMER/PROJECT	CS							
	BHARAT HEAVY ELECTRICALS LTD. UNIT: HIGH PRESSURE BOILER PLANT. TIRUCHIRAPALLI - 620014.	DRN	R.GANGA	SIGN		DATE	09.01.12	NO.OF VAR.	
		CHD	S.SATHEES			DATE	09.01.12		
		APPD	M.RAJAKUMAR			DATE	09.01.12		
DEPT VL	SCALE	WEIGHT (KG).	REFERENCE INFORMATION		NO. OF ITEMS				
CODE 320	NTS	4.3	CAD:C325098F						
TITLE	WEDGE (3"-300C)	CARD CODE	DRAWING NO.		REV				
		U 01	3-V-0000-25098F		00				

DRAWING NO. 3-V-0000-25109F

ALL DIMENSIONS ARE IN MILLIMETRES. FOR TOLERANCES OF UNTOLERANCED DIMENSIONS DURING MANUFACTURE REFER RELEVANT QCP / QP.

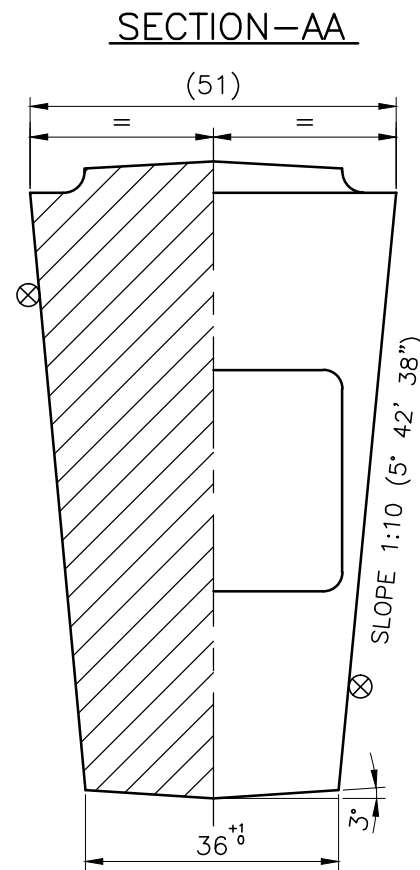
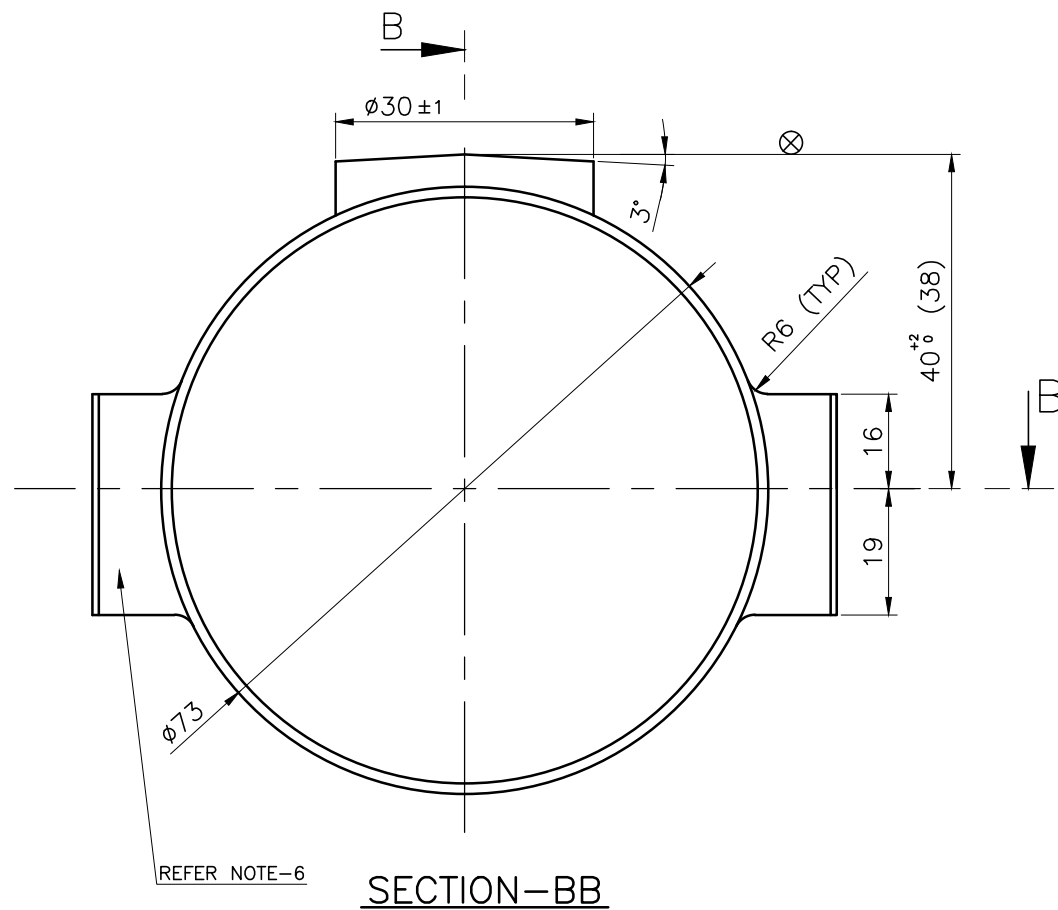

**NOTES:**

- ⊗ INDICATES THE SURFACES WHICH ARE TO BE MACHINED FURTHER.
- FORGINGS SHALL COMPLY WITH REQUIREMENTS OF LATEST APPLICABLE QUALITY PROCEDURES.
- FORGE DRAFT MAX. 7°.
- UNSPECIFIED FORGING RADII R3 (MAX).
- FORGINGS SHALL BE SAND BLASTED OR SHOT BLASTED AND HEAT TREATED AS SPECIFIED.
- THE FOLLOWING IDENTIFICATION MARKING TO BE PUNCHED IN THE ZONE SPECIFIED IN THE DRG  
 2"-150C/300C  
 MATERIAL CODE  
 SUPPLIER CODE  
 HEAT NO

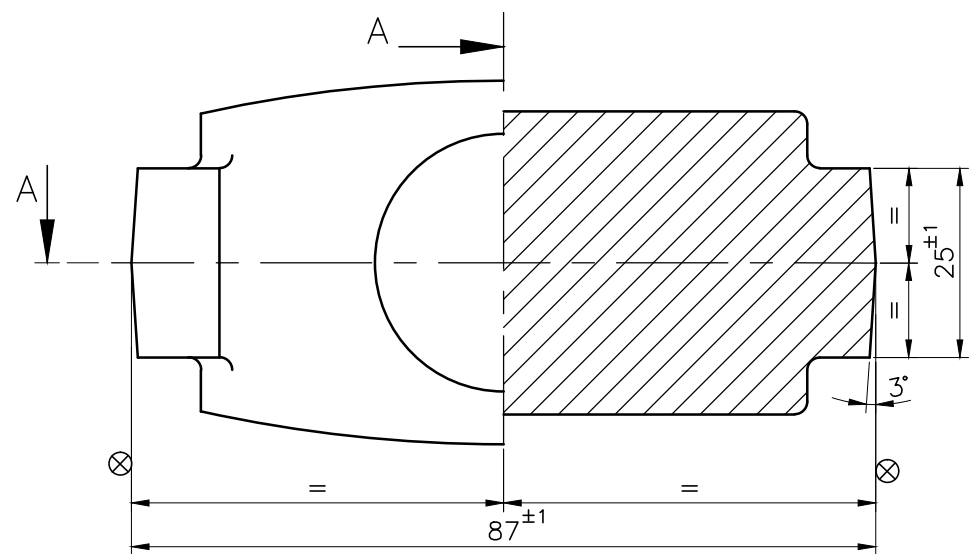

REFER NOTE-6

**SECTION-BB**

REV	DATE	ALTERED
		CHD & APPD

CAUTION: The information on this document is the property of BHARAT HEAVY ELECTRICALS LTD. It must not be used directly or indirectly in any way detrimental to the interest of the company.

		922030490000	SA 105 CERTIFY	NORMALISED				3-V-N201-25109F	
N.O. OFF	DESCRIPTION	MATL CODE	MATL SPECN	HEAT TREATMENT	SCRAP SORT	NET WT (kg)	GROSS WT (kg)	DRAWING No	ITEM No
TYPE OF PRODUCT OR NAME OF CUSTOMER/PROJECT									
<b>BHARAT HEAVY ELECTRICALS LTD.</b> UNIT: INDUSTRIAL VALVES PLANT. GOINDWAL SAHIB - 143422					DRN	NAME	SIGN	DATE	NO.OF VAR.
365-121					CHD	S. SATHEES		24.04.12	
					APPD	M. RAJAKUMAR		24.04.12	
DEPT	CODE	SCALE		WEIGHT (KG).	REFERENCE INFORMATION				NO. OF ITEMS
		NTS		1.75					
TITLE						CARD CODE	DRAWING NO.		REV
WEDGE (2"-150C/300C)						U 01	3-V-0000-25109F		00

DRAWING NO. 3-V-0000-25110F

ALL DIMENSIONS ARE IN MILLIMETRES. FOR TOLERANCES OF UNTOLERANCED DIMENSIONS DURING MANUFACTURE REFER RELEVANT QCP / QP.

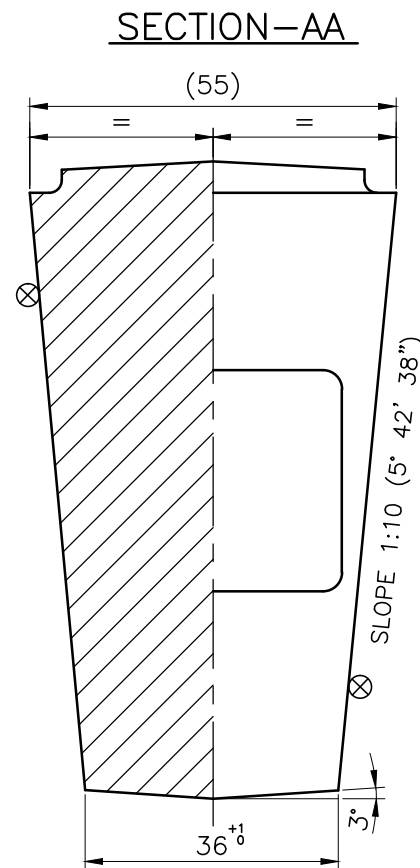
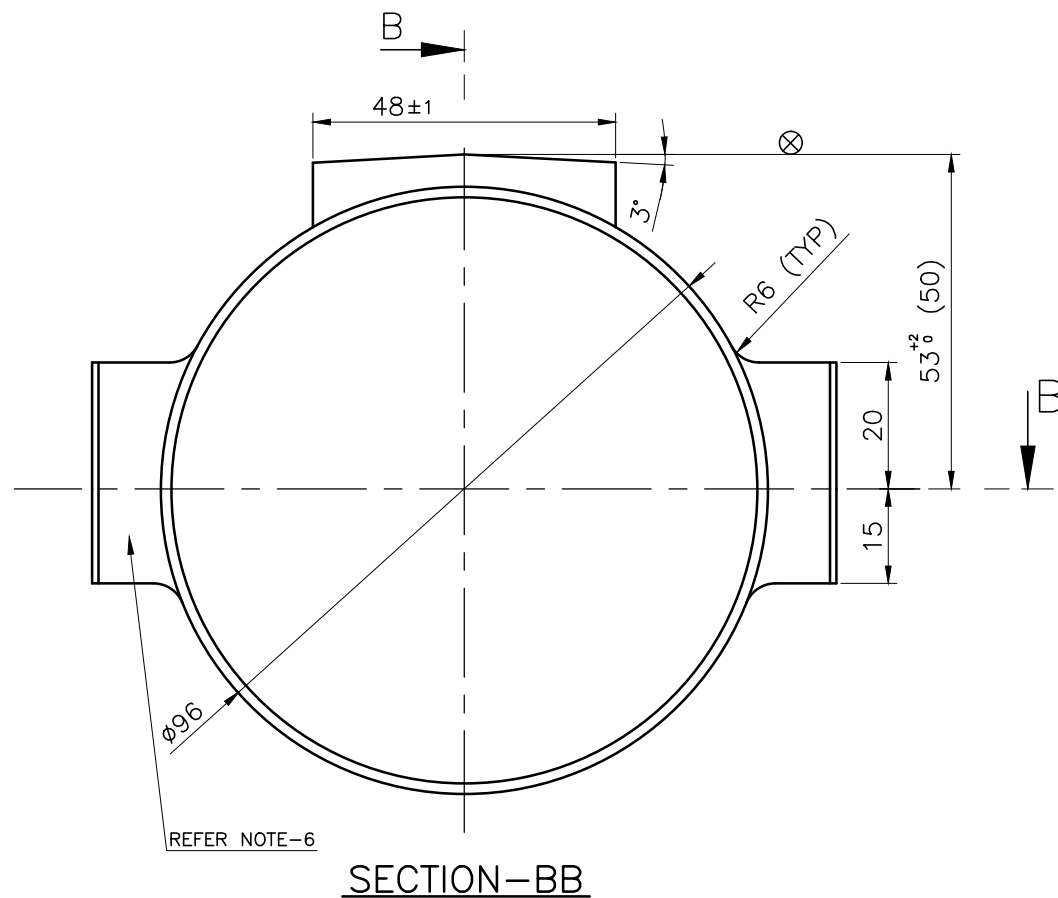

**NOTES:**

1. ⊗ INDICATES THE SURFACES WHICH ARE TO BE MACHINED FURTHER.
2. FORGINGS SHALL COMPLY WITH REQUIREMENTS OF LATEST APPLICABLE QUALITY PROCEDURES.
3. FORGE DRAFT MAX. 7°.
4. UNSPECIFIED FORGING RADII R3 (MAX).
5. FORGINGS SHALL BE SAND BLASTED OR SHOT BLASTED AND HEAT TREATED AS SPECIFIED.
6. THE FOLLOWING IDENTIFICATION MARKING TO BE PUNCHED IN THE ZONE SPECIFIED IN THE DRG  
 3"-150C  
 MATERIAL CODE  
 SUPPLIER CODE  
 HEAT NO

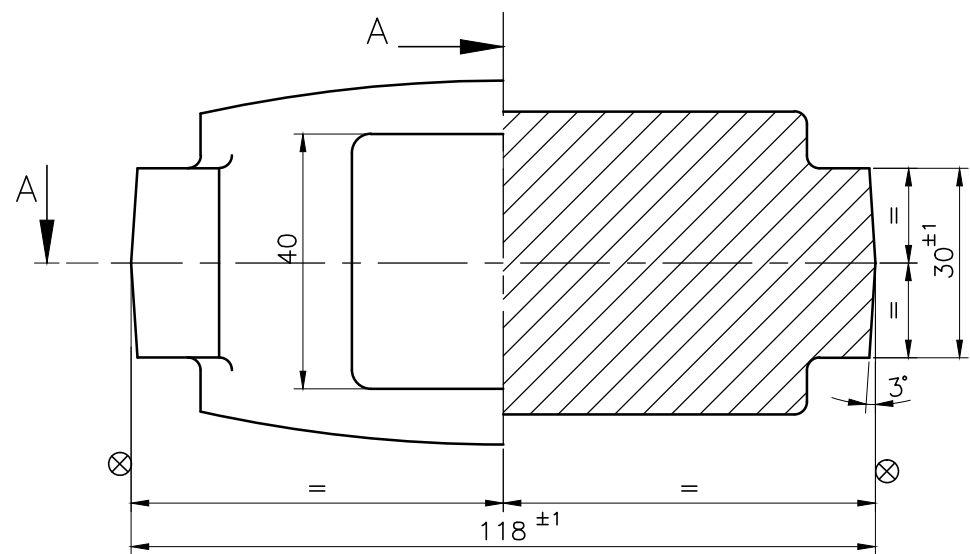

REV	DATE	ALTERED
		CHD & APPD

CAUTION: The information on this document is the property of BHARAT HEAVY ELECTRICALS LTD. It must not be used directly or indirectly in any way detrimental to the interest of the company.

		922030500000	SA 105 CERTIFY	NORMALISED				3-V-N202-25110F	
N.O. OFF	DESCRIPTION	MATL CODE	MATL SPECN	HEAT TREATMENT	SCRAP SORT	NET WT (kg)	GROSS WT (kg)	DRAWING No	ITEM No
TYPE OF PRODUCT OR NAME OF CUSTOMER/PROJECT									
		<b>BHARAT HEAVY ELECTRICALS LTD.</b> UNIT: INDUSTRIAL VALVES PLANT. GOINDWAL SAHIB - 143422			DRN	NAME	SIGN	DATE	NO.OF VAR.
365-121					CHD	S. SATHEES		24.04.12	
					APPD	M. RAJAKUMAR		24.04.12	
DEPT	CODE	SCALE	WEIGHT (KG).	REFERENCE INFORMATION				NO. OF ITEMS	
		NTS	2.75						
TITLE						CARD CODE	DRAWING NO.		REV
WEDGE (3"-150C)						U 01	3-V-0000-25110F		00

**Product: Carbon, Alloy & Stainless Steel Forgings (Boilers And Valves)**

Document No.: TDC:0:404

Rev. No.: 09

Effective date: 23/02/2010

Page 1 of 2

Revision Record: Rev:07:AISI 410 forgings added consequent to material rationalization by Engg.Valves.Rev:08:Cl.2.0 modified for clarity. Cl.5.0 modified to include impact test for CS QCNRV & CRHNRV Valves.Cl.6.0 modified for clarity in UT.Rev:09;New materials F23,F92 added in Cl:1.0,Cl:2.0,Cl:4.0 to Cl:6.0.CE marking certification clarity included in Cl:10.0 .

**1.0 MATERIAL:**

Specification: ASME{Latest on date of Purchase Order (PO)}:

(ASTM also applicable for non pressure parts / Valves)

CARBON STEEL:(CS) : SA 105, SA 350 LF 2

ALLOY STEEL: (AS) : SA 182 F6a Class 3, F12 Class 2, F22 Class 3,

SA 182 F23 (Code Case:2179),SA 182 F91 & F92 (Code Case:2199)

STAINLESS STEEL: (SS) : SA 182 Gr. F 304, 304L, 316, 316L, 316H, 321, 321H, 347 & 347H

AISI 410 for TOA Gland and bushings.

Additional Requirement: As listed below (supplementary to Specification)

Size and Qty.: As per Purchase order & Drawing.

**2.0 CHEMICAL COMPOSITION & PROCESS:**

- Melting: fully killed. Product analysis per heat:

CS: C<=0.25%. AS: SA182 P23: Si:0.25-0.50% & Cu:0.25 max .

SA182 P92: Si:0.10-0.50%; Ni:0.30max & Cu:0.25max

- Steel for forging for IBR items to be inspected at Mill & test certificate countersigned by IBR approved Authority, if the mill is not approved under IBR as well known steel maker.
- Steel for IBR items of SA 182 F12, F22 from indigenous mills to be from following manufacturers approved under IBR for creep resistant steels: (I) Alloy Steel Plant, Durgapur,(ii) Tata Iron & Steel Company, Jamshedpur & (iii) Mahindra UGINE Steel Company, Bombay.(iv) M/S Mukund Limited Karnataka, (v) M/S Kalyani Steels Karnataka.(vi) Remi Metals Gujarat Limited. Gujarat (vii) ISMT Pune.Steel for IBR items of SS and AS other than above shall be imported.
- Forging: to ensure uniformity of structure & strength with reduction ratio in area:1:4min.from ingot to final forging, close to final size & shape. Flow lines to be parallel to axis of openings.
- Blooms / Billets used for forgings (Dia>= 50mm) shall be UT tested. For Acceptance Norm refer Cl.6.0. For finished bars this can be done at final stage.

**3.0 DIMENSIONS AND TOLERANCES:**

Tolerances as per Drawing. Untoleranced dimensions for valve components: VL:STDC:023(latest).

**4.0 HEAT TREATMENT(HT):**

CS: SA 105: Normalised, SA 350 LF 2: Normalised at 880-900 °C & Tempered at 620-640 °C

AS: Normalised and Tempered. For SA182 F91, F92, F23 :Normalizing Temperature: 1050-1080°C

Tempering Temperature: 750°C-780°C. Soaking:1 Hour minimum. Still Air Cooling

AISI 410:Supply in Quenched &Tempered condition as below. Quenching at 955-1010°C in air or water or oil or Polymer.Soaking 30 mts/inch maximum thickness. Tempering at 663°C.min.Soaking :60 mts/inch maximum thickness and Air cool.

**5.0 MECHANICAL TESTS:**

- Extent of test: for each size/heat/HT batch from sample product or identical test coupon.
- Additional requirements for SA182 F91,F92 and F23:  
F91: Yield Strength:(0.2% offset):450MPa min. Tensile Strength: Min:630 MPa,Max:850MPa  
Hardness(HB):Min:191.Max:250  
F92- Tensile Strength:Min:655 MPa, Max:850 MPa. Hardness(HB):Min:196.Max:250  
F23- Tensile Strength: Min:510 MPa, Max:730 MPa. Hardness(HB):Min:150.Max:220
- AISI 410:Hardness 197-235 BHN. No other mechanical test required.
- Additional requirements of tests: (Other than AISI 410 Only.)
- Bend test: Carbon Steel:1 Sample 19mm.Thick(t) x 25.4mm width to be bent 180 deg. around mandrel of radius 6.35 mm. Alloy Steel: Sample 25.4mm width to be bent 180 deg. Around mandrel of radius =1.5 x t.
- Impact test for QCNR Valves & CRHNR Valves: CS and AS: 1 / HT batch.as per ASTM A 370, 2mm. Charpy-U notch,at Room temperature.Acceptance: Avg of 3specimens:36J,Single Min: 24J.
- CE-marking items: Charpy- V impact test at 20 deg.C as per ASTM A 370 for, Acceptance : Avg : 40joules, Min. single value: 27 joules.

**6.0 NON DESTRUCTIVE TEST:**

- Extent of test: for each product. Stage of test : After heat treatment.
- UT: As per SA 388 Bars of dia. = / > 50mm, Body & yoke of special class valves, all forgings & bars of SA 182 F91, F92, F23. Acceptance: ASME Sec.VIII Div. 2. Cl:3.3.4
- MPI : CS, AS: 100%, As per ASTM E 709, Linear indications like cracks, folds & other injurious defects are unacceptable.
- LPI: for SS: 100%: ASTM E165, No linear indications acceptable.

Product: **Carbon, Alloy & Stainless Steel Forgings (Boilers And Valves)**Document No.: **TDC:0:404**Rev. No.: **09**Effective date: **23/02/2010**Page **2 of 2****7.0 WORKMANSHIP AND FINISH:**

Items to be proof machined as per drawing or shot blasted for CS/AS, Pickled & passivated as per ASTM A 380 for SS, & be free from scales & defects like laps, seams, folds, cracks, etc. Machined items (except SS) to be coated with a layer of transparent rust preventive before despatch.

**8.0 REPAIR:**

Repairs by fusion welding are prohibited. Surface defects can be removed by mechanical means and defective areas smoothly dressed up with the adjacent surface. Minimum thickness after repair to meet drawing / Specification.

**9.0 MARKING AND PACKING:**

Details of stamping on each item with low stress stamps: Heat number, Specification & grade, Maker's emblem/code & Inspection Authority's seal. Forgings to be properly packed and despatched to avoid damage during transit.

**10.0 INSPECTION AND CERTIFICATION:**

(A) The inspection and tests to be witnessed by an IBR approved inspecting agency, in case the Forge shop is not recognised as a "Well known Forger" under IBR. Test certificate countersigned by applicable inspection agency for each product with following details shall accompany the product (in format approved by Boiler inspectorate for IBR items).

1. Purchase Order No.(BHEL),TDC No. & Test certificate number
2. Specification, Grade with applicable year of code, Heat Number, Drawing No.,Quantity & Size
3. Melting & forging process, Chemistry including incidental elements - Heat wise.
4. Heat treatment details of the material and test bars.
5. Mechanical test results, NDE test results with reference & acceptance standard.
6. Repair details if any, Certified copy of TC for starting material.

(B) For CE-marking items the TCs with details specified above shall be submitted as per EN-10204 (latest)

- 1.For pressure parts test certificates of type 3.1 or 3.2 is acceptable.  
Type 3.1:Suppliers shall have ISO 9001 certification certified by Notified Body recognized by European community and test certificate certified by suppliers authorized inspection representative.  
Type 3.2 – Components inspected and test certificates certified by Notified Body recognized by European community.
- 2.For non pressure parts test certificates of type 2.2 is acceptable.  
Type 2.2 – suppliers test certificates signed by suppliers authorized inspection representative with test results as required by TDC.

**11.0 AUDIT CHECKS AT BHEL**

BHEL reserves the right to carry out audit checks for chemistry, HT condition, mechanical test and NDT on representative test bars or job. Supplies found defective during check or subsequent processing at BHEL are liable for rejection.

**12.0 END USE**

Valve bodies, bonnets, discs, socket ends, body guides etc., Pressure part fittings in boilers & low temperature service like discs, socket weld tees, ells, weld neck flanges & stubs (except drum nozzles) meeting IBR, ASME Section I, ASME B16.34 and API.

Non pressure part items in boilers: For these, requirements on starting material, bend test, and inspection by IBR are not required.

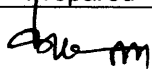
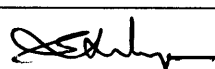
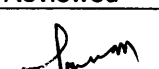
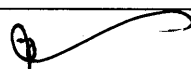
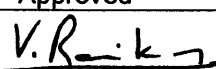
Prepared	Reviewed			Approved
 V.Kalyanaraman	 S.Selvarajan	 T.Jayaraman	 P.Loganathan	 V.Ravi kumar



BHEL GOINDWAL

TERMS AND CONDITIONS FOR  
**(Tender Enquiry No.1213-042 Dated: 15.06.2012)**

**PRE-QUALIFICATION TERMS**

- P1 “Bidders should primarily be engaged in manufacturing of Forgings. Bidder will have to submit copies of PO’s amounting to Rs 10 lacs in last financial year 2011-12, showing the business of forgings. BHEL reserves the right to accept/reject any offer based on evaluation of bidder’s capability. For verification of data presented for pre-qualification bid, BHEL may decide to visit the bidder(s) works. Any fact found deviating from bids during evaluation shall make the bidder liable to be dis-qualified.”
- P2 (i) Bidders not registered with any unit of BHEL are required to deposit an amount of Rs. **10000/- as Earnest Money (EMD)** by way of DD in favour of BHARAT HEAVY ELECTRICALS LIMITED, INDUSTRIAL VALVES PLANT, GOINDWAL SAHIB Payable at Goindwal Sahib only. MSEs, Central/State PSUs/State owned Corporations are exempted from EMD, for which relevant documentary proof has to be submitted in the envelope of EMD.
- (ii) EMD shall be forfeited if after opening the tender, the bidder revokes his tender within the validity period or increases his earlier quoted prices.
- (iii) EMD shall be forfeited if the bidder does not commence the work within the period as per LOI/PO.
- (iv) EMD submitted by all unsuccessful bidders shall be refunded normally within 20 days of finalization of Rate with interested bidders.
- (v) EMD shall not carry any interest.
- (vi) EMD amount of successful bidder shall be refunded after receipt and acceptance of total PO qty.
- P3 **IF THE OFFER IS NOT ACCOMPANIED WITH ACCEPTANCE OF TERMS AND CONDITIONS, IT SHALL BE CONCLUDED THAT ALL THE TERMS AND CONDITIONS ARE ACCEPTABLE AND NO CLAIM WHATSOEVER SHALL BE ENTERTAINED LATERON.**
- P4 A copy of pre-qualification details can be submitted even before due date of opening for evaluation planning by BHEL.



BHEL GOINDWAL

TERMS AND CONDITIONS FOR  
(Tender Enquiry No.1213-042 Dated: 15.06.2012)

**DUE DATE OF OPENING: 11.07.2012**

**1. INVITING TENDERS**

Sealed tenders in three parts; Part-I: EMD, Part II: Techno-commercial bid and Part-III: Price bid are hereby invited for the supply of Forged wedges as per applicable standards mentioned by BHEL. The relevant documents are attached with the Enquiry.

The three bids should be submitted in **separate sealed inner envelopes** duly mentioning the detail as follows:

Bid	Description	Superscription on envelope	Min documents to be submitted
Part-I	EMD envelop	<b>PART-I: EMD for tender enquiry no. 1213-042 dated 15.06.2012</b>	Draft payable at Goindwal Sahib/Proof of claiming exemption.
Part-II	Pre-qualification & Techno-Commercial bid	Part-II (Techno-Commercial) bid against tender enquiry no:1213-042 dated 15.06.2012 due for opening on 11.07.2012	<ol style="list-style-type: none"><li>1. Registration details/filled registration format</li><li>2. Acceptance of all terms and conditions.</li><li>3. Un-priced (Prices not filled) format showing taxes and duties structure.</li></ol>
Part-III	Price bid	Part-III (Price) bid against tender enquiry No: 1213-042 Dated: 15.06.2012	<b><i>No Other format shall be used for submitting the price bid.</i></b> Any variation in Unit of Supply other than that mentioned in the Price bid format shall not be accepted. <b>Rates should be mentioned in words as well as in figures. In case of any confusion rates in words shall be considered final.</b>  Anything other than price mentioned in the price bid shall be considered invalid

**PLEASE SEE AND FOLLOW THE CHECKLIST PROVIDED AT THE END**



BHEL GOINDWAL

TERMS AND CONDITIONS FOR  
(Tender Enquiry No.1213-042 Dated: 15.06.2012)

All the sealed envelopes should be put in an outer envelope clearly mentioning Tender Enquiry No., item description as "Forged Wedges" and due date of opening.

Part-I: EMD should contain:

DD of requisite amount payable at Goindwal Sahib only **OR** if exemption is sought, proper documents as required and explained in Pre-qualification para P2.

Part-II: Techno-Commercial bid should contain

- a) The details/data/ information/ supporting documents as per requirement of Pre-Qualification Bid.
- b) Acceptance of Techno-Commercial terms and conditions should be attached next. This can be attached either by signing each page of terms and conditions or a confirmation statement.  
Any deviation proposed by bidder shall be considered by BHEL at its own discretion; and if finally considered, shall carry loading factor at the discretion of BHEL.
- c) Unpriced price bid, filling all other details **except unit price**.

Sealed quotations shall reach by 1500 Hrs on due date. Part-I & II shall be opened on due date at 1530 Hrs. Based on evaluation of pre-qualification and/or techno-commercial offers, Price bids of bidders who qualify from pre-bid qualification and techno-commercial evaluation shall be opened. Date of opening of Price bid shall be informed to all successful bidders.

Part III: Price Bids:

Price quotation format shall be as attached.

The comparison among bidders shall be done on the basis of quoted rates converted to "Total landed cost to BHEL". Duties shall be payable extra against ED Gate Pass valid for CENVAT benefit.

Price quoted shall be firm and not subject to any escalation during the PO execution.

Price should be quoted on FOR Destination Goindwal Sahib basis. If not mentioned, it shall be concluded that the offer is on FOR Destination Goindwal Sahib basis. In case rates are Ex-Works basis, loading of expenses i.e., freight, transit insurance shall be done by BHEL at its discretion to arrive at Landed prices. Comparison shall be done at Landed cost to BHEL.

Tenders should be free from CORRECTION AND ERASURES. Corrections if any must be attached. Sealed Tenders can be dropped in the tender box labeled as 'Tender box for MM contracts'. This tender box is located at the entrance of Admin block BHEL Goindwal.

**2. VALIDITY OF OFFERS:**

The offers shall be kept open for acceptance for **60** days from the date of opening of the tender. In case of extension of tender opening date, the validity shall be suitably revised.



BHEL GOINDWAL

TERMS AND CONDITIONS FOR  
**(Tender Enquiry No.1213-042 Dated: 15.06.2012)**

**3. SCOPE OF SUPPLY**

Material shall be supplied as per the applicable latest Technical Document No. Material Standard requirements/ Drawing Nos. National & International material Standards shall have to be arranged by vendors themselves. **+/- 5% quantity variation is acceptable.**

**4. REPLACEMENT OF REJECTION:**

If the material is rejected due to defective workmanship during inspection or at the time of actual use, within the guarantee period (i.e. as per clause11), the rejected material shall be replaced by the supplier. Corresponding quantity shall be treated as unsupplied against respective purchase order till replacement is received at BHEL. If the material is found defective and rejected during use for which payment has already been released the rejected quantity shall be supplied free of cost by the vendor within a month of intimation of the rejection by BHEL.

**5. DELIVERY SCHEDULE:**

Supplies shall be affected and completed as per schedule mentioned in the POs/LOIs. We require **minimum 50% of total qty in first three months balance within next three months from date of PO/LOI.** Further, BHEL may release delivery schedule from time to time based upon our requirement. Vendor shall be required to complete the order as per the BHEL schedule requested.

**6. ACCESS TO MANUFACTURING PREMISES:**

While Purchase Orders placed on the vendor are under execution, authorized representatives of BHEL shall be allowed free access to the manufacturing facilities for the purpose of inspection or monitoring the progress of purchase orders. This access will also be extended to representatives of BHEL's customers accompanying the authorized representative/s of BHEL (which shall be intimated in advance), if our contractual requirements with our customers call for the same.

**7. TERMS OF PAYMENT:**

- a. Due payment against supplies received shall be due after 30 days of receipt and acceptance of material and shall be paid within next 15 days period. In case of any deviation from standard payment term mentioned BHEL at it's discretion may load on the item price at prime lending rate of SBI + 2% for the period of relaxation sought by bidder.
- b. Documents to be submitted
  - i. Commercial invoice (in duplicate)
  - ii. Excise invoice (in duplicate) valid for claiming CENVAT credit
  - iii. Original VAT invoice valid for claiming input tax credit, if applicable
  - iv. Material Test Certificates (MTC) and
  - v. Compliance Certificate.



BHEL GOINDWAL

TERMS AND CONDITIONS FOR  
(Tender Enquiry No.1213-042 Dated: 15.06.2012)

- c. Above documents should include your Registration numbers such as ECC no, PAN no, CST no, TIN/ VAT nos. etc.
- d. **It is mandatory to mention proper material codes in the invoices and separate invoices to be raised for different POs.**
- e. ***BHEL releases payment through EFT mode ONLY. Necessary details may please be submitted by filling required format before release of payment.***

**8. INSPECTION:**

1. All required tests shall be carried out by vendor at no extra cost. Relevant TCs shall accompany the consignment. **BHEL may decide to inspect itself/arrange third party at vendors' works itself as and when necessary with prior intimation to the vendor.** No additional charges shall be claimed for such inspections.
2. **Vendor will give inspection call sufficiently in advance considering the delivery period stipulated in the purchase order.**
3. Material Test Certificates (MTC), Inspection reports and Compliance/Guarantee Certificate are to be provided along with the supplies.
4. Latest applicable revisions of standards/procedures to be referred.
5. Any inspection carried out before supply by vendor/incoming stage at BHEL not withstanding, if any defect/non-conformity is noted during processing, the same shall be attended/replaced by vendor at no extra cost.

**9. PREFERENCES FOR MSE's:**

Preferences as mentioned in "Public Procurement Policy for Micro and Small Enterprises (MSEs) Order, 2012" shall be given to Micro and Small enterprises.

Main points which are mentioned in the above order are as follows:

- 20% Procurement of the tender value shall be made from MSE (Micro, Small Enterprises) firms.
- 4% from the above mentioned 20% procurement quantity shall be procured from MSE's owned by SC /ST's. Failure to participate by any MSE owned by SC/ST's this 4% quantity shall be procured from other MSEs.
- EMD shall be exempted for MSE's. All these benefits are subject to production of all statutory documents
- In tender, participating Micro and Small Enterprises quoting price within price band of L1+15 per cent shall also be allowed to supply a portion of requirement by bringing down their price to L1 price in a situation where L1 price is from someone other than a Micro and Small Enterprise and such Micro and Small Enterprise shall be allowed to supply up to 20 per cent of total tendered value. In case of more than one such Micro and Small Enterprise, the supply shall be shared proportionately (to tendered quantity).

**All these preferences are applicable subject to the submission of applicable certificates (i.e. District Industries Centers or Khadi and Village Industries Commission or Khadi and Village Industries Board or Coir Board or National**



BHEL GOINDWAL

TERMS AND CONDITIONS FOR  
(Tender Enquiry No.1213-042 Dated: 15.06.2012)

**Small Industries Corporation or Directorate of Handicrafts and Handloom or any other body specified by Ministry of Micro, Small and Medium Enterprises)**

## 10. COUNTER OFFER & LOADING CRITERIA

BHEL reserves the right to negotiate with L1 or re-float the tender in case the quoted prices are not acceptable. BHEL will give counter-offer to vendors other than L1 (for item whose qty. is greater than 1500 nos.), in order to have broader vendors base for ensuring timely delivery. Following directions shall be followed when allotting the tender quantities:

1. Tender quantity shall be divided in the proportion 60:20:20 (60% for L1, 20% for L2 and 20% for MSE's) in case the L1 vendor is not a MSE subject to following conditions:

I. L2 acceptance of L1 rates.

II. In tender, participating Micro and Small Enterprises quoting price within price band of L1+15 per cent shall also be offered 20% quantity of tender quantity at L1 price in a situation where L1 price is from someone other than a Micro and Small Enterprise. In case of more than one such Micro and Small Enterprise, the supply shall be shared equally. **If there are more than one MSE in the price band of L1+15% to whom the offer has been sent and some of them reject the offer then the remaining quantity shall be distributed equally to the MSEs accepting L1 prices.**

III. 20% from the 20% quantity (i.e. 4% of the tender quantity) offered to the MSE's shall be reserved for MSE's owned by SC/STs. In event of failure of such Micro and Small Enterprises to participate in tender process or meet tender requirements and L1 price, 4 per cent quantity for Micro and Small Enterprises owned by SC/ST entrepreneurs shall be met from other Micro and Small Enterprises.

IV. In case any MSE vendor does not accept the counter offer, the above mentioned 20% quantity shall be offered to L2 subject to its acceptance to L1 price.

V. **If there is no MSE in the Price band of L1+15% then the 20% quantity shall be offered to L2 vendor subject to his acceptance of L1 rates.**

2. In case if the L1 vendor is MSE then quantity shall be provided as 56 % and 40% in L1 and L2 vendor **respectively** subject to acceptance to above mentioned provision no.(I). 4% tender quantity shall be offered to the MSEs owned by SC/ST's in the price band of **L1+15%**. In event of failure of such Micro and Small Enterprises to participate in tender process or meet tender requirements and L1 price, 4 per cent sub-target for procurement earmarked for Micro and Small Enterprises owned by SC/ST entrepreneurs shall be met from L1 vendor.

3. In case the L1 vendor is a MSE owned by a SC/ST then the quantity shall be divided as 60% and 40% to L1 and L2 vendor respectively subject to acceptance of L1 rates by L2 vendor.

In case of non-acceptance of counter offer by L2 vendor, **the counter offer will be given to L3 vendor and all above provisions in which L2 vendor is mentioned will be studied by taking L3 vendor and the same will be continued except the highest bidder.**



BHEL GOINDWAL

TERMS AND CONDITIONS FOR  
(Tender Enquiry No.1213-042 Dated: 15.06.2012)

**In case of non- acceptance of counter offer by any vendor after above applicable provisions the whole quantity would be offered to L1 vendor.**

This ratio can be altered in case of any failure on part of L1 regarding delivery commitment/quality of material.

All above mentioned preferences shall be given to MSEs and SC/STs only on the submission of documentary evidence.

BHEL will place orders in any proportion based on pattern availability, sample development time, BHEL delivery requirement and vendor's monthly commitment if their commitment does not meet above division criteria. Performance of vendors shall be monitored as per the performance monitoring system attached.

**11. GUARANTEE:**

Vendor shall give a guarantee of 18 months from the date of dispatch or 12 months from use, against manufacturing defects, whichever is earlier.

**12. PENALTY FOR LATE DELIVERY:**

'Time is the essence of the contract'. As such, delivery of goods specified in the Purchase Orders released under the scope of this contract shall be made within the time limit prescribed therein. Penalty for late delivery will be applicable @ 0.5% per week or part thereof subject to a maximum of 5.0 %.

BHEL reserves the right to receive or not receive the material after the due date of PO.

**13. RISK PURCHASE:**

BHEL shall be entitled to terminate the contract/pending POs at any stage and to purchase elsewhere at the risk and cost of the vendor, either the whole of the goods or any part thereof which the supplier has failed to deliver or dispatch within the time stipulated as aforesaid. Vendor shall be liable for the losses, which BHEL may sustain by way of such risk purchase in addition to aforesaid penalty for delayed delivery.

**14. SUB-CONTRACT:**

The purchase order or any part thereof shall not be sub-contracted, assigned or otherwise transferred without previously obtaining the BHEL's consent in writing.



BHEL GOINDWAL

TERMS AND CONDITIONS FOR  
(Tender Enquiry No.1213-042 Dated: 15.06.2012)

**15. FORCE MAJEURE:**

If at any time during the continuance of the contract, the performance in which or in any part by either party of any obligations under the contract are prevented or delayed by reason of any war, hostilities, acts of public enemy, civil commotion, sabotage, fires, explosions, epidemics, quarantine restrictions, or acts of God (hereinafter referred to "an events" then provided the notice of happening of any such event is given by either party to the other within 21 days of the occurrence thereof, neither party shall by reason of such event be entitled to terminate the contract nor shall either party have any claim for damages against the other in respect of such non-performance and delay in performance and delivery under the contract shall be resumed as soon as practicable after such event has come to an end or ceased to exist. If the performance in whole or part of any obligation under the contract is prevented or delayed by reason of any such event, claims of extension of time shall be granted for periods considered reasonable by BHEL subject to prior notification by the vendor to BHEL of the particulars of the event and supply to BHEL, if required, of any supporting evidence. Any waiver of time in respect of partial installment shall not be deemed a waiver of time in respect of remaining deliveries.

**16. DISPUTES:**

In the event of any dispute and/or difference arising between the Vendor and BHEL as to interpretation and/or execution of the contract and/or the respective rights and liabilities of the parties, such disputes and/or differences shall be referred to the sole arbitrator nominated by BHEL. The provisions of the Indian Arbitration Act and the rules there under shall apply to such arbitration. The award passed by the arbitrator shall be final and conclusively binding on all the parties.

**17. JURISDICTION:**

The court of the place from where the purchase order is issued during the contractual period shall alone have jurisdiction to decide any dispute arising out of or in connection with the purchase order.

**18. MSME Certification:**

If the bidder is registered as any of Micro/Small/Medium enterprise as defined in Micro Small and Medium Enterprises Development Act, 2006; a copy of registration certificate to be attached.

**19. CLARIFICATIONS**

The correspondence exchanged against the tender from both tenderer and BHEL through email are considered as valid document legally though it is not signed. It is treated as valid confirmations made on behalf of the respective company and very much comes under the legal ambit of the business transaction and hence it is binding on both the parties to the business. Any transaction pertaining to the tender from both the parties of business done



BHEL GOINDWAL

TERMS AND CONDITIONS FOR  
**(Tender Enquiry No.1213-042 Dated: 15.06.2012)**

round the clock irrespective of the office or business hours of the companies, are valid legally and binding on both the parties. This applies to the extent only in such cases where deadline time for transaction is not specifically declared by either or both the parties to the business.

**20. LOI(Letter of Intent)**

BHEL may issue LOI prior to the PO for any reason whatsoever. The LOI in such cases is to be treated as PO for all practical purposes and all the Terms & Conditions of the tender shall be applicable from the date of issue of LOI.

**21. GENERAL:**

- a) BHEL will not be bound by any power of attorney granted by the vendors or by changes in the composition of the firm made subsequent to the execution of the contract. They may, however, recognize such power of attorney and changes after obtaining proper legal advice, the cost of which will be chargeable to the vendor concerned.
- b) BHEL reserves the right to extend the due date of opening, which shall be informed. Validity of offer shall be deemed to be revised accordingly.
- c) BHEL reserves the right to accept or reject any part or whole of the tender of a bidder by assigning a valid reason thereof. BHEL reserves the right to cancel the tender without assigning any reason thereof and without any obligation before any commitment.
- d) If possible, please submit soft copy of price quotation [copied on a blank CD of standard make] put in the sealed offer.
- e) Acceptance of all terms and conditions, in the form of signed copy of T&C or confirmation separately written, shall be submitted along with quotation. If nothing is mentioned, it shall be concluded that terms and conditions are acceptable.
- f) BHEL reserves the right to delete any item from the tender at any stage of tender process without assigning any reason.
- g) **Bidders, who are not currently on registered list of BHEL IVP Goindwal Sahib, may submit duly filled format for “Vendor Registration form”.** The form can be downloaded from our website [www.bhel.com](http://www.bhel.com) or can be requested at [vishal@bhelivp.in](mailto:vishal@bhelivp.in) or [vm@bhelivp.in](mailto:vm@bhelivp.in)  
Registered vendors with BHEL IVP GWL have to mention their vendor code. Registered vendors with any other unit of BHEL are also required to mention the vendor code given by respective BHEL unit along with photocopy of latest POs from BHEL unit.



BHEL GOINDWAL

TERMS AND CONDITIONS FOR  
(Tender Enquiry No.1213-042 Dated: 15.06.2012)

**22. BANNED FIRMS:**

The offers of the bidders who are on the banned list as also the offer of the bidders, who engage the services of the banned firms, shall be rejected. The list of banned firms is available on BHEL website [www.bhel.com](http://www.bhel.com).

**CHECKLIST AND SEQUENCE OF DOCUMENTS TO BE SUBMITTED IN THREE PARTS  
BIDS**

S. No.	Document	Status	
1	Envelope should contain EMD/Proof regarding Exemption of EMD	Yes, Sealed	
2.	Techno-commercial bid sealed in separate envelope superscribing tender enquiry detail, due date of opening, sender address	Sealed envelope marked as Part-II "Techno-commercial Bid"	Yes, sealed
3.	Price Bid sealed in separate envelope superscribing tender enquiry detail, due date of opening, sender address	Sealed envelope marked as Part-III "Price Bid"	Yes, sealed
3.	All three sealed envelopes put in an outer envelope mentioning all details like Enquiry no., description, due date	Yes	