

## Scope of Supply

Item No	Material Code	Material Description	Drawing No/Rev No	Quantity (Nos)
10	964529470000	END COVER 11-5M-4259	3V425907724/01	815
20	964529480000	END COVER13-5/8-5M-4265	3V426507724/01	555
30	964529460000	END COVER7-1/16--4109	3V410907724/01	386
40	964529380000	END COVER.21-1/4-4127	3V412707724/01	265
50	964529500000	END COVER 7-10M-4269	3V426907724/01	145
60	220710550000	END COVER-1381	2V138101767/01	140
70	964529400000	END COVER13-5/8-3M-4112	3V411207724/01	125
80	220710690000	END COVER-2214	2V221401767/01	120
90	964529440000	END COVER.3-1/8--4882	3V488207724/01	85
100	220710540000	END COVER-1380	2V138001767/01	80
110	220710140000	END COVER-2341	2V234101767/01	60
120	220710270000	END COVER-0187	2V018701767/01	20
130	220710150000	END COVER-2302	2V230201767/01	15
140	964529510000	END COVER13-10M-4369	3V436907724/01	10
150	964690610000	HBD END COVER.3-1/16-4J71	3V488207724/01	10
160	220710180000	END COVER-0205	2V020501767/01	10

DRAWING NO. 2-V-0000-01767/04

ALL DIMENSIONS ARE IN MILLIMETRES. FOR TOLERANCES OF UNTOLERANCED DIMENSIONS DURING MANUFACTURE REFER RELEVANT QCP / QP

**DIMENSIONAL TOLERANCES**  
 FOR O.D. UPTO  $\phi 500$   $\pm 0.15$   
 FOR O.D. ABOVE  $\phi 500$   $\pm 0.20$

SL.No.	NP	NB	DRG.No.	DIMENSIONS					MATL. CODE.	
				$\phi$ D	D1	t	rx $\phi$	NET WT (kg)		
01	NP:10&16	100	2-V-1391-01767/1	215	180	3	4x90'	0.117	22071005	
02		125	2-V-0103-01767/1	245	210	3	4x90'	0.153	22071006	
03		150	2-V-1373-01767/1	SAME AS IN SL.No:-56						
04		200	2-V-1394-01767/1	335	295	3	6x60'	0.286	22071008	
05		250	2-V-1395-01767/1	405	355	3	6x60'	0.420	22071009	
06		300	2-V-1317-01767/1	460	410	3	6x60'	0.542	22071010	
07		400	2-V-1318-01767/1	580	525	6	8x45'	1.350	22071011	
08		600	2-V-1209-01767/1	840	770	6	8x45'	2.850	22071012	
09	NP:10,16&40	15	2-V-2301-01767/1	95	65	3	4x90'	0.021	22071013	
10		20	2-V-2341-01767/1	105	75	3	4x90'	0.027	22071014	
11		25	2-V-2302-01767/1	115	85	3	4x90'	0.032	22071015	
12		32	2-V-2242-01767/1	135	100	3	4x90'	0.044	22071016	
13		40	2-V-0203-01767/1	145	110	3	4x90'	0.051	22071017	
14		50	2-V-0204-01767/1	160	125	3	4x90'	0.063	22071003	
15		65	2-V-0205-01767/1	180	145	3	4x90'	0.080	22071018	
16		80	2-V-1371-01767/1	SAME AS IN SL.No. 54						
17		100	2-V-1372-01767/1	SAME AS IN SL.No:- 55						
18		125	2-V-2226-01767/1	SAME AS IN SL.No:- 41						
19		150	2-V-2411-01767/1	300	250	3	4x90'	0.226	22071021	
20		200	2-V-2412-01767/1	375	320	3	6x60'	0.356	22071022	
21		250	2-V-0181-01767/1	445	385	3	6x60'	0.503	22071023	
22		300	2-V-0183-01767/1	510	450	3	8x45'	1.031	22071024	
23		400	2-V-1217-01767/2	635	585	6	8x45'	1.709	22071025	
24	500	2-V-1218-01767/1	755	670	6	8x45'	2.279	22071026		
25	NP:64	50	2-V-0187-01767/1	175	135	3	4x90'	0.075	22071027	
26		65	2-V-0188-01767/1	200	160	3	4x90'	0.100	22071064	
27		80	2-V-1378-01767/1	SAME AS IN SL.No:-65						
28		100	2-V-0103-01767/1	SAME AS IN SL.No:-2						
29		150	2-V-0191-01767/1	340	280	3	4x90'	0.290	22071030	
30		200	2-V-1395-01767/1	SAME AS IN SL.No:-5						
31		250	2-V-0182-01767/1	470	400	3	6x60'	0.560	22071032	
32		300	2-V-0184-01767/1	530	460	3	8x45'	1.110	22071033	
33		NP:64&100	15	2-V-2341-01767/1	SAME AS IN SL.No:-10					
34			20	2-V-2214-01767/1	SAME AS IN SL.No:-43					
35	25		2-V-2242-01767/1	SAME AS IN SL.No:-12						
36	32		2-V-1370-01767/1	SAME AS IN SL.No:-53						
37	40		2-V-1377-01767/1	SAME AS IN SL.No:-64						
38	NP:100	50	2-V-1371-01767/1	SAME AS IN SL.No:-54						
39		65	2-V-1391-01767/1	SAME AS IN SL.No:-1						
40		80	2-V-1372-01767/1	SAME AS IN SL.No:-55						
41	NP:250	100	2-V-2226-01767/1	265	210	3	4x90'	0.173	22071038	
42		150	2-V-0354-01767/1	350	290	3	6x60'	0.207	22071068	
43		15	2-V-2214-01767/1	125	90	3	4x90'	0.037	22071069	
44	25	2-V-0203-01767/1	SAME AS IN SL.No:-13							
45	40	2-V-0205-01767/1	SAME AS IN SL.No:-15							
46	65	2-V-2225-01767/1	SAME AS IN SL.No:-55							
47	250	2-V-0347-01767/1	585	490	3	8x45'	1.328	22071039		

SL.No.	NP	NB	DRG.No.	DIMENSIONS					MATL. CODE.
				$\phi$ D	D1	t	rx $\phi$	NET WT (kg)	
48	NP:2.5	800	2-V-0112-01767/1	975	920	6	12x30'	3.864	22071001
49		1200	2-V-0113-01767/1	1375	1320	6	16x22.5'	7.800	22071002
50	NP:6	300	2-V-0109-01767/1	435	395	3	6x60'	0.486	22071072
51	NP:25	200	2-V-0126-01767/1	360	310	3	6x60'	0.329	22071073
52		300	2-V-0127-01767/1	485	430	3	8x45'	0.602	22071074
53	150 LBS.	2"	2-V-1370-01767/1	152	121	3	4x90'	0.050	22071040
54		3"	2-V-1371-01767/1	190	152	3	4x90'	0.082	22071041
55		4"	2-V-1372-01767/1	229	190	3	4x90'	0.120	22071042
56		6"	2-V-1373-01767/1	279	241	3	4x90'	0.180	22071043
57		8"	2-V-0191-01767/1	SAME AS IN SL.No:-29					
58		10"	2-V-1395-01767/1	SAME AS IN SL.No:-5					
59		12"	2-V-1376-01767/1	483	432	3	6x60'	0.544	22071046
60		14"	2-V-1386-01767/1	533	476	6	6x60'	0.654	22071047
61	300 LBS.	16"	2-V-1387-01767/1	597	540	6	8x45'	0.824	22071048
62		20"	2-V-1512-01767/1	695	635	6	10x36'	1.200	22071049
63		24"	2-V-1388-01767/1	813	749	6	10x36'	1.534	22071050
64		2"	2-V-1377-01767/1	165	127	3	4x90'	0.061	22071051
65		3"	2-V-1378-01767/1	209	168	3	4x90'	0.098	22071052
66		4"	2-V-1379-01767/1	254	200	3	4x90'	0.147	22071053
67		6"	2-V-1380-01767/1	317	270	3	6x60'	0.232	22071054
68		8"	2-V-1381-01767/1	381	330	3	6x60'	0.336	22071055
69	150 C	10"	2-V-1382-01767/1	444	387	3	8x45'	0.457	22071056
70		12"	2-V-1383-01767/1	521	451	3	8x45'	0.630	22071057
71		14"	2-V-1384-01767/1	584	514	6	10x36'	0.784	22071058
72		1 1/2"	2-V-1370-01767/1	SAME AS IN SL.No:-53					
73	NP:10	300	2-V-0522-01767/1	440	400	3	6x60'	0.52	22071060
74		400	2-V-0537-01767/1	565	515	6	8x45'	1.31	22071061
75		500	2-V-0538-01767/1	670	620	6	10x36'	1.5	22071062
76		600	2-V-0539-01767/1	780	725	6	10x36'	1.7	22071063
77		800	2-V-0503-01767/1	1015	950	6	12x30'	2.5	22071075
78	150 C	26"	2-V-N834-01767/1	785	745	6	9x40'	1.7	22071076
79		28"	2-V-N847-01767/1	835	795	6	10x36'	1.9	22071077
80		30"	2-V-N848-01767/1	885	845	6	11x32.7'	2.1	22071078
81		32"	2-V-N827-01767/1	940	900	6	12x30'	2.3	22071079
82		36"	2-V-N988-01767/1	1170	1085	6	8x45'	3.5	22071080
83	36"	2-V-N846-01767	1055	1010	6	11x32.7'	2.7	22071081	

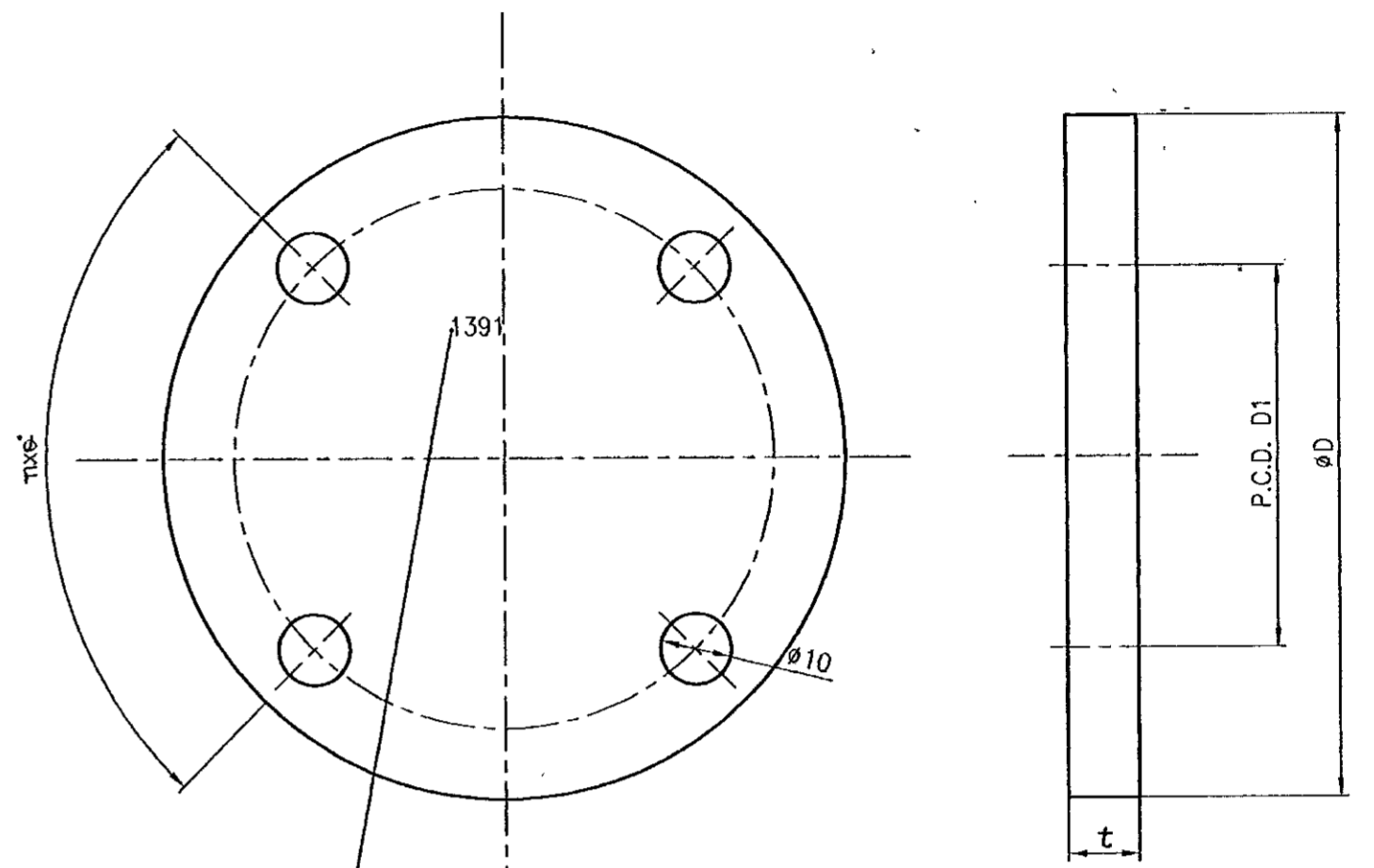

IDENTIFICATION MARK TO BE PAINTED ON THE SMOOTH SURFACE  
 (FOR EXAMPLE: "1391" FOR SL.No.1, DRG.No.2-V-1391-01767/1)

MATL SPECN. STANDARD HARD BOARD IS.1658

No OFF	DESCRIPTION	MATL CODE	MATL SPECN	HEAT TREATMENT	SCRAP SORT	NET WT (kg)	GROSS WT (kg)	DRAWING No	ITEM No
	TYPE OF PRODUCT OR NAME OF CUSTOMER/PROJECT								
	RETRACED WITH REV.4 ON 19.7.2000								
	BHARAT HEAVY ELECTRICALS LTD.								
	UNIT: HIGH PRESSURE BOILER PLANT. TRUCHIRAPALLI-620014.								
	DRN	NAME	SIGN	DATE	NO.OF VAR.				
	CHD	R.L.NARAYANAN	[Signature]	19/7/2000	1				
	APPD	M.RAJAKUMAR	[Signature]	19/7/2000	1				
	DEPT	V L	SCALE	WEIGHT (KG).	REFERENCE INFORMATIONS				
	CODE	320	N T S		CAD REF:- C201767				
	TITLE	END COVER			CARD CODE	DRAWING NO.			
		U 01	2-V-0000-01767			04			

REV	DATE	ALTERED	R.L.
04	19.7.2K	CHD & APPD	M.R.K.
SL.No.83 INCLUDED. DIMS.CORRECTED FOR SL.No.78 TO 82. DCN NO.HM 0459			

CAUTION: The information on this document is the property of BHARAT HEAVY ELECTRICALS LTD. It must not be used directly or indirectly in any way detrimental to the interest of the company.

SL No.	FLANGE RATINGS	DRAWING NUMBER	MATL. CODE	∅ D	PCD	t	NET Wt (Kg)	SUPERSEDED DRG	BHEL PART No.
01	13 5/8" - 2000	SAME AS SERIAL NUMBER 05							
02	21 1/4" - 2000	3-V-4127-07724/01	96 452 938	813	724	6	3.42	VPS-001-9036	4127309
03	3 1/8" - 3000	SAME AS IN SERIAL NUMBER 09							
04	9" - 3000	SAME AS IN SERIAL NUMBER 19							
05	11" - 3000	3-V-4111-07724/01	96 452 939	546	470	6	1.55	VPS-002-9036	4111310
06	13 5/8" - 3000	3-V-4112-07724/01	96 452 940	610	534	6	1.92	VPS-003-9036	4112311
07	20 3/4" - 3000	3-V-4832-07724/01	96 452 941	858	750	6	3.81	VPS-004-9036	4832312
08	2 1/16" - 5000	3-V-4879-07724/01	96 452 942	216	165	3	0.12	VPS-005-9036	4879313
09	2 9/16" - 5000	3-V-4881-07724/01	96 452 943	245	191	3	0.15	VPS-006-9036	4881314
10	3 1/8" - 5000	3-V-4882-07724/01	96 452 944	267	203	3	0.18	VPS-007-9036	4882315
11	4 1/16" - 5000	3-V-4733-07724/01	96 452 945	312	242	3	0.25	VPS-008-9036	4733316
12	7 1/16" - 5000	3-V-4109-07724/01	96 452 946	394	318	6	0.40	VPS-009-9036	4109317
13	11" - 5000	3-V-4259-07724/01	96 452 947	585	483	6	1.77	VPS-010-9036	4259318
14	13 5/8" - 5000	3-V-4265-07724/01	96 452 948	673	591	6	2.35	VPS-011-9036	4265319
15	1 13/16" - 10000	3-V-4178-07724/01	96 452 949	188	146	3	0.09	VPS-012-9036	4178320
16	2 1/16" - 10000	SAME AS IN SERIAL NUMBER 08							
17	2 9/16" - 10000	SAME AS IN SERIAL NUMBER 09							
18	3 1/16" - 10000	SAME AS IN SERIAL NUMBER 10							
19	4 1/16" - 10000	SAME AS IN SERIAL NUMBER 11							
20	7 1/16" - 10000	3-V-4269-07724/01	96 452 950	480	404	6	0.59	VPS-013-9036	4269321
21	11" - 10000	SAME AS IN SERIAL NUMBER 14							
22	13 5/8" - 10000	3-V-4369-07724/01	96 452 951	769	673	6	3.00	VPS-014-9036	4369322
23	3 1/16" - 15000	3-V-4J71-07724/01	96 469 061	290	230	3	0.3	VPS-015-9036	4J71323

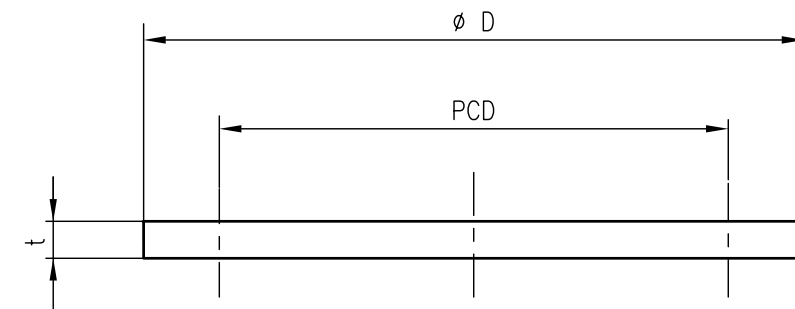

IDENTIFICATION MARK  
TO BE PAINTED ON THE  
SMOOTH SURFACE BY  
RESPECTIVE-BHEL PART No  
SHOWN IN TABULATION

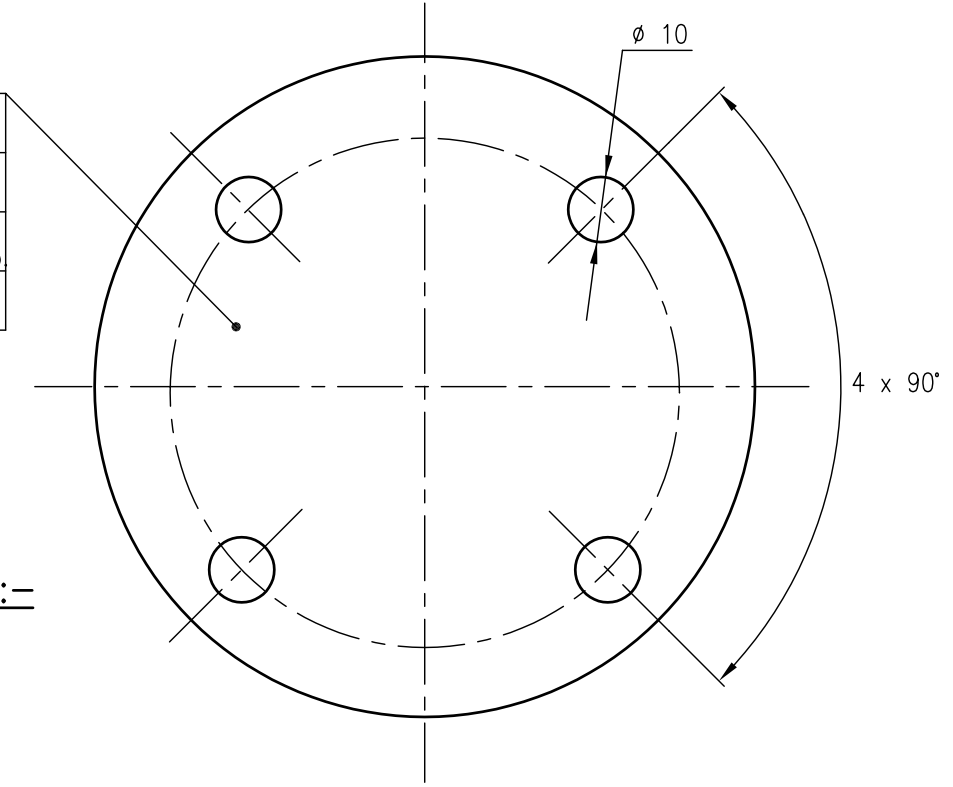

**DIMENSIONAL TOLERANCES:-**

1. FOR OD UPTO ∅ 500  $\begin{matrix} 0 \\ -3.0 \end{matrix}$
2. FOR OD ABOVE ∅ 500  $\begin{matrix} 0 \\ -5.0 \end{matrix}$

CAD REF No. o307724

No OFF	DESCRIPTION	MATL CODE	MATL SPECN	HEAT TREATMENT	SCRAP SORT	NET WT (kg)	GROSS WT (kg)	DRAWING No	ITEM No
			STANDARD HARD BORAD IS 1658						

TYPE OF PRODUCT OR NAME OF CUSTOMER/PROJECT

BHARAT HEAVY ELECTRICALS LTD., UNIT: HIGH PRESSURE BOILER PLANT. TIRUCHIRAPALLI-620014.	DRN	T.RAJARAMAN	SIGN	<i>T.Rajaraman</i>	DATE	27-6-05	NO. OF VAR.
	CHD	T.RAJARAMAN	SIGN	<i>T.Rajaraman</i>	DATE	27-6-05	
	APPD	V.ALAGARSWAMI	SIGN	<i>V.AlagarSwami</i>	DATE	27-6-05	

DEPT	VL	SCALE	WEIGHT (KG).	REFERENCE INFORMATION	NO. OF ITEMS
CODE	340	NTS			
TITLE	END COVER			DRAWING NO.	REV
			CARD CODE	3-V-0000-07724	02
			U 01		

CAUTION: The information on this document is the property of BHARAT HEAVY ELECTRICALS LTD. It must not be used directly or indirectly in any way detrimental to the interest of the company.

DCP No.	ALTERED	APPD
	CHD	DT. 27-6-05
REV.	02	
ZONE	SL NO 23 ADDED.	



# BHARAT HEAVY ELECTRICALS LTD

VALVES PURCHASE

Trichy - 620 014. India

CONFIRMATION TO TERMS AND CONDITIONS

**Enquiry Reference:** ENBPS02366

<b><u>TERMS &amp; CONDITION</u></b>	<b><u>VENDOR CONFIRMATION</u></b>
<p><b>a. Vendor Quotation Reference No. and Date</b></p>	
<p><b>b. Pre-Qualification Requirement</b></p> <p>Vendor to furnish records of previous supplies of same or similar category items to any Central / State Govt Organization / PSU / Public Listed Company.</p>	
<p><b>c. Vendor should give confirmation to BHEL's Technical Specification. To fulfil this criteria vendor shall submit the specification duly sealed and signed.</b></p> <p>Any deviations from the specification are to be furnished separately as "Schedule of Deviation".</p> <p>If there is no deviation vendor should indicate <b>"No Deviation"</b>.</p>	
<p><b>d. The offer has to be submitted as a <b>Two-part bid</b> (Techno-commercial &amp; Price bid)</b></p>	
<p><b>e. The tender will be finalized on item wise basis</b></p>	
<p><b>f. Terms of Payment:</b>  <u>Indigenous Supplier (Non-MSE):</u> 100% direct EFT Payment after 60 days from the date of receipt and acceptance of materials at BHEL stores / against site acknowledgement.  <u>Indigenous Supplier (MSE):</u> Payment will be as per MSMED Act, 2006. (Udyam Registration Certificate to be enclosed along with the offer)</p>	
<p><b>g. Liquidated Damage:</b> Liquidated damages shall be 0.5% of the undelivered portion per week of the delay or part thereof subject to a maximum of 10% of the total order value.</p>	
<p><b>h. Delivery Terms:</b>            Prices shall be quoted on "<b>FIRM PRICE</b>" basis only.  <u>For Indigenous Supplies:</u> FOR BHEL Trichy</p>	
<p><b>i. Validity of Offer:</b> Prices should be valid for 60 days from the date of part-1 bid opening of this tender. The delay in responding to BHEL technical clarification beyond four days will be subsequently added to the validity period, Revised Price Bids will not be encouraged.</p>	
<p><b>j. Delivery period:</b>            Delivery period should be <b>6 weeks</b> from the date of purchase order.            If supplier offers more than the required delivery period BHEL will operate 0.5% loading factor for evaluation of their offer for every week delay subject to a maximum of <b>2%</b>. Any other delivery period after loading to maximum will be rejected.</p>	
<p><b>k. Risk Purchase:</b>            Risk purchase penalties as per clause 5 of general terms and conditions is applicable for this enquiry. Non acceptance to risk purchase clause the offer is liable for rejection.</p>	



# BHARAT HEAVY ELECTRICALS LTD

VALVES PURCHASE

Trichy - 620 014. India

CONFIRMATION TO TERMS AND CONDITIONS

**Enquiry Reference:** ENBPS02366

<b><u>TERMS &amp; CONDITION</u></b>	<b><u>VENDOR CONFIRMATION</u></b>
<b>l. Guarantee Clause:</b> The vendor shall give a guarantee for the performance of his supplies for a period of eighteen months from the date of dispatch or twelve months from the date of commissioning whichever is earlier.	
<b>m. Performance Bank Guarantee:</b> Performance Bank Guarantee is not applicable for this enquiry	
<b>n. Counter-offering</b> Counter-offering is not applicable for this enquiry	
<b>o. Integrity Pact</b> Integrity pact is not applicable for this enquiry	

Name:

Seal and Signature of authorised signatory



Maharatna Company

# BHARAT HEAVY ELECTRICALS LTD

VALVES PURCHASE

Trichy - 620 014, India

GENERAL TERMS AND CONDITIONS

Enquiry Reference: **ENBPS02366**

## 1. QUOTATIONS:

### a. BID system:

- i. Two part bid: The offers are invited in Two part bid system (Part I will be Techno-commercial bid and part II will be Price Bid). Techno-commercially suitable vendors alone will be intimated for price bid opening.

### b. Submission of offer:

- i. Offer called through e-Procurement mode: The bidder shall submit the bid online in BHEL e-Procurement portal at <https://eprocarebhel.co.in/>

The bidder would be required to register on the above e-procurement portal for submitting their bids. Offers through email and hardcopy are not acceptable.

- c. **Regulations**: Offers should be free from correction and erasures. Corrections if any must be attested. All amounts shall be indicated both in words as well as figures. In case of a difference between the amount quoted in words and figures, the amount quoted in words shall prevail.
- d. **PVC**: Price Variation clause not acceptable. Prices should be firm.
- e. **Catalogue**: Manufacturer's name, Trade Mark or Patent No. if any should be specified. Illustrative leaflets giving technical particulars are required along with quotation.
- f. **Samples**: Samples should be submitted separately, if specially requested in tender, before the due date of the enquiry. They should be clearly marked with the enquiry reference and date on the enclosing cover to facilitate identification.
- g. **GST Number**: GST registration number, HSN number (Item wise) with applicable taxes should be mentioned in the offer. If the vendor is not GST registered the offer is liable for rejection.
- h. **Deviation**. Any deviations from the specification are to be furnished separately as "Schedule of Deviation". If there is no deviation, vendor should indicate "No Deviation" in the offer.
- i. **Confirmation**: Confirmation for compliance is to be given in the offer for all the techno commercial conditions specified in the tender.

## 2. COMMERCIAL TERMS & CONDITIONS:

### a. Terms of Payment:

#### **For Indigenous Suppliers:**

If the materials are receivable at BHEL Stores, Trichy:

Payment term is 100% direct Payment after 60 days from the date of receipt and acceptance of materials.

Any deviation in the above payment terms, any other conditions in payment terms or any other payment terms will not be accepted and offers will not be considered.

**For New Suppliers:** For new suppliers not registered with BHEL, Trichy for the product, payment shall be made 60 days after receipt and acceptance of materials.

- b. **Liquidated Damage**: Liquidated damages shall be 0.5% of the undelivered portion per week of the delay or part thereof subject to a maximum of 10% of the total order value.

Any deviation from the above LD clause, loading will be applied to the extent to which it is not agreed by the bidder (at offered value)

Under GST regime, BHEL has to discharge GST liability on LD recovered from suppliers. Hence applicable GST shall also be recoverable from suppliers on LD amount. Debit note will be issued by BHEL for this amount, indicating the respective supply invoice number.

### c. Delivery Terms:

For Indigenous Suppliers: FOR BHEL Trichy inclusive of freight and insurance

- d. **Validity of Offer**: Prices should be fixed and should be valid for period as mentioned in the "Confirmation to the Terms and Conditions" attached.
- e. **Delivery period**: Delivery schedule will be as mentioned in the "Confirmation to the Terms and Conditions" attached. If supplier offers more than the required delivery period BHEL will operate 0.5% loading factor for evaluation of their offer for every week delay.



# BHARAT HEAVY ELECTRICALS LTD

## VALVES PURCHASE

Trichy - 620 014, India

### GENERAL TERMS AND CONDITIONS

Enquiry Reference: **ENBPS02366**

- f. **Guarantee period:** The vendor shall give a guarantee for the performance of his supplies for a period of **eighteen months** from the date of dispatch or **twelve months** from the date of commissioning whichever is earlier.
- g. **Miscellaneous:** Any conditions which might have been quoted by the seller and are in contravention to the terms of PO and which have not been specifically accepted by Purchaser will not be applicable to the contract/PO.
- h. **Performance Bank Guarantee:** If tender calls for Performance Bank Guarantee, vendor should provide a performance bank guarantee (PBG) in BHEL format for 10% of the total Purchase order value valid for warranty/guarantee period with an additional claim period of 2 months. PBG should be issued from list of consortium banks.
- i. **Counter Offering:** If counter offering is applicable for the enquiry, the L1 rates will be counter-offered to other eligible vendors as per below points
  - In case there are only two qualified offers for any item, the L1 rate will be counter-offered to the L2 vendor.
  - In case of more than two qualified offers for any item, the L1 rates will be counter-offered to maximum (n-1) vendors (where 'n' is the no. of techno-commercially qualified vendors) or the no. of vendors required (as mentioned in the "Confirmation to the Terms and Conditions" attached), whichever is lower.
  - In case a lower ranked vendor does not accept the counter-offered rates, the rates may be offered to next higher ranked vendor.
  - The manner of splitting of the enquiry quantity across L1 and counter-offer accepted vendors will be as per the ratios mentioned in the "Confirmation to the Terms and Conditions" attached.

### **3. COMPLIANCE / ACCEPTANCE REQUIRED FOR FOLLOWING POINTS TO ENSURE INPUT TAX CREDIT**

- a. Response to Tenders for Indigenous supplier/Vendor will be entertained only if the vendor has a valid GST registration No (GSTIN) which should be clearly mentioned in the offer. If the Vendor is exempted from GST registration, a declaration with due supporting documents need to be furnished for considering the offer. Vendor under composition scheme should declare that he is a composition Vendor supported by the screen shot taken from GST portal. The dealer has to submit necessary documents if there is any change in status under GST.
- b. Supplier shall mention their GSTIN in all their invoices (incl. credit Notes, Debit Notes) and invoices shall be in the format as specified/prescribed under GST laws. Invoices shall necessarily contain Invoice number (in case of multiple numbering system is being followed for billing like SAP invoice no, commercial invoice no etc., then the Invoice No. which is linked/uploaded in GSTN network shall be clearly indicated), Billed to party (with GSTIN) & Shipped to party details, item description as per PO, Quantity, Rate, Value, applicable taxes with nomenclature (like IGST, SGST, CGST & UTGST) separately, HSN/ SAC Code, Place of Supply etc.
- c. Invoices will be processed only upon completion of statutory requirement and further subject to following:
  - i. Vendor declaring such invoice in Form GST ANX-1
  - ii. Receipt of Goods or Services and Tax invoice by BHEL
- d. All invoices shall bear the HSN Code for each item separately (Harmonized System of Nomenclature)/ SAC code (Services Accounting Code).
- e. As the continuous uploading of tax invoices in GSTN portal (in GST ANX-1) is available for all (i.e. both Small & Large) tax payers under proposed new GST Return System, all invoice raised on BHEL may be uploaded immediately in GST portal on despatch of material /rendering of services. The supplier shall ensure availability of Invoice in GST portal before submission of invoice to BHEL. Invoices will be admitted by BHEL only if the invoices are available in GSTN portal (in BHEL's GST ANX-2).
- f. A declaration to the effect that all invoice particulars are/were uploaded in the GSTN network/ portal & all tax liability as per GST rules and regulations have been and will be discharged, shall be mentioned in the invoice. If not mentioned in the invoice, a separate declaration shall be submitted as per the requirement of BHEL.
- g. All documents like Test Certificate, LR copy, any other document mentioned in PO, shall be sent along with the vehicle/consignment. For all consignments received within the calendar month, input credit will be availed within that month in line with monthly returns filing cycle. In case of any discrepancy in the document or non-submission of documents mentioned in the PO, then BHEL will not be able to accept or account the material, in such case availing of tax credit will be deferred to next month or so.
- h. In case of discrepancy in the data uploaded by the supplier in the GSTN portal or in case of any shortages or rejection in the supply, then BHEL will not be able to avail the tax credit and will notify the supplier of the same. Supplier has to rectify the data discrepancy in the GSTN portal or issue credit note or debit note (details also to be uploaded in GSTN portal) for the shortages or rejections in the supplies or additional claims, within the calendar month informed by BHEL.



# BHARAT HEAVY ELECTRICALS LTD

## VALVES PURCHASE

Trichy - 620 014, India

### GENERAL TERMS AND CONDITIONS

Enquiry Reference: **ENBPS02366**

- i. In cases where invoice details have been uploaded by the vendor but failed to remit the GST amount to GST Department (Form PMT-08 or Form GST RET-01 to be submitted) within stipulated time, then GST paid on the invoices pertaining to the month for which GST return not filed by the vendor will be recovered from the vendor along with the applicable interest (currently 24% p.a) and all subsequent bills of the vendor will not be processed till filing of the GST return by the vendor.
- j. Under GST regime, BHEL has to discharge GST liability on LD recovered from suppliers/contractors. Hence applicable GST shall also be recoverable from suppliers/contractors on LD amount. For this, debit note will be issued by BHEL indicating the respective supply invoice number.
- k. In case any changes in taxes and duties as per Gov. Notification (including GST), the same shall be applicable from time to time.
- l. Duplicate copy of the Invoice meant for the transporter should accompany the material as stipulated under CE Rules 52A and 172C OR 57CE.
- m. TDS on GST shall be applicable as per the GST Act.
- n. In case GST credit is denied to BHEL due to non-receipt or delayed receipt of goods and/ or tax invoice or expiry of timeline prescribed in GST law for availing such ITC, or any other reasons not attributable to BHEL, GST amount claimed in the invoice shall be disallowed to the vendor.
- o. Where any GST liability arising on BHEL under Reverse Charge (RCM), the vendor has to submit the invoices to BHEL well within the timeline prescribed in GST Law, to enable BHEL to discharge the GST liability. If there is a delay in submission of invoice by the vendor resulting in delayed payment of GST by BHEL along with Interest, then such Interest payable or paid shall be recovered from the vendor.
- p. GST TDS will be deducted as per Section 51 of CGST Act 2017 and in line with Notification 50/2018 – Central Tax dated 13.09.2018. GST TDS certificate which will be generated in GST portal subsequent to vendor accepting the TDS deduction in the GST portal, will be issued to the vendor.

#### **4. SPECIAL PROVISIONS FOR MICRO AND SMALL ENTERPRISES (MSE):**

- a. 25% of the tendered quantity is earmarked for MSE suppliers in this tender.
- b. If L1 vendor (or) Counter offer accepted vendor/s is from a Micro / Small enterprise which put together covers 25% of the total tendered quantum, the 25% earmarking provision is not applicable.
- c. Out of the 25% tendered quantity reserved for MSE suppliers, 6.25% shall be earmarked for procurement from MSE owned by SC / ST entrepreneurs. In the event of failure of such Micro and Small enterprises to participate in the tender process or meet the tender requirements and the L1 price, the 6.25% sub-target for procurement ear-marked MSE owned by SC / ST entrepreneurs shall be met with other MSE enterprise/s.
- d. 3% reservation for women owned MSEs within the above mentioned 25% reservation. In the event of failure of such Micro and Small enterprises to participate in the tender process or meet the tender requirements and the L1 price, the 3% sub-target for procurement ear-marked MSE owned by women entrepreneurs shall be met with other MSE enterprise/s. The definition for MSEs owned by Women Entrepreneurs is clarified as:
  - i. In case of proprietary MSE, proprietor shall be woman.
  - ii. In case of partnership MSE, the women partners shall be holding at least 51% share in the unit.
  - iii. In case of private limited companies, at least 51% share shall be held by the women promoters.
- e. In case MSE vendor participating in the tender quotes within the price band of LI +15%, they will be allowed to supply the portion of the requirement subject to acceptance of LI price by MSE vendor. In case of more than one such MSE, the supply shall be shared proportionately, provided the available quantum can be split.
- f. In a tender where both MSE and Non-MSE Vendors have participated and non-MSE Vendor has become the lowest bidder and the quantum envisaged in the tender cannot be split, then the MSE vendor will be given preference for ordering the available quantum provided the MSE vendor quoted price is within L1 + 15%, and if the MSE vendor accepts the L1 rate.
- g. MSE suppliers can avail the intended benefits only if,

The vendor submits along with offer, a copy of the Udyam Registration Certificate.

(or)

The vendor has already submitted the above documents for the financial year of the date of part-1 bid opening and the MSE status has been updated in BHEL Trichy's records.

Non submission of such documents will lead to consideration of their bids at par with other bidders and MSE status of such suppliers shall be shifted to Non MSE supplier till the supplier submits these documents.



# BHARAT HEAVY ELECTRICALS LTD

## VALVES PURCHASE

Trichy - 620 014, India

### GENERAL TERMS AND CONDITIONS

Enquiry Reference: **ENBPS02366**

- h. Definitions of MSEs owned by SC/ST is under:
- In case of proprietorship firm, proprietor must be SC/ST.
  - In case of partnership firm, the SC/ST partners must be holding at least 51% shares in the unit.
  - In case of private limited companies, at least 51% share must be held by SC/ST promoters.
  - The caste/Tribe/Community certificate issued by the following authorities in the prescribed form for SCs/STs can be considered.
- i. Authorized to Issue SC/ST certificate:
- District Magistrate/Additional District Magistrate/Collector/Deputy commissioner/Additional Deputy Commissioner/Deputy collector/1st class stipendiary magistrate/Sub divisional Magistrate/Taluka Magistrate/Executive magistrate/Extra Assistant commissioner.
  - Chief Presidency magistrate/Additional chief presidency magistrate/Presidency magistrate.
  - Revenue Officer not below the rank of tehsildar.
  - Sub-Divisional officer of the area where the individual and / or his family normally resides.
- j. To avail the benefits of MSE under SC/ST category, the related documents as stated above should be submitted along with tender documents.
- k. Payment for MSE vendors will be as per MSMED Act, 2006.

## **5. RISK PURCHASE PENALTIES**

- a. In case of delay in delivery beyond PO delivery /mutually agreed delivery, or vendor fails /refuses to complete the PO as per terms, or insufficient facilities at vendor's works to execute a PO, BHEL has the right to get the items ordered elsewhere at the risk and cost of the vendor with notice to the vendor and the additional expenditure / difference in cost, if any, including consequential cost shall be recovered from the defaulted vendor. Also, in such case of withdrawal of orders, BHEL shall recover the additional expenditure / difference from vendor by adjusting against amount due to vendor and/or by invoking the BG and/or by any other suitable means as decided by BHEL. In addition, BHEL may recover from the defaulter vendor any loss to BHEL arising due to withdrawal of orders in such case, and action shall be taken as per latest revision of BHEL Guidelines for Suspension of Business dealings with Suppliers / Contractors.
- b. BHEL has the right to divert/cancel the order if the vendor has not procured minimum 50% of the quantity of raw materials within 60 days from PO date. Purchase order placed on steel mills and with proper payment voucher/proof will be considered for not cancelling the PO by BHEL. The submission of data by vendor for DB clearance by BHEL/QC shall be the proof of procurement. This is to avoid delay in project schedule due to delay in raw material procurement by vendors. In case the vendor fails to procure at least 50% of the quantity of raw materials within 60 days from PO date, BHEL has the right to get the items ordered elsewhere at the risk and cost of the defaulting Vendor and the additional expenditure / difference in cost, if any, including consequential cost shall be recovered from the defaulting Vendor and action shall be taken as per latest revision of BHEL Guidelines for Suspension of Business dealings with Suppliers / Contractors and SEARP.
- c. The defaulted vendor shall be liable for any loss, which BHEL may sustain by reason of such risk purchases in addition to liquidated damages as mentioned under LD clause.
- d. Vendors pending payments shall be withheld to cover the liabilities of BHEL towards risk purchase, if any.
- e. Reasons like power cut, labour issues, machine break down, etc. which are controllable by the sub-contractor shall not be accepted as reason for delay for delivery extension purposes.
- f. If PO delivery needs to be extended for reason attributable to BHEL, vendor may request BHEL in writing for delivery extension with justifications within 15 days from date of PO closure and before invoice.
- g. Process of calculating the risk and cost amount is as follows:  
Risk & Cost Amount=  $[(A-B) + (A \times H/100)]$   
Where,  
A= Value of Balance scope of Work/ Supply (\*) as per rates of new contract  
B= Value of Balance scope of Work/ Supply (\*) as per rates of old contract being paid to the contractor/ supplier at the time of termination of contract i.e. inclusive of PVC & ORC, if any.  
H = Overhead Factor to be taken as 5  
In case (A-B) is less than 0 (zero), value of (A-B) shall be taken as 0 (zero).  
\*(Balance scope of work/ supply)



# BHARAT HEAVY ELECTRICALS LTD

VALVES PURCHASE

Trichy - 620 014, India

GENERAL TERMS AND CONDITIONS

Enquiry Reference: **ENBPS02366**

Difference of Contract Quantities and Executed Quantities as on the date of issue of Letter for "Termination of Contract", shall be taken as balance scope of Work/ Supply for calculating risk & cost amount. Contract quantities are the quantities as per original contract. If, Contract has been amended, quantities as per amended Contract shall be considered as Contract Quantities. Items for which total quantities to be executed have exceeded the Contract Quantities based on drawings issued to contractor from time to time till issue of Termination letter, then for these items total Quantities as per issued drawings would be deemed to be contract quantities. Substitute/ extra items whose rates have already been approved would form part of contract quantities for this purpose. Substitute/ extra items which have been executed but rates have not been approved, would also form part of contract quantities for this purpose and rates of such items shall be determined in line with contractual provisions. In-case portion of work is being withdrawn, contract quantities pertaining to portion of work withdrawn shall be considered as 'Balance scope of work/supply' for calculating Risk & Cost amount.

- h. Vendors are cautioned that, withdrawal after price bid opening or after contract signing or PO/LOI acceptance will be construed as tampering with BHEL's tender process. Suitable action for suspension of further business with the vendor may be taken as per BHEL corporate procedures.
- i. Abridged version of extant 'Guidelines for suspension of business dealings with suppliers/ contractors' has now been uploaded on [www.bhel.com](http://www.bhel.com) on "supplier registration page" at the following link: [http://www.bhel.com/vender\\_registration/vender.php](http://www.bhel.com/vender_registration/vender.php) (Guidelines for suspension of business dealings with suppliers/ contractors).

## **6. GENERAL CONDITIONS**

- a. The manner of finalization will be as mentioned in the "Confirmation to the Terms and Conditions" attached. Separate orders will be released for each project and documents should be supplied for each order separately.
- b. BHEL reserves the right to reduce the tender quantity and to NOT to order for some or all material based on the changes in project.
- c. BHEL shall have the right to visit vendor works during the execution of contract along with end customer for verifying status, inspection and testing of the material.
- d. BHEL reserves the right to negotiate or re-float the tender in case the quoted prices are not acceptable.
- e. Supplier shall arrange packing to avoid lose or damages during Road Transport, Site handling & Storage.
- f. BHEL reserves the right to reject the offer of a particular bidder due to unsatisfactory past performance in the execution of a contract at any of BHEL projects / units.
- g. The Drawings and Technical documents given in this enquiry are the sole property of BHEL. This should not be misused in any form.
- h. Purchase Order, PO Item serial number, Material code, Quantity should be clearly marked on the packing
- i. Confirmation for compliance is to be given in the offer for all the conditions specified above and to the respective Purchase Specification.
- j. The bidder along with its associate/collaborators/sub-contractors/sub-vendors/consultants/service providers shall strictly adhere to BHEL fraud prevention policy (refer [www.bhel.com](http://www.bhel.com)) and shall immediately bring to the notice of the BHEL management about any fraud or suspected fraud as soon as it comes to their notice.
- k. For this procurement, Public Procurement (Preference to Make in India), Order 2017 dated 15.06.2017, 28.05.2018, 29.05.2019 and 04.06.2020, issued by DPIIT, Ministry of Commerce and Industry. If any subsequent Orders issued by the respective Nodal Ministry shall be applicable even if issued after issue of this NIT but before finalization of contract / PO / WO against this NIT. In the event of any Nodal Ministry prescribing higher or lower percentage of purchase and / or local content in respect of this procurement, same shall be applicable. Default purchase preference shall be 20% to local suppliers with default minimum local content of 50%.

## **7. DOCUMENTATION:**

- a. **With Consignment:** Duplicate for transporter copy, Original Invoice, Packing List, Delivery Challan, O&M manual (if applicable) Material Test Certificate, Test Certificates, Compliance Certificate, Guarantee/Warranty Certificate and other documents mentioned in PO/TDC/Drawing.
- b. **To Purchase:**



Maharatna Company

# BHARAT HEAVY ELECTRICALS LTD

## VALVES PURCHASE

Trichy - 620 014, India

### GENERAL TERMS AND CONDITIONS

Enquiry Reference: **ENBPS02366**

- i. FOR BHEL TRICHY case- Original Invoice, Duplicate for transporter copy, Packing list, LWB and Delivery challan, GST declaration as mentioned in point 3c.
- ii. FOR Site case- Original Invoice, Original LWB, Original Packing List, Original IBR documents, Original despatch clearance Certificate and Inspection report, Test certificates as per PO, Original Site Acknowledgment etc.
- c. **Identification:** Material code, Purchase Order, PO item serial number, Unique serial number if any should be provided in all despatch documents, materials and packing clearly.

#### 8. **TENDER EVALUATION:**

##### a. **Techno-commercial Bid.**

- i. All vendors should submit General arrangement drawing, datasheet and C&I diagram (if any) of the offered product
- ii. Point by point technical confirmation of all pages of our technical specifications and commercial conditions are required with your sign and seal along with techno commercial offer.
- iii. Offers from supplier not having technical capability or not agreed for commercial terms, will be rejected.

##### b. **Price Bid.**

- i. Bidders qualified for part I will be intimated for participating in priced bid opening.
- ii. L1 bidder will be decided based on landed cost for the equipment to BHEL.

##### **Indigenous Vendors**

Total Landed cost/rate for each item = FOR Rate in INR (A) + Applicable Taxes (B) + Loading non-acceptance of commercial terms (C) – Applicable input tax credit (D)

A - Indigenous vendors submit offers on Free on Road (FOR), Stores, HPBP BHEL Trichy in INR.

B - Applicable GST and any other charges quoted by indigenous vendors will be added to the base price.

C - Loading for non-acceptance of payment terms, delivery schedule & liquidated damages (LD) will be added to the F.O.R. value for arriving the landed rate.

D - However, input tax credit shall be availed for GST, hence the same is excluded for arriving at the landed cost.

##### iii. In case of tie for the L1 positions,

- a. In the course of evaluation, if more than one bidder happens to occupy L1 status, effective L1 will be decided by soliciting discounts from respective L1 bidders.
- b. In case more than one bidder happens to occupy the L1 status even after soliciting discounts, the L1 bidder shall be decided by a toss/draw of lots, in the presence of the respective L1 bidders(s) or their representative(s).
- c. Ranking will be done accordingly, BHEL's decision in such situation shall be final and binding.

#### Note:

All clarifications / issues shall be addressed directly to the tender issuing (procurement) department's officials whose contact details are provided below

(1)  
S Suresh  
Deputy Manager  
Valves Purchase  
24 Building, 3<sup>rd</sup> Floor,  
BHEL, Trichy-620014  
+91 431 2578668  
[suresh.s@bhel.in](mailto:suresh.s@bhel.in)

(2)  
Ajay Kumar Gupta  
AGM  
Valves Purchase  
24 Building, 3<sup>rd</sup> Floor,  
BHEL, Trichy-620014  
+91 431 2578156  
[ajaykumar.gupta@bhel.in](mailto:ajaykumar.gupta@bhel.in)

\*\*\*\*\*