

## Scope of Supply

Item no	Material Code	Material Description	DRG No/Rev No	TDC No/Rev No	Quantity (No)
10	964605980000	PACKING-DIA 100-ITEM 6-L972	3VL97222318/05	-	30
20	964605990000	PACKING-DIA 160-ITEM 6-L973	3VL97322318/05	-	30
30	964606040000	O RING-L975	3VL97522330/03	TDC:5:151/03	2
40	964606070000	O-RING-DIA 100-ITEM 27-L972	3VL97222331/03	TDC:5:151/03	10
50	964606080000	O-RING-DIA 160-ITEM 27-L973	3VL97322331/03	TDC:5:151/03	10
60	964606100000	O-RING-DIA 100-ITEM 29-L972	3VL97222332/03	TDC:5:151/03	10
70	964606110000	O-RING-DIA 160-ITEM 29-L973	3VL97322332/03	TDC:5:151/03	10
80	964606270000	SLIDE RING-DIA 100- ITEM 35-L972	3VL97222338/00	-	10
90	964606340000	SLIDE RING-L977	3VL97722339/00	-	5

Ref: ENSQN02348

Scope of Supply

100	964606350000	SLIDE RING-DIA 100- ITEM 34-L972	3VL97222340/00	-	10
110	964606360000	GASKET-DIA 100-ITEM 16-L972	3VL97222341/03	TDC:5:151/03	10
120	964606370000	GASKET-DIA 160-ITEM 16-L973	3VL97322341/03	TDC:5:151/03	10
130	964606380000	GASKET-L975	3VL97522341/03	TDC:5:151/03	2



Product: Elastomeric Compounds

Revision Record: Rev:00/16.04.90: First issue

Rev:01: 04.12.93: Editorial corrections

Rev:02: 15.11.96: Elastomer TDCs 5:131, 135,154,155,156,157,161,162,163,179,183 & 184 merged and rewritten

Rev.03: 12.08.21: Latest version of the referred Standards/Specifications indicated in TDC; Cl.4.0 & 8.0 modified

## 1.0 Material Specifications

Elastomer materials of grade specified in P.O.or drg. The property requirements are as given in Table-1.

### 2.0 General

These Elastomeric compounds are for use as O-rings/ packing in water and oil based drilling fluids, seawater, petroleum based lubricants and ethylene glycol anti-freeze mixtures. Shall be manufactured to the relevant size in the drawing.

The grade nos. specified correspond to the Standards of M/s National; USA.

### 3.0 Engineering Requirements

Material Properties: The property requirements for the elastomers are given in table-1.

The hardness tests shall be carried out as per ASTM D2240-15(Reapproved 2021) or ASTM D1415-18 and tensile tests as per ASTM D412-16(Reapproved 2021) or ASTM D1414-15 (as per ASTM D4894-19 for PTFE materials).

Additional property requirements for grades MS-447 & MS 452 (tested as per ASTM D621-88) are as follows.

	MS 447	MS 452
Coefficient of thermal expansion (in/in/ Fx10-5) at 75 to 300°F	6.0+ 0.5	7.6+0.5
% deformation under load (max.)(24 Hours at 2000 psi at 70°F Min).	5.0	3.5
% permanent deformation (max.) after load release	2.0	2.2

### 4.0 Inspection & Testing

Sampling inspection shall be carried out for visual, dimensions & hardness test as per Cl.8.0

Each piece of the sample shall be dimensionally inspected for compliance to specified tolerances in the relevant drawing.

Each piece of the sample shall be visually inspected for compliance to this specification.

The following type tests shall be carried out for conformance to this specification:

#### a) Air Aging Test:

This test shall be carried out in an Air oven as per ASTM D573-04(Reapproved 2019) or by heating in air in a test tube enclosure as per ASTM D865-11(Reapproved 2018). The purpose of this test is to determine the influence of elevated temperatures on the physical properties of vulcanized rubber.

The test shall be carried out at Minimum test temperature shown in table-2 for each grade for 70 hrs. in accordance with ASTM D412-16(Reapproved 2021) and properties after air aging test shall conform to table-2.

	<b>BHEL – Tiruchirappalli - 620014, India.</b> <b>Quality Assurance Department</b> <b>TECHNICAL DELIVERY CONDITIONS</b>	DOC No: <b>TDC:5:151</b> Rev: <b>03</b> Effective Date: <b>12/08/2021</b> Page: <b>2 of 6</b>
<b>Product: Elastomeric Compounds</b>		

**b) Compression Set Test :**

This test shall be carried out in accordance with ASTM D395-18 B i.e., Compression set under constant deflection in air with exceptions listed out in ASTM D1414-15 Cl.10.0.

The test shall be performed at a minimum test temperature indicated in table-2 for 70 hours, except for Grade MS 225. For grade MS:225, the test duration shall be 22 hours.

The maximum permanent compression set shall comply to table-2.

**c) Low Temperature Brittleness Test :**

This test ensures that rubber will not exhibit fracture when subjected to specified impact conditions. The Test shall be carried out in accordance with ASTM D2137-11(Reapproved 2018) or ASTM D746-20 and shall PASS at the test temperature indicated in table-2.

**d) Immersion Test :**

This test ensures the ability to withstand the effect of liquids and shall be carried out in accordance with ASTM D471-16a (Reapproved 2021) or ASTM D1414-15.

The liquids used for the test shall be ASTM Oil 1&3 at a minimum temperature indicated in Table-3 for various grades and Distilled water at a minimum temperature of 212°F for a period of 70 hrs. Permissible variation in properties after immersion in liquids are given in Table- 3.

Immersion test is not applicable for grades MS 447 & MS 452.

**Validity of Type Test:**

The validity of these Type test results is for two years from the date of test, in the case of PSL 1,2 & 3. However, in case of PSL 4, this test shall be carried out for each batch of purchase order. The type test shall be conducted at approved laboratory or witnessed by BHEL.

**5.0 Special Requirements**

Insert ring shall be positioned as shown in BHEL drawing or the drawing approved by BHEL.

After Moulding, all parts must be inspected by the vendor/manufacturer to ensure proper positioning of the insert ring. The NDE to be followed can be RT/MT and meet the requirement indicated in the drawing.

The ring must be generally located in the web of the seal, but in no case, in flexible lip of the seal. No part of the ring shall be visible to the naked eye unless it is specified in the drawings.

**6.0 Documentation**

For PSL 1,2 & 3: Certificate of compliance which indicates P.O.No, Drg No, Material grade & type tested compound no, Batchwise Cure/mould date & Shelf life(expiry date) shall be submitted.

For PSL 4 : Test certificates for the physical properties ,in addition to certificates mentioned above shall be submitted for each P.O.



Product: Elastomeric Compounds

### 7.0 Marking and Packing

Each item shall be packed in polythene cover individually with suitable preservatives like French chalk powder with label having following details.

- Dr. Number & size
- Purchase Order No.
- Batch Number
- Compound No.
- Date of Cure/Mould
- Shelf life (expiry date)
- Any other relevant details specified in the Purchase Order/drawing.

Each item shall be supplied in sturdy carton boxes to protect against permanent distortion during shipment and storage and from sunlight, dust etc. during shipment and storage.

Each box shall contain only one size and lot of the product as given below.

- Size more than 6" -- each separate box
- Size 2" to 6" -- 5 nos.in one box
- Size below 2" -- 10 nos.in one box.

Each box shall also be labeled with details specified above viz (a) to (g) above.

### 8.0 Sampling Plan:

Lot Size (Nos)	Sample size (Nos)	Acceptance Criteria for O-rings (as per ISO 2859-1:1999, Level II, 2.5 AQL)
26 to 50	8	If one sample fails, entire lot shall be dimensionally inspected
51 to 90	13	If two samples fail, entire lot shall be dimensionally inspected
91 to 150	20	
151 to 280	32	If three samples fail, entire lot shall be dimensionally inspected
281 to 500	50	If four samples fail, entire lot shall be dimensionally inspected

Lot Size (Nos)	Sample size (Nos)	Acceptance Criteria for other seals (as per ISO 2859-1:1999, Level II, 1.5 AQL)
26 to 50	8	If one sample fails, entire lot shall be dimensionally inspected
51 to 90	13	
91 to 150	20	If two samples fail, entire lot shall be dimensionally inspected
151 to 280	32	
281 to 500	50	If three samples fail, entire lot shall be dimensionally inspected

For lot size 25 Nos. & below, 100% inspection shall be done

 N Nagamuthu Pandian Manager/QA	 P Arun kumar Dy. Manager / Valves Engg	 S. Lakshmi SDGM/QA	 Ajay Kumar Gupta AGM / Valves Purchase	 J V Aruna Kumar AGM / QA
<b>Prepared By</b>	<b>Reviewed By</b>		<b>Approved By</b>	

	<b>BHEL – Tiruchirappalli - 620014, India.</b> <b>Quality Assurance Department</b> <b>TECHNICAL DELIVERY CONDITIONS</b>	DOC No: <b>TDC:5:151</b> Rev: <b>03</b> Effective Date: <b>12/08/2021</b> Page: <b>4</b> of <b>6</b>
	<b>Product: Elastomeric Compounds</b>	

**TABLE-1 PROPERTY REQUIREMENT OF ELASTOMERS**

Elastomer Grade		MS 219	MS 220	MS 221	MS 225	MS 231	MS 233	MS 426	MS 427	MS 428	MS 430	MS 431	MS 447	MS 452
Material		NBR	NBR	NBR	NBR	FKM	FKM	TFEP	TFEP	FVMQ	HSN	XNBR	PTFE	PTFE
Hardness	Value	60±5	70±5	90±5	70±5	90±5	70±5	90+10 -5	80±5	85±5	80±5	70±5	65±5	63±5
	Type	(A)	(A)	(A)	(A)	(A)	(A)	(A)	(A)	(A)	(A)	(A)	(D)	(D)
Applicable Temperature Range °F	Min.	0	-20	-20	32	0	-20	-20	-20	-50	-20	-20	-50	-50
	Max.	180	180	180	200	250	250	250	250	250	250	180	250	250
Tensile strength in psi (min)		2000	2000	2500	2000	1600	1500	2200	2000	1000	2500	2000	1500	1000
Ultimate elongation % (min)		500	300	200	350	100	100	100	100	150	150	300	75	75
Tensile modulus (psi)at 100% elongation (min)		200	400	800	600	500	500	-	1000	500	500	400	-	-
Tensile modulus (psi)at 50% elongation (min)		-	-	-	-	-	-	1500	-	-	-	-	-	-
Shelf life in years		2	2	2	2	4	4	4	4	4	2	2	10	10
NBR - Nitrile TFEP - Tetra fluoro ethylene & Propylene(AFLAS) PTFE - Teflon (W/Ryton/MoS2/Carbon filler)-MS452		FVMQ - Fluoro Silicone (Silastic LS)					FKM - Fluoro carbon(VITON,FLUOREL)				HSN - Hydrogenated Nitrile			
							XNBR - Carboxylated Nitrile				PTFE - Teflon (W/25% carbon/graphite filler)-MS447			

**TABLE-2 : AIR AGING, COMPRESSION AND LOW TEMPERATURE BRITTLINESS TEST REQUIREMENTS**

Grade	Minimum Temperature °F(*)	Air Aging Test Acceptable variation in				Compression test result (Compression set) in (%)max	Test Temperature for Low Temperature Brittleness Test
		Hardness points	Tensile Strength(%)	Ultimate Elongation(%)	Volume(%)		
MS 219	180	±05	±10	±20	±10	40	0°F
MS 220	180	±10	±15	±20	±05	30	0°F&-20°F
MS 221	180	±05	±10	±30	±10	25	0°F&-20°F
MS 225	212	±10	±10	±20	±10	40	32°F
MS 231	250	±10	-40max	-20max	±10	40	0°F
MS 233	250	±10	-40max	-20max	±10	40	0°F&-20°F
MS 426	250	±10	±10	±15	±10	30	0°F&-20°F
MS 427	250	±10	-25	-25	-	40	0°F&-20°F
MS 428	250	±05	±10	±10	±10	30	0°F, -20°F, -50°F&-75°F
MS 430	250	±10	±10	±20	±10	30	0°F&-20°F
MS 431	180	±05	±15	±20	±10	35	0°F&-20°F
MS 447	-	-	-	-	-	-	0°F, -20°F & -50°F
MS 452	-	-	-	-	-	-	0°F, -20°F & -50°F

(\*) Min. test temperature is same for both air aging test & compression test

**TABLE-3 : IMMERSION TEST REQUIREMENT**

Grade	Minimum Temperature °F(*)	Permissible variation in properties (±) with											
		ASTM Oil # 1				ASTM Oil # 3				Distilled Water			
		Hardness	Tensile strength	Ultimate Elongation	Volume	Hardness	Tensile strength	Ultimate Elongation	Volume	Hardness	Tensile strength	Ultimate Elongation	Volume
MS219	180	05	10	20	10	10	20	15	20	05	15	20	10
MS220	180	10	20	20	10	10	20	20	10	10	20	20	10
MS221	180	05	15	30	10	05	15	30	10	05	15	10	05
MS225	212	05	05	10	05	05	05	10	10	-	-	-	-
MS231	250	05	15	10	05	05	10	10	05	05	20	10	10
MS233	250	05	15	10	05	05	10	10	05	05	20	10	10
MS426	250	10	15	20	10	10	15	20	20	10	15	20	10
MS427	250	05	15	25	10	10	20	25	10	05	15	20	10
MS428	250	05	15	10	10	10	20	10	30	05	10	10	10
MS430	250	10	10	20	10	10	10	20	10	05	10	10	10
MS431	180	10	20	20	10	10	20	20	10	-	-	-	-

\*Minimum test temperature specified is only for immersion test with ASTM Oil #1 & 3. For distilled water, the test temp. is 212°F.

NOTE: Values indicated in Table are % values, except for Hardness. For hardness, it is variation in absolute value.

3-V-0000-22318  
DRAWING NO.

6

NOTE

1. COMPRESSED GRAFOIL RINGS WITH ZINC DUST CORROSION INHIBITOR TO BE COMPRESSED TO DENSITY OF 1.6 gm/cc TO 1.8 gm/cc
2. CORROSION INHIBITOR - ZINC - 2% (MINIMUM)
3. SULPHUR COMPOUNDS EXPRESSED AS 'S' - 100 PPM (MAXIMUM)
4. LEACHABLE CHLORIDE CONTENT NOT TO EXCEED 50 PPM.
5. ASH CONTENT CONSISTING OF TRACE ELEMENTS IN OXIDE FORM MAX 2%.
6. RINGS SHALL BE IN ENDLESS FORM.
7. LATEST APPLICABLE QUALITY PROCEDURE SHALL BE FOLLOWED IN ALL RESPECTS.

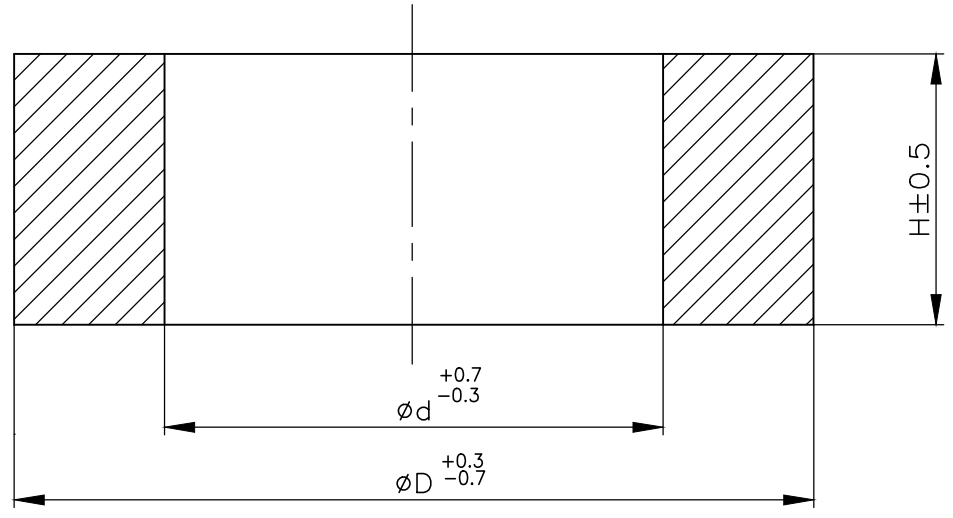

04	3-V-L977-22318/05	54	40	7	15.80	964606010000	$\phi 220, \phi 250$
03	3-V-L975-22318/05	48	34	7	13.44	964606000000	$\phi 200$
02	3-V-L973-22318/05	44	30	7	12.10	964605990000	$\phi 160$
01	3-V-L972-22318/05	32	20	6	4.87	964605980000	$\phi 100$
SL.No	DRAWING No	$\phi D$	$\phi d$	H	WT (gms)	MATL.CODE	CYL.SIZE
		DIMENSIONS					

NO OFF	DESCRIPTION	MATL CODE	MATL SPECN	HEAT TREATMENT	SCRAP SORT	NET WT (kg)	GROSS WT (kg)	DRAWING No	ITEM No
--------	-------------	-----------	------------	----------------	------------	-------------	---------------	------------	---------

TYPE OF PRODUCT OR NAME OF CUSTOMER/PROJECT: **QN**

BHARAT HEAVY ELECTRICALS LTD., UNIT: HIGH PRESSURE BOILER PLANT. TIRUCHIRAPALLI-620014.	DRN	M.KARTHIK	SIGN	M.KARTHIK	DATE	25.06.10	NO.OF VAR.
	CHD	JALAL	JALAL	25.06.10			
	APPD	PRK	PRK	25.06.10			

DEPT VL	SCALE	WEIGHT (KG)	REFERENCE INFORMATION	NO. OF ITEMS
CODE 320	N.T.S	-		
TITLE	CARD CODE	DRAWING NO.	REV	
PACKING (GRAFOIL)	U 01	3-V-0000-22318	05	

REV	DATE	ALTERED	JALAL
05	01.04.14	CHD & APPD	SAKETH

NOTES UPDATED FOR ZINC CONTENT.

CAUTION: The information on this document is the property of BHARAT HEAVY ELECTRICALS LTD. It must not be used directly or indirectly in any way detrimental to the interest of the company.

3-V-0000-22331  
DRAWING NO.

SL.NO.	DRAWING NO.	COMPONENT CODE	MATL. SPEC.	DIMENSIONS		FOR REFERENCE		WEIGHT IN Kgs.
				∅d	W	AS PER JIS B2401	CYLINDER SIZE	
01	3-V-L972-22331/03	96 460 607 0000	VITON FKM 90±5 (NOTE-2)	±0.12 17.8	±0.07 2.4	P18	∅100	0.003
02	3-V-L973-22331/03	96 460 608 0000		±0.15 25.7	±0.1 3.5	P26	∅160	0.009
03	3-V-L977-22331/03	96 460 609 0000		±0.15 29.4	±0.1 3.1	G30	∅200 ∅220,∅250	0.008
04	3-V-L981-22331	96 460 873 0000		±0.15 31.7	±0.1 3.5	P32	200	0.010
05	3-V-L983-22331	96 462 026 0000		±0.15 34.7	±0.1 3.5	P35	∅250	0.012

**NOTES**

- HARDNESS AS PER LATEST APPLICABLE QUALITY PROCEDURE.
- MATERIAL SHALL COMPLY WITH REQUIREMENTS OF LATEST APPLICABLE QUALITY PROCEDURE.
- SURFACE FINISH SHOULD BE SMOOTH
- EACH O-RING SHALL BE MARKED WITH PERMENENT INK DIMENSIONS ∅d & W(SEE TABULATION)
- O-RING SHALL BE PACKED AS PER LATEST APPLICABLE QUALITY PROCEDURE.
- P MEANS DYNAMIC O-RING & G MEANS STATIC O-RING

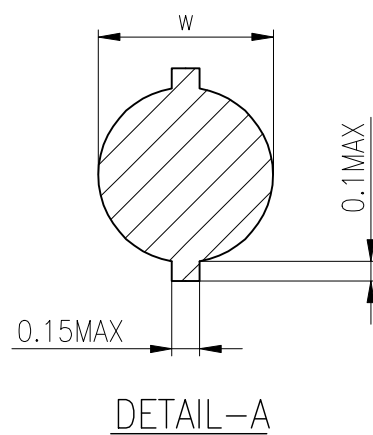
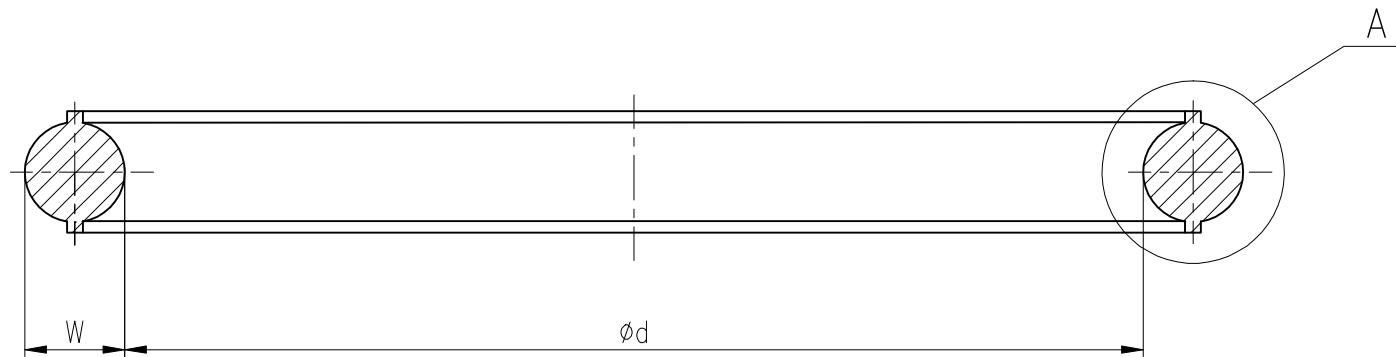

REV	DATE	ALTERED	JALAL
05	04.02.12	CHD & APPD	P.R.K

DRAWING REDRAWN IN ACAD  
SL.NO. 05 ADDED.

CAUTION: The information on this document is the property of BHARAT HEAVY ELECTRICALS LTD. It must not be used directly or indirectly in any way detrimental to the interest of the company.

NO OFF	DESCRIPTION	MATL CODE	MATL SPECN	HEAT TREATMENT	SCRAP SORT	NET WT (kg)	GROSS WT (kg)	DRAWING No	ITEM No			
TYPE OF PRODUCT OR NAME OF CUSTOMER/PROJECT												
365-121				BHARAT HEAVY ELECTRICALS LTD., UNIT: HIGH PRESSURE BOILER PLANT. TIRUCHIRAPALLI-620014.		DRN	JALAL	SIGN	JALAL	DATE	06.02.12	NO.OF VAR.
DEPT VL				SCALE		WEIGHT (KG).		REFERENCE INFORMATIONS			NO. OF ITEMS	
CODE 320				NTS		REF. TABLE		DRAWING NO.			REV	
TITLE						CARD CODE		DRAWING NO.		REV		
'O' RING						U 01		3-V-0000-22331		05		

FOR TOLERANCES OF TOLERANCED DIMENSIONS DURING MANUFACTURE REFER RELEVANT DCP/OP.

ALL DIMENSIONS ARE IN MILLIMETRES

SLNO	DRAWING NO	MATL.CODE	MATL.SPECN	NET WT (kg)	DIMENSIONS		AS PER JIS B2401	FOR REFERENCE CYLINDER SIZE
					φd	W		
01	3-V-L972-22330/0.3	96 460 602	VITON FKM 9015 (NOTE-2)	0.008	89.6±0.4	5.7±0.15	P90	φ100
02	3-V-L973-22330/0.3	96 460 603		0.014	149.6±0.6	5.7±0.15	P150	φ160
03	3-V-L975-22330/0.3	96 460 604		0.038	184.5±0.8	8.4±0.15	P185	φ200
04	3-V-L976-22330/0.3	96 460 605		0.042	204.5±0.8	8.4±0.15	P205	φ220
05	3-V-L977-22330/0.3	96 460 606		0.048	234.5±0.8	8.4±0.15	P235	φ250

14

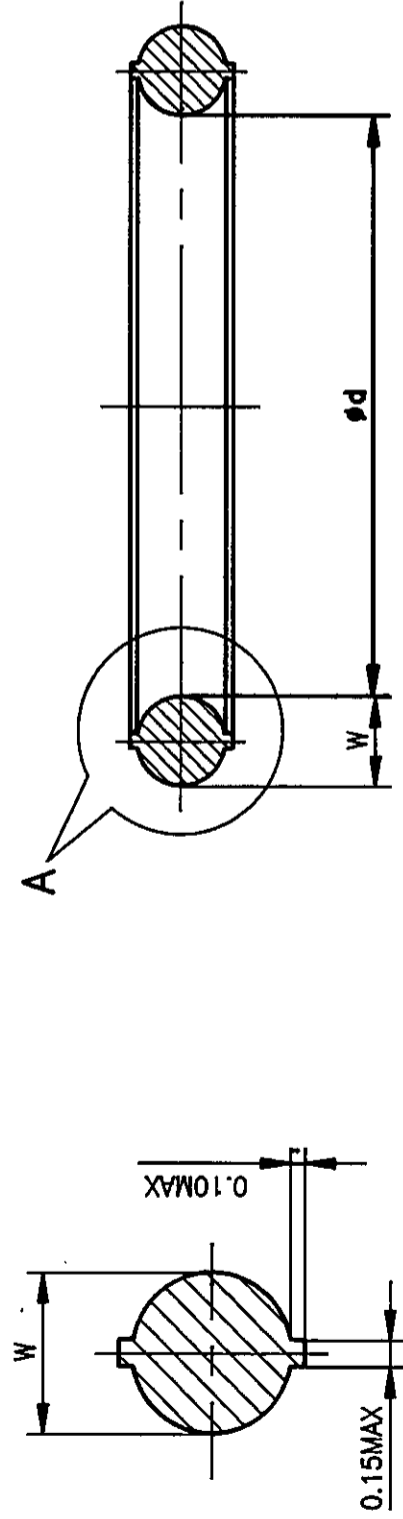

DETAIL-A

NOTES:

1. HARDNEES : AS PER T.D.C
2. MATERIAL SHALL COMPLY WITH REQUIREMENTS OF LATEST APPLICABLE QUALITY PROCEDURE.
3. SURFACE FINISH SHOULD BE SMOOTH
4. EACH O-RING SHALL BE MARKED WITH PERMANENT INK DIMENSIONS φd & W(SEE TABULATION)
5. O-RINGS SHALL BE PACKED AS PER LATEST APPLICABLE QUALITY PROCEDURE.

REV DATE	03 30.4.97	ALTERED: PRK. M. R.
MATL. SPECN.	VITON FKM 9015 (NOTE-2)	
WAS VITON.		
REV DATE	01 18/1/94	ALTERED: MPS m/s
REV DATE	02 16/11/96	ALTERED: PRK. M. R.
REV DATE	01 18/1/94	CHECKED: SCS m/s
LATEST REVISION MARKED IN TDC 5:155		
NOTES UPDATED		
DCN:QN:0454		

CAUTION: The information on this document is the property of BHARAT HEAVY ELECTRICALS LTD. It must not be used directly or indirectly in any way detrimental to the interest of the company.

TYPE OF PRODUCT OR NAME OF CUSTOMER/PROJECT



BHARAT HEAVY ELECTRICALS LTD.,  
UNIT: HIGH PRESSURE BOILER PLANT,  
TIRUCHIRAPALLI-620014.

DEPT  
CODE  
TITLE

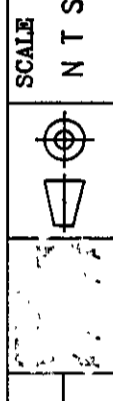

SCALE  
N T S

WEIGHT(KG)

CARD CODE  
U 01

O-RING (DYNAMIC)

DRAWING NO.  
3-V-0000-22330 03

REV



NAME	SIGN	DATE	NO. OF VAR.
MPS	m/s		
SCS	m/s		
SK	m/s	14/12/91	
COMP CODE			
ITEM NO.			
NO. OF PAGES			



SLNO	DRAWIING NO	MATL.SPECN	MATL.CODE	DIMENSIONS			NET WT(kg)	CYLINDER SIZE	FOR REFERENCE PART NO.AS PER WIS.SHAMBAN CO.LTD.
				t	h	l			
01	3-V-L972-22338	CARBON-PTFE (TURCITE10)	96 460 627	2	7.9	68	0.0012	Ø100	S-55858-300-10A
02	3-V-L973-22338	CARBON-PTFE (TURCITE10)	96 460 628	2	7.9	98	0.0018	Ø160	S-55858-300-10A
03	3-V-L975-22338	CARBON-PTFE (TURCITE10)	96 460 629	2	7.9	111	0.002	Ø200	S-55858-340-10A
04	3-V-L977-22338	CARBON-PTFE (TURCITE10)	96 460 630	2	7.9	130	0.0025	Ø220 Ø250	S-55858-300-10A

35

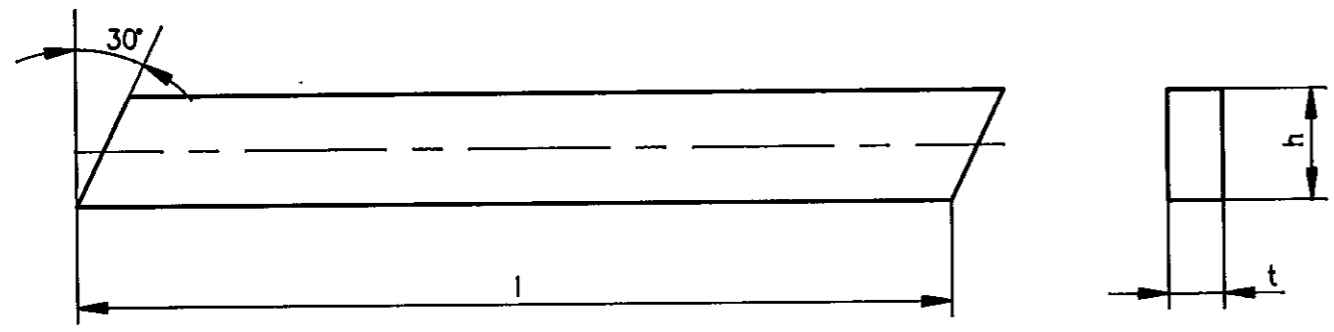

REV	DATE	ALTERED
		CHECKED

CAUTION: The information on this document is the property of BHARAT HEAVY ELECTRICALS LTD. It must not be used directly or indirectly in any way detrimental to the interest of the company.

TYPE OF PRODUCT OR NAME OF CUSTOMER/PROJECT		BHARAT HEAVY ELECTRICALS LTD. UNIT: HIGH PRESSURE BOILER PLANT. TIRUCHIRAPALLI-620014.		DRN	NAME	SIGN	DATE	NO.OF VAR.
DEPT		GRADE	SCALE	CHD	SCS	<i>B. Ch.</i>	6.11.91	
CODE		UNTOL.DIM	WEIGHT(KG)	APPD	SK	<i>Man</i>	14/12/91	
TITLE		COMP CODE	DRAWING NO.	REV				
SLIDE RING (CARBON-PTFE TURCITE 10)		U 01	3-V-0000-22338					

ALL DIMENSIONS ARE IN MILLIMETRES

34

SLNO	DRAWING NO	MATL.SPECN	MATL.CODE	DIMENSIONS		NET WT	CYLINDER SIZE	FOR REFERENCE PART NO.AS PER WIS.SHAMBAN CO.LTD.
				t	h			
01	3-V-L973-22339	BRONZE-PTFE (TURCITE47)	96 460 631	2.5	9.5	0.014	φ160	S-55909-1605.2-47A
02	3-V-L975-22339	BRONZE-PTFE (TURCITE47)	96 460 632	2.5	9.5	0.0176	φ200	S-55909-2006.8-47A
03	3-V-L976-22339	BRONZE-PTFE (TURCITE47)	96 460 633	2.5	9.5	0.019	φ220	S-55909-2206.8-47A
04	3-V-L977-22339	BRONZE-PTFE (TURCITE47)	96 460 634	2.5	9.5	0.022	φ250	S-55909-2506.8-47A

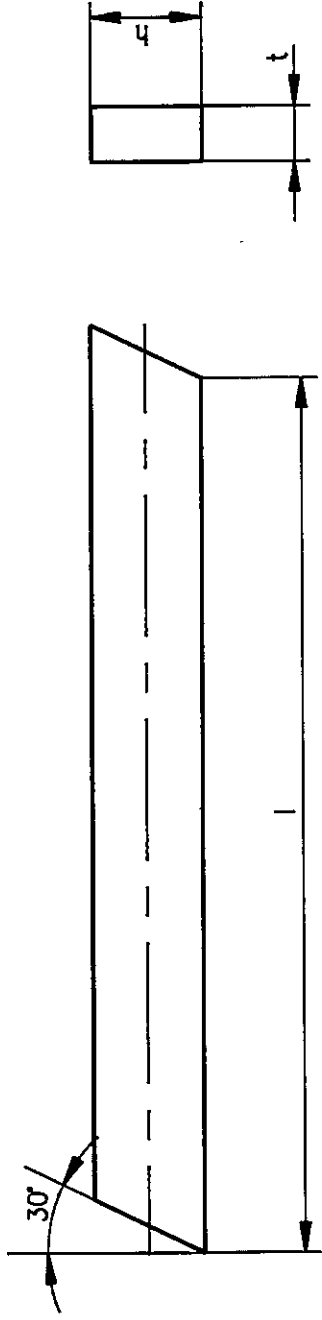

TYPE OF PRODUCT  
OR NAME OF  
CUSTOMER/PROJECT

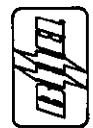

**BHARAT HEAVY ELECTRICALS LTD.,**  
UNT: HIGH PRESSURE BOILER PLANT.  
TIRUCHIRAPPALLI-620014.

DEPT  
GRADE  
UNTOL.DIM  
β / M / F

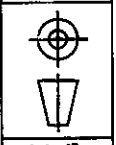

SCALE  
N T S

WEIGHT(KG)

COMP CODE

DATE  
6.11.91

SIGN  
B. CHEZHIAN

DRN  
B. CHEZHIAN

NO. OF VAR

CHD  
SCS

APPD  
SK

ITEM NO.

141241

NO. OF SHEET

REV

DRAWING NO.  
3-V-0000-22339

CARD CODE  
U 01

TITLE  
SLIDE RING  
(BRONZE-PTFE TURCITE 47)

CAUTION: The information on this document is the property of BHARAT HEAVY ELECTRICALS LTD. It must not be used directly or indirectly in any way detrimental to the interest of the company.

REV	DATE	ALTERED
		CHECKED

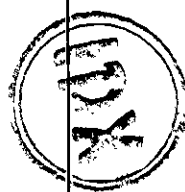

34

SLNO	DRAWING NO	MATL.SPECN	MATL.CODE	DIMENSIONS		NET WT	CYLINDER SIZE	FOR REFERENCE PART NO.AS PER WIS.SHAMBAN CO.LTD.
				t	h			
01	3-V-L972-22340	BRONZE-PTFE (TURCITE)	96 460 635	2	7.9	0.005	φ100	S-55858-300-10A

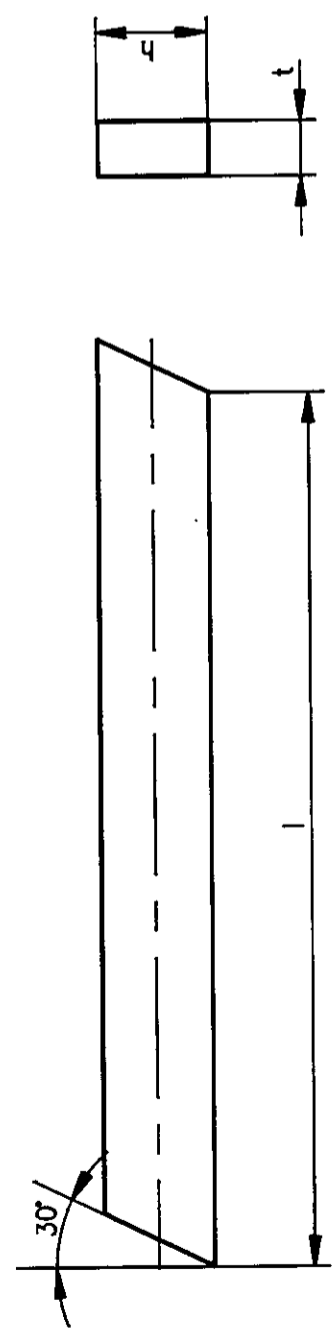

TYPE OF PRODUCT OR NAME OF CUSTOMER/PROJECT		BHARAT HEAVY ELECTRICALS LTD., UNT: HIGH PRESSURE BOILER PLANT. TIRUCHIRAPALLI-620014.		DRN	NAME	SIGN	DATE	NO.OF VAR
				CHD	B.CHEZHIAN	B.ch	6.11.91	
				APPD	SCS	M		
					SK	B	14/12/91	
DEPT	GRADE	UNVOL.DIM	SCALE	WEIGHT(KG)		NO. OF ITEM		
	φ / M / F		N T S					
TITLE				CARD CODE		REV		
SLIDE RING (BRONZE-PTFE TURCITE-10)				U 01		3-V-0000-22340		

CAUTION: The information on this document is the property of BHARAT HEAVY ELECTRICALS LTD. It must not be used directly or indirectly in any way detrimental to the interest of the company.

REV	DATE	ALTERED
		CHECKED

16

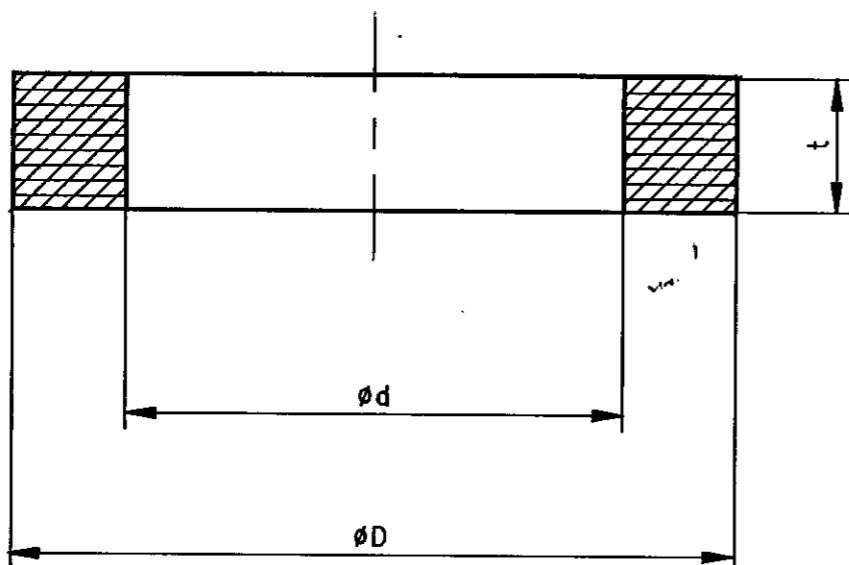

**NOTE**

- 01.HARDNESS AS PER LATEST APPLICABLE QUALITY PROCEDURE
- 02.MATERIAL SHALL COMPLY WITH REQUIREMENTS OF LATEST APPLICABLE QUALITY PROCEDURE.
- 03.SURFACE FINISH SHOULD BE SMOOTH
- 04.GASKETS SHALL BE MARKED WITH PERMANENT INK DIMENSIONS øD X ød X T
- 05.GASKETS SHALL BE PACKED AS PER LATEST APPLICABLE QUALITY PROCEDURE

SL NO	DRAWING NO	øD	ød	t	NET WT(Kg)	COMPONENT CODE	MATERIAL SPECIFICATION	CYL.SIZE
05	3-V-L977-22341/03	284	231	3	0.077	964606400000	VITON FKM 70±5	ø250
04	3-V-L976-22341/03	254	201	3	0.068	964606390000		ø220
03	3-V-L975-22341/03	230	179	3	0.059	964606380000		ø200
02	3-V-L973-22341/03	189	146	3	0.04	964606370000		ø160
01	3-V-L972-22341/03	121	93	3	0.017	964606360000		ø100

REV	DATE	ALT: PRK. M. H. L.
03	30.4.97	CHD & APPD: SCS M. H. L.

MATERIAL SPECIFICATION GIVEN.

DCN:QN:0513

REV	DATE	ALTD: PRE: M. H. L.
02	16.11.96	CHD APPD SCS M. H. L.

NOTES UPDATED.

DCN/QN:0454

REV	DATE	ALTERED MFS M. H. L.
01	18/1/94	CHECKED SCS M. H. L.

LATEST REVISION MARKED IN TDC 5:155

DCN:QN:0238

CAUTION: The information on this document is the property of BHARAT HEAVY ELECTRICALS LTD. It must not be used directly or indirectly in any way detrimental to the interest of the company.

TYPE OF PRODUCT OR NAME OF CUSTOMER/PROJECT



**BHARAT HEAVY ELECTRICALS LTD.,**  
UNIT: HIGH PRESSURE BOILER PLANT.  
TIRUCHIRAPALLI-620014.

DRN	NAME	SIGN	DATE	NO. OF VAR.
CHD	S.C S	M. H. L.		
APPD	S.K	M. H. L.	14/12/91	

DEPT	GRADE UNTOL DIM	SCALE	WEIGHT(KG)	COMP CODE	ITEM NO.	NO. OF ITEMS
	G / M / F	NTS				
TITLE	CARD CODE	DRAWING NO.	REV			
GASKET (VITON)	U 01	3-V-0000-22341	03			



# BHARAT HEAVY ELECTRICALS LTD

VALVES PURCHASE

Trichy - 620 014. India

CONFIRMATION TO TERMS AND CONDITIONS

**Enquiry Reference:** ENSQN02348

<b><u>TERMS &amp; CONDITION</u></b>	<b><u>VENDOR CONFIRMATION</u></b>
<p><b>a. Vendor Quotation Ref No and Date</b></p>	
<p><b>b. Pre-Qualification Requirement</b></p> <p>Vendor to furnish records of previous supplies of same or similar category items to any Central / State Govt Organization / PSU / Public Listed Company: To fulfil this criteria vendor shall submit previous records not more than 5 years old from date of part 1 bid opening.</p>	
<p><b>c. Vendor should give confirmation to BHEL's Technical Specification. To fulfil this criteria vendor shall submit the specification duly sealed and signed.</b></p> <p>Any deviations from the specification are to be furnished separately as "Schedule of Deviation".</p> <p>If there is no deviation vendor should indicate <b>"No Deviation"</b>.</p>	
<p><b>d. The offer has to be submitted as a <b>Two-part bid</b> (Techno-commercial &amp; Price bid)</b></p>	
<p><b>e. The tender will be finalized on item wise basis</b></p>	
<p><b>f. Terms of Payment:</b></p> <p><u>Indigenous Supplier (Non-MSE):</u> 100% direct EFT Payment after 60 days from the date of receipt and acceptance of materials at BHEL stores / against site acknowledgement.</p> <p><u>Indigenous Supplier (MSE):</u> Payment will be as per MSMED Act, 2006. (Udyam Registration Certificate to be enclosed along with the offer)</p>	
<p><b>g. Liquidated Damage:</b> Liquidated damages shall be 0.5% of the undelivered portion per week of the delay or part thereof subject to a maximum of 10% of the total order value.</p>	
<p><b>h. Delivery Terms:</b></p> <p>Prices shall be quoted on "<b>FIRM PRICE</b>" basis only.</p> <p><u>For Indigenous Supplies:</u> FOR BHEL Trichy</p>	
<p><b>i. Validity of Offer:</b> Prices should be valid for 60 days from the date of part-1 bid opening of this tender. The delay in responding to BHEL technical clarification beyond four days will be subsequently added to the validity period, Revised Price Bids will not be encouraged.</p>	
<p><b>j. Delivery period:</b></p> <p>Delivery period should be <b>8 weeks</b> from the date of purchase order.</p> <p>If supplier offers more than the required delivery period BHEL will operate 0.5% loading factor for evaluation of their offer for every week delay subject to a maximum of <b>2%</b>. Any other delivery period after loading to maximum will be rejected.</p>	
<p><b>k. Risk Purchase:</b></p> <p>Risk purchase penalties as per clause 5 of general terms and conditions is applicable for this enquiry. Non acceptance to risk purchase clause the offer is liable for rejection.</p>	



# BHARAT HEAVY ELECTRICALS LTD

VALVES PURCHASE

Trichy - 620 014. India

CONFIRMATION TO TERMS AND CONDITIONS

**Enquiry Reference:** ENSQN02348

<b><u>TERMS &amp; CONDITION</u></b>	<b><u>VENDOR CONFIRMATION</u></b>
<b>l. Guarantee Clause:</b> The vendor shall give a guarantee for the performance of his supplies for a period of eighteen months from the date of dispatch or twelve months from the date of commissioning whichever is earlier.	
<b>m. Performance Bank Guarantee:</b> Performance Bank Guarantee is not applicable for this enquiry	
<b>n. Counter-offering</b> Counter-offering is not applicable for this enquiry	
<b>o. Integrity Pact</b> Integrity pact is not applicable for this enquiry	



# BHARAT HEAVY ELECTRICALS LTD

VALVES PURCHASE

Trichy - 620 014, India

GENERAL TERMS AND CONDITIONS

Enquiry Reference: **ENSQN02348**

## 1. QUOTATIONS:

### a. BID system:

- i. Two part bid: The offers are invited in Two part bid system (Part I will be Techno-commercial bid and part II will be Price Bid). Techno-commercially suitable vendors alone will be intimated for price bid opening.

### b. Submission of offer:

- i. Offer called through e-Procurement mode: The bidder shall submit the bid online in BHEL e-Procurement portal at <https://eprocarebhel.co.in/>

The bidder would be required to register on the above e-procurement portal for submitting their bids. Offers through email and hardcopy are not acceptable.

- c. **Regulations**: Offers should be free from correction and erasures. Corrections if any must be attested. All amounts shall be indicated both in words as well as figures. In case of a difference between the amount quoted in words and figures, the amount quoted in words shall prevail.
- d. **PVC**: Price Variation clause not acceptable. Prices should be firm.
- e. **Catalogue**: Manufacturer's name, Trade Mark or Patent No. if any should be specified. Illustrative leaflets giving technical particulars are required along with quotation.
- f. **Samples**: Samples should be submitted separately, if specially requested in tender, before the due date of the enquiry. They should be clearly marked with the enquiry reference and date on the enclosing cover to facilitate identification.
- g. **GST Number**: GST registration number, HSN number (Item wise) with applicable taxes should be mentioned in the offer. If the vendor is not GST registered the offer is liable for rejection.
- h. **Deviation**. Any deviations from the specification are to be furnished separately as "Schedule of Deviation". If there is no deviation, vendor should indicate "No Deviation" in the offer.
- i. **Confirmation**: Confirmation for compliance is to be given in the offer for all the techno commercial conditions specified in the tender.

## 2. COMMERCIAL TERMS & CONDITIONS:

### a. Terms of Payment:

#### **For Indigenous Suppliers:**

If the materials are receivable at BHEL Stores, Trichy:

Payment term is 100% direct Payment after 60 days from the date of receipt and acceptance of materials.

Any deviation in the above payment terms, any other conditions in payment terms or any other payment terms will not be accepted and offers will not be considered.

**For New Suppliers:** For new suppliers not registered with BHEL, Trichy for the product, payment shall be made 60 days after receipt and acceptance of materials.

- b. **Liquidated Damage**: Liquidated damages shall be 0.5% of the undelivered portion per week of the delay or part thereof subject to a maximum of 10% of the total order value.

Any deviation from the above LD clause, loading will be applied to the extent to which it is not agreed by the bidder (at offered value)

Under GST regime, BHEL has to discharge GST liability on LD recovered from suppliers. Hence applicable GST shall also be recoverable from suppliers on LD amount. Debit note will be issued by BHEL for this amount, indicating the respective supply invoice number.

### c. Delivery Terms:

For Indigenous Suppliers: FOR BHEL Trichy inclusive of freight and insurance

- d. **Validity of Offer**: Prices should be fixed and should be valid for period as mentioned in the "Confirmation to the Terms and Conditions" attached.
- e. **Delivery period**: Delivery schedule will be as mentioned in the "Confirmation to the Terms and Conditions" attached. If supplier offers more than the required delivery period BHEL will operate 0.5% loading factor for evaluation of their offer for every week delay.



# BHARAT HEAVY ELECTRICALS LTD

## VALVES PURCHASE

Trichy - 620 014, India

### GENERAL TERMS AND CONDITIONS

Enquiry Reference: **ENSQN02348**

- f. **Guarantee period:** The vendor shall give a guarantee for the performance of his supplies for a period of **eighteen months** from the date of dispatch or **twelve months** from the date of commissioning whichever is earlier.
- g. **Miscellaneous:** Any conditions which might have been quoted by the seller and are in contravention to the terms of PO and which have not been specifically accepted by Purchaser will not be applicable to the contract/PO.
- h. **Performance Bank Guarantee:** If tender calls for Performance Bank Guarantee, vendor should provide a performance bank guarantee (PBG) in BHEL format for 10% of the total Purchase order value valid for warranty/guarantee period with an additional claim period of 2 months. PBG should be issued from list of consortium banks.
- i. **Counter Offering:** If counter offering is applicable for the enquiry, the L1 rates will be counter-offered to other eligible vendors as per below points
  - In case there are only two qualified offers for any item, the L1 rate will be counter-offered to the L2 vendor.
  - In case of more than two qualified offers for any item, the L1 rates will be counter-offered to maximum (n-1) vendors (where 'n' is the no. of techno-commercially qualified vendors) or the no. of vendors required (as mentioned in the "Confirmation to the Terms and Conditions" attached), whichever is lower.
  - In case a lower ranked vendor does not accept the counter-offered rates, the rates may be offered to next higher ranked vendor.
  - The manner of splitting of the enquiry quantity across L1 and counter-offer accepted vendors will be as per the ratios mentioned in the "Confirmation to the Terms and Conditions" attached.

### **3. COMPLIANCE / ACCEPTANCE REQUIRED FOR FOLLOWING POINTS TO ENSURE INPUT TAX CREDIT**

- a. Response to Tenders for Indigenous supplier/Vendor will be entertained only if the vendor has a valid GST registration No (GSTIN) which should be clearly mentioned in the offer. If the Vendor is exempted from GST registration, a declaration with due supporting documents need to be furnished for considering the offer. Vendor under composition scheme should declare that he is a composition Vendor supported by the screen shot taken from GST portal. The dealer has to submit necessary documents if there is any change in status under GST.
- b. Supplier shall mention their GSTIN in all their invoices (incl. credit Notes, Debit Notes) and invoices shall be in the format as specified/prescribed under GST laws. Invoices shall necessarily contain Invoice number (in case of multiple numbering system is being followed for billing like SAP invoice no, commercial invoice no etc., then the Invoice No. which is linked/uploaded in GSTN network shall be clearly indicated), Billed to party (with GSTIN) & Shipped to party details, item description as per PO, Quantity, Rate, Value, applicable taxes with nomenclature (like IGST, SGST, CGST & UTGST) separately, HSN/ SAC Code, Place of Supply etc.
- c. Invoices will be processed only upon completion of statutory requirement and further subject to following:
  - i. Vendor declaring such invoice in Form GST ANX-1
  - ii. Receipt of Goods or Services and Tax invoice by BHEL
- d. All invoices shall bear the HSN Code for each item separately (Harmonized System of Nomenclature)/ SAC code (Services Accounting Code).
- e. As the continuous uploading of tax invoices in GSTN portal (in GST ANX-1) is available for all (i.e. both Small & Large) tax payers under proposed new GST Return System, all invoice raised on BHEL may be uploaded immediately in GST portal on despatch of material /rendering of services. The supplier shall ensure availability of Invoice in GST portal before submission of invoice to BHEL. Invoices will be admitted by BHEL only if the invoices are available in GSTN portal (in BHEL's GST ANX-2).
- f. A declaration to the effect that all invoice particulars are/were uploaded in the GSTN network/ portal & all tax liability as per GST rules and regulations have been and will be discharged, shall be mentioned in the invoice. If not mentioned in the invoice, a separate declaration shall be submitted as per the requirement of BHEL.
- g. All documents like Test Certificate, LR copy, any other document mentioned in PO, shall be sent along with the vehicle/consignment. For all consignments received within the calendar month, input credit will be availed within that month in line with monthly returns filing cycle. In case of any discrepancy in the document or non-submission of documents mentioned in the PO, then BHEL will not be able to accept or account the material, in such case availing of tax credit will be deferred to next month or so.
- h. In case of discrepancy in the data uploaded by the supplier in the GSTN portal or in case of any shortages or rejection in the supply, then BHEL will not be able to avail the tax credit and will notify the supplier of the same. Supplier has to rectify the data discrepancy in the GSTN portal or issue credit note or debit note (details also to be uploaded in GSTN portal) for the shortages or rejections in the supplies or additional claims, within the calendar month informed by BHEL.



# BHARAT HEAVY ELECTRICALS LTD

## VALVES PURCHASE

Trichy - 620 014, India

### GENERAL TERMS AND CONDITIONS

Enquiry Reference: **ENSQN02348**

- i. In cases where invoice details have been uploaded by the vendor but failed to remit the GST amount to GST Department (Form PMT-08 or Form GST RET-01 to be submitted) within stipulated time, then GST paid on the invoices pertaining to the month for which GST return not filed by the vendor will be recovered from the vendor along with the applicable interest (currently 24% p.a) and all subsequent bills of the vendor will not be processed till filing of the GST return by the vendor.
- j. Under GST regime, BHEL has to discharge GST liability on LD recovered from suppliers/contractors. Hence applicable GST shall also be recoverable from suppliers/contractors on LD amount. For this, debit note will be issued by BHEL indicating the respective supply invoice number.
- k. In case any changes in taxes and duties as per Gov. Notification (including GST), the same shall be applicable from time to time.
- l. Duplicate copy of the Invoice meant for the transporter should accompany the material as stipulated under CE Rules 52A and 172C OR 57CE.
- m. TDS on GST shall be applicable as per the GST Act.
- n. In case GST credit is denied to BHEL due to non-receipt or delayed receipt of goods and/ or tax invoice or expiry of timeline prescribed in GST law for availing such ITC, or any other reasons not attributable to BHEL, GST amount claimed in the invoice shall be disallowed to the vendor.
- o. Where any GST liability arising on BHEL under Reverse Charge (RCM), the vendor has to submit the invoices to BHEL well within the timeline prescribed in GST Law, to enable BHEL to discharge the GST liability. If there is a delay in submission of invoice by the vendor resulting in delayed payment of GST by BHEL along with Interest, then such Interest payable or paid shall be recovered from the vendor.
- p. GST TDS will be deducted as per Section 51 of CGST Act 2017 and in line with Notification 50/2018 – Central Tax dated 13.09.2018. GST TDS certificate which will be generated in GST portal subsequent to vendor accepting the TDS deduction in the GST portal, will be issued to the vendor.

#### **4. SPECIAL PROVISIONS FOR MICRO AND SMALL ENTERPRISES (MSE):**

- a. 25% of the tendered quantity is earmarked for MSE suppliers in this tender.
- b. If L1 vendor (or) Counter offer accepted vendor/s is from a Micro / Small enterprise which put together covers 25% of the total tendered quantum, the 25% earmarking provision is not applicable.
- c. Out of the 25% tendered quantity reserved for MSE suppliers, 6.25% shall be earmarked for procurement from MSE owned by SC / ST entrepreneurs. In the event of failure of such Micro and Small enterprises to participate in the tender process or meet the tender requirements and the L1 price, the 6.25% sub-target for procurement ear-marked MSE owned by SC / ST entrepreneurs shall be met with other MSE enterprise/s.
- d. 3% reservation for women owned MSEs within the above mentioned 25% reservation. In the event of failure of such Micro and Small enterprises to participate in the tender process or meet the tender requirements and the L1 price, the 3% sub-target for procurement ear-marked MSE owned by women entrepreneurs shall be met with other MSE enterprise/s. The definition for MSEs owned by Women Entrepreneurs is clarified as:
  - i. In case of proprietary MSE, proprietor shall be woman.
  - ii. In case of partnership MSE, the women partners shall be holding at least 51% share in the unit.
  - iii. In case of private limited companies, at least 51% share shall be held by the women promoters.
- e. In case MSE vendor participating in the tender quotes within the price band of LI +15%, they will be allowed to supply the portion of the requirement subject to acceptance of LI price by MSE vendor. In case of more than one such MSE, the supply shall be shared proportionately, provided the available quantum can be split.
- f. In a tender where both MSE and Non-MSE Vendors have participated and non-MSE Vendor has become the lowest bidder and the quantum envisaged in the tender cannot be split, then the MSE vendor will be given preference for ordering the available quantum provided the MSE vendor quoted price is within L1 + 15%, and if the MSE vendor accepts the L1 rate.
- g. MSE suppliers can avail the intended benefits only if,

The vendor submits along with offer, a copy of the Udyam Registration Certificate.

(or)

The vendor has already submitted the above documents for the financial year of the date of part-1 bid opening and the MSE status has been updated in BHEL Trichy's records.

Non submission of such documents will lead to consideration of their bids at par with other bidders and MSE status of such suppliers shall be shifted to Non MSE supplier till the supplier submits these documents.



# BHARAT HEAVY ELECTRICALS LTD

## VALVES PURCHASE

Trichy - 620 014, India

### GENERAL TERMS AND CONDITIONS

Enquiry Reference: **ENSQN02348**

- h. Definitions of MSEs owned by SC/ST is under:
- In case of proprietorship firm, proprietor must be SC/ST.
  - In case of partnership firm, the SC/ST partners must be holding at least 51% shares in the unit.
  - In case of private limited companies, at least 51% share must be held by SC/ST promoters.
  - The caste/Tribe/Community certificate issued by the following authorities in the prescribed form for SCs/STs can be considered.
- i. Authorized to Issue SC/ST certificate:
- District Magistrate/Additional District Magistrate/Collector/Deputy commissioner/Additional Deputy Commissioner/Deputy collector/1st class stipendiary magistrate/Sub divisional Magistrate/Taluka Magistrate/Executive magistrate/Extra Assistant commissioner.
  - Chief Presidency magistrate/Additional chief presidency magistrate/Presidency magistrate.
  - Revenue Officer not below the rank of tehsildar.
  - Sub-Divisional officer of the area where the individual and / or his family normally resides.
- j. To avail the benefits of MSE under SC/ST category, the related documents as stated above should be submitted along with tender documents.
- k. Payment for MSE vendors will be as per MSMED Act, 2006.

## **5. RISK PURCHASE PENALTIES**

- a. In case of delay in delivery beyond PO delivery /mutually agreed delivery, or vendor fails /refuses to complete the PO as per terms, or insufficient facilities at vendor's works to execute a PO, BHEL has the right to get the items ordered elsewhere at the risk and cost of the vendor with notice to the vendor and the additional expenditure / difference in cost, if any, including consequential cost shall be recovered from the defaulted vendor. Also, in such case of withdrawal of orders, BHEL shall recover the additional expenditure / difference from vendor by adjusting against amount due to vendor and/or by invoking the BG and/or by any other suitable means as decided by BHEL. In addition, BHEL may recover from the defaulter vendor any loss to BHEL arising due to withdrawal of orders in such case, and action shall be taken as per latest revision of BHEL Guidelines for Suspension of Business dealings with Suppliers / Contractors.
- b. BHEL has the right to divert/cancel the order if the vendor has not procured minimum 50% of the quantity of raw materials within 60 days from PO date. Purchase order placed on steel mills and with proper payment voucher/proof will be considered for not cancelling the PO by BHEL. The submission of data by vendor for DB clearance by BHEL/QC shall be the proof of procurement. This is to avoid delay in project schedule due to delay in raw material procurement by vendors. In case the vendor fails to procure at least 50% of the quantity of raw materials within 60 days from PO date, BHEL has the right to get the items ordered elsewhere at the risk and cost of the defaulting Vendor and the additional expenditure / difference in cost, if any, including consequential cost shall be recovered from the defaulting Vendor and action shall be taken as per latest revision of BHEL Guidelines for Suspension of Business dealings with Suppliers / Contractors and SEARP.
- c. The defaulted vendor shall be liable for any loss, which BHEL may sustain by reason of such risk purchases in addition to liquidated damages as mentioned under LD clause.
- d. Vendors pending payments shall be withheld to cover the liabilities of BHEL towards risk purchase, if any.
- e. Reasons like power cut, labour issues, machine break down, etc. which are controllable by the sub-contractor shall not be accepted as reason for delay for delivery extension purposes.
- f. If PO delivery needs to be extended for reason attributable to BHEL, vendor may request BHEL in writing for delivery extension with justifications within 15 days from date of PO closure and before invoice.
- g. Process of calculating the risk and cost amount is as follows:  
Risk & Cost Amount=  $[(A-B) + (A \times H/100)]$   
Where,  
A= Value of Balance scope of Work/ Supply (\*) as per rates of new contract  
B= Value of Balance scope of Work/ Supply (\*) as per rates of old contract being paid to the contractor/ supplier at the time of termination of contract i.e. inclusive of PVC & ORC, if any.  
H = Overhead Factor to be taken as 5  
In case (A-B) is less than 0 (zero), value of (A-B) shall be taken as 0 (zero).  
\*(Balance scope of work/ supply)



# BHARAT HEAVY ELECTRICALS LTD

VALVES PURCHASE

Trichy - 620 014, India

GENERAL TERMS AND CONDITIONS

Enquiry Reference: **ENSQN02348**

Difference of Contract Quantities and Executed Quantities as on the date of issue of Letter for "Termination of Contract", shall be taken as balance scope of Work/ Supply for calculating risk & cost amount. Contract quantities are the quantities as per original contract. If, Contract has been amended, quantities as per amended Contract shall be considered as Contract Quantities. Items for which total quantities to be executed have exceeded the Contract Quantities based on drawings issued to contractor from time to time till issue of Termination letter, then for these items total Quantities as per issued drawings would be deemed to be contract quantities. Substitute/ extra items whose rates have already been approved would form part of contract quantities for this purpose. Substitute/ extra items which have been executed but rates have not been approved, would also form part of contract quantities for this purpose and rates of such items shall be determined in line with contractual provisions. In-case portion of work is being withdrawn, contract quantities pertaining to portion of work withdrawn shall be considered as 'Balance scope of work/supply' for calculating Risk & Cost amount.

- h. Vendors are cautioned that, withdrawal after price bid opening or after contract signing or PO/LOI acceptance will be construed as tampering with BHEL's tender process. Suitable action for suspension of further business with the vendor may be taken as per BHEL corporate procedures.
- i. Abridged version of extant 'Guidelines for suspension of business dealings with suppliers/ contractors' has now been uploaded on [www.bhel.com](http://www.bhel.com) on "supplier registration page" at the following link: [http://www.bhel.com/vender\\_registration/vender.php](http://www.bhel.com/vender_registration/vender.php) (Guidelines for suspension of business dealings with suppliers/ contractors).

## **6. GENERAL CONDITIONS**

- a. The manner of finalization will be as mentioned in the "Confirmation to the Terms and Conditions" attached. Separate orders will be released for each project and documents should be supplied for each order separately.
- b. BHEL reserves the right to reduce the tender quantity and to NOT to order for some or all material based on the changes in project.
- c. BHEL shall have the right to visit vendor works during the execution of contract along with end customer for verifying status, inspection and testing of the material.
- d. BHEL reserves the right to negotiate or re-float the tender in case the quoted prices are not acceptable.
- e. Supplier shall arrange packing to avoid lose or damages during Road Transport, Site handling & Storage.
- f. BHEL reserves the right to reject the offer of a particular bidder due to unsatisfactory past performance in the execution of a contract at any of BHEL projects / units.
- g. The Drawings and Technical documents given in this enquiry are the sole property of BHEL. This should not be misused in any form.
- h. Purchase Order, PO Item serial number, Material code, Quantity should be clearly marked on the packing
- i. Confirmation for compliance is to be given in the offer for all the conditions specified above and to the respective Purchase Specification.
- j. The bidder along with its associate/collaborators/sub-contractors/sub-vendors/consultants/service providers shall strictly adhere to BHEL fraud prevention policy (refer [www.bhel.com](http://www.bhel.com)) and shall immediately bring to the notice of the BHEL management about any fraud or suspected fraud as soon as it comes to their notice.
- k. For this procurement, Public Procurement (Preference to Make in India), Order 2017 dated 15.06.2017, 28.05.2018, 29.05.2019 and 04.06.2020, issued by DPIIT, Ministry of Commerce and Industry. If any subsequent Orders issued by the respective Nodal Ministry shall be applicable even if issued after issue of this NIT but before finalization of contract / PO / WO against this NIT. In the event of any Nodal Ministry prescribing higher or lower percentage of purchase and / or local content in respect of this procurement, same shall be applicable. Default purchase preference shall be 20% to local suppliers with default minimum local content of 50%.

## **7. DOCUMENTATION:**

- a. **With Consignment:** Duplicate for transporter copy, Original Invoice, Packing List, Delivery Challan, O&M manual (if applicable) Material Test Certificate, Test Certificates, Compliance Certificate, Guarantee/Warranty Certificate and other documents mentioned in PO/TDC/Drawing.
- b. **To Purchase:**



Maharatna Company

# BHARAT HEAVY ELECTRICALS LTD

## VALVES PURCHASE

Trichy - 620 014, India

### GENERAL TERMS AND CONDITIONS

Enquiry Reference: **ENSQN02348**

- i. FOR BHEL TRICHY case- Original Invoice, Duplicate for transporter copy, Packing list, LWB and Delivery challan, GST declaration as mentioned in point 3c.
- ii. FOR Site case- Original Invoice, Original LWB, Original Packing List, Original IBR documents, Original despatch clearance Certificate and Inspection report, Test certificates as per PO, Original Site Acknowledgment etc.
- c. **Identification:** Material code, Purchase Order, PO item serial number, Unique serial number if any should be provided in all despatch documents, materials and packing clearly.

#### 8. **TENDER EVALUATION:**

##### a. **Techno-commercial Bid.**

- i. All vendors should submit General arrangement drawing, datasheet and C&I diagram (if any) of the offered product
- ii. Point by point technical confirmation of all pages of our technical specifications and commercial conditions are required with your sign and seal along with techno commercial offer.
- iii. Offers from supplier not having technical capability or not agreed for commercial terms, will be rejected.

##### b. **Price Bid.**

- i. Bidders qualified for part I will be intimated for participating in priced bid opening.
- ii. L1 bidder will be decided based on landed cost for the equipment to BHEL.

##### **Indigenous Vendors**

Total Landed cost/rate for each item = FOR Rate in INR (A) + Applicable Taxes (B) + Loading non-acceptance of commercial terms (C) – Applicable input tax credit (D)

A - Indigenous vendors submit offers on Free on Road (FOR), Stores, HPBP BHEL Trichy in INR.

B - Applicable GST and any other charges quoted by indigenous vendors will be added to the base price.

C - Loading for non-acceptance of payment terms, delivery schedule & liquidated damages (LD) will be added to the F.O.R. value for arriving the landed rate.

D - However, input tax credit shall be availed for GST, hence the same is excluded for arriving at the landed cost.

- iii. In case of tie for the L1 positions,
  - a. In the course of evaluation, if more than one bidder happens to occupy L1 status, effective L1 will be decided by soliciting discounts from respective L1 bidders.
  - b. In case more than one bidder happens to occupy the L1 status even after soliciting discounts, the L1 bidder shall be decided by a toss/draw of lots, in the presence of the respective L1 bidders(s) or their representative(s).
  - c. Ranking will be done accordingly, BHEL's decision in such situation shall be final and binding.

#### Note:

All clarifications / issues shall be addressed directly to the tender issuing (procurement) department's officials whose contact details are provided below

(1)  
S Suresh  
Deputy Manager  
Valves Purchase  
24 Building, 3<sup>rd</sup> Floor,  
BHEL, Trichy-620014  
+91 431 2578668  
[suresh.s@bhel.in](mailto:suresh.s@bhel.in)

(2)  
Ajay Kumar Gupta  
AGM  
Valves Purchase  
24 Building, 3<sup>rd</sup> Floor,  
BHEL, Trichy-620014  
+91 431 2578156  
[ajaykumar.gupta@bhel.in](mailto:ajaykumar.gupta@bhel.in)

\*\*\*\*\*

