

Tender Enquiry No	2122-087E
Enquiry date	16.03.2022
Last time and date of tender submission	14:00 Dt.31.03.2022
Tender opening time and date	16:30 Dt. 31.03.2022
Quotation Parts	Two-part
Item Description	Forged Eyebolts
Delivery schedule (In days)	Within 90 days from PO date
Validity of offer (In days)	70 days from date of tender opening
Counter Offer	No counter offer is applicable except MSE purchase preference
Quantity Variation	+/-10% may be acceptable with prior consent of BHEL in writing
Documents required along with supply of material	
Test Certificate and other Quality related documents	Required as per QP/BPS/IS /TDCs/Drawings mentioned in list of items

M/s Ispat Silpa is not allowed to participate in this tender.

Reverse auction will not be conducted in this tender. The Items are not reserved for MSEs (micro and small) i.e. non MSE bidders can also participate. There is no counter offer in this tender enquiry excepts MSE purchase preference (Ref. Clause 22 of GCC). Rates quoted should be F.O.R. BHEL Goindwal basis only.

This is a two-part tender i.e. Part-1 and Part2. Part-1 is techno-commercial bid evaluation and Part-2 is price bid comparison. The Part-1 qualified bidders will only be eligible for part-2 opening.

Please take special care regarding technical requirement e.g. material grade and material class (specially in material class-2 of SS eyebolts) before quoting.

Quotation Submission

This tender is through e-procurement mode for supply of “Forged Eyebolts” as per specifications mentioned in tender terms. Interested bidders / suppliers shall submit their offer through e-procurement mode at <https://eprocurebhel.co.in/>. Offers in any other mode will not be accepted. In case of any difficulty faced while registering on BHEL’s e-Procurement portal developed by NIC, queries may be addressed to 0120-4001002, 0120-4001005 and 0120-6277787; email: support-eproc@nic.in. These details are also available on ‘Contact Us’ page of the portal.

Pre-Qualification terms for participating in the tender

- Supplier should be manufacturer of Forged Fasteners. Supplier to upload undertaking/ISO certificate/documentary evidence for being manufacturer.
- Supplier shall submit customer Purchase Orders (one or more of any party) and their invoices for supply of fasteners with minimum cumulative value of Rs. 5,00,000 (Rs. Five lakhs Only) as proof. Purchase Order/s and their invoices date should be 01.03.2019 or afterwards and upto 01.03.2022.

Start-ups shall be exempted from this criteria of Purchase order and invoice submission without any relaxation in quality standards or technical parameters as per D.O. No. 5(4)/2016-BE-I dated 15.02.2017. For claiming Start-Up exemption, vendors have to submit DPIIT (Dept. of Promotion

of Industry and Internal Trade)/DIPP (Department for Industrial Policy and Promotion) recognition certificates.

BHEL may carry out evaluation of bidder's capability. BHEL reserves the right to accept / reject any offer based on evaluation of bidder's capability. For verification of data presented for pre-qualification bid, BHEL may decide to visit the bidder(s) works. Any fact found deviating from bids during evaluation shall make the bidder liable to be dis-qualified.

Special Tender Terms

1. SCOPE OF SUPPLY:

Material shall be supplied as per the applicable latest Material Standard requirements/BPS/Drawing and other requirement as given in the Purchase Order/list of items. National & International material standards shall have to be arranged by vendors themselves. The bidders have to arrange latest applicable IS standards by their own. **Comparison of rates quoted by bidders shall be done as per set only (check column A of table of list of items). The quotations where bidders have quoted for both Eyebolts and nuts (i.e. both items of set) shall only be considered. Wherever the nuts are repeating, minimum of the quoted rates will be considered for such nuts. So please quote single rate wherever nuts are repeating. The material shall supply in assembled condition only i.e. assembly of Eyebolt and nut.**

Inspection can be done by BHEL or can arrange third party for inspection. In case of TPI/BHEL inspection, the Material shall be inspected as per attached Standard Quality Assurance Plan mentioned against each item. The material shall be dispatched by vendor only after dispatch clearance from BHEL IVP. TPI inspection charges will be borne by BHEL. The vendor has to arrange their own gauges for inspection. Please note that the TPI inspection may take 5 to 6 days considering visual inspection and testing witness (Check applicable Quality plan.

2. LIST OF ITEMS:

Following items are there in this tender enquiry: -

Sl. No.	MATL_NO	DESCRIPTION	Qty in No.	Unit	Unit of L1 evaluation / comparison (A)	Drawing	Quality assurance plan for inspection
1	964658950000	EYE BOLT M24X195X60-B8M	2	no	Set	3V000135002/01	BHE:SQAP:SS:01, Dt:12.08.2021
2	964658960000	NUT -M24x3 - 8M	2	no		4V000727368/00	BHE:SQAP:SS:01, Dt:12.08.2021
3	964657730000	EYE BOLT-1/2"x50 -B8M	600	no	Set	3V000125684/00	BHE:SQAP:SS:01, Dt:12.08.2021
4	964656480000	HEX NUT-1/2"-13UNC-2B-GR.8M	600	no		3V000123249/00	BHE:SQAP:SS:01, Dt:12.08.2021
5	964657740000	EYE BOLT-1/2"x60 -B8M	600	no	Set	3V000225684/00	BHE:SQAP:SS:01, Dt:12.08.2021
6	964656480000	HEX NUT-1/2"-13UNC-2B-GR.8M	600	no		3V000123249/00	BHE:SQAP:SS:01, Dt:12.08.2021
7	964657750000	EYE BOLT-1/2"x75 -B8M-0003	1200	no	Set	3V000325684/00	BHE:SQAP:SS:01, Dt:12.08.2021
8	964656480000	HEX NUT-1/2"-13UNC-2B-GR.8M	1200	no		3V000123249/00	BHE:SQAP:SS:01, Dt:12.08.2021
9	964657780000	EYE BOLT-5/8"x100 -B8M-0007	1000	no	Set	3V000725684/00	BHE:SQAP:SS:01, Dt:12.08.2021
10	964656490000	HEX NUT-5/8"-11UNC-2B-GR.8M	1000	no		3V000223249/00	BHE:SQAP:SS:01, Dt:12.08.2021
11	964657800000	EYE BOLT-5/8"x130 -B8M-0009	300	no	Set	3V000925684/00	BHE:SQAP:SS:01, Dt:12.08.2021
12	964656490000	HEX NUT-5/8"-11UNC-2B-GR.8M	300	no		3V000223249/00	BHE:SQAP:SS:01, Dt:12.08.2021
13	964657710000	EYE BOLT-5/8"x90 -B8M	600	no	Set	3V000625684/00	BHE:SQAP:SS:01, Dt:12.08.2021
14	964656490000	HEX NUT-5/8"-11UNC-2B-GR.8M	600	no		3V000223249/00	BHE:SQAP:SS:01, Dt:12.08.2021
15	964566790000	EYE BOLT-1/2"x75 -B7-F503	1000	no	Set	3VF50306880/01	BHE:QAP:FAS:02 Dt.15.03.2019
16	964562790000	NUT -1/2" -2H-N073	1000	no		3VN07306876/03	BHE:QAP:FAS:02 Dt.15.03.2019

17	964563960000	EYE BOLT-M12x70 -B7-2476	1500	no	Set	4V247604073/02	BHE:QAP:FAS:02 Dt.15.03.2019
18	413200001200	NUT -M12 -CL8-IS1364P3	1500	no		BPS 41320	BHE:QAP:FAS:02 Dt.15.03.2019

Note- The L1 evaluation will be done as per Set/no only as mentioned in column A of above table, so please take special attention while quoting prices in Part-II (BOQ).

3. PACKAGING & SUPPLY

All material has to be dispatched in packing boxes only i.e. wooden or carton or cardboards with material code, description, grade and quantity. Preferable is to supply no of packing boxes with small quantities e.g. if 500 Eyebolts are to supplied then it may be supplied in 10 boxes containing 50Pcs. Box must have TAG containing Purchase Order No., Material Code, Material Description (as mentioned in PO) along with Unit weight of each item and Total weight of Box and Total Quantity in Box. No cost for these boxes will be given separately and must be included in prices only.

It should be noted that Supply of material should be done in sets and in assembled condition (i.e. Assembly of eyebolt and nut) only otherwise BHEL can reject the material.

4. VALIDITY OF OFFERS AND CONTRACT:

The offers shall be kept open for acceptance for **70 days** from the date of opening of the tender. In case of extension of tender opening date, the validity shall be suitably revised.

5. DELIVERY SCHEDULE:

The material shall be supplied within 90 days from the date of purchase order. If supplier fails to supply items within PO delivery date, BHEL reserves the right to cancel the PO and initiate risk purchase against failed supplier as per BHEL risk purchase guidelines.

6. PREFERENCE TO MAKE IN INDIA

This procurement shall be governed by notification no. P-45021/2/2017-PP (BE-II) dated 16.09.2020 of Government of India issued by DPIIT and subsequent circulars issued afterwards. Accordingly, the minimum local content required for these Eyebolts is 50% for class-1 local supplier and only class-1 suppliers are eligible to quote.

7. PREVENTIVE CHECKS TO ELIMINATE SUSPECTED CARTEL FORMATION

The Bidder declares that they will not enter into any illegal or undisclosed agreement or understanding, whether formal or informal with other Bidder(s). This applies in particular to prices, specifications, certifications, subsidiary contracts, submission or non-submission of bids or any other actions to restrict competitiveness or to introduce cartelization in the bidding process. In case, the Bidder is found having indulged in above activities, suitable action shall be taken by BHEL as per extant policies/ guidelines.

8. PART-I: TECHNO-COMMERCIAL BID should contain *all the documents/confirmations as per following details:*

- a) Duly filled and signed part-1 format.
- b) Documents as per pre-qualification terms.
- c) Duly filled Annexure-A (Declaration for RESTRICTIONS UNDER RULE 144(XI)).
- d) Duly filled Annexure-B (Non-Disclosure Agreement).

9. RISK PURCHASE CLAUSE:

BHEL at its option will be entitled to terminate the contract and to purchase elsewhere at the risk and cost of the supplier either the whole of the goods or any part which the supplier has failed to deliver or dispatch within the time stipulated as per contract delivery terms. The supplier shall be liable for losses, which BHEL may sustain by way of such risk purchases.

The value shall be calculated as follows:

$$\text{Risk \& Cost Amount} = [(A-B) + (A \times H/100)]$$

Where,

A= Value of Balance scope of Supply (*) as per rates of new contract

B= Value of Balance scope of Supply (*) as per rates of old contract being paid to the supplier at the time of termination of contract i.e. inclusive of PVC, if any.

H = Overhead Factor shall be taken as 5

In case (A-B) is less than 0 (zero), value of (A-B) shall be taken as 0 (zero).

* Balance Scope of Supply: Difference of Contract Quantities and Executed Quantities as on the date of issue of Letter for 'Termination of Contract', shall be taken as balance scope of Supply for calculating risk & cost amount.

Contract quantities are the quantities as per original contract. If, Contract has been amended, quantities as per amended Contract shall be considered as Contract Quantities.

These Special terms & conditions and GCC collectively are the part of tender terms and conditions All Special terms will overrule GCC.



General Contract Conditions (GCC) of MM Tenders

BHARAT HEAVY ELECTRICALS LIMITED

Industrial Valve Plant: 433, Industrial Complex,
Goindwal Sahib, Dist. Tarn Taran,
Punjab-143422 (INDIA)

TABLE OF CONTENTS

1. INSTRUCTION TO BIDDER.....	2
2. SCOPE OF SUPPLY	2
3. PRICE BASIS.....	3
4. DISCREPANCY IN WORDS AND FIGURES.....	3
5. EVALUATION IN CASE OF MORE THAN ONE L-1 BIDDER	3
6. REVERSE AUCTION.....	4
7. VALIDITY OF OFFERS.....	4
8. SUPPLIED MATERIAL ADJUSTMENT	4
9. DELIVERY SCHEDULE.....	4
10. LIQUIDATED DAMAGES (LD) FOR LATE DELIVERY	4
11. PAYMENT TERMS.....	5
12. TAXES & DUTIES	5
13. LIABILITY UNDER REVERSE CHARGE (RCM)	6
14. ACCESS TO MANUFACTURING PREMISES.....	6
15. INSPECTION	6
16. GUARANTEE / WARRANTEE AND CORRESPONDING REPAIR / REPLACEMENT OF GOODS	7
17. LOI (LETTER OF INTENT).....	7
18. SUB-CONTRACT	7
19. RISK PURCHASE	7
20. FORCE MAJEURE	8
21. CLARIFICATIONS.....	8
22. PREFERENCES FOR MICRO AND SMALL ENTERPRISES (MSEs)	9
23. PREFERENCE TO MAKE IN INDIA.....	9
24. RESTRICTIONS UNDER RULE 144(XI) OF THE GENERAL FINANCIAL RULES (GFRs), 2017	9
25. DISPUTES.....	10
26. JURISDICTION	10
27. BANNED FIRMS.....	10
28. FRAUD PREVENTION POLICY	10
29. PREVENTIVE CHECKS TO ELIMINATE SUSPECTED CARTEL FORMATION. .	11
30. SUSPENSION OF BUSINESS DEALINGS WITH DEFAULTERS	11
31. GENERAL.....	12





General Contract Conditions (GCC) of MM Tenders

BHARAT HEAVY ELECTRICALS LIMITED

Industrial Valve Plant: 433, Industrial Complex,
Goindwal Sahib, Dist. Tarn Taran,
Punjab-143422 (INDIA)

1. INSTRUCTION TO BIDDER

Quotations shall be submitted before due date and time. Late offers are liable to be rejected, so please ensure to submit bid well within due date and time. Techno-commercial part will be opened on due date.

Based on evaluation of techno-commercial offers, Price bids of bidders who qualify from techno-commercial evaluation shall be opened. BHEL may decide to open the Price bid same day at 1700 hrs. If not opened on the same day, all qualifying bidders shall be notified for date of opening of Price bids by email/fax/post/courier/E-procurement system generated email.

1.1 Instruction to Bidder (In case of Non-E-Procurement / Paper/ Manual/ Hard Copy based tenders)

Sealed Tenders can be dropped in the tender box labeled as 'Tender box for MM contracts'. This tender box is located at the entrance of Admin block BHEL Goindwal. Fax (01859-222061) / E-Mail (tendermm_ivp@bhel.in) offers received in time shall be considered only when such offers are complete in all respects. In case of bulky tenders, please handover quotation to Sh. Rakesh Kumar/ SDGM - Head-MM or Sh. Sumeet Bansal / Sr. Manager - MM [Contact: 01859 224 615 / 628]. Bid can be send to following address:

**BHEL, Industrial Valve Plant,
#433, Industrial Complex,
Goindwal Sahib, Distt. Tarn Taran,
Punjab-143422.**

1.2 Instruction to bidder (In case of E-Procurement)

1. Interested bidders / suppliers shall submit their offer through e-procurement mode at <https://eprocurebhel.co.in/>.
2. Offers in any other mode will not be accepted.
3. Procedure for Submission of Tender is available in the "Bidder Manual Kit" at E-tender portal <https://eprocurebhel.co.in/> only.
4. In case of any difficulty faced while registering on BHEL's e-Procurement portal developed by NIC, queries may be addressed to 0120-4001002, 0120-4001005 and 0120-6277787; email: support-eproc@nic.in. These details are also available on 'Contact Us' page of the portal.
5. Before uploading scanned documents if any, the bidders shall sign on all the statements, documents, certificates uploaded by him, owning responsibility for their correctness / authenticity.
6. **Disclaimer clause:** Neither the Organization (Bharat Heavy Electricals Ltd.) nor the service provider is responsible for any failure of submission of bids due to failure of internet or other connectivity problems or reasons thereof.

2. SCOPE OF SUPPLY

Material shall be supplied as per the applicable latest Technical Delivery Conditions (TDC)/ Material Standard requirements/BPS/Drawing and other requirement as given in the Tender Enquiry. National & International material Standards shall have to be arranged by vendors themselves. Latest applicable revisions of standards/procedures to be referred.





General Contract Conditions (GCC) of MM Tenders

BHARAT HEAVY ELECTRICALS LIMITED

Industrial Valve Plant: 433, Industrial Complex,
Goindwal Sahib, Dist. Tarn Taran,
Punjab-143422 (INDIA)

All required tests as called in referred material standard/BHEL/TDC/drawing etc. shall be carried out by vendor at no extra cost. Material Test Certificates (MTC), inspection reports and Compliance/Guarantee Certificate are to be provided along with the supplies.

3. PRICE BASIS

1. Order of enquiry item sl. no. shall be maintained in the quotation.
2. The rates quoted shall be firm and fixed. No price variation is proposed and allowed.
3. Rates quoted should be FOR BHEL Goindwal basis. The offers quoted on other than FOR Goindwal basis are liable to be rejected.

In case bidder has quoted Ex-works prices, then he/she will be given an opportunity to accept price basis as FOR Goindwal either by accepting delivery as FOR Goindwal in same quoted price or by providing loading factor on his/her quoted ex-works prices to make them FOR prices.

Variation in GST or any other statutory levies during contractual delivery period shall be to BHEL's account.

4. DISCREPANCY IN WORDS AND FIGURES

1. If, in the price structure quoted for the required goods/ services/ works, there is discrepancy between the unit price and the total price (which is obtained by multiplying the unit price by the quantity), the unit price shall prevail and the total price corrected accordingly, unless in the opinion of the purchaser there is an obvious misplacement of the decimal point in the unit price, in which case the total price as quoted shall govern and the unit price corrected accordingly.
2. If there is an error in a total corresponding to the addition or subtraction of subtotals, the subtotals shall prevail and the total shall be corrected; and
3. If there is a discrepancy between words and figures, the amount in words shall prevail, unless the amount expressed in words is related to an arithmetic error, in which case the amount in figures shall prevail subject of (a) and (b) above.
4. If there is such discrepancy in an offer, the same shall be conveyed to the bidder with target date upto which the bidder has to send his acceptance on the above lines and if the bidder does not agree to the decision of the purchaser, the bid is liable to be ignored.
5. Bids should be free from correction, overwriting, using corrective fluid, etc. Any interlineation, cutting, erasure or overwriting shall be valid only if they are attested under full signature(s) of person(s) signing the bid else shall be liable for rejection.
6. All overwriting/cutting, etc will be numbered by bid opening officials and announced during bid opening.

5. EVALUATION IN CASE OF MORE THAN ONE L-1 BIDDER

In the course of evaluation, if more than one bidder happens to occupy L1 status, effective L1 will be decided by soliciting discounts from the respective L1 bidders.





General Contract Conditions (GCC) of MM Tenders

BHARAT HEAVY ELECTRICALS LIMITED

Industrial Valve Plant: 433, Industrial Complex,
Goindwal Sahib, Dist. Tarn Taran,
Punjab-143422 (INDIA)

In case more than one bidder happens to occupy the L1 status even after soliciting discounts, the L1 bidder shall be decided by a toss / draw of lots, in the presence of the respective L1 bidder(s) or their representative(s).

Ranking will be done accordingly. BHEL's decision in such situations shall be final and binding.

6. REVERSE AUCTION

In case, it is declared in special terms & conditions of tender enquiry that RA is applicable for the NIT, then RA will be conducted as per following clause:

BHEL shall be resorting to Reverse Auction (RA) (Guidelines as available on <https://www.bhel.com/>) for this tender. RA shall be conducted among the techno-commercially qualified bidders as per RA guidelines.

Price bids of all techno-commercially qualified bidders shall be opened and same shall be considered for RA. In case any bidder(s) do(es) not participate in online Reverse Auction, their sealed envelope price bid along with applicable loading, if any, shall be considered for ranking.

7. VALIDITY OF OFFERS

The offers shall be kept open for acceptance 'for number of days mentioned in special terms and conditions' from the date of opening of the tender. In case of tender extension, the bid validity shall be considered from the date of tender opening.

8. SUPPLIED MATERIAL ADJUSTMENT

Item/s pending in previous PO has to be billed in previous PO only. Otherwise, BHEL will be free to adjust the supplies in previous PO. Any implication of tax will be on supplier's account. For this it is desirable that vendor should reconcile the pending PO statement every month/frequently with BHEL. Vendor can also view these details at Portal (<https://trichy.bhel.com/mm/index.jsp>).

9. DELIVERY SCHEDULE

Supplies shall be affected and completed as per schedule mentioned in special terms and conditions. **Further, BHEL may release delivery schedule from time to time based upon our requirement with mutual understanding.** Vendor shall be required to complete the order as per the BHEL schedule requested. Commencement of delivery period shall be reckoned from the date of PO / LOI or any other agreed milestone.

10. LIQUIDATED DAMAGES (LD) FOR LATE DELIVERY

Time is the essence of the contract'. As such, delivery of goods specified in the Purchase Orders released under the scope of this contract shall be made within the time limit prescribed therein. Penalty for late delivery will be applicable @0.5% of the undelivered portion per week of the delay or part thereof subject to a maximum of 10% of the undelivered portion.





General Contract Conditions (GCC) of MM Tenders

BHARAT HEAVY ELECTRICALS LIMITED

Industrial Valve Plant: 433, Industrial Complex,
Goindwal Sahib, Dist. Tarn Taran,
Punjab-143422 (INDIA)

In case of Ex-works delivery terms for indigenous supplies, the document date (Invoice/Challan date) in Goods Receipt (GR) document shall be reckoned for LD deduction. In case of FOR Delivery terms for Indigenous supplies, the posting date in GR document shall be reckoned for LD deduction.

If any vendor does not accept LD $\frac{1}{2}\%$ of the supply for each week of delay subject to a maximum of 5%, their offer is likely to be rejected by BHEL and the price bid shall not be opened. Bidders accepting for 10% LD shall not be loaded on account of LD. However, bidders who offer any other % LD [between 5% to 10%] shall be loaded @ % deviation from 10% and their accepted %. e.g. If a bidder accepts for a max of 7% LD only, their offer would be loaded @ 3% (10 – 7 = 3).

BHEL reserves the right to receive or not receive the material after the due date of PO. Applicable GST shall also be recovered from suppliers/contractors on LD amount. For this Debit note will be issued by BHEL indicating the respective supply invoice number.

11. PAYMENT TERMS

1. Due payment against supplies received shall be due after 30 days of receipt and acceptance of material and shall be paid within next 15 days' period. In case of any deviation from standard payment term mentioned, BHEL at its discretion may load on the item price at "Base rate of SBI (as applicable on the date of bid opening; Techno-commercial bid opening) + 6% shall be considered for loading for the period of relaxation sought by bidders.
2. Documents to be submitted (if applicable)
 - i) Tax invoice (Invoice shall be GST compliant and should contains all the required information such as GST No, HSN code etc.)
 - ii) Transporter copy along with material/consignment.
 - iii) Material Test Certificates (MTC) and
 - iv) Compliance Certificate.
3. GST registration number is to be submitted by qualified vendor as per GST law.
4. It is mandatory to mention proper material codes in the invoices and separate invoices to be raised for different POs.
5. **BHEL releases payment through EFT mode ONLY. Necessary details may please be submitted by filling required format before release of payment.**

12. TAXES & DUTIES

Payment of GST portion will be released to vendor only upon completion of statutory requirement and further subject to following:

- a) Vendor declaring such invoice in his GSTR-1 and
- b) Receipt of goods and Tax invoice by BHEL and
- c) Confirmation of payment of GST thereon by vendor on GSTN portal.
- d) Above is subject to receipt of goods/service and tax invoice thereof along with vendor declaring invoice in his return and paying GST within timeline prescribed for availing ITC by BHEL.

Following may please be noted for availing Input Tax Credit (ITC) by BHEL:





General Contract Conditions (GCC) of MM Tenders

BHARAT HEAVY ELECTRICALS LIMITED

Industrial Valve Plant: 433, Industrial Complex,
Goindwal Sahib, Dist. Tarn Taran,
Punjab-143422 (INDIA)

1. Since ITC can be availed only when BHEL is in possession of GST Tax invoice and after receipt of goods. Thus, vendor to ensure timely dispatch of goods and Tax invoice. It may be noted that in case of any delay in receipt of Tax Invoice and/or receipt of goods, the ITC availment by BHEL will get delayed thus entailing additional cash outflow & may even get denied if ITC availment timelines are breached.
2. Further ITC can be availed only when vendor has declared such invoice in his outward supply Return GSTR-1 and after GST thereon has been paid by him at the time of filing of monthly Return.
3. If GST credit is delayed/denied to BHEL due to non/delayed receipt of goods and/or tax invoice or expiry of timeline prescribed in GST law for availing such ITC, or any other reasons not attributable to BHEL, GST amount shall be recoverable from vendor along with interest levied/leviable on BHEL.
4. Further, in case vendor delays declaring such invoice in his return and GST credit availed by BHEL is denied or reversed subsequently as per GST law, GST amount paid by BHEL towards such ITC reversal as per GST law shall be recoverable from vendor/contractor along with interest levied/leviable on BHEL.

13. LIABILITY UNDER REVERSE CHARGE (RCM)

Any GST liability arising on BHEL under Reverse Charge (RCM) before actual receipt of goods and/ or Invoice thereof would be subject to recovery of Interest leviable for the period between the date of such liability and actual date of eligibility of ITC based on receipt of goods, receipt of Invoices and other conditions specified in GST Law as applicable.

14. ACCESS TO MANUFACTURING PREMISES

While Purchase Orders placed on the vendor are under execution, authorized representatives of BHEL shall be allowed free access to the manufacturing facilities for the purpose of inspection or monitoring the progress of purchase orders. This access will also be extended to representatives of BHEL's customers accompanying the authorized representative/s of BHEL (which shall be intimated in advance), if our contractual requirements with our customers call for the same.

15. INSPECTION

1. The seller shall give adequate notice, of 1 week or as mutually agreed period, in writing to the Purchaser about the date and place at which the goods will be ready for inspection/ testing, as provided for in the contract.
2. Purchaser or his authorized representative shall be entitled to carry out inspection of material and workmanship/Surveillance Audit at Seller's premises or at his sub-contractor's premises at all reasonable times during execution of contract; Such inspection, examination and testing, if made, shall not absolve the Seller from his obligations under the contract. No additional charges shall be claimed for such inspections. Moreover, all required infrastructure (testing, tools etc) have to be arranged by supplier.
3. Any inspection carried out before supply by vendor/incoming stage at BHEL notwithstanding, if any defect/non-conformity is noted during processing, the same shall be attended/replaced by vendor at no extra cost.
4. BHEL representative from unit or CQ is authorized to carry out audits along with TPIA at vendor's works before clearing the items for dispatch.





General Contract Conditions (GCC) of MM Tenders

BHARAT HEAVY ELECTRICALS LIMITED

Industrial Valve Plant: 433, Industrial Complex,
Goindwal Sahib, Dist. Tarn Taran,
Punjab-143422 (INDIA)

5. Necessary tooling including thread gauges etc. have to be arranged by vendor. Only in exceptional cases, based on BHEL discretions item/nature, BHEL may consider request to provide gauges if available with BHEL. But in no case this shall be linked with delivery of material.

16. GUARANTEE / WARRANTEE AND CORRESPONDING REPAIR / REPLACEMENT OF GOODS

Goods shall comply with the specifications for material, workmanship and performance. Vendor shall give a guarantee / warrantee of 18 months from the date of dispatch or 12 months from date of receipt, against manufacturing defects, whichever is earlier. In case of non-acceptance of this term, bid will be rejected.

If the material is rejected due to defective workmanship during inspection or at the time of actual use, within the guarantee / warrantee period, the rejected material shall be replaced by the supplier. Corresponding quantity shall be treated as unsupplied against respective purchase order till replacement is received at BHEL. If the material is found defective and rejected during use for which payment has already been released the rejected quantity shall be supplied free of cost by the vendor within a month of intimation of the rejection by BHEL.

Lifting of rejected material is under Supplier's scope. BHEL will inform related invoice, quantity etc. to supplier. Supplier is expected to give the plan to lift and advance intimation when visiting to lift the material. Material should be lifted within one month from date of intimation. After one-month BHEL will not be responsible for rejected material. BHEL may decide to send the rejected material on to Pay basis to supplier. Any leniency/ unresponsiveness/delay on part of supplier may lead to appropriate action by BHEL. Any request to postpone in written may be considered but replacement should not be linked with lifting of material.

17. LOI (LETTER OF INTENT)

BHEL may issue LOI prior to the PO for any reason whatsoever. The LOI in such cases is to be treated as PO for all practical purposes and all the Terms & Conditions of the tender shall be applicable from the date of issue of LOI.

18. SUB-CONTRACT

The purchase order or any part thereof shall not be sub-contracted, assigned or otherwise transferred without previously obtaining the BHEL's consent in writing.

19. RISK PURCHASE

BHEL at its option will be entitled for withdrawal of portion of balance supply or termination of the contract and to purchase elsewhere at the risk and cost of the supplier either the whole of the goods or any part which the supplier has failed to deliver or dispatch within the time stipulated as per contract delivery terms. The supplier shall be liable for losses, which BHEL may sustain by way of such risk purchases.





General Contract Conditions (GCC) of MM Tenders

BHARAT HEAVY ELECTRICALS LIMITED

Industrial Valve Plant: 433, Industrial Complex,
Goindwal Sahib, Dist. Tarn Taran,
Punjab-143422 (INDIA)

The value shall be calculated as follows:

$$\text{Risk \& Cost Amount} = [(A-B) + (A \times H/100)]$$

Where,

A= Value of Balance scope of Supply (*) as per rates of new contract

B= Value of Balance scope of Supply (*) as per rates of old contract being paid to the supplier at the time of termination of contract i.e. inclusive of PVC, if any.

H = Overhead Factor shall be taken as 5

In case (A-B) is less than 0 (zero), value of (A-B) shall be taken as 0 (zero).

* **Balance Scope of Supply:** Difference of Contract Quantities and Executed Quantities as on the date of issue of Letter for 'Termination of Contract', shall be taken as balance scope of Supply for calculating risk & cost amount.

Contract quantities are the quantities as per original contract. If, Contract has been amended, quantities as per amended Contract shall be considered as Contract Quantities.

20. FORCE MAJEURE

If at any time during the continuance of the contract, the performance in which or in any part by either party of any obligations under the contract are prevented or delayed by reason of any war, hostilities, acts of public enemy, civil commotion, sabotage, fires, explosions, epidemics, quarantine restrictions, or acts of God (hereinafter referred to "an events" then provided the notice of happening of any such event is given by either party to the other within 21 days of the occurrence thereof, neither party shall by reason of such event be entitled to terminate the contract nor shall either party have any claim for damages against the other in respect of such non-performance and delay in performance and delivery under the contract shall be resumed as soon as practicable after such event has come to an end or ceased to exist. If the performance in whole or part of any obligation under the contract is prevented or delayed by reason of any such event, claims of extension of time shall be granted for periods considered reasonable by BHEL subject to prior notification by the vendor to BHEL of the particulars of the event and supply to BHEL, if required, of any supporting evidence. Any waiver of time in respect of partial installment shall not be deemed a waiver of time in respect of remaining deliveries.

21. CLARIFICATIONS

The correspondence exchanged against the tender from both tenderer and BHEL through email/e-procurement are considered as valid document legally though it is not signed. It is treated as valid confirmations made on behalf of the respective company and very much comes under the legal ambit of the business transaction and hence it is binding on both the parties to the business. Any transaction pertaining to the tender from both the parties of business done round the clock irrespective of the office or business hours of the companies, are valid legally and binding on both the parties. This applies to the extent only in such cases where deadline time for transaction is not specifically declared by either or both the parties to the business.





General Contract Conditions (GCC) of MM Tenders

BHARAT HEAVY ELECTRICALS LIMITED

Industrial Valve Plant: 433, Industrial Complex,
Goindwal Sahib, Dist. Tarn Taran,
Punjab-143422 (INDIA)

22. PREFERENCES FOR MICRO AND SMALL ENTERPRISES (MSEs)

Preferences as mentioned in “Public Procurement Policy for Micro and Small Enterprises (MSEs) Order, 2012” & “Public Procurement Policy for Micro and Small Enterprises (MSEs) Amendment Order, 2018”, or as per latest guidelines issued by government shall be given to Micro and Small enterprises.

Main points which are mentioned in the above orders are as follows:

- 25% Procurement of the tender value shall be made from MSE (Micro, Small Enterprises) firms.
- 25% of the 25% quantity (i.e. 6.25% of the tender quantity) offered to the MSE's shall be reserved for MSE's owned by SC/STs. Failure to participate by any MSE owned by SC/ST's; this 6.25% quantity shall be procured from other MSEs.
- 3% from within the 25% quantity offered to the MSE's shall be reserved for women owned MSE's. Failure to participate by any MSE owned by women; this 3% quantity shall be procured from other MSEs.
- EMD shall be exempted for MSE's. All these benefits are subject to production of all statutory documents
- In tender, participating Micro and Small Enterprises quoting price within price band of L1+15 per cent shall also be allowed to supply a portion of requirement by bringing down their price to L1 price in a situation where L1 price is from someone other than a Micro and Small Enterprise and such Micro and Small Enterprise shall be allowed to supply up to 25 per cent of total tendered value. In case of more than one such Micro and Small Enterprise, the supply shall be shared proportionately (to tendered quantity).

MSE suppliers can avail the intended benefits only if they submit **Udyam Registration Certificate** along with the offer. No other document shall be considered for availing MSE benefits. Non-submission of such document will lead to consideration of their bid at par with other bidders. No benefit shall be applicable for this enquiry if any deficiency in the above required documents is not cleared before price bid opening. If the tender is to be submitted through e-procurement portal, then the above required document is to be uploaded on the portal.

23. PREFERENCE TO MAKE IN INDIA

This procurement shall be governed by notification no. P-45021/2/2017-PP (BE-II) dated 16.09.2020 of Government of India issued by DPIIT and subsequent circulars issued afterwards. Accordingly, the minimum local content, the margin of purchase preference and the procedure for purchase preference to make in India shall be adhered.

24. RESTRICTIONS UNDER RULE 144(XI) OF THE GENERAL FINANCIAL RULES (GFRs), 2017

All provisions of Order No. F.No.6/18/2019-PPD of Department of Expenditure (DoE) shall be applicable for this tender enquiry (Order copy is available at <https://doe.gov.in/procurementpolicy-divisions>). Accordingly, any bidder from a country which shares a land border with India (except the countries to which the Govt. of India has extended lines of credit or in which the Govt. of India is





General Contract Conditions (GCC) of MM Tenders

BHARAT HEAVY ELECTRICALS LIMITED

Industrial Valve Plant: 433, Industrial Complex,
Goindwal Sahib, Dist. Tarn Taran,
Punjab-143422 (INDIA)

engaged in development projects for which list is available at <https://www.mea.gov.in/>) will be eligible to bid in this tender only if the bidder is registered with the Competent Authority as specified in Annex I of the said Order of DoE.

Updated list of the countries to which lines of credit have been extended or in which development projects are undertaken are available on the Ministry of External affairs website (<https://www.mea.gov.in/>)

For the purpose of this order, definition of Bidder from a country which shares a land border with India shall be same as defined in the Annex III of the said order.

Registration with the competent authority as stipulated in the said order is responsibility of bidder. **Bidder has to submit a certificate certifying following along with offer:**

"I have read the clause regarding restrictions on procurement from a bidder of a country which shares a land border with India; I certify that bidder (.... Name of Bidder) is not from such a country or, if from such a country, has been registered with the Competent Authority. I hereby certify that bidder (.....Name of bidder) fulfils all requirements in this regard and is eligible to be considered"

If the bidder is from such country which shares a land border with India evidence of valid registration by the Competent Authority shall also be attached along with offer."

25. DISPUTES

In the event of any dispute and/or difference arising between the Vendor and BHEL as to interpretation and/or execution of the contract and/or the respective rights and liabilities of the parties, such disputes and/or differences shall be referred to the sole arbitrator nominated by BHEL. The provisions of the Indian Arbitration Act and the rules there under shall apply to such arbitration. The award passed by the arbitrator shall be final and conclusively binding on all the parties.

26. JURISDICTION

The court of the place from where the purchase order is issued during the contractual period shall alone have jurisdiction to decide any dispute arising out of or in connection with the purchase order.

27. BANNED FIRMS

The offers of the bidders who are on the banned list as also the offer of the bidders, who engage in the services of the banned firms, shall be rejected. The list of banned firms is available on BHEL website <https://www.bhel.com/>.

28. FRAUD PREVENTION POLICY

The Bidder along with its associate / collaborators / sub-contractors / sub-vendors / consultants / service providers shall strictly adhere to BHEL Fraud Prevention Policy displayed on BHEL website <https://www.bhel.com/> and shall immediately bring to the notice of BHEL management about any fraud or suspected fraud as soon as it comes to their notice.



General Contract Conditions (GCC) of MM Tenders

BHARAT HEAVY ELECTRICALS LIMITED

Industrial Valve Plant: 433, Industrial Complex,
Goindwal Sahib, Dist. Tarn Taran,
Punjab-143422 (INDIA)

29. PREVENTIVE CHECKS TO ELIMINATE SUSPECTED CARTEL FORMATION

The Bidder declares that they will not enter into any illegal or undisclosed agreement or understanding, whether formal or informal with other Bidder(s). This applies in particular to prices, specifications, certifications, subsidiary contracts, submission or non-submission of bids or any other actions to restrict competitiveness or to introduce cartelization in the bidding process. In case, the Bidder is found having indulged in above activities, suitable action shall be taken by BHEL as per extant policies/ guidelines.

30. SUSPENSION OF BUSINESS DEALINGS WITH DEFAULTERS

The offers of the bidders who are under suspension as also the offers of the bidders, who engage the services of the banned firms, shall be rejected. The list of banned firms is available on BHEL web site <https://www.bhel.com/>.

1.0 Integrity commitment, performance of the contract and punitive action thereof:

1.1. Commitment by BHEL:

BHEL commits to take all measures necessary to prevent corruption in connection with the tender process and execution of the contract. BHEL will during the tender process treat all Bidder(s) in a transparent and fair manner, and with equity.

1.2. Commitment by Bidder/ Supplier/ Contractor:

1.2.1. The bidder/ supplier/ contractor commits to take all measures to prevent corruption and will not directly or indirectly influence any decision or benefit which he is not legally entitled to nor will act or omit in any manner which tantamount to an offence punishable under any provision of the Indian Penal Code, 1860 or any other law in force in India.

1.2.2. The bidder/ supplier/ contractor will, when presenting his bid, disclose any and all payments he has made, and is committed to or intends to make to agents, brokers or any other intermediaries in connection with the award of the contract and shall adhere to relevant guidelines issued from time to time by Govt. of India/ BHEL.

1.2.3. The bidder/ supplier/ contractor will perform/ execute the contract as per the contract terms & conditions and will not default without any reasonable cause, which causes loss of business/ money/ reputation, to BHEL.

If any bidder/ supplier/ contractor during pre-tendering/ tendering/ post tendering/ award/ execution/ post-execution stage indulges in mal-practices, cheating, bribery, fraud or and other misconduct or formation of cartel so as to influence the bidding process or influence the price or acts or omits in any manner which tantamount to an offence punishable under any provision of the Indian Penal Code, 1860 or any other law in force in India, then, action may be taken against such bidder/ supplier/ contractor as per extant guidelines of the company available on <https://www.bhel.com/> and/or under applicable legal provisions





General Contract Conditions (GCC) of MM Tenders

BHARAT HEAVY ELECTRICALS LIMITED

Industrial Valve Plant: 433, Industrial Complex,
Goindwal Sahib, Dist. Tarn Taran,
Punjab-143422 (INDIA)

31. GENERAL

1. BHEL will not be bound by any power of attorney granted by the vendors or by changes in the composition of the firm made subsequent to the execution of the contract. They may, however, recognize such power of attorney and changes after obtaining proper legal advice, the cost of which will be chargeable to the vendor concerned.
2. BHEL reserves the right to extend the due date of opening, which shall be informed. Validity of offer shall be deemed to be revised accordingly.
3. BHEL reserves the right to accept or reject any part or whole of the tender of a bidder by assigning a valid reason thereof. BHEL reserves the right to cancel the tender without assigning any reason thereof and without any obligation before any commitment.
4. Acceptance of all terms and conditions, in the form of signed copy of T&C or confirmation separately written, shall be submitted along with quotation. If nothing is mentioned, it shall be concluded that terms and conditions are acceptable.
5. BHEL may increase/decrease item/s based on BHEL requirement before price bid opening. Suitable price implication may be asked from suppliers.
6. BHEL may drop item/items from tender at any stage of tender before placing PO. BHEL may also delete PO with consent with supplier within delivery date of PO.
7. After releasing PO, it is assumed that supplier has accepted PO if we do not receive acknowledgement from supplier within 5 days of date of PO.
8. In case of unscheduled holiday on opening day of tender, the next working day will be treated as scheduled prescribed day of opening of tender.
9. On the due date of tender opening, only technical bids will be opened. The opened technical bids will be evaluated by us and clarifications required, if any, will be called for from the bidders on technical and commercial points. If no reply is received from the vendor for the clarification raised by BHEL with in the final cut-off date, those vendors offer will be processed with the documents available / submitted against this tender. Offers not meeting the required specification and technical condition will be summarily rejected. The price bids of technically suitable bidders will be opened on a later date with prior intimation to techno-commercially suitable bidders.
10. Ranking L-1, L-2 etc. shall be done for individual item for the techno-commercially acceptable offers on landed cost to BHEL, IVP Goindwal basis and BHEL reserves the right to place order for individual items with different vendors.
11. BHEL reserves the right to negotiate with L1 vendor or re-float the tender for items where, L1 price is not the lowest acceptable price; BHEL reserves the right to increase or decrease the tender quantity.
12. If supplier is mentioning delivery destination within state/ outside state depending upon his location of factory, Free on Road etc. these are assumed as on FOR Goindwal. If supplier is wishing to give delivery on Ex works basis, then he has to clearly mention about it.
13. The bidder has to keep track of any changes by viewing the addendum / Corrigendum's issued by the Purchaser on time-to- time basis in the E-Procurement platform. The Company calling for tenders shall not be responsible for any claims/problems arising out of this.
14. Any term in special tender terms and conditions will supersede the GCC.



9/890-0000-Λ-Σ
DRAWING NO.

SL. No.	DRAWING No.	COMP. CODE	MATL. SPECN.	S		e		m		øD	MATL. MARK	NET WT. (Kg.)
				MAX.	MIN.	MAX.	MIN.	MAX.	MIN.			
01	3.V.N073.06876/03	96 456 279	ASTM A194 - 2H, CERTIFY	22.22	21.59	25.65	24.61	12.80	11.79	1/2"-13 UNC -2B	2H	0.02
02	3.V.N025.06876/03	96 456 280		26.97	26.19	31.17	29.85	16.03	14.91	5/8"-11 UNC -2B	2H	0.03
03	3.V.N057.06876/03	96 456 281		31.75	30.78	36.65	35.10	19.25	18.03	3/4"-10 UNC -2B	2H	0.08
04	3.V.N065.06876/03	96 456 282		41.28	40.01	47.65	45.62	25.70	24.28	1"-8 UNC -2B	2H	0.17
05	3.V.N105.06876/03	96 456 283		46.02	44.60	53.16	50.85	29.93	27.41	1.1/8"-8 UN -2B	2H	0.27
06	3.V.N206.06876/02	96 456 431		36.52	35.41	42.16	40.37	22.47	21.16	7/8"-9 UNC -2B	2H	0.11
07	3.V.N204.06876/02	96 456 453	SA 307 Gr.B CERTIFY	31.75	30.78	36.65	35.10	19.25	18.03	3/4"-10 UNC -2B	307 B	0.08
08	3.V.N207.06876/02	96 456 454		36.52	35.41	42.16	40.37	22.47	21.16	7/8"-9 UNC -2B	307 B	0.11
09	3.V.F505.06876/01	96 456 683	ASTM A194 - 2H, CERTIFY	50.8	49.23	58.65	56.11	31.78	30.15	1.1/4"-8 UN -2B	2H	0.22
10	3.V.N848.06876	96 453 667		55.57	53.8	64.16	61.37	35.0	33.27	1.3/8"-8 UN -2B	2H	0.42
11	3.V.N827.06876	96 453 668		60.33	58.42	69.65	66.59	38.23	36.40	1.1/2"-8 UN -2B	2H	0.52
12	3.V.N846.06876/01	96 453 669		69.85	67.61	80.65	77.09	44.68	42.65	1.3/4"-8 UN -2B	2H	0.81
13	3.V.NK44.06876	96 465 904		65.07	63.02	75.15	71.84	41.45	39.53	1.5/8"-8 UN -2B	2H	0.68
14	3.V.NK45.06876	96 465 906		79.37	76.84	91.64	87.61	51.13	48.90	2"-8 UN -2B	2H	1.36

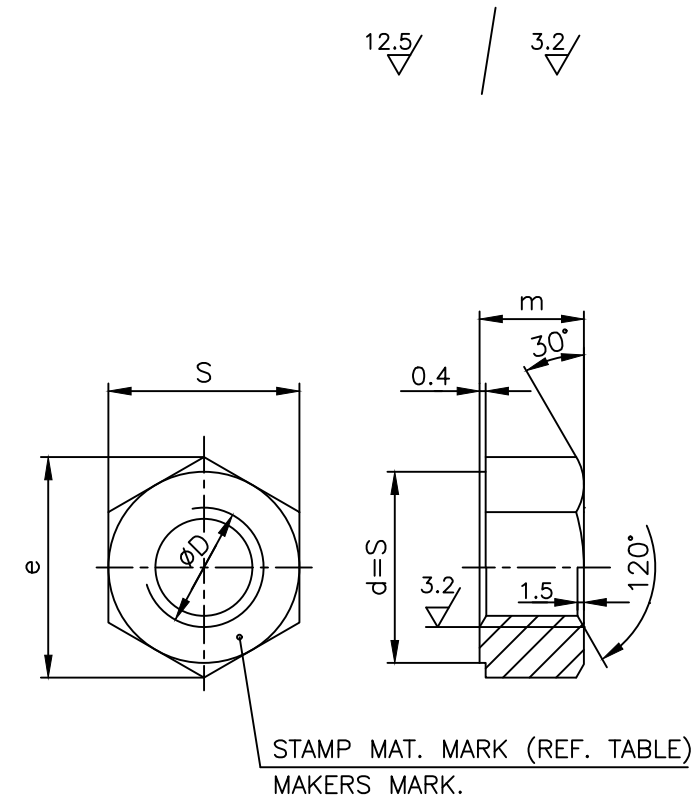

RETRACED WITH REV. 09 ON 26.11.18

NOTE:

1. FOR QUALITY REQUIREMENTS REFER LATEST APPLICABLE STANDARD(TDC:5:164).

NO OFF	DESCRIPTION	MATL CODE	MATL SPECN	HEAT TREATMENT	SCRAP SORT	NET WT (kg)	GROSS WT (kg)	DRAWING No	ITEM No
-	-	-	-	-	-	-	-	-	-

CAUTION: The information on this document is the property of BHARAT HEAVY ELECTRICALS LTD. It must not be used directly or indirectly in any way detrimental to the interest of the company.

TYPE OF PRODUCT OR NAME OF CUSTOMER/PROJECT

BHARAT HEAVY ELECTRICALS LTD.,
UNIT: HIGH PRESSURE BOILER PLANT.
TIRUCHIRAPALLI-620014.

DRN	M.SRINIVASAN	SIGN	DATE	NO.OF VAR.
CHD	N.DHANAPAL		22.04.96	
APPD	A.VISWANATHAN		22.04.96	

DEPT VL
CODE 320

SCALE NTS

WEIGHT (KG). REF. TABLE

REFERENCE INFORMATION CAD: C306876

TITLE **HEX NUT**

CARD CODE U 01

DRAWING NO. **3-V-0000-06876**

NO. OF ITEMS

REV 09

REV	DATE	ALTERED	R.P.SINGH
09	26.11.18	CHD & APPD SSK & KRS	
		SL. No.13 & 14 INCLUDED.	

DRAWING NO. 3-V-0000-23249

SL. No.	DRAWING No.	COMP. CODE	MATL. SPECN.	S		e		m		øD	MATL. MARK	NET WT. (Kg.)
				MAX.	MIN.	MAX.	MIN.	MAX.	MIN.			
01	3-V-F522-23249/02	96 456 888 0000	ASTM A194 - Gr.7	36.52	35.41	42.16	40.37	22.47	21.16	7/8"-9 UNC -2B	GR.7	0.11
02	3-V-F523-23249/02	96 456 889 0000	ASTM A194 - Gr.7	31.75	30.78	36.65	35.10	19.25	18.03	3/4"-10 UNC -2B	GR.7	0.08
03	3-V-F524-23249/02	96 456 890 0000	ASTM A194 - Gr.7	41.28	40.01	47.65	45.62	25.70	24.28	1"-8 UNC -2B	GR.7	0.17
04	3-V-F525-23249/02	96 456 891 0000	ASTM A194 - Gr.7	50.80	49.23	58.65	56.11	31.78	30.15	1.1/4"-8 UN -2B	GR.7	0.27
05	3-V-F526-23249/02	96 456 892 0000	ASTM A194 - Gr.7	46.02	44.60	53.16	50.85	29.93	27.41	1.1/8"-8 UN -2B	GR.7	0.22
06	3-V-0001-23249	96 465 648 0000	ASTM A194 - Gr.8M	22.22	21.59	25.65	24.61	12.80	11.79	1/2"-13 UNC -2B	GR.8M	0.02
07	3-V-0002-23249	96 465 649 0000	ASTM A194 - Gr.8M	26.97	26.19	31.17	29.85	16.03	14.91	5/8"-11 UNC -2B	GR.8M	0.03
08	3-V-0003-23249	96 465 650 0000	ASTM A194 - Gr.8M	31.75	30.78	36.65	35.10	19.25	18.03	3/4"-10 UNC -2B	GR.8M	0.08
09	3-V-0004-23249	96 465 651 0000	ASTM A194 - Gr.8M	36.52	35.41	42.16	40.37	22.47	21.16	7/8"-9 UNC -2B	GR.8M	0.11
10	3-V-0005-23249	96 465 652 0000	ASTM A194 - Gr.8M	41.28	40.01	47.65	45.62	25.70	24.28	1"-8 UNC -2B	GR.8M	0.17
11	3-V-0006-23249	96 465 653 0000	ASTM A194 - Gr.8M	46.02	44.60	53.16	50.85	29.93	27.41	1.1/8"-8 UN -2B	GR.8M	0.22
12	3-V-0007-23249	96 465 654 0000	ASTM A194 - Gr.8M	50.80	49.23	58.65	56.11	31.78	30.15	1.1/4"-8 UN -2B	GR.8M	0.27
13	3-V-0008-23249	96 465 847 0000	ASTM A194 - Gr.2HM	22.22	21.59	25.65	24.61	12.80	11.79	1/2"-13 UNC -2B	GR.2HM	0.02
14	3-V-0009-23249	96 465 848 0000	ASTM A194 - Gr.2HM	26.97	26.19	31.17	29.85	16.03	14.91	5/8"-11 UNC -2B	GR.2HM	0.03
15	3-V-0010-23249	96 465 849 0000	ASTM A194 - Gr.2HM	31.75	30.78	36.65	35.10	19.25	18.03	3/4"-10 UNC -2B	GR.2HM	0.08
16	3-V-0011-23249	96 465 850 0000	ASTM A194 - Gr.2HM	36.52	35.41	42.16	40.37	22.47	21.16	7/8"-9 UNC -2B	GR.2HM	0.11
17	3-V-0012-23249	96 465 851 0000	ASTM A194 - Gr.2HM	41.28	40.01	47.65	45.62	25.70	24.28	1"-8 UNC -2B	GR.2HM	0.17
18	3-V-0013-23249	96 465 852 0000	ASTM A194 - Gr.2HM	46.02	44.60	53.16	50.85	29.93	27.41	1.1/8"-8 UN -2B	GR.2HM	0.22
19	3-V-0014-23249	96 465 853 0000	ASTM A194 - Gr.2HM	50.80	49.23	58.65	56.11	31.78	30.15	1.1/4"-8 UN -2B	GR.2HM	0.27
20	3-V-0015-23249	96 465 940 0000	ASTM A194 - Gr.8M	55.57	53.8	64.16	61.37	35.0	33.27	1.3/8"-8 UN -2B	GR.8M	0.42

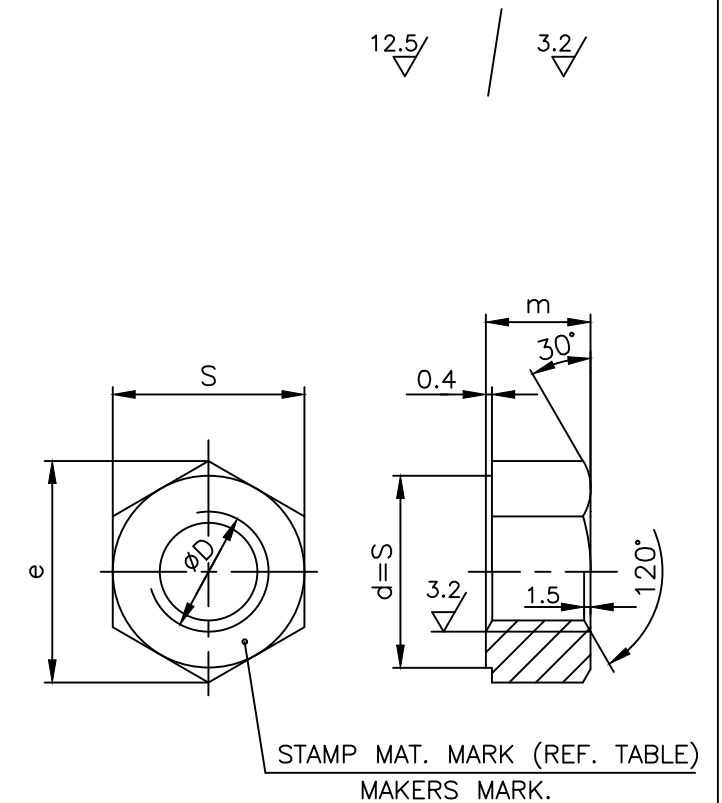

NOTE:

- FOR QUALITY REQUIREMENTS REFER LATEST APPLICABLE QUALITY PROCEDURE.
- SUITABLE OIL PRESERVATIVE SHALL BE APPLIED.

-	-	-	-	-	-	-	-	-	-	-
NO OFF	DESCRIPTION	MATL CODE	MATL SPECN	HEAT TREATMENT	SCRAP SORT	NET WT (kg)	GROSS WT (kg)	DRAWING No	ITEM No	

TYPE OF PRODUCT OR NAME OF CUSTOMER/PROJECT

<p>BHARAT HEAVY ELECTRICALS LTD., UNIT: HIGH PRESSURE BOILER PLANT. TIRUCHIRAPALLI-620014.</p>	DRN	M.SRINIVASAN	SIGN	DATE	NO.OF VAR.
	CHD	N.DHANAPAL		23.04.96	
	APPD	A.VISWANATHAN		23.04.96	

REV	DATE	ALTERED	R.P.SINGH
05	03.03.21	CHD & APPD	SAMEER & SSK

SL. No. 20 INCLUDED.

CAUTION: The information on this document is the property of BHARAT HEAVY ELECTRICALS LTD. It must not be used directly or indirectly in any way detrimental to the interest of the company.

DEPT	VL	SCALE	WEIGHT (KG).	REFERENCE INFORMATION	NO. OF ITEMS
CODE	320	NTS	REF. TABLE	CAD: F323249	
TITLE	HEX NUT		CARD CODE	DRAWING NO.	REV
			U 01	3-V-0000-23249	05

3-V-0000-25684
DRAWING NO.

12.5 3.2

SL. No.	DRAWING NUMBER	MATERAIL CODE	MATL.SPECN.	THREAD SIZE	NET Wt.(kg)	DIMENSIONS						* MATL. MARK	APPLICABLE VALVES
						L	b	r	S-h12	ød-D11	øD		
01	3-V-0001-25684	96 465 773 0000	ASTM A193-B8M CL.2. CERTIFY	1/2"-13UNC-2A	0.061	50	30	6	14	13.5	25	B8M	2"-150C
02	3-V-0002-25684	96 465 774 0000		1/2"-13UNC-2A	0.07	60	30	6	14	13.5	25	B8M	2" & 3"/150C 3"/300C
03	3-V-0003-25684	96 465 775 0000		1/2"-13UNC-2A	0.08	75	40	6	14	13.5	25	B8M	3" & 4"-600C
04	3-V-0004-25684	96 465 776 0000		1/2"-13UNC-2A	0.09	90	30	6	14	13.5	25	B8M	2"-600C
05	3-V-0005-25684	96 465 777 0000		5/8"-11UNC-2A	0.16	75	38	6	17	17	32	B8M	4"/150C 4"/300C
06	3-V-0006-25684	96 465 771 0000		5/8"-11UNC-2A	0.18	90	38	6	17	17	32	B8M	6",8" & 12"/150C 6" & 8"-300C
07	3-V-0007-25684	96 465 778 0000		5/8"-11UNC-2A	0.20	100	38	6	17	17	32	B8M	10"/150C & 10"/300C
08	3-V-0008-25684	96 465 779 0000		5/8"-11UNC-2A	0.22	110	40	6	17	17	32	B8M	4"-900C
09	3-V-0009-25684	96 465 780 0000		5/8"-11UNC-2A	0.26	130	50	6	17	17	32	B8M	14",16" & 20"/150C
10	3-V-0010-25684	96 465 781 0000		5/8"-11UNC-2A	0.31	160	50	6	17	17	32	B8M	24"/150C
11	3-V-0011-25684	96 465 845 0000		5/8"-11UNC-2A	0.28	140	50	6	17	17	32	B8M	10"/300C

DIMENIONS	h12	D11
10 TO 18	0	+0.160
	-0.180	+0.050

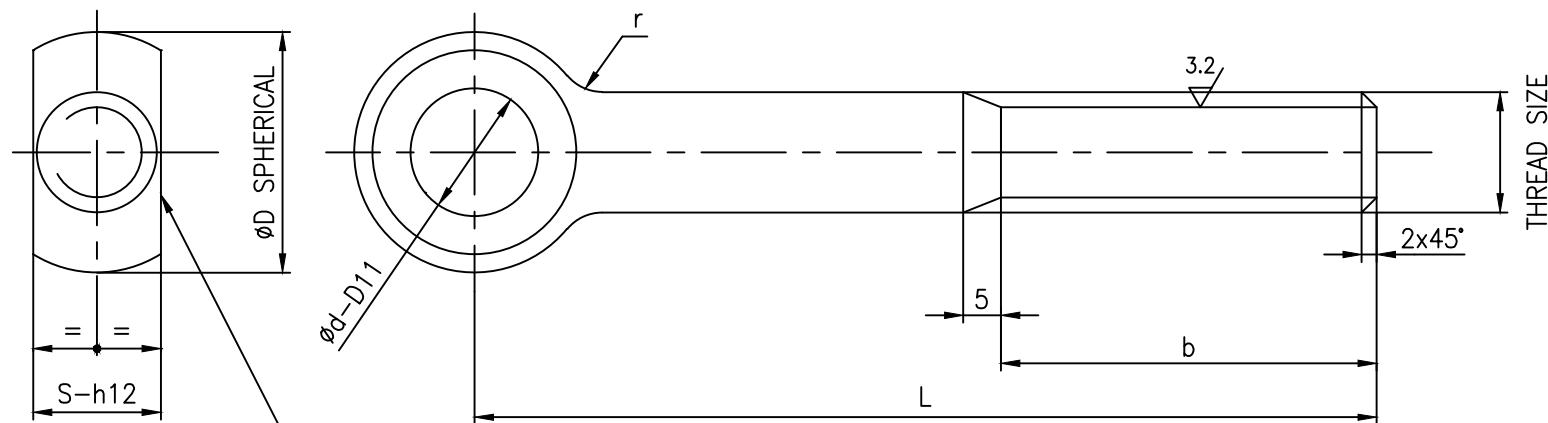

PUNCH MATL.MARK *

NOTES:

1. EYE BOLT TO BE MADE OUT OF FORGING.

REV	DATE	ALTERED	R.P.SINGH	REV	DATE	ALTERED	T.SANGEETHA
02	07.07.18	CHD & APPD	SSK & KRS	01	22.05.17	CHD & APPD	SSK & KRS
SL. No. 11 INCLUDED				MATL.MARK B8M WAS B8			

CAUTION: The information on this document is the property of BHARAT HEAVY ELECTRICALS LTD. It must not be used directly or indirectly in any way detrimental to the interest of the company.

NO OFF	DESCRIPTION	MATL CODE	MATL SPECN	HEAT TREATMENT	SCRAP SORT	NET WT (kg)	GROSS WT (kg)	DRAWING No	ITEM No
TYPE OF PRODUCT OR NAME OF CUSTOMER/PROJECT									
BHARAT HEAVY ELECTRICALS LTD., UNIT: HIGH PRESSURE BOILER PLANT. TIRUCHIRAPALLI-620014.					DRN	R.ANITHA	SIGN	DATE	NO.OF VAR.
					CHD	S.SATHEESKUMAR		10.09.16	-
					APPD	K.RAJASEKARAN		10.09.16	-
DEPT	VL	SCALE	WEIGHT (KG).	REFERENCE INFORMATIONS			NO. OF ITEMS		
CODE	320	NTS.	-	CAD:C325684			-		
TITLE						CARD CODE	DRAWING NO.	REV	
EYE BOLT						U 01	3-V-0000-25684	02	

3-V-0000-35002
DRAWING NO.

12.5 / 3.2

Sl. No.	DRAWING NUMBER	MATERIAL CODE	MATERIAL SPECIFICATION	SIZE	DIMENSIONS										
					MD	∅d1	∅d2	∅d3	L	S	E	K	X	WEIGHT	SIZE/RATING
01	3-V-0001-35002/1	964658950000	ASTM A193-B8M CL.2, CERTIFY	M24X195X60	M24	26	37	45	195	60	25	2.5	5	0.8	350/600
02	3-V-0002-35002/1	964658980000		M20X140X60	M20	21	36	40	140	60	22	2.5	5	0.44	800/150
03	3-V-0003-35002/1	964658990000		M20X150X60	M20	21	36	40	150	60	22	2.5	5	0.47	300/300

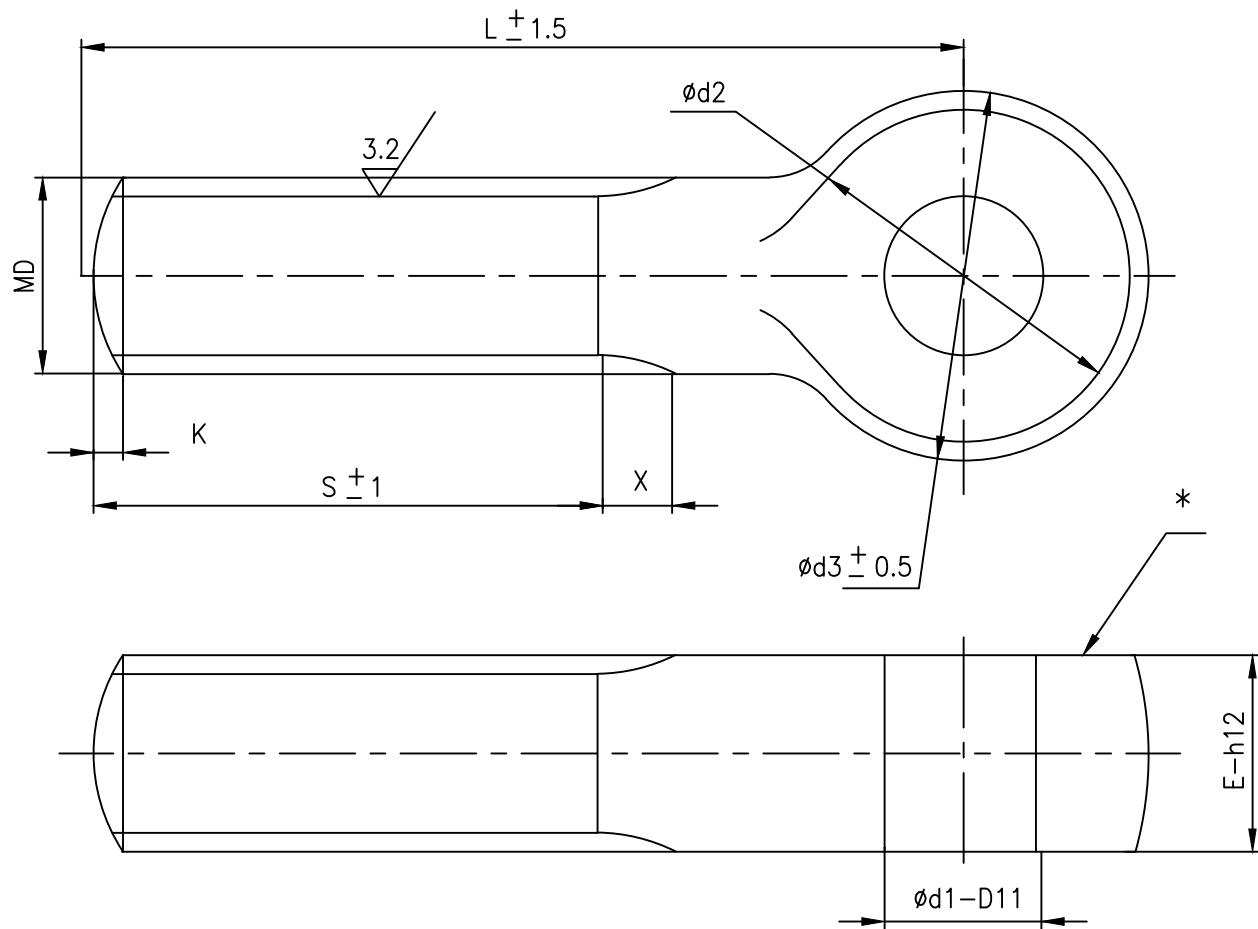

NOTES:

1. EYE BOLT SHOULD BE MADE OUT OF FORGING.
2. * PUNCH MATERIAL MARK "B8M"
3. QUALITY REQUIREMENTS SHALL BE AS PER LATEST TDC.
BLACKENING SHALL BE DONE INSTEAD OF CADMIUM PLATING.

NO OFF	DESCRIPTION	MATL CODE	MATL SPECN	HEAT TREATMENT	SCRAP SORT	NET WT (kg)	GROSS WT (kg)	DRAWING No	ITEM No
--------	-------------	-----------	------------	----------------	------------	-------------	---------------	------------	---------

TYPE OF PRODUCT OR NAME OF CUSTOMER/PROJECT



BHARAT HEAVY ELECTRICALS LTD.,
UNIT: HIGH PRESSURE BOILER PLANT.
TIRUCHIRAPALLI-620014.

DRN	NAME	SIGN	DATE	NO.OF VAR.
	R.P.SINGH		29.10.18	
CHD	S.SATHEESKUMAR		29.10.18	
APPD	K.RAJASEKARAN		29.10.18	

REV	DATE	ALTERED	R.P.SINGH
01	26.06.20	CHD & APPD SAMEER & SSK	

MATL. SPECIFICATION UPDATED.

CAUTION: The information on this document is the property of BHARAT HEAVY ELECTRICALS LTD. It must not be used directly or indirectly in any way detrimental to the interest of the company.

DEPT	SCALE	WEIGHT (KG)	REFERENCE INFORMATION	NO. OF ITEMS
VL	N T S	REF.TABLE		
CODE 320				
TITLE	CARD CODE	DRAWING NO.	REV	
EYE BOLT	U 01	3-V-0000-35002	01	

11 / 08890-0000-A-Σ
DRAWING NO. ON REVERSE

12.5 3.2

SL. No.	DRAWING NUMBER	MATERIAL CODE	MATL.SPECN.	THREAD SIZE	NET Wt.(kg)	DIMENSIONS						* MATL. MARK	APPLICABLE VALAVES
						L	b	r	S-h12	ød-D11	øD		
01	3-V-N073-06880/04	96 456 263 0000	ASTM A193-B7, HT, CERTIFY	1/2"-13UNC-2A	0.07	60	30	6	14	13.5	25	B7	2" & 3"/150C 3"/300C
02	3-V-N033-06880/04	96 456 264 0000		5/8"-11UNC-2A	0.16	75	38	6	17	17	32	B7	4"/150C 4"/300C
03	3-V-N001-06880/04	96 456 265 0000		5/8"-11UNC-2A	0.18	90	38	6	17	17	32	B7	6",8" & 12"/150C 6" & 8"-300C
04	3-V-N057-06880/04	96 456 266 0000		5/8"-11UNC-2A	0.23	120	38	6	17	17	32	B7	10"/150C
05	3-V-N206-06880/03	96 456 397 0000		5/8"-11UNC-2A	0.20	100	38	6	17	17	32	B7	10"/150C & 10"/300C
06	3-V-N224-06880/03	96 456 230 0000		5/8"-11UNC-2A	0.26	130	50	6	17	17	32	B7	14",16" & 20"/150C
07	3-V-C329-06880/03	96 456 432 0000		5/8"-11UNC-2A	0.22	110	40	6	17	17	32	B7	4"-900C
08	3-V-F503-06880/01	96 456 679 0000		1/2"-13UNC-2A	0.08	75	40	6	14	13.5	25	B7	3" & 4"-600C
09	3-V-N361-06880/01	96 456 690 0000		5/8"-11UNC-2A	0.31	160	50	6	17	17	32	B7	24"/150C
10	3-V-N201-06880/01	96 456 818 0000		1/2"-13UNC-2A	0.061	50	30	6	14	13.5	25	B7	2"-150C
11	3-V-M768-06880/01	96 456 853 0000	A320-Gr.L7 HT,CERTIFY	1/2"-13UNC-2A	0.07	60	30	6	14	13.5	25	L7	2" & 3"/300C 3"/150C
12	3-V-M769-06880/01	96 456 854 0000		5/8"-11UNC-2A	0.16	75	38	6	17	17	32	L7	4"/150C 4"/300C
13	3-V-M770-06880/01	96 456 855 0000		5/8"-11UNC-2A	0.18	90	38	6	17	17	35	L7	6" & 8"-300C 6" & 8"-150C
14	3-V-F501-06880	96 465 083 0000	A193-B7 HT,CERTIFY	1/2"-13UNC-2A	0.09	90	30	6	14	13.5	25	B7	2"-600C

DIMENSIONS	h12	D11
10 TO 18	0	+0.160
	-0.180	+0.050

NOTES:

1. EYE BOLT TO BE MADE OUT OF FORGING.

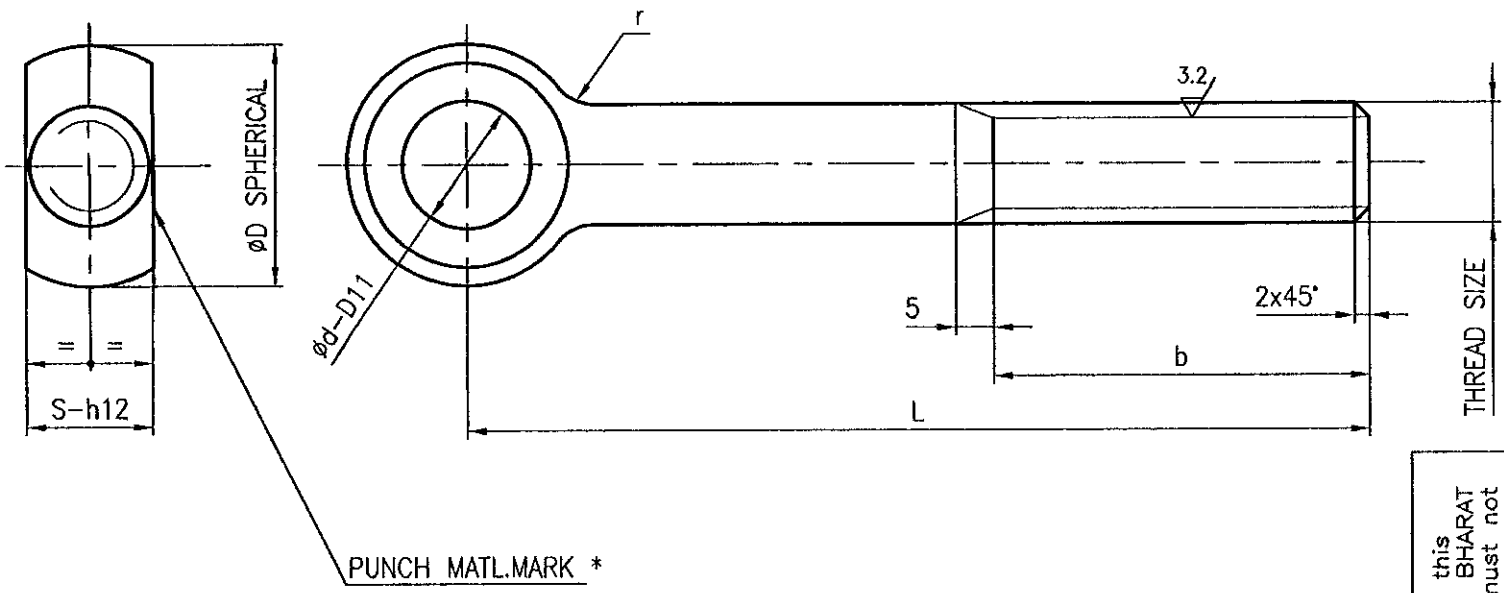

DRAWING RETRACED WITH REVISION 11 ON 12.06.01 (REFER DCN.HM:393)

NO OFF	DESCRIPTION	MATL CODE	MATL SPECN	HEAT TREATMENT	SCRAP SORT	NET WT (kg)	GROSS WT (kg)	DRAWING No	ITEM No
	TYPE OF PRODUCT OR NAME OF CUSTOMER/PROJECT	CS							
	BHARAT HEAVY ELECTRICALS LTD. UNIT: HIGH PRESSURE BOILER PLANT. TIRUCHIRAPALLI 620014.	DRN	K.P.LEON	SIGN	[Signature]	DATE	12.06.01	NO.OF VAR.	
		CHD	T.R.R.MURTHY	SIGN	[Signature]	DATE	12.06.01		
		APPD	P.Boomnathan	SIGN	[Signature]	DATE	12.06.01		
	DEPT VL			SCALE		WEIGHT (KG)		REFERENCE INFORMATION	NO. OF ITEMS
	CODE 320			NTS.		-		CAD:C306880	-
	TITLE	EYE BOLT		CARD CODE	U 01	DRAWING NO.	3-V-0000-06880	REV	11

CAUTION: The information on this document is the property of BHARAT HEAVY ELECTRICALS LTD. It must not be used directly or indirectly in any way detrimental to the interest of the company.

REV	DATE	ALTERED
11	02.07.97	CHD & APPD

SL.NO.14 INCLUDED

FOR TOLERANCES OF UNTOLERANCED DIMENSIONS

ALL DIMENSIONS ARE IN MILLIMETRES. DURING MANUFACTURE REFER RELEVANT QCP/QP

CAUTION: The information on this document is the property of BHARAT HEAVY ELECTRICALS LTD. It must not be used directly or indirectly in any way detrimental to the interest of the company.

REV 01	DATE 29.10.18	ALTERED CHD & APPD	R.P.SINGH SSK & KRS	REV	DATE	ALTERED
				CHD & APPD		
MATERIAL SPECIFICATION CHANGED FROM B8MA TO Gr.8M				GROUP No. 0006 & 0007 ADDED		

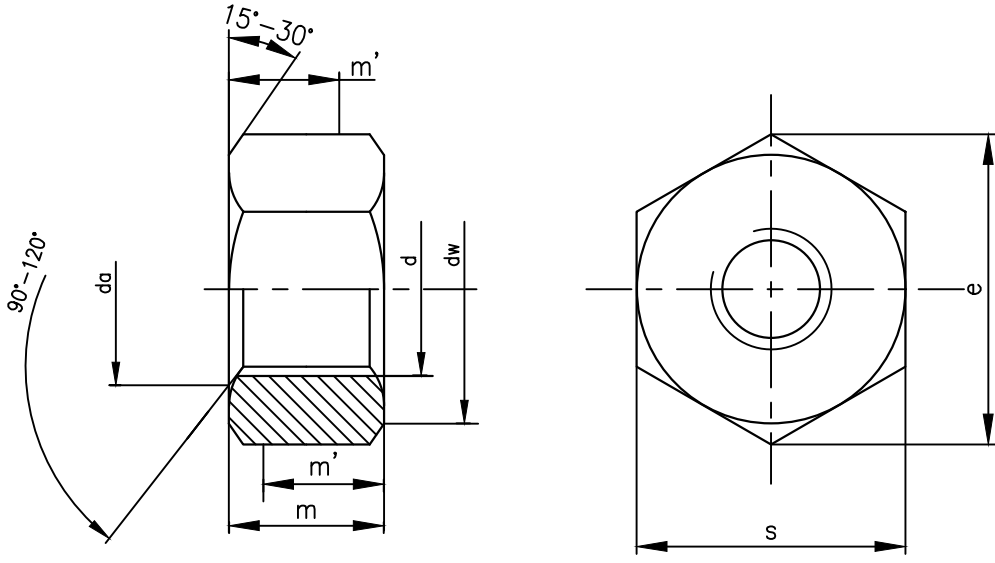

NOTE:- FOR OTHER DIMENSIONS/DETAILS REFER IS:1364.

MATERIAL CODE	DRAWING NO	Thread Size	da		dw	e	m		m'		S		WEIGHT
			d	Min	Max	Min	Min	Max	Min	Max	Min	Max	
964658380000	4-V-0001-27368	M10	10	10.8	14.6	17.77	10	9.64	7.7	16	15.73	0.0108	
964658390000	4-V-0002-27368	M20	20	21.6	27.7	32.95	20.7	19.40	15.5	30	29.16	0.0645	
964658400000	4-V-0003-27368	M27	27	29.16	38	45.2	24.7	22.6	18.1	41	40	0.185	
964658410000	4-V-0004-27368	M30	30	32.4	42.7	50.85	30.7	29.10	23.3	46	45	0.253	
964658440000	4-V-0005-27368	M12	12	13.0	16.6	20.03	12	11.57	9.30	18	17.73	0.0165	
964658970000	4-V-0006-27368	M33	33	35.6	46.6	55.37	33	31.4	25.1	50	49	0.30	
964658960000	4-V-0007-27368	M24	24	25.9	33.2	39.55	24.2	22.9	18.3	36	35	0.11	

HEXAGON NUT		ASTM A194 Gr.8M, CERTIFY												
NO OFF	DESCRIPTION	MATL CODE	MATL SPECN	HEAT TREATMENT	SCRAP SORT	NET WT (kg)	GROSS WT (kg)	DRAWING No		ITEM No				
		BHARAT HEAVY ELECTRICALS LTD., UNIT: HIGH PRESSURE BOILER PLANT. TIRUCHIRAPALLI 620014.				DRN	NAME R.P.SINGH		SIGN	DATE 16.04.18	NO.OF VAR			
						CHD	S.SATHEES			16.04.18				
						APPD	K.RAJASEKARAN			16.04.18				
DEPT VL		SCALE		WEIGHT (KG).		REFERENCE INFORMATIONS				NO. OF ITEMS				
CODE 320		NTS		REFER TABULATION		---								
TITLE HEX NUT					CARD CODE U 01	DRAWING NO. 4-V-0000-27368					REV 01			

FOR TOLERANCES OF UNTOLERANCED DIMENSIONS

ALL DIMENSIONS ARE IN MILLIMETRES.
DURING MANUFACTURE REFER RELEVANT QCP/QP

CAUTION: The information on this document is the property of BHARAT HEAVY ELECTRICALS LTD. It must not be used directly or indirectly in any way detrimental to the interest of the company.

REV 01	DATE 02.04.94	ALTERED CHD & APPD
1.CHANGED TO SUB DELIVERY COMPONENT, CODE, MATL CHANGED.		
2.REFER DCN NO: CS: 0296		
REV 02	DATE 06.07.17	ALTERED: D.JEYASRI CHD & APPD: SSK & KRS
DIMENSIONS $\phi 13h11$ WAS $\phi 12D11$		

~ / $\sqrt{12.5} / \sqrt{3.2}$

$\phi 13 h11$	0
	-0.110

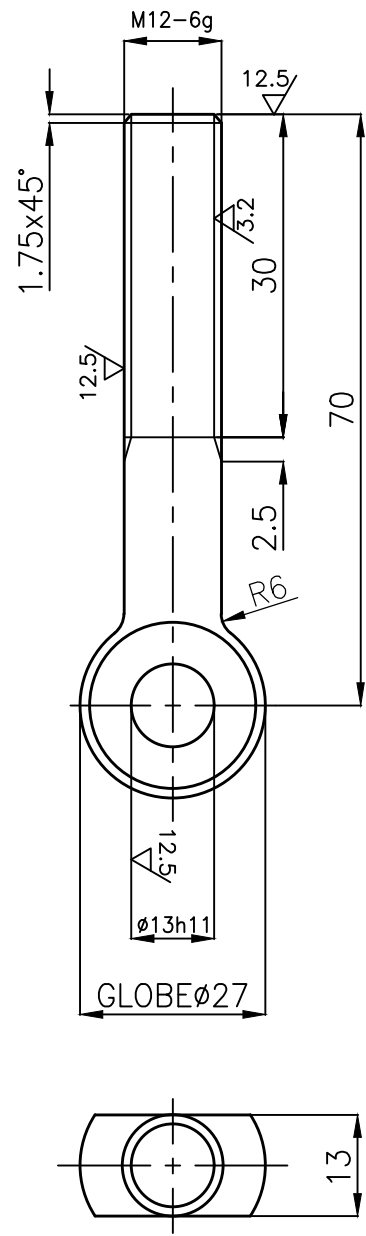

NOTE:

1. PUNCH MATERIAL MARK-B7
2. FOR QUALITY REQUIREMENT REFER LATEST TDC:5:164

2480
2479
2478
2477
2476
APPLICABLE TYPE NOS

01		964563960000	ASTM A193-B7	HT		0.08				
NO OFF	DESCRIPTION	MATL CODE	MATL SPECN	HEAT TREATMENT	SCRAP SORT	NET WT (kg)	GROSS WT (kg)	DRAWING No	ITEM No	
					NAME D.JEYASRI SIGN DATE 07.07.17 NO.OF VAR					
BHARAT HEAVY ELECTRICALS LTD., UNIT: HIGH PRESSURE BOILER PLANT. TIRUCHIRAPALLI 620014.					CHD S.SATHEES KUMAR DATE 07.07.17					
					APPD K.RAJASEKARAN DATE 07.07.17					
DEPT VL			SCALE	WEIGHT (KG).	REFERENCE INFORMATION					NO. OF ITEMS
CODE 320			N T S							
TITLE					CARD CODE	DRAWING NO.				REV
EYE BOLT (M12X70)					U 01	4-V-2476-04073				02



PLANT STANDARD

HPBP TIRUCHIRAPALLI

BPS:41320

PAGE 1 of 3

Based on IS: 1364 (part 3)

HEXAGON NUTS, PRODUCT GRADE A (Property Class 8)

1.0 SCOPE:

Covers the requirement of Hexagon Nuts in the size range M3 to M16.

2.0 SPECIFICATION AND REFERENCE STANDARDS

Dimensions and preferred sizes		Table 1 of this standard
Tolerance	Product grade	A
	Indian Standard	IS: 1367(part 2)
Thread	Pitch	Coarse
	Tolerance	6H
	Indian Standard	IS: 4218(part 3, 5 & 6)
Material		Steel
Mechanical properties	Property class	8
	Indian Standard	IS: 1367 (Part 6)
Sampling and Acceptability	Indian Standard	IS: 2614
General requirements	Nuts shall comply with IS: 1364 in respect of requirements not covered in this standard	

2.1 Referred Standards (only the relevant parts of current versions are applicable).

IS: 1364 Specification for Hexagon Head Bolts, Screws & Nuts.
(Part 3) of product grade A & B, Part 3 Hexagonal Nuts.

IS: 1367 Technical supply conditions for threaded steel fasteners.

IS: 2614 Method of sampling fasteners.

IS: 4218 ISO metric screw threads.

Revisions			Approved STANDARDS SECTION ENGINEERING AND DEVELOPMENT CENTER HPBP TIRUCHIRAPALLI		
Rev. No.	Amd. No.	Reaffirmed	PREPARED	Issued	Dt of 1st Issue
Dt.	Dt.	Year	HPBP TIRUCHY	STANDARD /ENGG	

COPYRIGHT AND CONFIDENTIAL
The information on this document is the property of BHARAT HEAVY ELECTRICAL LIMITED. It must not be used directly or indirectly in any way detrimental to the interest of the company.



PLANT STANDARD

HPBP TIRUCHIRAPALLI

BPS: 41320

PAGE 2 of 3

3.0 DESIGNATION

A Grade-A Hexagonal Nut to this standard of thread size M6 shall be designated as:

3.1 On Drawings

- 1) Material Specification column : IS: 1364
- 2) Description Column : NUT HEX GR A 8-M6
- 3) Drawing Number column : 4132006000
- 4) Material code Column : 4132000006

3.2 Ordering Description

For placing indents, issuing enquiries and on Purchase order, the Ordering Description given below shall be followed:

Hex Nut M6 IS: 1364 (part-3) -8

4.0 ADDITIONAL INFORMATION

- 4.1 For nuts of thread size M20 to M48x3, product grade B, refer BPS: 41301.
- 4.2 For Cadmium plated nuts, refer BPS: 41360

COPYRIGHT AND CONFIDENTIAL

The information on this document is the property of BHARAT HEAVY ELECTRICAL LIMITED. It must not be used directly or indirectly in any way detrimental to the interest of the company.



PLANT STANDARD

HPBP TIRUCHIRAPALLI

BPS: 41320

PAGE 3 of 3

TABLE 1 DIMENSIONS FOR HEXAGONAL NUTS

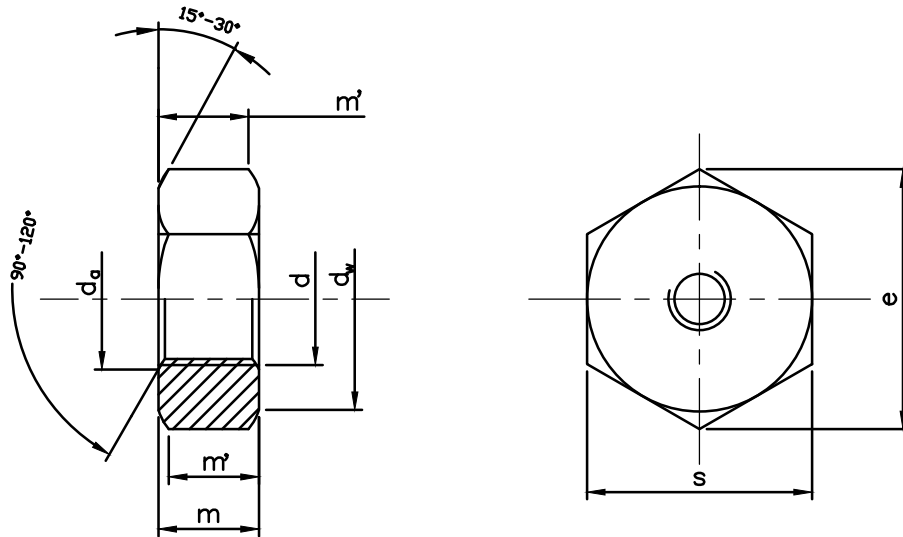

m' = Effective gauging height

(All dimension are in millimeters)

Thread Size d	d_a		d_w Min	e Min	m		m' Min	s		Weight
	Min	Max			Max	Min		Max	Min	
M3	3	3.45	4.6	6.01	2.4	2.15	1.72	5.5	5.32	0.4
M4	4	4.6	5.9	7.66	3.2	2.9	2.32	7	6.78	0.9
M5	5	5.75	6.9	8.79	4.7	4.4	3.52	8	7.78	
M6	6	6.75	8.9	11.05	5.2	4.9	3.92	10	9.78	2.5
M8	8	8.75	11.6	14.38	6.8	6.44	5.15	13	12.73	6.0
M10	10	10.8	14.6	17.77	8.4	8.04	6.43	16	15.73	11.6
M12	12	13.0	16.6	20.03	10.8	10.37	8.30	18	17.73	17.9
M16	16	17.3	22.5	26.75	14.8	14.1	11.28	24	23.67	33.5

NOTE:

1. Weights are given in kg per 1000 numbers only.
2. For stocked sizes refer BPS components booklet.

COPYRIGHT AND CONFIDENTIAL

The information on this document is the property of BHARAT HEAVY ELECTRICAL LIMITED. It must not be used directly or indirectly in any way detrimental to the interest of the company.



भारत हेवी इलेक्ट्रिकल्स लिमिटेड
 (भारत सरकार का उपक्रम)
इंडस्ट्रियल वाल्वस प्लांट
Bharat Heavy Electricals Limited
 (A Govt. of India Undertaking)
Industrial Valves Plant

Standard Quality Assurance Plan for Stainless steel fasteners

BHE:SQAP:SS:01

Dt:12.08.2021

SN	Stage of inspection	Inspection type		Ref doc	Quantum of check	Format of Record	Agency	
							M	BHEL/TPIA
1	Raw material	Chemical/Mechanical properties		Material test certificate	100%	MTC report	V	V
2	Finished product	Chemical Analysis	Chemical composition (for both stud and nut)	Material specification in drawing/PO	one sample per heat	Chemical Test Report	P	W
		Mechanical Properties	Tensile strength	Material specification in drawing/PO	one sample per heat	Mechanical Test Report	P	W
			Yield strength/Proof Load (for both stud and nut)		one sample per heat			
			Elongation		one sample per heat			
			Reduction of area		one sample per heat			
			Hardness (for both stud and nut)		10% or 20 nos.			
Dimension	As per drawing, Thread with GO/ NO GO Gauge (for both stud and nut)	Material drg/BPS	10% or 20 nos/type whichever is lower.	Inspection report	P	P		

अमनप्रीत सिंह / Amanpreet Singh
 उप प्रबंधक / Dy. Manager (QM)
 भारत हेवी इलेक्ट्रिकल्स लिमिटेड
 Bharat Heavy Electricals Limited
 (A Govt. of India Undertaking)
 इंडस्ट्रियल वाल्व प्लांट / Industrial Valves Plant
 गोइंदवाल साहिब / Goindwal Sahib (Tarn Taran District)

Manvir Singh
 Sr. Manager (QM)
 BHEL, IVP, Goindwal

(Signature)



भारत हेवी इलेक्ट्रिकल्स लिमिटेड
 (भारत सरकार का उपक्रम)
इंडस्ट्रियल वाल्वस प्लांट
Bharat Heavy Electricals Limited
 (A Govt. of India Undertaking)
Industrial Valves Plant

		Heat Treatment	-----	Material specification in drawing/PO	100%	Heat Treatment Report	P	V
		Visual	Free from burrs, physical damages		100%		P	P
		Marking/Identification	Material grade and supplier name or symbol	As per PO/Drawing/Applicable Standard	10%		P	W
3		Packing	Packed in wooden/cardboard box with layer to layer cushioning material.	As per PO/Drawing/Applicable Standard	10%		P	W

M-Manufacturer, V-Verification, W-Witness, P-Perform

- QAP IS PREPARED TO MEET REQUIREMENT OF ASTM 193 & ASTM 194 (Latest Revisions), PLS REFER IT, IN CASE OF AMBIGUITY ARISES.
- TPIA/BHEL MAY INCREASE SAMPLE QTY UP TO 10%.

 अमनप्रीत सिंह / Amanpreet Singh उप प्रबंधक / Dy. Manager (QM) भारत हेवी इलेक्ट्रिकल्स लिमिटेड Bharat Heavy Electricals Limited (A Govt. of India Undertaking) इंडस्ट्रियल वाल्वस प्लांट / Industrial Valves Plant गोंदवाल साहिब / Goindwal Sahib (Dist. Tarn Taran)	 Manvir Singh Sr. Manager (QM) BHEL, IVP, Goindwal	
Amanpreet Singh Dy. Manager / QM	Manvir Singh Sr Mgr/ QM & BE	S R Kenny AGM/QM & BE
Prepared	Reviewed	Approved



भारत हेवी इलेक्ट्रिकल्स लिमिटेड

(भारत सरकार का उपक्रम)

इंडस्ट्रियल वाल्वस प्लांट

Bharat Heavy Electricals Limited

(A Govt. of India Undertaking)

Industrial Valves Plant

Quality Assurance Plan for Fasteners*:

NUT, BOLT (INCL EYE BOLT, LIFTING EYE BOLT), STUD

BHE:QAP:FAS:02

Dt:15.03.2019

SN	Stage of inspection	Inspection type		Ref doc	Quantum of check	Format of Record	Agency	
							M	BHEL/TPIA
1	Raw material	Chemical/Mechanical properties		Material test certificate	100%	MTC report	V	V
2	Finished product	Chemical Analysis	Chemical composition	Material specification in drg	one sample per heat	Annex 1 of TDC	P	W
		Mechanical Properties	Tensile strength	Material specification in drg	one sample per heat	Annex 1 of TDC	P	W
			Mechanical testing for nut		10% or 20 nos hardness check at manufacturer end, one sample each type per heat for TPIA or BHEL**			
			Hardness					
		Dimension	As per drawing, Thread with GO/ NO GO Gauge	Material drg/BPS	10% or 20 nos/type.	Inspection report	P	P
		Visual	Free from burrs, physical damages		100%	Annex 1 of TDC	P	P
		MPI	ASTM E709	As per procedure	10% or 20 nos/type.	MPI report	P	W
Marking/Identification	Material grade/supplier name or symbol	As per PO/Drawing/TDC	10%	Annex 1 of TDC	P	W		

Vid
15/03/19
(MKS/WH)

S. R. Kanungo
15/03/19
(S. R. Kanungo)

S. R. Kanungo
15/03/19
S. R. Kanungo



भारत हैवी इलेक्ट्रिकल्स लिमिटेड

(भारत सरकार का उपक्रम)

इंडस्ट्रियल वाल्वस प्लांट

Bharat Heavy Electricals Limited



(A Govt. of India Undertaking)

Industrial Valves Plant

3	Rust preventive oil		As per TDC:5:164	100%	Annex 1 of TDC	P	W
	Packing	Packed in wooden/cardbo ard box with layer to layer cushioning material.		10%	Annex 1 of TDC	P	W
	Test certificate	MTC			Annex 1 of TDC	P	V

M-Manufacturer, V-Verification, W-Witness, P-Perform

- * QAP IS PREPARED TO MEET REQUIREMENT OF TDC:5:164 (latest),.PLS REFER IT, IN CASE OF AMBIGUITY ARISES.
- ** TPIA/BHEL MAY INCREASE SAMPLE QTY UP TO 10%.

 Vikas Kumar Sr. Engr / QM Prepared	 Samir Shandilya Sr Mgr/ QM &HSE Reviewed	 S R Kenny AGM/QM, HSE, Engg, TEC & SM) Approved
---	---	--

ANNEXURE-A

RESTRICTIONS UNDER RULE 144(XI) OF THE GENERAL FINANCIAL RULES (GFRs), 2017

(The bidders are required to print this on their company's letterhead & sign, stamp and submit with offer documents)

I have read the clause regarding restrictions on procurement from a bidder of a country which shares a land border with India; I certify that bidder (... Name of Bidder) is not from such a country or, if from such a country, has been registered with the Competent Authority. I hereby certify that bidder (.....Name of bidder) fulfils all requirements in this regard and is eligible to be considered.

If the bidder is from such country which shares a land border with India evidence of valid registration by the Competent Authority shall also be attached along with offer.”

With regards

Signature with company seal

Name –

Company / Organization

Designation within Company / Organization

Address of Company / Organization

 <p>087 BHEL – GOINDWAL</p>	<p style="text-align: center;">THIRD PARTY NON-DISCLOSURE AGREEMENT</p> <p style="text-align: center;">(TENDER ENQUIRY NO. 2122-087E dated 16.03.2022)</p>
---	---

ANNEXURE B: THIRD PARTY NON-DISCLOSURE AGREEMENT

I, _____, on behalf of the _____ (Name of Company), acknowledge that the information received or generated, directly or indirectly, while working with BHEL, Goindwal on contract is confidential and that the nature of the business of the BHEL, Goindwal is such that the following conditions are reasonable, and therefore:

I warrant and agree as follows:

I, or any other personnel employed or engaged by our company, agree not to disclose, directly or indirectly, any information related to the BHEL, Goindwal. Without restricting the generality of the foregoing, it is agreed that we will not disclose such information consisting but not necessarily limited to:

- Technical information: Methods, drawings, processes, formulae, compositions, systems, techniques, inventions, computer programs / data / configuration and research projects.
- Business information: Customer lists, project schedules, pricing data, estimates, financial or marketing data,

On conclusion of contract, I, or any other personnel employed or engaged by our company shall return to BHEL, Goindwal all documents and property of BHEL, Goindwal, including: drawings, blueprints, reports, manuals, computer programs/data/configuration, and all other materials and all copies thereof relating in any way to BHEL Goindwal's business, or in any way obtained by me during the course of contract. I further agree that I, or any others employed or engaged by our company shall not retain copies, notes or abstracts of the foregoing.

This obligation of confidence shall continue after the conclusion of the contract also.

I acknowledge that the aforesaid restrictions are necessary and fundamental to the business of the BHEL, Goindwal and are reasonable given the nature of the business carried on by the BHEL, Goindwal. I agree that this agreement shall be governed by and construed in accordance with the laws of country.

I enter into this agreement totally voluntarily, with full knowledge of its meaning, and without duress.

Dated at _____, this ____ day of _____, 20__.

Name

Company

Signature