

Buyers Specific Terms & Conditions (ATC)

Item Name: Steam Trap”

Project: 2x660 Mw Talcher

A. SCOPE OF ENQUIRY

E-bids on NIC are invited from bidders for the supply of Steam Trap as per requirement mentioned below:

Sl. No.	Project	Material Code & Item Description	Quantity in Nos per unit/Lot	Delivery Schedule
1	2x660Mw TALCHER CONSTRUCTION MANAGER, BHEL SITE OFFICE, 2X660 MW NTPC TALCHER, DIST- ANGUL, (ODISHA) PIN – 759107	W90313187266 STEAM TRAP WITH INTEGRAL STRINER AS PER DOCUMENT NO. 413137W1401(REV.NO.-01) AND DRG: 313137V8001 REV:00 (1ST=2NO).	1ST	04/25
			1ST	08/25
Total requirement of Steam Traps			2 SETS I.E (1SET= 2NOS)	

B. EARNEST MONEY DEPOSIT (EMD): NIL/Not applicable for this tender.

C. Buyers Specific Terms & Conditions in addition to GISTC are as below. Please confirm.

Sl. No.	Terms	Description	Your confirmation
1.	Eligibility criteria for participation in this enquiry.	This is domestic open tender enquiry and only class -1 and class-II local suppliers are eligible to participate in this tender enquiry under compliance of PPP-MII Order No. P-45021/ 2/ 2017-PP (BE-II) dtd. 04/06/2020 of Govt of India. Purchase preference to class-1 local supplier over class2 supplier shall be applicable as per PPP-MII Order No. P-45021/ 2/ 2017-PP (BE-II) dtd. 04/06/2020 of Govt of India. For MII, self-certification of local content shall be furnished by bidders in prescribed format of make in India. Please confirm	
2.	Documents Checklist:	Kindly confirm that the following documents have been submitted along with your offer: 1. Techno- commercial offer (part 1 bid) along with Pre-Qualification Requirements and supportive doc of PQR & product details /Catalogue matching BHEL requirement. 2. Signed & stamped “ <u>Buyers Specific Terms & Conditions</u> ” 3. Signed stamped copy of tender GISTC 4. Vendor Quality plan (endorsed) 5. Part-2 offer i.e price bid on GeM portal inclusive material cost, freight & Taxes etc) 6. MSE/UAM certificate (if any) 7. Self-certification of Local content under make India compliance as per Govt order (format enclosed) 8. Priced/unpriced BOQ on through NIC portal.	
3.	Pre-Qualification Requirements	The Pre-Qualification Requirements have been enclosed/uploaded with tender doc. Bidders shall be furnished the complete details and documents as per PQR requirements. The Offers submitted by the bidders would be scrutinized with respect to Pre-Qualification Requirements first. Techno-Commercial offer of only those bidders shall be evaluated who meet the Pre-Qualification Requirements.	
4.	Evaluation criteria	Evaluation shall be done on total landed cost basis (including material cost, freight, packing forwarding, taxes & duty etc.) up to BHEL Talcher project site.	
5.	Basis of Quotation	Price has been quoted “Ex-works freight prepaid basis up to Talcher Project with inclusive of the GST through NIC BOQ. ITEMS COVERD IN ENQUIRY TO BE DISPATCHED DIRECTLY TO TALCHER PROJECT SITE ADDRESSED AS BELOW. PLEASE CONFIRM. HEAD OF PROJECTS (NTPC LIMITED), TALCHER TPP, STAGE-III 2X660MW, PO TALCHER, DISTT- ANGUL STATE OF ODISHA, PIN 759101	
6.	Offer validity	Please confirm that the validity of the offer shall be valid for180 days from opening of Techno-Commercial offers/tender due date.	
7.	Reverse Auction	BHEL shall be resorting to Reverse Auction (RA) (Guidelines as available on www.bhel.com) for this tender. RA shall be conducted among all the techno-	

Sign & Stamp of bidder

		commercially qualified bidders. Price bids of all techno-commercially qualified bidders shall be opened and same shall be considered as initial bids of bidders in RA. In case any bidder(s) do(es) not participate in online Reverse Auction, their sealed envelope price bid along with applicable loading, if any, shall be considered for ranking. Please confirm. (Detailed RA policy of BHEL is available on www.bhel.com)	
8.	Delivery	Bidders are requested to offer your best possible delivery in number of weeks/ months from the date of Purchase Order or documents approval whichever is later. Please note that BHEL reserve right to reject the offer of any bidders not meeting our project delivery requirement.	
9.	Technical requirements	Please confirm to comply the following technical requirements- 1.Engg PQR 2.Engg drawing-313137V8001 3.Technical Specification 413137W1401(Rev.no. -01) ,	
10.	Engineering Document/ Document approval	Drawings/Data sheets/Documents/Type Test/ Quality Plan etc. as called for in the specifications shall be submitted for approval to BHEL for BHEL/customer approval within 07 days of purchase order. Any delay in delivery on account of late submission of drawings shall be to vendors account. BHEL will arrange the approval of the drawings/data sheets/ documents within 07 days of their receipt provided those are complete in all respect. Delays in approval shall be dealt on merit basis.	
11.	MDCC clause	Material shall be dispatched only after issue of material dispatch clearance by BHEL. All test certificates and relevant documents are to be sent to BHEL before dispatch of material for issue of MDCC, which will be issued after review of test certificates etc. MDCC will be issued within 07 days of receipt of these documents once found complete in all respects. In case of any delay on account of BHEL in issuing MDCC, delivery shall be extended by no. of days in excess of 7 days taken by BHEL in issuing MDCC and delays shall be dealt on merit basis. Material is to dispatched within 07 days of receipt of MDCC from BHEL without waiting for PO amendment.	
12.	QR code/RFID Instructions	Before shipment of material, vendor has to obtain QR code from BHEL and these QR codes (properly laminated) shall be affixed on packages/boxes/crates/bundles of material to be supplied and While packing the material following is to be ensured: Material of unit-1 and unit-2 need to be packed in separate boxes. Loose items (if any) needs to be packed in boxes/crates or bundled together. For loose items one marker board needs to be send for each bundle for fixing QR code will be issued box wise/bundle wise, vendor to ensure correct QR Code are affixed on the boxes/bundles. RFID tag will be fixed at site	
13.	O&M Manual	Two sets of O&M Manual shall be dispatched by the vendor along with the item.	
14.	Insurance	Transit insurance of materials shall be in BHEL scope. Please quote your offer accordingly.	
15.	Quality Requirements	1) VENDOR TO SUBMIT QP FOR BHEL APPROVAL. 2) INSPECTION BY BHEL NOMINATED INSPECTION AGENCY "INTERTEK" AS PER BHEL APPROVED QP. 3) SCOPE OF INSPECTION SHALL BE WITNESSING OF FUNCTIONAL TEST, HYDRAULIC TEST/LEAK TEST, PRESSURE TEST AND VERIFICATION OF DIMENSIONAL MATERIAL TC'S AND OTHER AS PER SPEC.	
16.	Guarantee/Warranty clause	Guarantee/Warranty shall be 24 months from the date of commissioning and 36 months from the date of dispatch, whichever is earlier. Supplier shall be responsible for free repair/ replacement of defective equipment /material at our site free of cost during guarantee/warranty period.	
17.	Penalty / LD Clause	In case of delay in supply of material beyond the agreed contractual delivery, Penalty for Late Delivery would be applicable @ 0.5 % of the undelivered portion per week of delay or part thereof subject to a maximum of 10% of the total order value. The date of LR (Lorry Receipt) would be treated as the date of delivery for penalty purposes.pl confirm.	

Sign & Stamp of bidder

		In case of any deviation to the above penalty clause, BHEL reserves the right to load the offers to the extent to which it is not agreed by vendors (at offered value).	
18	Payment Terms	<p>Payment terms shall be as per GISTC. Please confirm your acceptance for the payment terms of GISTC. "Receipt and Acceptance" wherever referred in payment terms clause of GISTC may be treated as "Receipt of material at site".</p> <p>Preference for MSE supplier shall be given as per policy/guidelines.</p> <p>In case of deviation in payment terms w.r.t. tender conditions, offer shall be evaluated after loading on account of deviation in payment terms as per GISTC.</p>	
19	Risk Purchase	In case of abnormal delays (beyond the maximum late delivery period as per LD clause) in supplies / defective supplies or non-fulfilment of any other terms and conditions given in Purchase Order, BHEL may cancel the Purchase Order in full or part thereof, and may also make the purchase of such material from elsewhere / alternative source at the risk and cost of the supplier. BHEL will take all reasonable steps to get the material from alternate source at optimum cost. If bidder does not agree to the above Risk Purchase Clause, BHEL reserves the right to reject the offer. In case for compelling reasons BHEL accepts the offer without acceptance of this clause by the bidder and in the eventuality of Risk Purchase, appropriate action will be taken as per BHEL extant rules. This will be without prejudice to any other right of BHEL under the contract or under General Law.	
20	Arbitration/settlement of disputes clause	In case of any dispute arising out of as in connection with this contract, the same shall be referred to arbitration under Arbitration & Conciliation Act 1996 of a sole arbitrator who shall be appointed by mutual consent of the parties. The seat & venue of arbitration shall be Haridwar. The proceedings shall be conducted in English. The Governing law of contract shall be the substitutive law of India.	
21	Action against Bidders / vendor / supplier / contractor in case of default	In order to protect the commercial interests of BHEL, BHEL shall take action against supplies / contractors by way of suspension of business dealings, who either fail to perform or are in default without any reasonable cause, cause loss of business/ money/ reputation, indulge in malpractices, cheating, bribery, fraud or any other misconduct or formation of cartels so as to influence the bidding process or influence the price etc. Suspension of Business Dealings could be in the form of "Hold" or "Banning" a supplier/ contractor or a bidder and shall be as per "Guidelines for Suspension of Business Dealings with Suppliers/ Contractors" available at BHEL's website "https://www.bhel.com/guidelinesuspensionbusiness-dealings suppliers contractors"	
22	Contact detail of bidder	<p>For necessary communication, bidders are requested to provide the follow details-</p> <p>1. Contact person & Mob number-----</p> <p>2. Official email ids (at least two or three email id) -----</p> <p>-----</p> <p>-----</p> <p>3. Works address/Location:</p>	

Sign & Stamp of bidder

PPX-BOI DEPARTMENT BHARAT HEAVY ELECTRICALS LIMITED HEEP: HARDWAR-249 403 (Uttarakhand) Email: mzp@bhel.in, manojy@bhel.in Telephone: 01334281707	Item-Steam Trap Project-2x660 Mw Talcher
---	---

Important Instruction to bidders

1. SCOPE OF ENQUIRY:

E-bids on NIC are invited from bidders for the supply of “Steam Trap” for 2x660 Mw Talcher projects detailed as below-

Project	Item description	Unit/Lot	Unit	Delivery period
2x660 Mw NTPC Talcher (Odisha)- India	W90313187266 STEAM TRAP WITH INTEGRAL STRINER AS PER DOCUMENT NO. 413137W1401(REV.NO.-01) AND DRG: 313137V8001 REV:00 (1ST=2NO).	1	1ST	04/25
		2	1ST	08/25

2. EARNEST MONEY DEPOSIT (EMD)- NIL i.e Not applicable for this tender.

3. PRE-QUALIFICATION REQUIREMENT (PQR)

The Pre-Qualification Requirements have been compiled enclosed with the tender documents. All the bidders should ensure submission of complete details and documents as called for in these requirements. The Offers submitted by the bidders would be scrutinized with respect to Pre-Qualification Requirements first. Techno- Commercial offer of only those bidders shall be evaluated who meet the Pre-Qualification Requirements.

4. SUBMISSION OF OFFER

Please note that this two part tender enquiry has been published on NIC portal (Part-I i.e. Techno-Commercial Bid along with PQR will be opened first). Subsequently, Part-2 offer i.e price bids will be open for techno-commercial qualified bidder only through NIC portal. Price shall be quoted in totality including FOR cost with GST on NIC portal.

- 4.1 Only English version or bilingual with one language as English, of all documents would be valid & binding.
- 4.2 Bidders are advised to read all the tender documents carefully. Any submission of tender by the bidder shall be deemed to have been done after careful study and examination of the tender documents and with full understanding of the implications thereof. The specifications/ Technical Requirements and terms & conditions shall be deemed to have been accepted unless otherwise specifically commented upon in ‘Deviation’ sheets by the bidder in his offer. Non-compliance with any of the requirements and instructions in the Tender Enquiry may result in rejection of the offer.
- 4.3 Name of vendor’s dealing person with Contact No(s), Email ID and Address of correspondence shall be provided in the bid.

[A] PART-I BID: PRE-QUALIFICATION REQUIREMENT (PQR) & TECHNO-COMMERCIAL BID

Following documents are an integral part of this tender enquiry and endorsed copies of these documents (duly signed and stamped on each page, as a token of acceptance) and reply for each clause of Annexure-A are to be necessarily submitted along with the ‘Techno-Commercial Bid’ (Part-I bid).

All these following documents shall be uploaded in the “Techno-commercial bid level” on NIC Portal

- Proof of EMD submission details must be uploaded on the e-procurement portal. If applicable
- Please submit duly signed & stamped copy (each page) of the Pre- Qualification Requirements (PQR) with supportive PQR documents prescribed in PQR.
- Bidders are required to furnish requisite details in the formats specified in bidding documents for meeting the stipulated Pre-Qualification Requirements (PQR) along with all supporting documents like copies of End User Certificates, Unpriced copy of Purchase Orders and Contract Agreements etc.
- Complete Technical offer with relevant drawings/ documents etc.
- Please submit duly signed & Stamped copy of replica of Price Bid (without prices) showing ‘quoted” in place of price.
- Please submit duly signed & Stamped copy (each page) of duly filled “Byers Specific ATC” and its clause wise supporting documents where required.
- Compliance of NIC-GTC (latest version) is shall be applicable.

- Please submit duly signed & stamped copy (each page) of BHEL purchase & technical specification documents enclosed.
 - Please submit Endorser copy of QAP.
 - Please submit duly signed & stamped copy (each page) of “Instructions to bidder”
 - Commercial Terms & Conditions.
- i. **Deviations if any are to be listed out separately. Please note that in case no- deviation sheet is received along with offer, it will be presumed that all terms and conditions mentioned in “INSTRUCTION TO BIDDERS, additional Terms & conditions of Tender enquiry as (Annexure-A) and “GISTC (General Instructions and Standard Terms & Conditions against Tender Enquiry)” shall be acceptable to you and your offer will be processed accordingly.**
- ii. **Any Deviation with reference to technical requirements/specification to be laid down on separate sheet along with the cost of Withdrawal of such technical deviations (if any). Acceptance of such technical deviations would be at the discretion of BHEL.**

[B] PART-II BID (PRICE-BID): Price bid

- 4.4 e-Price bid shall be quoted in totality including FOR cost with GST on NIC portal.
- 4.5 price bid shall be opened only of **Techno-Commercial qualified bidders for further evaluation and further processing as per tender conditions.**
- 4.6 All correspondence thereof, shall be addressed to the following persons:

<p>Mr. Mahavir Singh Panwar Designation: Engineer(PPX-BOI) 4th Floor, Main Administrative Building HEEP, BHEL ,Hardwar- 249403 Uttarakhand, India Email ID: <a href="mailto:m<sup>sp</sup>@bhel.in">m^{sp}@bhel.in Tel: +91 1334 1707</p>	<p>Mr. Manoj Kumar Designation: Manager (PPX-BOI) 4th Floor, Main Administrative Building HEEP, BHEL ,Hardwar- 249403 Uttarakhand, India Email ID: manojy@bhel.in Tel: +91 1334 28 5773</p>
---	---

- 4.7 BHEL prefers to deal directly with the principal manufacturers/OEM. However, if the OEM/ Principal insists on engaging the services of an agent, the same can be allowed only thru a tender specific authorization letter issued by the principal/OEM. The acceptance of any such offer would be at the discretion of BHEL.
- As per directives of CENTRAL VIGILANCE COMMISSION, GOVERNMENT OF INDIA, one agent can not represent two or more suppliers or quote on their behalf in a particular tender. If so found at any stage, BHEL Hardwar is likely to cancel Enquiries / POs to such suppliers. Further, such Indian Agent is likely to be de-listed (Black listed for business from BHEL). Moreover, either the agent could bid on behalf of the manufacturer/ supplier or the manufacturer/ supplier could bid directly but not both. In case bids are received from both the manufacturer/ supplier and the agent, bid received from the agent shall be ignored.
- 4.8 Vendors operating from BHEL quarters, unauthorized colonies on BHEL Land and Dharamshalas/ Hotels shall not be considered, hence such vendors need not apply.

5. RIGHT OF ACCEPTANCE

- 5.1 BHARAT HEAVY ELECTRICALS LIMITED HARIDWAR reserves the right to reject any or all the bids/quotations without assigning any reason thereof. BHEL also reserves the right to increase or decrease the tendered quantities. Bidders should be prepared to accept order for reduced quantity without any extra charges.
- 5.2 Any discount/ revised offer submitted by a bidder on its own shall be accepted provided it is received on or before the due date and time of offer/bid submission (Part-I) if system allow. The discount shall be applied on pro- rata basis to all items unless specified otherwise by the bidder. Conditional discounts shall not be considered for evaluation of tenders.
- 5.3 Unsolicited discounts/revised offers given after enquiry opening (i.e. Part-I bid opening) shall not be accepted.
- 5.4 In case there is no change in the technical scope and/or specifications and/or commercial terms & conditions, the bidder/s shall not be allowed to change his/their price bids after the due date (i.e. Part-I bid opening).
- 5.5 In case of changes in scope and/or technical specification and/or commercial terms & conditions, having price implications, techno-commercially acceptable bidders shall be asked by BHEL (after freezing the scope, technical specifications and commercial terms & conditions) to submit the impact of such changes on their price bid. A cut-off date and time shall be given to all the techno-commercially acceptable bidders to submit the impact on their price bids.
- 5.6 In the event of any bidder, after finalizing the technical specification & scope of supply, opting to revise and submit their latest price bid instead of submitting impact on their price bid asked by BHEL, then their latest price bid shall prevail. However in such condition their original price bid will necessarily be opened.
- 5.7 After technical & commercial examination of the offers received and clarifications obtained (if required), Part-II (Revised Price Bid/ Original Price Bid along with Price Impact and Discount, if any) shall be opened, for which the date and time shall be intimated to technically and commercially acceptable bidders in case of public opening. BHEL may opt to finalize the prices through Reverse Auction amongst technically and commercially acceptable bidders. BHEL reserves the right to open the earlier price bids, if any, submitted by the bidder(s), if required.

5.8 No correspondence shall be entertained from the tenderers after opening of Part-II (Price bid), except clarifications (if any) asked by BHEL in writing.

IMPORTANT NOTE

Kindly ensure the timely submission of your offer (by 1345 Hrs IST on the due date) and note that Late Offers shall not be entertained under any circumstances.

For and on behalf of BHEL, Hardwar

3-13137-V8001
DRAWING No.

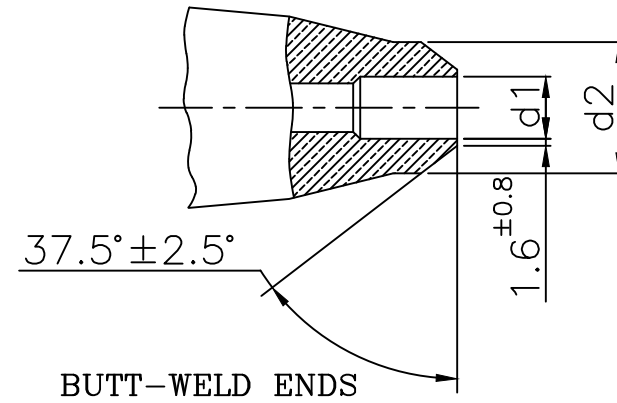
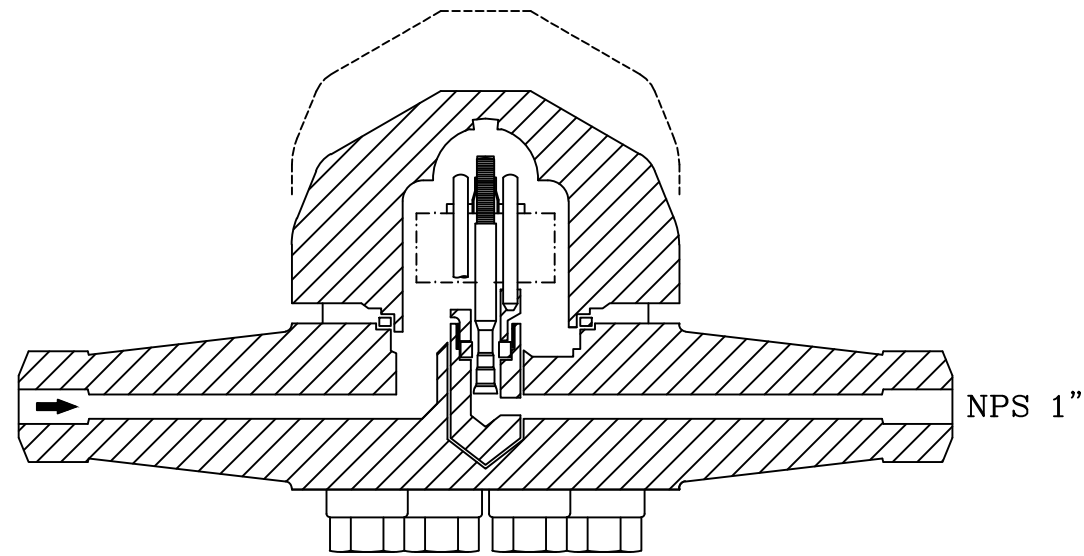

DESIGN DATA AND PIPE CONNECTION LIST FOR STEAM TRAP (THERMOSTATIC BIMETALLIC TYPE & CONSIST WITH INTEGRAL STRAINER):-

TAG NO OF STEAM TRAP	VAR 01
	MAL23AA041 MAL24AA041
MATERIAL OF STEAM TRAP	ASTM A 182 F91
MAX. INLET PR.(g)	70bar
MAX. INLET/OUTLET TEMP.	608°C
d1	24.3 mm
d2	33.4 mm
HYDROSTATIC TEST PR.(bar)	105(min.)
TYPE OF END CONNECTION	BUTT WELD

OUTLET PRESSURE IS ATMOSPHERIC PRESSURE.

NOTE:- THIS DRAWING SHALL BE READ WITH
DOC. NO. 413137W1401(Rev.No.-1).

COPYRIGHT AND CONFIDENTIAL
THE INFORMATION ON THIS DOCUMENT IS THE PROPERTY OF BHARAT HEAVY ELECTRICALS LIMITED. IT MUST NOT BE USED DIRECTLY OR INDIRECTLY IN ANY WAY DETERIMENTAL TO THE INTEREST OF THE COMPANY.

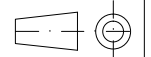
Ref. Drawing No.	GMS No./C B O M				STATUS OF DRG U	TYPE OF PRODUCT OR NAME OF CUSTOMER/PROJECT					
	Sign & Date	AGREED DEPT	NAME	SIGN		DATE	 BHARAT HEAVY ELECTRICALS LTD. RANIPUR, HARDWAR	DRN	NAME	SIGN	DATE
Inventory No.		GRADE OF UNTOL.DIM				APPD		S.K.SONKAR	-sd-	19.08.21	73
		M/CG.-C/M/F AA0230208				DEPT STE					
	WELDING-A/B/C/D AA0621104				CODE 4011	 SCALE N.T.S.	WEIGHT (KG)	REF. TO ASSY. DRG.	ITEM No.	NO. OF ITEMS	
	GAS CUTTING-'T3'AA0621101				TITLE :						
	REV DATE ALTERED CHECKED	REV DATE ALTERED CHECKED			STEAM TRAP	CARD CODE	DRAWING NO. 3-13137-V8001		REV.		
							SHEET No. 01		No. OF SHEETS 01		



**BHARAT HEAVY ELECTRICALS
LIMITED, HARIDWAR**

DOCUMENT NO.

**TL-BOI-ST-PQR-004
Rev. No.01**

TURBINE LAYOUT

Dt: 05.03.2022

**Pre-Qualification Requirement (PQR) for
STEAM TRAP**

Description

The Steam Trap is used for evacuate the trapped saturated steam (condensate) from turbine drain lines. It is thermostatic bimetallic type having integral strainer. It also has automatic air vent system. Outlet of steam trap is connected under vacuum (i.e. connected to condenser through drain header). The steam trap shall be designed for high steam flow to ensure evacuate the steam in very less time for safety of Turbine.

The above steam trap should be very reliable and proven in design. It open in sudden and allow required flow of condensate under all given conditions.

Mandatory requirement for Pre-Qualification

1.0 Experience Requirement –

1. Bidder/ its principle should have been successfully designed, manufactured, tested & supplied steam trap of thermostatic (Bimetallic plate) type to minimum one thermal power plant/process plant in the last seven(7) years (from the date of issuance of enquiry) with following technical details mentioned in table-1:-

Table-1

Sl. No.	Min Press. in (bar)	Min Temp.in (°C)	Material ASTM /equivalent or higher grade	Type of STEAM TRAP	Nominal Size
1	65	601	A182Gr.F91	Thermostatic Bimetallic Type	15 mm or higher

In support of above, Bidder to furnish information, as per the table-2 for previous supplied Steam Trap meeting the above technical requirement in last seven (7) years from the date of issuance of enquiry.

Table-2

Sl.no.	Name & address of customer	Contact Details of the customer (email & phone number etc.)	Purchase order reference no. & issued date	Type of Steam Trap	Design Pressure	Design Temperature	Nominal size	Material of Body

Bidder to submit the following documents of supplied Steam Trap for the above mentioned successfully executed order:-

THE INFORMATION ON THIS DOCUMENT IS THE PROPERTY OF BHARAT HEAVY ELECTRICALS LIMITED. IT MUST NOT BE USED DIRECTLY OR INDIRECTLY IN ANY WAY DETERIMENTAL TO THE INTEREST OF THE COMPANY.

- a) Bidder to furnish at least one copy of Un-Priced Purchase Orders executed for supply of at least one no. of Steam Trap in last seven (7) years (from the date of issuance of enquiry).
- b) Bidder to furnish the test certificate for Material, Hydraulic, leakage & functional test for Steam Trap as per relevant standard for any one of the PO submitted. The submitted test certificates should have co-relation with PO.
- c) Bidder to furnish dispatch documents w.r.to above executed P.O. i.e. approved GA drawing & data sheet of valve, delivery challan, tax invoice , inspection report & Lorry way bill for our review.

NOTE:-

1. BHEL reserves the right to verify the information submitted by bidder. BHEL may visit the factory premises of the bidder for verification and other purposes submission of false/ incorrect information shall lead to rejection of offer.
2. BHEL reserves the right to ask for more pertinent information /documents / clarifications. Bidder shall provide this information to BHEL in a timely manner so that project schedule does not hamper.

Sandhya
05/03/2022

S.K.SONKAR
(Sr. Mgr/STE-TL)

Anuj
5/3/2022

ANUJ JAIN
(SDGM/STE-TL)

Anil Kumar
5/3/2022

ANIL KUMAR
(Sr. Engr./STE-TL)

Table of content

page

1	Scope of Application	2
2	Type-tested Valves	2
3	Referenced Documents	2
4	Technical Data and Design.....	2
5	Inspection certificate / Declaration of Compliance in Dependence on Fluid, Pressure and Temperature	2
6	QA-Requirements regarding the Valve Manufacturer and his Suppliers	2
7	Manufacturing and Inspection Plan (MIP)	3
8	Condition for Manufacturing.....	3
9	Fabrication and Inspection.....	3
9.1	Steel Castings	3
9.2	Rolled or Forged Material.....	3
9.3	Connecting Elements	3
9.4	Welding.....	3
9.5	Manufacturing Inspections	4
10	Marking	4
11	Surface Protection	4
12	Documentation.....	5
13	Final inspection.....	5
14	Delivery and Packing.....	5
15	Guarantee.....	6
16	Spares	6
17	Special Tools & Tackles	6
18	Supplementary Requirements.....	6
19	Deviations	6

Continued page 2 to 6

1 Scope of Application

This Technical Purchasing Specification covers requirements regarding steam trap. This steam trap is used to withstand water hammer. Steam trap discharge the condensate to condenser with virtually no banking up & also without loss of steam.

2 Type-tested Valves

Valves with a valid type-testing certificate according to PED97/23/EC and to the corresponding VdTÜV-Merkblätter, of TRD 110 attachment 1 as well as accordingly to the registration of DIN-DVGW fulfill the requirements of this specification.

For these valves the requirements for manufacturing and testing agreed upon with the TÜVs respectively with the DVGW-federation shall be fulfilled (declaration of commitment).

3 Referenced Documents

- AD2000-W 0
- AD2000-W 7
- AD2000-HP 0
- AD2000-HP 5/3
- TRD 100
- EN 287-1
- DIN EN ISO 15607
- DIN EN ISO 15609-1
- DIN EN ISO 15614-1
- EN 1418
- EN 10028
- EN 10204
- EN 10213
- EN 10222
- EN 10273
- DIN 1690-10
- EN 1559-1
- EN 1559-2
- EN 12266-1/-2
- DIN 17175,
- PED 97/23/EC
- ASME B16.34

In case of differences or contradictions of the referenced documents the higher requirements shall be applied.

4 Technical Data and Design

The criteria, e.g. fluid, pressure, temperature, material of the casing, etc., as well as other technical data are given in the enquiry.

Also, steam trap shall consist integral strainer.

5 Inspection certificate / Declaration of Compliance in Dependence on Fluid, Pressure and Temperature

an Inspection Certification 3.1 according to EN 10204 must be provided for steam trap.

6 QA-Requirements regarding the Valve Manufacturer and his Suppliers:

The valve manufacturer as well as his suppliers for the main components like e.g. pressure guiding components, instrumentation and control, shall have an introduced and well-working quality management system, e.g. according to EN ISO 9000 series or equivalent standard. Manufacturers of pressure guiding components shall have in addition a certificate according to AD2000-W 0 respectively TRD 100.

As far as welding will be performed on the valves, the weld shop shall be certified according to AD2000-HP 0.

7 Manufacturing and Inspection Plan (MIP)

The valve manufacturer shall prepare a Manufacturing and Inspection Plan containing sufficient information on the sequence and extent of the valve inspections as well as the main raw material and shall deliver this to the purchaser for review at the latest 4 weeks after order receipt, but at least 2 weeks before starting manufacturing.

8 Condition for Manufacturing

Manufacturing of the valve mentioned in point 7 shall not be started before the review for the design as well as for the MIP has been given by the purchaser. To prohibit any delay the valve manufacturer shall call for missing reviews and remind the purchaser on time.

By reviewing the MIP the purchaser does not take on any responsibility for processes or manufacturing details of the valve manufacturer or his suppliers, or for the valve itself.

9 Fabrication and Inspection

9.1 Steel Castings

Steel castings, e.g. valve casings, covers, etc., shall be manufactured and inspected according to EN 10213 and EN 1559 part 1 and part 2 and DIN 1690 part 10, and following minimum requirements:

- Analysis (chemical composition) per heat
- Mechanical properties per heat and heat treatment batch, for castings with an individual weight > 1000 kg testing per casting
- Amount of non-destructive testing according to DIN 1690 part 10:
 - weld ends of valves without connection pieces: Quality class A with quality grades S1 + V1
 - transition areas: quality class B with quality grades S2 + V2
 - weld ends of valves with connection pieces: Quality class B with quality grades S2 + V2
- remaining areas of the casting: quality class D with quality grades S3 + V4; additionally for castings ≥ 500 kg or DN ≥ 400 mm each casting 100% volume inspection shall be performed.

9.2 Rolled or Forged Material

Rolled or forged material, e.g. connection piece, shall be manufactured and inspected according to the corresponding material standard, e.g. EN 10028, EN 10088, EN 10222, EN 10273, DIN EN 10216-2 and DIN 17440, etc. and following supplements:

- Analysis (chemical composition) per heat
- Mechanical properties per heat and heat treatment batch

9.3 Connecting Elements:

Connecting elements shall be manufactured and tested according to AD2000-W 7. As far as there is a requirement for a test certificate for grade properties, this shall be an inspection certificate 3.1 according to EN 10204.

9.4 Welding

As far as welding will be performed on the valves (also in case of fabrication welding on castings):

- Welding shall be performed only by welders tested in line with EN 287 or mechanized welds by welding operators tested in line with EN 1418
- Corresponding welding procedure specifications and procedure approval records according to
 - DIN EN ISO 15607
 - DIN EN ISO 15609-1
 - DIN EN ISO 15614-1 shall be available.
- Fabrication welds on castings shall be inspected according to DIN 1690.
- Fabrication welds having a length ≥ 150 mm or a depth $\geq 40\%$ of the wall thickness or a depth ≥ 25 mm shall be recorded.
- Design welds shall be inspected according to AD2000-HP 5/3. In case of serial production manufacturer-specific inspection concepts may be applied with written agreement of the purchaser.
- If cast steel parts are subjected to heat treatment in the course of valve manufacture, all parts

heated shall subsequently be subjected to a 100% surface crack examination.

9.5 Manufacturing Inspections

Manufacturing inspections shall be performed according to PED 97/23/EC / EN 12266. The PED 97/23/EC as a superior legislation shall be observed and applied. These are especially:

- a) Pressure test
 - Test P10 according to EN 12266 part 1
- b) Leak test
 - Test P11 + P12, leakage class B according to EN 12266 part 1
- c) Functional test
 - Test F20 according to EN12266 part 2
- d) Verification of dimensions
 - Main dimensions
 - connecting dimensions

All tolerance ranges which are important for the function shall be recorded. as

 - Stem diameter
 - Diameters of guides and fits

10 Marking

Valves shall be marked as follows:

- The name and address or other means of identification of the manufacturer and, where appropriate, of his authorized representative established within the Community
- Nominal diameter
- Nominal pressure class
- Casing material
- Flow direction arrow
- Identification-no. (also commission-no.)
- The year of manufacture
- Identification of the pressure equipment according to its nature, such as type, series or batch identification and serial number
- Essential maximum/minimum allowable limits

is applicable for European Union countries.

Valves with a total weight > 1000 kg shall be marked additionally with a permanent information of the weight on the valve or on an safe name- plate.

The provisional KKS-Labels which are fabricated and properly sized are to be made of plastic or similar unbreakable material and attached to the component by wire. The lettering on the labels should include the KKS classification in back, permanent ink.

Marking of the materials for all pressure loaded casing components shall survive during all manufacturing processes according to AD2000-HP 0.

11 Surface Protection

Surface coating of non-stainless steel valves shall be applied as follows

<u>Paint (Coat)</u>	<u>Paint Type</u>	<u>No. of coat</u>	<u>DFT*</u>
Primer Paint	: Epoxy base Zinc rich primer paint	1 Coat	35
Intermediate Paint	: Epoxy TiO2 Pigmented Polyamide Cured Paint	1 Coat	70
Finish (Final) Paint	: Aliphatic Acrylic 2 Pack Polyurethane Finish paint	2 Coats	75

*DFT – Dry Film Thickness (final) in microns

- Shade as per RAL – Grey 9002

12 Documentation

All the documentation for the delivered valve shall remain with the valve manufacturer and shall be stored

for at least 10 years. This documentation shall be labelled such as to ensure traceability and allocation to the corresponding valve and shall be marked as belonging to BHEL. The valve manufacturer shall check the documentation with respect to completeness and correctness before shipping the valve. The valve manufacturer shall certify this at the time of the delivery. It is the obligation of the valve manufacturer to hand over a copy of the total documentation to the purchaser on request and free-of-charge.

BHEL expects a documentation of the module/parts including all instructions which are necessary for service, installation and maintenance. Amendments will be requested separately.

In accordance to the Machinery Directive (98/37/EC) and Pressure Equipment Directive (97/23/EC) the following records and logs shall be provided to the purchaser in any case:

- manufactures declaration
- Declaration of conformity
- Material certificates
- Pressure test
- Non-destructive tests

The documentation - also that of the sub suppliers - shall be written in English language and shall contain at least:

- Test certificates of the prematerial (at least inspection certificate 3.1B according to EN 10204)
- Records of all inspections performed by the valve manufacturer or his sub suppliers during manufacturing:
 - Non-destructive inspections of e.g. weld areas or welds
 - Verification of dimensions
 - Pressure and leak tests
 - Functional tests
- Heat treatments performed
- The European Union guidelines and standards which are valid and can be used for the area of application (e.g. PED 97/23/EG, Low-Voltage Guideline 73/23/EEG, etc..) are to be designated in the declaration of conformity according to the remarks and applied quality modules, and shall include all relevant data (see e.g. appendix VII of Guideline 97/23/EG). Risk disclosure and danger analyses in accordance with EN 1050 are to be handed over to BHEL if necessary.
- If materials without European material approval are drawn on for the order (order papers/designs) (e.g. ANSI/ASME materials) appropriate substitute certificates from a designated authority shall be procured and documented accordingly. If the order pertains to a component of a total design group, then all certificates and certification of the component of the highest category of the total design group shall be made available.

13 Final inspection

The purchaser reserves the right to perform final inspections on his ordered parts in the shop of the valve manufacturer, as well as in the shop of his sub suppliers

14 Delivery and Packing

Details regarding delivery are given in the order, however at least following details shall be given together with the delivered parts:

Actualization of standards and instructions

- Purchaser
- Order-no. / project
- Manufacturer commission-no. / works-no.
- Specification
- Number of pieces
- Type / item
- Nominal diameter [DN]
- Maximum allowable pressure [PS]
- Maximum allowable temperature [TS]
- Fluid
- Manufacturer drawing-no.
- Identification-no. of the valve
- Piece weight

Together with the delivery of the valve the valve manufacturer shall hand over a certificate 2.1 according to EN 10204 in English, which confirms that the delivered valve fulfills the requirements given in the order and in this specification. Furthermore the valve manufacturer shall confirm that only materials as listed in the design bill of material have been used and that the documentation is available in his shop in line with Item 12 above and that he has checked the documentation carefully.

Packing of the valve shall be as follows:

- The valve shall be packed and locked that way, that in general case any damage will be prohibited.
- All openings shall be plugged.
- Detail parts respectively components shall be packed individually, however assignment shall be ensured.
- As far as necessary accessory devices for transportation purposes shall be attached to the valve and/or to the packing, e.g. lifting eyes and lifting signs.
- Bearing areas shall be marked, if necessary.

15 Guarantee

The supplier shall guarantee trouble free operation of the equipment for a period of 2 years after installation and commissioning or a period of 3 years from the date of dispatch of equipment whichever is earlier.

If during erection/commissioning and operation at site, any defect in any component is detected, purchaser's / owner's site representative shall prepare the assessment report and a copy of the same shall be forwarded to the supplier. The supplier shall replace / rectify the concerned items free of charge. The supplier, if he so desires, may depute his representative to site at his own cost otherwise the report of purchaser's / owner's site representative shall be binding on the supplier.

16 Spares

The offer of valves shall include the requirement of spares to be made available at the time of erection & commissioning. A separate offer of spares to be required for 3 to 5 years of operation shall also be separately enclosed along with main offer.

17 Special tools & tackles

Any special tools & tackles, required for erection, commissioning and maintenance of valves shall be included in main offer per set of valves.

18 Supplementary Requirements

The valve manufacturer shall send following documents in triplicate written in English language to the purchaser's department for records. Documents listed under a) and c) shall be delivered with the order acknowledgement:

- a) Part drawing showing the function of the valve and the design bill of material
- b) Operating and maintenance instruction
- c) Spare part list

19 Deviations

Equivalent ASME B16.34 requirements may be considered in place of given in PED 97/23/EC / EN 12266 or International standards.
Any deviation is accepted only if this has been approved or accepted by the purchaser in writing.
In case of any deviation from the specified properties, also if the proof by testing is not required, the purchaser has the right to reject the material.



BHARAT HEAVY ELECTRICALS LIMITED

HEEP-HARIDWAR, UTTARAKHAND (249403)

General Instructions and Standard Terms & Conditions for bidding against Tender Enquiry (GISTC)

For Indian Bidders (Version June-2021, Rev: 06)

Table of Contents

1. GENERAL	1
2. ORIGIN OF QUOTATION	1
3. SUBMISSION OF TENDER	1
4. TENDER OPENING	2
5. SPECIFICATION, DRAWINGS & STANDARD	2
6. PRICE SCHEDULE	3
7. REVERSE AUCTION	3
8. DELIVERY TERMS	3
9. PENALTY FOR LATE DELIVERY	4
10. PAYMENT TERMS	4
11. TAXES & DUTIES	5
12. BANK GUARANTEE	6
13. GUARANTEE / WARRANTY AND CORRESPONDING REPAIRS / REPLACEMENT OF GOODS	6
14. QUALITY REQUIREMENT	6
15. VALIDITY	6
16. RIGHT OF ACCEPTANCE	6
17. TRANSIT INSURANCE	7
18. RISK PURCHASE	7
19. FORCE MAJEURE CLAUSE	7
20. NON-DISCLOSURE AGREEMENT	8
21. SETTLEMENT OF DISPUTES / ARBITRATION	8
22. WHARFAGE / DEMURRAGE RESPONSIBILITY	8
23. CONDITIONS FOR AVAILING MICRO & SMALL ENTERPRISES (MSE'S) BENEFITS	8
24. INFORMATION TO THE BIDDERS	10
25. MAKE IN INDIA (GOVT-NOTIFICATION)	10
26. RESTRICTIONS UNDER RULE 144(XI) OF THE GENERAL FINANCIAL RULES (GFRs), 2017	12

27. NOTE..... 12

1. GENERAL.

These general terms & conditions shall apply to all the Tender Enquiries, notice inviting tenders, request for quotations concerning the supply of goods and / or rendering of services to Bharat Heavy Electricals Ltd., HEEP, Haridwar (hereinafter referred to as BHEL or the Purchaser). In case of placement of order these conditions will become part of Purchase Order (P.O) until unless the deviations are specifically agreed by BHEL.

2. ORIGIN OF QUOTATION.

- a) The quotation should preferably be from the principal bidder. However tender specific authorized registered dealer/agent can also submit the bid on their behalf, failing which the quotation is liable to be ignored. BHEL prefers to deal directly with the principal manufacturers.
- b) An agent cannot quote on behalf of more than one principal in the same Tender Enquiry.

3. SUBMISSION OF TENDER.

- a) Bid / Quotation must be enclosed in sealed cover on which tender enquiry number and the due date MUST BE written and be invariably sent under REGISTERED POST / SPEED POST / COURIER / Dropped in the Tender Box: addressed as follows:

Quotation against Enquiry No. _____

Dated: _____

Due on: _____

To,

**THE HEAD OF MATERIALS MANAGEMENT,
Heavy Electrical Equipment Plant,
Bharat Heavy Electricals Limited,
HARIDWAR-249403 (Uttarakhand), INDIA.**

- b) TENDER ROOM is located at: Room No. - 415, 4th Floor, Main Admin. Building, BHEL-HEEP, Haridwar.

Quotations / Bids not in accordance with General Instructions and Standard Terms & Conditions are likely to be ignored.



BHARAT HEAVY ELECTRICALS LIMITED

HEEP-HARIDWAR, UTTARAKHAND (249403)

General Instructions and Standard Terms & Conditions for bidding against Tender Enquiry (GISTC)

For Indian Bidders (Version June-2021, Rev: 06)

- c) In case of Three / Two Part Bid, technical bid containing technical offer, duly signed and un-priced copy of the Price Bid should be kept in one envelope. Price Bid containing only the price should be kept in a separate envelope. All envelopes indicating Part-1 or Part-2 or Part-3 as the case may be to be put in a bigger envelope. Please note that un-priced bid should be the exact replica of price bid but without prices.
- d) The bid / quotation must be posted before due date, keeping allowance for postal transit time. Quotations sent by any mode but not received in time will be ignored. Tender received through authorized E-mail is also acceptable. However, in time submission of tender in tender box shall be the responsibility of the bidder, sent through any mode. Documents submitted with the offer / bid shall be signed and stamped in each page by authorized representative of the bidder.
- e) Any additional documents submitted by supplier / bidder, during processing of registration application / tender or after placement of order shall not be accepted unless it is submitted with forwarding letter and duly signed and stamped.
- f) The bids of the bidders who are on the banned list and also the bids of the bidders, who engage the services of the banned firms, shall be rejected. The cutting / overwriting in the bid / offer must be duly attested by the signatories to the bid. The list of firms banned by BHEL is available on BHEL web site www.bhel.com.
- g) Being PMD vendor, if you are not quoting against this tender enquiry, please send your regret letter positively for our reference with valid reasons for not participating in the tender enquiry. Repeated lack of response on the part of bidder may lead to deletion such PMD vendor from BHEL's approved vendor list.
- h) The bidders will submit Integrity Pact, duly signed by its authorized signatory, along with their bids wherever estimated tender value is Rs. 2 Crore or more.
- i) In case of open tender, technically qualified unregistered bidders may apply online for registration through <http://www.bhel.com/index.php/vender>.
- j) BHEL reserves the right to award tendered quantities among more than one bidder (after acceptance of L1 price by the other bidders). BHEL can also consider awarding of part of the tendered quantity to other than L-1 bidder at L1 counter offered rates, if the quantity offered by the L-1 bidder is less than the quantity tendered for.
- k) In case of e-Tendering (Online bidding through e-portal), offline bid submitted in hard copy or in any other form by the vendor / supplier will not be accepted and will be rejected out rightly. Only e-portal bid will be accepted.

4. TENDER OPENING.

Tender opening is scheduled to start in the Tender Room at 2:00 PM, on the due date. Therefore, bid / quotations must reach this office / tender Box latest by 1:45 PM on due date. Only participating bidders are allowed to attend tender opening. **TENDERS RECEIVED AFTER THE SPECIFIED TIME OF THEIR 'SUBMISSION' WILL BE TREATED AS LATE TENDERS AND SHALL NOT BE CONSIDERED UNDER ANY CIRCUMSTANCES.** The bidders or their authorized representatives may be allowed to attend tender opening if duly authorized by their principals, through a tender specific letter on that particular day. General authorization letter is not acceptable.

Note: - Foreign bidders willing to attend the bid opening has to provide the requisite documents to the concerned Purchase executives for arranging gate pass for them.

5. SPECIFICATION, DRAWINGS & STANDARD.

- a) Bidders must give their detailed specification in the quotation along with relevant technical literature / catalogue etc. against the tender enquiry.
- b) The Bid should be accompanied with relevant copies of catalogues, drawings or specification as per tender enquiry.

Quotations / Bids not in accordance with General Instructions and Standard Terms & Conditions are likely to be ignored.



BHARAT HEAVY ELECTRICALS LIMITED

HEEP-HARIDWAR, UTTARAKHAND (249403)

General Instructions and Standard Terms & Conditions for bidding against Tender Enquiry (GISTC)

For Indian Bidders (Version June-2021, Rev: 06)

If these documents are not furnished, the offer is liable to be rejected.

- c) Wherever national / international (N/IN) standards are referred, the latest N/IN standards are to be followed. Mention year & date of standard revision that shall be followed for the supply.
- d) All Drawings and Standards are proprietary of BHEL. It must not be used in anyway detrimental to the interest of the company or without permission of BHEL.

6. PRICE SCHEDULE.

- a) Kindly quote your prices in figures and words both. In case of any discrepancy in value, the prices quoted in words shall be considered for evaluation and establishing L1 status.
- b) Prices quoted should not be more than the prices quoted to any other BHEL units / offices / divisions. Vendor to submit copy of latest Purchase Order placed by any unit of BHEL for similar items in the technical bid. In case no order has been placed on such items, specific confirmation that no order has been placed on such items should be provided.
- c) Prices should be quoted on F.O.R. Destination basis. Transit insurance shall be arranged by BHEL and not to be included in the prices. The offers quoted on other than F.O.R destination basis may result in non-consideration of such bids.
- d) In case BHEL accepts the EX-Works prices, such offers will be loaded by 1.5% of EX-Works value towards freight or with actual freight charges as per BHEL freight rate contract whichever is higher.
- e) In case of Indigenous items covered by DGS & D Rate Contract, the bidders should submit latest valid copy of the rate contract along with bid / quotation
- f) Applicable **IGST / CGST / SGST** and any other statutory levy should be indicated separately and clearly in the bid / quotation.

- g) Bidders can dispatch goods through any Indian Bank Association approved transporters having their branch at HARIDWAR / destination. If material is dispatched through other than Indian Bank Association approved transporter, material to be delivered on door delivery BHEL Stores basis.
- h) In case of dispatch of material through any other unapproved transporter, payment shall be made only after receipt of material and any additional charges payable to the transporter shall be to the bidder's account.
- i) Any demurrage / godown rent payable to the transporter / or to godown's owner due to any delay attributed by the supplier shall be recovered from supplier's account.
- j) Currency of Evaluation shall be INR.

NB: Financial evaluation of L1, L2Status will be on the basis of Landed Cost to BHEL.

7. REVERSE AUCTION.

Wherever RA is declared in the special terms and conditions of tender enquiry, following shall be applicable and Bidders to confirm the same:

"BHEL shall be resorting to Reverse Auction (RA) (Guidelines as available on www.bhel.com) for this tender. RA shall be conducted among all the techno-commercially qualified bidders.

Price bids of all techno-commercially qualified bidders shall be opened and same shall be considered as initial bids of bidders in RA. In case any bidder(s) do(es) not participate in online Reverse Auction, their sealed envelope price bid along with applicable loading, if any, shall be considered for ranking."

8. DELIVERY TERMS.

- a) Goods shall be delivered on 'FOR Destination' basis to the named destination unless otherwise called for in the tender enquiry.
- b) Loading on account of 3rd party inspection charges in case of Indian bidders shall be 0.20%.

Quotations / Bids not in accordance with General Instructions and Standard Terms & Conditions are likely to be ignored.



BHARAT HEAVY ELECTRICALS LIMITED

HEEP-HARIDWAR, UTTARAKHAND (249403)

General Instructions and Standard Terms & Conditions for bidding against Tender Enquiry (GISTC)

For Indian Bidders (Version June-2021, Rev: 06)

9. LIQUIDATED DAMAGES (LD) FOR LATE DELIVERY.

a) Where items of Purchase Order are independently usable.

Liquidated Damages (LD) for Late Deliveries shall be applicable @0.5% per week or part thereof on the value of respective delayed supplies subject to a maximum of 10% of the value of respective delayed supplies. Value of delayed supplies will mean the Gross Value payable to the vendor (Before LD) against such supplies excluding taxes and duties.

b) Where the total items are required for a main equipment and items are interdependent.

Liquidated Damages (LD) for Late Deliveries shall be applicable @0.5% per week or part thereof on total value of Purchase Order subject to maximum of 10% of the total value of Purchase Order. Purchase Order value for this purpose shall be the Total Gross Value payable to the vendor (Before LD) excluding taxes and duties.

c) Bidders are requested to quote the best delivery meeting the delivery requirements. BHEL reserves the right to reject the offers not meeting BHEL's delivery requirement.

d) Commencement of delivery period shall be reckoned from the date of PO / LOI or any other agreed milestone.

e) Bidder shall deliver the goods in the manner and schedule agreed under the terms and conditions of Purchase order.

f) **DELIVERY IN CASE OF REJECTION:** In case the material is rejected, then date of replacement will be considered as the actual date of delivery.

g) **DELIVERY AGAINST BANK DOCUMENTS:** In case payment terms quoted by bidder are documents through bank, and the delivery terms being "FOR Haridwar / FOR Transporter Go-down" then date of delivery will be date of intimation by transporter / bidder of delivery of material at Haridwar for the LD purpose.

h) Where the payments are through bank, the documents may be presented for negotiation to BHEL authorized / nominated bank.

10. PAYMENT TERMS.

a) BHEL's standard payment term is Payment after receipt and acceptance of materials / items at HEEP, BHEL-Store or at desired destination unless otherwise specified in Special Terms attached to the tender enquiry.

b) BHEL reserves the right to accept or reject the offer of the bidder who quotes the payment term other than BHEL's standard payment term.

c) Loading on account of deviation in payment terms shall be done as per extant rules of BHEL-Haridwar.

d) 100% payment along with taxes, freight & insurance will be made after receipt and acceptance of material and within 75 days from the date of invoice subject to submission of non-discrepant documents within 15 days of supply as per terms and conditions of Purchase Order. In case any discrepancy found in the documents, BHEL will notify the same to vendor within 7 days of receipt. Vendor has to clear all the discrepancies in one go within 7 days thereafter else the payment of vendor may get delayed.

e) For MSEs (covered under MSME Act) which are registered and periodically renewed with BHEL, the payment will be made within 45 days or as prescribed in the relevant act.

f) Adherence to the above time schedule of payment is contingent upon Vendor complying with GST Rules w.r.t availment of Input Tax Credit by BHEL.

g) In case GST credit is delayed / denied to BHEL, due to non / delayed receipt of goods and / or tax invoice or expiry of the timeline prescribed in GST Law for availing such ITC, or any other reason not attributable to BHEL, GST amount shall be recoverable from Vendor along with interest levied / leviable on BHEL.

h) The taxes and duties that are reimbursed would be the ones applicable as on the contractual Purchase order delivery date or the amount actually paid whichever is less.

i) **The loading criteria for the different payment terms shall be as under;**

Payment Terms	Days of
---------------	---------

Quotations / Bids not in accordance with General Instructions and Standard Terms & Conditions are likely to be ignored.



BHARAT HEAVY ELECTRICALS LIMITED

HEEP-HARIDWAR, UTTARAKHAND (249403)

General Instructions and Standard Terms & Conditions for bidding against Tender Enquiry (GISTC)

For Indian Bidders (Version June-2021, Rev: 06)

	Loading
After Receipt & Acceptance of material within 75 days of supply.	No Loading
Against Delivery at BHEL-Stores Haridwar.	45
Against documents through bank (CAD):	45
Letter of Credit (LC)	120
Usance LC	No Loading if usance period is > 120 Days.
	Loading of days' difference i.e. difference between 120 days and usance period if the usance period is < 75 days.
Advance	Delivery Period + 120 Days - Advance Payment Days.

j) Payment of Liquidated Damages (LD) shall not in any way relieve the vendor from any of its obligations & liabilities under the contract.

11. TAXES & DUTIES.

- The bidder to specify in their offer (part 1 bid) the category of their registration under GST like Registered, Unregistered and composite dealer.
- The provisional GST registration number of Bharat Heavy Electrical Ltd, Heavy Electricals Equipment Plant, Ranipur, Haridwar is "05AAACB4146P1ZL" with state Code as "05" and State Name as "Uttarakhand".
- Please quote our provisional GST registration number in all invoices raised for supply of goods and services under GST regime and also ensure filing of timely return and payment of tax and compliance of other applicable provisions on supplier under GST regime.
- No GST will be reimbursed to unregistered or composite dealer. In the event, any GST is quoted by composite dealer, the same shall be added to the cost of supply in evaluating the bid.
- Since, input credit of GST will be available to BHEL-Haridwar only after correct filing of return and payment of applicable GST by supplier, reimbursement of GST shall be made by BHEL-Haridwar on matching of vendor inputs at GST portal,

ensuring availability of input credit to BHEL Haridwar. Payment of GST will be made to vendor after matching of input credit and vendor to ensure submission of their invoices along with consent to accept payment of tax after such matching in all cases where bills are submitted directly to BHEL-Haridwar or through bank or under LC or through any other mode.

- In the event of any disallowance of input credit or applicability of interest or any other financial liability arises on BHEL-Haridwar due to any default of supplier under GST, such implication shall be to supplier's account.
- In the event of any change in the status of the vendor after the submission of the bid but before the supply, GST applicable at the time of supply or in the bid, based on the registration status of the vendor, whichever is lower shall be payable.
- Where ever applicable If PAN (Permanent Account Number) of the recipient is not available, income tax is deductible either at the normal rate or at the rate of 20 percent, whichever is higher as per Section 206AA of Indian Income Tax Act 1961.
- The bidder shall clearly indicate HSN (*Harmonised System Nomenclature*) / SAC (*Service Accounting Code*), its description and applicable rate of GST for each item in his techno-commercial bid.
- Statutory Variation in Taxes & duties as applicable at the time of supply shall be payable. However, in the event of no change in law but bidder quoting certain tax structure in bid document which is lower than the applicable one, such amount shall be the maximum amount of tax that can be claimed by bidder.
- IMPORTED GOODS OFFERED BY INDIAN BIDDERS AGAINST DEALER INVOICE:** Wherever the material being offered is imported, the bidder must quote the prices inclusive of IGST. The rate and value of IGST as included in the price must be indicated separately. In case quantum of IGST is not mentioned by the bidder the same will not be considered for evaluation. However, bidder will have to pass on the benefit of IGST to BHEL at the time supply.

Quotations / Bids not in accordance with General Instructions and Standard Terms & Conditions are likely to be ignored.



BHARAT HEAVY ELECTRICALS LIMITED

HEEP-HARIDWAR, UTTARAKHAND (249403)

General Instructions and Standard Terms & Conditions for bidding against Tender Enquiry (GISTIC)

For Indian Bidders (Version June-2021, Rev: 06)

- l) In case of directly dispatchable items to Customer's Site, BHEL-Haridwar will inform the GST registration number of the respective customer which must be mentioned on the vendor's invoice. Vendor to ensure availability of such information from BHEL-Haridwar before dispatch of any material. However, while filing GSTN-1, BHEL Haridwar GSTN number to be quoted.

Note: - Vendors must ensure compliance of all the applicable rules and procedure as envisaged in the GST Regime. Any loss to BHEL-Haridwar due to fault / non-compliance by the vendor will be to the vendor's account.

12. BANK GUARANTEE.

In case the bank guarantees are required to be deposited towards security deposit/performance guarantee or for any other purpose as per the terms of this tender enquiry, such bank guarantees of the requisite value in the denominated currency of the purchase order should be from one of the Indian branch of BHEL consortium banks and the bank guarantee should be in the proforma as prescribed by BHEL. The proforma of bank guarantee and the list of consortium banks are displayed at BHEL website www.bhelhwr.co.in. However, in case the bank guarantee is not from BHEL consortium banks, then the bidder has to get the bank guarantee confirmed from one of the Indian branch of BHEL consortium banks and the bank charges for such confirmation will be borne by the bidder.

13. GUARANTEE / WARRANTY AND CORRESPONDING REPAIRS / REPLACEMENT OF GOODS.

Goods shall comply with the specifications for material, workmanship and performance. Unless otherwise specified, the warranty shall be for a period of 18 months from the date of receipt. If the delivery is found non-compliant during the warranty period, leading to rejection, the Seller shall arrange free replacement / repair of goods, within one month from the date of intimation or any mutually agreed period. The rejected goods shall be taken away by the Seller at his cost and replaced on Delivered Duty Paid (DDP) (FOR - BHEL Stores / designated destination basis) within such period. In the event

of the Seller's failure to comply, Purchaser may take action as appropriate, including Repair / Replenish rejected goods & disposal of rejections, at the risk & cost of the Seller. In case the defects attributable to Seller are detected during processing of the goods at BHEL or at our subcontractor's works, the Seller shall be responsible for free replacement / repair of the goods as required by BHEL.

- b) **RETURN OF REJECTED MATERIAL FOR REPLACEMENT:** The bidder shall have to pay 5% incidental charges while taking back supplied material if it is found rejected on receipt. The rejected material shall be sent back only after receipt of replacement / submission of BG / refund of amount paid.

14. QUALITY REQUIREMENT.

Your bid / quotation should have specific confirmation regarding meeting all our quality requirements such as. (i) Test Certificate (TC), (ii) Guarantee Certificate (GC) / Warranty Certificate (WC), (iii) Quality Plan (QP) (if applicable); and (iv) Pre-Dispatch Inspection at your works (if applicable).

15. VALIDITY.

The quotation should be valid for a minimum period of 90 days effective from the date of opening of tender, unless otherwise specified in the tender enquiry.

16. RIGHT OF ACCEPTANCE.

- a) **BHARAT HEAVY ELECTRICALS LIMITED HARIDWAR** reserves the right to reject any or all the bids / quotations without assigning any reason thereof. BHEL also reserves the right to increase or decrease the tendered quantities. Bidders should be prepared to accept order for reduced quantity without any extra charges.
- b) Any discount / revised offer / bids submitted by a bidder on its own shall be considered, provided it is received on or before the due date and time of offer / bid submission (Part-1). Conditional discounts shall not be considered for evaluation of tenders.
- c) Unsolicited discounts / revised offers / bids given after Part-1 bid opening shall not be accepted. No change in price will be



BHARAT HEAVY ELECTRICALS LIMITED

HEEP-HARIDWAR, UTTARAKHAND (249403)

General Instructions and Standard Terms & Conditions for bidding against Tender Enquiry (GISTC)

For Indian Bidders (Version June-2021, Rev: 06)

permitted within the validity period asked for in the tender enquiry.

- d) In case of changes in scope and / or technical specification and / or commercial terms & conditions having price implication, techno-commercially acceptable bidders shall be asked by BHEL to submit the impact of such changes on their price bids. In case a bidder opts to submit revised price bid instead of impact called for then the latest price bid shall prevail. However, in both situations, original price bid will be necessarily opened.
- e) The bidder whose bid is technically not accepted will be informed & EMD wherever submitted shall be returned after finalization of contract. EMD shall be forfeited in the event of bidder opting out after tender opening.
- f) BHEL reserves the right to short close the existing Purchase Order / Rate Contract / Work Order or any extension thereof at any stage.

17. TRANSIT INSURANCE.

- a) Transit Insurance will be covered by BHEL under its open Insurance Policy. Seller shall inform dispatch particulars (Purchase Order, RR /GR, Invoice value etc.) to "Finance department (Store bill Section), BHEL Ranipur, Haridwar (Uttarakhand-India) with value of consignment to the Purchaser within 07 days of dispatch for BHEL to arrange insurance coverage in its policy. Failure on the part of seller to inform dispatch particulars will make him liable to pay for any transit damages / losses suffered by the Purchaser.
- b) If Quoted Prices are inclusive of transit insurance, no weightage shall be given while evaluating the bids for Cost of Insurance, being in BHEL Scope.

18. RISK PURCHASE.

In case of abnormal delays (beyond the maximum late delivery period as per Penalty clause) in supplies / defective supplies or non-fulfillment of any other terms and conditions given in

Purchase Order, BHEL may cancel the Purchase Order in full or part thereof, and may also make the purchase of such material from elsewhere / alternative source at the risk and cost of the supplier. BHEL will take all reasonable steps to get the material from alternate source at optimum cost. If bidder does not agree to the above Risk Purchase Clause, BHEL reserves the right to reject the offer. In case for compelling reasons BHEL accepts the offer without acceptance of this clause by the bidder and in the eventuality of Risk Purchase, appropriate action will be taken as per BHEL extant rules. This will be without prejudice to any other right of BHEL under the contract or under General Law.

19. FORCE MAJEURE CLAUSE.

Notwithstanding any other thing contained anywhere else in the contract or PO (Purchase Order), In case the discharge of obligation under the contract by either party is impeded or made unreasonably onerous, neither party shall be considered in breach of the contract to the extent that performance of their respective obligation is prevented by an event of Force Majeure that arises after the effective date (PO date).

In the above clause, Force Majeure means an event beyond the control of the parties to the contract which prevents a party from complying with any obligation of the contract including but not limited to:

- Act of God (Such as but not limited to earthquake, drought, tidal waves, floods etc.).
- War (whether war be declared or not), Hostilities Invasion, Act of foreign enemy etc.
- Rebellion, revolution, insurrection, civil war etc.
- Contamination of Radio Activity from any nuclear fuel or from any other nuclear waste or any other hazardous materials.
- Riots, commotions, strike unless restricted to the employees of supplier.
- Acts of terrorism.
- Other unforeseeable circumstances beyond the control of the parties and which the affected party cannot avoid even by using its best efforts.
- Cancellation of contract by customer.



BHARAT HEAVY ELECTRICALS LIMITED

HEEP-HARIDWAR, UTTARAKHAND (249403)

General Instructions and Standard Terms & Conditions for bidding against Tender Enquiry (GISTC)

For Indian Bidders (Version June-2021, Rev: 06)

- i) Change in law / government. Regulation making the performance impossible.
- j) Pandemic or Epidemic.

The party claiming to be affected by force majeure shall notify the other party in writing immediately without delay on the intervention and on the cessation of such circumstances.

Irrespective of any extension of time, if an event of force majeure occurs and its effect continues for more than 180 days the affected party shall have right to cancel the contract.

As soon as reasonably practicable following the date of commencement of a Force Majeure Event, and within a reasonable time following the date of termination of a Force Majeure Event, either Party invoking it shall submit to the other Party reasonable proof of the nature of the Force Majeure Event and of its effect upon the performance of the Party's obligations under this Agreement.

The party shall, and shall ensure that its Subcontractors shall, at all times take all reasonable steps within their respective powers and consistent with Good Operating Practices (but without incurring unreasonable additional costs) to:

- a) Prevent Force Majeure Events affecting the performance of the party's obligations under this Agreement.
- b) mitigate the effect of any Force Majeure Event and
- c) Comply with its obligations under this Agreement.

If the war like situation has developed in a country where a seller's works is located in this P.O. or there is political instability and Indian Embassy located in that country forbids or advises for not having any business dealing with the sellers located in such zone / region/ country, then BHEL reserves the right to cancel the order.

20. NON-DISCLOSURE AGREEMENT.

All Drawing and Technical Documents relating to the product or it's manufacture submitted by one party to the other, prior or subsequent to the formation of contract, shall remain property of the submitting party. Drawing, technical documents or other technical information received by one party, shall not without the consent of the other party, be used for any other purpose than

that, for which they were provided. Such technical information shall not without the consent of the submitting party, otherwise be used or copied, reproduced, transmitted or communicated to a third party. Patterns supplied by BHEL will remain BHEL's property which shall be returned by the bidder on demand to BHEL. Bidder shall in no way share or use such intellectual property of BHEL to promote his own business with others or to make a commercial advantage. BHEL reserves the right to claim damages from the bidder, or take appropriate action as deemed fit against the bidder, for any infringement of the provisions contained herein as available under law or equity.

21. SETTLEMENT OF DISPUTES / ARBITRATION.

In case of any dispute arising out of as in connection with this contract, the same shall be referred to arbitration under Arbitration & Conciliation Act 1996 of a sole arbitrator who shall be appointed by mutual consent of the parties. The seat & venue of arbitration shall be Haridwar.

The proceedings shall be conducted in English. The Governing law of contract shall be the substitutive law of India.

22. WHARFAGE / DEMURRAGE RESPONSIBILITY.

In the event of delay in receipt of documents by Manager (Stores-Shipping) BHEL-Haridwar and in case where dispatches are made through Unapproved Transporter the sole responsibility for wharfage / demurrage for such delay shall be that of supplier.

23. CONDITIONS FOR AVAILING MICRO & SMALL ENTERPRISES (MSE'S) BENEFITS.

- a) "MSE Suppliers can avail the intended benefits only if they submit along with the offer, attested copies of either EM II certificate having deemed validity (**five years** from the date of issue of acknowledgement in EM II) or valid NSIC certificate or EM II certificate along with attested copy of a CA certificate (Format enclosed at annexure-1 where deemed validity of EM II certificate of five years has expired) applicable for the relevant financial year (latest audited). Date to be reckoned for determining the deemed validity will be the date of bid



BHARAT HEAVY ELECTRICALS LIMITED

HEEP-HARIDWAR, UTTARAKHAND (249403)

General Instructions and Standard Terms & Conditions for bidding against Tender Enquiry (GISTC)

For Indian Bidders (Version June-2021, Rev: 06)

opening (Part 1 in case of two-part bid) or vendor has to give Udyog Adhar Memorandum (UAM). Non submission of such documents will lead to consideration of their bid at par with other bidders. No benefit shall be applicable for this enquiry if any deficiency in the above required documents is found or the requisite documents are not submitted before price bid opening. If the tender is to be submitted through e-procurement portal, then the above require document are to be uploaded on the portal. Documents should be notarized or attested by a Gazetted officer. **UAM need not required to be notarized or attested.**

b) Any new supplier will be eligible for registration with BHEL as MSE supplier provided at least any one of the following documents are submitted along with application for registration: -

1. Udyog Adhar Memorandum (UAM).
2. Valid National Small Industries Commission (NSIC) Certificate.
3. Entrepreneurs Memorandum part II (EM II) certificate (valid based on deemed validity of 5 years) or
4. EM II certificate along with attested copy of CA Certificate (as per prescribed format at annexure-A) applicable for the relevant financial year (latest audited), where the deemed validity of EM II is over.
5. However, credentials of all MSE suppliers will be verified before advancing the intended benefits.
6. MSE bidders claiming SC/ST status will have to submit SC/ST certificate of the Proprietor from competent authority. Attested (notarized or attested by Gazetted officer) copy to be submitted along with the offer.
7. In case techno-commercial accepted bidders include MSE source and their prices (based on landed cost – considering quoted prices) are within the price band of 15% w.r.t. L-1 bidder, then BHEL can offer **25%** of quantity of respective item (rounded off to nearest number) to MSE bidders at L-1 price and in case, more than one MSE bidder is in 15 % band and the same is accepted by more than one MSE bidders then **25%** quantities of respective items will be considered for ordering on proportionate basis amongst MSE bidders.
8. There will be minimum of **3%** reservation for women owned MSEs within the above mentioned 25% reservation.

9. The reservation for MSEs owned by SC/ST will be **6.25%** { 25% out of target of 25% - refer para 4 of Public Procurement Policy for the Micro and Small Enterprises(MSEs)}.
10. The definition of MSEs owned by Women Entrepreneurs is clarified as under:
 - a) In case of proprietary MSE, proprietor shall be Woman.
 - b) In case of partnership MSE, the Woman partners shall be holding at least 51% of share in the unit.
 - c) In case of Private Limited companies, at least 51% share shall be held by Women promoters.
11. The definition of MSEs owned by SC/ST is clarified as under:
 - a) In case of proprietary MSE, proprietor(s) shall be SC/ST.
 - b) In case of partnership MSE, the SC/ST partners shall be holding at least 51% of shares in the unit.
 - c) In case of Private Limited companies, at least 51% share shall be held by SC/ST promoters.
12. While distributing the **25%** quantity amongst MSE bidders the decimal points in quantity shall be ignored for all the bidders except the L-1 amongst MSE bidders. Balance quantity after allocating the quantity to other MSE bidders ignoring the quantities in decimal, shall be given to L-1 (amongst MSE) bidder. However, if there are more than one MSE bidder at the same price level than preference for additional quantities due to ignoring off the decimal (as mentioned above) shall be given to the bidder offering favorable terms to BHEL and if the conditions offered are also same then preference will be given to the bidder having high SPR rating.
13. In case there are more than one MSE bidders (with different landed cost to BHEL) within 15% price band of lowest bidder and quantity to be offered is 1 no. only, then preference shall be given to the MSE bidder with lowest landed cost.
14. In case there are more than one MSE bidders (with same landed cost to BHEL) within 15% price band of lowest bidder and quantity to be offered is 1 no. only, then preference shall be given first, based on the favorable terms in the bid and in case terms are also same, the bidder with high SPR rating shall be given preference.
15. If L1 bidder is MSE bidder, entire quantity will be given to such MSE bidder only.
16. Note: It may however be noted that MSE guidelines as on date (Date of Technical Bid Opening Part-1) shall prevail.



BHARAT HEAVY ELECTRICALS LIMITED

HEEP-HARIDWAR, UTTARAKHAND (249403)

General Instructions and Standard Terms & Conditions for bidding against Tender Enquiry (GISTC)

For Indian Bidders (Version June-2021, Rev: 06)

17. "As per the OM No. F.No. 1(2)(1)/2016-MA dtd. 09.02.2017 issued from the Office of Development Commissioner (Micro, Small & Medium Enterprises), "Traders and agents should not be allowed to avail the benefits extended under the PP Policy."

In view of this, it is clarified that benefits of MSE (such as EMD Waiver, Tender fee exemption, Price preference, Payment preference etc.) will be given only to those MSE Vendors who are manufacturers of offered items against the NIT. No MSE benefits shall be provided to Agents / Stockists / Dealers / Traders etc. for the items offered but not manufactured by themselves."

24. INFORMATION TO THE BIDDERS.

- a) Purchase related information is available at our Business-to-Business (B2B) Portal available on our website <https://hwr.bhel.com>. The user ID & password can be obtained by sending a request to concerned purchase executives.
- b) Intimate your change in mail address or communication address or changes, if any, by email to AGM (SDX/MM) giving your bidder Code.
- c) Please resolve your rejections and unexecuted overdue purchase order immediately which are posted at our B2B Portal, which can be visited through our site <https://hwr.bhel.com>
- d) Copy of this Tender Enquiry is being sent through the post.
- e) The Bidder declares that they will not enter into any illegal or undisclosed agreement or understanding, whether formal or informal with other bidder(s). This applies in particular to prices, specifications, certifications, subsidiary contracts, submission or non-submission of bids or any other actions to restrict competitiveness or to introduce cartelization in the bidding process.
In case, the bidder is found having indulged in above activities, suitable action shall be taken by BHEL as per extant policies/guidelines.
- f) Supplier must upload digitally signed e-Invoice on B2B portal for processing of Bills.

In other cases, inked signed hard copy of Invoice to be submitted for processing of Bills.

25. MAKE IN INDIA (GOVT-NOTIFICATION).

- A. This tender enquiry shall be governed by notification no. P-45021/2/2017-PP (BE-II) dated 04.06.2020 of government of INDIA and subsequent circulars issued afterwards. Accordingly, the minimum local content, the margin of purchase preference and the procedure for preference to make in INDIA shall be adhered.
- B. The margin of purchase preference shall be 20%.
 - 'Class-I local Supplier' means a supplier or service provider, whose goods, services or works offered for procurement, has local content equal to or more than 50%, as defined under this order.
 - 'Class-II local Supplier' means a supplier or service provider, whose goods, services or works offered for procurement, has local content more than 20% but less than 50%, as defined under this order.
 - 'Non- local Supplier' means a supplier or service provider, whose goods, services or works offered for procurement, has local content less than or equal to 20%, as defined under this order.
- C. Vendor to specifically confirm if they are Class-I or Class-II local supplier or not as per above mentioned notification. Accordingly, the 'Class-I local supplier' / 'Class-II local Supplier' at the time of tender, bidding or solicitation shall be required to indicate percentage of local content and provide self-certification that the item offered meets the local content requirement for 'Class-I local supplier' / 'Class-II local Supplier', as the case may be. They shall also give details of the location(s) at which the local value addition is made.
- D. In cases of Procurement for a Value in Excess of Rs. 10 Crores, the 'Class-I local supplier' / 'Class-II local Supplier' shall be required to provide a Certificate from the Statutory Auditor or Cost Auditor of the Company (in the case of companies) or from a practicing Cost Accountant or practicing Chartered Accountant (in respect of suppliers other than companies) giving the percentage of Local Content.
- E. Requirement of Purchase Preference:



BHARAT HEAVY ELECTRICALS LIMITED

HEEP-HARIDWAR, UTTARAKHAND (249403)

General Instructions and Standard Terms & Conditions for bidding against Tender Enquiry (GISTC)

For Indian Bidders (Version June-2021, Rev: 06)

Purchase preference shall be given to 'Class-I local supplier' in procurements undertaken by procuring entities in the manner specified hereunder -

a. In the procurements of goods or works, which are covered by para 3(b) of mentioned Govt. circular and which are divisible in nature, the 'class-I local supplier' shall get purchase preference over 'Class-II supplier' as well as 'Non-local supplier', as per following procedure:

- i. Among All qualified bids, the lowest bid will be termed as L1. If L1 is 'Class-I local supplier', the contract for full quantity will be awarded to L1.
- ii. If L1 bid is not a 'Class-I local supplier', 50% of the order quantity shall be awarded to L1. Thereafter, the lowest bidder among the 'Class-I local supplier' will be invited to match the L1 price for the remaining 50% quantity subject to the class-I local supplier's quoted price falling within the margin of purchase preference, and contract for that quantity shall be awarded to such 'Class-I local supplier' subject to matching the L1 price. In case such lowest eligible 'Class-I local supplier' fails to match the L1 price or accepts less than the offered quantity, the next higher 'Class-I local supplier' within the margin of purchase preference shall be invited to match the L1 price for remaining quantity and so on, and contract shall be awarded accordingly. In case some quantity is still left uncovered on Class-I local supplier, then such balance quantity may also be ordered on the L1 bidder".

b. In the procurements of goods or works, which are covered by para 3(b) of mentioned Govt. circular and which are not divisible in nature, and in procurement of services where the bid is evaluated on price alone, the 'class-I local supplier' shall get purchase preference over 'Class-II supplier' as well as 'Non-local supplier', as per following procedure:

- i. Among all qualified bids, the lowest bid will be termed as L1. If L1 is 'Class-I local supplier', the contract will be awarded to L1.
- ii. If L1 is not 'Class-I local supplier', the lowest bidder among the 'Class-I local supplier', will be invited to match the L1 price subject to Class-I local supplier's quoted price falling within the margin of purchase preference,

and the contract shall be awarded to such 'Class-I local supplier' subject to matching the L1 price.

- iii. In case such lowest eligible 'Class-I local supplier', fails to match the L1 price, the 'Class-I local supplier' with the next higher bid within the margin of purchase preference shall be invited to match the L1 price and so on and contract shall be awarded accordingly. In case none of the 'Class-I local supplier' within the margin of purchase preference matches the L1 prices, the contract may be awarded to the L1 bidder.

c. 'Class-II local supplier' will not get purchase preference in any procurement, undertaken by procuring entities.

F. For this procurement, the local content to categorize a supplier as a Class-I local supplier/ Class-II local supplier/ Non-local supplier and purchase preference to Class-I local supplier, is as defined in Public Procurement (Preference to Make in India), Order 2017 dated 04.06.2020 issued by DPIIT. In case of subsequent orders issued by nodal ministry, changing the definition of local content for the items of the NIT, the same shall be applicable even if issued after issue of this NIT, but before opening of Part-II bids against this NIT.

G. Procurements where estimated value to be procured is less than Rs. 5 lakhs shall be exempted from GOI order No. P-45021/2/2017-PP (BE-II) dated 04.06.2020.

H. For procurement of Goods & Services which are divisible in nature, following shall be operated for **MSE bidders** under Public procurement Policy for the Micro and Small Enterprises (MSEs) Amendment Order, 2019, Ref. No. AA: SSP: MSE: Amndt, dtd. 30.11.2018, Circular No. 44 of 2018-19;-

a. If L1 bid is not from "Class-I local Supplier" and price quoted by MSE bidder falls within the margin of Purchase preference (L1+15% for MSEs), then 25 % of total order quantity of respective item (rounded off to nearest number) shall be awarded to MSE bidder, subject to MSE bidder matching the L1 Price. Out of Remaining 75% quantity, distribution shall be operated as per below sub-clause (2) –

b. If "Class- I Local Supplier" (Next to L1, other than MSE) quoted price falling within the Margin of Purchase Preference, and "Class-I local supplier" matches the L1 price, then 50% of remaining Quantity (after allocation of 25% to



BHARAT HEAVY ELECTRICALS LIMITED

HEEP-HARIDWAR, UTTARAKHAND (249403)

General Instructions and Standard Terms & Conditions for bidding against Tender Enquiry (GISTC)

For Indian Bidders (Version June-2021, Rev: 06)

MSE) i.e. 37.5% shall be awarded to local supplier and 37.5% shall be awarded to foreign bidder.

Note: L1 Price refers to lowest evaluated / landed cost to Company.

For Further details, please refer GOI order no. P-45021 / 2 / 2017 - PP (BE-II) dated 04.06.2020.

26. RESTRICTIONS UNDER RULE 144(XI) OF THE GENERAL FINANCIAL RULES (GFRs), 2017

All provisions of Order No. F.No.6/18/2019-PPD of Department of Expenditure (DoE) shall be applicable for this tender enquiry (Order copy is available at <https://doe.gov.in/procurement-policy-divisions>). Accordingly, any bidder from a country which shares a land border with India (except the countries to which the Govt. of India has extended lines of credit or in which the Govt. of India is engaged in development projects for which list is available at <https://www.mea.gov.in/>) will be eligible to bid in this tender only if the bidder is registered with the Competent Authority as specified in Annex I of the said Order of DoE.

Updated list of the countries to which lines of credit have been extended or in which development projects are undertaken are available on the Ministry of External affairs website (<https://www.mea.gov.in/>)

For the purpose of this order, definition of Bidder from a country which shares a land border with India shall be same as defined in the Annex III of the said order.

Registration with the competent authority as stipulated in the said order is responsibility of bidder. Bidder has to submit a certificate certifying following along with offer:

"I have read the clause regarding restrictions on procurement from a bidder of a country which shares a land border with India; I certify that bidder (.... Name of Bidder) is not from such a country or, if from such a country, has been registered with the Competent Authority. I hereby certify that bidder (.....Name of bidder) fulfils all requirements in this regard and is eligible to be considered"

If the bidder is from such country which shares a land border with India evidence of valid registration by the Competent Authority shall also be attached along with offer."

27. NOTE.

- a) Special conditions of enquiry, if enclosed by BHEL, will supersede the respective standard / general terms of enquiry.
- b) Any other Standard terms and Conditions of the bidder attached / referred against the tender enquiry will be treated as null and void ab initio.
- c) In order to protect the commercial interests of BHEL, it becomes necessary to take action against suppliers / contractors by way of suspension of business dealings, who either fail to perform or are in default without any reasonable cause, cause loss of business / money / reputation, indulged in malpractices, cheating, bribery, fraud or any other misconducts or formation of cartel so as to influence the bidding process or influence the price etc. Guide- lines for Suspension of Business Dealings with Suppliers / Contractors shall prevail over which is available at BHEL website <http://www.bhel.com>
- d) The bidder along with its associate / collaborators / sub-contractors / sub-vendors / consultants / service providers shall strictly adhere to BHEL Fraud Prevention Policy displayed on BHEL website <http://www.bhel.com> and shall immediately bring to the notice of BHEL-Management about any fraud or suspected fraud as soon as it comes to their notice.
- e) "BHEL shall recover the amount of compensation paid to victim(s) by BHEL towards loss of life / permanent disability due to an accident which is attributable to the negligence of contractor, agency or firm or any of its employees as detailed below;
 1. **Victim:** Any person who suffers permanent disablement or dies in an accident as defined below.
 2. **Accident:** Any death or permanent disability resulting solely and directly from any unintended and unforeseen injurious

Quotations / Bids not in accordance with General Instructions and Standard Terms & Conditions are likely to be ignored.



BHARAT HEAVY ELECTRICALS LIMITED

HEEP-HARIDWAR, UTTARAKHAND (249403)

General Instructions and Standard Terms & Conditions for bidding against Tender Enquiry (GISTC)

For Indian Bidders (Version June-2021, Rev: 06)

occurrence caused during the manufacturing / operation and works incidental thereto at BHEL factories/ **offices and precincts** thereof , project execution , erection and commissioning, services, repairs and maintenance, trouble shooting, serving , overhaul, renovation and retrofitting , trial operation, performance guarantee testing undertaken by the company or during any works / during working at BHEL Units/ Offices/ townships and premises/ project sites.

3. Compensation in respect of each of the victims:

- (i) In the event of death or **permanent disability** resulting from **Loss of both limbs**: Rs. 10,00,000/- (Rs. Ten Lakh).
- (ii) In the event of **other permanent disability**: Rs. 7,00,000/- (Rs. Seven Lakh).

4. Permanent Disablement: A disablement that is classified as a permanent total disablement under the proviso to Section 2(l) of the Employees Compensation Act, 1923.”

f) The bidder shall be in compliance with applicable laws, rules and regulations throughout the terms of the contract for conducting its business generally and to perform its obligations under this contract.

Certificate

In line with Government Public Procurement Order No. P-45021/2/2017-BE-II dt. 15.06.2017 & P-45021/2/2017-PP (BE-II) dated 28.05.2018, we hereby certify that we M/s _____(supplier name) are local supplier meeting the requirement of minimum local content (50%) as defined in above orders for the material against Enquiry No. _____

Details of location at which local value addition will be made is as follows:

We also understand, false declarations will be in breach of the Code of Integrity under Rule 175(1)(i)(h) of the General Financial Rules for which a bidder or its successors can be debarred for up to two years as per Rule 151 (iii) of the General Financial Rules along with such other actions as may be permissible under law.

Seal and Signature of Supplier

