

Scope of Supply

Sl. No	Material Code	Material Description	Quantity (Nos)	Drawings
10	220737550000	Name Plate - Blank	5630	BPS O175371555/00
20	964640320000	INSTRUCTION PLATE -GREASE-4124	5000	4V412407706/01
30	964528340000	INDICATOR PLATE FOR FBV HANDWHEEL-4362	5000	4V436207660/01
40	964564920000	NAME PLATE-5310	3000	4V531006821/01
50	220745660000	NAME PL 20X75-BPS 017537	3000	BPS 017537
60	964529890000	NAME PLATE-5205	2000	4V520506503/03
70	964529870000	NAME PLATE-5740	1500	4V574006462/03
80	964660630000	NAME PLATE	1000	4VG00419240/00
90	220735990000	NAME PLATE F/ XMT ASSY COMPONENTS - 4015	1000	4V401507075/04
100	964560050000	NAME PLATE-5938	1000	4V593806508/02
110	220741660000	NAME PLATE 20X80-BPS:017522	600	BPS:017522
120	964565160000	NAME PLATE-5903	600	4V590306861/01
130	220735510000	NAME PL-9000	600	4V900013007/05
140	964564980000	NAME PLATE-5313	500	4V531306832/01
150	964564910000	NAME PLATE-5904	1200	4V590406820/01
160	964565830000	NAME PLATE-5942	500	4V594206903/01
170	220736470000	RATING PLATE - LRSB 180X108	300	BPS 017202 - BRASS
180	964150410000	CAUTION TAG-7000	400	4V700010046/01

Scope of Supply

Sl. No	Material Code	Material Description	Quantity (Nos)	Drawings
190	964653550000	NAME PLATE-H957	400	4VH95726844/00
200	966000550000	NAME PLATE-SELQ	300	4VSELQ27349/00
210	964643770000	NAME PLATE F / 6A SSV-4762	250	4V476207871/05
220	964643780000	NAME PLATE F / 6A SSV ACTUATOR-4751	250	4V475107872/05
230	220741280000	NM DIRECTION PLATE 20X75 BPS 017510	250	BPS 017510
240	964150500000	RING POSN TAG-7000	250	4V700010097/00
250	964654990000	NAME PLATE-H992	225	4VH99227004/00
260	964560450000	NAME PLATE-5324	100	4V532406534/02
270	964643860000	INSTN.PLATE-4752	150	4V475207905/00
280	220735520000	NAME PLATE-7000	450	4V700010001/06
290	964564930000	NAME PLATE-5801	200	4V580106825/01
300	964150190000	CAUTION PL-7000	200	4V700010053/00
310	964150210000	TAG-STEEL241215-7000	200	4V700010052/00
320	966000670000	NAME PLATE-SFFQ	150	4VSFFQ27448/00
330	964565150000	NAME PLATE-5727	150	4V572706860/01
340	220735720000	NAME PLATE-5610	100	4V561006024/00
350	964653670000	NAME PLATE-HC07	120	4VHC0726850/00
360	964560080000	NAME PLATE-5946	100	4V594606511/02
370	964653660000	NAME PLATE-HA07	120	4VHA0726849/00

Scope of Supply

Sl. No	Material Code	Material Description	Quantity (Nos)	Drawings
380	964560060000	NAME PLATE-5943	300	4V594306509/02
390	964566120000	NAME PLATE-CR13-HF-HF-5907	110	4V590706914/01
400	964161250000	WARNING TAG	100	4V730110594/00
410	964560180000	NAME PLATE-5914	100	4V591406518/02
420	964532980000	CIR NAME PL.(ST.STEEL)-W345	100	3VW34520825/02
430	964651740000	NAME PLATE-3222	100	4V322226545/00
440	964652300000	NAME PLATE-3246	80	4V324626698/00
450	220746870000	NAME PL.FOR RB	80	BPS 017205
460	964564990000	NAME PLATE-5906	75	4V590606849/01
470	220747210000	CAUTION PL-D.CLU	75	BPS:017544
480	964564890000	NAME PLATE-5326	75	4V532606818/01
490	964650650000	NAME PLATE-H413	50	4VH41326335/00
500	964651290000	NAME PLATE-H631	50	4VH63126417/00
510	964560990000	NAME PLATE-5603	50	4V560306539/02
520	964568220000	NAME PLATE-M766	50	4VM76626042/00
530	964653800000	NAME PLATE-H456	40	4VH45626933/00
540	964533000000	CIR NAME PL.(ST.STEEL)-G001	40	3VG00120825/01
550	220736080000	NAME PLATE-7501	40	4V750110004/03
560	964650640000	NAME PLATE-5557	40	4V555726331/00

Scope of Supply

Sl. No	Material Code	Material Description	Quantity (Nos)	Drawings
570	964560240000	NAME PLATE-5937	30	4V593706524/02
580	964562140000	NAME PLATE-5213	25	4V521306670/01
590	964564900000	NAME PLATE-5928	25	4V592806819/01
600	964645300000	NAME PLATE F/T.P BUSHING-4176	25	4V417607980/00
610	220736050000	NAME PLATE VENT-7501	25	4V750110158/00
620	964663600000	NAME PLATE-LD01	20	4VLD0119496/00
630	964561810000	NAMEPLATE-5651	20	4V565106622/01
640	964562170000	INDICATR 18.8 SS-5620	20	4V562006691/00
650	964605330000	INDICATOR PLATE-L905	15	4VL90520037/00
660	220747230000	NPL LRNR	15	42040103987/00
670	964536620000	NAME PLATE-5871	15	4V587126249/00
680	964560440000	NAME PLATE-5835	10	4V583506533/02
690	964568190000	NAME PLATE-H285	10	4VH28526039/00
700	964568580000	NAME PLATE-5554	10	4V555426061/00
710	964562200000	NAME PLATE-5955	10	4V595506698/01

*The quantities mentioned in the enquiry are indicative for the entire Rate Contract (RC) period

BHARAT HEAVY ELECTRICALS LIMITED
Tiruchirapalli-620014

Pre-Qualification Requirement (To be submitted in Part-I bid)

1. Vendor shall be OEM only. Reseller/dealer/traders shall not be eligible to participate: To fulfil this criteria vendor shall submit self-declaration certificate on company letterhead.
2. Vendor to furnish records of previous supplies of same or similar category items to any Central / State Govt Organization / PSU / Public Listed Company: To fulfil this criteria vendor shall submit previous records not more than 5 years old from date of part 1 bid opening.
3. Vendor should manufacture the items as per BHEL drawing and specification. To fulfil this criteria vendor shall submit the drawings and specifications duly sealed and signed.



BHARAT HEAVY ELECTRICALS LTD

VALVES PURCHASE

Trichy - 620 014. India

CONFIRMATION TO TERMS AND CONDITIONS

Enquiry Reference: **RCPBNM2329**

<u>TERMS & CONDITION</u>	<u>VENDOR CONFIRMATION</u>
a. Vendor Quotation Ref No and Date	
b. Rate Contract: This is an enquiry for the finalization of a Rate Contract (RC) for a period as mentioned in 'Validity of offer' below. The quantities mentioned in the enquiry are indicative for the entire RC period. Purchase Orders will NOT be issued for the entire quantum in one lot, whereas POs will be released on a time to time basis during the RC period, based on actual requirement.	
c. Vendor should give confirmation to BHEL's Technical Specification. Any deviations from the specification are to be furnished separately as "Schedule of Deviation". If there is no deviation vendor should indicate "No Deviation".	
d. The offer has to be submitted as a Two-part bid (Techno-commercial & Price bid)	
e. The tender will be finalized on item wise basis	
f. Terms of Payment: <u>Indigenous Supplier (Non-MSE):</u> 100% direct EFT Payment after 60 days from the date of receipt and acceptance of materials at BHEL stores / against site acknowledgement. <u>Indigenous Supplier (MSE):</u> Payment will be as per MSMED Act, 2006	
g. Liquidated Damage: Liquidated damages shall be 0.5% of the undelivered portion per week of the delay or part thereof subject to a maximum of 10% of the total order value.	
h. Delivery Terms: Prices shall be quoted on " FIRM PRICE " basis only. <u>For Indigenous Supplies:</u> FOR BHEL Trichy	
i. Validity of Offer: Prices should be valid for 9 months from the date of finalisation of the rate contract or 12 months from the date of part-1 bid opening , whichever is earlier.	
j. Delivery period: Delivery period should be 8 weeks from the date of purchase order. If supplier offers more than the required delivery period BHEL will operate 0.5% loading factor for evaluation of their offer for every week delay subject to a maximum of 2%. Any other delivery period after loading to maximum will be rejected.	



BHARAT HEAVY ELECTRICALS LTD

VALVES PURCHASE

Trichy - 620 014. India

CONFIRMATION TO TERMS AND CONDITIONS

Enquiry Reference: **RCPBNM2329**

<u>TERMS & CONDITION</u>	<u>VENDOR CONFIRMATION</u>
<p>k. Risk Purchase: Risk purchase penalties as per clause 5 of general terms and conditions is applicable for this enquiry. Non acceptance to risk purchase clause the offer is liable for rejection.</p>	
<p>l. Guarantee Clause: The vendor shall give a guarantee for the performance of his supplies for a period of eighteen months from the date of dispatch or twelve months from the date of commissioning whichever is earlier.</p> <p>Any warranty replacement during warranty period shall be supplied free of charge on FOR Site basis/destination specified by BHEL</p>	
<p>m. Performance Bank Guarantee: Performance Bank Guarantee is not applicable for this enquiry</p>	
<p>n. Counter-offering Counter-offering is not applicable for this enquiry</p>	
<p>o. Integrity Pact Integrity pact is not applicable for this enquiry</p>	



BHARAT HEAVY ELECTRICALS LTD

VALVES PURCHASE

Trichy - 620 014, India

GENERAL TERMS AND CONDITIONS

Enquiry Reference: **RCPBNM2329**

1. QUOTATIONS:

- a. **BID system:** The no. of bids to be submitted is mentioned in "Confirmation to the Terms and Conditions" attached.
 - i. **Two part bid:** The offers are invited in Two part bid system (Part I will be Techno-commercial bid and part II will be Price Bid). Techno-commercially suitable vendors alone will be intimated for price bid opening.
- b. **Submission of offer:**
 - i. **Offer called through e-Procurement mode:** The bidder shall submit the bid online in BHEL e-Procurement portal at <https://eprocurebhel.co.in/>

The bidder would be required to register on the above e-procurement portal for submitting their bids. Offers through email and hardcopy are not acceptable.

- c. **Regulations:** Offers should be free from correction and erasures. Corrections if any must be attested. All amounts shall be indicated both in words as well as figures. In case of a difference between the amount quoted in words and figures, the amount quoted in words shall prevail.
- d. **PVC:** Price Variation clause not acceptable. Prices should be firm.
- e. **Catalogue:** Manufacturer's name, Trade Mark or Patent No. if any should be specified. Illustrative leaflets giving technical particulars are required along with quotation.
- f. **Samples:** Samples should be submitted separately, if specially requested in tender, before the due date of the enquiry. They should be clearly marked with the enquiry reference and date on the enclosing cover to facilitate identification.
- g. **GST Number:** GST registration number, HSN number (Item wise) with applicable taxes should be mentioned in the offer. If the vendor is not GST registered the offer is liable for rejection.
- h. **Deviation.** Any deviations from the specification are to be furnished separately as "Schedule of Deviation". If there is no deviation, vendor should indicate "No Deviation" in the offer.
- i. **Confirmation:** Confirmation for compliance is to be given in the offer for all the techno commercial conditions specified in the tender.

2. COMMERCIAL TERMS & CONDITIONS:

a. **Terms of Payment:**

For Indigenous Suppliers:

If the materials are receivable at BHEL Stores, Trichy:

Payment term is 100% direct Payment after 60 days from the date of receipt and acceptance of materials. (if PBG is not applicable)

(or)

Payment term is 100% direct payment after 60 days from the date of receipt and acceptance of materials and against 10% PBG valid for the warranty period. (if PBG is applicable)

If the materials are receivable at site:

Payment term is 100% direct payment after 60 days from the date of dispatch against site acknowledgement (if PBG is applicable)

(or)

Payment term is 100% direct payment after 60 days from the date of dispatch against site acknowledgement and against 10% PBG valid for the warranty period (if PBG is applicable)

Any deviation in the above payment terms, any other conditions in payment terms or any other payment terms will not be accepted and offers will not be considered.

For New Suppliers: For new suppliers not registered with BHEL, Trichy for the product, payment shall be made 60 days after receipt and acceptance of materials.

- b. **Liquidated Damage:** Liquidated damages shall be 0.5% of the undelivered portion per week of the delay or part thereof subject to a maximum of 10% of the total order value.



BHARAT HEAVY ELECTRICALS LTD

VALVES PURCHASE

Trichy - 620 014, India

GENERAL TERMS AND CONDITIONS

Enquiry Reference: **RCPBNM2329**

- c. Any deviation from the above LD clause, loading will be applied to the extent to which it is not agreed by the bidder (at offered value)

Under GST regime, BHEL has to discharge GST liability on LD recovered from suppliers. Hence applicable GST shall also be recoverable from suppliers on LD amount. Debit note will be issued by BHEL for this amount, indicating the respective supply invoice number.

d. Delivery Terms:

For Indigenous Suppliers: FOR BHEL Trichy inclusive of freight and insurance

For Foreign Suppliers: CFR/CIF Chennai seaport as per Incoterms 2010.

- e. **Validity of Offer:** Prices should be fixed and should be valid for period as mentioned in the "Confirmation to the Terms and Conditions" attached.
- f. **Delivery period:** Delivery schedule will be as mentioned in the "Confirmation to the Terms and Conditions" attached.
- g. **Guarantee period:** The vendor shall give a guarantee for the performance of his supplies for a period of **eighteen months** from the date of dispatch or **twelve months** from the date of commissioning whichever is earlier.
- h. **Miscellaneous:** Any conditions which might have been quoted by the seller and are in contravention to the terms of PO and which have not been specifically accepted by Purchaser will not be applicable to the contract/PO.
- i. **Performance Bank Guarantee:** If tender calls for Performance Bank Guarantee, vendor should provide a performance bank guarantee (PBG) in BHEL format for 10% of the total Purchase order value valid for warranty/guarantee period with an additional claim period of 2 months. PBG should be issued from list of consortium banks.

3. COMPLIANCE / ACCEPTANCE REQUIRED FOR FOLLOWING POINTS TO ENSURE INPUT TAX CREDIT

- a. Response to Tenders for Indigenous supplier/Vendor will be entertained only if the vendor has a valid GST registration No (GSTIN) which should be clearly mentioned in the offer. If the Vendor is exempted from GST registration, a declaration with due supporting documents need to be furnished for considering the offer. Vendor under composition scheme should declare that he is a composition Vendor supported by the screen shot taken from GST portal. The dealer has to submit necessary documents if there is any change in status under GST.
- b. Supplier shall mention their GSTIN in all their invoices (incl. credit Notes, Debit Notes) and invoices shall be in the format as specified/prescribed under GST laws. Invoices shall necessarily contain Invoice number (in case of multiple numbering system is being followed for billing like SAP invoice no, commercial invoice no etc., then the Invoice No. which is linked/uploaded in GSTN network shall be clearly indicated), Billed to party (with GSTIN) & Shipped to party details, item description as per PO, Quantity, Rate, Value, applicable taxes with nomenclature (like IGST, SGST, CGST & UTGST) separately, HSN/ SAC Code, Place of Supply etc.
- c. Invoices will be processed only upon completion of statutory requirement and further subject to following:
- Vendor declaring such invoice in Form GST ANX-1
 - Receipt of Goods or Services and Tax invoice by BHEL
- d. All invoices shall bear the HSN Code for each item separately (Harmonized System of Nomenclature)/ SAC code (Services Accounting Code).
- e. As the continuous uploading of tax invoices in GSTN portal (in GST ANX-1) is available for all (i.e. both Small & Large) tax payers under proposed new GST Return System, all invoice raised on BHEL may be uploaded immediately in GST portal on despatch of material /rendering of services. The supplier shall ensure availability of Invoice in GST portal before submission of invoice to BHEL. Invoices will be admitted by BHEL only if the invoices are available in GSTN portal (in BHEL's GST ANX-2).
- f. A declaration to the effect that all invoice particulars are/were uploaded in the GSTN network/ portal & all tax liability as per GST rules and regulations have been and will be discharged, shall be mentioned in the invoice. If not mentioned in the invoice, a separate declaration shall be submitted as per the requirement of BHEL.
- g. All documents like Test Certificate, LR copy, any other document mentioned in PO, shall be sent along with the vehicle/consignment. For all consignments received within the calendar month, input credit will be availed within that month in line with monthly returns filing cycle. In case of any discrepancy in the document or non-submission of documents mentioned in the PO, then BHEL will not be able to accept or account the material, in such case availing of tax credit will be deferred to next month or so.
- h. In case of discrepancy in the data uploaded by the supplier in the GSTN portal or in case of any shortages or rejection in the supply, then BHEL will not be able to avail the tax credit and will notify the supplier of the same. Supplier has to rectify



BHARAT HEAVY ELECTRICALS LTD

VALVES PURCHASE

Trichy - 620 014, India

GENERAL TERMS AND CONDITIONS

Enquiry Reference: **RCPBNM2329**

the data discrepancy in the GSTN portal or issue credit note or debit note (details also to be uploaded in GSTN portal) for the shortages or rejections in the supplies or additional claims, within the calendar month informed by BHEL.

- i. In cases where invoice details have been uploaded by the vendor but failed to remit the GST amount to GST Department (Form PMT-08 or Form GST RET-01 to be submitted) within stipulated time, then GST paid on the invoices pertaining to the month for which GST return not filed by the vendor will be recovered from the vendor along with the applicable interest (currently 24% p.a) and all subsequent bills of the vendor will not be processed till filing of the GST return by the vendor.
- j. Under GST regime, BHEL has to discharge GST liability on LD recovered from suppliers/contractors. Hence applicable GST shall also be recoverable from suppliers/contractors on LD amount. For this, debit note will be issued by BHEL indicating the respective supply invoice number.
- k. In case any changes in taxes and duties as per Gov. Notification (including GST), the same shall be applicable from time to time.
- l. Duplicate copy of the Invoice meant for the transporter should accompany the material as stipulated under CE Rules 52A and 172C OR 57CE.
- m. TDS on GST shall be applicable as per the GST Act.
- n. In case GST credit is denied to BHEL due to non-receipt or delayed receipt of goods and/ or tax invoice or expiry of timeline prescribed in GST law for availing such ITC, or any other reasons not attributable to BHEL, GST amount claimed in the invoice shall be disallowed to the vendor.
- o. Where any GST liability arising on BHEL under Reverse Charge (RCM), the vendor has to submit the invoices to BHEL well within the timeline prescribed in GST Law, to enable BHEL to discharge the GST liability. If there is a delay in submission of invoice by the vendor resulting in delayed payment of GST by BHEL along with Interest, then such Interest payable or paid shall be recovered from the vendor.
- p. GST TDS will be deducted as per Section 51 of CGST Act 2017 and in line with Notification 50/2018 – Central Tax dated 13.09.2018. GST TDS certificate which will be generated in GST portal subsequent to vendor accepting the TDS deduction in the GST portal, will be issued to the vendor.

4. SPECIAL PROVISIONS FOR MICRO AND SMALL ENTERPRISES (MSE):

- a. 25% of the tendered quantity is earmarked for MSE suppliers in this tender.
- b. If L1 vendor (or) Counter offer accepted vendor/s is from a Micro / Small enterprise which put together covers 25% of the total tendered quantum, the 25% earmarking provision is not applicable.
- c. Out of the 25% tendered quantity reserved for MSE suppliers, 6.25% shall be earmarked for procurement from MSE owned by SC / ST entrepreneurs. In the event of failure of such Micro and Small enterprises to participate in the tender process or meet the tender requirements and the L1 price, the 6.25% sub-target for procurement ear-marked MSE owned by SC / ST entrepreneurs shall be met with other MSE enterprise/s.
- d. 3% reservation for women owned MSEs within the above mentioned 25% reservation. In the event of failure of such Micro and Small enterprises to participate in the tender process or meet the tender requirements and the L1 price, the 3% sub-target for procurement ear-marked MSE owned by women entrepreneurs shall be met with other MSE enterprise/s. The definition for MSEs owned by Women Entrepreneurs is clarified as:
 - i. In case of proprietary MSE, proprietor shall be woman.
 - ii. In case of partnership MSE, the women partners shall be holding at least 51% share in the unit.
 - iii. In case of private limited companies, at least 51% share shall be held by the women promoters.
- e. In case MSE vendor participating in the tender quotes within the price band of LI +15%, they will be allowed to supply the portion of the requirement subject to acceptance of LI price by MSE vendor. In case of more than one such MSE, the supply shall be shared proportionately, provided the available quantum can be split.
- f. In a tender where both MSE and Non-MSE Vendors have participated and non-MSE Vendor has become the lowest bidder and the quantum envisaged in the tender cannot be split, then the MSE vendor will be given preference for ordering the available quantum provided the MSE vendor quoted price is within L1 + 15%, and if the MSE vendor accepts the L1 rate.
- g. MSE suppliers can avail the intended benefits only if,
The vendor submits along with offer, a copy of the Udhog Aadhar and a certificate, as per the format in Annexure-A, issued by a chartered accountant during the financial year of the date of part-1 bid opening, certifying that the quantum of investment in plant and machinery is within the permissible limit as per the act for relevant status (Micro or small).

(or)



BHARAT HEAVY ELECTRICALS LTD

VALVES PURCHASE

Trichy - 620 014, India

GENERAL TERMS AND CONDITIONS

Enquiry Reference: **RCPBNM2329**

The vendor submits along with offer, a copy of the Udyam Registration Certificate.

(or)

The vendor has already submitted the above documents for the financial year of the date of part-1 bid opening and the MSE status has been updated in BHEL Trichy's records.

Non submission of such documents will lead to consideration of their bids at par with other bidders and MSE status of such suppliers shall be shifted to Non MSE supplier till the supplier submits these documents.

h. Definitions of MSEs owned by SC/ST is under:

- i. In case of proprietorship firm, proprietor must be SC/ST.
- ii. In case of partnership firm, the SC/ST partners must be holding at least 51% shares in the unit.
- iii. In case of private limited companies, at least 51% share must be held by SC/ST promoters.
- iv. The caste/Tribe/Community certificate issued by the following authorities in the prescribed form for SCs/STs can be considered.

i. Authorized to Issue SC/ST certificate:

- i. District Magistrate/Additional District Magistrate/Collector/Deputy commissioner/Additional Deputy Commissioner/Deputy collector/1st class stipendiary magistrate/Sub divisional Magistrate/Taluka Magistrate/Executive magistrate/Extra Assistant commissioner.
- ii. Chief Presidency magistrate/Additional chief presidency magistrate/Presidency magistrate.
- iii. Revenue Officer not below the rank of tehsildar.
- iv. Sub-Divisional officer of the area where the individual and / or his family normally resides.

j. To avail the benefits of MSE under SC/ST category, the related documents as stated above should be submitted along with tender documents.

k. Payment for MSE vendors will be as per MSMED Act, 2006.

5. RISK PURCHASE PENALTIES

a. In case of delay in delivery beyond PO delivery /mutually agreed delivery, or vendor fails /refuses to complete the PO as per terms, or insufficient facilities at vendor's works to execute a PO, BHEL has the right to get the items ordered elsewhere at the risk and cost of the vendor with notice to the vendor and the additional expenditure / difference in cost, if any, including consequential cost shall be recovered from the defaulted vendor. Also, in such case of withdrawal of orders, BHEL shall recover the additional expenditure / difference from vendor by adjusting against amount due to vendor and/or by invoking the BG and/or by any other suitable means as decided by BHEL. In addition, BHEL may recover from the defaulter vendor any loss to BHEL arising due to withdrawal of orders in such case, and action shall be taken as per latest revision of BHEL Guidelines for Suspension of Business dealings with Suppliers / Contractors.

b. BHEL has the right to divert/cancel the order if the vendor has not procured minimum 50% of the quantity of raw materials within 60 days from PO date. Purchase order placed on steel mills and with proper payment voucher/proof will be considered for not cancelling the PO by BHEL. The submission of data by vendor for DB clearance by BHEL/QC shall be the proof of procurement. This is to avoid delay in project schedule due to delay in raw material procurement by vendors. In case the vendor fails to procure at least 50% of the quantity of raw materials within 60 days from PO date, BHEL has the right to get the items ordered elsewhere at the risk and cost of the defaulting Vendor and the additional expenditure / difference in cost, if any, including consequential cost shall be recovered from the defaulting Vendor and action shall be taken as per latest revision of BHEL Guidelines for Suspension of Business dealings with Suppliers / Contractors and SEARP.

c. The defaulted vendor shall be liable for any loss, which BHEL may sustain by reason of such risk purchases in addition to liquidated damages as mentioned under LD clause.

d. Vendors pending payments shall be withheld to cover the liabilities of BHEL towards risk purchase, if any.

e. Reasons like power cut, labour issues, machine break down, etc. which are controllable by the sub-contractor shall not be accepted as reason for delay for delivery extension purposes.

f. If PO delivery needs to be extended for reason attributable to BHEL, vendor may request BHEL in writing for delivery extension with justifications within 15 days from date of PO closure and before invoice.

g. Process of calculating the risk and cost amount is as follows:

$$\text{Risk \& Cost Amount} = [(A-B) + (A \times H/100)]$$

Where,

A= Value of Balance scope of Work/ Supply (*) as per rates of new contract



BHARAT HEAVY ELECTRICALS LTD

VALVES PURCHASE

Trichy - 620 014, India

GENERAL TERMS AND CONDITIONS

Enquiry Reference: **RCPBNM2329**

B= Value of Balance scope of Work/ Supply (*) as per rates of old contract being paid to the contractor/ supplier at the time of termination of contract i.e. inclusive of PVC & ORC, if any.

H = Overhead Factor to be taken as 5

In case (A-B) is less than 0 (zero), value of (A-B) shall be taken as 0 (zero).

*(Balance scope of work/ supply)

Difference of Contract Quantities and Executed Quantities as on the date of issue of Letter for 'Termination of Contract', shall be taken as balance scope of Work/ Supply for calculating risk & cost amount. Contract quantities are the quantities as per original contract. If, Contract has been amended, quantities as per amended Contract shall be considered as Contract Quantities. Items for which total quantities to be executed have exceeded the Contract Quantities based on drawings issued to contractor from time to time till issue of Termination letter, then for these items total Quantities as per issued drawings would be deemed to be contract quantities. Substitute/ extra items whose rates have already been approved would form part of contract quantities for this purpose. Substitute/ extra items which have been executed but rates have not been approved, would also form part of contract quantities for this purpose and rates of such items shall be determined in line with contractual provisions. In-case portion of work is being withdrawn, contract quantities pertaining to portion of work withdrawn shall be considered as 'Balance scope of work/supply' for calculating Risk & Cost amount.

- h.** Vendors are cautioned that, withdrawal after price bid opening or after contract signing or PO/LOI acceptance will be construed as tampering with BHEL's tender process. Suitable action for suspension of further business with the vendor may be taken as per BHEL corporate procedures.
- i.** Abridged version of extant 'Guidelines for suspension of business dealings with suppliers/ contractors' has now been uploaded on www.bhel.com on "supplier registration page" at the following link: http://www.bhel.com/vender_registration/vender.php (Guidelines for suspension of business dealings with suppliers/ contractors).

6. GENERAL CONDITIONS

- a.** The manner of finalization will be as mentioned in the "Confirmation to the Terms and Conditions" attached. Separate orders will be released for each project and documents should be supplied for each order separately.
- b.** BHEL reserves the right to reduce the tender quantity and to NOT to order for some or all material based on the changes in project.
- c.** BHEL shall have the right to visit vendor works during the execution of contract along with end customer for verifying status, inspection and testing of the material.
- d.** BHEL reserves the right to negotiate or re-float the tender in case the quoted prices are not acceptable.
- e.** Supplier shall arrange packing to avoid lose or damages during Road Transport, Site handling & Storage.
- f.** BHEL reserves the right to reject the offer of a particular bidder due to unsatisfactory past performance in the execution of a contract at any of BHEL projects / units.
- g.** The Drawings and Technical documents given in this enquiry are the sole property of BHEL. This should not be misused in any form.
- h.** Purchase Order, PO Item serial number, Material code, Quantity should be clearly marked on the packing
- i.** Confirmation for compliance is to be given in the offer for all the conditions specified above and to the respective Purchase Specification.
- j.** The bidder along with its associate/collaborators/sub-contractors/sub-vendors/consultants/service providers shall strictly adhere to BHEL fraud prevention policy (refer www.bhel.com) and shall immediately bring to the notice of the BHEL management about any fraud or suspected fraud as soon as it comes to their notice.
- k.** For this procurement, Public Procurement (Preference to Make in India), Order 2017 dated 15.06.2017 & 28.05.2018 and subsequent orders issued by the respective Nodal Ministry shall be applicable even if issued after issue of this NIT but before finalization of contract/PO/WO against this NIT. In the event of any Nodal Ministry prescribing higher or lower percentage of preference and/or local content in respect of this procurement, the same shall be applicable.

7. DOCUMENTATION:



BHARAT HEAVY ELECTRICALS LTD

VALVES PURCHASE

Trichy - 620 014, India

GENERAL TERMS AND CONDITIONS

Enquiry Reference: **RCPBNM2329**

- a. **With Consignment:** Duplicate for transporter copy, Original Invoice, Packing List, Delivery Challan, O&M manual (if applicable) Material Test Certificate, Test Certificates, Compliance Certificate, Guarantee/Warranty Certificate and other documents mentioned in PO/TDC/Drawing.
- b. **To Purchase:**
 - i. **FOR BHEL TRICHY case-** Original Invoice, Duplicate for transporter copy, Packing list, LWB and Delivery challan, GST declaration as mentioned in point 3c.
 - ii. **FOR Site case-** Original Invoice, Original LWB, Original Packing List, Original IBR documents, Original despatch clearance Certificate and Inspection report, Test certificates as per PO, Original Site Acknowledgment etc.
- c. **Identification:** Material code, Purchase Order, PO item serial number, Unique serial number if any should be provided in all despatch documents, materials and packing clearly.

8. **TENDER EVALUATION:**

a. **Techno-commercial Bid.**

- i. All vendors should submit General arrangement drawing, datasheet and C&I diagram (if any) of the offered product
- ii. Point by point technical confirmation of all pages of our technical specifications and commercial conditions are required with your sign and seal along with techno commercial offer.
- iii. Offers from supplier not having technical capability or not agreed for commercial terms, will be rejected.

b. **Price Bid.**

- i. Bidders qualified for part I will be intimated for participating in priced bid opening.
- ii. L1 bidder will be decided based on landed cost for the equipment to BHEL.

Indigenous Vendors

Total Landed cost/rate for each item = FOR Rate in INR (A) + Applicable Taxes (B) + Loading non-acceptance of commercial terms (C) – Applicable input tax credit (D)

A - Indigenous vendors submit offers on Free on Road (FOR), Stores, HPBP BHEL Trichy in INR.

B - Applicable GST and any other charges quoted by indigenous vendors will be added to the base price.

C - Loading for non-acceptance of payment terms, delivery schedule & liquidated damages (LD) will be added to the F.O.R. value for arriving the landed rate.

D - However, input tax credit shall be availed for GST, hence the same is excluded for arriving at the landed cost.

Foreign Vendors

Total Landed cost = CFR Rate in INR (A) + Applicable Duties (B) + Incidental Charges (C) + Loading for Container Shipment (D) + Loading for non-acceptance of commercial terms (E)

A - Foreign vendors to submit offers on CFR (Cost & Freight), Chennai port (LIFO – Liner In; Liner Out) basis per item wise in foreign currency, which will be converted to INR by multiplying with the Exchange rate (SBI TT Selling rate) as on the technical bid opening date. If the date of opening happens to be a bank holiday, then the forex rate as on previous bank (SBI) working day shall be taken.

B - Customs duty, Safe guard duty (as per the notification No 02/2014-Customs (SG) dated 13th August 2014) and antidumping duty (as per the notification No 18/2016-Customs (ADD) dated 17.05.2016) as if applicable will be added to the INR price.

C - Incidental charges will be added to the CFR Value. The incidental charge is inclusive of port handling charges, & freight charges for movement from Chennai port to BHEL, Trichy.

D - In case of shipment through containers, if 14 free days for Container detention is not provided in the offer, a loading of 22% on the freight rate per MT shall be considered by BHEL for arriving at the Total Landed Cost.

E - Loading for non-acceptance of payment terms, delivery schedule & Liquidated Damages (LD) will be added to the CFR value for arriving at the landed cost.

iii. In case of tie for the L1 positions,

- a. In the course of evaluation, if more than one bidder happens to occupy L1 status, effective L1 will be decided by soliciting discounts from respective L1 bidders.
- b. In case more than one bidder happens to occupy the L1 status even after soliciting discounts, the L1 bidder shall be decided by a toss/draw of lots, in the presence of the respective L1 bidders(s) or their representative(s).
- c. Ranking will be done accordingly, BHEL's decision in such situation shall be final and binding.



Maharatna Company

BHARAT HEAVY ELECTRICALS LTD

VALVES PURCHASE

Trichy - 620 014, India

GENERAL TERMS AND CONDITIONS

Enquiry Reference: **RCPBNM2329**

Note:

All clarifications / issues shall be addressed directly to the tender issuing (procurement) department's officials whose contact details are provided below

(1)

S Suresh

Deputy Manager

Valves Purchase

24 Building, 3rd Floor,

BHEL, Trichy-620014

+91 431 2578668

suresh.s@bhel.in

(2)

Ajay Kumar Gupta

AGM

Valves Purchase

24 Building, 3rd Floor,

BHEL, Trichy-620014

+91 431 2578156

ajaykumar.gupta@bhel.in

Declaration

In line with Government Public Procurement Order No. P-45021/2/2017-PP (BE-II) dated 28.05.2018, we hereby certify that we, (supplier name) are local supplier meeting requirement of minimum local content (---%) defined in as above orders for the following Enquiry SI Nos of BHEL Enquiry No **RCPBNM2329**

- Mention Enquiry SI Nos –

Details of location at which local value addition will be made is as follows:

.....

.....

By issuing this declaration, we understand and are in acceptance to the following-

- False declarations will be in breach of the Code of Integrity under Rule 175(1)(i)(h) of the General Financial Rules for which a bidder or its successors can be debarred for up to two years as per Rule 151 (iii) of the General Financial Rules along with such other actions as may be permissible under law.
- In case of debarment by any procuring entity for violation of the provisions of the Public Procurement (Preference to Make in India), Order 2017 we shall not be eligible for preference for procurement by any other procuring entity for the duration of the debarment. The debarment for such other procuring entities shall take effect prospectively from the date on which it comes to the notice of other procurement entities, the debarment takes effect prospectively from the date of uploading on the website(s) of The Department of Expenditure, GOI in such a manner that ongoing procurements are not disrupted.
- We undertake the onus of responsibility of submission of appropriately certified documents. We understand that BHEL is not at liability to verify the contents and will not be responsible for the declaration made by us. However, in case BHEL has any reason to doubt the authenticity of the local content, BHEL reserves the right to obtain the complete back up calculations before award of contract and we are liable to submit the same if requested by BHEL. We also understand that our bid is liable for rejection in case we fail to submit the details as requested by BHEL.

ALL DIMENSIONS ARE IN MILLIMETRES. FOR TOLERANCES OF UNTOLERANCED DIMENSIONS DURING MANUFACTURE REFER RELEVANT QCP / QP.

3-V-000-20825/2
DRAWING NO.

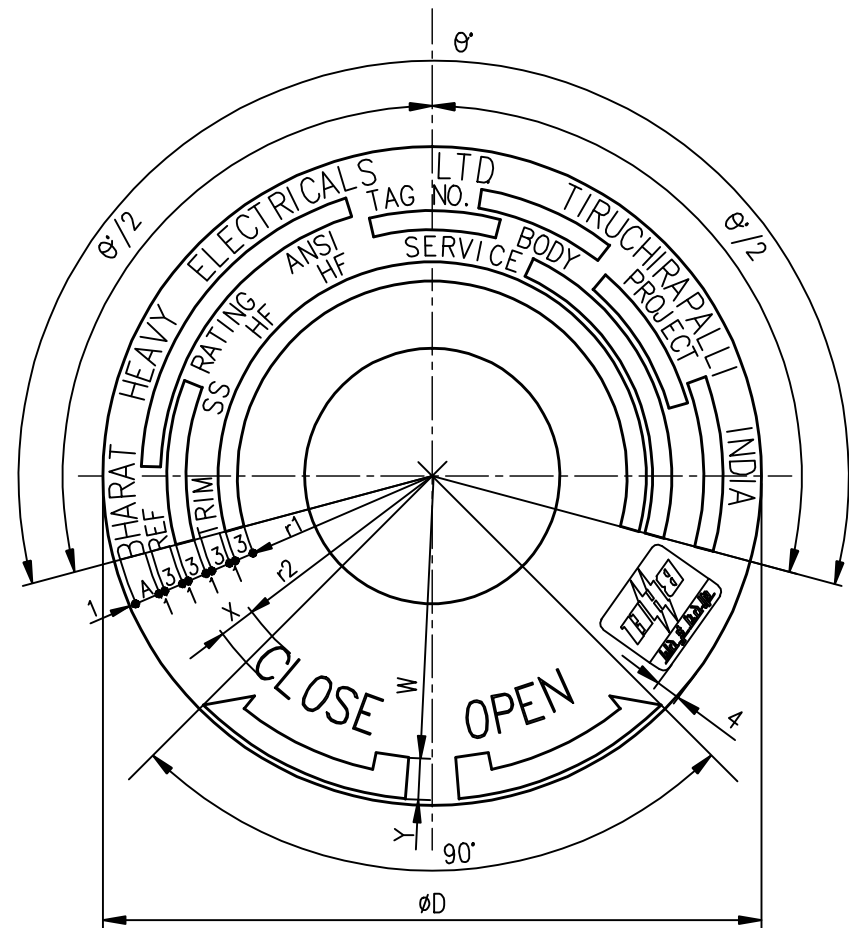

SL. NO.	DRAWING NO.	COMP. CODE	DIMENSIONS								MONOGRAM STD.	
			ϕD	ϕd	r1	r2	θ°	A	W	X		Y
01	3-V-G004-20825/1	964532990000	80	23	20	27	200	3	34	6	5	15-AA 040 11 20
02	3-V-G001-20825/1	964533000000	80	27	20	27	200	3	34	6	5	15-AA 040 11 20
03	3-V-W005-20825/1	964533010000	125	52	41.5	42.5	165	4	53.5	10	7	15-AA 040 11 20
04	3-V-W002-20825/1	964532970000	160	62.5	59	60	128	4	71	10	7	25-AA 040 11 20
05	3-V-W006-20825/1	964533020000	160	72.5	59	60	128	4	71	10	7	25-AA 040 11 20
06	3-V-W113-20825/1	964533030000	160	82.5	59	60	128	4	71	10	7	25-AA 040 11 20
07	3-V-W003-20825/1	964533040000	200	86	79	80	102	4	91	10	7	40-AA 040 11 20
08	3-V-W117-20825/1	964533050000	200	96	79	80	102	4	91	10	7	40-AA 040 11 20
09	3-V-W004-20825/1	964533060000	200	102.5	79	80	102	4	91	10	7	40-AA 040 11 20
10	3-V-W345-20825/2	964532980000	120	50	39	40	172	4	51	10	7	15-AA 040 11 20
11	3-V-R009-20825/2	964533070000	125	58	41.5	42.5	165	4	53.5	10	7	15-AA 040 11 20
12	3-V-W065-20825/2	964533080000	145	70	51.5	52.5	143	4	63.5	10	7	25-AA 040 11 20
13	3-V-R033-20825/2	964533090000	170	90	64	65	122	4	76	10	7	25-AA 040 11 20

NOTES:

01. MATERIAL: 18-8 Cr. Ni STAINLESS STEEL.
02. THE NAME PLATE SHALL HAVE RAISED BRIGHT POLISHED LETTERS, EMBLEM ETC., ON ETCHED BLACK ENAMELLED BACKGROUND.
03. THE ENAMEL SHALL BE CRACK RESISTING SO THAT WHEN BENT THE ENAMEL DOES NOT CRACK.
04. MONOGRAM SHALL BE BASED ON CORPORATE STANDARD No. AA 040 11 20 REV.1
05. FINAL THICKNESS OF THE NAME PLATE AFTER ETCHING, ENAMELLING & POLISHING SHALL NOT BE LESS THAN 0.5mm. SUPPLIERS SHALL TAKE SUITABLE RAW MATERIAL THICKNESS TO MEET THE SPECIFIED FINAL THICKNESS.
06. THIN LINES SHOWN ARE FOR SPACING PURPOSE ONLY AND SHOULD NOT BE PRINTED.

REDRAWN WITH REV.1 ON 12.04.08

REV	DATE	ALTERED	GANESH	REV	DATE	ALTERED	VB
2	08.08.11	CHD & APPD	GANESH&KRS	1	12.04.08	CHD & APPD	KRS&MRK
		MONOGRAM STANDARD HAS BEEN CHANGED FOR SL No.-10,11,12 & 13 DCP: 801209				DRAWING CONVERTED INTO SOFT COPY DCP No.800813	

CAUTION: The information on this document is the property of BHARAT HEAVY ELECTRICALS LTD. It must not be used directly or indirectly in any way detrimental to the interest of the company.

NO OFF	DESCRIPTION	MATL CODE	MATL SPECN	HEAT TREATMENT	SCRAP SORT	NET WT (kg)	GROSS WT (kg)	DRAWING No	ITEM No
	TYPE OF PRODUCT OR NAME OF CUSTOMER/PROJECT TA								
	BHARAT HEAVY ELECTRICALS LTD., UNIT: HIGH PRESSURE BOILER PLANT. TIRUCHIRAPALLI-620014. 365-121				DRN	V.SIVALINGAM	SIGN	DATE	NO.OF VAR.
					CHD	K.RAJASEKARAN		12.04.08	
					APPD	M.RAJAKUMAR		12.04.08	
	DEPT VL		SCALE	WEIGHT (KG).	REFERENCE INFORMATION				NO. OF ITEMS
	CODE 320		N.T.S						
	TITLE				CARD CODE	DRAWING NO.			REV
	CIRCULAR NAME PLATE				U 01	3-V-0000-20825			2

CAUTION: The information on this document is the property of BHARAT HEAVY ELECTRICALS LTD. It must not be used directly or indirectly in any way detrimental to the interest of the company.

FOR TOLERANCES OF UNTOLERANCED DIMENSIONS

ALL DIMENSIONS ARE IN MILLIMETRES.
DURING MANUFACTURE REFER RELEVANT QCP/QP

DCP No.	ALTERED	R.N	APPD	R.E
802041	CHD	P.A	DATE	24.11.'15
REV	API 6A, ISO 10423 REMOVED. NEW PUNCHING LINE ADDED.			
04				
ZONE	REVISED AND REDRAWN IN CAD			
04				

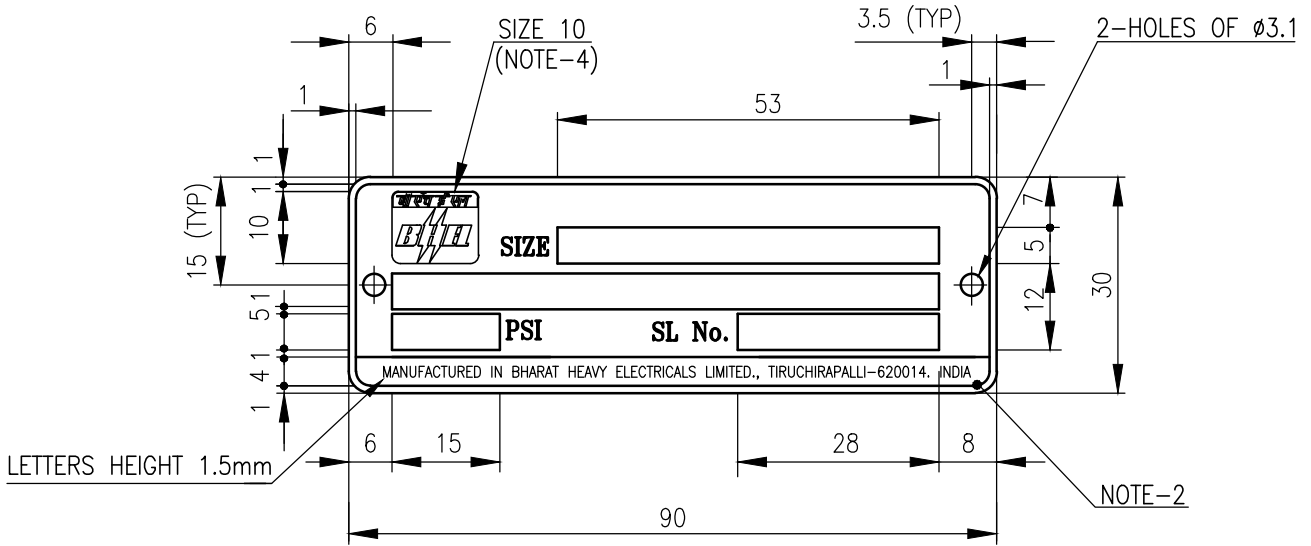

NOTES:-

1. UNLESS OTHERWISE SPECIFIED, ALL LETTER HEIGHTS TO BE SUITABLY SELECTED.
2. UNLESS OTHERWISE SPECIFIED FIGURES, SPACES AND BORDERS ARE TO BE RAISED AND BUFFED ON A BLACK BACK GROUND.
3. THE PLATING SHALL BE CRACK RESISTING SO THAT WHEN BENT, THE PLATING DOES NOT CRACK.
4. THE EMBLEM SHALL BE BASED ON CORP. STD. MONOGRAM 10-AA0401120 LATEST REVISION
5. ALL CHARACTERS WITHIN THIS BORDER LINE ARE TO BE BRIGHT ON A BLACK BACKGROUND.

		22 073 599	18-8 ST.STEEL 1mm THICKNESS			0.022			
NO OFF	DESCRIPTION	MATL CODE	MATL SPECN	HEAT TREATMENT	SCRAP SORT	NET WT (kg)	GROSS WT (kg)	DRAWING No	ITEM No
 365-122	BHARAT HEAVY ELECTRICALS LTD., UNIT: HIGH PRESSURE BOILER PLANT. TIRUCHIRAPALLI 620014.	DRN	NAME		SIGN		DATE	NO. OF VAR	
		CHD	T.RAJARAMAN				14-3-07		
		APPD	R.ELAYARAJA		<i>R.elayaraja</i>		14-3-07		
DEPT VL		SCALE	WEIGHT (KG).	REFERENCE INFORMATIONS				NO. OF ITEMS	
CODE 340		N.T.S	—	TUBING ADAPTER, X'MAS TREE CAP & STUDDERED TEE OF X'MAS TREE ASSY.					
TITLE				CARD CODE	DRAWING NO.				REV
NAME PLATE (FOR XMT ASSEMBLIES)				U 01	4-V-4015-07075				04

CAUTION: The information on this document is the property of BHARAT HEAVY ELECTRICALS LTD. It must not be used directly or indirectly in any way detrimental to the interest of the company.

FOR TOLERANCES OF UNTOLERANCED DIMENSIONS

ALL DIMENSIONS ARE IN MILLIMETRES.
DURING MANUFACTURE REFER RELEVANT QCP/QP

REV	DATE	ALTERED : D.LOGESH KUMAR
05	08.10.19	CHD & APPD : ARUNKUMAR P

"ISO 10423" REMOVED.
"API-6A" LOCATION CHANGED.

DCP No. 802485

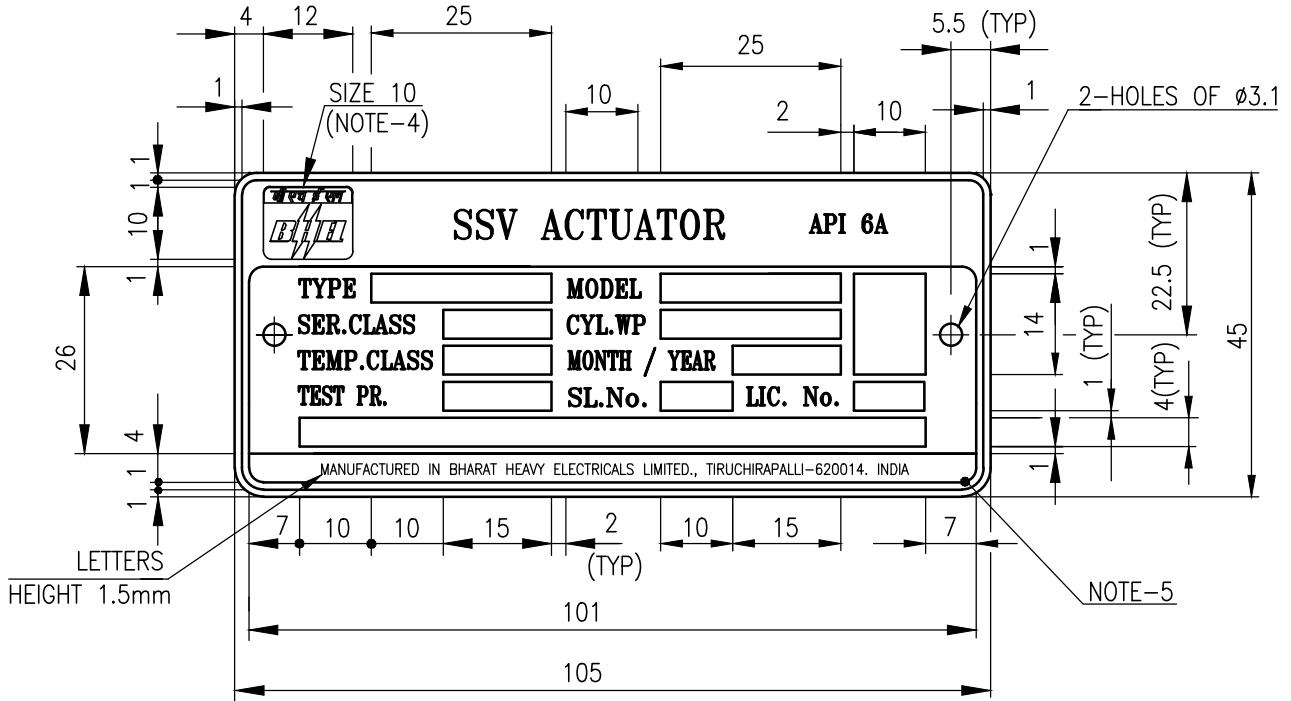

NOTES :-

1. UNLESS OTHERWISE SPECIFIED, ALL LETTER HEIGHTS TO BE SUITABLY SELECTED.
2. UNLESS OTHERWISE SPECIFIED FIGURES, SPACES AND BORDERS ARE TO BE RAISED AND BUFFED ON A BLACK BACK GROUND.
3. THE PLATING SHALL BE CRACK RESISTING SO THAT WHEN BENT, THE PLATING DOES NOT CRACK.
4. THE EMBLEM SHALL BE BASED ON CORP. STD. MONOGRAM 10-AA0401120 LATEST REVISION
5. ALL CHARACTERS WITHIN THIS BORDER LINE ARE TO BE BRIGHT ON A BLACK BACKGROUND.

		964643780000	18-8 ST. STEEL 1mm THICKNESS			0.037			035
NO OFF	DESCRIPTION	MATL CODE	MATL SPECN	HEAT TREATMENT	SCRAP SORT	NET WT (kg)	GROSS WT (kg)	DRAWING No	ITEM No
		BHARAT HEAVY ELECTRICALS LTD., UNIT: HIGH PRESSURE BOILER PLANT. TIRUCHIRAPALLI 620014.			DRN	NAME	SIGN	DATE	NO. OF VAR
365-122					CHD	T. RAJARAMAN	<i>T. Rajaraman</i>	10-8-05	—
					APPD	V. ALAGARSWAMI	<i>V. AlagarSwami</i>	10-8-05	—
DEPT VL	CODE	340	SCALE	NTS	WEIGHT (KG).	REFERENCE INFORMATIONS			NO. OF ITEMS
TITLE					CARD CODE	DRAWING NO.			REV
NAME PLATE (FOR 6A SSV ACTUATOR)					U 01	4-V-4751-07872			05

FOR TOLERANCES OF UNTOLERANCED DIMENSIONS

ALL DIMENSIONS ARE IN MILLIMETRES.
DURING MANUFACTURE REFER RELEVANT QCP/QP

REV	DATE	ALTERED : D.LOGESH KUMAR
05	08.10.19	CHD & APPD : ARUNKUMAR P

"ISO 10423" REMOVED.
"API-6A" LOCATION CHANGED.

DCP No. 802485

CAUTION: The information on this document is the property of BHARAT HEAVY ELECTRICALS LTD. It must not be used directly or indirectly in any way detrimental to the interest of the company.

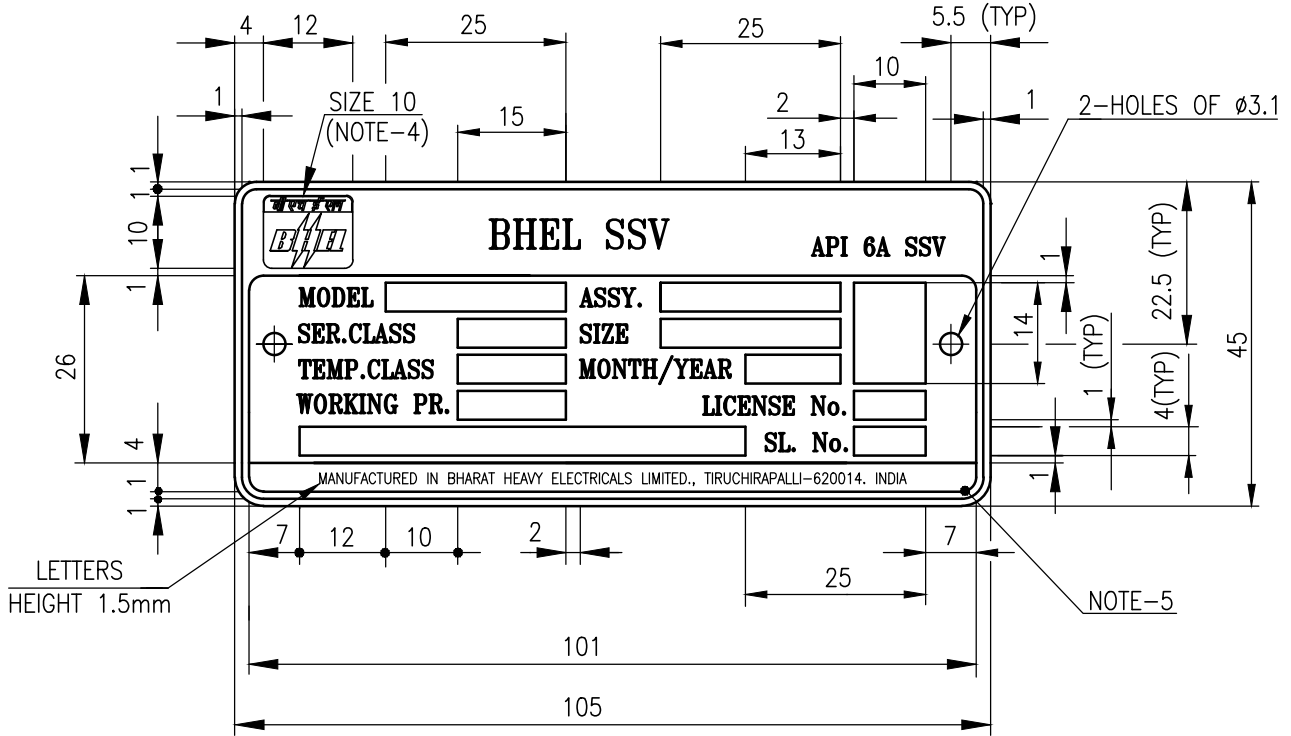

NOTES :-

1. UNLESS OTHERWISE SPECIFIED, ALL LETTER HEIGHTS TO BE SUITABLY SELECTED.
2. UNLESS OTHERWISE SPECIFIED FIGURES, SPACES AND BORDERS ARE TO BE RAISED AND BUFFED ON A BLACK BACK GROUND.
3. THE PLATING SHALL BE CRACK RESISTING SO THAT WHEN BENT, THE PLATING DOES NOT CRACK.
4. THE EMBLEM SHALL BE BASED ON CORP. STD. MONOGRAM 10-AA0401120 LATEST REVISION
5. ALL CHARACTERS WITHIN THIS BORDER LINE ARE TO BE BRIGHT ON A BLACK BACKGROUND.

		964643770000	18-8 ST. STEEL 1mm THICKNESS			0.037			035	
NO OFF	DESCRIPTION	MATL CODE	MATL SPECN	HEAT TREATMENT	SCRAP SORT	NET WT (kg)	GROSS WT (kg)	DRAWING No	ITEM No	
		BHARAT HEAVY ELECTRICALS LTD., UNIT: HIGH PRESSURE BOILER PLANT. TIRUCHIRAPALLI 620014.			DRN	T. RAJARAMAN		DATE	10-8-05	NO. OF VAR
365-122					CHD	T. RAJARAMAN		DATE	10-8-05	—
					APPD	V. ALAGARSWAMI		DATE	10-8-05	—
DEPT VL		SCALE	WEIGHT (KG).	REFERENCE INFORMATIONS				NO. OF ITEMS		
CODE	340	NTS						—		
TITLE				CARD CODE	DRAWING NO.				REV	
NAME PLATE (FOR 6A SSV VALVE)				U 01	4-V-4762-07871				05	

FOR TOLERANCES OF UNTOLERANCED DIMENSIONS

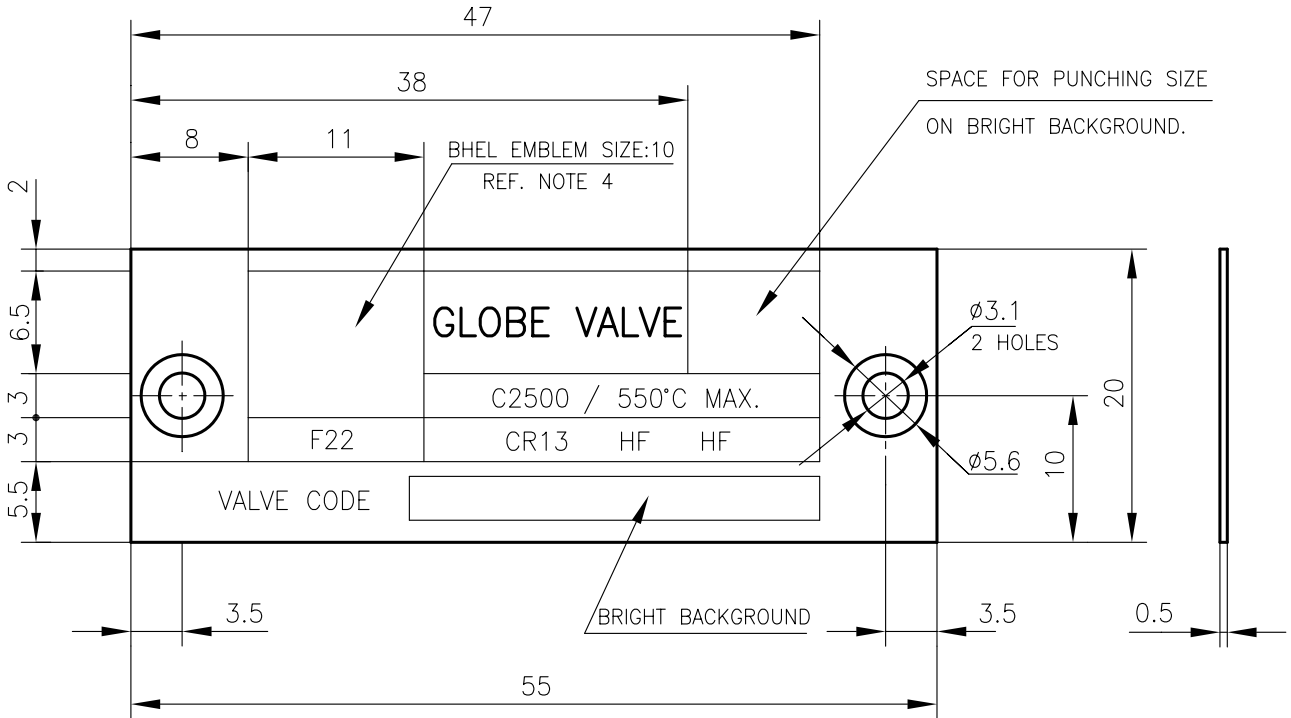

ALL DIMENSIONS ARE IN MILLIMETRES.
DURING MANUFACTURE REFER RELEVANT QCP/QP

REV 03	DATE 31.03.08	ALTERED M.SRINIVASAN CHD & APPD P.Boomnathan
DCP:800814 DRAWING CONVERTED INTO AUTOCAD.		

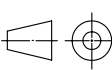

NOTES :-

1. MATERIAL : 18-8 Cr. Ni. STAINLESS STEEL.
2. THE NAME PLATE SHALL HAVE RAISED BRIGHT POLISHED LETTERS, MONOGRAM, ETC. ON ETCHED BLACK ENAMELLED BACKGROUND.
3. THE ENAMEL SHALL BE CRACK RESISTING SO THAT WHEN BENT THE ENAMEL DOES NOT CRACK.
4. MONOGRAM SHALL BE BASED ON CORPORATE STANDARED No. AA 040 11 20 (LATEST REV.)
5. FINAL THICKNESS OF THE NAME PLATE AFTER ETCHING, ENAMELLING & POLISHING SHALL NOT BE LESS THAN 0.5mm. SUPPLIERS SHALL TAKE SUITABLE RAW MATERIAL THICKNESS TO MEET THE SPECIFIED FINAL THICKNESS.

-	-	-	-	-	-	-	-	-	-
NO OFF	DESCRIPTION	MATL CODE	MATL SPECN	HEAT TREATMENT	SCRAP SORT	NET WT (kg)	GROSS WT (kg)	DRAWING No	ITEM No
 365-122	BHARAT HEAVY ELECTRICALS LTD., UNIT: HIGH PRESSURE BOILER PLANT. TIRUCHIRAPALLI 620014.		SCALE N T S	WEIGHT (KG). 0.003	DRN	NAME P.JAYARAMAN	SIGN	DATE 12.04.89	NO.OF VAR
					CHD	M.SRINIVASAN		12.04.89	
					APPD	N.NAGARAJAN		12.04.89	
DEPT VL		REFERENCE INFORMATIONS COMP. CODE: 96 452 989 0000 CAD:F406503	NO. OF ITEMS	TITLE NAME PLATE					
CODE 320				CARD CODE U 01	DRAWING NO. 4-V-5205-06503			REV 03	

CAUTION: The information on this document is the property of BHARAT HEAVY ELECTRICALS LTD. It must not be used directly or indirectly in any way detrimental to the interest of the company.

FOR TOLERANCES OF UNTOLERANCED DIMENSIONS

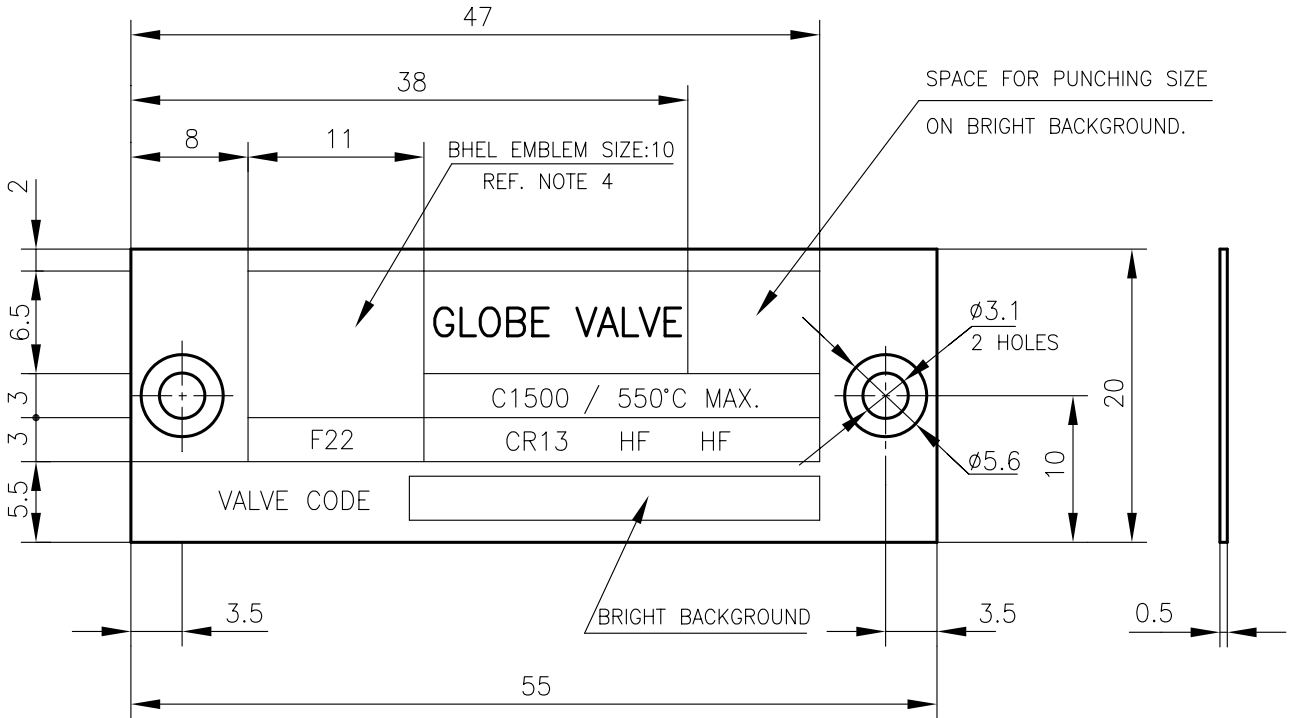

ALL DIMENSIONS ARE IN MILLIMETRES.
DURING MANUFACTURE REFER RELEVANT QCP/QP

REV 03	DATE 31.03.08	ALTERED M.SRINIVASAN
		CHD & APPD P.BOOMINATHAN
DCP:800814		
DRAWING CONVERTED INTO AUTOCAD.		



NOTES :-

1. MATERIAL : 18-8 Cr. Ni. STAINLESS STEEL.
2. THE NAME PLATE SHALL HAVE RAISED BRIGHT POLISHED LETTERS, MONOGRAM, ETC. ON ETCHED BLACK ENAMELLED BACKGROUND.
3. THE ENAMEL SHALL BE CRACK RESISTING SO THAT WHEN BENT THE ENAMEL DOES NOT CRACK.
4. MONOGRAM SHALL BE BASED ON CORPORATE STANDARED No. AA 040 11 20 (LATEST REV.)
5. FINAL THICKNESS OF THE NAME PLATE AFTER ETCHING, ENAMELLING & POLISHING SHALL NOT BE LESS THAN 0.5mm. SUPPLIERS SHALL TAKE SUITABLE RAW MATERIAL THICKNESS TO MEET THE SPECIFIED FINAL THICKNESS.

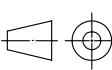
-	-	-	-	-	-	-	-	-	-
NO OFF	DESCRIPTION	MATL CODE	MATL SPECN	HEAT TREATMENT	SCRAP SORT	NET WT (kg)	GROSS WT (kg)	DRAWING No	ITEM No
 365-122	BHARAT HEAVY ELECTRICALS LTD., UNIT: HIGH PRESSURE BOILER PLANT. TIRUCHIRAPALLI 620014.	DRN		NAME P.JAYARAMAN		SIGN		DATE 12.04.89	NO.OF VAR
		CHD		M.SRINIVASAN				12.04.89	
		APPD		N.NAGARAJAN				12.04.89	
DEPT VL			SCALE	WEIGHT (KG).	REFERENCE INFORMATIONS				NO. OF ITEMS
CODE 320			N T S	0.003	COMP.CODE: 96 452 987 0000 CAD:F406462				
TITLE NAME PLATE					CARD CODE U 01	DRAWING NO. 4-V-5740-06462			REV 03

CAUTION: The information on this document is the property of BHARAT HEAVY ELECTRICALS LTD. It must not be used directly or indirectly in any way detrimental to the interest of the company.

FOR TOLERANCES OF UNTOLERANCED DIMENSIONS

ALL DIMENSIONS ARE IN MILLIMETRES.
DURING MANUFACTURE REFER RELEVANT QCP/QP

REV	DATE	ALTERED
		CHD & APPD

CAUTION: The information on this document is the property of BHARAT HEAVY ELECTRICALS LTD. It must not be used directly or indirectly in any way detrimental to the interest of the company.

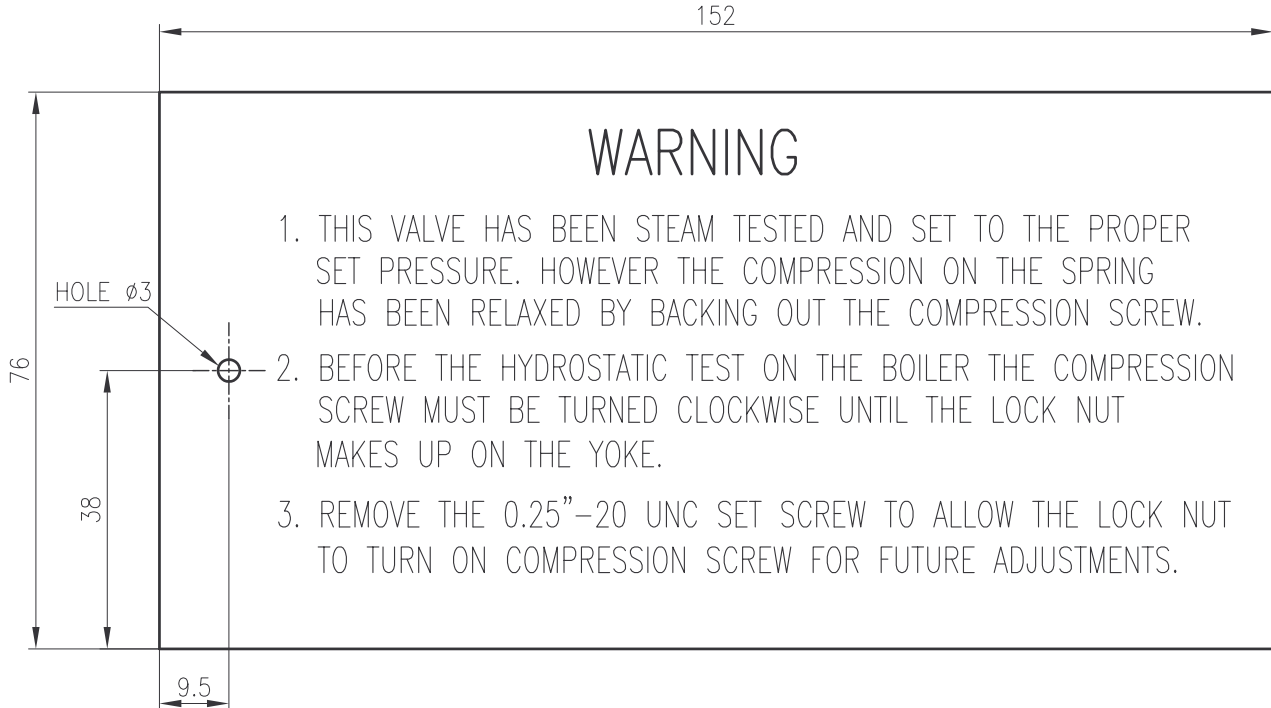

NOTES:

1. INSTRUCTIONS SHOULD BE PRINTED BOTH SIDES IN RED COLOUR WITH WHITE BACK GROUND.
2. ATTACHED TAG FOR HYDROSTATIC PLUG REMOVAL.

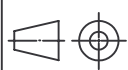
-	0.63X76X152	96416125	IS 513 CR2	-	10	0.06	-	-	201	
NO OFF	DESCRIPTION	MATL CODE	MATL SPECN	HEAT TREATMENT	SCRAP SORT	NET WT (kg)	GROSS WT (kg)	DRAWING No	ITEM No	
 BHARAT HEAVY ELECTRICALS LTD., UNIT: HIGH PRESSURE BOILER PLANT. TIRUCHIRAPALLI 620014.					DRN	NAME		SIGN	DATE	NO. OF VAR
					CHD	A.Sathish			02.02.11	
					APPD	S.MADHULINGAM			02.02.11	
						E.Athiannavi			02.02.11	
DEPT VL			SCALE	WEIGHT (KG).	REFERENCE INFORMATIONS				NO. OF ITEMS	
CODE 340			N T S	-	SL. NO: 2845					
TITLE					CARD CODE	DRAWING NO.			REV	
WARNING TAG					U 01	4-V-7301-10594			00	

CAUTION: The information on this document is the property of BHARAT HEAVY ELECTRICALS LTD. It must not be used directly or indirectly in any way detrimental to the interest of the company.

FOR TOLERANCES OF UNTOLERANCED DIMENSIONS

ALL DIMENSIONS ARE IN MILLIMETRES.
DURING MANUFACTURE REFER RELEVANT QCP/QP

REV 02	DATE 30.03.87	ALTERED CHD & APPD	K.P.L K.N	REV 03	DATE 11.09.12	ALTERED CHD & APPD	P.J E.A
EMBLEM SIZE ALTERED.				MANUFACTURING LOCATION CHANGED. DCN.No.SV.801388			

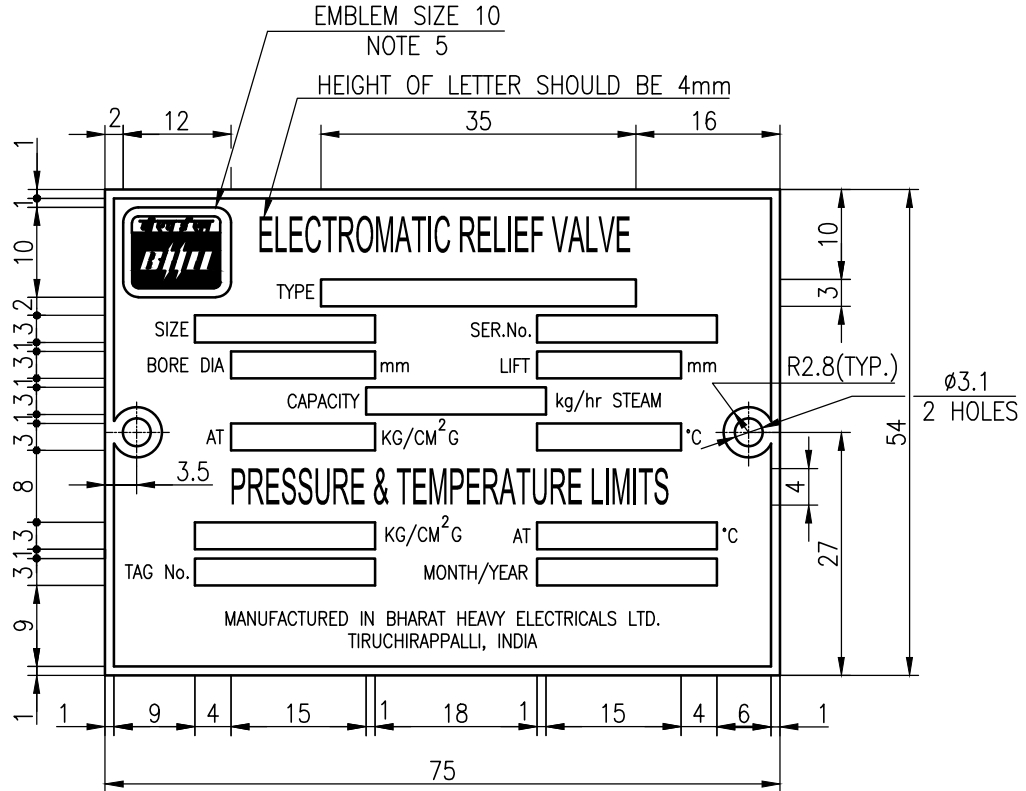

NOTES:

1. MATERIAL:ALUMINIUM t=0.56mm(0.022")
2. UNLESS OTHERWISE SPECIFIED ALL LETTER HEIGHTS TO BE 1.5mm.
3. UNLESS OTHERWISE SPECIFIED FIGURES, SPACES, AND BORDER TO BE RAISED AND BUFFED ON A BLACK BACKGROUND.
4. THE PLATING SHALL BE CRACK RESISTING SO THAT WHEN BENT,THE PLATING DOES NOT CRACK.
5. INTRODUCE LATEST BHEL EMBLEM HERE. THE EMBLEM SHALL BE BASED ON CORP. STD. MONOGRAM 10-AA 0401120 REV.01

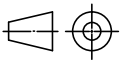
-	-	22073608	-	-	-	-	-	-	-
NO OFF	DESCRIPTION	MATL CODE	MATL SPECN	HEAT TREATMENT	SCRAP SORT	NET WT (kg)	GROSS WT (kg)	DRAWING No	ITEM No
		BHARAT HEAVY ELECTRICALS LTD., UNIT: HIGH PRESSURE BOILER PLANT. TIRUCHIRAPALLI 620014.			DRN	NAME T.R	SIGN	DATE	NO.OF VAR
365-122					CHD	V.R		24.01.79	
					APPD	J.A		24.01.79	
DEPT VL			SCALE	WEIGHT (KG).	REFERENCE DRG.NO.				ITEM No
CODE 340			NTS	0.06					451
TITLE					CARD CODE	DRAWING NO.			REV
NAME PLATE					U 01	4-V-7501-10004			03

CAUTION: The information on this document is the property of BHARAT HEAVY ELECTRICALS LTD. It must not be used directly or indirectly in any way detrimental to the interest of the company.

FOR TOLERANCES OF UNTOLERANCED DIMENSIONS

ALL DIMENSIONS ARE IN MILLIMETRES.
DURING MANUFACTURE REFER RELEVANT QCP/QP

REV 04	DATE 02.08.88	ALTERED CHD & APPD D.K	M.R.C	05	11.09.12	ALTERED CHD & APPD E.A	P.J
SIZE OF THE BHEL EMBLEM INDICATED.				MANUFACTURING LOCATION CHANGED. DCN.No.SV: 801388			

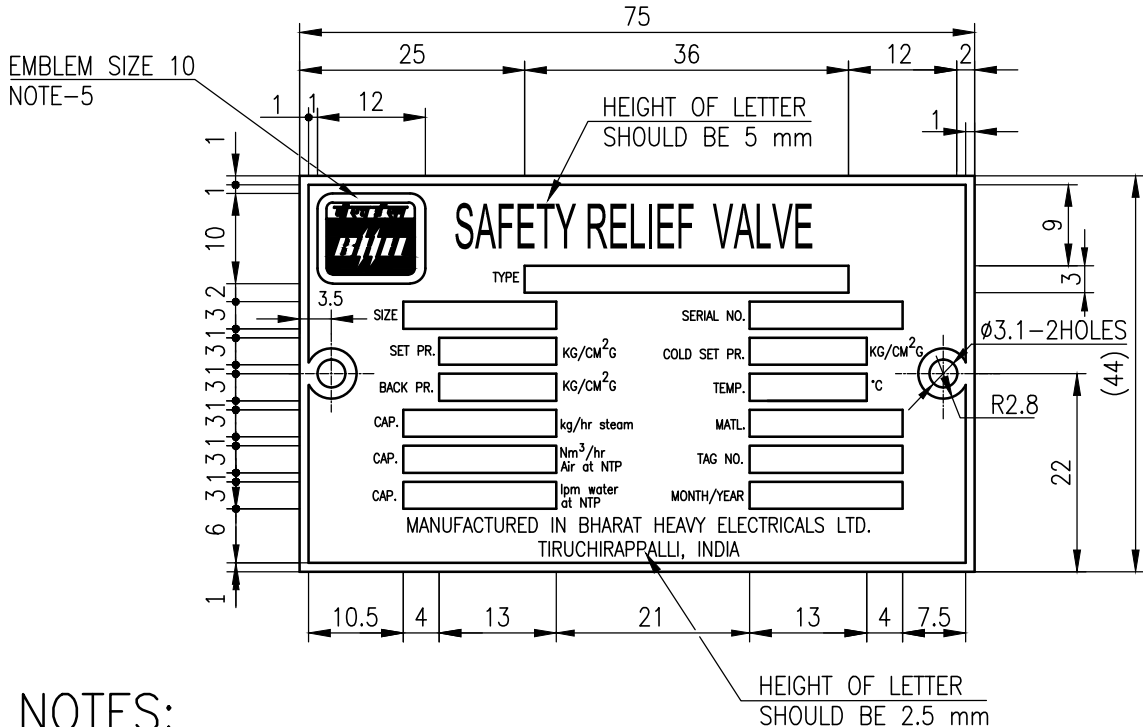

NOTES:

1. ALL CHARACTERS IN CROSS HATCHED AREA TO BE RAISED AND BUFFED ON A BLACK BACKGROUND.
2. ALL OTHER CHARACTERS TO BE BLACK ON A BLACK BACKGROUND.
3. THE EMBLEM SHALL BE BASED ON CORP.STD:- MONOGRAM 10-AA 0401120 REV.01
4. MATERIAL:-18 CHROME 8 NICKEL STAINLESS STEEL 0.5mm THICKNESS

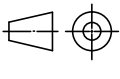
-	-	22073551	-	-	-	-	-	-	-
NO OFF	DESCRIPTION	MATL CODE	MATL SPECN	HEAT TREATMENT	SCRAP SORT	NET WT (kg)	GROSS WT (kg)	DRAWING No	ITEM No
 BHARAT HEAVY ELECTRICALS LTD., UNIT: HIGH PRESSURE BOILER PLANT. TIRUCHIRAPPALLI 620014. 365-122					DRN	NAME S.S	SIGN	DATE 27.01.79	NO.OF VAR
					CHD	K.B		29.01.79	
					APPD	D.K		31.01.79	
DEPT VL		 SCALE NTS	WEIGHT (KG). 0.008		REFERENCE INFORMATIONS				ITEM No. 194
CODE 340			TITLE NAME PLATE		CARD CODE U 01	DRAWING NO. 4-V-9000-13007			REV 05

CAUTION: The information on this document is the property of BHARAT HEAVY ELECTRICALS LTD. It must not be used directly or indirectly in any way detrimental to the interest of the company.

FOR TOLERANCES OF UNTOLERANCED DIMENSIONS

ALL DIMENSIONS ARE IN MILLIMETRES.
DURING MANUFACTURE REFER RELEVANT QCP/QP

REV	DATE	ALTERED
		CHD & APPD

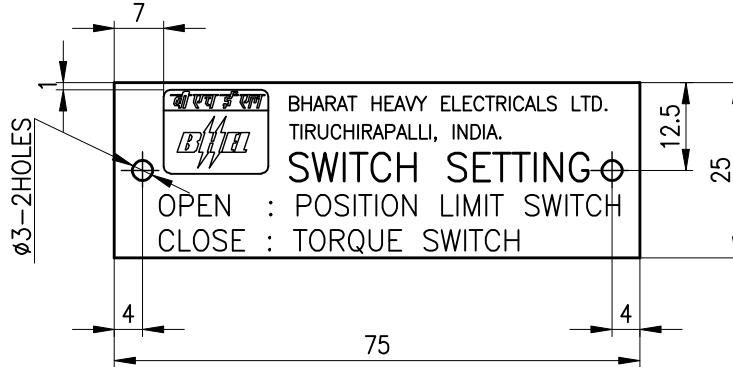

APPLICATION:

FOR ALL MOTOR OPERATED VALVES
EXCEPT 100mm & ABOVE 1500 CLASS AND ABOVE GATE VALVES

NOTES:

1. MATERIAL IS STAINLESS STEEL
2. THICKNESS OF THE PLATE 1mm
3. MONOGRAM SHALL BE BASED ON CORPORATE STANDARD No. AA0401120 REV.1
4. THE NAME PLATE SHALL BE CRACK RESISTING SO THAT WHEN BENT, THE PLATING DOES NOT CRACK
5. THE NAME PLATE SHALL HAVE RAISED BRIGHT WHITE LETTERS, EMBLEM ETC ON ETCHED BLACK BACKGROUND

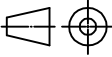
		96466063									
NO OFF	DESCRIPTION	MATL CODE	MATL SPECN	HEAT TREATMENT	SCRAP SORT	NET WT (kg)	GROSS WT (kg)	DRAWING No		ITEM No	
		BHARAT HEAVY ELECTRICALS LTD., UNIT: HIGH PRESSURE BOILER PLANT. TIRUCHIRAPALLI 620014.			DRN	NAME		SIGN	DATE	NO. OF VAR	
365-122					CHD	V. BAIRAVAN			08.10.10		
					APPD	S. SATHEES			08.10.10		
						K. RAJASEKARAN			08.10.10		
DEPT	VL	SCALE		WEIGHT (KG).		REFERENCE INFORMATION				NO. OF ITEMS	
CODE	320	 N.T.S									
TITLE					CARD CODE	DRAWING NO.				REV	
NAME PLATE (FOR CONVENTIONAL VALVES)					U 01	4-V-G004-19240					

CAUTION: The information on this document is the property of BHARAT HEAVY ELECTRICALS LTD. It must not be used directly or indirectly in any way detrimental to the interest of the company.

FOR TOLERANCES OF UNTOLERANCED DIMENSIONS

ALL DIMENSIONS ARE IN MILLIMETRES.
DURING MANUFACTURE REFER RELEVANT QCP/QP

REV	DATE	ALTERED
		CHD & APPD

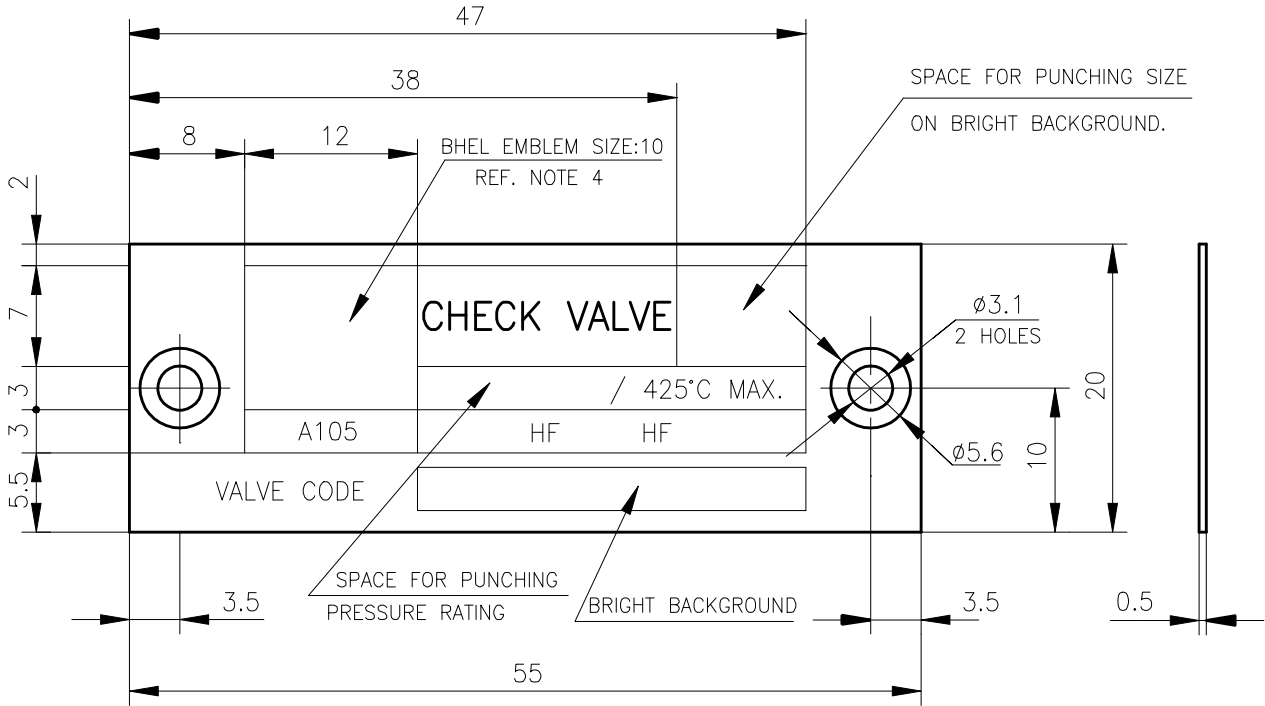

NOTES :-

- MATERIAL : 18-8 Cr. Ni. STAINLESS STEEL.
- THE NAME PLATE SHALL HAVE RAISED BRIGHT POLISHED LETTERS, MONOGRAM, ETC. ON ETCHED BLACK ENAMELLED BACKGROUND.
- THE ENAMEL SHALL BE CRACK RESISTING SO THAT WHEN BENT THE ENAMEL DOES NOT CRACK.
- MONOGRAM SHALL BE BASED ON CORPORATE STANDARD No. AA 040 11 20 (LATEST REV.)
- FINAL THICKNESS OF THE NAME PLATE AFTER ETCHING, ENAMELLING & POLISHING SHALL NOT BE LESS THAN 0.5mm. SUPPLIERS SHALL TAKE SUITABLE RAW MATERIAL THICKNESS TO MEET THE SPECIFIED FINAL THICKNESS.

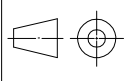
-	-	-	-	-	-	-	-	-	-
NO OFF	DESCRIPTION	MATL CODE	MATL SPECN	HEAT TREATMENT	SCRAP SORT	NET WT (kg)	GROSS WT (kg)	DRAWING No	ITEM No
	 BHARAT HEAVY ELECTRICALS LTD., UNIT: HIGH PRESSURE BOILER PLANT. TIRUCHIRAPALLI 620014. 365-122								
		DRN	S.KOMALA	SIGN	DATE	NO. OF VAR			
		CHD	GANESH BARLA		27.11.10				
		APPD	M.RAJAKUMAR		27.11.10				
DEPT VL		SCALE	WEIGHT (KG).	REFERENCE INFORMATION				NO. OF ITEMS	
CODE		N T S	0.003	COMP. CODE: 96 465 380 0000 CAD:F426933					
TITLE					CARD CODE	DRAWING NO.			REV
NAME PLATE					U 01	4-V-H456-26933			00

CAUTION: The information on this document is the property of BHARAT HEAVY ELECTRICALS LTD. It must not be used directly or indirectly in any way detrimental to the interest of the company.

FOR TOLERANCES OF UNTOLERANCED DIMENSIONS

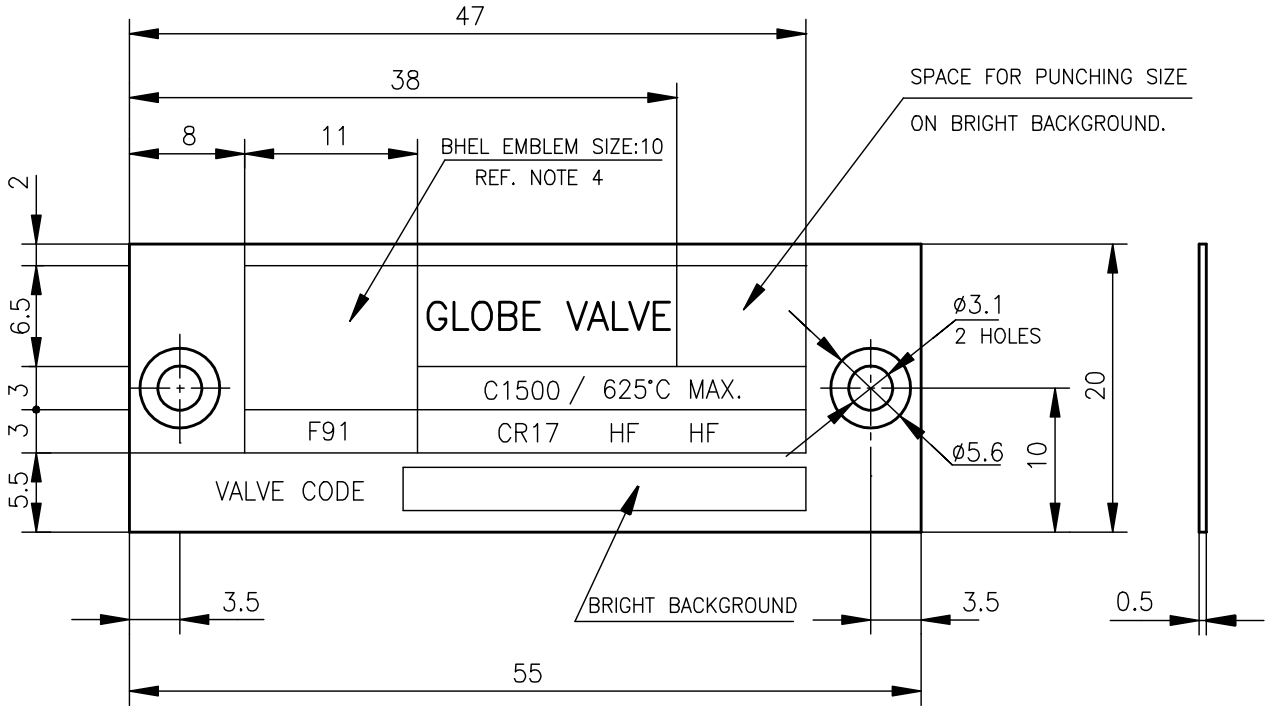

ALL DIMENSIONS ARE IN MILLIMETRES.
DURING MANUFACTURE REFER RELEVANT QCP/QP

REV	DATE	ALTERED
		CHD & APPD



NOTES :-

- MATERIAL : 18-8 Cr. Ni. STAINLESS STEEL.
- THE NAME PLATE SHALL HAVE RAISED BRIGHT POLISHED LETTERS, MONOGRAM, ETC. ON ETCHED BLACK ENAMELLED BACKGROUND.
- THE ENAMEL SHALL BE CRACK RESISTING SO THAT WHEN BENT THE ENAMEL DOES NOT CRACK.
- MONOGRAM SHALL BE BASED ON CORPORATE STANDARED No. AA 040 11 20 (LATEST REV.)
- FINAL THICKNESS OF THE NAME PLATE AFTER ETCHING, ENAMELLING & POLISHING SHALL NOT BE LESS THAN 0.5mm. SUPPLIERS SHALL TAKE SUITABLE RAW MATERIAL THICKNESS TO MEET THE SPECIFIED FINAL THICKNESS.

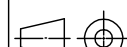
-	-	-	-	-	-	-	-	-	-
NO OFF	DESCRIPTION	MATL CODE	MATL SPECN	HEAT TREATMENT	SCRAP SORT	NET WT (kg)	GROSS WT (kg)	DRAWING No	ITEM No
	 BHARAT HEAVY ELECTRICALS LTD., UNIT: HIGH PRESSURE BOILER PLANT. TIRUCHIRAPALLI 620014. 365-122								
		DRN	NAME P.B.MAHES		SIGN		DATE 18.02.10	NO. OF VAR	
		CHD	M.SRINIVASAN				18.02.10		
	APPD	M.RAJAKUMAR				18.02.10			
DEPT VL			SCALE	WEIGHT (KG).	REFERENCE INFORMATION				NO. OF ITEMS
CODE 320			N T S	0.003	COMP. CODE: 96 465 355 0000 CAD: F426844				
TITLE				CARD CODE	DRAWING NO.				REV
NAME PLATE				U 01	4-V-H957-26844				00

CAUTION: The information on this document is the property of BHARAT HEAVY ELECTRICALS LTD. It must not be used directly or indirectly in any way detrimental to the interest of the company.

FOR TOLERANCES OF UNTOLERANCED DIMENSIONS

ALL DIMENSIONS ARE IN MILLIMETRES.
DURING MANUFACTURE REFER RELEVANT QCP/QP

REV	DATE	ALTERED
		CHD & APPD

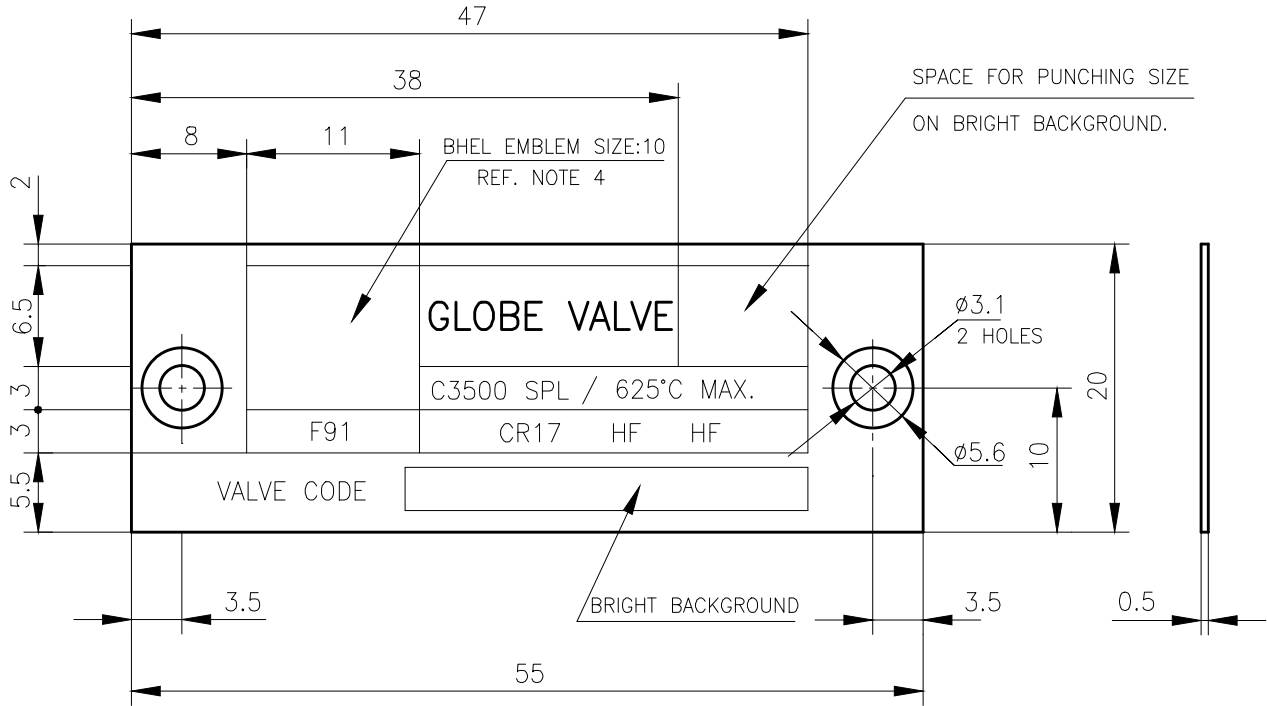

NOTES :-

- MATERIAL : 18-8 Cr. Ni. STAINLESS STEEL.
- THE NAME PLATE SHALL HAVE RAISED BRIGHT POLISHED LETTERS, MONOGRAM, ETC. ON ETCHED BLACK ENAMELLED BACKGROUND.
- THE ENAMEL SHALL BE CRACK RESISTING SO THAT WHEN BENT THE ENAMEL DOES NOT CRACK.
- MONOGRAM SHALL BE BASED ON CORPORATE STANDARED No. AA 040 11 20 (LATEST REV.)
- FINAL THICKNESS OF THE NAME PLATE AFTER ETCHING, ENAMELLING & POLISHING SHALL NOT BE LESS THAN 0.5mm. SUPPLIERS SHALL TAKE SUITABLE RAW MATERIAL THICKNESS TO MEET THE SPECIFIED FINAL THICKNESS.

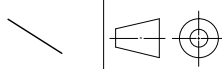
-	-	-	-	-	-	-	-	-	-
NO OFF	DESCRIPTION	MATL CODE	MATL SPECN	HEAT TREATMENT	SCRAP SORT	NET WT (kg)	GROSS WT (kg)	DRAWING No	ITEM No
	 BHARAT HEAVY ELECTRICALS LTD., UNIT: HIGH PRESSURE BOILER PLANT. TIRUCHIRAPALLI 620014. 365-122								
		DRN	GANESH	SIGN	DATE	NO. OF VAR			
		CHD	GANESH		08.12.12				
		APPD	K.RAJASEKARAN		08.12.12				
DEPT VL		SCALE	WEIGHT (KG).	REFERENCE INFORMATION				NO. OF ITEMS	
CODE 320		N T S	0.003	COMP. CODE: 96 465 499 0000 CAD:F427004					
TITLE					CARD CODE	DRAWING NO.			REV
NAME PLATE					U 01	4-V-H992-27004			00

CAUTION: The information on this document is the property of BHARAT HEAVY ELECTRICALS LTD. It must not be used directly or indirectly in any way detrimental to the interest of the company.

FOR TOLERANCES OF UNTOLERANCED DIMENSIONS

ALL DIMENSIONS ARE IN MILLIMETRES.
DURING MANUFACTURE REFER RELEVANT QCP/QP

REV	DATE	ALTERED
		CHD & APPD

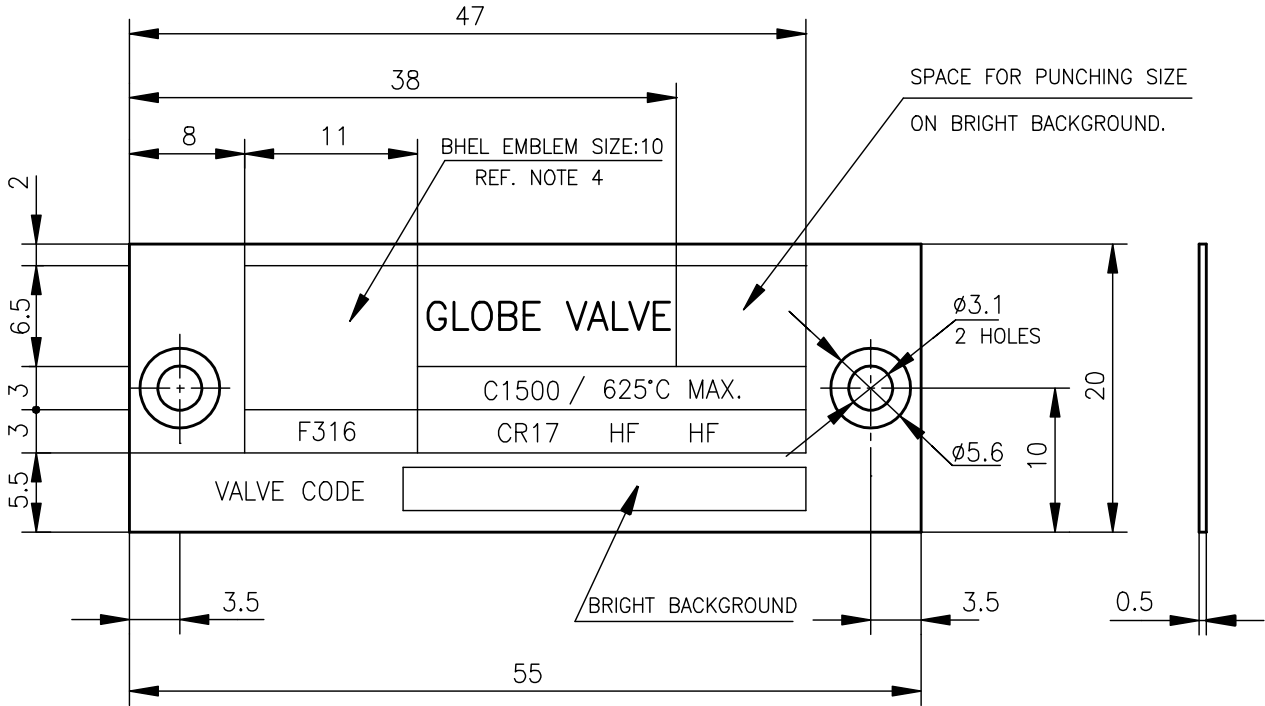

NOTES :-

- MATERIAL : 18-8 Cr. Ni. STAINLESS STEEL.
- THE NAME PLATE SHALL HAVE RAISED BRIGHT POLISHED LETTERS, MONOGRAM, ETC. ON ETCHED BLACK ENAMELLED BACKGROUND.
- THE ENAMEL SHALL BE CRACK RESISTING SO THAT WHEN BENT THE ENAMEL DOES NOT CRACK.
- MONOGRAM SHALL BE BASED ON CORPORATE STANDARED No. AA 040 11 20 (LATEST REV.)
- FINAL THICKNESS OF THE NAME PLATE AFTER ETCHING, ENAMELLING & POLISHING SHALL NOT BE LESS THAN 0.5mm. SUPPLIERS SHALL TAKE SUITABLE RAW MATERIAL THICKNESS TO MEET THE SPECIFIED FINAL THICKNESS.

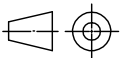
-	-	-	-	-	-	-	-	-	-
NO OFF	DESCRIPTION	MATL CODE	MATL SPECN	HEAT TREATMENT	SCRAP SORT	NET WT (kg)	GROSS WT (kg)	DRAWING No	ITEM No
	 BHARAT HEAVY ELECTRICALS LTD., UNIT: HIGH PRESSURE BOILER PLANT. TIRUCHIRAPALLI 620014. 365-122								
		DRN	NAME P.B.MAHES	SIGN	DATE 18.02.10	NO.OF VAR			
		CHD	M.SRINIVASAN		18.02.10				
		APPD	M.RAJAKUMAR		18.02.10				
DEPT VL		SCALE	WEIGHT (KG).	REFERENCE INFORMATION				NO. OF ITEMS	
CODE 320		N T S	0.003	COMP. CODE: 96 465 366 0000 CAD: F426849					
TITLE					CARD CODE	DRAWING NO.			REV
NAME PLATE					U 01	4-V-HA07-26849			00

CAUTION: The information on this document is the property of BHARAT HEAVY ELECTRICALS LTD. It must not be used directly or indirectly in any way detrimental to the interest of the company.

FOR TOLERANCES OF UNTOLERANCED DIMENSIONS

ALL DIMENSIONS ARE IN MILLIMETRES.
DURING MANUFACTURE REFER RELEVANT QCP/QP

REV	DATE	ALTERED
		CHD & APPD

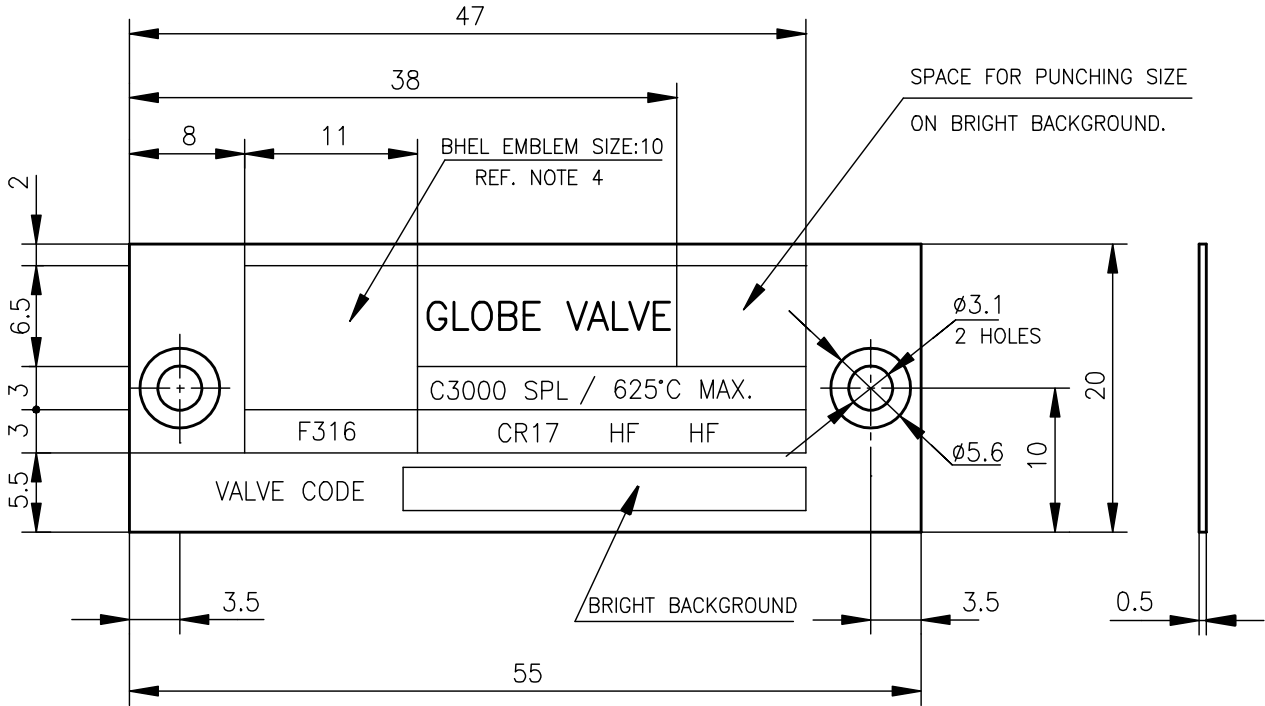

NOTES :-

1. MATERIAL : 18-8 Cr. Ni. STAINLESS STEEL.
2. THE NAME PLATE SHALL HAVE RAISED BRIGHT POLISHED LETTERS, MONOGRAM, ETC. ON ETCHED BLACK ENAMELLED BACKGROUND.
3. THE ENAMEL SHALL BE CRACK RESISTING SO THAT WHEN BENT THE ENAMEL DOES NOT CRACK.
4. MONOGRAM SHALL BE BASED ON CORPORATE STANDARED No. AA 040 11 20 (LATEST REV.)
5. FINAL THICKNESS OF THE NAME PLATE AFTER ETCHING, ENAMELLING & POLISHING SHALL NOT BE LESS THAN 0.5mm. SUPPLIERS SHALL TAKE SUITABLE RAW MATERIAL THICKNESS TO MEET THE SPECIFIED FINAL THICKNESS.

-	-	-	-	-	-	-	-	-	-
NO OFF	DESCRIPTION	MATL CODE	MATL SPECN	HEAT TREATMENT	SCRAP SORT	NET WT (kg)	GROSS WT (kg)	DRAWING No	ITEM No
	 BHARAT HEAVY ELECTRICALS LTD., UNIT: HIGH PRESSURE BOILER PLANT. TIRUCHIRAPALLI 620014. 365-122								
		DRN	NAME	SIGN	DATE	NO. OF VAR			
		CHD	P.B.MAHES		18.02.10				
		APPD	M.SRINIVASAN		18.02.10				
			M.RAJAKUMAR		18.02.10				
DEPT	VL	SCALE	WEIGHT (KG).	REFERENCE INFORMATION				NO. OF ITEMS	
CODE	320	N T S	0.003	COMP. CODE: 96 465 367 0000 CAD: F426850					
TITLE				CARD CODE	DRAWING NO.			REV	
NAME PLATE				U 01	4-V-HC07-26850			00	

CAUTION: The information on this document is the property of BHARAT HEAVY ELECTRICALS LTD. It must not be used directly or indirectly in any way detrimental to the interest of the company.

REV	DATE	ALTERED
		CHD & APPD

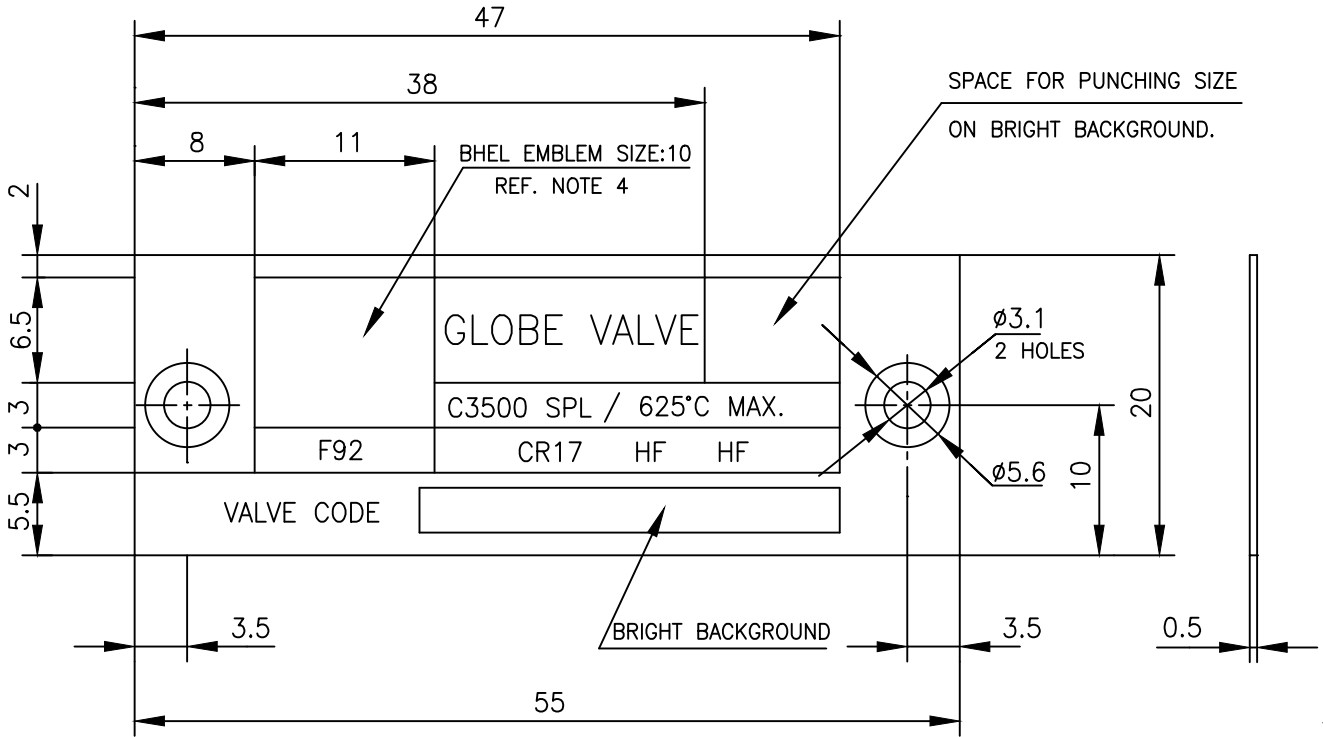

NOTES :-

- MATERIAL : 18-8 Cr. Ni. STAINLESS STEEL.
- THE NAME PLATE SHALL HAVE RAISED BRIGHT POLISHED LETTERS, MONOGRAM, ETC. ON ETCHED BLACK ENAMELLED BACKGROUND.
- THE ENAMEL SHALL BE CRACK RESISTING SO THAT WHEN BENT THE ENAMEL DOES NOT CRACK.
- MONOGRAM SHALL BE BASED ON CORPORATE STANDARED No. AA 040 11 20 (LATEST REV.)
- FINAL THICKNESS OF THE NAME PLATE AFTER ETCHING, ENAMELLING & POLISHING SHALL NOT BE LESS THAN 0.5mm. SUPPLIERS SHALL TAKE SUITABLE RAW MATERIAL THICKNESS TO MEET THE SPECIFIED FINAL THICKNESS.

-	-	-	-	-	-	-	-	-	-
NO OFF	DESCRIPTION	MATL CODE	MATL SPECN	HEAT TREATMENT	SCRAP SORT	NET WT (kg)	GROSS WT (kg)	DRAWING No	ITEM No



BHARAT HEAVY ELECTRICALS LTD.,
UNIT: HIGH PRESSURE BOILER PLANT.
TIRUCHIRAPALLI 620014.

DRN	S.MADHURAM	SIGN	DATE	NO. OF VAR
CHD	M.RANA PRATAP		19.02.18	
APPD	K.RAJASEKARAN		19.02.18	

DEPT VL	/	⊕	SCALE	WEIGHT (KG).	REFERENCE INFORMATIONS	NO. OF ITEMS
CODE 320			N T S	0.003	COMP. CODE: 96 600 055 0000 CAD: F426845	

TITLE	CARD CODE	DRAWING NO.	REV
NAME PLATE	U 01	4-V-SELQ-27349	00

CAUTION: The information on this document is the property of BHARAT HEAVY ELECTRICALS LTD. It must not be used directly or indirectly in any way detrimental to the interest of the company.

REV	DATE	ALTERED
		CHD & APPD

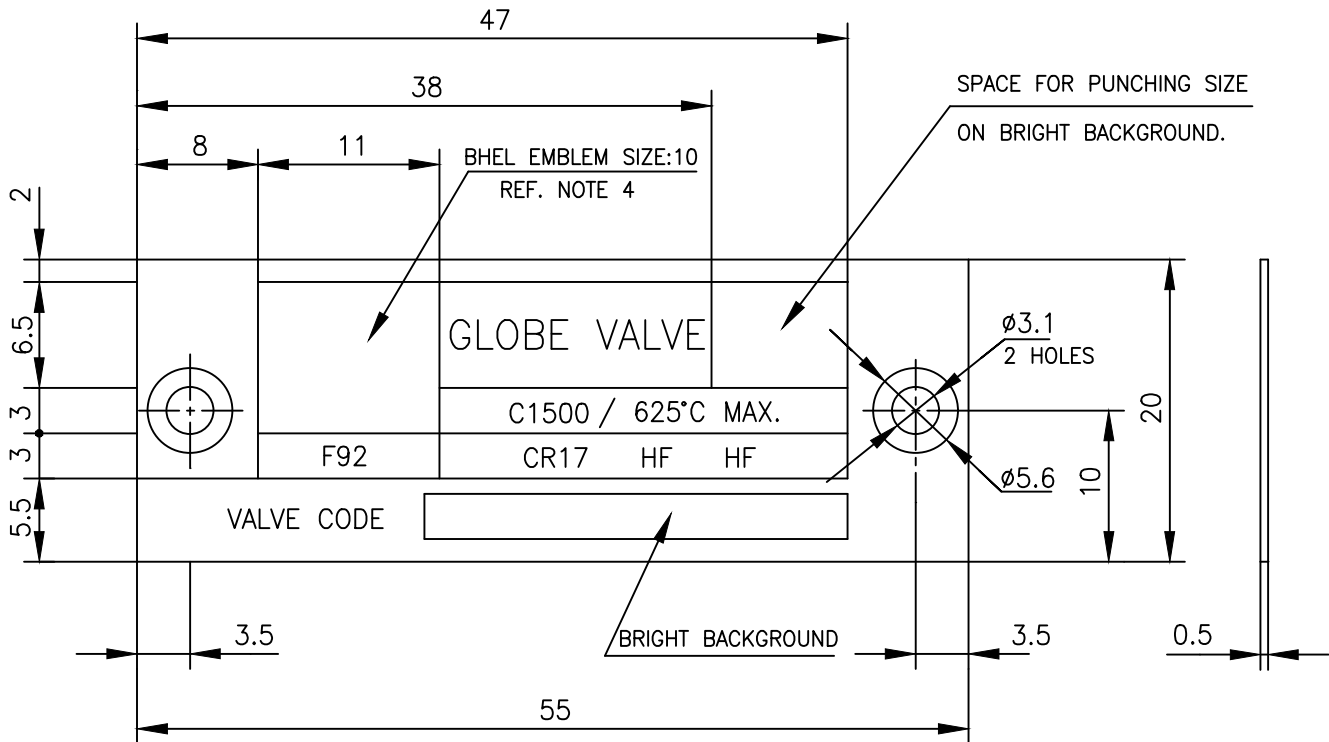

NOTES :-

1. MATERIAL : 18-8 Cr. Ni. STAINLESS STEEL.
2. THE NAME PLATE SHALL HAVE RAISED BRIGHT POLISHED LETTERS, MONOGRAM, ETC. ON ETCHED BLACK ENAMELLED BACKGROUND.
3. THE ENAMEL SHALL BE CRACK RESISTING SO THAT WHEN BENT THE ENAMEL DOES NOT CRACK.
4. MONOGRAM SHALL BE BASED ON CORPORATE STANDARED No. AA 040 11 20 (LATEST REV.)
5. FINAL THICKNESS OF THE NAME PLATE AFTER ETCHING, ENAMELLING & POLISHING SHALL NOT BE LESS THAN 0.5mm. SUPPLIERS SHALL TAKE SUITABLE RAW MATERIAL THICKNESS TO MEET THE SPECIFIED FINAL THICKNESS.

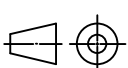
-	-	-	-	-	-	-	-	-	-	
NO OFF	DESCRIPTION	MATL CODE	MATL SPECN	HEAT TREATMENT	SCRAP SORT	NET WT (kg)	GROSS WT (kg)	DRAWING No	ITEM No	
 BHARAT HEAVY ELECTRICALS LTD., UNIT: HIGH PRESSURE BOILER PLANT. TIRUCHIRAPALLI 620014.					DRN	NAME S.Madhuram		SIGN	DATE 07.06.19	NO.OF VAR
					CHD	M.Ranapratap			07.06.19	
					APPD	K.Rajasekaran			07.06.19	
DEPT VL	/		SCALE	WEIGHT (KG).	REFERENCE INFORMATIONS				NO. OF ITEMS	
CODE 320			N T S	0.003	COMP. CODE: 96 600 067 0000 CAD: F426844					
TITLE NAME PLATE					CARD CODE U 01	DRAWING NO. 4-V-SFFQ-27448				REV 00

FOR TOLERANCES OF UNTOLERANCED DIMENSIONS

ALL DIMENSIONS ARE IN MILLIMETRES.
DURING MANUFACTURE REFER RELEVANT QCP/QP

REV	DATE	ALTERED
		CHD & APPD

CAUTION: The information on this document is the property of BHARAT HEAVY ELECTRICALS LTD. It must not be used directly or indirectly in any way detrimental to the interest of the company.

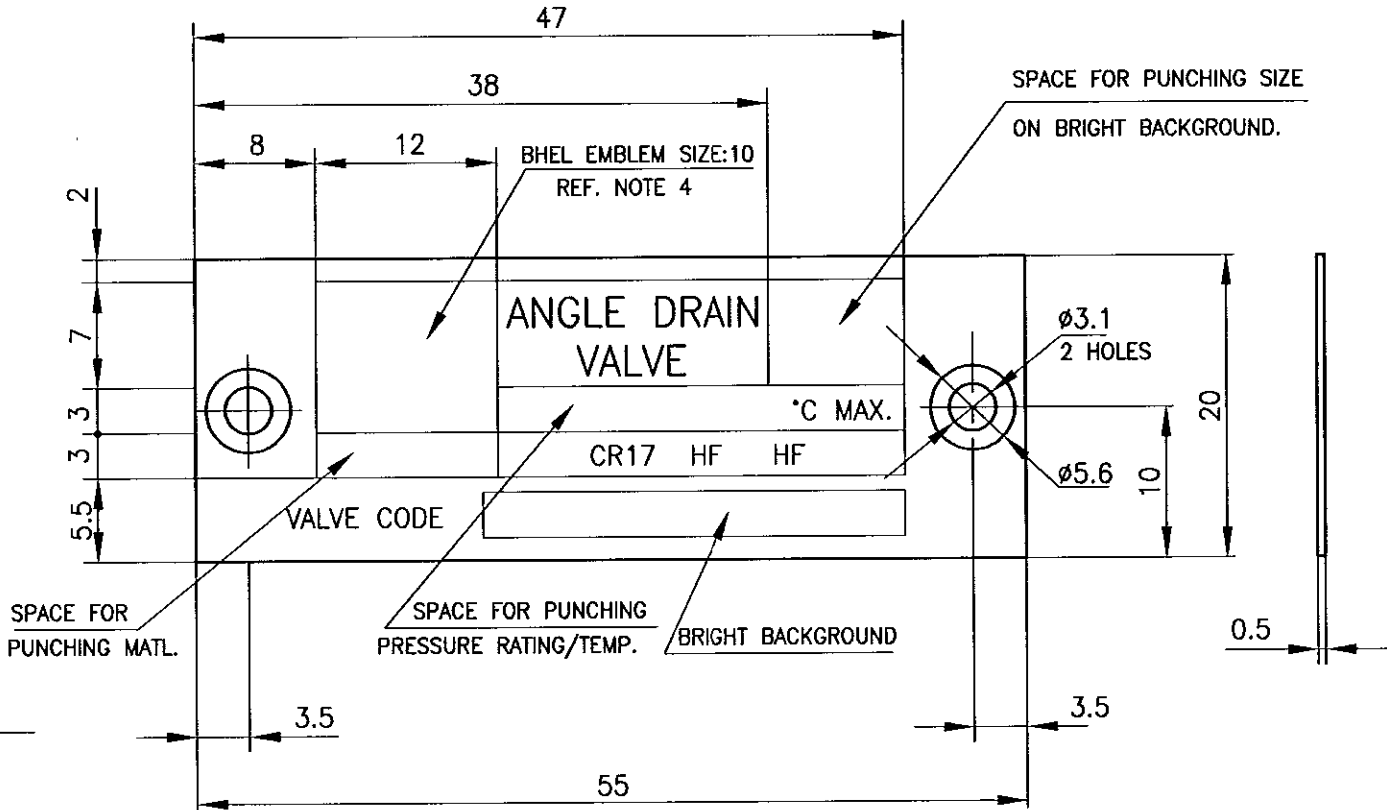

NOTES :-

1. MATERIAL : 18-8 Cr. Ni. STAINLESS STEEL.
2. THE NAME PLATE SHALL HAVE RAISED BRIGHT POLISHED LETTERS, MONOGRAM, ETC. ON ETCHED BLACK ENAMELLED BACKGROUND.
3. THE ENAMEL SHALL BE CRACK RESISTING SO THAT WHEN BENT THE ENAMEL DOES NOT CRACK.
4. MONOGRAM SHALL BE BASED ONCORPORATE STANDARED No. AA 040 11 20 (LATEST REV.)
5. FINAL THICKNESS OF THE NAME PLATE AFTER ETCHING, ENAMELLING & POLISHING SHALL NOT BE LESS THAN 0.5mm. SUPPLIERS SHALL TAKE SUITABLE RAW MATERIAL THICKNESS TO MEET THE SPECIFIED FINAL THICKNESS.

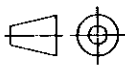
NO OFF	DESCRIPTION	MATL CODE	MATL SPECN	HEAT TREATMENT	SCRAP SORT	NET WT (kg)	GROSS WT (kg)	DRAWING No	ITEM No	
 BHARAT HEAVY ELECTRICALS LTD., UNIT: HIGH PRESSURE BOILER PLANT. TIRUCHIRAPALLI 620014.						DRN	NAME	SIGN	DATE	NO.OF VAR
						CHD	M.SRINIVASAN		11.08.04	
						APPD	P.Boomnathan		11.08.04	
							K.S.RAMAN		11.08.04	
DEPT VL	/		SCALE	WEIGHT (KG).	REFERENCE INFORMATION				NO. OF ITEMS	
CODE			N T S	0.003	COMP. CODE: 96 465 174 0000 CAD:F426545					
TITLE						CARD CODE	DRAWING NO.			REV
NAME PLATE						U 01	4-V-3222-26545			

FOR TOLERANCES OF UNTOLERANCED DIMENSIONS

ALL DIMENSIONS ARE IN MILLIMETRES.
DURING MANUFACTURE REFER RELEVANT QCP/QP

REV	DATE	ALTERED
		CHD & APPD

CAUTION: The information on this document is the property of BHARAT HEAVY ELECTRICALS LTD. It must not be used directly or indirectly in any way detrimental to the interest of the company.

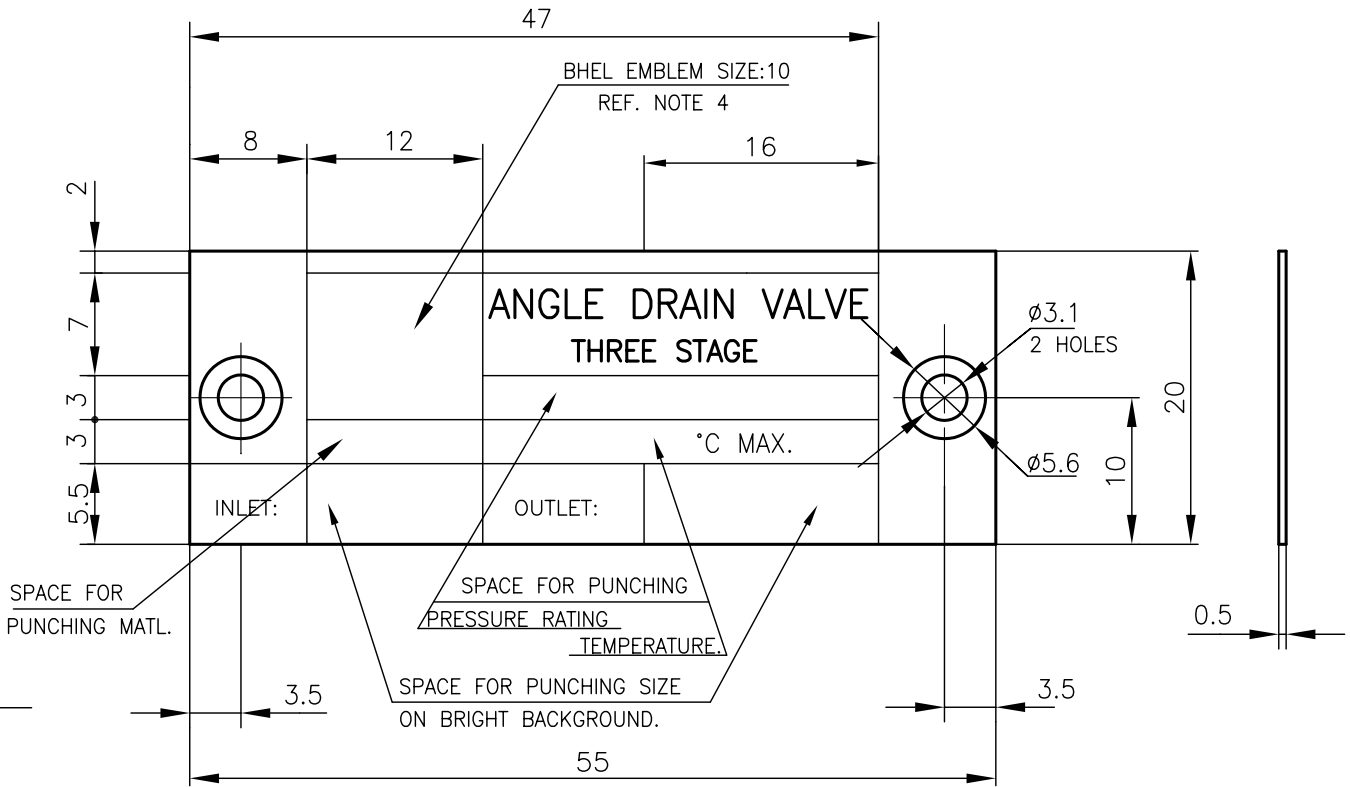

NOTES :-

1. MATERIAL : 18-8 Cr. Ni. STAINLESS STEEL.
2. THE NAME PLATE SHALL HAVE RAISED BRIGHT POLISHED LETTERS, MONOGRAM, ETC. ON ETCHED BLACK ENAMELLED BACKGROUND.
3. THE ENAMEL SHALL BE CRACK RESISTING SO THAT WHEN BENT THE ENAMEL DOES NOT CRACK.
4. MONOGRAM SHALL BE BASED ONCORPORATE STANDARED No. AA 040 11 20 (LATEST REV.)
5. FINAL THICKNESS OF THE NAME PLATE AFTER ETCHING, ENAMELLING & POLISHING SHALL NOT BE LESS THAN 0.5mm. SUPPLIERS SHALL TAKE SUITABLE RAW MATERIAL THICKNESS TO MEET THE SPECIFIED FINAL THICKNESS.

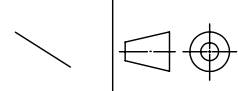
-	-	-	-	-	-	-	-	-	-			
NO OFF	DESCRIPTION	MATL CODE	MATL SPECN	HEAT TREATMENT	SCRAP SORT	NET WT (kg)	GROSS WT (kg)	DRAWING No	ITEM No			
 365-122	BHARAT HEAVY ELECTRICALS LTD., UNIT: HIGH PRESSURE BOILER PLANT. TIRUCHIRAPALLI 620014.							NAME	M. SRINIVASAN	SIGN	DATE	NO. OF VAR
								CHD	K.S. RAMAN		24.04.07	
								APPD	K. ARUN		24.04.07	
DEPT VL		SCALE	WEIGHT (KG).		REFERENCE INFORMATIONS				NO. OF ITEMS			
CODE		N T S	0.003		COMP. CODE: 96 465 230 0000 CAD:F426698							
TITLE						CARD CODE	DRAWING NO.			REV		
NAME PLATE						U 01	4-V-3246-26698					

ALL DIMENSIONS ARE IN MILLIMETRES.
DURING MANUFACTURE REFER RELEVANT QCP/QP

FOR TOLERANCES OF UNTOLERANCED DIMENSIONS

DCP No. 800479	ALT: <i>Resj</i>	APPD: <i>Mparaman</i>
REV 01	CHD: <i>Resj</i>	DATE: 27-6-05
ZONE △01	REVISED AND REDRAWN IN CAD.	

CAUTION: The information on this document is the property of BHARAT HEAVY ELECTRICALS LTD. It must not be used directly or indirectly in any way detrimental to the interest of the company.

CORPORATE DRG ID
TP-DG-4-V-4124-07706

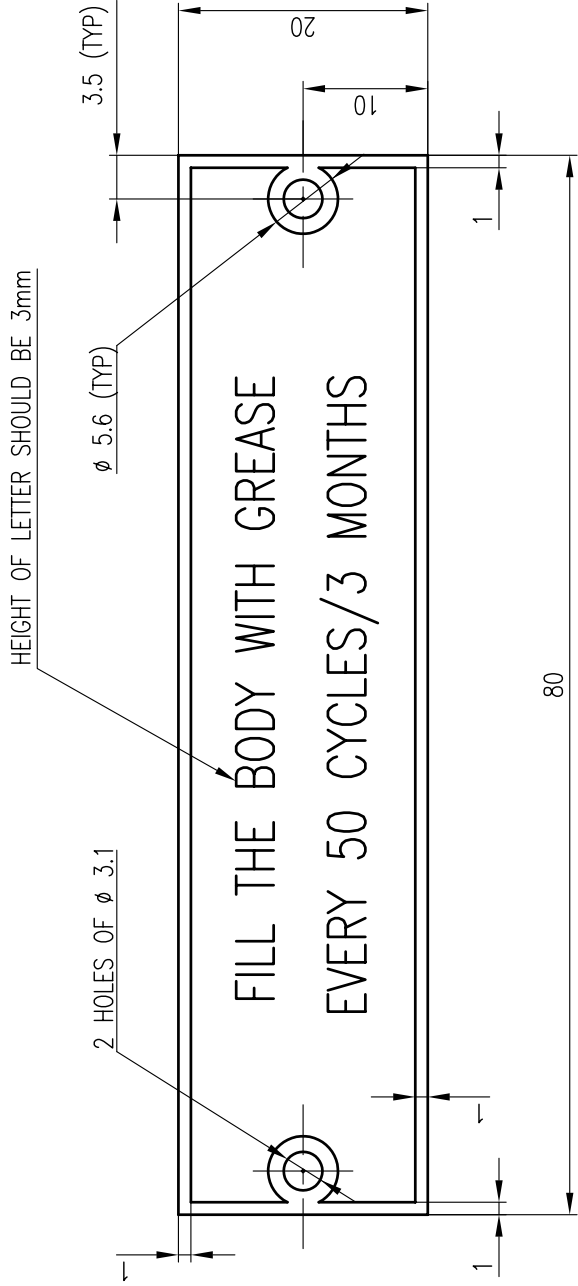

NOTES:-

1. MATERIAL : 18-8 STAINLESS STEEL, THICKNESS 1mm.
2. UNLESS OTHERWISE SPECIFIED FIGURES, SPACES AND BORDER TO BE RAISED AND BUFFED ON A BLACK BACKGROUND.
3. THE PLATING SHALL BE CRACK RESISTING SO THAT WHEN BENT, THE PLATING DOES NOT CRACK.
4. APPLICATION : USED IN GATE VALVE ASSY.

CAD_REF No. o407706

COMP. CODE : 96 464 032 0000

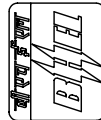
NO OFF	DESCRIPTION	MATL CODE	MATL SPECN	HEAT TREATMENT	SCRAP SORT	NET WT (kg)	GROSS WT (kg)	DRAWING No	ITEM No			
						0.013						
 BHARAT HEAVY ELECTRICALS LTD. UNIT: HIGH PRESSURE BOILER PLANT. TIRUCHIRAPALLI 620014.				DRN	T. RAJARAMAN	NAME	T. RAJARAMAN	SIGN	<i>T. Rajaraman</i>	DATE	27-6-05	NO. OF VAR
				CHD	T. RAJARAMAN				<i>T. Rajaraman</i>		27-6-05	
				APPD	V. ALAGARSWAMI				<i>V. Alagarswami</i>		27-6-05	
DEPT VL	SCALE			WEIGHT (KG)		REFERENCE INFORMATIONS						
CODE	N T S			—		BHEL DESIGN						
TITLE												
INSTRUCTION PLATE-GRE												
CARD CODE				DRAWING NO.				REV				
U 01				4-V-4124-07706				01				

CORPORATE DRG ID
TP-DG-4-V-4124-07706

©

Size A4

CAUTION: The information on this document is the property of BHARAT HEAVY ELECTRICALS LTD. It must not be used directly or indirectly in any way detrimental to the interest of the company.

REV	DATE	ALTERED
		CHECKED

ALL DIMENSIONS ARE IN MILLIMETRES

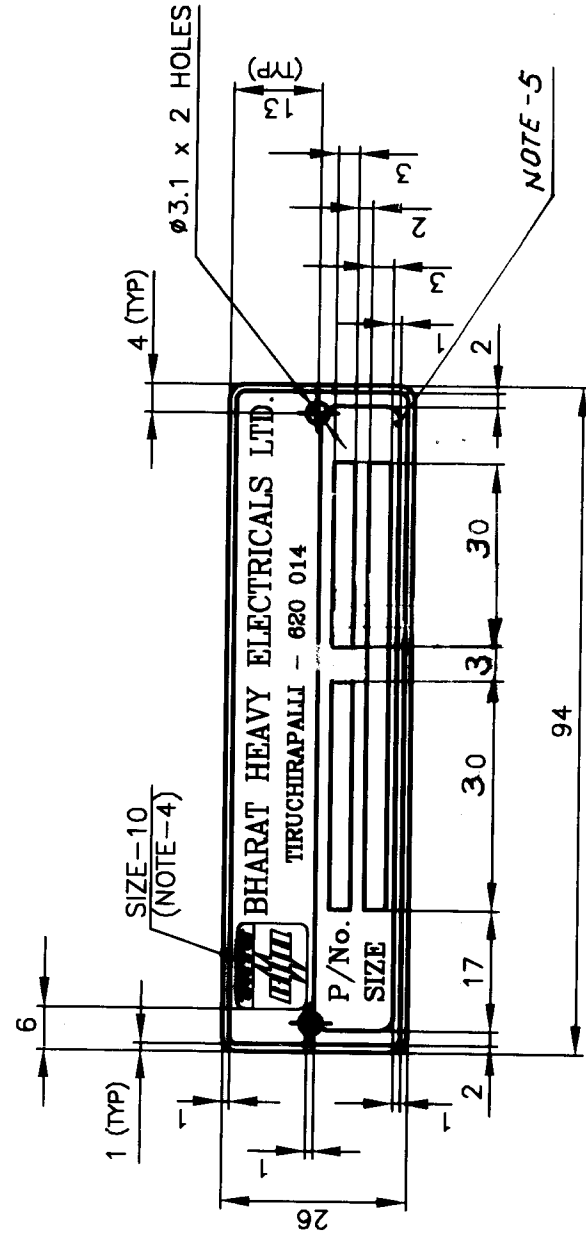

NOTES:

1. ALL LETTER HEIGHTS SHOULD BE SUITABLY SELECTED.
2. UNLESS OTHERWISE SPECIFIED FIGURES, SPACES AND BORDER TO BE RAISED AND BUFFED ON A BLACK BACK GROUND.
3. THE PLATING SHALL BE CRACK RESISTING SO THAT WHEN BENT, THE PLATING DOES NOT CRACK.
4. THE EMBLEM SHALL BE BASED ON CORP. STD. MONOGRAM 10-AA0401120 REV-01.
5. ALL CHARACTERS WITHIN THIS BORDER LINE ARE TO BE BRIGHT ON A BLACK BACKGROUND.

CAD REF 0407980

NO OFF	DESCRIPTION	MATL CODE	MATL SPECN	HEAT TREATMENT	SCRAP SORT	NET WT (KG)	GROSS WT (KG)	DRAWING NO	ITEM NO
-	96 464 530	18-8 ST. STEEL	1mm THICKNESS	-	-	0.02	-	-	-
BHARAT HEAVY ELECTRICALS LTD., UNIT: HIGH PRESSURE BOILER PLANT. TIRUCHIRAPALLI 680014.									
DEPT VL	GRADE OF UNTO L DIM	SCALE		WEIGHT (KG)		REFERENCE INFORMATION			
340	6-11-1	N T S		0.02		---			
TITLE									
NAME PLATE					DRAWING NO.				
(FOR TEST PLUG BUSHING)					4-V-4176-07980				
REV									

Size A4

FOR TOLERANCES OF UNTOLERANCED DIMENSIONS DURING MANUFACTURE REFER RELEVANT QCP/QP

ALL DIMENSIONS ARE IN MILLIMETRES.

DCP No. 800479	ALT: <i>Raj</i>	APPD: <i>Mparamani</i>
REV	CHD: <i>Raj</i>	DATE: 27-6-05
01	REVISED AND REDRAWN IN CAD	
ZONE		

CAUTION: The information on this document is the property of BHARAT HEAVY ELECTRICALS LTD. It must not be used directly or indirectly in any way detrimental to the interest of the company.

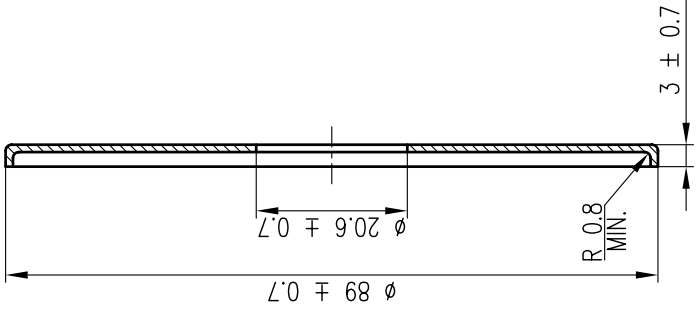
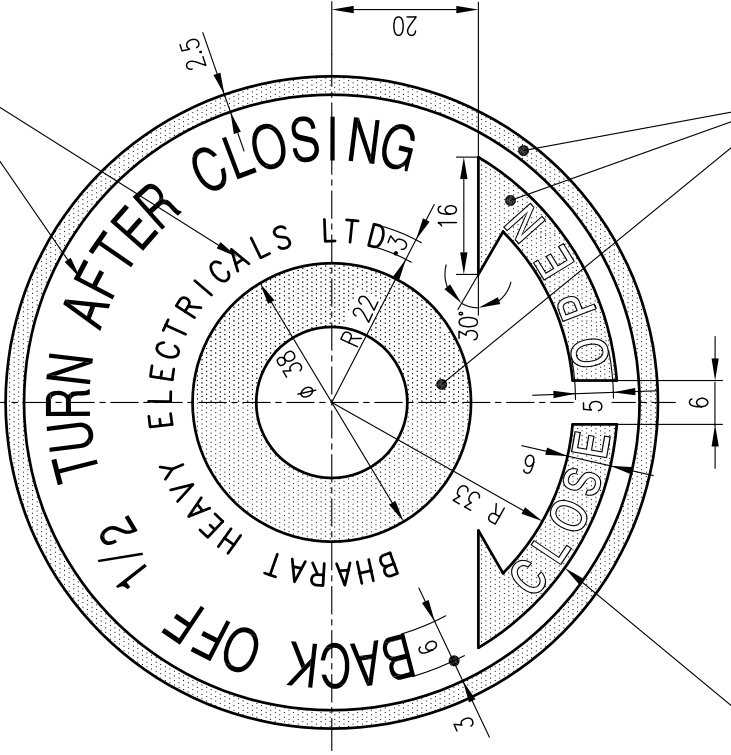

LETTERS SHALL BE MATL.BASE
IN COLOUR BACKGROUND.

TO BE COLOURED.
(BRIGHT RED)

NOTES:-

1. FILE OR LIGHTLY GRIND ANY SHARP EDGES LEFT ON PART FROM STAMPING.
2. MATERIAL : 1.14t (18GA) STAINLESS STEEL.

CAD REF No. 0407660

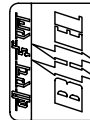
NO OFF	DESCRIPTION	MATL CODE	MATL SPECN	HEAT TREATMENT	SCRAP SORT	NET WT (kg)	GROSS WT (kg)	DRAWING No	ITEM No
	96 452 834					0.04			
				BHARAT HEAVY ELECTRICALS LTD., UNIT: HIGH PRESSURE BOILER PLANT. TIRUCHIRAPALLI 620014.		DRN	NAME	SIGN	DATE
365-122				WEIGHT (KG)		CHD	T.RAJARAMAN	<i>Rajaraman</i>	27-6-05
DEPT VL				SCALE		APPD	T.RAJARAMAN	<i>Rajaraman</i>	27-6-05
CODE 340				N T S		V.ALAGARSWAMI		<i>Mparamani</i>	27-6-05
TITLE				REFERENCE INFORMATION		NL. DRG. No. H400179 / REV-B SL No. 4010/1			
NAME PLATE				CARD CODE		NO. OF ITEMS			
				U 01		REV			
				DRAWING NO.		NO. OF VAR			
				4-V-4362-07660		01			

REV	DATE	ALTERED
		CHECKED

CAUTION: The information on this document is the property of BHARAT HEAVY ELECTRICALS LTD. It must not be used directly or indirectly in any way detrimental to the interest of the company.

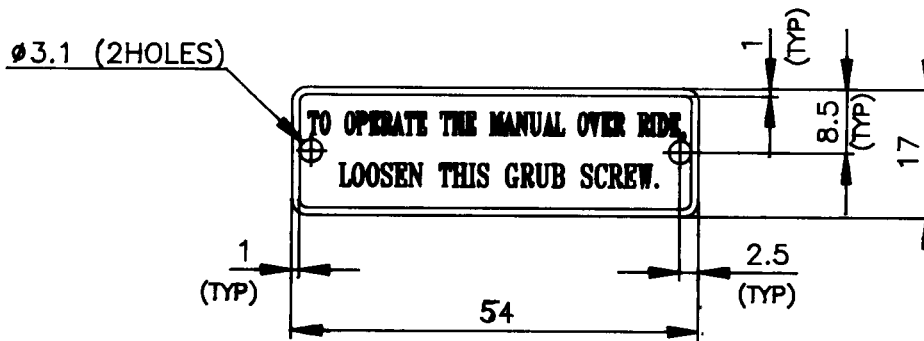



NOTES:

1. LETTER HEIGHTS SHOULD BE SUITABLY SELECTED.
2. THE PLATING SHALL BE CRACK RESISTING SO THAT WHEN BENT, THE PLATING DOES NOT CRACK.
3. ALL CHARACTERS WITHIN THIS BORDER LINE ARE TO BE BRIGHT ON A BLACK BACK GROUND.
4. UNLESS OTHERWISE SPECIFIED FIGURES, SPACES AND BORDER TO BE RAISED AND BUFFED ON A BLACK BACK GROUND.

TOLERANCE FOR UNTOLERANCED DIMENSIONS	
UPTO 6MM	- ± 0.1MM
> 6 UPTO 120 MM	- ± 0.2MM
MORE THAN 120 MM	- ± 0.5MM
ANGULAR TOLERANCE	± 0.5°
CHAMFER	- ± 5°

CAD REF o407905

NO OFF	DESCRIPTION	MATL CODE	MATL SPECN	HEAT TREATMENT	SCRAP SORT	NET WT (KG)	GROSS WT (KG)	DRAWING No	ITEM No
		96 464 386	18-8 ST. STEEL 1mm THICKNESS			0.01			
 BHARAT HEAVY ELECTRICALS LTD. UNIT: HIGH PRESSURE BOILER PLANT. TIRUCHIRAPALLI 620014.					DRN	V-ALAGARSWAMI	SIGN	DATE	NO. OF VAR
					CHD	V-ALAGAR SWAMI		14.01.95	
					APPD	J.ABRAHAM.		14.01.95	
DEPT VL	GRADE OF UNTOL. DIM		SCALE	WEIGHT (KG).	REFERENCE INFORMATION				NO. OF TIMES
CODE	C/M/I		NTS	0.01	---				027
TITLE					CARD CODE	DRAWING NO.			REV
NAME PLATE (FOR ACT. VALVE)					U 01	4-V-4752-07905			--

CAUTION : THE INFORMATION OF THIS DOCUMENT IS THE PROPERTY OF BHARAT HEAVY ELECTRICALS LIMITED IT MUST NOT BE USED DIRECTLY OR INDIRECTLY IN ANY WAY DETRIMENTAL TO THE INTEREST OF THE COMPANY

REV	DATE	ALTERED :
01	15-3-97	R. Mohan
ZONE		CHECKED & APPD:
DCN: P.S. 0595		

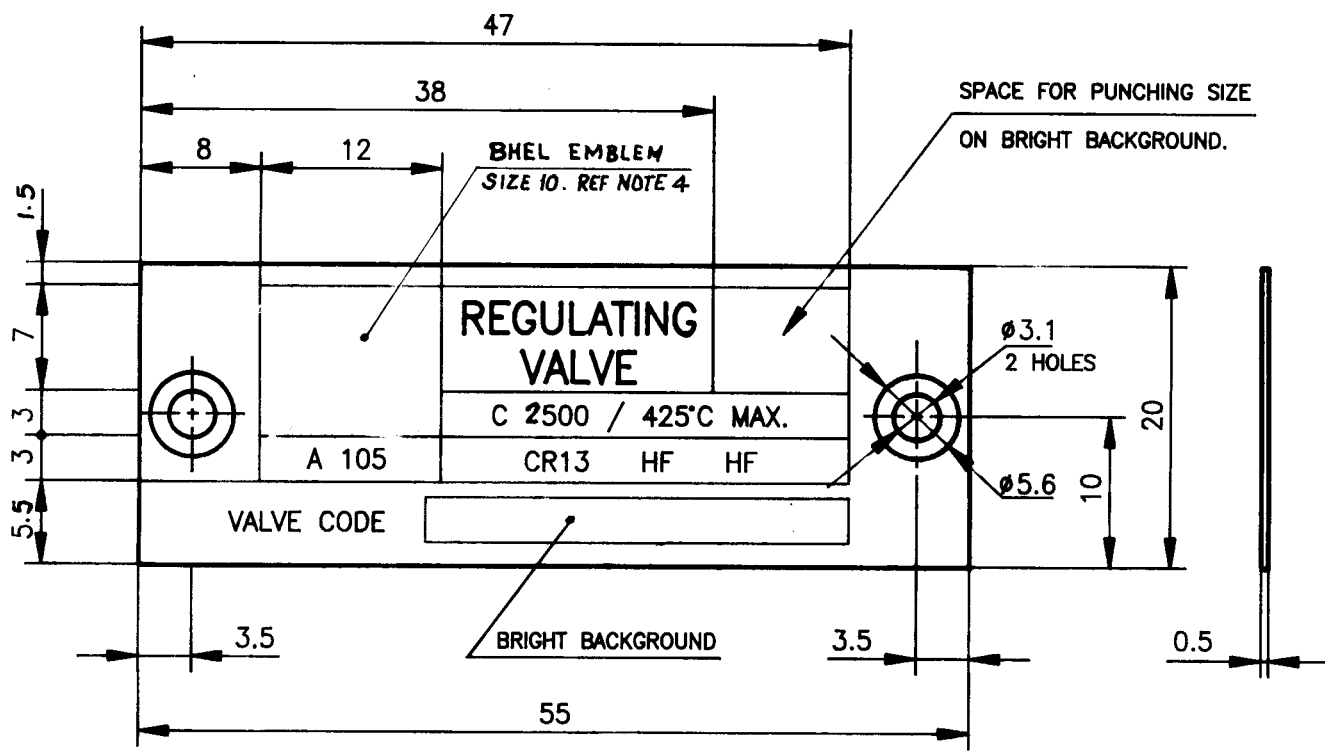

NOTES :-

1. MATERIAL : 18-8 Cr. Ni. STAINLESS STEEL.
2. THE NAME PLATE SHALL HAVE RAISED BRIGHT POLISHED LETTERS, MONOGRAM, ETC. ON ETCHED **BLACK ENAMELLED BACKGROUND**.
3. THE ENAMEL SHALL BE CRACK RESISTING SO THAT WHEN BENT THE ENAMEL DOES NOT CRACK.
4. MONOGRAM SHALL BE BASED ON CORPORATE STANDARD No. AA 040 11 20 (LATEST REVISION)
5. FINAL THICKNESS OF THE NAME PLATE AFTER ETCHING, ENAMELLING & POLISHING SHALL NOT BE LESS THAN 0.5mm. SUPPLIERS SHALL TAKE SUITABLE RAW MATERIAL THICKNESS TO MEET THE SPECIFIED FINAL THICKNESS.

SL No	DESCRIPTION	MATL CODE	MATL SPECN	HEAT TREATMENT	SCRAP SORT	NET WT (kg)	GROSS WT (kg)	COMP CODE DRAWING No	ITEM No
-------	-------------	-----------	------------	----------------	------------	-------------	---------------	----------------------	---------

	BHARAT HEAVY ELECTRICALS LTD., BOILER PLANT UNIT, TIRUCHIRAPALLI-620 014.		DRAWN N.P.ESWAR.	SIGN 	DATE 14.9.92
			CHECKED N.NAGARAJAN.		15.9.92
			APPROVED R.THIRUVENGADAM.		15.9.92

DEPT. VL	GRADE OF UNTOL DIM	FIRST ANGLE	SCALE	WEIGHT (kg)	COMP CODE / REF	ITEM No
CODE 320	C/M/F		N T S	0.003	96 456 214	

TITLE	DRG No.	REVISION
NAME PLATE	4-V-5213-06670	

CAUTION: The information on this document is the property of BHARAT HEAVY ELECTRICALS LTD. It must not be used directly or indirectly in any way detrimental to the interest of the company.

REV 01	DATE 15.3.97	ALTERED : P. Mohan. CHECKED & APPD: <i>Walt</i>
QUALITY REFERENCES REMOVED.		

DCH: FS:
0595

BHEL EMBLEM SIZE: 10
REF. NOTE: 4

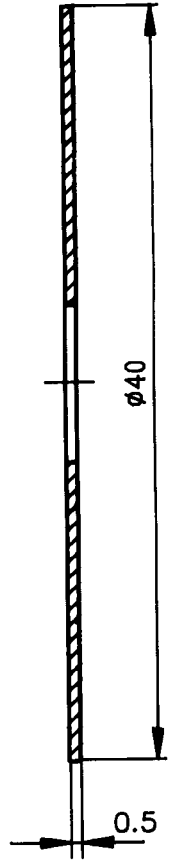
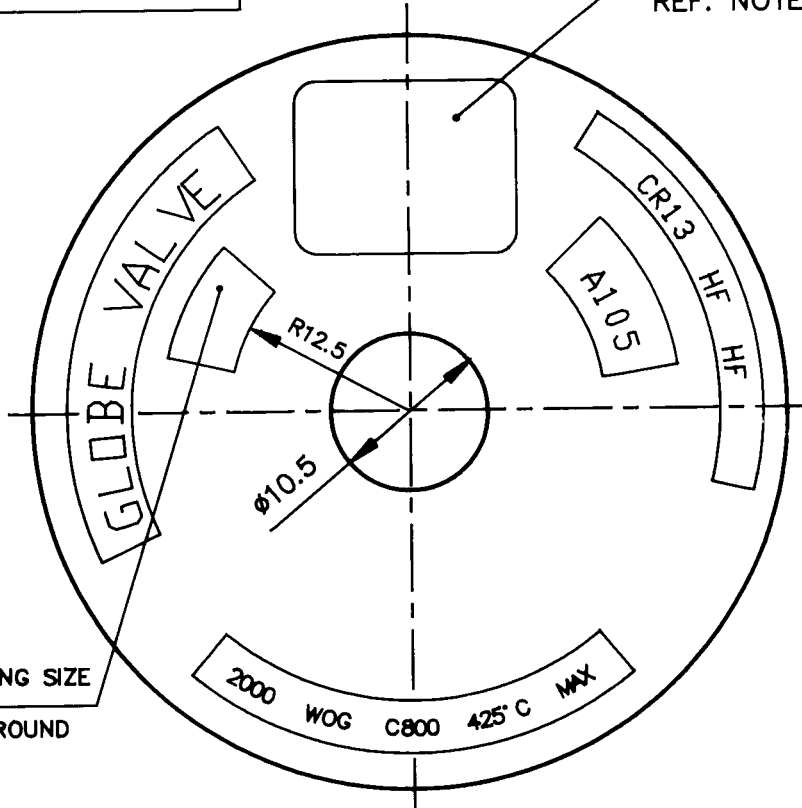

NOTES:

1. MATERIAL: 18-8 Cr. NI STAINLESS STEEL
2. THE NAME PLATE SHALL HAVE RAISED BRIGHT POLISHED LETTERS, EMBLEM ETC. ON ETCHED BLACK ENAMELLED BACKGROUND
3. THE ENAMEL SHALL BE CRACK RESISTING SO THAT WHEN BENT THE ENAMEL DOES NOT CRACK.
4. MONOGRAM SHALL BE BASED ON CORPORATE STANDARD No. AA 040 11 20 (LATEST REVISION)
5. FINAL THICKNESS OF THE NAME PLATE AFTER ETCHING, ENAMELLING & POLISHING SHALL NOT BE LESS THAN 0.5mm. SUPPLIERS SHALL TAKE SUITABLE RAW MATERIAL THICKNESS TO MEET THE SPECIFIED FINAL THICKNESS.



NO OFF	DESCRIPTION	MATL CODE	MATL SPECN	HEAT TREATMENT	SCRAP SORT	NET WT (KG)	GROSS WT (KG)	DRAWING No	ITEM No	
	BHARAT HEAVY ELECTRICALS LTD., UNIT: HIGH PRESSURE BOILER PLANT. TIRUCHIRAPALLI 620014.	DRN	NAME	SIGN	DATE	NO. OF VAR				
		CHD	K.S.RAMAN.	<i>K.S.R.</i>	31.10.94					
		APPD	N.NAGARAJAN	<i>N.N.</i>	1.11.94					
DEPT VL	GRADE OF UNTOL DIM	SCALE	WEIGHT (KG).	REFERENCE INFORMATIONS		NO. OF ITEMS				
CODE 320	C/M/P	NTS	0.003	COMPONENT CODE: 964564980000 5313 S100 CAD: F406832						
TITLE					CARD CODE	DRAWING NO.		REV		
NAME PLATE					U 01	4-V-5313-06832		01		

FIRST ANGLE PROJECTION (ALL DIMENSIONS ARE IN MILLIMETRES)

REV. 01	DATE 18-09-90	ALTERED 14 Jan 95	REV. 02	DATE 15-3-97	ALTERED R. M. L.
CHECKED		APPROVED	CHECKED		APPROVED
MATERIAL CHANGED FROM ALUMINIUM TO STAINLESS STEEL THICKNESS 0.5mm WAS 1mm NOTE .5 ADDED.					
QUALITY REFERENCES REMOVED.					

CAUTION: THE INFORMATION ON THIS DOCUMENT IS THE PROPERTY OF BHARAT HEAVY ELECTRICALS LIMITED. IT MUST NOT BE USED DIRECTLY OR INDIRECTLY IN ANY WAY DETRIMENTAL TO THE INTEREST OF THE COMPANY.

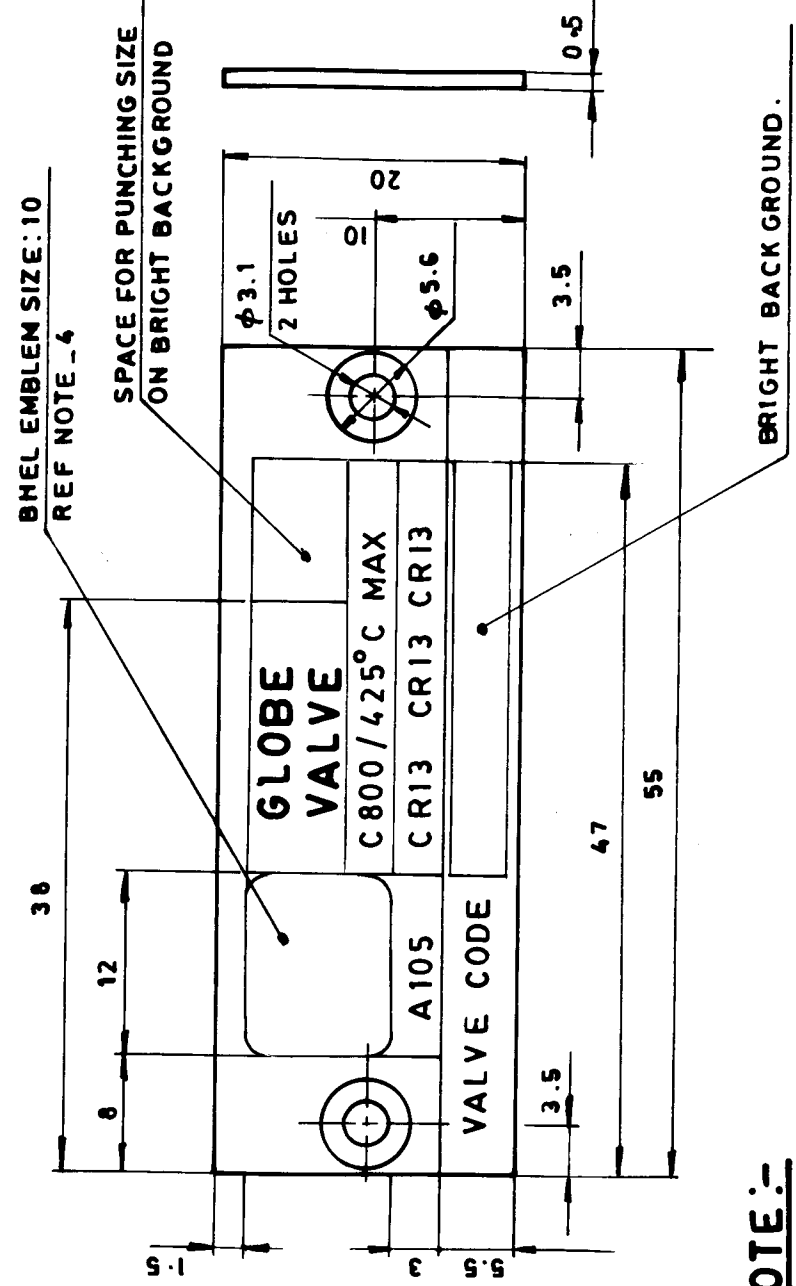

NOTE :-

1. MATERIAL : 18- 8 GT. NI STAINLESS STEEL.
2. THE NAME PLATE SHALL HAVE RAISED BRIGHT POLISHED LETTERS MONOGRAM , ETC. ON ETCHED BLACK ENAMELLED BACKGROUND
3. THE ENAMEL SHALL BE CRACK RESISTING SO THAT WHEN BENT THE ENAMAL DOES NOT CRACK .
4. MONOGRAM SHALL BE BASED ON CORPORATE STANDARD No AA 040 1120 (LATEST REVISION)
5. FINAL THICKNESS OF THE NAME PLATE AFTER ETCHING, ENAMELLING & POLISHING SHALL NOT BE LESS THAN 0.5mm. SUPPLIERS SHALL TAKE SUITABLE RAW MATERIAL THICKNESS TO MEET THE SPECIFIED FINAL THICKNESS .

96	456	045
DESCRIPTION		
VARIANT	Q.L.S	
MATL. CODE		A C
MATL. SPEC.		C
UNIT WT.		
QTY.		

		Bharat Heavy Electricals Ltd., BOILER PLANT UNIT TIRUCHIRAPALLI - 620 014		NAME <i>H. S. S.</i>	SIGN. <i>[Signature]</i>	DATE 15.6.89
DEPT	V L	GRADE OF UNTOOL. DIM.	SCALE	WEIGHT (kg)	REF. TO ASSY/OLD DRG.	ITEM NO.
CODE	320	<i>[Signature]</i>	NTS	0.003		10X
TITLE			DRAWING NO.			
NAME PLATE			4-V-5324-06534			

FOR TOLERANCES OF UNTOLERANCED DIMENSIONS
 DURING MANUFACTURE REFER RELEVANT QCP/QP

ALL DIMENSIONS ARE IN MILLIMETRES

CAUTION: The information on this document is the property of BHARAT HEAVY ELECTRICALS LTD. It must not be used directly or indirectly in any way detrimental to the interest of the company.

REV	DATE	ALTERED	R. Mohan
01	15-3-97	CHECKED & APPD:	<i>[Signature]</i>
QUALITY REFERENCES REMOVED.			
DCN:FS: 0595			

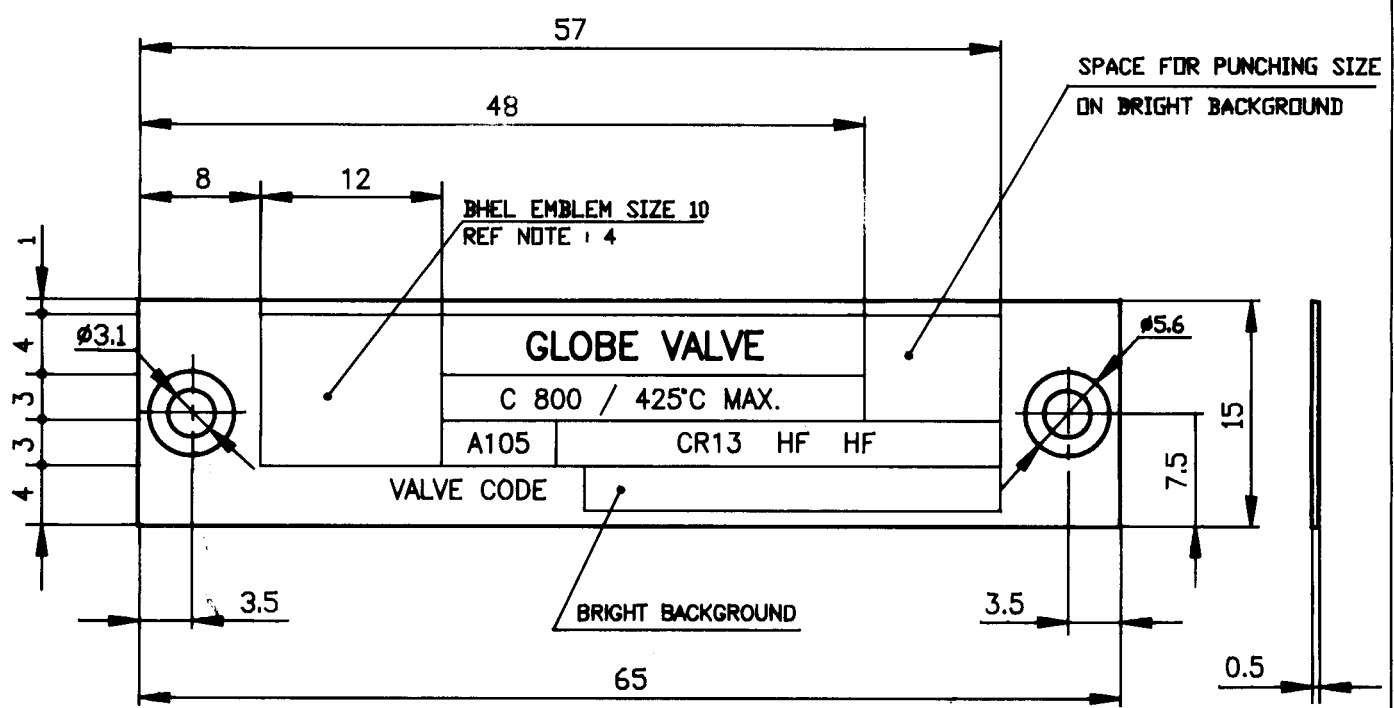

NOTES:

1. MATERIAL : 18-8 Cr. Ni. STAINLESS STEEL.
2. THE NAME PLATE SHALL HAVE RAISED BRIGHT POLISHED LETTERS, MONOGRAM, ETC. ON ETCHED BLACK ENAMELLED BACKGROUND.
3. THE ENAMEL SHALL BE CRACK RESISTING SO THAT WHEN BENT THE ENAMEL DOES NOT CRACK.
4. MONOGRAM SHALL BE BASED ON CORPORATE STANDARD No. AA 040 11 20 (LATEST REVISION)
5. FINAL THICKNESS OF THE NAME PLATE AFTER ETCHING, ENAMELLING & POLISHING SHALL NOT BE LESS THAN 0.5mm. SUPPLIERS SHALL TAKE SUITABLE RAW MATERIAL THICKNESS TO MEET THE SPECIFIED FINAL THICKNESS.



NO OFF	DESCRIPTION	MATL CODE	MATL SPECN	HEAT TREATMENT	SCRAP SORT	NET WT (KG)	GROSS WT (KG)	DRAWING No	ITEM No
BHARAT HEAVY ELECTRICALS LTD., UNIT: HIGH PRESSURE BOILER PLANT, TIRUCHIRAPALLI 620014.					DRN	NAME	SIGN	DATE	NO. OF VAR
					CHD	M.SRINIVASAN	<i>[Signature]</i>	08.10.94	
					APPD	K.RAVICHANDRAN	<i>[Signature]</i>	08.10.94	
						N.NAGARAJAN.	<i>[Signature]</i>	08.10.94	
DEPT VL	GRADE OF UNTOL DIM	SCALE		WEIGHT (KG).		REFERENCE INFORMATIONS			NO. OF VAR
CODE 320	e / M / J	N T S		0.003		COMPONENT CODE: 96 456 489 0000 5326 S100 CAD: F406818			
TITLE					CARD CODE	DRAWING NO.			REV
NAME PLATE					U 01	4-V-5326-06818			10

FOR TOLERANCES OF UNTOLERANCED DIMENSIONS DURING MANUFACTURE REFER RELEVANT QCP/QP

ALL DIMENSIONS ARE IN MILLIMETRES.

REV	DATE	ALTERED
		CHD & APPD

CAUTION: The information on this document is the property of BHARAT HEAVY ELECTRICALS LTD. It must not be used directly or indirectly in any way detrimental to the interest of the company.

BHEL EMBLEM SIZE: 100
REF. NOTE: 4

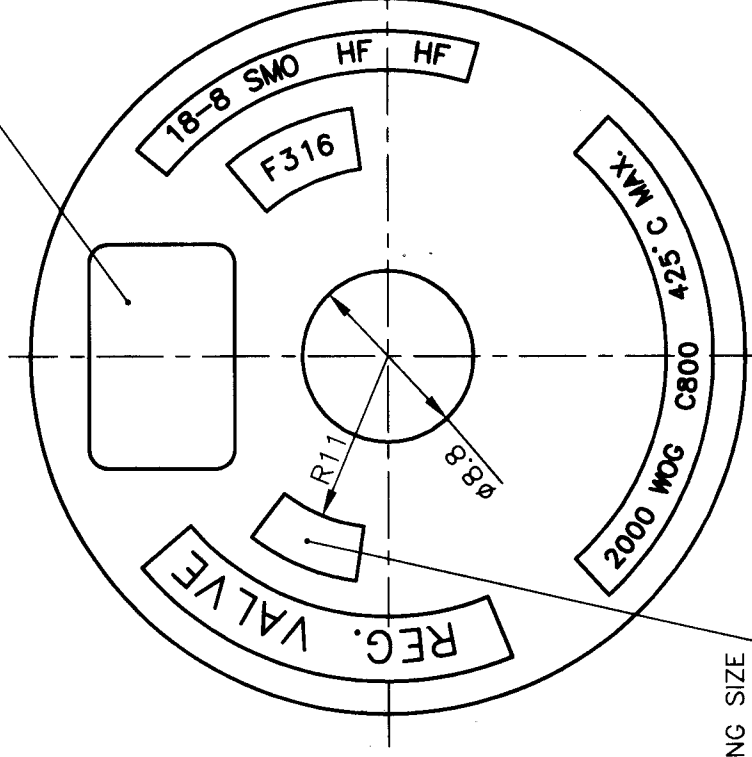

SPACE FOR PUNCHING SIZE
ON BRIGHT BACKGROUND

NOTES:

1. MATERIAL: 18-8 Cr. Ni STAINLESS STEEL.
2. THE NAME PLATE SHALL HAVE RAISED BRIGHT POLISHED LETTERS, EMBLEM ETC. ON ETCHED BLACK ENAMELLED BACKGROUND.
3. THE ENAMEL SHALL BE CRACK RESISTING SO THAT WHEN BENT THE ENAMEL DOES NOT CRACK.
4. MONOGRAM SHALL BE BASED ON CORPORATE STANDARD No. AA 040 11 20 (LATEST REVISION).
5. FINAL THICKNESS OF THE NAME PLATE AFTER ETCHING, ENAMELLING & POLISHING SHALL NOT BE LESS THAN 0.5mm. SUPPLIERS SHALL TAKE SUITABLE RAW MATERIAL THICKNESS TO MEET THE SPECIFIED FINAL THICKNESS.

NO OFF	DESCRIPTION	MATL CODE	MATL SPECN	HEAT TREATMENT	SCRAP SORT	NET WT (kg)	GROSS WT (kg)	DRAWING NO	ITEM NO.
-	-	-	-	-	-	-	-	-	-
<p>BHARAT HEAVY ELECTRICALS LTD. UNIT: HIGH PRESSURE BOILER PLANT. TIRUCHIRAPALLI 620014.</p>									
DEPT	VL	SCALE		WEIGHT (KG)	REFERENCE INFORMATION	COMP. CODE:		DATE	NO. OF VAR
365-122		NTS		0.003	365-122	01568580000		09.7.97	
CODE	320	TITLE		CARD CODE	DRN	NAME	SIGN	DATE	NO. OF VAR
		NAME PLATE		U 01	CHD	R. MOHAN	R. Mohan	09.7.97	
					APPD	K.S.RAMAN	Wob	10.7.97	
						N.NAGARAJAN			

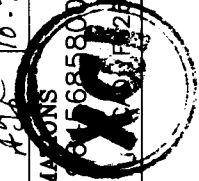

FOR TOLERANCES OF UNTOLERANCED DIMENSIONS DURING MANUFACTURE REFER RELEVANT QCP/QP

REV	DATE	ALTERED
		CHD & APPD

CAUTION: The information on this document is the property of BHARAT HEAVY ELECTRICALS LTD. It must not be used directly or indirectly in any way detrimental to the interest of the company.

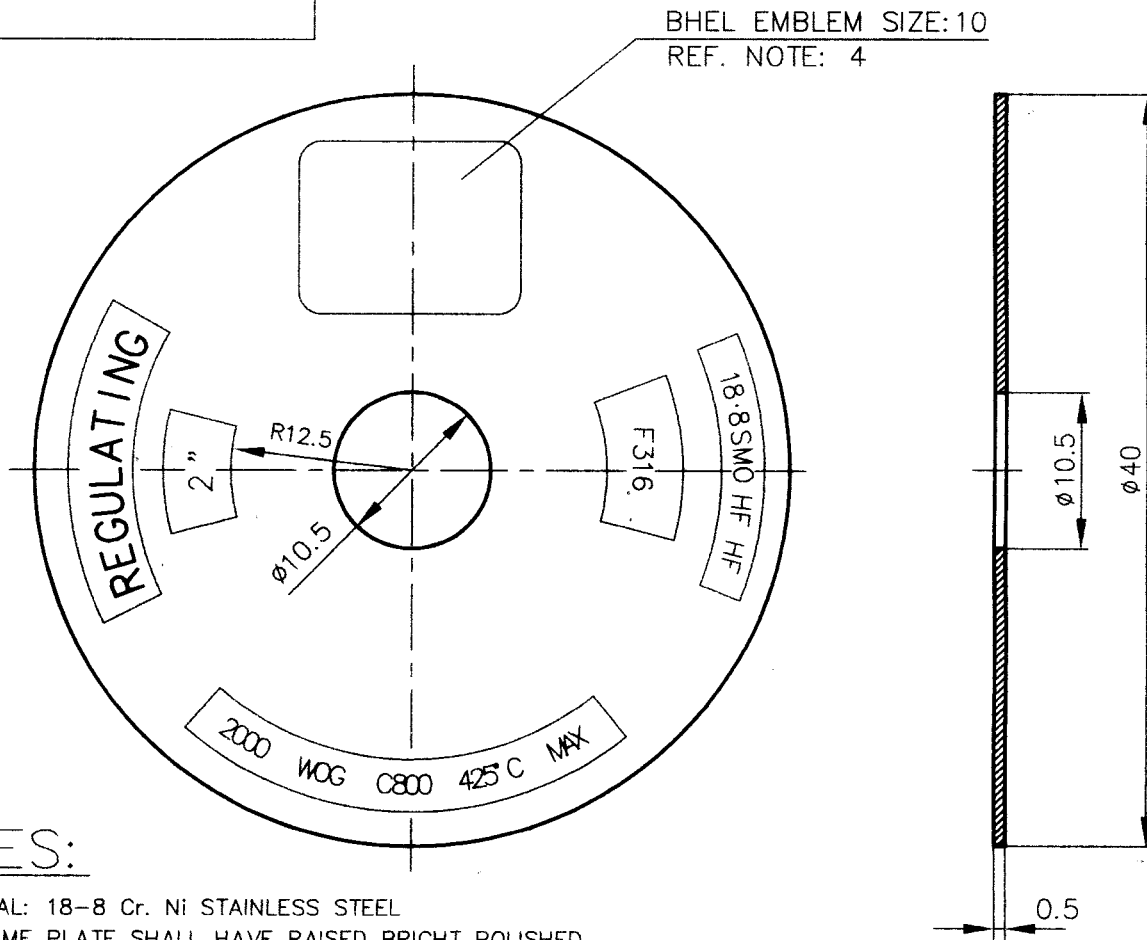

NOTES:

1. MATERIAL: 18-8 Cr. Ni STAINLESS STEEL
2. THE NAME PLATE SHALL HAVE RAISED BRIGHT POLISHED LETTERS, EMBLEM ETC. ON ETCHED BLACK ENAMELLED BACKGROUND
3. THE ENAMEL SHALL BE CRACK RESISTING SO THAT WHEN BENT THE ENAMEL DOES NOT CRACK.
4. MONOGRAM SHALL BE BASED ON CORPORATE STANDARD No. AA 040 11 20 (LATEST REVISION)
5. FINAL THICKNESS OF THE NAME PLATE AFTER ETCHING, ENAMELLING & POLISHING SHALL NOT BE LESS THAN 0.5mm. SUPPLIERS SHALL TAKE SUITABLE RAW MATERIAL THICKNESS TO MEET THE SPECIFIED FINAL THICKNESS.

-	-	-	-	-	-	-	-	-	-
NO OFF	DESCRIPTION	MATL CODE	MATL SPECN	HEAT TREATMENT	SCRAP SORT	NET WT (kg)	GROSS WT (kg)	DRAWING No	ITEM No
	 BHARAT HEAVY ELECTRICALS LTD. UNIT: HIGH PRESSURE BOILER PLANT. TIRUCHIRAPALLI 620014. 365-122								
		DRN	M.SRINIVASAN	SIGN	DATE	NO. OF VAR			
		CHD	P. BOOMINATHAN	SIGN	23.10.2k				
		APPD	K.S.RAMAN	SIGN	23.10.2k				
DEPT VL	CODE	SCALE	WEIGHT (KG).	REFERENCE INFORMATIONS	NO. OF ITEMS				
		NTS	0.003	COMP CODE : 96-6500-0001 C/4-5557-26331					
TITLE	CARD CODE	DRAWING NO.	REV						
NAME PLATE	U 01	4-V-5557-26331							

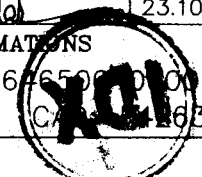

REV. 01	DATE 15-0-90	CHECKED	REV. 02	DATE 15-3-97	ALTERED: P. Mohan
MATERIAL CHANGED FROM ALUMINIUM TO STAINLESS STEEL THICKNESS 0.5mm WAS 1mm NOTE 5 ADDED.			QUALITY REFERENCES REMOVED.		

CAUTION: THE INFORMATION ON THIS DOCUMENT IS THE PROPERTY OF BHARAT HEAVY ELECTRICALS LIMITED. IT MUST NOT BE USED DIRECTLY OR INDIRECTLY IN ANY WAY DETRIMENTAL TO THE INTEREST OF THE COMPANY.

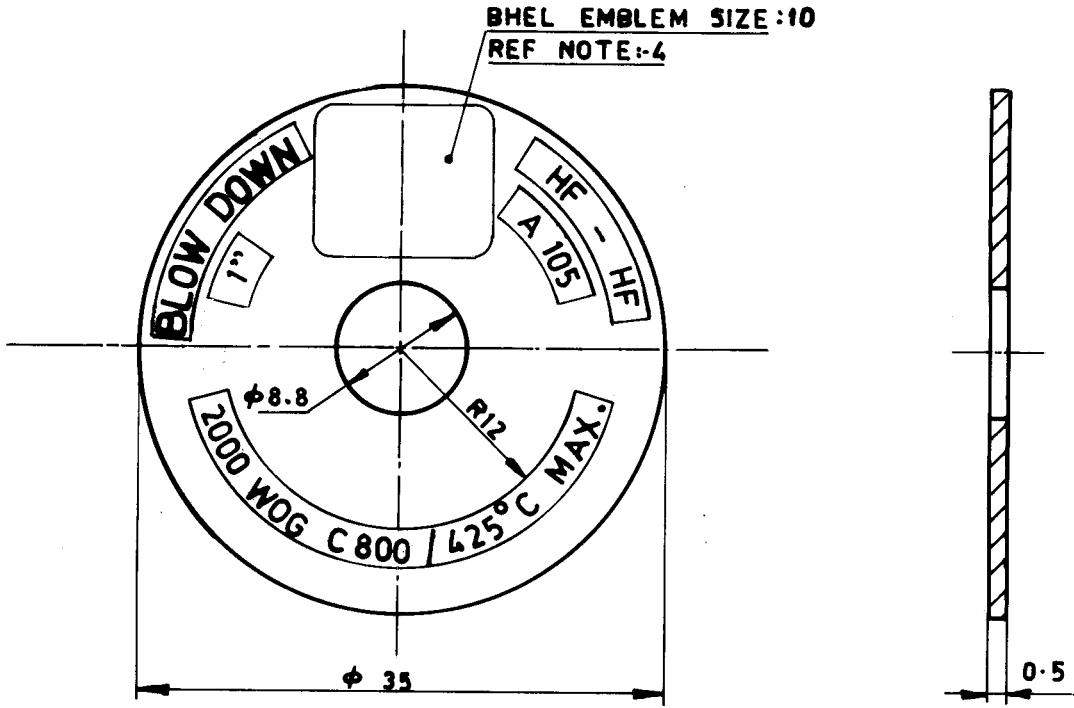

NOTE :-

1. MATERIAL : 18-8 Cr. Ni STAINLESS STEEL .
2. THE NAME PLATE SHALL HAVE RAISED BRIGHT POLISHED LETTERS MONOGRAM ETC ON ETCHED BLACK ENAMELLED BACKGROUND
3. THE ENAMEL SHALL BE CRACK RESISTING SO THAT WHEN BENT THE ENAMEL DOES NOT CRACK
4. MONOGRAM SHALL BE BASED ON CORPORATE STD. No. AA 040 11 20 (LATEST REVISION)
5. FINAL THICKNESS OF THE NAME PLATE AFTER ETCHING, ENAMELLING & POLISHING SHALL NOT BE LESS THAN 0.5mm. SUPPLIERS SHALL TAKE SUITABLE RAW MATERIAL THICKNESS TO MEET THE SPECIFIED FINAL THICKNESS.



<p>Bharat Heavy Electricals Ltd., BOILER PLANT UNIT TIRUCHIRAPALLI — 620 014</p>		DRN.	NAME	SIGN.	DATE
		CHD.	P. JAYARAMAN.		
		APPD.		<i>[Signature]</i>	26.05.89
DEPT. CODE	GRADE OF UNTOL. DIM. G/M/F		SCALE	WEIGHT (kg.)	REF. TO ASSY./OLD DRG.
			NTS	0.002	96 456 099
TITLE			CARD CODE	DRAWING NO.	REV.
NAME PLATE			U 01	4-V-5603-06539	02

CAUTION THE INFORMATION ON THIS DOCUMENT IS THE PROPERTY OF BHARAT HEAVY ELECTRICALS LTD IT MUST NOT BE USED DIRECTLY OR INDIRECTLY IN ANY WAY DETRIMENTAL TO THE INTEREST OF THE COMPANY.

REV 01	DATE	ALTERED
	CHECKED	CHECKED
REV 02	DATE	ALTERED

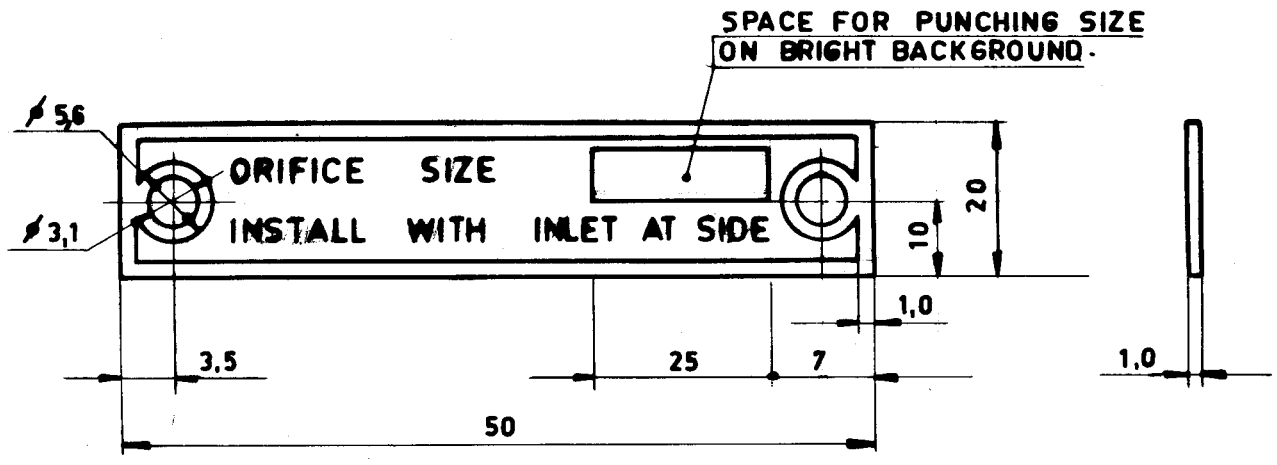

NOTE

1. MATERIAL : ALUMINIUM.
2. THE NAME PLATE SHALL HAVE RAISED BRIGHT POLISHED LETTERS ON ETCHED BLACK BACKGROUND.
3. THE PLATING SHALL BE CRACK RESISTING SO THAT WHEN BENT THE PLATING DOES NOT CRACK.

MICROFILMED ON
ROLL 00226 FRAME 203



05-249/A

BHARAT HEAVY ELECTRICALS LIMITED
BOILER PLANT UNIT, TIRUCHIRAPALLI-620014

DEPT	CODE		SCALE 2:1	WEIGHT (kg.)	IT.No.
TITLE NAME PLATE					DATE 21-9-79
DRAWN R. C. SEKHAR			CHECKED		APPROVED

DIMENSIONS TO BE CONTROLLED WITHIN LIMITS AS SHOWN. MACHINING TOLERANCE ± 0.25 mm. UNLESS OTHERWISE SHOWN NON-MACHINING TOLERANCE \pm

4 DRAWING No. 15 16 REV 17
CARD CODE 4-V-5610-0690
TP-DG-4-V-5610-06024

CAUTION : THE INFORMATION OF THIS DOCUMENT IS THE PROPERTY OF BHARAT HEAVY ELECTRICALS LIMITED IT MUST NOT BE USED DIRECTLY OR INDIRECTLY IN ANY WAY DETRIMENTAL TO THE INTEREST OF THE COMPANY.

REVISED	DATE
CHECKED	DATE
ZONE	

/6.3

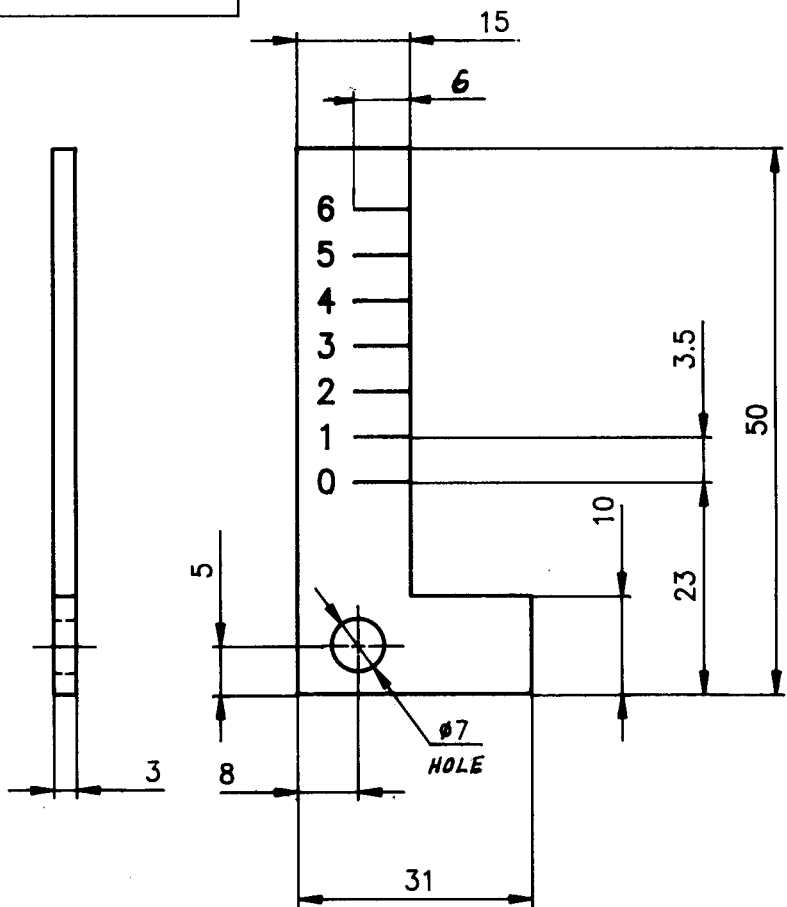

NOTE:

01. MATERIAL : 18-8 Cr. Ni. STAINLESS STEEL
02. THE INDICATOR SHALL HAVE RAISED BRIGHT POLISHED LETTERS & GRADUATION LINES. ON ETCHED BLACK ENAMELLED BACKGROUND.
03. FINAL THICKNESS OF THE INDICATOR PLATE AFTER ETCHING ENAMELLING AND POLISHING SHALL NOT BE LESS THAN 3 mm. SUPPLIERS SHALL TAKE SUITABLE RAW MATERIAL THICKNESS TO MEET THE SPECIFIED FINAL THICKNESS.
04. HEIGHT OF LETTERS - 2.5 mm.

01		96456217				0.021			
SL No	DESCRIPTION	MATL CODE	MATL SPECN	HEAT TREATMENT	SCRAP SORT	NET WT (kg)	GROSS WT (kg)	COMP CODE	ITEM No
								DRAWING No	

BHARAT HEAVY ELECTRICALS T.D.,
BOILER PLANT UNIT, TIRUCHIRAPALLI-620 014.

	DRAWN M.SRINIVASAN CHECKED N.PARAMESWARAN APPROVED N.NAGARAJAN	AME SIGN DATE 12.5.92
---	---	--------------------------------

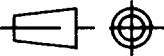
PART VL CODE	GRADE OF UNTOL DIM C/M/F	FIR T ANGLE 	SCALE NTS	EIGHT (kg) 0.021	COMP CODE / REF 96456217	ITEM No 140
-----------------	-----------------------------	--	--------------	---------------------	-----------------------------	----------------



TITLE INDICATOR	DRG No 4-V-5620-06691	REVISION
---------------------------	---------------------------------	----------

REV	DATE	ALTD: <i>R. Mohan</i>		
01	15.3.97	CHD & APPD: <i>WJ</i>		
DCN:R:	QUALITY REFERENCES REMOVED.			
0595				

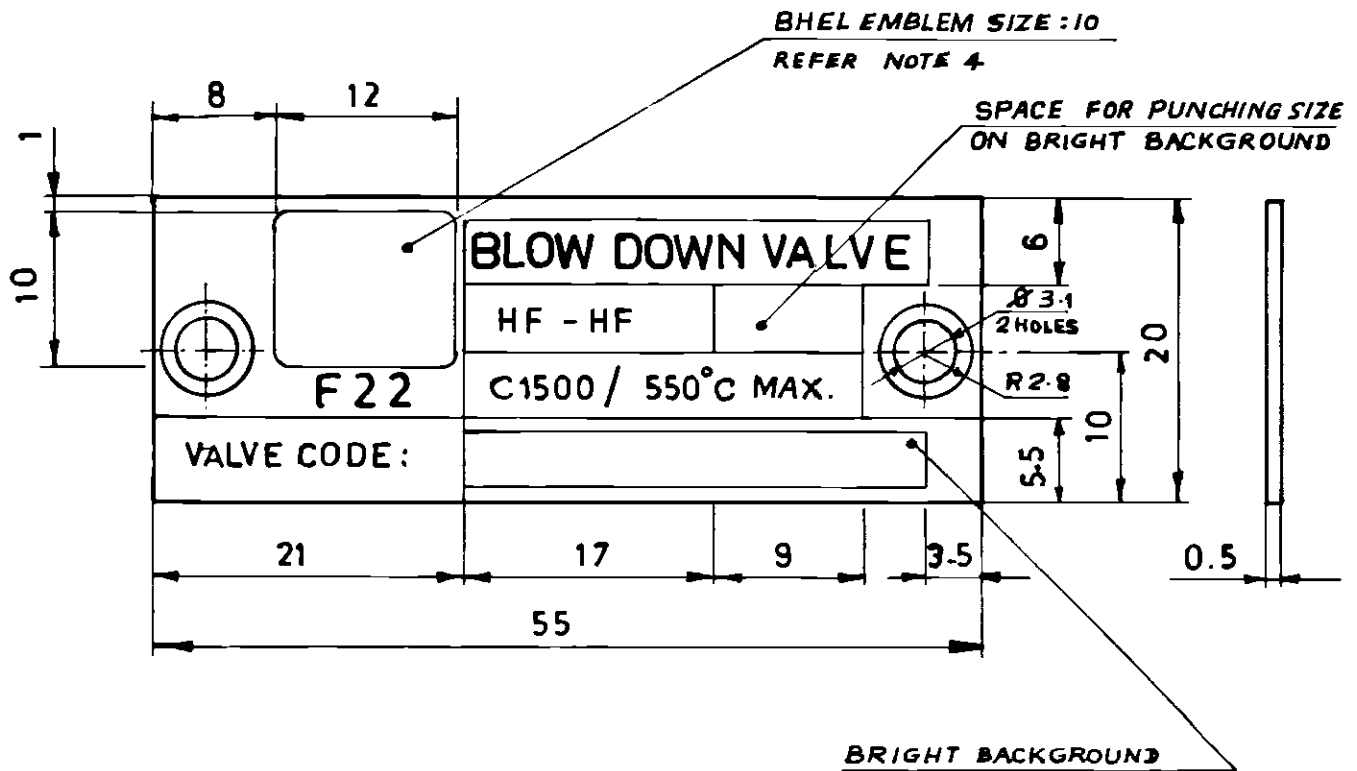

NOTE:

1. MATERIAL: 18-8 Cr.Ni. STAINLESS STEEL.
2. NAME PLATE SHALL HAVE RAISED BRIGHT POLISHED LETTERS MONOGRAM ETC. ON ETCHED BLACK ENAMELLED BACKGROUND
3. THE ENAMEL SHALL BE CRACK RESISTING SO THAT WHEN BENT, THE ENAMEL DOES NOT CRACK.
4. MONOGRAM SHALL BE BASED ON CORPORATE STANDARD NO. AA 040 11 20 (LATEST REVISION)
5. FINAL THICKNESS OF THE NAME PLATE AFTER ETCHING, ENAMELLING & POLISHING SHALL NOT BE LESS THAN 0.5 mm. SUPPLIERS SHALL TAKE SUITABLE RAW MATERIAL THICKNESS TO MEET THE SPECIFIED FINAL THICKNESS.

		96 456 181									
NO. OF PIECES	NAME - DIMENSIONS	MATERIAL CODE	FINAL MATERIAL	INITIAL MATERIAL	SCRAP SORT	NET Wt (kg)	GROSS Wt (kg)	DRAWING NO.	ITEM NO.		
REMARKS								TOTAL NET Wt (kg) 0.01			
NTS	SCALE	<i>R. Mohan</i>		ALTERATIONS		DATE	SIGNATURE	ALTERATION INDEX			
	CHECKED	<i>U. J.</i>									
	APPROVED	<i>WJ</i>									
	STDS. OFFICER			TRANS. COPY NO.							
	DATE	19-08-91									
		TYPE	GROUP	OLD DRG.		NEW DRG.		DRAWING NO.			
33-116		NAME PLATE		4 -V-5651 -06622							

CAUTION: The information on this document is the property of BHARAT HEAVY ELECTRICALS LTD. it must not be used directly or indirectly in any way detrimental to the interest of the company.

REV	DATE	ALTERED: <i>R. Mohan</i>
01	15-3-97	CHECKED & APPD: <i>[Signature]</i>
QUALITY REFERENCES REMOVED.		

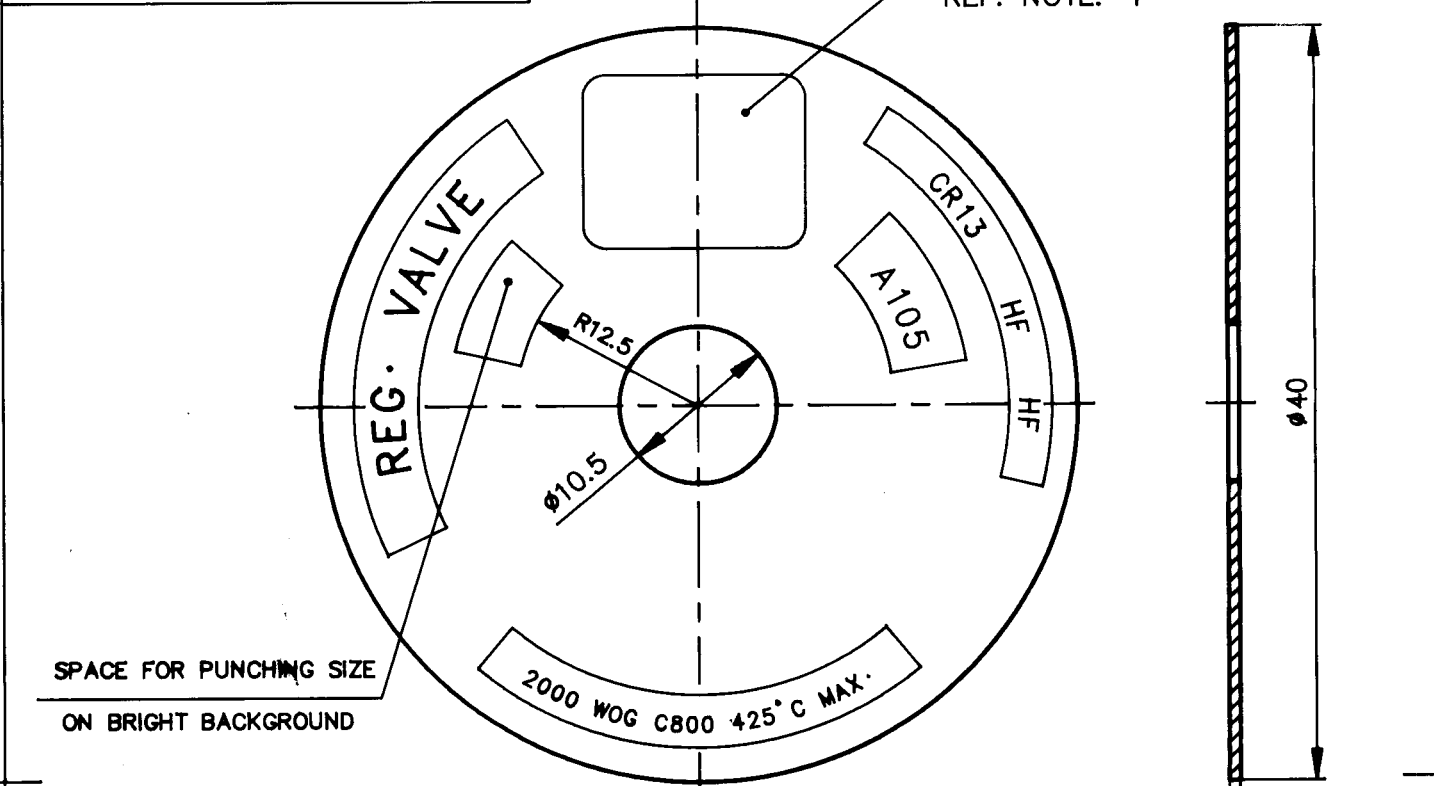

NOTES:

1. MATERIAL: 18-8 Cr. Ni STAINLESS STEEL
2. THE NAME PLATE SHALL HAVE RAISED BRIGHT POLISHED LETTERS, EMBLEM ETC. ON ETCHED BLACK ENAMELLED BACKGROUND
3. THE ENAMEL SHALL BE CRACK RESISTING SO THAT WHEN BENT THE ENAMEL DOES NOT CRACK.
4. MONOGRAM SHALL BE BASED ON CORPORATE STANDARD No. AA 040 11 20 (LATEST REVISION)
5. FINAL THICKNESS OF THE NAME PLATE AFTER ETCHING, ENAMELLING & POLISHING SHALL NOT BE LESS THAN 0.5mm. SUPPLIERS SHALL TAKE SUITABLE RAW MATERIAL THICKNESS TO MEET THE SPECIFIED FINAL THICKNESS.



NO OFF	DESCRIPTION	MATL CODE	MATL SPECN	HEAT TREATMENT	SCRAP SORT	NET WT (kg)	GROSS WT (kg)	DRAWING No	ITEM No	
BHARAT HEAVY ELECTRICALS LTD., UNIT: HIGH PRESSURE BOILER PLANT, TIRUCHIRAPALLI 620014.						DRN	NAME	SIGN	DATE	NO. OF VAR
						CHD	R. MOHAN	<i>R. Mohan</i>	30.12.94	
						APPD	K. RAVICHANDRAN	<i>[Signature]</i>	18.01.95	
							N. NAGARAJAN	<i>[Signature]</i>	19.1.95	
DEPT VL	GRADE OF UNTOL. DIM	SCALE		WEIGHT (KG).		REFERENCE INFORMATIONS				NO. OF ITEMS
CODE 320	C / M / F	NTS		0.003		COMP. CODE: 964565150000				
						CAD: F406860				
TITLE						CARD CODE	DRAWING NO.			REV
NAME PLATE						U 01	4-V-5727-06860			01

CAUTION: The information on this document is the property of BHARAT HEAVY ELECTRICALS LTD. It must not be used directly or indirectly in any way detrimental to the interest of the company.

REV	DATE	ALTERED
01	15.3.97	R. Molan
		CHECKED \$ APPD

DCN: FS: 0597
 QUALITY REFERENCES REMOVED.

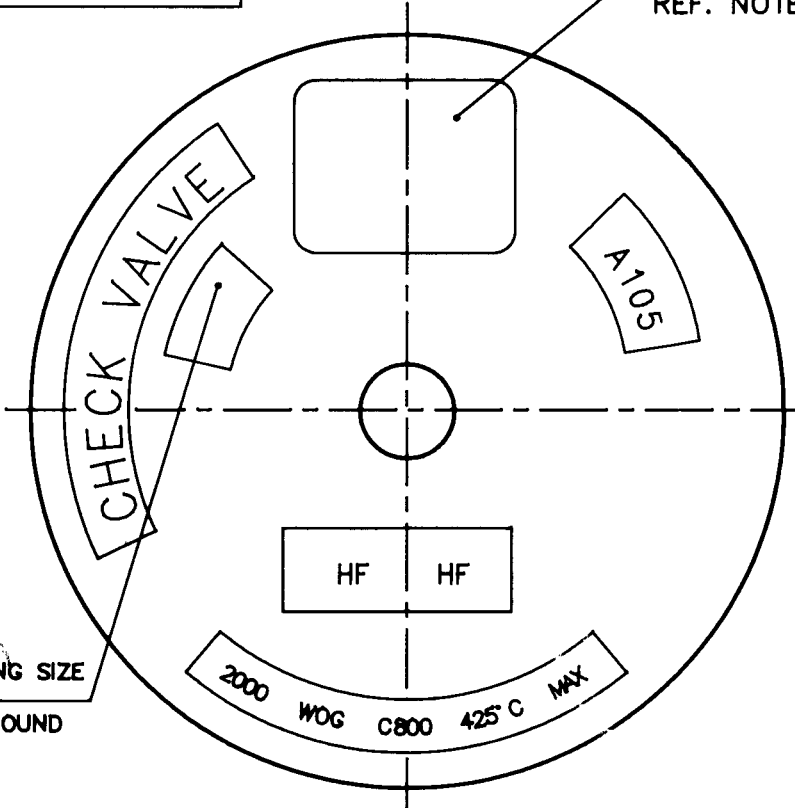

BHEL EMBLEM SIZE: 10
 REF. NOTE: 4



NOTES:

1. MATERIAL: 18-8 Cr. NI STAINLESS STEEL
2. THE NAME PLATE SHALL HAVE RAISED BRIGHT POLISHED LETTERS, EMBLEM ETC. ON ETCHED BLACK ENAMELLED BACKGROUND
3. THE ENAMEL SHALL BE CRACK RESISTING SO THAT WHEN BENT THE ENAMEL DOES NOT CRACK.
4. MONOGRAM SHALL BE BASED ON CORPORATE STANDARD No. AA 040 11 20 (LATEST REVISION)
5. FINAL THICKNESS OF THE NAME PLATE AFTER ETCHING, ENAMELLING & POLISHING SHALL NOT BE LESS THAN 0.5mm. SUPPLIERS SHALL TAKE SUITABLE RAW MATERIAL THICKNESS TO MEET THE SPECIFIED FINAL THICKNESS.



NO OFF	DESCRIPTION	MATL CODE	MATL SPECN	HEAT TREATMENT	SCRAP SORT	NET WT (Kg)	GROSS WT (Kg)	DRAWING No	ITEM No
	 BHARAT HEAVY ELECTRICALS LTD., UNIT: HIGH PRESSURE BOILER PLANT. TIRUCHIRAPALLI 620014.								
		DRN	M.SRINIVASAN	SIGN	M. Srinivasan	DATE	18.10.94		NO. OF VAR
		CHD	K.RAVCHANDRAN	SIGN	K. Ravchandan	DATE	18.10.94		
		APPD	N.NAGARAJAN	SIGN	N. Nagarajan	DATE	18.10.94		
DEPT VL	GRADE OF UNTOL DIM		SCALE	WEIGHT (KG).	REFERENCE INFORMATION				NO. OF ITEMS
CODE 320	C/M/F		NTS	0.003	COMPONENT CODE: 964564930000 CAD : F406825				
TITLE					CARD CODE	DRAWING NO.			REV
NAME PLATE					U 01	4-V-5801-06825 01			

CAUTION: THE INFORMATION ON THIS DOCUMENT IS THE PROPERTY OF BHARAT HEAVY ELECTRICALS LIMITED. IT MUST NOT BE USED DIRECTLY OR INDIRECTLY IN ANY WAY DETRIMENTAL TO THE INTEREST OF THE COMPANY.

REV: 01	DATE: 19.8.70	BY: [Signature]	CHECKED: [Signature]
MATERIAL CHANGED FROM ALUMINIUM TO STAINLESS STEEL THICKNESS 0.5mm WAS 1mm NOTE.5 ADDED.		OR: 15.2.71	BY: R. Mohan
QUALITY REFERENCES REMOVED		APPD: [Signature]	

SPACE FOR PUNCHING SIZE ON BRIGHT BACKGROUND.

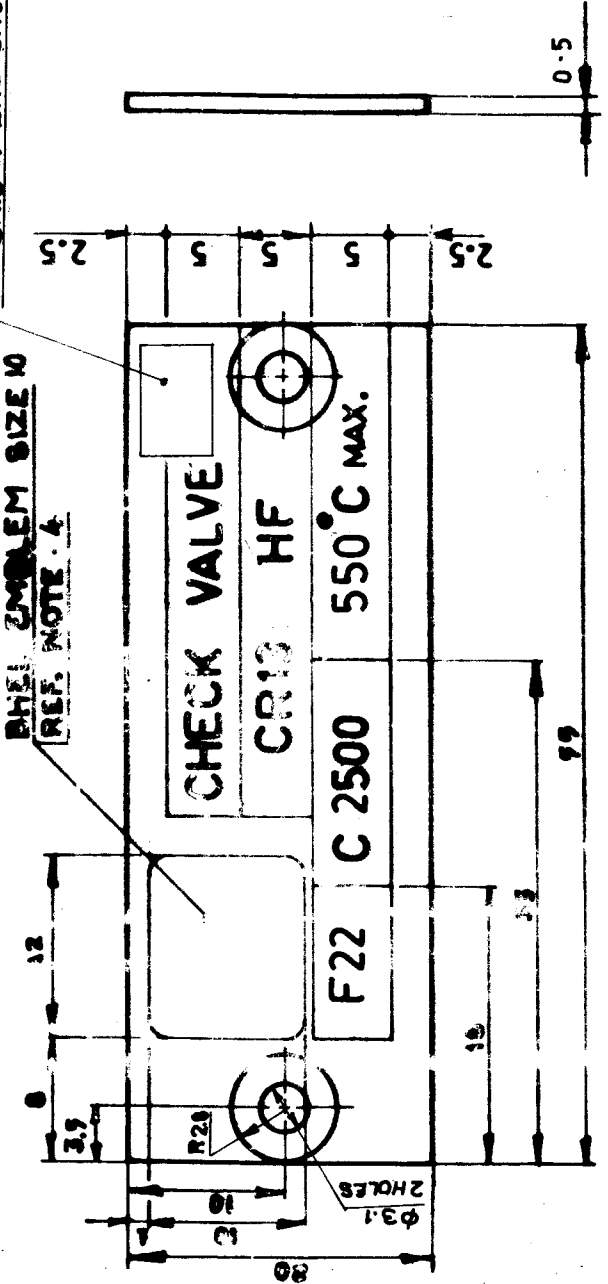

1. MATERIAL : 18-8 Cr. Ni STAINLESS STEEL.
2. THE NAME PLATE SHALL HAVE RAISED BRIGHT POLISHED LETTERS, EMBLEM ETC. ON ETCHED BLACK ENAMELLED BACKGROUND.
3. THE ENAMEL SHALL BE CRACK RESISTING SO THAT WHEN BENT, THE ENAMEL DOES NOT CRACK.
4. MONOGRAM SHALL BE BASED ON CORPORATE STANDARD No. AA 040 11 20 (LATEST REVISION)
5. FINAL THICKNESS OF THE NAME PLATE AFTER ETCHING, ENAMELLING & POLISHING SHALL NOT BE LESS THAN 0.5mm SUPPLIERS SHALL TAKE SUITABLE RAW MATERIAL THICKNESS TO MEET THE SPECIFIED FINAL THICKNESS.



	Bharat Heavy Electricals Ltd. SCALER PLANT UNIT TIRUPATI - 517 014		NAME: [Signature] SIGN: [Signature]	DATE: 15.6.89
	DESIGNED BY: [Signature]	CHECKED BY: [Signature]	APPROVED BY: [Signature]	WEIGHT (kg.): 9.003
SCALE: NTS	DRG. NO.: U 01	TITLE: NAME PLATE	DRAWING NO.: 4-V-5835-06533	REV.: 02

FOR TOLERANCES OF UNTOLERANCED DIMENSIONS DURING MANUFACTURE REFER RELEVANT QCP/QP

REV	DATE	ALTERED
		CHD & APPD

CAUTION: The information on this document is the property of BHARAT HEAVY ELECTRICALS LTD. It must not be used directly or indirectly in any way detrimental to the interest of the company.

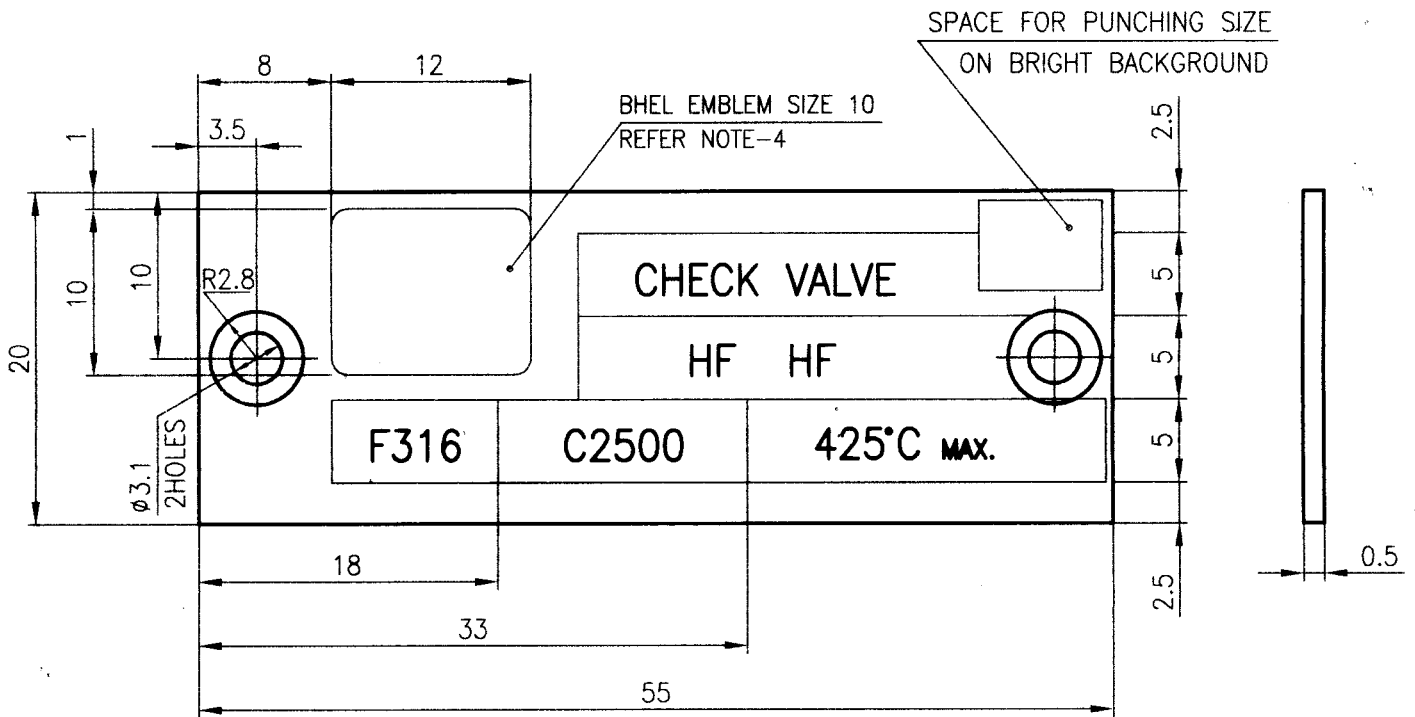

NOTES :

01. MATERIAL : 18-8 Cr. Ni. STAINLESS STEEL.
02. ALL LETTERS AND BORDERS TO BE BRIGHT POLISHED AND RAISED ON A ETCHED BLACK ENAMELLED BACKGROUND UNLESS OTHERWISE SPECIFIED.
03. THE ENAMEL SHALL BE CRACK RESISTANT, SO THAT WHEN BENT, THE ENAMEL DOES NOT CRACK.
04. MONOGRAM SHALL BE BASED ON CORPORATE STANDARD No. AA 040 11 20 (LATEST REVISION)
05. THE FINAL THICKNESS OF THE NAME PLATE AFTER ETCHING, ENAMELLING & POLISHING SHALL NOT BE LESS THAN 0.5 mm. SUPPLIERS SHALL TAKE SUITABLE RAW MATERIAL THICKNESS TO MEET THE SPECIFIED FINAL THICKNESS.

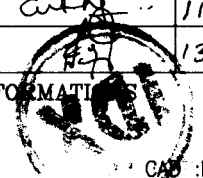
-	-	96 453 662	-	-	-	0.003	-	-	950
No. OFF	DESCRIPTION	MATL CODE	MATL SPECN	HEAT TREATMENT	SCRAP SORT	NET WT (kg)	GROSS WT (kg)	DRAWING No	ITEM No
	 BHARAT HEAVY ELECTRICALS LTD., UNIT: HIGH PRESSURE BOILER PLANT. TIRUCHIRAPALLI 620014. 365-122								
		DRN	R. MOHAN	SIGN	R. Mohan	DATE	9.9.99	NO. OF VAR	
		CHD	C.V.L.NARASIMHAM	SIGN	[Signature]	DATE	11.9.99		
		APPD	N.NAGARAJAN	SIGN	[Signature]	DATE	13.9.99		
DEPT VL			SCALE	WEIGHT (KG).	REFERENCE INFORMATION				NO. OF ITEMS
CODE	320		NTS	0.003	 CAD : F426249				

TITLE	CARD CODE	DRAWING NO.	REV
NAME PLATE	U 01	4-V-5871-26249	

CAUTION: this information is confidential. It must not be used directly or indirectly in any way detrimental to the interest of the company.

REV	DATE	ALTERED: R. Mohan
01	15.3.97	CHECKED & APPD: [Signature]
DCN: FS: 595		
QUALITY REFERENCES REMOVED.		

BHEL EMBLEM SIZE: 10

REF. NOTE: 4

SPACE FOR PUNCHING
 SIZE ON BRIGHT BACKGROUND

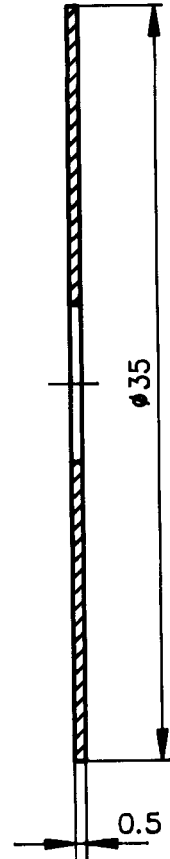
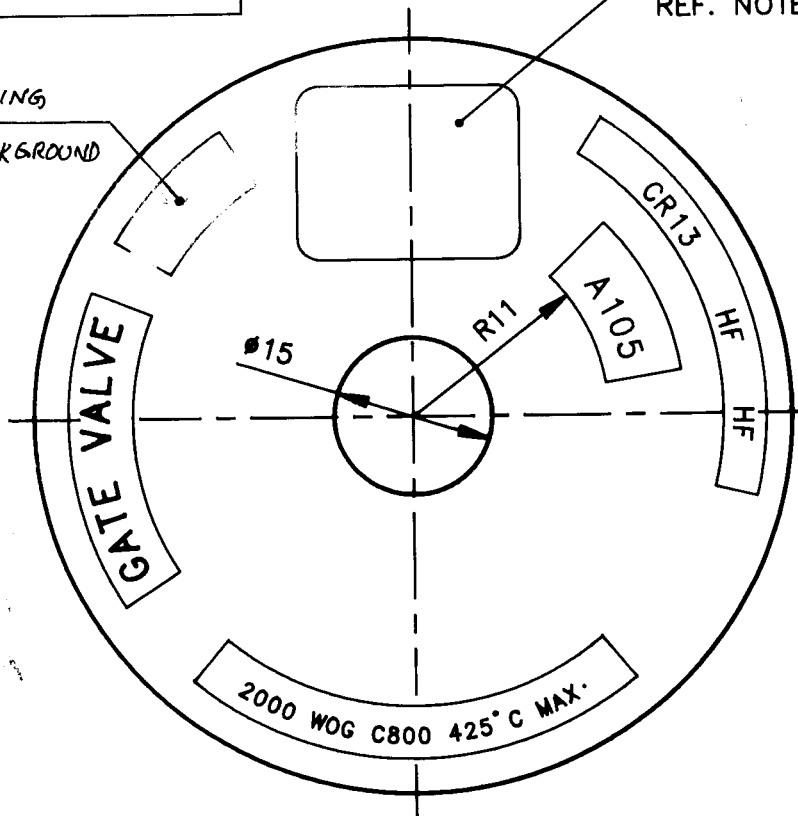

NOTES:

1. MATERIAL: 18-8 Cr. Ni STAINLESS STEEL
2. THE NAME PLATE SHALL HAVE RAISED BRIGHT POLISHED LETTERS; EMBLEM ETC. ON ETCHED BLACK ENAMELLED BACKGROUND
3. THE ENAMEL SHALL BE CRACK RESISTING SO THAT WHEN BENT THE ENAMEL DOES NOT CRACK.
4. MONOGRAM SHALL BE BASED ON CORPORATE STANDARD No. AA 040 11 20 (LATEST REVISION)
5. FINAL THICKNESS OF THE NAME PLATE AFTER ETCHING, ENAMELLING & POLISHING SHALL NOT BE LESS THAN 0.5mm. SUPPLIERS SHALL TAKE SUITABLE RAW MATERIAL THICKNESS TO MEET THE SPECIFIED FINAL THICKNESS.



NO OFF	DESCRIPTION	MATL CODE	MATL SPECN	HEAT TREATMENT	SCRAP SORT	NET WT (kg)	GROSS WT (kg)	DRAWING No.	ITEM No.
 BHARAT HEAVY ELECTRICALS LTD., UNIT: HIGH PRESSURE BOILER PLANT. TRUCHIRAPALLI 620014.					DRN CHD APPD	NAME R. MOHAN K. RAVICHANDRAN N. NAGARAJAN	SIGN R. Mohan [Signature] [Signature]	DATE 30.12.94 18.01.95 19.1.95	NO. OF VAR
DEPT VL	GRADE OF UNTOL DIM	SCALE		WEIGHT (KG).		REFERENCE INFORMATION			NO. OF TIMES
CODE 320	C/M/F	NTS		0.002		COMP. CODE: 964565160000 CAD: F406861			
TITLE					CARD CODE	DRAWING NO.			REV
NAME PLATE					U 01	4-V-5903-06861			01

FOR TOLERANCES OF UNTOLERANCED DIMENSIONS DURING MANUFACTURE REFER RELEVANT OCP/OP

ALL DIMENSIONS ARE IN MILLIMETRES

REV 01	DATE 15.3.97	ALTERED : R. Mohan	CHECKED & APPD:
DCN:FSI 0595			
QUALITY REFERENCES REMOVED.			

CAUTION: The information on this document is the property of BHARAT HEAVY ELECTRICALS LTD. It must not be used directly or indirectly in any way detrimental to the interest of the company.

BHEL EMBLEM SIZE: 10

REF. NOTE: 4

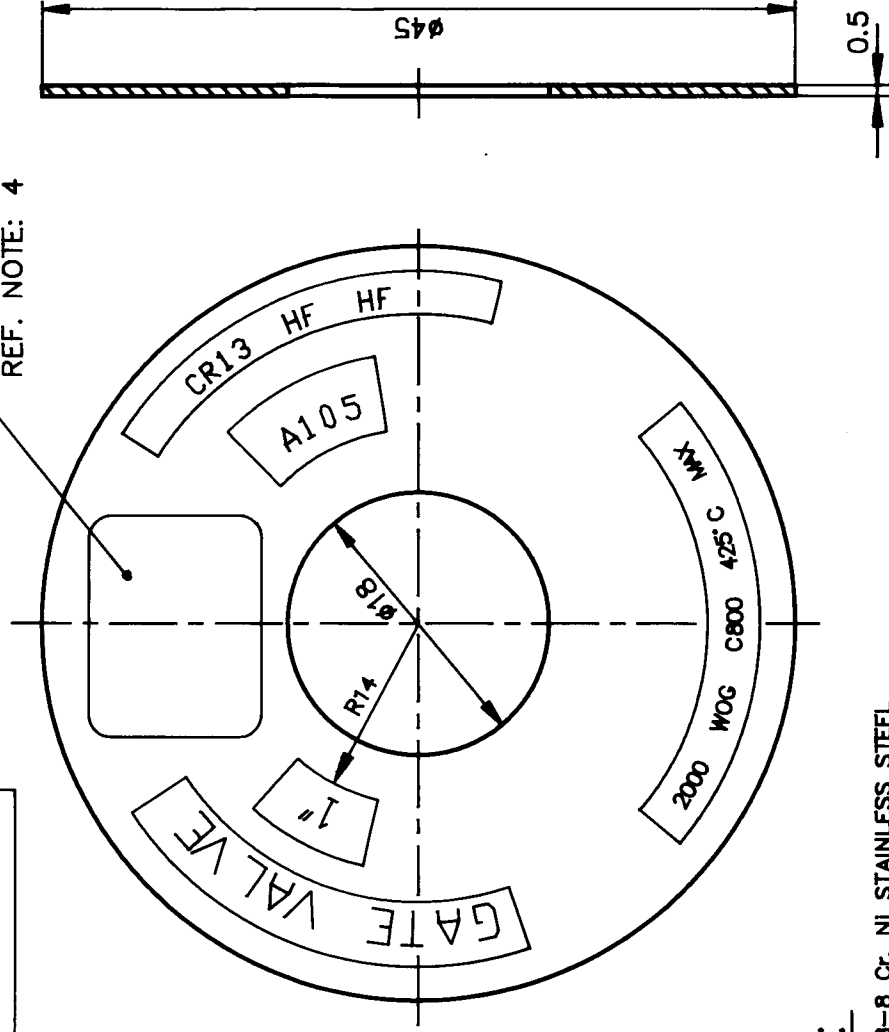

NOTES:

1. MATERIAL: 18-8 CR. NI STAINLESS STEEL
2. THE NAME PLATE SHALL HAVE RAISED BRIGHT POLISHED LETTERS, EMBLEM ETC. ON ETCHED BLACK ENAMELLED BACKGROUND
3. THE ENAMEL SHALL BE CRACK RESISTING SO THAT WHEN BENT THE ENAMEL DOES NOT CRACK.
4. MONOGRAM SHALL BE BASED ON CORPORATE STANDARD No. AA 040 11 20 (LATEST REVISION)
5. FINAL THICKNESS OF THE NAME PLATE AFTER ETCHING, ENAMELLING & POLISHING SHALL NOT BE LESS THAN 0.5mm.
6. SUPPLIERS SHALL TAKE SUITABLE RAW MATERIAL THICKNESS TO MEET THE SPECIFIED FINAL THICKNESS.



NO OFF	DESCRIPTION	MATL CODE	MATL SPECM	HEAT TREATMENT	SCRAP SORT	NET WT (KG)	GROSS WT (KG)	DRAWING NO.	ITEM No	NO. OF VAR
	BHARAT HEAVY ELECTRICALS LTD., UNIT: HIGH PRESSURE BOILER PLANT. TIRUCHIRAPALLI 620014.			DRN	M.SRINIVASAN	NAME	M.SRINIVASAN	SIGN	DATE	08.10.94
				CHD	K.RAVICHANDRAN				08.10.94	08.10.94
				APPD	M.NAGARAJAN				08.10.94	08.10.94
DEPT VL CODE 320	GRADE OF UNTOL.DIM C/M/T	SCALE NTS	WEIGHT (KG) 0.003	REFERENCE INFORMATION COMPONENT CODE : 96456 4910000 CAD : F406820						
TITLE NAME PLATE										REV 01
DRAWING NO. 4-V-5904-06820										

CAUTION: The information on this document is the property of Bharat Heavy Electricals Ltd. It must not be used directly or indirectly in any way detrimental to the interest of the company.

REV 01	DATE 15.3.97	ALTERED : R. Mohan CHECKED & APPD: <i>[Signature]</i>
DCN: FS: 0595	QUALITY REFERENCES REMOVED	

BHEL EMBLEM SIZE: 10
 REF. NOTE: 4

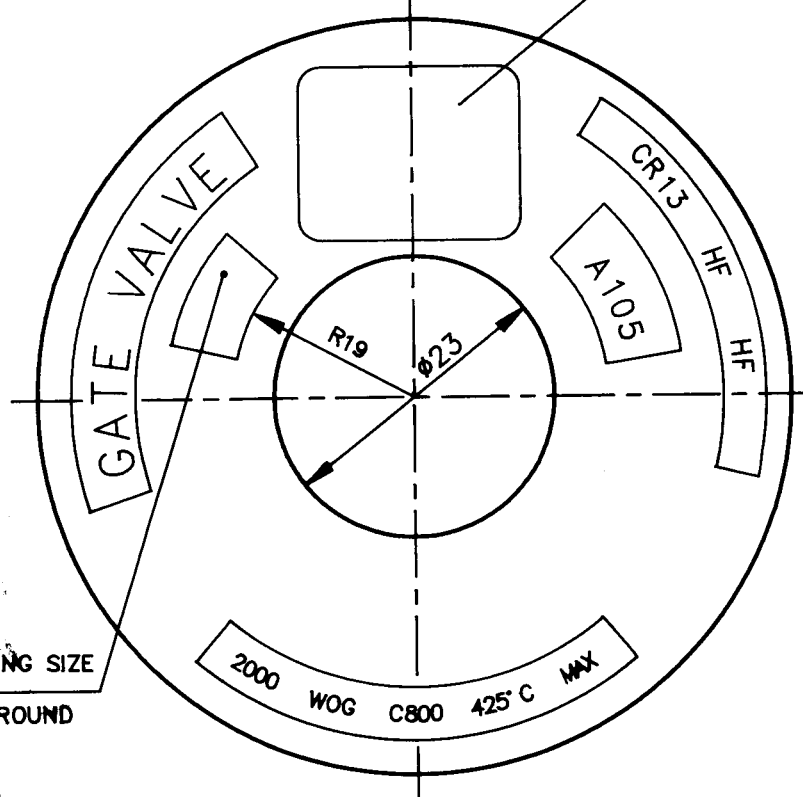

NOTES:

1. MATERIAL: 18-8 Cr. Ni STAINLESS STEEL
2. THE NAME PLATE SHALL HAVE RAISED BRIGHT POLISHED LETTERS, EMBLEM ETC. ON ETCHED BLACK ENAMELLED BACKGROUND
3. THE ENAMEL SHALL BE CRACK RESISTING SO THAT WHEN BENT THE ENAMEL DOES NOT CRACK.
4. MONOGRAM SHALL BE BASED ON CORPORATE STANDARD No. AA 040 11 20 (LATEST REVISION)
5. FINAL THICKNESS OF THE NAME PLATE AFTER ETCHING, ENAMELLING & POLISHING SHALL NOT BE LESS THAN 0.5mm. SUPPLIERS SHALL TAKE SUITABLE RAW MATERIAL THICKNESS TO MEET THE SPECIFIED FINAL THICKNESS.



NO OFF	DESCRIPTION	MATL CODE	MATL SPECN	HEAT TREATMENT	SCRAP SORT	NET WT (kg)	GROSS WT (kg)	DRAWING No	ITEM No
BHARAT HEAVY ELECTRICALS LTD., UNIT: HIGH PRESSURE BOILER PLANT, TIRUCHIRAPALLI 620014.					DRN	NAME	SIGN	DATE	NO. OF VAR
					CHD	M.SRINIVASAN	<i>[Signature]</i>	18.11.94	
					APPD	K.RAVICHANDRAN	<i>[Signature]</i>	18.11.94	
						N.NAGARAJAN	<i>[Signature]</i>	18.11.94	
DEPT VL	GRADE OF UNTOL DIM	SCALE		WEIGHT (KG).		REFERENCE INFORMATION			NO. OF TIMES
CODE 320	C / M / T	NTS		0.003		COMP. CODE: 96 456 499 0000 5906S100 CAD : F406849			
TITLE					CARD CODE	DRAWING NO.			REV
NAME PLATE					U 01	4-V-5906-06849			10

CAUTION: The information on this document is the property of BHARAT HEAVY ELECTRICALS LTD. It must not be used directly or indirectly in any way detrimental to the interest of the company.

REV	DATE	ALTERED:-
01	15.3.97	R. Mohan.
CHD & APPD:		<i>[Signature]</i>

DCN: FS: 0595

QUALITY REFERENCES REMOVED.

BHEL EMBLEM SIZE: 10
 REF. NOTE: 4

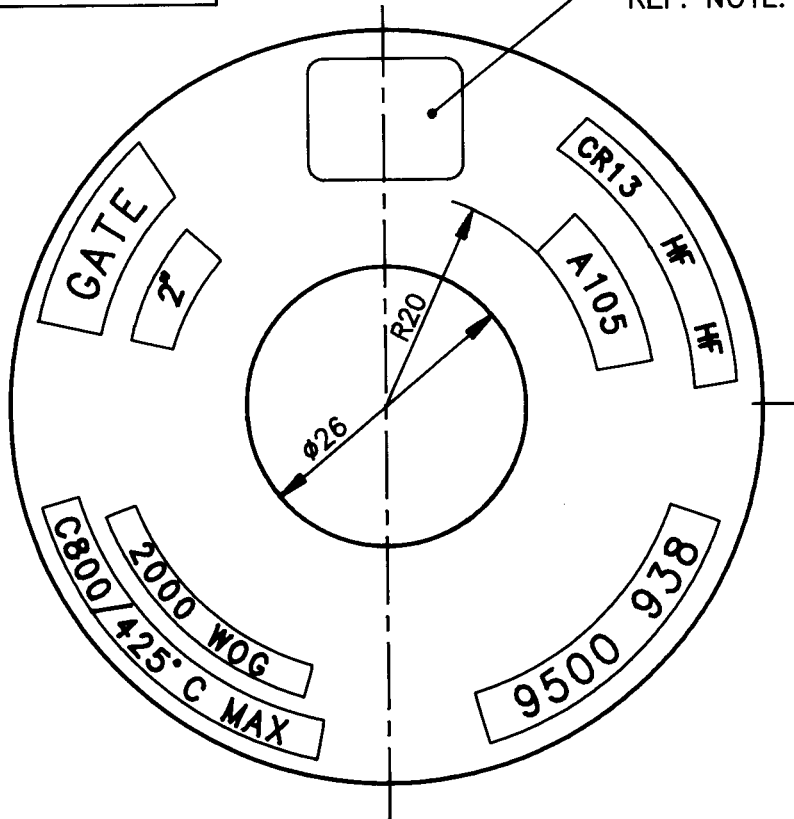

NOTES:

1. MATERIAL: 18-8 Cr. Ni STAINLESS STEEL
2. THE NAME PLATE SHALL HAVE RAISED BRIGHT POLISHED LETTERS, EMBLEM ETC. ON ETCHED BLACK ENAMELLED BACKGROUND
3. THE ENAMEL SHALL BE CRACK RESISTING SO THAT WHEN BENT THE ENAMEL DOES NOT CRACK.
4. MONOGRAM SHALL BE BASED ON CORPORATE STANDARD No. AA 040 11 20 (LATEST REVISION)
5. FINAL THICKNESS OF THE NAME PLATE AFTER ETCHING, ENAMELING & POLISHING SHALL NOT BE LESS THAN 0.5mm. SUPPLIERS SHALL TAKE SUITABLE RAW MATERIAL THICKNESS TO MEET THE SPECIFIED FINAL THICKNESS.



-	-	-	-	-	-	-	-	-	-
NO OFF	DESCRIPTION	MATL CODE	MATL SPECN	HEAT TREATMENT	SCRAP SORT	NET WT (KG)	GROSS WT (KG)	DRAWING No	ITEM No
BHARAT HEAVY ELECTRICALS LTD. UNIT: HIGH PRESSURE BOILER PLANT. TIRUCHIRAPALLI 620014.					DRN	NAME	SIGN	DATE	NO. OF VAR
					CHD	R. MOHAN	<i>R. Mohan</i>	16.11.95	
					APPD	K.S. RAMAN	<i>[Signature]</i>	17.11.95	
APPD	N. NAGARAJAN	<i>[Signature]</i>	17.11.95						
DEPT VL			SCALE	WEIGHT (KG).	REFERENCE INFORMATIONS				NO. OF ITEMS
CODE 320			NTS	0.006	COMP. CODE: 964566120000 5907S100 CAD: F406914				
TITLE					CARD CODE	DRAWING NO.			REV
NAME PLATE					U 01	4-V-5907-06914			01

CAUTION: THE INFORMATION ON THIS DOCUMENT IS THE PROPERTY OF BHARAT HEAVY ELECTRICALS LIMITED. IT MUST NOT BE USED DIRECTLY OR INDIRECTLY IN ANY WAY DETRIMENTAL TO THE INTEREST OF THE COMPANY.

TP-DG 4-V-5914-06518
CORPORATE DRG ID

REV. 01	DATE 10.8.90	CHECKED	REV. 02	DATE 15.3.97	ALTERED: R. Mohan	CHECKED & APPD: [Signature]
MATERIAL CHANGED FROM ALUMINIUM TO STAINLESS STEEL THICKNESS 0.5mm WAS 1mm NOTE .5 ADDED.			DCN: 53 0595	QUALITY REFERENCES REMOVED.		

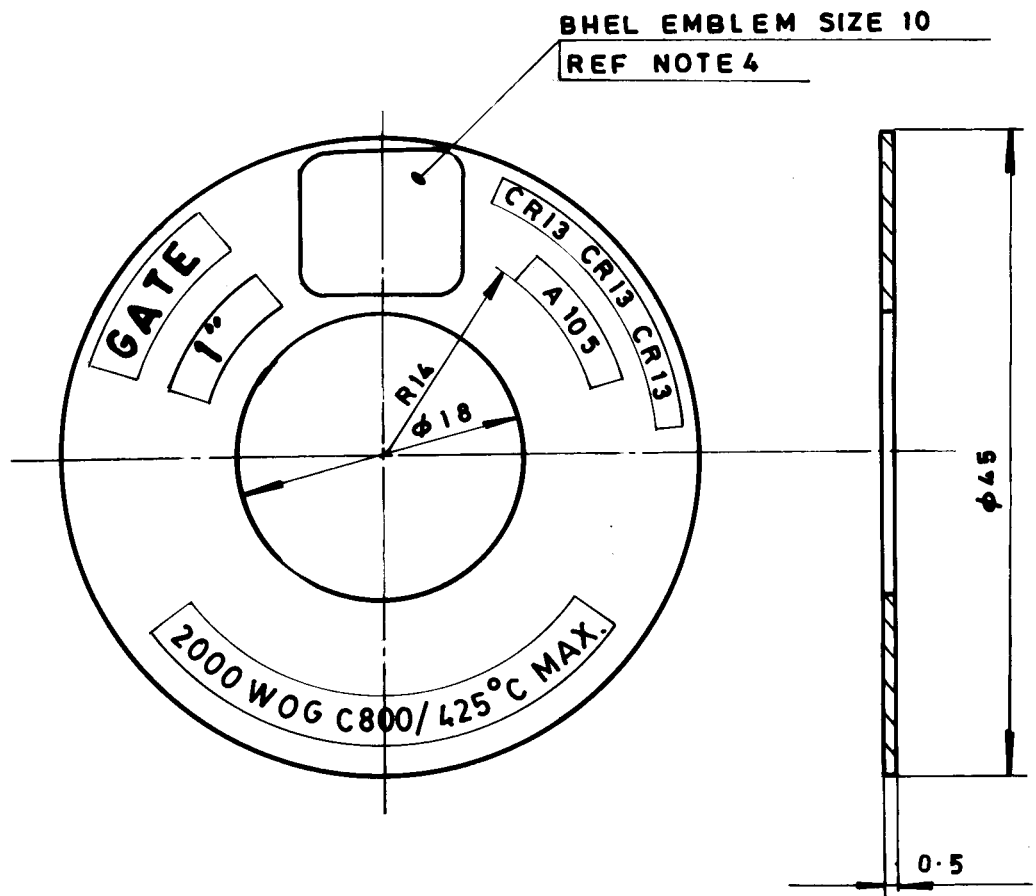

NOTES :-

1. MATERIAL : 18-8 Cr.Ni STAINLESS STEEL.
2. THE NAME PLATE SHALL HAVE RAISED BRIGHT POLISHED LETTERS, EMBLEM ETC. ON ETCHED BLACK ENAMELLED BACKGROUND.
3. THE ENAMEL SHALL BE CRACK RESISTING SO THAT WHEN BENT THE ENAMEL DOES NOT CRACK.
4. THE MONOGRAM SHALL BE BASED ON CORPORATE STANDARD NO. AA 040 11 20 (LATEST REVISION)
5. FINAL THICKNESS OF THE NAME PLATE AFTER ETCHING, ENAMELLING & POLISHING SHALL NOT BE LESS THAN 0.5mm. SUPPLIERS SHALL TAKE SUITABLE RAW MATERIAL THICKNESS TO MEET THE SPECIFIED FINAL THICKNESS.

<p>Bharat Heavy Electricals Ltd., BOILER PLANT UNIT TIRUCHIRAPALLI — 620 014</p>		DRN.	NAME	SIGN.	DATE
		CHD.	[Signature]		
		APPD.			15.3.97
DEPT.	GRADE OF UNTOL DIM.	SCALE	WEIGHT (kg.)	MATL CODE	ITEM NO.
CODE	R.M.T.E	NTS	0.003	96456018	
TITLE			CARD CODE	DRAWING NO.	REV
NAME PLATE			U 01	4_V_5914_06518	02

CAUTION: The information on this document is the property of BHARAT HEAVY ELECTRICALS LTD. It must not be used directly or indirectly in any way detrimental to the interest of the company.

REV 01	DATE 15.3.97	ALTERED : R. Mohan
	CHECKED & APPD: <i>[Signature]</i>	
DCN: FS: 0595		
QUALITY REFERENCES REMOVED.		

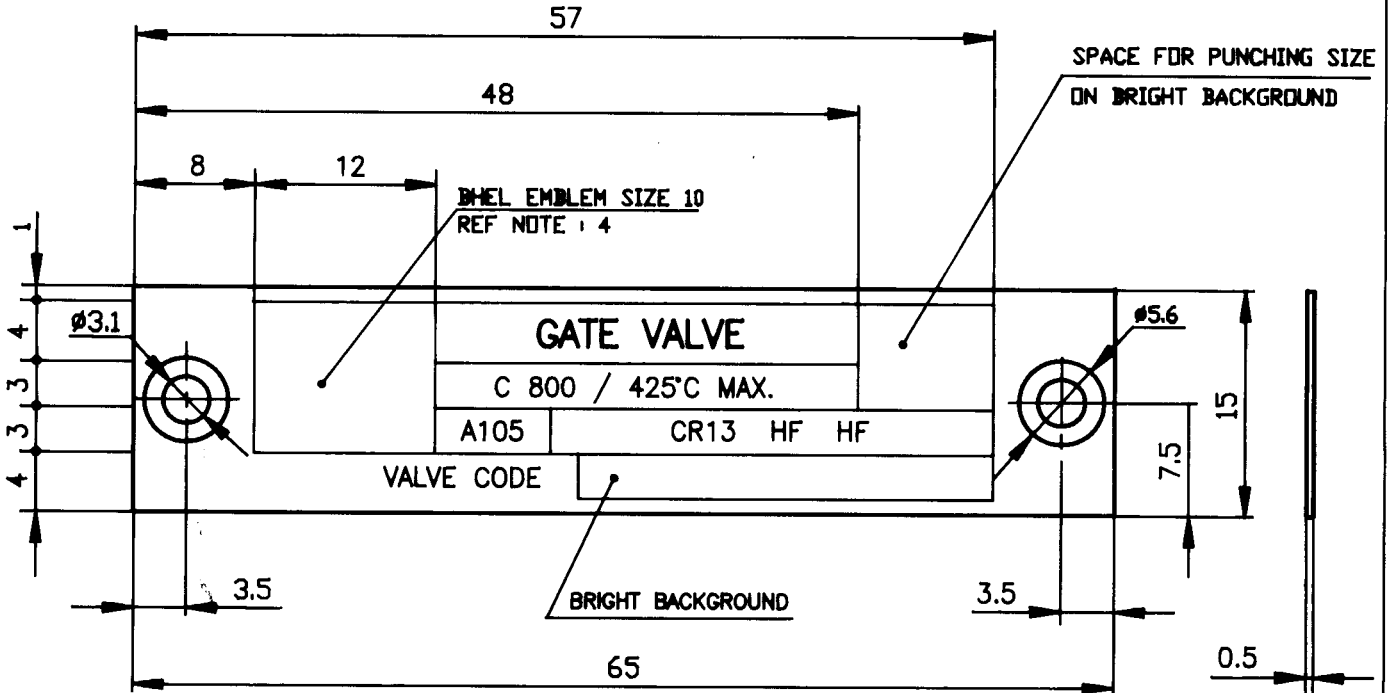

NOTES:

- MATERIAL : 18-8 Cr. Ni. STAINLESS STEEL.
- THE NAME PLATE SHALL HAVE RAISED BRIGHT POLISHED LETTERS, MONOGRAM, ETC. ON ETCHED BLACK ENAMELLED BACKGROUND.
- THE ENAMEL SHALL BE CRACK RESISTING SO THAT WHEN BENT THE ENAMEL DOES NOT CRACK.
- MONOGRAM SHALL BE BASED ON CORPORATE STANDARD No. AA 040 11 20 (LATEST REVISION)

FINAL THICKNESS OF THE NAME PLATE AFTER ETCHING, ENAMELLING & POLISHING SHALL NOT BE LESS THAN 0.5mm. SUPPLIERS SHALL TAKE SUITABLE RAW MATERIAL THICKNESS TO MEET THE SPECIFIED FINAL THICKNESS.



NO OFF	DESCRIPTION	MATL CODE	MATL SPECN	HEAT TREATMENT	SCRAP SORT	NET WT (KG)	GROSS WT (KG)	DRAWING No	ITEM No
	 BHARAT HEAVY ELECTRICALS LTD. UNIT: HIGH PRESSURE BOILER PLANT. TIRUCHIRAPALLI 620014.								
		DRN	NAME	SIGN	DATE	NO. OF VAR			
		CHD	M.SRINIVASAN	<i>[Signature]</i>	08.10.94				
	APPD	K.RAVICHANDRAN	<i>[Signature]</i>	08.10.94					
			N.NAGARAJAN.	<i>[Signature]</i>	08.10.94				
DEPT VL	GRADE OF UNTOL DIM	SCALE	WEIGHT (KG).	REFERENCE INFORMATION			NO. OF TRIMS		
CODE 320	C/M/J	N T S	0.003	COMPONENT CODE : 96456490000 CAD : F406819					
TITLE				CARD CODE	DRAWING NO.		REV		
NAME PLATE				U 01	4-V-5928-06819		01		

REV 01	DATE 18.07.90	CHECKED	U. S.
REV 02	DATE 15.3.97	CHECKED & APPD:	R. Mohan
DCN:FS 0595	MATERIAL CHANGED FROM ALUMINIUM TO STAINLESS STEEL THICKNESS 0.5mm WAS 1mm NOTE 5 ADDED.		
QUALITY REFERENCES REMOVED.			

CAUTION: THE INFORMATION ON THIS DOCUMENT IS THE PROPERTY OF BHARAT HEAVY ELECTRICALS LIMITED. IT MUST NOT BE USED DIRECTLY OR INDIRECTLY IN ANY WAY DETRIMENTAL TO THE INTEREST OF THE COMPANY.

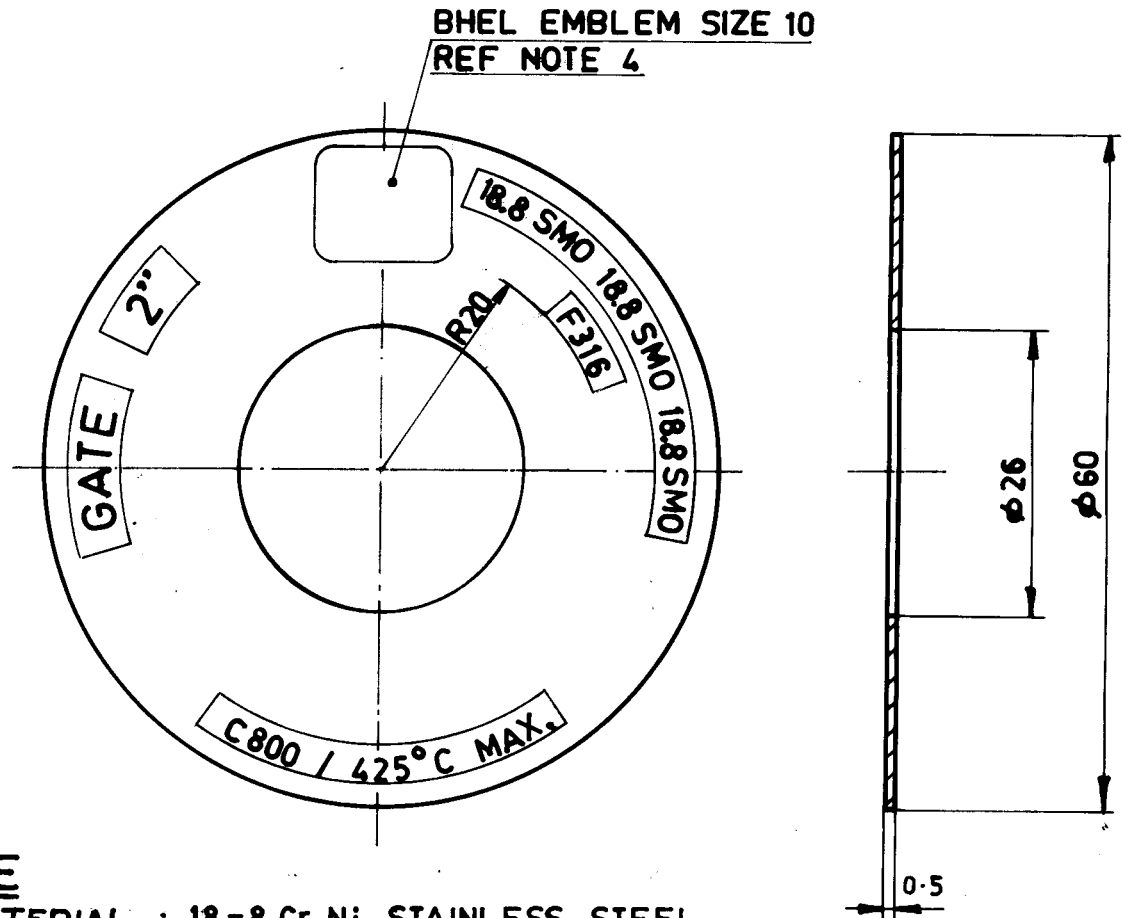

NOTE

1. MATERIAL : 18-8 Cr.Ni STAINLESS STEEL
2. THE NAME PLATE SHALL HAVE RAISED BRIGHT POLISHED LETTERS, EMBLEM ETC. ON ETCHED BLACKENAMELLED BACKGROUND
3. THE ENAMEL SHALL BE CRACK RESISTING SO THAT WHEN BENT THE ENAMEL DOES NOT CRACK
4. THE MONOGRAM SHALL BE BASED ON CORPORATE STANDARD NO. AA 040 11 20
5. FINAL THICKNESS OF THE NAME PLATE AFTER ETCHING, ENAMELLING & POLISHING SHALL NOT BE LESS THAN 0.5mm. SUPPLIERS SHALL TAKE SUITABLE RAW MATERIAL THICKNESS TO MEET THE SPECIFIED FINAL THICKNESS.

<p>Bharat Heavy Electricals Ltd., BOILER PLANT UNIT TIRUCHIRAPALLI — 620 014</p>		NAME	SIGN.	DATE	
		DRN. P. JAYARAMAN	P. Jayaraman		
		CHD. U. S.		13.6.89	
APPD.					
DEPT	GRADE OF UNTOL. DIM. C/M/F	SCALE	WEIGHT (kg.)	REF. TO ASSY./OLD DRG. / MATL. CODE	ITEM NO.
		NTS	0.006	96 456 024	
TITLE			CARD CODE	DRAWING NO.	REV.
NAME PLATE			U 01	4 - V - 5937 - 06524	02

REV. 01	DATE 15.3.97	ALTERED R. Mo. Han
18-8-90	CHECKED	CHECKED & APPD: Dal
DCN: 0595	QUALITY REFERENCES REMOVED.	

MATERIAL CHANGED FROM ALUMINIUM TO STAINLESS STEEL THICKNESS 0.5mm 1mm NOTE 5. ADDED.

CAUTION: THE INFORMATION ON THIS DOCUMENT IS THE PROPERTY OF BHARAT HEAVY ELECTRICALS LIMITED. IT MUST NOT BE USED DIRECTLY OR INDIRECTLY IN ANY WAY DETRIMENTAL TO THE INTEREST OF THE COMPANY.

SPACE FOR PUNCHING SIZE ON BRIGHT BACKGROUND

BHEL EMBLEM SIZE : 10
REFER NOTE : 4

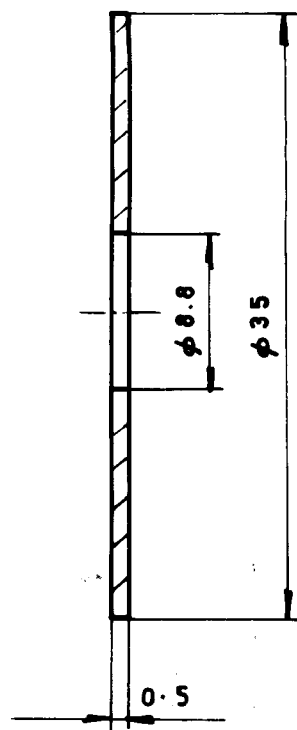
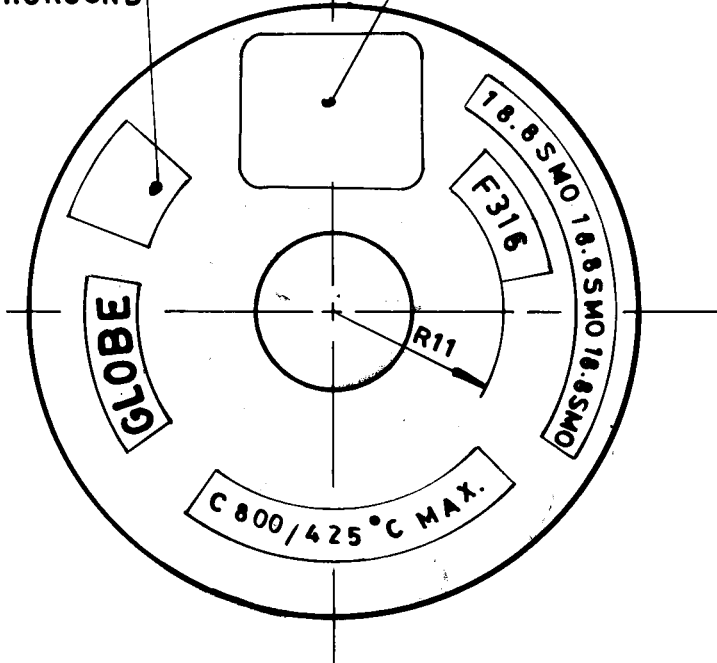

NOTE:-

1. MATERIAL : 18-8 Cr.Ni STAINLESS STEEL.
2. THE NAME PLATE SHALL HAVE RAISED BRIGHT POLISHED LETTERS, EMBLEM ETC. ON ETCHED BLACK ENAMELLE BACKGROUND.
3. THE ENAMEL SHALL BE CRACK RESISTING SO THAT WHEN BENT. THE ENAMEL DOES NOT CRACK
4. MONOGRAM SHALL BE BASED ON CORPORATE STANDARD No. AA 040 11 20 (LATEST REVISION)
5. FINAL THICKNESS OF THE NAMEPLATE AFTER ETCHING, ENAMELLING & POLISHING SHALL NOT BE LESS THAN 0.5mm. SUPPLIERS SHALL TAKE SUITABLE RAW MATERIAL THICKNESS TO MEET THE SPECIFIED FINAL THICKNESS.

VARIANT NO.	DESCRIPTION	STD.	9 6 456 005	A I C	UNIT	UNIT WT.
			MATL. CODE			DI
			MATL. SPEC.			



		Bharat Heavy Electricals Ltd., BOILER PLANT UNIT TIRUCHIRAPALLI - 620 014		NAME DRN. <i>M. J.</i>	SIGN. <i>[Signature]</i>	DATE 15.6.89
DEPT.	GRADE OF UNTOL. DIM.	SCALE	WEIGHT (kg.)	REF. TO ASSY./OLD DRG.	ITEM NO.	
CODE	<i>[Symbol]</i>	. N T S	0.00 2			
TITLE			CARD CODE	DRAWING NO.		REV.
NAME PLATE			U 01	4-V-5938-06508		02

FOR TOLERANCES OF UNTOLERANCED DIMENSIONS DURING MANUFACTURE REFER RELEVANT QCP/QP

ALL DIMENSIONS ARE IN MILLIMETRES.

REV	DATE	ALTERED	BY
01	15.3.97	CHD & APPD	<i>[Signature]</i>
QUALITY REFERENCES			
REMOVED			

BHEL EMBLEM SIZE: 10

REF. NOTE: 4

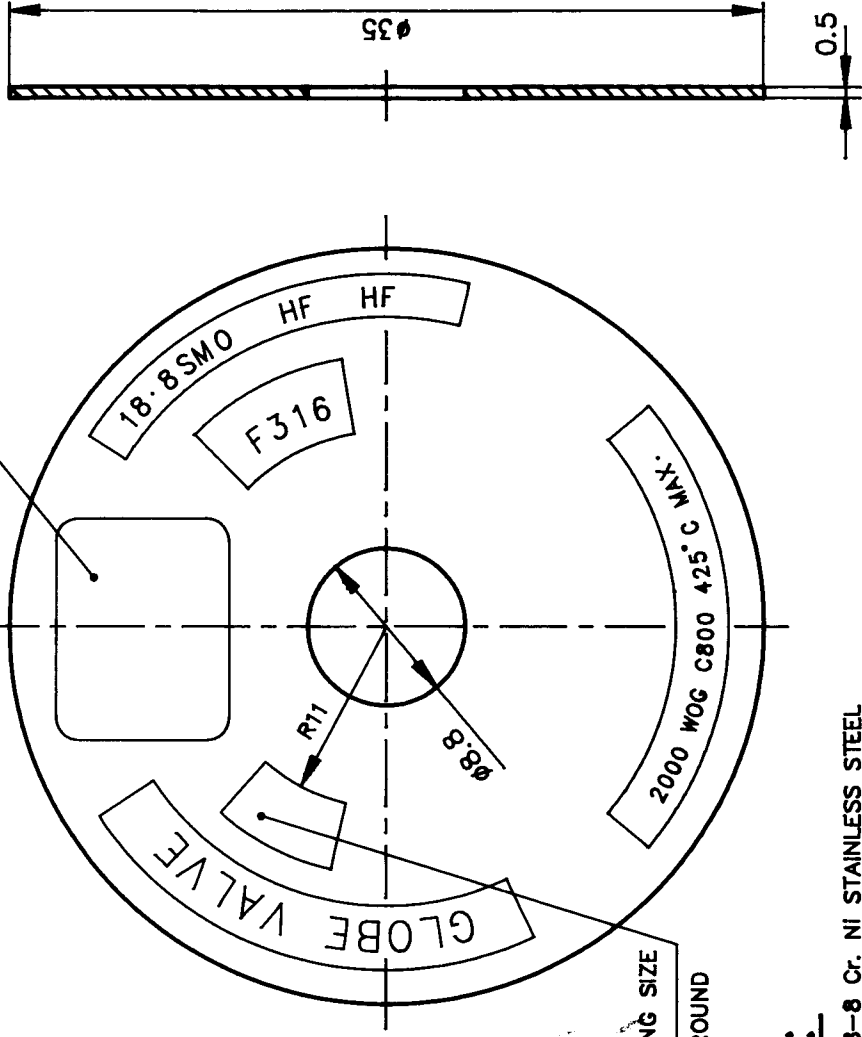

NOTES:

1. MATERIAL: 18-8 Cr. Ni STAINLESS STEEL
2. THE NAME PLATE SHALL HAVE RAISED BRIGHT POLISHED LETTERS, EMBLEM ETC. ON ETCHED BLACK ENAMELLED BACKGROUND
3. THE ENAMEL SHALL BE CRACK RESISTING SO THAT WHEN BENT THE ENAMEL DOES NOT CRACK.
4. MONOGRAM SHALL BE BASED ON CORPORATE STANDARD No. AA 040 11 20 (LATEST REVISION)
5. FINAL THICKNESS OF THE NAME PLATE AFTER ETCHING, ENAMELLING & POLISHING SHALL NOT BE LESS THAN 0.5mm. SUPPLIERS SHALL TAKE SUITABLE RAW MATERIAL THICKNESS TO MEET THE SPECIFIED FINAL THICKNESS.

NO OFF	DESCRIPTION	MATL CODE	MATL SPECN	HEAT TREATMENT	SCRAP SORT	NET WT (KG)	GROSS WT (KG)	DRAWING NO	ITEM NO
-	-	-	-	-	-	-	-	-	-
				BHARAT HEAVY ELECTRICALS LTD. UNIT: HIGH PRESSURE BOILER PLANT. TIRUCHIRAPALLI 620014.					
DEPT VL CODE 320				WEIGHT (KG) 0.002		SCALE NTS		REFERENCE INFORMATION COMP. CODE: 964565830000 CAD: F406903	
TITLE NAME PLATE				CARD CODE U 01		DRAWING NO. 4-V-5942-06903		NO. OF REV NO. OF ITMS	
								NO. OF VAR DATE 07.9.95 9.9.95 10.9.95	



REV. 01	DATE 18.8.90	CHECKED	REV. 02	DATE 15.3.97	CHECKED & APPD.
MATERIAL CHANGED FROM ALUMINIUM TO STAINLESS STEEL THICKNESS 0.5mm WAS 1mm NOTE .5 ADDED.			QUALITY REFERENCES REMOVED.		

CAUTION: THE INFORMATION ON THIS DOCUMENT IS THE PROPERTY OF BHARAT HEAVY ELECTRICALS LIMITED. IT MUST NOT BE USED DIRECTLY OR INDIRECTLY IN ANY WAY DETRIMENTAL TO THE INTEREST OF THE COMPANY.

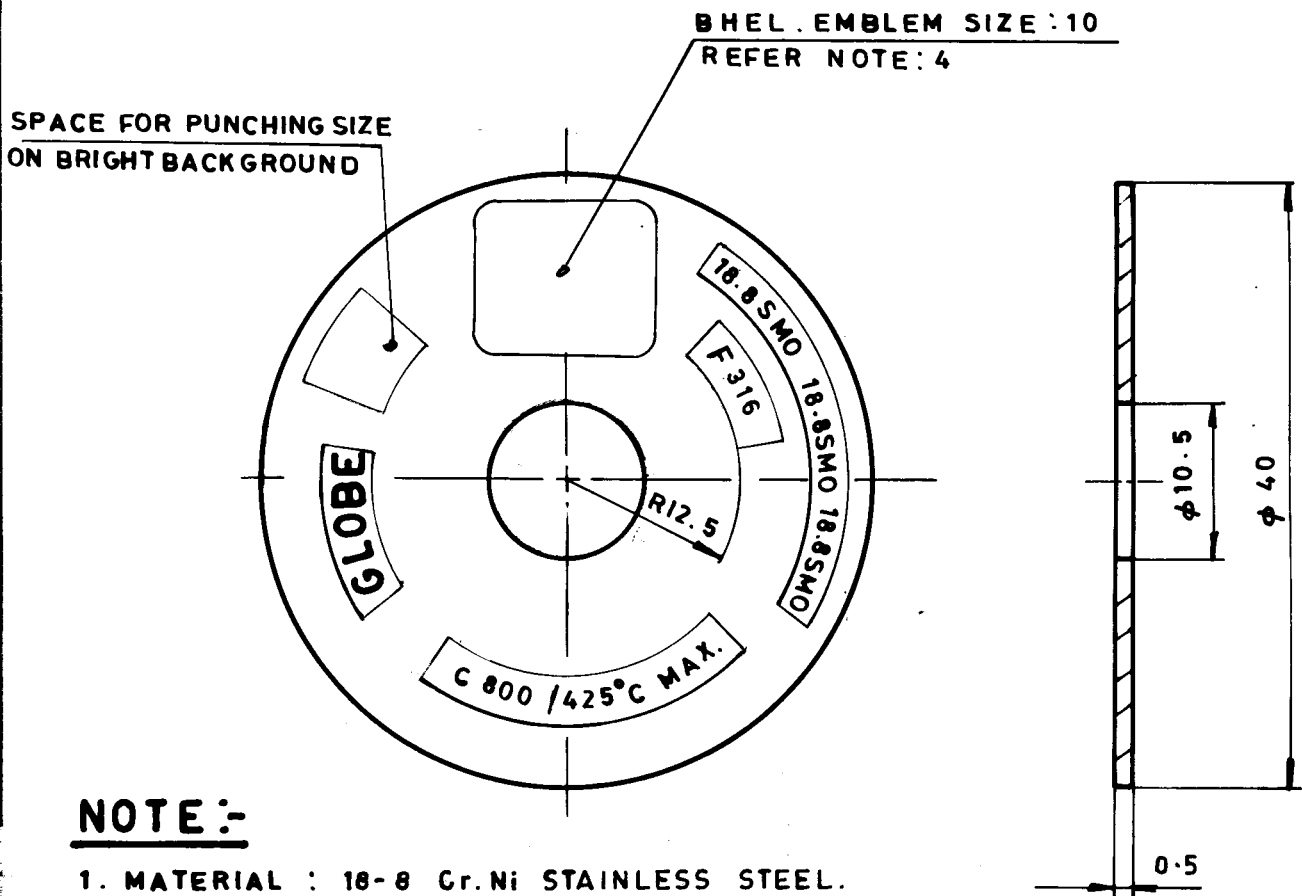

NOTE:-

1. MATERIAL : 18-8 Cr.Ni STAINLESS STEEL.
2. THE NAME PLATE SHALL HAVE RAISED BRIGHT POLISHED LETTERS, EMBLEM ETC.ON ETCHED BLACK ENAMELLED BACKGROUND
3. THE ENAMEL SHALL BE CRACK RESISTING SO THAT WHEN BENT. THE ENAMEL DOES NOT CRACK
4. MONOGRAM SHALL BE BASED ON CORPORATE STANDARD No. AA 040 11 20 (LATEST REVISION)
5. FINAL THICKNESS OF THE NAME PLATE AFTER ETCHING, ENAMELLING & POLISHING SHALL NOT BE LESS THAN 0.5mm. SUPPLIERS SHALL TAKE SUITABLE RAW MATERIAL THICKNESS TO MEET THE SPECIFIED FINAL THICKNESS.

VARIANT NO.	STD.	96 456 006	UNIT WT.
		MATL. CODE	
		MATL. SPEC.	DI
			QTY.

		Bharat Heavy Electricals Ltd., BOILER PLANT UNIT TIRUCHIRAPALLI - 620 014		NAME DRN. <i>M. S.</i> CHD. APPD.	SIGN. <i>[Signature]</i>	DATE 15.6.89
DEPT. VL	GRADE OF UNTOL. DIM. G/M/F	SCALE NTS	WEIGHT (kg.) 0.003	REF. TO ASSY./OLD DRG.		ITEM NO.
CODE 320						
TITLE NAME PLATE			CARD CODE U 01	DRAWING NO. 4 - V - 5943 - 06509 02		REV.

REV 01	DATE 18.8.90	CHECKED	REV 02	DATE 15.3.97	ALTERED: R. Mohan	CHECKED & APPD: [Signature]
MATERIAL CHANGED FROM ALUMINIUM TO STAINLESS STEEL THICKNESS 0.5 mm WAS 1mm NOTE .5 ADDED.			QUALITY REFERENCES REMOVED.			

CAUTION: THE INFORMATION ON THIS DOCUMENT IS THE PROPERTY OF BHARAT HEAVY ELECTRICALS LIMITED. IT MUST NOT BE USED DIRECTLY OR INDIRECTLY IN ANY WAY DETRIMENTAL TO THE INTEREST OF THE COMPANY.

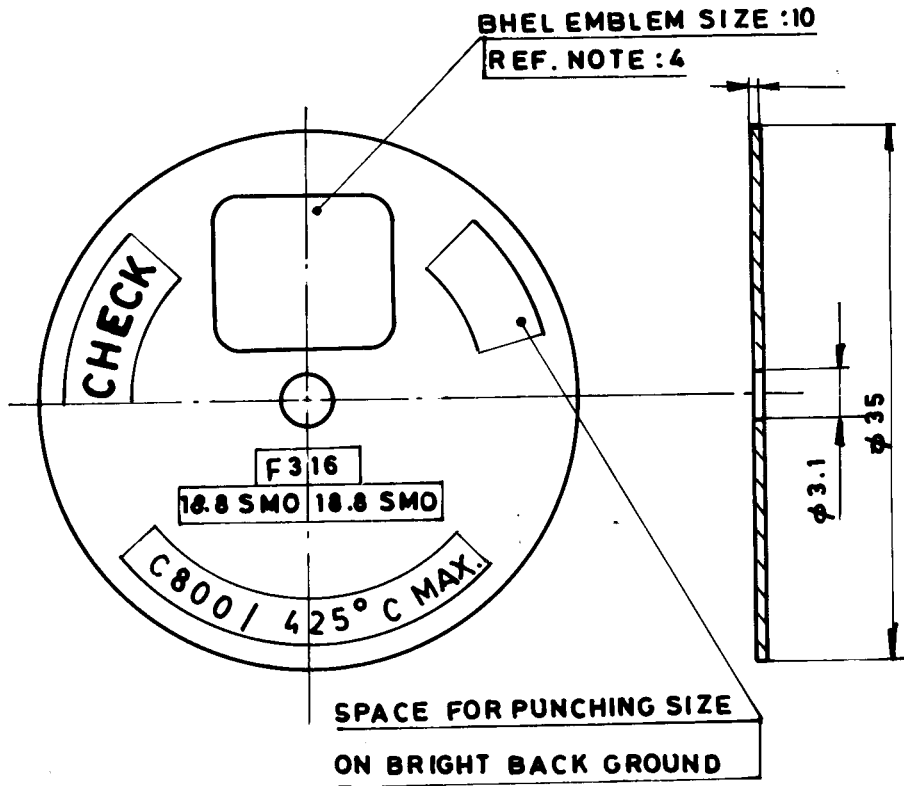

NOTE:-

1. MATERIAL:- 18-8 Cr.Ni STAINLESS STEEL.
2. THE NAME PLATE SHALL HAVE RAISED BRIGHT POLISHED LETTERS, EMBLEM ETC. ON ETCHED BLACK ENAMELLED BACKGROUND
3. THE ENAMEL SHALL BE CRACK RESISTING SO THAT WHEN BENT, THE ENAMEL DOES NOT CRACK.
4. MONOGRAM SHALL BE BASED ON CORPORATE STANDARD No. AA 040 11 20 (LATEST REVISION)
5. FINAL THICKNESS OF THE NAME PLATE AFTER ETCHING, ENAMELLING & POLISHING SHALL NOT BE LESS THAN 0.5mm. SUPPLIERS SHALL TAKE SUITABLE RAW MATERIAL THICKNESS TO MEET THE SPECIFIED FINAL THICKNESS.



		Bharat Heavy Electricals Ltd., BOILER PLANT UNIT TIRUCHIRAPALLI — 620 014			DRN.	NAME	SIGN.	DATE
DEPT. VL		GRADE OF UNTOL. DIM. G/M/F		SCALE	WEIGHT (kg.)	MATL CODE		ITEM NO.
CODE 320				NTS	0.003	96 456 008		
TITLE				CARD CODE	DRAWING NO.			REV
NAME PLATE				U 01	4_V_5946_06511			02

CAUTION : THE INFORMATION OF THIS DOCUMENT IS THE PROPERTY OF BHARAT HEAVY ELECTRICALS LIMITED IT MUST NOT BE USED DIRECTLY OR INDIRECTLY IN ANY WAY DETRIMENTAL TO THE INTEREST OF THE COMPANY.

REV: 5955-06698
 DRAWN BY: R. Mohan
 CHECKED & APPD: [Signature]
 ZONE: QUALITY REFERENCES REMOVED.
 DCN: FS: 0595

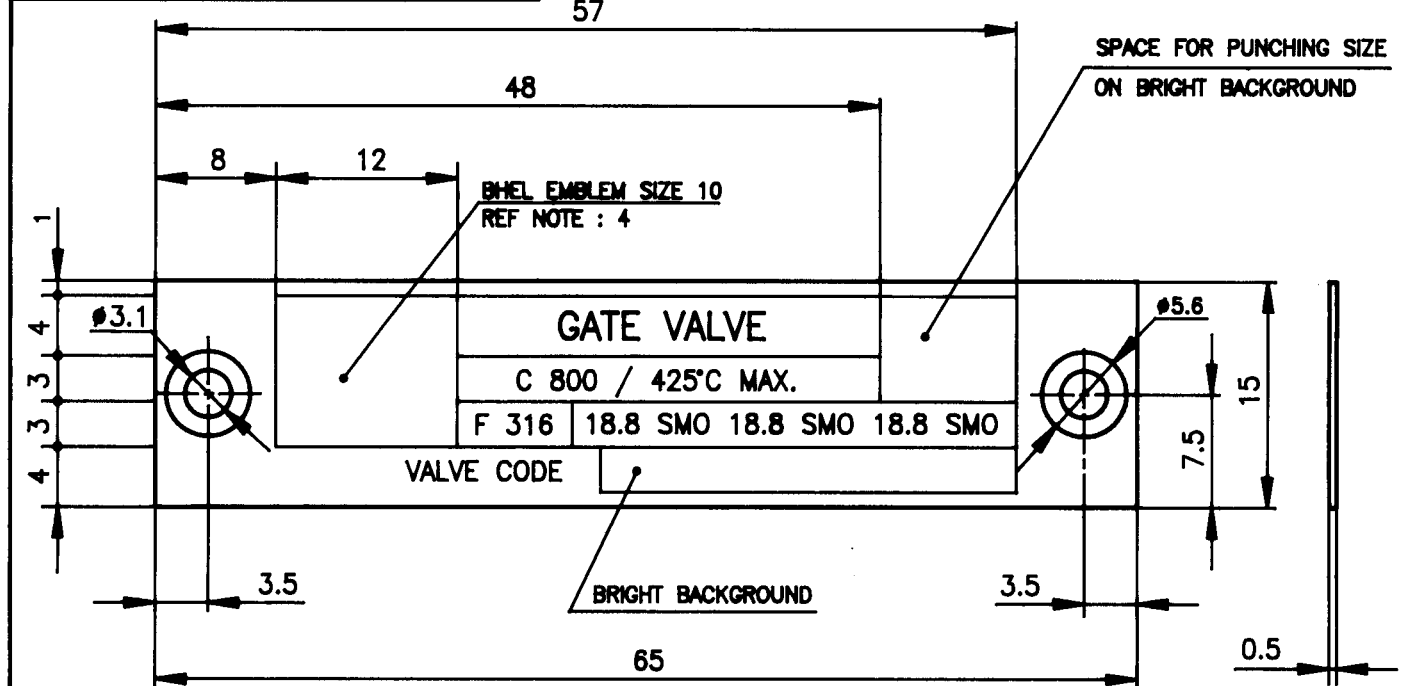

NOTES:

1. MATERIAL : 18-8 Cr. Ni. STAINLESS STEEL.
2. THE NAME PLATE SHALL HAVE RAISED BRIGHT POLISHED LETTERS, MONOGRAM, ETC. ON ETCHED BLACK ENAMELLED BACKGROUND.
3. THE ENAMEL SHALL BE CRACK RESISTING SO THAT WHEN BENT THE ENAMEL DOES NOT CRACK.
4. MONOGRAM SHALL BE BASED ON CORPORATE STANDARED No. AA 040 11 20 (LATEST REVISION)
5. FINAL THICKNESS OF THE NAME PLATE AFTER ETCHING, ENAMELLING & POLISHING SHALL NOT BE LESS THAN 0.5mm. SUPPLIERS SHALL TAKE SUITABLE RAW MATERIAL THICKNESS TO MEET THE SPECIFIED FINAL THICKNESS.

SL No	DESCRIPTION	MATL CODE	MATL SPECN	HEAT TREATMENT	SCRAP SORT	NET WT (kg)	GROSS WT (kg)	COMP CODE	ITEM No
								DRAWING No	

CAD : F406898

	BHARAT HEAVY ELECTRICALS LTD., BOILER PLANT UNIT, TIRUCHIRAPALLI-620 014.				DRAWN M.SRINIVASAN 14.9.92	DATE 21.9.92
					CHECKED N.P.ESWAR.	21.9.92
					APPROVED N.NAGARAJAN.	21.9.92
DEPT. VL 320	GRADE OF PNTOL DIM G/M/F	FIRST ANGLE 	SCALE N T S	WEIGHT (kg) 0.003	COMP CODE / REF 96 456 220	
NAME PLATE				DRG No.	4-V-5955-06698	
					REVISION 10	

CAUTION THE INFORMATION ON THIS DOCUMENT IS THE PROPERTY OF BHARAT HEAVY ELECTRICALS LTD IT MUST NOT BE USED DIRECTLY OR INDIRECTLY IN ANY WAY DETRIMENTAL TO THE INTEREST OF THE COMPANY.

REV 02	DATE	ALTERED
		CHECKED

01 0.5.77 CHECKED YAPPD: WJ.

HOLES LOCATION SHOWN.
DCN. NO. SV: 0553

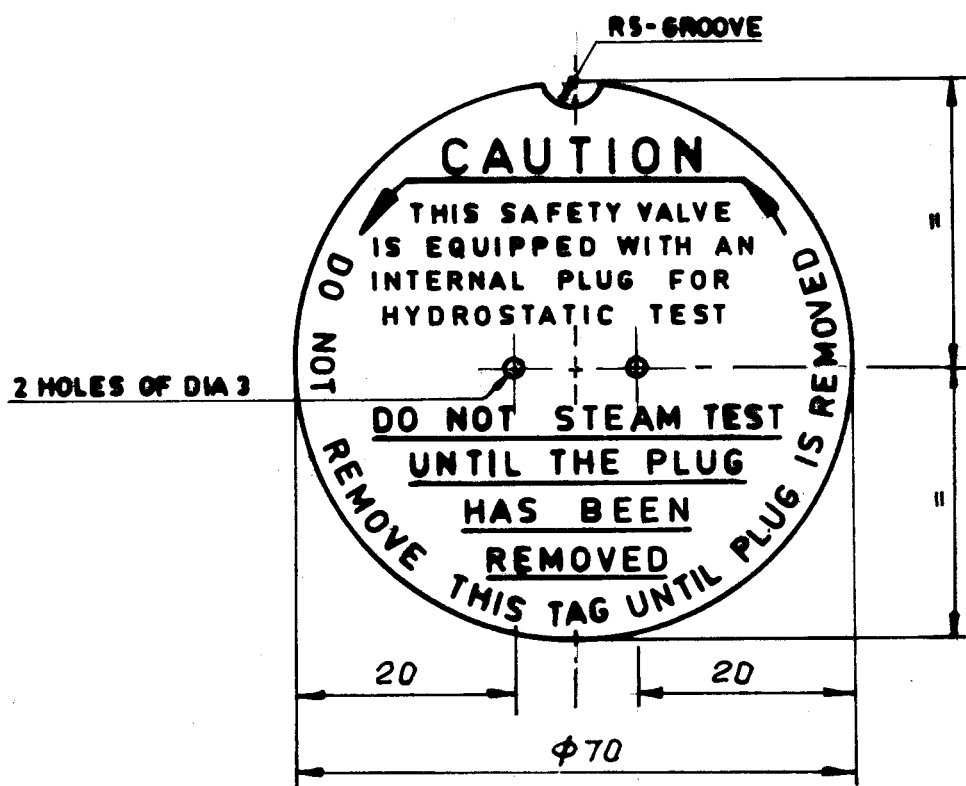

NOTE

- INSTRUCTIONS SHOULD BE PRINTED IN RED COLOUR WITH WHITE BACKGROUND

MICROFILMED ON
ROLL 00523 FRAME 3810

SH. 0.63 X φ70	96415041	13513 Gr. D	-	10	0.02	-	196	
No. OFF	DESCRIPTION	MATL. CODE	FINAL MATL.	HEAT TREATMENT	SCRAP SORT	NET Wt (kg)	GROSS Wt (kg)	ITEM No.



BHARAT HEAVY ELECTRICALS LIMITED
BOILER PLANT UNIT, TIRUCHIRAPALLI-620014

DEPT YL	CODE 340	SCALE N.T.S	WEIGHT (kg.) -
TITLE CAUTION TAG			
DRAWN T.R	NAME V.R	SIGN [Signature]	DATE 20-8-79
CHECKED			20-8-79
APPROVED JA			20-8-79

DIMENSIONS TO BE CONTROLLED WITHIN LIMITS AS SHOWN. MACHINING TOLERANCE ± 0.25 mm. UNLESS OTHERWISE SHOWN NON-MACHINING TOLERANCE ±

4 DRAWING NO. 4-V-7000-10046 01
CARD CODE
16 REV 17

REV 01	ALTERED	DATE	ALTERED
	CHECKED		CHECKED

CAUTION THE INFORMATION ON THIS DOCUMENT IS THE PROPERTY OF BHARAT HEAVY ELECTRICALS LTD IT MUST NOT BE USED DIRECTLY OR INDIRECTLY IN ANY WAY DETRIMENTAL TO THE INTEREST OF THE COMPANY.

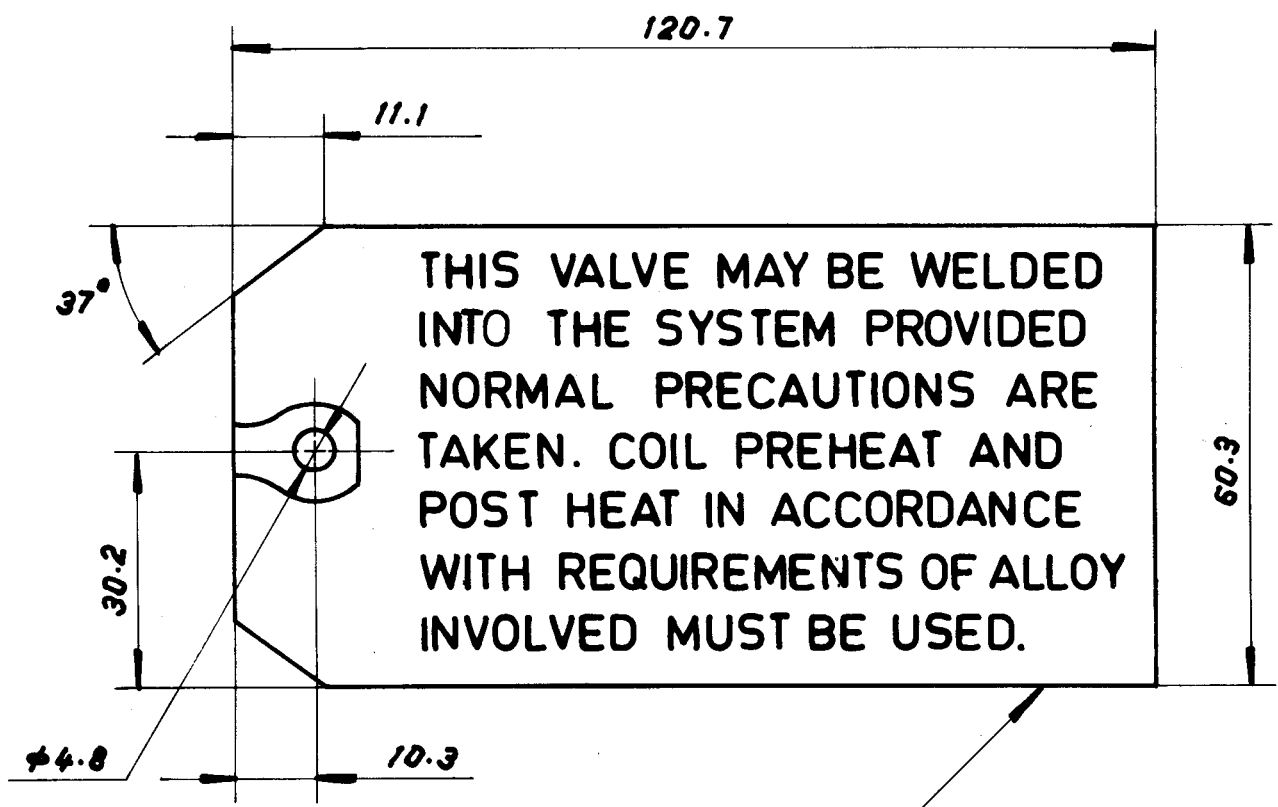

THIS VALVE MAY BE WELDED INTO THE SYSTEM PROVIDED NORMAL PRECAUTIONS ARE TAKEN. COIL PREHEAT AND POST HEAT IN ACCORDANCE WITH REQUIREMENTS OF ALLOY INVOLVED MUST BE USED.

PRINT ON BOTH SIDES

MICROFILMED ON ROLL 005913 FRAME 338

APPL. 1749 WA, 1705 RWD, 1775 WA
DRESSER 1759 WA, 1785 WA,
TYPE NOS 1775 GA, GNB, GWD,

STEEL PLATE t = 1	96 415 021	EC # 5 RED TAG (HEAVY GADE) STEEL.	10	0.06				197	
No. OFF	DESCRIPTION	MATL CODE	FINAL MATL	HEAT TREATMENT	SCRAP SDRT	NET WT (kg)	GROSS WT (kg)	DRG No.	ITEM No.



BHARAT HEAVY ELECTRICALS LIMITED
BOILER PLANT UNIT, TIRUCHIRAPALLI-620014

05-249/A

DEPT	CODE		SCALE 1:1	WEIGHT (kg)	PART No. 4121601 DR. DRG No. 241215/CK 488	S/No. 685		
TITLE TAG					DRAWN	NAME T.R.	SIGN	DATE 28-2-77
					CHECKED	VR		
					APPROVED	JA		

DIMENSIONS TO BE CONTROLLED WITHIN LIMITS AS SHOWN. MACHINING TOLERANCE ± 0.25 mm UNLESS OTHERWISE SHOWN NON-MACHINING TOLERANCE ±

4 DRAWING No. 15 16 REV 17
CARD CODE **4-V-7000-10052**

CAUTION THE INFORMATION ON THIS DOCUMENT IS THE PROPERTY OF BHARAT HEAVY ELECTRICALS LTD IT MUST NOT BE USED DIRECTLY OR INDIRECTLY IN ANY WAY DETRIMENTAL TO THE INTEREST OF THE COMPANY.

REV 01	DATE	ALTERED
CHECKED	02	CHECKED

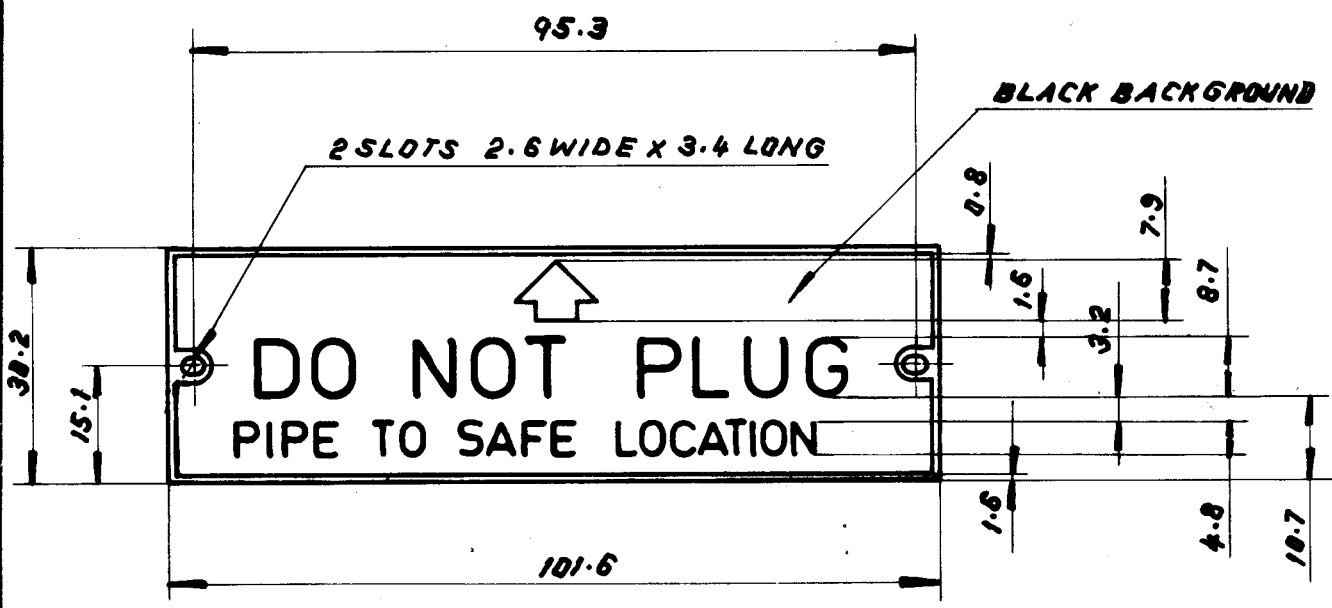

NOTE:-

- BORDERS, CHARACTERS AND ARROW TO BE RAISED AND BUFFED. CHARACTERS ARE EXTRA HEAVY.

MATERIAL :- # 26 B & S GAUGE . (0.016) STEEL
" FENCO ETCH " OR ETCHED BRASS



00523 334

APPL. 1749WA, 1705RWD, 1775WA
DRESSER 1759WA, 1785WA
TYPE No. 1775AWA, GWB, QWD

No. OFF	DESCRIPTION	MATL. CODE	FINAL MATL.	HEAT TREATMENT	SCRAP SORT	NET WT (kg)	GROSS WT (kg)	DRS No.	ITEM No.
	t = 0.405 mm	96415019	# 26 B & S GA. (0.016) STEEL		10	0.01			195



BHARAT HEAVY ELECTRICALS LIMITED
BOILER PLANT UNIT, TIRUCHIRAPALLI-620014

05-249/A

DEPT	CODE	SCALE	WEIGHT (kg.)	PART No. 4/22101	S/No.
		1:1		DR. DRG No. 24/221/CK 478	681

TITLE CAUTION PLATE	DRAWN	NAME	SIGN	DATE
	CHECKED	VR	R	27-6-79
	APPROVED	RA	K	

DIMENSIONS TO BE CONTROLLED WITHIN LIMITS AS SHOWN. MACHINING TOLERANCE ± 0.25 mm UNLESS OTHERWISE SHOWN NON-MACHINING TOLERANCE \pm

CARD CODE	4 DRAWING No.	15	16 REV 17
	4-V-7000-10053		

CAUTION THE INFORMATION ON THIS DOCUMENT IS THE PROPERTY OF BHARAT HEAVY ELECTRICALS LTD IT MUST NOT BE USED DIRECTLY OR INDIRECTLY IN ANY WAY DETRIMENTAL TO THE INTEREST OF THE COMPANY.

REV 01	DATE	ALTERED
REV 02	DATE	ALTERED
CHECKED		CHECKED

APPL.DR
TYPE NoS

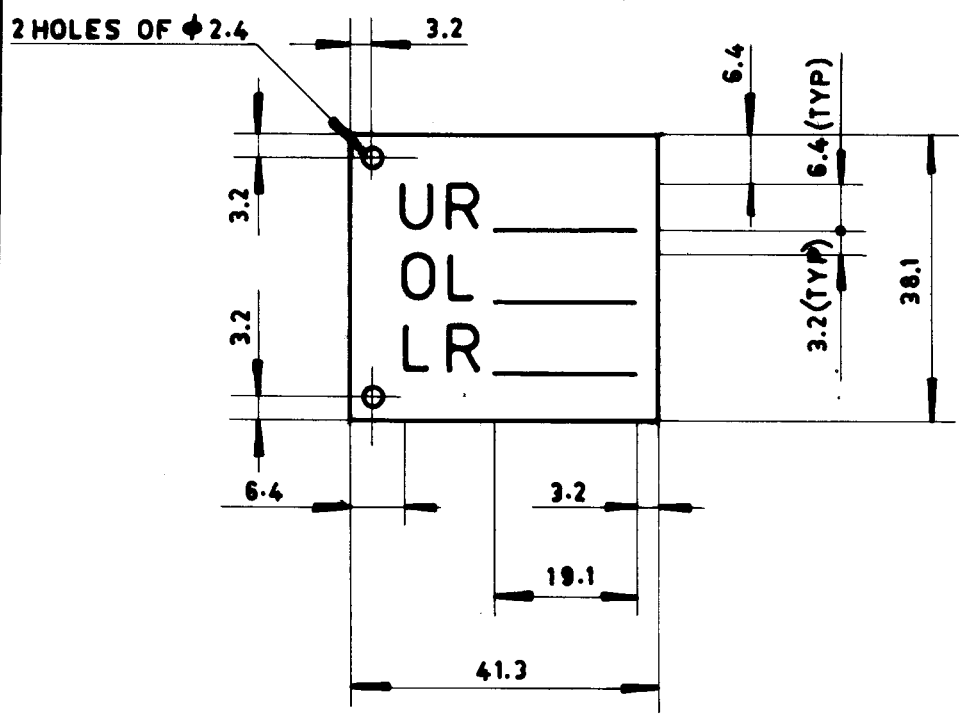

NOTE

1. LETTERS SHOULD BE PRINTED IN RED COLOUR WITH WHITE BACKGROUND

~~REPRODUCED ON~~
~~SPEDB~~

PL. 40 X 45 X 0.5	96 415 050	BMCQ-10	10					200	
No. OFF	DESCRIPTION	MATL CODE	FINAL MATL	HEAT TREATMENT	SCRAP SORT	NET Wt KG	GROSS Wt KG	DRG No.	ITEM No.



BHARAT HEAVY ELECTRICALS LIMITED
BOILER PLANT UNIT, TIRUCHIRAPALLI-620014

DEPT	CODE		SCALE 1:1	WEIGHT (kg.)		
TITLE RING POSITION TAG					DRAWN T.R.	DATE 24/12/79
					CHECKED V.R.	
					APPROVED J.A.	

DIMENSIONS TO BE CONTROLLED WITHIN LIMITS AS SHOWN. MACHINING TOLERANCE ± 0.25 mm. UNLESS OTHERWISE SHOWN NON-MACHINING TOLERANCE \pm	CARD CODE	4 DRAWING NO. 4-V-7000-10097	15	16 REV 17
---	-----------	--	----	-----------

CAUTION THE INFORMATION ON THIS DOCUMENT IS THE PROPERTY OF BHARAT HEAVY ELECTRICALS LTD. IT MUST NOT BE USED DIRECTLY OR INDIRECTLY IN ANY WAY DETRIMENTAL TO THE INTEREST OF THE COMPANY

REV 02	DATE	ALTERED
		CHECKED

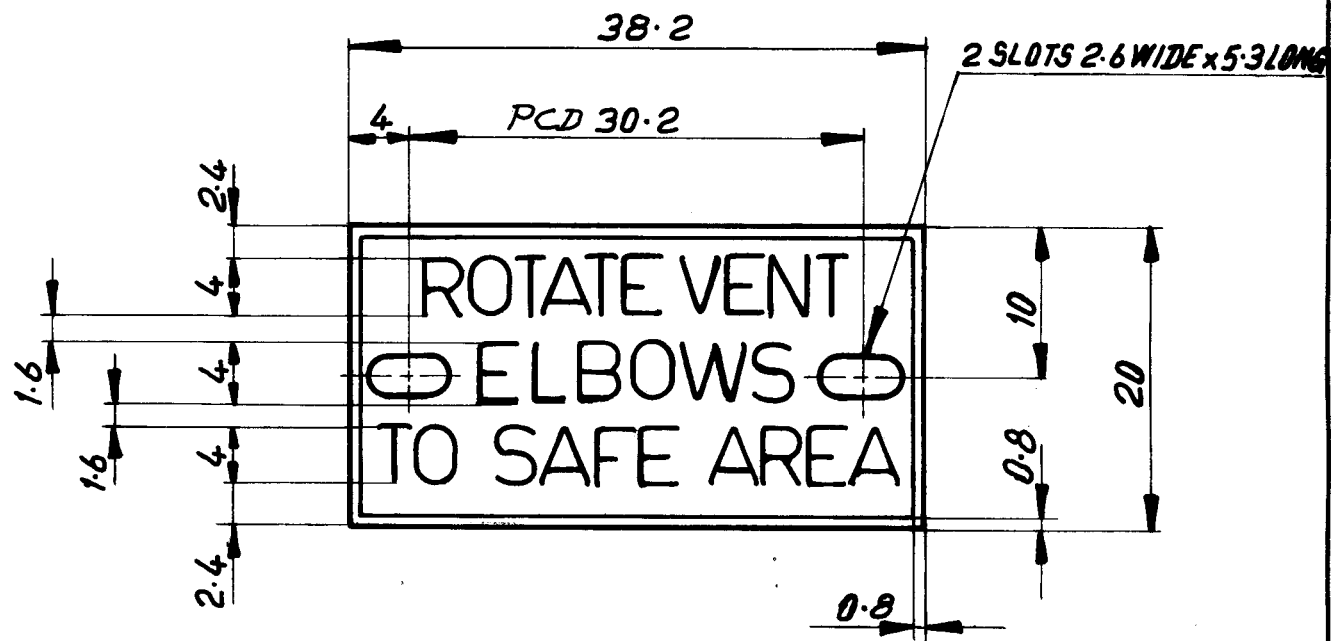

NOTES:

- MATERIAL: ACTUAL SIZE
18-8 STAINLESS STEEL, t: 0.4064 mm (0.016") - # 26 B & S GAUGE.
- ALL LETTERS ARE TO BE BLOCK LETTERS
- BLACK BACKGROUND WITH RAISED AND BUFFED LINE AND LETTERS
CODE:-22073605

MICROFILMED ON
ROLL 00523 FRAME 223

	Bharat Heavy Electricals Ltd., BOILER PLANT UNIT TIRUCHIRAPALLI-620 014		DRN	NAME N.R	SIGN N. Ramesh	DATE 24-2-81
			CHD	K.B	K. N. K.	
			APPD	J.A	JA	
DEPT.	GRADE OF UNTOL. DIM		SCALE	WEIGHT (kg)	DRG NO:-112572 DRESSER PART NO:-1257201 (REV:- C7398 (SL NO:-568))	
CODE	C/M/F		2:1			
TITLE			CARD CODE	DRAWING NO.		ITEM NO
NAME PLATE [VENT]			U 01	4-V-750-10158		454

FOR TOLERANCES OF UNTOLERANCED DIMENSIONS DURING MANUFACTURE REFER RELEVANT QCP/QP

CAUTION: The information on this document is the property of BHARAT HEAVY ELECTRICALS LTD. It must not be used directly or indirectly in any way detrimental to the interest of the company.

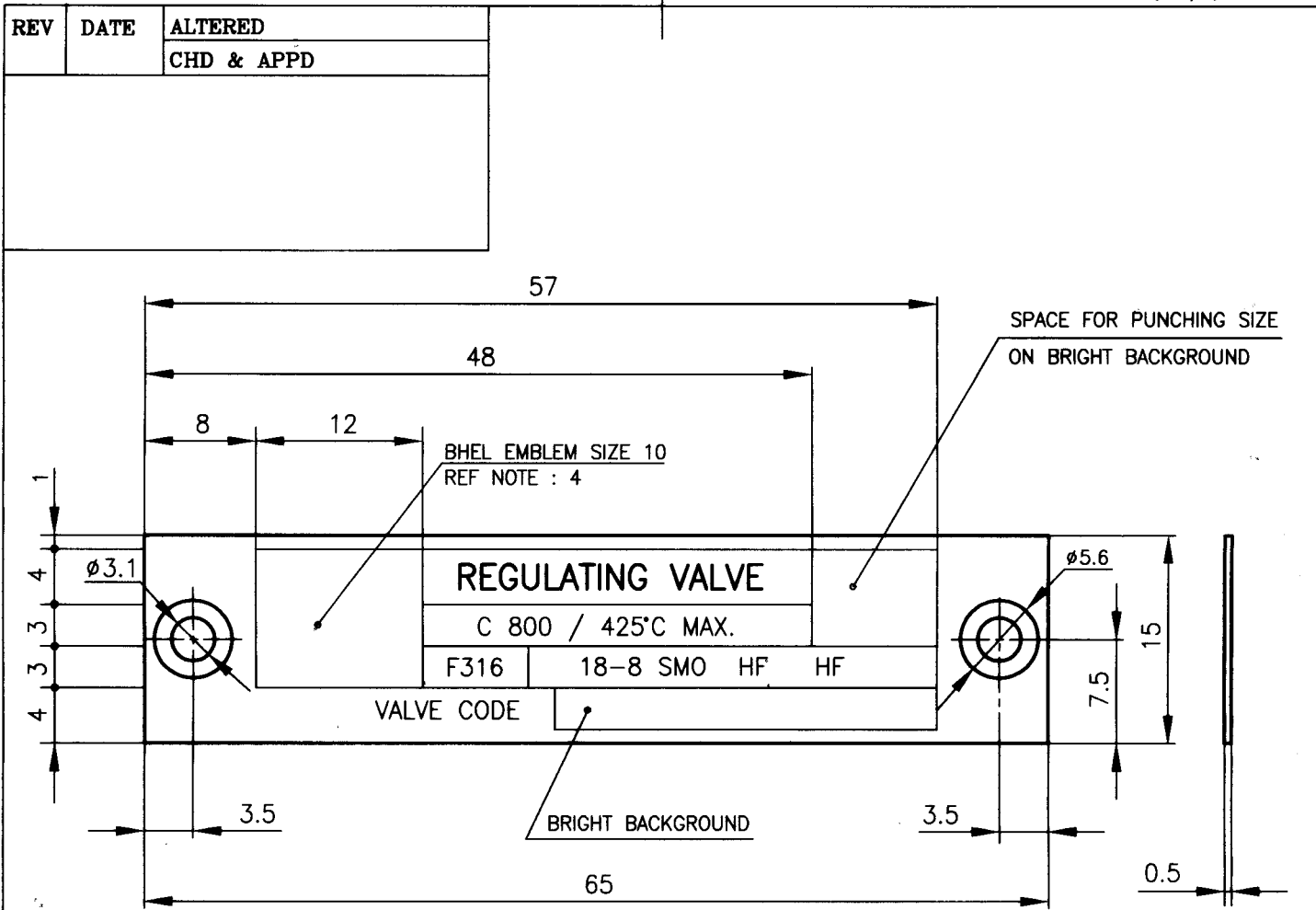

NOTES:

1. MATERIAL : 18-8 Cr. Ni. STAINLESS STEEL.
2. THE NAME PLATE SHALL HAVE RAISED BRIGHT POLISHED LETTERS, MONOGRAM, ETC. ON ETCHED BLACK ENAMELLED BACKGROUND.
3. THE ENAMEL SHALL BE CRACK RESISTING SO THAT WHEN BENT THE ENAMEL DOES NOT CRACK.
4. MONOGRAM SHALL BE BASED ON CORPORATE STANDARD No. AA 040 11 20 (LATEST REVISION).
5. FINAL THICKNESS OF THE NAME PLATE AFTER ETCHING, ENAMELLING & POLISHING SHALL NOT BE LESS THAN 0.5mm. SUPPLIERS SHALL TAKE SUITABLE RAW MATERIAL THICKNESS TO MEET THE SPECIFIED FINAL THICKNESS.

NO OFF	DESCRIPTION	MATL CODE	MATL SPECN	HEAT TREATMENT	SCRAP SORT	NET WT (kg)	GROSS WT (kg)	DRAWING No	ITEM No
<p>BHARAT HEAVY ELECTRICALS LTD., UNIT: HIGH PRESSURE BOILER PLANT. TIRUCHIRAPALLI 620014.</p>					DRN	R. MOHAN	SIGN	DATE	NO. OF YEAR
					CHD	K.S. RAMAN	<i>K.S. Raman</i>	07.07.97	
					APPD	N. NAGARAJAN.	<i>N. Nagarajan</i>	10.7.97	
DEPT VL	/		SCALE	WEIGHT (KG).	REFERENCE INFORMATION				NO. OF ITEMS
CODE			N T S	0.003	COMP. CODE: 9648689000 H2855100 CAD: F426039				
TITLE					CARD CODE	DRAWING NO.			REV
NAME PLATE					U 01	4-V-H285-26039			

CAUTION: The information on this document is the property of BHARAT HEAVY ELECTRICALS LTD. It must not be used directly or indirectly in any way detrimental to the interest of the company.

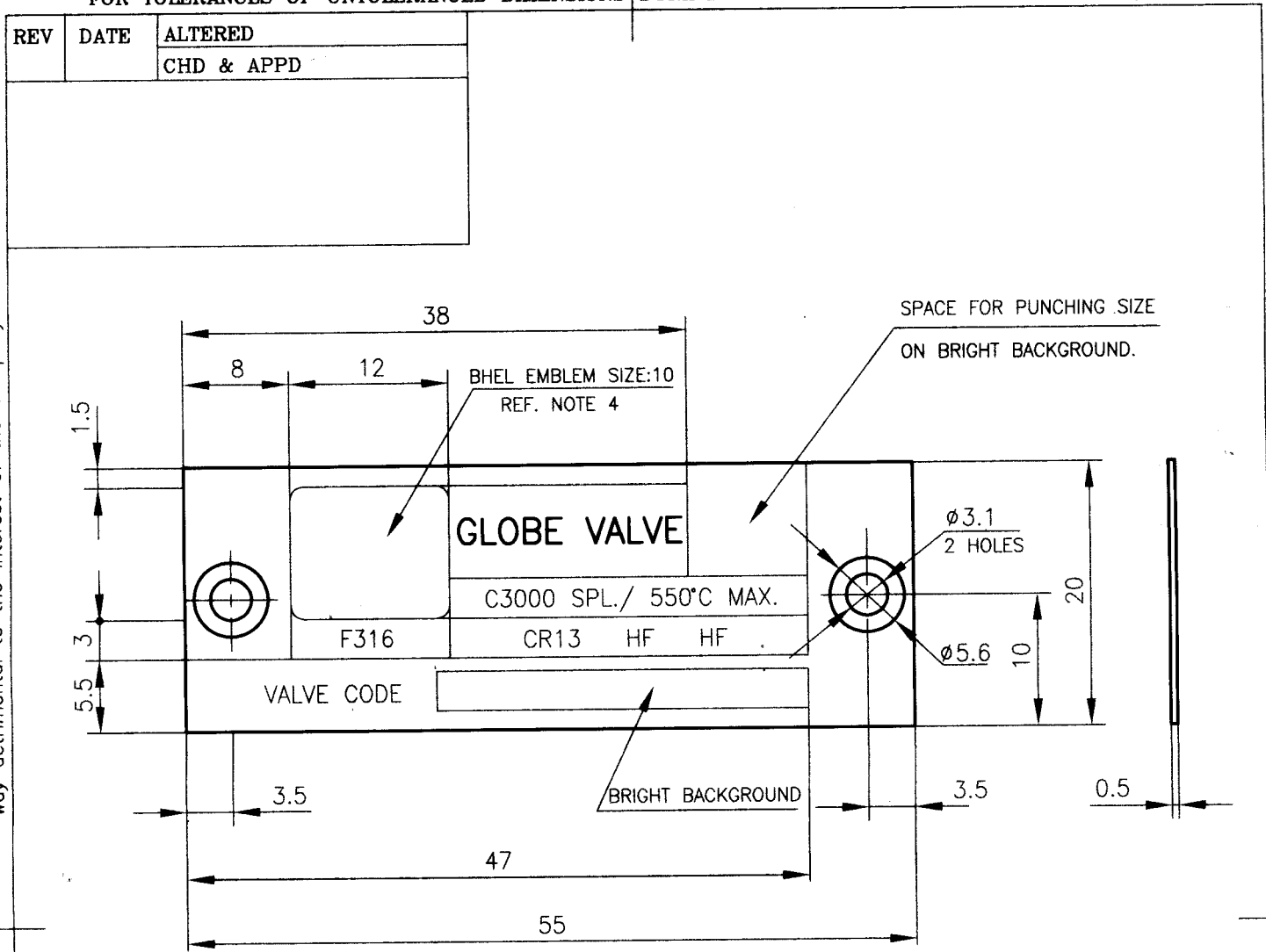

NOTES :-

1. MATERIAL : 18-8 Cr. Ni. STAINLESS STEEL.
2. THE NAME PLATE SHALL HAVE RAISED BRIGHT POLISHED LETTERS, MONOGRAM, ETC. ON ETCHED BLACK ENAMELLED BACKGROUND.
3. THE ENAMEL SHALL BE CRACK RESISTING SO THAT WHEN BENT THE ENAMEL DOES NOT CRACK.
4. MONOGRAM SHALL BE BASED ON CORPORATE STANDARED No. AA 040 11 20 (LATEST REV.)
5. FINAL THICKNESS OF THE NAME PLATE AFTER ETCHING, ENAMELLING & POLISHING SHALL NOT BE LESS THAN 0.5mm. SUPPLIERS SHALL TAKE SUITABLE RAW MATERIALS THICKNESS TO MEET THE SPECIFIED FINAL THICKNESS.

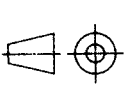
NO OFF	DESCRIPTION	MATL CODE	MATL SPECN	HEAT TREATMENT	SCRAP SORT	NET WT (kg)	GROSS WT (kg)	DRAWING No	ITEM No
	 BHARAT HEAVY ELECTRICALS LTD., UNIT: HIGH PRESSURE BOILER PLANT. TIRUCHIRAPALLI 620014. 365-122								
		DRN	M.SRINIVASAN	SIGN	<i>[Signature]</i>	DATE	23.01.01	NO. OF VAR	
		CHD	P. BOOMINATHAN	SIGN	<i>[Signature]</i>	DATE	23.01.01		
	APPD	K.S.RAMAN	SIGN	<i>[Signature]</i>	DATE	23.01.01			
DEPT VL		SCALE	WEIGHT (KG).	REFERENCE INFORMATION				NO. OF ITEMS	
CODE		N T S	0.003	COMP. CODE: 96 465 065 0000					
TITLE					CARD CODE	DRAWING NO.			REV
NAME PLATE					U 01	4-V-H413-26335			

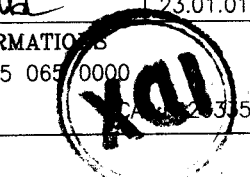

FOR TOLERANCES OF UNTOLERANCED DIMENSIONS DURING MANUFACTURE REFER RELEVANT QCP/QP

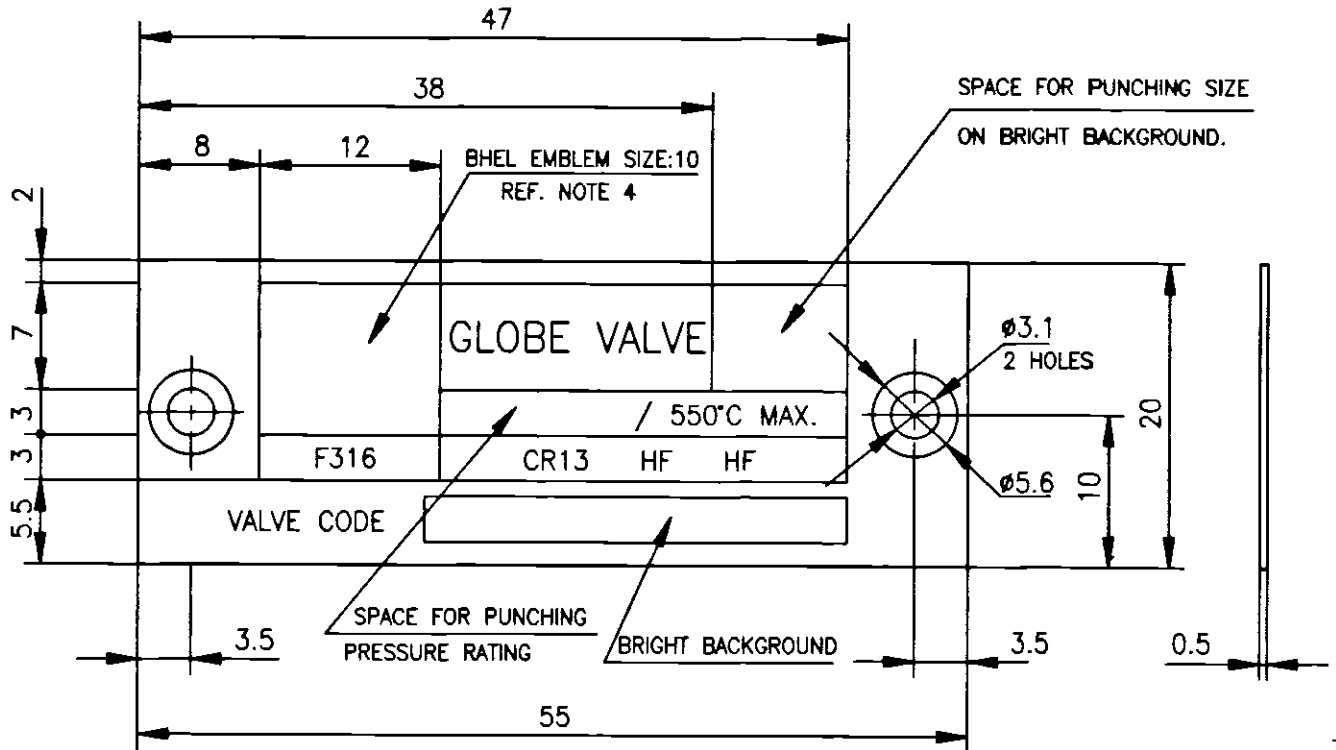

ALL DIMENSIONS ARE IN MILLIMETRES.

REV	DATE	ALTERED
		CHD & APPD



NOTES :-

1. MATERIAL : 18-8 Cr. Ni. STAINLESS STEEL.
2. THE NAME PLATE SHALL HAVE RAISED BRIGHT POLISHED LETTERS, MONOGRAM, ETC. ON ETCHED BLACK ENAMELLED BACKGROUND.
3. THE ENAMEL SHALL BE CRACK RESISTING SO THAT WHEN BENT THE ENAMEL DOES NOT CRACK.
4. MONOGRAM SHALL BE BASED ON CORPORATE STANDARED No. AA 040 11 20 (LATEST REV.)
5. FINAL THICKNESS OF THE NAME PLATE AFTER ETCHING, ENAMELLING & POLISHING SHALL NOT BE LESS THAN 0.5mm. SUPPLIERS SHALL TAKE SUITABLE RAW MATERIAL THICKNESS TO MEET THE SPECIFIED FINAL THICKNESS.

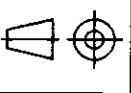
NO OFF	DESCRIPTION	MATL CODE	MATL SPECN	HEAT TREATMENT	SCRAP SORT	NET WT (kg)	GROSS WT (kg)	DRAWING No	ITEM No
 BHARAT HEAVY ELECTRICALS LTD., UNIT: HIGH PRESSURE BOILER PLANT. TIRUCHIRAPALLI 620014.					DRN	NAME	SIGN	DATE	NO. OF VAR
					CHD	M.SRINIVASAN	<i>[Signature]</i>	27.07.02	
					APPD	T.R.RAMAMURTHY	<i>[Signature]</i>	27.07.02	
						P.BOMMINATHAN	<i>[Signature]</i>	27.07.02	
DEPT VL			SCALE	WEIGHT (KG).	REFERENCE INFORMATIONS				NO. OF ITEMS
CODE			N T S	0.003	COMP. CODE: 96 465 129 0000 CAD:F426417				
TITLE					CARD CODE	DRAWING NO.			REV
NAME PLATE					U 01	4-V-H631-26417			

CAUTION: The information on this document is the property of BHARAT HEAVY ELECTRICALS LTD. It must not be used directly or indirectly in any way detrimental to the interest of the company.

FOR TOLERANCES OF UNTOLERANCED DIMENSIONS DURING MANUFACTURE REFER RELEVANT QCP/QP

REV	DATE	ALTERED
		CHD & APPD

CAUTION: The information on this document is the property of BHARAT HEAVY ELECTRICALS LTD. It must not be used directly or indirectly in any way detrimental to the interest of the company.

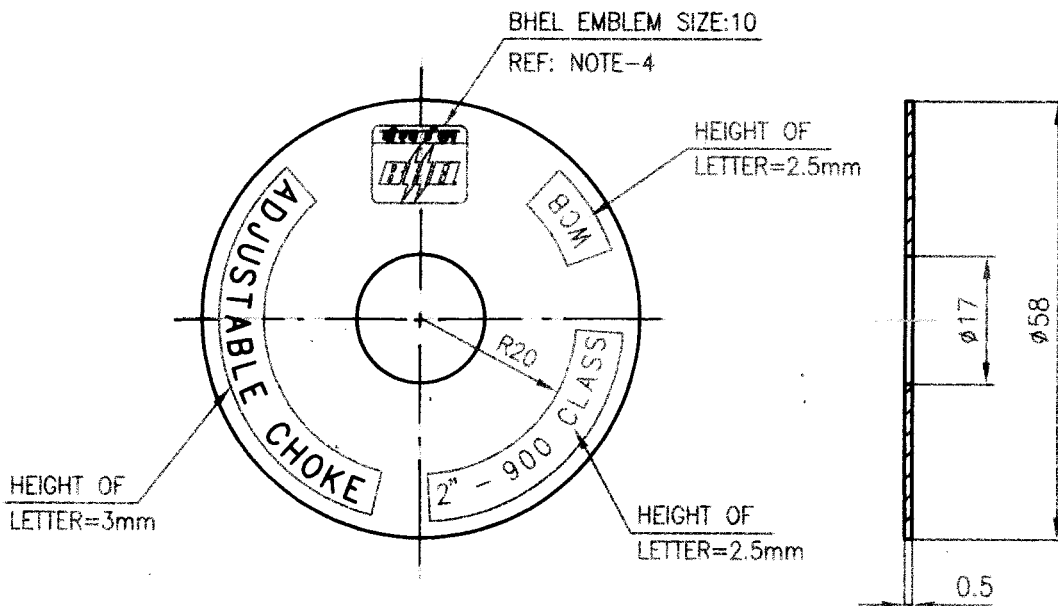

NOTES:

1. MATERIAL: 18-8 Cr. Ni STAINLESS STEEL
2. THE NAME PLATE SHALL HAVE RAISED BRIGHT POLISHED LETTERS, EMBLEM ETC. ON ETCHED BLACK ENAMELLED BACKGROUND
3. THE ENAMEL SHALL BE CRACK RESISTING SO THAT WHEN BENT THE ENAMEL DOES NOT CRACK.
4. MONOGRAM SHALL BE BASED ON CORPORATE STANDARD No. AA 040 11 20 (LATEST REV.)
5. FINAL THICKNESS OF THE NAME PLATE AFTER ETCHING, ENAMELLING & POLISHING SHALL NOT BE LESS THAN 0.5mm.

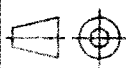
NO OFF	DESCRIPTION	MATL CODE	MATL SPECN	HEAT TREATMENT	SCRAP SORT	NET WT (kg)	GROSS WT (kg)	DRAWING No	ITEM No
	 BHARAT HEAVY ELECTRICALS LTD. UNIT: HIGH PRESSURE BOILER PLANT. TIRUCHIRAPALLI 620014. 365-122								
		DRN	M.SRINIVASAN	SIGN	M.S.	DATE	05.06.97	NO. OF VAR	
		CHD	K.S. RAMAN	SIGN	K.S.	DATE	06/06/97		
		APPD	N.NAGARAJAN	SIGN	N.N.	DATE	06/06/97		
DEPT VL	CODE 320		SCALE	NTS	WEIGHT (KG).	0.01	REFERENCE INFORMATION	COMP. CODE 2615 20000	NO. OF ITEMS
TITLE					CARD CODE	DRAWING NO.			REV
NAME PLATE					U 01	4-V-M766-26042			

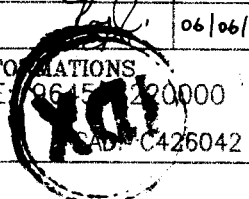



PLANT STANDARD

HPBP TIRUCHIRAPPALLI

BPS 017202

Rev. No. 03

PAGE 1 OF 4

RATING PLATE-LONG RETRACTABLE SOOT BLOWER

0.0 SCOPE

This standard covers the requirements of Rating Plate for long retractable soot blower.

1.0 SPECIFICATION AND REFERENCE STANDARDS

Dimensions and preferred sizes Fig.1 of this standard

Tolerance Medium to IS: 2102

Material CuSn37 HA, 1.6 mm thick acc. to IS 410

BHEL monogram Acc. to corporate standard AA 040 1120

Lettering style Acc. to corporate standard AA 042 1403

Finish See clauses 2.0 to 2.5 of this standard

Technical delivery conditions Acc. to corporate standard AA 085 1411

2.0 FINISH

2.1 All rating plates shall be manufactured by etching and shall meet the following technical and other requirements.

2.2 TOP PORTION: All letters of the name of the company and monogram with border shall be raised and bright nickel plated. The background shall be etched and finished black (stoving enamel).

Revisions **Brought Upto Date**

Approved

STANDARDS SECTION
CONTRACT ENGINEERING AND CO-ORDINATION
HPBP, TIRUCHIRAPPALLI

Rev. No. 03

Amd. No.

Reaffirmed

Prepared

Issued

Dt of 1st Issue

Dt. 18-1-97

Dt.

Year

STANDARDS

STANDARDS

JAN 1984



PLANT STANDARD

HPBP TIRUCHIRAPPALLI

BPS 017202

Rev. No. 03

PAGE 2 OF 4

2.3 MIDDLE PORTION:

2.3.1 The following details of this portion shall be raised and bright nickel plated.

- All letters of the name of the equipment.
- All 'pads' on which the rating particulars shall appear.

2.3.2 The following details of this portion shall be etched and finished black (stoving enamel).

- All letters, numerals etc. of the rating details appearing on the pads.
- All the dividing lines separating the pads from each other.
- Remaining area in the background.

2.4 BOTTOM PORTION: All letters shall be raised and right nickel plated.
Remaining area in the background shall be etched and finished black (stoving enamel).

2.5 Border around the rating plate and the two dividing lines shall be raised and bright nickel plated.

3.0 DESIGNATION

A rating plate of size 180 mm length and 108 mm width to this standard shall be designated as :

3.1 On drawings

- a) Description column : RATG PL-LRSB 180x108
- b) Drawing number column : BPS 017202
- c) Material spec. column : Brass
- d) Material code column : 22 073 647¹



PLANT STANDARD

HPBP TIRUCHIRAPPALLI

BPS 017202

Rev. No. 03

PAGE 3 OF 4

3.2 Ordering description

For placing indents, issuing enquiries and on purchase orders, ordering description given below shall be followed.

Rating plate - long retractable soot blower to BPS 017202

4.0 ADDITIONAL INFORMATION

4.1 Copies of the following standards shall be enclosed along with purchase order.

- a) BPS 017 202
- b) AA 040 1120
- c) AA 042 1403
- d) AA 085 1411

4.2 Material code shall be painted at the back of each piece.

4.3 The figure shown is for illustration only and supplier has to submit drawings to actual size for approval before effecting bulk supplies.



PLANT STANDARD

HPBP TIRUCHIRAPPALLI

BPS 017522

Rev. No. 02

PAGE 1 OF 3

NAME PLATE FOR VALVES

0.0 SCOPE

This standard covers the requirements of Name Plate for valves.

1.0 SPECIFICATION AND REFERENCE STANDARDS

Dimensions and preferred sizes	Fig.1 and table 1 of this standard
Tolerance	Medium to IS: 2102
Material	Aluminium sheet of thickness 0.5 mm
BHEL Monogram	According to corporate standard AA 040 1120
Lettering style	Acc. to corporate standard AA 042 1403
Finish	See clause 2.1 of this standard
Technical delivery conditions	Acc. to clause 3.0 to 3.3.2 of this standard

2.0 FINISH

2.1 The Name plate shall be hard anodized according to IS: 6057 incorporating the matter as shown in the figure 1. The letters, space for data, BHEL monogram and border shall be finished bright white with black background.

3.0 TECHNICAL REQUIREMENTS

3.1 GENERAL

3.1.1 The surface shall be free of cracks, blisters and damages. Sharp edges shall be rounded off.

3.1.2 Samples of the name plate shall be obtained and tested in the laboratory for durability of the material, anodizing and weather proofness before bulk supply is effected.

Revisions

Brought upto date

Approved

STANDARDS SECTION -
CONTRACT ENGINEERING AND CO-ORDINATION
HPBP, TIRUCHIRAPPALLI

Rev. No. 02	Amd. No.	Reaffirmed	Prepared	Issued	Dt of 1st Issue
Dt. 18-1-'97	Dt. -	Year	STANDARDS	STANDARDS	AUG 1984

COPYRIGHT AND CONFIDENTIAL
The information on this document is the property of BIHARAT HEAVY ELECTRICALS LIMITED. It must not be used directly or indirectly in any way detrimental to the interest of the company.



PLANT STANDARD

HPSP TIRUCHIRAPPALLI

BPS 017522

Rev.No. 02

PAGE 2 OF 3

3.2 MARKING. Back side of each name plate shall be marked with material code given by BHEL and with manufacturer's identification.

3.3 PACKING.

3.3.1 Before packing, each name plate shall be applied with transparent synthetic adhesive film.

3.3.2 Each name plate shall be suitably packed in polythene cover (500 microns thickness minimum) in order to avoid any damage to the surface during transit/storage etc.

4.0 DESIGNATION

A Name plate for valve of size 15x55 to this standard shall be designated as :

4.1 On drawings

a) Description column	: NPL VALVES 15x55
b) Drawing number column	: BPS 017522 1555
c) Material spec. column	: Aluminium
d) Material code column	: <u>22 074 165</u>

4.2 Ordering description

For placing indents, issuing enquiries and on purchase orders, ordering description given below shall be followed.

Name plate for valves of size 15x55 to BPS 017522

5.0 ADDITIONAL INFORMATION

5.1 Copies of the following standards shall be enclosed along with purchase order.

a) BPS 017 522
b) AA 040 1120
c) AA 042 1403

5.2 The figure shown is for illustration only and supplier has to submit drawings to actual size for approval before effecting bulk supplies.

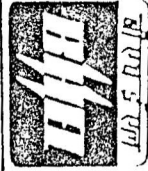

PLANT STANDARD

HPBP TIRUCHIRAPPALLI

BPS 017522

Rev. No. 02

PAGE 3 OF 3

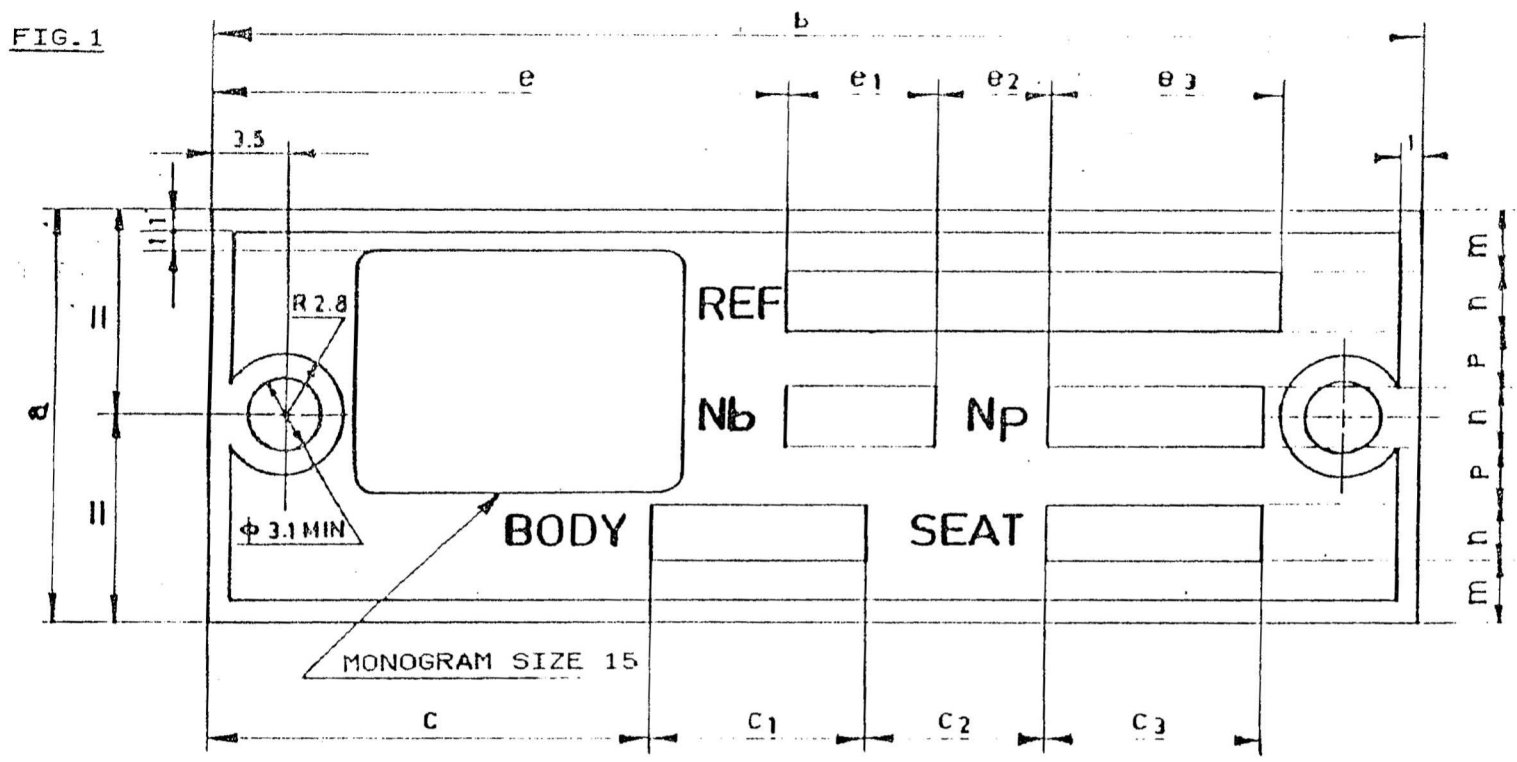

TABLE:1

(ALL DIMENSIONS IN MILLIMETRES)

SIZE a x b	c	c ₁	c ₂	c ₃	e	e ₁	e ₂	e ₃	m	n	p	ENAMELLED	PUNCHED	≈WEIGHT/ 1000 IN KG
												2	1.5	
20 X 80	23	20	10	20	33	12	8	20.7	3	4	1	2	2	2.16
15 X 55	20	10	8	10	26	7	5	10.7	2	3	1	2	1.5	1.12



PLANT STANDARD

HPBP TIRUCHIRAPPALLI

BPS 017537

Rev.No. 02

PAGE 1 OF 3

BLANK NAME PLATE FOR VALVES

0.0 SCOPE

This standard covers the requirements of Blank name plate for valves.

1.0 SPECIFICATION AND REFERENCE STANDARDS

Dimensions and preferred sizes	Fig.1 and table 1 of this standard
Tolerance	Medium to IS: 2102
Material	Aluminium sheet of thickness 1 mm
Finish	See clause 2.1 of this standard
Technical delivery conditions	Acc. to clause 3.0 to 3.3.2 of this standard

2.0 FINISH

2.1 Name plates shall be hard anodized according to IS: 6057 incorporating border as blue colour with white background.

3.0 TECHNICAL REQUIREMENTS

3.1 GENERAL

3.1.1 The surface shall be free of cracks, blisters and damages. Sharp edges shall be rounded off.

3.1.2 Samples of the name plates shall be obtained and tested in the laboratory for durability of the material, anodizing and weather proofness before bulk supply is effected.

3.2 MARKING. Back side of each name plate shall be marked with material code given by BHEL and with manufacturer's identification.

Revisions

Brought upto date

Approved

STANDARDS SECTION
CONTRACT ENGINEERING AND CO-ORDINATION
HPBP, TIRUCHIRAPPALLI

Rev. No. 02

Amd. No.

Reaffirmed

Prepared

Issued

Dt of 1st Issue

Dt. 18-1-97

Dt.

Year

STANDARDS

STANDARDS

AUG 1984

COPYRIGHT AND CONFIDENTIAL

The information on this document is the property of BIHARAT HEAVY ELECTRICALS LIMITED. It must not be used directly or indirectly in any way detrimental to the interest of the company.



PLANT STANDARD

HPBP TIRUCHIRAPPALLI

BPS 017537

Rev.No. 02

PAGE 2 OF 3

3.3 PACKING.

3.3.1 Before packing, each name plate shall be applied with transparent synthetic adhesive film.

3.3.2 Each name plate shall be suitably packed in polythene cover (500 microns thickness minimum) in order to avoid any damage to the surface during transit/storage etc.

4.0 DESIGNATION

A Blank name plate for valve of size 20x75 to this standard shall be designated as :

4.1 On drawings

- a) Description column : NPL BLANK 20x75
- b) Drawing number column : BPS 017537 2075
- c) Material spec. column : Aluminium
- d) Material code column : 22 074 566

4.2 Ordering description

For placing indents, issuing enquiries and on purchase orders, ordering description given below shall be followed.

Blank name plate for valves, size 20x75 to BPS 017537

5.0 ADDITIONAL INFORMATION

5.1 Copies of the following standards shall be enclosed along with purchase order.

- a) BPS 017 537

5.2 The figure shown is for illustration only and supplier has to submit drawings to actual size for approval before effecting bulk supplies.



PLANT STANDARD

HPBP TIRUCHIRAPPALLI

BPS 017537

Rev. No. 02

PAGE 3 OF 3

BLANK NAME PLATE FOR VALVES

ALL DIMENSIONS IN MILLIMETRES

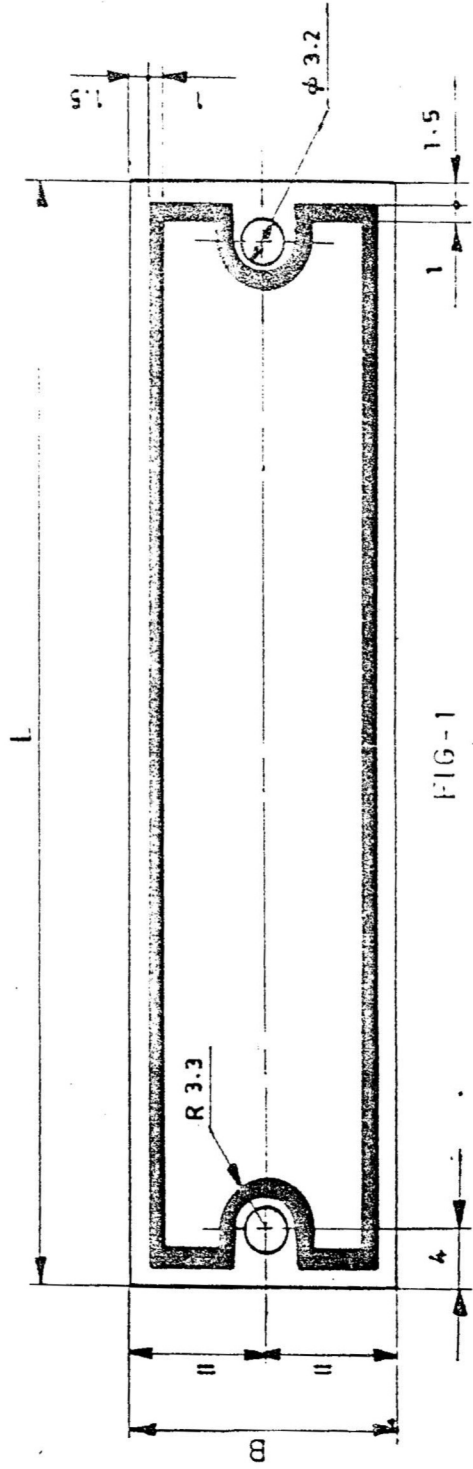

TABLE - 1

VAR No.	BREATH B	LENGTH L
01	20	75
02	15	55



PLANT STANDARD

HPBP TIRUCHIRAPPALLI

BPS 317544

Rev. No. 02

PAGE 01 OF 03

Material Code: 2207472

CAUTION PLATE (FOR DECLUTCHING THE BLOWER)

0.0 SCOPE

This standard covers the requirements of Caution Plate for declutching the blower.

1.0 SPECIFICATION AND REFERENCE STANDARDS

Dimensions and preferred sizes Fig.1 of this standard

Material CuSn37 HA, 0.5mm thick acc. to IS 410

Lettering style Acc. to corporate standard AA 042 1403

Finish See clause 2.1 to 2.2 of this standard

Technical delivery conditions Acc. to corporate standard AA 085 1411

2.0 FINISH

2.1 All caution plates shall be manufactured by etching and shall meet the technical delivery conditions.

2.2 All letters of the caution plate and border shall be raised and bright nickel plated. The back ground shall be etched and finished black (stoving enamel).

COPYRIGHT AND CONFIDENTIAL

The information on this document is the property of BHARAT HEAVY ELECTRICALS LIMITED. It must not be used directly or indirectly in any way detrimental to the interest of the company.

Revisions			Approved		
BROUGHT UPTO DATE			STANDARDS SECTION CONTRACT ENGINEERING AND CO-ORDINATION HPBP, TIRUCHIRAPPALLI		
Rev. No. 02	Amd. No.	Reaffirmed	Prepared	Issued	Dt of 1st Issue
Dt. 04.10.97	Dt.	Year	STANDARDS	STANDARDS	AUG 1984



PLANT STANDARD

HPBP TIRUCHIRAPPALLI

BPS 017544

Rev. No. 02

PAGE 02 OF 03

3.0 DESIGNATION (typical case)

A caution plate of size 20 mm width and 80 mm length to this standard shall be designated as:

3.1 On drawings

- a) Description column : CAUTION PL DCLUCH
- b) Drawing number column : BPS 017544
- c) Material spec. column : Brass
- d) Material code column : 22 074 721

3.2 Ordering description

For placing indents, issuing enquiries and on purchase orders, ordering description given below shall be followed.

Caution plate of size 20 x 80 to BPS: 017544

4.0 ADDITIONAL INFORMATION

4.1 Copies of the following standards shall be enclosed along with purchase order.

- a) BPS 017 544
- b) AA 042 1403
- c) AA 085 1411

4.2 Material code shall be painted at the back of each piece.

4.3 Supplier has to submit drawings to actual size for approval before effecting bulk supplies.



PLANT STANDARD

HPBP TIRUCHIRAPPALLI

BPS 017544

Rev. No. 02

PAGE 03 OF 03

CAUTION PLATE (FOR DECLUTCHING THE BLOWER)

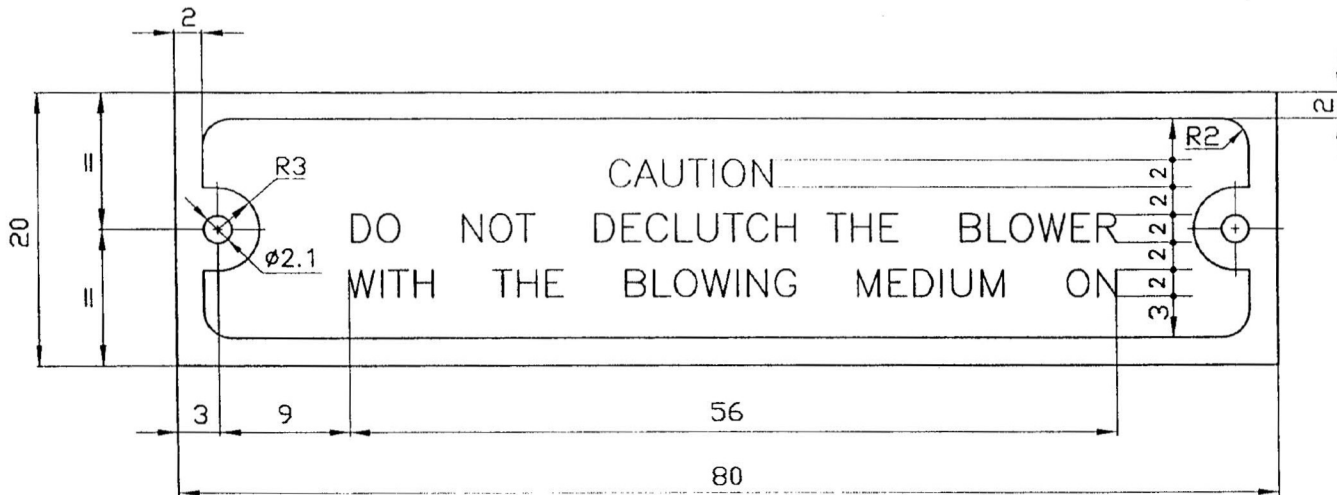

(ALL DIMENSIONS ARE IN MILLIMETRES)

FIG:1



PLANT STANDARD

HPBP TIRUCHIRAPPALLI

BPS 017205

Rev. No. 02

PAGE 1 OF 4

RATING PLATE-ROTARY SOOT BLOWER

0.0 SCOPE

This standard covers the requirements of Rating Plate for rotary soot blower.

1.0 SPECIFICATION AND REFERENCE STANDARDS

Dimensions and preferred sizes	Fig.1 of this standard
Tolerance	Medium to IS: 2102
Material	CuSn37 HA, 1.6 mm thick acc. to IS 410
BHEL monogram	Acc. to corporate standard AA 040 1120
Lettering style	Acc. to corporate standard AA 042 1403
Finish	See clauses 2.0 to 2.5 of this standard
Technical delivery conditions	Acc. to corporate standard AA 085 1411

2.0 FINISH

- 2.1 All rating plates shall be manufactured by etching and shall meet the following technical and other requirements.
- 2.2 TOP PORTION: All letters of the name of the company and monogram with border shall be raised and bright nickel plated. The background shall be etched and finished black (stoving enamel).

Revisions

Brought upto date

Approved

STANDARDS SECTION
CONTRACT ENGINEERING AND CO-ORDINATION
HPBP, TIRUCHIRAPPALLI

Rev. No. 02

Amd. No.

Reaffirmed

Prepared

Issued

Dt of 1st Issue

Dt. 18.01.97

Dt.

Year

STANDARDS

STANDARDS

DEC 1982



PLANT STANDARD

HPBP TIRUCHIRAPPALLI

BPS 017205

Rev. No. 02

PAGE 2 OF 4

2.3 MIDDLE PORTION:

2.3.1 The following details of this portion shall be raised and bright nickel plated.

- All letters of the name of the equipment.
- All 'pads' on which the rating particulars shall appear.

2.3.2 The following details of this portion shall be etched and finished black (stoving enamel).

- All letters, numerals etc. of the rating details appearing on the pads.
- All the dividing lines separating the pads from each other.
- Remaining area in the background.

2.4 BOTTOM PORTION: All letters shall be raised and bright nickel plated. Remaining area in the background shall be etched and finished black (stoving enamel).

2.5 Border around the rating plate and the two dividing lines shall be raised and bright nickel plated.

3.0 DESIGNATION

A rating plate of size 125 mm length and 75 mm width to this standard shall be designated as :

3.1 On drawings

- a) Description column : RATG PL-RB 125x75
- b) Drawing number column : BPS 017205
- c) Material spec. column : Brass
- d) Material code column : 22.073 635

3.2 Ordering description

For placing indents, issuing enquiries and on purchase orders, ordering description given below shall be followed.

Rating plate - rotary soot blower to BPS 017205



PLANT STANDARD

HPBP TIRUCHIRAPPALLI

BPS 017205

Rev. No. 02

PAGE 3 OF 4

4.0 ADDITIONAL INFORMATION

4.1 Copies of the following standards shall be enclosed along with purchase order.

a) BPS 017 205

b) AA 040 1120

c) AA 042 1403

d) AA 085 1411

4.2 Material code shall be painted at the back of each piece.

4.3 The figure shown is for illustration only and supplier has to submit drawings to actual size for approval before effecting bulk supplies.



PLANT STANDARD

HPBP TIRUCHIRAPPALLI

BPS 017510

Rev. No. 02

PAGE 1 OF 3

DIRECTION PLATE

0.0 SCOPE

This standard covers the requirements of direction plate.

1.0 SPECIFICATION AND REFERENCE STANDARDS

Dimensions and preferred sizes	Fig.1 & table 1 of this standard
Tolerance	Medium to IS: 2102
Material	CuSn37 HA, 1 mm thick, acc. to IS 410
Finish	See clauses 2.0 to 2.2 of this standard
Technical delivery conditions	Acc. to corporate standard AA 085 1411

2.0 FINISH

- 2.1 All direction plates shall be manufactured by etching and shall meet the following technical and other requirements
- 2.2 Arrow and border shall be raised and finished bright by plating. The background shall be etched and finished black (stoving enamel).

3.0 DESIGNATION

A direction plate of breadth 20mm and length 75mm, to this standard shall be designated as:

Revisions

Brought upto date

Approved

STANDARDS SECTION
CONTRACT ENGINEERING AND CO-ORDINATION
HPBP, TIRUCHIRAPPALLI

Rev. No. 02

Amd. No.

Reaffirmed

Prepared

Issued

Dt of 1st Issue

Dt. 18.01.97

Dt.

Year

STANDARDS

STANDARDS

AUG. 1984



PLANT STANDARD

HPBP TIRUCHIRAPPALLI

BPS 017510

Rev. No. 02

PAGE 2 OF 3

3.1 On drawings

- a) Description column : NPL DTN PLATE 20x75
- b) Drawing number column : BPS 017510 2075
- c) Material spec. column : Brass
- d) Material code column : 22 074 128

3.2 Ordering description

For placing indents, issuing enquiries and on purchase orders, ordering description given below shall be followed.

Direction plate, size 20x75 to BPS 017510

4.0 ADDITIONAL INFORMATION

4.1 Copies of the following standards shall be enclosed along with purchase order.

- a) BPS 017 510
- b) AA 085 1411

4.2 Material code shall be painted at the back of each piece.

4.3 The figure shown is for illustration only and supplier has to submit drawings to actual size for approval before effecting bulk supplies.

