

**BHARAT HEAVY ELECTRICALS LIMITED
TRANSMISSION BUSINESS GROUP
SUBCONTRACTS MANAGEMENT
BHEL SADAN, PLOT NO. 25, SECTOR 16A, NOIDA,
DISTT. – GAUTAM BUDDH NAGAR (U.P.) - 201301**



TENDER DOCUMENTS

FOR

**EXECUTION AND HANDING OVER OF CIVIL WORKS OF OPEN AND CLOSED
STORE ALONG WITH APPROACH ROAD TO STORES FOR \pm 800 KV , 6000
MW HVDC BHADLA, RAJASTHAN**

CUSTOMER

POWERGRID CORPORATION OF INDIA LIMITED

TENDER SPEC. NO.: TBSM/HVDC BHADLA/CIVIL/STORE/TENDER/26-27

DATE: 15.05.2026

BHARAT HEAVY ELECTRICALS LIMITED
TRANSMISSION BUSINESS GROUP
SUBCONTRACTS MANAGEMENT

Sl. No.	Description	No. of Pages
1	Notice Inviting Tender	6
2	Project Information/ BHEL's Contacts	1
3	Offer forwarding letter / Tender submission letter	1
4	Declaration by Bidder	1
5	Declaration confirming knowledge about Site conditions	1
6	Authorization of representative for Online RA Process	1
7	List of key staff to be deputed at site	1
8	No deviation certificate	1
9	Declaration for relation in BHEL	1
10	Declaration Regarding Insolvency / Liquidation / Bankruptcy Proceedings	1
11	Declaration by Authorised Signatory of Bidder	1
12	Declaration regarding minimum local content	1
13	Declaration regarding no conflict of interest	1
14	Indemnity Bond	2
15	Pre-Qualifying Requirements	2
16	Format for e-payment	1
17	Health, Safety & Environment specification (Doc. No.: - TBG/HSE/NIT-01, Rev-03 Date 31.03.2026)	22
18	General Conditions of Contract for ETC Works (Document No. TB-ETC-GCC, Rev-02)	70
19	Annexure to conditions of contract for ETC Works	41
20	BHEL Conciliation Scheme	11
21	Bill of Quantity Cum price schedule (Annexure-I)	2
22	Price Bid Format: - To be filled by the Bidder Online through https://eprocurebhel.co.in	1
23	BOQ Annexures, Standard Notes for Scope, Scope Matrix, Technical Specification and Drawings	19



BHARAT HEAVY ELECTRICALS LIMITED

TRANSMISSION BUSINESS GROUP

SECTOR-16A, NOIDA -201301

e-mail: akmeena@bhel.in

NOTICE INVITING TENDER

Ref: - TBSM/HVDC BHADLA/CIVIL/STORE/TENDER/26-27

DATE: 15-05-2026

SUB: TENDER FOR "Execution and Handing Over of Civil works of Open and Closed Store along with approach road to stores for \pm 800 kV , 6000 MW HVDC BHADLA, Rajasthan".

Dear Sir/s,

1. Sealed tenders are invited for the following:

NAME OF WORK	TIME OF COMPLETION	EARNEST MONEY DEPOSIT	TENDER SUBMISSION DATE AND TIME	TENDER OPENING DATE & TIME
EXECUTION AND HANDING OVER OF CIVIL WORKS OF OPEN AND CLOSED STORE ALONG WITH APPROACH ROAD TO STORES FOR \pm 800 KV , 6000 MW HVDC BHADLA, RAJASTHAN	05 months from the date of LOI	NIL	29.05.2026 11.00 hrs.	29.05.2026 16.00 hrs. (Technical bid only)

2. Bidder has to submit offer directly through E-PROCUREMENT MODE. Bidder may visit <https://eprocurebhel.co.in>

Procedure for Submission of Tenders through e-tendering: The tender is also floated online through our E-Procurement Site <https://eprocurebhel.co.in> . The bidder may respond by submitting their offer online in our e-Procurement platform at <https://eprocurebhel.co.in>

Offers are invited in two-parts only.

Documents Comprising the e-Tender

The tender shall be submitted online EXCEPT EMD (which shall be submitted in physical form (as described in NIT cl. No.1) above as mentioned below:

a) Technical Bid (Un priced Tender)

All Technical details (e.g. Eligibility Criteria requested (as mentioned below)) should be attached in e-tendering module, failing which the tender stands invalid & may be REJECTED. Bidders shall furnish the following information along with technical tender (preferably in pdf format):

- i) Earnest money Deposit (EMD) furnished in accordance with NIT Clause
- ii) Technical Bid (without indicating any prices).

b) Price Bid:

- i) Prices are to be quoted in the attached Price Bid format online on e-tender portal.
- ii) The price should be quoted for the accounting unit indicated in the e-tender document.
- iii) Note: It is the responsibility of tenderer to go through the Tender document to ensure furnishing all required documents in addition to above, if any. Any deviation would

result in REJECTION of tender and would not be considered at a later stage at any cost by BHEL.

- iv) A person signing (manually or digitally) the tender form or any documents forming part of the contract on behalf of another shall be deemed to warrantee that he has authority to bind such other persons and if, on enquiry, it appears that the persons so signing had no authority to do so, the purchaser may, without prejudice to other civil and criminal remedies, cancel the contract and hold the signatory liable for all cost and damages.
 - v) A tender, which does not fulfil any of the above requirements and/or gives evasive information/reply against any such requirement, shall be liable to be ignored and rejected.
- c) Uploading of the price bid in prequalification bid or technical bid may RESULT IN REJECTION of the tender.
- d) Tenders shall be uploaded with all relevant PDF/zip format. The relevant tender documents should be uploaded by an authorized person having Class 3- SHA2- 2048 BIT-SIGNING & ENCRYPTION digital signature certificate (DSC).
3. **Tender must be accompanied by the prescribed amount of Earnest Money Deposit (EMD) in the manner described in “Annexure to the Conditions of contract for Civil work “which shall be part of the Technical Bid.**

In case of E-Tenders, no paper bids shall be accepted, therefore, the scanned copy of the Banker’s Cheque/ Demand Draft/ Pay Order/ Details of payment made through Electronic Fund Transfer/ Fixed Deposit Receipt (FDR) / Bank Guarantee should be uploaded in the E-Procurement Portal and hard copy of the same should reach to following address at before the due date and time of bid submission. BHEL shall not be responsible for postal or any other delays in this regard.)

To,

Ashok Kumar Meena
AGM (TBSM)
TRANSMISSION BUSINESS GROUP
BHARAT HEAVY ELECTRICALS LIMITED,
4th Floor, BHEL SADAN, Plot no.: - 25, Sector- 16A, Noida,
Distt. – Gautam Buddh Nagar, UP-201301
TELEPHONE: 0120-2218640, 9831038136
E-mail: akmeena@bhel.in

4. **Bidders may please note that no other mode of bid submission shall be considered for evaluation apart from Clause no. 02 to 03 mentioned above.**
5. The prospective bidders who have downloaded the tender documents from our website are requested to send their acknowledgement and willingness to participate in the tender to the undersigned, through fax or email.
6. Offers should be strictly in accordance with the Tender Specifications and General Instructions to Tenderer enclosed herewith.
7. “BHEL shall be resorting to Reverse Auction (RA) (Guidelines as available on www.bhel.com) for this tender. RA shall be conducted among the techno-commercially qualified bidders as per latest RA Guidelines.
- Price bids of all techno-commercially qualified bidders shall be opened and same shall be considered for RA. In case any bidder(s) do(es) not participate in online Reverse Auction, their price bid along with applicable loading, if any, shall be considered for ranking.”
8. The contractor shall give his explicit confirmation without any deviations to the HSE (Health, Safety and Environment) requirements as per enclosed specification No. TBSM/HSE/NIT-01, Rev-02 Date 31.01.2024. Contactors are also required to furnish details as per Annexure (HSE) to NIT along with their offer. Offers received without compliance & data about HSE requirements are liable to be rejected.

9. All documents submitted with the offer shall be signed and stamped in each page by authorized representative of the bidder.
10. Clarifications, if any, can be obtained from the undersigned but such requests should be submitted well before the due date for submission of tenders. Due date for submission and opening of tenders will not be extended on such grounds.
11. Please note that wherever there is a contradiction between the 'ANNEXURE TO CONDITIONS OF CONTRACT FOR CIVIL WORKS' and 'Annexure to conditions of contract for Civil Works' clauses shall be governing and binding on the contractor.
12. Drawings & FQP enclosed with the NIT (if provided) are for tender purpose only. Drawings & FQP may get change during execution stage and work to be carried as per latest RFC drawings & Field Quality Plan (FQP).
13. Construction/ RFC drawing/ Fronts shall be furnished progressively as per project requirement and no claim towards idling charges/ project overheads etc. borne by the contractor on account of non-availability of drawings/ fronts shall be entertained.
14. Completion period of the work has been envisaged under best possible conditions. Any changes/ deviation during execution shall be dealt as per relevant clauses mentioned in general/ special conditions of contract for Civil works.
15. *"In case this tender is awarded to first time contractor*, then the bidder shall be eligible to qualify for the next tender of similar work# of BHEL, TBG; only after successful executing of 50% (fifty percent) of this work prior to the date of next tender (in which bidder desires to quote) and on satisfactory performance feedback by BHEL site Incharge."*

** First time contractor: The bidders who have not successfully executed more than 50% (fifty percent) of awarded similar work by BHEL (TBG/ ISG/Power Sector/Any BHEL Unit) in last 5 years from date of NIT.*

The bidders who have taken any order from BHEL under 1st time category, and desires to further participate in BHEL tenders, needs to submit a certificate/ undertaking mentioning the reason of not executing 50% of awarded work, hence the criteria under 1st time bidder shall not be applicable to them. The certificate/ undertaking shall be duly certified by Site In charge of BHEL

Similar work: Similar to nature of work of the tender under consideration.

16. **Before submission of offer, the tenderer is advised to inspect the work & the environments and be well acquainted with the actual working and other prevalent conditions, facilities available, sourcing of material and labour, means of transport and access to site, accommodation, etc.** No claim will be entertained later on the grounds of lack of knowledge on any of these conditions/ resources.
17. The offers of the bidders who are under suspension as also the offers of the bidders, who engage the services of the banned firms, shall be rejected. The list of banned firms is available on BHEL web site www.bhel.com.
18. Integrity commitment, performance of the contract and punitive action thereof:
 - 18.1. Commitment by BHEL:

BHEL commits to take all measures necessary to prevent corruption in connection with the tender process and execution of the contract. BHEL will during the tender process treat all Bidder(s) in a transparent and fair manner, and with equity.
 - 18.2. Commitment by Bidder/ Supplier/ Contractor:
 - 18.2.1. The bidder/ supplier/ contractor commits to take all measures to prevent corruption and will not directly or indirectly influence any decision or benefit which he is not legally entitled to nor will act or omit in any manner which tantamount to an offence punishable under any provision of the Indian Penal Code, 1860 or any other law in force in India.

- 18.2.2. The bidder/ supplier/ contractor will, when presenting his bid, disclose any and all payments he has made, and is committed to or intends to make to agents, brokers or any other intermediaries in connection with the award of the contract and shall adhere to relevant guidelines issued from time to time by Govt. of India/ BHEL.
- 18.2.3. The bidder/ supplier/ contractor will perform/ execute the contract as per the contract terms & conditions and will not default without any reasonable cause, which causes loss of business/ money/ reputation, to BHEL.
- If any bidder/ supplier/ contractor during pre-tendering/ tendering/ post tendering/ award/ execution/ post-execution stage indulges in mal-practices, cheating, bribery, fraud or and other misconduct or formation of cartel so as to influence the bidding process or influence the price or acts or omits in any manner which tantamount to an offence punishable under any provision of the Indian Penal Code, 1860 or any other law in force in India, then, action may be taken against such bidder/ supplier/ contractor as per extant guidelines of the company available on [www. bhel.com](http://www.bhel.com) and/or under applicable legal provisions”.
19. Also, offer of the bidders who are suspended (under hold/ delist) for business dealings by BHEL, TBG shall not be considered. Please note that lifting/ restoration of suspension (Ban/Hold/ De-list) of business dealing is not automatic after expiry of specified suspension period. Hence, vendor shall be considered as suspended for business till suspension is lifted by BHEL in writing on specific request of the vendor as per extant guidelines.
20. BHEL Fraud Prevention Policy, "The Bidder along with its associate/ collaborators/ sub-contractors/ sub-vendors/ consultants/ service providers shall strictly adhere to BHEL Fraud Prevention Policy displayed on BHEL website <http://www.bhel.com> and shall immediately bring to the notice of BHEL Management about any fraud or suspected fraud as soon as it comes to their notice."
21. Offers will be scrutinized based on the qualifying requirements and only those who are technically and financially capable to execute the Job and who fulfil the Pre-Qualifying Requirements (PQR) are eligible to quote against the above NIT. However, final acceptance of the bidder/ offer shall be subject to acceptance of our customer.
22. The evaluation currency for this tender shall be INR.
23. The Submission of EMD is compulsory for subject tender **(if applicable)**.
24. In the course of evaluation, if more than one bidder happens to occupy L-1 status, effective L-1 will be decided by soliciting discounts from the respective L-1 bidders.
- In case more than one bidder happens to occupy the L-1 status even after soliciting discounts, the L-1 bidder shall be decided by toss/ draw of lots, in the presence of the respective L-1 bidder(s) or their representative(s).
- Ranking will be done accordingly. BHEL’s decision in such situations shall be final and binding.
25. Technical Bid will be opened in the office of undersigned. If required, technical discussions will be held with only those bidders who have taken any deviations. The price bids will be opened subsequently, after Technical Bids of all the bidders have been evaluated and freezed. Bidders should quote their most competitive rates as there will not be any price negotiation. However, if felt necessary by BHEL, price negotiation will be held with lowest bidder (L-1) only. **IT WOULD BE PREFERRED THAT YOUR OFFER IS WITHOUT ANY DEVIATION w.r.t. TENDER SPECIFICATIONS AND THE SAME MAY BE CLEARLY MENTIONED ON THE COVERING LETTER ACCOMPANYING THE TECHNICAL BID.** Offers with deviations are likely to be rejected.
26. In case any adverse information is received concerning performance, capability or conduct of the bidder after issue of tender enquiry, BHEL reserves the right to reject the offer at any stage as deemed fit.
27. **Integrity Pact (IP)- NA**
28. Any materials (if required) for Civil works have to be procured from Customer approved sources only. It will be the bidder’s responsibility to get the approval of materials and vendors for materials.

29. The purchase preference for central P.S.U.s shall be given as per the prevailing Government policy.
30. Work schedule and the deployment of manpower and T&P resources committed by the contractor in their offer, to match the scheduled completion, shall be submitted by contractor and mutually agreed with site In-charge immediately after the award of work. Further, the contractor shall mobilise at site within two weeks of award of work.
31. In case an offer is not being submitted by the prospective bidders against this tender, they may send their "regret" letter to this office, for information.
32. Details of qualifying work(s) executed by the bidder will be forwarded to the principal employer for verification of the work with respect to completion, commencement & completion date and value of the work executed. Performance feedback of the bidder will also be sought from the principal employer.
33. The bidder representative may be called for discussion with the committee. His originals may be verified by the committee. In addition to above their organisation chart and detail list of manpower, tools & plants and technical capability will be discussed and ascertained by the committee.
34. **Conflict of Interest among bidders/Agents: -**

*"A bidder shall not have conflict of interest with other bidders. Such conflict of interest can lead to anti-competitive practices to the detriment of Procuring Entity's interests. **The bidder found to have a conflict of interest shall be disqualified.** A bidder may be considered to have a conflict of interest with one or more parties in this bidding process, if:*

- a) *they have controlling partner (s) in common; **or***
- b) *they receive or have received any direct or indirect subsidy/ financial stake from any of them;*
or
- c) *they have the same legal representative/agent for purposes of this bid; **or***
- d) *they have relationship with each other, directly or through common third parties, that puts them in a position to have access to information about or influence on the bid of another Bidder; **or***
- e) *Bidder participates in more than one bid in this bidding process. Participation by a Bidder in more than one Bid will result in the disqualification of all bids in which the parties are involved. However, this does not limit the inclusion of the components/ sub-assembly/ Assemblies from one bidding manufacturer in more than one bid; **or***
- f) *In cases of agents quoting in offshore procurements, on behalf of their principal manufacturers, one agent cannot represent two manufacturers or quote on their behalf in a particular tender enquiry. One manufacturer can also authorise only one agent/dealer. There can be only one bid from the following:*
 1. *The principal manufacturer directly or through one Indian agent on his behalf;*
and
 2. *Indian/foreign agent on behalf of only one principal;*
or
 3. *A Bidder or any of its affiliates participated as a consultant in the preparation of the design or technical specifications of the contract that is the subject of the Bid; **or***
 4. *In case of it holding company having more than one independently manufacturing units, or more than one unit having common business ownership/management, only one unit should quote. Similar restrictions would apply to closely related sister companies. Bidders must proactively declare such sister/ common business/ management units in same/ similar line of business. "*

35. GRIEVANCE REDRESSAL MECHANISM:

"To promote transparency and ensure fair treatment of all bidders, a structured Grievance Redressal Mechanism is in place to address any concerns or issues arising during the tendering process or in subsequent business dealings with the company.

Suppliers/Contractors are requested to follow the below escalation process for grievance resolution:

1. First Level: Any grievance should initially be addressed to the designated Dealing Officer, whose contact details are as follows:

(i) During tendering Stage –

Ashok Kumar Meena
AGM/TBSM, TBG, BHEL
Email: akmeena@bhel.in
Phone: 0120-2218640

(ii) During execution of work –

Anand Kumar Tripathi
General Manger (TBG- Commercial & HVDC)
TRANSMISSION BUSINESS GROUP,
Plot No. 25, Sector-16A, Noida,
Distt. Gautambudh Nagar, UP-201301
PHONE: 9650026888
E-mail: anand@bhel.in

2. Second Level: If the issue remains unresolved, it may be escalated by lodging a formal grievance through the SUVIDHA Portal: <https://suvidha.bhel.in/suvidha/>. Responses will be provided in accordance with the defined escalation matrix.””

Thanking you,

Yours faithfully,
For and on behalf of BHEL,

(Ashok Kumar Meena)
AGM /TBSM

PROJECT INFORMATION

1.0 CUSTOMER:

M/s POWERGRID CORPORATION OF INDIA LIMITED

2.0 PROJECT LOCATION AND DETAILS:

TENDER FOR "EXECUTION AND HANDING OVER OF CIVIL WORK OF OPEN AND CLOSED STORE ALONG WITH APPROACH ROAD TO STORES FOR ± 800 KV , 6000 MW HVDC BHADLA, RAJASTHAN

SITE ADDRESS:

Bhadla HVDC substation, NH 911, Near Baba Ramdevji Mandir, PO- BAP, Distric - Phalodi, Rajasthan-342307, India

3.0 CONTACT PERSON: FOR CONTRACTUAL ISSUES

Ashok Kumar Meena
AGM (TBSM)
SUBCONTRACTS MANAGEMENT,
TRANSMISSION BUSINESS GROUP,
Plot No. 25, Sector-16A, Noida,
Distt. Gautambudh Nagar, UP-201301

PHONE: 0120-674-8545/ 9831038136

E-mail: akmeena@bhel.in

CONTACT PERSON: FOR ENGINEERING ISSUES

Vishal Garg
Sr Manager (TBEM-Civil)
TRANSMISSION BUSINESS GROUP,
Plot No. 25, Sector-16A, Noida,
Distt. Gautambudh Nagar, UP-201301

PHONE: 0120- 221-8929 / 9028561000

E-mail: vishal_garg@bhel.in

CONTACT PERSON: FOR CONTRACT EXECUTION ISSUES

ANAND TRIPATHI
General Manger (TBG- Commercial & HVDC)
TRANSMISSION BUSINESS GROUP,
Plot No. 25, Sector-16A, Noida,
Distt. Gautambudh Nagar, UP-201301

PHONE: 9650026888

E-mail: anand@bhel.in

(TO BE FILLED BY TENDERER OVER THEIR LETTERHEAD)

OFFER FORWARDING LETTER / TENDER SUBMISSION LETTER

REF:

DATE:

To,
AGM/TBSM
Transmission Business Group,
Bharat Heavy Electricals Limited,
6th Floor, BHEL SADAN,
Plot No. 25, Sector-16A, Noida,
Distt. – Gautam Buddha Nagar, UP-201301

Dear Sir,

Sub: Submission of Offer against following tender specification No. :

TENDER REF NO: TBSM/HVDC BHADLA/CIVIL/STORE/TENDER/26-27

DATE: 15-05-2026

"I/We hereby offer to carry out the work detailed in the Tender Specification issued by Bharat Heavy Electricals Limited, Transmissin Business Group (TBG) in accordance with the terms and conditions thereof. I/We have carefully perused the following listed documents connected with the above work and agree to abide by the same.

1. Amendments/Clarifications/Corrigenda/Errata/etc., issued in respect of the Tender documents by BHEL
2. Notice Inviting Tender (NIT)
3. Price Bid
4. Technical Specifications
5. Special Conditions of Contract
6. General Conditions of Contract
7. Forms and Procedures

Should our Offer be accepted by BHEL for Award, I/we further agree to furnish 'Security Deposit' for the work as provided for in the Tender Conditions within the stipulated time as may be indicated by BHEL. I/We further agree to execute all the works referred to in the said Tender documents upon the terms and conditions contained or referred to therein and as detailed in the appendices annexed thereto.

I/We have deposited/depositing herewith the requisite documents furnished in the Check List."

Place :
Date :

Signature of the Authorized Signatory
Name:
Designation:

TO BE FILLED BY TENDERER OVER THEIR LETTERHEAD

ANNEXURE – X

Ref: - TBSM/HVDC BHADLA/CIVIL/STORE/TENDER/26-27

DATE: 15-05-2026

**SUB: Tender for “EXECUTION AND HANDING OVER OF CIVIL WORKS OF OPEN AND CLOSED STORE ALONG WITH APPROACH ROAD TO STORES FOR ± 800 KV , 6000 MW HVDC BHADLA, RAJASTHAN
.”**

It is certified that General Instructions and Information for tenderer have been read/ complied/ agreed to and each page of tender offer has been initialled and stamped.

Also It is being declares that we (.....Bidder Name) will not enter into any illegal or undisclosed agreement or understanding, whether formal or informal with other Bidder(s). This applies in particular to prices, specifications, certifications, subsidiary contracts, submission or non-submission of bids or any other actions to restrict competitiveness or to introduce cartelization in the bidding process.

In case, the Bidder is found having indulged in above activities, suitable action shall be taken by BHEL as per extant policies/ guidelines

(Signature of Tenderer)

Name and Designation of Authorised person (s)
Signing the tender on behalf of the tenderer

(TO BE FILLED BY TENDERER OVER THEIR LETTERHEAD)

ANNEXURE – Y

Ref: - TBSM/HVDC BHADLA/CIVIL/STORE/TENDER/26-27

DATE: 15-05-2026

SUB: Tender for “EXECUTION AND HANDING OVER OF CIVIL WORKS OF OPEN AND CLOSED STORE ALONG WITH APPROACH ROAD TO STORES FOR ± 800 KV , 6000 MW HVDC BHADLA, RAJASTHAN

Subject: Declaration confirming knowledge about Site conditions

I/We, _____ hereby declare and confirm that we have visited the Project Site with reference to above BHEL Tender Specifications and acquired full knowledge and information about the Site conditions including Wage structure, Industrial Climate, the Law & Order and other conditions prevalent at and around the Site. Also, we have acquired information about availability of manpower, construction material, water, electricity etc.

We further confirm that the above information is true and correct and we shall not raise any claim of any nature due to lack of knowledge of Site conditions.

I/We, hereby offer to carry out work as detailed in above mentioned Tender Specification, in accordance with Terms & Conditions thereof.

Site Visited Official Name & Contact Details:

(Signature of Tenderer)

Name and Designation of Authorised person (s)
Signing the tender on behalf of the tenderer

ANNEXURE – Z

Ref: - TBSM/HVDC BHADLA/CIVIL/STORE/TENDER/26-27

DATE: 15-05-2026

SUB: Tender for “EXECUTION AND HANDING OVER OF CIVIL WORKS OF OPEN AND CLOSED STORE ALONG WITH APPROACH ROAD TO STORES FOR ± 800 KV , 6000 MW HVDC BHADLA, RAJASTHAN.

Subject: Authorization of representative who will participate in the Online Reverse Auction Process:

1	NAME & DESIGNATION OF OFFICIAL	
2	POSTAL ADDRESS (COMPLETE)	
3	TELEPHONE NOS. (LAND LINE & MOBILE BOTH)	
4	FAX NO.	
5	E-MAIL ADDRESS	
6	NAME OF PLACE / STATE / COUNTRY, WHEREFROM S/HE WILL PARTICIPATE IN THE REVERSE AUCTION	

(TO BE FILLED BY TENDERER OVER THEIR LETTERHEAD)

LIST OF KEY-STAFF TO BE POSTED AT SITE AFTER RECEIPT OF LOI

Ref: - TBSM/HVDC BHADLA/CIVIL/STORE/TENDER/26-27

DATE: 15-05-2026

SUB : EXECUTION AND HANDING OVER OF CIVIL WORKS OF OPEN AND CLOSED STORE ALONG WITH APPROACH ROAD TO STORES FOR ± 800 KV , 6000 MW HVDC BHADLA, RAJASTHAN

To,
AGM/TBSM
Transmission Business Group,
Bharat Heavy Electricals Limited,
6th Floor, BHEL SADAN,
Plot No. 25, Sector-16A, Noida,
Distt. – Gautam Buddha Nagar, UP-201301

Subject: LIST OF KEY-STAFF TO BE POSTED AT EACH SITE AFTER RECEIPT OF LOI

"Dear Sir,
With reference to above, this is to confirm that we shall depute the following main staff (Minimum) for above referred work at project site permanently till completion of work.."
"

	Site Incharge	Supervisor-1	Supervisor-2	Safety Engineer
1	Name			
2	Qualification			
3	Experience (in years)			
4	Age			

We assure that above are the minimum staff we shall depute at site. In case of further requirement, we shall depute additional staff as per work requirement and as per instruction of BHEL site incharge.

Thanking you,

(Signature of Tenderer)

Name and Designation of Authorised person (s)
Signing the tender on behalf of the tenderer

FORMAT OF NO DEVIATION CERTIFICATE

(To be submitted in the bidder's letter head)

REF:

Date.....

**BHARAT HEAVY ELECTRICALS LIMITED,
TRANSMISSION BUSINESS GROUP,
4TH Floor, BHEL SADAN,
Plot No- 25, Sector- 16A, Noida,
Distt. Gautambudh Nagar, UP-201301**

SUB: EXECUTION AND HANDING OVER OF CIVIL WORKS OF OPEN AND CLOSED STORE ALONG WITH APPROACH ROAD TO STORES FOR \pm 800 KV , 6000 MW HVDC BHADLA, RAJASTHAN

Tender Ref.: TBSM/HVDC BHADLA/CIVIL/STORE/TENDER/26-27

DATE: 15-05-2026

Dear Sir,

With reference to above, this is to confirm that as per tender conditions, we have visited subject site before submission of our offer and noted the job content & site conditions etc.

We also confirm that we have not changed / modified the tender documents as appeared in the website and in case of observance at any stage, it shall be treated as null and void. We hereby confirm that we have not taken any deviation from tender clauses together with other references as enumerated in the above referred NIT and we hereby convey our unqualified acceptance to all terms and conditions as stipulated in the tender and NIT. In the event of observance of any deviation in any part of our offer at a later date whether implicit or explicit, the deviations shall stand null & void.

We confirm to have submitted offer strictly in accordance with tender instructions.

Thanking you,

Yours faithfully,

(Signature, date & seal of authorized representative of the bidder)

DECLARATION FOR RELATION IN BHEL

(To be typed and submitted in the Letter Head of the Company/Firm of Bidder failing which the offer of Bidder is liable to be summarily rejected)

Ref:

Date.....

**To,
AGM/TBSM
Transmission Business Group,
Bharat Heavy Electricals Limited,
4th Floor, BHEL SADAN,
Plot No. 25, Sector-16A, Noida,
Distt. - Gautam Buddh Nagar, UP-201301**

Dear Sir,

Sub: Declaration for relation in BHEL

**Ref: 1) NIT/Tender Specification No.: TBSM/HVDC BHADLA/CIVIL/STORE/TENDER/26-27
DATE: 15-05-2026**

I/We hereby submit the following information pertaining to relation/relatives of Proprietor/
Partner(s)/Director(s) employed in BHEL

Tick (√) any one as applicable:

1. The Proprietor, Partner(s), Director(s) of our Company/Firm DO NOT have any relation or
relatives employed in BHEL

OR

2. The Proprietor, Partner(s), or Director(s) of our Company / Firm HAVE relation / relatives
employed in BHEL and their particulars are as below:

a)

b)

Signature of the Authorized Signatory

Note:

- 1) Attach separate sheet, if necessary.
- 2) If BHEL Management comes to know at a later date that the information furnished by the Bidder is false, BHEL reserves the right to take suitable against the Bidder/ Contractor.

(TO BE FILLED BY TENDERER OVER THEIR LETTERHEAD)

DECLARATION REGARDING INSOLVENCY / LIQUIDATION / BANKRUPTCY PROCEEDINGS

REF:

DATE:

To,
AGM/TBSM
Transmission Business Group,
Bharat Heavy Electricals Limited,
6th Floor, BHEL SADAN,
Plot No. 25, Sector-16A, Noida,
Distt. – Gautam Buddh Nagar, UP-201301

Dear Sir,

Sub: Declaration Regarding Insolvency / Liquidation / Bankruptcy Proceedings

Reference Documents :

Ref: TBSM/HVDC BHADLA/CIVIL/STORE/TENDER/26-27

DATE: 15-05-2026

"I/We, _____
declare that, I/We am/are not under insolvency resolution process or liquidation or Bankruptcy Code Proceedings (IBC) as on date, by NCLT or any adjudicating authority/authorities, which will render us ineligible for participation in this tender.
Thanking you, "

Date :

(Signature of Tenderer)

Place :

Name and Designation of Authorised person (s)

Signing the tender on behalf of the tenderer

DECLARATION BY AUTHORISED SIGNATORY OF BIDDER

(To be typed and submitted in the Letter Head of the Company/Firm of Bidder)

To,

**AGM/TBSM
Transmission Business Group,
Bharat Heavy Electricals Limited,
4th Floor, BHEL SADAN,
Plot No. 25, Sector-16A, Noida,
Distt. – Gautam Buddh Nagar, UP-201301**

Dear Sir,

Sub: Declaration by Authorized Signatory regarding Authenticity of submitted documents.

Ref: 1) NIT/Tender Specification No: TBSM/HVDC BHADLA/CIVIL/STORE/TENDER/26-27

DATE: 15-05-2026

2) All other pertinent issues till date

I/We, hereby certify that all the documents submitted by us in support of possession of “Qualifying Requirements” are true copies of the original and are fully compliant required for qualifying / applying in the bid and shall produce the original of same as and when required by Bharat Heavy Electricals Limited.

I / We hereby further confirm that no tampering is done with documents submitted in support of our qualification as bidder. I / We understand that at any stage (during bidding process or while executing the awarded works) if it is found that fake / false / forged bid qualifying /supporting documents / certificates were submitted, it would lead to summarily rejection of our bid / termination of contract. BHEL shall be at liberty to initiate other appropriate actions as per the terms of the Bid / Contract and other extant policies of Bharat Heavy Electricals Limited.

Yours faithfully,

(Signature, Date & Seal of Authorized
Signatory of the Bidder)

Date:

Place

Annexure-MII

DECLARATION REGARDING MINIMUM LOCAL CONTENT IN LINE WITH REVISED PUBLIC PROCUREMENT (PREFERENCE TO MAKE IN INDIA), ORDER 2017 DATED 04TH JUNE, 2020 AND SUBSEQUENT ORDER(S).

(To be typed and submitted in the Letter Head of the Entity/Firm providing certificate as applicable)

To,
AGM/TBSM,
Bharat Heavy Electricals Limited, TBG, TBSM,
4th Floor, BHEL SADAN, Plot No. 25, Sector-16A, Noida, U.P.-201301

Dear Sir,
Sub: Declaration reg. minimum local content in line with Public Procurement (Preference to Make in India), Order 2017-Revision, dated 04th June, 2020 and subsequent order(s).

Ref:

1) NIT/Tender Specification No: **TBSM/HVDC BHADLA/CIVIL/STORE/TENDER/26-27**

DATE: 15-05-2026

2) All other pertinent issues till date

We here by certify that the items/works/services/ offered by (specify the name of the organization here) has a local content of _____ % and this meets the local content requirement for – Class 1 Local supplier/ Class II local supplier** as defined in Public Procurement (Preference to Make in India), Order 2017-Revision dated 04.06.2020 issued by DPIIT and subsequent order(s).

The details of the location(s) at which the local value addition is made are as follows:

- | | |
|----------|----------|
| 1. _____ | 2. _____ |
| 3. _____ | 4. _____ |

Thanking you,

Yours faithfully,

(Signature, Date & Seal of Authorized Signatory of the Bidder)

** - Strike out whichever is not applicable.

Note:

1. Bidders to note that above format Duly filled & signed by authorized signatory, shall be submitted.
2. In case the bidders quoted value is excess of 10 crores, the authorized signatory for this declaration shall necessarily be the statutory auditor or cost auditor of the company (in the case of companies) or a practising cost accountant or practicing chartered accountant (in respect of suppliers/contractors other than companies).
3. In the event of false declaration, actions as per the above order and as per BHEL Guidelines shall be initiated against the bidder.

(TO BE FILLED BY TENDERER OVER THEIR LETTERHEAD)

DECLARATION REGARDING NO CONFLICT OF INTEREST

Ref: - TBSM/HVDC BHADLA/CIVIL/STORE/TENDER/26-27

DATE: 15-05-2026

EXECUTION AND HANDING OVER OF CIVIL WORKS OF OPEN AND CLOSED STORE ALONG WITH APPROACH ROAD TO STORES FOR ± 800 KV , 6000 MW HVDC **BHADLA, RAJASTHAN.**

To,
AGM/TBSM
Bharat Heavy Electricals Limited,
6th Floor, BHEL SADAN,
Plot No. 25, Sector-16A, Noida,
Distt. – Gautam Buddh Nagar, UP-201301

Dear Sir,

Subject: DECLARATION REGARDING NO CONFLICT OF INTEREST

Reference Documents :

NIT / TENDER NO. TBSM/HVDC BHADLA/CIVIL/STORE/TENDER/26-27
2026

DATE: 15-05-
2026

"We, M/s. _____ a company/Firm incorporated under the laws of the country having its registered office at _____, hereby declare and confirm the following in connection with the tender No.

We confirm that no conflict of interest exists in our participation in this tender.

None of our personnel, agents, or subcontractors have any personal, financial, or business relationship with BHEL's employees or officials involved in this tender process that could constitute a conflict of interest. None of our directors, employees, agents, or allied firms have been involved in need assessment, procurement planning, or evaluation of this tender.

If we are acting as an agent/distributor, we confirm that we do not represent more than one manufacturer in this tender and that the OEM is not bidding separately. We are not participating in more than one bid in this tender. *

*Participating in any capacity by a bidder (including the participation of a Bidder as a partner/JV member or sub-contractor in another bid or vice-versa) in more than one bid shall result in the disqualification of all bids in which he is a party. However, this does not limit the participation of an entity as a sub-contractor in more than one bid if he is not bidding independently in his own name or as a member of a JV.

We understand that false declarations may result in disqualification or legal action."""

"Thanking you,
Yours faithfully, "

(Signature, Date & Seal of Authorized Signatory of the Bidder)

Note:

"1) Attach separate sheet, if necessary. "

INDEMNITY BOND

(To be typed and submitted in the Letter Head of the Company/Firm of Bidder)

This Indemnity Bond executed by <_____ name of company> having their Registered Office at <_____> in favour of M/s Bharat Heavy Electricals Limited, a Company incorporated under the Companies Act, 1956, having its Registered Office at BHEL House, Siri Fort, Asiad, New Delhi - 110049 through its unit - TBG, 5th Floor, BHEL Sadan, Plot No. 25, Sector-16A, Noida-201301 (UP). (Hereinafter referred to as the Company)

And whereas the Company has entered into a Contract with M/s _____, the executants of this Deed (hereinafter referred to as the Contractor) as its contractor in respect of the work of “ _____ ”.

AND WHEREAS under the provisions of GCC further stipulates that the Contractor shall indemnify the Company against all claims of whatever nature arising during the course of execution of Contract including defects liability period of <____Months> i.e till <_____>

Now this deed witness that in case the Company is made liable by any Authority including Court to pay any claim or compensation etc. in respect of all labourers or other matters at any stage under or relating to the Contract with the Contractor, the Contractor hereby covenants and agrees with the Company that they shall indemnify and reimburse the Company to the extent of such payments and for any fee, including litigation charges, lawyers' fees, etc, penalty or damages claimed against the Company by reason of the Contractor falling to comply with Central/States Laws, Rules etc, or his failure to comply with Contract (including all expenses and charges incurred by the Company).

The Contractor further indemnifies the Company for the amount which the Company may be liable to pay by way of penalty for not making deductions from the Bills of the Contractor towards such amount and depositing the same in the Government Treasury.

The Contractor further agree that the Company shall be entitled to withhold and adjust the Security Deposit and/or withhold and adjust payment of Bills of Contractor pertaining to this Contract against any payment which the Company has made or is required to make for which the Contractor is liable under the Contract and that such amount can be withheld, adjusted by the Company till satisfactory and final settlement of all pending matters and the Contractor hereby gives his consent for the same.

The Contractor further agrees that the terms of indemnity shall survive the termination or completion of this contract.

The contractor further agrees that the liability of the contractor shall be extended on actual basis notwithstanding the limitations of liability clause, in respect of :

1. breach of terms of contract by the contractor
2. breach of laws by the contractor
3. breach of Intellectual property rights by the contractor
4. breach of confidentiality by the contractor

Nothing contained in this deed, shall be construed as absolving or limiting the liability of the Contractor under said Contract between the Company and the Contractor. That this Indemnity Bond is irrevocable and the condition of the bond is that the Contractor shall duly and punctually comply with the terms and the conditions of this deed and contractual provisions to the satisfaction of the Company.

In witness where of M/s _____ these presents on the day, month and year first, above written at _____ by the hand of its signatory Mr. _____.

Signed for and on behalf of
M/s _____

Witness:

- 1.
- 2.

BHARAT HEAVY ELECTRICALS LIMITED
TRANSMISSION BUSINESS GROUP, NOIDA
PRE-QUALIFYING REQUIREMENTS

REF.: TBSM/HVDC BHADLA/CIVIL/STORE/TENDER/26-27

DATE: 15-05-2026

SUB: TENDER FOR “Execution and Handing Over of Civil works of Open and Closed Store along with approach road to stores for ± 800 kV , 6000 MW BHADLA, RAJASTHAN

Tenders (Under two-part bid system) are invited from competent contractors for subject works. Only those who are technically and financially capable to execute the Job and who fulfil the Pre-Qualifying Requirements [PQR] given under are eligible to quote against the above NIT. Tenderers should submit their offer as per the procedure specified in tender documents. The PQR of contractor for tender submission shall be as under:

Sl. No.	Criteria	Description
A	Turn Over	<p>Bidders should have a minimum average annual turnover (Annual Gross Revenue from operations/ Gross operating income as incorporated in the profit & loss account excluding Other Income) of ₹ ₹ 17,80,849/-for last three fin. Years i.e. 36 months (2022-23,2023-24 & 2024-25 OR 2023-24, 2024-25 & 2025-26) and should submit audited balance sheet and Profit & Loss Account Sheet of these years.</p> <p>The audited financial statements must be signed by the owner and the auditor. Auditors seal, Name, Membership No., Firm Registration No. & firm name (if applicable), UDIN and the capacity in which he is signing (Proprietor/Partner), must be mentioned on the Profit & Loss A/c and Balance Sheet.</p> <p>In case of proprietorship and partnership firms where Audited Profit & Loss A/c and Balance Sheet is not mandatory as per extant rules, CA certificate certifying turnover and profit for the required financial years must be submitted. CA certificate must be on his letter head mentioning his/her name, Membership No., Firm Registration No. & firm name (if applicable), UDIN, capacity in which he is signing (Proprietor/Partner), date and place of signing.</p>
B	Profit & Networth	<p>Bidder should have earned profit in at least one financial year during the period of last three Financial Years as per Sl. No. A above</p> <p>and</p> <p>Net worth of the Bidder based on the latest Audited Accounts as furnished for ‘A’ above should be positive. Net worth = Paid up share capital + Reserves. (Net worth is required to be evaluated in case of companies)</p>
C	Similar Work	<p>Bidder should have successfully executed <u>civil works of switchyard or Power Plant or industry (All industry excluding Residential, Irrigation & Road work) involving predominantly concrete work</u> during last seven years ending on 30.04.2026 and should be either of the following:</p>

		<p>i. Three similar jobs costing (except service tax/GST) not less than <u>₹ 23,74,465.00</u> each.</p> <p style="text-align: center;">OR</p> <p>ii. Two similar jobs costing (except service tax/GST) not less than <u>₹ 29,68,082.00</u> each.</p> <p style="text-align: center;">OR</p> <p>iii. One similar job costing (except service tax/GST) not less than <u>₹ 47,48,930.00</u></p>
--	--	--

Note:

1. The Bidder shall submit the Contract Agreement/Work Order/LOI, BOQ and Performance/completion/execution certificate issued by customer/contractor along with technical bid in support of qualification. In order to technically qualify in this tender, bidder should meet all criteria i.e. A, B & C mentioned above.
2. If the job is completed in the last seven-years period, as specified above, even if it has been started earlier, the same will also be considered meeting the qualifying requirements.
3. Consortium/ JV bidding is not allowed in this NIT.
4. BHEL reserves the right to:
 - (a) Accept or reject any bid received at its discretion without assigning any reasons whatsoever.
 - (b) Postpone the above-mentioned date, split and distribute the work among more than one bidder without assigning any reason whatsoever.
 - (c) May ask for further qualification during techno commercial scrutiny of bids received.
 - (d) May ask for further proofs including TDS certificates/ Form 26AS/ Final bill/ payment detail for the said job for cross- verification.
5. BHEL shall not be responsible for any delay, loss, damage for bid documents sent by post.
6. BHEL shall not be liable for any expenses incurred by bidder in preparation of bid irrespective of whether it is accepted or not.
7. Quotations received from bidders who do not fulfil the PQR shall be summarily rejected without any further evaluation and information to bidders.
8. Canvassing i.e. soliciting favour, seeking advantage etc. in any form is strictly prohibited and any bidder found to have engaged in canvassing shall be liable to have his bid rejected summarily.
9. If the bidder deliberately gives any wrong information in his tender to create in circumstances for the acceptance to his bid, BHEL reserves the right to reject such application.
10. Bidder's selection is subject to approval of BHEL's customer for this work. The approval/acceptance of bidders from Customer is mandatory requirement for subject tender.
11. All corrigenda, addenda, amendments and clarifications to this Tender will be hosted in web page, www.bhel.com and <https://eprocurebhel.co.in> and not in the newspaper. Bidders shall keep themselves updated with all such amendments.

NIT HSE SPECIFICATIONS



Health Safety and Environment Management System

TRANSMISSION BUSINESS GROUP, NOIDA



BHARAT HEAVY ELECTRICALS LIMITED

	Transmission Business Group Department of Health, Safety & Environment, Noida	Doc No. TBG/HSE/NIT-01 Rev No. : 03 Date: 31.03.26
	NIT HSE Specifications	Page- 1 of 22



Transmission Business Group, Noida

DOCUMENT CONTROL			
Document number:	TBG/HSE/NIT-01		
Issue number:	00	Issue date:	08.01.2020
Revision number:	01	Revision date :	22.10.2021
Revision number:	02	Revision date :	31.01.2024
Revision number:	03	Revision date :	31.03.2026
	Prepared by		Approved and Issued for use by
Name	Arvind Kumar Pandey		
Designation	Sr. Engineer		Head/HSE
Signature	-sd-		
Date	31.03.2026		
Doc. copy issue no. :		Doc. copy issue date :	
Issued to :	Name	Designation	Signature
Issued by :	Name	Designation	Signature

BHARAT HEAVY ELECTRICALS LIMITED

TRANSMISSION BUSINESS GROUP

	Transmission Business Group Department of Health, Safety & Environment, Noida	Doc No. TBG/HSE/NIT-01 Rev No. : 03 Date: 31.03.26
	NIT HSE Specifications	Page- 2 of 22

Preamble: BHEL-TBG, through its long experience and policies, has developed a strong culture of prioritizing societal well-being, environmental protection, and the occupational health and safety of its workforce. Transparency in all business dealings is also a hallmark of TBG. In line with this culture, this NIT HSE Specification provides a concise glimpse of TBG's HSE requirements, drawn from the detailed document '*HSE Plan for Site Operations (for Sub-contractors), Doc. No. HSEP-14*'. While the complete HSE provisions with applicable formats are covered in HSEP-14, this annexure serves as a primary reference to highlight the major compliances that must 100% be adhered to by the successful bidder during contract execution. All interested bidders are advised to carefully review these HSE specifications before quoting.

1. BHEL HSE Policy

(Rev-03)



स्वास्थ्य, सुरक्षा एवं पर्यावरण नीति

बीएचईएल अपने कर्मचारियों और संगठन के लिए काम करने वाले अन्य लोगों के व्यावसायिक स्वास्थ्य और सुरक्षा को सुनिश्चित करने और सक्रिय नेतृत्व के माध्यम से अपनी गतिविधियों, उत्पादों और सेवाओं के पर्यावरणीय पदचिह्नों को कम करने एवं आवश्यक संसाधनों की उपलब्धता सुनिश्चित करने के लिए प्रतिबद्ध है। इसके अलावा, हम अपने पर्यावरण, सामाजिक और प्रशासन (ESG) प्रदर्शन को निम्नलिखित द्वारा लगातार बेहतर बनाने के लिए प्रतिबद्ध हैं:

- शून्य क्षति के लक्ष्य को प्राप्त करने के उद्देश्य से सुरक्षा संस्कृति को मजबूत करना,
- प्रदूषण की रोकथाम, जैव विविधता और पारिस्थितिकी तंत्र की सुरक्षा और जलवायु परिवर्तन शमन (mitigation) और अनुकूलन सहित पर्यावरण की सुरक्षा के लिए गतिविधियों को और सुदृढ़ता से करना,
- 2047 तक शुद्ध शून्य (Net Zero) उत्सर्जन (स्कोप 1 और स्कोप 2) प्राप्त करने के लिए कदम उठाना,
- संसाधनों का संरक्षण करना तथा उनका उपयोग कम करना / पुनर्चक्रण करना / पुनः उपयोग करने (Reduce / Recycle / Reuse) के दृष्टिकोण के आधार पर स्थायी अपशिष्ट प्रबंधन प्रथाओं को अपनाना,
- उन्मूलन / प्रतिस्थापन / कमी / नियंत्रण (elimination / substitution / reduction / control) दृष्टिकोण के माध्यम से पर्यावरणीय प्रभावों तथा व्यावसायिक स्वास्थ्य एवं सुरक्षा जोखिमों का प्रबंधन करना,
- लागू विधानों, विनियमों तथा बीएचईएल प्रबंधन प्रणालियों का अनुपालन सुनिश्चित करना,
- व्यावसायिक निर्णयों, उत्पादों की ब्रह्मचरणा एवं डिजाइन, संयंत्रों, प्रौद्योगिकियों एवं सेवाओं के चयन, खरीद तथा आउटसोर्स प्रक्रियाओं में उपयुक्त व्यावसायिक स्वास्थ्य, सुरक्षा एवं पर्यावरण मानदंडों को शामिल करना,
- एच.एस.ई. प्रबंधन प्रणाली (एच.एस.ई.एम.एस.) में सुधार के लिए श्रमिकों एवं अन्य हितधारकों से परामर्श एवं भागीदारी सुनिश्चित करना तथा उनकी प्रासंगिकता, उपयुक्तता एवं प्रभावशीलता सुनिश्चित करने के लिए समय-समय पर इस नीति एवं एच.एस.ई.एम.एस. की समीक्षा करना,
- हमारे कार्यस्थलों पर कार्यरत व्यक्तियों को उचित संरचित प्रशिक्षण प्रदान करना तथा एच.एस.ई. मुद्दों पर ग्राहकों, ठेकेदारों एवं आपूर्तिकर्ताओं के बीच जागरूकता को बढ़ावा देना,
- बीएचईएल के भीतर इस नीति का संचार करना तथा ड्यूक पक्षों को इसे उपलब्ध कराना।

(यह नीति अभ्यक्ष एवं प्रबंध निदेशक, बीएचईएल द्वारा अनुमोदित है)



भारत हेवी इलेक्ट्रिकल्स लिमिटेड



Health, Safety & Environment Policy

BHEL is committed to ensure occupational health & safety of its employees and other people working for the organisation and minimising the environmental footprints of its activities, products and services through active leadership and ensuring availability of required resources. Further, we commit to continually improve our Environmental, Social and Governance (ESG) performance by:

- Strengthening safety culture with an objective to attain Zero Harm,
- Taking up activities for protection of the environment, including prevention of pollution, protection of biodiversity & ecosystems and climate change mitigation & adaptation,
- Taking steps for attaining Net Zero emissions (Scope 1 and Scope 2) by 2047,
- Conserving resources and adopting sustainable waste management practices based on Reduce / Recycle / Reuse approach,
- Managing Environmental impacts and Occupational Health & Safety risks through elimination / substitution / reduction / control approach,
- Ensuring compliance with applicable legislations, regulations and BHEL Management Systems,
- Incorporating appropriate Occupational Health, Safety and Environment criteria into business decisions, conceptualisation and design of products, selection of plants, technologies and services, procurements and in outsourced processes,
- Ensuring consultation and participation of workers and other stakeholders for improvements in the HSE Management System (HSEMS) and reviewing periodically this policy and HSEMS to ensure their relevance, appropriateness and effectiveness,
- Imparting appropriate structured training to persons engaged at our workplaces and promoting awareness amongst customers, contractors and suppliers on HSE issues,
- Communicating this policy within BHEL and making it available to interested parties.

(This policy bears the approval of Chairman & Managing Director, BHEL)



Bharat Heavy Electricals Limited

	Transmission Business Group Department of Health, Safety & Environment, Noida	Doc No. TBG/HSE/NIT-01 Rev No. : 03 Date: 31.03.26
	NIT HSE Specifications	Page- 3 of 22

2. Legal/Statutory Compliances:

- a. **Statutory Provisions:** All the sub-contractors are to comply with client specific rules and procedures, the National legislations and codes, in particular the following or their revised versions:

S.no.	Acts/Rules Name	S.no	Acts/Rules Name
1	The Code on Wages, 2019	13	Contractor labour Act, 1970 (Regulation and abolition) (4)
2	The Industrial Relations Code, 2020	14	Provident fund Act, 1952 (3)
3	The Code on Social Security, 2020	15	Payment of gratuity Act, 1972 (3)
4	The Occupational Safety, Health and Working Conditions Code, 2020	16	Indian Explosives Act and the explosives Rules 2008
5	Buildings and Other Construction Workers Welfare Act, 1996 (4)	17	The Gas Cylinder Rules, 2016, Static and Mobile Pressure Vessels (Unfired) Rules 2016
6	The Inter-State Migrant Workmen (Regulation of Employment and Conditions of Service) Act, 1979 (4)	18	The Indian Electricity Act 2003 and Indian Electricity Rules 2005
7	Employee's Compensation Act, 1923 (4)	19	The Atomic Energy Act, 2015
8	Payment of wages Act, 2017 Equal remuneration Act, (1)	20	The atomic energy (Radiation Protection) Rules. 2004
9	Minimum wages Act.1948 (1)	21	National Fire Protection Association (NFPA),
10	Maternity benefit amendment act 2017 (3)	22	National Building Code of India 2016 etc.
11	The Factories Act 1948 (4)	23	The Environment Act 1986
12	Industrial dispute Act, 1947 (2)	24	Employers liability Act, 1938
13	Employees' State Insurance Act, 1948 (3)		

Note: Although new labour codes came into effect from 21.11.2025, yet till the OSHWC Code rules are fully notified and enforced by a State, BOCW Act, Contract Labour Act, Factories Act, etc., continue to apply in that State.

(Rev-03)

- b. **Indian Standard (IS) Codes related to HSE**

All the sub-contractors are to comply with client specific rules and procedures, the National legislations and codes in particular the following or their revised versions:

Srl	IS Code	Applies on
1	IS: 4081 -1986	Safety code for Blasting and Related Drilling operations
2	IS: 3764 -1992	Safety code for excavation work
3	IS: 5121 -1969	Safety code for piling and other deep foundations
4	IS: 2750 -1964	Specification for steel scaffoldings
5	IS: 3696 (Part-I)-1987	Safety code for scaffolds and Ladders: Part- I Scaffolds
6	IS: 3696 (Part-II) -1991	Safety code for scaffolds and Ladders: Part –II Ladders
7	IS: 4082 -1977	Recommendations on stacking and storage of construction materials at site (First revision)
8	IS: 4130-1976	Safety code for demolition of building (First revision)
9	IS: 4912-1978	Safety requirements for floor and wall openings, railings and toe boards (First revision)



NIT HSE Specifications

10	IS: 5916- 1970	Safety code for constructions involving use of hot bituminous materials
11	IS: 7205 -1974	Safety code for erection of structural steel work
12	IS: 7969 -1975	Safety code for handling and storage of building materials
13	IS: 8989 -1978	Safety code for erection of concrete framed structures
14	IS: 7293 -1974	Safety code for working with construction machinery
15	IS: 2212 -1991	Pipe lines –Identification –Colour code
16	IS: 5216 -1982	Recommendations on safety procedures & practices in Electrical works (Part -I & II)
17	IS: 875 -1964	Code of practice for structural safety of buildings and loading standards
18	IS: 10386 -1983	General aspects Part-1 -1983, Part-2 -1982, Part-6 -1983, Part-10 -1983- Amenities, Protective clothing and equipment, construction, storage, handling, detection and Safety measures for gases, chemicals and flammable liquids
19	IS: 10500-2012	Drinking water (Specification)
20	IS: 10291 -1982	Code of dress in civil engineering works
21	IS: 2925-1984	Safety helmets
22	IS: 1179-1967	Welding helmets
23	IS: 7524 -1979 (Part-I)	Safety goggles
24	IS: 9167 -1979	Ear muff /Ear plugs
25	IS: 6994 -1973 (Part-I)	Canvas hand gloves, Cotton hand gloves, Chrome leather gloves
26	IS: 4770 -1991	Rubber hand gloves tested for 15,000 volts
27	IS: 3521 -1999	Full body safety harness
28	IS: 11057 -1984	Specification for Industrial safety nets
29	IS: 13415 -1992	Protective Barriers in & around buildings (Code of safety)
30	IS: 13416 -1992	Preventive measures against Hazards at work places-Recommendations part-I Falling materials hazards Prevention part-I
31	IS: 13416 -1992	Preventive measures against Hazards at work places-Recommendations part-II Fall Prevention
32	IS: 15298 -2011 (Part 1&2)	Personal Protective Equipment -Safety shoes
33	IS: 12254 -1993	Poly vinyl chloride (PVC) industrial boots
34	IS: 5557:2004	Industrial and Protective Rubber knee and Ankle boots
35	IS: 2878 -2004	Co2 Type fire extinguisher
36	IS: 2171 -1999	Dry chemical powder fire extinguisher
37	IS: 13849 – 1993	Fire extinguisher for ABC fires
38	IS: 10204-2001	Mechanical Foam type extinguisher (Foam used shall conform to IS: 4989 -1974 and Co2 cartridge shall conform to IS: 4947 -1985)
39	IS: 3786 -1983	Methods for computation of Frequency rate and Severity rates for Industrial injuries and classification of Industrial accidents (First revision)

	Transmission Business Group Department of Health, Safety & Environment, Noida	Doc No. TBG/HSE/NIT-01 Rev No. : 03 Date: 31.03.26
	NIT HSE Specifications	Page- 5 of 22

3. Standard conditions of Subcontractor mobilization:

- Attend HSE familiarization program at TBG-HQ with his site management team. This will be a half day long awareness session on HSE requirements and compliances which the agency is supposed to fulfil during contract execution at site. The session shall be taken by TBG HSE department on intimation by TBSM. Minutes shall be prepared and shall be jointly signed
- Request for issuance of Form-V in their name from customer on behalf of BHEL
- Get the Labour license registration from concerned Labour office.
- Get the BOCW Registration done along with the labour license.
- Get the labourers registered under BOCW for benefits provided by the office.
- Maintain legal registers of labours as per BOCW requirement.
- Ensure payment of wages to labours not less than the current minimum wages applicable in the premises.
- Ensure PF deduction of labourers and submission of proof to BHEL office (Wage sheet, ECR & Challan copies) duly signed.
- Submit Labour Payment Certificate by 10th of Every month.
- File timely returns, get renewals done and submit a copy to BHEL office.
- Get Workmen's Compensation policy before the start of work, covering all the labourers and staff,
 - Policy should clearly mention the project name and location,
 - should be as per labour class and wage.
 - Should cover all the height workers with clear mention of Max. height.
 - Policy should be submitted to BHEL office and renewal before expiry.
- Issue employment card and identity card to every worker.
- Submit filled and signed RA bill checklist with each bill
- **Judiciously include the cost against safety related expenditures while bidding.**
- Subcontractor shall ensure submission of identity and address proof (preferably Aadhaar card/Voter card) and mobile number of the person to be mobilized at site well in advance.
- Subcontractor shall ensure that the person joining the site has no criminal record.
- Subcontractor shall also ensure the health check-up and induction training is done and the person is covered under employee's compensation insurance policy before he is actually engaged in the work.
- I-card in the prescribed format of BHEL/Customer is mandatory for all the persons of the subcontractor.
- If subcontractor fails to comply with any of the above provisions, BHEL shall not allow the person(s) to enter and work in the project premises. **(Rev-03)**

	Transmission Business Group Department of Health, Safety & Environment, Noida	Doc No. TBG/HSE/NIT-01 Rev No. : 03 Date: 31.03.26
	NIT HSE Specifications	Page- 6 of 22

4. Labour Welfare and Medical Facilities

a. Labour Welfare

1. Declaration of normal working hours and weekly off day, Payment day & intervals
2. Paid rest days & holidays.
3. Payment of overtime @ twice the normal wage rate.
4. No labour shall be allowed overtime >12 hrs/week, limited to 48 hrs/month.
5. Ensure to provide a dedicated rest and lunch area.
6. Separate Male/Female Toilets and Lavatories, clearly marked in local Language and provided with signage.
7. Cold and clean drinking water facility suitable to strength and near workplace
8. Creche for children of female workers as per BOCW requirements
9. Arranging labour accommodation in hygienic environment with the facilities of Water (Drinking, Sanitation), washing and bathing area, toilets in sufficient nos., clean and safe camps and surrounding, access road, well illuminated camp and roads, display of emergency contacts, transport facility, first aid centre, 24x7 Security etc.
10. Cooking and eating place to be maintained in hygienic condition
11. General awareness of health and hygiene.

b. Medical facilities and Health centres

- Availability of first aid box at every work location and agency office, with contents as per BOCW requirement.
- Emergency vehicle (four-wheeler) at work place with display of driver name and number
- Availability of stretchers in emergency vehicle and in office.
- Availability of trained first aider
- Medical check-up for all the supervisors and workers including cooks, at the time of induction and annually thereafter.
- Tetanus Vaccination for all in every six months.
- Identification and tie-up with nearby reputed hospital(s) and display of their contact number in Emergency contact list.

5. House Keeping & Storage

Housekeeping is a continuous process and is the part of work. Agencies shall maintain safe and presentable housekeeping all the time in their respective areas, common work locations and passage areas. Roads, passages, staircases, entrance/exit gates shall always be maintained obstruction free. No material shall be left or stacked at the roof edges. Agency shall make arrangements to remove scraps on regular basis and dispose them at a space provided by customer, clearly fenced and marked by the sub-contractor as “**SCRAP YARD**”. Suitable arrangement like dedicated housekeeping team and tractor/Farana should be identified for this work.

	Transmission Business Group Department of Health, Safety & Environment, Noida	Doc No. TBG/HSE/NIT-01 Rev No. : 03 Date: 31.03.26
	NIT HSE Specifications	Page- 7 of 22

Construction materials like shuttering materials, staging materials, cables, re-bars, cements bags, earthing flats and rods, FF pipes, surplus soil etc should be stored/stacked properly such that it should neither pose threat to safety of man nor should obstruct the free movement of man and machineries.

Every sub-contractor should have separate and well-maintained storage area for his own materials, T&Ps, PPEs and BHEL issued materials. Consumables like diesel, cotton, grease, oil, paint, admixtures and other fire potential materials should be stored separately with suitable firefighting facility.

Fire capacity of store area to be assessed and accordingly fire extinguishers shall be planned suiting the class and capacity of fire. Sand heaps may also be stacked in open store yards suitably to use in case of fires.

6. Site Safety

a. Induction and others safety trainings

Every sub-contractor shall make arrangement to provide induction training as per BHEL and/or customer requirement on a pre-approved and fixed module to all its new inductees irrespective of class or grade of appointment/hire. He shall also arrange the required facilities for induction training such as White board and marker, dummy with all PPEs, posters/banners with all the mandatory PPEs.

Sub-contractor shall also arrange for periodic trainings on fire-fighting, first aid, CPR, importance and use of PPEs, electrical safety, hot work safety, Height work safety, confined space, deep excavations and barricading, concreting work safety etc.

b. Deployment of safety personnel by subcontractor:

(Rev-03)

Deployment of safety personnel may be done as per the conditions prescribed below. This shall be payable at the approved basis of monthly rates as per **Annexure-1**. The qualification and experience criteria of each type of safety personnel is given in the table below:

Type	Safety personnel	Minimum Qualification & Experience	Remarks
A	Safety officer (To be deployed on need basis, as decided by BHEL site-charge.)	Qualification: A recognised Degree or Diploma in Engineering with a recognised Degree or Diploma in Industrial Safety. Experience: in building and other construction works. - Two years for degree in engineering - Five years for diploma in engineering	Applicable to all projects.
B	Safety supervisor (Max.-1 no.)	Qualification: A recognised Diploma in Engineering or B.Sc. Experience: Two years field experience in construction safety.	For POWERGRID Contracts only (where revised POWERGRID safety plan and GCC-2025

	Transmission Business Group Department of Health, Safety & Environment, Noida	Doc No. TBG/HSE/NIT-01 Rev No. : 03 Date: 31.03.26
	NIT HSE Specifications	Page- 8 of 22

			are applicable and when total number of workers exceeds 250)
C	Safety steward (Max.-2 nos.)	Qualification: An ITI or 10th pass, having undergone safety training programs and/or understands basic field safety requirements. Experience: field experience in construction safety. - One year for ITI certificate - Five years for 10th pass	For POWERGRID Contracts only (where revised POWERGRID safety plan and GCC-2025 are applicable- 01 safety steward up to 75 workers, second steward- when total number of workers exceed 75)

- a) The provision for deploying Safety Supervisors or Safety Stewards applies exclusively to **POWERGRID projects** to ensure compliance with specific contractual requirements. This deployment is authorized only for projects where the **Revised POWERGRID Safety Plan** and **GCC-2025** have been formally incorporated into the contract.
- b) Safety personnel deployment and extensions are subject to actual site requirements and shall require a prior formal approval from the Sector Head/concerned GM by the BHEL Site In-charge.
- c) Total worker strength mentioned in remarks column in above table refers to the overall manpower deployed at site under BHEL, not to the manpower of any individual subcontractor.
- d) Subcontractor shall ensure deployment of safety personnel as per the stipulated qualification and experience on the direction of BHEL site-in-charge.
- e) The subcontractor shall deploy safety personnel within 15 days of formal written intimation by BHEL.
- f) The subcontractor shall submit the credentials and present the candidate to the BHEL Site In-Charge for verification and assessment of suitability prior to deployment.
- g) BHEL shall have the right to accept or reject the candidate upon verification and assessment. Subcontractor shall submit credentials of another suitable candidate within the original stipulated time of 15 days.
- h) BHEL site in-charge may seek help of HSE-HQ in verification and suitability assessment of the candidate.
- i) The deployed safety personnel by subcontractor shall functionally report to BHEL Site In-Charge for daily duties and work assignments.
- j) Subcontractor shall demobilize the safety personnel and terminate the services on the written instruction of BHEL Site in-charge on an advance notice of not less than a month.

	Transmission Business Group Department of Health, Safety & Environment, Noida	Doc No. TBG/HSE/NIT-01 Rev No. : 03 Date: 31.03.26
	NIT HSE Specifications	Page- 9 of 22

- k) The subcontractor shall be solely responsible for fulfilling all legal and contractual obligations without additional cost to BHEL. This includes, but is not limited to: applicable minimum wages, medical services, PPE, leave and overtime compensation, transportation, accommodation, and catering.
- l) Additionally, the subcontractor shall provide all necessary administrative resources, including gate pass processing, seating arrangements, secure record storage, stationery, and continuous access to computing and printing facilities.
- m) The safety personnel may be assigned the responsibilities of one or more agencies other than the employing agency as per requirement.
- n) He shall perform his duties in line to meet the requirements of TBG HSE MANAGEMENT SYSTEMS, such as; but not limited to:
- o Ensure compliance to all legal, regulatory, and contractual HSE obligations including customer's contractual requirements.
 - o Implement and monitor BHEL TBG's HSE Manual, Standard Procedures, Formats, Checklists, and Operational Control Procedures (OCPs) in their true spirit within the agency's work area.
 - o Ensures daily toolbox talks, job safety analyses and timely incident investigations.
 - o Maintain and submit safety records, compliance reports, and participate in HSE meetings and audits.
 - o Coordinate with the BHEL site HSE in-charge and lead in organising HSE campaigns, health check-ups, periodic mock drills and participate in regular HSE performance reviews.
 - o conducting site safety inspections, induction trainings and other HSE training and awareness programs,
 - o Ensure other such compliances as per HSE Plan for Site Operation (TBG/HSEP-14) on regular basis.

The sub-contractor shall ensure that the Safety personnel have adequate authority of decision-making and access to resources including workforce to implement safety measures effectively.
(Rev-03)

c. Safety organisation, Safety committees and meetings

Safety officer shall administratively report to the head of the projects of the sub-contracting agency. There shall be some nominated **safety stewards** from each sub-group like shuttering, bar-bending, concreting, brick work, material handling, structure erection, cable laying, pipe work, maintenance, batching plant, housekeeping, etc.

A **safety committee** shall be formed including members from different agencies, BHEL and customer covering at-least 50% participation from workers. Safety committee shall meet on weekly basis or as may be decided by customer, outcomes shall be complied as committed.

	Transmission Business Group Department of Health, Safety & Environment, Noida	Doc No. TBG/HSE/NIT-01 Rev No. : 03 Date: 31.03.26
	NIT HSE Specifications	Page- 10 of 22

d. Personal Protective Equipment.

Unless mentioned otherwise, there will be three mandatory PPEs- Safety shoes, Safety Helmet and Reflective jackets conforming to relevant IS codes as mentioned above. Every person entering in the project premises shall use above mandatory PPEs.

There will be other PPEs too, based on the work requirement like: Twin lanyard full body harness, fall arresters and life lines for height workers, Face shield for welders and grinders, Induction helmets and Electrical resistant shoes with FRP/PVC toe for electricians and commissioning engineers, Gum boots for concrete workers and manual excavators, Goggle for gas cutters and grinders, Aprons for welders, shoulder pads for material handlers, Hand gloves – Leather for binders/welders/grinders, certified Rubber gloves for electricians, PVC for concrete/cement handlers, cotton-housekeeping team/brick coolies/erectors, cable laying men and other material handlers. Dust mask for cement handlers.

f. Material Handling

BHEL as a policy discourages continuous manual handling. Material handling contributes a major portion in the project and hence proper means (mechanical/ electrical powered) should be deployed appropriately for this work. Cranes/Faranas should not be used for material transportation for long distances(>100m), if such movement is un-avoidable, it must be accompanied by a trained signal man/flag man. Long materials should be guided by tagline. Roads for material movement should be free from obstructions. Lifting appliances must be in good condition and must have test/inspection certificates.

Lifting tackles like- D-shackles, chains, ropes, slings, belts shall be periodically inspected and shall have valid test certificate and/or third-party inspection certificates.

Painted/galvanized structures/materials to be lifted by adequate capacity nylon belts only.

If a machine undergoes a major maintenance, fresh TPI shall be required before use. Hydraulic/pneumatic machines shall be free from leakages. Daily checklist to be filled and witnessed by the concerned supervisor before start of the work.

g. Vehicle/Machinery Documents and other safety requirements (Rev-03)

Sr.:	Required Docs. / compliances	Crawler mounted boom cranes/Tyre mounted telescopic cranes	Loader backhoe (JCB), crawler excavators (Poclairn), Farana lifters/ cranes	Tipper, Transit mixtures/Self-loading concrete mixture (Ajax Fiori), tractors	Cars, Taxis, scooters, motor cycles and other public carriers	Man-lifts (Cherry pickers), Scissors Lifts
1.	Valid third-party inspection certificate.	Yes	Yes	-	-	Yes
2.	Valid Insurance policy	Yes	Yes	Yes	Yes	Yes



NIT HSE Specifications

Sr.:	Required Docs. / compliances	Crawler mounted boom cranes/Tyre mounted telescopic cranes	Loader backhoe (JCB), crawler excavators (Poclain), Farana lifters/ cranes	Tipper, Transit mixtures (TM), Self-loading concrete mixture (Ajax Fiori), Tractors	Cars, Taxis, scooters, motor cycles and other public carriers	Man-lifts (Cherry pickers), Scissors Lifts
3.	Registration Certificate	Yes (if tyre mounted)	Yes	Yes	Yes	Yes (for truck mounted)
4.	Valid Pollution under control (PUC)	Yes (if applicable)	Yes (if applicable)	Yes (if applicable)	Yes (if applicable)	Yes (for truck mounted)
5.	Fitness certificate from RTO	Yes (if tyre mounted)	Yes	Yes	-	Yes (for truck mounted)
6.	Driver/Operator's valid license	Heavy License (LDRXCV/HMV)	Heavy License (LDRXCV/HMV)	Heavy License (HMV)	Yes (As applicable)	Yes (for truck mounted)
7.	Operators experience and/ or competency certificate.	Yes	Yes	-	-	Yes
8.	Swing horn	Yes	-	-	-	Yes
9.	Reverse horn	Yes	Yes	Yes	-	Yes
10.	Boom aviation light	Yes	Yes (if applicable)	-	-	Yes
11.	Approved Load chart (inside cabin)	Yes	Yes (if applicable)	-	-	-
12.	Fire extinguisher (inside cabin)	Yes	Yes	Yes	-	Yes
13.	First aid kit (inside cabin)	Yes	Yes	Yes	Yes	-
14.	Boom angle indicator	Yes	Yes (if applicable)	-	-	Yes (if applicable)
15.	Hook Latch	Yes	Yes (if applicable)	-	-	-
16.	Reflector strips on around cabin and on boom	Yes	Yes	Yes	-	Yes
17.	SLI+Load Limit Switch	Yes	-	-	-	-

	Transmission Business Group Department of Health, Safety & Environment, Noida	Doc No. TBG/HSE/NIT-01 Rev No. : 03 Date: 31.03.26
	NIT HSE Specifications	Page- 12 of 22

Note:

1. No one shall ride man-lift bucket without safety belt, safety shoes, helmet and reflective jacket.
2. Not more than 3 persons at a time will board in bucket of man-lift (without any heavy materials) including operator.
3. Operator will not leave the machine while persons are elevated and working.
4. No one other than the authorised operator will operate the man lifts/Scissors lifts.
5. Hydra cranes are not allowed. Contractors must instead use Farana cranes with that meet safety standards for stability and operator visibility.
6. Farana and other lifting cranes must have operational safe load indicator (SLI) and load limit switch as standard attachment. **(Rev-03)**

h. Excavation

Prior permission/clearance from customer is a must for excavations in areas where underground service services such as gas/water/oil/chemical/electrical lines may be routed. Due precautions shall be taken during excavation in such area. Excavations near water bodies (ponds/canals etc.) shall be done with sand/soil bags ready to plug water from accidental damaged/burst of edges. All the excavations shall be done by either step cutting (min. 600mm step at every 1.5m depth) or slope cutting at 1:2(X:Y axis) (or greater depending upon the soil condition). Where step cutting/slope cutting is not possible due to space constraints, shoring/shuttering or sheet piling to be used to check collapse of soil.

Excavated soil shall be stacked away from edge of the pit, at-least 1.5 meters or half of the depth whichever is higher. Height of the stack shall not exceed 2m in height.

Ramps shall be provided for access of the workers in large pits and ladder of metal/good built for small pits. Ladders shall be of sufficient length protruding at least 1m above the ground level.

Pumps of adequate capacity shall be available for pumping out of water. No lone worker shall be allowed to work in any excavation. Overloaded vehicle shall not be allowed near excavated pits.

i. Bar bending and Binding

Bar bending machine shall be installed under shed/roof. It shall be properly earthed and maintained for operation. Housekeeping of the area shall be team's responsibility on daily basis. All be bar benders shall be given hand gloves (leather/cotton) in addition to mandatory PPEs. Scrap shall be segregated and moved to scrap yard on regular basis. Bar bending station shall be located away from Main plying roads/passages. The station shall be well illuminated, shall have a maintained first aid kit and potable water. Station shall be located in such a way that the movement of the material be minimised.

j. Concreting

No electric vibrators shall be allowed to use. All the concrete workers shall be issued gum boots, safety helmets, reflective jackets and PVC hand gloves. Free fall of concrete from chute shall not exceed 1m in height. Heavy machineries/ vehicles shall be kept at least 2m away from the edge. Emergency vehicle shall be available near concreting work. Late night works shall be avoided, if it is unavoidable, a prior permission from BHEL/Customer is mandatory.

	Transmission Business Group Department of Health, Safety & Environment, Noida	Doc No. TBG/HSE/NIT-01 Rev No. : 03 Date: 31.03.26
	NIT HSE Specifications	Page- 13 of 22

k. Welding, Gas Cutting & other hot works

Welding: Only experienced welders should be deployed for welding jobs. Welders shall be provided with apron, hand gloves, arm pads, leg pads, face shield and safety shoes. Welding leads shall be joint less and insulated. Power input point shall be fully covered at machine.

Gas cutting: If LPG is being used, domestic cylinder is strictly prohibited inside the project premises, (not allowed for site kitchen too). Hose pipes shall be in good condition without cracks, cuts, punctures or joints. Ends should be clamped with worm clamps. Dial gauges shall be of good quality and duly calibrated. Flash back arresters is a must for both oxygen/acetylene or LPG/Oxygen combination. Cylinders shall be stored, transported and used in vertical position only. When not in use, they shall be capped. Empty and filled cylinders to be stored separately with distinct marking.

Cylinders shall neither be rolled on the ground nor thrown during loading/unloading.

Grinding: Grinder shall be given clear glass face shield, apron, safety shoes, ear muffs and hand gloves. Grinder machines shall have wheel guard. Plug tops to be used for power connection preferably three wire type. Only trained persons shall be allowed to use grinders, abrasive cutters. Electrical connection shall be free from cuts, joints etc.

l. Erection & Height Work

Only trained filters and experienced helpers shall be engaged in erection work. Step bolts of lattice towers shall be checked for full tightness with spring washers before use. Height pass shall be issued to the identified group of erectors who have passed medical test and have working experience at height. Name of such workers shall be displayed at appropriate place. These workers only shall be allowed to work at height. Height work shall not be permitted in high wind/bad weather condition, during raining or in night/dark.

m. Electrical Safety

BHEL usually provided single point power source and sub-contractors draw power from there. Otherwise agencies make their own arrangement for construction power like DG sets etc. Sub-contractors shall submit their load requirement (amperage & phase) to BHEL before start of work. Accordingly, they shall make arrangements to draw power and distribution arrangements too in a safe way. MCCBs and HRC fuses to be put in circuit for short circuit and overload protections and RCCBs of 30mA sensitivity to be put at each distribution panel for human safety. Earthing pits shall be installed at each distribution point and maintained below three Ohm resistivity which shall be inspected randomly. The distribution points shall be clean, free from vegetation and water logging, easily accessible and covered/protected from three sides and top for rain. Earthing of DBs shall be done by 25x3mm GI flats connected from proper earth pits. Insulation mat, PVC Sheet/Wooden plank to be placed before DBs as platform. DB Sheds shall be legibly marked with name of agency, contact no of electrician and SLD of that DB. Only industrial plugs and sockets shall be allowed. Three wire (Phase, neutral and earth) system shall be used for tools, lights and machineries and two wire power draws shall be strictly prohibited. PTW and LOTO system shall be maintained to work on LT system. Name and contact no of authorised electricians who will be responsible of electrical power facility maintenance shall be submitted to BHEL by Agencies. Unauthorised sharing of power from one agency to other is strictly prohibited. Electricians shall use standard PPEs and insulated

	Transmission Business Group Department of Health, Safety & Environment, Noida	Doc No. TBG/HSE/NIT-01 Rev No. : 03 Date: 31.03.26
	NIT HSE Specifications	Page- 14 of 22

tools only. Standard and tested/certified discharge rods to be used in the areas where there is a possibility of residual current or induction charge. The induction rod to be connected to the earth first and removed in the last. Induction helmets only to be used in the charged area. Electricians to be provided with electrical resistant safety shoes having FRP/PVC toe.

n. Dust Gases and fumes

Sub-contractor shall make arrangements to avoid accumulation of dust fumes and gases. Cement handlers inside store or at batching plant and gravel spreader shall be given effective nose masks and jaggery (at least 200g per person per day). DG sets and other machineries like cranes excavators etc. shall have valid and effective PUC certificate and shall have maintained engine with silencer. No IC engine operated machine shall be used in confined and covered area like hall, sheds, store etc. where accumulation due to lack of ventilation can increase to harmful levels. Dedicated arrangements (tanker or tractor with sprinkler) shall be made by the sub-contractors (individual or jointly) to continuously subside the dusts arising out of the movement of the vehicle's roads/passages. Welding activities near roof accumulates harmful gases. Welders in such positions shall be provided with effective masks conforming to IS standards.

o. Vehicular Traffic

Speed limits defined within the premises shall strictly be followed by the drivers/commuters of construction as well as other vehicles.

Every construction machinery, man-lift shall display the name, contact no and passport size photograph of the authorised operator (There can be one or more authorised operators).

No one other than operator and co-operator shall sit inside the cabin of any construction machine while it is working.

Construction machineries (tractor, trucks, tippers, JCBs, Farana, Fassi cranes etc. shall never be used as mode of public transport. Machineries like Ajax Fiori and Farana shall not be driven in back direction except for small distances. No overloaded vehicle shall be permitted entry in the project premises.

Over speeding shall be reported and driver/operator shall be barred from entry or shall be penalised.

Drunken drivers shall be barred from entry in the project.

Carrying harmful weapons like knives (>6"), guns etc. shall permanently disqualify the person from entry in project premises.

p. Barricading and floor openings

Every pit deeper than 4 feet (1.2m) shall be barricaded immediately after excavation and will remain barricaded till backfilling.

Pits/trenches drains near roads, passages whether temporary or permanent shall be hard barricaded and well illuminated. Roof edges and openings shall be strictly hard barricaded and illuminated. Height works like masonry works, structure erection, erection by cranes, Lattice tower/beam erection areas shall be barricaded to restrict entry. Areas under charging/commissioning shall be barricaded and caution boards shall be displayed on newly charged areas.

	Transmission Business Group Department of Health, Safety & Environment, Noida	Doc No. TBG/HSE/NIT-01 Rev No. : 03 Date: 31.03.26
	NIT HSE Specifications	Page- 15 of 22

q. Scaffold & Ladder

No bamboo/wooden scaffold shall be allowed to be used. Only tubular steel scaffolds with couplers conforming to the relevant IS codes shall be allowed with base plates. Standard steel or wooden planks to be used as platforms and no packing materials shall be used. All the platforms shall be built with provisions of **top rail at 1m height, mid rail at 0.5m height and toe boards of min 6” height** at floor level. Minimum width of platform shall be 900mm and if wheel barrow is to be used then 1200mm. Means of access to be provided in the form of ladders, ramps or staircase. Multilevel work platforms or those platforms having passage underneath shall be provided with safety net, screen or canopy at each level for protection from falling objects. Platforms shall be free from concrete, debris or other materials. Platforms shall not extend out of the putlogs and shall be secured and fastened. Decking shall be made non-skidding.

Scaffolds under erection shall be tagged “**RED**”, under repair/maintenance/inspection shall be tagged “**YELLOW**” and ready for use shall be tagged “**GREEN**”

Only metal ladders in the construction site and FRP ladders in charged areas shall be allowed. Ladders made from packing materials shall not be used. Ladders shall be securely fixed at bottom, top and long ladders at middle points too at an interval not more than 2400mm and must have a landing at every 6m. Inclination angle should be approximately 1:4 (X:Y) or 75deg. Ladder must extend at least 1m above the platform/access area. Gap between two rungs shall not exceed 300mm. Portable ladder should not be more than 4m in length. Minimum width of the ladder shall not be less than 300mm.

Use of Mobile aluminium scaffold is preferably advisable for erection of transformers/reactors.

r. Illumination

The sub-contractor shall ensure that the areas such as work stations, buildings, batching plants, passages/roads, stores, rest areas, power sources, staircases etc. are illuminated sufficiently to make safe work conditions at site and shall not be less than the relevant IS standards. Excavations/ below ground level structures near passages/roads shall also be sufficiently illuminated.

s. Safety banners/posters, caution boards

Sub-contractors shall display boards and banners in sufficient quantity having safety signs, slogans, important messages, pictures, cautions at prominent locations to promote safety and spread awareness for important precautions such as “Deep Excavation Ahead”, “Speed Limit”, “Charged Area”, “Do not operate”, “Hard hat area”, “No smoking Zone” etc. Boards containing messages of Emergency contacts, First aid facility, rates of minimum wages, working hours, rest day etc. should be displayed at specific areas.

t. Waste management and disposal

Sub-contractor shall make suitable and effective arrangement to remove waste material from site on regular basis and store them in an identified and safe location. Disposal of wastes shall also be done as per manufacturer’s instructions or as per the guidelines laid by legal authorities. Re-bars, Cement bags, packing material (wooden/metal/plastic/paper), paint, oil, grease, cables (armour, sheathing, insulation), civil debris, metal chips, GI sheet scraps, batteries etc. are the common waste materials. Sub-contractor

	Transmission Business Group Department of Health, Safety & Environment, Noida	Doc No. TBG/HSE/NIT-01 Rev No. : 03 Date: 31.03.26
	NIT HSE Specifications	Page- 16 of 22

shall arrange disposal of the hazardous wastes/materials in conformance to the legal and contractual requirements only.

u. Inspection of PPEs, T&Ps, Machineries and lifting appliances

All the PPEs, T&P and lifting appliances purchased newly by sub-contractors shall have test certificates which shall be submitted to BHEL office periodically or on demand. There shall be at least monthly joint inspection schedule for inspection of healthiness of all the PPEs, T&Ps and lifting appliances. All the lifting appliances shall be tested and examined by a competent person before taking into use for the first time or after it has undergone any alterations or repairs liable to affect its strength or stability

and also once at least in every twelve months. To confirm quality of the PPEs as per the relevant IS codes, BHEL may ask sub-contractors to get any or all types of PPEs tested through NABL approved lab as per relevant IS codes. At any stage, the 100% cost of such tests shall be in the scope of respective sub-contractors.

v. Cable Laying

Sub-contractor shall ensure cable trenches free from water, mud, debris, snakes, Scorpions, lizards before start of the work in trenches. Cable drum rollers shall be used to pull cables out of drums to avoid twisting of cables. Hand gloves, Safety shoes/gum boots, reflective jackets, safety helmets shall be provided to the workers. Cable laying area shall be well illuminated.

w. Fire Protection

Every sub-contractor has to maintain their working area, store and office area free from bushes. Stacking of flammable materials like wood, paper, plastic, paint, oil, grease, fuel, cotton, gases etc. at isolated place disconnected from other storage and office areas. Adequate arrangements of firefighting means like suitable extinguishers, fire/water buckets, water tanks, sand dunes etc. shall be made by the agency depending upon the fire capacity assessed or as per MSDS. Fire drills and trainings on how to operate fire extinguishers and how to react in case of fire breakouts shall be the part of regular training program. Guards and store persons must be a regular participant of such training programs. A list of trained firefighting persons and periodicity of such training programs shall be submitted to BHEL by every agency and same to be adhered. Sufficient number of fire extinguishers with suitable class shall be placed at such locations where there can be fire hazard like stores, pantry, office, DG set, electrical distribution panels etc.

x. Fencing of exposed rotating parts

Exposed rotating parts poses great threat to the person in vicinity. Such parts need to be fenced/covered. Guards are mandatory of grinders, abrasive cutters. Flywheels of the engines of heavy machines, Diesel engines, DG sets need to be covered. Electric winch machines, pulleys, chains, shafts, exhaust fans at reachable height, table fans, need to be caged/fenced. Such fencing/guard shall not be removed while machinery is in operation.

	Transmission Business Group Department of Health, Safety & Environment, Noida	Doc No. TBG/HSE/NIT-01 Rev No. : 03 Date: 31.03.26
	NIT HSE Specifications	Page- 17 of 22

y. Emergency preparedness response plan and periodic mock drills.

Sub-contractor shall comply JSA (Job Safety Analysis) and arrange to mitigate the effects of identified possible hazards. He shall also define following in response to emergency preparedness:

An emergency assembly point and put a board of the same with information to all in induction training.

Have facility of ambulance or tie-up with nearest hospital for service in minimum possible time (Max-30min) if there is not ambulance inside the premises.

Ensure availability of emergency vehicle with driver all the time at site during work.

Conduct mock-drills on possible risks like electrocution, fall from height, fire, heat stroke etc., record responses and take photographs to submit in BHEL office. Stretchers availability in emergency vehicle or at work place should be well accessible. Provide fire extinguishers of right type at right place in right quantity with information to all. Display emergency contact nos. to various risk locations and at office, service building or at major work locations. Provide first aid training by doctors for and display names of such trained first aiders and fire fighters. Rescue kit with trained staff or man lift or both to rescue a man hanging by safety belt at height. Provide running water tap near chemical storage and handling points. Agencies shall follow emergency response plan prepared by BHEL in each area of work, store and office.

z. Safety reports & Reporting of accidents

BHEL will provide "formats and checklists" for the purpose of records/documents pertaining to the compliance of aforesaid clauses. Agencies shall be responsible for strict adherence and compliance for timely generation and fill-up of the checklists and reports. These shall be submitted on weekly and monthly basis as specified in the formats.

Agency shall also promote such an environment that the near misses, incidents and accidents are reported by every person, whosoever witnesses them. These shall help in analysing the trend and taking measures in reducing/stopping the accidents/incidents. Initial reporting can be in any form-by call, SMS, WhatsApp, e-mail, letter etc.

Major and fatal accidents or high potential incidents shall be investigated for root cause and outcomes shall be immediately implemented to check recurrences.

7. REPORTING OF ACCIDENTS:

- ❖ Any accident on the construction site which causes loss of life or disables the person from working for a period of more than 10 days, shall be reported in writing to:
 - Regional Labour Commissioner
 - State BOCW Inspector / Board to which the person is registered as beneficiary.
 - Director General of Factory Advice Service and Labour Institutes (DGFASLI), Mumbai
 - Employees' Compensation Commissioner or ESIC Branch Office as applicable
 - Nearest Police Station
 - District Magistrate (in case of fatality)
 - The next of kin or relative of the person.
- ❖ Fatal accidents within 4 hours and major accidents within 72 hours of occurrence must be reported to authorities as above and client. Hiding facts like incidents, accidents, submitting fake/forged reports/certificates shall also attract penalty/ notice or both.

	Transmission Business Group Department of Health, Safety & Environment, Noida	Doc No. TBG/HSE/NIT-01 Rev No. : 03 Date: 31.03.26
	NIT HSE Specifications	Page- 18 of 22

- ❖ All PPEs shall conform to relevant BIS/IEC/EN standards in performance, not merely carry an ISI mark. For helmets, DGMS-approved models should be preferred, 100% compliance is mandatory.
- ❖ Over speeding of vehicles shall attract penalty/notice and recurrence will attract debarring from entry into project premises.
- ❖ Only approved third party agencies shall be allowed to inspect the machines, T&Ps. Reports shall directly be sent to BHEL/customers by the third parties.
- ❖ Insurance and TPIs to be renewed before expiry. Machines, T&Ps shall not be allowed to work if renewal delayed. Continuity of EC policy to be maintained religiously by the respective agencies.
- ❖ Agency shall submit the status report of his labour license, BOCW registration, EC Policy, insurance & TPI certificate's validity on monthly basis with list of machineries and T&Ps
- ❖ Sub-contractors shall also maintain a buffer stock of all the PPEs in at least 20% excess to the present strength of the work force.
- ❖ Agencies shall be responsible for the compliance of the above requirements. Failure in one or more clauses/area shall attract a notice or monetary penalty or a combination of both. **(Rev-03)**

8. PENAL PROVISIONS:

(Rev-03)

- a) Subcontractor shall be responsible for ensuring HSE compliances with respect to the applicable legal and contractual obligations (refer **TBG/HSEP-14** for details). The performance of the subcontractor with respect to HSE compliances shall be evaluated by BHEL on monthly basis (format no. **TBG/HSEP07:F02**).
- b) Non-compliance with any stipulated HSE requirement shall attract a notice and/or a monetary penalty. Such penalties shall be in addition to any medical expenses incurred for treatment of victims or compensation payable to the affected persons or their families, including amounts covered under insurance policies (Employees' Compensation Policy / Group Insurance). Monetary penalties shall be recovered from the next bills or from the EMD/SD of the subcontractors, as applicable.
- c) In addition to the above, BHEL has the right to suspend/debar the subcontractor from participating in future tenders for a period of one year from the date of second fatal accident.
- d) Upon the first incident, BHEL Site In-charge shall issue a notice to the agency, cautioning that suspension/debarment will be considered in the event of a second fatal incident.
- e) Post mobilization, the subcontractor shall consult with the BHEL site in-charge to understand and acknowledge the customer's penal provisions that may be levied upon or passed on to the subcontractor in the event of any non-compliance or incident.

	Transmission Business Group Department of Health, Safety & Environment, Noida	Doc No. TBG/HSE/NIT-01 Rev No. : 03 Date: 31.03.26
	NIT HSE Specifications	Page- 19 of 22

The penalties shall be applicable as below:

8.1. Penal Provisions for Non-Compliances and Safety Violations.

- a) Up to ₹1,000/- per person/incident per day for HSE related non-compliances and safety violations (**Refer- Clause 18**, HSE NON-COMPLIANCE & PENALTIES of TBG/HSEP-14).
- b) Three times consecutive penalty on the same person for the same reason shall debar him/her from working into the TBG project premises.
- c) In case a penalty is imposed by the customer on account of non-compliances and safety violations, the higher of the two amounts shall be recoverable from the subcontractor.

8.2. Penal Provisions for Non-deployment of safety personnel.

- a) Deployment of safety personnel will be done on formal written communication from BHEL. In case the contractor fails to deploy the required safety manpower within the stipulated time, a recovery of **₹50,000/-** per person per month or part thereof shall be made from the next bill, irrespective of the category of safety manpower, notwithstanding availability of schedule of rate item for deployment of safety personnel in the contract which shall be operated as per contract provisions.
- b) Upon failure to deploy the required safety personnel by subcontractor, BHEL reserves the right to deploy a full-time qualified Safety Officer through its existing Safety Consultancy Rate Contract and assign duties of any category of safety personnel. The cost incurred on such deployment shall be recovered from the subcontractor at the higher of the actual expenditure incurred by BHEL or **₹50,000/-** per person per month.
- c) If a safety personnel is deployed by BHEL on behalf of the subcontractor, the person shall remain deployed for a minimum period of two months from the date of deployment and recovery shall be made accordingly. If the subcontractor mobilizes his safety personnel during this period (two months), no payment against that item shall be admissible by BHEL.
- d) Continuous absence of deployed safety personnel for more than **10 days** shall be treated as demobilization, penalty shall be imposed on a pro-rata basis for the entire period of absence.
- e) Any penalty imposed by the customer on account of non-deployment of safety personnel, attributable to sub-contractor shall be recoverable from the subcontractor.
- f) The deployment of safety personnel by BHEL on behalf of subcontractor will not absolve him from legal and contractual obligations.
- g) Instructions of safety person engaged by BHEL directly or indirectly (through other agencies/subcontractors) to be followed by the subcontractor.

	Transmission Business Group Department of Health, Safety & Environment, Noida	Doc No. TBG/HSE/NIT-01 Rev No. : 03 Date: 31.03.26
	NIT HSE Specifications	Page- 20 of 22

- h) BHEL Site In-charge shall issue a written intimation to the subcontractor with copy to TBSM, regarding deployment of safety personnel on behalf of the subcontractor. The subcontractor shall provide a written acknowledgement of the same.

8.3. Penalty Provisions on Major/disablement/Fatal accidents.

- a) Major injuries or accidents causing 25% or more permanent disablement: **₹2,00,000/-** per incident. The cumulative penalty amount shall be limited to 5% of the original contract value.
- b) Fatality or permanent disability with total loss of earning capacity: **₹5,00,000/-** per incident irrespective of contract value.

8.4 If the penalties **imposed by the customer** for major/disablement/fatal accidents, attributable to subcontractor are **higher** than the limits mentioned in **clause 8.3** above, then recoveries shall be made as per the following conditions:

- a) **Contracts up to ₹1 crore value:** Clause no. **8.3** shall apply.
- b) **Contracts above ₹1 crore to ₹5 crore value:** Customer penalty shall be transferred to subcontractor, subject to a liability of the higher of **Rs. 5 lakh** or **3%** of original contract value per person/per incident but not exceeding the actual penalty imposed.
- c) **Contracts with value of more than ₹5 crore:** Customer-imposed penalty shall be transferred to the subcontractor, subject to a liability of the higher of **₹15 lakh** or **2%** of the original contract value per person/per incident, but not exceeding the actual penalty imposed.

9. Creation of common HSE Facilities on contribution basis at sites:

All health, safety and welfare provisions stipulated under the Building and Other Construction Workers (Regulation of Employment and Conditions of Service) Act, 1996 and allied rules shall be adequately and timely complied with by the subcontractor. These include, but are not limited to, arrangements for clean drinking water, toilets and urinals, safe electrical installations, periodic health check-ups of workers, operators and supervisors, medical examination of height workers, tetanus vaccination, induction training and provision of mandatory and job specific PPEs. In the event of non-compliance or delay in fulfilling these obligations, BHEL reserves the right to arrange the same on behalf of the subcontractor, along with applicable overhead charges.

In order to comply with the legal and contractual obligations, BHEL site in-charge shall decide to create certain HSE facilities involving fixed or recurring expenditure which shall

	Transmission Business Group Department of Health, Safety & Environment, Noida	Doc No. TBG/HSE/NIT-01 Rev No. : 03 Date: 31.03.26
	NIT HSE Specifications	Page- 21 of 22

be operated on a contributory basis among the running contracts at site. The contribution shall be determined proportionately based on either the manpower strength or the original contract value of each subcontractor, as decided by the site management. The facilities to be covered under this arrangement include, but are not limited to:

- Dust suppression arrangements,
- Ambulance van (Advanced Life Support type),
- Periodic visit of a qualified medical officer,
- Engagement of trained first-aid person or a qualified nurse for the medical/first-aid centre.
- Drinking water facility with periodic cleaning arrangement.
- Toilet/urinal facility with daily cleaning arrangement.

The contribution per contractor per month shall not exceed ₹20,000 (Rupees Twenty Thousand only). Any balance cost beyond this limit shall be borne by BHEL. **(Rev-03)**

10. Revision History

Revision Date	Revision No.	Old Text	New Text	Reason	Revised by (with sign)
03.05.2019	00	N/A	Full Document	New Release	-sd-
12.10.2021	01	Nil	Attend HSE familiarization program at TBG-HQ with his site management team. This will be a half day long awareness session on HSE requirements and compliances which the agency is supposed to fulfil during contract execution at site. The session shall be taken by TBG HSE department on intimation by TBSM. (at page no. 5)	For better understanding of HSE requirements to agency. (HSE Review meeting dated 23.08.2021)	-sd-
12.10.2021	01	Edition	Inclusion of penalty provisions in case of non-deployment of safety person (page-8)	Introduction of HSEP-14	-sd-
17.01.2024	02	Edition	Appointment and duties of qualified safety officer (Page-8)	As per BOCW 1996	-sd-
05.09.2025	03	Edition	Document name change, Clause (1) new HSE policy, Revised clause 2(a), 3, 6 (b,c,g) addition of new clause 7,8&9,	Inclusion of CFC recommendations	-sd-

-:End of Document:-

BHARAT HEAVY ELECTRICALS LTD.,
TRANSMISSION BUSINESS GROUP, New Delhi
Conditions Of Contract For Civil Works, Doc.No.-TB-Civil-GCC, Rev-02

INDEX

S.No.	Description	Page No.
A.0	GENERAL INSTRUCTIONS TO TENDERERS	04 - 30
A.1.0	Procedure for submission of Tenders	5
A.2.0	Procedure for evaluation of Price Bids	5
A.12.0	Data to be enclosed	7
A.13.0	Earnest Money Deposit	9
A.14.0	Authorization and Attestation	9
A.15.0	Validity of Offer	10
A.16.0	Execution of Contract	10
A.17.0	Security Deposit	10
A.19.0	Rejection of Tender and Other conditions	12
Annex-A	Details of work executed/Being Executed	15
Annex-B	Proposed Manpower	16
Annex-C	Status of Tools, Plants and Instruments	17
Annex-D	Analysis of Unit Rate	18
Annex-E	Declaration sheet	19
Annex-F	Checklist and Schedule of General Particulars	20
Annex-G	Proforma for Contract Agreement	21
Annex-H	Proforma for BG for Security Deposit	23
Annex-I	Proforma for Performance Guarantee	25
Annex-J	Revised offer in lieu of Deviation withdrawal	28
Annex-K	List of Laboratory Test Equipments	29
Annex-L	BG confirmation letter from Banker	30



BHARAT HEAVY ELECTRICALS LTD.,
TRANSMISSION BUSINESS GROUP, New Delhi
Conditions Of Contract For Civil Works, Doc.No.-TB-Civil-GCC, Rev-02

B.0	GENERAL TERMS AND CONDITIONS	31-48
B.1.0	Definitions	32
B.2.0	Law governing the contract and Court Jurisdiction	34
B.3.0	Issue of Notice	34
B.4.0	Use of Land	34
B.5.0	Commencement of Work	35
B.6.0	Measurement of work and Mode of Payment	35
B.7.0	Rights of BHEL	37
B.8.0	Responsibility of Contractor in respect of local laws	38
B.9.0	Responsibility of Contractor in respect of Safety	42
B.10.0	Consequences of Cancellation	45
B.11.0	Insurance	46
B.12.0	Strikes and Lockouts	46
B.13.0	Force Majeure	47
B.14.0	Guarantee	47
B.15.0	Arbitration	47
C.0	SPECIAL CONDITIONS OF CONTRACT	49- 69
C.1.0	Instructions to Tenderers	50
C.2.0	Performance Bond	50
C.3.0	Site Drainage	51
C.4.0	Execution of Work	51
C.5.0	Inspection and Stage approval of work	51
C.6.0	Completion of work	52
C.7.0	Uncovering and Adjustment of Errors	52
C.8.0	Discrepancies and Adjustment of Errors	52
C.9.0	Deviations	54



BHARAT HEAVY ELECTRICALS LTD.,
TRANSMISSION BUSINESS GROUP, New Delhi
Conditions Of Contract For Civil Works, Doc.No.-TB-Civil-GCC, Rev-02

C.10.0	Valuation of Deviations	54
C.11.0	Record and Measurement	55
C.12.0	Contractor's Supervision	56
C.13.0	Labour and Supervision Staff	57
C.14.0	Plant and Equipment at Site	58
C.15.0	Compliance to Regulations and Bye laws	58
C.16.0	Materials obtained from Excavation	58
C.17.0	Treasure, Trove, Fossils etc.	59
C.18.0	Protection and Security	59
C.19.0	Site office and Stores	59
C.20.0	Power and Water	59
C.21.0	Temporary Workshop, Stores, consumables	60
C.22.0	Materials	60
C.23.0	General	62
C.24.0	Delay and Extension of Time	63
C.25.0	Compensation/penalty for Delay	63
C.26.0	Price Variation	63
C.27.0	Over run Charges	65
C.28.0	Octroi and other Duties	65
C.29.0	Terms of Payment	65
C.30.0	Cement and Steel	67
C.31.0	Quality Assurance	68
C.32.0	Clearance of site and Repairs	68
C.33.0	Protection of Work	69
C.34.0	Record of Materials Consumed	69
C.35.0	Secured Advance	69



SECTION- A

GENERAL

INSTRUCTIONS TO

TENDERERS



BHARAT HEAVY ELECTRICALS LTD.,
TRANSMISSION BUSINESS GROUP, New Delhi
Conditions Of Contract For Civil Works, Doc.No.-TB-Civil-GCC, Rev-02

SECTION - A

GENERAL INSTRUCTIONS & INFORMATION FOR TENDERER

A.1.0: PROCEDURE FOR SUBMISSION OF TENDERS

Bidder has to submit offer directly through E-PROCUREMENT MODE. Bidder may visit <https://eprocurebhel.co.in>

Procedure for Submission of Tenders through e tendering : The tender is also floated online through our E-Procurement Site <https://eprocurebhel.co.in> . The bidder may respond by submitting their offer online in our e-Procurement platform at <https://eprocurebhel.co.in>

Offers are invited in two-parts only.

Documents Comprising the e-Tender

The tender shall be submitted online EXCEPT EMD (which shall be submitted in physical form (as described in NIT cl. No.1) above as mentioned below:

a. Technical Bid (Un priced Tender)

All Technical details (eg. Eligibility Criteria requested (as mentioned below)) should be attached in e-tendering module, failing which the tender stands invalid & may be REJECTED. Bidders shall furnish the following information along with technical tender (preferably in pdf format):

- i. Earnest money Deposit (EMD) furnished in accordance with NIT Clause 4.0
- ii. Technical Bid (without indicating any prices).

b. Price Bid:

- i. Prices are to be quoted in the **attached Price Bid format online on e-tender portal**.
- ii. The price should be quoted for the accounting unit indicated in the e-tender document.
- iii. Note: It is the responsibility of tenderer to go through the Tender document to ensure furnishing all required documents in addition to above, if any. Any deviation would result in REJECTION of tender and would not be considered at a later stage at any cost by BHEL.
- iv. A person signing (manually or digitally) the tender form or any documents forming part of the contract on behalf of another shall be deemed to warrantee that he has authority to bind such other persons and if, on enquiry, it appears that the persons so signing had no authority to do so, the purchaser may, without prejudice to other civil and criminal remedies, cancel the contract and hold the signatory liable for all cost and damages.
- v. A tender, which does not fulfil any of the above requirements and/or gives evasive information/reply against any such requirement, shall be liable to be ignored and rejected.

c. Uploading of the price bid in prequalification bid or technical bid may **RESULT IN REJECTION** of the tender.

d. Tenders shall be uploaded with all relevant PDF/zip format. The relevant tender documents should be uploaded by an authorized person having Class 3- SHA2- 2048 BIT- SIGNING & ENCRYPTION digital signature certificate (DSC).

A.2.0: PROCEDURE FOR EVALUATION OF PRICE BIDS:

The following shall be Evaluation *Procedure* of the prices offered: -

Payment terms, Completion Schedule and other contractual terms & conditions shall be as per Tender Specifications.

No deviations are acceptable. Offers with deviations are likely to be rejected.



BHARAT HEAVY ELECTRICALS LTD.,
TRANSMISSION BUSINESS GROUP, New Delhi
Conditions Of Contract For Civil Works, Doc.No.-TB-Civil-GCC, Rev-02

However, if the bidder insists on any technical or commercial deviations from the specifications and / or tender conditions, **the price implication, if any, of withdrawing the deviations must be submitted along with the price bid in a separate sealed envelope** super-scribed "Price implication for withdrawal of deviations". No price implication for withdrawal of deviation shall be accepted at a later date, after opening of technical bid.

The offers of new vendors may not be considered even after opening of price bid if the vendor is not found suitable on final assessment.

- A.3.0 This tender specification as a whole, furnishing all the details and other documents as required in the following pages, shall be duly signed & sent in a sealed cover superscribing the name of work as given in the tender enquiry.
- A.4.0 The tender shall be addressed to: OFFICER INVITING THE TENDER AS INDICATED IN THE TENDER ENQUIRY.
- A.5.0 DELETED
- A.6.0 Tenders shall be opened by the concerned officers of BHEL at the time, date and venue as specified in the tender notice.
- A.7.0 The tenderer shall closely pursue all the clauses, specifications and drawings indicated in the Tender Documents before quoting. Should the tenderer have any doubt about the meaning of any portion of the Tender Specifications or find discrepancies/omission in the drawings or the tender documents issued are incomplete or shall require clarification on any of the technical aspect, scope of work etc. he shall at once contact the authority inviting the tender for clarification before the submission of the tender.
- A.8.0 Before tendering, the tenderer are advised to inspect the site of work & the environments and be acquainted with the actual working and other prevalent conditions, facilities available, position of material and labour. No claim will be entertained later on the grounds of lack of knowledge.



BHARAT HEAVY ELECTRICALS LTD.,
TRANSMISSION BUSINESS GROUP, New Delhi
Conditions Of Contract For Civil Works, Doc.No.-TB-Civil-GCC, Rev-02

- A.9.0 Tenderer must fill up all the schedules and furnish all the required information as per the instructions given in various sections of the tender specification. Each and every page of the Tender Specification must be SIGNED AND SUBMITTED ALONG WITH THE OFFER by the Tenderer in token of complete acceptance thereof. The information furnished shall be complete by itself.
- A.10.0 The tenderer shall quote the rates in English Language and international numerals. Total price offered should be entered in figures as well as in words. In case of difference in price between words & figures, the price in words will be treated as valid price. For the purpose of the tender, the metric system of units shall be used.
- A.11.0 All entries in the tender shall either be typed or be written in ink. Erasers and overwriting are not permitted and may render such tender liable to summary rejection. All cancellations and insertions shall be duly attested by the tenderer.
- A.12.0 **DATA TO BE ENCLOSED:**
- A.12.1 An attested copy of the Power of Attorney, in case the tender is signed by an individual other than the sole proprietor, shall be attached.
- A.12.2 IN CASE OF INDIVIDUAL: His full name, experience, address and nature of business.
- OR
- IN CASE OF PARTNERSHIP FIRMS: The names of all the partners with address and their experience. A copy of the partnership deed/instrument of partnership duly certified by the Notary shall be enclosed.
- OR
- IN CASE OF COMPANIES: Date & place of registration including date of commencement certificate in case of Public Companies and the nature of business carried on by the company. Certified copies of Memorandum and Articles of Association are also to be furnished. Also indicate names, addresses and experience of the Directors.
- A.12.3 Three years financial turn over (certified), present commitments with all orders in hand, value of total order, value completed, and balance with completion dates as per ANNEXURE-A.



BHARAT HEAVY ELECTRICALS LTD.,
TRANSMISSION BUSINESS GROUP, New Delhi
Conditions Of Contract For Civil Works, Doc.No.-TB-Civil-GCC, Rev-02

A.12.4 ORGANIZATION CHART & METHODS STATEMENT:

The organization pattern and the manpower that are totally available with him & that will be deployed by the tenderer for this work in the form of month wise and category wise deployment plan duly indicating the number of Engineers, Supervisors, Skilled and Unskilled Workers etc. as per proforma at ANNEXURE-B shall be submitted. Work schedule (detail bar chart) and a methods statement showing how the contractor proposes to mobilise (considering the difficulties in work that may be encountered) and complete the jobs giving an idea of extent of proposed mechanisation for the execution of the jobs shall also be submitted along with ANNEXURE-B.

A.12.5 A list of machines, tools and tackles that the tenderer is having and those that will be deployed on this job giving proof of ownership or any tie-up of equipment as per proforma enclosed at ANNEXURE-C.

A.12.6 Analysis of unit rate quoted as per proforma enclosed at ANNEXURE-D.

A.12.7 Declaration sheet as per proforma enclosed at ANNEXURE-E.

A.12.8 Check-list as per proforma enclosed at (ANNEXURE-F).

A.12.9 Certificate from Schedule Bank to prove his financial capacity to undertake the work or Solvency Certificate from the concerned Government Authority.

A.12.10 A certificate of Income Tax / Sales Tax verification from the appropriate authority in the forms prescribed duly indicating annual turnover. These certificates shall be valid for one year from the date of issue or for the period prescribed therein for all tenders submitted during the period.

A.12.11 In addition to the above, the particulars required elsewhere in the tender documents.

A.12.12 NOTE: In terms of clauses A.12.1 to A.12.11 above, all the data required to be enclosed with the tender need to be furnished neatly typed, signed & stamped in the given formats only (in the form of separate sheets) failing which the tender may be considered as incomplete and is liable for rejection. Documentary proof wherever necessary also need to be enclosed.



BHARAT HEAVY ELECTRICALS LTD.,
TRANSMISSION BUSINESS GROUP, New Delhi
Conditions Of Contract For Civil Works, Doc.No.-TB-Civil-GCC, Rev-02

A.13.0 EARNEST MONEY DEPOSIT: For EMD Clause Please refer Annexure to GCC for Civil work

Every tender must be accompanied by the prescribed amount of Earnest Money Deposit (EMD) mentioned in NIT

1. Mode of EMD deposit:

EMD can be submitted in any one of the following modes:

- i) Cash deposit as permissible under the extant Income Tax Act (before tender opening),
- ii) Electronic Fund Transfer credited in BHEL account (before tender opening). Details of BHEL account mentioned in tender document.
- iii) Banker's cheque/Pay order/Demand Draft, in favour of 'BHEL' and payable at New Delhi (Along with offer)
- iv) Fixed Deposit Receipt (FDR) issued by schedule Banks/Public Finance Institutions as defined in the companies ACT (FDR should be in the name of the contractor, a/c BHEL
- v) In case total EMD amount is more than Rs. 2 Lakh, the amount in excess of Rs. 2 lakh may be accepted in the form of Bank Guarantee from scheduled bank. The Bank Guarantee in such cases shall be valid for at least six months.

No other form of EMD remittance shall be acceptable to BHEL.

2. Forfeiture of EMD

EMD by the bidder will be forfeited as per NIT conditions, if

- i) After opening the tender and within the offer validity period, the bidder revokes his tender or makes any modification in his tender which is not acceptable to BHEL.
- ii) The contractor fails to deposit the required Security deposit or commence the work within the period as per LOI/contract.

3. EMD by the tenderer shall be withheld in case any action on the tenderer is envisaged under the provision of extant "Guidelines on Suspension of business dealing with supplier/contractors" and forfeited/ released based on the action as determined under these guidelines.

4. In the case of unsuccessful bidders, the Earnest Money will be refunded to them within a reasonable time after award of work.

5. EMD shall not carry any interest.

6. EMD of successful bidder shall be retained as part of Security Deposit.

7. Bidders may please note that "One Time EMD" provision stands deleted. Hence, bidders who have deposited Rs. 2 Lakh as 'One Time EMD' with BHEL are also required to submit the requisite amount of EMD.

8. No MSE benefits shall be given to MSEs bidder for WORKS CONTRACT. Please refer clause no. P (facilities provided to MSEs) for detail.

A.14.0 AUTHORIZATION AND ATTESTATION:

Tenders shall be signed by persons duly authorized/empowered to do so. Certified copies of such authority & relevant documents shall be submitted along with the tenders.



BHARAT HEAVY ELECTRICALS LTD.,
TRANSMISSION BUSINESS GROUP, New Delhi
Conditions Of Contract For Civil Works, Doc.No.-TB-Civil-GCC, Rev-02

A.15.0 VALIDITY OF OFFER:

THE OFFER SHALL BE KEPT OPEN FOR ACCEPTANCE FOR A MINIMUM PERIOD OF **FOUR MONTHS** FROM THE DATE OF OPENING OF TENDERS. In case BHEL calls for negotiations, such negotiations shall not amount to cancellation or withdrawal of the original offer which shall be binding on the tenderer.

A.16.0 EXECUTION OF CONTRACT:

The successful tenderer's responsibility under this contract commences from the date of issue of the Letter of Intent by BHEL. The successful tenderer shall be required to execute an agreement in the prescribed form as per ANNEXURE-G with BHEL within a reasonable time after the acceptance of his tender and in any case before submitting the first bill for payment. The expenses for completion, stamping and registration of the agreement with prescribed authority if necessary, shall be borne by the contractor.

A.17.0 SECURITY DEPOSIT: **For Security Deposit clause Please refer Annexure to GCC for Civil work**

Security Deposit means the security provided by the Contractor towards fulfilment of any obligations in terms of the provision of the contract.

1. Upon acceptance of Tender, the successful Tenderer should deposit the required amount of Security Deposit for satisfactory completion of work. **The total amount of Security Deposit will be 5% of the Contract Value. EMD of the successful tenderer shall be converted and adjusted towards the required amount of Security Deposit.**

2. Mode of Security deposit:

The security Deposit should be furnished **before start of the work** by the contractor.

“Bidders agrees to submit performance security required for execution of the contract within the time period mentioned. In case of delay in submission of Performance security, enhanced performance security which would include interest (SBI rate + 6%) for the delayed period, shall be submitted by the bidder. Further, if performance security is not submitted till such time the first bill becomes due, the amount of performance security due shall be recovered as per terms defined in NIT / Contract, from the bills along with due interest”.

The balance amount to make up the required Security Deposit of 5% of the contract Value may be furnished in any of the following forms:

- i) Cash (as permissible under the extant Income Tax Act)
- ii) Local cheques of scheduled banks (subject to realization) / Pay Order / Demand Draft / Electronic Fund Transfer, in favour of BHEL.
- iii) Bank Guarantee from Scheduled Banks / Public Financial Institutions as defined in the Companies Act. The Bank Guarantee format for Security Deposit is enclosed.
- iv) Fixed Deposit Receipt issued by Scheduled Banks / Public Financial Institutions as defined in the Companies Act. The FDR should be in the name of the contractor, A/C BHEL and duly discharged on the back.
- v) Securities available from Indian Post Offices such as National Savings Certificates, Kisan Vikas Patras etc. (Certificates should be held in the name of Contractor furnishing the security and duly endorsed/hypothecated/pledged, as applicable, in favour of BHEL and duly discharged on the back).

(NOTE: BHEL will not be liable or responsible in any manner for the collection of interest or renewal of the documents or in any other matter connected therewith)



**BHARAT HEAVY ELECTRICALS LTD.,
TRANSMISSION BUSINESS GROUP, New Delhi**

Conditions Of Contract For Civil Works. Doc.No.-TB-Civil-GCC. Rev-02

3. Submission of Security Deposit:

i) At least 50 % of the required Security Deposit, including the EMD, shall be submitted before start of work. Balance of the Security Deposit can be submitted by way of deduction of 10% of the gross amount progressively from each running bills of the contractor till the total amount of the required Security Deposit is collected.

ii) If the value of work done at any time exceeds the contract value, the amount of Security Deposit shall be correspondingly enhanced and the additional Security Deposit shall be immediately deposited by the Contractor or it shall be recovered from payment/s due to the Contractor.

iii) The recoveries made from running bills (cash deduction towards balance SD amount) can be released against submission of equivalent Bank Guarantee in acceptable form, but only once, before completion of work, at the discretion of BHEL.

4. The BG shall be submitted only through the Banker. Along with the BG, the Bank shall also furnish a letter of confirmation (in the prescribed formats enclosed with general conditions of contract).

5. The validity of the Bank Guarantee furnished towards Security Deposit shall be up to three months more than the period of completion of work as stipulated in the LOI and the same will be kept valid by proper renewal till the completion of the work.

6. BHEL reserves the right of forfeiture of Security Deposit in addition to other claims and penalties in the event of the contractor's failure to fulfil any of the contractual obligations or in the event of termination of contract as per terms and conditions of the contract. BHEL reserves the right to set off the Security Deposit, against any claims of any other contracts with BHEL.

7. Conditions for acceptance of bank guarantees

Contractors are advised to obtain Bank Guarantee preferably from any of the following BHEL consortium banks

Sl. No.	Nationalized Bank	Sl. No.	Public Sector Banks
1	Allahabad bank	20	IDBI
2	Andhra bank		
3	Bank of Baroda		Foreign bank
4	Canara Bank		
5	Corporation bank	21	CITI Bank N.A
6	Central bank of India	22	Deutsche Bank AG
7	Indian Bank	23	The Hongkong and Shanghai Banking Corporation Limited
8	Indian Overseas Bank	24	Standard Chartered Bank
9	Oriental bank of Commerce	25	J P Morgan
10	Punjab National Bank		
11	Punjab & Sindh Bank		Private bank
12	State Bank of India	26	Axis Bank
13	State Bank of Hyderabad	27	The Federal Bank Limited
14	Syndicate Bank		
15	State Bank of Travancore	29	Kotak Mahindra Bank
16	UCO Bank	30	ICICI
17	Union Bank of India	31	Indusind Bank
18	United Bank of India	32	Yes Bank
19	Vijaya Bank		



BHARAT HEAVY ELECTRICALS LTD.,
TRANSMISSION BUSINESS GROUP, New Delhi
Conditions Of Contract For Civil Works, Doc.No.-TB-Civil-GCC, Rev-02

Bank Guarantees from Banks outside BHEL's consortium shall be as below:

The Bank Guarantees of all Public sector banks can be accepted (in addition to consortium banks)

The Bank Guarantees of Co-operative banks shall not be accepted.

Bank Guarantees of other than consortium bank and public sector bank can be accepted subject to an overall exposure limit (at New Delhi) of Rs. 10 crores for banks with networth of more than Rs. 500 crores as on last balance sheet date and Rs 5 crores for banks with net worth between Rs. 350 to Rs 500 crores (A certificate and copy of latest Balance Sheet to be given by the Bank at the time of submission of Bank Guarantees).

In case of private sector banks a clause to be incorporated in the text of Bank Guarantee that it can be enforceable by being presented at any branch of the bank.

In case of foreign vendors the bank guarantees issued by foreign banks may be confirmed by our consortium bank in India.

In case of Bank Guarantees given by Non-Consortium banks (Private sector or Public sector), the Bank Guarantees are to be enforceable in New Delhi or the town/ city in which the sector office is located.

1. RETURN OF SECURITY DEPOSIT:

If the contractor duly performs and completes the work in all respects to the entire satisfaction of BHEL and presents an absolute "No demand certificate", returns properties belonging to BHEL, taken, borrowed or hired by him for carrying out the said works, and furnishes performance bond BG in the prescribed proforma as per ANNEXURE-J, Security Deposit will be released to the contractor after deducting all costs, expenses and other amounts that are to be paid to BHEL under this contract or other contracts entered into with the contractor. It may be noted that in no case the Security Deposit shall be refunded/released prior to passing of final bill.

A.18.0 No interest shall be payable by BHEL on EMD, Security Deposit or on any money due to the contractor.

A.19.0 REJECTION OF TENDER & OTHER CONDITIONS:

A.19.1 The decision of acceptance of tender will rest with BHEL which does not bind itself to accept the lowest tender or any tender and reserves to itself full rights for the following without assigning any reasons whatsoever:

- (a) To reject any or all of the tenders.
- (b) To split up the work amongst two or more Tenderer.
- (c) To award the work in part.
- (d) In either of the contingencies stated in (b) and (c) above to modify the time for completion suitably.



BHARAT HEAVY ELECTRICALS LTD.,
TRANSMISSION BUSINESS GROUP, New Delhi
Conditions Of Contract For Civil Works, Doc.No.-TB-Civil-GCC, Rev-02

- A.19.2 Conditional and unwitnessed tenders, tenders containing absurd or unworkable rates & amounts, tenders which are incomplete or otherwise considered defective and tenders not in accordance with the tender conditions, specifications etc. are liable to be rejected.
- A.19.3 In case of any adverse information is received concerning performance, capability or conduct of the tenderer after issue of tender enquiry, BHEL reserves the right to reject the offer at any stage as deemed fit.
- A.19.4 Offers with inadequate Tools & Plants, Manpower Deployment Plan, Method Statement are liable for rejection.
- A.19.5 In case the present commitments of the tenderer is such that award of further work is likely to affect performance in the work under this tender, its offer is liable for rejection.
- A.19.6 Offers from tenderer are liable for rejection if the tenderer is not found suitable after preliminary/ final assessment by BHEL.
- A.19.7 If a tenderer expires after the submission of his tender or after the acceptance of his tender, BHEL may at its discretion, cancel such tender. If a partner of a firm expires after the submission of the tender or after the acceptance of the tender, BHEL may cancel such tender at its discretion unless the firm retains its character.
- A.19.8 BHEL will not be bound by any Power of Attorney granted by the tenderer or by changes in the composition of the firm made subsequent to the execution of the contract. BHEL may, however, recognise such Power of Attorney and changes after obtaining proper legal advice, the cost of which will be chargeable to the contractor concerned.
- A.19.9 If the tenderer deliberately gives wrong information in his tender, BHEL reserves the right to reject such tender at any stage or to cancel the contract, if awarded, and forfeit the Earnest Money/Security Deposit/any other moneys due.
- A.19.10 Canvassing in any form in connection with the tender is strictly prohibited and the tenders submitted by the contractors who resorts to canvassing are liable to be rejected.



BHARAT HEAVY ELECTRICALS LTD.,
TRANSMISSION BUSINESS GROUP, New Delhi
Conditions Of Contract For Civil Works, Doc.No.-TB-Civil-GCC, Rev-02

- A.19.11 Should a tenderer or contractor or in the case of a firm or company of contractors/ one or more of its Partners/ Share holders/ Directors have a relation or relations employed in BHEL, the authority inviting tender shall be informed to the fact along with the offer, failing this, BHEL may, at its sole discretion reject the tender or cancel the contract and forfeit the Earnest Money/ Security Deposit.
- A.19.12 The successful tenderer should not sub-contract the part or complete work detailed in the tender specifications without written permission of BHEL. The tenderer is solely responsible to BHEL for the work awarded to him.
- A.19.13 NO DEVIATIONS ARE ACCEPTABLE. OFFERS WITH DEVIATIONS ARE LIKELY TO BE REJECTED. HOWEVER, IF THE BIDDER INSISTS ON ANY TECHNICAL OR COMMERCIAL DEVIATIONS FROM THE SPECIFICATIONS AND / OR TENDER CONDITIONS, **THE PRICE IMPLICATION, IF ANY, OF WITHDRAWING THE DEVIATIONS MUST BE SUBMITTED ALONG WITH THE PRICE BID IN A SEPARATE SEALED ENVELOPE SUPER-SCRIBED “PRICE IMPLICATION FOR WITHDRAWAL OF DEVIATIONS”.** NO PRICE IMPLICATION FOR WITHDRAWAL OF DEVIATION SHALL BE ACCEPTED AT A LATER DATE, AFTER OPENING OF TECHNICAL BID.



BHARAT HEAVY ELECTRICALS LTD.,
TRANSMISSION BUSINESS GROUP, New Delhi
Conditions Of Contract For Civil Works, Doc.No.-TB-Civil-GCC, Rev-02

ANNEXURE - A

DETAILS OF WORK EXECUTED/BEING EXECUTED

A) WORK EXECUTED

Sl. No.	Financial Year	Customer	Description of work	Total order value	Remarks

B) WORK BEING EXECUTED

Sl. No.	Customer	Description of work	Total Value	Value of the portion completed	Actual start date	Expected completion date	Remarks

(SIGNATURE OF TENDERER)
WITH STAMP



BHARAT HEAVY ELECTRICALS LTD.,
TRANSMISSION BUSINESS GROUP, New Delhi
Conditions Of Contract For Civil Works, Doc.No.-TB-Civil-GCC, Rev-02

ANNEXURE - B

(A) **PROPOSED MANPOWER (ENGINEERS/ SUPERVISORS) RESOURCES FOR EXECUTION OF WORK**

Sl. No.	Name of the staff	Qualification	Experience in years	Remarks

(B) **MONTH WISE MANPOWER DEPLOYMENT PLAN**

Sl. No.	Category	Indicate No. of persons to be deployed in each month								
		1st	2nd	3rd	4th	5th	6th	7 th	8 th	and so on

(C) **Total man days planned to be deployed for the work Man days**

(SIGNATURE OF TENDERER)
 WITH STAMP



BHARAT HEAVY ELECTRICALS LTD.,
TRANSMISSION BUSINESS GROUP, New Delhi
Conditions Of Contract For Civil Works, Doc.No.-TB-Civil-GCC, Rev-02

ANNEXURE - C

(A) STATUS OF TOOLS, PLANTS & INSTRUMENTS

Sl. No.	Name of Equipment	Quantity owned	Registration No.	Documents enclosed for proof of Ownership / tie-up	Present Location	Quantity proposed to be deployed for this job

B) MONTH WISE TOOLS, PLANTS & INSTRUMENTS DEPLOYMENT PLAN

Sl. No.	Description of Tools, Plants & Instruments	Indicate Nos. to be deployed in each month							
		1 st	2 nd	3 rd	4 th	5 th	6 th	7 th	and so on

(SIGNATURE OF TENDERER)
WITH STAMP



BHARAT HEAVY ELECTRICALS LTD.,
TRANSMISSION BUSINESS GROUP, New Delhi
Conditions Of Contract For Civil Works, Doc.No.-TB-Civil-GCC, Rev-02

ANNEXURE - D

ANALYSIS OF UNIT RATE

Sl. No.	Description	Percentage of the unit rate	Remarks
01.	Salary and wages for staff and works		
02.	Materials a) b) c) d)		
03.	Depreciation and maintenance for Tools and Plants		
04.	Depreciation and maintenance for other items		
05.	Establishment and administrative expenses of site		
06.	Overheads		
07.	Profit		

(SIGNATURE OF TENDERER)
WITH STAMP



ANNEXURE - E

DECLARATION SHEET

I hereby certify that all the information and data furnished by me with regard to this Tender Specification No..... are true and complete to the best of my knowledge. I have gone through the specification, conditions and stipulations in detail and agree to comply with the requirements and intent of specifications.

I further certify that I am the duly authorised representative of the under mentioned tenderer and a valid power of attorney to this effect is also enclosed.

TENDERER'S NAME AND ADDRESS

AUTHORISED REPRESENTATIVE'S SIGNATURE WITH NAME AND ADDRESS



BHARAT HEAVY ELECTRICALS LTD.,
TRANSMISSION BUSINESS GROUP, New Delhi
Conditions Of Contract For Civil Works, Doc.No.-TB-Civil-GCC, Rev-02

ANNEXURE - F

CHECKLIST & SCHEDULE OF GENERAL PARTICULARS

NOTE: Tenderers are requested to fill in the following details and no column should be left blank.

- | | | | |
|-----|--|---|---------|
| 1. | Name & Address of the Tenderer | : | |
| 2. | Phone/Fax No. (Office) | : | |
| 3. | email ID | : | |
| 4. | Name & designation of the official of the tenderer to whom all the references shall be made | : | |
| 5. | Tenderer's Proposal No. & date | : | |
| 6. | Whether EMD submitted (by cash/ Bank Guarantee/Bank Draft) | : | By..... |
| 7. | Validity of offer/rates quoted for six months from the date of opening of tender | : | Yes/No |
| 8. | Attested copy of power of attorney as per Clause-A.12.1 | : | Yes/No |
| 9. | Solvency Certificate submitted as per Clause-A.12.9 | : | Yes/No |
| 10. | Income Tax/Sales Tax Certificate submitted as per Clause-A.12.10 | : | Yes/No |
| 11. | Details of work executed/being executed as per Annexure-A | : | Yes/No |
| 12. | Month wise & Category wise manpower deployment plan as per Annexure-B | : | Yes/No |
| 13. | Status of Tools, Plants and Instruments & their month wise deployment plan as per Annexure-C | : | Yes/No |
| 14. | Analysis of unit rate quoted as per Annexure-D | : | Yes/No |
| 15. | Declaration sheet as per Annexure-E | : | Yes/No |
| 16. | Request for registration (for new tenderers) submitted | : | Yes/No |

Date

(SIGNATURE OF TENDERER)
WITH STAMP

WITNESS : (Signature with full particulars)

1.

2.



ANNEXURE - G

PROFORMA FOR CONTRACT AGREEMENT

CONTRACT NO. :
LETTER OF INTENT NO. :
WORK ORDER NO. :

1. The Contract Agreement entered into the day of, 20... (..... day oftwo thousand and.....) at New Delhi, between M/S BHARAT HEAVY ELECTRICALS LIMITED, TRANSMISSION BUSINESS GROUP, New Delhi , having its Registered Office at BHEL House, Siri Fort, New Delhi - 110 049 (hereinafter called the FIRST PARTY which expression shall include their executors, administrators, successors and permitted assigns)

AND

M/S (hereinafter called the SECOND PARTY which expression shall include their executors, administrators, successors and permitted assigns).

2. And whereas the FIRST PARTY called for the offer for the work of..... as per approved specifications, drawings and quality plan at as per Tender Specification No..... , dated
3. Whereas the SECOND PARTY submitted their offer No. dated against above.
4. Whereas the FIRST PARTY has accepted the offer referred to above & issued Letter of Intent No....., dt..... and also detailed Work Order No...., dt
5. Whereas the SECOND PARTY has agreed to work as Sub-Contractor of the FIRST PARTY on the conditions specified in the Tender Specifications at a contract price of Rs..... (Rupees.....) at
6. Now, therefore it is hereby mutually agreed to by and between the parties hereto as under :
- a) The SECOND PARTY shall execute the works of at on the conditions specified in Tender Specifications of FIRST PARTY and Letter of Intent referred to herein before at a total contract price of Rs..... (Rupees)
- b) That the SECOND PARTY shall organise all activities and mobilisation of facilities so that the work specified herein before is completed byas per the time bound programme mentioned in the Tender Specifications.



BHARAT HEAVY ELECTRICALS LTD.,
TRANSMISSION BUSINESS GROUP, New Delhi
Conditions Of Contract For Civil Works, Doc.No.-TB-Civil-GCC, Rev-02

- c) That all disputes arising out of or relating to this agreement shall be referred to the sole Arbitrator as per arbitration clause mentioned in the Tender Specifications. The Arbitrator from time to time with the consent of the parties enlarge the time for making and publishing award without reference to the court for the purpose.
- d) That the jurisdiction in all suits or claims arising out of this agreement shall be of New Delhi Courts only.
- e) The Following documents shall form part of this agreement: -
- i)
 - ii)
 - iii)
 - iv)
 - v)
 - vi)
7. Deviation Limit : The contract value is subject to deviations depending upon the actual requirement within plus or minus 30%. Quantities of individual items may vary to any extent or may get deleted.
8. Terms of Payment : The terms of payment applicable to this contract shall be those covered under Point No.... of Work Order dt. and as per Tender Specifications.
9. Abandoning the work : In the event of the SECOND PARTY abandoning the work, FIRST PARTY reserves the right to get the unfinished work done at the risk and cost of the SECOND PARTY.
10. All other terms and conditions shall be as stipulated in the Tender Documents.
11. This contract agreement consists.... pages.

IT WITNESS WHEREOF, the parties have signed this agreement on the date, month and year first above written in presence of

For and on Behalf of
(FIRST PARTY)

WITNESS (WITH ADDRESS)

For and on Behalf of
(SECOND PARTY)

- 1.
- 2.



ANNEXURE - H

PROFORMA FOR BANK GUARANTEE (FOR SECURITY DEPOSIT)

1. In consideration of the Bharat Heavy Electricals Limited, having its Registered Office at BHEL House, Siri Fort, New Delhi-110 049 through its Unit/Division at Industry Sector-TBG, New Delhi hereinafter called BHEL, having agreed to exempt..... (hereinafter called "the said contractor(s)") from the demand, under the terms and conditions of the LOI/WO, dated ... made between BHEL and M/s..... for the work of (Name of work) (hereinafter called "the said Agreement") of Security Deposit / mobilisation advance for the due fulfilment by the said contractor(s) of the terms and conditions contained in the said Agreement, on production of Bank Guarantee for Rs.... (Rupees..... only). We, (indicate the name of the Bank) (hereinafter referred to as "Bank") at the request of the contractor(s) do hereby undertake to pay to BHEL an amount not exceeding Rs..... against any loss or damage caused to or suffered or would be caused to or suffered by BHEL, by reason of a breach by the said contractor(s), of any of the terms of conditions contained in the said agreement.
2. We, (indicate the name of the Bank) do hereby undertake to pay the amounts due and payable under this guarantee without any demur, merely on a demand from BHEL, stating that the amount claimed is due by way of loss or damage caused to or would be caused to or suffered by BHEL by reason of breach by the said contractor(s) of any of the terms or condition(s) failure to perform the said agreement or by reason of the contractor(s) failure to perform the said agreement. Any such demand made on the Bank shall be conclusive as regards the amount due and payable by Bank under this guarantee. However, our liability under this guarantee shall be restricted to an amount not exceeding Rs.....
3. We, (Indicate the name of the Bank) undertake to pay BHEL any money so demanded not withstanding any dispute or disputes raised by the Contractor(s) in any suit or proceeding pending before any court or Tribunal relating there to, our liability under these presents being absolute and unequivocal. The payment so made by us under this bond shall be a valid discharge of our liability for payment there under and the contractor(s) shall have no claim against us for making such payment.
4. We, ...(indicate the name of the Bank) further agree that the guarantee herein after contained shall remain in full force and effect during the period that would be taken for the performance of the said agreement & that it shall continue to be enforceable till all the dues of BHEL under or by virtue of the



BHARAT HEAVY ELECTRICALS LTD.,
TRANSMISSION BUSINESS GROUP, New Delhi
Conditions Of Contract For Civil Works, Doc.No.-TB-Civil-GCC, Rev-02

said agreement have been fully paid and its claims satisfied or discharged or till BHEL certifies that the terms and conditions of the said agreement have been fully and properly carried out by the said contractor(s) & accordingly discharges this guarantee. Unless a demand or claim under this guarantee is made on us in writing on or before..... we shall be discharged from all liability under this guarantee thereafter.

5. We,.....(indicate the name of the Bank) further agree with BHEL that BHEL shall have the fullest liberty without our consent & without affecting in any manner our obligations hereunder to vary any of the terms & conditions of the said agreement or to extend time performance by the said contractor(s) from time to time or to postpone for any time or from time to time any of the powers exercisable by BHEL against the said contractor(s) and to forbear or enforce any of the terms and conditions relating to the said agreement & we shall not be relieved from our liability by reason of any such variation, or extension being granted to the said contractor(s) or for any forbearance, act or omission on the part of BHEL or any indulgence by BHEL to said contractor(s) or by any such matter or thing whatsoever which under the law relating to sureties would, but for this provision, have effected of so relieving us.
6. This guarantee will not be discharged due to the change in the constitution of the Bank or the Contractor(s).
7. We,(indicate the name of the Bank) lastly undertake not to revoke this guarantee during its currency except with the previous consent of BHEL in writing.

Dated the Day of20...

For(indicate the name of the Bank)

WITNESS : 1)

2)

(SIGNATURE OF BANK REPRESENTATIVE WITH SEAL)

NOTE

1. The above format is drawn upon the model form jointly evolved by the Reserve Bank of India, the Indian Banks Association and the Ministry of Finance, Government of India as circulated by Indian Banks Association, Bombay vide their letter No. LA/14-61/808, dated 01.05.1980.
2. As such no deviations are acceptable.



BHARAT HEAVY ELECTRICALS LTD.,
TRANSMISSION BUSINESS GROUP, New Delhi
Conditions Of Contract For Civil Works, Doc.No.-TB-Civil-GCC, Rev-02

ANNEXURE – I

PROFORMA FOR PERFORMANCE GUARANTEE
(to be used in appropriate value non - judicial stamp paper)

1. This deed of guarantee made this day of 20... by Bank Limited in favour of Bharat Heavy Electricals Limited having their registered office at BHEL House, Siri Fort, New Delhi - 110 049.
2. Whereas M/s (hereinafter called the CONTRACTOR / SELLER have entered into a Contract bearing No. dated..... (hereinafter called the CONTRACT) for supply / civil works /erection, testing and commissioning of M/s Bharat Heavy Electricals Limited (hereinafter called the COMPANY).
3. And whereas the said CONTRACT Inter - alia provides that the CONTRACTOR / SELLER shall pay to the COMPANY a sum of Rs. only towards Performance Guarantee in the form and manner therein specified.
4. And whereas the SELLER / CONTRACTOR have approached Bank Limited (hereinafter referred to as the GUARANTOR) and at their request and in consideration of the arrangement arrived at between the CONTRACTOR and the GUARANTOR, the GUARANTOR has agreed to give the Guarantee as hereinafter mentioned in favour of the COMPANY.

NOW THIS DEED WITNESSES AS FOLLOWS:

5. The GUARANTOR by the hand of Mr. and its lawfully and fully constituted attorney and do hereby guarantee the due and faithful performance of the said CONTRACT and do hereby irrevocably undertake and promise to pay the COMPANY without any demur merely on demand made by them a sum not exceeding Rs. only in case the COMPANY sustains any loss or damage by reason of any breach, default by the CONTRACTOR / SELLER of any of the terms, conditions, stipulations or undertakings or any one of them contained in the said CONTRACT and the tender documents attached hereto and for payment of any moneys payable by the CONTRACTOR / SELLER to the COMPANY under the terms and conditions of the said CONTRACT. The decision of the COMPANY regarding the breach, default, loss, damage and payment shall be conclusive and binding in the GUARANTOR, irrespective of the fact whether the CONTRACTOR / SELLER admits or denies such claims or questions its correctness in any court, tribunal or arbitration proceedings or before any other authority.



BHARAT HEAVY ELECTRICALS LTD.,
TRANSMISSION BUSINESS GROUP, New Delhi
Conditions Of Contract For Civil Works, Doc.No.-TB-Civil-GCC, Rev-02

6. The COMPANY shall have the fullest liberty without effecting in any way the liability of the GUARANTOR under this guarantee, from time to time to vary any of the terms and conditions of the CONTRACT or extend time by the SELLER / CONTRACTOR or to postpone for any time and from time to time any of the powers exercisable by its against the SELLER / CONTRACTOR and either to enforce or forbear from enforcing any of terms and conditions governing the CONTRACT or securities available to the COMPANY and the GUARANTOR shall not be released from its liability under these presents by any exercise by the COMPANY of the liberty with reference to the matters aforesaid or by reason of time being given to the SELLER or any other forbearance, act or omission on the part of the COMPANY or any indulgence by the COMPANY to the SELLER / CONTRACTOR or of any other matter or thing whatsoever which under the law relating to sureties, would but for this provision have the effect of so releasing the GUARANTOR / CONTRACTOR from its liability under this Guarantee.
7. This Guarantee shall remain in full force and effect and the GUARANTOR shall be liable under the same irrespective of any concession or time being granted by the COMPANY to the CONTRACTOR in or for fulfilling the said CONTRACT and this Guarantee shall remain in full force irrespective of any change in terms and conditions, stipulations or any variations in the terms of CONTRACT irrespective of whether notice of such change and / or variation is given to the GUARANTOR or not and the claim to receive such notice of any change and or variation of the terms / or conditions of the CONTRACT is hereby specially waived by the GUARANTOR.
8. The GUARANTEE herein contained shall not be determined, prejudiced or effected by the liquidation or winding up or insolvency of or change in the constitution of the CONTRACTOR but shall in all respects and for all purposes be binding and operative until all payments or all moneys due or that may hereafter become payable to the COMPANY are paid in respect of any liability or obligation of the CONTRACTOR under the CONTRACT.
9. The GUARANTOR further agree that the Guarantee herein contained shall remain in full force and effect during the period that would be taken for the commencement of the CONTRACT till end of the CONTRACT and its claim satisfied or discharged and till the COMPANY certified that the terms and conditions of the CONTRACT have been fully and properly carried out by the SELLER and accordingly discharges this guarantee, subject, however, that the COMPANY shall have no claim under this Guarantee after months from the date of completion of the Guarantee has been served on the



BHARAT HEAVY ELECTRICALS LTD.,
TRANSMISSION BUSINESS GROUP, New Delhi
Conditions Of Contract For Civil Works, Doc.No.-TB-Civil-GCC, Rev-02

GUARANTOR before the expiry of the said period in which case the same shall be enforceable against GUARANTOR notwithstanding the fact that the same is enforced after expiry of said period.

The GUARANTOR undertake not to revoke this Guarantee during the period it is in force except with the previous consent of the COMPANY in writing and agree that any liquidation or winding up or insolvency or dissolution or any change in the constitution of the SELLER or the GUARANTOR shall not discharge the GUARANTOR's liability here under.

It shall not be necessary for the COMPANY to proceed against the SELLER before proceeding against the GUARANTOR and the Guarantee herein contained shall be enforceable against them notwithstanding any security which the company may have obtained or obtained from the SELLER shall at the time when proceedings are taken against the GUARANTOR here under be outstanding or unrealized.

The GUARANTOR hereby declare that it has power to execute this Guarantee and the executant has full powers to do so on its behalf under the proper authority granted to him/them by of the GUARANTOR.

10. Notwithstanding anything herein before contained, our liability under this Guarantee is restricted to Rs. (Rupees only) and will expire on and unless a claim in writing is presented to us or an action or suit to enforce the claim is filed against us, within six months from the date, all our rights shall be forfeited and we shall be relieved and discharged from all our liabilities thereunder.

IN WITNESS whereof the (Bank) have hereunto set and subscribed their hands the day, month and year first above written.

**SIGNED FOR AND ON
BEHALF OF THE BANK**

WITNESS:

NAME AND ADDRESS

SIGNATURE

1.

2.



BHARAT HEAVY ELECTRICALS LTD.,
TRANSMISSION BUSINESS GROUP, New Delhi
Conditions Of Contract For Civil Works, Doc.No.-TB-Civil-GCC, Rev-02

ANNEXURE - J

**REVISED PRICE OFFER IN LIEU OF WITHDRAWAL OF DEVIATIONS/
CLARIFICATIONS OFFERED BY BHEL**

Sl. No.	Clause Ref.	Description of Deviation/ Clarification	Whether Increase/ Decrease in Price	Unit Rate (if applicable)	Total Increase/ Decrease	Remarks

NOTE: Total increase or decrease in total price shall be indicated either in percentage or in value (Rs.).

(SIGNATURE OF TENDERER)
WITH STAMP



ANNEXURE - K

LIST OF LABORATORY TEST EQUIPMENTS

<u>SL. NO.</u>	<u>DESCRIPTION OF APPARATUS</u>	<u>CODE REF.</u>
01.	VICATS APPARATUS	IS-5513
02.	LE-CHATELIER'S TEST APPARATUS	IS-5514
03.	MOULD (CEMENT)	IS-10086
04.	CEMENT MORTAR MOULD VIBRATOR	IS-10078
05.	CONCRETE CUBE MOULDS	IS-10086
06.	COMPR. STRENGTH TEST M/C	IS-2505
07.	CONCRETE SLUMP CONE	IS-7320
08.	COARSE AGGR. SIEVES	IS-383
09.	FINE AGGR. SIEVES	IS-383
10.	AGGR. IMPACT TEST M/C	IS-9377
11.	(a) SOIL CORE COMPACTOR	IS-2720
	(b) PROCTOR COMPACTION	IS-29
12.	REBOUND HAMMER	
13.	THEODOLITE	
14.	DUMPY LEVEL WITH STAFF	
15.	OVEN	
16.	PHYSICAL BALANCE	
17.	AIR ENTERTAINMENT METER	ST-1199

(SIGNATURE OF TENDERER)
WITH STAMP



BHARAT HEAVY ELECTRICALS LTD.,
TRANSMISSION BUSINESS GROUP, New Delhi
Conditions Of Contract For Civil Works, Doc.No.-TB-Civil-GCC, Rev-02

ANNEXURE - L

(On Banks Letter Head)

To:

DGM (Finance)
Transmission Business Group,
2nd floor, Bharat Heavy Electricals Limited,
Integrated office Complex, Lodhi Road,
New Delhi 110 003

Ref & Date :

Sub : Confirmation of Bank Guarantee no. <<BG No. >>

We are a Scheduled Bank other than Co-operative Bank under the RBI Act 1934. The aforesaid BG No. << BG No. >> for Rs. <<BG Amount>>/ (In Words Also) and valid upto <<validity date>> is issued by us on behalf of M/s <<Beneficiary's Name>> in favour of BHARAT HEAVY ELECTRICALS LTD. – TRANSMISSION BUSINESS GROUP.

The format of the Bank Guarantee is strictly as per the format prescribed by M/s BHEL and the stamp paper forming part of the BG are as per the state rules extant.

The signatories to the Bank Guarantee are duly authorised.

Thanking You,

For and On Behalf of
Name of the Bank & Seal

(Please Sign Here)



SECTION-B

GENERAL TERMS AND

CONDITIONS



SECTION - B
GENERAL TERMS AND CONDITIONS

- B.1.0 The following terms shall have the meaning hereby assigned to them except where the context requires otherwise:-
- B.1.1 BHEL (or B.H.E. Ltd.) shall mean Bharat Heavy Electricals Limited, a Company registered under Indian Companies Act 1956, with its Registered Office at BHEL House, Siri Fort, New Delhi-110 049 or its Authorised Officers or its Engineers or other employees authorised to deal with any matters with which these persons are concerned.
- B.1.2 "GENERAL MANAGER" shall mean the Officer in Administrative charge of the Contracting Unit of BHEL.
- B.1.3 "ENGINEER" OR "ENGINEER-IN-CHARGE" shall mean Engineer deputed by BHEL. The term includes "Deputy General Manager, Construction Manager, Resident Engineer, Assistant Site Engineer of BHEL/at the site as well as the officers in charge at Head Office.
- B.1.4 "SITE" shall mean the place or places at which the plants/equipment are to be erected and services are to be performed as per the specification of this tender.
- B.1.5 "CLIENTS OF BHEL" or "CUSTOMER/OWNER" shall mean the organization to whom BHEL is responsible for this work.
- B.1.6 "CONTRACTOR" shall mean the individual, firm or Company who enters into this Contract with BHEL and shall include their executors, administrators, successors and assigns.
- B.1.7 "CONTRACT" or "CONTRACT DOCUMENT" shall mean and include the agreement, the work order, the accepted appendices of rates, Schedules of Quantities, if any, General Terms and Conditions of Contract, Special Conditions of Contract, Instructions to Tenderers, the drawings, the Technical Specifications, the Special Specifications, if any, the tender documents and the Letter of Intent\Accepting Letter issued by BHEL. Any conditions or terms stipulated by the tenderer in the tender documents or subsequent letters shall not form part of the Contract unless specifically accepted in writing by BHEL in the Letter of Intent and incorporated in the Agreement.



BHARAT HEAVY ELECTRICALS LTD.,
TRANSMISSION BUSINESS GROUP, New Delhi
Conditions Of Contract For Civil Works, Doc.No.-TB-Civil-GCC, Rev-02

- B.1.8 "GENERAL CONDITIONS OF CONTRACT" shall mean the "Instructions and Information for Tenderers and General terms and Conditions" pertaining to the work detailed.
- B.1.9 "TENDER SPECIFICATIONS" shall mean the Special Conditions, Technical Specifications, Appendices, Site Information and drawings pertaining to the work for which the tenderers are required to submit their offer. Individual Specification Numbers will be assigned to each tender specification.
- B.1.10 "TENDER DOCUMENTS" shall mean the General Conditions of Contract and Tender Specifications.
- B.1.11 "LETTER OF INTENT" shall mean the intimation by a letter/telegram/telex/fax to the tenderer that the tender has been accepted in accordance with provisions contained in the letter. The responsibility of the contractor commences from the date of issue of this letter and all the terms and conditions of contract are applicable from this date.
- B.1.12 "COMPLETION TIME" shall mean the period by date specified in the Letter of Intent/Work Order or date mutually agreed upon for handing over of the erected equipment/plant which are found acceptable by the Engineer being of required standard and conforming to the specifications of the contract.
- B.1.13 "ZERO DATE" shall mean the planned commencement date of work under this tender and shall be date of issue of Letter of Intent.
- B.1.14 "PLANT" shall mean and connote the entire assembly of the plant and equipment covered by the contract.
- B.1.15 "EQUIPMENT" shall mean all equipment, machineries, materials, structural, electricals and other components of the plant covered by the contract.
- B.1.16 "TESTS" shall mean and include such test or tests to be carried out by the contractor as are prescribed in the contract or considered necessary by BHEL, in order to ascertain the quality, workmanship, performance and efficiency of the contracted work or part thereof.
- B.1.17 "APPROVED" "DIRECTED" or "INSTRUCTED" shall mean approved, directed or instructed by BHEL.



BHARAT HEAVY ELECTRICALS LTD.,
TRANSMISSION BUSINESS GROUP, New Delhi
Conditions Of Contract For Civil Works, Doc.No.-TB-Civil-GCC, Rev-02

- B.1.18 "WORK OR CONTRACT WORK" shall mean and include supply of all categories of labour, specified consumables, tools and tackles required for complete and satisfactory site transportation, handling, stacking, storing, civil and electrical works, erection, testing and commissioning of the equipment to the entire satisfaction of BHEL.
- B.1.19 "SINGULAR AND PLURAL" etc. words carrying singular number shall also include plural and vice versa, where the context so requires. Words imparting masculine gender shall be taken to include the feminine gender and words imparting persons shall include any Company or Association or Body or Individuals, whether incorporated or not.
- B.1.20 "HEADINGS" The headings in these General Conditions are solely for the purpose of facilitating reference and shall not be deemed to be part thereof or be taken into consideration in the interpretation of construction thereof or the contract.
- B.1.21 "MONTH" shall mean calendar month.
- B.1.22 "WRITING" shall include any manuscript typewritten or printed statement under the signature or seal as the case may be.

B.2.0 LAW GOVERNING THE CONTRACT AND COURT JURISDICTION:

The Contract shall be governed by the Law for the time being enforce in the Republic of India. The Civil Court at Delhi having ordinary Original Civil Jurisdiction shall alone have exclusive jurisdiction in regard to all claims in respect of this contract.

B.3.0 ISSUE OF NOTICE:

The contractor shall furnish to the Engineer, the name, designation and address of his authorised agent and all complaints, notices, communications and references shall be deemed to have been duly given to the Contractor, if delivered to the Contractor or his authorised agent and shall be deemed to have been so given in the case of posting on the day on which they would have reached such address in the ordinary course of post or at which they were so delivered or left.

B.4.0 USE OF LAND:

No land belonging to BHEL or its customer under temporary possessions of BHEL shall be occupied by the contractor without the written permission of BHEL.



BHARAT HEAVY ELECTRICALS LTD.,
TRANSMISSION BUSINESS GROUP, New Delhi
Conditions Of Contract For Civil Works, Doc.No.-TB-Civil-GCC, Rev-02

B.5.0 COMMENCEMENT OF WORK:

- B.5.1 The contractor shall commence the work within fifteen days of Letter of Intent or the time indicated in the Letter of Intent/Work Order and shall proceed with the same with due expedition without delay.
- B.5.2 If the successful tenderer fails to commence the work within the stipulated time, BHEL, at its sole discretion will have the right to cancel the Letter of Intent/Contract. His Earnest Money and/or Security Deposit will stand forfeited without any further reference to him without prejudice to any and all of BHEL's other rights and remedies in this regard.
- B.5.3 All the works shall be carried out under the direction and to the satisfaction of BHEL/Customer/Owner.
- B.5.4 The transported equipment, erected/constructed plant or work performed under the contract, as the case may be, shall be taken over when it has been completed in all respect and/or satisfactorily put into operation at site.

B.6.0 MEASUREMENT OF WORK AND MODE OF PAYMENT:

- B.6.1 All payments due to the contractor shall be made only by "Account Payee Cheques".
- B.6.2 For progress/running bill payments, the contractor shall present detailed measurement sheets in triplicate duly indicating all relevant details based on technical documents, protocols & material test reports and connected drawings for the work done during the calendar month/period under different categories in line with terms of payment & as per Letter of Intent. The basis of arriving at the quantities/weights shall be the relevant documents and drawings released by BHEL. These measurement sheets shall be prepared jointly with Engineers of BHEL and signed by all parties.
- B.6.3 The measurement sheets will be checked by the Engineer and quantities & percentage eligible for payment under different groups shall be decided by him. The abstract of quantities and percentage so arrived at based on the terms of payment shall be entered in the Measurement Book & signed by both the parties. Where required counter signature of Customer/Owner shall have to be taken.



BHARAT HEAVY ELECTRICALS LTD.,
TRANSMISSION BUSINESS GROUP, New Delhi
Conditions Of Contract For Civil Works, Doc.No.-TB-Civil-GCC, Rev-02

- B.6.4 Based on the above quantities, contractor shall prepare the bills in the prescribed proforma and work out the financial value. These will be entered in the measurement Book and signed by both the parties. Payment shall be made by BHEL after effecting the recoveries due from the Contractor.
- B.6.5 All recoveries due from the contractor for the month/period shall be effected in full from corresponding running bills unless specific approval from Competent Authority is obtained to the Contrary.
- B.6.6 Measurement shall be taken jointly by person duly authorised by BHEL, Owner and the Contractor.
- B.6.7 The Contractor shall bear the expenditure involved, if any, in taking the measurements & testing of materials to be used in the works. The Contractor shall without extra cost to BHEL, provide all the assistance with appliances and other things necessary for measurement.
- B.6.8 If at any time due to any reason whatsoever, it becomes necessary to remeasure the work done, in full or in part, the expenses towards such re-measurement shall be borne by contractor.
- B.6.9 Passing of bills covered by such measurement does not amount to acceptance by BHEL of the completion of the work measured. Any left out work has to be completed by the Contractor, as directed by BHEL.
- B.6.10 Final measurement bill shall be prepared in the proforma prescribed for the purpose, based on the certificate issued by the Engineer that the entire work as stipulated in the tender specification has been completed in all respects to the entire satisfaction of BHEL.

The contractor shall give unqualified "No claim" and "No Demand" certificates. All the tools and tackles loaned to him should be returned in condition satisfactory to BHEL. The abstract of final quantities and financial values shall also be entered in the Measurement Book and signed by both the parties. The final bill shall be paid after completion of all the defects/deficiencies etc. pointed out by BHEL. The Contractor should submit all the original documents such as material consumption, site order book etc. maintained at site. After payment of final bill, only guarantee obligation percentage value shall remain unpaid, which shall be released in accordance with Clause A.17.7.



BHARAT HEAVY ELECTRICALS LTD.,
TRANSMISSION BUSINESS GROUP, New Delhi
Conditions Of Contract For Civil Works, Doc.No.-TB-Civil-GCC, Rev-02

B.7.0 RIGHTS OF BHEL:

Refer Annexure to GCC for Civil works



BHARAT HEAVY ELECTRICALS LTD.,
TRANSMISSION BUSINESS GROUP, New Delhi
Conditions Of Contract For Civil Works, Doc.No.-TB-Civil-GCC, Rev-02

B.8.0 RESPONSIBILITY OF THE CONTRACTOR IN RESPECT OF LOCAL LAWS, EMPLOYMENT OF WORKERS ETC:

The following are the responsibilities of the Contractor in respect of observance of local laws, employment of personnel, payment of taxes etc.

- B.8.1 As far as possible, unskilled workers shall be engaged from the local areas in which the work is being executed. In case of any necessity is felt by the contractor to bring labourers from out side State, provisions of law governing such immigration by the concerned State are to be followed.



BHARAT HEAVY ELECTRICALS LTD.,
TRANSMISSION BUSINESS GROUP, New Delhi
Conditions Of Contract For Civil Works, Doc.No.-TB-Civil-GCC, Rev-02

- B.8.2 The Contractor at all times during the currency of this contract, shall in all his dealings with the local labour for the time being employed on or in connection with the work, have due regard to all local festivals, religious and other customs.
- B.8.3 The contractor shall comply with all State and Central Laws, Statutory Rules, Regulations etc., such as: The payment of wages to, The Minimum Wages Act, The Workmen Compensation Act, The Employees Liability Act, The Industrial Dispute Act, The Employees Provident Fund Act, Employees State Insurance Scheme, The Contract Labour (Regulations and Abolition) Act 1970 and other Acts, Rules & Regulations for labour as may be enacted by the Government during the tenure of the contract and having in force or jurisdiction at site. The Contractor shall give to the local Governing Body, Police and other concerned Authorities all such notice as may be required under law.
- B.8.4 The contractor, as required, will obtain independent license under the Contract Labour (Regulations & Abolition) Act 1970 from the concerned authorities based on the certificate (Form-V) issued by the Principal Employer/Customer.
- B.8.5 The Contractor shall pay all taxes, fees, license charges, deposits, duties, tolls, royalty, commissions or other charges which may be Leviable on account of any of his operations connected with this contract. The Contractor is responsible to furnish documentary evidence towards GST Registration of the State wherein the site is located and any other documents as per GST Act which may be required from time to time by BHEL. The contractor should have to get the contract registered immediately after award of works as per rules and regulations of the State Government. The contractor shall file regular return as per statute of the State/Centre and should provide all information to BHEL as required for the assessment of the project concerned. In case BHEL is forced to make any of such payments, BHEL shall recover the same from the contractor either from moneys due to him or otherwise as deemed fit.
- B.8.6 Arrangements for the periodical visits of inspection agencies such as Electrical Inspector etc. to site, inspection certificates etc. will have to be made by the contractor at his cost. The contractor will also meet all expenses in connection with his welder's qualification/ re-qualification tests etc.
- B.8.7 The contractor shall be responsible for provision of health and sanitary arrangements {more particularly described in the Contract Labour (Regulation & Abolition) Act 1970} & safety precautions as may be required for safe and satisfactory execution of the contract.



BHARAT HEAVY ELECTRICALS LTD.,
TRANSMISSION BUSINESS GROUP, New Delhi
Conditions Of Contract For Civil Works, Doc.No.-TB-Civil-GCC, Rev-02

- B.8.8 The Contractor shall be responsible for proper accommodation including adequate medical facilities for the personnel employed by him.
- B.8.9 The Contractor shall be responsible for the proper behaviour and observance of all regulations by the staff employed by him.
- B.8.10 The contractor shall ensure that no damage is caused to any person/property of other parties working at site. If any such damage is caused, it shall be the responsibility of the contractor to make good the losses or compensate them.
- B.8.11 All the properties/equipment/components of BHEL/its customer loaned with or without deposit, to the contractor, shall remain the properties of BHEL/its customer. The contractor shall use such properties for the purpose of execution of this contract. All such properties/equipment/components shall be taken in to good condition unless notified to the contrary by the contractor within 48 Hrs. The Contractor shall return them in good conditions as and when required by BHEL/ its customer. In case of non-return, loss, damage repairs etc., the cost thereof, as may be fixed by the Engineer, will be recovered from the contractor.
- B.8.12 It shall not be obligatory on the part of BHEL to supply any tools and tackles or materials other than those specifically agreed to be given by BHEL. However, depending upon availability/possibility, BHEL/its customer's equipment and other materials may be made available to the contractor on payment of the hire charges as fixed by them, subject to the conditions laid down by BHEL/its Customer from time to time. Unless paid in advance, such hire and other charges shall be recovered from out of dues to the contractor or Security Deposit in one instalment. In case, BHEL provide the material like steel etc. for Subcontractors / Suppliers, handling charges @ 15% per annum or 1.25% per month or part thereof will be recovered from the contractor in addition to the actual procurement cost of material. The period for imposing handling charges is to be reckoned from the date of making payment/LR for lifting material to / by Subcontractor from authorized source, whichever is earlier to
- a) The date of LR for dispatch of finished product by the supplier / fabricator.
b) Till date of consumption by the contractor as recorded in the MB.
- B.8.13 The Contractor shall fully indemnify and keep indemnified BHEL/its customer against all claims of whatsoever nature arising during the course of execution of this contract.



BHARAT HEAVY ELECTRICALS LTD.,
TRANSMISSION BUSINESS GROUP, New Delhi
Conditions Of Contract For Civil Works, Doc.No.-TB-Civil-GCC, Rev-02

- B.8.14 In case the contractor is required to undertake any work outside the scope of this contract, the amount payable shall be as may be mutually agreed upon.
- B.8.15 Any delay in completion of works or non-achievement of periodical targets, due to reasons attributable to the contractor, will have to be compensated by the contractor either by increased manpower and resources or by working extra hours or more than one shift at no extra cost to BHEL.
- B.8.16 The contractor shall execute the work under the conditions usual to such construction work and in conjunction with numerous other operations at site and proceed in a manner that shall help in the progress of work at site as a whole.
- B.8.17 The contractor will be directly responsible for payment of wages to his workmen. A pay roll sheet giving details of all payments made to the workmen duly signed by the contractor's representative should be furnished to BHEL, with each running account bill.
- B.8.18 In case of any class of work for which there is no specification laid down in the contract, such work shall be carried out in accordance with the instructions and requirements of the Engineer.
- B.8.19 No levy, payment or charges made or imposed shall be impeached by reason of any clerical error or by reason of any mistake in the amount levied, demanded or charged.
- B.8.20 No idle labour charges will be admissible in the event of any stoppage of work resulting in the contractor's workmen being rendered idle due to any reason any time.
- B.8.21 The contractor shall take all reasonable care to protect the materials and the work till such time the place/equipment has been taken over by BHEL/its customer.
- B.8.22 The contractor shall not stop work or abandon the site for whatsoever reason or dispute, excepting for force majeure conditions. All problems/disputes shall be separately discussed and settled without affecting the progress of work. Stoppage or abandonment of work, other than under force majeure conditions, shall be treated as breach of work of contract and dealt with accordingly.



BHARAT HEAVY ELECTRICALS LTD.,
TRANSMISSION BUSINESS GROUP, New Delhi
Conditions Of Contract For Civil Works, Doc.No.-TB-Civil-GCC, Rev-02

- B.8.23 The contractor shall keep the area of work clean and shall remove debris etc. while executing day-to-day work. Upon completion of work, the contractor shall remove from the vicinity of works, all scrap, packing materials, rubbish, unused and other materials and deposit them in places specified by the Engineer. The contractor will also demolish all the hutments, sheds, offices etc. constructed & used by him and shall clean the debris. In the event of his failure to do so, the same will be arranged to be done by the Engineer and the expenses recovered from the contractor.
- B.8.24 The contractor shall execute the work in the most substantial and workman like manner in the stipulated time. Accuracy of work and timely execution shall be the essence of this contract. The contractor shall be responsible to ensure that the quality, assembly and workmanship conform to the dimensions and clearance given in the drawings and/or as per instructions of the Engineers.
- B.8.25 The contractor shall furnish progress reports on work at regular intervals as required by the Engineer.

B.9.0 **RESPONSIBILITIES OF CONTRACTOR IN RESPECT OF SAFETY OF MEN, EQUIPMENT, MATERIAL AND ENVIRONMENT:**

- B.9.1 All safety rules and codes applied by BHEL/its customer at site shall be observed by the contractor and his workmen without exception. The contractor shall be responsible for the safety of the equipment/materials and work to be performed by him and shall maintain all lights, fencing guards, signs etc. or other protections necessary for the purpose. Contractor shall also take such additional precautions as may be indicated from time to time by the Engineer, with a view to prevent pilferage, accidents, fire hazards etc. and suitable number of clerical staff, watch and ward, store keepers to take care of equipment, materials and construction tools & tackles shall be posted at site by the contractor till the completion of the work under this contract. The contractor shall arrange for such safety devices as are necessary for this type of work & carry out the requisite site tests of handling equipment, lifting tools, tackles etc. as per usual standards and practices.
- B.9.2 The contractor shall provide to its work force & ensure the use of required personal protective equipment as found necessary & as directed by the authorised BHEL officials.
- i) Safety helmets conforming to IS-2925 : 1984.
 - ii) Safety belts conforming to IS-3521 : 1983.
 - iii) Safety shoes conforming to IS-1989 : 1978.



BHARAT HEAVY ELECTRICALS LTD.,
TRANSMISSION BUSINESS GROUP, New Delhi
Conditions Of Contract For Civil Works, Doc.No.-TB-Civil-GCC, Rev-02

- iv) Eye and face protection devices conforming to IS-8520 : 1977 and IS-8940 : 1978.
- v) Hand and body protection devices conforming to IS-2573 : 1975, IS-6994 : 1973, IS-8807 : 1978 and IS-8519 : 1977.
- B.9.3 All tools, tackles, fitting appliances, material handling equipment, scaffolds, cradles, safety nets, ladders, equipment, etc. used by the contractor shall be of safe design and construction and maintained in good condition. However BHEL officials shall have the right to ban use of any of them or get them tested at their discretion. All electrical equipment, connections & wiring for construction power, its distribution & use shall conform to the relevant requirements of Indian Electricity Act and Rules. Only electricians licensed by the appropriate statutory authority shall be employed by the contractor to carry out electrical works.
- B.9.4 All electrical appliances including portable electric tools used by contractor shall have safe plugging system to source of power and be appropriately earthed.
- B.9.5 The contractor shall not use any hand lamp energised by electric power with supply voltage of more than 240 volts. For work in confined spaces, lighting shall be arranged with power source of not more than 240 volts.
- B.9.6 Where it becomes necessary to provide and/or store petroleum products, explosives, chemicals and liquid or gaseous fuel or any other substance that may cause fire or explosion, the contractor shall be responsible for carrying out such provision and/or storage in accordance with the rules and regulations laid down in the relevant Government Acts, such as Petroleum Act, Explosive Act, Petroleum & Carbides of Calcium Manual of the Chief Controller of Explosives, Government of India etc. Prior approval of the authorised BHEL official at the site shall also be taken by the contractor in all such matters.
- B.9.7 The contractor shall arrange at his cost appropriate illumination as required at all work spots for safe working, when natural day light may not be adequate for clear visibility.
- B.9.8 In case of a fatal or disabling injury/accident to any person at construction sites pertaining to this work, the victim and/or his/her dependents shall be compensated by the contractor as per statutory requirements. However, if considered necessary, BHEL shall have the right to impose appropriate financial penalty on the contractor & recover the same from payments due to the contractor for suitably compensating the victim and/or his/her dependents.



BHARAT HEAVY ELECTRICALS LTD.,
TRANSMISSION BUSINESS GROUP, New Delhi
Conditions Of Contract For Civil Works, Doc.No.-TB-Civil-GCC, Rev-02

Before imposing any such penalty, appropriate enquiry shall be held by BHEL giving opportunity to the contractor to present his case.

- B.9.9 In case of any damage to property due to lapse by the contractor, BHEL shall have the right to recover the cost of such damages from the payments due to the contractor.
- B.9.10 In case of any delay in the completion of a job due to mishaps attributable to lapses by the contractor, BHEL shall have the right to recover cost of such delay from the payments due to the contractor, after notifying the contractor suitably and giving him opportunity to present his case.
- B.9.11 If contractor fails to improve the standards of safety in its operation to the satisfaction of BHEL after being given reasonable opportunity to do so and/or if the contractor fails to take appropriate safety precautions or to provide necessary safety devices and equipment or to carry out instructions regarding safety issued by the authorised BHEL official, BHEL shall have the right to take the corrective steps at the risk and cost of the contractor after giving appropriate notice indicating the steps that would be taken by BHEL.
- B.9.12 The contractor shall submit report of all accidents, fires, property damaged and dangerous occurrences connected with his area of work or caused due to his action/inaction, to the authorised BHEL official immediately after such occurrence, but in any case not later than 12 hours of the occurrence.
- B.9.13 During the course of construction, alteration or repairs scrap lumbars with protruding nails, sharp edges etc. and all other debris including combustibles scrap shall be kept cleared from working areas, passage ways and stairs in and around site.
- B.9.14 Cylinders shall be moved by tilting and rolling them on their bottom edges. They shall not be intentionally/negligently dropped, struck or permitted to strike each other violently. When cylinders are transported by powered vehicles, they shall be secured in a vertical position.
- B.9.15 The contractor shall be responsible for the safe storage of his radioactive sources if same have been permitted to use.
- B.9.16 All contractor's supervisory personnel and sufficient number of workmen shall be trained for fire fighting and first aid duties and shall be assigned specific duties. Enough number of such trained personnel must be available during the tenure of the contract.



BHARAT HEAVY ELECTRICALS LTD.,
TRANSMISSION BUSINESS GROUP, New Delhi
Conditions Of Contract For Civil Works, Doc.No.-TB-Civil-GCC, Rev-02

- B.9.17 Contractor shall provide enough fire protecting equipment of the types and numbers at his office, stores, construction/erection site, other temporary structures, labour colony area etc. Access to such fire protection equipment shall be easy and kept open at all times. Compliance of the above requirement under fire protection system at project site shall in no way relieve the contractor of any of his responsibilities and liabilities to fire accident occurring. In the event of fire safety measures being not to BHEL's satisfaction, BHEL shall have option to provide the same and recover the cost plus incidentals from contractor's bills and/or impose penalty as deemed fit by the Engineer.
- B.9.18 Before commencing the work, the contractor shall appoint/nominate a responsible officer to supervise implementation of all safety measures and liaison with BHEL Engineer at site.
- B.9.19 If safety record of the contractor in execution of the awarded job is to the satisfaction of Safety Department of BHEL, issue of an appropriate certificate to recognise the safety performance of the contractor may be considered by BHEL after completion of the job.
- B.10.0 **CONSEQUENCES OF CANCELLATION:**
- B.10.1 Whenever BHEL exercises its authority to terminate the contract / withdraw a portion of work, the work may be got completed by any other means at the contractor's risk and cost provided that in the event of the cost of completion (as certified by the Engineer which shall be final and binding on the contractor) being less than the contract value, the advantage shall accrue to BHEL. If the cost of completion exceeds the money due to the Contractor under the Contract, the Contractor shall either pay the excess amount demanded by BHEL or the same shall be recovered from the contractor. This will be in addition to the forfeiture of Security Deposit & recovery of liquidated damages as per relevant clauses.
- B.10.2 In case BHEL completes the work under the provisions of this clause, the cost of such completion to be taken into account for determining the excess cost to be charged to the contractor shall consist of cost of materials purchased and/or labour provided by BHEL with an addition of such percentage to cover supervision and establishment charges as may be decided by BHEL.



BHARAT HEAVY ELECTRICALS LTD.,
TRANSMISSION BUSINESS GROUP, New Delhi
Conditions Of Contract For Civil Works, Doc.No.-TB-Civil-GCC, Rev-02

B.11.0 INSURANCE:

- B.11.1 BHEL/its customer shall arrange for insuring the project materials/properties of BHEL/its customer covering the risks during storage, construction, erection and commissioning.
- B.11.2 It shall be the sole responsibility of the Contractor to insure his workmen against risks of accident and injury while at work as required by the relevant rules and to pay compensation, if any, to them as per Workmen's Compensation Act. The Contractor shall also insure his staff against accidents. The work will be carried out in a protected area and all the rules and regulations of BHEL/its client in the project area which are in force from time to time will have to be followed by the contractor.
- B.11.3 If due to negligence and/or non-observance of safety and other precautions any accident/injury occurs to any other person/public, the contractor shall pay necessary compensation and other expenses, if so decided by the appropriate authority.
- B.11.4 It shall be the responsibility of the contractor to provide security and insurance claim related information/reports etc. for the equipment/material belonging to BHEL/its customer and handed over to the contractor for transportation/erection/construction till these are taken over by BHEL after erection/construction or are returned to BHEL/its customer's store.
- B.11.5 If due to Contractor's carelessness, negligence, non-observance of safety precautions, improper security arrangements or due to non-compliance of paper work needed for lodging insurance claim, damage to BHEL/its Customer's property and/or personnel should occur, and if BHEL is unable to recover its claim from the Insurance Company, the deficit will be recovered from the Contractor.

B.12.0 STRIKES & LOCKOUTS:

- B.12.1 The Contractor will be solely responsible for all disputes & other issues connected with his workmen. In the event of the contractor's workmen resorting to strike or the contractor resorting to lockout & if the strike or the lockout so declared is not settled within a period of one month, BHEL shall have the right to get the work executed by employing its own men or through other agencies or both. The cost incurred by BHEL in this regard shall be recovered from the Contractor.



BHARAT HEAVY ELECTRICALS LTD.,
TRANSMISSION BUSINESS GROUP, New Delhi
Conditions Of Contract For Civil Works, Doc.No.-TB-Civil-GCC, Rev-02

B.12.2 For any purpose whatsoever, the employees of the contractor shall not be deemed to be in the employment of BHEL/its Customer.

B.13.0 FORCE MAJEURE:

B.13.1 The following shall amount to force majeure conditions:-

Acts of God, Act of any Government, war, Sabotage, riots, civil Commotion, Police Action, Revolution, Flood, Fire Cyclone, Earthquake, Epidemic & other similar causes over which the contractor has no control.

B.13.2 If the contractor suffers delay in the due execution of the contract, due to delays caused by force majeure conditions, as defined above, the agreed time of completion of the work covered by this contract may be extended by a reasonable period of time in consultation and after agreement of BHEL's clients/owner, provided that on the occurrence of any such contingency, the Contractor immediately reports to BHEL in writing the causes of delay. The Contractor shall not be eligible for any compensation on this account.

B.14.0 GUARANTEE:

The guarantee and defect liability period shall be 12 months from the date of commissioning of switchyard or handing over of entire civil works, whichever is later.

B.15.0 ARBITRATION:

(i) Except as provide elsewhere in this Contract, in case amicable settlement is not reached between the Parties, in respect of any dispute or difference; arising out of the formation, breach, termination, validity or execution of the contract; or, the respective rights and liabilities of the Parties; or, in relation to interpretation of any provision of the contract; or, in relation to interpretation of any provision of the Contract; or, in any manner touching upon the contract, then, either Party may, by a notice in writing to the other Party refer such dispute or difference to the sole arbitration of an arbitrator appointed by Head of the BHEL Unit/Region/Division issuing the Contract.

The Arbitrator shall pass a reasoned award and the award of the Arbitrator shall be final and binding upon the Parties.



BHARAT HEAVY ELECTRICALS LTD.,
TRANSMISSION BUSINESS GROUP, New Delhi
Conditions Of Contract For Civil Works, Doc.No.-TB-Civil-GCC, Rev-02

Subject as aforesaid, the provisions of Arbitration and Conciliation Act 1996 (India) or statutory modifications or re-enactments thereof and the rules made thereunder and for the time being in force shall apply to the arbitration proceedings under this clause. The seat of arbitration shall be New Delhi.

The cost of arbitration shall be borne as per the award of the Arbitrator.

Subject to the arbitration in terms of clause L above, the court at New Delhi shall have exclusive jurisdiction over any matter arising out of or in connection with this Contract.

Notwithstanding the existence or any dispute or differences and/or reference for the arbitration, the Contractor shall proceed with and continue without hindrance the performance of its obligations under this contract with due diligence and expedition in a professional manner except where the contract has been terminated by either Party in terms of this contract.

(ii) In the event of dispute or difference relating to the interpretation and application of the provisions of commercial contract(s) between Central Public Sector Enterprises (CPSEs)/ Port Trusts inter se and also between CPSEs and Government Departments/ Organizations (excluding disputes concerning Railways, Income Tax, Customs & Excise Departments), such dispute or difference shall be taken up by either party for resolution through AMRCD as mentioned in DPE OM No.4(1)/2013-DPE9GM)/ FTS-1835 dated 22.05.2018.

SECTION-C

SPECIAL CONDITIONS **OF CONTRACT**

SECTION - C-1

SPECIAL CONDITIONS OF THE CONTRACT

C-1.0 INSTRUCTIONS TO TENDERERS:

C-1.1 The tenderers are advised to physically visit the site and fully acquaint themselves with site conditions, transportation routes, various distances etc. No claim will be entertained by BHEL on ground of lack of knowledge and the contractor's rates shall be deemed to have taken this into account.

C-1.2 All temporary structures, hutments etc. set up by the contractor or their workmen during execution shall be removed prior to submission of final bill by the contractor.

C-1.3 The contractor in the event of this work awarded to him, shall establish an office at site and keep posted an authorised, responsible officer with a valid power of attorney for the purpose of the contract. Any order or instructions of the "Engineer" or his duly authorised representatives, communicated to the contractor's representative at site will be deemed to have been communicated to the contractor at his official address.

C-1.4 The contractor is required to commence the work within two weeks from the date of issue of Letter of Intent or as indicated in the LOI/Work Order, failing which the LOI/contract is liable to be cancelled and EMD/SD shall be forfeited.

C-1.5 BHEL reserves the right to split up the work and to award to more than one contractor or award only a part of the work to a contractor.

C-2.0 PERFORMANCE BOND:

The contractor shall submit Bank Guarantee of an approved Nationalised Bank as per BHEL proforma for an amount equal to 2.5% of the contract value as performance bond to get his balance 2.5% payment released at the discretion of the engineer as per the general conditions of contract. The performance Bank Guarantee shall remain valid up to successful completion of performance and guarantee tests of the station and taking over of the plant by BHEL/client of BHEL. Notwithstanding the provisions of any other clause(s) of General Conditions of Contract, the contractor shall continue



BHARAT HEAVY ELECTRICALS LTD.,
TRANSMISSION BUSINESS GROUP, New Delhi
Conditions Of Contract For Civil Works, Doc.No.-TB-Civil-GCC, Rev-02

to be responsible to execute all such works of repair, rectification and making good of defects, imperfections of other faults as may be required of the contractor in writing by the Engineer for the period as stated above. The proforma for submission of the BG shall be as per Annexure I.

Above clause no. C-2.0 shall be read in conjunction with clause no. C-29.5.2.

C-3.0 SITE DRAINAGE:

All water which may accumulate on the site during the progress of the works, or in trenches and excavations, including monsoon period shall be removed by the contractor from the site to the satisfaction of the Engineer at the contractor's expense.

C-4.0 EXECUTION OF THE WORK:

C-4.1 The work will be executed in a workman like manner and to the entire satisfaction of the Engineer and as per technical specifications of this tender, IS Codes, CPWD specifications etc. as applicable. In case of conflict regarding interpretations the decision of the Engineer shall be final and binding.

C-4.2 The Engineer will communicate or confirm his instructions to the contractor in respect of the execution of the work in a "Site Order Book" maintained at his office and confirm issue of such instructions by signing the relevant entries in this book. Such entries will rank as order or notices in writing within the intent and meaning of these conditions.

C-5.0 INSPECTION AND STAGE APPROVAL OF THE WORK:

C-5.1 BHEL/BHEL's Client or the owner or his duly authorised representative shall have at all reasonable times access to the contractor's premises of works and shall have the power to inspect drawings or any portion of the work, examine the materials and workmanship and shall have the authority to reject any work. This would be implemented through joint inspection by the representatives of the owner and BHEL and in the form the joint protocol without any extra claim of time and amount.

C-5.2 All work embracing more than one process shall be subject to examination and approval at each stage thereof and the contractor shall give due notice in writing to the Engineer when each stage is ready. In default of such notice being received, Engineer shall be entitled to approve the quality and extent thereof at any time he may choose and in the event of any dispute, the decision of the Engineer thereon shall be final and conclusive.



BHARAT HEAVY ELECTRICALS LTD.,
TRANSMISSION BUSINESS GROUP, New Delhi
Conditions Of Contract For Civil Works, Doc.No.-TB-Civil-GCC, Rev-02

C-6.0 COMPLETION OF WORK:

C-6.1 The works shall be completed to the entire satisfaction of the Engineer and in accordance with the completion schedule as specified & agreed in the contract, and all unused stores and materials, tools, plant and equipment, temporary buildings and things shall be removed and the site work cleared of rubbish and all waste materials and delivered up clean and tidy to the satisfaction of the Engineer at the contractor's expenses.

C-6.2 BHEL shall have power to take over from the contractor from time to time such sections of the work as have been completed to the satisfaction of the Engineer. Such works however shall not be treated as have been completed until the entire works are executed to the satisfaction of the Engineer. The Guarantee period shall commence only after handing over the entire works.

C-7.0 UNCOVERING AND ADJUSTMENT OF ERRORS:

The contractor shall uncover any part of the works and/or make openings in or through the same as the Engineer may from time to time direct for his verification and shall reinstate and make good such part to the satisfaction of the Engineer. If any such part has been covered up or put out of view after being approved by the Engineer and is subsequently found on uncovering to have been executed in accordance with the contract, the expenses of uncovering and/or making opening in or through, reinstating and making good the same shall be borne by BHEL. In any other case all such expenses shall be borne by the contractor.

C-8.0 DISCREPANCIES AND ADJUSTMENT OF ERRORS:

C-8.1 The several documents forming the contract are to be taken as mutually explanatory of one another, detailed drawings being followed in preference to small scale drawings & figures dimensions in preference to scale & special conditions in preference to general conditions.

C-8.2 In case of discrepancies between schedule of quantities, the specification and/or the drawings the following order of preference shall be observed :

- a) Description in Schedule of Quantities.
- b) Special Conditions.
- c) Drawings.
- d) Technical Specifications.
- e) General Conditions of Contract.



BHARAT HEAVY ELECTRICALS LTD.,
TRANSMISSION BUSINESS GROUP, New Delhi
Conditions Of Contract For Civil Works, Doc.No.-TB-Civil-GCC, Rev-02

- C-8.3 If there are varying or conflicting provisions made in any one document forming part of the contract, the Engineer shall be the deciding authority with regard to the document.
- C-8.4 Any error in the description, quantity in schedule of quantities or any omission there from shall not vitiate the contract or release the contractor from the execution of the whole or any part of the works comprised therein according to the drawings and specifications or from any of his obligations under the contract.
- C-8.5 If on check there are found to be differences between the rates given by the contractor in words and figures or in the amount worked out by him in the schedule of quantities and general summary, the same shall be adjusted in accordance with the following rules :
- a) In the event of discrepancies between description in words and figures quoted by tenderer, the description in words shall prevail.
 - b) In event of an error occurring in the amount column of schedule of quantities as a result of wrong extension of the unit rate and the quantity, the unit rate shall be regarded as firm and extension shall be amended on the basis of the rates.
 - c) All errors in totalling in the amount column and in carrying forward totals shall be corrected.
 - d) The totals of sections of bill of quantities amended shall be carried over to the general summary and the tendered sum amended accordingly. The tendered sum so altered shall, for the purpose of tender, be substituted for the sum originally tendered and considered for acceptance instead of the original sum quoted by the tenderer. Any rounding of quantities or in sections of bill of quantities or in general summary, by the tenderer, shall be ignored.
- C-8.6 If neither drawings nor specifications contain any mention of minor details of construction which in the opinion of the Engineer, whose decision shall be final and conclusive, are reasonable and obviously and fairly intended for satisfactory completion of work, such details shall be provided by the contractor without any extra cost, as if they were specially mentioned and shall be deemed to be included in the contract.



BHARAT HEAVY ELECTRICALS LTD.,
TRANSMISSION BUSINESS GROUP, New Delhi
Conditions Of Contract For Civil Works, Doc.No.-TB-Civil-GCC, Rev-02

C-9.0 DEVIATIONS:

C-9.1 The contractor shall not make any alternation in, addition to or omission from the work as described in the tender documents except in pursuance of the written instructions of the Engineer. No such deviation from the work described in the tender documents shall be valid unless the same has been specially confirmed and accepted by the Engineer in writing and incorporated in the contract.

C-9.2 The engineer may deviate, either by way of addition or deletion, from the work so described, provided that the contract sum be not thereby varied on the whole by more than the percentage set out in the tender documents. The value of all additions and deletions shall be added to or deleted from the contract sum.

C-9.3 Any objections by the contractor to any matter concerning the order shall be notified by him in writing to the Engineer within 7 (seven) days from the date of such order, but under no circumstances shall the work be stopped (unless so ordered by the Engineer) owing to differences or controversy that may arise from such an objection. In the absence of such a notification of objection by the contractor, he will be deemed to have accepted the order and conditions stated therein.

C-10.0 VALUATION OF DEVIATIONS:

C-10.1 If the rates for the additional, altered or substituted work are specified in the contract for the work either in the same section or in the other section of the BOQ of the same work, the contractor is bound to carryout the additional, altered or substituted work at the same rates as are specified in the contract for the work.

C-10.2 For item which are required for successful completion of work but not covered in the BOQ:- if items are available in DSR -2016, then valuation shall be done at DSR rate (DSR 2016) along with applicable % as per contract and same shall be binding to the bidder.

C10.2.1 EXTRA/ ADDITIONAL ITEMS OF WORK

If any extra or additional items, which are not incorporated in the BOQ schedule, have to be executed by the contractor, the rate of such extra or additional work shall be as per the following:



BHARAT HEAVY ELECTRICALS LTD.,
TRANSMISSION BUSINESS GROUP, New Delhi
Conditions Of Contract For Civil Works, Doc.No.-TB-Civil-GCC, Rev-02

- C10.2.2 If the items are not covered under price schedule, the rates have to be agreed upon mainly on the basis of prevailing market rates for which all documentary evidences as required by BHEL shall have to be produced by the contractor. Decision of BHEL in such cases shall be final and binding on the contractor.
- C-10.2.3 Under no circumstances the contractor shall suspend the work on the plea of non- settlement of rates falling under the clause or claim any compensation on that account.
- C-10.2.4 BHEL reserves the right to carry out such extra/additional items of work through any other contractor or in such a manner as he considered advisable.
- C-10.2.5 The contractor, on receipt of drawing from BHEL, shall inform BHEL (within 15 days) the rate / rates of item/items for carrying out the extra/additional item of work. This shall be supported by analysis of rates including prevailing market rates.
- C--10.2.6 If the rate for additional, altered or substituted work is available in DSR 2016 then the rate shall be settled as per clause no. C-10.2.
- C-10.3 Variation in quantity of work: - There may be variations in the individual item in the schedule during actual execution of the work. However, tendered unit rates shall remain firm up to a variation of $\pm 30\%$ of the total value of the contract irrespective of variations in the quantity of individual items.
- C-11. **RECORD AND MEASUREMENT:**
- C-11.1 All items having a financial value shall be entered in BHEL measurement book so that a complete record is obtained of all works performed under the contract.
- C-11.2 Work which fails to be measured in details shall be measured physically without reference to any local custom that may obtain excepting where it may otherwise be directed in the tender documents. The measurements shall be taken jointly by any person duly authorised on the part of BHEL and the contractor.
- C-11.3 The contractor shall, without extra charge, provide assistance with appliances and other things necessary for measurement and shall bear all the cost of measurement of his work.



BHARAT HEAVY ELECTRICALS LTD.,
TRANSMISSION BUSINESS GROUP, New Delhi
Conditions Of Contract For Civil Works, Doc.No.-TB-Civil-GCC, Rev-02

- C-11.4 Measurement shall be entered in BHEL measurement book and signed and dated by both parties at the site on completion of measurement. If the contractor objects to any of the measurements recorded on behalf of BHEL, a note to that effect will be made in BHEL measurement book or against the item or items objected to and such note shall be signed and dated by both the parties engaged in taking the measurement.
- C-11.5 If, as result of such objection, it becomes necessary to remeasure the work wholly or in part, the expense of such measurement shall be borne by the contractor.
- C-11.6 If the contractor's representative fails to attend when required, the engineer shall have power to proceed by himself to take measurements & in that case these measurements shall be accepted by the contractor as final.
- C-11.7 The contractor shall, once in every month, submit to the Engineer details of his claims for the work done by him up to and including the previous month, which are not covered by this contract agreement in any of the following respects:
- a) Deviations from items and specifications provided in the contract documents.
 - b) Extra item/new items of work.
 - c) Quantities in excess of those provided in the contract schedule.
 - d) Items in respect of which rates have not been settled.
- C-11.8 Contractor should, in addition, furnish a clear certificate to the effect that the claims submitted by him as aforesaid cover all his claims and that no further claims shall be raised by him in respect of the work done up to and including the period under report.
- C-12.0 **CONTRACTOR'S SUPERVISION:**
- C-12.1 The contractor shall either himself supervise the execution of the contract or shall appoint a competent agent approved by the Engineer to act in his stead.
- C-12.2 The contractor, shall employ an engineer/agent having qualification in Civil Engineering from a recognised Institute for any work with a contract value exceeding Rs. Two Lakhs.
- C-12.3 If the contractor fails to appoint a suitable engineer/agent as aforesaid, the Engineer shall have full powers to suspend the execution of work & stop payment of any amount that may have become due until such date as a



BHARAT HEAVY ELECTRICALS LTD.,
TRANSMISSION BUSINESS GROUP, New Delhi
Conditions Of Contract For Civil Works, Doc.No.-TB-Civil-GCC, Rev-02

suitable engineer/agent is appointed and the contractor shall be held responsible for the delay caused to the work & no extension of time on this account shall be given to him.

- C-12.4 Orders given to the contractor's engineer/agent shall be considered to have the same force as they had been given to the contractor himself.
- C-12.5 The contractor or his agent shall be in attendance at the site during all working hours and shall superintend the execution of work with such additional assistance in each trade as the Engineer may consider necessary.
- C-12.6 The contractor or his agent shall attend, when required and without making claim for doing so, either the office of the Engineer or work site to receive instructions.
- C-12.7 The Engineer shall have full powers, and without assigning any reason, to require the contractor immediately to cease to employ in connection with this contract any agent, servant or employee whose continued employment, in his opinion, undesirable.

C-13.0 **LABOUR AND SUPERVISION STAFF:**

- C-13.1 The contractor shall engage experienced supervisory staff and specially skilled labour for work under this contract.
- C-13.2 The contractor shall have to make his own arrangement for maintenance of his T and P so as to minimise the down time.
- C-13.3 The supervisory staff employed by the contractor shall ensure proper out-turn of the work and discipline on the part of the labour put on the job. The contractor in general should see that the works are carried out in a safe and proper manner and in coordination with the staff employed directly by BHEL or other contractors of BHEL or its client.
- C-13.4 It shall be the responsibility of the contractor to ensure safe working, taking due precautions to avoid any accident and damage to other equipment and personnel. He shall be liable for all accidents, damages etc. to personnel and equipment etc. during the execution of the work.
- C-13.5 The work shall be executed under the usual conditions like rain, insufficient space, improper approach roads etc. affecting major construction work and in conjunction with numerous other operations at site. The contractor and his personnel shall cooperate with the others and proceed in a manner that shall



BHARAT HEAVY ELECTRICALS LTD.,
TRANSMISSION BUSINESS GROUP, New Delhi
Conditions Of Contract For Civil Works, Doc.No.-TB-Civil-GCC, Rev-02

not delay or hinder the progress of work as a whole nor claim any compensation on such grounds.

C-13.6 The contractor will arrange necessary accommodation for his supervisory and workmen at his own cost. However, BHEL will approach customer for accommodation for contractor's staff and labour on chargeable basis, if possible.

C-14.0 PLANT AND EQUIPMENT AT SITE:

C-14.1 The contractor shall, at his own expenses, supply all tools, plant and equipment (hereinafter referred as T and P), testing instruments and consumables required for the execution of the contract.

C-14.2 All tools, plant & equipment brought to the site shall become the property of the BHEL & shall not be removed from the site without the written approval of the Engineer. When the work is finally completed or the contract is terminated for reasons other than the default of the contractor, he shall forthwith remove from the site all tools, plant, equipment etc. (other than those as may have been provided by BHEL) and upon such removal, the same shall revert in & become the property of the contractor.

C-15.0 COMPLIANCE TO REGULATIONS AND BY LAWS:

C-15.1 The contractor shall conform to the provisions at any statute relating to the work and regulations and bylaws of any local authority and of any water and lighting companies or undertaking with whose system the work is proposed to be connected. He shall before making any variation from the drawings or the specifications that may be necessitated for such connections give the Engineer, notice specifying the variation proposed to be made & the reasons thereof & shall not carry out any such variation until he has received instructions from the Engineer in respect thereof. The contractor shall be bound to give all notices required by statute, regulations or by laws as aforesaid and to pay all fees and taxes payable to any authority in respect thereof.

C-16.0 MATERIALS OBTAINED FROM EXCAVATION:

C-16.1 Materials of any kind obtained from excavation on the site shall remain in property of BHEL & shall be disposed of as the Engineer may direct, at no extra cost.



BHARAT HEAVY ELECTRICALS LTD.,
TRANSMISSION BUSINESS GROUP, New Delhi
Conditions Of Contract For Civil Works, Doc.No.-TB-Civil-GCC, Rev-02

C-17.0 TREASURE, TROVE, FOSSILS, ETC:

All fossils, coins, articles of value or antiquity and structures and other remains or things of geological or archaeological interest discovered on the site shall be the absolute property of BHEL and the contractor shall take reasonable precautions to prevent his workmen or any other person from removing or damaging any such article or thing, shall immediately upon discovery thereof and before removal acquaint the Engineer with such discovery and carry out the Engineer's directions as to the disposal of the same.

C-18.0 PROTECTION AND SECURITY:

The contractor shall provide and maintain at his own expenses all lights, guards, fencing and Watch & Ward when and where necessary or required by Engineer for the protection and security of the works or for the safety and convenience of those employed on the works or the public.

C-19.0 SITE OFFICE AND STORES:

C-19.1 BHEL shall provide to the restricted extent, open space as made available to BHEL by its customer in as is where is basis for site office and stores, free of charge.

C-19.2 The contractor shall provide, construct and maintain at his own expenses the site office, material testing laboratory, stores & shall make his own arrangements for water, sanitation, access roads, electrification and cleanliness required for proper and efficient execution of work. The planning, setting and construction of these buildings shall have the approval of the Engineer & the contractor shall keep them tidy, clean and in sanitary condition to the satisfaction of Engineer.

C-19.3 After completion of work the contractor shall promptly dismantle, the distribution and other facilities that may have been erected, at his own cost and clear the area to the satisfaction of the Engineer and hand over the same to the Engineer.

C-20.0 POWER & WATER :- **DELETED**

~~C-20.1 The Construction Power shall be provided at one point on chargeable basis and recovery shall be made on actuals at the rate prevailing at the time of drawl of~~



BHARAT HEAVY ELECTRICALS LTD.,
TRANSMISSION BUSINESS GROUP, New Delhi
Conditions Of Contract For Civil Works, Doc.No.-TB-Civil-GCC, Rev-02

power from RA bills as per Customer/BHEL norms. The contractor shall have to make their own arrangements, at their cost for distribution to various locations for their works including proper switch/fuse units, distribution boards, cables, poles etc. to ensure safety of men and equipment. Where required, the contractor shall employ diesel operative equipment in addition to electric operated ones to ensure timely completion of work.

In case BHEL is not able to supply power, contractor has to make his own arrangement and take a separate connection for all construction works.

BHEL shall not be responsible for any inconvenience caused due to any failure of lighting and power supply and no compensation for delay in works can be claimed by the contractor due to such non-supply on the grounds of idle labour, machinery or any other grounds. The contractor should ensure that the work in critical areas is not held up in the event of lighting and power breakdown and for the same he should have some stand by arrangement at his cost. In the event of breakdown in the electric supply, if the progress of work is hampered, it will be the responsibility of the contractor to step up the progress after restoration of electric supply so that over all progress of work is not affected. The contractor shall make proper arrangement of illumination at work place while working in late hours or in darkness.

C-20.2 Unless stated otherwise in the scope, The contractor shall make his own adequate arrangement for procuring clear water to be used in works at his own cost. However, water if available may be supplied to the contractor at one point on chargeable basis and recovery shall be made on actuals at the rate prevailing at the time of drawl of water from RA bills as per Customer/BHEL norms.

C-21.0 **TEMPORARY WORKSHOP, STORES, CONSUMABLES ETC:**

The contractor shall during the progress of work, provide, erect and maintain at his own expenses all necessary temporary workshops, stores, consumables, offices etc. required for the proper and efficient execution of the work. The planning, setting & erection of these buildings shall have the approval of the Engineer and the contractor shall at all time keep them tidy & in a clean and sanitary condition on to the entire satisfaction of the Engineer.

C-22.0 **MATERIALS:**

C-22.1 The contractor shall at his own expenses, provide all materials required for the work. All materials to be provided by the contractor shall be in conformity with the specifications laid down in the contract & the contractor shall, if



BHARAT HEAVY ELECTRICALS LTD.,
TRANSMISSION BUSINESS GROUP, New Delhi
Conditions Of Contract For Civil Works, Doc.No.-TB-Civil-GCC, Rev-02

requested by the Engineer, furnish proof to the satisfaction of the Engineer that the materials so comply.

- C-22.2 The contractor shall, at his own expenses and without delay, supply to the Engineer samples of materials proposed to be used in the works. The Engineer shall within seven days of supply of samples or within such further period as he may require, intimate to the contractor in writing, whether samples are approved by him or not. If samples are not approved, the contractor shall forthwith arrange to supply to the Engineer for his approval fresh samples complying with the specifications laid down in the contract. Any delay in approval of samples (original or fresh ones) shall not make the contractor eligible for any compensation.
- C-22.3 The Engineer shall have full powers to require removal of any or all of the materials brought to site by the contractor which are not in accordance with the contract specifications or do not conform in character or quality to samples approved by him. In case of default on the part of contractor in removing rejected materials, the Engineer shall be at liberty of have them removed by other means. The Engineer shall have full powers to procure other proper materials to be substituted for rejected materials and in the event of the contractor refusing to comply, he may cause the same to be supplied by other means. All costs, which may attend upon such removal and/or substitution shall be borne by the contractor. In such cases, handling charges @ 15% per annum or 1.25% per month or part thereof will be recovered from the contractor in addition to the actual procurement cost of material. The period for imposing handling charges is to be reckoned from the date of making payment / LR for lifting material to / by Subcontractor from authorized source, whichever is earlier to
- a) The date of LR for dispatch of finished product by the supplier / fabricator.
b) Till date of consumption by the contractor as recorded in the MB.
- C-22.4 The contractor shall indemnify BHEL, its representative or employees against any action, claim or proceeding relating to infringement or use of any patent or design or any alleged patent or design rights and shall pay any royalties or other charges which may be payable in respect of any article or materials or part thereof included in the contract. In the event of any claim being made or action being brought against BHEL or any agent, servant or employee of BHEL in respect of any such matters as aforesaid, the contractor shall immediately be notified thereof, provided that such indemnity in complying with the specific directions issued by BHEL but the contractor shall by any royalties or other charges payable in respect of any such use, the amount so



BHARAT HEAVY ELECTRICALS LTD.,
TRANSMISSION BUSINESS GROUP, New Delhi
Conditions Of Contract For Civil Works, Doc.No.-TB-Civil-GCC, Rev-02

paid being reimbursed to the contractor only if the use was the result of any drawings and/or specifications issued after submission of the tender.

- C-22.5 All charges on account of octroi, royalty and all other taxes & duties on materials obtained for the works from any source shall be borne by the contractor.
- C-22.6 The Engineer shall be entitled to have tests carried out as specified in the contract for any materials supplied by the contractor other than those for which, as stated above, satisfactory proof has already been furnished, at the cost of the contractor & the contractor shall provide at his expenses all facilities which the Engineer, may require for the purpose. If no test are specified in the contract, and such tests are required by the engineer, the contractor shall provide all facilities required for the purpose and the charges for these tests shall be by the contractor only. The cost of materials consumed in tests shall be borne by the contractor in all cases except when otherwise provided.
- C-23.0 **GENERAL:**
- C-23.1 Material required for works, shall be stored by the contractor only at places approved by the Engineer. Proper storage and safe custody of material including construction stores shall be the responsibility of the contractor for which no charges shall be claimed by the contractor.
- C-23.2 BHEL's officials concerned with the contract shall be entitled at any time to inspect and examine any materials intended to be used in or on the works, either on the site or at factory or workshop or other place(s) where such materials are assembled, fabricated, manufactured or at any place(s) where these are laying or from which these are being obtained and the contractor shall give such facilities as may be required for such inspection and examination.
- C-23.3 All materials brought to the site shall become and remain the property of BHEL and shall not be removed off the site without the prior written approval of the engineer. But whenever the works are finally completed and advance, if any, in respect of any such material is fully recovered, the contractor shall at his own expense forthwith remove from the site all surplus material originally supplied by him and upon such removal, the same shall revert in and become the property of the contractor.



BHARAT HEAVY ELECTRICALS LTD.,
TRANSMISSION BUSINESS GROUP, New Delhi
Conditions Of Contract For Civil Works, Doc.No.-TB-Civil-GCC, Rev-02

~~C-24.0~~ **DELAY AND EXTENSION OF TIME:**

~~If, in the opinion of the Engineer, the work is delayed~~

- ~~i) by reason of abnormally bad weather, or~~
- ~~ii) by reason of serious loss or damage by fire, or~~
- ~~iii) by reason of civil commotion, local combination of workmen, strike or lockout, affecting any of the trades employed on the work, or~~
- ~~iv) by delay on the part of the agency or tradesman engaged by the BHEL in executing work not forming part of the contract, or~~
- ~~v) by reason of any other cause which in the absolute discretion of the Engineer is beyond the contractor's control, then in any such case, the Engineer (or higher authority) may make fair and reasonable extension in the completion dates of the individual items of work of the contract as whole. Such extension which will be communicated to the contractor by the Engineer in writing shall be final and binding on the contractor. No other claim in this respect for compensation, idle labour or otherwise howsoever is admissible. Upon the happening of any such event causing delay the contractor shall immediately give notice thereof in writing to the Engineer but shall nevertheless use constantly his best endeavour to prevent or make good the delay and shall do all that may reasonably be required to the satisfaction of the Engineer to proceed with the work.~~

Above clause No. C-24.0 stands deleted. Please refer Annexure to conditions of contract for civil

C-25.0 COMPENSATION/ PENALTY FOR DELAY IN COMPLETION:

If the contractor fails to complete the works within the specified contractual period or extension of time granted by the Engineer, the BHEL shall have the right to deduct liquidated damage/penalty @ 0.5% of the contractual value per week of delay or part thereof, subject to a maximum of 10% of the contract value ;

. Once the maximum limit of delay is reached (i.e. 20 week of delay) BHEL may consider termination of the contract and forfeit the Security deposit without prejudice to the other remedies under the contract. Amended/ revised contract value (Excluding ORC, Extra Works, Supplementary/ Additional Items and PVC) shall be considered for calculating LD/ penalty.



BHARAT HEAVY ELECTRICALS LTD.,
TRANSMISSION BUSINESS GROUP, New Delhi
Conditions Of Contract For Civil Works, Doc.No.-TB-Civil-GCC, Rev-02

C-26.0 PRICE VARIATION:

DELETED



BHARAT HEAVY ELECTRICALS LTD.,
TRANSMISSION BUSINESS GROUP, New Delhi
Conditions Of Contract For Civil Works, Doc.No.-TB-Civil-GCC, Rev-02

DELETED

Above clause No. C-26.0 stands deleted. Please refer Annexure to conditions of contract for civil works.

C-27.0 **OVER RUN CHARGES:**

C-27.1
DELETED

Above clause No. C-27.0 stands deleted. Please refer Annexure to conditions of contract for civil works.

C-28.0 **OCTROI AND OTHER DUTIES:**

C-28.1 All charges on account of Octroi and/or other duties on materials obtained for the work shall be borne by the contractor.



BHARAT HEAVY ELECTRICALS LTD.,
TRANSMISSION BUSINESS GROUP, New Delhi
Conditions Of Contract For Civil Works, Doc.No.-TB-Civil-GCC, Rev-02

C-29.0 TERMS OF PAYMENT::

- C-29.1 ~~The contractor shall be paid monthly running bill to a maximum of 95% (retaining 5% from each running bill) of value of the works actually executed on site provided the work has been executed to the satisfaction of the Engineer. The payment for tender work shall be admitted progressively on completion of work. However, work is to be executed as per time schedule prescribed by Engineer-In-Charge. In case of delay due to contractor, payment made equivalent to amount of work done in tower, equipment and trenches will be withheld from successive bills. From payable amount recoveries such as security deposit, income tax etc. would be made as per rule. The certificate of the Engineer regarding such approval and passing of sums so payable shall be final and conclusive against the contractor~~
- C-29.2 The Engineer shall after a measured bill allow and certify payment to the contractor on the basis of abstract measurement bill submitted by contractor. However, the usual recoveries would be effected from bill.
- C-29.3 Any certificate relating to the work done may be modified by any subsequent interim certificates or by the final certificate and no certificate of the Engineer supporting an advance payment shall of itself be conclusive evidence that any work or materials to which it relates are in accordance with the contract.
- C-29.4 All intermediate payments shall be regarded as advance against the final payment only and shall not be considered as an admission of the due performance of the contract or any part thereof in any respect of the occurring of any claim whatsoever. Such intermediate payments shall not conclude, determine or effect in any way the powers of the Engineer as to the final settlement and adjustment of the account of otherwise, or in any way vary of affect the contract. To this affect the contractor shall submit the final bill, which shall contain the complete up-to-date measurements for the total work done.
- C-29.5 The conditions for the release of last 5% retention money shall be as follows:
- C-29.5.1 2.5% payment shall be released along with the final bill on completion of total work as certified by BHEL site.



BHARAT HEAVY ELECTRICALS LTD.,
TRANSMISSION BUSINESS GROUP, New Delhi
Conditions Of Contract For Civil Works, Doc.No.-TB-Civil-GCC, Rev-02

C-29.5.2 Balance 2,5% of payment shall be released on completion of guarantee period. However these retention money can be released on submission of B.G. of equivalent amount valid till guarantee period.

The contractor shall guarantee the work under the scope of the contract for a period of 12 months from the date of start of the guarantee period as certified by BHEL site (i.e completion of total work under the scope and or taking over by BHEL/owner), and shall rectify free of cost all defects due to faculty supply or work done. In case the contractor fails to repair/ replace the defective work within the time specified by BHEL, BHEL may proceed to undertake such repair/replace such defective work at contract's risk and cost without prejudice to any other right and recover the sum from security deposit/BG/ any dues.

Above clause No. C-29.5.2 shall be read in conjunction with clause no. C-2.0.

C-29.6 Income Tax at the prevailing rate on gross value of work done and applicable surcharge shall be deducted from the running account bills unless exempted by the Income Tax Office.

C-29.7 **The prices to be quoted by bidder should be EXCLUSIVE of GST**

Please refer Annexure to conditions of contract for civil works for detail terms and conditions of taxes & duties.

C-30.0 **CEMENT AND STEEL: (Pl. also refer Annexure to conditions of contract for civil works for issue of Cement and steel in case of BHEL supply as mentioned in BOQ)**

C-30.1 The theoretical quantity of cement to be used in works shall be calculated on the basis of the designed mix concrete and as per CPWD norms for all the other items based on latest edition in use in CPWD works Delhi at the time of submitting tender.

C-30.2 The theoretical weight of reinforcing steel shall be derived on the basis of sectional weights as per relevant Indian Standards & the lengths for purpose of consumption/reconciliation and payment. No claim shall be entertained from the contractor as such for the difference in theoretical/actual weight of steel during reconciliation or payment for fixing.

C-30.3 Clogging of cement and rusting of steel should be avoided to the maximum extent possible without hampering the continuity of construction/erection. In case due to any cause, attributable to contractor such clogging of cement and/or rusting of steel occurs rendering the same unusable, the contractor shall remain responsible to make good the loss at his own cost.



BHARAT HEAVY ELECTRICALS LTD.,
TRANSMISSION BUSINESS GROUP, New Delhi
Conditions Of Contract For Civil Works, Doc.No.-TB-Civil-GCC, Rev-02

- C-30.4 The contractor shall plan & arrange procurement of steel, cement and other materials as required every month in consultation with the Engineer. Failing compliance to this requirements, further execution of work of the contractor by the BHEL may be suspended and no compensation for delay in the execution of the work or suspension of the works caused on account of the above shall be entertained.
- C-30.5 No materials shall be issued to the contractor except for those specified in Section C-22.0. Contractor shall maintain record of day to day issue and consumption of materials at site like cement, bitumen, lead, paint etc. The contractor will have to make his own arrangements at his own cost for procurement of all materials as required for the works and of such quality as per specification and acceptable to the Engineer.
- C-30.6 In case any additional expenditure is incurred in work arising out of the faulty execution of such work by the contractor, such additional expenditure shall be borne by the contractor.
- C-31.0 **QUALITY ASSURANCE:**
- C-31.1 The contractor has to establish at site the field testing facilities for testing of civil construction materials & concrete cubes and other works as required under the approved Field Quality Plan of BHEL/its customer for ensuring the proper quality, grade and strength of the materials used in the construction. If further test is required by the Engineer to be carried from outside laboratory, the cost of the same shall be borne by contractor (copies of the Field Quality Plan & other Inspection & Test procedures to be followed shall be issued after mobilisation by the sub-contractor).
- C-31.2 The contractor has to arrange for calibration of all test equipment/instruments brought by him as per the requirement of BHEL calibration procedure as directed by the Engineer. The test certificates/calibration certificates shall have to be submitted. BHEL site shall control use of these equipment/instruments by allotting control number and permitting use of only those equipment/ instruments which are under calibrated status.
- C-32.0 **CLEARANCE OF SITE AND REPAIRS:**
- C-32.1 The contractor has to clear the site/area where mechanical and electrical erection work is to be commenced/or in progress. The contractor shall remove construction materials and equipment lying in the vicinity and causing



BHARAT HEAVY ELECTRICALS LTD.,
TRANSMISSION BUSINESS GROUP, New Delhi
Conditions Of Contract For Civil Works, Doc.No.-TB-Civil-GCC, Rev-02

obstruction in the erection work within 24 hours notice. In case, he fails to clear the site, this will be done at his risk and cost by BHEL. For the works executed by the contractor, the deficiencies pointed out must be attended within specified period.

C-33.0 PROTECTION OF WORK:

C-33.1 The contractor shall have total responsibility of protecting his works till it is finally taken over by the Engineer. No claim will be entertained by the Engineer for any damage or loss to the contractor's works and the contractor shall be responsible for the complete restoration of damaged works to its original condition to comply with specifications and drawings. Should any such damage to the contractor's works occur because of other party not under his supervision or control, the contractor shall make his claim directly with the party concerned. The contractor shall not cause any delay in the repair of such damaged works because of any delay in the resolution of such disputes. The contractor shall proceed to repair the work immediately and no cause thereof will be assigned pending resolution of such disputes.

C-34.0 RECORD FOR MATERIALS CONSUMED:

C-34.1 The contractor has to maintain and furnish to the Engineer the record of materials procured and consumed in the works for each activity. The statement showing the theoretical vis-s-vis actual consumption of specified materials, such as structural/reinforcement steel, cement, bitumen, lead, paint etc. shall be enclosed along with the running bills submitted by the contractor. Contractor has to also furnish the test results of the concrete cubes, bricks, stone aggregate and other materials used in work as per IS specifications along with the running bills.

C-35.0 SECURED ADVANCE ;

C-35.1 DELETED

- a)
- b)
- c)
- d)
- e)
- f)



BHARAT HEAVY ELECTRICALS LTD.,
TRANSMISSION BUSINESS GROUP, New Delhi
Conditions Of Contract For Civil Works, Doc.No.-TB-Civil-GCC, Rev-02

C-35.2 DELETED

Above clause No.C-35.0 stands deleted. Please refer Annexure to conditions of contract for civil works



ANNEXURE TO CONDITIONS OF CONTRACT FOR CIVIL WORKS

The following terms and conditions shall form a part of the tender document. If any discrepancies found between below mentioned clauses and clauses in the Conditions of Contract for Civil Works, Doc.No.-TB-Civil-GCC, Rev-02, the clauses mentioned in this annexure shall prevail.

A. Condition of Contract for Civil works (DOC. NO. – TB-Civil-GCC, Rev-02):

A.1. GENERAL INSTRUCTION

A.1.1. All pages of the tender documents shall be duly signed, stamped and submitted along with the offer in token of complete acceptance thereof. The information furnished shall be complete by itself. The tenderer is required to furnish all the details and other documents as required in the following pages.

A.1.2. Tenderers are advised to study all the tender documents carefully. Any submission of tender by the tenderer shall be deemed to have been done after careful study and examination of the tender documents and with the full understanding of the implications thereof. Should the tenderers have any doubt about the meaning of any portion of the Tender Specification or find discrepancies or omissions in the drawings or the tender documents issued are incomplete or shall require clarification on any of the technical aspect, the scope of work etc., tenderer shall at once, contact the authority inviting the tender well in time (so as not to affect last date of submission) for clarification before the submission of the tender. Tenderer's request for clarifications shall be with reference to Sections and Clause numbers given in the tender documents. The specifications and terms and conditions shall be deemed to have been accepted by the tenderer in his offer. Non-compliance with any of the requirements and instructions of the tender enquiry may result in the rejection of the tender.

A.2. PROCEDURE FOR SUBMISSION OF SEALED TENDERS

A.2.1. Bidders may please refer Cl no. 02 to Cl no. 03 of the Notice inviting tender.

A.2.2. The tenders received after the specified time of their submission shall be treated as 'Late Tenders' and shall not be considered under any circumstances.

A.2.3. Tenders shall be opened by the officers concerned of BHEL at the time, date and venue as specified in the tender enquiry. Tenderer or their authorized representative may witness the bid opening.

A.2.4. The tenderer shall closely pursue all the clauses, specifications and drawings indicated in the Tender Documents before quoting. Should the tenderer have any doubt about the meaning of any portion of the Tender Specifications or find discrepancies/omission in the drawings or the tender documents issued are incomplete or shall require clarification on any of the technical aspect, scope of work etc. he shall at once contact the authority inviting the tender for clarification before the submission of the tender.

A.2.5. Before submission of offer, the tenderer is advised to inspect the work & the environments and be well acquainted with the actual working and other prevalent conditions, facilities available, sourcing of material and labour, means of transport and access to site, accommodation, etc. No claim will be entertained later on the grounds of lack of knowledge on any of these conditions/ resources.

A.2.6. Tenderer must fill up all the schedules and furnish all the required information as per the instructions given in various sections of the tender specification. Each and every page of the Tender Specification must be SIGNED AND SUBMITTED ALONG WITH THE OFFER by the Tenderer in token of complete acceptance thereof the information

furnished shall be complete by itself.

A.2.7. The tenderer shall quote the rates in English Language and international numerals. Total price offered should be entered in figures as well as in words. For the purpose of the tender, the metric system of units shall be used.

A.2.8. The tenderer shall quote a percentage above/ below/At Par the rates shown in the "Bill of Quantities Cum Price Schedule (Annexure-I)" of subject tender.

A.2.9. The quoted percentage will apply to the individual items of "Annexure-I i.e. Bill of Quantity Cum Price Schedule" uniformly.

A.2.10. All entries in the tender shall either be typed or be written legibly in ink. Erasing and overwriting are not permitted and may render such tender liable for rejection. All cancellations and insertions shall be duly attested by the tenderer.

A.2.11. The tenderer must provide the registered e-mail of their registered office along with the addresses and authorised phone/mobile nos.

A.3. ADJUSTMENT PRICE DISCREPANCY (IES): - Not Applicable being e procurement.

A.4. EVALUATION OF TECHNICAL BIDS

A.4.1. Technical Bids submitted by the tenderer will be opened first and evaluated for fulfilling the Pre-Qualification criteria and other conditions in NIT/Tender documents, based on documentary evidences submitted along with the offer.

A.4.2. In case the same qualifying experience is claimed by more than one bidder due to subletting of work by main contractor to subcontractor (s) then following conditions shall be applicable.

A.4.2.1. For labour + consumable contract without material and T&P:

Benefit of work experience shall be given to the subcontractor who has actually executed job and not to the contractor offloaded down the line.

A.4.2.2. For contract with complete scope i.e. with materials, T&P, labour and consumable:

- i) Benefit of work experience shall be given to the subcontractor who has actually executed job and not to the contractor offloaded down the line.
- ii) If the contractor offloads the labour and/or T&P portion only, benefit of work experience shall be given to the main contractor and not to the subcontractor who has executed only as labour supply contractor

The bidder's qualification shall be subject to submission of documentary proof. BHEL reserves the right to ask for further proofs including submission of TDS certificates/ for the said job.

A.4.3. In case the qualifying experience is claimed by private organizations based on Work Order and completion certificates from another private organization, BHEL reserves the right to ask for further proofs including submission of TDS certificates/ form 26AS /bills for the said job.

A.4.4. Credentials of all the bidders participating in open tender will be scrutinized thoroughly by the nominated committee w.r.t. the pre-qualifying requirement for the

tender.

A.4.5. Details of qualifying work(s) executed by the bidder will be forwarded to the principle employer for verification of the work with respect to completion, commencement & completion date, scope and value of the work executed. Performance feedback of the bidder will also be sought from the principle employer.

A.4.6. BHEL may conduct onsite verification of at least one of the qualifying works to verify completion of the work and evaluate capability and performance of the bidder.

A.4.7. The bidder representative may be called for the discussion with the committee. His originals may be verified by the committee. In addition to above their organization chart and detailed list of manpower, tools & plants and technical capability may be discussed and ascertained by the committee.

A.5. EVALUATION OF PRICE BIDS

A.5.1. Price Bids of unqualified bidders shall not be opened.

A.5.2. The offers will be evaluated on the basis of total price basis (refer "BILL OF QUANTITY AND PRICE SCHEDULE) as shown in the price bid.

A.5.3. Reasons for rejection of the bid shall be intimated in due course after issue of LOI/LOA to successful bidder and receipt of unconditional acceptance of LOI /LOA from the successful bidder.

A.5.4. In case of electronic Reverse Auction, the unqualified bidders shall not be allowed to participate in reverse auction.

A.6. DOCUMENTS TO BE ENCLOSED:

Full information shall be given by the tenderer in respect of the following.

A.6.1. Tenders shall be signed by persons duly authorized/empowered to do so. An attested copy of the Power of Attorney to be submitted in all cases except where the sole proprietor is the signatory to the tender documents.

A.6.2. PERMANENT ACCOUNT NUMBER:

Certified copies of Permanent Account Numbers as allotted by Income Tax Department for the Company / Firm / Individual Partners, etc. shall be furnished along with tender.

A.6.3. AUDITED BALANCE SHEET AND INCOME TAX RETURN:

Copy of Audited Balance sheets and income tax return for last Five financial years (financial years as specified in PQR).

A.6.4. SOLVENCY CERTIFICATE:

If asked in NIT, bidder should submit solvency certificate (not older than 12 months from date of tender notification) issued by any scheduled bank.

A.6.5. DOCUMENT RELATED TO INCORPORATION OF BUSINESS ENTITY:

A.6.5.1. IN CASE OF INDIVIDUAL TENDERER:

His/her full name, address and place & nature of business.

A.6.5.2. IN CASE OF PARTNERSHIP FIRMS:

The names of all the partners with address. A copy of the partnership deed/instrument of partnership duly certified by the Notary shall be enclosed.

A.6.5.3. IN CASE OF COMPANIES:

Date & place of registration including date of commencement certificate in case of Public Companies and the nature of business carried on by the company. Certified copies of Memorandum and Articles of Association are also to be furnished.

A.6.6. Offer forwarding letter over the letterhead.

A.6.7. *Declaration sheets (As per Prescribed format) over the letter head.*

A.6.8. *No Deviation certificates (As per Prescribed format) over the letterhead.*

A.6.9. GST Registration certificate: -

All the data required to be enclosed with the tender need to be furnished neatly typed, signed & stamped in the given formats only (in the form of separate sheets) failing which the tender may be considered as incomplete and is liable for rejection. Documentary proof wherever necessary also need to be enclosed.

A.7. VALIDITY OF OFFER

The rates in the Tender shall be kept valid for acceptance for a minimum period of **Four Months** from latest due date of offer submission (including extension(s), if any). In case BHEL (Bharat Heavy Electricals Limited) calls for negotiations, such negotiations shall not amount to cancellation or withdrawal of the original offer which shall be binding on the tenderer.

A.8. REJECTION OF TENDER & OTHER CONDITIONS:

A.8.1. The decision of acceptance of tender will rest with BHEL which does not bind itself to accept the lowest tender or any tender and reserves to itself full rights for the following without assigning any reasons whatsoever:

- a) To reject any or all of the tenders.
- b) To split up the work amongst two or more Tenderer as per NIT
- c) To award the work in part as per NIT
- d) In either of the contingencies stated in (b) and (c) above to modify the time for completion suitably.

- A.8.2. Conditional tenders, unsolicited tenders, containing abnormally low/ unworkable rates & amounts, tenders which are incomplete or not in the form specified or defective or have been materially altered or not in accordance with the tender conditions, specifications etc. are liable to be rejected.
- A.8.3. Tenders are liable to be rejected in case of unsatisfactory performance of the tenderer with BHEL, or tenderer under suspension (hold / banning / delisted) by any unit / region / division of BHEL or tenderers who do not comply with the latest guidelines of Ministry / Commissions of Govt. of India. BHEL reserves the right to reject a bidder in case it is observed that they are overloaded and may not be in a position to execute this job as per the required schedule in line with 'NIT'. The decision of BHEL will be final in this regard.
- A.8.4. In case of any adverse information is received concerning performance, capability or conduct of the tenderer after issue of tender enquiry or opening of tender or award of work, BHEL reserves the right to reject the offer at any stage as deemed fit.
- A.8.5. Offers with inadequate Tools & Plants, Manpower Deployment Plan, and Method Statement are liable for rejection.
- A.8.6. If a tenderer who is a proprietor expires after the submission of his tender or after the acceptance of his tender, BHEL may at its discretion, cancel such tender. If a partner of a firm expires after the submission of the tender or after the acceptance of the tender, BHEL may cancel such tender at its discretion unless the firm retains its character.
- A.8.7. BHEL will not be bound by any Power of Attorney granted by the tenderer or by changes in the composition of the firm made subsequent to the execution of the contract. BHEL may, however, recognise such Power of Attorney and changes after obtaining proper legal advice, the cost of which will be chargeable to the contractor concerned.
- A.8.8. If the tenderer deliberately gives wrong information in his tender, BHEL reserves the right to reject such tender at any stage or to cancel the contract, if awarded, and forfeit the Earnest Money/Security Deposit/any other moneys due.
- A.8.9. Canvassing in any form in connection with the tender is strictly prohibited and the tenders submitted by the tenderer who resorts to canvassing are liable to be rejected.
- A.8.10. In case the Proprietor, Partner or Director of the Company / Firm submitting the Tender, has any relative or relation employed in BHEL, the authority inviting tender shall be informed to the fact as per specified format along with the offer, failing this, BHEL may, at its sole discretion reject the tender or cancel the contract and forfeit the Earnest Money/ Security Deposit.
- A.8.11. The successful tenderer should not sub-contract the part or complete work detailed in the tender specifications without written permission of BHEL's Site In charge/ Sector Head. For this the contractor shall submit request application to site in charge supported by credentials (financial and technical) and resource mobilization schedule of such sub-contractor. Such request is to be considered in consultation with end user/ultimate customer (if applicable) and subject to satisfactory credentials, fund flow arrangement between them, HSE and other contractual and statutory

obligations. The tenderer is solely responsible to BHEL for the work awarded to him.

A.8.12. Unsolicited discount received after the due date and time of Bid Submission shall not be considered for evaluation. However, if the party who has submitted the unsolicited discount/rebate becomes the L-1 party, then the awarded price i.e. contract value shall be worked out after considering the discount so offered.

A.8.13. BHEL shall not be liable for any expenses incurred by the bidder in the preparation of the tender irrespective of whether the tender is accepted or not.

A.9. **NO DEVIATIONS ARE ACCEPTABLE: -**

Offers with deviations are likely to be rejected. However, if the bidder insists on any technical or commercial deviations from the specifications and / or tender conditions, **the price implication, if any, of withdrawing the deviations must be submitted along with the price bid in a separate sealed envelope super-scribed "PRICE IMPLICATION FOR WITHDRAWAL OF DEVIATIONS".** No price implication for withdrawal of deviation shall be accepted at a later date, after opening of technical bid.

A.10. Consortium/ JV bidding is not allowed under this NIT.

B. EARNEST MONEY DEPOSIT- NA

C. SECURITY DEPOSIT

Security Deposit means the security provided by the Contractor towards fulfilment of any obligations in terms of the provision of the contract.

C.1. Upon acceptance of Tender, the successful Tenderer should deposit the required amount of Security Deposit for satisfactory completion of work. **The total amount of Security Deposit will be 5% of the Contract Value. EMD of the successful tenderer shall be converted and adjusted towards the required amount of Security Deposit.**

C.2. Mode of Security deposit:

The security Deposit should be furnished **before start of the work** by the contractor.

"Bidders agrees to submit performance security required for execution of the contract within the time period mentioned. In case of delay in submission of Performance security, enhanced performance security which would include interest (Repo rate + 4%) for the delayed period, shall be submitted by the bidder.

Further, if performance security is not submitted till such time the first bill becomes due, the amount of performance security due shall be recovered as per terms defined in NIT / Contract, from the bills along with due interest".

The balance amount to make up the required Security Deposit of 5% of the contract Value may be furnished in any of the following forms:

- i) Cash (as permissible under the extant Income Tax Act)
- ii) Local cheques of scheduled banks (subject to realization) / Pay Order / Demand Draft / Electronic Fund Transfer, in favour of BHEL.
- iii) Bank Guarantee from Scheduled Banks / Public Financial Institutions as defined in the Companies Act. The Bank Guarantee format for Security Deposit shall be in the prescribed formats enclosed with general conditions of contract.

- iv) Fixed Deposit Receipt issued by Scheduled Banks / Public Financial Institutions as defined in the Companies Act. The FDR should be in the name of the contractor, A/C BHEL and duly discharged on the back.
- v) Securities available from Indian Post Offices such as National Savings Certificates, Kisan Vikas Patras etc. (Certificates should be held in the name of Contractor furnishing the security and duly endorsed/hypothecated/pledged, as applicable, in favour of BHEL and duly discharged on the back).
- vi) Insurance Surety Bonds

(NOTE: BHEL will not be liable or responsible in any manner for the collection of interest or renewal of the documents or in any other matter connected therewith)

C.3. Submission of Security Deposit:

- i) At least 50 % of the required Security Deposit, including the EMD, shall be submitted before start of work. Balance of the Security Deposit can be submitted by way of deduction of 10% of the gross amount progressively from each running bills of the contractor till the total amount of the required Security Deposit is collected.
- ii) In case of delay in submission of performance security, enhanced performance security which would include interest (Repo rate + 4%) for the delayed period, shall be submitted by the bidder
- iii) If the value of work done at any time exceeds the contract value, the amount of Security Deposit shall be correspondingly enhanced and the additional Security Deposit shall be immediately deposited by the Contractor or it shall be recovered from payment/s due to the Contractor.
- iv) The recoveries made from running bills (cash deduction towards balance SD amount) can be released against submission of equivalent Bank Guarantee in acceptable form, but only once, before completion of work, at the discretion of BHEL.

C.4. The BG shall be submitted only through the Banker. Along with the BG, the Bank shall also furnish a letter of confirmation (in the prescribed formats enclosed with general conditions of contract).

C.5. The validity of the Bank Guarantee furnished towards Security Deposit shall be up to three months more than the period of completion of work as stipulated in the LOI and the same will be kept valid by proper renewal till the completion of the work.

C.6. BHEL reserves the right of forfeiture of Security Deposit in addition to other claims and penalties in the event of the contractor's failure to fulfil any of the contractual obligations or in the event of termination of contract as per terms and conditions of the contract. BHEL reserves the right to set off the Security Deposit, against any claims of any other contracts with BHEL.

C.7. Conditions for acceptance of bank guarantees

Contractors are advised to obtain Bank Guarantee preferably from any of the following BHEL consortium banks

Sl. No.	Name of Bank	Sl. No.	Name of Bank
1	State Bank of India	11	Punjab National Bank
2	Canara Bank	12	Union Bank of India
3	IDBI Bank Limited	13	Yes Bank Limited
4	ICICI Bank Limited	14	RBL Bank Ltd.
5	HDFC Bank Limited	15	Standard Chartered Bank
6	Axis Bank	16	Indian Overseas Bank
7	IndusInd Bank Limited	17	Kotak Mahindra Bank Limited
8	Bank of Baroda	18	Federal Bank Limited
9	Exim Bank	19	Hongkong and Shanghai Banking Corporation Ltd
10	Indian Bank		

Bank Guarantees from Banks outside BHEL's consortium shall be as below:

The Bank Guarantees of all Public sector banks can be accepted (in addition to consortium banks)

The Bank Guarantees of Co-operative banks shall not be accepted.

Bank Guarantees of other than consortium bank and public sector bank can be accepted subject to an overall exposure limit (at New Delhi) of Rs. 10 crores for banks with net worth of more than Rs. 500 crores as on last balance sheet date and Rs 5 crores for banks with net worth between Rs. 350 to Rs 500 crores (A certificate and copy of latest Balance Sheet to be given by the Bank at the time of submission of Bank Guarantees).

In case of private sector banks, a clause to be incorporated in the text of Bank Guarantee that it can be enforceable by being presented at any branch of the bank.

In case of foreign vendors, the bank guarantees issued by foreign banks may be confirmed by our consortium bank in India.

In case of Bank Guarantees given by Non-Consortium banks (Private sector or Public sector), the Bank Guarantees are to be enforceable in New Delhi or the town/ city in which the sector office is located.

C.8. RETURN OF SECURITY DEPOSIT:

If the contractor duly performs and completes the work in all respects to the entire satisfaction of BHEL and presents an absolute "No demand certificate", returns properties belonging to BHEL, taken, borrowed or hired by him for carrying out the said works, and furnishes performance bond BG in the prescribed proforma, Security Deposit will be released to the contractor after deducting all costs, expenses and other amounts that are to be paid to BHEL under this contract or other contracts entered into with the contractor.

It may be noted that in no case the Security Deposit shall be refunded/released prior to passing of final bill.

D. Bank Account Details for submission of EMD/ Security Deposit through electronic fund transfer mode.

NAME OF THE COMPANY	BHARAT HEAVY ELECTRICALS LTD
ADDRESS OF THE COMPANY	TRANSMISSION BUSINESS GROUP, 5TH FLOOR, BHEL TOWER, PLOT NO. 25, SECTOR-16A, NOIDA – 201301 (U.P.)
NAME OF BANK	STATE BANK OF INDIA
NAME OF BANK BRANCH	CAG-II NEW DELHI (17313)
CITY	NEW DELHI
ACCOUNT NUMBER	00000030206227732
ACCOUNT TYPE	CASH CREDIT
IFSC CODE	SBIN0017313

E. Overall Quantity variation-

The individual quantity can vary to any extent or may be deleted for which no compensation will be payable to the contractor and the rates will remain firm. Also the rate of each item remains firm as long as the variation in the total value of work executed under the contract including extra items (if any) remains within plus/minus 30 percent of the contract value. In case the actual value of executed work including extra work on completion of work becomes less than 70% of the basic/original contract value than the following method shall be adopted.

The actual executed value shall be raised by 7% (For arriving at the final payment against work executed) subject to the condition that total value of work executed plus increase by 7% as above shall be limited to 70% of the basic/original contract value. The rate quoted shall be firm irrespective of any upward variation in the contract price.

It is further clarified that the enhancement/rate revision on the basic rate as per PVC clause shall not be accounted for the purpose of operating this clause.

F. Clause No. C.29.7 “INCOME TAX/SALES TAX/WORKS TAX/VAT” stands deleted. Now this clause shall be read as below.

F.1. All taxes (except GST), duties, charges, royalties, cess and any other levies by Central/ State/local authorities for the execution of the contract shall be borne by the contractor and shall not be payable extra.

Any increase of the same at any stage during execution of the contract shall be borne by the contractor.

Quoted price of the same shall be inclusive of all such requirements.

F.2. GST along with Cess (as applicable) legally leviable & payable by successful bidder as per GST Law shall be paid by BHEL, extra.

Hence, bidder shall not include GST along with Cess (as applicable) in their quoted rates/ price.

F.3. Contractors have to make their own arrangement at their cost for completing the formalities, if required with relevant taxation authorities, for bringing their material, plant and machinery at site for the execution of the contract. Road permits / way bill, if

required shall be arranged by the contractor.

- F.4. Contractor shall furnish proof of GST registration with GSTN Portal covering the services under this contract.

Registration should also bear endorsement for the premises from where the billing shall be done by contractor on BHEL for this project / work

However, in case contractor submits GST Registration of a state other than the state wherein the site is located, then contractor has to submit an undertaking that contractor is not liable to take registration in the state wherein the site is located as per the provision of Place of Supply under CGST/SGST/IGST Act.

BHEL will not be held responsible for any non-compliance of the Contractor in respect of GST laws as framed from time to time.

- F.5. Contractor shall comply with all statutory amendment/notifications in this respect
Contractor shall submit the tax invoice complying with GST Invoice Rules (Section 31 of GST Act & Rules referred thereunder).

In case of raising any Supplementary Tax Invoice (Debit / Credit Note), contractor shall issue the same containing all the details as referred in Section 34 read with Section 31 of GST Act & Rules referred there under.

Contractor shall comply with the Time Limit prescribed under the GST Law and rules thereof for raising the Tax Invoice

- F.6. Goods and Service Tax (GST) will be reimbursed to the Contractor subject to the following conditions: -
- I. Submission of valid GST Compliant Tax Invoice as per the GST Invoice Rules.
 - II. The Invoice raised by the Contractor should indicate the BHEL GST Registration Number.)
 - III. Contractor shall upload the invoices raised on BHEL in IFF/GSTR-1 within the prescribed time as given in the GST Act.
 - IV. Invoice raised and uploaded in IFF/GSTR-1 by the Contractor should be available to BHEL in FORM GSTR-2B electronically through the common portal
 - V. Confirmation of payment of such GST to the Government through filing of GSTR-3B of corresponding month/quarter.

- F.7. The GST amount should get reflected within prescribed time limit in the GSTN for BHEL to avail the input credit. If the GST Credit is reversed/ denied/ delayed to BHEL due to non-receipt/delayed receipt of Services and/or tax invoice or due to expiry of timeline prescribed in GST law or due to any other factor for availing such Input Tax Credit (ITC) or for any other reason arising out of the act directly attributable to the Contractor, GST amount shall be recoverable from Contractor from any dues payable to the Contractor along with any interest levied/ leviable on BHEL.
- F.8. Statutory variation, if any, on account of GST will be payable by BHEL at actuals on submission of documentary evidence.
- F.9. TDS under Income Tax Act/ GST Act shall be deducted as per applicable rates unless Exemption certificate, if applicable, from the appropriate Authority is furnished to BHEL along with the Invoice.

F.10. New Taxes & duties (Introduced after tender opening date):

If any new tax or duty is levied by the Central/State Government/Municipality/Local Authority and becomes directly applicable on items specified in the Bill of Quantities, full reimbursement shall be made subject to submission of documentation as per statute.

G. Clause C-27.0 of “Over run charges” under special conditions of contract is now deleted. No overrun charges are payable under the contract.

H. Clause C-35.0 “secured advance” under special conditions of contract is now deleted. No advance on materials shall be payable under the contract.

I. Clause C-26.0 “Price Variation” under special conditions of contract is now deleted. Price variation clause is not applicable for this contract.

J. Issue of Material by BHEL: NA

K. RESPONSIBILITY OF CONTRACTOR IN RESPECT OF STATUTORY RULES / REGULATIONS PERTAINING TO BOCW.

It shall be mandatory for the contractor to comply with Building and Other Construction Worker (Regulation of Employment and Conditions of Service) Act, 1996 and Rules of 1998 read with Building and other Construction Workers welfare Cess act, 1996 and Cess Rules.

It shall be the sole responsibility of the contractor to apply for a license to the Competent Authority under the Building and Other Construction Worker (Regulation of Employment and Conditions of Service) Act, 1996 and Rules of 1998 read with Building and other Construction Workers welfare Cess act, 1996 and Cess Rules and obtain proper certificate thereof by specifying the scope of its work. It shall also be responsibility of the contractor to furnish a copy of such certificate of license / permission to BHEL within 2 months from date of start of work at site or along with 1st RA bill whichever is earlier.

It shall be the responsibility of the sub-contractor to furnish the receipts / challans towards deposit of the cess together with the number, name and other details of beneficiaries (building or construction workers) engaged by the sub-contractor during the preceding month.

The onus shall lie on the contractor to register with the authorities and provide the details of the amount remitted to the authorities. In case the contractor fails to comply with the BOCW act, no payments shall be released to the contractor.

In case the customer owns the responsibility of compliance of BOCW act and deducts the amount from BHEL, the same shall be deducted from the RA bills of the contractor.

In the event of any penalty or other implication due to non-compliance of statutory obligation the same shall be on contractor’s account.

L. Clause No. C.24.0 (Delay and Extension of Time) of Conditions of Contract for Civil Works has been modified as below

If, in the opinion of the Engineer, the work is delayed

- (i) by reason of abnormally bad weather, or

- (ii) by reason of serious loss or damage by fire, or
- (iii) by reason of civil commotion, local combination of workmen, strike or lockout, affecting any of the trades employed on the work, or
- (iv) by delay on the part of the agency or tradesman engaged by the BHEL in executing work not forming part of the contract, or
- (v) By reason of any other cause which in the absolute discretion of the Engineer is beyond the contractor's control, then in any such case, the Engineer (or higher authority) may make fair and reasonable extension in the completion dates of the individual items of work of the contract as whole. Such extension which will be communicated to the contractor by the Engineer in writing shall be final and binding on the contractor. No other claim in this respect for compensation, idle labour or otherwise howsoever is admissible. Upon the happening of any such event causing delay the contractor shall immediately give notice thereof in writing to the Engineer but shall nevertheless use constantly his best endeavour to prevent or make good the delay and shall do all that may reasonably be required to the satisfaction of the Engineer to proceed with the work.
- (vi) In case of delay in completion of work BHEL reserve the right to grant time extension under the following options depending upon the performance of the vendor:
 - a) Time extension without levy of LD in case it is found that delay is not attributable to the vendor
 - b) Time extension with deduction of applicable LD in line with Liquidity Damage clause if the delay is solely attributable to the vendor.
 - c) In case facts of delay is not settled, BHEL reserve the right to grant provisional time extension for delay in completion of total work or part thereof and running/ interim payments to the vendor will be released without deduction of LD subject to submission of additional Bank guarantee equivalent to maximum LD amount valid till completion of work under their scope and grant of final time extension.

During provisional time extension period ORC/ PVC shall not be payable to the contractor. The Final Delay analysis shall be prepared on completion of the work. In case of delay is not attributable to contractor as per final delay analysis the ORC/ PVC shall be released along with the final bill without any interest charges attributable to BHEL.

In case of delay attributable to contractor, LD shall be deducted for that period in line with clause "Compensation/ LD/ Penalty for delay in execution" of conditions of contract and balance ORC/ PVC (if any) shall be released along with the final bill without any interest charges attributable to BHEL.

M. LD / PENALTY FOR DELAY IN EXECUTION:

Liquidated Damages, wherever referred under this Tender/Agreement, shall mean and refer to the damages, not in the nature of penalty, which the contractor agrees to pay in the event of delay in delivery of stores, installation, commissioning, breach of contract etc. as the case may be.

Liquidated Damages leviable upon the contractor is a sum which is agreed by the parties as a reasonable and genuine pre-estimate of damages which will be suffered by BHEL on account of delay/breach on the part of the contractor.

Liquidated Damages shall be calculated in the manner stipulated hereinafter:

In case the work is not completed within the stipulated time period, BHEL at its discretion may grant provisional time extension to contractor for the sole purpose of completion of balance works keeping its right reserved under the contract and law.

Grant of any provisional time extension shall by no means be considered as waiver of BHEL rights under the contract or law.

After the completion of work, duly certified by Engineer In charge, a comprehensive delay analysis shall be carried out to ascertain the attribution of delays in the provisional time extensions granted to contractor. The delay analysis shall record:

- a) Delays solely attributable to contractor
- b) Delays attributable to BHEL
- c) Delays on account of Force Majeure (as specified elsewhere in the contract)

The total period under the final time extension shall be equal to the period between the scheduled date of completion and the actual date of completion of contract. LD shall be imposed/ levied for the portion of time extensions solely attributable to contractor and recoverable from the dues payable to the contractor.

For the periods, wherein the delay as per the comprehensive delay analysis carried out is solely attributable to contractor, BHEL shall have the right to impose Liquidated Damage at the rate of 0.5% of the contract value, per week of delay or part thereof subject to a maximum of 10% of the contract value.

Contract Value for this purpose, shall be the final executed value exclusive of ORC, Extra Works executed on Man-day rate basis, Supplementary/ Additional Items and PVC. Before levying LD, the contractor shall be duly intimated the amount and reasons thereof for imposition of LD.

N. RIGHTS OF BHEL: - The Clause No. B.7.0 "RIGHTS of BHEL" of Conditions of contract for Civil works stands deleted. Now the modified clause shall be read as below: -

BHEL reserves the following rights in respect of this contract during the original contract period or its extensions if any, as per the provisions of the contract, without entitling the contractor for any compensation.

1. To withdraw any portion of work and/or to restrict/alter quantum of work as indicated in the contract during the progress of work and get it done through other agencies to suit BHEL's commitment to its customer or in case BHEL decides to advance the date of completion due to other emergent reasons/ BHEL's obligation to its customer.
In case of inadequate manpower deployed by the contractor, BHEL reserves the right to deploy additional manpower through any other agency for expediting activities in the interest of the project.
Supplied manpower shall be put on job by the contractor and payments and other statutory compliances related to manpower shall be the contractor's responsibility. In case of contractor's failure to fulfill his obligations in respect of such manpower, BHEL reserves the right to take necessary action as per contract conditions.

2. Breach of Contract, Remedies and Termination

2.1. The following shall amount to breach of contract:

- I. Non-supply of material/ non-completion of work by the Supplier/Vendor within scheduled delivery/ completion period as per contract or as extended from time to time.
- II. The Supplier/Vendor fails to perform as per the activity schedule and there are sufficient reasons even before expiry of the delivery/ completion period to justify that supplies shall be inordinately delayed beyond contractual delivery/ completion period.
- III. The Supplier/Vendor delivers equipment/ material not of the contracted quality.
- IV. The Supplier/Vendor fails to replace the defective equipment/ material/ component as per guarantee clause.
- V. Withdrawal from or abandonment of the work by the Supplier/Vendor before completion as per contract.
- VI. Assignment, transfer, subletting of Contract by the Supplier/Vendor without BHEL's written permission resulting in termination of Contract or part thereof by BHEL.
- VII. Non-compliance to any contractual condition or any other default attributable to Supplier/Vendor.
- VIII. Any other reason(s) attributable to Vendor towards failure of performance of contract. In case of breach of contract, BHEL shall have the right to terminate the Purchase Order/ Contract either in whole or in part thereof without any compensation to the Supplier/Vendor.
- IX. Any of the declarations furnished by the contractor at the time of bidding and/ or entering into the contract for supply are found untruthful and such declarations were of a nature that could have resulted in non-award of contract to the contractor or could expose BHEL and/ or Owner to adverse consequences, financial or otherwise.
- X. Supplier/Vendor is convicted of any offence involving corrupt business practices, antinational activities or any such offence that compromises the business ethics of BHEL, in violation of the Integrity Pact entered into with BHEL has the potential to harm the overall business of BHEL/ Owner.

Note- Once BHEL considers that a breach of contract has occurred on the part of Supplier/Vendor, BHEL shall notify the Supplier/Vendor by way of notice in this regard. Contractor shall be given an opportunity to rectify the reasons causing the breach of contract within a period of 14 days.

In case the contractor fails to remedy the breach, as mentioned in the notice, to the satisfaction of BHEL, BHEL shall have the right to take recourse to any of the remedial actions available to it under the relevant provisions of contract.

LD against delay in executed work in case of Termination of Contract:

LD against delay in executed work shall be calculated in line with relevant LD clause of GCC, for the delay attributable to contractor. For limiting the maximum value of LD, contract value shall be taken as Executed Value of work till termination of contract.

Method for calculation of "LD against delay in executed work in case of termination of contract" is given below.

- i) Let the time period from scheduled date of start of work till termination of contract excluding the period of Hold (if any) not attributable to contractor = T1
- ii) Let the value of executed work till the time of termination of contract= X
- iii) Let the Total Executable Value of work for which inputs/fronts were made available to contractor and were planned for execution till termination of contract = Y
- v) Delay in executed work attributable to contractor i.e. $T2=[1-(X/Y)] \times T1$
- vi) LD shall be calculated in line with **LIQUIDATED DAMAGES/PENALTY** clause of the Contract for the delay attributable to contractor taking "X" as Contract Value and "T2" as period of delay attributable to contractor.

2.2 Remedies in case of Breach of Contract is established:

- i) Wherein the period as stipulated in the notice issued under clause "**BREACH OF CONTRACT, REMEDIES AND TERMINATION**" of GCC has expired and Contractor has failed to remedy the breach, BHEL will have the right to terminate the contract on the ground of "Breach of Contract" without any further notice to contractor.
- ii) Upon termination of contract, BHEL shall be entitled to recover an amount equivalent to 10% of the Contract Value for the damages on account of breach of contract committed by the Contractor. This amount shall be recovered by way of encashing the security instruments like performance bank guarantee etc available with BHEL against the said contract. In case the value of the security instruments available is less than 10% of the contract value, the balance amount shall be recovered from other financial remedies (i.e. available bills of the contractor, retention amount, from the money due to the Contractor etc. with BHEL) or the other legal remedies shall be pursued.
- iii) wherever the value of security instruments like performance bank guarantee available with BHEL against the said contract is 10% of the contract value or more, such security instruments to the extent of 10% contract value will be encashed. In case no security instruments are available or the value of the security instruments available is less than 10% of the contract value, the 10% of the contract value or the balance amount, as the case may be, will be recovered in all or any of the following manners:
- iv) In case the amount recovered under sub clause (a) above is not sufficient to fulfil the amount recoverable then; a demand notice to deposit the balance amount within 30 days shall be issued to Contractor.
- v) If Contractor fails to deposit the balance amount within the period as prescribed in demand notice, following action shall be taken for recovery of the balance amount:
 - a. from dues available in the form of Bills payable to defaulted Contractor against the same contract.
 - b. If it is not possible to recover the dues available from the same contract or dues are insufficient to meet the recoverable amount, balance amount shall be recovered from any money(s) payable to Contractor under any contract with other Units of BHEL including

recovery from security deposits or any other deposit available in the form of security instruments of any kind against Security deposit or EMD.

- c. In-case recoveries are not possible with any of the above available options, Legal action shall be initiated for recovery against defaulted Contractor.
- vi) It is an agreed term of contract that this amount shall be a genuine pre-estimate of damages that BHEL would incur in completion of balance contractual obligation of the contract through any other agency and BHEL will not be required to furnish any other evidence to the Contractor for the purpose of estimation of damages.
- vii) In addition to the above, imposition of liquidated damages, debarment, termination, de-scoping, short-closure, etc., shall be applied as per provisions of the contract.

Note:

- 1) The defaulting contractor shall not be eligible for participation in any of the future enquiries floated by BHEL to complete the balance work. The defaulting contractor shall mean and include:
 - (a) In case defaulted contractor is the Sole Proprietorship Firm, any Sole Proprietorship Firm owned by same Sole Proprietor.
 - (b) In case defaulted contractor is The Partnership Firm, any firm comprising of same partners/ some of the same partners (but not including any new partner); or sole proprietorship firm owned by any partner(s) as a sole proprietor.
- 3. In case Contractor fails to deploy the resources as per requirement informed by BHEL in writing to expedite the work, BHEL can deploy own/hired/otherwise arranged resources and recover the expenses incurred from the dues payable to contractor. Recoveries shall be actual expenses incurred plus 5% overheads or as defined in TCC.
- 4. To terminate the contract or to restrict the quantum of work and pay for the portion of work executed in case BHEL's contract with their customer are terminated for any reason, whatsoever.
- 5. Whenever any Claim or Claims for payment of any sum of money(s) arises under this or any other contract against the contractor, BHEL shall be entitled to withhold and also have a lien to retain such sum of money(s) in whole or in part from any money(s) payable to contractor and/or security deposits furnished or deducted in cash from the bills of contractor, (if any) under this contract. In the event of the securities or the amounts payable to Contractor, being insufficient to cover BHEL claims, then BHEL shall be entitled to withhold and have a lien to the extent of such claims from any sum or sums found payable or which at any time thereafter may become payable to the contractor under this or any other contract with BHEL.
 - a) Claim or Claims for payment of any sum of money(s) arising from the Contractor under this or any other contract against the contractor, shall mean, the sum of money(s) actually incurred by BHEL in fulfilling the contractual responsibilities of contractor under the contract, to which he has failed to fulfil plus applicable overheads (@ 5%) along with interest as applicable under the Contract on total amount (i.e. money actually incurred plus overheads)
 - b) It is an agreed term of the contract that, the sum or sums of money so withheld or retained under the lien by BHEL will be kept withheld or retained as such by BHEL till the claims arising out of this or any other contract are finally adjudicated wither through Arbitration or a Court of competent jurisdiction as the case may be in accordance with the terms of contract. Intimation given by the BHEL Engineer regarding withholding of such money(s) shall be considered as sufficient and relevant date for all purposes. No

Interest shall be payable on such sum(s) of money which becomes due or as the case may be adjudged to be due from BHEL to Contractor, whether under contract or otherwise.

- c) Where the contractor is a partnership firm, BHEL shall be entitled to withhold and also have a lien to retain towards such claims in whole or in part, from any other money(s) payable to any partner, whether in his individual capacity or otherwise.
 - d) If any money(s) shall, as a result of any claim or application made under the relevant provisions of any Labour Welfare Act and/ or Rules, including but not limited to Contract Labour Regulation & Abolition Act, Minimum Wages Act, Payment of Gratuity Act, BOCW (RE&CS) Act, Provident Fund Act, Employee State Insurance Act, be directed to be paid by the BHEL, such money shall be deemed to be moneys payable to the BHEL by the Contractor.
 - e) Where the Contractor fails to repay to BHEL such moneys along with applicable overheads (@ 5%) and interest, as aforesaid within seven days of being demanded, BHEL shall be entitled to recover the same from Contractor's bills/ Security Deposit or any other money(s) payable to Contractor under this Contract or any other Contract with BHEL.
6. While every endeavor will be made by BHEL to this end, yet BHEL cannot guarantee uninterrupted work due to conditions beyond its control. The Contractor will not be normally entitled for any compensation/extra payment on this account unless otherwise specified elsewhere in the contract.
7. BHEL may permit or direct contractor to demobilize and remobilize at a future date as intimated by BHEL in case of following situations for reasons other than Force majeure conditions and not attributable to contractor:
- i) suspension of work(s) at a Project either by BHEL or Customer,
or
 - ii) where work comes to a complete halt or reaches a stage wherein worthwhile works cannot be executed and there is no possibility of commencement of work for a period of not less than three months

In such cases, charges towards demobilization and remobilization shall be as decided by BHEL after successful remobilization by contractor at site, and decision of BHEL shall be final and binding on the contractor. After remobilization, all conditions as per contract shall become applicable. In case Contractor does not remobilize with adequate resources or does not start the work within the period as intimated, then BHEL reserves the right to terminate the contract and effect remedies under Clause "**Remedies in case of Breach of Contract**" In case of any conflict, BHEL decision in this regard shall be final and binding on the contractor.

8. In the unforeseen event of inordinate delay in receipt of materials, drawings, fronts etc. due to which inordinate discontinuity of work is anticipated, BHEL on its own or contractor's request at its discretion may consider to short close the contract in any of the following cases:
- a) The balance works (including but not limited to Trial Operation, PG Test etc.) are minor vis a vis the scope of work envisaged as per the contract.
 - b) There has been no significant work in past 6 months OR no significant work is expected in next 6 months (example in Hydro projects or in projects where work has stopped due to reasons beyond the control of BHEL).

- c) The balance works cannot be done within a reasonable period of time as they are dependent on unit shut down or on other facilities of customer or any other such reasons not attributable to the contractor.

At the point of requesting for short closure, contractor shall establish that he has completed all works possible of completion and he is not able to proceed with the balance works due to constraints beyond his control. In such a case, the estimated value of the unexecuted portion of work (or estimated value of services to be provided for carrying out milestone/stage payments like Trial Operation/PG Test etc.) as decided by BHEL, shall however be reduced from the final contract value.

Note: The Contractor shall not be eligible for any compensation on account of Quantity Variation arising out of short-closure of contract as per clause above.

O. PERFORMANCE MONITORING:

The Contractors performance shall be continuously monitored during execution of work at site.

In case of contractor's performance is found not satisfactory during the execution of work at site, BHEL may take alternate remedial measures and may not consider the contractor for further tenders, if the contractor performance is not improved in spite of opportunities given by BHEL.

P. FACILITIES PROVIDED TO MSEs

Vide office memorandum F.No.21(8)/2011-MA dated 09.11.2016, Office of AS&DC, Ministry of MSME has issued clarification regarding definition of Goods and Services under the Public Procurement Policy of MSEs order-2012, In accordance with the Public Procurement Policy for MSEs order-2012 and OM regarding definition of Goods and Services issued by Ministry of MSME, it is clarified that benefits as envisaged in Public Procurement Policy for MSEs Order 2012 are to be provided in respect of the procurements related to the Goods and Services produced and provided by Micro and Small Enterprises (MSEs) only and **no benefits is to be given in Case of Works Contracts.**

Q. BOCW (TAXES, DUTIES & LEVIES):

S.1	BUILDING & OTHER CONSTRUCTION WORKERS (REGULATION OF EMPLOYMENT AND CONDITIONS OF SERVICE) ACT, 1996 (BOCW Act) AND RULES OF 1998 READ WITH BUILDING & OTHER CONSTRUCTION WORKERS CESS Act, 1996 & CESS RULES, 1998.
	In case any portion of work involves execution through building or construction workers, then compliance to the above titled Acts shall be ensured by the contractor and contractor shall obtain license and deposit the cess under the Act. In the circumstances it may be ensured as under: -
S.1.1	It shall be the sole responsibility of the contractor in the capacity of employer to forthwith (within a period of 15 days from the award of work) apply for a licence to the Competent Authority under the BOCW Act and obtain proper certificate thereof by specifying the scope of its work. It shall also be responsibility of the contractor to furnish a copy of such certificate of licence / permission to BHEL within a period of one month from the date of award of contract.

S.1.2	It shall be the sole responsibility of the contractor as employer to ensure compliance of all the statutory obligations under these act and rules including that of payment / deposit of 1% cess on gross payment made for value of work involving building or construction workers engaged by the contractor within a period of one month from the receipt of payment.
S.1.3	It shall be the responsibility of the sub-contractor to furnish the receipts / challans towards deposit of the cess together with the number, name and other details of beneficiaries (building workers) engaged by the sub-contractor during the preceding month.
S.1.4	It shall be the absolute responsibility of the sub-contractor to make payment of all statutory payments & compensations to its workers including that is provided under the Workmen's Compensation Act, 1923.
S.1.5	The contractor shall, however ensure before deposit of any BOCW cess, that customer is not depositing the same in order to avoid excess deposit of cess.
S.1.6	The contractor shall bear cost of BOCW cess either by way of deposit or through recovery by BHEL in case the same is deposited by the customer.
S.1.7	In case of failure in above mentioned compliances, BOCW Cess @ 1% as well as applicable penalty as specified in BOCW Act/Rules shall be deducted from the contractor.
S.1.8	NOTE: Any labour law or statutory compliance enacted or brought into force by the applicable government during the term of this contract shall be deemed applicable to this contract.

R. TERMS OF PAYMENT:

- R.1. The contractor shall be paid monthly running bill to a maximum of **95% (retaining 5% from each running bill)** of value of the works actually executed on site provided the work has been executed to the satisfaction of the Engineer. From payable amount recoveries such as security deposit, income tax etc. would be made as per rule. The certificate of the Engineer regarding such approval and passing of sums so payable shall be final and conclusive against the contractor.
- R.2. The Engineer shall after a measured bill allow and certify payment to the contractor on the basis of abstract measurement bill submitted by contractor. However, the usual recoveries would be effected from bill.
- R.3. Any certificate relating to the work done may be modified by any subsequent interim certificates or by the final certificate and no certificate of the Engineer supporting an advance payment shall of itself be conclusive evidence that any work or materials to which it relates are in accordance with the contract.
- R.4. All intermediate payments shall be regarded as advance against the final payment only and shall not be considered as an admission of the due performance of the contract or any part thereof in any respect of the occurring of any claim whatsoever. Such intermediate payments shall not conclude, determine or effect in any way the powers of the Engineer as to the final settlement and adjustment of the account of otherwise, or in any way vary of affect the contract. To this affect the contractor shall submit the final bill, which shall contain the complete up-to-date measurements for the total work done.
- R.5. The conditions for the release of **last 5% retention money** shall be as follows:
- R.5.1. 2.5% payment shall be released along with the final bill on completion of total work as certified by BHEL site.

R.5.2. Balance 2.5% of payment shall be released on completion of guarantee period. However, this retention money can be released on submission of B.G. of equivalent amount valid till guarantee period.

R.6. The contractor shall guarantee the work under the scope of the contract for a period of 12 months from the date of start of the guarantee period as certified by BHEL site (i.e. completion of total work under the scope and or taking over by BHEL/owner), and shall rectify free of cost all defects due to faculty supply or work done. In case the contractor fails to repair/ replace the defective work within the time specified by BHEL, BHEL may proceed to undertake such repair/replace such defective work at contract's risk and cost without prejudice to any other right and recover the sum from security deposit/BG/ any dues.

S. MEASUREMENT OF WORK AND MODE OF PAYMENT:

- S.1. All payments due to the contractors shall be made by e mode only, unless otherwise found operationally difficult for reasons to be recorded in writing.
- S.2. For progress running bill payments: - The Contractor shall present detailed measurement sheets in triplicate, duly indicating all relevant details based on technical documents and connected drawings for work done during the month/period under various categories in line with terms of payment as per contract. The basis of arriving at the quantities, weights shall be relevant documents and drawings released by BHEL. These measurement sheets shall be prepared jointly with BHEL Engineers and signed by both the parties.
- S.3. These measurement sheets will be checked by BHEL Engineer and quantities and percentage eligible for payment under various groups shall be decided by BHEL Engineer. The abstract of quantities and percentage so arrived at based on the terms of payment shall be entered in Measurement Book by BHEL Engineers and signed by both the parties.
- S.4. These measurement sheets will be checked by BHEL Engineer and quantities and percentage eligible for payment under various groups shall be decided by BHEL Engineer. The abstract of quantities and percentage so arrived at based on the terms of payment shall be entered in Measurement Book and signed by both the parties.
- S.5. Based on the above quantities, contractor shall prepare the bills, along with statutory documents, in prescribed format and work out the financial value. These will be entered in Measurement Book and signed by both the parties. Payment shall be made by BHEL after effecting the recoveries due from the contractor.
- S.6. All recoveries due from the contractor for the month/period shall be effected in full from the corresponding running bills unless specific approval from the competent authorities is obtained to the contrary.
- S.7. Measurement shall be restricted to that portion of work for which it is required to ascertain the financial liability of BHEL under this contract.
- S.8. The measurement shall be taken jointly by persons duly authorized on the part of BHEL and by the Contractor.
- S.9. The Contractor shall bear the expenditure involved if any, in making the measurements and testing of materials to be used/ used in the work. The contractor shall, without extra charges, provide all the assistance with appliances and other things necessary for measurement.
- S.10. If at any time due to any reason whatsoever, it becomes necessary to re-measure the work done in full or in part, the expenses towards such re measurements shall be borne by the contractor unless such re measurements are warranted solely for reasons not attributable to contractor.
- S.11. Passing of bills covered by such measurements does not amount to acceptance of the completion of the work measured. Any left out work has to be completed, if pointed out at a later date by BHEL.
- S.12. Final measurement bill shall be prepared in the final bill format prescribed for the purpose based on the certificate issued by BHEL Engineer that entire works as stipulated in tender specification has been completed in all respects to the entire satisfaction of BHEL. Contractor shall give unqualified "No Claim" Certificate. All the tools and tackles loaned to him should be

returned in satisfactory condition to BHEL. The abstract of final quantities and financial values shall also be entered in the Measurement Books and signed by both parties to the contract. The Final Bill shall be prepared and paid within a reasonable time after completion of work.

T. NO INTEREST PAYABLE TO CONTRACTOR:

Notwithstanding anything to the contrary contained in any other document comprising in the Contract, no interest shall be payable by BHEL to Contractor on any moneys or balances including but not limited to the Security Deposit, EMD, Retention Money, RA Bills or the Final Bill, or any amount withheld and/or appropriated by BHEL etc., which becomes or as the case may be, is adjudged to be due from BHEL to Contractor whether under the Contract or otherwise.

U. CLOSING OF CONTRACTS

The Contract shall be considered completed and closed upon completion of contractual obligations and settlement of Final Bill or completion of Guarantee period whichever is later. Upon closing of Contract, BHEL shall issue a performance/ experience certificate as per standard format, based on specific request of Contractor as per extant BHEL guidelines through the online portal available at <https://siddhi.bhel.in> only.

V. SUSPENSION OF BUSINESS DEALINGS

BHEL reserves the right to take action against Contractors who either fail to perform or Tenderers/Contractor who indulge in malpractices, by suspending business dealings with them in line with BHEL guidelines issued from time to time.

The offers of the bidders who are under suspension as also the offers of the bidders, who engage the services of the banned firms / principal / agents, shall be rejected. The list of banned firms is available on BHEL web site www.bhel.com.

If any bidder / supplier / contractor during pre-tendering / tendering / post tendering / award / execution / post-execution stage indulges in any act, including but not limited to, malpractices, cheating, bribery, fraud or and other misconduct or formation of cartel so as to influence the bidding process or influence the price or tampers the tendering process or acts or omits in any manner which tantamount to an offence punishable under any provision of the Indian Penal Code, 1860 or any other law in force in India, or does anything which is actionable under the Guidelines for Suspension of Business dealings, action may be taken against such bidder / supplier / contractor as per extant guidelines of the company available on www.bhel.com and / or under applicable legal provisions. Guidelines for suspension of business dealings is available in the webpage:

http://www.bhel.com/vender_registration/vender.php.

W. SETTLEMENT OF DISPUTE

If any dispute or difference of any kind whatsoever shall arise between BHEL and the Supplier/Vendor, arising out of the contract for the performance of the work whether during the progress of contract termination, abandonment or breach of the contract, it shall in the first place referred to Designated Engineer for amicable resolution by the parties. Designated Engineer (to be nominated by BHEL for settlement of disputes arising out of the contract) who within 60 days after being requested shall give written notice of his decision to the contractor. Save as hereinafter provided, such decision in respect of every matter so referred shall forthwith be given effect to by the Supplier/Vendor who shall proceed with the work with all due diligence, whether he or BHEL desires to resolve the dispute as hereinafter provided or not.

If after the Designated Engineer has given written notice of this decision to the party and no intention to pursue the dispute has been communicated to him by the affected party within 30 days from the receipt of such notice, the said decision shall become final and binding on the parties. In the event the Supplier/Vendor being dissatisfied with any such decision or if amicable settlement cannot be reached then all such disputed issues shall be resolved through **conciliation in terms of the BHEL Conciliation Scheme 2018** as per Clause "Conciliation" of GCC.

W.1. Conciliation:

Any dispute, difference or controversy of whatever nature howsoever arising under or out of or in relation to this Agreement (including its interpretation) between the Parties, and so notified in writing by either Party to the other Party (the "Dispute") shall, in the first instance, be attempted to be resolved amicably in accordance with the conciliation procedure as per BHEL Conciliation Scheme 2018. The proceedings of Conciliation shall broadly be governed by Part-III of the Arbitration and Conciliation Act 1996 or any statutory modification thereof and as provided in - "Procedure for conduct of conciliation proceedings" (as available in www.bhel.com)).

Note: Ministry of Finance has issued OM reference No. 1/2/24 dated 03.06.2024 regarding "Guidelines for Arbitration and Mediation in Contracts of Domestic Public Procurement. In the said OM it has been recommended that Government departments/ Entities/agencies are to encourage mediation under the Mediation Act. 2023 . The said Act has not yet been notified by the Government. Therefore, the clause "**Settlement of Disputes**" shall be modified accordingly as and when the Mediation Act 2023 gets notified.

W.2. ARBITRATION:

- W.2.1. Except as provided elsewhere in this Contract, in case Parties are unable to reach amicable settlement (whether by Conciliation to be conducted as provided in Clause "**Conciliation**" herein above or otherwise) in respect of any dispute or difference; arising out of the formation, breach, termination, validity or execution of the Contract; or, the respective rights and liabilities of the Parties; or, in relation to interpretation of any provision of the Contract; or, in any manner touching upon the Contract (hereinafter referred to as the 'Dispute'), then, either Party may, refer the disputes to Arbitral Institution i.e. "**India International Arbitration Centre (IIAC) Delhi**" and such dispute to be adjudicated by Sole Arbitrator appointed in accordance with the Rules of said Arbitral Institution.
- W.2.2. A party willing to commence arbitration proceeding shall invoke Arbitration Clause by giving notice to the other party in terms of section 21 of the Arbitration & Conciliation Act, 1996 (hereinafter referred to as the 'Notice') before referring the matter to arbitral institution. The Notice shall be addressed to the **Executive Director, TBG, BHEL, Noida**, executing the Contract and shall contain the particulars of all claims to be referred to arbitration with sufficient detail and shall also indicate the monetary amount of such claim including interest, if any.
- W.2.3. After expiry of 30 days from the date of receipt of aforesaid notice, the party invoking the Arbitration shall submit that dispute to the Arbitral Institutions and that dispute shall be adjudicated in accordance with their respective Arbitration Rules. The matter shall be adjudicated by a Sole Arbitrator who shall necessarily be a Retd Judge having considerable experience in commercial matters to be appointed/nominated by the respective institution. The cost/expenses pertaining to the said Arbitration shall also be governed in accordance with the Rules of the respective Arbitral Institution. The decision of the party invoking the Arbitration for reference of dispute to a specific Arbitral institution for adjudication of that dispute shall be final and binding on both the parties and shall not be subject to any change thereafter. The institution once selected at the time of invocation of dispute shall remain unchanged.
- W.2.4. The fee and expenses shall be borne by the parties as per the Arbitral Institutional rules.

- W.2.5. The Arbitration proceedings shall be in English language and the seat and venue of Arbitration shall be **Delhi**.
- W.2.6. Subject to the above, the provisions of Arbitration & Conciliation Act 1996 and any amendment thereof shall be applicable. All matters relating to this Contract and arising out of invocation of Arbitration clause are subject to the exclusive jurisdiction of the Court(s) situated at **Delhi**.
- W.2.7. Notwithstanding any reference to the Designated Engineer or Conciliation or Arbitration herein, a. the parties shall continue to perform their respective obligations under the Contract unless they otherwise agree. Settlement of Dispute clause cannot be invoked by the Contractor, if the Contract has been mutually closed or 'No Demand Certificate' has been furnished by the Contractor or any Settlement Agreement has been signed between the Employer and the Contractor.
- W.2.8. The Mechanism of resolution of disputes through arbitration shall be available only in the cases where the value of the dispute is less than Rs. 10 Crores.
- W.2.9. In case the disputed amount (Claim, Counter claim including interest is Rs. 10 crores and above, the parties shall be within their rights to take recourse to remedies other than Arbitration, as may be available to them under the applicable laws after prior intimation to the other party. Subject to the aforesaid conditions, provisions of the Arbitration and Conciliation Act, 1996 and any statutory modifications or re-enactment thereof as amended from time to time, shall apply to the arbitration proceedings under this clause.
- W.2.10. In case, multiple arbitrations are invoked (whether sub-judice or arbitral award passed) by any party to under this contract, then the cumulative value of claims (including interest claimed or awarded) in all such arbitrations shall be taken in account while arriving at the total claim in dispute for the subject contract for the purpose of clause X.2.9. Disputes having cumulative value of less than 10 crores shall be resolved through arbitration and any additional dispute shall be adjudicated by the court of competent jurisdiction.

In case of Contract with Public Sector Enterprise (PSE) or a Government Department, the following shall be applicable:

In the event of any dispute or difference relating to the interpretation and application of the provisions of commercial contract(s) between Central Public Sector Enterprises (CPSEs)/ Port Trusts inter se and also between CPSEs and Government Departments/Organizations (excluding disputes concerning Railways, Income Tax, Customs & Excise Departments), such dispute or difference shall be taken up by either party for resolution through AMRCD (Administrative Mechanism for Resolution of CPSEs Disputes) as mentioned in DPE OM No. 05/0003/2019-FTS-10937 dated 14-12-2022 as amended from time to time.

X. PROGRESSIVE PAYMENT/ FINAL PAYMENT:

X.1. Running Account Bills (RA Bills)

- i) These are for interim payments when the contracts are in progress. The bills for such interim payments are to be prepared by Contractor in prescribed formats (RA Bill forms).
- ii) Payments shall be made according to the extent of work done as per measurements taken up to the end of the calendar month and in line with the terms of payments described in the Tender documents.
- iii) Recoveries on account of electricity, water, statutory deductions etc. are made as per terms of contract.
- iv) Full rates for the work done shall be allowed only if the quantum of work has been done as per the specifications stipulated in the contract. If the work is not executed as per the stipulated specifications, BHEL may ask the contractor to redo the work according to the required specifications, without any extra cost.

- v) The contractor shall submit his monthly RA bills with all the details required by BHEL on specified date every month covering progress of work in all respects and areas for the previous calendar month.
- vi) Mode of payment and measurement of work completed shall be as per relevant clauses of General Conditions of Contract
- vii) Release of payment in each running bill including PVC Bills where ever applicable will be as per stages of progressive pro rata payments.
- viii) The contractor will be eligible for payment of RA Bills within 30 days of submission of running bill complete in all respects with all documents. It is the responsibility of the contractor to make his own arrangements for making timely payments towards labour wages, statutory payments, outstanding dues etc. and other dues in the meanwhile. All documents like HR Clearance, Quality and Safety Compliances etc. required for processing the RA Bills should be submitted along with RA Bills.
- ix) BHEL shall release payment through Electronic Fund Transfer (EFT)/RTGS. In order to implement this system, Contractor to furnish details pertaining to his Bank Accounts where proceeds will be transferred through BHEL's banker, as per prescribed formats.

For MSMEs, at the time of submission of first RA bill, the subcontractor has to declare whether it is registered on RXIL portal and wishes to receive the proceeds through RXIL portal throughout the contract duration

X.1.1. Documents required for RA Bill:

- a) GST Complied Invoice of the work done as per approved BOQ.
- b) Jointly signed Measurement sheet, Abstract (for civil works), WAM -6 for RA Bill.
- c) Validity of Bank Guarantees as applicable under the contract.
- d) Labour Payment Certificate
- e) Material Reconciliation statement
- f) Test Report of the material as per FQP
- g) Royalty challan for material used (for civil works)
- h) Power of Attorney for representative signing MBs etc, if not submitted earlier.
- i) HR compliance documents (like PF, ESI, Wage sheets etc.)
- j) Any other documents as per customer/statutory requirement

Note :

Site in charge has to certify that all the above required documents have been received and verified and document sl no. a) to d) duly verified are to be sent to Finance alongwith RA bills.

X.2. Final Bill:

- X.2.1. Final Bill' is used for final payment on closing of Running Account for works or for single payment after completion of works. 'Final Bill' shall be submitted as per prescribed format after completion of works as per scope, material reconciliation, removal of temporary structures, return of scrap/surplus material of BHEL. BHEL shall settle the final bills after deducting all liabilities of Contractor to BHEL.

X.2.2. Documents required for Final Bill:

- a) GST Complied Invoice of the work done as per approved BOQ.
- b) Jointly signed Measurement sheet, Abstract (for civil works), WAM -7, WAM-10 (if applicable)
- c) Valid Bank Guarantees as applicable under the contract.
- d) Labour Payment Certificate
- e) 'No claim' certificate from the contractor.
- f) Deviation statement showing the Executed quantities and quantities as per the contract.

- g) Material Reconciliation statement
- h) Submission of As Built Drawings
- i) Submission of balance royalty challan/Clearance from Mining dept. (for civil works)
- j) Material Reconciliation statement duly approved by BHEL
- k) Power of Attorney for representative signing MBs etc, if not submitted earlier.
- l) HR compliance documents (like PF, ESI, Wage sheets etc.)
- m) Compliance report from BHEL/Customer for completion of punch points
- n) Final Delay Analysis.
- o) Any other documents as per customer requirement/statutory requirement.

Note :

Site incharge has to certify that all the above required documents have been received and verified and document sl no. a) to f) duly verified are to be sent to Finance alongwith Completion certificate.

Y. Royalty:

The contractor shall pay the Royalty of sand, aggregate and earth material used for the project and the contractor has to submit the Royalty certificate to BHEL along with the RA bills.

Z. LIMITATION OF LIABILITY:

Notwithstanding anything to the contrary in this Contract or LOA or Work Order or any other mutually agreed document between the parties, the maximum liability, for damages, of the contractor, its servants or agents, shall under no circumstances exceed an amount equal to the Price of the Contract or the Work Order. Neither party shall be liable to the other for any indirect or consequential loss or damage, including but not limited to loss of use, loss of profits, or loss of contracts, or special, punitive, exemplary losses whatsoever, arising out of or in connection with this contract.

This shall not be applicable on the recoveries made by Customer from BHEL on account of Contractor, any other type of recoveries for workmanship, material, T&P etc. due from the contractor”.

AA. Consequential Loss:

Neither party shall be liable to the other for any indirect or consequential loss or damage, including but not limited to loss of use, loss of profits, or loss of contracts, or special, punitive, exemplary losses whatsoever arising out of or in connection with this contract.

NOTE: All other terms and conditions of GCC shall remain unchanged.

PROFORMA OF BANK GUARANTEE (in lieu of SECURITY DEPOSIT)

In consideration of Bharat Heavy Electricals Limited (hereinafter referred to as the 'Employer' which expression shall unless repugnant to the context or meaning thereof, include its successors and permitted assigns) incorporated under the Companies Act, 1956 and having its registered office at BHEL House, Siri Fort, New Delhi-110049 through its Unit at BHEL, Transmission Business Group, Noida (name of the Unit) having agreed to exempt _____ (Name of the Vendor / Contractor / Supplier) with its registered office at _____¹ (hereinafter called the said "Contractor" which term includes supplier), from demand under the terms and conditions of the Contract reference No. _____ dated _____² valued at Rs.....³(Rupees) (hereinafter called the said Contract), of Security Deposit for the due fulfilment by the said Contractor of the terms and conditions contained in the said Contract, on production of a Bank Guarantee for Rs.....⁴ (Rupees.....only),

We _____ (indicate the name and address of the Bank) having its Head Office at _____ (address of the head Office) (hereinafter referred to as the Bank), at the request of _____ [Contractor(s)], being the Guarantor under this Guarantee, do hereby irrevocably and unconditionally undertake to forthwith and immediately pay to the Employer, an amount not exceeding Rs. _____ without any demur, immediately on demand from the Employer and without any reservation, protest, and recourse and without the Employer needing to prove or demonstrate reasons for its such demand

Any such demand made on the bank, shall be conclusive as regards the amount due and payable by the Bank under this guarantee. However, our liability under this guarantee shall be restricted to an amount not exceeding Rs. _____.

We undertake to pay to the Employer any money so demanded notwithstanding any dispute or disputes raised by the Contractor(s) in any suit or proceeding pending before any Court or Tribunal or Arbitrator or any other authority, our liability under this present being absolute and unequivocal.

The payment so made by us under this guarantee shall be a valid discharge of our liability for payment hereunder and the Contractor(s) shall have no claim against us for making such payment.

We, further agree that the guarantee herein contained shall remain in full force and effect during the period that would be taken for the performance of the said Contract and that it shall continue to be enforceable till all the dues of the Employer under or by virtue of the said Contract have been fully paid and its claims satisfied & the Employer certifies that the terms and conditions of the said Contract have been fully and properly carried out by the said contractor(s) or acceptance of the final bill or discharge of this guarantee by the Employer, whichever is earlier. This guarantee shall initially remain in force up to and including _____⁵ and shall be extended from time to time for such period as may be desired by the Employer. Unless a demand or claim under this guarantee is made on us in writing on or before the _____⁶, (3 months more than the present date of validity of Bank Guarantee) we shall be discharged from all the liability under this guarantee thereafter.

We, _____ (indicate the name of the Bank) further agree with the Employer that the Employer shall have the fullest liberty without our consent and without affecting in any manner our obligations hereunder to vary any of the terms and conditions of the said Contract or to extend time of performance by the said contractor(s) from time to time or to postpone for any

time or from time to time any of the powers exercisable by the Employer against the said contractor(s) and to forbear or enforce any of the terms and conditions relating to the said Contract and we shall not be relieved from our liability by any reason of any such variation or extension being granted to the said contractor(s) or for any forbearance, act or omission on the part of the Employer or any indulgence by the Employer to the said contractor(s) or by any such matter or thing whatsoever which under the law relating to sureties would but for this provision have effect of so relieving us.

The Bank also agrees that the Employer at its option shall be entitled to enforce this Guarantee against the Bank as a principal debtor, in the first instance without proceeding against the Contractor and notwithstanding any security or other guarantee that the Employer may have in relation to the Contractor's liabilities.

This Guarantee shall not be determined or affected by liquidation or winding up, dissolution or change of constitution or insolvency of the Contractor but shall in all respects and for all purposes be binding and operative until payment of all money payable to the Employer in terms thereof. This guarantee will not be discharged due to the change in the constitution of the Bank or the Contractor(s).

We,..... BANK lastly undertake not to revoke this guarantee during its currency except with the previous consent of the Employer in writing.

Notwithstanding anything to the contrary contained hereinabove:

- a) The liability of the Bank under this Guarantee shall not exceed.....⁴
- b) This Guarantee shall be valid up to⁵
- c) Unless the Bank is served a written claim or demand on or before _____⁶ all rights under this guarantee shall be forfeited and the Bank shall be relieved and discharged from all liabilities under this guarantee irrespective of whether or not the original bank guarantee is returned to the Bank.

We, _____ Bank, have power to issue this Guarantee under law and the undersigned as a duly authorized person has full powers to sign this Guarantee on behalf of the Bank.

Date _____ Day of _____
for ___ (indicate the name of the Bank) ___

(Signature of Authorised signatory)

¹ ADDRESS OF THE VENDOR /CONTRACTOR / SUPPLIER.

² DETAILS ABOUTTHE NOTICE OF AWARD/CONTRACTREFERENCE

³ CONTRACT VALUE

⁴ BG AMOUNTIN FIGURES AND WORDS

⁵ VALIDITY DATE (At least 3 months more than completion period)

⁶ DATE OF EXPIRY OF CLAIM PERIOD (At least 3 months more than the present date of validity of BG)

Notes:

- 1 The expiry of claim period shall be at least 3 months more than the validity date. It may be ensured that the same is in line with the agreement/ contract entered with the Vendor.

- 2 The BG should be on Non-Judicial Stamp paper/e-stamp paper of appropriate value as per Stamp Act prevailing in the State(s) where the BG is submitted or is to be acted upon or the rate prevailing in the State where the BG was executed, whichever is higher. The Stamp Paper/e-stamp paper shall be purchased in the name of Vendor/Contractor/Supplier /Bank issuing the guarantee.

3 In Case of Bank Guarantees submitted by Foreign Vendors:

- a) **From Nationalized/Public Sector / Private Sector/ Foreign Banks (BG issued by Branches in India)** can be accepted subject to the condition that the Bank Guarantee should be enforceable in the town/city or at nearest branch where the Unit is located i.e. Demand can be presented at the Branch located in the town/city or at nearest branch where the Unit is located.
- b) **From Foreign Banks (wherein Foreign Vendors intend to provide BG from local branch of the Vendor country's Bank)**
 - b.1. In such cases, in the Tender Enquiry/ Contract itself, it may be clearly specified that Bank Guarantee issued by **any of the Consortium Banks only** will be accepted by BHEL. As such, Foreign Vendor needs to make necessary arrangements for issuance of Counter- Guarantee by Foreign Bank in favour of the Indian Bank's (BHEL's Consortium Bank) branch in India. It is advisable that all charges for issuance of Bank Guarantee/ counter- Guarantee should be borne by the Foreign Vendor. The tender stipulation should clearly specify these requirements.
 - b.2. In case, Foreign Vendors intend to provide BG from Overseas Branch of our Consortium Bank (e.g. if a BG is to be issued by SBI Frankfurt), the same is acceptable. However, the procedure at sl.no. b.1 will required to be followed.

BHARAT HEAVY ELECTRICALS LIMITED
DIVISION.....
Running Account Bill
(Para 4.3.1 of Works Accounts Manual)

Name of the Contractor

Name of the Work:

Sanctioned Estimate:

Code No.:

Contract Agreement No.:

Dated:

Division:

Date of written order to commence the Work:

Date of commencement of work:

Due date of completion as per agreement

Date of approval of Competent Authority for time extension as applicable (copy to be enclosed).

Departmental Bill No.

Date:

Sub-Division:

Period of work covered in this bill:

I. ACCOUNT OF WORK EXECUTED

Adhoc payment for work not previously measured **			Item No. of work	Description of work	Quantity as per agreement	Quantity executed upto date	Rate	Unit	Payment on the basis of actual measurement upto date	Quantity executed since last RA bill	Payment on the basis of actual measurement since last running account bill	Remarks
Total as per last running account bill	Since last running account bill	Total upto date										
1	2	3	4	5	6	7	8	9	10	11	12	13

** 1. Whenever payment is made on adhoc basis without actual measurements the amount in whole rupees should be entered in columns 1 to 3 only and not in columns 7 to 12
 2. Whenever there is an entry in column 12 on the basis of actual measurement, the whole of the amount previously paid without detailed measurement should be adjusted by a minus entry in column 2 equivalent to the amount shown in column 1, so that the total upto date in column 3 may become nil.

Total value of work done upto date (A) -----

Deduct value of work shown on the last Running Account Bill (B) -----

Net value of work done since last Running Account Bill (C) -----

Rupees (in words) Only

Note :

Wherever adhoc payments to contractors against running bills are made in accordance with the extant Works Policy, the amount so paid shall be adjusted.

II. MEMORANDUM OF PAYMENTS

		I	II
1.	Total value of work actually measured as per Account No. I, Column 10	(A) -----	-----
2.	Total upto date adhoc payment for work covered by approximate or plan measurements as per Account I, Col. 3	(B) -----	-----
4.	Total upto date payments [(A)+(B)]	(C) -----	-----
5.	Total amount of payments already made as per entry (D) of last Running Account Bill No. dated forwarded to the Accounts Department on	(D) -----	-----
6.	Balance [(C) - (D)]		-----
7.	Payments now to be made:	-----	
	a) by cash / cheque	-----	
	b) by deduction for value of materials supplied by BHEL vide Annexure A attached	-----	
	c) by deduction for hire of tools and plant vide Annexure B attached	-----	
	d) by deduction for other charges vide Annexure C attached	-----	
	e) by deduction on account of security deposit	-----	
	f) by deduction on account of Income Tax		-----

Note : Amounts relating to items 4 to 6 above should be entered in column II and those relating to item 7 in column I. The amount shown against item 6 and the total of item 7 should agree with each other.

III. CERTIFICATE OF THE ENGINEER IN CHARGE

1	The measurements on which the entries in column 7 to 12 of Part I of this Bill (Account of work executed) are based were made by ----- and are reorded at pages - ----- of Measurement Book No. ----- (Name and Designation)
2	Certified that the methods of measurement are correct and the work has been carried out in accordance with the terms and conditions, schedules, specifications and drawings etc. forming part of the contract agreement, subject to deviations included in the deviation statement (Annexure D)
3	Certified that in addition to and quite apart from the quantities of work actually executed as shown in column 10 of Part I, some work has actually been done in connection with several items and the value of the such work is, in no case, less than the adhoc payments as per column 3 of Part I, made or proposed to be made, for the convenience of the contractor in anticipation of, and subject to the results of, detailed measurement which will be made as soon as possible.
4	Certified that measurements by Engineer-incharge and test check of prescribed percentage of measurements by the concerned superior authorities has been carried out.
5	Certified that there are no pending recoveries from the contractor on account of chargeable items (e.g T&P, consumables, material, etc.) issued either by BHEL or by the customer and other recoveries like power, water, quarter, tax liability towards declaration forms etc.
6	Certified that with regard to the free issues, regular reconciliation is being done, completed upto ----- and there are no recoveries pending from the contractor on account of such issues in excess of requirement for execution of work as per contract.
7	Certified that there is no pending recovery for damaged material issued free of cost.
8	Certified that the contractor has fulfilled all the requirements as per contract with reference to statutory obligations (PF, ESI, Minimum Wages, BOCW, Insurance etc.), support services such as service manpower, computer system , T&P etc

Signature of Contractor

Signature of Engineer in Charge

Designation:

Date:

Date:

IV. CERTIFICATE OF THE SENIOR ENGINEER

1	Certified that the measurements have been check measured to the prescribed extent by at site and also by the undersigned and the relevant entries have been initialed in the Measurement Book. (vide pages) (Name and Designation)
2	Certified that all the measurements recorded in the measurement book have been correctly billed for
3	Certified that all recoverable amounts in respect of materials tools and plant etc. and other charges have been correctly made vide annexures A to C attached.

Certified for payment * of Rs. (Rupees only)

* Here specify the net amount payable.

Date:

Signature of Senior Engineer

V. ENTRIES TO BE MADE IN THE FINANCE DEPARTMENT

Accounts Bill No. dated

Entered in Journal Book vide entry No. dated

Passed for Rs.

Less Deductions Rs.

Net amount payable Rs.

(Rupees only)

Payable to Shri / M/s by cheque / cash

Entered in Contractors ledger No. Page

Estimate No :

Debit

Credit

(Gross amount)

(Deductions)

Name of Work :

Account code head

Total

Code No.:

ALLOCATION

Assistant

Date:

Accountant

Date:

Finance Executive

Date:

ANNEXURE C

Form WAM 6 (Contd.)

Statement showing details of other recoveries to be made from the contractor Shri/M/s-----in respect of contract Agreement No.Dated

S. No.	Particulars	Unit	Quantity	Rate	Amount recoverable	Amount recovered up to previous bill	Amount now recovered	Remarks
1	2	3	4	5	6	7	8	9
1	Water charges							
2	Electricity charges							
3	Seignorage charges							
4	Medical charges							
5	Cost of empty gunny bags and empty containers not returned							
6								
7								
8								

TOTAL

Signature of Contractor
Date :

Signature of Engineer in Charge
Date :

Signature of Senior Engineer
Date:

ANNEXURE D
DEVIATION STATEMENT

Name of the Contractor:

Contract Agreement No

Name of Work:

Date:

S. No.	Description of Item	Unit	Quantity as per agreement	Quantity as executed	Quantity further anticipated	Total quantity anticipated on completion	Rate as per agreement	Rate as executed	Amount as per agreement	Amount as executed	Amount further anticipated	Total Amount anticipated on completion	Difference		Reason for deviation with authority, if any
													Excess	Savings	
1	2	3	4	5	6	7	8	9	10	11	12	13	14	15	16

Signature of Engineer in Charge
Date :

Signature of Senior Engineer
Date :

BHARAT HEAVY ELECTRICALS LIMITED
DIVISION.....
.....And Final Bill
(Para 4.3.2 of Works Accounts Manual)

Departmental Bill No:

Date:

Name of the Contractor:

Name of the Work:

Division:

Date of Written order to commence the work:

Sub-Division:

Sanctioned Estimate:

Contract Agreement/ Work Order No:

Date of actual completion of the work:

Date of commencement of the Work:

Dated:

Due date of completion as per Agreement:

I. ACCOUNT OF WORK EXECUTED

Adhoc payment for work not previously measured **			Item no. of the agreement / work order	Description of work	Quantity as per agreement	Quantity executed upto date	Rate	Unit	Payment on the basis of actual measurement upto date	Quantity since last running account bill	Payment on the basis of actual measurement since last running account bill	Remarks
Total as per last running account bill	Since last running account bill	Total upto date										
1	2	3	4	5	6	7	8	9	10	11	12	13

** Whenever there is an entry in column 12 on the basis of actual measurement, the whole of the amount previously paid without detailed measurement should be adjusted by a minus entry in column 2 equivalent to the amount shown in column 1, so that the total upto date in column 3 may become nil.

Total value of work done upto date (A) -----

Deduct value of work shown on the last Running Account Bill (B) -----

Net value of work done since last Running Account Bill (C) -----

Rupees (in words) Only

II. MEMORANDUM OF PAYMENTS

1	Total value of work actually measured as per Account No. I column 10	(A)	-----
2	Deduct amount of payments already made as per last running account bill No. dated	(B)	-----
3	Payment now to be made [(A) - (B)]	(C)	-----
4	Deduct amounts recoverable from the contractor on account of :		
	a) Materials supplied by BHEL vide Annexure A attached		-----
	b) Hire of tools and plant vide Annexure B attached		-----
	c) Other charges vide Annexure C attached		-----
	d) Income Tax		-----
	Total Deductions		-----
5	Balance		-----
6	Refunds of Security Deposit		-----
7	Net amount to be paid to the contractor		-----
	Net value Rupees (in words)		Only

I/ We hereby certify that I/We have performed the work as per the terms and conditions of Contract Agreement/Work Order No.....Dated.....for which payment is claimed as above and that I/We have no further claim under this agreement/work order.

Signature of the Contractor

Date:

III CERTIFICATE OF THE ENGINEER IN CHARGE

1. The measurements on which the entries in columns 7 to 11 of Part I of this bill (Account of work executed) are based were made by.....
are recorded at pages.....of measurement book No..... (Name and Designation)

2. A statement showing the quantities of stores issued to the contractor (whether free or on recovery basis) and their disposal is attached.

Date:

Signature of Engineer incharge

Designation:

IV CERTIFICATE OF THE SENIOR ENGINEER

Form WAM 7 (Contd.)

1. Certified that I have personally inspected the work and that the work has been physically completed on the due date in accordance with the terms and conditions, schedules, specifications and drawings etc., forming part of the contract agreement, subject to the deviations noted in Deviation Statement (Annexure D).
2. Certified that the measurements have been check measured to the prescribed extent by..... and by the undersigned at site and the relevant entries have been initiated in the measurement book (vide pages.....) (Name and Designation)
3. Certified that the methods of measurement are correct.
4. Certified that the measurements have been technically checked with reference to contract drawings, deviations etc.
5. Certified that the measurements recorded in the measurement book have been correctly billed for at the contract rates or approved rates.
6. Certified that all recoverable amounts in respect of stores, tools and plant, water, electricity charges etc. have been correctly made vide Annexures A to C and that there are no other demands outstanding against the contractor on this contract.
7. Certified that the issues of all stores as per statement attached (whether charged to the contractor or direct to the work) have been technically checked and represent fair and reasonable issues for the items of work executed vide Annexure E.
8. Certified that all statutory requirements including PF, ESI, Minimum wages, Insurance, GST, BOCW, etc. are complied with by the Contractor. This should be duly backed by the relevant documents.

Certified for payment of * Rs.....(Rupees.....only).

*Here specify the net amount payable

Signature of Senior Engineer

Date

IV ENTRIES TO BE MADE IN THE FINANCE DEPARTMENT

Passed for.....Rs.....
Less Deductions.....Rs.....
Net Amount Payable.....Rs.....
(Rupees.....only)

Account code head	Debit	Credit
	(Gross Amount)	(Deductions)
TOTAL		

Assistant

Date:

Accountant

Date:

Finance Executive

Date:

**ANNEXURE A
Part I**

Statement showing details of materials issued to the contractor Shri / M/S.....in respect of Contract Agreement / Work Order No.....Dated..... and covered by the agreement.

Sl.No.	Stores Issue Voucher No. and date	Issue voucher No. and date allotted by stores to the SIV	Description of material issued to the contractor	Quantity issued	Quantity actually incorporated in the work	Whether recoverable from the contractor or supplied free	If recoverable from the Contractor				
							Rate at which recoverable	Amount recoverable	Amount recovered upto previous bill	Balance now recovered	Remarks

1	2	3	4	5	6	7	8	9	10	11	12
---	---	---	---	---	---	---	---	---	----	----	----

Total

Signature of Contractor
Date:

Signature of Engineer in Charge
Date:

Signature of Senior Engineer
Date:

**ANNEXURE A
Part II**

Statement showing details of materials issued to the contractor Shri / M/S..... in respect of Contract Agreement / Work Order No.....Dated..... and not covered by the agreement

Sl.No	Stores Issue Voucher No. and Date	Issue Voucher No. and date allotted by stores to the SIV	Description of material issued to the contractor	Quantity issued	Quantity actually incorporated in the work	Issue Rate	Amount recoverable	Amount recovered upto previous bill	Balance now recovered	Remarks
-------	-----------------------------------	--	--	-----------------	--	------------	--------------------	-------------------------------------	-----------------------	---------

1	2	3	4	5	6	7	8	9	10	11
---	---	---	---	---	---	---	---	---	----	----

TOTAL
Add Departmental Charges
Add GST (Wherever applicable)
GRAND TOTAL

Signature of Contractor
Date:

Signature of Engineer-in-Charge
Date:

Signature of Senior Engineer
Date:

Note: Cost of materials recovered in this bill should be shown against item 4 (a) of the memorandum of payments. The amounts of taxes and departmental charges recovered in this bill should be incorporated in Annexure C.

**ANNEXURE D
DEVIATION STATEMENT**

Name of the Contractor:
Name of the Work:

Contract Agreement/Work Order No.
Date:

SL. No.	Description of Item	Unit	Quantity as per agreement	Quantity as executed	Rate as per agreement	Rate as executed	Amount as per agreement	Amount as executed	Difference		Reason for the deviation with authority, if any
									Excess	Savings	
1	2	3	4	5	6	7	8	9	10	11	12

Signature of Engineer in Charge
Date:

Signature of Senior Engineer
Date:

ANNEXURE E

Statement showing the consumption of materials issued to the contractor Shri/M/s..... in respect of Contract Agreement / Work Order No.....Dated.....

Name of the Work:

ON RECOVERY BASIS

SL. No.	Description of material	Unit	Quantity actually issued	Quantity actually incorporated in the work	Balance	Particulars of disposal of balance	Quantity to be issued as per approved data for work actually done	Variation in consumption (difference between column 5 & 8)		Rate chargeable for excess/short consumption, if any	Amount Recoverable for excess/short consumption, including materials not returned, if any	Remarks
								More	Less			
1	Cement											
2	Bricks											
3	Wood											
4	Asbestos Sheet											
5	Iron Material											
6												
7												

Signature of Contractor

Signature of Engineer in Charge

Signature of Senior Engineer

Date:

Date:

Date:

Note

- The quantities shown in columns 4 and 5 above should tally with those shown in columns 5 & 6 respectively of Annexure A (Part I and II)
- Data statement of theoretical consumption should be attached in support of quantity specified in column 8.

ANNEXURE F

Form WAM 7 (Contd.)

Statement showing details of materials issued to the contractor Shri/M/s..... in respect of Contract Agreement / Work Order No.....dated.....

Name of the Work:

FREE OF COST

Sl.No	Stores Issue Voucher No.	Description of material	Unit	Quantity issued	Quantity required as per data	Quantity consumed in the work	Balance (if any)	Nature of disposal for the balance	Rate chargeable for material not returned	Amount recoverable for material not returned	Remarks
1	2	3	4	5	6	7	8	9	10	11	12

Signature of Contractor
Date:

Signature of Engineer in Charge
Date:

Signature of Senior Engineer
Date:

ANNEXURE G
QUESTIONNAIRE TO BE ANSWERED BY THE ENGINEER IN CHARGE AND SENIOR ENGINEER
(Correct particulars and answers to be recorded)

1. Name of the Work:
2. Name of the Contractor:
3. Date of commencement of the Work:
4. Contract agreement /Work Order No. and date:
5. Reference to the supplementary Agreement No. if any:
6. Whether administrative approval and technical sanction has been accorded by the competent authority? If so, cite reference?
7. Whether sanction of the competent authority and financial concurrence of the Finance Department for award of the work has been accorded? If so, cite reference.
8. Whether the work has been completed in time? If not whether penalty has been levied or sanction of the competent authority for extension of time granted and communicated to the Finance Department with reasons for grant of extension? (Due and actual date of completion of the work and reference to letter No. and date granting the extension of time should be given).
9. (a) Whether the rates allowed in the bill have been checked with the contract agreement?
(b) Whether the rates for extra/supplemental items have been approved by the competent authority and the sanction communicated to the Finance Department together with rate analysis? If so, cite reference
10. Whether deviations have been approved by the competent authority? If yes, give reference to the approval; if not, give reasons.
11. Whether the rates of recovery of stores issued to the contractor which are not provided for in the contract agreement have been settled in consultation with Finance?

12. Whether discrepancies pointed out by the Finance department in the stores statement have been reconciled and accepted by the Finance Department?
13. Whether materials issued to the contractor in excess of the theoretical requirements have been returned to the Stores department and the No. and date of such returned stores vouchers have been shown in Stores statement? If not, whether the cost of such excess materials has been recovered at the prescribed rate? Whether consumption statements in respect of materials chargeable to the work have been attached to the bill?
14. Whether consumption of materials shown has been technically checked by Senior Engineer?
15. Whether materials issued and used in the work is not less than that required for consumption in work according to our specifications? If consumption is less, whether necessary recovery has been made in the bill?
16. Whether measurements have been checked by the Engineer and Senior Engineer to the extent required and certificates of check recorded in the measurement books?

17. Whether contractor has signed the bill and the measurement books without reservations? If not, whether reasons have been intimated to the Finance Department?

18. Whether arithmetical calculations have been checked and certificate recorded in the measurement books by a person other than the one who calculated initially?
19. Whether any work was done at the risk and cost of the contractor and whether such cost has been recovered from him? Give particulars.
20. Whether all advance payments on running accounts have been recovered?
21. Whether all the recoveries due for services given to the contractor like rent of accommodation, water charges, electricity charges have been recovered and whether payments made by the company on behalf of the contractor have been adjusted?
22. Whether the files containing abstracts from measurement books/standard measurement books have been completed/updated?
23. Whether hire charges for tools & plant have been recovered and the statement of hire charges with full details attached?
24. Whether the certificate of workmanship and completion of work according to specifications, drawings etc. is recorded by Engineer Incharge/Senior Engineer and whether recoveries have been made for defective works, if any?
25. Whether all corrections in the bill/measurement books etc. have been neatly made and attested and there are no overwriting?
26. Whether final measurements have been taken as soon as possible after completion of the work and the certificate of completion issued? If not, whether reasons for delay have been recorded and communicated to finance department?
27. In respect of quantities reduced in the final bill as compared to the running payment, whether adequate reasons have been recorded and communicated to finance department?
28. Whether the expenditure has been classified correctly according to heads of account recorded in the sanctioned estimate?
29. Whether the work has been completed within the estimated cost? If not, what is the percentage of excess over the sanctioned estimate/ administrative approval? In case the excess is beyond the competency of the Senior Engineer, what action has been taken for obtaining the approval of the authority competent to sanction the excess?
30. (a) If the contractor has furnished bank guarantee in lieu of cash security deposit towards proper execution of works and guarantee against defects during the maintenance period, whether the period of currency of the bank guarantee covers the entire maintenance period?
(b) If not whether security deposit has been proposed to be recovered from the final bill?
31. Whether all the previous audit objections raised on running account bills have been settled? If so, cite references.

Signature of Engineer in Charge
Date:

Signature of Senior Engineer
Date:

ANNEXURE TO MODEL CONCILIATION CLAUSE FOR CONDUCT OF CONCILIATION UNDER THE BHEL CONCILIATION SCHEME, 2018

BRIEF PROCEDURE FOR CONDUCT OF CONCILIATION PROCEEDINGS

1. The proceedings of Conciliation shall broadly be governed by Part-III of the Arbitration and Conciliation Act 1996 or any statutory modification thereof and as provided herein:
2. The party desirous of resorting to Conciliation shall send an invitation/notice in writing to the other party to conciliate specifying all points of Disputes with details of the amount claimed. The party concerned shall not raise any new issue thereafter. Parties shall also not claim any interest on claims/counter-claims from the date of notice invoking Conciliation till the conclusion of the Conciliation proceedings.
3. The party receiving the invitation/notice for Conciliation shall within 30 days of receipt of the notice of Conciliation intimate its consent for Conciliation along with its counter-claims, if any.
4. The Conciliation in a matter involving claim or counter-claim (whichever is higher) up to Rs 5 crores shall be carried out by sole Conciliator nominated by BHEL while in a matter involving claim or counter-claim (whichever is higher) of more than Rs 5 crores Conciliation shall be carried out by 3 Conciliators nominated by BHEL.
5. The Parties shall be represented by only their duly authorized in-house executives/officers and neither Party shall be represented by a Lawyer.
6. The first meeting of the IEC shall be convened by the IEC by sending appropriate communication/notice to both the parties as soon as possible but not later than 30 days from the date of his/their appointment. The hearings in the Conciliation proceeding shall ordinarily be concluded within two (2) months and, in exceptional cases where parties have expressed willingness to settle the matter or there exists possibility of settlement in the matter, the proceedings may be extended by the IEC by a maximum of further 2 months with the consent of the Parties subject to cogent reasons being recorded in writing.
7. The IEC shall thereafter formulate recommendations for settlement of the Disputes supported by reasons at the earliest but in any case within

15 days from the date of conclusion of the last hearing. The recommendations so formulated along with the reasons shall be furnished by the IEC to both the Parties at the earliest but in any case within 1 month from the date of conclusion of the last hearing.

8. Response/modifications/suggestions of the Parties on the recommendations of the IEC are to be submitted to the IEC within time limit stipulated by the IEC but not more than 15 days from the date of receipt of the recommendations from the IEC.
9. In the event, upon consideration, further review of the recommendations is considered necessary, whether by BHEL or by the other Party, then, the matter can be remitted back to the IEC with request to reconsider the same in light of the issues projected by either/both the Parties and to submit its recommendations thereon within the following 15 days from the date of remitting of the case by either of the Parties.
10. Upon the recommendations by the Parties, with or without modifications, as considered necessary, the IEC shall be called upon to draw up the Draft Settlement Agreement in terms of the recommendations.
11. When a consensus can be arrived at between the parties only in regard to any one or some of the issues referred for Conciliation the draft Settlement Agreement shall be accordingly formulated in regard to the said Issue(s), and the said Settlement Agreement, if signed, by the parties, shall be valid only for the said issues. As regards the balance issues not settled, the parties may seek to resolve them further as per terms and conditions provided in the contract.
12. In case no settlement can be reached between the parties, the IEC shall by a written declaration, pronounce that the Conciliation between the parties has failed and is accordingly terminated.
13. Unless the Conciliation proceedings are terminated in terms of para 22 (b), (c) & (d) herein below, the IEC shall forward his/its recommendations as to possible terms of settlement within one (1) month from the date of last hearing. The date of first hearing of Conciliation shall be the starting date for calculating the period of 2 months.

14. In case of 3 members IEC, 2 members of IEC present will constitute a valid quorum for IEC and meeting can take place to proceed in the matter after seeking consent from the member who is not available. If necessary, videoconferencing may be arranged for facilitating participation of the members. However, the IEC recommendations will be signed by all members. Where there is more than one (1) Conciliator, as a general rule they shall act jointly. In the event of differences between the Members of IEC, the decision/recommendations of the majority of the Members of IEC shall prevail and be construed as the recommendation of the IEC.
15. The Draft Settlement Agreement prepared by the IEC in terms of the consensus arrived at during the Conciliation proceedings between the Parties shall be given by the IEC to both the parties for putting up for approval of their respective Competent Authority.
16. Before submitting the draft settlement agreement to BHEL's Competent Authority viz. the Board Level Committee on Alternative Dispute Resolution (BLCADR) for approval, concurrence of the other party's Competent Authority to the draft settlement agreement shall be obtained by the other party and informed to BHEL within 15 days of receipt of the final draft settlement agreement by it. Upon approval by the Competent Authority, the Settlement Agreement would thereafter be signed by the authorized representatives of both the Parties and authenticated by the members of the IEC.
17. In case the Draft Settlement Agreement is rejected by the Competent Authority of BHEL or the other Party, the Conciliation proceedings would stand terminated.
18. A Settlement Agreement shall contain a statement to the effect that each of the person(s) signing thereto (i) is fully authorized by the respective Party(ies) he/she represents, (ii) has fully understood the contents of the same and (iii) is signing on the same out of complete freewill and consent, without any pressure, undue influence.
19. The Settlement Agreement shall thereafter have the same legal status and effect as an arbitration award on agreed terms on the substance of the dispute rendered by an arbitral tribunal passed under section 30 of the Arbitration and Conciliation Act, 1996.
20. Acceptance of the Draft Settlement Agreement/recommendations of the Conciliator and/or signing of the Settlement Agreement by BHEL shall

however, be subject to withdrawal/closure of any arbitral and/or judicial proceedings initiated by the concerned Party in regard to such settled issues.

21. Unless otherwise provided for in the agreement, contract or the Memorandum of Understanding, as the case may be, in the event of likelihood of prolonged absence of the Conciliator or any member of IEC, for any reason/incapacity, the Competent Authority/Head of Unit/Division/Region/Business Group of BHEL may substitute the Conciliator or such member at any stage of the proceedings. Upon appointment of the substitute Conciliator(s), such reconstituted IEC may, with the consent of the Parties, proceed with further Conciliation into the matter either de-novo or from the stage already reached by the previous IEC before the substitution.

22. The proceedings of Conciliation under this Scheme may be terminated as follows:

- a. On the date of signing of the Settlement agreement by the Parties; or,
- b. By a written declaration of the IEC, after consultation with the parties, to the effect that further efforts at conciliation are no longer justified, on the date of the declaration; or,
- c. By a written declaration of the Parties addressed to the IEC to the effect that the Conciliation proceedings are terminated, on the date of the declaration; or,
- d. By a written declaration of a Party to the other Party and the IEC, if appointed, to the effect that the Conciliation proceedings are terminated, on the date of the declaration.
- e. On rejection of the Draft Settlement Agreement by the Competent Authority of BHEL or the other Party.

23. The Conciliator(s) shall be entitled to following fees and facilities:

Sl No	Particulars	Amount
1	Sitting fees	Each Member shall be paid a Lump Sum fee of Rs 75,000/- for the whole case payable in terms of paragraph No. 27 herein below.
2	Towards drafting of settlement agreement	In cases involving claim and/or counter-claim of up to Rs 5crores. Rs 50,000/- (Sole Conciliator)

Sl No	Particulars	Amount
		<p>In cases involving claim and/or counter-claim of exceeding Rs 5 crores but less than Rs 10 crores. Rs 75,000 (per Conciliator)</p> <p>In cases involving claim and/or counter-claim of more than Rs 10 crores. Rs 1,00,000/- (per Conciliator)</p> <p>Note: The aforesaid fees for the drafting of the Settlement Agreement shall be paid on Signing of the Settlement Agreement after approval of the Competent Authority or Rejection of the proposed Settlement Agreement by the Competent Authority of BHEL.</p>
3	Secretarial expenses	<p>Rs 10,000/- (one time) for the whole case for Conciliation by a Sole Member IEC.</p> <p>Where Conciliation is by multi member Conciliators –Rs 30,000/- (one time)- to be paid to the IEC</p>
4	<p>Travel and transportation and stay at outstation</p> <p>i) Retired Senior Officials of other Public Sector Undertakings (pay scale wise equivalent to or more than E-8 level of BHEL)</p>	<p>As per entitlement of the equivalent officer (pay scale wise) in BHEL.</p>
	Others	<p>As per the extant entitlement of whole time Functional Directors in BHEL.</p>

Sl No	Particulars	Amount
		Ordinarily, the IEC Member(s) would be entitled to travel by air Economy Class.
5	Venue for meeting	Unless otherwise agreed in the agreement, contract or the Memorandum of Understanding, as the case may be, the venue/seat of proceedings shall be the location of the concerned Unit / Division / Region / Business Group of BHEL. Without prejudice to the seat/venue of the Conciliation being at the location of concerned BHEL Unit / Division / Region / Business Group, the IEC after consulting the Parties may decide to hold the proceedings at any other place/venue to facilitate the proceedings. Unless, Parties agree to conduct Conciliation at BHEL premises, the venue is to be arranged by either Party alternately.

24. The parties will bear their own costs including cost of presenting their cases/evidence/witness(es)/expert(s) on their behalf. The parties agree to rely upon documentary evidence in support of their claims and not to bring any oral evidence in IEC proceedings.
25. If any witness(es) or expert(s) is/are, with the consent of the parties, called upon to appear at the instance of the IEC in connection with the matter, then, the costs towards such witness(es)/expert(s) shall be determined by the IEC with the consent of the Parties and the cost so determined shall be borne equally by the Parties.
26. The other expenditures/costs in connection with the Conciliation proceedings as well as the IEC's fees and expenses shall be shared by the Parties equally.
27. Out of the lump sum fees of Rs 75,000/- for Sitting Fees, 50% shall be payable after the first meeting of the IEC and the remaining 50% of the Sitting Fees shall be payable only after termination of the conciliation proceedings in terms of para 22 hereinabove.

28. The travelling, transportation and stay at outstation shall be arranged by concerned Unit as per entitlements as per Serial No. 3 of the Table at para 23 above, and in case such arrangements are not made by the BHEL Unit, the same shall be reimbursed to the IEC on actuals limited to their entitlement as per Serial No. 4 of the Table at Para 23 above against supporting documents. The IEC Member(s) shall submit necessary invoice for claiming the fees/reimbursements.
29. The Parties shall keep confidential all matters relating to the conciliation proceedings. Confidentiality shall extend also to the settlement agreement, except where its disclosure is necessary for purposes of its implementation and enforcement or as required by or under a law or as per directions of a Court/Governmental authority/regulatory body, as the case may be.
30. The Parties shall not rely upon or introduce as evidence in any further arbitral or judicial proceedings, whether or not such proceedings relate to the Disputes that is the subject of the Conciliation proceedings:
 - a. Views expressed or suggestions made by the other party in respect of a possible settlement of the Disputes;
 - b. admissions made by the other party in the course of the Conciliator proceedings;
 - c. proposals made by the Conciliator;
 - d. The fact that the other Party had indicated his willingness to accept a proposal for settlement made by the Conciliator.
31. The Parties shall not present the Conciliator(s) as witness in any Alternative Dispute Resolution or Judicial proceedings in respect of a Disputes that is/was the subject of that particular Conciliation proceeding.
32. None of the Conciliators shall act as an arbitrator or as a representative or counsel of a Party in any arbitral or judicial proceeding in respect of a Disputes that is/was the subject of that particular Conciliation proceeding.
33. The Parties shall not initiate, during the Conciliation proceedings, any arbitral or judicial proceedings in respect of a Disputes that is the subject matter of the Conciliation proceedings except that a Party may initiate arbitral or judicial proceedings where, in his opinion, such proceedings are necessary for preserving his rights including for preventing expiry of period of limitation. Unless terminated as per the provisions of this Scheme, the Conciliation proceedings shall continue

notwithstanding the commencement of the arbitral or judicial proceedings and the arbitral or judicial proceedings shall be primarily for the purpose of preserving rights including preventing expiry of period of limitation.

34. The official language of Conciliation proceedings under this Scheme shall be English unless the Parties agree to some other language.

Format 2 to BHEL Conciliation Scheme, 2018

**FORMAT FOR SEEKING CONSENT FOR REFERRING THE DISPUTES TO
CONCILIATION THROUGH IEC**

To,

M/s. (Stakeholder's name)

**Sub: Resolution of the Disputes through conciliation by Independent
Expert Committee (IEC).**

Ref: Contract No/MoU/Agreement/LOI/LOA& date _____.

Sir,

With reference to above referred Contract/MoU/Agreement/LOI/LOA, you have raised certain Disputes/claims. Vide your letter dated_____ you have requested BHEL to refer the Disputes/claims to IEC for Conciliation.

We are enclosing herewith Format (3) for giving consent and the terms and conditions of BHEL Conciliation Scheme, 2018 governing conciliation through IEC. You are requested to give your unconditional consent to the said terms and conditions of the Scheme by returning the same duly sealed and signed on each page. On receipt of your consent, matter will be put to the Competent Authority for consideration and decision.

Please note that BHEL has also certain claims against you (if applicable). BHEL reserves its right to agree or not to agree conciliation of the said disputes through BHEL and this letter is being issued without prejudice to BHEL's rights and contentions available under the contract and law.

Yours faithfully,

Representative of BHEL

Format 3 to BHEL Conciliation Scheme, 2018
FORMAT FOR GIVING CONSENT BY
CONTRACTOR/VENDOR/CUSTOMER/COLLABORATOR/CONSORTIUM PARTNERS FOR REFERRING THE DISPUTES TO CONCILIATION THROUGH IEC

To,

BHEL

.....

Sub: Resolution of Disputes through Conciliation by Independent Expert Committee (IEC).

Ref: Contract/MoU/Agreement/LOI/LOA No & date____

With reference to above referred contract, our following bills/invoices/claims submitted to BHEL are still unpaid giving rise to Disputes:

SL. no.	Claim Description	Bill submitted to BHEL (no. and date)	Amount of the bill/claim	Amount received from BHEL	Outstanding Amount

Accordingly we request you to kindly refer the Disputes in respect of above claims to IEC for Conciliation.

We hereby agree and give our unconditional consent to the terms and conditions of BHEL Conciliation Scheme, 2018 governing conciliation through IEC. We have signed the same on each page and enclosed it for your consideration.

Yours faithfully,

(Signature with stamp)

Authorized Representative of Contractor

Name, with designation

Date

Format 5 to BHEL Conciliation Scheme, 2018
STATEMENT OF CLAIMS/COUNTER CLAIMS TO BE SUBMITTED TO
THE IEC BY BOTH THE PARTIES

1. Chronology of the Disputes
2. Brief of the Contract/MoU/Agreement/LOI/LOA
3. Brief history of the Disputes:
4. Issues:
5. Details of Claim(s)/Counter Claim(s):

SI. No.	Description of claim(s)/Counter Claim	Amount (in INR)Or currency applicable in the contract	Relevant contract clause

6. Basis/Ground of claim(s)/counter claim(s) (along with relevant clause of contract)

Note– *The Statement of Claims/Counter Claims may ideally be restricted to maximum limit of 20 pages. Relevant documents may be compiled and submitted along with the statement of Claims/Counter Claims. The statement of Claims/Counter Claims is to be submitted to all IEC members and to the other party by post as well as by email.*

BILL OF QUANTITY CUM PRICE SCHEDULE (Annexure-I)

Name of Project : ±800 KV, 6000 MW HVDC Bhadla Station

Name of Work : Civil works of Open & closed store along with approach road to stores for ±800 KV, 6000 MW HVDC Bhadla, Rajasthan

Tender Spec No. TBSM/HVDC BHADLA/CIVIL/STORE/TENDER/26-27 dt. 15-05-2026

S. No.	Description of Item	Unit	Quantity	Unit Rate excl. GST (Rs)	Amount excl. GST (Rs)
Annexure-I					
1	Construction of Open Store including all activity as per Technical Specification having document No. TBSM/Std-Spec/Open-Str/02, R02 & tender drawing.	sqm	4000	765.00	3060000.00
2	Construction of closed Store Type C of 200 Sqmtr (20x10 Sqm) each size including all activity as per Technical Specification having Document No. TBSM/Std-Spec/Cov-Str/01, R02 & tender drawing.	Nos	2	1214700.00	2429400.00
3	3.75m wide Bitumen road with earthen shoulder as per drawing and TS and including 225 mm thick WBM in three equal layers of 75 mm each including excavation, rolling, compacting etc all as per CPWD specification & as per direction of the Engineer Incharge.	RM	25	2912.00	72800.00
4	All civil works for Drains construction of Section A-A including crossings if any as per technical specification and tender drawings, complete in all respect with all labour and materials & as per direction of the Engineer Incharge.	RM	100	1875.44	187544.14
5	All civil works for Drains construction of Section B-B including crossings if any as per technical specification and tender drawings, complete in all respect with all labour and materials & as per the direction of the Engineer Incharge.	RM	10	3220.70	32207.04
6	Earthwork in excavation & filling in all types of soil and soft/disintegrated rock in open areas/nallas/channels, to the required slopes, shapes, levels, elevations and profile, including trimming of bottom and slopes of excavation, bailing out rain (dewatering), pumping, removal of slush, preparing embankments/marginal banks, loosening, dressing, spreading material in layers not exceeding 200mm, as per direction of Engineer-in-Charge, water flooding, compacting to achieve 95% consolidation at optimum moisture content, finishing etc. all complete, for all leads and lifts within leveling boundary, including disposal of surplus earth and stacking of unsuitable material within a lead of 2.0 Km beyond substation boundary, with all labour, material, tools, tackles and equipment, safeguards and incidentals, Royalty, taxes, etc. as necessary, as per drawings, specification and directions of the Engineer-in-Charge. Clearing of jungle is included in this item. (Only excavation/cutting will be measured for payment purpose.)	cum	1000	122.40	122400.00
7	Supply of earth (excluding rock & boulders) at site including royalty, carriage and filling in specified areas in layers not exceeding 200mm in depth, compacting under optimum moisture condition to achieve 95% of Proctor density, finishing etc. all complete, for all leads & lifts, with all labour, material, tools, tackles, equipments, safeguards & incidentals as necessary as per drawings, specification and direction of the Engineer- in- Charge.	cum	25	307.90	7697.50

BILL OF QUANTITY CUM PRICE SCHEDULE (Annexure-I)

Name of Project : ±800 KV, 6000 MW HVDC Bhadla Station

Name of Work : Civil works of Open & closed store along with approach road to stores for ±800 KV, 6000 MW HVDC Bhadla, Rajasthan

Tender Spec No. TBSM/HVDC BHADLA/CIVIL/STORE/TENDER/26-27 dt. 15-05-2026

S. No.	Description of Item	Unit	Quantity	Unit Rate excl. GST (Rs)	Amount excl. GST (Rs)
8	Supplying, filling and compacting stone boulders mixed with sand at the site under floors, foundations, roads, cable trenches, drains, etc. in layers not exceeding 250mm thickness including royalty, carriage, ramming, watering, compacting, etc. all complete, for all leads and lift with all labour, material, tools, tackles, equipments, safeguards & incidentals as necessary as per specification and direction - of - Engineer -in- charge.	cum	10	1336.50	13365.00
9	Supplying, filling and compacting CNS material as per specification underfloors, foundations, roads, cable trenches, drains, etc in layers not exceeding 200 mm thickness.	cum	10	1074.90	10749.00
Total Price (Excluding GST)					5936162.69

Validate

Print

Help

Percentage BoQ

Tender Inviting Authority: BHEL, TBG- SubContracting Department, Sector 16A Noida, UP

Name of Work: EXECUTION AND HANDING OVER OF CIVIL WORKS OF OPEN AND CLOSED STORE ALONG WITH APPROACH ROAD TO STORES FOR ± 800 KV , 6000 MW HVDC BHADLA, RAJASTHAN

Contract No: TBSM/HVDC BHADLA/CIVIL/STORE/TENDER/26-27 DATE: 15-05-2026

Name of the Bidder/ Bidding Firm / Company :						
PRICE SCHEDULE						
(This BOQ template must not be modified/replaced by the bidder and the same should be uploaded after filling the relevent columns, else the bidder is liable to be rejected for this tender. Bidders are allowed to enter the Bidder Name and Values only)						
NUMBER #	TEXT #	NUMBER #	TEXT #	NUMBER	NUMBER #	TEXT #
Sl. No.	Item Description	Quantity	Units	Estimated Rate in Rs. P	TOTAL AMOUNT Without Taxes in Rs. P	TOTAL AMOUNT In Words
1	2	4	5	6	53	55
1	Total amount as per rates in BOQ (as per Annexure-I) for EXECUTION AND HANDING OVER OF CIVIL WORKS OF OPEN AND CLOSED STORE ALONG WITH APPROACH ROAD TO STORES FOR ± 800 KV , 6000 MW HVDC BHADLA, RAJASTHAN." - Excluding GST	1.000	Nos	5936163.00	5936163.00	INR Fifty Nine Lakh Thirty Six Thousand One Hundred & Sixty Three Only
Total in Figures					5936163.00	INR Fifty Nine Lakh Thirty Six Thousand One Hundred & Sixty Three Only
Quoted Rate in Figures			Select		0.000	INR Zero Only
Quoted Rate in Words			INR Zero Only			

SECTION - 1

SCOPE, SPECIFIC TECHNICAL REQUIREMENTS & QUANTITIES

1.1.0 SCOPE

1.1.1 The scope of work under this specification is civil works of Open & closed store along with approach road to stores for ± 800 KV, 6000 MW HVDC Bhadhla, Rajasthan. The Customer is RAJASTHAN PART I POWER TRANSMISSION LIMITED (M/s Adani)

1.1.2 The Civil Works under this package shall generally include, *but not limited to* , following:

- (i) Construction of Open and Closed Store
- (ii) Approach road to store area
- (iii) Drain
- (iv) Site Levelling of Store area if required
- (v) Any other work required for the project.

1.1.3 The works to be performed in the above construction includes preparation of bar bending schedules, based on the drawings released for construction and getting the same approved by the Engineer-in-charge plus the execution of the work including providing of all labour, supervision, materials, scaffolding, power, fuel, construction equipments, tools and plants, supplies, transportation, all incidental items necessary for successful completion of the work including contractor's supervision and in strict accordance with the drawings and specifications and with inspection and testing standards.

The nature of work shall generally involve excavation in all type of soil/rock including dewatering, shoring, strutting, and filling under and around structures, backfilling with available excavated earth (including rock) around completed structures, disposal of surplus soil, steel/wooden ply formwork, providing necessary steel embedments and other inserts, drainage work, concreting, brickwork, flooring and finishing etc. and all other works in stores all complete as per detailed specification, drawings and directions of Engineer-in-charge.

The bidder shall fully apprise himself of the prevailing conditions at the proposed site, climatic conditions including monsoon patterns, local conditions and site specific parameters, soil parameters, availability of construction water & material and shall include for all such conditions and contingent measures in the bid, including those which may not have specifically brought out in the specifications. The bidder shall submit the declaration conforming knowledge about site conditions as per attached Annexure-A

The material specification, workmanship and acceptance criteria shall be as per CPWD specification/ relevant BIS.

1.2.0 SPECIFIC TECHNICAL REQUIREMENT

1.2.1 The specific technical requirements for the execution of civil works shall be as per Standard specification (Section-2) /I.S Specification.

1.3.0 BILL OF QUANTITIES

1.3.1 The Bill of Quantity cum price schedule shall be as per page 1.3

1.3.2 The quantities indicated in the 'Bill of Quantity cum price schedule' are indicative and can vary to any extent. Contractor shall not be entitled for any claim for any such variation in the quantities.

1.3.3 The provision of Bill of Quantity cum price schedule, specifications and drawings shall be read in conjunction with each other and in case of conflict amongst them, the clarification shall be obtained from the Engineer-in-charge whose decision shall be final and binding.

1.3.4 METHOD OF MEASUREMENT:**1.3.4.1 Open and Closed Store:**

This item is inclusive of all works as per Technical specification of Open and Closed Store. Nothing Extra will be paid.

1.3.4.2 SITE LEVELLING WORK:

The item site levelling works includes Contouring of area to be levelled as per technical specification. The final area of levelling will be decided during detailed engineering.

Mode of measurement of this item is in Cum of earthwork as per BOQ and technical specification. The contouring of the area to be levelled is in the scope as per technical specification & the rate of this is deemed to be included in quoted rates of this item.

The quantity of excavation in all types of soil and soft/disintegrated rock shall be worked out by using initial and final levels. No void deduction shall be made to calculate net quantity of earth work. Only Excavation/cutting will be measured for payment purpose. The unit of measurement shall be in cubic metre.

The unit rate shall include all lifts and all leads within levelling boundary. It also includes disposal of surplus earth and stacking of unusable material up the lead of 2000 meters beyond the levelling boundary. Rate of item shall include all operations specified in the respective clause of customer technical specification.

1.3.4.3 Approach Road:

The measurement of bituminous road shall be made on the basis of Running meter (RM), of the top bituminous completed surface of the road and shall include all items such as earth work (excavation, disposal etc.), compaction, rolling, watering, WBM, Kerb stone, grating, shoulder etc wherever indicated complete as per drawing including premix carpet etc complete. Usage of WMM in place of WBM shall be done with approval of BHEL without any additional financial implication.

1.3.4.4 Drain:

Drainage system shall be based on the standard sections & Drainage layout as per BHEL Released drawings. Drains shall be measured in running meter including culvert (if required). The rate shall include the cost of all works such as Excavation, Backfilling, PCC, Misc. Structural Steel, brickwork, screed concrete, plastering, Hume Pipe etc. as per drawings and technical specifications.

BILL OF QUANTITY CUM PRICE SCHEDULE

Name of Project : ±800 KV, 6000 MW HVDC Bhadhla Station

Name of Work : Civil works of Open & closed store along with approach road to stores for ±800 KV, 6000 MW HVDC Bhadhla, Rajasthan.

S. No.	Description of Item	Unit	Quantity	Unit Rate excl. GST (Rs)	Amount excl. GST (Rs)
Annexure-I					
1	Costruction of Open Store including all activity as per Technical Specification having document No. TBSM/Std-Spec/Open-Str/02, R02 & tender drawing.	sqm	4000	765.00	3060000.00
2	Construction of closed Store Type C of 200 Sqmtr (20x10 Sqm) each size including all activity as per Technical Specification having Document No. TBSM/Std-Spec/Cov-Str/01, R02 & tender drawing.	Nos	2	1214700.00	2429400.00
Annexure-II					
1	3.75m wide Bitumen road with earthen shoulder as per drawing and TS and including 225 mm thick WBM in three equal layers of 75 mm each including excavation, rolling, compacting etc all as per CPWD specification & as per direction of the Engineer Incharge.	RM	25	2912.00	72800.00
2	All civil works for Drains construction of Section A-A including crossings if any as per technical specification and tender drawings, complete in all respect with all labour and materials & as per direction of the Engineer Incharge.	RM	100	1875.44	187544.14
3	All civil works for Drains construction of Section B-B including crossings if any as per technical specification and tender drawings, complete in all respect with all labour and materials & as per the direction of the Engineer Incharge.	RM	10	3220.70	32207.04
4	Earthwork in excavation & filling in all types of soil and soft/disintegrated rock in open areas/nallas/channels, to the required slopes, shapes, levels, elevations and profile, including trimming of bottom and slopes of excavation, bailing out rain (dewatering), pumping, removal of slush, preparing embankments/marginal banks, loosening, dressing, spreading material in layers not exceeding 200mm, as per direction of Engineer-in-Charge, water flooding, compacting to achieve 95% consolidation at optimum moisturecontent, finishing etc. all complete, for all leads and lifts within leveling boundary, including disposal of surplus earth and stacking of unsuitable material within a lead of 2.0 Km beyond substation boundary, with all labour, material, tools, tackles and equipment, safeguards and incidentals, Royalty, taxes, etc. as necessary, as per drawings, specification and directions of the Engineer-in-Charge. Clearing of jungle is included in this item. (Only excavation/cutting will be measured for payment purpose.)	cum	1000	122.40	122400.00
5	Supply of earth (excluding rock & boulders) at site including royalty, carriage and filling in specified areas in layers not exceeding 200mm in depth, compacting under optimum moisture condition to achieve 95% of Proctor density, finishing etc. allcomplete, for all leads & lifts, with all labour, material, tools, tackles, equipments, safeguards & incidentals as necessary as perdrawings, specification and direction of the Engineer- in- Charge.	cum	25	307.90	7697.50
6	Supplying, filling and compacting stone boulders mixed with sand at the site under floors, foundations, roads, cable trenches, drains, etc. in layers not exceeding 250mm thickness including royalty, carriage, ramming, watering, compacting, etc. all complete, for all leads and lift with all labour, material, tools, tackles, equipments, safeguards & incidentals as necessary as per specification and direction - of - Engineer -in- charge.	cum	10	1336.50	13365.00
7	Supplying, filling and compacting CNS material as per specification underfloors, foundations, roads, cable trenches, drains, etc in layers not exceeding 200 mm thickness.	cum	10	1074.90	10749.00
				Total Amount	5936162.69

SECTION - 1

SCOPE, SPECIFIC TECHNICAL REQUIREMENT &
QUANTITIES

SECTION- 2 STANDARD TECHNICAL SPECIFICATION

A.)SITE LEVELLING

1.0 GENERAL

1.1 Introduction

These Specifications shall apply to all such works as are required to be executed under the Contract or otherwise directed by the Engineer-in-Charge. In every case the work shall be carried out to the satisfaction of the Engineer-in-Charge and conform to the location, lines, grades and cross-sections shown on the drawings *or* as indicated by the Engineer-in-Charge. The quality of work and materials shall comply with the requirements set forth in the succeeding sections. Where the drawings and Specifications describe a portion of the work only in general terms, and not in complete details, it shall be understood that only the best general practice is to prevail, materials and workmanship of the best quality are to be employed and the instructions of the Engineer-in-Charge are to be fully complied with.

1.2 Scope of Work

The scope of work covered under this specification is as follows:

- (i) Site Clearance
- (ii) Site levelling;

The work to be performed under these specifications consists of providing all labour, supervision, materials, planking and strutting, power, fuel, construction equipments, tools and plants, supplies, transportation, storage, insurance, royalty and all incidental items not shown or specified by reasonably implied *or* necessary for successful completion of work including contractor's supervision and in strict accordance with drawing and specifications.

The scope may however vary based on the specific requirement of various works/site, which shall be specified by the Owner in the form of addendum/modifications.

1.3 General Rules for the measurement of works for payment

All measurements shall be made in the metric system. Different items of work shall be measured in accordance with the procedures set forth in the relevant sections read in conjunction with the General Conditions of Contract. All measurements and computations, unless otherwise indicated, shall be carried nearest to the following limits:

- | | |
|---|----------------------|
| (i) Length and breadth | ... 10 mm |
| (ii) Height, depth or thickness of work | ... 5 mm |
| (iii) Areas | ... 0.01 Sq. metres. |
| (iv) Cubic contents | ... 0.01 Cu. metres. |

In recording dimensions of work the sequence of length, width and height or depth or thickness shall be followed.

2.0 SITE CLEARANCE:

2.1 Jungle Clearance

The work shall consist of removing and disposing of all materials such as bushes, woods, shrubs, grass, stumps, rubbish, rank vegetation, roots, foreign materials, etc., which in the opinion of the Engineer-in-Charge are unsuitable for incorporation in the works, from within the limits and areas as may be specified on the drawings or directed by the Engineer-in-Charge.

All materials arising from clearing and grubbing operation shall be the property of customer and be disposed of by the Contractor as hereinafter provided or directed by the Engineer-in-Charge within a lead of 2000 m beyond the periphery of area cleared. Trunks and branches of trees shall be cleaned of limbs and tops and stacked neatly at places as indicated by the Engineer-in-Charge. Also boulders, stones and other materials usable shall be neatly stacked. All products of clearing and grubbing which in the opinion of the Engineer-in-Charge cannot be used or auctioned shall be cleared away to waste areas and burnt, if so desired, at locations away within a lead of 2000 m beyond the periphery of area cleared in a manner as directed by the Engineer-in-Charge. Care shall be taken to see that unsuitable waste materials are disposed of in such a manner that there is no likelihood of these getting mixed up with the materials meant for filling.

3.0 SITE LEVELLING WORK:

3.1 Description:

Before the earth work is started, the area coming under cutting and filling shall be cleared of shrubs, rank vegetation, grass, bush, wood, tress and sapling of girth up to 30 cm at a height of one meter above ground level, stacking of trees/saplings cut and rubbish removed up to 2000 meter beyond levelling boundary, the roots of trees and saplings shall be removed and the holes and hollows filled up with the earth, rammed and levelled. The aforesaid activities shall be deemed to be included in the item of earth work and nothing extra shall be payable on this account. Site levelling work shall consist of excavation, filling and other levelling operations, removal and satisfactory disposal of all materials necessary for achieving desired formation level, if required, in accordance with the requirements of these specifications and the lines, grades and cross-sections shown in the drawings or indicated by the Engineer-in-Charge. The work shall include the hauling and stacking of or the hauling to levelling site, of suitable materials as required, as also the disposal of unsuitable materials in specified manner; and the trimming and finishing of works. The work to be performed under the specification consist of providing all labour, supervision, materials, planking and strutting, power, fuel, mechanical implements, tools and plants, supplies, transportation, storage, insurance, royalty, taxes and all incidental items not shown or specified but reasonably implied or necessarily implied for successful completion of the work, and in strict accordance with the drawings and specifications. The nature of work shall generally involve clearance of site, excavation in all kinds of soils, soft/disintegrated rock, hard rock, dewatering, transporting of excavated earth, filling, consolidation of earth, levelling benching, giving slopes and making formations as per drawings and instructions of the Engineer-in-Charge.

3.2 Classification of Excavated Materials:

All materials involved in excavation shall be classified by the Engineer-in-Charge in the following groups:

3.3 Site Levelling Operations:

3.3.1 Setting out and marking profiles.

After the site has been cleared, the limits of site levelling shall be set out true to lines, curves, slopes, grades and sections as directed by the Engineer-in-Charge. The Contractor shall provide all labour, survey instruments and materials such as strings, pegs, nails, bamboos, stones, lime, mortar, concrete, etc., required in connection with the setting out of works and establishment of bench marks. A grid system of co-ordinates shall be established by the Contractor at the site. The Contractor shall be responsible for the maintenance of permanent reference pillars, bench marks and other marks and stakes as long as in the opinion of the

Engineer-in-Charge they are required for the work. All such marks/pillars shall be removed by the Contractor at his own cost as soon as the purpose is over.

Masonry pillars shall be erected at suitable places in the area to serve as bench marks for the execution of the work. These bench marks shall be connected with G.T.S. of any other permanent bench mark approved by the Engineer-in-Charge. Necessary profiles with pegs, bamboos and strings or "Burgeis" shall be made to show the correct formation levels before the work is started and the same shall be approved by the Engineer-in-Charge. The contractor shall supply all labour, tools, equipment, materials, safeguards and incidentals necessary for setting out and making profiles and burgeis & pillars for the work at his own cost. The profiles and burgeis shall be maintained during the execution of the work. Marks/pillars shall invariably be diagonal unless otherwise directed, and should be such that their average height is representative of average depths.

3.3.2 Excavation and Filling -General

All excavations shall be carried out in conformity with the directions laid Here in under and in a manner approved by the Engineer-in-Charge. The work shall be so done that the suitable materials available from excavation are satisfactorily utilised as decided upon before disposal. While planning or executing excavation, the Contractor shall take all adequate precautions against soil erosion, water pollution, air pollution etc. The excavations shall conform to the lines, grades, side slopes and levels shown on the drawings or directed by the Engineer-in-Charge. The Contractor shall not excavate outside the slopes or below the established grade or loosen any material outside the limits of excavation. Subject to the permitted tolerances, any excess depth excavated below the specified levels shall be made good at the cost of the Contractor with suitable material of similar characteristics and compacted to the required density and to the satisfaction of the Engineer-in-Charge.

All debris and loose material on the slopes of cuttings shall be removed. Cutting shall be done from top to bottom. Under no circumstances undermining or undercutting shall be allowed. Final surface shall be neatly dressed. The earth from cutting shall be directly used for filling and no extra claim for double handling of earth shall be admissible to the contractor. All cutting shall be done to the required slopes/shapes, levels and profiles as indicated in the construction drawing with a negative tolerance of 100 mm. If cutting be taken deeper, it shall be brought to the required level as per the instructions of the Engineer-in-Charge, by filling in with the earth and duly Consolidating at the Contractor's cost.

Filling shall be done in regular horizontal layers not exceeding 20 cm. in depth. The earth shall be free from all roots, grass, rubbish and humps and clods exceeding 80mm in any direction shall be broken. Each layer shall be consolidated by breaking clods and Compacting each layer with wooden /steel rammer or movement of dozers, trucks or 8/10 tonne power road rollers, sheep foot roller and vibratory compactors etc. so that compaction of 95% of the maximum dry density is achieved at optimum moisture content.

Tests for Compaction are to be performed as per the procedures laid down in the relevant I.S. Codes of practice and Field Quality Plan provided by BHEL. In cases of compaction below the stipulated percentage, the contractor shall adopt proper techniques as directed by the Engineer in-Charge and to his satisfaction to ensure the specified degree of compaction. The cost of tests to be performed shall be borne by the Contractor. During the execution of work, natural drainage of the area shall be maintained by the contractor.

3.3.3 Dewatering

If water is met with in the excavation due to stream flows, springs, seepage, rain or other causes, it shall be removed by suitable diversions, pumping or bailing out and other excavation kept dry whenever so required or directed by the Engineer-in-Charge, Care shall be taken to

so discharge the drained water as not to cause damage to the works, crops or any other property. No extra payment shall be admissible to the contractor on this account.

3.3.4 Disposal of excavated Materials

All the excavated materials shall be the property of Customer. Where the excavated material is directed to be used in the filling area, it shall be directly deposited at the required location complying with the total requirements. All disposed material other than hard material shall be spread in layers at the places within specified leads. All hard materials, such as hard moorum, rubble, etc., not intended for use in the filling, shall be stacked neatly on Corporation land as directed by the Engineer-in-Charge within the lead specified for the item, for future use such as pitching. Unsuitable and surplus materials not intended for use in any part of the works shall be disposed of as directed by the Engineer-in-Charge.

3.3.5 Plying of Construction Traffic

Construction traffic shall not use the levelled area without prior permission of the Engineer-in-Charge. Any damage arising out of such use shall be made good by the Contractor at his own expense.

3.3.6 Preservation of Property

The Contractor shall undertake all reasonable precautions for the protection and preservation of any or all existing roadside trees, drains, sewers or other subsurface drains, pipes, conduits and any other structures under or above ground, which may be affected by construction operations and which in the opinion of the Engineer-in-Charge shall be continued in use without any change. Safeguards taken by the Contractor in this respect, shall be got approved by him from the Engineer-in-Charge. However, if any of these objects is damaged by reason of the Contractor's negligence, it shall be replaced or restored to the original condition at his expense.

3.3.7 Finishing Operations

Finishing operations shall include the work of properly shaping and dressing all excavated surfaces. When completed, no point on the slopes shall vary from the designated slopes by more than 150 mm measured at right angles to the slope, except where excavation is in rock where no point shall vary more than 600 mm from the designated slope. In no case shall any portion of the slope encroach on the road way.

3.4 Earth Fill

3.4.1 Suitable Material

The borrowed earth used in filling shall be free from all roots, grass, shrubs, rank vegetation, brush wood, tree sapling and rubbish.

3.4.2 Unsuitable Material

Unsuitable material shall mean materials unsuitable for placing as fill in the works and shall comprise:

- (1) Material from swamps, marshes and bogs;
- (2) Peat, logs, stumps and perishable materials;
- (3) Material susceptible to spontaneous combustion;

- (4) Any natural material or industrial and domestic produce which will adversely affect other materials in the work;
- (5) Clay with liquid limit exceeding 80% and/or plasticity index exceeding 557o.

3.4.3 Spreading and Compaction of Filling

For the earth works contractor shall satisfy the Engineer-in-Charge that the entire specified requirement regarding compaction can be achieved. The Final formation shall be correct in level and profile after compaction. In the case of earth work consolidated under optimum moisture conditions, each layer of earth shall be carefully moistened to give field moisture content of about + 1% to - 2% of the optimum moisture content (OMC). The OMC shall be determined according to IS: 2720 (Pt.VII &VIII) Methods of Tests for Soils. Each layer shall then be compacted by rolling with wooden/ steel rammer or movement of dozers, trucks, 8/10 tonnes power road roller, sheep foot roller and vibratory compactors. The required amount of water shall be added during consolidation to keep the moisture content of the soil at the optimum as per test. The density to be achieved for each layer of the material shall not be less than 95% of the density obtained in the laboratory (Proctor Method).

Control on compaction in the field shall be exercised through frequent moisture content and density determinations. A systematic record of these shall be maintained. At all times during construction the top of the embankment shall be maintained at such cross fall as will shed water and prevent pounding.

3.6 Testing shall be carried out as per field quality plan.

3.7 Measurement for Payment.

The ground levels shall be taken at every 5 metres distance and at closer distances where pits, undulations, etc. are met with. The ground level shall be recorded in field book, plotted on plans and shall be signed by contractor and the Engineer-in-Charge before the earth work is started. The levels of the area after excavation shall be recorded in the field book duly signed by the Engineer-in-Charge and contractor. The labour, materials, tools, equipment, safeguards and incidentals required for taking levels shall be supplied by the contractor at his own cost.

In case of filling with borrowed earth, the measurement shall be based on levels of area under filling only.

3.7.1 Earth work in Excavation and filling

The quantity of excavation in all types of soil and soft/disintegrated rock shall be worked out by using initial and final levels. No void deduction shall be made to calculate net quantity of earth work. Only Excavation/cutting will be measured for payment purpose. The unit of measurement shall be in cubic metre.

The unit rate shall include all lifts and all leads within levelling boundary. It also includes disposal of surplus earth and stacking of unusable material up the lead of 2000 meters beyond the levelling boundary

3.7.2 Earth work in excavation in all types of Soils and Soft /disintegrated rocks, Hard Rocks and disposal

Quantity of excavation in all type of soils and soft/disintegrated rocks shall be worked out based on initial level before start of excavation and final levels after excavation. No void deduction shall be made to calculate net quantity of earth work in excavation. The excavated soil and soft/disintegrated rock shall be used for filling in lower areas of the substation. The

unit rate shall include disposal of excavated material for leads up to 2000 meters beyond the levelling boundary.

For hard rock excavation, the volume of hard rock shall be computed on the basis of stacks of excavated rubble after making 50 per cent deduction for voids. The unit of measurement shall be in cubic meter. The unit rate shall include stacking, disposal of excavated material for leads up to 2000 meters beyond the levelling boundary.

Where soil, soft/disintegrated rock and hard rock are mixed, The quantity of earth work in excavation in all kinds of soil & soft/disintegrated rock shall be arrived by reducing quantity of hard rock from the gross excavated quantity.

3.7.3 Filling using earth borrowed from outside the substation land

The quantity of earth shall be worked out based on initial and final levels of levelling area. No void deduction shall be made to calculate net quantity of earth work. The unit of measurement shall be in cubic meter. The rate shall include arrangement of borrow area, payment of royalty, transportation, laying compaction, all leads and lifts etc.

3.8 Rate:

Rate for each item shall include all operations specified in the respective clause of technical specification of Site Levelling Work, Section Project and work mentioned in BOQ item.

B.) DRAIN

The construction drawing for the section of drain is enclosed with the tender documents.

C.) ROAD

The construction drawing for the section of Road is enclosed with the tender documents.



TRANSMISSION BUSINESS GROUP (Subcontracts Management)

Doc. No. TBSM/Std-Spec/Cov-Str/01

Rev. 02

SPECIFICATION FOR COVERED STORE FOR SWITCHYARD

1. The covered store shall be constructed of adequately designed steel columns and tubular trusses (span 10m) placed at an interval of 5.00m centre to centre with suitable purlins and runners provided to support the roofing & cladding. The length of the store shall be 25.00/20.00/15.00/10.00m depending on the requirement as indicated in the BOQ. The store of the length 25.00/20.00/15.00/10.00m shall be termed as D/C/B/A type respectively.
2. The roofing and side cladding shall be of GS corrugated sheets (0.8mm thick) fixed to purlins & runners with suitable polymer/GI coated J or L hooks, bolts and nuts 8 mm diameter with bitumen and G.I. Limpet washers or with G.I limpet washers filled with white lead and including a coat of approved steel primer and two coats of approved paint on overlapping of sheets complete (up to a pitch of 60 degrees). The roof shall be made with proper arrangements to prevent water leakage.
3. The bottom of the truss shall be 5.00m. above FFL (Finished floor level).
4. The steel columns shall be supported on concrete pedestals & footings with foundation / anchor bolts. The following minimum requirements shall be ensured-
 - Depth of footing below existing ground level = 1.00m
 - Size of footing = 1.50m X 1.50m
 - Depth of footing = 0.30m
 - Reinforcement in footing = 12dia @ 150 c/c both ways, top & bottom.
 - Size of pedestal = 0.50m X 0.50m
 - Reinforcement in pedestal – Longitudinal = 8 Nos 16dia
- Ties = 8dia @ 200c/c
5. 230mm thick brick walls in cement mortar 1:6 shall be provided all along the periphery and shall be 1.50m above the FFL except for D-type Store which have two parts. Part with sitting space for site officials will have wall height of 3.30m above FFL on all sides while the part with store rack arrangement will have wall height of 1.50m above FFL. Columns for Rolling Shutter will be encased with work upto FFL+5.00m. All brick-wall shall rest on suitable brick masonry foundation which shall extend to minimum 600mm below the FFL. 12/15mm plaster in cement mortar 1:6 shall be provided on the walls which shall be finally painted with 3 coats of colour-wash.
6. The floor of the store shall be made with 100mm thick PCC 1:4:8 with 20mm down aggregate neatly finished and laid over 150mm thick boulder soling with interstices filled with suitable material. The boulder soling shall be laid over well compacted earth.

The earth left-out after backfilling in the foundations shall be spread, watered & well compacted over NGL/FGL in the store floor area. Additional earth required for filling & compaction in the store floor area shall be excavated & transported from the switchyard area as per instruction of the Engineer-in-charge.

7. The store shall be provided with a 5.00m wide X 5.00m high lockable, electrically operated with handle arrangement for manual operation & painted rolling shutter with all accessories, as required. In addition, in all type of stores except D-type store, painted steel ventilators of size 1.20m wide X 0.50m high shall be provided between each span and along both longitudinal directions and at a height of 4 Mts above FFL. The ventilator frame shall be fabricated & fixed by welding to adjoining Girt / Truss members using MS Angle L25x25x3. 8mm square MS bars shall be welded @200mm c/c horizontally & vertically with L25x25x3 forming a mesh in the ventilators and 4mm thick glass panes shall be fixed with putty & glazing clips in the ventilator frame. In front of the rolling shutter, suitable ramp shall be provided for material entry.
8. In D-type store, in the part with sitting space for site official, in addition to ventilators, 4 nos. painted steel windows of size 1.20m wide X 1.20m high shall be provided with lintel at 2.10m above FFL. The windows frame shall be fabricated & fixed into brick wall using MS Angle L25x25x3. 8mm square MS bars shall be welded @100mm c/c horizontally & vertically with MS L25x25x3 forming a mesh in the windows and 4mm thick glass panes shall be fixed with putty & glazing clips in the window frame. This part will have 03 nos doors and false ceiling. 02 doors will have size 2.1m (high) x 1.0m (wide) and 01 no door for bath room will have size 2.1m (high) x 0.75m (wide). The door frames shall be of MS Angle L35x35x5 and it will be suitably fixed with brick wall while the door shutter frames shall be of MS Angle L35x35x3 and shutter will be Pre-laminated flat pressed 3-layer (medium density) particle board or graded wood particle board IS:3087 marked, with one side decorative and other side balancing lamination Grade I, Type II exterior grade IS:12823 marked. Particle board will be suitably fixed with the shutter frame of the doors. All doors will have ISI marked M.S. sliding door bolts with nuts & screws (250x16mm), ISI marked M.S. tower bolts (barrel type) with screws (250x10mm) and ISI marked M.S. door handles with screws (125mm).
9. The part with sitting space for site official of D-type store will have 12.5 mm thick tapered edge gypsum plain board false ceiling conforming to IS:2095- Part I. Height of false ceiling will be 3.2m above FFL. False ceiling will be fixed with suitable frame work made of special sections, power pressed from M.S. sheets and galvanized with zinc coating of 120 gms/sqm (both side inclusive) as per IS:277 and consisting of angle cleats of size suitable size, dash fasteners, G.I. Channels, connecting clips, rawl plugs, etc. all complete. Detailing will be done at the site as per site suitability.
10. Adequate no. of fire extinguishers (min. 4 nos. CO₂ and 2 nos. foam type) and Fire Buckets (02 nos for sand & 02 nos water) with stand shall be provided in the store area. Minimum capacity of CO₂ type fire extinguisher shall be 3kg and of Foam type fire extinguisher shall be 9 litre.

11. Depending upon the size of the store, illumination arrangements shall be made inside the store - comprising of min. of 8/6/4 tube lights (20W) incl fittings respectively and a 15Amp. power socket and suitable switchboard at the entrance to the stores. The switch board shall also serve as the controlling point for illumination of open store yard. 2.5mm copper wire will be provided for power, for tube lights & open yard lighting.
12. The part with sitting space for site official of D-type store will have, in addition to above mentioned at S. No. 11, 6 nos. 20W 4feet tube-lights with point wiring, 4 nos. 1200 Sweep Reputed Make Fan with Regulator with point wiring, 5 nos 16A switch socket board equally distributed in office area, 3 nos 32A receptacle with MCB for Air Conditioning System with 4 sqmm copper wiring equally distributed and point wiring including complete scope switch, socket, conduit, 4sqmm & 2.5mm copper wire for power & fan, 1.5sqmm copper wire for tube lights. Conduit pipe shall be provided for electrical wiring in the part with sitting space for site official of D-type store.
13. D-type store will have a toilet arrangement inside and septic tank & soak pit outside. Inner size of the toilet will be 2.4m x1.5m and it will have a Wash Basin (WB), European Water Closet (EWC) & wall mounted mirror inside. Size of the septic tank will be 2.00m x 0.90m & will have the liquid depth of 1.40m all complete as per standard design given in CPWD Specification Vol-2 Fig. 19.15. The soak pit will be of size 1.20x1.20x1.20 m filled with brickbats all complete as per standard design given in CPWD Specification Vol-2 Cl. 19.11. Connections of the EWC & WB with Septic Tank and of Septic Tank with Soak pit will be done using S.W. drain pipe 100 mm diameter.
14. D-type store will have 500-liter polyethylene water storage tank, IS:12701 marked, with cover and suitable locking arrangement place on 3.0m high framed steel stand outside. Vertical members of the stand will be of ISA 65x65x6 horizontally braced with ISA 45x45x5 with top horizontal members of ISA 45x45x5. Main vertical members will suitably be grouted in 0.6x0.6x0.6 concrete block (1:2:4) in the ground. The water storage tank will be connected with the WB & EWC using CPVC pipes of dia 20mm & 15mm. PTMT Bib cock & stop cock of nominal bore 15 mm will be provided in WB, EWC, near water storage tank & wherever required. 8 mm dia C.P. / S.S. Jet with flexible tube upto 1 metre long with S.S. triangular plate to EWC of quality and make as approved by Engineer - in - charge will also be provided and fixed.
15. Providing of incomer cable and giving supply to the switchboard is NOT in the scope of store construction.
16. Any other item/work, if required to be done for the completion of the store, is deemed to be included in the rate.
17. All materials shall conform to IS and shall be procured from approved sources & reputed manufacturer(s). The execution of work shall be as per latest CPWD/IS specifications & directions of Engineer-in-Charge.



TRANSMISSION BUSINESS GROUP (Subcontracts Management)

Doc. No. TBSM/Std-Spec/Open-Str/02

Rev. 02

SPECIFICATION FOR OPEN STORE FOR SWITCHYARD

1. The area of the open store shall be as indicated in the BOQ.
2. The area identified for the open store shall be enclosed with barbed wire fencing-1.8 M high above ground level with 8 strands of horizontal and two diagonal barbed wires (between 2 posts). The posts shall be of medium M.S tubes of 50mm dia or angle 50x50x6 and shall be spaced 2.5m centre to centre. Inclined post supports shall be provided at all corners and at every 10th post. All posts shall be embedded at least 0.4m in PCC 1:2:4 block of size 0.40x0.40x0.6m deep. 75mm thick PCC 1:4:8 shall be provided below concrete block.
3. One 5m wide X 1.8m high (2 leaf) gate suitable for truck/ trailer entry and one 1m wide X 1.8m high wicket gate suitable for personnel entry shall be provided. The gate shall be of pipe framework (having suitable stiffness) with welded mesh suitably fixed on it. The gate shall be provided with suitable locking arrangement.
4. The area of the open store shall be raised minimum 150mm above the surrounding ground level with compacted earth. Over this, flat brick soling or some other suitable alternative material of minimum thickness 75mm shall be provided.
5. One central road 3.75 m wide located centrally along the long axis of the stores shall be constructed with 150mm compacted thickness boulder soling interstices filled with moorum/binding material and adequately rolled and compacted. The top of the road shall be 150mm above the store soling level. The total area of the road shall be maximum 15% of the area of the open store.
18. One security cabin of size 2.0m x 2.0m shall be provided inside the fence adjacent to the gate. Adequate no. of fire extinguishers (min. 4 nos. CO₂ and 2 nos. foam type) and fire bucket (02 nos for sand & 02 nos water) with stand shall be provided adjacent to the cabin. Minimum capacity of CO₂ type fire extinguisher shall be 3kg and of Foam type fire extinguisher shall be 9 litre.
6. The area shall be adequately illuminated with min. 4 nos. of halogen lamps at the four corners of the stores and 1 tube light in the security cabin. The scope includes cabling from the main switch in the covered stores and interconnected cabling. Where the scope includes only the open store, the main switch shall be provided inside the security cabin.
7. All materials shall conform to IS and shall be procured from approved sources & reputed manufacturer(s). The execution of work shall be as per latest CPWD/IS specifications & directions of Engineer-in-Charge.

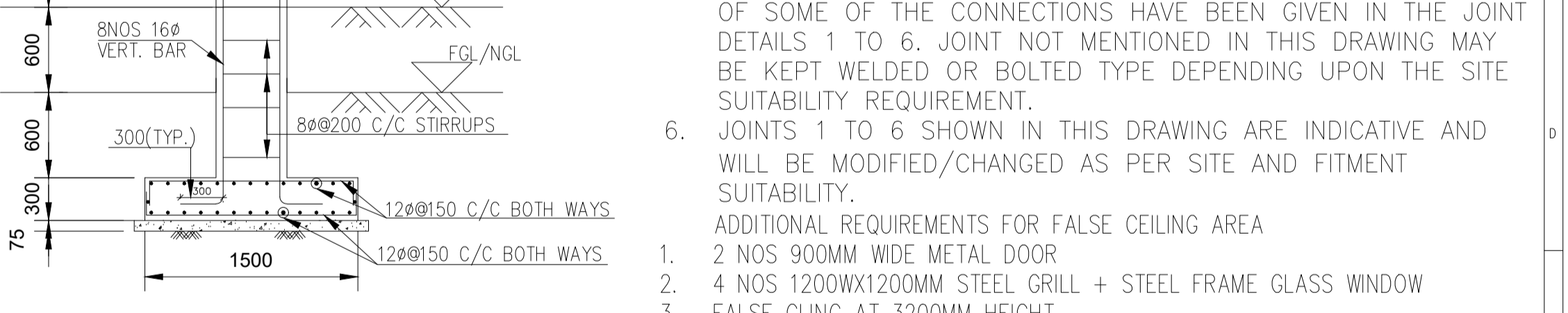
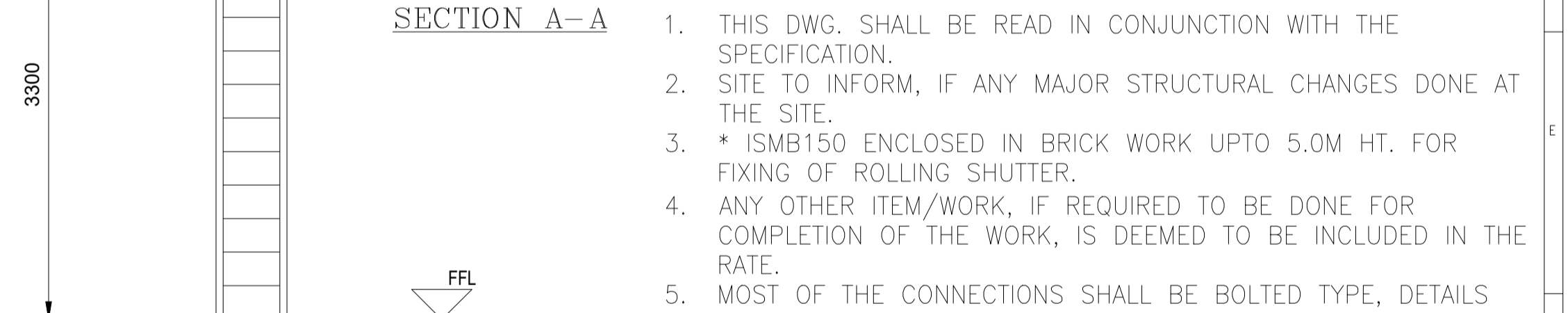
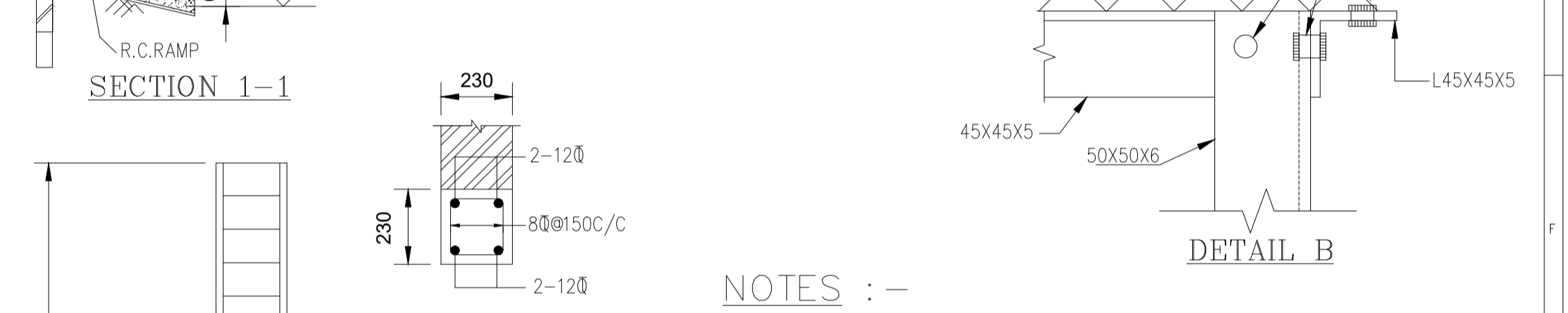
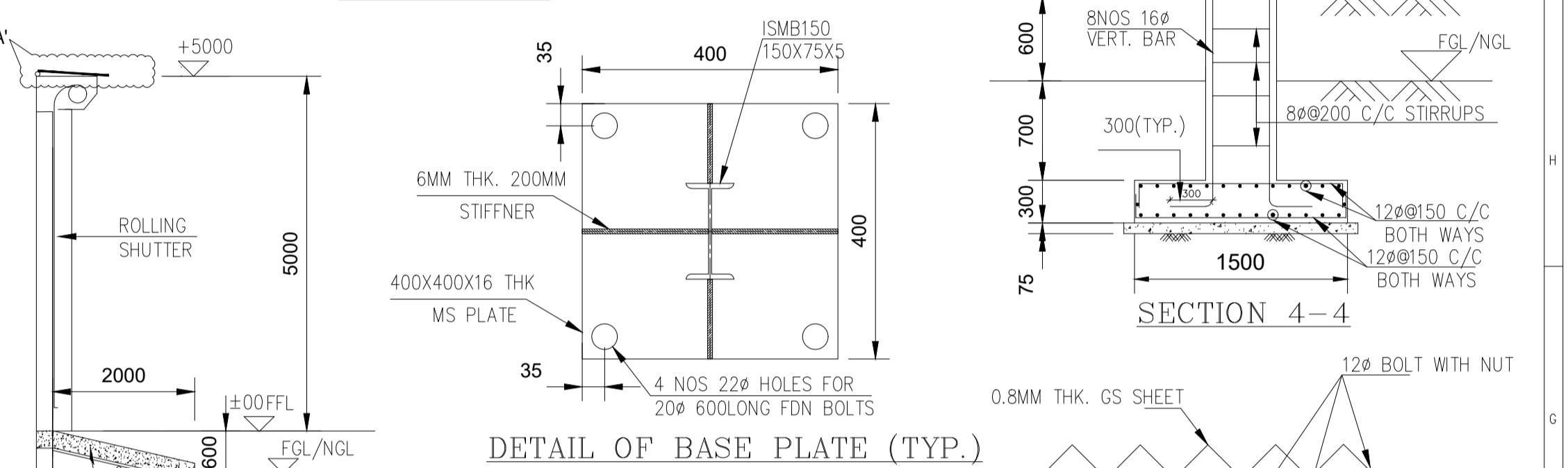
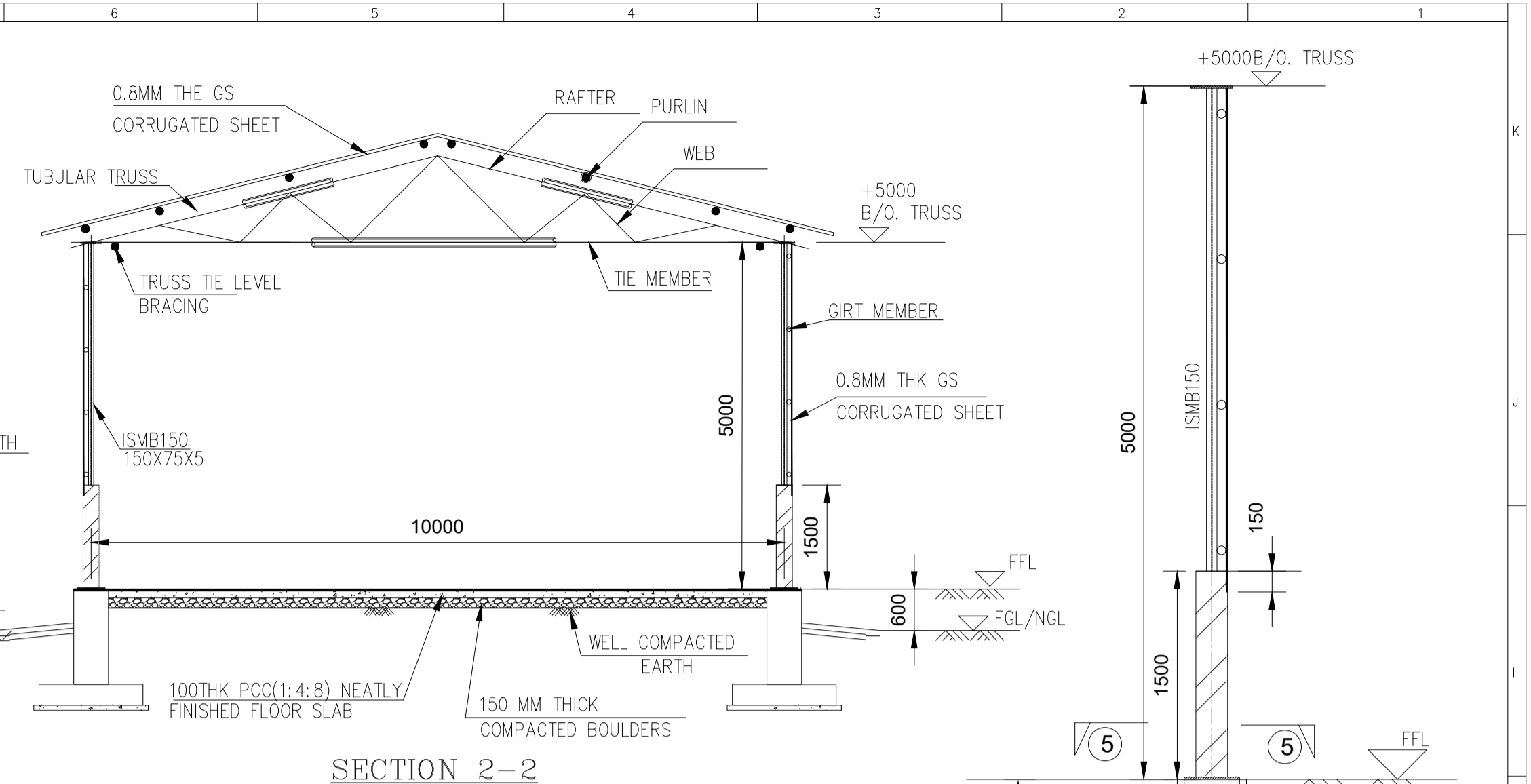
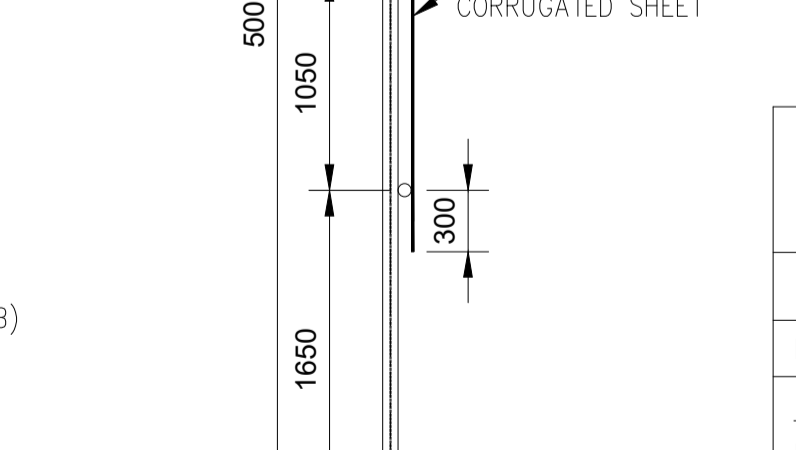
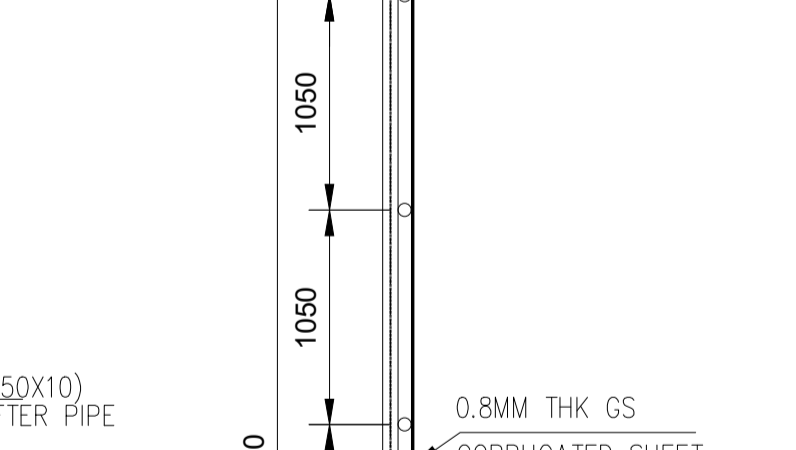
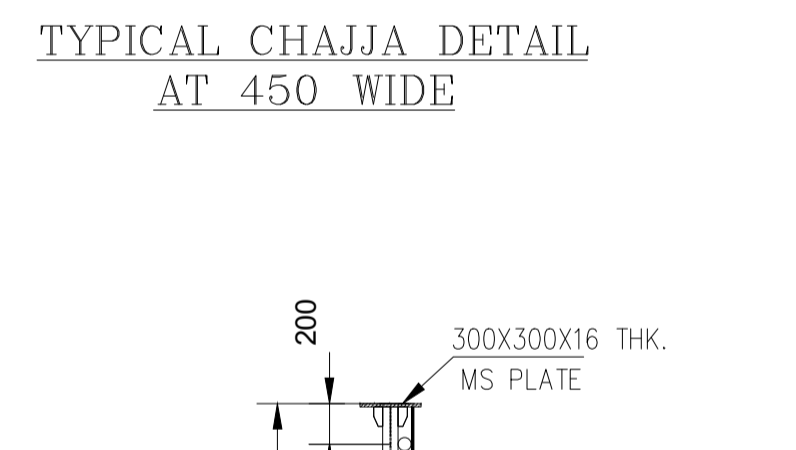
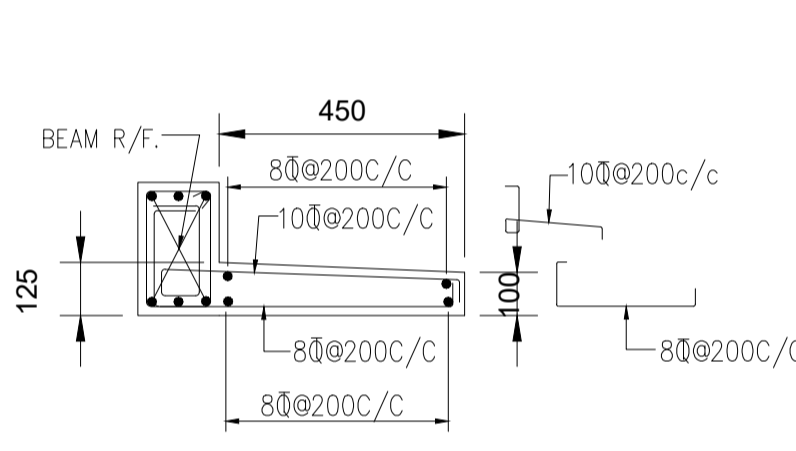
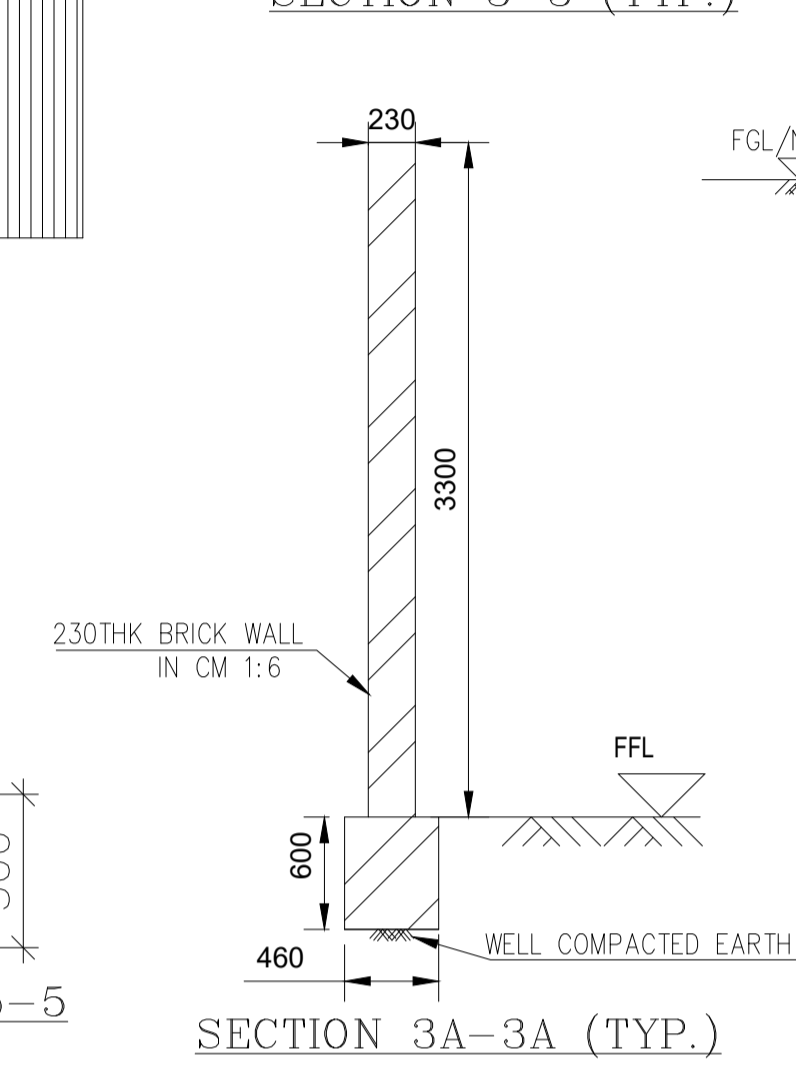
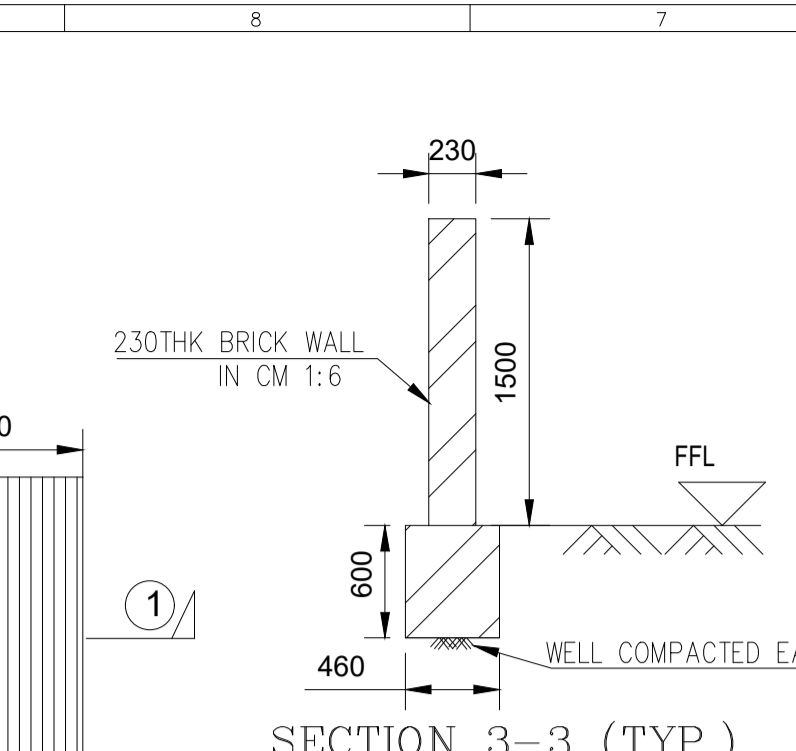
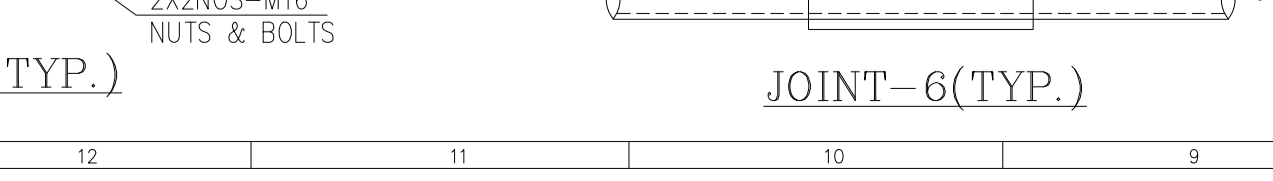
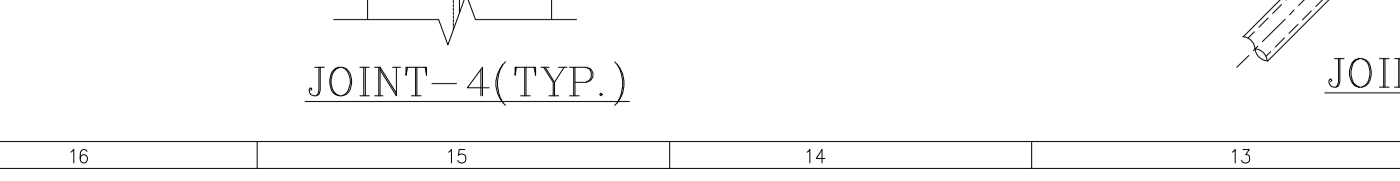
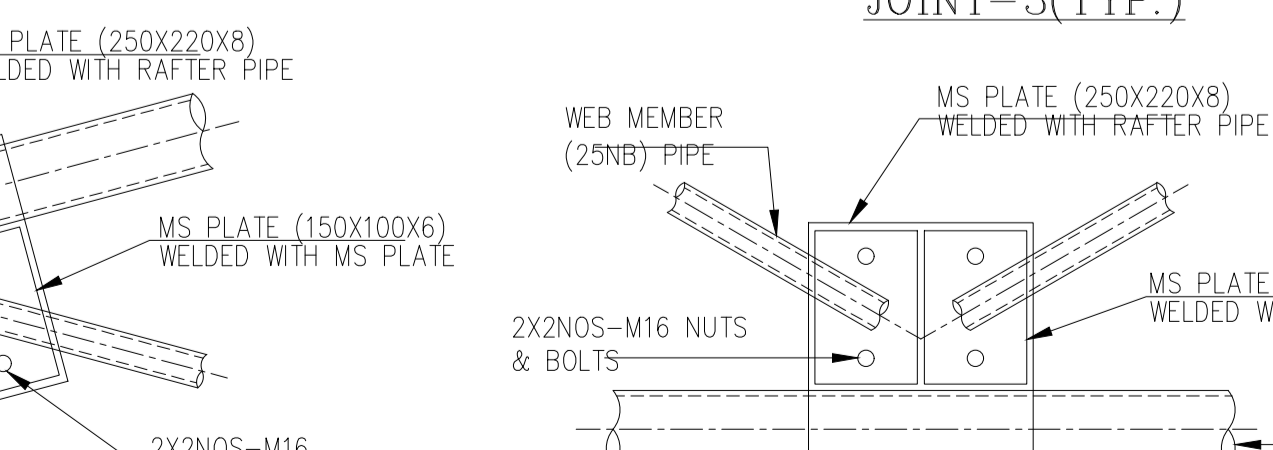
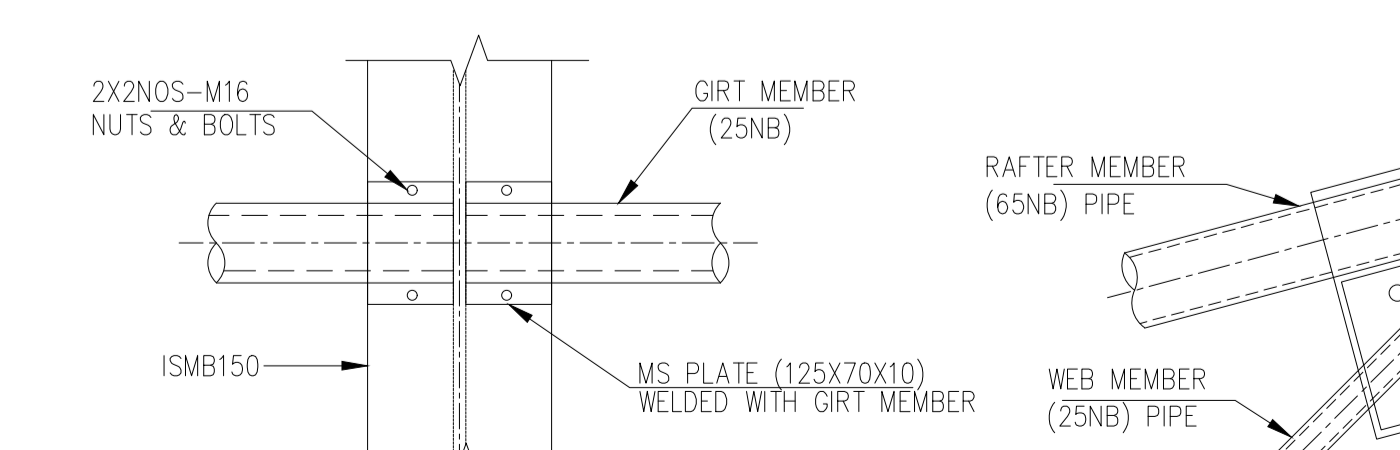
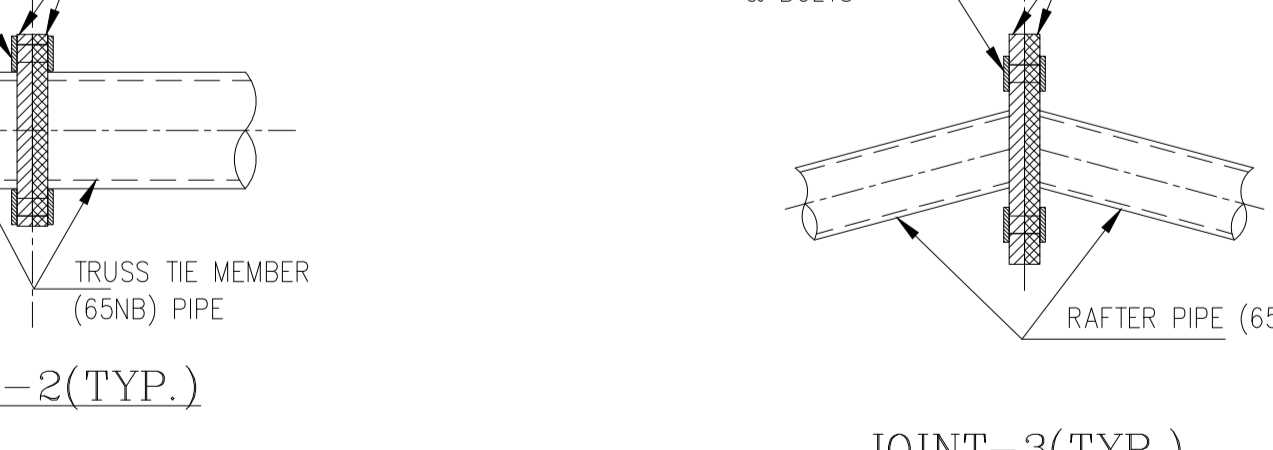
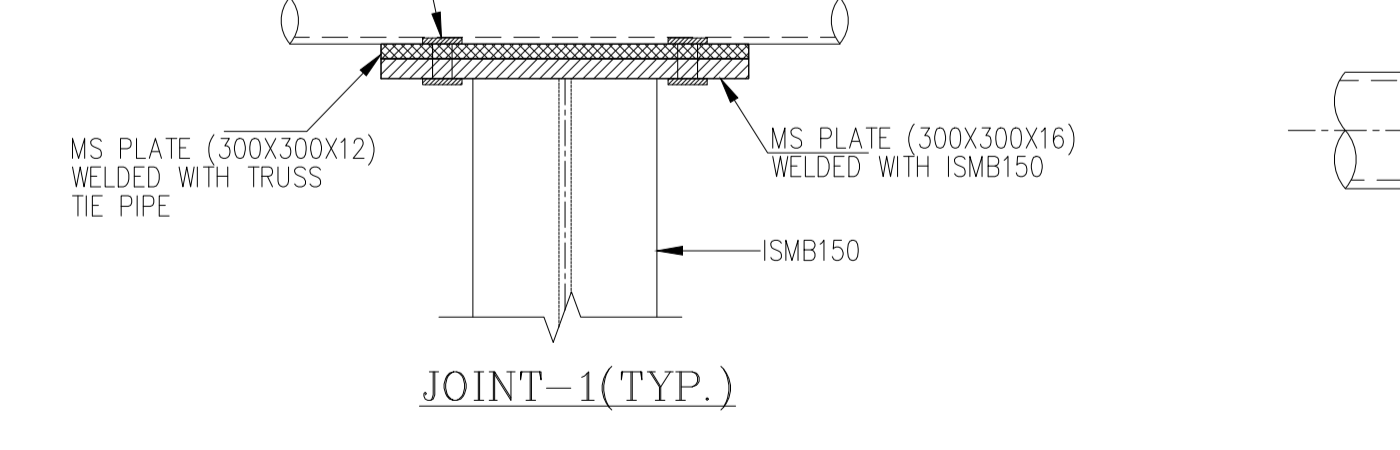
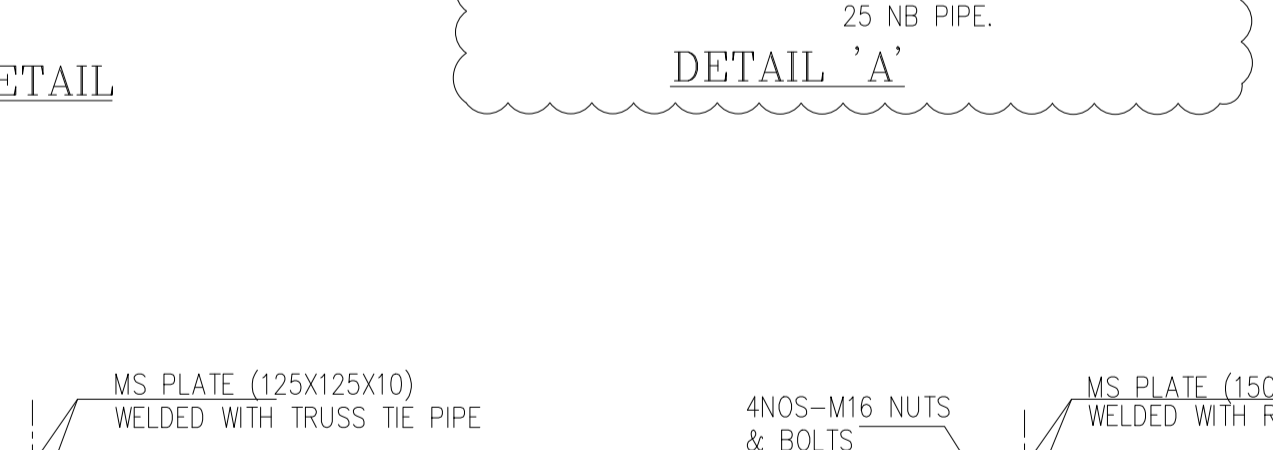
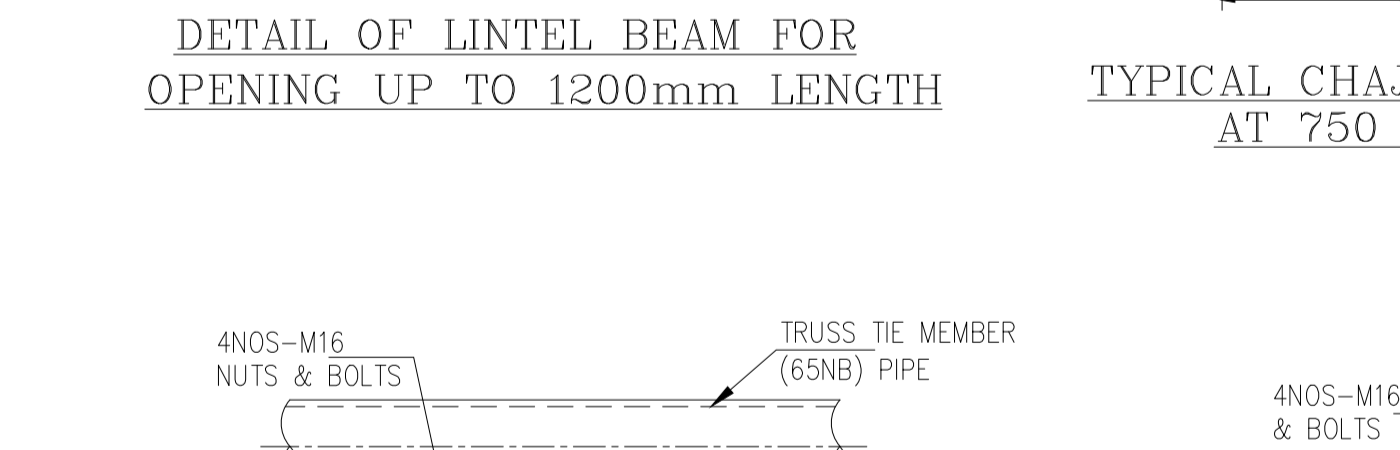
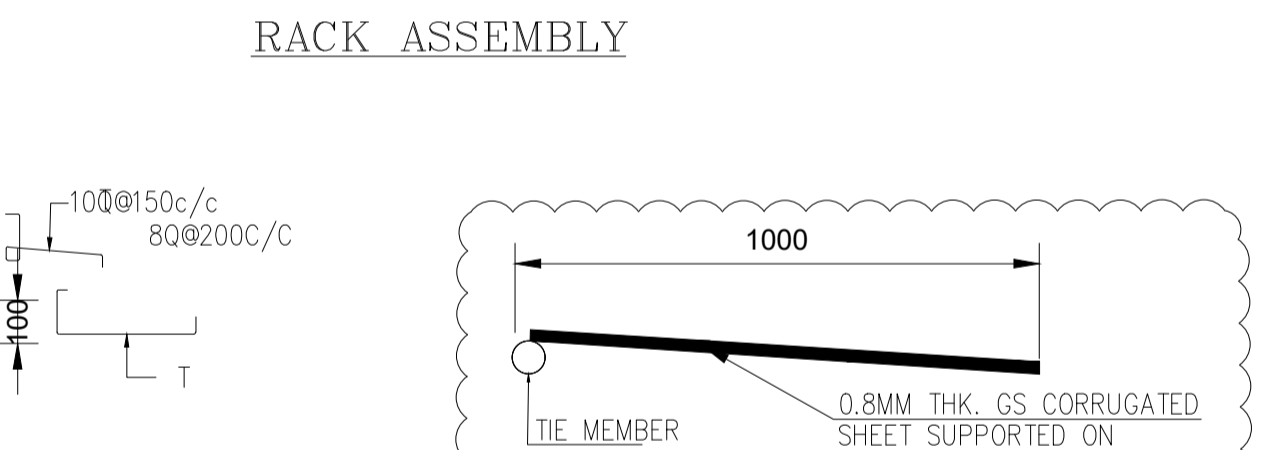
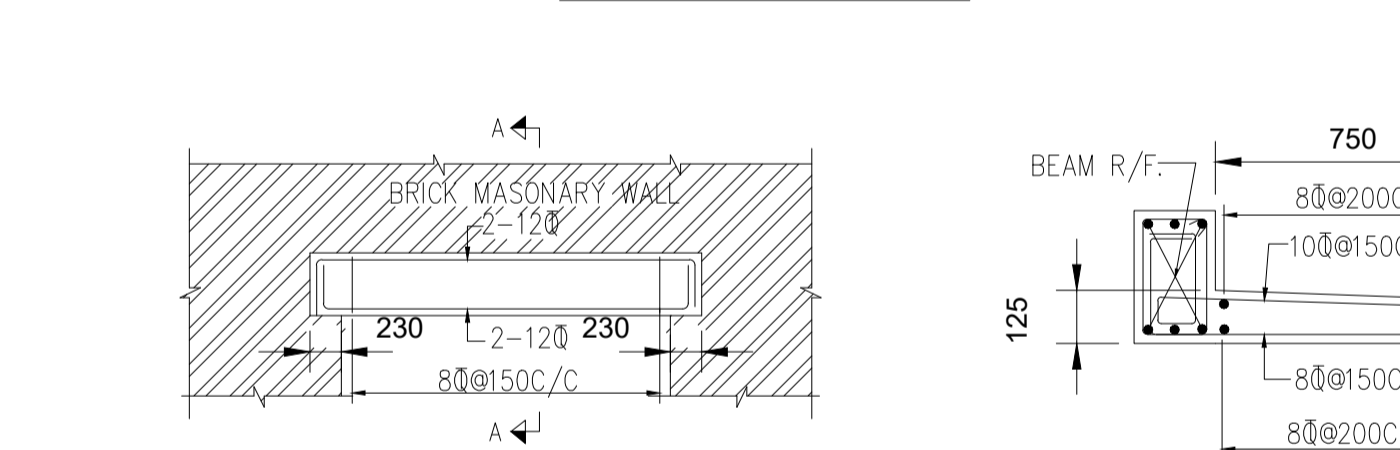
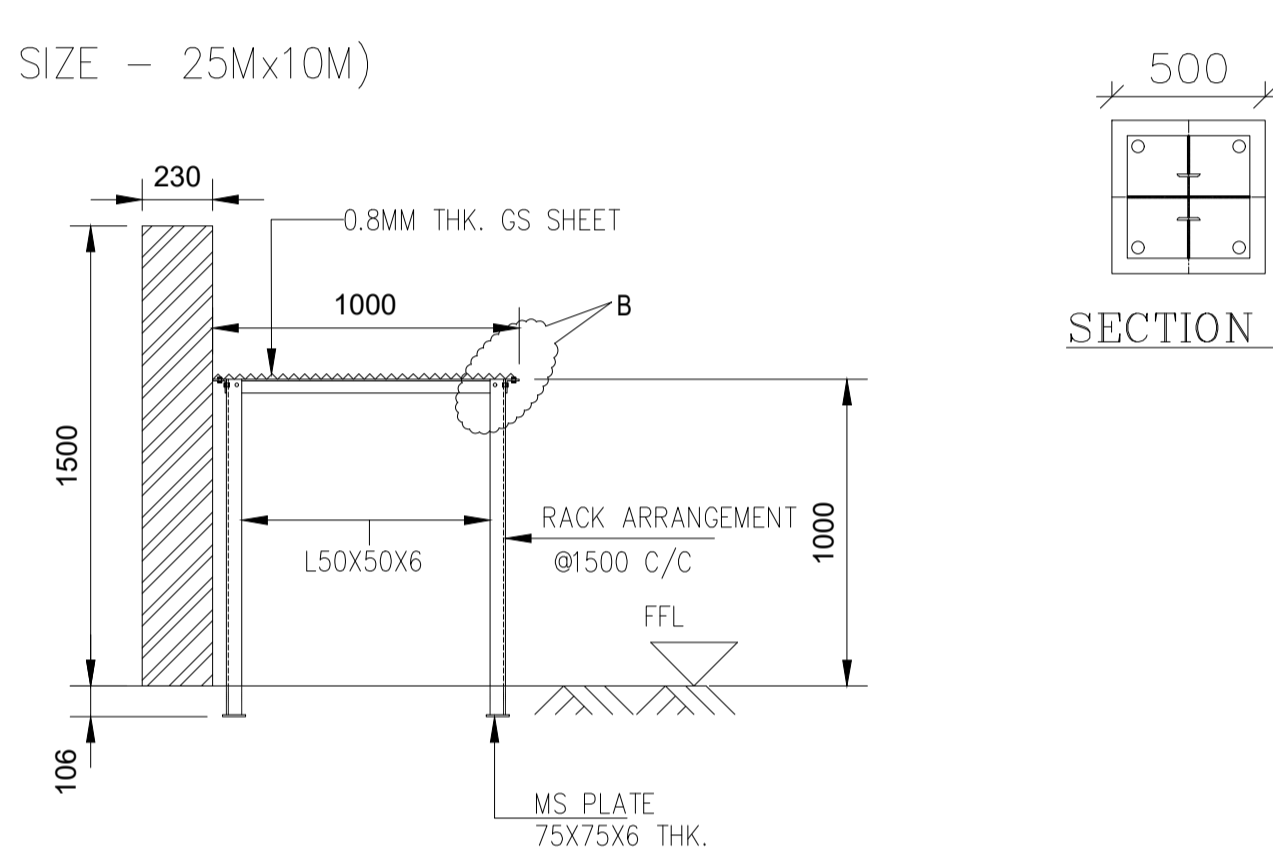
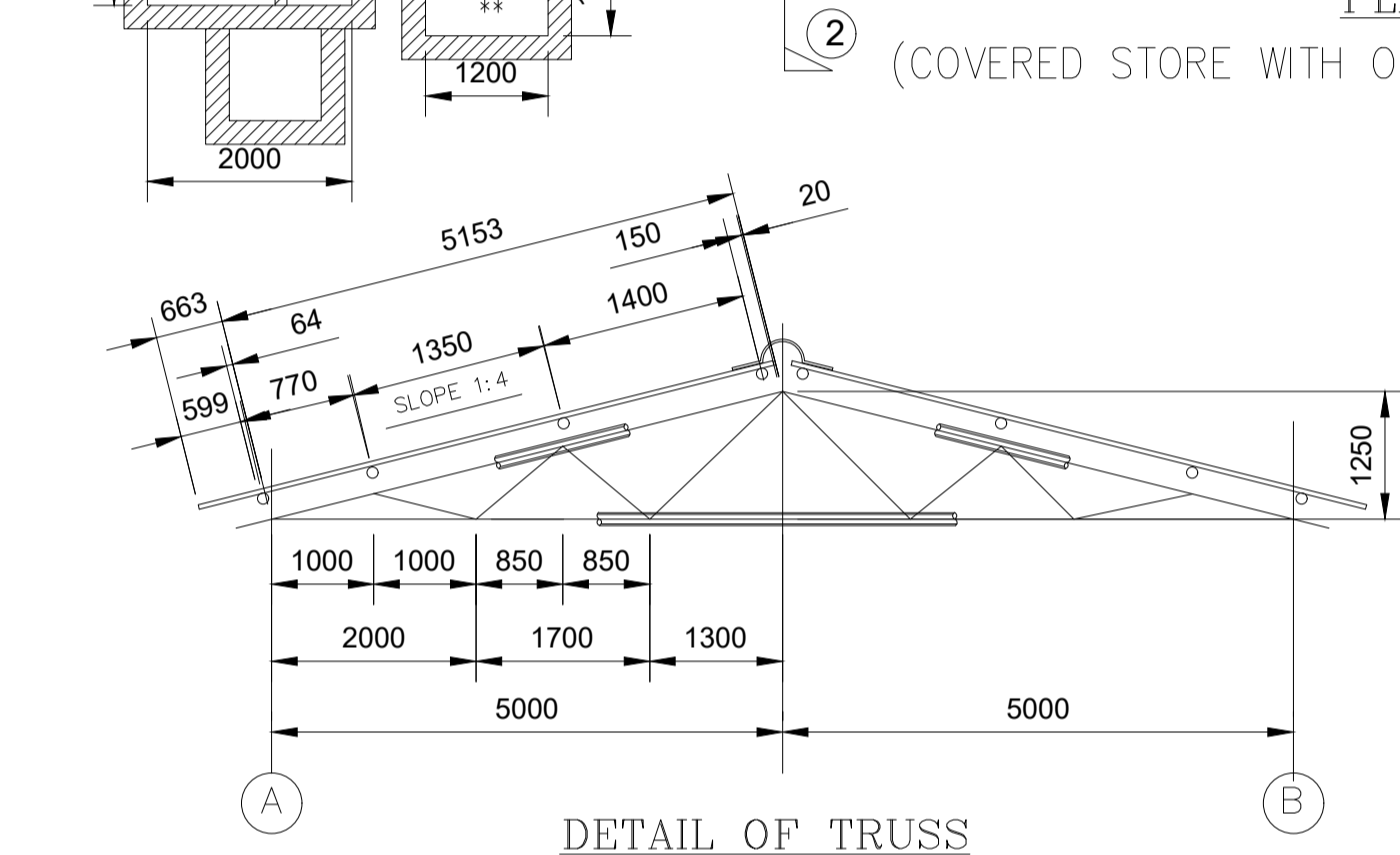
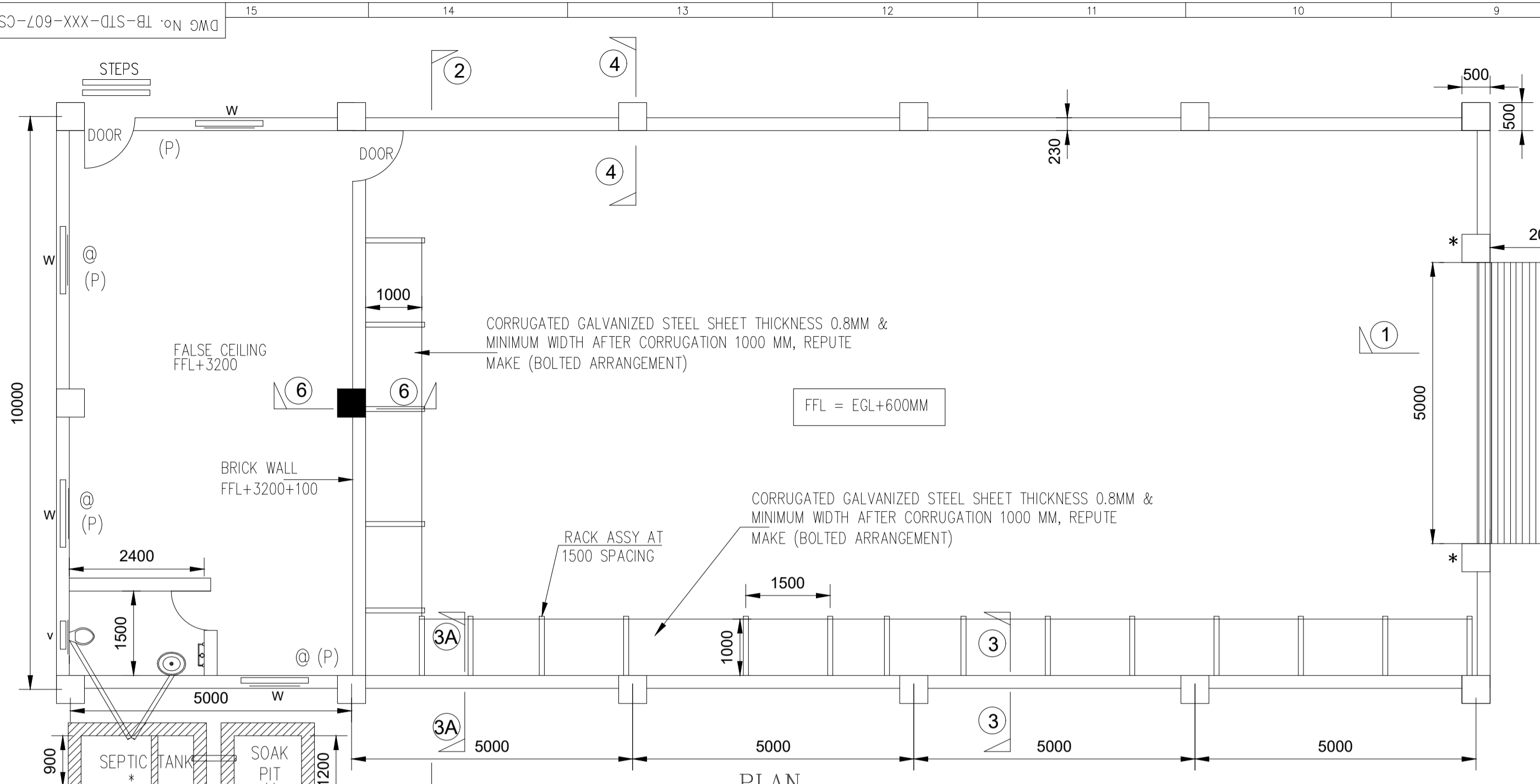

ITEM/MEMBER	SECTION
PURLIN	65 NB PIPE (MED.)
TRUSS	
RAFTER (TOP CHORD)	65 NB PIPE(MED)
TIE MEMBER (BOT. CHORD)	65 NB PIPE(MED)
DIAGONALS (WEB)	25 NB PIPE(MED)
TRUSS TIE LEVEL BRG.	32 NB PIPE(MED)
GIRT MEMBER	25 NB PIPE(MED.)

NOTES :-

- THIS DWG. SHALL BE READ IN CONJUNCTION WITH THE SPECIFICATION.
- SITE TO INFORM, IF ANY MAJOR STRUCTURAL CHANGES DONE AT THE SITE.
- * ISMB150 ENCLOSED IN BRICK WORK UPTO 5.0M HT. FOR FIXING OF ROLLING SHUTTER.
- ANY OTHER ITEM/WORK, IF REQUIRED TO BE DONE FOR COMPLETION OF THE WORK, IS DEEMED TO BE INCLUDED IN THE RATE.
- MOST OF THE CONNECTIONS SHALL BE BOLTED TYPE, DETAILS OF SOME OF THE CONNECTIONS HAVE BEEN GIVEN IN THE JOINT DETAILS 1 TO 6. JOINT NOT MENTIONED IN THIS DRAWING MAY BE KEPT WELDED OR BOLTED TYPE DEPENDING UPON THE SITE SUITABILITY REQUIREMENT.
- JOINTS 1 TO 6 SHOWN IN THIS DRAWING ARE INDICATIVE AND WILL BE MODIFIED/CHANGED AS PER SITE AND FITMENT SUITABILITY.

ADDITIONAL REQUIREMENTS FOR FALSE CEILING AREA

- 2 NOS 900MM WIDE METAL DOOR
- 4 NOS 1200WX1200MM STEEL GRILL + STEEL FRAME GLASS WINDOW
- FALSE CLING AT 3200MM HEIGHT
- 6 NUMBERS 18W 4 FEET TUBE LIGHTS WITH POINT WIRING
- 4 NUMBER 1200 SWEEP REPUTED MAKE FAN, REGULATOR WITH POINT WIRING
- (P) 5 NUMBERS 16A SWITCH SOCKET BOARD, EQUALLY DISTRIBUTED AMONG OFFICE AREA
- @ 3 NUMBERS 32A RECEPTACLE WITH MCB FOR AIR CONDITIONING SYSTEM WITH 4 SQ MM COPPER WIRING, EQUALLY DISTRIBUTED.
- POINT WIRING INCLUDING COMPLETE SCOPE SWITCH, SOCKET, CONDUIT, 4 SQMM, 2.5MM COPPER WIRE FOR POWER & FAN. 1.5 SQMM COPPER WIRE FOR TUBE LIGHT

* SEPTIC TANK AS PER CPWD SPEC FIG. 19.15
 ** SOAK PIT AS PER CPWD SPEC CL. 19.11 & DSR 2016 ITEM NO. 19.33

REV.	DATE	ALTERED	CHECKED	APPROVED	REV.	DATE	ALTERED	CHECKED	APPROVED

भारत हेवी इलेक्ट्रिकल्स लिमिटेड
 भारत हेवी इलेक्ट्रिकल्स लिमिटेड
 भारतीय भारी विद्युत परियोजना विभाग
भारत हेवी इलेक्ट्रिकल्स लिमिटेड
 TRANSMISSION PROJECTS DIVISION

ड्राइंग/DEPT.	GS	हस्ता/./SIGN.	-SD-	दि./DATE	18/10/24
ड्राइंग/DEPT.	SV/K	हस्ता/./SIGN.	-SD-	दि./DATE	18/10/24
ड्राइंग/DEPT.	PLK/VK	हस्ता/./SIGN.	-SD-	दि./DATE	18/10/24

अनुपात / SCALE: 1:1
 कार्ड कोड / CARD CODE: 00
 ड्राइंग/DEPT. GA PLAN, SECTION & DETAILS OF COVERED STORE WITH PARTITION (STANDARD DRAWING)
 ड्राइंग/DEPT. TB-STD-XXX-607-CS_D
 पृष्ठ नं./SHEET No. 01 / अगला पृष्ठ/NEXT SHEET

COMPUTER DRG PARTI NAM: ...
 SIGN & DATE REF. DRG. NO. ...
 INVENTORY No. ...

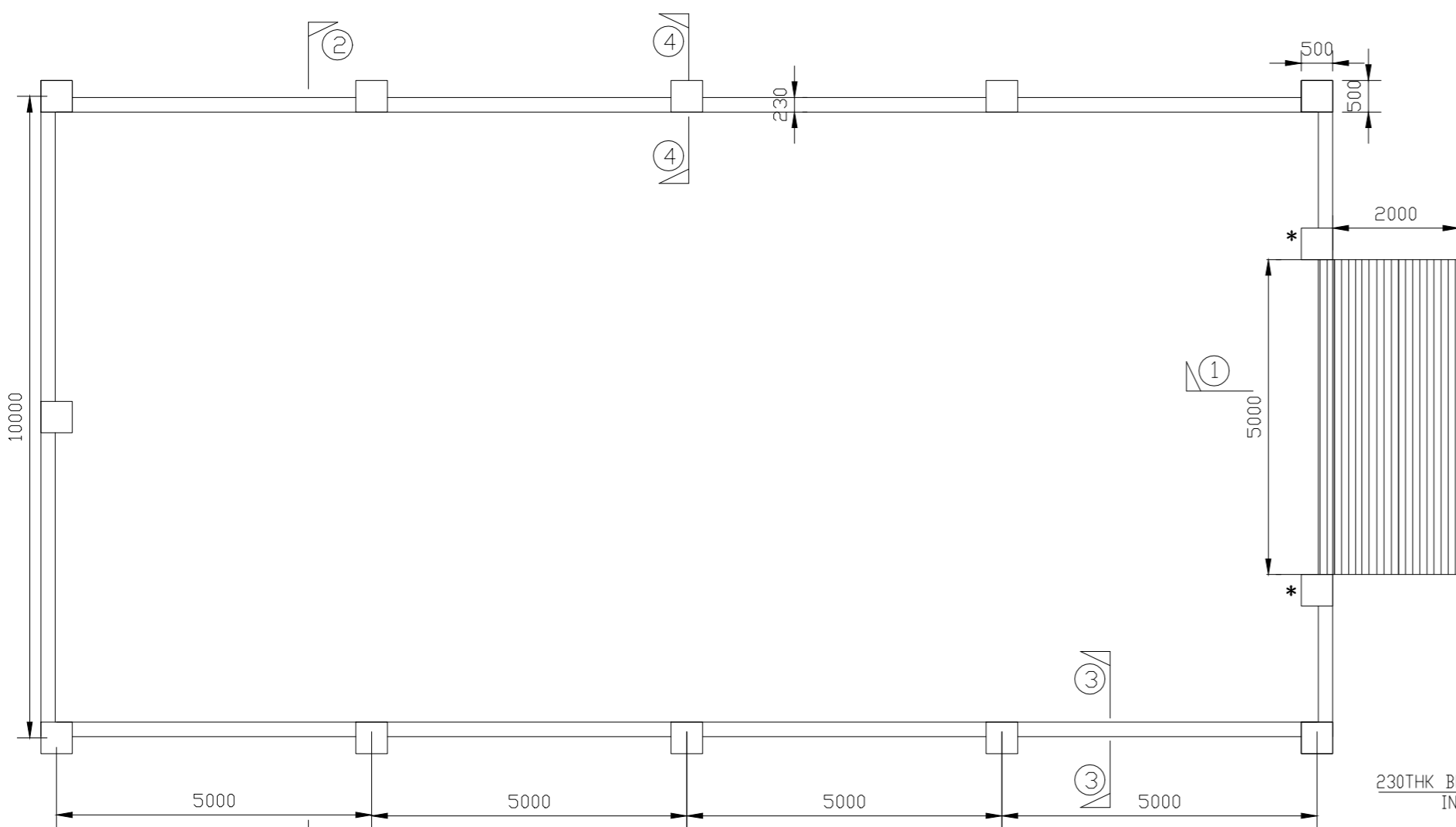

PLAN

(SIZE - C: 20Mx10M, B: 15Mx10M & A: 10Mx10M)

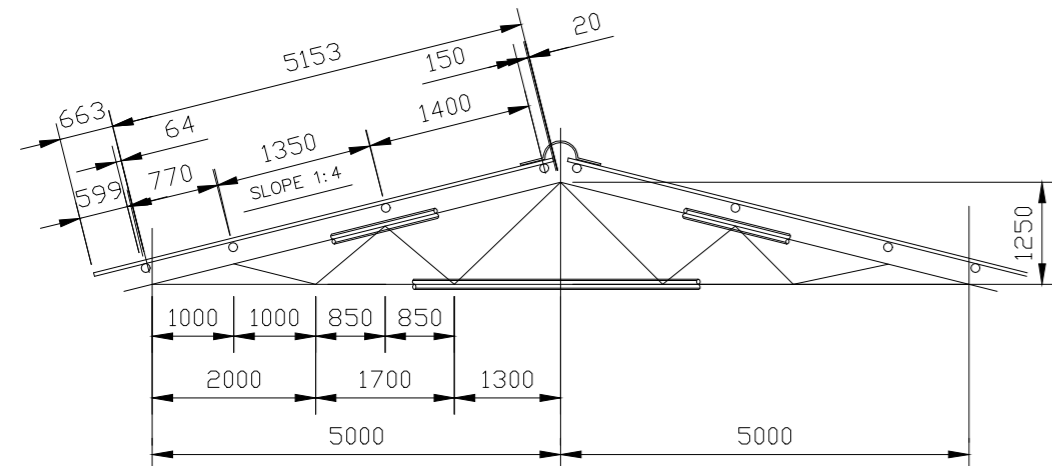

DETAIL OF TRUSS

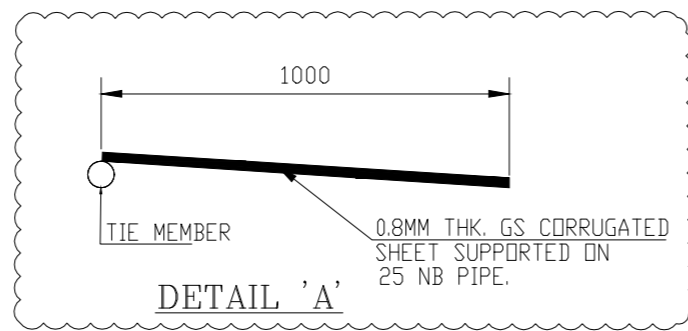

DETAIL 'A'

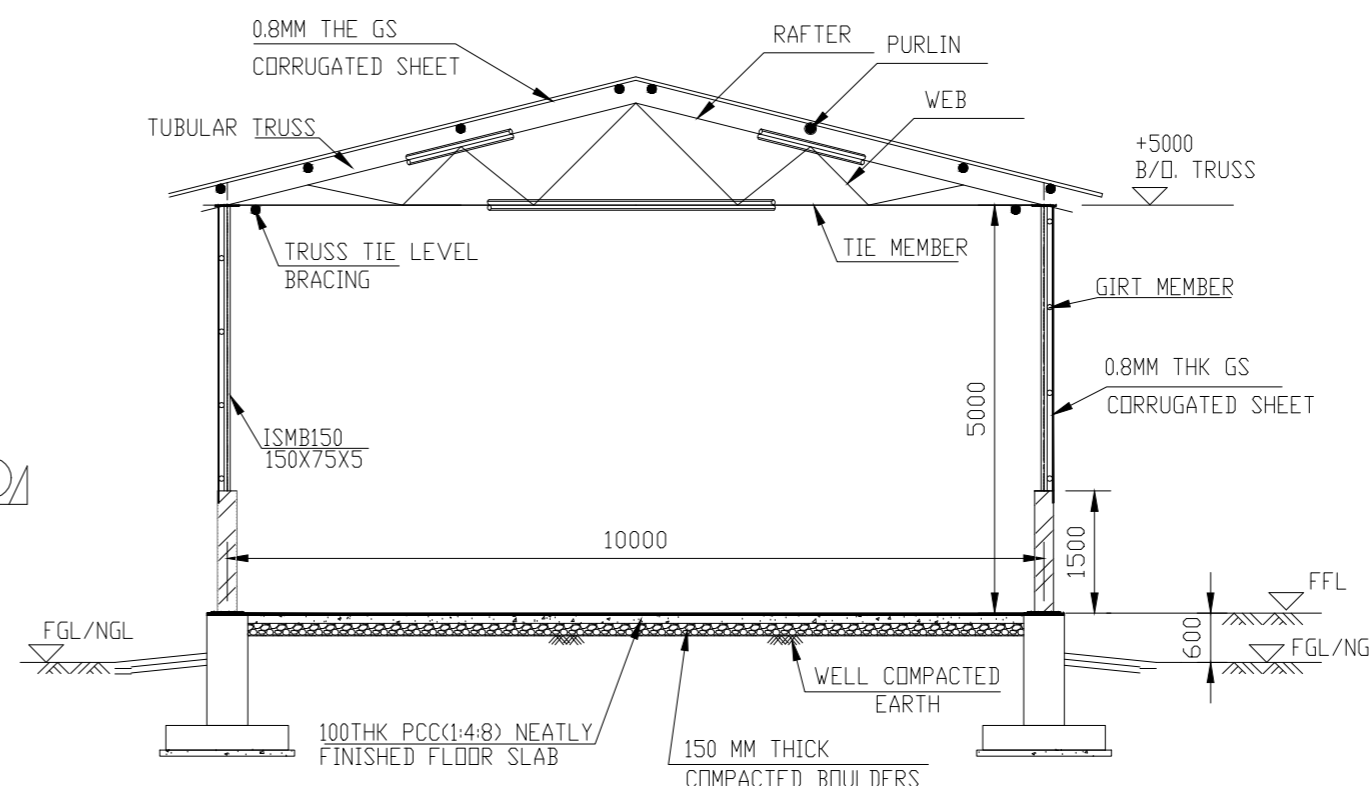

SECTION 2-2

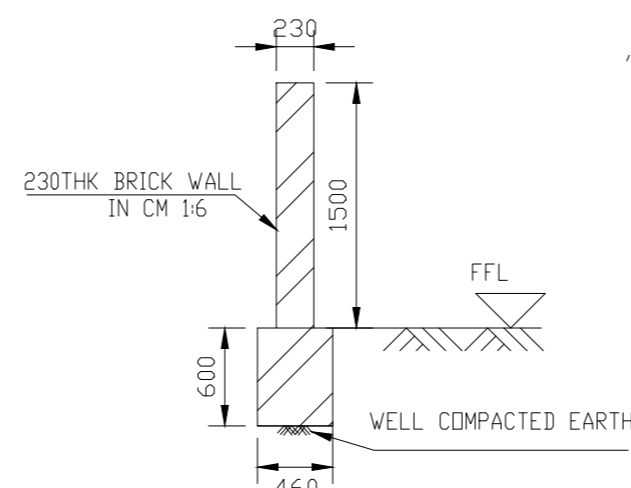

SECTION 3-3 (TYP.)

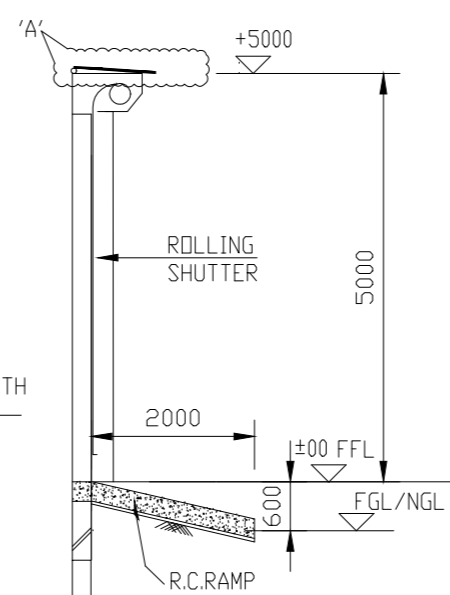

SECTION 1-1

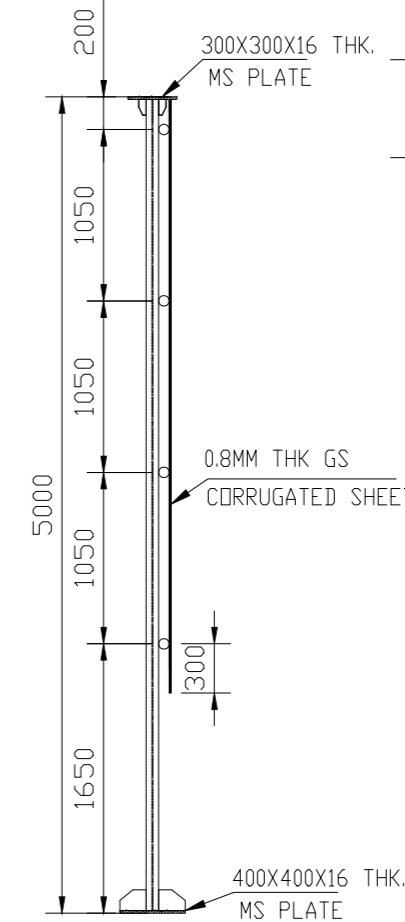

COLUMN & GIRT FIXING DETAILS (TYP.)

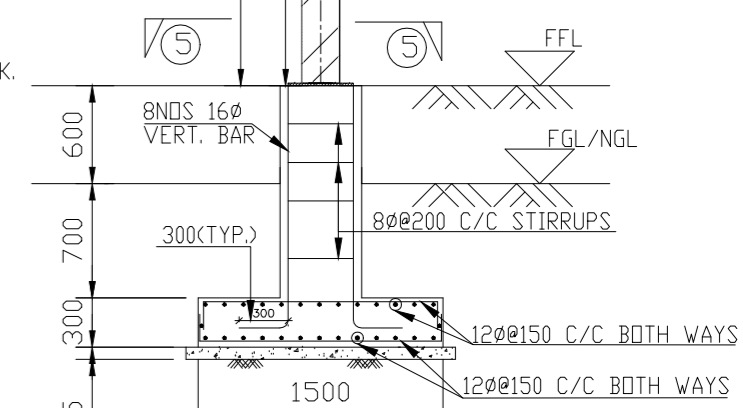

SECTION 4-4

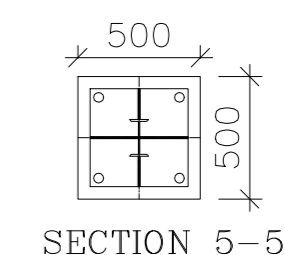

SECTION 5-5

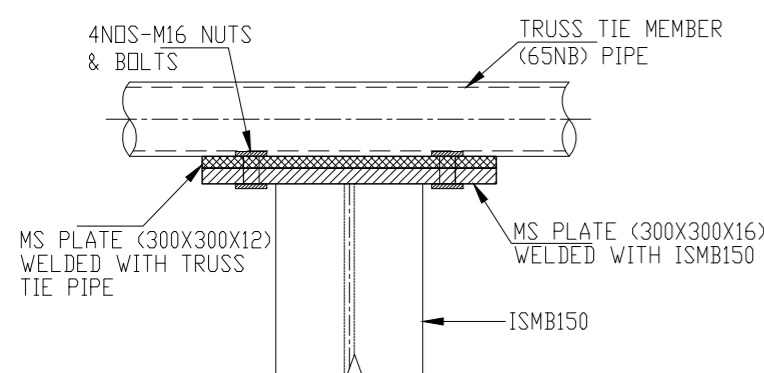

JOINT-1 (TYP.)

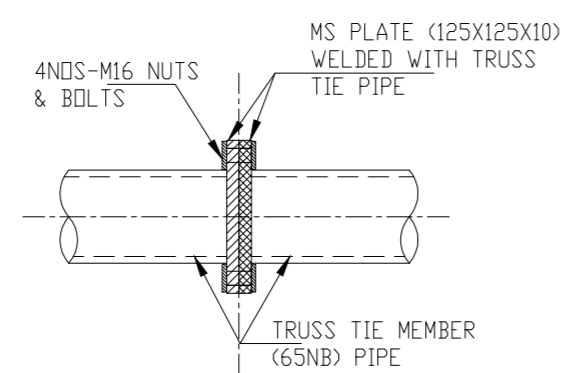

JOINT-2 (TYP.)

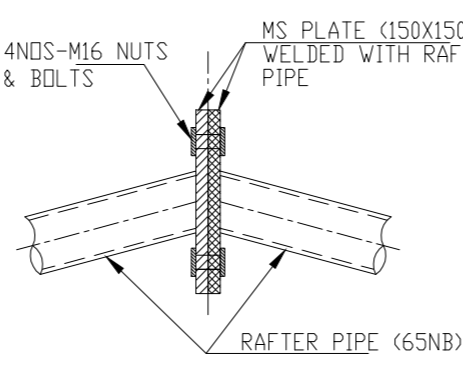

JOINT-3 (TYP.)

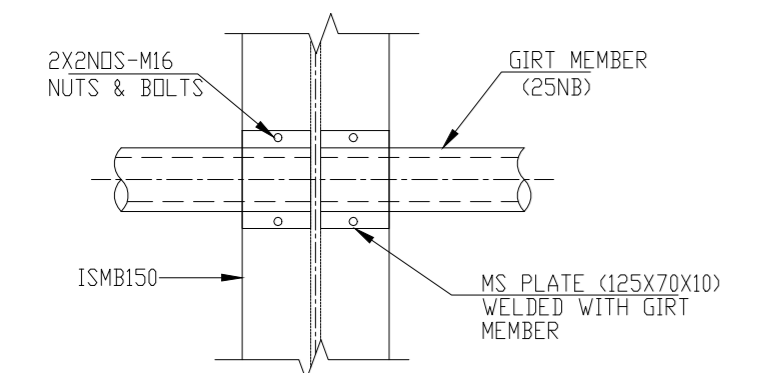

JOINT-4 (TYP.)

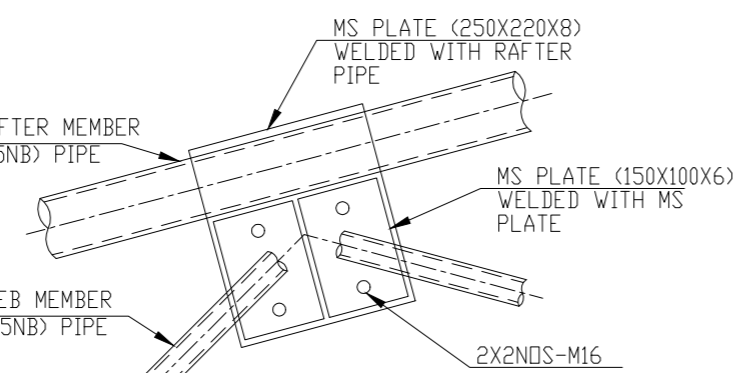

JOINT-5 (TYP.)

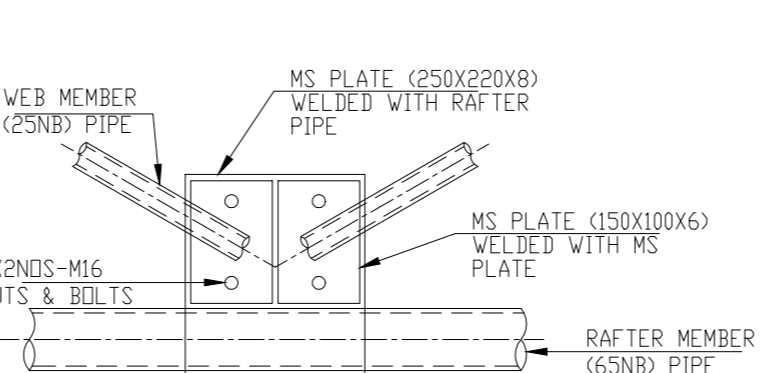

JOINT-6 (TYP.)

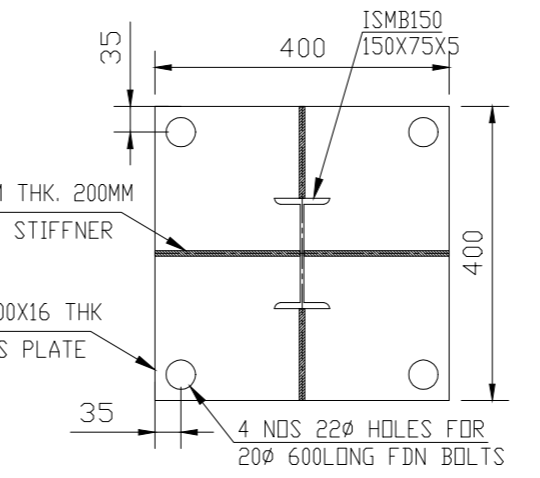

DETAIL OF BASE PLATE (TYP.)

SCHEDULE OF MEMBERS FOR PURLIN/TRUSS/TIE BRCCS.	
ITEM/MEMBER	SECTION
PURLIN	65 NB PIPE (MED.)
TRUSS	
RAFTER (TOP CHORD)	65 NB PIPE(MED)
TIE MEMBER (BOT. CHORD)	65 NB PIPE(MED)
DIAGONALS (WEB)	25 NB PIPE(MED)
TRUSS TIE LEVEL BRCC.	32 NB PIPE(MED)
GIRT MEMBER	25 NB PIPE(MED.)

- NOTES :-
- THIS DWG. SHALL BE READ IN CONJUNCTION WITH THE SPECIFICATION.
 - SITE TO INFORM, IF ANY MAJOR STRUCTURAL CHANGES DONE AT THE SITE.
 - * ISMB150 ENCLOSED IN BRICK WORK UPTO 5.0M HT. FOR FIXING OF ROLLING SHUTTER.
 - ANY OTHER ITEM/WORK, IF REQUIRED TO BE DONE FOR COMPLETION OF THE WORK, IS DEEMED TO BE INCLUDED IN THE RATE.
 - MOST OF THE CONNECTIONS SHALL BE BOLTED TYPE, DETAILS OF SOME OF THE CONNECTIONS HAVE BEEN GIVEN IN THE JOINT DETAILS 1 TO 6. JOINT NOT MENTIONED IN THIS DRAWING MAY BE KEPT WELDED OR BOLTED TYPE DEPENDING UPON THE SITE SUITABILITY REQUIREMENT.
 - JOINTS 1 TO 6 SHOWN IN THIS DRAWING ARE INDICATIVE AND WILL BE MODIFIED/CHANGED AS PER SITE AND FITMENT SUITABILITY.

	भारत हेवी इलेक्ट्रिकल्स लिमिटेड भारतीया भारी विद्युत प्रयोजन विभाग BHARAT HEAVY ELECTRICALS LTD. TRANSMISSION PROJECTS DIVISION	नाम /NAME GS	हस्ता /SIGN. -SD-	दि./DATE 21/10/24
	प्रजा /SCALE 1:1	कार्ड कोड CARD CODE	प्रजा /SCALE 1:1	कार्ड कोड CARD CODE
प्रजा /TITLE GA PLAN, SECTION & DETAILS FOR COVERED STORE (STANDARD DRAWING)	प्रजा /DRAWING NO. TB-STD-XXX-607-CS	प्रजा /REV. 00	प्रजा /SHEET No. 01	प्रजा /NEXT SHEET

SO-L09-D1S-B1
DRAWING No.

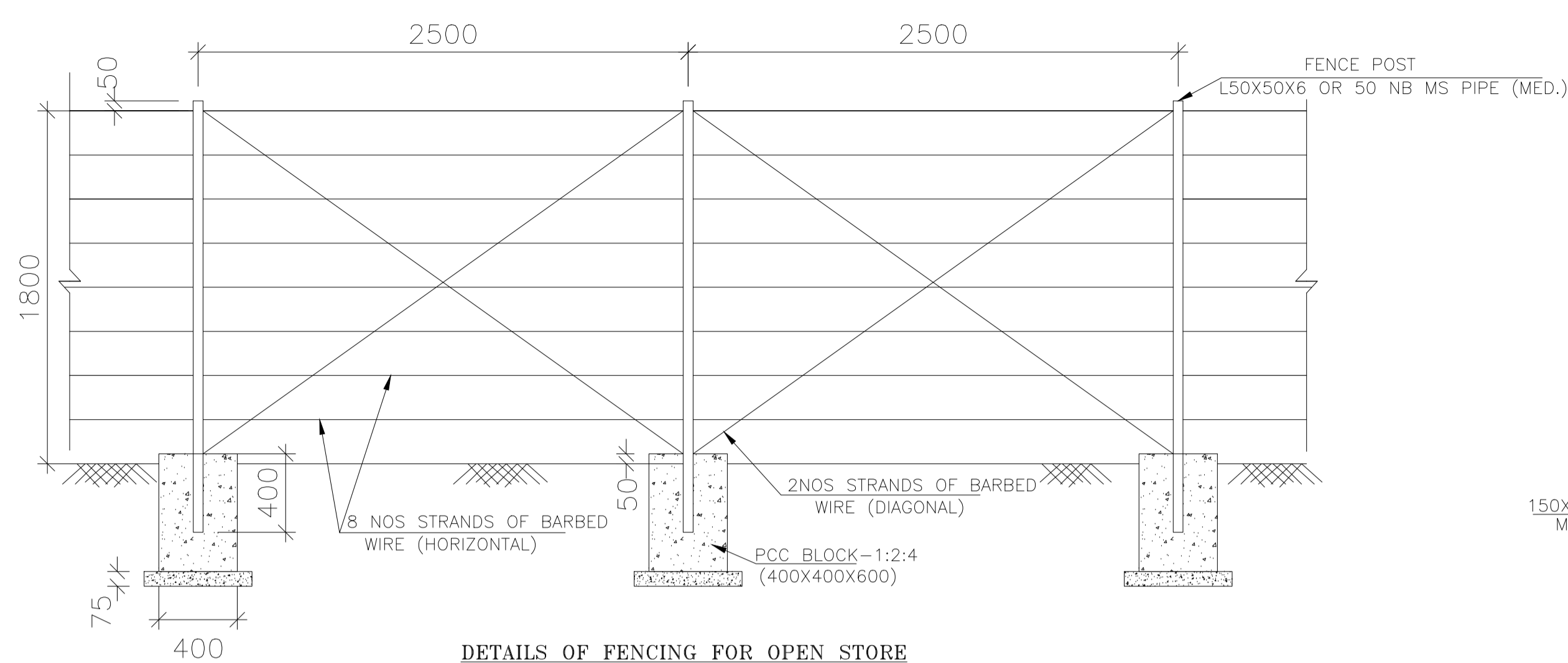

DETAILS OF FENCING FOR OPEN STORE
(SCALE 1:1)

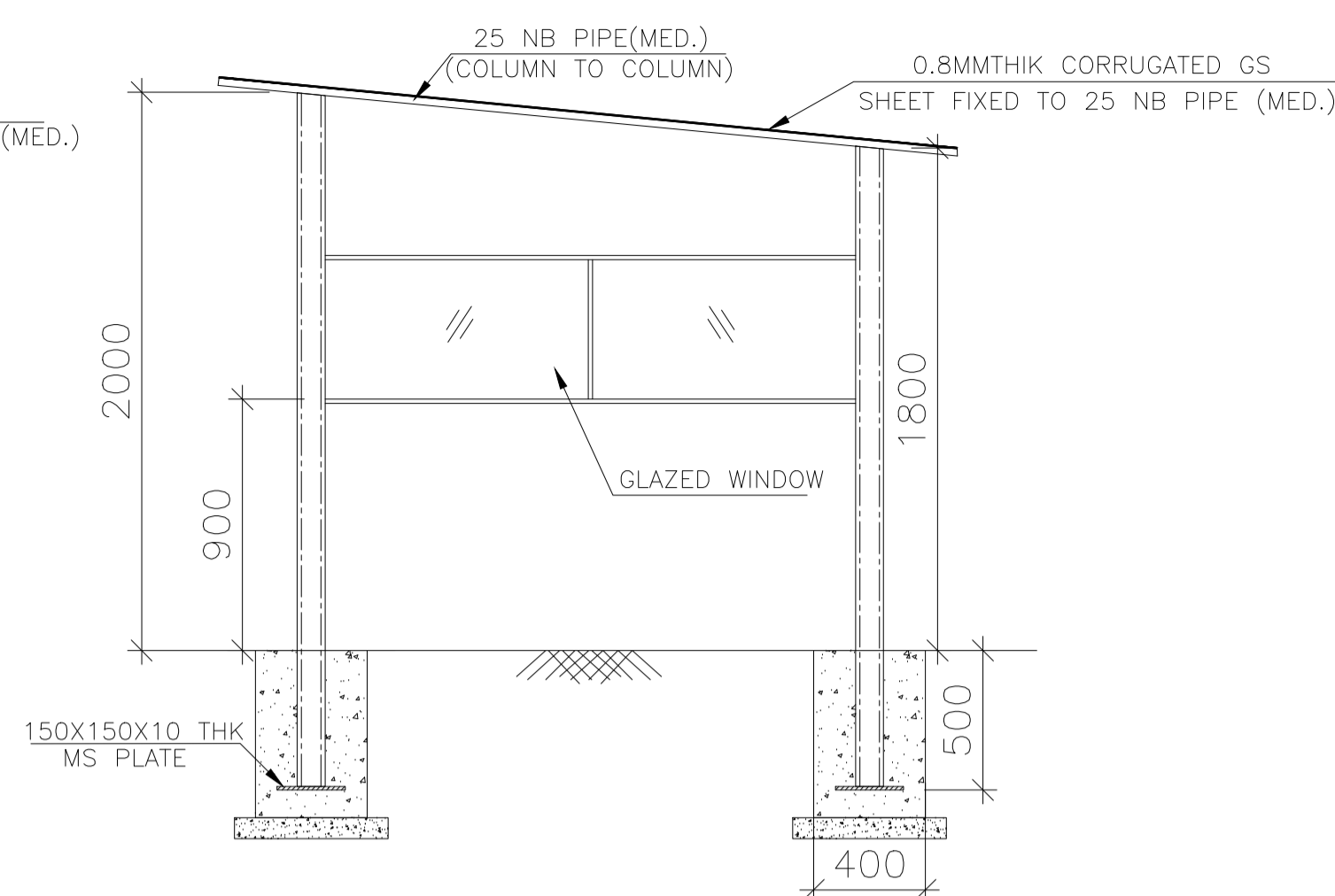

SIDE ELEVATION OF SECURITY CABIN
(SCALE 1:1)

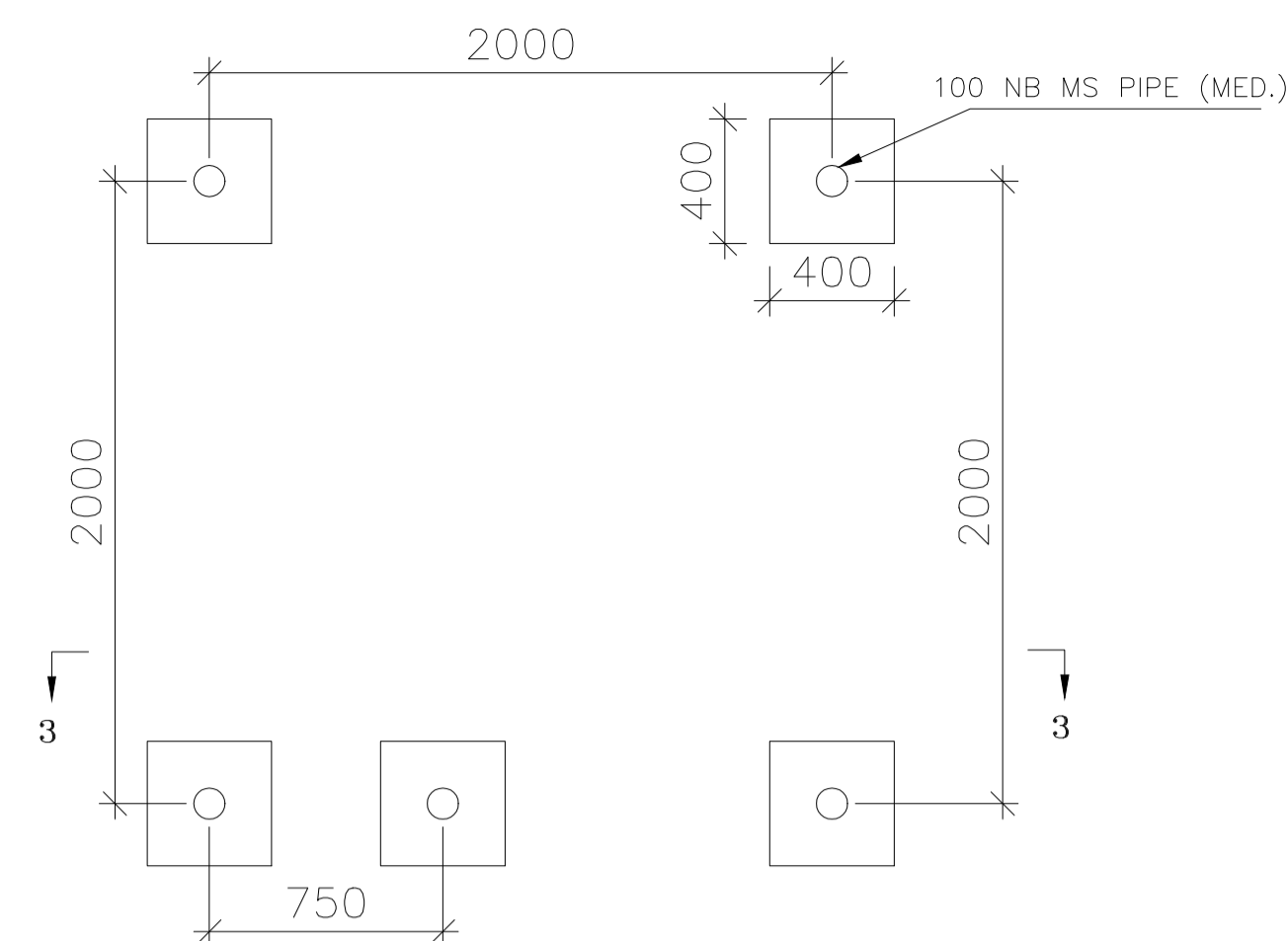

PLAN OF SECURITY CABIN
(SCALE 1:1)

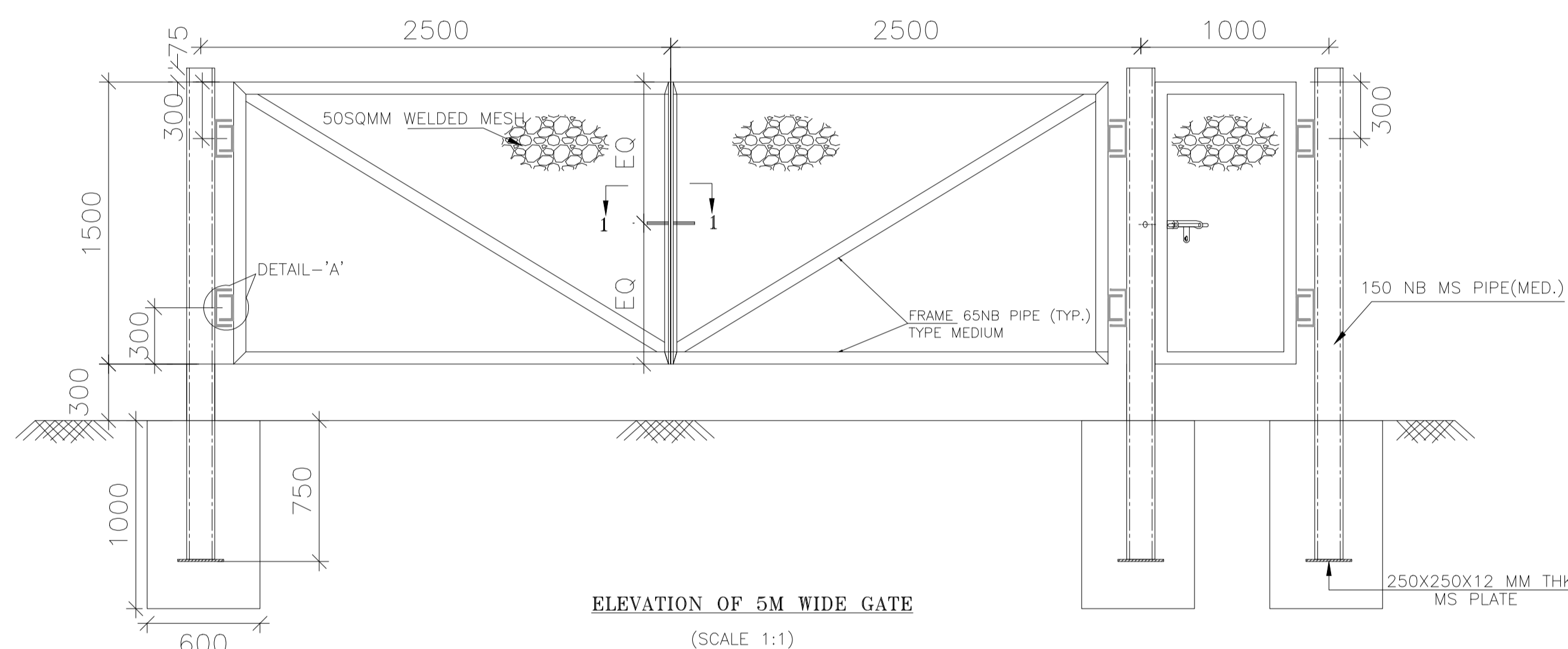

ELEVATION OF 5M WIDE GATE
(SCALE 1:1)

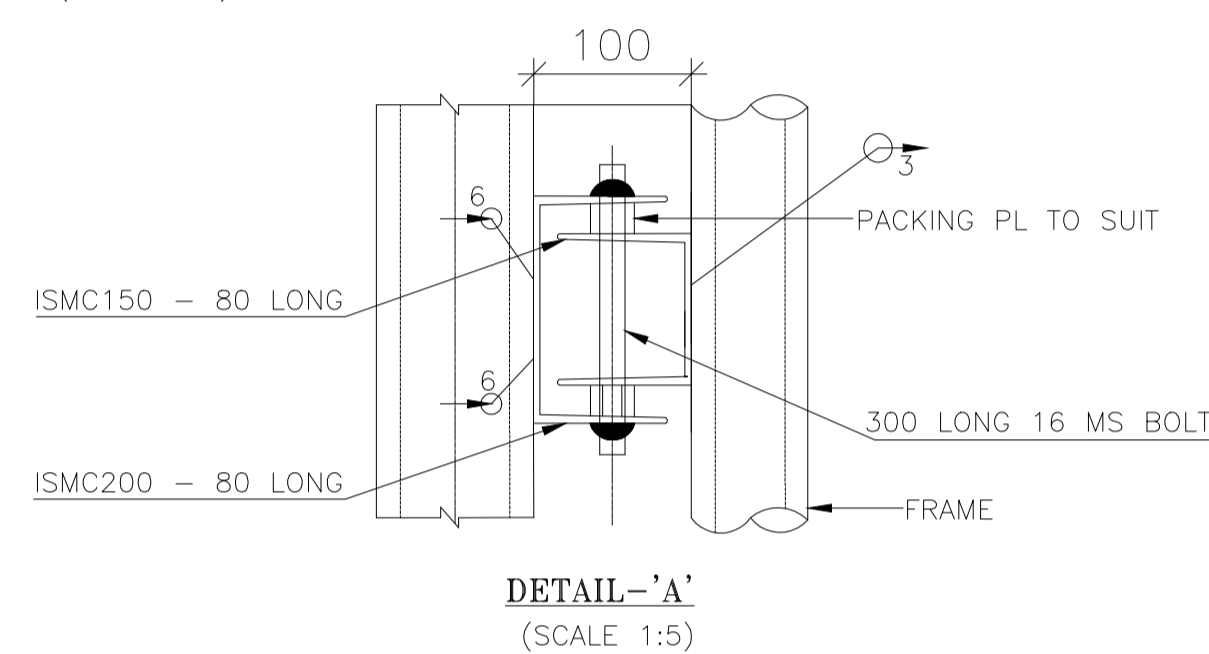

DETAIL-A'
(SCALE 1:5)

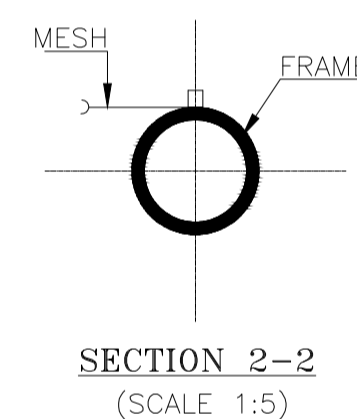

SECTION 2-2
(SCALE 1:5)

NOTES :-

1. THIS DRAWING SHALL BE READ IN CONJUNCTION WITH THE SPECIFICATION.
2. SITE TO INFORM, IF ANY MAJOR STRUCTURAL CHANGES DONE AT THE SITE.
3. GLAZED WINDOW CAN BE PUT TOWARDS OUTSIDE OF THE STORE.
4. ANY OTHER ITEM/WORK, IF REQUIRED TO BE DONE FOR COMPLETION OF THE WORK, IS DEEMED TO BE INCLUDED IN THE RATE.

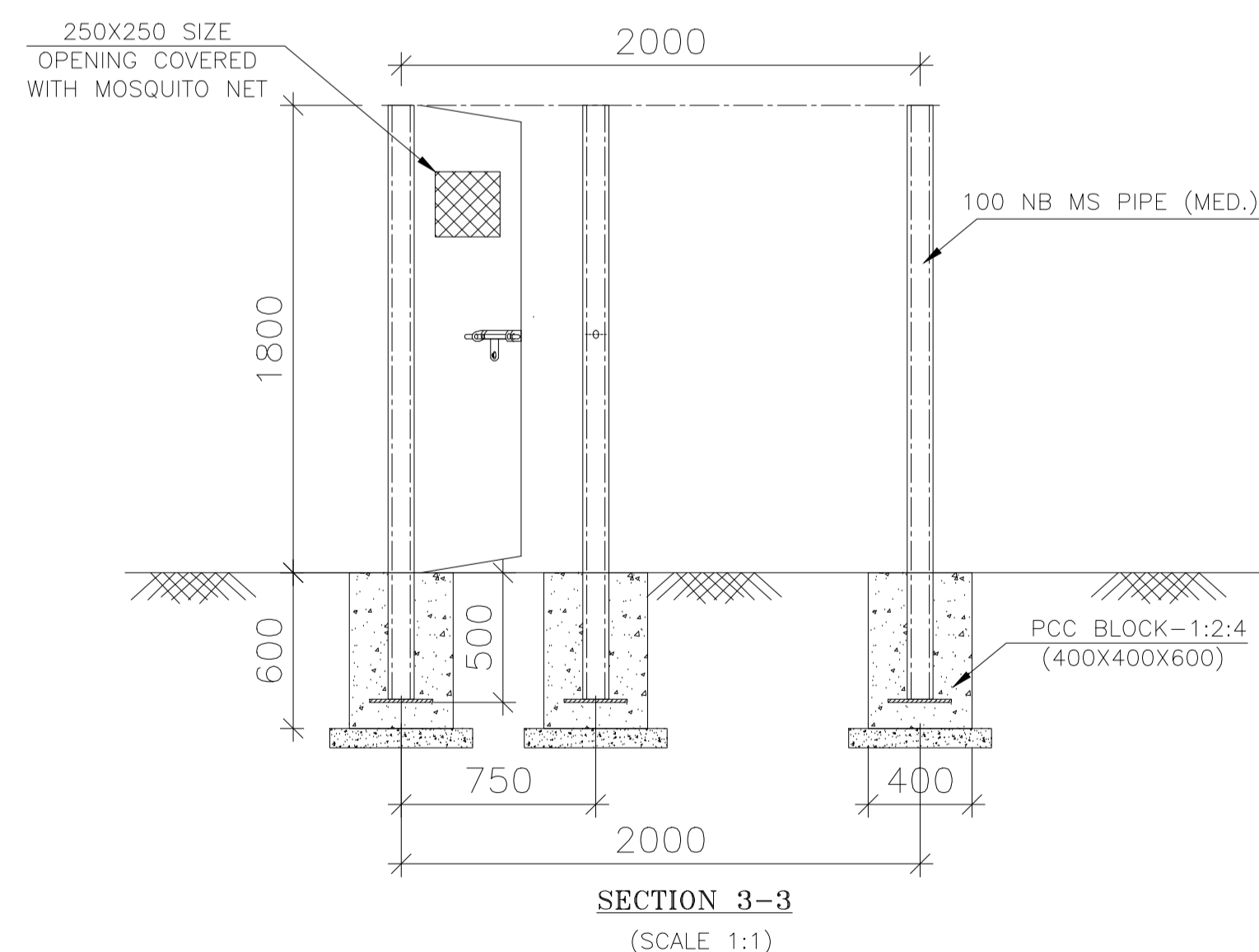

SECTION 3-3
(SCALE 1:1)

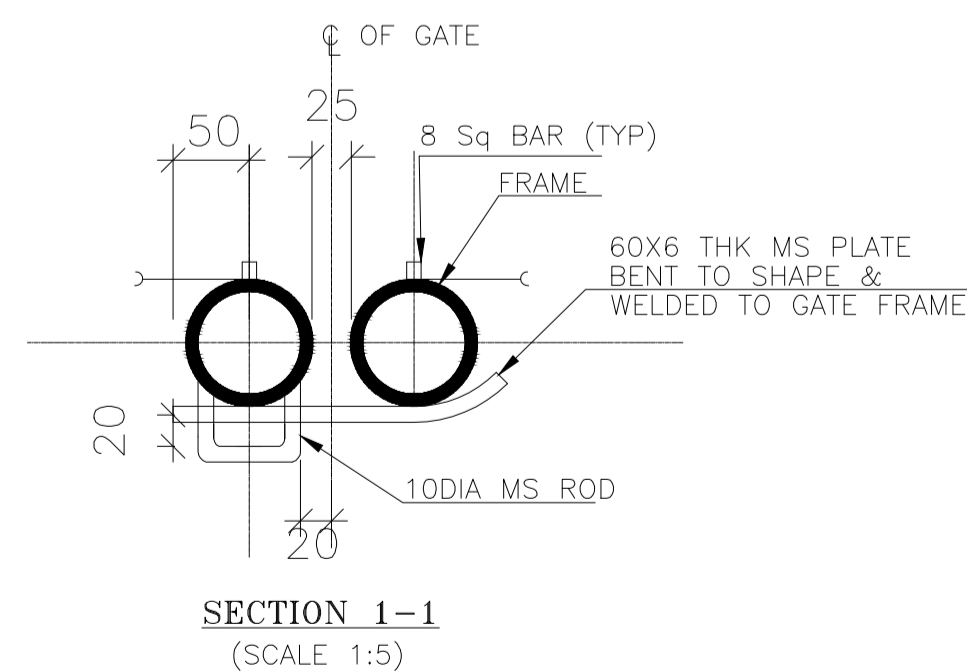

SECTION 1-1
(SCALE 1:5)

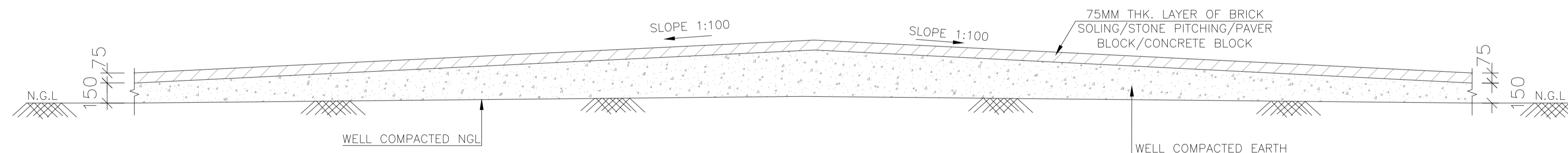

INDICATIVE DETAIL ONLY
SIZE SHALL BE AS PER WORK ORDER/SITE SUITABILITY

CA NO.	ग्राहक/परियोजना का नाम		
ADDITIONAL INFORMATION W.O.No.	NAME OF CUSTOMER/PROJECT		
STATUS OF DRAWING	Bharat Heavy Electricals Limited		
DISTRIBUTION OF PRINTS	TRANSMISSION PROJECTS DIVISION		
REV.	DATE	ALTERED	DATE
		CHECKED	
		APPROVED	
ZONE		ZONE	
विभाग DEPT.	अनुपात / SCALE	कार्ड कोड CARD CODE	ड्राईंग.क्र./BHEL DRAWING NO.
कोड CODE			पुनः/REV.
शीर्षक/TITLE	DETAILS FOR OPEN STORE (STANDARD DRAWING)		ड्राईंग.क्र./NTPC DRAWING NO. TB-STD-607-OS
			पुनः/REV. 00
			पृष्ठ क्र./SHEET No. 01 अगला पृष्ठ/NEXT SHEET --

COPY RIGHT AND CONFIDENTIAL
The information on this document is the property of BHARAT HEAVY ELECTRICALS LIMITED
It must not be used directly or indirectly in any way detrimental to the interest of the company.

COMPUTER DIR. PATH NAME :
SIGN. & DATE :
REF. DRG. No. :
INVENTORY No. :

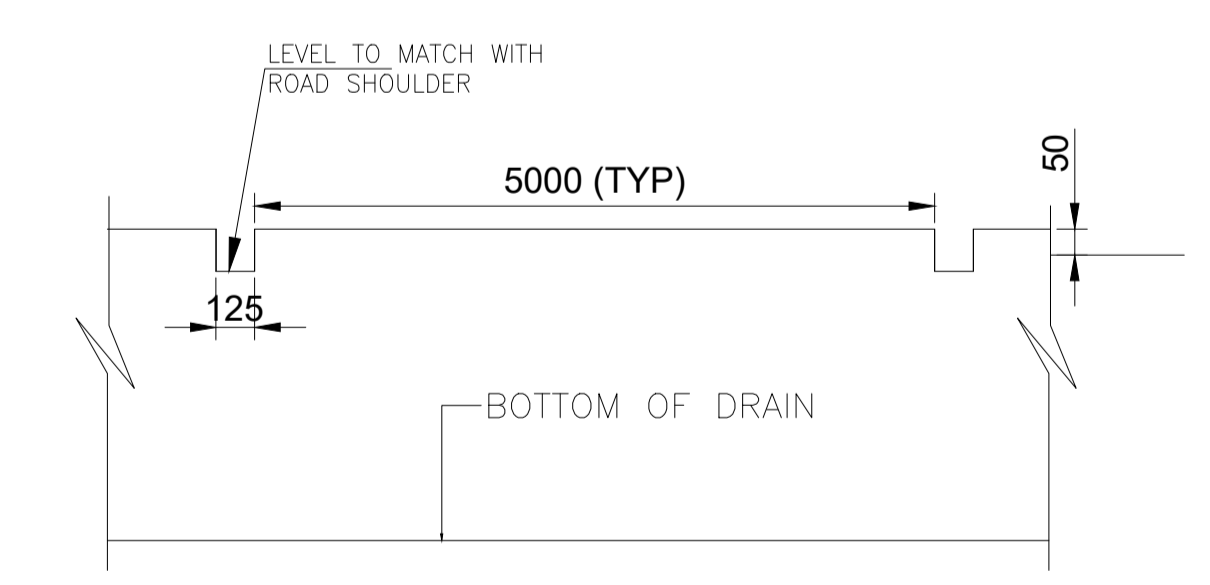
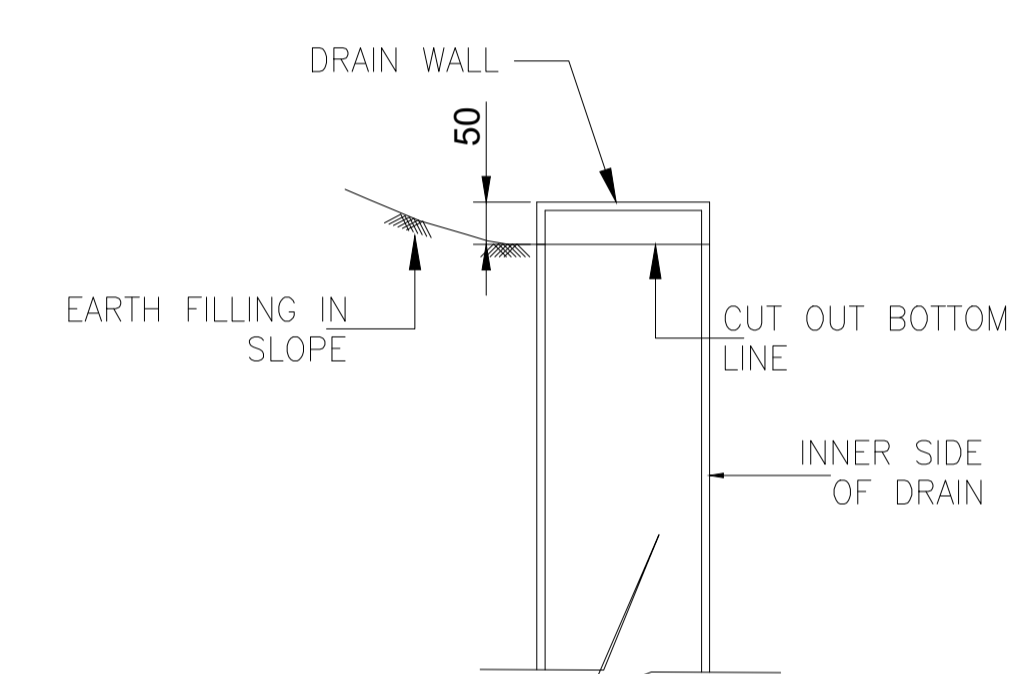
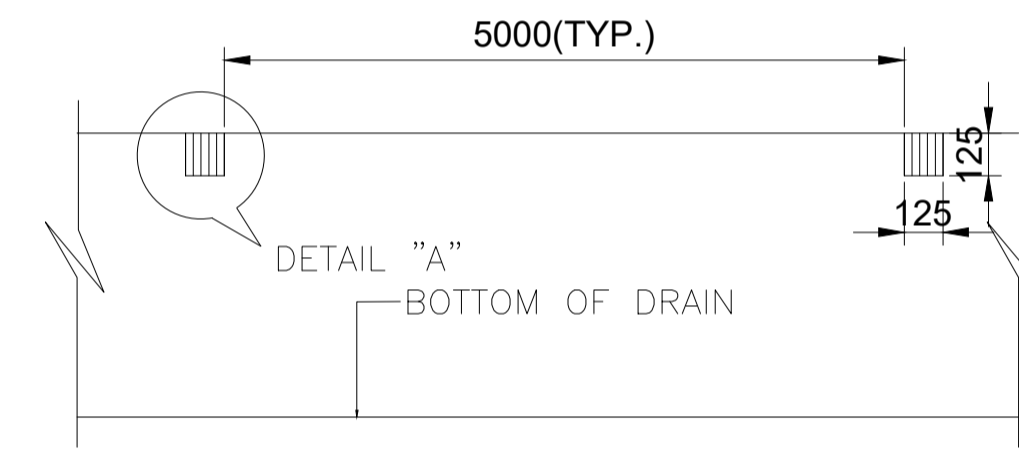
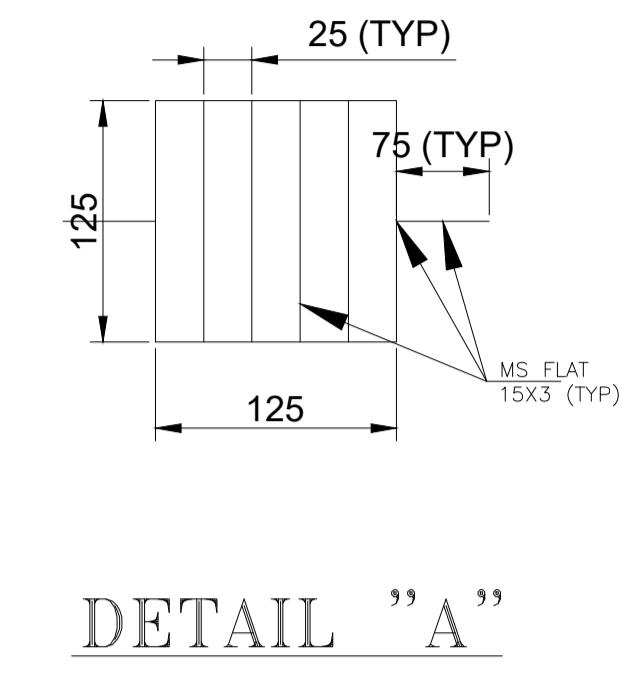
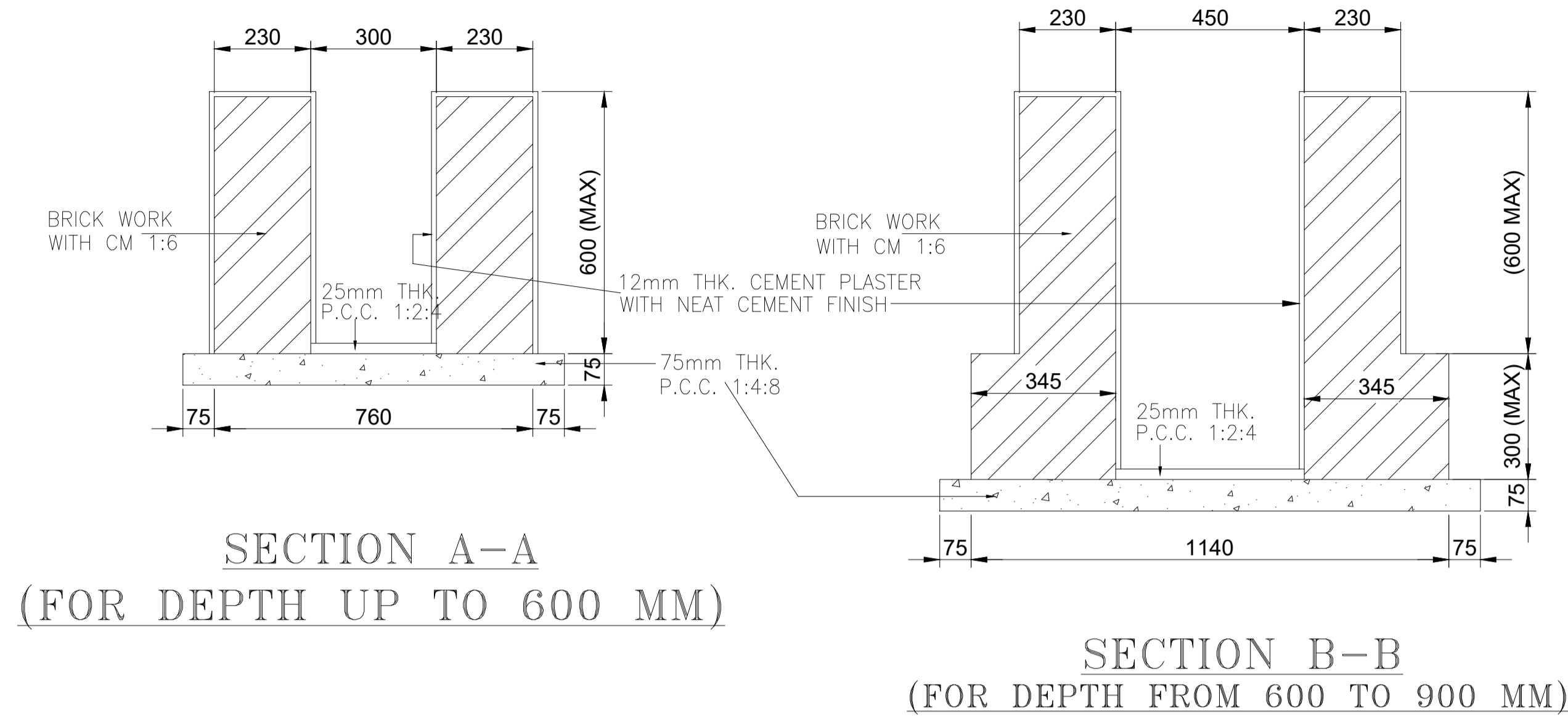

NOTES: -

1. ALL DIMENSIONS ARE IN MM & ELEVATIONS ARE IN METRE UNLESS NOTED OTHERWISE.
2. ALL DRAINS SHALL BE GIVEN A MINIMUM SLOPE OF 1:1000 IN THE LONGITUDINAL DIRECTION.
3. MINIMUM DEPTH OF DRAIN SHALL BE 300MM BELOW FGL.
4. WHERE EVER TWO SECTIONS ARE MEETING A TRANSITION ZONE SHALL BE CONSTRUCTED HAVING LENGTH 1000MM.
5. 75X75MM WEEP HOLE SHALL BE PROVIDED AT SPACING OF 1500MM HORIZONTALLY & 300MM VERTICALLY IN STAGGRED MANNER HOWEVER 75MM DIA PVC PIPE WEEP HOLE SHALL BE PROVIDED IN CASE OF RCC DRAIN.
6. DEPTH OF DRAIN IS TAKEN AS HEIGHT FROM TOP OF DRAIN TO INVERT OF DRAIN.
7. LAYOUT OF DRAIN WILL BE ISSUED DURING DETAILED ENGINEERING.
8. IF EXPANSIVE SOIL IS ENCOUNTERED AT FOUNDING LEVEL IT SHALL BE REMOVED TO A MINIMUM DEPTH OF 300MM AND SHALL BE REPLACED WELL COMPACTED (IN 3 EQ. LAYERS) LOCALLY AVAILABLE C.N.S. MATERIAL/SAND.
9. WHEREVER DRAINS ARE COMING IN THE SIDE OF SWITCHYARD/TOWNSHIP ROAD PROPER COMPACTION BETWEEN EDGE OF ROAD AND DRAIN SHOULD BE ENSURED.
10. 20MM WIDE EXPANSION JOINT SHALL BE PROVIDED IN RCC DRAIN @45M C/C. THE JOINT SHALL BE FILLED WITH 1:4 CEMENT SAND MORTAR.

The information on this document is the property of Bharat Heavy Electricals Ltd. It must not be used directly or indirectly in any way detrimental to the interest of the company.

कार्ड नं./JOB NO. 435 प्रोजेक्ट का स्थिति/PROJECT STATUS CONTRACT प्रकृत स्केल में/SCALE IN METRE 0 20 40 60 80		परियोजना PROJECT ±800 KV, 6000 MW HVDC BHADHLA	
भारत हेवी इलेक्ट्रिकल्स लिमिटेड BHARAT HEAVY ELECTRICALS LTD TRANSMISSION BUSINESS GROUP नई दिल्ली (N-1)/NOIDA (U.P.)		ड्रॉटिंग/DRW. SHEET ड्रॉटिंग/DRW. SHEET ड्रॉटिंग/DRW. SHEET	
शीट/NO. 01 OF 01			
ड्रॉटिंग/DRW. SHEET			