



**Bharat Heavy Electricals Limited**

**(A Govt. of India Undertaking)**

Piping Centre, 80, G. N. Chetty Road, CHENNAI – 600 017

Phone : 91 (044) 28161965, e-mail: [poongkodi@bhel.in](mailto:poongkodi@bhel.in)

REF: GEM/2022/B/2141965

DT: 01.05.2022

**Sub: Request For Quotation (RFQ) for supply of CS Seamless Pipes for IOCL Barauni & Panipat Refinery Projects - Reg.**

**Ref: Bid Number GEM/2022/B/2141965 dt 01.05.2022**

BHEL/Piping Centre invites RFQ's for supply of CS Seamless Pipes for IOCL Barauni & Panipat Refinery Projects. The offers should be submitted in the Government e-procurement portal (<https://gem.gov.in/>). The offer will be opened at **14.30 hrs** on the **due date 12.05.2022**.

Please find the bid document and the general terms and conditions for the GeM enquiry. Relevant drawings, PQR criteria and Technical delivery conditions are enclosed herewith.

This is only a request for quotation and not an order.

Interested bidders may take a note of the same and provide your quotation in GeM.

Ms. Poongkodi.V  
Deputy Manager / Purchase  
BHEL, Piping Centre  
80, G.N.Road, T.Nagar, Chennai –600 017  
Phone – 9488451450. Email: [poongkodi@bhel.in](mailto:poongkodi@bhel.in)

For any clarifications on the Enquiry you may also contact

Mr. Venkataraman E, DGM / Purchase, Phone – 044-28161325, Email: [vram@bhel.in](mailto:vram@bhel.in)

Ms. Priya Balaji, SDGM / Purchase, Phone – 044-28161244, Email: [pb@bhel.in](mailto:pb@bhel.in)

### Bid Document

| Bid Details  |  |
|--|--|
| <b>Bid End Date/Time</b>   | 12-05-2022 14:00:00  |
| <b>Bid Opening Date/Time</b>                                       | 12-05-2022 14:30:00  |
| <b>Bid Offer Validity (From End Date)</b>                          | 80 (Days)  |
| <b>Ministry/State Name</b>   | Ministry Of Heavy Industries And Public Enterprises  |
| <b>Department Name</b>   | Department Of Heavy Industry   |
| <b>Organisation Name</b>   | Bharat Heavy Electricals Limited (bhel)  |
| <b>Office Name</b>   | 10410005-pc Chennai  |
| <b>Total Quantity</b>  | 417  |
| <b>Item Category</b>   | P7471180998006 - PIPE OD 219.10 x 8.18 A106GR.B SMLS BE ASME B36.10M , P7471180998007 - PIPE OD 88.9X5.49 A106GR.B GALV AND THREADED SMLS BE ASME B36.10M , P7471180998008 - PIPE OD 26.7 X 5.56 A106GR.B SMLS PE ASME B36.10M HIC NACE HYDROGEN , P7471180998009 - PIPE OD 26.7 X 5.56 A106GR.B SMLS PE ASME B36.10M HIC NACE , P7471180998010 - PIPE OD 26.7 X 5.56 A106GR.B SMLS PE ASME B36.10M NACE , P7471180998011 - PIPE OD 26.7 X 5.56 A106GR.B SMLS PE ASME B36.10M HYDROGEN , P7471180998012 - PIPE OD 60.3 x 8.74 A106GR.B SMLS BE ASME B36.10M NACE , P7471180998013 - PIPE DIA 114.3 X 6.02 A106GR.B SMLS BE ASME B36.10M HYDROGEN , P7471180998014 - PIPE OD 219.10 x 8.18 A106GR.B SMLS BE ASME B36.10M HYDROGEN , P7471180998015 - PIPE OD 26.7 X 5.56 A333GR.6 SMLS PE ASME B36.10M , P7471180998016 - PIPE OD88.9X5.49 A333GR.6 SMLS BE ASME B36.10M HIC NACE , P7471180998017 - PIPE OD114.3X6.02 A333GR.6 SMLS BE ASME B36.10M , P7471180998018 - PIPE OD26.7X5.56 A106GR.B GALV AND THREADED SMLS TE ASME B36.10M , P7470180997002 - PIPE OD457.2 X 23.88, ASTM A106 GRB |
| <b>BOQ Title</b>   | CS SEAMLESS PIPES FOR IOCL BARAUNI AND PANIPAT PROJECTS  |
| <b>Minimum Average Annual Turnover of the bidder (For 3 Years)</b> | 6 Lakh (s)   |
| <b>Years of Past Experience Required for same/similar service</b>  | 3 Year (s)   |
| <b>MSE Exemption for Years of Experience and Turnover</b>          | No   |
| <b>Startup Exemption for Years of Experience and Turnover</b>      | No   |

| <b>Bid Details</b>   |   |
|--|---|
| <b>Document required from seller</b>   | Experience Criteria, Bidder Turnover, Certificate (Requested in ATC), Additional Doc 1 (Requested in ATC), Additional Doc 2 (Requested in ATC), Compliance of BoQ specification and supporting document<br>*In case any bidder is seeking exemption from Experience / Turnover Criteria, the supporting documents to prove his eligibility for exemption must be uploaded for evaluation by the buyer |
| <b>Bid to RA enabled</b>   | Yes   |
| <b>RA Qualification Rule</b>   | H1-Highest Priced Bid Elimination   |
| <b>Primary product category</b>  | P7470180997002 - PIPE OD457.2 X 23.88, ASTM A106 GRB  |
| <b>Time allowed for Technical Clarifications during technical evaluation</b> | 2 Days  |
| <b>Payment Timelines</b>   | Payments shall be made to the Seller within <b>90</b> days of issue of consignee receipt-cum-acceptance certificate (CRAC) and on-line submission of bills (This is in supersession of 10 days time as provided in clause 12 of GeM GTC)  |
| <b>Evaluation Method</b>   | Group wise evaluation   |

**EMD Detail**

|          |    |
|----------|----|
| Required | No |
|----------|----|

**ePBG Detail**

|          |    |
|----------|----|
| Required | No |
|----------|----|

(a). The EMD % will be applicable for each schedule/group selected during Bid creation.

**Splitting**

Bid splitting not applied.

**MII Purchase Preference**

|                         |     |
|-------------------------|-----|
| MII Purchase Preference | Yes |
|-------------------------|-----|

**MSE Purchase Preference**

|                         |     |
|-------------------------|-----|
| MSE Purchase Preference | Yes |
|-------------------------|-----|

1. The minimum average annual financial turnover of the bidder during the last three years, ending on 31st March of the previous financial year, should be as indicated above in the bid document. Documentary evidence in the form of certified Audited Balance Sheets of relevant periods or a certificate from the Chartered Accountant /

Cost Accountant indicating the turnover details for the relevant period shall be uploaded with the bid. In case the date of constitution / incorporation of the bidder is less than 3-year-old, the average turnover in respect of the completed financial years after the date of constitution shall be taken into account for this criteria.

2. Experience Criteria: In respect of the filter applied for experience criteria, the Bidder or its OEM {themselves or through reseller(s)} should have regularly, manufactured and supplied same or similar Category Products to any Central / State Govt Organization / PSU / Public Listed Company for number of Financial years as indicated above in the bid document before the bid opening date. Copies of relevant contracts to be submitted along with bid in support of having supplied some quantity during each of the Financial year. In case of bunch bids, the category of primary product having highest value should meet this criterion.

3. Preference to Make In India products (For bids < 200 Crore): Preference shall be given to Class 1 local supplier as defined in public procurement (Preference to Make in India), Order 2017 as amended from time to time and its subsequent Orders/Notifications issued by concerned Nodal Ministry for specific Goods/Products. The minimum local content to qualify as a Class 1 local supplier is denoted in the bid document. If the bidder wants to avail the Purchase preference, the bidder must upload a certificate from the OEM regarding the percentage of the local content and the details of locations at which the local value addition is made along with their bid, failing which no purchase preference shall be granted. In case the bid value is more than Rs 10 Crore, the declaration relating to percentage of local content shall be certified by the statutory auditor or cost auditor, if the OEM is a company and by a practicing cost accountant or a chartered accountant for OEMs other than companies as per the Public Procurement (preference to Make-in -India) order 2017 dated 04.06.2020. Only Class-I and Class-II Local suppliers as per MII order dated 4.6.2020 will be eligible to bid. Non - Local suppliers as per MII order dated 04.06.2020 are not eligible to participate. However, eligible micro and small enterprises will be allowed to participate .In case Buyer has selected Purchase preference to Micro and Small Enterprises clause in the bid, the same will get precedence over this clause.

4. Purchase preference to Micro and Small Enterprises (MSEs): Purchase preference will be given to MSEs as defined in Public Procurement Policy for Micro and Small Enterprises (MSEs) Order, 2012 dated 23.03.2012 issued by Ministry of Micro, Small and Medium Enterprises and its subsequent Orders/Notifications issued by concerned Ministry. If the bidder wants to avail the Purchase preference, the bidder must be the manufacturer of the offered product in case of bid for supply of goods. Traders are excluded from the purview of Public Procurement Policy for Micro and Small Enterprises. In respect of bid for Services, the bidder must be the Service provider of the offered Service. Relevant documentary evidence in this regard shall be uploaded along with the bid in respect of the offered product or service. If L-1 is not an MSE and MSE Seller (s) has/have quoted price within L-1+ 15% (Selected by Buyer) of margin of purchase preference /price band defined in relevant policy, such Seller shall be given opportunity to match L-1 price and contract will be awarded for 25%(selected by Buyer) percentage of total QUANTITY.

5. Estimated Bid Value indicated above is being declared solely for the purpose of guidance on EMD amount and for determining the Eligibility Criteria related to Turn Over, Past Performance and Project / Past Experience etc. This has no relevance or bearing on the price to be quoted by the bidders and is also not going to have any impact on bid participation. Also this is not going to be used as a criteria in determining reasonableness of quoted prices which would be determined by the buyer based on its own assessment of reasonableness and based on competitive prices received in Bid / RA process.

6. Reverse Auction would be conducted amongst all the technically qualified bidders except the Highest quoting bidder. The technically qualified Highest Quoting bidder will not be allowed to participate in RA. However, H-1 will also be allowed to participate in RA in following cases:

- i. If number of technically qualified bidders are only 2 or 3.
- ii. If Buyer has chosen to split the bid amongst N sellers, and H1 bid is coming within N.
- iii. In case Primary product of only one OEM is left in contention for participation in RA on elimination of H-1.
- iv. If L-1 is non-MSE and H-1 is eligible MSE and H-1 price is coming within price band of 15% of Non-MSE L-1
- v. If L-1 is non-MII and H-1 is eligible MII and H-1 price is coming within price band of 20% of Non-MII L-1

#### **Evaluation Method ( Group Wise Evaluation Method )**

Contract will be awarded schedulewise and the determination of L1 will be done separately for each schedule. The details of item-consignee combination covered under each schedule are as under:

| <b>Evaluation Schedules</b> | <b>Item/Category</b> | <b>Consignee/Reporting Officer</b> | <b>Consignee Address</b> | <b>Quantity</b> |
|-----------------------------|----------------------|------------------------------------|--------------------------|-----------------|
|                             |                      |                                    |                          |                 |

|            |  |  |  |  |
|------------|--|--|--|--|
| Schedule 1 | P7471180998006 - Pipe Od 219.10 X 8.18 A106gr.b Smls Be Asme B36.10m                 | Poongkodi Vijayakumar                                | 80, G.N. ROAD, T.NAGAR, CHENNAI-17. 600017 | 12   |
|            | P7471180998007 - Pipe Od 88.9x5.49 A106gr.b Galv And Threaded Smls Be Asme B36.10m   | Poongkodi Vijayakumar                                | 80, G.N. ROAD, T.NAGAR, CHENNAI-17. 600017 | 66   |
|            | P7471180998008 - Pipe Od 26.7 X 5.56 A106gr.b Smls Pe Asme B36.10m Hic Nace Hydrogen | Poongkodi Vijayakumar                                | 80, G.N. ROAD, T.NAGAR, CHENNAI-17. 600017 | 6  |
|            | P7471180998009 - Pipe Od 26.7 X 5.56 A106gr.b Smls Pe Asme B36.10m Hic Nace          | Poongkodi Vijayakumar                                | 80, G.N. ROAD, T.NAGAR, CHENNAI-17. 600017 | 36   |
|            | P7471180998010 - Pipe Od 26.7 X 5.56 A106gr.b Smls Pe Asme B36.10m Nace              | Poongkodi Vijayakumar                                | 80, G.N. ROAD, T.NAGAR, CHENNAI-17. 600017 | 93   |
|            | P7471180998011 - Pipe Od 26.7 X 5.56 A106gr.b Smls Pe Asme B36.10m Hydrogen          | Poongkodi Vijayakumar                                | 80, G.N. ROAD, T.NAGAR, CHENNAI-17. 600017 | 36   |
|            | P7471180998012 - Pipe Od 60.3 X 8.74 A106gr.b Smls Be Asme B36.10m Nace              | Poongkodi Vijayakumar                                | 80, G.N. ROAD, T.NAGAR, CHENNAI-17. 600017 | 12   |
|            | P7471180998013 - Pipe Dia 114.3 X 6.02 A106gr.b Smls Be Asme B36.10m Hydrogen        | Poongkodi Vijayakumar                                | 80, G.N. ROAD, T.NAGAR, CHENNAI-17. 600017 | 6  |
|            | P7471180998014 - Pipe Od 219.10 X 8.18 A106gr.b Smls Be Asme B36.10m Hydrogen        | Poongkodi Vijayakumar                                | 80, G.N. ROAD, T.NAGAR, CHENNAI-17. 600017 | 12   |
|            | P7471180998015 - Pipe Od 26.7 X 5.56 A333gr.6 Smls Pe Asme B36.10m                   | Poongkodi Vijayakumar                                | 80, G.N. ROAD, T.NAGAR, CHENNAI-17. 600017 | 48   |
|            | P7471180998016 - Pipe Od88.9x5.49 A333gr.6 Smls Be Asme B36.10m Hic Nace             | Poongkodi Vijayakumar                                | 80, G.N. ROAD, T.NAGAR, CHENNAI-17. 600017 | 6  |
|            | P7471180998017 - Pipe Od114.3x6.02 A333gr.6 Smls Be Asme B36.10m                     | Poongkodi Vijayakumar                                | 80, G.N. ROAD, T.NAGAR, CHENNAI-17. 600017 | 21   |
|            | P7471180998018 - Pipe Od26.7x5.56 A106gr.b Galv And Threaded Smls Te Asme B36.10m    | Poongkodi Vijayakumar                                | 80, G.N. ROAD, T.NAGAR, CHENNAI-17. 600017 | 33   |
|            | Schedule 2   | P7470180997002 - Pipe Od457.2 X 23.88, Astm A106 Grb | Poongkodi Vijayakumar                      | 80, G.N. ROAD, T.NAGAR, CHENNAI-17. 600017 |

**P7471180998006 - PIPE OD 219.10 X 8.18 A106GR.B SMLS BE ASME B36.10M**

**(Minimum 50% and 20% Local Content required for qualifying as Class 1 and Class 2 Local Supplier respectively)**

|            |           |
|------------|-----------|
| Brand Type | Unbranded |
|------------|-----------|

**Technical Specifications**

|                               |                           |
|-------------------------------|---------------------------|
| <b>Specification Document</b> | <a href="#">View File</a> |
| <b>BOQ Detail Document</b>    | <a href="#">View File</a> |

Advisory-Please refer attached BOQ document for detailed consignee list and delivery period.

#### Consignees/Reporting Officer and Quantity

| S.No. | Consignee/Reporting Officer | Address                                    | Quantity | Delivery Days |
|-------|-----------------------------|--|----------|---------------|
| 1     | Poongkodi Vijayakumar       | 600017,80, G.N. ROAD, T.NAGAR, CHENNAI-17. | 12       | 60            |

#### **P7471180998007 - PIPE OD 88.9X5.49 A106GR.B GALV AND THREADED SMLS BE ASME B36.10M**

(Minimum 50% and 20% Local Content required for qualifying as Class 1 and Class 2 Local Supplier respectively)

|            |           |
|------------|-----------|
| Brand Type | Unbranded |
|------------|-----------|

#### Technical Specifications

|                               |                           |
|-------------------------------|---------------------------|
| <b>Specification Document</b> | <a href="#">View File</a> |
| <b>BOQ Detail Document</b>    | <a href="#">View File</a> |

Advisory-Please refer attached BOQ document for detailed consignee list and delivery period.

#### Consignees/Reporting Officer and Quantity

| S.No. | Consignee/Reporting Officer | Address                                    | Quantity | Delivery Days |
|-------|-----------------------------|--|----------|---------------|
| 1     | Poongkodi Vijayakumar       | 600017,80, G.N. ROAD, T.NAGAR, CHENNAI-17. | 66       | 60            |

#### **P7471180998008 - PIPE OD 26.7 X 5.56 A106GR.B SMLS PE ASME B36.10M HIC NACE**

## HYDROGEN

**(Minimum 50% and 20% Local Content required for qualifying as Class 1 and Class 2 Local Supplier respectively)**

|            |           |
|------------|-----------|
| Brand Type | Unbranded |
|------------|-----------|

### Technical Specifications

|                               |                           |
|-------------------------------|---------------------------|
| <b>Specification Document</b> | <a href="#">View File</a> |
| <b>BOQ Detail Document</b>    | <a href="#">View File</a> |

Advisory-Please refer attached BOQ document for detailed consignee list and delivery period.

### Consignees/Reporting Officer and Quantity

| S.No. | Consignee/Reporting Officer | Address                                    | Quantity | Delivery Days |
|-------|-----------------------------|--|----------|---------------|
| 1     | Pongkodi Vijayakumar        | 600017,80, G.N. ROAD, T.NAGAR, CHENNAI-17. | 6        | 60            |

## P7471180998009 - PIPE OD 26.7 X 5.56 A106GR.B SMLS PE ASME B36.10M HIC NACE

**(Minimum 50% and 20% Local Content required for qualifying as Class 1 and Class 2 Local Supplier respectively)**

|            |           |
|------------|-----------|
| Brand Type | Unbranded |
|------------|-----------|

### Technical Specifications

|                               |                           |
|-------------------------------|---------------------------|
| <b>Specification Document</b> | <a href="#">View File</a> |
| <b>BOQ Detail Document</b>    | <a href="#">View File</a> |

Advisory-Please refer attached BOQ document for detailed consignee list and delivery period.

### Consignees/Reporting Officer and Quantity

| S.No. | Consignee/Reporting Officer | Address                                    | Quantity | Delivery Days |
|-------|-----------------------------|--|----------|---------------|
| 1     | Poongkodi Vijayakumar       | 600017,80, G.N. ROAD, T.NAGAR, CHENNAI-17. | 36       | 60            |

**P7471180998010 - PIPE OD 26.7 X 5.56 A106GR.B SMLS PE ASME B36.10M NACE**

**(Minimum 50% and 20% Local Content required for qualifying as Class 1 and Class 2 Local Supplier respectively)**

|            |           |
|------------|-----------|
| Brand Type | Unbranded |
|------------|-----------|

**Technical Specifications**

|                               |                           |
|-------------------------------|---------------------------|
| <b>Specification Document</b> | <a href="#">View File</a> |
| <b>BOQ Detail Document</b>    | <a href="#">View File</a> |

Advisory-Please refer attached BOQ document for detailed consignee list and delivery period.

**Consignees/Reporting Officer and Quantity**

| S.No. | Consignee/Reporting Officer | Address                                    | Quantity | Delivery Days |
|-------|-----------------------------|--|----------|---------------|
| 1     | Poongkodi Vijayakumar       | 600017,80, G.N. ROAD, T.NAGAR, CHENNAI-17. | 93       | 60            |

**P7471180998011 - PIPE OD 26.7 X 5.56 A106GR.B SMLS PE ASME B36.10M HYDROGEN**

**(Minimum 50% and 20% Local Content required for qualifying as Class 1 and Class 2 Local Supplier respectively)**

|            |           |
|------------|-----------|
| Brand Type | Unbranded |
|------------|-----------|

**Technical Specifications**

|                               |                           |
|-------------------------------|---------------------------|
| <b>Specification Document</b> | <a href="#">View File</a> |
| <b>BOQ Detail Document</b>    | <a href="#">View File</a> |

Advisory-Please refer attached BOQ document for detailed consignee list and delivery period.

**Consignees/Reporting Officer and Quantity**

| S.No. | Consignee/Reporting Officer | Address                                    | Quantity | Delivery Days |
|-------|-----------------------------|--|----------|---------------|
| 1     | Poongkodi Vijayakumar       | 600017,80, G.N. ROAD, T.NAGAR, CHENNAI-17. | 36       | 60            |

**P7471180998012 - PIPE OD 60.3 X 8.74 A106GR.B SMLS BE ASME B36.10M NACE**

(Minimum 50% and 20% Local Content required for qualifying as Class 1 and Class 2 Local Supplier respectively)

|            |           |
|------------|-----------|
| Brand Type | Unbranded |
|------------|-----------|

**Technical Specifications**

|                        |                           |
|------------------------|---------------------------|
| Specification Document | <a href="#">View File</a> |
| BOQ Detail Document    | <a href="#">View File</a> |

Advisory-Please refer attached BOQ document for detailed consignee list and delivery period.

**Consignees/Reporting Officer and Quantity**

| S.No. | Consignee/Reporting Officer | Address                                    | Quantity | Delivery Days |
|-------|-----------------------------|--|----------|---------------|
| 1     | Poongkodi Vijayakumar       | 600017,80, G.N. ROAD, T.NAGAR, CHENNAI-17. | 12       | 60            |

**P7471180998013 - PIPE DIA 114.3 X 6.02 A106GR.B SMLS BE ASME B36.10M HYDROGEN**

(Minimum 50% and 20% Local Content required for qualifying as Class 1 and Class 2 Local Supplier respectively)

|            |           |
|------------|-----------|
| Brand Type | Unbranded |
|------------|-----------|

**Technical Specifications**

|                        |                           |
|------------------------|---------------------------|
| Specification Document | <a href="#">View File</a> |
| BOQ Detail Document    | <a href="#">View File</a> |

Advisory-Please refer attached BOQ document for detailed consignee list and delivery period.

#### Consignees/Reporting Officer and Quantity

| S.No. | Consignee/Reporting Officer | Address                                       | Quantity | Delivery Days |
|-------|-----------------------------|---|----------|---------------|
| 1     | Poongkodi<br>Vijayakumar    | 600017,80, G.N. ROAD,<br>T.NAGAR, CHENNAI-17. | 6        | 60            |

#### **P7471180998014 - PIPE OD 219.10 X 8.18 A106GR.B SMLS BE ASME B36.10M HYDROGEN**

**(Minimum 50% and 20% Local Content required for qualifying as Class 1 and Class 2 Local Supplier respectively)**

|            |           |
|------------|-----------|
| Brand Type | Unbranded |
|------------|-----------|

#### Technical Specifications

|                        |                           |
|------------------------|---------------------------|
| Specification Document | <a href="#">View File</a> |
| BOQ Detail Document    | <a href="#">View File</a> |

Advisory-Please refer attached BOQ document for detailed consignee list and delivery period.

#### Consignees/Reporting Officer and Quantity

| S.No. | Consignee/Reporting Officer | Address                                       | Quantity | Delivery Days |
|-------|-----------------------------|---|----------|---------------|
| 1     | Poongkodi<br>Vijayakumar    | 600017,80, G.N. ROAD,<br>T.NAGAR, CHENNAI-17. | 12       | 60            |

#### **P7471180998015 - PIPE OD 26.7 X 5.56 A333GR.6 SMLS PE ASME B36.10M**

**(Minimum 50% and 20% Local Content required for qualifying as Class 1 and Class 2 Local Supplier respectively)**

|            |           |
|------------|-----------|
| Brand Type | Unbranded |
|------------|-----------|

**Technical Specifications**

|                               |                           |
|-------------------------------|---------------------------|
| <b>Specification Document</b> | <a href="#">View File</a> |
| <b>BOQ Detail Document</b>    | <a href="#">View File</a> |

Advisory-Please refer attached BOQ document for detailed consignee list and delivery period.

**Consignees/Reporting Officer and Quantity**

| S.No. | Consignee/Reporting Officer | Address                                    | Quantity | Delivery Days |
|-------|-----------------------------|--|----------|---------------|
| 1     | Poongkodi Vijayakumar       | 600017,80, G.N. ROAD, T.NAGAR, CHENNAI-17. | 48       | 60            |

**P7471180998016 - PIPE OD88.9X5.49 A333GR.6 SMLS BE ASME B36.10M HIC NACE**

**(Minimum 50% and 20% Local Content required for qualifying as Class 1 and Class 2 Local Supplier respectively)**

|            |           |
|------------|-----------|
| Brand Type | Unbranded |
|------------|-----------|

**Technical Specifications**

|                               |                           |
|-------------------------------|---------------------------|
| <b>Specification Document</b> | <a href="#">View File</a> |
| <b>BOQ Detail Document</b>    | <a href="#">View File</a> |

Advisory-Please refer attached BOQ document for detailed consignee list and delivery period.

**Consignees/Reporting Officer and Quantity**

| S.No. | Consignee/Reporting Officer | Address | Quantity | Delivery Days |
|-------|-----------------------------|---------|----------|---------------|
|-------|-----------------------------|---------|----------|---------------|

| S.No. | Consignee/Reporting Officer | Address                                    | Quantity | Delivery Days |
|-------|-----------------------------|--|----------|---------------|
| 1     | Poongkodi Vijayakumar       | 600017,80, G.N. ROAD, T.NAGAR, CHENNAI-17. | 6        | 60            |

**P7471180998017 - PIPE OD114.3X6.02 A333GR.6 SMLS BE ASME B36.10M**

(Minimum 50% and 20% Local Content required for qualifying as Class 1 and Class 2 Local Supplier respectively)

|            |           |
|------------|-----------|
| Brand Type | Unbranded |
|------------|-----------|

**Technical Specifications**

|                        |                           |
|------------------------|---------------------------|
| Specification Document | <a href="#">View File</a> |
| BOQ Detail Document    | <a href="#">View File</a> |

Advisory-Please refer attached BOQ document for detailed consignee list and delivery period.

**Consignees/Reporting Officer and Quantity**

| S.No. | Consignee/Reporting Officer | Address                                    | Quantity | Delivery Days |
|-------|-----------------------------|--|----------|---------------|
| 1     | Poongkodi Vijayakumar       | 600017,80, G.N. ROAD, T.NAGAR, CHENNAI-17. | 21       | 60            |

**P7471180998018 - PIPE OD26.7X5.56 A106GR.B GALV AND THREADED SMLS TE ASME B36.10M**

(Minimum 50% and 20% Local Content required for qualifying as Class 1 and Class 2 Local Supplier respectively)

|            |           |
|------------|-----------|
| Brand Type | Unbranded |
|------------|-----------|

**Technical Specifications**

|                        |                           |
|------------------------|---------------------------|
| Specification Document | <a href="#">View File</a> |
| BOQ Detail Document    | <a href="#">View File</a> |

Advisory-Please refer attached BOQ document for detailed consignee list and delivery period.

### Consignees/Reporting Officer and Quantity

| S.No. | Consignee/Reporting Officer | Address                                    | Quantity | Delivery Days |
|-------|-----------------------------|--|----------|---------------|
| 1     | Poongkodi Vijayakumar       | 600017,80, G.N. ROAD, T.NAGAR, CHENNAI-17. | 33       | 60            |

### P7470180997002 - PIPE OD457.2 X 23.88, ASTM A106 GRB

(Minimum 50% and 20% Local Content required for qualifying as Class 1 and Class 2 Local Supplier respectively)

|            |           |
|------------|-----------|
| Brand Type | Unbranded |
|------------|-----------|

### Technical Specifications

|                        |                           |
|------------------------|---------------------------|
| Specification Document | <a href="#">View File</a> |
| BOQ Detail Document    | <a href="#">View File</a> |

Advisory-Please refer attached BOQ document for detailed consignee list and delivery period.

### Consignees/Reporting Officer and Quantity

| S.No. | Consignee/Reporting Officer | Address                                    | Quantity | Delivery Days |
|-------|-----------------------------|--|----------|---------------|
| 1     | Poongkodi Vijayakumar       | 600017,80, G.N. ROAD, T.NAGAR, CHENNAI-17. | 30       | 60            |

## Buyer Added Bid Specific Terms and Conditions

#### 1. Scope of Supply

Scope of supply (Bid price to include all cost components) : Only supply of Goods

#### 2. Generic

Actual delivery (and Installation & Commissioning (if covered in scope of supply)) is to be done at following address Deputy General Manager (Materials -Projects), Indian Oil Corporation Limited BR-9

Project, P.O. Barauni Refinery, Distt.: Begusarai, Bihar - 861114 - FOR SCHEDULE 1 Deputy General Manager (Materials -Projects), Indian Oil Corporation Limited, Panipat Refinery, P.O- Panipat Refinery Panipat, Haryana-132140 - FOR SCHEDULE 2 ..

### 3. **Generic**

Bidder shall submit the following documents along with their bid for Vendor Code Creation:

- a. Copy of PAN Card.
- b. Copy of GSTIN.
- c. Copy of Cancelled Cheque.
- d. Copy of EFT Mandate duly certified by Bank.

### 4. **Generic**

OPTION CLAUSE: The Purchaser reserves the right to increase or decrease the quantity to be ordered up to 25 percent of bid quantity at the time of placement of contract. The purchaser also reserves the right to increase the ordered quantity by up to 25% of the contracted quantity during the currency of the contract at the contracted rates. Bidders are bound to accept the orders accordingly.

### 5. **Generic**

Bidders are advised to check applicable GST on their own before quoting. Buyer will not take any responsibility in this regards. GST reimbursement will be as per actuals or as per applicable rates (whichever is lower), subject to the maximum of quoted GST %.

### 6. **Generic**

While generating invoice in GeM portal, the seller must upload scanned copy of GST invoice and the screenshot of GST portal confirming payment of GST.

### 7. **Certificates**

Bidder's offer is liable to be rejected if they don't upload any of the certificates / documents sought in the Bid document, ATC and Corrigendum if any.

### 8. **Buyer Added Bid Specific ATC**

Buyer uploaded ATC document [Click here to view the file.](#)

## **Disclaimer**

The additional terms and conditions have been incorporated by the Buyer after approval of the Competent Authority in Buyer Organization. Buyer organization is solely responsible for the impact of these clauses on the bidding process, its outcome and consequences thereof including any eccentricity / restriction arising in the bidding process due to these ATCs and due to modification of technical specification and / or terms and conditions governing the bid. Any clause incorporated by the Buyer such as demanding Tender Sample, incorporating any clause against the MSME policy and Preference to make in India Policy, mandating any Brand names or Foreign Certification, changing the default time period for Acceptance of material or payment timeline governed by OM of Department of Expenditure shall be null and void and would not be considered part of bid. Further any reference of conditions published on any external site or reference to external documents / clauses shall also be null and void. If any seller has any objection / grievance against these additional clauses or otherwise on any aspect of this bid, they can raise their representation against the same by using the Representation window provided in the bid details field in Seller dashboard after logging in as a seller within 4 days of bid publication on GeM. Buyer is duty bound to reply to all such representations and would not be allowed to open bids if he fails to reply to such representations.

[This Bid is also governed by the General Terms and Conditions](#)

In terms of GeM GTC clause 26 regarding Restrictions on procurement from a bidder of a country which shares a land border with India, any bidder from a country which shares a land border with India will be eligible to bid in this tender only if the bidder is registered with the Competent Authority. While participating in bid, Bidder has to undertake compliance of this and any false declaration and non-compliance of this would be a ground for immediate termination of the contract and further legal action in accordance with the laws.

**---Thank You---**

# **General terms and conditions on GeM 3.0 (Version 1.21)**

## **1. Introduction**

This document is an electronic record published by GeM under the provisions of the Information Technology Act, 2000 and the rules made there under (as applicable) and shall act as valid agreement between Seller / Service Provider and Buyer. Further the use of GeM Portal for Sale / Purchase of Goods / Services and the **resulting Contracts shall be governed by the following General Terms and Conditions (GTC) (unless otherwise superseded by Product / Service specific Special Terms and Conditions (STC), Product / Track / Domain Specific STC of Particular Service including its SLA (Service Level Agreement) and BID/Reverse Auction Specific Additional Terms and Conditions (ATC) as applicable).**

Government e-Marketplace (GeM) is the National Public Procurement Portal; an end-to-end online Marketplace for Central and State Government Ministries / Departments, Central & State Public Sector Undertakings (CPSUs & SPSUs), Autonomous institutions and Local bodies, for procurement of common use goods & services. The portal is owned and managed by GeM SPV which is a Section 8 (Non- Profit) Company registered under the Companies Act, 2013. GeM SPV operates, monitors and supervises all the business transactions on the portal through the Managed Service Provider as per defined roles and responsibilities.

## **2. General Terms and Definitions:**

- a. **“APPLICABLE LAWS”** shall mean any statute, law, ordinance, notification, rule, regulation, judgment, order, decree, bye-law, approval, directive, guideline, policy or other governmental restriction as may be in effect.
- b. **“GOODS”** shall mean an Article / product or an intangible product like software, technology transfer, licenses, patents or other intellectual properties being offered for sale on the GeM portal by Seller(s) on GeM. The term ‘Goods’ shall also include works and services which are incidental or consequential to the supply of such goods, such as, transportation, insurance, installation, commissioning, training and guarantee / warrantee obligations as defined in the scope of supply given in the contract.
- c. **“SERVICES”** shall mean the services offered or provided by the Seller such as IT Professional Services, Manpower Services, Security Services, Transport Services, etc. listed as Services on GeM. The term ‘Service’ shall also include supply of goods / articles which are incidental or consequential to the provisioning of such Services as defined in the scope of supply given in the contract.

- d. **“SERVICE LEVEL AGREEMENT (SLA)”** shall mean the Contractual Commitment that prevails between the Buyer and the Service Provider with regard to type of service to be provided, deliverables, desired performance level, reliability and responsiveness, monitoring process and service level reporting, response and issue resolution time-frame, repercussions / penalties / remedies for service provider not meeting its commitment. The SLA of a particular contract may carry the matrix regarding the delivery of the goods and/or services and the corresponding penalties or remedies and liquidated damages as applicable.
- e. **“CATEGORY SPECIFICATION”** shall mean the framework of technical features, functional capabilities, technical properties, certifications of the items etc. in a particular category. The Specifications shall identify the key parameters defining the products with all necessary validations related to configuration, type of data, restrictions, range / allowed values, allowed units etc. Sellers as well as Buyers while offering / buying the Goods / services shall have to comply with the validation rules / restrictions provided for in the Category Specification. Buyers / Sellers can not add parameters and / or drop down values not provided for in category Specification. If any Buyer / Seller desire to add new parameter, value, validation etc. against any category specification, they have to raise request for the same to GeM for incorporation in Category Specification.
- f. **“BUYER”** is the Contract placing authority, which includes Central/State Government Ministries/Departments including its attached/subordinate offices, Central/State Public Sector Units (PSUs) and Autonomous Bodies acting through its authorized officer(s) for and on behalf of President of India/Governor of the State /PSU/Autonomous Bodies, as the case may be, for purchase of Goods/Services offered by Sellers on GeM.
- g. **“SELLER / SERVICE PROVIDER”** on GeM shall mean any legal entity such as firm(s) of Proprietorship / Partnership Firm / Limited Liability Partnership / Private Limited / Limited company / Society registered under Society’s Act / Statutory Bodies etc., registered on GeM to sell its Good(s) / Service(s) to the Buyers registered on GeM.

The “Seller on GeM” will be either OEM (Original Equipment Manufacturer\*) or Seller having authorization to sell products manufactured by the OEM in open market.

\* OEM is the owner of the Brand / Trademark of the product being offered or in case of un-registered brand’s products / products with own brand, the actual manufacturer of the final product. To be recognized as an OEM on GeM, seller has to get Vendor Assessment Report from designated agency (unless exempted as per GeM VA policy) as per due process of vendor assessment notified on GeM portal

(which would include production of documentary evidences and demonstration of manufacturing facilities and / or capabilities as required).

In case of Services related to Goods, Service Provider on GeM will be either OEM or Service Provider having authorization to Service products manufactured by that OEM in open market. In respect of other Services, Service Provider on GeM will be any legal entity offering its services.

By registering on GeM portal , Seller / Service Provider hereby agrees to be bound by these General Terms and Conditions for Sale / Purchase of Goods and / or Services (GTC); Product / Service Specific Special Terms and Conditions (STC) and Service Level Agreements (SLAs) for various Services; and Additional (Bid Specific) Terms and Conditions (ATC) as applicable.

For the purpose of this document and transactions on GeM, Seller as well as Service Provider will be referred to as “Seller”

- h. **“USER ID and PASSWORD”** All users including Buyers and Sellers (primary as well as secondary) will get User ID and Password created on GeM following due registration process defined on GeM. It is the responsibility of the user to keep their User ID and Password secure and confidential. Individual user shall be solely and completely responsible for all transactions taking place on GeM portal using his / her User Id and Password and GeM shall not be responsible in any manner.
- i. **“LICENSE”** shall mean by registering the Seller and by offering Product / Service details on GeM, the Seller grants GeM a non-exclusive, royalty-free, irrevocable, perpetual and fully sub-licensable right to use, reproduce, modify, adapt, publish, translate, distribute, and/or display the content/materials which has been submitted to GeM excluding Aadhaar No. In case of registration of Primary user and creation of secondary user(s) by the Buyer/Seller, their Aadhaar (UID) details collected by GeM are solely for user verification and to apply e-signing on the documents. The e-sign is at par with digital signatures as per Information Technology Act Amendment 2008 and it works based on details available in Aadhaar database of UIDAI and there is no interference / intrusion in their personal details.
- j. **“CONTRACT”** shall mean the purchase order created / issued by the Buyer on GeM for supply of Goods / Services in electronic form which includes scope of supply, delivery instructions and specifications etc. as ordered by Buyer against such Contract besides the subject GTC, STC/ATC as the case may be.

### **3. Role, Responsibilities and Obligations of Seller/ Buyer:**

#### **A. Role and Responsibilities of Sellers on GeM are as under:**

- i. Only Director (s) / Partner (s) / Proprietor (as applicable) are authorized to become Primary User and register any legal entity on GeM as Seller.
- ii. Once Seller/Service Provider is registered and account is created on GeM, the Primary user of the Seller/Service Provider can create Secondary User Accounts within Seller/Service Provider Organization with different Roles and Responsibilities. However, the Primary User creating Secondary User accounts shall continue to be fully responsible and accountable for all actions / transactions done by Secondary Users on GeM Portal.
- iii. Since GeM is a trust based Portal, the complete accuracy and integrity of data submitted in respect of the Seller and also in respect of the Goods / Services offered on GeM will be the sole responsibility of the Seller/Service Provider. Seller will be liable for administrative action as per GeM terms and conditions in case of any discrepancy / infirmity in any data / information submitted on GeM.
- iv. The Primary / Secondary Users of Sellers, offering Goods/Services and/or participating in e-Bidding / Reverse Auction on GeM, must ensure that they have the requisite authorization to enter into contract with Buyer(s) in GeM for and on behalf of the Seller, failing which such Seller as well as the individual(s) shall be vicariously liable for its actions and also for any liability arising out of such actions.
- v. Seller can offer any number of products. However, it will be the sole responsibility of the seller to satisfy themselves regarding possessing the requisites for doing business for the offered product(s). The Sellers are solely responsible for ensuring that there is no violation of any Intellectual Property Rights in their offer for sell / providing service on GeM.
- vi. The Seller should not exercise any corrupt influence on any aspect of contract and commit to take all measures necessary to prevent corruption maintaining complete transparency, integrity and fairness in all activities related to GeM.
- vii. The seller would represent its business on the GeM portal and is mandated to comply with all the terms and conditions of the platform. Sellers would be solely and absolutely responsible for the information provided about their organization, business, products and services on the portal and would be required to produce proof of such information, if requested at any point in time by the Buyer and / or GeM.

- viii. GeM would not allow creation of any fresh data related to Seller identity on GeM portal. All details provided by the Seller at the time of registration would be counter checked / verified through other data bases of Government such as PAN, MCA 21, Udyam Registration etc. For Financial details, PAN / Income tax Database shall be primary validating database and will override any conflicting data in any other database. If the data / details entered by the seller while registering on GeM is not verified with validating databases, registration will not be allowed. Further, in case of any conflict in details after registration, Seller's registration would be automatically suspended. It is the Seller's responsibility to keep all their information on GeM updated with the latest change(s). Non-updating of details on GeM within 7 days of such occurrence would make Seller liable for administrative actions.
- ix. Eligibility of Sellers in terms of Turn Over / Past Performance / Profitability etc. and also their eligibility for availing various benefits / advantages in terms of various Govt. Policies / Guidelines / Acts / Laws etc. shall be determined solely on the basis of data fetched / validated or verified through external agency / owner of that set of database such as Income Tax / PAN Data Base, MCA 21, Udyam Registration, GSTN, Certifying Agencies such as BIS, BEE etc. In case of any discrepancy in data available in these databases, Seller has to get the same updated in the corresponding validating database before updating the same on GeM. Till such time only the existing validated information shall be used to decide seller's eligibility on GeM. Any default in sellers updating their data on partner sites / validating databases and any fall out of the same impacting adversely any transaction on GeM, shall entirely and exclusively be Seller's responsibility. GeM shall not be responsible for any consequential impact on any GeM transaction due to data discrepancy and / or suspension of seller account due to data discrepancy. Seller will be solely responsible for the same.
- x. The Seller shall be solely responsible for the Goods / Services including, without limitation, the applicable guarantee / warranty, shelf-life, quantity, quality and the title and for giving the correct and accurate details of the offer their Goods and / or /Services indicating product specifications, quantity which can be supplied over the specified time period, etc. as per catalogue or catalogue based template prescribed in GeM. Seller would ensure that the Goods or /Services offered are latest, new and complete in all respects. Where Seller is selling any Goods which needs spare parts, Seller should ensure and make available such spare parts for a minimum period of three years from the date of expiry of warrantee period (unless otherwise specified). The individual Sellers shall ensure that the products offered in e-Bidding and/or ordered shall remain available on GeM during the bid / contract validity period.

- xi. Sellers shall offer minimum discount of 10% on the Maximum Retail Price (MRP) mandatorily (unless otherwise specified for offering their products on GeM). Sellers are free to offer higher discounts. The Seller must offer its best possible lowest price on GeM and undertake that it would not sell or offer to sell the same product outside GeM in comparable quantity on similar terms and conditions at a price equal to or lower than Offer Price on GeM. In case any such infringement by Seller is noticed, the Seller shall be liable to be removed / debarred from the GeM.
- xii. By offering their product on GeM, the Seller agrees for sharing price details of the offered Goods / Service by GeM authorities with other Government agencies including Department of Excise & Customs, Income tax, GST etc.
- xiii. Listing of Goods / Services in irrelevant / inappropriate categories is strictly prohibited. If any such infringement made by Seller leads to placement of a contract by any Buyer for such inappropriately offered product(s)/service(s) by the Seller, such contract shall be treated as null and void. No claim whatsoever against such contract shall be admissible and entertained.
- xiv. The Seller(s) shall pass on all the benefits associated with any scheme / offer / freebies provided by the OEM on any product from time to time on an "as-is basis" to the Buyer. This obligation will also apply to OEM's directly supplying the goods. Holding back any such offer or accounting such freebies in quantity supplied shall make such consignments liable to be rejected by the consignee and shall also be considered as inappropriate and against the GeM policies for which GeM reserves all rights to take necessary action against such Seller/OEM as deemed fit.
- xv. By registering on GeM and by participating in any bid on GeM, Seller undertakes that presently it is not "Debarred from Bidding" on the grounds mentioned in Rule 151 of GFR 2017.

**B. Role and Responsibilities of Buyer on GeM:**

Buyer Registration on GeM is divided in two categories:

- a. **Primary User:** In GeM, the Primary User is as under:
  - i. Any officer of Central / State Government / PSU / Autonomous Bodies / Local Bodies / Constitutional Bodies / Statuary Bodies at the level of Deputy Secretary of the Government of India or equivalent
  - ii. Head of the Office at Sub Centre / Unit / Branch, can Register his / her organization / unit on GeM portal as Primary User.

Primary User shall be responsible for registering the organization on GeM, for creating User accounts for Secondary Users, assigning them roles and responsibilities on GeM and for supervision of all transactions performed by Secondary Users under him / her.

Primary User shall also be vicariously responsible for ensuring compliance of

General Financial Rules and / or Rules Governing Public Procurement in respect of their organization, all GeM terms and conditions and other Procurement Policies / Guidelines notified by the government from time to time, by all the secondary users including timely payments and for dispute resolutions as per GeM terms and conditions.

Primary user cannot perform any Procurement related transactions on GeM portal.

- b. **Secondary Users:** Secondary Users are officials responsible for procurement transactions on GeM including Placement of Contracts, Receipt of Stores, and Payments to the Sellers etc. The access rights permissible to registered Secondary users would be decided by the Primary User of the Department. Secondary Users may be given the roles of Buyer / Consignee / Drawing and Disbursement Office (DDO) / Paying Authority etc. For transaction on GeM portal, Buyer is the official who is responsible for processing procurement transaction up to Order Placement stage. Consignee is the Secondary User in Buyer Organization responsible for certifying receipt and acceptance of the goods procured.

Buyer's responsibilities on GeM portal are as under:

- i. The Buyers are responsible to ensure that the procurement done by them are in compliance of General Financial Rules and / or Rules Governing Public Procurement in respect of their organization, all GeM terms and conditions and other procurement Policies / Guidelines notified by the government from time to time, including timely payments as per GeM terms and conditions.
- ii. The Buyers (in all capacities i.e. as Buyer, Consignee, DDO, Paying Authority etc) are responsible to ensure that the procurement done by them are in compliance with GeM Terms and Conditions / Guidelines and all contract related transactions are completed within time lines prescribed in GeM Contract.
- iii. The Buyers must ensure that they have the requisite authorization to enter into contract with Seller(s) on GeM for and on behalf of the organization, failing which such individual(s) shall be individually liable for its actions and also for any liability arising out of such actions.
- iv. While making procurement on GeM, the Buyers shall judiciously search and shortlist items using filters such as quantity, technical parameters, delivery period, warranty period, consignee location(s), Seller's eligibility etc. as per their approved requirements. Placement of contract for a product / service uploaded by the Seller in any wrong/inappropriate product category is strictly prohibited and such contracts shall be treated as null and void and such Buying shall adversely affect Buyer Rating on GeM.
- v. The Buyers shall satisfy themselves that the price of the selected offer is reasonable. Buyer is at liberty to utilize all the data / information and Business Analytics made available in GeM including e-bidding and reverse auction.

- vi. The Buyers, before placing the order on GeM, should have the required mandatory approval with prior sanction and approval of the competent authorities and shall be in compliance with and as per procedures outlined in GFR and other procurement guidelines issued by the Government from time to time.
- vii. On award of the Contract(s), it would be construed that the Buyer has obtained all necessary Administrative & Financial sanctions of the competent authority and adequate funds are available indicating the relevant Head of accounts in the awarded Contract(s).
- viii. The Buyers should not exercise any corrupt influence on any aspect of contract and commit to take all measures necessary to prevent corruption maintaining complete transparency and fairness in all activities related to GeM.
- ix. Buyers are not allowed to place any order at GeM prices outside GeM. The prices on GeM are only applicable if the procurement is made through GeM portal. Using GeM prices for procurement outside GeM portal is strictly prohibited. Further, Buyers are not allowed to place any off-line contract to the Seller directly based on the outcome of e-Bidding / RA conducted on GeM. All such contracts shall be treated as null and void and GeM reserves the right to delete all data related to such transactions from GeM database besides taking suitable actions against such Buyers including suspension from GeM and / or reduction of Buyer rating etc.

#### **4. Enabling provisions of Rule 149 of General Financial Rules- 2017**

Enabling provisions of Rule 149 of General Financial Rules- 2017 as amended vide Ministry of Finance OM dated 02.04.2019 regarding procurement through GeM and necessary guidelines and terms and conditions thereon:

GeM portal may be utilized by the Government buyers for on-line purchases as under:-

- i. Up to Rs.25,000/- through any of the available suppliers on the GeM, meeting the requisite quality, specification and delivery period.
- ii. Above Rs.25,000/- and up to Rs.5,00,000/- through the GeM Seller having lowest price amongst the available sellers (excluding Automobiles where limit of Rs.30,00,000/- will be applicable), of at least three different manufacturers, on GeM, meeting the requisite quality, specification and delivery period. The tools for online bidding and online reverse auction available on GeM can be used by the Buyer if decided by the competent authority.
- iii. Above Rs.5,00,000/- through the supplier having lowest price meeting the requisite quality, specification and delivery period after mandatorily obtaining bids, using online bidding or reverse auction tool provided on GeM (excluding Automobiles where limit of Rs.30,00,000/- will be applicable).

- iv. The Government Buyers may ascertain the reasonableness of prices before placement of order using the Business Analytics (BA) tools available on GeM including the Last Purchase Price on GeM, Department's own Last Purchase Price etc.
- v. GFR rule 149 allows direct on-line purchases on GeM up to Rs. 25,000/- through any of the available suppliers on the GeM, meeting the requisite quality, specification and delivery period. However this is subject to procuring authorities certifying the reasonability of rates. While making such direct on-line purchase below Rs. 25,000/-, the buyer should have approval of competent authority and should also record reasons for selecting the specific product in case lowest priced products are not being accepted / ordered.
- vi. Tools have been deployed on GeM portal to show the price of compared products on other e-commerce sites (wherever available) and also the rates at which orders have been placed on GeM for such items in recent past. While taking decision on reasonableness of price, the buyers may also take into account the discount over MRP; Last Purchase Price on GeM, Department's own Last Purchase Price; rates on other e-commerce websites etc. The prices on e-commerce site give a broad idea and its terms and conditions may be different. If it is found that the price available on GeM marketplace is not reasonable or is substantially higher than e-commerce sites or LPP, the GeM Portal provides tools for online bidding or reverse auction which can be used by the Buyers to get better competitive rates and then satisfy themselves about reasonableness of the price as per GFR -2017 before placement of contract. Bidding should be considered as the preferred mode of procurement above Rs. 25,000/-.
- vii. In case of Direct Purchase, during carting period, rates for carted quantity, for that buyer, are frozen for carting period as notified from time to time on GeM against any upward revision by seller. However, advantage of any downward revision in the offer price of carted item shall be automatically provided to the buyer.
- viii. According to the provisions of Rule 149 (ii) of GFR, 2017, GeM shall be utilized by Government buyers for direct on-line purchases above Rs. 25,000/- and up to Rs. 5,00,000/- however such purchase has to be through the Seller having the lowest price (L-1) amongst the available Sellers on the GeM. In order to ensure that buyers select only L-1 available offer, the GeM portal enables buyer to first compare all the product options available on GeM to ensure that it meets its requirements/ specifications. While comparing, care should be taken by the Buyer that comparison has to be done between products of at least three different Manufacturers / OEMs. For L-1 buying, comparison has to be made between products of at least three different OEMs, as per GFR. If Buyer wants to buy any specific OEM's product then he has to go for Proprietary Article Certificate (PAC) buying after obtaining necessary approvals of competent

authorities for PAC buying as per GFR-2017, as amended from time to time or the Procurement Guidelines of the respective Organisation as the case may be.

ix. **Proprietary Article Certificate (PAC) Buying:** While making procurement under PAC Buying on GeM, it is the responsibility of the Buyer to ensure that compliances with the conditions / rules as laid down under GFR, 2017, as amended from time to time or the Procurement Guidelines of the respective Organisation as the case may be is met before initiating procurement under PAC:

(a) In case a Govt. Buyer on GeM wants to make procurement on proprietary basis on the GeM Portal after obtaining the requisite approvals / PAC certificate from their competent authority as per Rule 166 of GFR-2017 or the Procurement Guidelines of the respective Organisation as the case may be, the Buyer can use PAC filter provided on GeM for selecting a specific model/ make available from a particular GeM Seller. The Buyer should ensure before procuring the goods under PAC Buying that the Proprietary Article Certificate as per the conditions laid down in GFR or the Procurement Guidelines of the respective Organisation as the case may be is available with the Buyer. It is the responsibility of the Buyer to ensure compliance with GFR or the Procurement Guidelines of the respective Organisation while procuring goods on proprietary basis through the GeM Portal including ensuring the certificate to be in proper format as per GFR or the Procurement Guidelines of the respective Organisation as the case may be.

(b) The Buyer should note that the Seller's price on the Portal is just their offer prices and the proper discovery of price generally happens through bidding/RA. Moreover, in PAC procurement irrespective of multiple listing by authorised sellers, the important issue of price control remaining with the OEM should not be overlooked. Therefore, in case of all the PAC procurements, the Buyers are advised to carry out extra due diligence in establishing the reasonableness of prices before placement of contract as per Para (vii) of Rule -149 of GFR-2017 or the Procurement Guidelines of the respective Organisation as the case may be.

(c) Except for direct buying up to Rs. 25,000/- subject to establishing the reasonableness of price, the bidding is mandatory for procurements above Rs. 25,000/- as per GFR. As result of bidding, the response could be as under:

- i. Only OEM is available or only single authorised seller is available.
- ii. OEM as well as multiple authorised Sellers are available.
- iii. Multiple authorised Sellers of the OEM are available.

(d) After bidding, under PAC buying, the Buyer may take decision with the approval of the competent authority to process the procurement subject to establishing the reasonableness of prices before placement of contract as per Para (vii) of Rule - 149 of GFR-2017 or the Procurement Guidelines of the respective Organisation as the case may be.

- x. In order to give flexibility to the buyers in sourcing their requirements through GeM, provision has been made in e-bid and RA modules for indicating delivery period in terms of “number of days from date of placement of contract”. While stipulating delivery period in their bid documents, Buyers are advised to be careful since un-realistic delivery period stipulations may result in elimination of some genuine sellers, lack of competition and may ultimately have impact on cost of procurement. While fixing delivery period in e-bid/ RA bid, buyers should not only take into consideration the quantity required and the essentiality of requirement of that quantity within stipulated time period but also the possible impact of shorter delivery period on competition in e-bidding / RA.
- xi. Splitting of demands by creating multiple Bids / RAs of same goods / services or making repeated procurements of same Goods / Services through L-1 buying as per rule 149(i) and 149(ii) of GFR-2017 are strictly prohibited on GeM. Splitting of demand deprives the organizations from achieving the best competitive prices leveraging economies of scale. It also implies avoiding the necessity of obtaining the sanction of higher authority required with reference to the estimated value of the total demand. It is a violation of Para Rule 149 (viii) of GFR -2017 and terms and conditions of GeM Portal and Buyer including the Primary Buyer shall be entirely responsible for the same. If any such splitting of demand is noticed, GeM shall have the right to take necessary action such as blocking of such Bids/RAs and / or cancelling such contracts.
- xii. GeM is a dynamic online marketplace. The product/service listings across the existing categories are dynamic. Moreover, new categories of products/services are continuously being added on GeM. In situations where there is only one offer available in a product/ service category and/or there is offer from only one Seller after filter based search, the buyer should not select such offer for buying. Efforts should be made by Buyer to get their past suppliers and prospective Sellers on-boarded on GeM so as to ensure availability of sufficient Sellers on GeM. This however will not apply for PAC procurement.

**xiii. e-Bidding and Reverse Auction (RA) on GeM**

- (a) The e-Bidding / RA module of GeM is a tool provided to the Buyer(s) for organizing bidding / RA from GeM Sellers of the particular product category for a pre-defined requirement i.e. quantity, technical parameters for Goods/ Services of the particular product category required for one or more Buyers / Consignees.
- (b) Prior to initiating e-Bidding / RA, the Buyer shall judiciously search and shortlist item among the items offered on GeM using filters such as quantity, technical parameters, warranty period, consignee location(s) etc. as per the requirement. In case the search made using actual quantity required, fails to identify sufficient offers, the Buyer may use an indicative quantity for initial search and selection of product and quantity may be

amended to match the actual requirement at the time of finalizing e-Bidding / RA.

- (c) The technical parameters and warranty of the item identified by the Buyer shall be base parameters of the item for conducting e-Bidding / RA for the required Goods/Services.
- (d) The e-Bidding / RA document will be finalized by the Buyer(s) by stipulating requirements such as Quantity, Consignee Details, Terms of Delivery, Delivery Period, EMD, Performance Bank Guarantee, Time & Date for Start and End of Bid Submission and for Opening of Bids and required Bid Validity period etc. GeM system shall decide Start / Reference Price and Step Value of Decrement in case of RA based on product selection and / or outcome of bidding process.
- (e) The e-Bidding / RA invitation / Notice shall be published on GeM, stipulating the last date for bid submission / opening of bids giving at least clear 10 days time after the publication. Any change in last date for bid submission will be intimated to eligible bidders through e-mail / GeM. The e-Bidding invitation shall be extended to all the registered Sellers on GeM who have Goods / Services for that particular category listed on GeM, at least 2 hours prior to closing time of e-Bidding / RA. The GeM normally requires 48 hrs for approval / rejection of the product / service offered by Sellers before it is listed on the portal. Considering these time lines, the Sellers are required to offer their Goods / Services on GeM well in advance before bid closure. The decision of the Buyer/GeM regarding technical/commercial eligibility of the individual Seller to be invited for e-Bidding / RA shall be final.
- (f) The Seller participating in the e-bidding / RA may offer any one of their product(s) already listed on GeM. The bid submitted under e-Bidding / RA shall remain valid for 15 days (or as stipulated by the Buyer in the bid document) from the Bid Opening Date (till 24.00 Hrs IST). Bid Validity can be further extended with mutual consent between Buyer and Seller. The products offered in e-Bidding / RA can not be withdrawn by the Sellers from GeM during the bid validity period. The Buyer reserves the right to postpone/cancel the e-bidding and intimation thereof will be sent by e-mail / GeM to the Bidders. Any amendment / corrigendum to the e-bid invitation issued by the Buyer will be made online and shall be uploaded on the GeM. The participation by the Seller in e-bidding shall be construed as his / her acceptance for all the Terms and Conditions as outlined in the e-bidding including GTC, STC and ATC. However, the Buyer

shall have right to decide the technical and commercial acceptability of the individual bids based on eligibility criteria and compliances as stipulated in the bid document. The technical parameters shown in the bid are from a particular catalogue as selected by the buyer while applying initial filters in selection of the product. The sellers are free to bid for same, equivalent or superior specifications catalogue / products. In the public interest, buyers will evaluate such bids based on their requirements / end use and bid parameters and will accordingly technically accept or reject the bids on merits.

- (g) In bid documents, Buyers can incorporate suitable eligibility criteria and additional terms and conditions only using various filters and ATC module available in e-bidding / RA modules of GeM. Buyers are not allowed to incorporate eligibility criteria and / or additional / special terms and conditions exterior to the GeM portal by making reference to any other website / documents etc.
- (h) In case, two or more acceptable bidders are found to have quoted identical lowest bid price, Buyer has to conduct Reverse Auction for the required Goods among all technically qualified bidders in case of bids for Goods. In case of Services bids, if the multiple L-1 bidders have quoted the lowest allowed price for that service, Buyer shall have two options for placement of Contract:
  - a) Placement of contract by selection of an agency from amongst the L-1 bidders through a Random Algorithm run by GeM system.
  - b) Placement of contract on any one of the L-1 bidders based on any criteria as deemed fit by the Buyer with appropriate internal approvals
- (i) The Buyer reserves the right to accept/reject any bid including the lowest bid received through e-bid and/or annul the e-bidding process.
- (j) The participating bidders shall not disclose details of their bids or other details of their e-bids to other bidders or indulge in any anti-competitive behaviour including price manipulation in violation of Competition Act, 2002.
- (k) The Buyer/GeM will not be held responsible for consequential damages such as no internet connection, no power supply, system problems, loss of electronic information, power interruption etc.
- (l) Against any bidding or RA conducted on GeM, if a bidder quotes Nil Charges/consideration, the bid shall be treated as non-responsive and will not be considered.

(m) There shall be no EMD for Bids / RA having estimated value less than Rs. 5 lakh. For bids / RA having estimated value more than Rs 5 Lakh, while finalizing e-Bid / RA, Buyer shall indicate the exact amount of EMD required to be submitted by bidders in the form of Bank Guarantee on GeM portal in the prescribed format. Scanned copy of the same shall be uploaded by Seller in the online bid and hard copy of the same will have to be submitted directly to the Buyer within 5 days of bid opening. GeM recommends quantum of EMD @ 1% of estimated value of procurement. The Buyer also has the option to select EMD between 0.5% to 5%. The same should be valid for 45 days beyond the bid validity. Following categories of Sellers shall however, be exempted from furnishing EMD:

- i. Micro and Small Enterprises who are manufacturer of the Primary Product Category or Service Provider of the Primary Service Category and give specific confirmation to this effect at the time of bid submission and whose credentials are validated online through Udyam Registration and through uploaded supporting documents.
- ii. Start-ups as recognized by Department of Industrial Policy and Promotion (DIPP).
- iii. KVIC, ACASH , WDO, Coir Board, TRIFED and Kendriya Bhandar.
- iv. Sellers who have got their credentials verified through the process of Vendor Assessment by Vendor Assessment Agencies for the Primary Product / Primary Service for which Bid / RA has been invited.
- v. Sellers/ Service Provider having annual turnover of Rs 500 Crore or more.
- vi. Micro and Small Enterprises registered with NSIC for the Primary Product Category whose credentials are validated through NSIC database and through uploaded supporting documents.
- vii. Micro and Small Enterprises registered with DIC for the Primary Product Category whose credentials are validated through DIC database and through uploaded supporting documents.

- viii. Sellers / Service Providers holding BIS License for the Primary Product Category whose credentials are validated through BIS database and through uploaded supporting documents.
  - ix. Central / State PSUs.
  - x. Seller / Service Provider registered with designated Agency / Authority as specified in the bid document by the Buyer – such bidder shall have to upload scanned copy of relevant registration document in place of EMD document while bidding.
- (n) EMD submitted by the bidder shall be forfeited, if the bidder:
- i. Withdraws or modify or impairs or derogates from the bid in any respect within the period of validity of its bid; or
  - ii. If it comes to notice that the information / documents furnished in its bid is false, misleading or forged; or
  - iii. Fails to furnish requisite performance security / PBG within stipulated time required as per e-bid / RA conditions.
- (o) Notwithstanding above, GeM SPV / GeM Admin also reserve the right to debar such seller from GeM portal. Such debarment shall be for minimum 3 months initially on first such offence and on repeat offence, the debarment period can be increased suitably by GeM SPV / GeM Admin. By submitting a bid on GeM, the Bidder explicitly undertakes to abide by the above clause.
- (p) Earnest money of unsuccessful bidders shall be returned within 15 days after the award of contract or expiry of bid validity whichever is earlier. Earnest money of successful bidder shall be returned within 15 days after receipt of Performance Security / e-PBG.
- (q) In case of RA, Start / Reference Price and Step Value of Decrement shall be indicated to the Bidders at the start of the auction. Any participating bidder can bid one or multiple Step Decrement lower than the prevailing Lowest Bid at that time.
- (r) The Bidder shall be able to view Bid Start Price, Bid Decrement Value, Prevailing Lowest Bid value and last Bid Placed by him. Whenever a lower price bid is received in the closing moment i.e. within 15 minutes of existing end time of Reverse Auction, the end time of reverse auction shall be extended automatically by another 15 minutes. All participant sellers of that RA shall be notified by the GeM system about extension of time through email and/or SMS and they shall be allowed to submit revised bid under the RA. The same process shall be repeated, if there is

another lower bid received in the RA during last 15 minutes of RA.

(s) GeM / Buyer shall not have any liability to bidders for any interruption or delay in access to the GeM site / Reverse Auction link etc, irrespective of the cause.

(t) By creating a bid on GeM, the Buyer undertakes as under:

"I confirm that this tender document complies with the "Public Procurement (Preference to Make in India) Order, 2017, as amended from time to time" issued by DIPP and "Public Procurement Policy for Micro and Small Enterprises (MSEs) Order, 2012, as amended from time to time " issued by MoSME".

(u) **Bid to RA:** While creating bid on GeM, Buyer shall have the provision to select Bid to RA option. If this option is selected by the Buyer at the time of bid creation, Sellers would be required to submit their Technical and Commercial bids before bid closure. After completion of technical evaluation by the Buyer, Reverse Auction would be conducted amongst first 50% of the technically qualified bidders arranged in the order of prices from lowest to highest. Number of sellers eligible for participating in RA would be rounded off to next higher integer value if number of technically qualified bidders is odd (e.g. if 7 bids are technically qualified, then RA will be conducted amongst L-1 to L-4). In case number of technically qualified bidders are 2, RA will be between both without any elimination.

In case Primary products of only one OEM are left in contention for participation in RA based on lowest 50% bidders qualifying for RA, the number of sellers qualifying for RA would be increased to get at least products of one more OEM (directly participated or through its reseller) if available. Further, if bid(s) of any seller(s) eligible for SME preference is / are coming within price band of 15% of L-1 or if bid of any seller(s) eligible for Make in India preference is / are coming within price band of 20% of L-1, then such SME / Make in India seller shall also be allowed to participate in the RA process. After the RA process, the award of contract(s) shall be made by the buyer keeping in view the Public Procurement Policy for Micro and Small Enterprises (MSEs) Order, 2012 and Public Procurement (Preference to Make-in-India) Order, 2017 last revised on 29.5.2019 as amended from time to time.

(v) In case any Seller / Service provider has been debarred in any particular Department / Organization, Buyers of that particular Department / Organization only shall have the right to disqualify

such Sellers / Service providers at the time of technical evaluation of Bids during the period of debarment, subject to the condition that orders of such debarment has been taken with approval of Competent Authority of that Department / Organization and has been communicated to the concerned Seller / Service Provider before bid opening date.

- (w) GeM is an end to end on-line procurement portal and not a tender publishing portal. GeM has detailed GTC, product / service specific STC and a rich ATC library in-built in the portal which can be used to create a comprehensive bid document. Based on the available terms and conditions, there is hardly any need to add any additional conditions to be attached with any GeM bid. However, for inclusion of some clause which is considered absolutely necessary for that particular bid for reasons to be explained in detail, a provision for inclusion of additional conditions in the bid through corrigendum is available in Request Management System. Only indispensable conditions that are not covered in and are not in conflict with GeM GTC, Product / Service STC and the standard ATC library, and which are in compliance with the Govt. orders on Public Procurement and are not restrictive and not against the core principals of transparency, fairness and efficiency enshrined in GeM, can be requested through RMS ATC request for making part of GeM bid through corrigendum. Each such request has to be made only after due approval of the Competent Authority in Buyer Organization confirming that the request has been made with the approval of the Competent Authority. Buyer organization shall be solely responsible for the impact of the requested clauses on the bidding process and its outcome. The clauses which are already covered in standard ATC library available on GeM Portal, will not be allowed through RMS.
- (x) Determination of eligibility in case of products requiring BIS License: In case the bid requires availability of BIS License, bidder has to upload currently valid and operative BIS License copy (Valid on the date of bid opening) to be considered eligible. Submitted BIS License may be in the name of Bidder / OEM or in the name of the Manufacturer to whom the OEM has outsourced manufacturing of his brand of product. The name of the Brand of the offered product should be mentioned in the BIS License. BIS certificate issued under Compulsory registration Scheme for electronic products to OEM/Brand owners for the products marketed under their brand name wherein their products are manufactured at third-party manufacturing unit is valid and is

allowed for participation in the bids floated on GeM. The Manufacturer's Authorization in all such cases wherein the manufacturing is done by a third party shall be issued by the Brand owner / OEM and not by the third-party manufacturing unit mentioned in the BIS certificate.

- (y) **Bid Splitting:** In case of critical / vital / safety / security nature of the item, and / or large quantity under procurement and / or urgent delivery requirements and / or inadequate vendor capacity, Buyer may decide to have more than one source of supply. In such cases Buyer may opt for Bid Splitting while creating the bid on GeM, clearly indicating the Bid Splitting ratio in which order will be split among L-1, L-2, L-3 etc as per ratio of splitting pre-disclosed in the bid . After technical and financial evaluation, before splitting the quantity, it should be ensured by the Buyer that the L1 price is reasonable. After deciding the acceptable reasonable price, L1 would be awarded contract for at least the first / highest percentage indicated in the bid splitting ratio. For the rest of the bid quantity, the L-1 rates / lowest accepted rate will be counter offered to the next higher quoting bidder(s) for price matching. On acceptance of the counter offer, the order will be placed on next higher quoting bidder(s) for the respective percentage. In case of non- acceptance of the counter offer by the next higher quoting bidder(s), a similar offer shall be made to L3 and L4, and so on. In case counter offered rates are not accepted for ratio of splitting quantity as per bid document by any of the subsequent bidders, the left over quantity will be divided between bidders who have accepted the rates in the ratio of their originally allocated quantities subject to their confirmation and after getting consent on mutually agreed delivery schedule for the additional quantity.

## 5. Contract(s):

Following documents shall be construed to be part of the contract generated through GeM:

- i. Scope of supply including price as enumerated in the Contract Document.
- ii. General Terms and Conditions (GTC).
- iii. Product / Service specific Special Terms and Conditions (STC).
- iv. Product / Track / Domain Specific STC of Particular Service including its SLA (Service Level Agreement)
- v. Bid / RA specific Additional Terms and Conditions (ATC).

The Terms and Conditions stipulated in STC & SLA will supersede those in GTC and Terms and Conditions stipulated in ATC will supersede those in GTC and STC in case of any conflicting provisions.

## 6. Prices:

- i. **Offer price on GeM portal:** The prices of the offered Goods or Services shall be firm and fixed at any point of time and shall be indicated in INR for each accounting unit. The Seller can choose to offer Goods or Services with uniform all inclusive unit price for deliveries at locations across India on All India basis or for specified locations selected at the time of product listing. As such, for supply of Goods contract, no additional charges such as local levies / transportation / loading unloading charges etc., shall be payable over and above the contract price. For selected freight intensive products, as notified on GeM, the Seller may quote unit price inclusive of GST with delivery charge(s) (including transportation, loading unloading and local levies) payable extra as defined in the relevant categories. In respect of items requiring installation and / or commissioning and other services (as indicated in technical details of the item), the charges for the same shall also be included in the offered price on GeM.

Once a Buyer carts a particular quantity of offered Goods / Service, during carting period as notified from time to time on GeM, rates for carted quantity, for that buyer, are frozen for the period as specified on the portal against any upward revision by seller. However, advantage of any downward revision in the offer price of carted item shall be automatically provided to the buyer.

- ii. **Offer price in e-bidding:** Bidder is required to indicate offer price in the price schedule as provided in the bidding document. Complete breakup of price as required must be indicated. However evaluation of the bid shall be on the basis of total all inclusive, landed price at consignee destination (unless otherwise specified in the ATC).
- iii. **Offer price in RA:** Bidder is required to indicate total offer price. Evaluation of the bid shall be on the basis of total all inclusive, landed price at consignee destination (unless otherwise specified in the ATC). Successful bidder shall have to provide complete breakup of the quoted price in the required price bid format before award of contract.

## 7. Performance Security and Performance:

- i. *There shall be no Performance security / PBG requirement for contracts:*
  - a) *Placed under Direct Purchase / L-1 Purchase Option under Para (i) and (ii) of GFR rule 149;*
  - b) *Placed through Bids / RA with estimated bid value up to Rs 5 Lakh (in case of Goods contracts); and*
  - c) *Placed through Bids / RA with estimated bid value up to Rs 5 Lakh (in*

*case of Services contracts)*

- ii. In case of contracts placed following e-Bidding / RA, Performance Security / Performance Bank Guarantee (PBG) (in format provided on GeM) valid for 2 months beyond the date of completion of all contractual obligations including warrantee obligations, will be obtained from the successful Bidder, for ensuring due performance of the contract. GeM recommends quantum of Performance Security @ 2% of the value of contract. The Buyer also has the option to select Performance Security between 2% to 10%. While finalizing e-Bid / RA, Buyer shall indicate the % of Performance Security required to be submitted by successful bidders. In case of any extension of contract obligation period, the seller shall be liable to suitably extend the validity of the Performance Security.

Such Performance Bank Guarantee, in prescribed format, from a scheduled commercial bank must be submitted by Seller to the Buyer within 15 days of award of contract on GeM. The payments to the seller shall become due only after receipt of Performance Bank Guarantee by the Buyer and verification of its genuineness.

If the Seller fails or neglects to observe or perform any of his obligations under the contract it shall be lawful for the Buyer to forfeit either in whole or in part, the Performance Security furnished by the Seller.

If the Seller duly performs and completes the contract in all respects the Buyer shall, refund the Performance Security to the Seller within 30 days of completion of all contractual obligations by the Seller.

## **8. Duties & Taxes:**

- i. Offer Prices on GeM shall be on all inclusive basis i.e. including all taxes, duties, local levies / transportation / loading-unloading charges etc. In the case of Bid / RA, complete break-up of the quoted price in the required price bid format shall be furnished by the Bidder, before award of contract.
- ii. Statutory variation in the rate of GST, taking place between the date of award of contract and the original / refixed delivery period, shall be to the Buyer's account. For claiming any change in price due to such Statutory variation, the seller shall have to lodge claim before the Buyer providing documentary evidence of change in rate of GST taking place after the date of award of contract and the date of supply within the original / refixed delivery period. Buyer shall issue necessary amendment in the contract to enable generation of supplementary invoice or revised invoice as the case may be.
- iii. No increase in price on account of statutory increase in the rate of GST taking place during the period of delivery period extension with liquidated Damages shall be admissible. Nevertheless the Buyer shall be entitled to the benefit of any decrease in price on account of reduction in GST taking place during extended delivery period.

- iv. The Bill Form / On-line invoice shall be generated by the Seller which may inter-alia include the following confirmations from the Seller:
- a. Certified that the Goods and Services Tax (GST) charged on this Bill is not more than what is payable under the provision of the relevant Act or the Rules made there under.
  - b. Certified that the goods on which GST has been charged have not been exempted under the GST Act or the rules made there under and the charges on account of GST on these goods are correct under the provisions of that Act or the Rules made there under.
  - c. Certified that the Seller is registered with above indicated GSTIN as dealer in the State where in their Billing address is located for the purpose of GST.
  - d. The on-line bill form / invoice generated on GeM is not a replacement for the GST invoice. The proper GST invoice as per requirements of GST rules shall be sent by the seller to the buyer / consignee directly along with the Goods / Services as and when deliveries are made to the consignee.
- v. Seller shall comply with all the necessary statutory compliances including but not limited to providing GST invoices or other documentation as per GST Law relating to the supply of Goods or Services, uploading the details of the invoices, payment of taxes, timely filing of valid statutory returns for the tax period in the GST portal. In case the Input Tax Credit of GST is denied or demand is recovered from Buyer on account of any act/ omission of the Seller in this regard, the Seller shall be liable in respect of all claims of tax, penalty and / or interest, loss, damages, costs, expenses and liability that may arise due to such non-compliance. Buyer shall have the right to recover such amount from any payments due to the Seller or from Performance Security, or any other legal recourse from the said Seller. If any tax is required to be paid by the Seller in pursuance of any demand from tax authorities, on account of Seller's suppression of facts, fraud or wilful misstatement of facts while offering the products or submitting the bids, then the same shall not be passed on to Buyer through debit notes or Invoices or Supplementary Invoices and the seller shall be solely liable for payment of the same.

## **9. Integrity Pact:**

All the Users in GeM i.e. Seller as well as Buyer agree not to indulge in any corrupt practices including without limitation any activity or action to influence the transaction on any aspect of contract and commit to take all measures necessary to prevent corruption maintaining complete transparency and fairness in all activities related to GeM. Users agree to follow and adhere with the Integrity Pact guidelines provided on GeM Portal.

## **10. Guarantee And Warrantee:**

- i. The Goods/Services supplied under the Contract(s) shall be in accordance with the contract specifications & quality and the Goods shall be brand new and have standard Guarantee/Warrantee for one year period from the date of final acceptance by the consignee unless otherwise specified in category specifications, specific Bid/RA . Seller, at the time of listing their product on GeM portal or offering their products against any Bid / RA, may accordingly provide longer Guarantee/Warrantee period (i.e. more than 1 year) and in such case, Guarantee/Warrantee period stipulation made in category specifications / Bid / RA document, shall prevail over standard Guarantee / Warrantee period of 1 year stipulated in these General Terms and Conditions.
- ii. Notwithstanding the fact that the Buyer or its Quality Assurance Officer may have inspected and/or approved / accepted the said Goods, it is further guaranteed that if during the said guarantee / warrantee period, the Goods be discovered not to conform to the requisite description and quality and/or not giving satisfactory performance or have deteriorated, and the decision of the Buyer in that behalf shall be final and binding on the Seller and the Buyer shall be entitled to call upon the Seller to rectify and/or replace the Goods or such portion thereof as is found to be defective by the Buyer within 7 days. Otherwise, the Seller shall pay to the Buyer such compensations that may arise by reasons of the warranty therein contained. In cases requiring Spares, the Seller guarantees that they will supply Spare Parts, if and when required on agreed basis for an agreed price for a minimum period of three years from the date of expiry of warrantee period (unless otherwise specified in STC / ATC). The agreed basis could be, including but without any limitation, an agreed discount on the published catalogue or an agreed percentage of profit on the landed cost. The aforesaid provisions made specifically for Goods, shall also be applicable for Services to the extent the same are practically possible.

## **11. Buyer / Consignee's Right Of Rejection (Return Policy):**

- i. The Goods delivered shall bear the self certified Manufacturer's/Seller's Warranty/Guaranty. Buyer / Consignee shall have the right to inspect the supplied Goods themselves and/or through their appointed agency at consignee's own cost, at Consignee's site(s) after receipt and accept or reject on proper justification any consignment of the Goods received within a period of 10 days (unless otherwise specified in STC or ATC) of receipt of consignment of goods. The date of receipt shall be reckoned from the date of receipt of the Goods as notified in the Provisional Receipt Certificate (PRC) which will be issued online by consignee immediately after receipt of Goods.
- ii. In case of Service contract, the Buyer reserves right to reject the same in conformance with the terms and conditions of the agreed Service Level Agreement

(SLA). However, such right to reject services offered by the Seller under the contract shall be exercised by the Buyer within 10 days (unless otherwise specified in STC or ATC) of the date of receipt of the Service. The date & time of start and completion of the Service, shall be indicated by the Seller while raising on-line invoice for a specified period of Service as per Service Level Agreement (SLA). The date of such invoice or the date of completion of the service, whichever is later shall be reckoned as date of receipt of the Service.

- iii. On Acceptance / Part Acceptance or Rejection of Goods / Services, Consignee will issue an on line 'Consignee's Receipt cum Acceptance Certificate' (CRAC), which will form the basis of Payments to the Seller.
- iv. No payment shall be made for rejected goods or services. After intimation of the rejection / part rejection by the Buyer/ Consignee, the Seller shall be liable to remove / lift back such rejected Goods within 10 days without any extra charge/cost to the Buyer / Consignee failing which suitable ground rent / warehousing charges would be payable by the Seller to the Buyer /Consignee.If the Seller fails to remove / lift back such rejected Goods within reasonable time period, the Buyer / Consignee shall have the right to dispose off such rejected goods at the risk and cost of the seller.

## **12. Payment Authority and Payment Terms:**

Payments shall be made to the Seller in the manner below:

### **i. For Goods :**

In case of goods, 100% payment will be released within ten (10) days of issue of consignee receipt-cum-acceptance certificate (CRAC) and on-line submission of bills unless otherwise specified in STC / ATC.

### **ii. For Services:**

In case of services, 100% payments on the basis of monthly (unless otherwise specified) bills will be paid within ten (10) days of issue of consignee receipt- cum-acceptance certificate (CRAC) and on-line submission of bills unless otherwise specified in STC / ATC.

## **13. Terms of Delivery:**

All the Goods or Services in the GeM shall be offered on Free Delivery at Site basis including loading/unloading. In respect of items requiring installation, commissioning and other services in the scope of supply (as indicated in respective product category specification / STC / ATC), the cost of the same shall also be included in the offer price.

## 14. Delivery Period

Seller shall indicate the quantity which can be supplied over the specified time period(s). The Seller would offer these details, which would constitute the part of the awarded Contract(s) in the GeM and would make a binding Contract between the Seller & the Buyer. Any modification thereto shall be mutually agreed and incorporated in the Contract. This Delivery Period/Time shall be deemed to be essence of the Contract and delivery must be completed not later than such date(s).

## 15. Extension of Delivery Period and Liquidated Damages:

Buyer may, on the request of the Seller or otherwise, extend the delivery date suitably subject to the following conditions:

- i. The original Delivery Period may be re-fixed by the Buyer without any Liquidated damages subject to Force Majeure conditions mentioned below and also on the ground/reasons of delay attributable to the Buyer / Consignee.
- ii. For other cases, provided the price trend is not lower, the Delivery Period may be suitably extended for which an amount equal to the Liquidated Damages for the extended period(s) for delay in the supply of the Goods/Services after the expiry of contract delivery period /re-fixed delivery period, shall be recovered from the Seller as mentioned hereinafter for the extended period.No increase in price on any ground after the original/re-fixed delivery date shall be admissible during such extended period(s). Nevertheless the Buyer shall be entitled to the benefit of any decrease in price on account of reduction in GST taking place during extended delivery period.
- iii. **Liquidated Damages:** If the Seller/Service Provider fails to deliver any or all of the Goods/Services within the original/re-fixed delivery period(s) specified in the contract, the Buyer will be entitled to deduct/recover the Liquidated Damages for the delay, unless covered under Force Majeure conditions aforesaid, @ 0.5% of the contract value of delayed quantity per week or part of the week of delayed period as pre-estimated damages not exceeding 10% of the contract value of delayed quantity without any controversy/dispute of any sort whatsoever.
- iv. **Force Majeure Conditions :**

If at any time during the continuance of the Contract, the performance in whole or in part by either party of any obligation under this Contract shall be prevented or delayed by the reasons of any war, hostility, acts of the public enemy, epidemics, civil commotion, sabotage, fires, floods, explosion, quarantine restrictions, strikes, lockouts or act of God provided notice of happening of such event duly evidenced with documents is given by one party to the other within 10 days from the date of occurrence thereof, neither party shall be by reasons of such event, be entitled to terminate the Contract nor shall either party have any claim for damages against the other in respect of such non-performance or the delay in performance, and deliveries under the contract shall be resumed as

soon as practicable after such event has come to an end or ceased to exist, and the decision of the Buyer as to whether the deliveries have been so resumed or not, shall be final and conclusive, Provided further that if the performance in whole or part of any obligation under this contract is prevented or delayed by reason of any such event for a period exceeding **10 days**, either party may at its option terminate the contract provided also that the Buyer shall be at liberty to take over from the Seller at a price to be fixed by Buyer, which shall be final, all unused, undamaged and accepted material, bought out components and Goods in course of manufacture in the possession of the Seller at the time of such termination or such portion thereof as the Buyer may deem fit excepting such materials, bought out components and Goods as the Seller may with the concurrence of the Buyer elect to retain.

## **16. DISPUTE RESOLUTION BETWEEN THE BUYER AND THE SELLER / SERVICE PROVIDER**

### **16.1 AMICABLE SETTLEMENT:**

- i. The Parties (i.e., the Buyer and the Seller/ Service Provider) undertake that any conflict or dispute that may arise between them shall first be dealt with in the manner stated below, irrespective of any other recourse, which any Party may have in law or in equity.
- ii. In the event of any conflict or dispute arising out of or in connection with the Contract placed through GeM, the Parties shall endeavor to settle such disputes amicably. If a dispute is not resolved within 30 (thirty) days after a written notice of any dispute by one Party to the other, the same shall then be resolved through the mechanism of a Dispute Resolution Committee. This Dispute Resolution Committee shall comprise of representatives of both the Buyer and the Seller / Service Provider and shall be chaired by the Primary User of the Buyer organization/department or any other person as authorized by the Primary User. If the Dispute Resolution Committee is not able to resolve the matter within 30(thirty) days of its formation, the dispute shall then be referred to Arbitration.

### **16.2 ARBITRATION:**

In the event of any conflict / dispute arising out of or in connection with the Contract placed through GeM, which has not been resolved in accordance with the procedure laid down in Clause 16.1 above, the aggrieved Party may invoke Arbitration by sending a written notice to the other Party. The procedure for appointment of the Arbitral Tribunal shall be as follows.

- i. In cases where the total value of the Contract is less than INR 1,00,00,000/- (Indian Rupees One Crore only) the same shall be referred to a sole arbitrator mutually appointed by both the Parties.
- ii. Where the total value of the Contract exceeds INR 1,00,00,000/- (Indian Rupees One Crore only), the arbitration shall be conducted by a quorum of three arbitrators. Each party shall be entitled to appoint an arbitrator and the two party-appointed arbitrators shall within 30 (thirty) days from their nomination, appoint a third arbitrator i.e., the Presiding Arbitrator.

- iii. In case of failure to appoint the Presiding Arbitrator within a period of 30 (thirty) days from the date of nomination of the two arbitrators by the respective parties, the aggrieved party shall approach the High Court (under whose jurisdiction the principal place of business of the Buyer department/ organization is located) to appoint the Presiding Arbitrator as per the provisions of the Arbitration and Conciliation Act, 1996 (as amended up to date).
  - iv. The arbitration shall be conducted in the English language. Arbitration proceedings can also be conducted online, as per the discretion of the Arbitral Tribunal.
  - v. The cost of the Arbitration shall be equally borne by both the Parties.
  - vi. The award of the arbitrator shall be final and binding on the Parties to the Contract. The arbitration shall be governed by the Arbitration and Conciliation Act, 1996, as amended up to date. The seat of arbitration shall be at the place where the principal place of business of the Buyer department / organization is located.
  - vii. The Contract shall be interpreted and governed in all respects in accordance with the laws of India. All disputes in connection with or arising out of the Contract, shall be subject to the exclusive jurisdiction of the Court within the local limits of whose jurisdiction principal place of business of the Buyer department / organization is located.
- 16.3** Both the Parties understand and agree that GeM being an Intermediary cannot be made a party to any dispute in connection with or arising out of the Contract and/or the arbitration proceedings between the Parties

**17. Laws Governing the Contract:**

- i. The contract shall be governed by the laws of India for the time being in force.
- ii. Irrespective of the place of delivery, the place of performance or the place of payment under the contract, the contract shall be deemed to have been made at the registered address of the Buyer and / or Primary Buyer.
- iii. Jurisdiction of Courts: The courts of the place from where the contract has been made shall alone have jurisdiction to decide any dispute arising out of or in respect of the contract.
- iv. GeM SPV would not be a party to any such litigation.
- v. In case any Seller / Service provider makes GeM a party / respondent in any case involving any dispute between Buyer and Seller arising out of a concluded contract or arising out of bidding process initiated / concluded by the Buyer on GeM, it would be obligatory on the part of the Buyer to represent GeM also through their Counsel / Lawyer in the proceedings before the legal authority and ensure timely filing of replies / affidavits etc provided by GeM also through their Counsel / Lawyer before the concerned legal authority during the course of litigation. A standard reply on behalf of GeM, covering following aspects shall be incorporated in all replies / affidavits filed by the Buyer in such cases:

*“Government e-Marketplace is a National Public Procurement Portal; an end-to-end online Marketplace for Central and State Government Ministries / Departments, Central & State Public Sector Undertakings (CPSUs & SPSUs), Autonomous institutions and Local bodies, for procurement of common use goods & services. Prima facie, the dispute in the present case appears to be between the Buyer and Seller arising out a contract placed / bid created by the Buyer on Government e-Marketplace. As per Clause 16, Clause 17 and Clause 22 of the General Terms and Conditions of Government e-Marketplace (duly accepted by the Buyer and Seller), GeM is not to be made a party to any dispute between the Buyer and the Seller. As such Government e-Marketplace is liable to be deleted from the array of parties.*

*In light of the above, we request your goodself to kindly delete Government e-Marketplace from the array of parties.”*

### **18. Limitation of Liability:**

Notwithstanding anything contained in this agreement, no party will be liable for any special, incidental or consequential damages arising out of or in connection with this agreement or any breach hereof (including for loss of data or profits, or cost of cover), whether or not such party has been advised of the possibility of such damages, and whether under a theory of contract, tort (including negligence) or otherwise; except for liabilities arising out of any violation, misappropriation or infringement of a party’s intellectual property rights, or from a breach by either party of its obligation. In no event will either party’s aggregate liability arising out of or in connection with this agreement or any breach hereof (whether under a theory of contract, tort (including negligence), warranty or otherwise) exceed the Contract Price entered into the Contract between Buyer and Seller.

### **19. Termination for Default:**

If the Seller does not perform its obligations within the Delivery Period/Date mentioned in the Contract, the same would constitute the breach of the Contract and the Buyer shall have the right to Cancel or withdraw the Contract for the unsupplied portion after the expiry of the original or re-fixed delivery date or period stipulated in the Contract. Such cancellation of contract on account of non - performance by the Seller would entitle the Buyer to forfeit the performance security besides other actions such as downgrading the Seller’s rating or debarment from the GeM for specified period as decided by GeM on merits.

### **20. Closure of Transaction:**

After satisfactory completion of all the obligations under the Contract and release of payments for the goods / services, the transaction shall be treated as closed.

## 21. Grounds for Administrative Action

(i) Administrative actions may be taken by GeM against the Buyer or the Seller either suo-moto on the basis of the platform mechanisms identified through analytics or on the basis of a complaint or report made to GeM by any stakeholders or any third party information or upon Court order, inter –alia, for non-adherence to the GeM Website Policies including Terms and Conditions and the Incident Management Policy published on the GeM Website.

(ii) The Seller would be liable for administrative actions such as suspension / debarment / removal from GeM, if they fail to abide by any of the Website Policies including the terms & conditions stipulated in this document and/or on anyone or more of the following grounds:

- (a) Listing the products/services not in the relevant categories and/or listing the same with vague/conflicting product specifications/details and irrelevant product photographs.
  - (b) Offering Goods / Services without having proper authorization
  - (c) Supplies goods of inferior/ substandard quality
  - (d) Supplies or offers to supply refurbished or counterfeit or fake products
  - (e) Withdraws or modify or impairs or derogates from the bid in any respect within the period of validity of its bid;
  - (f) Seller furnishes inaccurate, false, misleading or forged or fails to furnish any information / documents, within the prescribed time limits, to GeM or to a Buyer, including during e-Bidding/RA process;
  - (g) Fails to furnish requisite performance security / PBG within stipulated time required as per e-bid / RA conditions;
  - (h) Fails to update GeM about any change in information furnished within the prescribed time limits;
  - (i) Executes services without conforming to requirement given in Service Level Agreement (SLA);
  - (j) Fails to execute an order/ contract or fail to execute it satisfactorily
  - (k) Is declared bankrupt or insolvent;
  - (l) Fails to produce the requisite documents/ information during the course of inspection / assessment at any stage;
  - (m) Performs any activity which is listed as prohibited activities on GeM.
  - (n) On any other ground for which, in the opinion of GeM, the retention of the seller or any of its offered product in GeM is not in Public Interest.
  - (o) The grounds mentioned above are illustrative only. Users are also advised to read the list of prohibited activities published on the website.
- (iii) Notwithstanding anything contained in the GTC, GeM reserves the right to cancel or annul the registration of any Seller or remove any of the Good/Services listed by a Seller on the GeM Website to comply with

- any provision of the Applicable Laws and / or Court Orders.
- (iv) GeM may take an administrative action in terms of the GeM Website Policies against a Buyer which may include reporting of any breach or misconduct to the Buyer Primary User and/or to the competent authority and GeM reserves the right to review the rating of such Buyer, and / or block Buyer's account for such time as considered appropriate by GeM.
  - (v) The Seller and the Buyer understands that the grounds for administrative action as provided under the Contract are only indicative and additional grounds may be provided under the GeM Website Policies including the Incident Management policy. The Seller / Buyer warrants to abide by all additional grounds as may be specified by GeM in the GeM Website Policies from time to time.

## **22. Role of Government E- Marketplace - Gem SPV**

Government e-Marketplace – GeM SPV is the owner of the GeM portal which monitors and supervises all the business transactions on the portal. The role and responsibilities of the company are as under:

- 22.1** To develop, operate and maintain technology driven e-marketplace, through a Managed Service Provider (MSP), to be used by government agencies for procurement of various goods and services in a transparent and efficient manner.
- 22.2** Overall supervision and monitoring of GeM portal operations, policy management, finalization and implementation of various business processes and work flows in adherence with the applicable law and executive orders issued from time to time . To provide tools for on-line Bidding, on-line Reverse Auction and Business Analytics Tools on GeM.
- 22.3** To work continuously for improvements in the Business Processes and Work Flows for various activities / functions on GeM based on feedback from various stakeholders to enhance transparency, efficiency, competitiveness, equality, economy in procurement of goods and services by government agencies.
- 22.4** To finalize General Terms and Conditions for sale and purchase of Goods and Services on GeM, Product / Service Specific Special Terms and Conditions, Special Terms and Conditions for Bunching of Goods / Services, Bid Specific Special Conditions, Project Specific Special Conditions etc.
- 22.5** To finalize, upload and approve Technical Specification Frameworks for various item / service categories on GeM and to monitor conformity of offered products to the larger framework so finalized and uploaded.
- 22.6** To decide addition / deletion of any of the offered product(s)/Product category (ies) and their framework of technical parameters on GeM.
- 22.7** To work and co-ordinate with different Organizations/Departments / Agencies for integration of their Databases with the GeM portal on real time basis for the purpose of verification/authentication of data entries made by stakeholders.

- 22.8 To offer and manage Demand Aggregation services for identified categories across buyers with assured reasonability of price, recommending for placement of orders by individual buyers
- 22.9 To co-ordinate with MSP for conducting workshops for the various Stakeholders in capacity building and in change management associated with the implementation of technology enabled procurement process.
- 22.10 To monitor MSP that the Buyers, Sellers and Service Providers are being assisted properly by them to onboard their goods and services on the GeM platform.
- 22.11 To identify and offer services of 3<sup>rd</sup> parties for Vendor Assessment relating to technical, financial capacity, past experience of sellers including manufacturing / testing facilities / quality control arrangement(s) of manufacturing premises and/or any of the premises related to manufacturing process of products / services offered by the seller / service provider on GeM.
- 22.12 To identify and offer services of 3<sup>rd</sup> parties for testing and certifying the quality of the product offered/ supplied, through documents, test reports/ certificates, testing at any independent lab or through inspection/testing by its authorized representative/s at firm's premises or at user's premises, that buyer choose to use.
- 22.13 Overall monitoring and management of Call Centre/Help desk operations being provided by the MSP.
- 22.14 Removal / debarring the Sellers/Buyers and Goods / services in GeM.
- 22.15 Management of complaints and their redressal mechanism in GeM (not disputes related to concluded contracts).
- 22.16 To identify, integrate and manage MoUs with verifying, certifying and validating entities across government(s) and also professional agencies to reinforce the online paperless, contactless and cashless system on GeM.
- 22.17 To issue Notices, Circulars, News, Flashes, Updates etc in GeM
- 22.18 Reporting and MIS mechanism in GeM
- 22.19 Any other related activities in the GeM
- 22.20 In exceptional circumstances, for ensuring propriety of procurement processes or to obviate possible misuse of GeM functionalities, GeM SPV as GeM Admin may keep any Bidding / RA process on hold for some time as considered appropriate.
- 22.21 To take approved User Charges from Buyers and Sellers for the various transactions on the GeM portal as decided and notified on the GeM portal.

## **23. Miscellaneous Provisions**

- 23.1 Assignment:** Users understand and agree that the GTC, STC and ATC provisions, rights and obligations granted by GeM are non- transferrable or assignable by the User to any third party, without the prior written consent of GeM.

If same is permitted by GeM, all the conditions, rights and obligations of the GTC or any on-going STC/ATC shall also be binding upon such third party assignee besides the User.

**23.2 Indemnification:** The Seller shall at all time indemnify Buyer against all suits and claims which may be made in respect of the goods/services for infringement of any right protected by patent, registration of designs or trade mark. Provided always that in the event of any claim and suit in respect of alleged breach of patent, registered designs or trade-mark being made against the Buyer, the Buyer shall notify the Seller/ Service Provider of the same who shall at its own expense either settle any such dispute or conduct and litigation that may arise there from.

Buyers and Sellers agree to indemnify, defend and hold harmless GeM, its officials, Managed Service Provider (herein after individually and collectively referred to as "indemnified parties") from and against any and all losses, liabilities, claims, suits, proceedings, penalties, interests, damages, demands, costs and expenses (including legal and other statutory fees and disbursements in connection therewith and interest chargeable thereon) asserted against or incurred by the indemnified parties that arise out of, result from, or in connection with

- 23.2.1 Breach of the contract(s); or
- 23.2.2 Any claims made by any third party due to, or arising out of, or in connection with, use of the Website; or
- 23.2.3 Any claim made by any third party regarding content/ information or materials provided by Seller cause any damage to a third party; or arising out of, or in connection with, use of the Website.
- 23.2.4 Violation of any intellectual property rights or any other rights.

Once GeM notifies the Buyer/ Seller of such claims, they shall defend and indemnify GeM for the same. Further, in no case they shall compromise or settle any claim or admit any liability on the part of GeM without the express or prior written consent of GeM which can be withheld or denied or modified by GeM in its sole discretion or as per the Applicable Laws.

**23.3 Severability:** If due to any change in Applicable laws, certain part of the GTC or any applicable STC or any provisions of the GeM policies or portions thereof, becomes unenforceable, the remaining provisions shall continue in full force and effect so as to give effect to the intent of the parties.

**23.4 Website Terms and Policies Updation:** Buyers and Sellers are advised to check the website terms and conditions as well as policies such as Privacy Policy and the Website Disclaimer at all times, as GeM may update the Website and such terms from time to time.

### 23.5 List of Prohibitive Activities (Suggestive And Non-Exhaustive):

**LIST OF PROHIBITIVE ACTIVITIES:** The following is an indicative list of prohibitive activities which the Buyers and the Sellers registered on GeM platform shall not perform on the GeM platform. A breach of any of the prohibited activities shall give the right to GeM under the Applicable Laws or in terms of these GTC or the GeM Website Policies to take administrative action which may include partial or permanent disabling of account on GeM Website, debarment etc. Additionally, GeM may remove any non-compliant information and reserves the right to preserve and share with the appropriate authority such information and associated records for investigation purposes. The Buyer and the Seller understand that this list is only indicative and additional activities may be prohibited under the GeM Website Policies. The Buyers and the Sellers shall undertake to provide their full support that may be required by GeM for removal and disabling of the non compliant information. The prohibited activities include:

- (i) Indulging in cyber crime or other criminal activities which can become a threat to GeM, GeM Website, to the Government of India or to any State Government or Government Agency.
- (ii) Advertising, exhibiting, representing, publishing, pronouncing, listing, delivering, offering to sell or selling any kind of Goods/Services which can cause any kind of infringement or disparagement of intellectual property rights.
- (iii) Selling refurbished, counterfeit and/or fake Goods / Services under a brand or misusing others brand name.
- (iv) Offering to sell or selling above the MRP any Goods or misrepresenting the MRP.
- (v) Delivering some other Goods or Services instead of the Goods or Services Contracted for or delivering empty parcels or used Goods in breach of the terms of the Contract.
- (vi) Offering to sell or selling freebies which are 'Not for sale' Goods.
- (vii) Listing of the Goods on GeM Website without authorization to sell Goods manufactured by the OEM in open market or without proper authorisation, if any required, for providing the Service.
- (viii) Listing of the Goods or Services is done on GeM Website without guarantee/warranty or without a genuine guarantee/warranty.
- (ix) Listing of the Goods or Services in irrelevant or inappropriate categories or with vague or conflicting specifications or description (including descriptive or pictorial description).

- (x) The Buyer /Seller registering on GeM and/or offering or buying the Goods and/or Services and/or participating in e-bidding/reverse auction on GeM, without the requisite authorization to enter into contract on behalf of the concerned legal entity. Failing which such individual(s) shall be individually liable for its actions and also for any liability arising out of such actions.
- (xi) If any Seller has been debarred from GeM then such Seller or their authorized sellers shall also not be permitted to register and offer/sell their products on GeM and / or participate in Bids / RA on GeM.
- (xii) Using GeM prices for making procurement outside GeM Portal.
- (xiii) Splitting of demands by creating multiple Bids/RAs of same goods / services or making repeated procurements of same goods/services through Direct Purchase / L-1 buying as per rule 149(i) and 9(ii) of GFR- 2017.
- (xiv) Uploading goods / services containing information that —
  - (a) belongs to another person and to which the user does not have any right to;
  - (b) is grossly harmful, harassing, blasphemous, defamatory, obscene, pornographic, paedophilic, libellous, invasive of another's privacy, hateful, or racially, ethnically objectionable, disparaging, relating or encouraging money laundering or gambling, or otherwise unlawful in any manner whatever;
  - (c) harm minors in any way;
  - (d) infringes any patent, trademark, copyright or other proprietary rights;
  - (e) violates any law for the time being in force;
  - (f) deceives or misleads the addressee about the origin of such messages or communicates any information which is grossly offensive or menacing in nature;
  - (g) impersonate another person;
  - (h) contains software viruses or any other computer code, files or programs designed to interrupt, destroy or limit the functionality of any computer resource;
- (xv) threatens the unity, integrity, defence, security or sovereignty of India, friendly relations with foreign states, or public order or causes incitement to the commission of any cognizable offence or prevents investigation of any offence or is insulting any other nation.
- (xvi) Achieving or trying to achieve illegal access to features on GeM Website not specifically authorised or exceeding the scope of authorized access to or other features of the GeM Website;

- (xvii) Obstructing or causing GeM to lose (in whole or in part) the services provided by any internet service provider ("ISPs") or carrying out any cyber security incident;
- (xviii) Sending unsolicited emails, bulk messaging, auto messaging, junk email, spam and like.

**24. Incident management Policy on GeM:** GeM is a trust based system and self-declaration is the key, along with a strong automated process to penalize any deviant behaviour on part of Sellers / Buyers. For this purpose, deviations from the terms and conditions of procurement on GeM, including general terms and conditions, special and additional terms and conditions and any other relevant Government rules and guidelines, are termed as "deviation". A deviation can occur while listing the products on GeM, at pre-contract stage, during bidding or at post contract stage on GeM. The mechanism for reporting and initiating action on such deviation has been detailed in the Incident Management Policy available on GeM portal under Resources. All stake holders of GeM shall be bound by the actions as detailed in the Incident Management Policy.

All administrative actions under this Incident management Policy, taken by GeM against any of the stakeholders shall not cause any limitation on the legal and/or contractual remedies including any financial recoveries, available to Buyers/Sellers under the Terms and Conditions of contract and/or GeM policies. In case the Buyer / Seller choose to pursue any of these remedies, GeM shall not be made party to such proceedings / remedial actions taken by Buyer/Seller under the contractual provisions.

**25. Use of Aadhaar Number in GeM:** Purpose of the Aadhaar authentication in GeM is to identify the user using eKYC. GeM has provisioned the option for Sellers and Buyers to provide virtual Aadhaar ID instead Aadhaar number. GeM receives First Name, Last Name, Mobile Number, Email ID, DOB and Gender details. It is used to link the mobile number with the user who is registering on GeM; on which subsequently OTP is sent for achieving the property of non-repudiation in different artefacts / documents generated on GeM. GeM has provisioned an alternative Identity Information option through PAN based verification to Sellers.

**26. Compliance of Restrictions under Rule 144 (xi) of GFR 2017:** Restrictions on procurement from a bidder of a country which shares a land border with India

- I. Any bidder from a country which shares a land border with India will be eligible to bid in this tender only if the bidder is registered with the Competent Authority.
- II. "Bidder" (Seller / Service Provider) means any person or firm or company, including any member of a consortium or joint venture (that is an association of several persons, or firms or companies), every artificial juridical person not falling in any of the descriptions of bidders stated hereinbefore, including any agency branch or office controlled by such person, participating in a procurement process.
- III. "Bidder from a country which shares a land border with India" for the purpose of this Order means: -

- a. An entity incorporated, established, or registered in such a country; or
- b. A subsidiary of an entity incorporated, established, or registered in such a country; or
- c. An entity substantially controlled through entities incorporated, established, or registered in such a country; or
- d. An entity whose beneficial owner is situated in such a country; or
- e. An Indian (or other) agent of such an entity; or
- f. A natural person who is a citizen of such a country; or
- g. A consortium or joint venture where any member of the consortium or joint venture falls under any of the above

IV. The beneficial owner for the purpose of (iii) above will be as under:

1. In case of a company or Limited Liability Partnership, the beneficial owner is the natural person(s), who, whether acting alone or together, or through one or more juridical person, has a controlling ownership interest or who exercises control through other means. Explanation—
  - a. "Controlling ownership interest" means ownership of or entitlement to more than twenty-five per cent. of shares or capital or profits of the company;
  - b. "Control" shall include the right to appoint majority of the directors or to control the management or policy decisions including by virtue of their shareholding or management rights or shareholders agreements or voting agreements;
2. In case of a partnership firm, the beneficial owner is the natural person(s) who, whether acting alone or together, or through one or more juridical person, has ownership of entitlement to more than fifteen percent of capital or profits of the partnership;
3. In case of an unincorporated association or body of individuals, the beneficial owner is the natural person(s), who, whether acting alone or together, or through one or more juridical person, has ownership of
 

or

entitlement to more than fifteen percent of the property or capital or profits of such association or body of individuals;
4. Where no natural person is identified under (1) or (2) or (3) above, the beneficial owner is the relevant natural person who holds the position of senior managing official;
5. In case of a trust, the identification of beneficial owner(s) shall include identification of the author of the trust, the trustee, the beneficiaries with fifteen percent or more interest in the trust and any other natural person exercising ultimate effective control over the trust through a chain of control

or ownership.

- V. An Agent is a person employed to do any act for another, or to represent another in dealings with third person.
- VI. The successful bidder shall not be allowed to sub-contract works to any contractor from a country which shares a land border with India unless such contractor is registered with the Competent Authority.

Any false declaration and non-compliance of the above would be a ground for immediate termination of the contract and further legal action in accordance with the laws.

**Clause 27: Caution Money Deposit:**

(i) All sellers on GeM are required to deposit a one-time amount as under as caution money:

- a) Seller Turnover less than 1 Crore: Rs 5,000/-
- b) Seller Turn over > 1 Crore but < 10 Crore: Rs 10,000/-
- c) Seller Turn over > 10 Crore: Rs 25,000/-

(ii) The above caution money shall remain at the disposal of GeM SPV. This can be forfeited in part or in full (as per approval of CEO (GeM)) in following circumstances:

- a) Seller rejects or does not accept any Direct Purchase / L-1 Purchase order within defined timelines leading to order auto cancellation.
- b) Failure of the seller in executing any GeM contract or if the Seller fails or neglects to observe or perform any of his obligations under the contract (applicable only in respect of contracts that did not have provision of Performance Security / PBG).
- c) Withdraws any bid submitted on GeM within the period of validity of the bid.
- d) Fails to furnish requisite performance security / PBG as per GeM e-bid / RA conditions.

(iii) In case the Caution Money of any seller is forfeited in full or part and his caution money deposit goes below the threshold indicated in para 1 above, the seller account shall be put on hold till the seller re-coups the caution Money account to required value. Seller's stock will become zero for all categories and seller will not be allowed to update anything till the caution money is topped up to minimum required amount.

(iv) Forfeiture of caution money as per above shall be over and above any other actions taken against such sellers as per GeM Incident Management Policy and shall be without any prejudice to the rights and remedies available to GeM and / or Buyer as per provisions of the relevant contracts.

**Clause 28: CMS 3.0 and OEM - Reseller responsibility matrix:**

GeM has implemented enhanced Catalogue Management System (CMS 3.0) on GeM Portal. The Primary Objective of CMS 3.0 is to offer higher level of ownership & accountability to OEMs & its approved Resellers while maintaining Efficiency, Transparency & Inclusiveness of GeM. Complete and detailed Obligations and Privileges matrix of the different stakeholders in different quadrants is given in CMS document available on GeM Portal and OEMs and Resellers are bound to operate on GeM in compliance with the CMS document as updated from time to time.

1) CMS Quadrant 1 (CMS Q1): Product offers in categories under Q1 will be solely offered by GeM validated OEMs. OEM shall be exclusively responsible for maintaining currency and sanity of catalogue and its offer in the Market Place. OEM shall be absolutely and exclusively responsible and be legally liable for sanity and quality of offers including Warranty and After Sales Service obligations.

2) CMS Quadrant 2 (CMS Q2): OEMs as well as pre-Authorized Resellers can offer products in Q2. OEMs shall operate Market Place subject to providing its complete list of Open market authorized sellers along with formal commitment to list and maintain all appropriate and current Product Catalogue for pairing by its Resellers. OEM shall be absolutely and exclusively responsible and be legally liable for sanity and quality of catalogues including Warranty and After Sales Service obligations. Authorized Resellers shall be responsible for Pairing their offer with the already existing Product Catalogue created by the OEM. However, resellers can Update their Offer Price, Stock and Delivery Locations solely at their own discretion and shall be solely responsible for the same.

3) CMS Quadrant 3 (CMS Q3): Catalogue creation in categories under Q3 can be from OEMs and/or their Authorized Resellers concurrently. In case OEM has not created Product Catalogue, Authorized Resellers of OEMs are also permitted to do the same. However, OEM (when registered on GeM and taken OEM Dashboard) shall be responsible for Validating & verifying the Catalogue uploaded by Reseller, Maintaining the Catalogue by adding/updating the Specifications, MRP etc. specific to catalogue. OEM shall also assume all responsibility and legal liability for sanity and quality of offers including Warranty and After Sales Service obligations. However, resellers can Update their Offer Price, Stock and Delivery Locations solely at their own discretion and shall be solely responsible for the same.

4) CMS Quadrant 4 (CMS Q4): Catalogue creation in categories under Q4 can be done by OEMs as well as by any Reseller also. However, OEM (when registered on GeM and taken OEM Dashboard) shall be responsible for Validating & verifying the Catalogue uploaded by Reseller, Maintaining the Catalogue by adding/updating the Specifications, MRP etc. specific to catalogue. However, there is no requirement of any endorsement or authorization of the reseller by the OEM. Resellers can Update their Offer Price, Stock and Delivery Locations solely at their own discretion and shall be solely responsible for the same. Reseller will also be responsible for providing Replacement Warranty in case of Q4 products and Buyer shall not be required to take up with OEM for any warranty claims.

5) CMS (Special Category) : The Special Category is a specialized segment outside the four quadrants for select few categories that require a customized behavior such as Self-Help Groups (SHG) categories.

In Q3 and Q4, in case of re-sellers, if the reseller has not been approved as an authorized re-seller by the OEM on GeM, the re-seller is required to give an undertaking as under while uploading the product, while accepting any order and while participating in any bid:

“I hereby undertake that I have made arrangements for getting the stores from authorized distributor / dealer / channel partner of the OEM of the offered product. At the time of delivery of goods, I will provide necessary chain documents to prove that the supplied goods are genuine and are being sourced from authorized distributor / dealer / channel partner of the OEM. In case of any complaint from the Buyer / Consignee about genuineness of the supplied products, I shall be responsible for providing genuine replacement supplies.”

By uploading any product on GeM or accepting any order on GeM or by participating in any bid on GeM, the re-seller is deemed to have given above undertaking and is liable for compliance of the same.

Further in view of the on-line verification of Seller credentials by the OEM on GeM platform, there is no need for Buyer to ask for or insist on furnishing of OEM authorization in bids in respect of “OEM verified Catalogue” offered by "OEM Verified Reseller". OEM authorization is also not required to be sought and checked by Buyers in case of bids for products in Q1 or Q2.

#### **Clause 29: One Bid per Bidder**

A Bidder shall submit only one bid in a particular bidding process (unless otherwise allowed in the bid STC / ATC conditions). In case of a holding company having more than one independent manufacturing units or more than one unit having common business ownership / management, only one unit should quote. Similar restrictions shall apply to closely related sister companies. Bidder's sister/ Associated/ Allied concern(s) participating or applying against the same tender, shall lead to disqualification of Bidders. Sister/ Associated/ Allied concern means a company, society, partnership firm or proprietorship firm having one or more common persons as Director/ Partner/ Member/ Owner. A Bidder who submits more than one bid will cause all the proposals submitted in the particular bid to be disqualified. In relation to the above, a person will include firm(s) of Proprietorship / Partnership Firm / Limited Liability Partnership / Private Limited / Limited company / Society registered under Society's Act / Statutory Bodies / any other legal entity, as the case maybe, & will be deemed to have submitted multiple bids in a particular bid if a person bids in any of the two formats given below:

- a) individual or proprietorship format and/or
- b) a partnership or association of persons format and/or
- c) a company format

Whereby,

- A company shall for this purpose include any artificial person whether constituted under the Indian laws or of any other country.
- A person shall be deemed to have bid in a partnership format or in association of persons format if he is a partner of the firm which has submitted the bid or is a member of any association of persons which has submitted a bid.
- A person shall be deemed to have bid in a company format if the person holds:
  - a) more than 10% (ten percent) of the voting share capital of the company which has submitted a bid, or
  - b) is a director and / or Key Managerial Personnel of the company which has submitted a bid, or
  - c) holds more than 10% (ten percent) of voting share capital in and/or is a director and / or Key Managerial Personnel of a holding company of that company which has submitted the bid.

By making a bid pursuant to the Tender Documents, the bidder / tenderer shall be deemed to have declared that the bidder / tenderer has not made any other bid or multiple bids as understood or deemed in terms of this clause.

All the bids of a bidder who has submitted multiple bids, as per the clause, shall be rejected and Earnest Money Deposit for all such bids shall be forfeited, not by way of penalty or liquidated damages but by way of reimbursement of the pre-estimated costs likely to be incurred by the buyer towards bidding process and in the scrutiny & evaluation of bids.

In addition to the above, bidders found to be in contravention to the said clause will be liable for administrative actions.

\*\*\*\*\* **END OF DOCUMENT** \*\*\*\*\*

**ANNEXURE-A**  
**BID SPECIFIC ADDITIONAL TERMS & CONDITIONS FOR THE**  
**PROCUREMENT OF CS SEAMLESS PIPES FOR IOCL BARAUNI & PANIPAT PROJECTS**

| SI No | BHEL requirement  | Agree / Disagree |
|-------|---|------------------|
| 1     | <p><b>SCOPE OF SUPPLY-</b></p> <p>i) Supply of Seamless CS pipes as per Technical requirements mentioned in</p> <p style="margin-left: 20px;">a. Engineering drawings, Special contract conditions 7471:SCC:001 Rev 00 dt 22.02.2022, QP Ref 7471:QPC:01 Rev 04 dt 13.10.2021 for Barauni Project.</p> <p style="margin-left: 20px;">b. Engineering drawings, TDG Ref 7470:TDG:001 Rev 00 dt 21.02.2022 &amp; QP Ref 7470:QPC:01 Rev 03 dt 15.11.2021 for Panipat Project.</p> <p>ii) To be delivered at Respective project sites.</p> <p>iii) List of items shall be as per Unpriced bid enclosed (<b>Annexure-C</b>).</p>   |                  |
| 2     | <p><b>A. TECHNICAL REQUIREMENT-</b></p> <p>i) Supply of Seamless CS pipes as per Technical requirements mentioned in</p> <p style="margin-left: 20px;">a. Engineering drawings, Special contract conditions 7471:SCC:001 Rev 00 dt 22.02.2022, QP Ref 7471:QPC:01 Rev 04 dt 13.10.2021 for Barauni Project.</p> <p style="margin-left: 20px;">b. Engineering drawings, TDG Ref 7470:TDG:001 Rev 00 dt 21.02.2022 &amp; QP Ref 7470:QPC:01 Rev 03 dt 15.11.2021 for Panipat Project.</p> <p>Length of supply &amp; Edge preparation shall be as per Engineering drawing mentioned in the Unpriced bid (<b>Annexure-C</b>). CS Seamless Pipes to specifications ASTM A106GrB &amp; ASME SA106GrB, ASTM A333Gr6 &amp; ASME SA333Gr6 are technically acceptable.</p> <p>ii) Submit duly filled in Unpriced bid enclosed (<b>Annexure-C</b>).</p> <p>iii) Submit duly filled in Checklist enclosed along with supporting documents (<b>Annexure-D</b>).</p> <p>iv) Submit duly filled in Pre-Qualification Criteria along with supporting documents (<b>Annexure-G</b>).</p> <p><b>Deviation if any shall be clearly indicated in a separate sheet. UNDISCLOSED DEVIATIONS ARE NOT ACCEPTABLE.</b></p> <p><b>B. CUSTOMER APPROVED MANUFACTURER-</b></p> <p>1. Bids from Approved Indian MAKES / Manufacturers as per <b>Annexure-B</b> are acceptable for the respective projects.</p> <p>2. Bids from Stockists as per <b>Annexure-B</b> with make as per <b>Annexure-B</b> are acceptable for the respective projects.</p> <p>3. Bids of other Stockists and Traders are also acceptable subject to Supply of Make as per Approved Manufacturers List (<b>Annexure-B</b>) and acceptance of their bid by BHEL's Customer.</p> <ul style="list-style-type: none"> <li>➤ Bids qualifying the PQR conditions shall be evaluated for techno-commercial soundness.</li> <li>➤ Techno-Commercially qualified bidders not available in the Customer approved vendor list will be taken up for Customer approval.</li> <li>➤ Credentials for Customer approval shall be submitted, if required. Additional documents will be sought from the bidders, if necessary.</li> <li>➤ Holiday list of Customer shall be reviewed as on date of completion of techno-commercial evaluation.</li> <li>➤ Price evaluation of only such Techno-Commercially qualified bidders not available in Holiday list of Customer will be considered for further tender processing.</li> </ul> <p><b><u>Points related to Customer approval are applicable for IOCL Panipat project only.</u></b></p> |                  |
| 3     | <p><b>VALIDITY OF OFFER-</b></p> <p>The quotation shall be valid at least for a period of <b>90 days from the date of technical bid opening / 60 days from the date of price evaluation</b> whichever is later. Offer with lesser validity may not be considered.</p>   |                  |
| 4     | <p><b>DELIVERY PERIOD-</b></p> <p><b>Delivery is the essence of the contract. Bids deviating from the delivery requirement shall be rejected.</b></p> <p><b>60 days</b> from the date of Purchase order / LOI</p>   |                  |

**ANNEXURE-A**

**BID SPECIFIC ADDITIONAL TERMS & CONDITIONS FOR THE  
PROCUREMENT OF CS SEAMLESS PIPES FOR IOCL BARAUNI & PANIPAT PROJECTS**

|   |  |  |
|---|--|--|
| 5 | <p><b>LIQUIDATED DAMAGES-</b><br/>If the bidder fails to deliver the item within the period specified in the contract the purchaser shall deduct Liquidated Damages, a sum equivalent to 0.5% of the price for each week of delay up to a maximum of 10% of the price of delayed/undelivered portion.</p> <p><b>LD will be reckoned from the date of Lorry way bill / Invoice / E-way bill whichever is later.</b></p>   |  |
| 6 | <p><b>DELIVERY TERM-</b><br/>Schedule 1 - 'FOR' Barauni Project Site (all incl of P&amp;F, F&amp;I, testing, inspection charges etc)<br/>Schedule 2 - 'FOR' Panipat Project Site (all incl of P&amp;F, F&amp;I, testing, inspection charges etc)</p>   |  |
| 7 | <p><b>EVALUATION &amp; ORDERING-</b></p> <ol style="list-style-type: none"><li>1. Only Techno-commercially qualified bidders shall be considered for price evaluation. Price evaluation shall be through <b>Reverse auction</b> in GeM portal with <b>H1-Highest Priced Bid Elimination</b>.</li><li>2. Evaluation of bids and ranking of bidders shall be done on package basis. Bidder shall quote for all items of a package mandatorily.</li><li>3. Quoted rates shall be <b>inclusive of GST</b>.</li><li>4. Minimum Order Quantity (MOQ) / Minimum Order Value (MOV) condition will not be accepted. Bids of such suppliers (if any) insisting for MOQ / MOV will be rejected.</li></ol> <p><b>THIS IS A FIXED PRICE CONTRACT AND PRICES ARE FIRM TROUGHOUT THE EXECUTION OF THE CONTRACT.</b></p>   |  |
| 8 | <p><b>PREFERENCE TO MAKE IN INDIA PRODUCTS (FOR BIDS &lt; 200 CRORE)-</b><br/>Preference shall be given to Class 1 local supplier as defined in public procurement (Preference to Make in India), Order 2017 as amended from time to time and its subsequent Orders/Notifications issued by concerned Nodal Ministry for specific Goods/Products. The minimum local content to qualify as a Class 1 local supplier is denote in the bid document. If the bidder (manufacturer) wants to avail the Purchase preference, the bidder must upload a certificate (<b>as per Annexure-E</b>) regarding the percentage of the local content and the details of locations at which the local value addition is made along with their bid, failing which no purchase preference shall be granted. In case the bid value is more than Rs 10 Crore, the declaration relating to percentage of local content shall be certified by the statutory auditor or cost auditor, if the OEM is a company and by a practicing cost accountant or a chartered accountant for OEMs other than companies as per the Public Procurement (preference to Make-in -India) order 2017 dated 04.06.2020.</p> <p>Only <b>Class-I and Class-II Local suppliers</b> as per MII order dated 4.6.2020 <b>will be eligible to bid</b>. Non - Local suppliers as per MII order dated 04.06.2020 are not eligible to participate. However, eligible micro and small enterprises will be allowed to participate. In case Buyer has selected Purchase preference to Micro and Small Enterprises clause in the bid, the same will get precedence over this clause.</p> |  |
| 9 | <p><b>PURCHASE PREFERENCE TO MICRO AND SMALL ENTERPRISES (MSES)-</b><br/>Purchase preference will be given to MSEs as defined in Public Procurement Policy for Micro and Small Enterprises (MSEs) Order, 2012 dated 23.03.2012 issued by Ministry of Micro, Small and Medium Enterprises and its subsequent Orders / Notifications issued by concerned Ministry. If the bidder wants to avail the Purchase preference, the bidder must be the manufacturer of the offered product in case of bid for supply of goods. Traders are excluded from the purview of Public Procurement Policy for Micro and Small Enterprises. <b>Udyam Registration certification shall be submitted.</b></p> <p>If L-1 is not an MSE and MSE Seller (s) has/have quoted price within L-1+ 15% (Selected by Buyer) of margin of purchase preference / price band defined in relevant policy, such Seller shall be given opportunity to match L-1 price and contract will be awarded for 25% (selected by Buyer) percentage of total QUANTITY.</p>  |  |

**ANNEXURE-A**

**BID SPECIFIC ADDITIONAL TERMS & CONDITIONS FOR THE  
PROCUREMENT OF CS SEAMLESS PIPES FOR IOCL BARAUNI & PANIPAT PROJECTS**

|    |  |  |
|----|--|--|
| 10 | <p><b>GUARANTEE-</b><br/>The materials are to be guaranteed for satisfactory performance for a period of 24 months from the date of dispatch or 18 months from the date of commissioning / putting into use whichever is earlier. Pipe suppliers shall guarantee for the coating on the pipes also.</p> <p>Any defect noticed during the above period, the same shall be rectified / replaced free of cost on FOR destination basis within a reasonable time, maximum limited to the agreed delivery period, to the satisfaction of BHEL and the End User.</p> <p>To this effect a guarantee certificate should be sent along with the dispatch documents in the event of an order. No deviation in this regard shall be accepted.</p>   |  |
| 11 | <p><b>INSPECTION-</b><br/>Inspection will be done by <b>BHEL / BHEL Authorized TPI agency &amp; Customer / Customer Authorized TPI agency (if required)</b>. Inspection charges of BHEL / Their representative are to BHEL A/c. Any other testing charges should be included in the quoted prices.</p> <p>Inspection requirements and documents / certification shall be as per QP Ref 7471:QPC:01 Rev 04 dt 13.10.2021 for Barauni Project &amp; QP Ref 7470:QPC:01 Rev 03 dt 15.11.2021 for Panipat Project.</p> <ul style="list-style-type: none"><li>➤ All facilities, equipment and instruments required for inspection shall be provided by the contractor free of cost. BHEL's Representatives will have free access to contractor's works during the currency of the contract.</li><li>➤ BHEL shall have general supervision and direction over the work. BHEL has the authority to stop the work, whenever such stoppage may be necessary to ensure the proper execution of the contract. BHEL shall also have the authority to reject all the work which does not conform to the specification.</li></ul> <p>BHEL if required may test the finished sample per lot/size at NABL approved Lab at the bidder's cost.</p>   |  |
| 12 | <p><b><u>QUALITY DOCUMENTS</u></b><br/>One original + two copies of Quality Documents, as called for in the Inspection test plan/Purchase order shall be sent to Purchase / Piping centre BHEL Chennai immediately after the shipment / despatch of Items.<br/>All the quality documents are to be submitted in soft copy (in CD format) apart from the hard copy.</p>   |  |
| 13 | <p><b><u>TERMS OF PAYMENT:</u></b> Payment terms shall be as per Clause "Payment Timelines" of the GeM bid, i.e., 100% payment within 90 days of issue of CRAC.<br/>However, preference in payment shall be given as following:</p> <ul style="list-style-type: none"><li>a. 100% payment <b>within 60 days</b> of issue of CRAC for <b>Medium category bidders</b> subject to submission of relevant documents.</li><li>b. 100% payment <b>within 45 days</b> of issue of CRAC for <b>MSE (Micro and small) bidders</b> subject to submission of relevant documents.</li></ul> <p><b><u>No other payment terms will be accepted. If bidders propose for any other payment term other than indicated above, such bids will be rejected.</u></b></p> <p><b><u>PAYMENT DOCUMENTS -</u></b><br/>Payment shall be made against presentation of following documents to Finance Department by Purchase department:</p> <ul style="list-style-type: none"><li>a) Tax Invoice in triplicate</li><li>b) Delivery Challan in triplicate whichever is applicable</li><li>c) Guarantee certificate</li><li>d) Lorry Way Bill &amp; E-way bill (Original + Two copies)</li><li>e) Copy of Site Acknowledged LR</li><li>f) CRAC (Consignee Receipt &amp; Acceptance Certificate) in GeM</li><li>g) Quality documents (as per approved QP/PO)</li></ul> <p>Hence,</p> <ul style="list-style-type: none"><li>1. Soft copy of Invoice and LR should be sent immediately after dispatch by e-mail to Purchase.</li><li>2. Hard copy should be sent subsequently within 1 week.</li></ul> <p><b>Payment shall be processed only after receipt of CRAC in GeM.</b></p> |  |

**ANNEXURE-A**

**BID SPECIFIC ADDITIONAL TERMS & CONDITIONS FOR THE  
PROCUREMENT OF CS SEAMLESS PIPES FOR IOCL BARAUNI & PANIPAT PROJECTS**

|    |   |  |
|----|---|--|
|    |   |  |
| 14 | <p><b><u>CANCELLATION / TERMINATION OF CONTRACT, DEFAULT / BREACH OF CONTRACT AND RISK PURCHASE:</u></b></p> <p>In case of abnormal delays (beyond the maximum late delivery period as per Penalty clause) in supplies / defective supplies or non-fulfilment of any other terms and conditions given in Purchase Order as enumerated subsequently in this clause, Purchaser shall be entitled to cancel the Order / Contract either in whole or portion thereof without compensation to Seller / Contractor and if the Purchaser so desires, may procure upon such terms and in such manner as deemed appropriate, stores not so delivered or others of similar description where stores exactly complying with particulars are not, in the opinion of the Purchaser, which shall be final, readily procurable, at the risk and cost of the Seller / Contractor and the Seller / Contractor shall be liable to the Purchaser for any excess costs provided that the Seller / Contractor shall continue the performance of the Order / Contract to the extent not cancelled under the provisions of this clause. The Seller / Contractor shall on no account be entitled to any gain on such repurchases. If bidder does not agree to the above Risk Purchase Clause, BHEL reserves the right to reject the offer.</p> <p>Risk &amp; Cost Clause, in line with Conditions of Contract may be invoked in any of the following cases:</p> <ul style="list-style-type: none"><li>i. Contractor / supplier's poor progress of the work vis-à-vis execution timeline as stipulated in the Contract, backlog attributable to contractor/ supplier including unexecuted portion of work / supply does not appear to be executable within balance available period (#) considering its performance of execution.</li><li>ii. Withdrawal from or abandonment of the work by contractor before completion of the work as per contract.</li><li>iii. Non completion of work / Non-supply by the Contractor / supplier within scheduled completion / delivery period as per Contract or as extended from time to time, for the reasons attributable to the contractor / supplier.</li><li>iv. Termination of Contract on account of any other reason (s) attributable to Contractor / Supplier.</li><li>v. Assignment, transfer, subletting of Contract without BHEL's written permission resulting in termination of Contract or part thereof by BHEL.</li><li>vi. Non-compliance to any contractual condition or any other default attributable to Contractor / Supplier.</li></ul> <p>Risk and Cost amount against Balance Work:<br/>Risk &amp; Cost Amount= [(A-B) + (A x H/100)]<br/>Where,<br/>A= Value of Balance scope of Work / Supply (*) as per rates of new contract<br/>B= Value of Balance scope of Work / Supply (*) as per rates of old contract being paid to the contractor / supplier at the time of termination of contract i.e. inclusive of PVC &amp; ORC, if any.<br/>H= Overhead Factor to be taken as 5</p> <p>In case (A-B) is less than 0 (zero), value of (A-B) shall be taken as 0 (zero).</p> <p>*(Balance scope of work / supply)</p> <p>Difference of Contract Quantities and Executed Quantities as on the date of issue of Letter for 'Termination of Contract', shall be taken as balance scope of Work / Supply for calculating risk &amp; cost amount.</p> <p>Contract quantities are the quantities as per original contract. If, Contract has been amended, quantities as per amended Contract shall be considered as Contract Quantities.</p> |  |

**ANNEXURE-A**

**BID SPECIFIC ADDITIONAL TERMS & CONDITIONS FOR THE  
PROCUREMENT OF CS SEAMLESS PIPES FOR IOCL BARAUNI & PANIPAT PROJECTS**

|    |  |  |
|----|--|--|
|    | <p>Items for which total quantities to be executed have exceeded the Contract Quantities based on drawings issued to contractor from time to time till issue of Termination letter, then for these items total Quantities as per issued drawings would be deemed to be contract quantities.</p> <p>Substitute / extra items whose rates have already been approved would form part of contract quantities for this purpose. Substitute / extra items which have been executed but rates have not been approved, would also form part of contract quantities for this purpose and rates of such items shall be determined in line with contractual provisions.</p> <p>However, increase in quantities on account of additional scope in new tender shall not be considered for this purpose. Note: In case portion of work is being withdrawn, contract quantities pertaining to portion of work withdrawn shall be considered as 'Balance scope of work / supply' for calculating Risk &amp; Cost amount.</p> <p><b><u>LD against delay in executed work / supply in case of Termination of Contract in case of Risk and Cost Option</u></b><br/>LD against delay in executed work / supply shall be calculated in line with LD clause of the contract for the delay attributable to contractor / supplier. For limiting maximum LD value, contract value shall be taken as Executed Value of work / supply.</p> <p>Method for calculation of "LD against delay in executed work / supply" is given below.</p> <p>i. Let the time period from scheduled date of start of work till termination of contract excluding the period of Hold (if any) not attributable to contractor / supplier= T1</p> <p>ii. Let the value of executed work / supply till the time of termination of contract= X</p> <p>iii. Let the Total Executable Value of work / supply for which inputs / fronts were made available to contractor / supplier and were planned for execution till termination of contract= Y</p> <p>iv. Delay in executed work / supply attributable to contractor/supplier i.e. T2= (1- X/Y) * T1</p> <p>v. LD shall be calculated in line with LD clause of the Contract for the delay attributable to contractor / supplier taking "X" as Contract Value and "T2" as delay attributable to contractor / supplier.</p> <p>Note: In case portion of work / supply is withdrawn, no LD shall be applicable for portion of work / supply withdrawn.</p> <p>Recovery from Supplier<br/>Recoveries from contractor / supplier on whom risk &amp; cost has been invoked shall be made from the following:</p> <p>i. Dues available in the form of Bills payable to contractor / supplier, SD, BG's against the same contract.</p> <p>ii. Dues payable to contractor / supplier against other contracts in the same Region / Unit / Division of BHEL.</p> <p>iii. Dues payable to contractor / supplier against other contracts in the different Region / Unit / division of BHEL.</p> <p>Legal Options for recovery of dues payable by the supplier / contractor.</p> <p><b>Bids deviating from the above BHEL's standard condition will be rejected.</b></p> |  |
| 15 | <p><b><u>NON-DISCLOSURE AGREEMENT (NDA):</u></b><br/>The bidders shall enter into the Non-disclosure agreement totally voluntarily, with full knowledge of its meaning and without duress. <b>(Format attached – as per Annexure-F).</b></p>   |  |
| 16 | <p><b><u>FRAUD PREVENTION POLICY:</u></b><br/>The Bidder along with its associate/ collaborators/ sub-contractors/ sub-Bidders/ consultants/ service providers shall strictly adhere to BHEL Fraud Prevention Policy displayed on BHEL website <a href="http://www.bhel.com">http://www.bhel.com</a> and shall immediately bring to the notice of BHEL Management about any fraud or suspected fraud as soon as it comes to their notice.</p>  |  |

**ANNEXURE-A**

**BID SPECIFIC ADDITIONAL TERMS & CONDITIONS FOR THE  
PROCUREMENT OF CS SEAMLESS PIPES FOR IOCL BARAUNI & PANIPAT PROJECTS**

|    |  |  |
|----|--|--|
| 17 | <p><b><u>SUSPENSION OF BUSINESS DEALINGS WITH SUPPLIERS / CONTRACTORS:</u></b></p> <p>The offers of the bidders who are under suspension as also the offers of the bidders, who engage the services of the banned firms /principal/agents, shall be rejected. The list of banned firms is available on BHEL web site <a href="http://www.bhel.com">www.bhel.com</a>.</p> <p><b>Integrity commitment, performance of the contract and punitive action thereof:</b></p> <p><b>Commitment by BHEL</b></p> <p>BHEL commits to take all measures necessary to prevent corruption in connection with the tender process and execution of the contract. BHEL will during the tender process treat all Bidder(s) in a transparent and fair manner, and with equity.</p> <p><b>Commitment by Bidder/ Supplier/ Contractor</b></p> <ul style="list-style-type: none"><li>• The bidder/ supplier/ contractor commit to take all measures to prevent corruption and will not directly or indirectly influence any decision or benefit which he is not legally entitled to nor will act or omit in any manner which tantamount to an offence punishable under any provision of the Indian Penal Code, 1860 or any other law in force in India.</li><li>• The bidder/ supplier/ contractor will, when presenting his bid, disclose any and all payments he has made, and is committed to or intends to make to agents, brokers or any other intermediaries in connection with the award of the contract and shall adhere to relevant guidelines issued from time to time by Govt. of India/ BHEL.</li><li>• The bidder/ supplier/ contractor will perform/ execute the contract as per the contract terms &amp; conditions and will not default without any reasonable cause, which causes loss of business/ money/ reputation, to BHEL.</li></ul> <p>If any bidder/ supplier/ contractor during pre-tendering/ tendering/ post tendering/ award/ execution/ post execution stage indulges in any act, including but not limited to, mal-practices, cheating, bribery, fraud or and other misconduct or formation of cartel so as to influence the bidding process or influence the price or tampers the tendering process or acts or omits in any manner which tantamount to an offence punishable under any provision of the Indian Penal Code, 1860 or any other law in force in India, then, action may be taken against such bidder/ supplier/ contractor as per extant guidelines of the company available on <a href="http://www.bhel.com">www. bhel.com</a> and/or under applicable legal provisions. Guidelines for suspension of business dealings is available in the webpage: <a href="http://www.bhel.com/vender_registration/vender.php">http://www.bhel.com/vender_registration/vender.php</a>.</p> |  |
| 18 | <p><b><u>PROHIBITED ACTS UNDER COMPETITION ACT, 2002:</u></b></p> <p>All the bidders should desist from doing any acts prohibited under Chapter-II of the Competition Act, 2002. If any such instance is observed during this tender will attract disciplinary action as per BHEL policies.</p>  |  |
| 19 | <p><b><u>IN THE EVENT OF FORCE MAJEURE:</u></b></p> <ol style="list-style-type: none"><li>a. Notwithstanding the provisions contained in other clauses, the supplier shall not be liable for imposition of any such sanction so long the delay and/or failure of the supplier in fulfilling its obligations under the contract is the result of an event of Force Majeure. For purposes of this clause, Force Majeure means an event beyond the control of the supplier and not involving the supplier's fault or negligence and which is not foreseeable and not brought about at the instance of the party claiming to be affected by such event and which has caused the non – performance or delay in performance. Such events may include, but are not restricted to, wars or revolutions, hostility, acts of public enemy, civil commotion, sabotage, fires, floods, explosions, epidemics, quarantine restrictions, strikes excluding by its employees, lockouts excluding by its management, freight embargoes and Acts of GOD.</li><li>b. If a Force Majeure situation arises, the supplier shall promptly notify the Purchaser/Consignee in writing of such conditions and the cause thereof within twenty-one days of occurrence of such event. Unless otherwise directed by the Purchaser/Consignee in writing, the supplier shall continue to perform its obligations under the contract as far as reasonably practical, and shall seek all reasonable alternative means for performance not prevented by the Force Majeure event.</li><li>c. If the performance in whole or in part or any obligation under this contract is prevented or delayed by any reason of Force Majeure for a period exceeding sixty days, either party may at its option terminate the contract without any financial repercussion on either side.</li></ol> <p>In case due to a Force Majeure event the Purchaser/Consignee is unable to fulfil its contractual commitment and responsibility, the Purchaser/Consignee will notify the supplier accordingly and subsequent actions taken on similar lines described in above sub-paragraphs.</p>  |  |
| 20 | <p><b><u>LAWS GOVERNING THE CONTRACT:</u></b></p> <ol style="list-style-type: none"><li>a. The contract shall be governed by the Laws of the Government of India in force.</li></ol>   |  |



**ANNEXURE-A**

**BID SPECIFIC ADDITIONAL TERMS & CONDITIONS FOR THE  
PROCUREMENT OF CS SEAMLESS PIPES FOR IOCL BARAUNI & PANIPAT PROJECTS**

|    |  |  |
|----|--|--|
|    | <p>b. Irrespective of the place of execution of the contract, place of delivery, place of payment under the contract, the contract shall be deemed to have been made at the place at which the Acceptance of the tender has been issued.</p>   |  |
| 21 | <p><b><u>JURISDICTION OF THE COURT</u></b><br/>The Courts of the place from where the acceptance of the tender has been issued shall alone have jurisdiction to decide any dispute arising out of or in respect of the contract.</p>   |  |
| 22 | <p><b><u>RESOLUTION OF DISPUTES:</u></b><br/>The Parties agree that if at any time (whether before, during or after the arbitral or judicial proceedings), any Disputes (which term shall mean and include any dispute, difference, question or disagreement arising in connection with construction, meaning, operation, effect, interpretation or breach of the contract/tender which the Parties are unable to settle mutually), arise inter-se the Parties, the same may, be referred by either party to Conciliation to be conducted through Independent Experts Committee to be appointed by competent authority of BHEL from the BHEL Panel of Conciliators.</p> <p>The proceedings of Conciliation shall broadly be governed by Part-III of the Arbitration and Conciliation Act 1996 or any statutory modification thereof.</p> <p>Notes:</p> <ol style="list-style-type: none"><li>1. No serving or a retired employee of BHEL/Administrative Ministry of BHEL shall be included in the BHEL Panel of Conciliators.</li><li>2. Any other person(s) can be appointed as Conciliator(s) who is/are mutually agreeable to both the parties from outside the BHEL Panel of Conciliators.</li></ol> <p>The proceedings of Conciliation shall broadly be governed by Part-III of the Arbitration and Conciliation Act 1996 or any statutory modification thereof.</p> <p>Except as provided elsewhere in this Contract, in case amicable settlement is not reached between the parties, in respect of any dispute or difference; arising out of the formation, breach, termination, validity or execution of the Contract; or, the respective rights and liabilities of the Parties; or, in relation to interpretation of any provision of the Contract ; or , in any manner touching upon the Contract, then, either Party may , by a notice in writing to other Party refer such dispute or difference to sole arbitration of an arbitrator appointed as per the Arbitration and Conciliation Act, 1996 (India) or statutory modification or re-enactment thereof and the rules made thereunder and for the time being in force.</p> <p>The Arbitrator shall pass a reasoned award and the award of the Arbitrator shall be final and binding upon the parties. Subject as aforesaid, the provision of Arbitration &amp; Conciliation Act 1996 (India) or statutory modification or re-enactment thereof and the rules made thereunder and for the time being in force shall apply to the arbitration proceeding under this clause.</p> <p>The seat of arbitration shall be Chennai, Tamil Nadu, India. The cost of arbitration shall be borne as per the award of the Arbitrator. Subject to arbitration in terms of clause above, the Courts at Chennai, Tamil Nadu, India shall have exclusive jurisdiction over any matter arising out of or in connection with this Contract.</p> <p>Notwithstanding the existence or any dispute or difference and/or reference for the arbitration, the vendor shall proceed with and continue without hindrance the performance of its obligation under this Contract with due diligence and expedition in a professional manner except where the Contract has been terminated by either Party in terms of this Contract.</p> <p><b><u>In Case of Contract with Public Sector Enterprise (PSE) or a Government Department, the following shall be applicable:</u></b><br/>In the event of any dispute or difference relating to the interpretation and application of the provisions of commercial contract(s) between Central Public Sector Enterprises (CPSEs)/Port Trusts inter se and also between CPSEs and Government Departments/Organizations (Excluding disputes concerning Railways, Income Tax, Customs &amp; Excise Departments, such dispute or difference shall be taken up by either party for resolution through AMRCD as mentioned in DPE OM No. 4(1)/2013 –DPE (GM)/FTS-1835 dated 22-05-2018.</p> |  |

**ANNEXURE-A**

**BID SPECIFIC ADDITIONAL TERMS & CONDITIONS FOR THE  
PROCUREMENT OF CS SEAMLESS PIPES FOR IOCL BARAUNI & PANIPAT PROJECTS**

|    |   |  |
|----|---|--|
| 23 | <p><b><u>SET-OFF CLAUSE:</u></b></p> <p>BHEL, Piping Centre, Chennai shall have the right to recover any money which in the sole opinion of BHEL is due from the Contractor from any money due to the Contractor like Payment of bills, payment of any amounts due, release of Security Deposit or return of Bank Guarantees furnished</p> <ul style="list-style-type: none"><li>a. Under this tender/contract <b>(OR)</b></li><li>b. Any other contract placed on the contractor by BHEL, Piping centre, Chennai <b>(OR)</b></li><li>c. Any other contract placed on the contractor by any Unit/s of BHEL</li></ul> <p>BHEL, Piping Centre, Chennai also reserves the right to set off the amount of the contractor available in any form, against any claims of any other contract with BHEL.</p>   |  |
| 24 | <p><b><u>CAUTION:</u></b></p> <p>a) The suppliers are severely cautioned to note that the price bid document accepts the price in figures only. It does not allow the supplier to write the value by words. Therefore, all care shall be exercised by the supplier while filling in the figures. Once the price bid is opened no option is available for the supplier to retract the offer under any grounds. If a supplier, for any reason whatsoever approaches BHEL with a request for change in the price, it would be treated as going back on the offer submitted. In such cases, action would be initiated by BHEL for suspending further business dealings with such suppliers as per policy of BHEL which prevails at that point of time.</p> <p>b) The language in the tender documents downloaded by the Bidders shall at no point of time be changed, altered or modified in any manner by the Tenderer. If such changes are made by any tenderer, it shall be considered as tampering with BHEL's terms and the offer shall be summarily rejected, whenever it is noticed by BHEL. Such Bidders would be disqualified from the Bidding Process and their offers would be forfeited / Bank Guarantees invoked. They would also not be allowed to participate in future tenders of BHEL.</p>   |  |
| 25 | <p><b><u>GENERAL:</u></b></p> <ul style="list-style-type: none"><li>i. The PO copy with all details will be given to successful bidders in soft mode only.</li><li>ii. Acknowledgement for receipt of PO shall be sent within one week from the date of receipt.</li><li>iii. BHEL reserves the right to cancel this tender without assigning any reasons what so ever.</li><li>iv. Deviation taken after placement of order will not be accepted (Both technical as well as on delivery).</li><li>v. Suppliers to analyze in detail, at the time of submission of offer with reference to our "delivery" requirement of item and confirm compliance.</li><li>vi. BHEL reserves the right to negotiate or re-float the tender opened, if L1 price / other details are not acceptable to them.</li><li>vii. Any other terms or conditions mentioned in your offer other than the above mentioned formats will not be evaluated and will be considered null &amp; void. Hence your offer shall contain ONLY the above mentioned formats.</li><li>viii. Bids not accepting to above conditions will be liable for rejection.</li><li>ix. For verification of data submitted towards evaluation of bidder's capability, BHEL may decide to visit the bidder(s) works. Any fact found deviating from submitted data shall make the bidder liable to be disqualified.</li></ul> |  |
| 26 | <p><b><u>ENCLOSURES:</u></b></p> <div style="display: flex; justify-content: space-around; align-items: center;"><div style="text-align: center;"><br/>Technical requirements for Ba</div><div style="text-align: center;"><br/>Technical requirements for Pa</div><div style="text-align: center;"><br/>Annexures to Bid specific ATC.pdf</div></div>   |  |

## Annexure-B

### SUPPLY OF CS SEAMLESS PIPES FOR IOCL BARAUNI & PANIPAT PROJECTS

| List of Customer approved Indian MAKES – Carbon Steel to ASTM standards – IOCL BARAUNI PROJECT |   |
|--|---|
| SI No.   | Name  |
| 1  | HEAVY METAL & TUBES (INDIA) PRIVATE LIMITED |
| 2  | ISMT LTD                                    |
| 3  | JINDAL SAW LTD                              |
| 4  | MAHARASHTRA SEAMLESS LTD.                   |

| List of Customer approved Indian Manufacturers – Carbon Steel to ASTM standards – IOCL PANIPAT PROJECT |   |
|--|---|
| SI No.   | Name  |
| 1  | ANAND SEAMLESS TUBES PVT. LTD               |
| 2  | AVON TUBETECH PVT LTD                       |
| 3  | HEAVY METAL & TUBES (INDIA) PRIVATE LIMITED |
| 4  | ISMT LTD-AHMEDNAGAR                         |
| 5  | JINDAL SAW LTD (NASHIK WORKS)               |
| 6  | JR SEAMLESS PVT.LTD                         |
| 7  | LAL BABA SEAMLESS TUBES PVT. LTD            |
| 8  | MAHARASHTRA SEAMLESS LTD.                   |
| 9  | PATELS AIRFLOW LTD.                         |
| 10   | RATNADEEP METAL AND TUBES LTD.              |
| 11   | SAINEST TUBES PVT LTD                       |
| 12   | SN TUBES PRIVATE LIMITED                    |
| 13   | BHARAT HEAVY ELECTRICALS LIMITED            |

| List of Customer approved Indian STOCKISTS applicable for IOCL Panipat |  |
|--|--|
| SI No.   | Name   |
| 1  | BHARAT ENTERPRISES                               |
| 2  | EVERGREEN SEAMLESS PIPES & TUBES PRIVATE LIMITED |
| 3  | HI TECH METAL AND TUBES                          |
| 4  | INDUSTRIAL METAL CORPORATION                     |
| 5  | KWALITY TUBES                                    |
| 6  | MOKSHI INDUSTRIES PVT. LTD                       |
| 7  | MOTILAL LAXMICHAND SANGHAVI                      |
| 8  | N-PIPE SOLUTIONS INC                             |
| 9  | PIPES AND FLOW PRODUCTS                          |
| 10   | PK FORGE & FITTINGS INDUSTRIES                   |
| 11   | RAJENDRA PIPING & FITTINGS                       |
| 12   | SADAF TRADING COMPANY                            |
| 13   | STAR METAL AND TUBES                             |
| 14   | VENUS TRADING COMPANY                            |
| 15   | VINAYAK PIPES & TUBES PVT LTD                    |
| 16   | SEVANTILAL & SONS PVT. LTD                       |
| 17   | SUPERIOR STEEL INDUSTRIES                        |

**Note:**

Stockists shall Supply Make of Pipe as per Approved Makes / Manufacturers List mentioned above for the respective material grades procured.

**UNPRICED BID – SUPPLY OF CS SEAMLESS PIPES FOR IOCL BARAUNI & PANIPAT PROJECTS**

| Schedule ref | Item No | Item Description  | WORK ORDER - DU DETAIL | Qty in Meters | Applicable Drawing Number  | F.O.R Destination         | OEM / Stockist (if stockist mention the OEM from which items are proposed to be supplied) | Quoted / Not Quoted |
|--------------|---------|---|------------------------|---------------|----------------------------|---------------------------|---|---------------------|
| Schedule 1   | 1       | PIPE OD 219.10 x 8.18 A106GR.B SMLS BE ASME B36.10M                 | P7471180998006         | 12            | 4-80-998-84399, Sl. No. 06 | IOCL Barauni Project Site |   |                     |
| Schedule 1   | 2       | PIPE OD 88.9X5.49 A106GR.B – GALV & THREADED SMLS BE ASME B36.10M   | P7471180998007         | 66            | 4-80-998-84399, Sl. No. 07 | IOCL Barauni Project Site |   |                     |
| Schedule 1   | 3       | PIPE OD 26.7 X 5.56 A106GR.B SMLS PE ASME B36.10M HIC NACE HYDROGEN | P7471180998008         | 6             | 4-80-998-84402, Sl. No. 01 | IOCL Barauni Project Site |   |                     |
| Schedule 1   | 4       | PIPE OD 26.7 X 5.56 A106GR.B SMLS PE ASME B36.10M HIC NACE          | P7471180998009         | 36            | 4-80-998-84402, Sl. No. 02 | IOCL Barauni Project Site |   |                     |
| Schedule 1   | 5       | PIPE OD 26.7 X 5.56 A106GR.B SMLS PE ASME B36.10M NACE              | P7471180998010         | 93            | 4-80-998-84402, Sl. No. 03 | IOCL Barauni Project Site |   |                     |
| Schedule 1   | 6       | PIPE OD 26.7 X 5.56 A106GR.B SMLS PE ASME B36.10M HYDROGEN          | P7471180998011         | 36            | 4-80-998-84402, Sl. No. 04 | IOCL Barauni Project Site |   |                     |
| Schedule 1   | 7       | PIPE OD 60.3 x 8.74 A106GR.B SMLS BE ASME B36.10M NACE              | P7471180998012         | 12            | 4-80-998-84402, Sl. No. 05 | IOCL Barauni Project Site |   |                     |
| Schedule 1   | 8       | PIPE DIA 114.3 X 6.02 A106GR.B SMLS BE ASME B36.10M HYDROGEN        | P7471180998013         | 6             | 4-80-998-84402, Sl. No. 06 | IOCL Barauni Project Site |   |                     |
| Schedule 1   | 9       | PIPE OD 219.10 x 8.18 A106GR.B SMLS BE ASME B36.10M HYDROGEN        | P7471180998014         | 12            | 4-80-998-84402, Sl. No. 07 | IOCL Barauni Project Site |   |                     |
| Schedule 1   | 10      | PIPE OD 26.7 X 5.56 A333GR.6 SMLS PE ASME B36.10M                   | P7471180998015         | 48            | 4-80-998-84415, Sl. No. 01 | IOCL Barauni Project Site |   |                     |
| Schedule 1   | 11      | PIPE OD88.9X5.49 A333GR.6 SMLS BE ASME B36.10M HIC NACE             | P7471180998016         | 6             | 4-80-998-84415, Sl. No. 02 | IOCL Barauni Project Site |   |                     |
| Schedule 1   | 12      | PIPE OD114.3X6.02 A333GR.6 SMLS BE ASME B36.10M                     | P7471180998017         | 21            | 4-80-998-84415, Sl. No. 03 | IOCL Barauni Project Site |   |                     |
| Schedule 1   | 13      | PIPE OD26.7X5.56 A106GR.B – GALV & THREADED SMLS TE ASME B36.10M    | P7471180998018         | 33            | 4-80-998-84415, Sl. No. 04 | IOCL Barauni Project Site |   |                     |
| Schedule 2   | 1       | PIPE OD457.2 X 23.88, ASTM A106 GRB                                 | P7470180997002         | 30            | 4-80-997-84475             | IOCL Panipat Project Site |   |                     |

For Company Name:

Signature:

Seal:

**CHECK LIST – SUPPLY OF CS SEAMLESS PIPES FOR IOCL BARAUNI & PANIPAT PROJECTS**

**NOTE: - Tenderers are required to fill in the following details and no column should be left blank**

|     |   |   |                                |
|-----|---|---|--------------------------------|
| 1   | Name and Address of the Bidder  |   |                                |
| 2   | Details about type of the Firm/Company  | Proprietorship / Partnership / Private / Others                                     |                                |
| 3.a | Details of Contact person for this Tender   | Name : Mr/Ms<br>Designation:<br>Telephone No:<br>Mobile No:<br>Email ID:<br>Fax No: |                                |
| 3.b | Details of alternate Contact person for this Tender   | Name : Mr/Ms<br>Designation:<br>Telephone No:<br>Mobile No:<br>Email ID:<br>Fax No: |                                |
|     |   | APPLICABILITY<br>(BY BHEL)  | ENCLOSED /<br>AGREED BY BIDDER |
| 4   | Whether the format for compliance with <b>PRE QUALIFICATION CRITERIA (Annexure-G)</b> is understood and filled with proper supporting documents referenced in the specified format? | Applicable  | YES/NO                         |
| 5   | Audited Balance sheet, Profit and Loss Account for the last FOUR years  | Applicable  | YES/NO                         |
| 6   | Whether all pages of the Tender documents including annexures, appendices etc. are read and understood? Signed copy of <b>Annexure-A</b> enclosed?                                  | Applicable  | YES/NO                         |
| 7   | If Stockist, Whether agreed to source pipes from the Indian Manufacturers mentioned in <b>Annexure-B</b> ?  | Applicable  | YES/NO                         |
| 8   | Whether duly filled and signed unpriced bid <b>Annexure-C</b> enclosed?   | Applicable  | YES/NO                         |
| 9   | Whether MII Purchase preference applicable? If Yes, duly filled and signed <b>Annexure-E</b> enclosed?  | Applicable  | YES/NO                         |
| 10  | Whether MSE Purchase Preference Applicable? If Yes, whether <b>Udyam Registration certificate</b> enclosed?   | Applicable  | YES/NO                         |
| 11  | Whether signed NDA format ( <b>Annexure-F</b> ) enclosed?   | Applicable  | YES/NO                         |
| 12  | Copy of PAN Card & GST Registration Certificate   | Applicable  | YES/NO                         |
| 13  | Bank Account Details for E-Payment  | Applicable  | YES/NO                         |

**NOTE: STRIKE OFF 'YES' OR 'NO', AS APPLICABLE. TENDER NOT ACCOMPANIED BY THE PRESCRIBED ABOVE APPLICABLE DOCUMENTS ARE LIABLE FOR REJECTION.**

**DATE:**

**AUTHORISED SIGNATORY**

(With Name, Designation and Company seal)

**Declaration format for Make in India to be issued on Bidder's Company letter head  
– SUPPLY OF CS SEAMLESS PIPES FOR IOCL BARAUNI & PANIPAT PROJECTS**

**Self-Declaration**

|                     |  |
|---------------------|--|
| <b>Enquiry No.</b>  |  |
| <b>Enquiry Date</b> |  |

In line with Government public procurement order Number P45021/2/2017-B.E-II dated 15.06.2017, and further modified order dt. 28.05.2018 & order 04.06.2020 issued by DPIIT

I / We hereby declare that I / We are a “Local Supplier” meeting the requirement of minimum local content (.....%) defined in the above government notification for the goods against above mentioned enquiry Number.

Details of location at which local value addition will be made is as follows:

|                    |  |
|--------------------|--|
| Door No.           |  |
| Street / Address 1 |  |
| Street / Address 2 |  |
| District           |  |
| State              |  |
| Country            |  |
| PIN Code           |  |

By issuing this declaration, we understand and are in acceptance to the following-

- False declarations will be in breach of the Code of Integrity under Rule 175(1)(i)(h) of the General Financial Rules for which a bidder or its successors can be debarred for up to two years as per Rule 151 (iii) of the General Financial Rules along with such other actions as may be permissible under law.
- In case of debarment by any procuring entity for violation of the provisions of the Public Procurement (Preference to Make in India), Order 2017 we shall not be eligible for preference for procurement by any other procuring entity for the duration of the debarment. The debarment for such other procuring entities shall take effect prospectively from the date on which it comes to the notice of other procurement entities, the debarment takes effect prospectively from the date of uploading on the website(s) of The Department of Expenditure, GOI in such a manner that ongoing procurements are not disrupted.
- We undertake the onus of responsibility of submission of appropriately certified documents. We understand that BHEL is not at liability to verify the contents and will not be responsible for the declaration made by us. However, in case BHEL has any reason to doubt the authenticity of the local content, BHEL reserves the right to obtain the complete back up calculations before award of contract and we are liable to submit the same if

**Declaration format for Make in India to be issued on Bidder's Company letter head  
– SUPPLY OF CS SEAMLESS PIPES FOR IOCL BARAUNI & PANIPAT PROJECTS**

requested by BHEL. We also understand that our bid is liable for rejection in case we fail to submit the details as requested by BHEL.

**Special Note-**

In cases of procurement for a value in excess of Rs. 10 crores, the local supplier shall be required to provide a certificate from the statutory auditor or cost auditor of the company (in the case of companies) or from a practicing cost accountant or practicing chartered accountant (in respect of suppliers other than companies) giving the percentage of local content.

For Company Name:

Seal:

Signature:

Date:

Place:

(Please fill all the yellow colour fields)

**BHARAT HEAVY ELECTRICALS LIMITED**  
PIPING CENTRE, PURCHASE  
BHEL / CHENNAI – 600 017

THIRD PARTY NON-DISCLOSURE AGREEMENT

I, \_\_\_\_\_, on behalf of the \_\_\_\_\_ (Name of Company), acknowledge that the information received or generated, directly or indirectly, while working with BHEL, Piping Centre, Chennai on contract is confidential and that the nature of the business of the BHEL, Piping Centre, Chennai is such that the following conditions are reasonable, and therefore:

I warrant and agree as follows:

I, or any other personnel employed or engaged by our company, agree not to disclose, directly or indirectly, any information related to the BHEL, Piping Centre, Chennai Without restricting the generality of the foregoing, it is agreed that we will not disclose such information consisting but not necessarily limited to:

- Technical information: Methods, drawings, processes, formulae, compositions, systems, techniques, inventions, computer programs/data/configuration and research projects.
- Business information: Customer lists, project schedules, pricing data, estimates, financial or marketing data.

On conclusion of contract, I, or any other personnel employed or engaged by our company shall return to BHEL, Piping Centre, Chennai all documents and property of BHEL, Piping Centre, Chennai, including: drawings, blueprints, reports, manuals, computer programs/data/configuration, and all other materials and all copies thereof relating in any way to BHEL, Piping Centre, Chennai's business, or in any way obtained by me during the course of contract. I further agree that I, or any others employed or engaged by our company shall not retain copies, notes or abstracts of the foregoing.

This obligation of confidence shall continue after the conclusion of the contract also.

I acknowledge that the aforesaid restrictions are necessary and fundamental to the business of the BHEL, Piping Centre, Chennai and are reasonable given the nature of the business carried on by the BHEL, Piping Centre, Chennai I agree that this agreement shall be governed by and construed in accordance with the laws of country.

I enter into this agreement totally voluntarily, with full knowledge of its meaning, and without duress.

Dated at \_\_\_\_\_, this \_\_\_\_ day of \_\_\_\_\_, 20\_\_.

Name

Company

Signature

**PRE – QUALIFICATION REQUIREMENT (PQR) FOR SUPPLY OF CS SEAMLESS PIPES FOR IOCL BARAUNI & PANIPAT PROJECTS**

| SI No. | PQR Description   | Documents to be submitted  | ** Bidder response (Submitted / Not submitted) |
|--------|---|--|--|
| 1      | <p><b><u>EXPERIENCE CRITERIA:</u></b></p> <p>Bidder shall have prior experience in supply of seamless pipes to Carbon Steel specification as per tender.</p> <p>Qualification for respective pipe specification:</p> <p>a. For Carbon Steel pipes of spec A106GrB / SA106GrB - Experience in supply of CS pipes to spec GrB / Gr6 or in higher grades of Carbon / Alloy steel like GrC / P11 / P12 / P22 / P91 / P92 as per ASTM / ASME standards are acceptable.</p> <p>b. For Carbon Steel pipes of spec A333Gr6 / SA333Gr6 - Experience in supply of CS pipes to spec A333Gr6 / SA333Gr6 is acceptable. Any other grade of CS / AS is not acceptable.</p> <p>Supply experience being furnished shall not be prior to 4 years from the date of the Enquiry. Supply Experience POST part-1 bid opening date shall not be considered.</p> | <p>PO copies &amp; Inspection release note from any Customer shall be submitted.</p> <p>End customer details shall be provided to verify the performance, if required.</p>   |  |
| 2      | <p><b><u>FINANCIAL SOUNDNESS:</u></b></p> <p>Bidder should have made a turnover of at least Rs. 6 lakhs for anyone of last 4 audited Financial Years.</p> <p>Start-up which has commenced operations only in the current Financial year (FY 2022-23) but meeting financial turnover criteria shall submit certificate from CA certifying the turnover made up to the current month of FY (FY 2022-23).</p>  | <p>Audited Balance Sheet and Audited Profit &amp; Loss Account for the past four financial years.</p> <p>In case bidders have commenced operations within the past 4 years from the date of enquiry, audited Balance Sheet and P&amp;L statement for the available years shall be submitted.</p> |  |

**\*\* Supporting documents to be enclosed without fail.**

**Note –**

1. Bids fulfilling the above criteria will be considered for further techno-commercial evaluation.
2. For Startups and MSE bidders, Annual Financial Turnover criteria (SI. No: 2 above) is relaxed by 50%, during anyone of the Financial years in the past 4 years and prior experience criteria (SI. No: 1 above) is relaxed to last 5 years from the date of Enquiry.
3. Relaxation is subject to bidder meeting technical and quality criteria of the PQR. **Relaxation is applicable for Manufacturers only.** Bidders proposing to avail relaxation as above need to submit necessary document proof along with Pre-Qualification bid.

**PRE – QUALIFICATION REQUIREMENT (PQR) FOR SUPPLY OF CS SEAMLESS PIPES FOR IOCL BARAUNI & PANIPAT PROJECTS**

- a) Startups - Certificate of Recognition by Department of Industrial Policy & Promotion
  - b) MSE – Udyam Registration certificate
4. Bidder to submit all supporting documents in English language. If documents submitted by bidder are in a language other than English, a self-attested English translated document shall also be submitted.
5. Bidders referred to NCLT, NCLAT or firms having strictures / hold by any other Government agency will not be considered.

For Company Name:

Seal:

Signature:

|                     |  |
|---------------------|--|
| 7471:SCC:001        | Special Contract Conditions<br>Project : IOCL Barauni Piping |
| Rev 00 DTD.22.02.22 | Item : SEAMLESS PIPES  |

**Item : Pipes A106GrB, A333Gr6, A106GrB/Galvanised**

1. All supplies shall confirm to the requirements of the relevant ASTM / ASME standards.
2. All supplies made in this contract shall also **compulsorily** meet the **special contract conditions** as mentioned in the approved QAP under **Raw material clause, Remarks column, Notes section etc.**
3. All tests as mentioned in the approved QAP 7471:QPC:01:Rev 04 and requirements as per the attached Annexures to the QAP shall also be met.

**MANUFACTURING QUALITY PLAN FOR SUPPLY OF  
SEAMLESS CARBON STEEL PIPES**

DOC. NO.: DOC. NO.: EPCM25&26-IBCE158-C00-ISP-ITP-000-0001



--: OWNER :--  
**INDIAN OIL CORPORATION LIMITED**



--: PMC :--  
**TOYO ENGINEERING INDIA PRIVATE LIMITED**





--: VENDOR :--  
**BHARAT HEAVY ELECTRICALS LIMITED**



reviewed

| For Toyo Engineering India Pvt. Ltd. (PMC) use only  |  |                                   |       |
|--|--|-----------------------------------|-------|
|  | TOYO ENGINEERING INDIA PVT. LTD.<br>MUMBAI - 400 078 |                                   |       |
| A  | Approved/ Reviewed                                   | No Comments                       |       |
| B  | Reviewed with comment                                | Document needs to be resubmitted  |       |
| C  | Not Approved   | Document needs to be resubmitted  |       |
| D  | Not for Approval                                     | Retained for Information/ Records |       |
| DATE   |  | TOYO Job No.                      |       |
| SIGN   | AE   | LAE                               | TM/DH |
| NOTE: Review by PMC/TOYO whether or not resulting in comments shall not relieve Contractor of any obligations or requirements under the contract and it shall not be construed as an authorization of or consent to any deviation from contract. |  |                                   |       |



|            |             |                    |                    |                   |                    |
|------------|-------------|--------------------|--------------------|-------------------|--------------------|
| 04         | 13.10.2021  | For Approval       | Babu Hariharan G   | D.Sandra Priya    | K.V. Ramani        |
| 03         | 14.09.2021  | For Approval       | Babu Hariharan G   | D.Sandra Priya    | K.V. Ramani        |
| 02         | 12.07.2021  | For Approval       | Babu Hariharan G   | D.Sandra Priya    | K.V. Ramani        |
| 01         | 09.07.2021  | For Approval       | Babu Hariharan G   | D.Sandra Priya    | K.V. Ramani        |
| 00         | 30.06.2021  | Issued for Review  | Babu Hariharan G   | D.Sandra Priya    | K.V. Ramani        |
| <b>REV</b> | <b>DATE</b> | <b>DESCRIPTION</b> | <b>PREPARED BY</b> | <b>CHECKED BY</b> | <b>APPROVED BY</b> |

|   |   |   |  |
|---|---|---|--|
| <b>OWNER</b><br><br><b>IndianOil</b> | <b>PMC</b><br><br><b>TOYO</b><br>ENGINEERING | <b>MANUFACTURING QUALITY PLAN<br/>         FOR SUPPLY OF<br/>         SEAMLESS CARBON STEEL PIPES</b> | <b>VENDOR</b><br> |
| ISSUED : 30.06.2021   |   | DOC. NO.: EPCM25&26-IBCE158-C00-ISP-<br>ITP-000-0001  | PAGE 2 OF 14   |

| <b>REVISION HISTORY</b> |   |
|-------------------------|---|
| <b>REV.</b>             | <b>REVISION DESCRIPTION</b>             |
| 00                      | FOR REVIEW                              |
| 01                      | CLIENTS COMMENTS ARE INCORPORATED       |
| 02                      | CLIENTS COMMENTS ARE INCORPORATED       |
| 03                      | TPIA COMMENTS ARE INCORPORATED          |
| 04                      | HYDRO TEST INCLUDED IN FINAL INSPECTION |



reviewed



|  |   |  |  |
|--|---|--|--|
| <p><b>OWNER</b></p>  <p>IndianOil</p> | <p><b>PMC</b></p>  <p>TOYO<br/>ENGINEERING</p> | <p><b>MANUFACTURING QUALITY PLAN<br/>FOR SUPPLY OF<br/>SEAMLESS CARBON STEEL PIPES</b></p> | <p><b>VENDOR</b></p>  |
| <p>ISSUED : 30.06.2021</p>   |   | <p>DOC. NO.: EPCM25&amp;26-IBCE158-C00-ISP-<br/>ITP-000-0001</p>                           | <p>PAGE 3 OF 14</p>  |

**CONTENTS**

| SL.NO | DESCRIPTION  | PAGE NO |
|-------|--|---------|
| 1     | Manufacturing, Inspection and Testing QP for supply of seamless CS pipes | 4-10    |
| 2     | Annexure -1  | 11      |
| 3     | Annexure -2  | 12      |
| 4     | Annexure -3  | 13      |
| 5     | Annexure -4  | 14      |

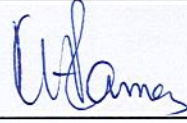

reviewed

| S. No   |   | COMPONENT & OPERATIONS  | CHARACTERISTICS | CLASS   | TYPE OF CHECK  | REFERENCE DOCUMENT  | ACCEPTANCE NORMS   | FORMAT OF RECORDS | AGENCY  |   | REMARKS |
|---|---|---|-----------------|---|--|---|--|-------------------|---|---|---------|
| 1   |   | 2   | 3               | 4   | 5  | 6   | 7  | 8                 | M   | B   | 10      |
| <b>MANUFACTURING, INSPECTION AND TESTING QP FOR SUPPLY OF SEAMLESS CARBON STEEL PIPES</b>   |   |   |                 |   |  |   |  |                   |   |   |         |
|    |   | <b>MANUFACTURER'S NAME &amp; ADDRESS</b><br>BHEL PIPING CENTRE, CHENNAI<br>BHEL'S MANUFACTURING SHOPS<br>BHEL / CUSTOMER APPROVED VENDORS |                 |   | <b>SEAMLESS CARBON STEEL PIPES (ASTM A333 GR.6 &amp; ASME SA106 GRB)</b> |   | <b>QP No:</b> 7471:QPC:01<br><b>REV No:</b> 04<br><b>DATED:</b> 13.10.2021<br><b>MRQ NO.:</b> IBCE-6373-491-PIP-MRQ-AXHA101A |                   | <b>OWNER :</b> IOCL, Barauni<br><b>PROJECT REF :</b> IBCE/158/26882921<br><b>DATED:</b> 16-03-2021<br><b>PMC :</b> TOYO ENGINEERING INDIA PVT. LTD.<br><b>MAIN-SUPPLIER:</b> BHEL-PIPING CENTRE<br><b>BHEL CUSTOMER No:</b> P1 / 7471 |   |         |
| <b>1.0 RAW MATERIAL:</b>  |   |   |                 |   |  |   |  |                   |   |   |         |
| 1. All pipe shall be of /from Project approved Manufacturer Supplier List.<br>2. Refer Note 2 if procured from Stockist / dealer.<br>3. Refer Note 14,15,16 for special requirements during manufacturing |   |   |                 |   |  |   |  |                   |   |   |         |
| 1.1   | Ingot (applicable for Purchased-Direct To Site pipes)   | i)Chemical test<br>ii)Mechanical test   | Critical        | TC verification   | ASTM/ASME/NACE Standard MR0103<br>Material specification in BHEL GMS/DRG | Mfg Tc  | D  | P                 | R   | a) Steel made by Acid Bessemer process is not acceptable.<br>b) Carbon content shall be as per Note 1<br><b>c) Material test reports shall be Type 3.1 according to EN10204</b><br>d) 100% NDT (MT) is required for Seamless pipe manufactured by "Hot" Pilger Mill process.<br>e)Other than "Hot" Pilger mill Process , NDT not applicable<br>f) MT & UT procedure reviewed & Approved by qualified Level III personal |         |
| 1.2   | Seamless Steel Pipes.(applicable for BHEL manufactured pipes and Pipes procured from Stockists) | i) Chemical test<br>ii) Mechanical test<br>iii) Hardness (Max 200 BHN)<br>iv) NDE (remark d,e,f)  | Critical        | TC verification   | ASTM/ASME/NACE Standard MR0103<br>Material specification in BHEL GMS/DRG | Mfg Tc  | D  | P                 | R   |   |         |
| FOR MANUFACTURER USE:   |   |   |                 |   |  | FOR TPIA USE ( If required):  |  |                   | FOR CUSTOMER USE:   |   |         |
|    |   |    |                 |  |  | M : BHEL / VENDOR;<br>B : BHEL TPIA (from Customer approved TPIA list);<br>H : HOLD POINT (NOT TO PROCEED WITHOUT CLEARANCE)<br>P : PERFORM (100%), V : VERIFY,<br>W : WITNESS (100%), RW : RANDOM WITNESS<br>R : DOCUMENT REVIEW ONLY.<br>D-REPORTS TO BE ESSENTIALLY INCLUDED IN DOCUMENTATION. |  |                   |   |   |         |
| Babu Hariharan G, DM/Q&BE   |   | D.Sandra Priya, DM/Q&BE   |                 | K.V.Ramani AGM/Q&BE   |  |   |  |                   |   |   |         |
| PREPARED BY   |   | REVIEWED BY   |                 | APPROVED BY   |  | APPROVED BY (NAME & SEAL)   |  |                   | APPROVED BY (NAME & SEAL)   |   |         |



reviewed

| S. No   |                         | COMPONENT & OPERATIONS  | CHARACTERISTICS | CLASS   | TYPE OF CHECK                  | REFERENCE DOCUMENT  | ACCEPTANCE NORMS | FORMAT OF RECORDS  | AGENCY |                           | REMARKS  |  |
|---|-------------------------|---|-----------------|---|--------------------------------|---|------------------|--|--------|---------------------------|--|--|
| 1   |                         | 2   | 3               | 4   | 5                              | 6   | 7                | 8  | M      | B                         | 10   |  |
|  <b>MANUFACTURER'S NAME &amp; ADDRESS</b><br>BHEL PIPING CENTRE, CHENNAI<br>BHEL'S MANUFACTURING SHOPS<br>BHEL / CUSTOMER APPROVED VENDORS |                         |   |                 |   |                                |   |                  |  |        |                           |  |  |
| <b>SEAMLESS CARBON STEEL PIPES (ASTM A333 GR.6 &amp; ASME SA106 GRB)</b>  |                         |   |                 |   |                                | <b>QP No:</b> 7471:QPC:01<br><b>REV No:</b> 04<br><b>DATED</b> 13.10.2021<br><b>MRQ NO.:</b> IBCE-6373-491-PIP-MRQ-AXHA101A |                  | <b>OWNER :</b> IOCL, Barauni<br><b>PROJECT REF :</b> IBCE/158/26882921<br><b>DATED</b> 16-03-2021<br><b>PMC :</b> TOYO ENGINEERING INDIA PVT. LTD.<br><b>MAIN-SUPPLIER:</b> BHEL-PIPING CENTRE<br><b>BHEL CUSTOMER No:</b> P1 / 7471 |        |                           |  |  |
| <b>2.0 INPROCESS - (2.1 to 2.5 - applicable for Purchased-Direct To Site pipes)</b>   |                         |   |                 |   |                                |   |                  |  |        |                           |  |  |
| 2.1   | Marking & Melt transfer | Melt verification & Co rerelation with Material TC            | Minor           | Visual & Measurement  | TC& BHEL Drawing / ASME B36.10 | HC  | -                | P  | V      |                           | HC - History Card of Item  |  |
| 2.2   |                         | Test piece marking  | Major           | Verification  | TC& BHEL Drawing / ASME B36.10 | Report  |                  | P  | H      |                           |  |  |
| 2.3   | Product Analysis        | Chemical Testing  | Major           | Lab test  | ASTM/ASME/NACE Standard MR0103 | Report  | D                | P  | R      |                           |  |  |
| 2.4   | Mechanical Testing      | Tensile, Impact test, Hardness, Microstructure                | Major           | Lab test  |                                | Report  | D                | P  | H      |                           | <b>For A333 Gr6 Impact testing shall be done as per ASME Std. Material specification</b> |  |
| 2.5   | Edge Preparation        | End finish of pipes shall be in accordance with ASME B 16.25. |                 |   |                                |   |                  |  |        |                           |  |  |
| 2.6   | NDE - Bevel Ends        | Surface & Internal imperfection                               | Major           | MT (100%)   | ASME SEC V ARTICLE 7           | Report  | D                | P  | W      |                           | 10% witness by TPIA, 100% by Manufacturer  |  |
| FOR MANUFACTURER USE:   |                         |   |                 |   | LEGEND:                        |   |                  | FOR TPIA USE ( If required):   |        | FOR CUSTOMER USE:         |  |  |
|   |                         |   |                 | M : BHEL / VENDOR;<br>B : BHEL TPIA (from Customer approved TPIA list);<br>H : HOLD POINT (NOT TO PROCEED WITHOUT CLEARANCE)<br>P : PERFORM (100%), V : VERIFY,<br>W : WITNESS (100%), RW : RANDOM WITNESS<br>R : DOCUMENT REVIEW ONLY.<br>D-REPORTS TO BE ESSENTIALLY INCLUDED IN DOCUMENTATION. |                                |   |                  |  |        |                           |  |  |
| Babu Hariharan G, DM/Q&BE   |                         | D.Sandra Priya, DM/Q&BE                                       |                 | K.V.Ramani AGM/Q&BE   |                                |   |                  |  |        |                           |  |  |
| PREPARED BY   |                         | REVIEWED BY   |                 | APPROVED BY   |                                |   |                  | APPROVED BY (NAME & SEAL)  |        | APPROVED BY (NAME & SEAL) |  |  |

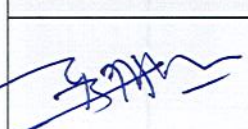
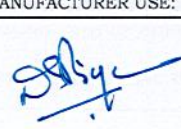
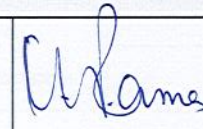

reviewed

| S. No  |                                   | COMPONENT & OPERATIONS                                | CHARACTERISTICS  | CLASS                    | TYPE OF CHECK  | REFERENCE DOCUMENT   | ACCEPTANCE NORMS   | FORMAT OF RECORDS | AGENCY  |   | REMARKS                   |  |
|--|-----------------------------------|---|--|--------------------------|--|--|--|-------------------|---|---|---------------------------|--|
| 1  |                                   | 2   | 3  | 4                        | 5  | 6  | 7  | 8                 | M   | B   | 10                        |  |
| <div style="display: flex; justify-content: space-between;"> <div style="width: 15%;">  </div> <div style="width: 30%;"> <b>MANUFACTURER'S NAME &amp; ADDRESS</b><br/>           BHEL PIPING CENTRE, CHENNAI<br/>           BHEL'S MANUFACTURING SHOPS<br/>           BHEL / CUSTOMER APPROVED VENDORS         </div> <div style="width: 55%; text-align: center;"> <b>MANUFACTURING, INSPECTION AND TESTING QP FOR SUPPLY OF SEAMLESS CARBON STEEL PIPES</b> </div> </div> |                                   |   |  |                          |  |  |  |                   |   |   |                           |  |
| <b>SEAMLESS CARBON STEEL PIPES (ASTM A333 GR.6 &amp; ASME SA106 GRB)</b>   |                                   |   |  |                          |  | <b>QP No:</b> 7471:QPC:01<br><b>REV No:</b> 04<br><b>DATED:</b> 13.10.2021<br><b>MRQ NO.:</b> IBCE-6373-491-PIP-MRQ-AXHA101A | <b>OWNER:</b> IOCL, Barauni<br><b>PROJECT REF:</b> IBCE/158/26882921<br><b>DATED:</b> 16-03-2021<br><b>PMC:</b> TOYO ENGINEERING INDIA PVT. LTD.<br><b>MAIN-SUPPLIER:</b> BHEL-PIPING CENTRE<br><b>BHEL CUSTOMER No:</b> P1 / 7471 |                   |   |   |                           |  |
| <b>3.0 FINAL INSPECTION:</b>   |                                   |   |  |                          |  |  |  |                   |   |   |                           |  |
| 3.1  | Hydro Test                        | Hydro Test  | Major  | HT (100%)                | ASTM A106GRB / A333GR.6 / A53  | Report   | D  | P                 | W   | 10% witness by TPIA, 100% by Manufacturer.<br><b>If Pipes are procured from Stockist / Traders, then 100% witness of Hydro by TPIA.</b>   |                           |  |
| 3.2  | Dimension & visual                | OD,Thickness,Length,EP style,EP d1,Galv DFT check etc | Major  | Measurement              | Drawing/ In process records  | Report   | D  | P                 | H   | 10 % witness by TPIA<br>100% by Manufacturer<br><br><b>100% Visual Inspection - witness by TPIA</b>   |                           |  |
| 3.3  | Identification Marking & Painting | Painting & Color Code                                 | Minor  | Visual & DFT Measurement | Refer Note 3,8 below & Annexure-1  | Report   | D  | P                 | H   |   |                           |  |
| 3.4  | Packing & End protection          | Marking & Punching<br>Shipping protection             | Major<br>Minor   | Visual<br>Visual         | Refer Note 4,5,8 below<br>Refer Note 6 below & Annexure-2 & 4                                  | HC<br>HC   | D<br>-   | P<br>P            | V<br>V  |   |                           |  |
| 3.5  | Inspection Release Note (IRN)     | Compliance to MQP                                     | Critical   | Compilation (1E+2P)      | Material TCs, Hydrotest, NDE & Dimension and Weight Reports, Form IIIA ( Duly approved by IBR) | IRN  | D  | P                 | H   | 1.IRN to be issued by approved TPIA (As per Annexure-3) (E-Electronic, P-Print copies)<br><br>2.Following documents shall be submitted to TEIL for review & approval of IRN. a) TPIA IRN b) MTCs<br><br>3.After final inspection, TPIA stage wise sign off ITP to be taken and shall be submitted with IRN. |                           |  |
| FOR MANUFACTURER USE:  |                                   |   |  |                          |  | LEGEND:  |  |                   | FOR TPIA USE ( If required):  |   | FOR CUSTOMER USE:         |  |
| <br>Babu Hariharan G, DM/Q&BE   |                                   |   | <br>D.Sandra Priya, DM/Q&BE |                          |  | <br>K.V.Ramani AGM/Q&BE                   |  |                   | M : BHEL / VENDOR;<br>B : BHEL TPIA (from Customer approved TPIA list);<br>H : HOLD POINT (NOT TO PROCEED WITHOUT CLEARANCE)<br>P : PERFORM (100%), V : VERIFY,<br>W : WITNESS (100%), RW : RANDOM WITNESS<br>R : DOCUMENT REVIEW ONLY.<br>D-REPORTS TO BE ESSENTIALLY INCLUDED IN DOCUMENTATION. |   |                           |  |
| PREPARED BY  |                                   |   | REVIEWED BY  |                          |  | APPROVED BY  |  |                   | APPROVED BY (NAME & SEAL)   |   | APPROVED BY (NAME & SEAL) |  |



reviewed

|  |                        | <b>MANUFACTURER'S NAME &amp; ADDRESS</b><br>BHEL PIPING CENTRE, CHENNAI<br>BHEL'S MANUFACTURING SHOPS<br>BHEL / CUSTOMER APPROVED VENDORS |       | <b>MANUFACTURING, INSPECTION AND TESTING QP FOR SUPPLY OF SEAMLESS CARBON STEEL PIPES</b> |                    |   |                   |   |   |         |
|---|------------------------|---|-------|---|--------------------|---|-------------------|---|---|---------|
|   |                        |   |       | <b>SEAMLESS CARBON STEEL PIPES (ASTM A333 GR.6 &amp; ASME SA106 GRB)</b>                  |                    | <b>QP No:</b> 7471:QPC:01<br>REV No: 04<br>DATED 13.10.2021<br><b>MRQ NO.:</b> IBCE-6373-491-PIP-MRQ-AXHA101A |                   | <b>OWNER :</b> IOCL, Barauni<br><b>PROJECT REF :</b> IBCE/158/26882921<br>DATED 16-03-2021<br><b>PMC :</b> TOYO ENGINEERING INDIA PVT. LTD.<br><b>MAIN-SUPPLIER:</b> BHEL-PIPING CENTRE<br><b>BHEL CUSTOMER No:</b> P1 / 7471 |   |         |
| S. No   | COMPONENT & OPERATIONS | CHARACTERISTICS   | CLASS | TYPE OF CHECK   | REFERENCE DOCUMENT | ACCEPTANCE NORMS  | FORMAT OF RECORDS | AGENCY  |   | REMARKS |
| 1   | 2                      | 3   | 4     | 5   | 6                  | 7   | 8                 | M   | B | 10      |

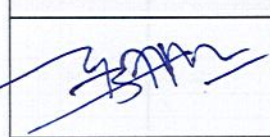
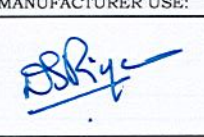
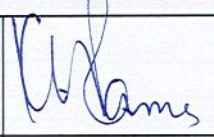

**NOTES**

- For Carbon Steel pipes Carbon content shall be as follows - a) Maximum Carbon Content shall not exceed 0.25%, b) CE shall not exceed 0.43%, when calculated with formula  $CE = \%C + (\%Mn/6)$  and c) CE shall not exceed 0.43%, when calculated with formula  $CE = \%C + (\%Mn/6) + ((\%Cr + \%Mo + \%V)/5) + ((\%Cu + \%Ni)/15)$ .
- If raw material procured from dealer, sample shall be selected from each heat/size for check test and shall be witnessed by BHEL /TPIA. Manufacturing data and records (Mill test reports), Hydro test, Radiographs, results of the other non-destructive examinations and records of dimensional inspection shall be provided by stockiest to purchaser
- Painting :- Rust preventive coating shall be applied on the Machined surfaces. Color Coding - Refer Annexure -1
- Marking :- Paint stencilling at one end: Project name, Work Order, DU details(as per Engg drg) with Spool suffix. Hard Punching at one end: Work Order, Du details, Material spec and size Manufacturer's name or trade mark, Codes or standards (API, ASTM, JIS, JPI, ... etc.), Manufacturing method, Date of manufacture, Manufacturing No. or mark (Charge / Heat No. or lot No.). Stencilling & Punching shall be done in such a manner that any spool may be easily identified without turning or lifting it.
- Marking for pipes including color coding shall be in accordance with the applicable material standard and IBCE-6373-C00-PIP-SPC-000-0008, "Specification for Marking of Piping Material"

|   |   |   |   |  |                              |  |                           |  |
|---|---|---|---|--|------------------------------|--|---------------------------|--|
| FOR MANUFACTURER USE:   |   |   | LEGEND:   |  | FOR TPIA USE ( If required): |  | FOR CUSTOMER USE:         |  |
|  |  |  | M : BHEL / VENDOR;<br>B : BHEL TPIA (from Customer approved TPIA list);<br>H : HOLD POINT (NOT TO PROCEED WITHOUT CLEARANCE)<br>P : PERFORM (100%), V : VERIFY,<br>W : WITNESS (100%), RW : RANDOM WITNESS<br>R : DOCUMENT REVIEW ONLY.<br>D-REPORTS TO BE ESSENTIALLY INCLUDED IN DOCUMENTATION. |  |                              |  |                           |  |
| Babu Hariharan G, DM/Q&BE   | D.Sandra Priya, DM/Q&BE   | K.V.Ramani AGM/Q&BE   |   |  |                              |  |                           |  |
| PREPARED BY   | REVIEWED BY   | APPROVED BY   |   |  | APPROVED BY (NAME & SEAL)    |  | APPROVED BY (NAME & SEAL) |  |

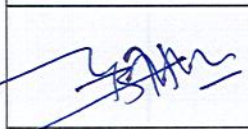

reviewed

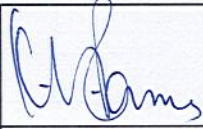
|    |                        | <b>MANUFACTURER'S NAME &amp; ADDRESS</b><br>BHEL PIPING CENTRE, CHENNAI<br>BHEL'S MANUFACTURING SHOPS<br>BHEL / CUSTOMER APPROVED VENDORS |       | <b>MANUFACTURING, INSPECTION AND TESTING QP FOR SUPPLY OF SEAMLESS CARBON STEEL PIPES</b>                  |                    |   |                              |   |                   |         |
|---|------------------------|---|-------|--|--------------------|---|------------------------------|---|-------------------|---------|
|   |                        |   |       | <b>SEAMLESS CARBON STEEL PIPES (ASTM A333 GR.6 &amp; ASME SA106 GRB)</b>                                   |                    | <b>QP No:</b> 7471:QPC:01<br>REV No: 04<br>DATED 13.10.2021<br><b>MRQ NO.:</b> IBCE-6373-491-PIP-MRQ-AXHA101A   |                              | <b>OWNER :</b> IOCL, Barauni<br><b>PROJECT REF :</b> IBCE/158/26882921<br>DATED 16-03-2021<br><b>PMC :</b> TOYO ENGINEERING INDIA PVT. LTD.<br><b>MAIN-SUPPLIER:</b> BHEL-PIPING CENTRE<br><b>BHEL CUSTOMER No:</b> P1 / 7471 |                   |         |
| S. No   | COMPONENT & OPERATIONS | CHARACTERISTICS   | CLASS | TYPE OF CHECK  | REFERENCE DOCUMENT | ACCEPTANCE NORMS  | FORMAT OF RECORDS            | AGENCY  |                   | REMARKS |
|   |                        |   |       |  |                    |   |                              | M   | B                 |         |
| 1   | 2                      | 3   | 4     | 5  | 6                  | 7   | 8                            | 9   | 10                |         |
| <p>6 <b>Items shall be suitably packed to avoid storage &amp; transit damages. Suitable end protectors shall be provided and they shall be properly secured and tightly attached.</b></p> <p>7 Items shall be dry, clean &amp; free from moisture, dirt &amp; loose foreign materials.</p> <p>8 Paint or ink for marking shall not contain any harmful metal or metal salts which can cause corrosive attack either ordinarily or in service.</p> <p>9 For IBR pipes, Original IBR form IIIA to be submitted, visual, dimension, and hydro test witness by TPIA. and IRN issuance by TPIA.</p> <p>10 For "W" &amp; "H" Points - Inspection call to be issued by vendor.</p> <p>11 Above QAP shall be read in conjunction with PO / BHEL Technical Specification / BHEL Drawings.</p> <p>12 Acceptance Norms for all the activities shall be as per PO / PR / STANDARDS referred in the document</p> <p>13 Vendor shall ensure that all Test &amp; Measuring Instruments are duly calibrated by an ISO 17025 accredited lab and calibration shall be valid at the time of inspection. Calibration procedure and records shall be submitted to TEIPL for review</p> |                        |   |       |  |                    |   |                              |   |                   |         |
| FOR MANUFACTURER USE:   |                        |   |       | LEGEND:  |                    |   | FOR TPIA USE ( If required): |   | FOR CUSTOMER USE: |         |
| <br>Babu Hariharan G, DM/Q&BE  |                        | <br>D.Sandra Priya, DM/Q&BE                            |       | <br>K.V.Ramani AGM/Q&BE |                    | M : BHEL / VENDOR;<br>B : BHEL TPIA (from Customer approved TPIA list);<br>H : HOLD POINT (NOT TO PROCEED WITHOUT CLEARANCE)<br>P : PERFORM (100%), V : VERIFY,<br>W : WITNESS (100%), RW : RANDOM WITNESS<br>R : DOCUMENT REVIEW ONLY.<br>D-REPORTS TO BE ESSENTIALLY INCLUDED IN DOCUMENTATION. |                              |   |                   |         |
| PREPARED BY   |                        | REVIEWED BY   |       | APPROVED BY  |                    | APPROVED BY (NAME & SEAL)   |                              | APPROVED BY (NAME & SEAL)   |                   |         |



reviewed



**MANUFACTURER'S NAME & ADDRESS**  
 BHEL PIPING CENTRE, CHENNAI  
 BHEL'S MANUFACTURING SHOPS  
 BHEL / CUSTOMER APPROVED VENDORS

**MANUFACTURING, INSPECTION AND TESTING QP FOR SUPPLY OF SEAMLESS CARBON STEEL PIPES**

**SEAMLESS CARBON STEEL PIPES (ASTM A333 GR.6 & ASME SA106 GRB)**

**QP No:** 7471:QPC:01  
**REV No:** 04  
**DATED:** 13.10.2021  
**MRQ NO.:** IBCE-6373-491-PIP-MRQ-AXHA101A

**OWNER:** IOCL, Barauni  
**PROJECT REF:** IBCE/158/26882921  
**DATED:** 16-03-2021  
**PMC:** TOYO ENGINEERING INDIA PVT. LTD.  
**MAIN-SUPPLIER:** BHEL-PIPING CENTRE  
**BHEL CUSTOMER No:** P1 / 7471



| S. No | COMPONENT & OPERATIONS | CHARACTERISTICS | CLASS | TYPE OF CHECK | REFERENCE DOCUMENT | ACCEPTANCE NORMS | FORMAT OF RECORDS | AGENCY |    | REMARKS |
|-------|------------------------|-----------------|-------|---------------|--------------------|------------------|-------------------|--------|----|---------|
|       |                        |                 |       |               |                    |                  |                   | M      | B  |         |
| 1     | 2                      | 3               | 4     | 5             | 6                  | 7                | 8                 | 9      | 10 |         |

|    |                 |   |  |  |  |  |  |  |  |
|----|-----------------|---|--|--|--|--|--|--|--|
| 14 | HIC requirement | <p>1. The steel for sour service shall be manufactured by either basic oxygen or electric arc furnace route and shall be fully killed and fine grained.</p> <p>2. Carbon steel shall not contain intentional additions of elements such as lead, selenium or sulphur to improve machinability.</p> <p>3. All material after cold forming shall be thermally stress relieved to meet a hardness requirement of 200 BHN maximum.</p> <p>4. Micro structure shall be carried out and all products shall be free of low temperature transformation micro structures such as bainite bands or slets of martensite and shall be certified in report.</p> <p>5. A vendor who has no track record of supplying sour service materials to any of the reputed engineering consultants/operators such as UOP/ IFP/ EXXON/ BP/ CHEVRON/ IOCL/ HPCL/ BPCL/ EIL ,shall be required to carry out HIC test for pre- qualification by any one of the reputed third party inspection agencies like Lloyds, BV, CEIL, DNV or TUV etc..</p> <p>6. HIC test : The requirements for HIC test shall be as follows.<br/>           (i) This test is required for vendor pre-qualification only. (ii) This test shall be performed on a set of three specimens representing each production batch/heat of rolled products in accordance with NACE TM 0284 with the following acceptance criteria:<br/>           (a) Crack Length Ratio (CLR) 10.0%<br/>           (b) Crack Sensitivity Ratio (CSR) &lt; 1%<br/>           (iii) In case of failure of any one of the specimens, three more specimens from the same product shall be retested and all the specimens shall meet the acceptance criteria. In case of failure of any retest sample, the material shall be considered unacceptable.</p> |  |  |  |  |  |  |  |
|----|-----------------|---|--|--|--|--|--|--|--|

| FOR MANUFACTURER USE:     |                         |                     | LEGEND:   | FOR TPIA USE ( If required): | FOR CUSTOMER USE:         |
|---------------------------|-------------------------|---------------------|---|------------------------------|---------------------------|
|                           |                         |                     | M : BHEL / VENDOR;<br>B : BHEL TPIA (from Customer approved TPIA list);<br>H : HOLD POINT (NOT TO PROCEED WITHOUT CLEARANCE)<br>P : PERFORM (100%), V : VERIFY,<br>W : WITNESS (100%), RW : RANDOM WITNESS<br>R : DOCUMENT REVIEW ONLY.<br>D-REPORTS TO BE ESSENTIALLY INCLUDED IN DOCUMENTATION. |                              |                           |
| Babu Hariharan G, DM/Q&BE | D.Sandra Priya, DM/Q&BE | K.V.Ramani AGM/Q&BE |   |                              |                           |
| PREPARED BY               | REVIEWED BY             | APPROVED BY         |   | APPROVED BY (NAME & SEAL)    | APPROVED BY (NAME & SEAL) |

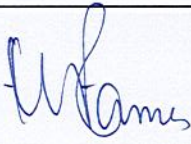

reviewed

|   |                        | <b>MANUFACTURER'S NAME &amp; ADDRESS</b><br>BHEL PIPING CENTRE, CHENNAI<br>BHEL'S MANUFACTURING SHOPS<br>BHEL / CUSTOMER APPROVED VENDORS   |       | <b>MANUFACTURING, INSPECTION AND TESTING QP FOR SUPPLY OF SEAMLESS CARBON STEEL PIPES</b>                     |                    |   |                              |        |                           |         |
|--|------------------------|---|-------|---|--------------------|---|------------------------------|--------|---------------------------|---------|
|  |                        | <b>SEAMLESS CARBON STEEL PIPES (ASTM A333 GR.6 &amp; ASME SA106 GRB)</b>  |       | <b>QP No:</b> 7471:QPC:01<br>REV No: 04<br>DATED 13.10.2021<br><b>MRQ NO.:</b> IBCE-6373-491-PIP-MRQ-AXHA101A |                    | <b>OWNER :</b> IOCL, Barauni<br><b>PROJECT REF :</b> IBCE/158/26882921<br>DATED 16-03-2021<br><b>PMC :</b> TOYO ENGINEERING INDIA PVT. LTD.<br><b>MAIN-SUPPLIER:</b> BHEL-PIPING CENTRE<br><b>BHEL CUSTOMER No:</b> P1 / 7471   |                              |        |                           |         |
| S. No  | COMPONENT & OPERATIONS | CHARACTERISTICS   | CLASS | TYPE OF CHECK   | REFERENCE DOCUMENT | ACCEPTANCE NORMS  | FORMAT OF RECORDS            | AGENCY |                           | REMARKS |
| 1  | 2                      | 3   | 4     | 5   | 6                  | 7   | 8                            | M      | B                         | 10      |
| 15   | Hydrogen Service       | All carbon steel pipes, having wall thickness 9.53mm and above shall be normalized. Cold drawn pipes shall be normalized after the final cold draw pass for all thickness. The normalizing heat treatment shall be a separate heating operation & not a part of the hot forming operation.  |       |   |                    |   |                              |        |                           |         |
| 16   | Galvanising            | For pipes having Galvanizing (GALV) requirement, Pipes Internal and External surfaces shall be galvanized by Hot Dip Galvanizing process in accordance with ASTM A53 at Manufacturer's shop after manufacturing. Galvanized pipes with threaded ends shall be supplied with threads free of galvanized coating. Electroplating process is not acceptable. |       |   |                    |   |                              |        |                           |         |
| FOR MANUFACTURER USE:  |                        |   |       | LEGEND:   |                    |   | FOR TPIA USE ( If required): |        | FOR CUSTOMER USE:         |         |
|  |                        |   |       |                             |                    | M : BHEL / VENDOR;<br>B : BHEL TPIA (from Customer approved TPIA list);<br>H : HOLD POINT (NOT TO PROCEED WITHOUT CLEARANCE)<br>P : PERFORM (100%), V : VERIFY,<br>W : WITNESS (100%), RW : RANDOM WITNESS<br>R : DOCUMENT REVIEW ONLY.<br>D-REPORTS TO BE ESSENTIALLY INCLUDED IN DOCUMENTATION. |                              |        |                           |         |
| Babu Hariharan G, DM/Q&BE  |                        | D.Sandra Priya, DM/Q&BE   |       | K.V.Ramani AGM/Q&BE   |                    |   |                              |        |                           |         |
| PREPARED BY  |                        | REVIEWED BY   |       | APPROVED BY   |                    | APPROVED BY (NAME & SEAL)   |                              |        | APPROVED BY (NAME & SEAL) |         |



**ANNEXURE-1**

**Identification Marks and Colors for Piping Materials**

| Group            | Material               | Pipe                              | Fitting                                |                     | Discrimination Color | Remarks            |
|------------------|------------------------|-----------------------------------|--|---------------------|----------------------|--------------------|
|                  |                        | ASTM Material                     | ASTM Material                          | Identification Mark |                      |                    |
| 1C               | Carbon Steel           | API 5L GR.B PSL 1                 | -                                      | -                   | Yellow               |                    |
|                  |                        | A106 GR.B                         | A234Gr.WPB                             | WPB                 | -                    |                    |
|                  |                        | A106 GR.B                         | A234Gr.WPB                             | WPB                 | Red                  | IBR                |
|                  |                        | -                                 | A234Gr.WPB                             | WPB                 | White                | PWHT               |
|                  |                        | A106 GR.B                         | A234Gr.WPB                             | WPB                 | Orange-Brown         | NACE               |
|                  |                        | A106 GR.B                         | A234Gr.WPB                             | WPB                 | Orange-Pink          | NACE+HIC           |
|                  |                        | A106 GR.B                         | A234Gr.WPB                             | WPB                 | Orange-Yellow        | NACE+HIC+          |
|                  |                        | A106 GR.B                         | A234Gr.WPB                             | WPB                 | Orange-Light Green   | HYDROGEN           |
| 2A               | Al-killed Carbon Steel | A333Gr 6                          | A420Gr.WPL6                            | WPL6                | Silver-Light green   |                    |
|                  |                        | A333Gr 6                          | A420Gr.WPL6                            | WPL6                | Silver-Pink          | NACE+HIC           |
|                  |                        | -                                 | A420Gr.WPL6                            | WPL6                | Silver               | PWHT               |
|                  |                        | A671GR.CC60 CL 12                 | -                                      | -                   | Light green          |                    |
|                  |                        | A671GR.CC60 CL 12-S2              | -                                      | -                   | -                    |                    |
|                  |                        | A671GR.CC60 CL 13                 | -                                      | -                   | Silver-Light green   |                    |
|                  |                        | A671GR.CC60 CL 22                 | -                                      | -                   | White                |                    |
|                  |                        | A671GR.CC60 CL 22-S2              | -                                      | -                   | White-Light green    |                    |
|                  |                        | A333Gr.6 / A106GR.B-Impact Tested | A420Gr.WPL6 / A234GR.WPB-Impact Tested | WPL6 / WPB          | Silver-Red           | IBR                |
|                  |                        | A671GR.CC60CL.12                  | -                                      | -                   | Red                  | IBR                |
|                  |                        | A671GR.CC60 CL.22-S2              | A234GR.WPB,PWHT, Impact Tested         | WPB                 | White-Red            | IBR                |
|                  |                        | A671GR.CC60 CL 22                 | A234GR.WPB,PWHT                        | WPB                 | Light green-Red      | IBR                |
|                  |                        | A671GR.CC60 CL 32                 | A234Gr.WPB                             | WPB                 | Brown                |                    |
|                  |                        | A672GR.B60 CL.12/22               | A234Gr.WPB                             | WPB                 | Purple               | NORMAL+ 200BHN MAX |
|                  |                        | A672GR.B60 CL 12                  | A234Gr.WPB                             | WPB                 | Purple-Red           | IBR                |
| A672GR.B60 CL.32 | A234Gr.WPB             | WPB                               | Pink-Yellow                            | NACE+HIC+           |                      |                    |
| A672GR.B60 CL.22 | A234Gr.WPB             | WPB                               | Pink                                   | PWHT                |                      |                    |
| A672GR.B60 CL.22 | A234Gr.WPB             | WPB                               | Pink+White                             | PWHT+ NACE          |                      |                    |



reviewed

**ANNEXURE-2**

(a) One color

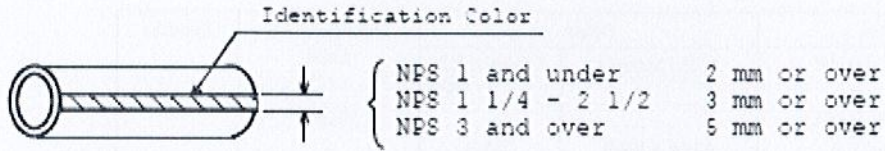

(b) Two colors

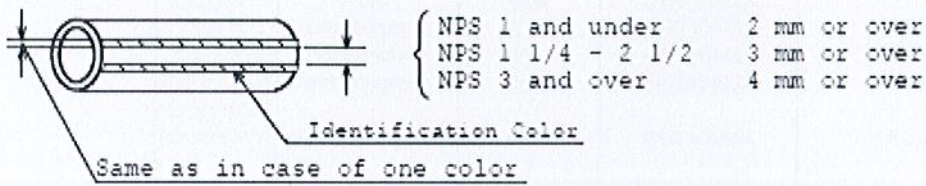

**Painting of Identification Color**

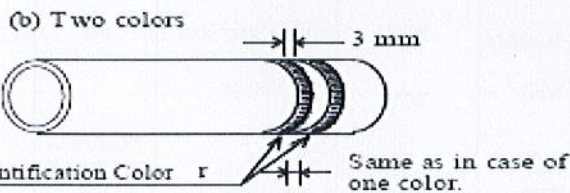
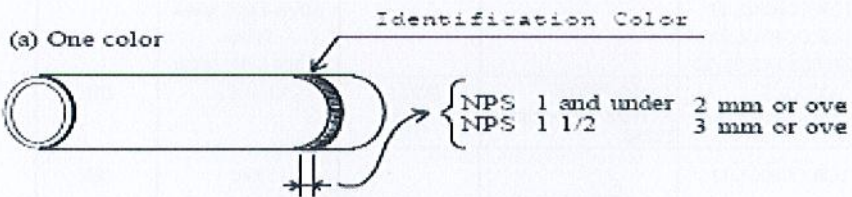

**Painting of Identification Color (NPS 1 1/2 and smaller only)**



### Annexure-3

Approved TPIA vendor list below

1. M/s TUV SUD South Asia Pvt. Ltd
2. M/s VCS Quality Services Private Limited.
3. M/s IR Class System and Solutions Private Limited
4. M/s Project & Development India Ltd. (PDIL)
5. M/s. Tata Projects Limited
6. M/s Certification Engineers International Limited
7. M/s Bureau Veritas (India) Pvt. Ltd.
8. M/s. ABS Industrial Verification(India) Pvt.Ltd

Page 13 of 14



reviewed

### Annexure-4

| KIND OF EQUIPMENT | INNER PACKAGE   | OUTER PACKAGE   | NOTES  | MODE OF TRANSPORTATION   |
|-------------------|---|---|--|--------------------------|
| Pipes             | 1. When the crate or box shall be adopted, heavy-duty water-pro | . Both ends and center of pipes shall be bundled with steel band after setting the lumber as hurdle type on the pipe.<br>2. Box or crate shall be applied to stainless steel and galvanize pipe.<br>3. Carbon steel pipe and alloy steel pipe shall be packed as follows:<br>a) Under 35mm in diameter -<br>Crate<br>b) Over 35mm to 150mm in diameter -<br>Bundle<br>c) Over 150mm in diameter -Bare | As a rule, the prefabricated pipes shall be packed by crate.<br>Inserting smaller pipe into other pipe shall be prohibited.<br>In order to protect the end face, polyethylene cap shall be put and fixed adhesive tape.<br>Both ends of pipe having over 350mm in diameter shall be protected from deforming by crossed wooden bars. | Conventional Vessel (CV) |



reviewed

ALL DIMENSIONS ARE IN MILLIMETRES

CAUTION: The information on this document is the property of BHARAT HEAVY ELECTRICALS LTD. It must not be used directly or indirectly in any way detrimental to the interest of the company.

|                           |                  |   |                         |                  |  |
|---------------------------|------------------|---|-------------------------|------------------|--|
| REV<br>01                 | DATE<br>16.08.21 | ALTERED: K.SAHITHYA<br>CHD & APPD: I.D.B.RAJU | REV<br>02               | DATE<br>11.04.22 | ALTERED : K.SAHITHYA<br>APPROVED: I.D.B.RAJU |
| ITEM DESCRIPTION CHANGED. |                  |   | EP DESCRIPTION CHANGED. |                  |  |
| REVISIONS ARE MARKED AS   |                  |   | REVISIONS ARE MARKED AS |                  |  |

**NOTES: -**

- 01 FOLLOW APPLICABLE QP & TDG FOR THE PROJECT.
- 02 PIPES (ITEM Nos. 03,05,06) SHALL BE SUPPLIED WITH EDGE PREPARED.



**FIG 2(A)**

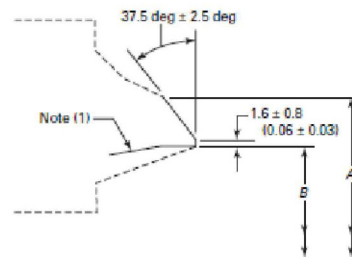

- NOTES:  
 (1) Internal surface may be as-formed or machined for dimension  $\phi$  at root face. Contour within the envelope shall be in accordance with section 2.  
 (2) Intersections should be slightly rounded.

| SL No. | PIPE DESCRIPTION                                    | SPECIFIC LENGTH | MATL CODE       |            | EDGE PREPARATION      |          | QTY (M) |
|--------|---|-----------------|-----------------|------------|-----------------------|----------|---------|
|        |   |                 | MATL SPEC.      |            | STYLE                 | B, in mm |         |
| 01     | PIPE OD33.4x4.55 - SA106GRB                         | 4 MTR TO 6 MTR  | 15 182 011 0000 | SA 106 GRB | -                     | -        | 15      |
| 02     | PIPE OD48.3x5.08 - SA106GRB                         | 4 MTR TO 6 MTR  | 15 182 021 0000 | SA 106 GRB | -                     | -        | 6       |
| 03     | PIPE OD60.3x8.74 - SA106GRB                         | 4 MTR TO 6 MTR  | 15 182 031 0000 | SA 106 GRB | FIG2(A) AS PER B16.25 | 43       | 6       |
| 04     | PIPE OD21.3x4.78 - SA106GRB                         | 4 MTR TO 6 MTR  | 15 182 003 0000 | SA 106 GRB | -                     | -        | 162     |
| 05     | PIPE OD114.3X6.02 -SA106GRB                         | 4 MTR TO 6 MTR  | 15 182 090 0000 | SA 106 GRB | FIG2(A) AS PER B16.25 | 102      | 6       |
| 06     | PIPE OD219.1x8.18 -SA106GRB                         | 4 MTR TO 6 MTR  | 15 082 099 0000 | SA 106 GRB | FIG2(A) AS PER B16.25 | 203      | 12      |
| 07     | PIPE OD88.9X5.49 - SA106GRB (GALVANIZED & THREADED) | 4 MTR TO 6 MTR  | 15 182 138 0000 | SA 106 GRB | -                     | -        | 66      |

|  |  |  |                |                   |                                      |          |                  |
|--|--|--|----------------|-------------------|--------------------------------------|----------|------------------|
|  | BHARAT HEAVY ELECTRICALS LIMITED<br>PIPING CENTRE<br>CHENNAI 600 017 |  | DRN            | NAME              | SIGN                                 | DATE     | NO. OF VAR       |
|  |  |  | CHD            | I.D.B.RAJU        |                                      | 30.06.21 |                  |
|  |  |  | APPD           | SARAVANAN.C       |                                      | 30.06.21 |                  |
| DEPT CODE  | GRADE OF UNTOL.DIM<br>C / M / F                                      |  | SCALE<br>N.T.S | WEIGHT (KG).      | REF. TO ASSY./OLD DRG.               | ITEM NO. | NO. OF ITEMS     |
| TITLE<br><b>PRODUCTION NOTES<br/>SEEMLESS PIPES (CS)</b> |  |  |                | CARD CODE<br>U 01 | DRAWING NO.<br><b>4-80-998-84399</b> |          | REV<br><b>02</b> |

Size A4

CAUTION: The information on this document is the property of BHARAT HEAVY ELECTRICALS LTD. It must not be used directly or indirectly in any way detrimental to the interest of the company.

ALL DIMENSIONS ARE IN MILLIMETRES

|                         |                  |   |           |      |                        |
|-------------------------|------------------|---|-----------|------|------------------------|
| REV<br>01               | DATE<br>11.04.22 | ALTERED: K.SAHITHYA<br>CHD & APPD: I.D.B.RAJU | REV<br>02 | DATE | ALTERED :<br>APPROVED: |
| EP DESCRIPTION CHANGED. |                  |   |           |      |                        |
| REVISIONS ARE MARKED AS |                  |   |           |      |                        |

**NOTES: -**

- 01 METHOD OF MANUFACTURE, PWHT, FERRITE NO. TEST, IMPACT TEST, HARDNESS TEST SHALL BE AS PER TECHNICAL SPEC OF THE PROJECT.
- 02 PIPES SHALL FOLLOW APPENDIX-5 OF SPECIAL SERVICE REQUIREMENTS OF TECHNICAL SPEC. OF THE PROJECT.
- 03 FOLLOW APPLICABLE QP & TDG FOR THE PROJECT.
- 04 PIPES SHALL BE SUPPLIED WITH EDGE PREPARED.



**FIG 2(A)**

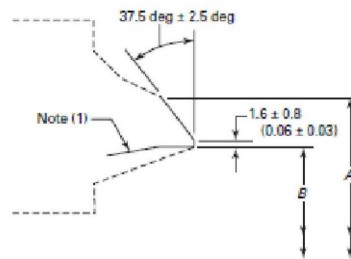

- NOTES:  
 (1) Internal surface may be as-formed or machined for dimension B at root face. Contour within the envelope shall be in accordance with section 2.  
 (2) Intersections should be slightly rounded.



| SL No. | PIPE DESCRIPTION                                 | SPECIFIC LENGTH | MATL CODE<br>MATL SPEC.       | EDGE PREPARATION      |          | QTY<br>(M) |
|--------|--|-----------------|-------------------------------|-----------------------|----------|------------|
|        |  |                 |                               | STYLE                 | B, in mm |            |
| 01     | PIPE OD26.7x5.56 - SA106GRB<br>HIC NACE HYDROGEN | 4 MTR TO 6 MTR  | 15 182 008 0000<br>SA 106 GRB | -                     | -        | 6          |
| 02     | PIPE OD26.7x5.56 - SA106GRB<br>HIC NACE          | 4 MTR TO 6 MTR  | 15 182 008 0000<br>SA 106 GRB | -                     | -        | 36         |
| 03     | PIPE OD26.7x5.56 - SA106GRB<br>NACE              | 4 MTR TO 6 MTR  | 15 182 008 0000<br>SA 106 GRB | -                     | -        | 93         |
| 04     | PIPE OD26.7x5.56 - SA106GRB<br>HYDROGEN          | 4 MTR TO 6 MTR  | 15 182 008 0000<br>SA 106 GRB | -                     | -        | 36         |
| 05     | PIPE OD60.3x8.74 - SA106GRB<br>NACE              | 4 MTR TO 6 MTR  | 15 182 031 0000<br>SA 106 GRB | FIG2(A) AS PER B16.25 | 43       | 12         |
| 06     | PIPE OD114.3x6.02 - SA106GRB<br>HYDROGEN         | 4 MTR TO 6 MTR  | 15 182 090 0000<br>SA 106 GRB | FIG2(A) AS PER B16.25 | 102      | 6          |
| 07     | PIPE OD219.1x8.18 - SA106GRB<br>HYDROGEN         | 4 MTR TO 6 MTR  | 15 082 099 0000<br>SA 106 GRB | FIG2(A) AS PER B16.25 | 203      | 12         |

|   |   |  |                |                      |                                      |                  |                  |
|---|---|--|----------------|----------------------|--------------------------------------|------------------|------------------|
|   | <b>BHARAT HEAVY ELECTRICALS LIMITED</b> |  | DRN            | NAME<br>K.SAHITHYA   | SIGN                                 | DATE<br>05.07.21 | NO. OF<br>VAR    |
|   | PIPING CENTRE<br>CHENNAI 600 017        |  | CHD            | I.D.B.RAJU           |                                      | 05.07.21         |                  |
|   |   |  | APPD           | SARAVANAN.C          |                                      | 05.07.21         |                  |
| DEPT<br>CODE  | GRADE OF<br>UNTOL.DIM<br>C / M / F      |  | SCALE<br>N.T.S | WEIGHT (KG).         | REF. TO ASSY./OLD DRG.               | ITEM NO.         | NO. OF<br>ITEMS  |
| TITLE<br><b>PRODUCTION NOTES OF<br/>SPL SERVICE REQUIREMENT PIPES</b> |   |  |                | CARD<br>CODE<br>U 01 | DRAWING NO.<br><b>4-80-998-84402</b> |                  | REV<br><b>01</b> |

Size A4

ALL DIMENSIONS ARE IN MILLIMETRES

CAUTION: The information on this document is the property of BHARAT HEAVY ELECTRICALS LTD. It must not be used directly or indirectly in any way detrimental to the interest of the company.

|   |                  |   |   |                  |  |
|---|------------------|---|---|------------------|--|
| REV<br>01   | DATE<br>16.08.21 | ALTERED: K.SAHITHYA<br>CHD & APPD: I.D.B.RAJU | REV<br>02   | DATE<br>11.04.22 | ALTERED : K.SAHITHYA<br>APPROVED: I.D.B.RAJU |
| QTY REVISED.<br>ITEM DESCRIPTION CHANGED.   |                  |   | EP DESCRIPTION CHANGED.   |                  |  |
| REVISIONS ARE MARKED AS  |                  |   | REVISIONS ARE MARKED AS  |                  |  |

**NOTES: -**



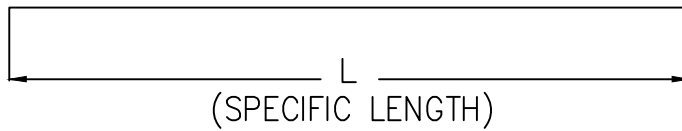

- 01 FOLLOW APPLICABLE QP & TDG FOR THE PROJECT.
- 02 PIPES (ITEM NOS. 02-03) SHALL BE SUPPLIED WITH EDGE PREPARED.

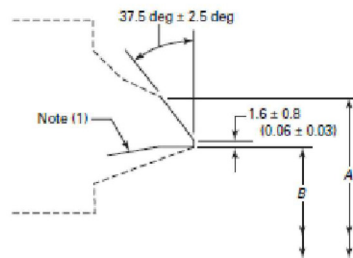
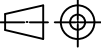

**FIG 2(A)**



- NOTES:  
 (1) Internal surface may be as-formed or machined for dimension  $\phi$  at root face. Contour within the envelope shall be in accordance with section 2.  
 (2) Intersections should be slightly rounded.

| SL. No.   | PIPE DESCRIPTION  | SPECIFIC LENGTH | MATL. CODE<br>MATL. SPEC.      | EDGE PREPARATION      |          | QTY (M) |
|---|---|-----------------|--------------------------------|-----------------------|----------|---------|
|   |   |                 |                                | STYLE                 | B, in mm |         |
| 01  | PIPE OD26.7X5.56 - SA333GR.6                              | 4 MTR TO 6 MTR  | 15 498 012 0000<br>SA 333 GR.6 | -                     | -        | 48      |
|   | 02 PIPE OD88.9X5.49 - SA333GR.6<br>HIC NACE               | 4 MTR TO 6 MTR  | 15 498 016 6000<br>SA 333 GR.6 | FIG2(A) AS PER B16.25 | 78       | 6       |
|   | 03 PIPE OD114.3X6.02 - SA333GR.6                          | 4 MTR TO 6 MTR  | 15 498 017 6000<br>SA 333 GR.6 | FIG2(A) AS PER B16.25 | 102      | 21      |
|    | 04 PIPE OD26.7X5.56 - SA106GRB<br>(GALVANIZED & THREADED) | 4 MTR TO 6 MTR  | 15 182 008 0000<br>SA 106 GRB  | -                     | -        | 33      |

|   |                                    |   |                |                      |                                      |          |                  |               |
|---|------------------------------------|---|----------------|----------------------|--------------------------------------|----------|------------------|---------------|
|  |                                    | <b>BHARAT HEAVY ELECTRICALS LIMITED</b><br>PIPING CENTRE<br>CHENNAI 600 017         |                | DRN                  | NAME<br>K.SAHITHYA                   | SIGN     | DATE<br>26.07.21 | NO. OF<br>VAR |
|   |                                    |   |                | CHD                  | I.D.B.RAJU                           |          | 26.07.21         |               |
|   |                                    |   |                | APPD                 | SARAVANAN.C                          |          | 26.07.21         |               |
| DEPT<br>CODE  | GRADE OF<br>UNTOL.DIM<br>C / M / F |  | SCALE<br>N.T.S | WEIGHT (KG).         | REF. TO ASSY./OLD DRG.               | ITEM NO. | NO. OF<br>ITEMS  |               |
| TITLE<br><b>PRODUCTION NOTES<br/>SEAMLESS PIPES (CS)</b>                            |                                    |   |                | CARD<br>CODE<br>U 01 | DRAWING NO.<br><b>4-80-998-84415</b> |          | REV<br><b>02</b> |               |

Size A4

|  |                                     |   |  |  |  |
|--|-------------------------------------|---|--|--|--|
| <br><b>TOYO ENGINEERING</b><br><b>INDIA PVT. LTD.</b> | <b>APPENDIX-5</b>                   |   |  |  | <b>JOB NO. : 6373</b><br><b>REQ NO. : AXHA101A</b><br><br><b>PAGE 1 OF 6</b> |
|  | <b>SPECIAL SERVICE REQUIREMENTS</b> |   |  |  |  |
|  | <b>REV. MARK</b>                    | 0 |  |  |  |
| <b>ISSUE DATE</b>  | 31-Aug-2020                         |   |  |  |  |

## 1.0 SCOPE

- 1.1 These requirements are applicable for Pipe, Valves, Flanges, Fittings used in Special Services marked in individual BOQ description such as "Hydrogen, NACE, HIC, IBR" etc. These are in addition to the requirements described in "Appendix-2, Appendix-3 and shall be read in conjunction with this specification.

## 2.0 HYDROGEN SERVICE

### 2.1 PIPES, FITTINGS, FLANGES & VALVES

#### 2.1.1 METHOD OF MANUFACTURE

All carbon steel pipes, fittings & flanges having wall thickness 9.53mm and above shall be normalized. Cold drawn pipes & fittings shall be normalized after the final cold draw pass for all thickness. In addition, fittings made from forgings shall have carbon - 0.35% maximum and silicon -0.35% maximum. The normalizing heat treatment shall be a separate heating operation & not a part of the hot forming operation.

All alloy steel (Cr-Mo) pipes, forgings & fittings shall be normalized and tempered. The normalizing and tempering shall be a separate heating operation and not a part of the hot forming operation. The maximum room temperature tensile strength shall be 100,000 psi.

#### 2.1.2 POST WELD HEAT TREATMENT (PWHT)

All carbon steel pipes & fittings post weld heat-treatment shall be carried out as per table 331.1.1, 331.1.2 & 331.1.3 of ASME B31.3 2016 edition.

All alloy steel (Cr-Mo) pipes & fittings shall be post weld heat treated irrespective of type or thickness of weld. 100% radiography of welded joints shall be done both before and after PWHT.

All austenitic SS grades shall be solution annealed after welding.

#### 2.1.3 FERRITE NO. TEST

For all austenitic stainless steels, the weld deposit shall be checked for ferrite content. A Ferrite No. (FN) not less than 3% and not more than 10% is required to avoid sigma phase embitterment during heat treatment. FN shall be determined by Ferrite scope prior to post weld heat treatment.

#### 2.1.4 IMPACT TEST

For carbon steel and alloy steels pipes, fittings & flanges of thickness over 19mm, Charpy-V notch impact testing shall be carried out in accordance with paragraph UG-84 of ASME Section VIII, Div-1 for weld metal and base metal from the thickest item per heat of material and per heat treating batch.

Impact test specimen shall be in complete heat treated condition and in accordance with ASTM A370. Impact energies at 0°C shall average greater than 27J (20 ft-lb) per set of three specimens, with a minimum of 19J (15 ft-lb).

If welding is used in manufacturing, impact test of Heat Affected Zone (HAZ) and weld metal shall also be carried out.

#### 2.1.5 HARDNESS

For carbon steel pipes & fittings, hardness of weld and HAZ shall be limited to 200 BHN (max.).

For alloy steel pipes & fittings, hardness of weld and HAZ shall be limited to 225 BHN (max.).

|  |                                     |   |  |  |  |
|--|-------------------------------------|---|--|--|--|
| <br><b>TOYO ENGINEERING</b><br><b>INDIA PVT. LTD.</b> | <b>APPENDIX-5</b>                   |   |  |  | <b>JOB NO. : 6373</b><br><b>REQ NO. : AXHA101A</b><br><br><b>PAGE 2 OF 6</b> |
|  | <b>SPECIAL SERVICE REQUIREMENTS</b> |   |  |  |  |
|  | <b>REV. MARK</b>                    | 0 |  |  |  |
| <b>ISSUE DATE</b>  | 31-Aug-2020                         |   |  |  |  |

### 2.1.6 RADIOGRAPHY

All girth welded joints (longitudinal & circumferential) shall be 100% radiographed in accordance with UW-51 of ASME Section VIII, Div-1 and ASME Section V.

### 2.2 VALVES

2.2.1 All valve castings shall be of radiographic quality.

2.2.2 All cast valve flanges and bodies of rating class 900 or greater shall be examined in accordance with paragraph 7.2 through 7.5 of Appendix 7 of ASME Section VIII, Div-1, regardless of casting quality factor.

2.2.3 Only normalized and tempered material shall be used in the following specifications:

Casting : A217Gr.WC1, A217Gr.WC4, A217Gr.WC5, A217Gr.WC6, A217Gr.WC9, A217Gr.C5, A217Gr.C12.

Forging : A182 Gr.F11 CL.2, A182 Gr.F22 CL.3, A182 Gr.F5, A182 Gr.F9

2.2.4 Body/ bonnet/ cover joints & stuffing box of valves shall have low emission. One valve per metallurgy, per rating, per size shall be helium leak tested as per ASME Section V, Subsection A, article 10 (Detector probe technique), Appendix IV at a minimum of 25% of the allowable (rated) cold working pressure. Selection of valves for helium leak test shall be at random. Test duration shall be as follows:-

| Nominal size | Test Duration in minutes |     |           |      |      |
|--------------|--------------------------|-----|-----------|------|------|
|              | Pressure class           |     |           |      |      |
|              | Up to 300                | 600 | 800 & 900 | 1500 | 2500 |
| Up to 2"     | 3                        | 6   | 9         | 12   | 12   |
| 3" to 6"     | 6                        | 9   | 12        | 15   | 18   |
| 8" to 16"    | 9                        | 9   | 12        | 15   | 18   |
| 18" to 24"   | 9                        | 12  | 15        | 18   | 21   |

The valve shall show no leakage. No leakage is defined as total leakage rate of less than 0.0001 ml/s of helium.

### 2.3 C.S. & A.S. VALVES

Bend test and magnetic particle inspection of the entire surface of body and bonnet casting shall be in accordance with ASTM A217. Supplementary requirement S3 & S4 evaluation of magnetic particle inspection shall be in accordance with MSS-SP-53 except that no linear discontinuities shall be allowed.

The Brinell hardness of heat-treated casting shall not exceed 200 BHN for carbon steel & 225 for alloy steel.

Repair of defective casting shall be outlined in writing to the purchaser before repair starts. Repair method to be approved prior to welding.

Casting shall be preheated to a minimum of 400°F prior to welding and all chromium molybdenum alloys shall be post weld heat treated after welding is complete. Stress relieving is essential for welds.

Carbon steel shall be normalized and alloy steel shall be normalized and tempered. Dye penetrant test of welds shall be in accordance with ASTM E165 Procedure B-2.

Interpretation as per Appendix-8 of ASME-VIII Div.1.

The tensile stress for AS shall be less than 100,000 psi.

|  |                                     |   |  |  |  |
|--|-------------------------------------|---|--|--|--|
| <br><b>TOYO ENGINEERING</b><br><b>INDIA PVT. LTD.</b> | <b>APPENDIX-5</b>                   |   |  |  | <b>JOB NO. : 6373</b><br><b>REQ NO. : AXHA101A</b><br><br><b>PAGE 3 OF 6</b> |
|  | <b>SPECIAL SERVICE REQUIREMENTS</b> |   |  |  |  |
|  | <b>REV. MARK</b>                    | 0 |  |  |  |
| <b>ISSUE DATE</b>  | 31-Aug-2020                         |   |  |  |  |

Charpy V-notch impact testing is to be done for valve material (average 20 ft-lb for set of 3 (min. value 15 ft-lb) at 30°F).

For radiography and acceptance criteria for valve casting refer Clause 7.6.

## 2.4 S. S. VALVES

Casting and test bar shall be heat treated together. Valve casting shall be in the solution heat treated and pickled condition.

Critical body and bonnet casing section typically defined by ASME B16.34 shall be radiographed and shall meet the requirement of ASTM E446 (up to 2" thick) category A, B & CA Level 2, category CB, OC & CD Level 3, category D, B & F Level 0. For wall thickness 2" to 4.5" comparable plates of ASTM E186 shall be used. ASTM E94 & ASTM E142 shall be used for recommended practice & controlling quality of radiography as a guide. The entire surface of all casting shall be dye-penetrant inspected after pickling.

Repair welds shall be 100% radiographed and evaluated in accordance with paragraph 344.5 of ASME B31.3 with a minimum casting quality factor of 0.95. Dye-penetration Test shall be as per ASTM E-165 Procedure B-2, Interpretation as per Appendix 8 of ASME VIII Div 1.

## 3.0 IBR (INDIAN BOILER REGULATIONS)

- 3.1 IBR stands for Indian Boiler Regulation. For steam services, it is statutory obligation to meet IBR requirements. For items under IBR, composition restrictions, test reports, painting, etc. shall be as per IBR's stipulations.
- 3.2 All items under purview of 'IBR' (Indian Boiler Regulations) shall be accompanied with IBR certificate original in Form III A for pipes and IIIC for other piping items, duly approved by IBR Authority/Local Authority empowered by Central Board of India. Alternatively, photocopy of original certificate duly countersigned and attested by Local Boiler Inspection, is the minimum requirement.
- 3.3 In carbon steel piping, carbon content shall not exceed 0.25% for all Pipes, fittings, flanges & valve bodies, etc. that may require welding. Moreover, for flanges the sulphur and phosphorus also shall be limited to 0.05% each.

## 4.0 IMPACT TESTS

Welded pipes and fittings used below ASME temp. -29 Deg.C. shall be impact tested as per requirement of ASME B31.3.

## 5.0 MATERIAL REQUIREMENT FOR CARBON STEEL COMPONENTS USED IN SOUR SERVICE

### 5.1 SCOPE

In general, for refinery services, NACE Standard MR0103 shall be applicable. For services where HIC (Hydrogen Induced Cracking) resistant carbon steel is specifically mentioned in the Process Documents, this specification shall be followed.

- 5.1.1 This specification lays down the requirements related to the chemical composition, manufacture, fabrication and testing requirements for carbon steel components intended to be used in sour service in petroleum refinery environments. These requirements are specified in order to make the carbon steel component resistant to the various forms of material damage in a sour environment, such as Sulfide Stress Cracking (SSC), Hydrogen Induced Cracking (HIC), Stress Oriented Hydrogen Induced

|  |                                     |   |  |  |  |
|--|-------------------------------------|---|--|--|--|
| <br><b>TOYO ENGINEERING</b><br><b>INDIA PVT. LTD.</b> | <b>APPENDIX-5</b>                   |   |  |  | <b>JOB NO. : 6373</b><br><b>REQ NO. : AXHA101A</b><br><br><b>PAGE 4 OF 6</b> |
|  | <b>SPECIAL SERVICE REQUIREMENTS</b> |   |  |  |  |
|  | <b>REV. MARK</b>                    | 0 |  |  |  |
| <b>ISSUE DATE</b>  | 31-Aug-2020                         |   |  |  |  |

Cracking (SOHIC), Blistering etc. These requirements can be used for resisting Alkaline Stress Corrosion Cracking (ASCC) also. This specification is applicable for corrosive petroleum refining facilities.

- 5.1.2** The service medium is defined as “Sour” when the service environment conforms to one of the following conditions, as defined in NACE Standard MR0103.

Service environments containing free water (in liquid phase) and:

- (a) >50 ppmw dissolved H<sub>2</sub>S in the free water.
- (b) Free water pH < 4 and some dissolved HTS present.
- (c) Free water pH >7.6 and 20 ppmw dissolved hydrogen cyanide (HCN) in the water and some dissolved HTS present.
- (d) >0.003 MPa absolute (0.05 psia) partial pressure H<sub>2</sub>S in the gas in processes with a gas phase.

## 5.2 REFERENCE CODES AND STANDARDS

|                                |            |                     |
|--------------------------------|------------|---------------------|
| NACE MR 0103                   | ASTM A 694 | ASTM A 770          |
| NACE RP 0472                   | ASTM A 216 | ASTM A 370          |
| NACE Publication 8X194 & 8X294 | ASTM A 106 | ASTM A 578          |
| NACE TM 0284                   | API 5 L    | ASME SEC II PART C  |
| ASTM A 20                      | API 6 A    | ASME SEC VIII-DIV.I |
| ASTM A 516                     | ASTM E 18  | ASME SEC IX         |
| ASTM A 105                     | ASTM E 45  | ANSI B 16.34        |
| ASTM A 234                     | ASTM E 92  | ANSI B 31.3         |

All ASTM Standard designations shall be applicable for corresponding ASME designations which would be read as ASME SA XXX instead of ASTM A XXX.

## 5.3 GENERAL REQUIREMENT

- 5.3.1** The steel for sour service shall be manufactured by either basic oxygen or electric arc furnace route and shall be fully killed and fine grained.
- 5.3.2** Carbon steel shall not contain intentional additions of elements such as lead, selenium or sulphur to improve machinability.
- 5.3.3** Carbon steel shall be used in one of the following heat treatment conditions.
- (i) Hot-rolled
  - (ii) Annealed
  - (iii) Normalized
  - (iv) Normalized and tempered
  - (v) Normalized, austenitised, quenched and tempered
  - (vi) Austenitised, quenched and tempered
- 5.3.4** All material after cold forming shall be thermally stress relieved to meet a hardness requirement of 200 BHN maximum.
- 5.3.5** All products shall be free of low temperature transformation microstructures such as bainite bands or islets of martensite.

|  |                                     |   |  |  |  |
|--|-------------------------------------|---|--|--|--|
| <br><b>TOYO ENGINEERING</b><br><b>INDIA PVT. LTD.</b> | <b>APPENDIX-5</b>                   |   |  |  | <b>JOB NO. : 6373</b><br><b>REQ NO. : AXHA101A</b><br><br><b>PAGE 5 OF 6</b> |
|  | <b>SPECIAL SERVICE REQUIREMENTS</b> |   |  |  |  |
|  | <b>REV. MARK</b>                    | 0 |  |  |  |
| <b>ISSUE DATE</b>  | 31-Aug-2020                         |   |  |  |  |

#### 5.4 MATERIAL SPECIFICATION

All items are required to conform to the chemical composition of the respective specification as listed below.

Plate: SA-516 Gr.60

Pipe: SA-106 Gr. B or SA-333 Gr.1 or 6

Forgings: SA-105 or SA-350 Gr.LF1 or LF2 or SA-266 Class-I

Fittings: SA-234 Gr. WCB or SA-420 Gr.WPL6

Castings: SA-216 Gr. WCA, WCB or WCC or SA-352 Gr. LCA, LCB or LCC

Tubing: SA-179 or SA-214

#### 5.5 PRODUCT SPECIFIC REQUIREMENTS

##### 5.5.1 Plates and rolled products

All rolled products such as plates and sheets and fittings / pipes made of rolled products shall meet the following specific requirements.

- 5.5.1.1 The steel shall be made through a clean steel making route and shall have minimum of inclusions.
- 5.5.1.2 The sulphur level shall be restricted to 0.003 wt%.
- 5.5.1.3 The steel shall be calcium treated for inclusion morphology control and the Ca/S ratio shall be in the range of 2 to 3. When sulphur content is less than 0.0015%, then Ca/S ratio is not applicable and calcium can be present up to 50 ppm.
- 5.5.1.4 For plates including and above 25 mm thick, through-thickness tensile testing shall be carried out in accordance with ASTM A770, with minimum reduction in area being 35% as determined in accordance with ASTM A370, on one plate per heat.
- 5.5.1.5 No repair welding shall be permitted on plated.
- 5.5.1.6 When the fabrication of the components from the previously HIC tested plates involves no heavy wall thickness reduction or material flow, such as bending, spinning or welding, no fresh HIC test would be required on the final product. However, for fabrication of products where heavy reduction of thickness and heavy flow of material is encountered while forming such as like forging, extrusion or drawing, metallographic examination of the final product shall be required to be carried out to ensure absence of elongated inclusions.
- 5.5.1.7 The plates shall be procured only from pre-qualified manufacturers.

##### 5.5.2 Pre-qualification criteria for vendors with prior experience track record

Vendors/manufacturers who have proven track record of supplying materials for sour service applications in petroleum refineries to any of the reputed operating companies/Engineering Consultants or Process Licensors such as UOP/ IFP/ EXXON/ BP/ CHEVRON/ IOCL/ HPCL/ BPCL/ EIL will be considered as 'pre-qualified vendors/manufacturers', on production of the relevant Purchase Orders and test certificates, certified by a witnessing third party inspection agency such as DNV/Lloyds/BV/ABSTECH/TUV/SGS/CEIL for the conformance of the materials to the respective materials specification of the mentioned operators / engineering consultants. For pre-qualified vendors, Clause No.4.5.4 is not applicable.

|  |                                     |   |  |  |  |  |
|--|-------------------------------------|---|--|--|--|--|
| <br><b>TOYO ENGINEERING</b><br><b>INDIA PVT. LTD.</b> | <b>APPENDIX-5</b>                   |   |  |  |  | <b>JOB NO. : 6373</b><br><b>REQ NO. : AXHA101A</b><br><br><b>PAGE 6 OF 6</b> |
|  | <b>SPECIAL SERVICE REQUIREMENTS</b> |   |  |  |  |  |
|  | <b>REV. MARK</b>                    | 0 |  |  |  |  |
| <b>ISSUE DATE</b>  | 31-Aug-2020                         |   |  |  |  |  |

### 5.5.3 Pre-qualification criteria for New Vendors without track record

A vendor who has no track record of supplying sour service materials to any of the reputed engineering consultants/operators, as mentioned in Clause 4.5.2 above, shall be considered as a new vendor and shall be required to carry out HIC test as detailed out in Clause 4.5.4 for pre- qualification by any one of the reputed third party inspection agencies like Lloyds, BV, CEIL, DNV or TUV etc..

### 5.5.4 Hydrogen Induced Cracking (HIC) Test

The requirements for HIC test shall be as follows.

- (i) This test is required for vendor pre-qualification only.
- (ii) This test shall be performed on a set of three specimens representing each production batch/heat of rolled products in accordance with NACE TM 0284 with the following acceptance criteria:
  - (a) Crack Length Ratio (CLR) 10.0%
  - (b) Crack Sensitivity Ratio (CSR) < 1%
- (iii) In case of failure of any one of the specimens, three more specimens from the same product shall be retested and all the specimens shall meet the acceptance criteria. In case of failure of any retest sample, the material shall be considered unacceptable.

### 5.6 POST WELD HEAT TREATMENT (PWHT) AND HARDNESS REQUIREMENT

All the weld joints, irrespective of thickness, shall be given a post weld heat treatment. The temperature range for PWHT shall be 595-650°C. Other aspects such as rate of heating, holding time etc. for PWHT shall be as per ASME Sec.VIII, Div.I/ANSI B31.3 requirements. The hardness of the weldment after PWHT shall be 200 BHN maximum.





|                     |  |
|---------------------|--|
| 7470:TDG:001        | Technical Delivery Conditions<br>Project : IOCL Panipat Piping |
| Rev 00 DTD.21.02.22 | Item : SEAMLESS PIPES  |

**Item : Pipes A106GrB**

The following requirements are to be followed for supply of the pipe over and above the ASTM A 106 standard.

**Referred QAP – 7470:QPC:01 Rev 03 dtd 15.11.2021**

1. Pipes shall be procured strictly from Customer approved List attached separately along with the tender either directly from Mills / or from Traders.
2. Pipe made by acid-Bessemer process shall not be acceptable, steel pipe shall be made by open hearth, electric furnace or basic Oxygen process
3. All pipe shall be supplied in the normalized condition. Seamless pipe is acceptable hot finished (HFS condition).
4. Carbon Content (laddle analysis) shall not exceed **0.23%**.
5. CE shall not exceed **0.43%**, when calculated with formula  $CE = \%C + \%(\text{Mn}/6)$  and CE shall not exceed **0.45%**, when calculated with formula  $CE = C + (\text{Mn}/6) + ((\text{Cr} + \text{Mo} + \text{V})/5) + ((\text{Cu} + \text{Ni})/15)$ .
6. The Pipes shall not deviate from straightness by more than 1mm in any one meter and shall not be more than 6mm over the entire length. A sharp bend at the end or kink and twist are not acceptable.
7. All raw material tests viz. Chemical and Mechanical tests shall be conducted as per the standard. Records shall be furnished to Customer TPIA for review during raw material inspection (Hold stage). The original test certificate shall include relevant mechanical and chemical properties and conform to BS EN 10204 3.1B.
8. **All pipes shall be hydro tested** as per the requirements of the ASTM standard and shall also meet the requirements as mentioned in the attached QAP. The Hydrostatic Test Pressure shall be 15 Mpa for Pipe OD 406.4 mm X Thk 21.44 mm and OD 457.2 mm X Thk 23.88 mm.
9. **Charpy Impact testing** shall be carried out on all pipe of 20 mm wall thickness and greater in \ Accordance with ASME B31.3. Impact values shall be 27 Joules minimum average, 20 Joules minimum individual. Test temperature shall be minus 6°C. Full size test specimens (10 mm x 10 mm) shall be taken in a longitudinal direction. Impact testing shall be carried out on base – material, weld deposit and HAZ.
10. Tolerance on pipe OD and thickness shall be as per the ASTM A106 standard.
11. Quantity of pipe (Total length) shall be in positive tolerance only.



|   |   |  |   |
|---|---|--|---|
|  |  |  |  |
| D.Sandra Priya<br>Mgr / Q&BE  | K Rajitha<br>AGM / MM   | C Saravanan<br>AGM / Engineering   | K V Ramani<br>AGM / Q&BE  |
| Prepared by   | Reviewed by   |  | Approved by   |

|                     |  |
|---------------------|--|
| 7470:TDG:001        | Technical Delivery Conditions<br>Project : IOCL Panipat Piping |
| Rev 00 DTD.21.02.22 | Item : SEAMLESS PIPES  |

12. No weld seam is allowed between random pipe lengths supplied. Repair by welding is prohibited.
13. **WORKMANSHIP:** The Inside & outside surfaces of the pipes shall be free from any imperfections & defects like laps, seams, folds, cracks, pitting etc., Local depressions or ground spots are not acceptable.
14. Edge preparation shall be done as per drawing. DP test, Final inspection, Painting, Marking, Packing, End protection etc. shall be done as per the attached QAP.
15. TPIA appointed shall be any one from the List of Customer approved TPIA indicated as below.

M/s TUV SUD South Asia Pvt. Ltd.  
M/s Apave Assessments India Pvt Ltd  
M/s VCS Quality Services Private Ltd.  
M/s DNV GL AS  
M/s IR Class Systems & Solutions Private Limited  
M/s. Projects and Development India Ltd.  
M/s Tata Projects Limited  
M/s Lloyds Register Asia  
M/s Certification Engineers International Limited  
M/s Bureau Veritas (India) Pvt Ltd

16. All reports mentioned as 'D' in the column 'Format of Records' of the attached QAP shall be included in the documentation.
17. Material shall be supplied only after Despatch clearance from Customer. Vendors shall offer for BHEL / BHEL TPIA inspection at all stages of manufacturing as per the QAP.

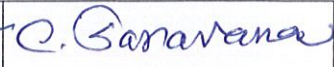
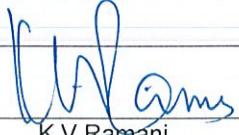
|   |   |  |   |
|---|---|--|---|
|  |  |  |  |
| D.Sandra Priya<br>Mgr / Q&BE  | K Rajitha<br>AGM / MM   | C Saravanan<br>AGM / Engineering   | K V Ramani<br>AGM / Q&BE  |
| Prepared by   | Reviewed by   |  | Approved by   |

| Worley                              |             | Document Status Code   |
|-------------------------------------|-------------|--|
| Status                              | Review Code | Status Description   |
| <input checked="" type="checkbox"/> | 1           | No Comments. Work may proceed.   |
| <input type="checkbox"/>            | 2           | The contractor shall proceed with the fabrication / manufacturing taking care of and incorporating Owner / PMC comments. Contractor shall submit the drawings / documents again duly incorporating Owner / PMC Comments. |
| <input type="checkbox"/>            | 3           | Major non-conformance and deviation to contract specifications and the document is rejected. Contractor is to resubmit for review after incorporating comments.  |
| <input type="checkbox"/>            | 4           | Document / Drawing Retained for Information.   |

Document status code assigned by:  
 Name: \_\_\_\_\_ Date: \_\_\_\_\_  
Manufacturers and suppliers remain responsible under all circumstances for their drawings, whether accepted without comments or accepted after alteration, in accordance with contract documents. The contractor shall be responsible for the accuracy of the drawings. Jacobs shall be entitled to sleep that Jacobs has by accepting the drawings taken over the responsibility for any defects in the drawings or the construction founded thereon.

|   |  |  |  |   |
|---|--|--|--|---|
|  | <b>MANUFACTURER'S NAME &amp; ADDRESS</b><br>BHEL PIPING CENTRE, CHENNAI<br>BHEL PPPU, THIRUMAYAM | <b>MANUFACTURING &amp; INSPECTION QUALITY PLAN FOR SUPPLY OF SEAMLESS CARBON STEEL PIPES</b><br><b>PIPE TUBE CS (SEAMLESS) TO ASTM STD</b> | <b>QP No:</b> 7470:QPC:01<br><b>REV No:</b> 03<br><b>DATE :</b> 15.11.2021 | <b>CUSTOMER :</b> IOCL, PANIPAT<br><b>CUSTOMER ORDER REF :</b> LOA REF : 7500/170<br><b>MAIN-SUPPLIER:</b> BHEL-PIPING CENTRE<br><b>BHEL CUSTOMER No:</b> P1 / 7470 |
|---|--|--|--|---|

| S. No | COMPONENT & OPERATIONS | CHARACTERISTICS | CLASS | TYPE OF CHECK | REFERENCE DOCUMENT | ACCEPTANCE NORMS | FORMAT OF RECORDS | AGENCY |   |   | REMARKS |
|-------|------------------------|-----------------|-------|---------------|--------------------|------------------|-------------------|--------|---|---|---------|
|       |                        |                 |       |               |                    |                  |                   | M      | B | C |         |
| 1     | 2                      | 3               | 4     | 5             | 6                  | 7                | 8                 | 9      |   |   | 10      |

**1.0 RAW MATERIAL:** Raw material shall be procured as per IOCL approved Vendor list either directly from supplier mills or from Traders.

|     |                       |  |          |                 |   |        |   |   |   |        |   |
|-----|-----------------------|--|----------|-----------------|---|--------|---|---|---|--------|---|
| 1.1 | Seamless Steel Pipes. | i) Chemical test<br>ii) Mechanical test    | Critical | TC verification | ASTM/ASME Material specification in BHEL GMS/DRG                    | Mfg Tc | D | P | R | R *    | * Hold Stage<br>a) Steel made by Acid Bessemer process is not acceptable.<br>b) Carbon content shall be as per Note 1 |
|     |                       | iii) HYDRO *                               | Critical | TC verification | ASTM/ASME Material specification in BHEL GMS/DRG                    | Mfg Tc | D | P | R | R / W@ | @ If Original MTC not available then 100% Hydro to be offered for TPIA witness - 'W' for 'C'.                         |
|     |                       | iv) Charpy Impact testing at minus 6 Deg C | Critical | TC verification | ASME B31.3 / Min. 27 Joules (Average) & Min. 20 Joules (Individual) | Mfg Tc | D | P | W | R *    | * Hold Stage  |

**2.0 IN PROCESS:**

|     |                  |  |       |             |                     |  |    |   |   |   |   |                        |
|-----|------------------|--|-------|-------------|---------------------|--|----|---|---|---|---|------------------------|
| 2.1 | Edge Preparation | a) Bevel end check and dimension check<br>b) DP test | Minor | Measurement | As per ASME B 16.25 |  | HC | - | P | R | W | Random witness by TPIA |
|-----|------------------|--|-------|-------------|---------------------|--|----|---|---|---|---|------------------------|

**3.0 FINAL INSPECTION:**

|     |                                       |  |       |             |                             |        |   |   |   |   |  |
|-----|---------------------------------------|--|-------|-------------|-----------------------------|--------|---|---|---|---|--|
| 3.1 | Visual Inspection and Dimension Check | OD, Thickness, Length, EP style, EP d1.. | Major | Measurement | Drawing/ In process records | Report | D | P | W | W | a) 100% Visual inspection at inside and outside surface of pipes by TPIA.<br>b) Thickness verification at Random over entire length of pipes |
|-----|---------------------------------------|--|-------|-------------|-----------------------------|--------|---|---|---|---|--|

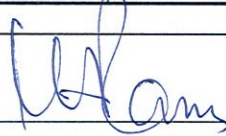

|   |  |  |   |  |   |  |  |  |  |                           |  |
|---|--|--|---|--|---|--|--|--|--|---------------------------|--|
| FOR MANUFACTURER USE:   |  |  |   |  | FOR TUV SUD USE:  |  |  |  |  | FOR CUSTOMER USE:         |  |
| <br>Sandra Priya D, DM / QA&BE |  |  | <br>K V Ramani, AGM / Q&BE |  | <b>M:</b> BHEL / PIPE MANUFACTURER / TRADER;<br><b>B:</b> BHEL QC;<br><b>C:</b> CUSTOMER /CUSTOMER'S TPIA.<br><b>H:</b> HOLD POINT (NOT TO PROCEED WITHOUT CLEARANCE)<br><b>P:</b> PERFORM (100%), <b>W:</b> WITNESS (100%),<br><b>R:</b> DOCUMENT REVIEW ONLY.<br><b>D:</b> REPORTS TO BE ESSENTIALLY INCLUDED IN DOCUMENTATION. |  |  |  |  |                           |  |
| PREPARED BY   |  |  | APPROVED BY   |  | APPROVED BY (NAME & SEAL)   |  |  |  |  | APPROVED BY (NAME & SEAL) |  |

|   |  |  |  |   |   |  |  |  |  |
|---|--|--|--|---|---|--|--|--|--|
|  | <b>MANUFACTURER'S NAME &amp; ADDRESS</b><br>BHEL PIPING CENTRE, CHENNAI<br>BHEL PPPU, THIRUMAYAM |  | <b>MANUFACTURING &amp; INSPECTION QUALITY PLAN FOR SUPPLY OF SEAMLESS CARBON STEEL PIPES</b> |   |   |  |  |  |  |
|   |  |  | <b>PIPE TUBE CS (SEAMLESS) TO ASTM STD</b>   | <b>QP No:</b> 7470:QPC:01<br><b>REV No:</b> 03<br><b>DATE:</b> 15.11.2021 | <b>CUSTOMER:</b> IOCL, PANIPAT<br><b>CUSTOMER ORDER REF:</b> LOA REF : 7500/170<br><b>MAIN-SUPPLIER:</b> BHEL-PIPING CENTRE<br><b>BHEL CUSTOMER No:</b> P1 / 7470 |  |  |  |  |

| S. No | COMPONENT & OPERATIONS               | CHARACTERISTICS       | CLASS    | TYPE OF CHECK            | REFERENCE DOCUMENT  | ACCEPTANCE NORMS | FORMAT OF RECORDS | AGENCY |   |   | REMARKS |  |
|-------|--------------------------------------|-----------------------|----------|--------------------------|---|------------------|-------------------|--------|---|---|---------|--|
|       |                                      |                       |          |                          |   |                  |                   | M      | B | C |         |  |
| 1     | 2                                    | 3                     | 4        | 5                        | 6   | 7                | 8                 | 9      |   |   | 10      |  |
| 3.2   | Identification Marking & Painting    | Painting & Color Code | Minor    | Visual & DFT Measurement | Refer Note 2 below  |                  | Report            | D      | P | W | V       | Witness at Final Stage   |
|       |                                      | Marking & Punching    | Major    | Visual                   | Refer Note 3 below  |                  | HC                | D      | P | W | W       |  |
| 3.3   | Packing & End protection             | Shipping protection   | Minor    | Visual                   | Refer Note 4 below  |                  | HC                | -      | P | R | -       |  |
| 3.4   | Inspection Release Certificate (IRC) | Compliance to MQP     | Critical | Compilation (1E+2P)      | Material TCs, Hydrotest, NDE & Dimension and Weight Reports |                  | IRN               | D      | P | R | H       | a) IRC to be issued by TPIA<br>b) Dispatch clearance by Worley on review of TPIA IRN, Inspection documents & TPIA signed off QAP.<br>c) (E-Electronic, P-Print copies) |

**NOTES**

- For Carbon Steel pipes Carbon content shall be as follows - a) Carbon Content (laddle analysis) shall not exceed 0.23%, b) CE shall not exceed 0.43%, when calculated with formula  $CE = \%C + \%(\text{Mn}/6)$  and c) CE shall not exceed 0.45%, when calculated with formula  $CE = C + (\text{Mn}/6) + ((\text{Cr} + \text{Mo} + \text{V})/5) + ((\text{Cu} + \text{Ni})/15)$ .
- Painting :- Rust preventive coating shall be applied on the Machined surfaces. Color Coding - Yellow (First color band shall start 2 inch from the pipe ends, width of the color strip shall be 25mm)
- Marking :- Paint stencilling at one end: Project name, Work Order, DU details(as per Engg drg) with Spool suffix. Hard Punching at one end: Work Order, Du details, Material spec and size. Stencilling & Punching shall be done in such a manner that any spool may be easily identified without turning or lifting it.
- Items shall be suitably packed to avoid storage & transit damages. Suitable end protectors shall be provided and they shall be properly secured and tightly attached.
- Items shall be dry, clean & free from moisture, dirt & loose foreign materials.
- Paint or ink for marking shall not contain any harmful metal or metal salts which can cause corrosive attack either ordinarily or in service.
- Raw material shall be procured as per IOCL approved Vendor list, either directly from supplier mills or from Traders.
- No weld seam is allowed between random pipe lengths supplied by BHEL. Dispatch clearance by Worley. TPIA shall be any TPIA as per IOCL list of TPIAs.
- Quantity of pipe (Total length) shall be in positive tolerance only.

| FOR MANUFACTURER USE:   |   | LEGEND:  | FOR TUV SUD USE:          | FOR CUSTOMER USE:         |
|---|---|--|---------------------------|---------------------------|
| <br>Sandra Priya D, DM / QA&BE | <br>K V Ramani, AGM / Q&BE | <b>M:</b> BHEL / PIPE MANUFACTURER / TRADER;<br><b>B:</b> BHEL QC;<br><b>C:</b> CUSTOMER / CUSTOMER'S TPIA.<br><b>H:</b> HOLD POINT (NOT TO PROCEED WITHOUT CLEARANCE)<br><b>P:</b> PERFORM (100%), <b>W:</b> WITNESS (100%),<br><b>R:</b> DOCUMENT REVIEW ONLY.<br><b>D:</b> REPORTS TO BE ESSENTIALLY INCLUDED IN DOCUMENTATION. |                           |                           |
| PREPARED BY   | APPROVED BY   |  | APPROVED BY (NAME & SEAL) | APPROVED BY (NAME & SEAL) |

CAUTION: The information on this document is the property of BHARAT HEAVY ELECTRICALS LTD. It must not be used directly or indirectly in any way detrimental to the interest of the company.

|           |      |          |
|-----------|------|----------|
| REV<br>01 | DATE | ALTERED  |
|           |      | APPROVED |

NOTES:  
 (1) FOLLOW APPLICABLE PROJECT QUALITY PLAN.  
 (2) FOLLOW APPLICABLE TDC.

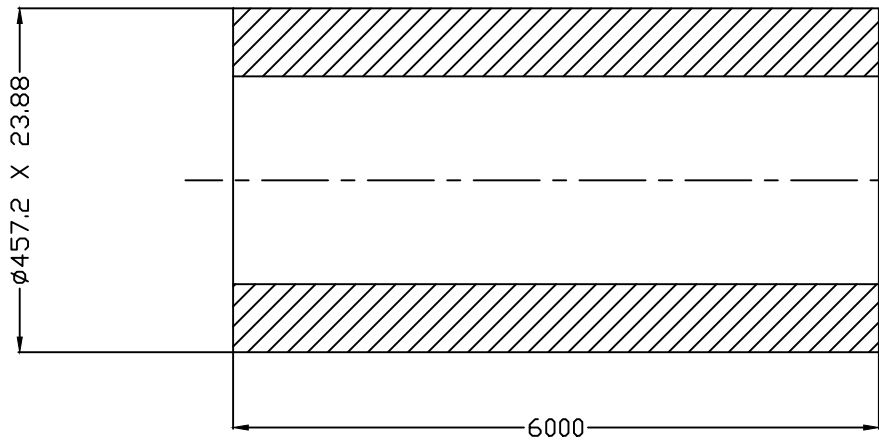

FOR EDGE PREPARATION  
 REFER DETAIL-A  
 (TYPICAL)

DETAIL-A

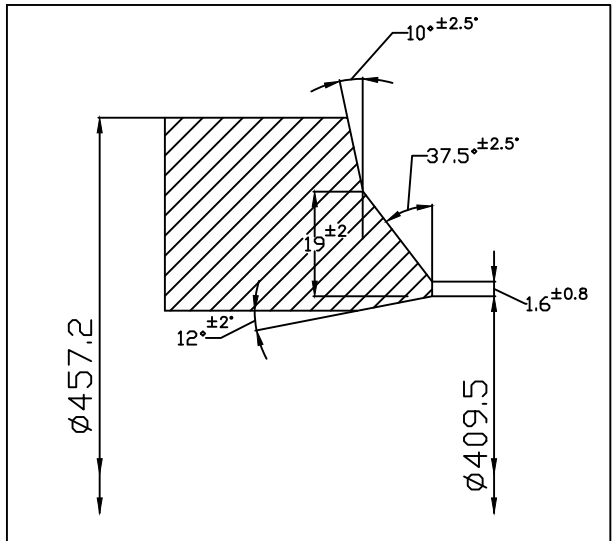

|                              |                 |     |          |
|------------------------------|-----------------|-----|----------|
| PIPE OD457.2X23.88<br>L=6000 | 15 982 473 6000 | C   | 1531.020 |
|                              | ASTM A106GRB    |     | 1        |
| VAR NO.                      | DESCRIPTION     | STD | UNIT     |
|                              |                 |     | DI       |
|                              |                 |     | QTY.     |



**BHARAT HEAVY ELECTRICALS LIMITED**  
 PIPING CENTRE  
 CHENNAI 600 017

|                   |      |          |               |
|-------------------|------|----------|---------------|
| NAME              | SIGN | DATE     | NO. OF<br>VAR |
| DRN. R.BHARATH    |      | 11.01.22 |               |
| CHD. IDB RAJU     |      | 11.01.22 |               |
| APPD. C.SARAVANAN |      | 11.01.22 |               |

|      |                       |  |       |             |                        |          |                 |
|------|-----------------------|--|-------|-------------|------------------------|----------|-----------------|
| DEPT | GRADE OF<br>UNTOL.DIM |  | SCALE | WEIGHT (KG) | REF. TO ASSY./OLD DRG. | ITEM NO. | NO. OF<br>ITEMS |
| CODE | C / M / F             |  | N.T.S | 1531.020    |                        |          |                 |

|                                      |     |                |     |
|--------------------------------------|-----|----------------|-----|
| TITLE                                | NTS | DRAWING NO.    | REV |
| PIPE OD457.2X23.88<br>(ASTM A106GRB) |     | 4-80-997-84475 | 00  |