

Bid Document

Bid Details	
Bid End Date/Time	09-05-2022 14:00:00
Bid Opening Date/Time	09-05-2022 14:30:00
Bid Offer Validity (From End Date)	80 (Days)
Ministry/State Name	Ministry Of Heavy Industries And Public Enterprises
Department Name	Department Of Heavy Industry
Organisation Name	Bharat Heavy Electricals Limited (bhel)
Office Name	10410005-pc Chennai
Total Quantity	51752
Item Category	411061610000 - STUD M16 X 2 X 100 SA193B16 , 411171610000 - FT STUD-M16x100 -B7 , 411171611000 - STUD M16 X 2 X 110 SA193B7 , 411171612000 - FT STUD- M16x120 -B7 , 411172012000 - FT STUD-M20x120 -B7 , 411172015000 - FT STUD-M20x150 -B7 , 411172414000 - FT STUD-M24x140 -B7 , 411172418000 - FT STUD-M24x180 -B7 , 411172718000 - FT STUD-M27x180 -B7 , 948222423700 - STUD M 24 X 3 X 230 SA193B7 , 948222723700 - STUD M27X3X230 SA193GRB7 , 948223629700 - STUD M36 X 4 X 290 SA193B7 , 413240001600 - NUT -M16 -GR7 , 413240003600 - Hex Nut M36x3-BPS 41324, VAR04 , 413244003600 - HEX NUT M36 X 4 SA194GR7 , 413244005600 - HEX NUT M56 X 4 SA194GR7 , 413245004800 - HEX NUT M48 X 5 SA194GR7 , 412152010002 - HEX BOLT M20X100 - GALVANISED - IS1367 , 412152412000 - BOLT-M24x120 -6.8-IS1364P1 , 412152712000 - HEX BOLT M27X3X120 P CL 6.8 GR A STEEL , 412211612000 - BOLT-M16x120 -4.6-IS1363P1 , 412212009000 - BOLT-M20x90 -4.6-IS1363P1 BPS 41221 , 413010002002 - HEX NUT M20 - GALVANISED - P CL 6 , 413040001000 - NUT -M10 -CL4-IS1363P3 , 413040002000 - NUT -M20 -CL4-IS1363P3 , 413040002400 - NUT -M24 - CL4-IS1363P3 , 413040005600 - BL HEX NUT M 56 X 4 P CL.4 GR C STEEL , 413190002400 - Hex Nut Gr B M24 T425 BPS 41319 , 413190003000 - NUT -M30 -2H , 413193003600 - NUT -M36x3 -2H , 413195004800 - HEX NUT M48 X 5 SA194GR2H , 413950052000 - HEX NUT M52 X 5 SA194GR2H , 414080003000 - PUNCHED WASHER A 33 IS 2016 - LATEST , 414080007200 - PUNCHED WASHER A 78- ID- IS 2016 , 417041006300 - SPLIT PIN 10x63 IS 549 , 417044002500 - SPLIT PIN-4x25 -IS 549 , 417046304500 - SPLIT PIN-6.3x45 -IS 549
BOQ Title	PROCUREMENT OF B7 B16 AND COMMERCIAL GRADE FASTENERS
Minimum Average Annual Turnover of the Bidder	6 Lakh (s)
Years of Past Experience required	3 Year (s)

Bid Details	
MSE Exemption for Years of Experience and Turnover	No
Startup Exemption for Years of Experience and Turnover	No
Document required from seller	Experience Criteria,Bidder Turnover,Certificate (Requested in ATC),Additional Doc 1 (Requested in ATC),Additional Doc 2 (Requested in ATC),Compliance of BoQ specification and supporting document *In case any bidder is seeking exemption from Experience / Turnover Criteria, the supporting documents to prove his eligibility for exemption must be uploaded for evaluation by the buyer
Bid to RA enabled	Yes
RA Qualification Rule	H1-Highest Priced Bid Elimination
Primary product category	417046304500 - SPLIT PIN-6.3x45 -IS 549
Time allowed for Technical Clarifications during technical evaluation	2 Days
Payment Timelines	Payments shall be made to the Seller within 90 days of issue of consignee receipt-cum-acceptance certificate (CRAC) and on-line submission of bills (This is in supersession of 10 days time as provided in clause 12 of GeM GTC)
Evaluation Method	Group wise evaluation

EMD Detail

Required	No
----------	----

ePBG Detail

Required	No
----------	----

(a). The EMD % will be applicable for each schedule/group selected during Bid creation.

Splitting

Bid splitting not applied.

MII Purchase Preference

MII Purchase Preference	Yes
-------------------------	-----

MSE Purchase Preference

MSE Purchase Preference	Yes
-------------------------	-----

1. The minimum average annual financial turnover of the bidder during the last three years, ending on 31st March of the previous financial year, should be as indicated above in the bid document. Documentary evidence in the form of certified Audited Balance Sheets of relevant periods or a certificate from the Chartered Accountant / Cost Accountant indicating the turnover details for the relevant period shall be uploaded with the bid. In case the date of constitution / incorporation of the bidder is less than 3-year-old, the average turnover in respect of the completed financial years after the date of constitution shall be taken into account for this criteria.

2. Experience Criteria: In respect of the filter applied for experience criteria, the Bidder or its OEM {themselves or through reseller(s)} should have regularly, manufactured and supplied same or similar Category Products to any Central / State Govt Organization / PSU / Public Listed Company for number of Financial years as indicated above in the bid document before the bid opening date. Copies of relevant contracts to be submitted along with bid in support of having supplied some quantity during each of the Financial year. In case of bunch bids, the category of primary product having highest value should meet this criterion.

3. Preference to Make In India products (For bids < 200 Crore):Preference shall be given to Class 1 local supplier as defined in public procurement (Preference to Make in India), Order 2017 as amended from time to time and its subsequent Orders/Notifications issued by concerned Nodal Ministry for specific Goods/Products. The minimum local content to qualify as a Class 1 local supplier is denoted in the bid document. If the bidder wants to avail the Purchase preference, the bidder must upload a certificate from the OEM regarding the percentage of the local content and the details of locations at which the local value addition is made along with their bid, failing which no purchase preference shall be granted. In case the bid value is more than Rs 10 Crore, the declaration relating to percentage of local content shall be certified by the statutory auditor or cost auditor, if the OEM is a company and by a practicing cost accountant or a chartered accountant for OEMs other than companies as per the Public Procurement (preference to Make-in -India) order 2017 dated 04.06.2020. Only Class-I and Class-II Local suppliers as per MII order dated 4.6.2020 will be eligible to bid. Non - Local suppliers as per MII order dated 04.06.2020 are not eligible to participate. However, eligible micro and small enterprises will be allowed to participate .In case Buyer has selected Purchase preference to Micro and Small Enterprises clause in the bid, the same will get precedence over this clause.

4. Purchase preference to Micro and Small Enterprises (MSEs): Purchase preference will be given to MSEs as defined in Public Procurement Policy for Micro and Small Enterprises (MSEs) Order, 2012 dated 23.03.2012 issued by Ministry of Micro, Small and Medium Enterprises and its subsequent Orders/Notifications issued by concerned Ministry. If the bidder wants to avail the Purchase preference, the bidder must be the manufacturer of the offered product in case of bid for supply of goods. Traders are excluded from the purview of Public Procurement Policy for Micro and Small Enterprises. In respect of bid for Services, the bidder must be the Service provider of the offered Service. Relevant documentary evidence in this regard shall be uploaded along with the bid in respect of the offered product or service. If L-1 is not an MSE and MSE Seller (s) has/have quoted price within L-1+ 15% (Selected by Buyer)of margin of purchase preference /price band defined in relevant policy, such Seller shall be given opportunity to match L-1 price and contract will be awarded for 25%(selected by Buyer) percentage of total QUANTITY.

5. Estimated Bid Value indicated above is being declared solely for the purpose of guidance on EMD amount and for determining the Eligibility Criteria related to Turn Over, Past Performance and Project / Past Experience etc. This has no relevance or bearing on the price to be quoted by the bidders and is also not going to have any impact on bid participation. Also this is not going to be used as a criteria in determining reasonableness of quoted prices which would be determined by the buyer based on its own assessment of reasonableness and based on competitive prices received in Bid / RA process.

6. Reverse Auction would be conducted amongst all the technically qualified bidders except the Highest quoting bidder. The technically qualified Highest Quoting bidder will not be allowed to participate in RA. However, H-1 will also be allowed to participate in RA in following cases:

- i. If number of technically qualified bidders are only 2 or 3.
- ii. If Buyer has chosen to split the bid amongst N sellers, and H1 bid is coming within N.
- iii. In case Primary product of only one OEM is left in contention for participation in RA on elimination of H-1.
- iv. If L-1 is non-MSE and H-1 is eligible MSE and H-1 price is coming within price band of 15% of Non-MSE L-1
- v. If L-1 is non-MII and H-1 is eligible MII and H-1 price is coming within price band of 20% of Non-MII L-1

Evaluation Method (Group Wise Evaluation Method)

Contract will be awarded schedulewise and the determination of L1 will be done separately for each schedule. The details of item-consignee combination covered under each schedule are as under:

Evaluation Schedules	Item/Category	Consignee/Reporting Officer	Consignee Address	Quantity
Schedule 1	411061610000 - Stud M16 X 2 X 100 Sa193b16	Billa Kumar Gangaraju	Ward 55, BHEL Trichy Stores, Tiruchirappalli - 620014. 620014	116
Schedule 2	411171610000 - Ft Stud-m16x100 -b7	Billa Kumar Gangaraju	Ward 55, BHEL Trichy Stores, Tiruchirappalli - 620014. 620014	45
	411171611000 - Stud M16 X 2 X 110 Sa193b7	Billa Kumar Gangaraju	Ward 55, BHEL Trichy Stores, Tiruchirappalli - 620014. 620014	54
	411171612000 - Ft Stud-m16x120 -b7	Billa Kumar Gangaraju	Ward 55, BHEL Trichy Stores, Tiruchirappalli - 620014. 620014	696
	411172012000 - Ft Stud-m20x120 -b7	Billa Kumar Gangaraju	Ward 55, BHEL Trichy Stores, Tiruchirappalli - 620014. 620014	757
	411172015000 - Ft Stud-m20x150 -b7	Billa Kumar Gangaraju	Ward 55, BHEL Trichy Stores, Tiruchirappalli - 620014. 620014	476
	411172414000 - Ft Stud-m24x140 -b7	Billa Kumar Gangaraju	Ward 55, BHEL Trichy Stores, Tiruchirappalli - 620014. 620014	92
	411172418000 - Ft Stud-m24x180 -b7	Billa Kumar Gangaraju	Ward 55, BHEL Trichy Stores, Tiruchirappalli - 620014. 620014	70
	411172718000 - Ft Stud-m27x180 -b7	Billa Kumar Gangaraju	Ward 55, BHEL Trichy Stores, Tiruchirappalli - 620014. 620014	126
	948222423700 - Stud M 24 X 3 X 230 Sa193b7	Billa Kumar Gangaraju	Ward 55, BHEL Trichy Stores, Tiruchirappalli - 620014. 620014	228
	948222723700 - Stud M27x3x230 Sa193grb7	Billa Kumar Gangaraju	Ward 55, BHEL Trichy Stores, Tiruchirappalli - 620014. 620014	150
	948223629700 - Stud M36 X 4 X 290 Sa193b7	Billa Kumar Gangaraju	Ward 55, BHEL Trichy Stores, Tiruchirappalli - 620014. 620014	28
	413240001600 - Nut -m16 -gr7	Billa Kumar Gangaraju	Ward 55, BHEL Trichy Stores, Tiruchirappalli - 620014. 620014	288
	413240003600 - Hex Nut M36x3-bps 41324, Var04	Billa Kumar Gangaraju	Ward 55, BHEL Trichy Stores, Tiruchirappalli - 620014. 620014	12
	413244003600 - Hex Nut M36 X 4 Sa194gr7	Billa Kumar Gangaraju	Ward 55, BHEL Trichy Stores, Tiruchirappalli - 620014. 620014	4304
	413244005600 - Hex Nut M56 X 4 Sa194gr7	Billa Kumar Gangaraju	Ward 55, BHEL Trichy Stores, Tiruchirappalli - 620014. 620014	156
	413245004800 - Hex Nut M48 X 5 Sa194gr7	Billa Kumar Gangaraju	Ward 55, BHEL Trichy Stores, Tiruchirappalli - 620014. 620014	343
	412152010002 - Hex Bolt M20x100 - Galvanised - Is1367	Billa Kumar Gangaraju	Ward 55, BHEL Trichy Stores, Tiruchirappalli - 620014. 620014	200
	412152412000 - Bolt-m24x120 -6.8-is1364p1	Billa Kumar Gangaraju	Ward 55, BHEL Trichy Stores, Tiruchirappalli - 620014. 620014	100
	412152712000 - Hex Bolt M27x3x120 P Cl 6.8 Gr A Steel	Billa Kumar Gangaraju	Ward 55, BHEL Trichy Stores, Tiruchirappalli - 620014. 620014	548
412211612000 - Bolt-m16x120 -4.6-is1363p1	Billa Kumar Gangaraju	Ward 55, BHEL Trichy Stores, Tiruchirappalli - 620014. 620014	16	

Schedule 3	412212009000 - Bolt-m20x90 - 4.6-is1363p1 Bps 41221	Billa Kumar Gangaraju	Ward 55, BHEL Trichy Stores, Tiruchirappalli - 620014. 620014	645
	413010002002 - Hex Nut M20 - Galvanised - P Cl 6	Billa Kumar Gangaraju	Ward 55, BHEL Trichy Stores, Tiruchirappalli - 620014. 620014	200
	413040001000 - Nut -m10 -cl4-is1363p3	Billa Kumar Gangaraju	Ward 55, BHEL Trichy Stores, Tiruchirappalli - 620014. 620014	235 64
	413040002000 - Nut -m20 -cl4-is1363p3	Billa Kumar Gangaraju	Ward 55, BHEL Trichy Stores, Tiruchirappalli - 620014. 620014	131 41
	413040002400 - Nut -m24 -cl4-is1363p3	Billa Kumar Gangaraju	Ward 55, BHEL Trichy Stores, Tiruchirappalli - 620014. 620014	26
	413040005600 - BI Hex Nut M 56 X 4 P Cl.4 Gr C Steel	Billa Kumar Gangaraju	Ward 55, BHEL Trichy Stores, Tiruchirappalli - 620014. 620014	331
	413190002400 - Hex Nut Gr B M24 T425 Bps 41319	Billa Kumar Gangaraju	Ward 55, BHEL Trichy Stores, Tiruchirappalli - 620014. 620014	746
	413190003000 - Nut -m30 -2h	Billa Kumar Gangaraju	Ward 55, BHEL Trichy Stores, Tiruchirappalli - 620014. 620014	880
	413193003600 - Nut -m36x3 - 2h	Billa Kumar Gangaraju	Ward 55, BHEL Trichy Stores, Tiruchirappalli - 620014. 620014	650
	413195004800 - Hex Nut M48 X 5 Sa194gr2h	Billa Kumar Gangaraju	Ward 55, BHEL Trichy Stores, Tiruchirappalli - 620014. 620014	27
	413950052000 - Hex Nut M52 X 5 Sa194gr2h	Billa Kumar Gangaraju	Ward 55, BHEL Trichy Stores, Tiruchirappalli - 620014. 620014	600
	414080003000 - Punched Washer A 33 Is 2016 - Latest	Billa Kumar Gangaraju	Ward 55, BHEL Trichy Stores, Tiruchirappalli - 620014. 620014	472
	414080007200 - Punched Washer A 78-id- Is 2016	Billa Kumar Gangaraju	Ward 55, BHEL Trichy Stores, Tiruchirappalli - 620014. 620014	105
	417041006300 - Split Pin 10x63 Is 549	Billa Kumar Gangaraju	Ward 55, BHEL Trichy Stores, Tiruchirappalli - 620014. 620014	556
	417044002500 - Split Pin-4x25 - is 549	Billa Kumar Gangaraju	Ward 55, BHEL Trichy Stores, Tiruchirappalli - 620014. 620014	240
	417046304500 - Split Pin- 6.3x45 -is 549	Billa Kumar Gangaraju	Ward 55, BHEL Trichy Stores, Tiruchirappalli - 620014. 620014	764

411061610000 - STUD M16 X 2 X 100 SA193B16

(Minimum 50% and 20% Local Content required for qualifying as Class 1 and Class 2 Local Supplier respectively)

Brand Type	Unbranded
------------	-----------

Technical Specifications

Specification Document	View File
BOQ Detail Document	View File

Advisory-Please refer attached BOQ document for detailed consignee list and delivery period.

Consignees/Reporting Officer and Quantity

S.No.	Consignee/Reporting Officer	Address	Quantity	Delivery Days
1	Billa Kumar Gangaraju	620014,Ward 55, BHEL Trichy Stores, Tiruchirappalli - 620014.	116	60

411171610000 - FT STUD-M16x100 -B7

(Minimum 50% and 20% Local Content required for qualifying as Class 1 and Class 2 Local Supplier respectively)

Brand Type	Unbranded
------------	-----------

Technical Specifications

Specification Document	View File
BOQ Detail Document	View File

Advisory-Please refer attached BOQ document for detailed consignee list and delivery period.

Consignees/Reporting Officer and Quantity

S.No.	Consignee/Reporting Officer	Address	Quantity	Delivery Days
1	Billa Kumar Gangaraju	620014,Ward 55, BHEL Trichy Stores, Tiruchirappalli - 620014.	45	60

411171611000 - STUD M16 X 2 X 110 SA193B7

(Minimum 50% and 20% Local Content required for qualifying as Class 1 and Class 2 Local Supplier respectively)

Brand Type	Unbranded
------------	-----------

Technical Specifications

Specification Document	View File
BOQ Detail Document	View File

Advisory-Please refer attached BOQ document for detailed consignee list and delivery period.

Consignees/Reporting Officer and Quantity

S.No.	Consignee/Reporting Officer	Address	Quantity	Delivery Days
1	Billa Kumar Gangaraju	620014,Ward 55, BHEL Trichy Stores, Tiruchirappalli - 620014.	54	60

411171612000 - FT STUD-M16x120 -B7

(Minimum 50% and 20% Local Content required for qualifying as Class 1 and Class 2 Local Supplier respectively)

Brand Type	Unbranded
------------	-----------

Technical Specifications

Specification Document	View File
BOQ Detail Document	View File

Advisory-Please refer attached BOQ document for detailed consignee list and delivery period.

Consignees/Reporting Officer and Quantity

S.No.	Consignee/Reporting Officer	Address	Quantity	Delivery Days
1	Billa Kumar Gangaraju	620014,Ward 55, BHEL Trichy Stores, Tiruchirappalli - 620014.	696	60

411172012000 - FT STUD-M20x120 -B7

(Minimum 50% and 20% Local Content required for qualifying as Class 1 and Class 2 Local Supplier respectively)

Brand Type	Unbranded
------------	-----------

Technical Specifications

Specification Document	View File
BOQ Detail Document	View File

Advisory-Please refer attached BOQ document for detailed consignee list and delivery period.

Consignees/Reporting Officer and Quantity

S.No.	Consignee/Reporting Officer	Address	Quantity	Delivery Days
1	Billa Kumar Gangaraju	620014,Ward 55, BHEL Trichy Stores, Tiruchirappalli - 620014.	757	60

411172015000 - FT STUD-M20x150 -B7

(Minimum 50% and 20% Local Content required for qualifying as Class 1 and Class 2 Local Supplier respectively)

Brand Type	Unbranded
------------	-----------

Technical Specifications

Specification Document	View File
BOQ Detail Document	View File

Advisory-Please refer attached BOQ document for detailed consignee list and delivery period.

Consignees/Reporting Officer and Quantity

S.No.	Consignee/Reporting Officer	Address	Quantity	Delivery Days
1	Billa Kumar Gangaraju	620014,Ward 55, BHEL Trichy Stores, Tiruchirappalli - 620014.	476	60

411172414000 - FT STUD-M24x140 -B7

(Minimum 50% and 20% Local Content required for qualifying as Class 1 and Class 2 Local Supplier respectively)

Brand Type	Unbranded
------------	-----------

Technical Specifications

Specification Document	View File
BOQ Detail Document	View File

Advisory-Please refer attached BOQ document for detailed consignee list and delivery period.

Consignees/Reporting Officer and Quantity

S.No.	Consignee/Reporting Officer	Address	Quantity	Delivery Days
1	Billa Kumar Gangaraju	620014,Ward 55, BHEL Trichy Stores, Tiruchirappalli - 620014.	92	60

411172418000 - FT STUD-M24x180 -B7

(Minimum 50% and 20% Local Content required for qualifying as Class 1 and Class 2 Local Supplier respectively)

Brand Type	Unbranded
------------	-----------

Technical Specifications

Specification Document	View File
BOQ Detail Document	View File

Advisory-Please refer attached BOQ document for detailed consignee list and delivery period.

Consignees/Reporting Officer and Quantity

S.No.	Consignee/Reporting Officer	Address	Quantity	Delivery Days
1	Billa Kumar Gangaraju	620014,Ward 55, BHEL Trichy Stores, Tiruchirappalli - 620014.	70	60

411172718000 - FT STUD-M27x180 -B7

(Minimum 50% and 20% Local Content required for qualifying as Class 1 and Class 2 Local Supplier respectively)

Brand Type	Unbranded
------------	-----------

Technical Specifications

Specification Document	View File
BOQ Detail Document	View File

Advisory-Please refer attached BOQ document for detailed consignee list and delivery period.

Consignees/Reporting Officer and Quantity

S.No.	Consignee/Reporting Officer	Address	Quantity	Delivery Days
1	Billa Kumar Gangaraju	620014,Ward 55, BHEL Trichy Stores, Tiruchirappalli - 620014.	126	60

948222423700 - STUD M 24 X 3 X 230 SA193B7

(Minimum 50% and 20% Local Content required for qualifying as Class 1 and Class 2 Local Supplier respectively)

Brand Type	Unbranded
------------	-----------

Technical Specifications

Specification Document	View File
BOQ Detail Document	View File

Advisory-Please refer attached BOQ document for detailed consignee list and delivery period.

Consignees/Reporting Officer and Quantity

S.No.	Consignee/Reporting Officer	Address	Quantity	Delivery Days
1	Billa Kumar Gangaraju	620014,Ward 55, BHEL Trichy Stores, Tiruchirappalli - 620014.	228	60

948222723700 - STUD M27X3X230 SA193GRB7

(Minimum 50% and 20% Local Content required for qualifying as Class 1 and Class 2 Local Supplier respectively)

Brand Type	Unbranded
------------	-----------

Technical Specifications

Specification Document	View File
BOQ Detail Document	View File

Advisory-Please refer attached BOQ document for detailed consignee list and delivery period.

Consignees/Reporting Officer and Quantity

S.No.	Consignee/Reporting Officer	Address	Quantity	Delivery Days
1	Billa Kumar Gangaraju	620014,Ward 55, BHEL Trichy Stores, Tiruchirappalli - 620014.	150	60

948223629700 - STUD M36 X 4 X 290 SA193B7

(Minimum 50% and 20% Local Content required for qualifying as Class 1 and Class 2 Local Supplier respectively)

Brand Type	Unbranded
------------	-----------

Technical Specifications

Specification Document	View File
BOQ Detail Document	View File

Advisory-Please refer attached BOQ document for detailed consignee list and delivery period.

Consignees/Reporting Officer and Quantity

S.No.	Consignee/Reporting Officer	Address	Quantity	Delivery Days
1	Billa Kumar Gangaraju	620014,Ward 55, BHEL Trichy Stores, Tiruchirappalli - 620014.	28	60

413240001600 - NUT -M16 -GR7

(Minimum 50% and 20% Local Content required for qualifying as Class 1 and Class 2 Local Supplier respectively)

Brand Type	Unbranded
------------	-----------

Technical Specifications

Specification Document	View File
BOQ Detail Document	View File

Advisory-Please refer attached BOQ document for detailed consignee list and delivery period.

Consignees/Reporting Officer and Quantity

S.No.	Consignee/Reporting Officer	Address	Quantity	Delivery Days
1	Billa Kumar Gangaraju	620014,Ward 55, BHEL Trichy Stores, Tiruchirappalli - 620014.	288	60

413240003600 - Hex Nut M36x3-BPS 41324, VAR04

(Minimum 50% and 20% Local Content required for qualifying as Class 1 and Class 2 Local Supplier respectively)

Brand Type	Unbranded
------------	-----------

Technical Specifications

Specification Document	View File
BOQ Detail Document	View File

Advisory-Please refer attached BOQ document for detailed consignee list and delivery period.

Consignees/Reporting Officer and Quantity

S.No.	Consignee/Reporting Officer	Address	Quantity	Delivery Days
1	Billa Kumar Gangaraju	620014,Ward 55, BHEL Trichy Stores, Tiruchirappalli - 620014.	12	60

413244003600 - HEX NUT M36 X 4 SA194GR7

(Minimum 50% and 20% Local Content required for qualifying as Class 1 and Class 2 Local Supplier respectively)

Brand Type	Unbranded
------------	-----------

Technical Specifications

Specification Document	View File
BOQ Detail Document	View File

Advisory-Please refer attached BOQ document for detailed consignee list and delivery period.

Consignees/Reporting Officer and Quantity

S.No.	Consignee/Reporting Officer	Address	Quantity	Delivery Days
1	Billa Kumar Gangaraju	620014,Ward 55, BHEL Trichy Stores, Tiruchirappalli - 620014.	4304	60

413244005600 - HEX NUT M56 X 4 SA194GR7

(Minimum 50% and 20% Local Content required for qualifying as Class 1 and Class 2 Local Supplier respectively)

Brand Type	Unbranded
------------	-----------

Technical Specifications

Specification Document	View File
BOQ Detail Document	View File

Advisory-Please refer attached BOQ document for detailed consignee list and delivery period.

Consignees/Reporting Officer and Quantity

S.No.	Consignee/Reporting Officer	Address	Quantity	Delivery Days
1	Billa Kumar Gangaraju	620014,Ward 55, BHEL Trichy Stores, Tiruchirappalli - 620014.	156	60

413245004800 - HEX NUT M48 X 5 SA194GR7

(Minimum 50% and 20% Local Content required for qualifying as Class 1 and Class 2 Local Supplier respectively)

Brand Type	Unbranded
------------	-----------

Technical Specifications

Specification Document	View File
BOQ Detail Document	View File

Advisory-Please refer attached BOQ document for detailed consignee list and delivery period.

Consignees/Reporting Officer and Quantity

S.No.	Consignee/Reporting Officer	Address	Quantity	Delivery Days
1	Billa Kumar Gangaraju	620014,Ward 55, BHEL Trichy Stores, Tiruchirappalli - 620014.	343	60

412152010002 - HEX BOLT M20X100 - GALVANISED - IS1367

(Minimum 50% and 20% Local Content required for qualifying as Class 1 and Class 2 Local Supplier respectively)

Brand Type	Unbranded
------------	-----------

Technical Specifications

Specification Document	View File
BOQ Detail Document	View File

Advisory-Please refer attached BOQ document for detailed consignee list and delivery period.

Consignees/Reporting Officer and Quantity

S.No.	Consignee/Reporting Officer	Address	Quantity	Delivery Days
1	Billa Kumar Gangaraju	620014,Ward 55, BHEL Trichy Stores, Tiruchirappalli - 620014.	200	60

412152412000 - BOLT-M24x120 -6.8-IS1364P1

(Minimum 50% and 20% Local Content required for qualifying as Class 1 and Class 2 Local Supplier respectively)

Brand Type	Unbranded
------------	-----------

Technical Specifications

Specification Document	View File
BOQ Detail Document	View File

Advisory-Please refer attached BOQ document for detailed consignee list and delivery period.

Consignees/Reporting Officer and Quantity

S.No.	Consignee/Reporting Officer	Address	Quantity	Delivery Days
1	Billa Kumar Gangaraju	620014,Ward 55, BHEL Trichy Stores, Tiruchirappalli - 620014.	100	60

412152712000 - HEX BOLT M27X3X120 P CL 6.8 GR A STEEL

(Minimum 50% and 20% Local Content required for qualifying as Class 1 and Class 2 Local Supplier respectively)

Brand Type	Unbranded
------------	-----------

Technical Specifications

Specification Document	View File
BOQ Detail Document	View File

Advisory-Please refer attached BOQ document for detailed consignee list and delivery period.

Consignees/Reporting Officer and Quantity

S.No.	Consignee/Reporting Officer	Address	Quantity	Delivery Days
1	Billa Kumar Gangaraju	620014,Ward 55, BHEL Trichy Stores, Tiruchirappalli - 620014.	548	60

412211612000 - BOLT-M16x120 -4.6-IS1363P1

(Minimum 50% and 20% Local Content required for qualifying as Class 1 and Class 2 Local Supplier respectively)

Brand Type	Unbranded
------------	-----------

Technical Specifications

Specification Document	View File
BOQ Detail Document	View File

Advisory-Please refer attached BOQ document for detailed consignee list and delivery period.

Consignees/Reporting Officer and Quantity

S.No.	Consignee/Reporting Officer	Address	Quantity	Delivery Days
1	Billa Kumar Gangaraju	620014,Ward 55, BHEL Trichy Stores, Tiruchirappalli - 620014.	16	60

412212009000 - BOLT-M20x90 -4.6-IS1363P1 BPS 41221

(Minimum 50% and 20% Local Content required for qualifying as Class 1 and Class 2 Local Supplier respectively)

Brand Type	Unbranded
------------	-----------

Technical Specifications

Specification Document	View File
BOQ Detail Document	View File

Advisory-Please refer attached BOQ document for detailed consignee list and delivery period.

Consignees/Reporting Officer and Quantity

S.No.	Consignee/Reporting Officer	Address	Quantity	Delivery Days
1	Billa Kumar Gangaraju	620014,Ward 55, BHEL Trichy Stores, Tiruchirappalli - 620014.	645	60

413010002002 - HEX NUT M20 - GALVANISED - P CL 6

(Minimum 50% and 20% Local Content required for qualifying as Class 1 and Class 2 Local Supplier respectively)

Brand Type	Unbranded
------------	-----------

Technical Specifications

Specification Document	View File
BOQ Detail Document	View File

Advisory-Please refer attached BOQ document for detailed consignee list and delivery period.

Consignees/Reporting Officer and Quantity

S.No.	Consignee/Reporting Officer	Address	Quantity	Delivery Days
1	Billa Kumar Gangaraju	620014,Ward 55, BHEL Trichy Stores, Tiruchirappalli - 620014.	200	60

413040001000 - NUT -M10 -CL4-IS1363P3

(Minimum 50% and 20% Local Content required for qualifying as Class 1 and Class 2 Local Supplier respectively)

Brand Type	Unbranded
------------	-----------

Technical Specifications

Specification Document	View File
BOQ Detail Document	View File

Advisory-Please refer attached BOQ document for detailed consignee list and delivery period.

Consignees/Reporting Officer and Quantity

S.No.	Consignee/Reporting Officer	Address	Quantity	Delivery Days
1	Billa Kumar Gangaraju	620014,Ward 55, BHEL Trichy Stores, Tiruchirappalli - 620014.	23564	60

413040002000 - NUT -M20 -CL4-IS1363P3

(Minimum 50% and 20% Local Content required for qualifying as Class 1 and Class 2 Local Supplier respectively)

Brand Type	Unbranded
------------	-----------

Technical Specifications

Specification Document	View File
BOQ Detail Document	View File

Advisory-Please refer attached BOQ document for detailed consignee list and delivery period.

Consignees/Reporting Officer and Quantity

S.No.	Consignee/Reporting Officer	Address	Quantity	Delivery Days
1	Billa Kumar Gangaraju	620014,Ward 55, BHEL Trichy Stores, Tiruchirappalli - 620014.	13141	60

413040002400 - NUT -M24 -CL4-IS1363P3

(Minimum 50% and 20% Local Content required for qualifying as Class 1 and Class 2 Local Supplier respectively)

Brand Type	Unbranded
------------	-----------

Technical Specifications

Specification Document	View File
BOQ Detail Document	View File

Advisory-Please refer attached BOQ document for detailed consignee list and delivery period.

Consignees/Reporting Officer and Quantity

S.No.	Consignee/Reporting Officer	Address	Quantity	Delivery Days
1	Billa Kumar Gangaraju	620014,Ward 55, BHEL Trichy Stores, Tiruchirappalli - 620014.	26	60

413040005600 - BL HEX NUT M 56 X 4 P CL.4 GR C STEEL

(Minimum 50% and 20% Local Content required for qualifying as Class 1 and Class 2 Local Supplier respectively)

Brand Type	Unbranded
------------	-----------

Technical Specifications

Specification Document	View File
BOQ Detail Document	View File

Advisory-Please refer attached BOQ document for detailed consignee list and delivery period.

Consignees/Reporting Officer and Quantity

S.No.	Consignee/Reporting Officer	Address	Quantity	Delivery Days
1	Billa Kumar Gangaraju	620014,Ward 55, BHEL Trichy Stores, Tiruchirappalli - 620014.	331	60

413190002400 - Hex Nut Gr B M24 T425 BPS 41319

(Minimum 50% and 20% Local Content required for qualifying as Class 1 and Class 2 Local Supplier respectively)

Brand Type	Unbranded
------------	-----------

Technical Specifications

Specification Document	View File
BOQ Detail Document	View File

Advisory-Please refer attached BOQ document for detailed consignee list and delivery period.

Consignees/Reporting Officer and Quantity

S.No.	Consignee/Reporting Officer	Address	Quantity	Delivery Days
1	Billa Kumar Gangaraju	620014,Ward 55, BHEL Trichy Stores, Tiruchirappalli - 620014.	746	60

413190003000 - NUT -M30 -2H

(Minimum 50% and 20% Local Content required for qualifying as Class 1 and Class 2 Local Supplier respectively)

Brand Type	Unbranded
------------	-----------

Technical Specifications

Specification Document	View File
BOQ Detail Document	View File

Advisory-Please refer attached BOQ document for detailed consignee list and delivery period.

Consignees/Reporting Officer and Quantity

S.No.	Consignee/Reporting Officer	Address	Quantity	Delivery Days
1	Billa Kumar Gangaraju	620014,Ward 55, BHEL Trichy Stores, Tiruchirappalli - 620014.	880	60

413193003600 - NUT -M36x3 -2H

(Minimum 50% and 20% Local Content required for qualifying as Class 1 and Class 2 Local Supplier respectively)

Brand Type	Unbranded
------------	-----------

Technical Specifications

Specification Document	View File
BOQ Detail Document	View File

Advisory-Please refer attached BOQ document for detailed consignee list and delivery period.

Consignees/Reporting Officer and Quantity

S.No.	Consignee/Reporting Officer	Address	Quantity	Delivery Days
1	Billa Kumar Gangaraju	620014,Ward 55, BHEL Trichy Stores, Tiruchirappalli - 620014.	650	60

413195004800 - HEX NUT M48 X 5 SA194GR2H

(Minimum 50% and 20% Local Content required for qualifying as Class 1 and Class 2 Local Supplier respectively)

Brand Type	Unbranded
------------	-----------

Technical Specifications

Specification Document	View File
BOQ Detail Document	View File

Advisory-Please refer attached BOQ document for detailed consignee list and delivery period.

Consignees/Reporting Officer and Quantity

S.No.	Consignee/Reporting Officer	Address	Quantity	Delivery Days
1	Billa Kumar Gangaraju	620014,Ward 55, BHEL Trichy Stores, Tiruchirappalli - 620014.	27	60

413950052000 - HEX NUT M52 X 5 SA194GR2H

(Minimum 50% and 20% Local Content required for qualifying as Class 1 and Class 2 Local Supplier respectively)

Brand Type	Unbranded
------------	-----------

Technical Specifications

Specification Document	View File
BOQ Detail Document	View File

Advisory-Please refer attached BOQ document for detailed consignee list and delivery period.

Consignees/Reporting Officer and Quantity

S.No.	Consignee/Reporting Officer	Address	Quantity	Delivery Days
1	Billa Kumar Gangaraju	620014,Ward 55, BHEL Trichy Stores, Tiruchirappalli - 620014.	600	60

414080003000 - PUNCHED WASHER A 33 IS 2016 - LATEST

(Minimum 50% and 20% Local Content required for qualifying as Class 1 and Class 2 Local Supplier respectively)

Brand Type	Unbranded
------------	-----------

Technical Specifications

Specification Document	View File
BOQ Detail Document	View File

Advisory-Please refer attached BOQ document for detailed consignee list and delivery period.

Consignees/Reporting Officer and Quantity

S.No.	Consignee/Reporting Officer	Address	Quantity	Delivery Days
1	Billa Kumar Gangaraju	620014,Ward 55, BHEL Trichy Stores, Tiruchirappalli - 620014.	472	60

414080007200 - PUNCHED WASHER A 78-ID- IS 2016

(Minimum 50% and 20% Local Content required for qualifying as Class 1 and Class 2 Local Supplier respectively)

Brand Type	Unbranded
------------	-----------

Technical Specifications

Specification Document	View File
BOQ Detail Document	View File

Advisory-Please refer attached BOQ document for detailed consignee list and delivery period.

Consignees/Reporting Officer and Quantity

S.No.	Consignee/Reporting Officer	Address	Quantity	Delivery Days
1	Billa Kumar Gangaraju	620014,Ward 55, BHEL Trichy Stores, Tiruchirappalli - 620014.	105	60

417041006300 - SPLIT PIN 10x63 IS 549

(Minimum 50% and 20% Local Content required for qualifying as Class 1 and Class 2 Local Supplier respectively)

Brand Type	Unbranded
------------	-----------

Technical Specifications

Specification Document	View File
BOQ Detail Document	View File

Advisory-Please refer attached BOQ document for detailed consignee list and delivery period.

Consignees/Reporting Officer and Quantity

S.No.	Consignee/Reporting Officer	Address	Quantity	Delivery Days
1	Billa Kumar Gangaraju	620014,Ward 55, BHEL Trichy Stores, Tiruchirappalli - 620014.	556	60

417044002500 - SPLIT PIN-4x25 -IS 549

(Minimum 50% and 20% Local Content required for qualifying as Class 1 and Class 2 Local Supplier respectively)

Brand Type	Unbranded
------------	-----------

Technical Specifications

Specification Document	View File
BOQ Detail Document	View File

Advisory-Please refer attached BOQ document for detailed consignee list and delivery period.

Consignees/Reporting Officer and Quantity

S.No.	Consignee/Reporting Officer	Address	Quantity	Delivery Days
1	Billa Kumar Gangaraju	620014,Ward 55, BHEL Trichy Stores, Tiruchirappalli - 620014.	240	60

417046304500 - SPLIT PIN-6.3x45 -IS 549

(Minimum 50% and 20% Local Content required for qualifying as Class 1 and Class 2 Local Supplier respectively)

Brand Type	Unbranded
------------	-----------

Technical Specifications

Specification Document	View File
BOQ Detail Document	View File

Advisory-Please refer attached BOQ document for detailed consignee list and delivery period.

Consignees/Reporting Officer and Quantity

S.No.	Consignee/Reporting Officer	Address	Quantity	Delivery Days
1	Billa Kumar Gangaraju	620014,Ward 55, BHEL Trichy Stores, Tiruchirappalli - 620014.	764	60

Buyer Added Bid Specific Terms and Conditions**1. Scope of Supply**

Scope of supply (Bid price to include all cost components) : Only supply of Goods

2. Generic

Bidder shall submit the following documents along with their bid for Vendor Code Creation:

- a. Copy of PAN Card.
- b. Copy of GSTIN.
- c. Copy of Cancelled Cheque.
- d. Copy of EFT Mandate duly certified by Bank.

3. Generic

OPTION CLAUSE: The Purchaser reserves the right to increase or decrease the quantity to be ordered up to 25 percent of bid quantity at the time of placement of contract. The purchaser also reserves the right to increase the ordered quantity by up to 25% of the contracted quantity during the currency of the contract at the contracted rates. Bidders are bound to accept the orders accordingly.

4. Generic

Bidders are advised to check applicable GST on their own before quoting. Buyer will not take any responsibility in this regards. GST reimbursement will be as per actuals or as per applicable rates (whichever is lower), subject to the maximum of quoted GST %.

5. Generic

While generating invoice in GeM portal, the seller must upload scanned copy of GST invoice and the screenshot of GST portal confirming payment of GST.

6. Certificates

Bidder's offer is liable to be rejected if they don't upload any of the certificates / documents sought in the Bid document, ATC and Corrigendum if any.

7. Buyer Added Bid Specific ATC

Buyer uploaded ATC document [Click here to view the file.](#)

Disclaimer

The additional terms and conditions have been incorporated by the Buyer after approval of the Competent Authority in Buyer Organization. Buyer organization is solely responsible for the impact of these clauses on the bidding process, its outcome and consequences thereof including any eccentricity / restriction arising in the bidding process due to these ATCs and due to modification of technical specification and / or terms and conditions governing the bid. Any clause incorporated by the Buyer such as demanding Tender Sample, incorporating any clause against the MSME policy and Preference to make in India Policy, mandating any Brand names or Foreign Certification, changing the default time period for Acceptance of material or payment timeline governed by OM of Department of Expenditure shall be null and void and would not be considered part of bid. Further any reference of conditions published on any external site or reference to external documents / clauses shall also be null and void. If any seller has any objection / grievance against these additional clauses or otherwise on any aspect of this bid, they can raise their representation against the same by using the Representation window provided in the bid details field in Seller dashboard after logging in as a seller within 4 days of bid publication on GeM. Buyer is duty bound to reply to all such representations and would not be allowed to open bids if he fails to reply to such representations.

[This Bid is also governed by the General Terms and Conditions.](#)

In terms of GeM GTC clause 26 regarding Restrictions on procurement from a bidder of a country which shares a land border with India, any bidder from a country which shares a land border with India will be eligible to bid in this tender only if the bidder is registered with the Competent Authority. While participating in bid, Bidder has to undertake compliance of this and any false declaration and non-compliance of this would be a ground for immediate termination of the contract and further legal action in accordance with the laws.

---Thank You---

General terms and conditions on GeM 3.0 (Version 1.21)

1. Introduction

This document is an electronic record published by GeM under the provisions of the Information Technology Act, 2000 and the rules made there under (as applicable) and shall act as valid agreement between Seller / Service Provider and Buyer. Further the use of GeM Portal for Sale / Purchase of Goods / Services and the **resulting Contracts shall be governed by the following General Terms and Conditions (GTC) (unless otherwise superseded by Product / Service specific Special Terms and Conditions (STC), Product / Track / Domain Specific STC of Particular Service including its SLA (Service Level Agreement) and BID/Reverse Auction Specific Additional Terms and Conditions (ATC) as applicable).**

Government e-Marketplace (GeM) is the National Public Procurement Portal; an end-to-end online Marketplace for Central and State Government Ministries / Departments, Central & State Public Sector Undertakings (CPSUs & SPSUs), Autonomous institutions and Local bodies, for procurement of common use goods & services. The portal is owned and managed by GeM SPV which is a Section 8 (Non- Profit) Company registered under the Companies Act, 2013. GeM SPV operates, monitors and supervises all the business transactions on the portal through the Managed Service Provider as per defined roles and responsibilities.

2. General Terms and Definitions:

- a. **“APPLICABLE LAWS”** shall mean any statute, law, ordinance, notification, rule, regulation, judgment, order, decree, bye-law, approval, directive, guideline, policy or other governmental restriction as may be in effect.
- b. **“GOODS”** shall mean an Article / product or an intangible product like software, technology transfer, licenses, patents or other intellectual properties being offered for sale on the GeM portal by Seller(s) on GeM. The term ‘Goods’ shall also include works and services which are incidental or consequential to the supply of such goods, such as, transportation, insurance, installation, commissioning, training and guarantee / warrantee obligations as defined in the scope of supply given in the contract.
- c. **“SERVICES”** shall mean the services offered or provided by the Seller such as IT Professional Services, Manpower Services, Security Services, Transport Services, etc. listed as Services on GeM. The term ‘Service’ shall also include supply of goods / articles which are incidental or consequential to the provisioning of such Services as defined in the scope of supply given in the contract.

- d. **“SERVICE LEVEL AGREEMENT (SLA)”** shall mean the Contractual Commitment that prevails between the Buyer and the Service Provider with regard to type of service to be provided, deliverables, desired performance level, reliability and responsiveness, monitoring process and service level reporting, response and issue resolution time-frame, repercussions / penalties / remedies for service provider not meeting its commitment. The SLA of a particular contract may carry the matrix regarding the delivery of the goods and/or services and the corresponding penalties or remedies and liquidated damages as applicable.
- e. **“CATEGORY SPECIFICATION”** shall mean the framework of technical features, functional capabilities, technical properties, certifications of the items etc. in a particular category. The Specifications shall identify the key parameters defining the products with all necessary validations related to configuration, type of data, restrictions, range / allowed values, allowed units etc. Sellers as well as Buyers while offering / buying the Goods / services shall have to comply with the validation rules / restrictions provided for in the Category Specification. Buyers / Sellers can not add parameters and / or drop down values not provided for in category Specification. If any Buyer / Seller desire to add new parameter, value, validation etc. against any category specification, they have to raise request for the same to GeM for incorporation in Category Specification.
- f. **“BUYER”** is the Contract placing authority, which includes Central/State Government Ministries/Departments including its attached/subordinate offices, Central/State Public Sector Units (PSUs) and Autonomous Bodies acting through its authorized officer(s) for and on behalf of President of India/Governor of the State /PSU/Autonomous Bodies, as the case may be, for purchase of Goods/Services offered by Sellers on GeM.
- g. **“SELLER / SERVICE PROVIDER”** on GeM shall mean any legal entity such as firm(s) of Proprietorship / Partnership Firm / Limited Liability Partnership / Private Limited / Limited company / Society registered under Society’s Act / Statutory Bodies etc., registered on GeM to sell its Good(s) / Service(s) to the Buyers registered on GeM.

The “Seller on GeM” will be either OEM (Original Equipment Manufacturer*) or Seller having authorization to sell products manufactured by the OEM in open market.

* OEM is the owner of the Brand / Trademark of the product being offered or in case of un-registered brand’s products / products with own brand, the actual manufacturer of the final product. To be recognized as an OEM on GeM, seller has to get Vendor Assessment Report from designated agency (unless exempted as per GeM VA policy) as per due process of vendor assessment notified on GeM portal

(which would include production of documentary evidences and demonstration of manufacturing facilities and / or capabilities as required).

In case of Services related to Goods, Service Provider on GeM will be either OEM or Service Provider having authorization to Service products manufactured by that OEM in open market. In respect of other Services, Service Provider on GeM will be any legal entity offering its services.

By registering on GeM portal , Seller / Service Provider hereby agrees to be bound by these General Terms and Conditions for Sale / Purchase of Goods and / or Services (GTC); Product / Service Specific Special Terms and Conditions (STC) and Service Level Agreements (SLAs) for various Services; and Additional (Bid Specific) Terms and Conditions (ATC) as applicable.

For the purpose of this document and transactions on GeM, Seller as well as Service Provider will be referred to as “Seller”

- h. **“USER ID and PASSWORD”** All users including Buyers and Sellers (primary as well as secondary) will get User ID and Password created on GeM following due registration process defined on GeM. It is the responsibility of the user to keep their User ID and Password secure and confidential. Individual user shall be solely and completely responsible for all transactions taking place on GeM portal using his / her User Id and Password and GeM shall not be responsible in any manner.
- i. **“LICENSE”** shall mean by registering the Seller and by offering Product / Service details on GeM, the Seller grants GeM a non-exclusive, royalty-free, irrevocable, perpetual and fully sub-licensable right to use, reproduce, modify, adapt, publish, translate, distribute, and/or display the content/materials which has been submitted to GeM excluding Aadhaar No. In case of registration of Primary user and creation of secondary user(s) by the Buyer/Seller, their Aadhaar (UID) details collected by GeM are solely for user verification and to apply e-signing on the documents. The e-sign is at par with digital signatures as per Information Technology Act Amendment 2008 and it works based on details available in Aadhaar database of UIDAI and there is no interference / intrusion in their personal details.
- j. **“CONTRACT”** shall mean the purchase order created / issued by the Buyer on GeM for supply of Goods / Services in electronic form which includes scope of supply, delivery instructions and specifications etc. as ordered by Buyer against such Contract besides the subject GTC, STC/ATC as the case may be.

3. Role, Responsibilities and Obligations of Seller/ Buyer:

A. Role and Responsibilities of Sellers on GeM are as under:

- i. Only Director (s) / Partner (s) / Proprietor (as applicable) are authorized to become Primary User and register any legal entity on GeM as Seller.
- ii. Once Seller/Service Provider is registered and account is created on GeM, the Primary user of the Seller/Service Provider can create Secondary User Accounts within Seller/Service Provider Organization with different Roles and Responsibilities. However, the Primary User creating Secondary User accounts shall continue to be fully responsible and accountable for all actions / transactions done by Secondary Users on GeM Portal.
- iii. Since GeM is a trust based Portal, the complete accuracy and integrity of data submitted in respect of the Seller and also in respect of the Goods / Services offered on GeM will be the sole responsibility of the Seller/Service Provider. Seller will be liable for administrative action as per GeM terms and conditions in case of any discrepancy / infirmity in any data / information submitted on GeM.
- iv. The Primary / Secondary Users of Sellers, offering Goods/Services and/or participating in e-Bidding / Reverse Auction on GeM, must ensure that they have the requisite authorization to enter into contract with Buyer(s) in GeM for and on behalf of the Seller, failing which such Seller as well as the individual(s) shall be vicariously liable for its actions and also for any liability arising out of such actions.
- v. Seller can offer any number of products. However, it will be the sole responsibility of the seller to satisfy themselves regarding possessing the requisites for doing business for the offered product(s). The Sellers are solely responsible for ensuring that there is no violation of any Intellectual Property Rights in their offer for sell / providing service on GeM.
- vi. The Seller should not exercise any corrupt influence on any aspect of contract and commit to take all measures necessary to prevent corruption maintaining complete transparency, integrity and fairness in all activities related to GeM.
- vii. The seller would represent its business on the GeM portal and is mandated to comply with all the terms and conditions of the platform. Sellers would be solely and absolutely responsible for the information provided about their organization, business, products and services on the portal and would be required to produce proof of such information, if requested at any point in time by the Buyer and / or GeM.

- viii. GeM would not allow creation of any fresh data related to Seller identity on GeM portal. All details provided by the Seller at the time of registration would be counter checked / verified through other data bases of Government such as PAN, MCA 21, Udyam Registration etc. For Financial details, PAN / Income tax Database shall be primary validating database and will override any conflicting data in any other database. If the data / details entered by the seller while registering on GeM is not verified with validating databases, registration will not be allowed. Further, in case of any conflict in details after registration, Seller's registration would be automatically suspended. It is the Seller's responsibility to keep all their information on GeM updated with the latest change(s). Non-updating of details on GeM within 7 days of such occurrence would make Seller liable for administrative actions.
- ix. Eligibility of Sellers in terms of Turn Over / Past Performance / Profitability etc. and also their eligibility for availing various benefits / advantages in terms of various Govt. Policies / Guidelines / Acts / Laws etc. shall be determined solely on the basis of data fetched / validated or verified through external agency / owner of that set of database such as Income Tax / PAN Data Base, MCA 21, Udyam Registration, GSTN, Certifying Agencies such as BIS, BEE etc. In case of any discrepancy in data available in these databases, Seller has to get the same updated in the corresponding validating database before updating the same on GeM. Till such time only the existing validated information shall be used to decide seller's eligibility on GeM. Any default in sellers updating their data on partner sites / validating databases and any fall out of the same impacting adversely any transaction on GeM, shall entirely and exclusively be Seller's responsibility. GeM shall not be responsible for any consequential impact on any GeM transaction due to data discrepancy and / or suspension of seller account due to data discrepancy. Seller will be solely responsible for the same.
- x. The Seller shall be solely responsible for the Goods / Services including, without limitation, the applicable guarantee / warranty, shelf-life, quantity, quality and the title and for giving the correct and accurate details of the offer their Goods and / or /Services indicating product specifications, quantity which can be supplied over the specified time period, etc. as per catalogue or catalogue based template prescribed in GeM. Seller would ensure that the Goods or /Services offered are latest, new and complete in all respects. Where Seller is selling any Goods which needs spare parts, Seller should ensure and make available such spare parts for a minimum period of three years from the date of expiry of warrantee period (unless otherwise specified). The individual Sellers shall ensure that the products offered in e-Bidding and/or ordered shall remain available on GeM during the bid / contract validity period.

- xi. Sellers shall offer minimum discount of 10% on the Maximum Retail Price (MRP) mandatorily (unless otherwise specified for offering their products on GeM). Sellers are free to offer higher discounts. The Seller must offer its best possible lowest price on GeM and undertake that it would not sell or offer to sell the same product outside GeM in comparable quantity on similar terms and conditions at a price equal to or lower than Offer Price on GeM. In case any such infringement by Seller is noticed, the Seller shall be liable to be removed / debarred from the GeM.
- xii. By offering their product on GeM, the Seller agrees for sharing price details of the offered Goods / Service by GeM authorities with other Government agencies including Department of Excise & Customs, Income tax, GST etc.
- xiii. Listing of Goods / Services in irrelevant / inappropriate categories is strictly prohibited. If any such infringement made by Seller leads to placement of a contract by any Buyer for such inappropriately offered product(s)/service(s) by the Seller, such contract shall be treated as null and void. No claim whatsoever against such contract shall be admissible and entertained.
- xiv. The Seller(s) shall pass on all the benefits associated with any scheme / offer / freebies provided by the OEM on any product from time to time on an "as-is basis" to the Buyer. This obligation will also apply to OEM's directly supplying the goods. Holding back any such offer or accounting such freebies in quantity supplied shall make such consignments liable to be rejected by the consignee and shall also be considered as inappropriate and against the GeM policies for which GeM reserves all rights to take necessary action against such Seller/OEM as deemed fit.
- xv. By registering on GeM and by participating in any bid on GeM, Seller undertakes that presently it is not "Debarred from Bidding" on the grounds mentioned in Rule 151 of GFR 2017.

B. Role and Responsibilities of Buyer on GeM:

Buyer Registration on GeM is divided in two categories:

- a. **Primary User:** In GeM, the Primary User is as under:
 - i. Any officer of Central / State Government / PSU / Autonomous Bodies / Local Bodies / Constitutional Bodies / Statuary Bodies at the level of Deputy Secretary of the Government of India or equivalent
 - ii. Head of the Office at Sub Centre / Unit / Branch, can Register his / her organization / unit on GeM portal as Primary User.

Primary User shall be responsible for registering the organization on GeM, for creating User accounts for Secondary Users, assigning them roles and responsibilities on GeM and for supervision of all transactions performed by Secondary Users under him / her.

Primary User shall also be vicariously responsible for ensuring compliance of

General Financial Rules and / or Rules Governing Public Procurement in respect of their organization, all GeM terms and conditions and other Procurement Policies / Guidelines notified by the government from time to time, by all the secondary users including timely payments and for dispute resolutions as per GeM terms and conditions.

Primary user cannot perform any Procurement related transactions on GeM portal.

- b. **Secondary Users:** Secondary Users are officials responsible for procurement transactions on GeM including Placement of Contracts, Receipt of Stores, and Payments to the Sellers etc. The access rights permissible to registered Secondary users would be decided by the Primary User of the Department. Secondary Users may be given the roles of Buyer / Consignee / Drawing and Disbursement Office (DDO) / Paying Authority etc. For transaction on GeM portal, Buyer is the official who is responsible for processing procurement transaction up to Order Placement stage. Consignee is the Secondary User in Buyer Organization responsible for certifying receipt and acceptance of the goods procured.

Buyer's responsibilities on GeM portal are as under:

- i. The Buyers are responsible to ensure that the procurement done by them are in compliance of General Financial Rules and / or Rules Governing Public Procurement in respect of their organization, all GeM terms and conditions and other procurement Policies / Guidelines notified by the government from time to time, including timely payments as per GeM terms and conditions.
- ii. The Buyers (in all capacities i.e. as Buyer, Consignee, DDO, Paying Authority etc) are responsible to ensure that the procurement done by them are in compliance with GeM Terms and Conditions / Guidelines and all contract related transactions are completed within time lines prescribed in GeM Contract.
- iii. The Buyers must ensure that they have the requisite authorization to enter into contract with Seller(s) on GeM for and on behalf of the organization, failing which such individual(s) shall be individually liable for its actions and also for any liability arising out of such actions.
- iv. While making procurement on GeM, the Buyers shall judiciously search and shortlist items using filters such as quantity, technical parameters, delivery period, warranty period, consignee location(s), Seller's eligibility etc. as per their approved requirements. Placement of contract for a product / service uploaded by the Seller in any wrong/inappropriate product category is strictly prohibited and such contracts shall be treated as null and void and such Buying shall adversely affect Buyer Rating on GeM.
- v. The Buyers shall satisfy themselves that the price of the selected offer is reasonable. Buyer is at liberty to utilize all the data / information and Business Analytics made available in GeM including e-bidding and reverse auction.

- vi. The Buyers, before placing the order on GeM, should have the required mandatory approval with prior sanction and approval of the competent authorities and shall be in compliance with and as per procedures outlined in GFR and other procurement guidelines issued by the Government from time to time.
- vii. On award of the Contract(s), it would be construed that the Buyer has obtained all necessary Administrative & Financial sanctions of the competent authority and adequate funds are available indicating the relevant Head of accounts in the awarded Contract(s).
- viii. The Buyers should not exercise any corrupt influence on any aspect of contract and commit to take all measures necessary to prevent corruption maintaining complete transparency and fairness in all activities related to GeM.
- ix. Buyers are not allowed to place any order at GeM prices outside GeM. The prices on GeM are only applicable if the procurement is made through GeM portal. Using GeM prices for procurement outside GeM portal is strictly prohibited. Further, Buyers are not allowed to place any off-line contract to the Seller directly based on the outcome of e-Bidding / RA conducted on GeM. All such contracts shall be treated as null and void and GeM reserves the right to delete all data related to such transactions from GeM database besides taking suitable actions against such Buyers including suspension from GeM and / or reduction of Buyer rating etc.

4. Enabling provisions of Rule 149 of General Financial Rules- 2017

Enabling provisions of Rule 149 of General Financial Rules- 2017 as amended vide Ministry of Finance OM dated 02.04.2019 regarding procurement through GeM and necessary guidelines and terms and conditions thereon:

GeM portal may be utilized by the Government buyers for on-line purchases as under:-

- i. Up to Rs.25,000/- through any of the available suppliers on the GeM, meeting the requisite quality, specification and delivery period.
- ii. Above Rs.25,000/- and up to Rs.5,00,000/- through the GeM Seller having lowest price amongst the available sellers (excluding Automobiles where limit of Rs.30,00,000/- will be applicable), of at least three different manufacturers, on GeM, meeting the requisite quality, specification and delivery period. The tools for online bidding and online reverse auction available on GeM can be used by the Buyer if decided by the competent authority.
- iii. Above Rs.5,00,000/- through the supplier having lowest price meeting the requisite quality, specification and delivery period after mandatorily obtaining bids, using online bidding or reverse auction tool provided on GeM (excluding Automobiles where limit of Rs.30,00,000/- will be applicable).

- iv. The Government Buyers may ascertain the reasonableness of prices before placement of order using the Business Analytics (BA) tools available on GeM including the Last Purchase Price on GeM, Department's own Last Purchase Price etc.
- v. GFR rule 149 allows direct on-line purchases on GeM up to Rs. 25,000/- through any of the available suppliers on the GeM, meeting the requisite quality, specification and delivery period. However this is subject to procuring authorities certifying the reasonability of rates. While making such direct on-line purchase below Rs. 25,000/-, the buyer should have approval of competent authority and should also record reasons for selecting the specific product in case lowest priced products are not being accepted / ordered.
- vi. Tools have been deployed on GeM portal to show the price of compared products on other e-commerce sites (wherever available) and also the rates at which orders have been placed on GeM for such items in recent past. While taking decision on reasonableness of price, the buyers may also take into account the discount over MRP; Last Purchase Price on GeM, Department's own Last Purchase Price; rates on other e-commerce websites etc. The prices on e-commerce site give a broad idea and its terms and conditions may be different. If it is found that the price available on GeM marketplace is not reasonable or is substantially higher than e-commerce sites or LPP, the GeM Portal provides tools for online bidding or reverse auction which can be used by the Buyers to get better competitive rates and then satisfy themselves about reasonableness of the price as per GFR -2017 before placement of contract. Bidding should be considered as the preferred mode of procurement above Rs. 25,000/-.
- vii. In case of Direct Purchase, during carting period, rates for carted quantity, for that buyer, are frozen for carting period as notified from time to time on GeM against any upward revision by seller. However, advantage of any downward revision in the offer price of carted item shall be automatically provided to the buyer.
- viii. According to the provisions of Rule 149 (ii) of GFR, 2017, GeM shall be utilized by Government buyers for direct on-line purchases above Rs. 25,000/- and up to Rs. 5,00,000/- however such purchase has to be through the Seller having the lowest price (L-1) amongst the available Sellers on the GeM. In order to ensure that buyers select only L-1 available offer, the GeM portal enables buyer to first compare all the product options available on GeM to ensure that it meets its requirements/ specifications. While comparing, care should be taken by the Buyer that comparison has to be done between products of at least three different Manufacturers / OEMs. For L-1 buying, comparison has to be made between products of at least three different OEMs, as per GFR. If Buyer wants to buy any specific OEM's product then he has to go for Proprietary Article Certificate (PAC) buying after obtaining necessary approvals of competent

authorities for PAC buying as per GFR-2017, as amended from time to time or the Procurement Guidelines of the respective Organisation as the case may be.

ix. **Proprietary Article Certificate (PAC) Buying:** While making procurement under PAC Buying on GeM, it is the responsibility of the Buyer to ensure that compliances with the conditions / rules as laid down under GFR, 2017, as amended from time to time or the Procurement Guidelines of the respective Organisation as the case may be is met before initiating procurement under PAC:

(a) In case a Govt. Buyer on GeM wants to make procurement on proprietary basis on the GeM Portal after obtaining the requisite approvals / PAC certificate from their competent authority as per Rule 166 of GFR-2017 or the Procurement Guidelines of the respective Organisation as the case may be, the Buyer can use PAC filter provided on GeM for selecting a specific model/ make available from a particular GeM Seller. The Buyer should ensure before procuring the goods under PAC Buying that the Proprietary Article Certificate as per the conditions laid down in GFR or the Procurement Guidelines of the respective Organisation as the case may be is available with the Buyer. It is the responsibility of the Buyer to ensure compliance with GFR or the Procurement Guidelines of the respective Organisation while procuring goods on proprietary basis through the GeM Portal including ensuring the certificate to be in proper format as per GFR or the Procurement Guidelines of the respective Organisation as the case may be.

(b) The Buyer should note that the Seller's price on the Portal is just their offer prices and the proper discovery of price generally happens through bidding/RA. Moreover, in PAC procurement irrespective of multiple listing by authorised sellers, the important issue of price control remaining with the OEM should not be overlooked. Therefore, in case of all the PAC procurements, the Buyers are advised to carry out extra due diligence in establishing the reasonableness of prices before placement of contract as per Para (vii) of Rule -149 of GFR-2017 or the Procurement Guidelines of the respective Organisation as the case may be.

(c) Except for direct buying up to Rs. 25,000/- subject to establishing the reasonableness of price, the bidding is mandatory for procurements above Rs. 25,000/- as per GFR. As result of bidding, the response could be as under:

- i. Only OEM is available or only single authorised seller is available.
- ii. OEM as well as multiple authorised Sellers are available.
- iii. Multiple authorised Sellers of the OEM are available.

(d) After bidding, under PAC buying, the Buyer may take decision with the approval of the competent authority to process the procurement subject to establishing the reasonableness of prices before placement of contract as per Para (vii) of Rule - 149 of GFR-2017 or the Procurement Guidelines of the respective Organisation as the case may be.

- x. In order to give flexibility to the buyers in sourcing their requirements through GeM, provision has been made in e-bid and RA modules for indicating delivery period in terms of “number of days from date of placement of contract”. While stipulating delivery period in their bid documents, Buyers are advised to be careful since un-realistic delivery period stipulations may result in elimination of some genuine sellers, lack of competition and may ultimately have impact on cost of procurement. While fixing delivery period in e-bid/ RA bid, buyers should not only take into consideration the quantity required and the essentiality of requirement of that quantity within stipulated time period but also the possible impact of shorter delivery period on competition in e-bidding / RA.
- xi. Splitting of demands by creating multiple Bids / RAs of same goods / services or making repeated procurements of same Goods / Services through L-1 buying as per rule 149(i) and 149(ii) of GFR-2017 are strictly prohibited on GeM. Splitting of demand deprives the organizations from achieving the best competitive prices leveraging economies of scale. It also implies avoiding the necessity of obtaining the sanction of higher authority required with reference to the estimated value of the total demand. It is a violation of Para Rule 149 (viii) of GFR -2017 and terms and conditions of GeM Portal and Buyer including the Primary Buyer shall be entirely responsible for the same. If any such splitting of demand is noticed, GeM shall have the right to take necessary action such as blocking of such Bids/RAs and / or cancelling such contracts.
- xii. GeM is a dynamic online marketplace. The product/service listings across the existing categories are dynamic. Moreover, new categories of products/services are continuously being added on GeM. In situations where there is only one offer available in a product/ service category and/or there is offer from only one Seller after filter based search, the buyer should not select such offer for buying. Efforts should be made by Buyer to get their past suppliers and prospective Sellers on-boarded on GeM so as to ensure availability of sufficient Sellers on GeM. This however will not apply for PAC procurement.

xiii. e-Bidding and Reverse Auction (RA) on GeM

- (a) The e-Bidding / RA module of GeM is a tool provided to the Buyer(s) for organizing bidding / RA from GeM Sellers of the particular product category for a pre-defined requirement i.e. quantity, technical parameters for Goods/ Services of the particular product category required for one or more Buyers / Consignees.
- (b) Prior to initiating e-Bidding / RA, the Buyer shall judiciously search and shortlist item among the items offered on GeM using filters such as quantity, technical parameters, warranty period, consignee location(s) etc. as per the requirement. In case the search made using actual quantity required, fails to identify sufficient offers, the Buyer may use an indicative quantity for initial search and selection of product and quantity may be

amended to match the actual requirement at the time of finalizing e-Bidding / RA.

- (c) The technical parameters and warranty of the item identified by the Buyer shall be base parameters of the item for conducting e-Bidding / RA for the required Goods/Services.
- (d) The e-Bidding / RA document will be finalized by the Buyer(s) by stipulating requirements such as Quantity, Consignee Details, Terms of Delivery, Delivery Period, EMD, Performance Bank Guarantee, Time & Date for Start and End of Bid Submission and for Opening of Bids and required Bid Validity period etc. GeM system shall decide Start / Reference Price and Step Value of Decrement in case of RA based on product selection and / or outcome of bidding process.
- (e) The e-Bidding / RA invitation / Notice shall be published on GeM, stipulating the last date for bid submission / opening of bids giving at least clear 10 days time after the publication. Any change in last date for bid submission will be intimated to eligible bidders through e-mail / GeM. The e-Bidding invitation shall be extended to all the registered Sellers on GeM who have Goods / Services for that particular category listed on GeM, at least 2 hours prior to closing time of e-Bidding / RA. The GeM normally requires 48 hrs for approval / rejection of the product / service offered by Sellers before it is listed on the portal. Considering these time lines, the Sellers are required to offer their Goods / Services on GeM well in advance before bid closure. The decision of the Buyer/GeM regarding technical/commercial eligibility of the individual Seller to be invited for e-Bidding / RA shall be final.
- (f) The Seller participating in the e-bidding / RA may offer any one of their product(s) already listed on GeM. The bid submitted under e-Bidding / RA shall remain valid for 15 days (or as stipulated by the Buyer in the bid document) from the Bid Opening Date (till 24.00 Hrs IST). Bid Validity can be further extended with mutual consent between Buyer and Seller. The products offered in e-Bidding / RA can not be withdrawn by the Sellers from GeM during the bid validity period. The Buyer reserves the right to postpone/cancel the e-bidding and intimation thereof will be sent by e-mail / GeM to the Bidders. Any amendment / corrigendum to the e-bid invitation issued by the Buyer will be made online and shall be uploaded on the GeM. The participation by the Seller in e-bidding shall be construed as his / her acceptance for all the Terms and Conditions as outlined in the e-bidding including GTC, STC and ATC. However, the Buyer

shall have right to decide the technical and commercial acceptability of the individual bids based on eligibility criteria and compliances as stipulated in the bid document. The technical parameters shown in the bid are from a particular catalogue as selected by the buyer while applying initial filters in selection of the product. The sellers are free to bid for same, equivalent or superior specifications catalogue / products. In the public interest, buyers will evaluate such bids based on their requirements / end use and bid parameters and will accordingly technically accept or reject the bids on merits.

- (g) In bid documents, Buyers can incorporate suitable eligibility criteria and additional terms and conditions only using various filters and ATC module available in e-bidding / RA modules of GeM. Buyers are not allowed to incorporate eligibility criteria and / or additional / special terms and conditions exterior to the GeM portal by making reference to any other website / documents etc.
- (h) In case, two or more acceptable bidders are found to have quoted identical lowest bid price, Buyer has to conduct Reverse Auction for the required Goods among all technically qualified bidders in case of bids for Goods. In case of Services bids, if the multiple L-1 bidders have quoted the lowest allowed price for that service, Buyer shall have two options for placement of Contract:
 - a) Placement of contract by selection of an agency from amongst the L-1 bidders through a Random Algorithm run by GeM system.
 - b) Placement of contract on any one of the L-1 bidders based on any criteria as deemed fit by the Buyer with appropriate internal approvals
- (i) The Buyer reserves the right to accept/reject any bid including the lowest bid received through e-bid and/or annul the e-bidding process.
- (j) The participating bidders shall not disclose details of their bids or other details of their e-bids to other bidders or indulge in any anti-competitive behaviour including price manipulation in violation of Competition Act, 2002.
- (k) The Buyer/GeM will not be held responsible for consequential damages such as no internet connection, no power supply, system problems, loss of electronic information, power interruption etc.
- (l) Against any bidding or RA conducted on GeM, if a bidder quotes Nil Charges/consideration, the bid shall be treated as non-responsive and will not be considered.

(m) There shall be no EMD for Bids / RA having estimated value less than Rs. 5 lakh. For bids / RA having estimated value more than Rs 5 Lakh, while finalizing e-Bid / RA, Buyer shall indicate the exact amount of EMD required to be submitted by bidders in the form of Bank Guarantee on GeM portal in the prescribed format. Scanned copy of the same shall be uploaded by Seller in the online bid and hard copy of the same will have to be submitted directly to the Buyer within 5 days of bid opening. GeM recommends quantum of EMD @ 1% of estimated value of procurement. The Buyer also has the option to select EMD between 0.5% to 5%. The same should be valid for 45 days beyond the bid validity. Following categories of Sellers shall however, be exempted from furnishing EMD:

- i. Micro and Small Enterprises who are manufacturer of the Primary Product Category or Service Provider of the Primary Service Category and give specific confirmation to this effect at the time of bid submission and whose credentials are validated online through Udyam Registration and through uploaded supporting documents.
- ii. Start-ups as recognized by Department of Industrial Policy and Promotion (DIPP).
- iii. KVIC, ACASH , WDO, Coir Board, TRIFED and Kendriya Bhandar.
- iv. Sellers who have got their credentials verified through the process of Vendor Assessment by Vendor Assessment Agencies for the Primary Product / Primary Service for which Bid / RA has been invited.
- v. Sellers/ Service Provider having annual turnover of Rs 500 Crore or more.
- vi. Micro and Small Enterprises registered with NSIC for the Primary Product Category whose credentials are validated through NSIC database and through uploaded supporting documents.
- vii. Micro and Small Enterprises registered with DIC for the Primary Product Category whose credentials are validated through DIC database and through uploaded supporting documents.

- viii. Sellers / Service Providers holding BIS License for the Primary Product Category whose credentials are validated through BIS database and through uploaded supporting documents.
 - ix. Central / State PSUs.
 - x. Seller / Service Provider registered with designated Agency / Authority as specified in the bid document by the Buyer – such bidder shall have to upload scanned copy of relevant registration document in place of EMD document while bidding.
- (n) EMD submitted by the bidder shall be forfeited, if the bidder:
- i. Withdraws or modify or impairs or derogates from the bid in any respect within the period of validity of its bid; or
 - ii. If it comes to notice that the information / documents furnished in its bid is false, misleading or forged; or
 - iii. Fails to furnish requisite performance security / PBG within stipulated time required as per e-bid / RA conditions.
- (o) Notwithstanding above, GeM SPV / GeM Admin also reserve the right to debar such seller from GeM portal. Such debarment shall be for minimum 3 months initially on first such offence and on repeat offence, the debarment period can be increased suitably by GeM SPV / GeM Admin. By submitting a bid on GeM, the Bidder explicitly undertakes to abide by the above clause.
- (p) Earnest money of unsuccessful bidders shall be returned within 15 days after the award of contract or expiry of bid validity whichever is earlier. Earnest money of successful bidder shall be returned within 15 days after receipt of Performance Security / e-PBG.
- (q) In case of RA, Start / Reference Price and Step Value of Decrement shall be indicated to the Bidders at the start of the auction. Any participating bidder can bid one or multiple Step Decrement lower than the prevailing Lowest Bid at that time.
- (r) The Bidder shall be able to view Bid Start Price, Bid Decrement Value, Prevailing Lowest Bid value and last Bid Placed by him. Whenever a lower price bid is received in the closing moment i.e. within 15 minutes of existing end time of Reverse Auction, the end time of reverse auction shall be extended automatically by another 15 minutes. All participant sellers of that RA shall be notified by the GeM system about extension of time through email and/or SMS and they shall be allowed to submit revised bid under the RA. The same process shall be repeated, if there is

another lower bid received in the RA during last 15 minutes of RA.

(s) GeM / Buyer shall not have any liability to bidders for any interruption or delay in access to the GeM site / Reverse Auction link etc, irrespective of the cause.

(t) By creating a bid on GeM, the Buyer undertakes as under:

"I confirm that this tender document complies with the "Public Procurement (Preference to Make in India) Order, 2017, as amended from time to time" issued by DIPP and "Public Procurement Policy for Micro and Small Enterprises (MSEs) Order, 2012, as amended from time to time " issued by MoSME".

(u) **Bid to RA:** While creating bid on GeM, Buyer shall have the provision to select Bid to RA option. If this option is selected by the Buyer at the time of bid creation, Sellers would be required to submit their Technical and Commercial bids before bid closure. After completion of technical evaluation by the Buyer, Reverse Auction would be conducted amongst first 50% of the technically qualified bidders arranged in the order of prices from lowest to highest. Number of sellers eligible for participating in RA would be rounded off to next higher integer value if number of technically qualified bidders is odd (e.g. if 7 bids are technically qualified, then RA will be conducted amongst L-1 to L-4). In case number of technically qualified bidders are 2, RA will be between both without any elimination.

In case Primary products of only one OEM are left in contention for participation in RA based on lowest 50% bidders qualifying for RA, the number of sellers qualifying for RA would be increased to get at least products of one more OEM (directly participated or through its reseller) if available. Further, if bid(s) of any seller(s) eligible for SME preference is / are coming within price band of 15% of L-1 or if bid of any seller(s) eligible for Make in India preference is / are coming within price band of 20% of L-1, then such SME / Make in India seller shall also be allowed to participate in the RA process. After the RA process, the award of contract(s) shall be made by the buyer keeping in view the Public Procurement Policy for Micro and Small Enterprises (MSEs) Order, 2012 and Public Procurement (Preference to Make-in-India) Order, 2017 last revised on 29.5.2019 as amended from time to time.

(v) In case any Seller / Service provider has been debarred in any particular Department / Organization, Buyers of that particular Department / Organization only shall have the right to disqualify

such Sellers / Service providers at the time of technical evaluation of Bids during the period of debarment, subject to the condition that orders of such debarment has been taken with approval of Competent Authority of that Department / Organization and has been communicated to the concerned Seller / Service Provider before bid opening date.

- (w) GeM is an end to end on-line procurement portal and not a tender publishing portal. GeM has detailed GTC, product / service specific STC and a rich ATC library in-built in the portal which can be used to create a comprehensive bid document. Based on the available terms and conditions, there is hardly any need to add any additional conditions to be attached with any GeM bid. However, for inclusion of some clause which is considered absolutely necessary for that particular bid for reasons to be explained in detail, a provision for inclusion of additional conditions in the bid through corrigendum is available in Request Management System. Only indispensable conditions that are not covered in and are not in conflict with GeM GTC, Product / Service STC and the standard ATC library, and which are in compliance with the Govt. orders on Public Procurement and are not restrictive and not against the core principals of transparency, fairness and efficiency enshrined in GeM, can be requested through RMS ATC request for making part of GeM bid through corrigendum. Each such request has to be made only after due approval of the Competent Authority in Buyer Organization confirming that the request has been made with the approval of the Competent Authority. Buyer organization shall be solely responsible for the impact of the requested clauses on the bidding process and its outcome. The clauses which are already covered in standard ATC library available on GeM Portal, will not be allowed through RMS.
- (x) Determination of eligibility in case of products requiring BIS License: In case the bid requires availability of BIS License, bidder has to upload currently valid and operative BIS License copy (Valid on the date of bid opening) to be considered eligible. Submitted BIS License may be in the name of Bidder / OEM or in the name of the Manufacturer to whom the OEM has outsourced manufacturing of his brand of product. The name of the Brand of the offered product should be mentioned in the BIS License. BIS certificate issued under Compulsory registration Scheme for electronic products to OEM/Brand owners for the products marketed under their brand name wherein their products are manufactured at third-party manufacturing unit is valid and is

allowed for participation in the bids floated on GeM. The Manufacturer's Authorization in all such cases wherein the manufacturing is done by a third party shall be issued by the Brand owner / OEM and not by the third-party manufacturing unit mentioned in the BIS certificate.

- (y) **Bid Splitting:** In case of critical / vital / safety / security nature of the item, and / or large quantity under procurement and / or urgent delivery requirements and / or inadequate vendor capacity, Buyer may decide to have more than one source of supply. In such cases Buyer may opt for Bid Splitting while creating the bid on GeM, clearly indicating the Bid Splitting ratio in which order will be split among L-1, L-2, L-3 etc as per ratio of splitting pre-disclosed in the bid . After technical and financial evaluation, before splitting the quantity, it should be ensured by the Buyer that the L1 price is reasonable. After deciding the acceptable reasonable price, L1 would be awarded contract for at least the first / highest percentage indicated in the bid splitting ratio. For the rest of the bid quantity, the L-1 rates / lowest accepted rate will be counter offered to the next higher quoting bidder(s) for price matching. On acceptance of the counter offer, the order will be placed on next higher quoting bidder(s) for the respective percentage. In case of non- acceptance of the counter offer by the next higher quoting bidder(s), a similar offer shall be made to L3 and L4, and so on. In case counter offered rates are not accepted for ratio of splitting quantity as per bid document by any of the subsequent bidders, the left over quantity will be divided between bidders who have accepted the rates in the ratio of their originally allocated quantities subject to their confirmation and after getting consent on mutually agreed delivery schedule for the additional quantity.

5. Contract(s):

Following documents shall be construed to be part of the contract generated through GeM:

- i. Scope of supply including price as enumerated in the Contract Document.
- ii. General Terms and Conditions (GTC).
- iii. Product / Service specific Special Terms and Conditions (STC).
- iv. Product / Track / Domain Specific STC of Particular Service including its SLA (Service Level Agreement)
- v. Bid / RA specific Additional Terms and Conditions (ATC).

The Terms and Conditions stipulated in STC & SLA will supersede those in GTC and Terms and Conditions stipulated in ATC will supersede those in GTC and STC in case of any conflicting provisions.

6. Prices:

- i. **Offer price on GeM portal:** The prices of the offered Goods or Services shall be firm and fixed at any point of time and shall be indicated in INR for each accounting unit. The Seller can choose to offer Goods or Services with uniform all inclusive unit price for deliveries at locations across India on All India basis or for specified locations selected at the time of product listing. As such, for supply of Goods contract, no additional charges such as local levies / transportation / loading unloading charges etc., shall be payable over and above the contract price. For selected freight intensive products, as notified on GeM, the Seller may quote unit price inclusive of GST with delivery charge(s) (including transportation, loading unloading and local levies) payable extra as defined in the relevant categories. In respect of items requiring installation and / or commissioning and other services (as indicated in technical details of the item), the charges for the same shall also be included in the offered price on GeM.

Once a Buyer carts a particular quantity of offered Goods / Service, during carting period as notified from time to time on GeM, rates for carted quantity, for that buyer, are frozen for the period as specified on the portal against any upward revision by seller. However, advantage of any downward revision in the offer price of carted item shall be automatically provided to the buyer.

- ii. **Offer price in e-bidding:** Bidder is required to indicate offer price in the price schedule as provided in the bidding document. Complete breakup of price as required must be indicated. However evaluation of the bid shall be on the basis of total all inclusive, landed price at consignee destination (unless otherwise specified in the ATC).
- iii. **Offer price in RA:** Bidder is required to indicate total offer price. Evaluation of the bid shall be on the basis of total all inclusive, landed price at consignee destination (unless otherwise specified in the ATC). Successful bidder shall have to provide complete breakup of the quoted price in the required price bid format before award of contract.

7. Performance Security and Performance:

- i. *There shall be no Performance security / PBG requirement for contracts:*
 - a) *Placed under Direct Purchase / L-1 Purchase Option under Para (i) and (ii) of GFR rule 149;*
 - b) *Placed through Bids / RA with estimated bid value up to Rs 5 Lakh (in case of Goods contracts); and*
 - c) *Placed through Bids / RA with estimated bid value up to Rs 5 Lakh (in*

case of Services contracts)

- ii. In case of contracts placed following e-Bidding / RA, Performance Security / Performance Bank Guarantee (PBG) (in format provided on GeM) valid for 2 months beyond the date of completion of all contractual obligations including warrantee obligations, will be obtained from the successful Bidder, for ensuring due performance of the contract. GeM recommends quantum of Performance Security @ 2% of the value of contract. The Buyer also has the option to select Performance Security between 2% to 10%. While finalizing e-Bid / RA, Buyer shall indicate the % of Performance Security required to be submitted by successful bidders. In case of any extension of contract obligation period, the seller shall be liable to suitably extend the validity of the Performance Security.

Such Performance Bank Guarantee, in prescribed format, from a scheduled commercial bank must be submitted by Seller to the Buyer within 15 days of award of contract on GeM. The payments to the seller shall become due only after receipt of Performance Bank Guarantee by the Buyer and verification of its genuineness.

If the Seller fails or neglects to observe or perform any of his obligations under the contract it shall be lawful for the Buyer to forfeit either in whole or in part, the Performance Security furnished by the Seller.

If the Seller duly performs and completes the contract in all respects the Buyer shall, refund the Performance Security to the Seller within 30 days of completion of all contractual obligations by the Seller.

8. Duties & Taxes:

- i. Offer Prices on GeM shall be on all inclusive basis i.e. including all taxes, duties, local levies / transportation / loading-unloading charges etc. In the case of Bid / RA, complete break-up of the quoted price in the required price bid format shall be furnished by the Bidder, before award of contract.
- ii. Statutory variation in the rate of GST, taking place between the date of award of contract and the original / refixed delivery period, shall be to the Buyer's account. For claiming any change in price due to such Statutory variation, the seller shall have to lodge claim before the Buyer providing documentary evidence of change in rate of GST taking place after the date of award of contract and the date of supply within the original / refixed delivery period. Buyer shall issue necessary amendment in the contract to enable generation of supplementary invoice or revised invoice as the case may be.
- iii. No increase in price on account of statutory increase in the rate of GST taking place during the period of delivery period extension with liquidated Damages shall be admissible. Nevertheless the Buyer shall be entitled to the benefit of any decrease in price on account of reduction in GST taking place during extended delivery period.

- iv. The Bill Form / On-line invoice shall be generated by the Seller which may inter-alia include the following confirmations from the Seller:
- a. Certified that the Goods and Services Tax (GST) charged on this Bill is not more than what is payable under the provision of the relevant Act or the Rules made there under.
 - b. Certified that the goods on which GST has been charged have not been exempted under the GST Act or the rules made there under and the charges on account of GST on these goods are correct under the provisions of that Act or the Rules made there under.
 - c. Certified that the Seller is registered with above indicated GSTIN as dealer in the State where in their Billing address is located for the purpose of GST.
 - d. The on-line bill form / invoice generated on GeM is not a replacement for the GST invoice. The proper GST invoice as per requirements of GST rules shall be sent by the seller to the buyer / consignee directly along with the Goods / Services as and when deliveries are made to the consignee.
- v. Seller shall comply with all the necessary statutory compliances including but not limited to providing GST invoices or other documentation as per GST Law relating to the supply of Goods or Services, uploading the details of the invoices, payment of taxes, timely filing of valid statutory returns for the tax period in the GST portal. In case the Input Tax Credit of GST is denied or demand is recovered from Buyer on account of any act/ omission of the Seller in this regard, the Seller shall be liable in respect of all claims of tax, penalty and / or interest, loss, damages, costs, expenses and liability that may arise due to such non-compliance. Buyer shall have the right to recover such amount from any payments due to the Seller or from Performance Security, or any other legal recourse from the said Seller. If any tax is required to be paid by the Seller in pursuance of any demand from tax authorities, on account of Seller's suppression of facts, fraud or wilful misstatement of facts while offering the products or submitting the bids, then the same shall not be passed on to Buyer through debit notes or Invoices or Supplementary Invoices and the seller shall be solely liable for payment of the same.

9. Integrity Pact:

All the Users in GeM i.e. Seller as well as Buyer agree not to indulge in any corrupt practices including without limitation any activity or action to influence the transaction on any aspect of contract and commit to take all measures necessary to prevent corruption maintaining complete transparency and fairness in all activities related to GeM. Users agree to follow and adhere with the Integrity Pact guidelines provided on GeM Portal.

10. Guarantee And Warrantee:

- i. The Goods/Services supplied under the Contract(s) shall be in accordance with the contract specifications & quality and the Goods shall be brand new and have standard Guarantee/Warrantee for one year period from the date of final acceptance by the consignee unless otherwise specified in category specifications, specific Bid/RA . Seller, at the time of listing their product on GeM portal or offering their products against any Bid / RA, may accordingly provide longer Guarantee/Warrantee period (i.e. more than 1 year) and in such case, Guarantee/Warrantee period stipulation made in category specifications / Bid / RA document, shall prevail over standard Guarantee / Warrantee period of 1 year stipulated in these General Terms and Conditions.
- ii. Notwithstanding the fact that the Buyer or its Quality Assurance Officer may have inspected and/or approved / accepted the said Goods, it is further guaranteed that if during the said guarantee / warrantee period, the Goods be discovered not to conform to the requisite description and quality and/or not giving satisfactory performance or have deteriorated, and the decision of the Buyer in that behalf shall be final and binding on the Seller and the Buyer shall be entitled to call upon the Seller to rectify and/or replace the Goods or such portion thereof as is found to be defective by the Buyer within 7 days. Otherwise, the Seller shall pay to the Buyer such compensations that may arise by reasons of the warranty therein contained. In cases requiring Spares, the Seller guarantees that they will supply Spare Parts, if and when required on agreed basis for an agreed price for a minimum period of three years from the date of expiry of warrantee period (unless otherwise specified in STC / ATC). The agreed basis could be, including but without any limitation, an agreed discount on the published catalogue or an agreed percentage of profit on the landed cost. The aforesaid provisions made specifically for Goods, shall also be applicable for Services to the extent the same are practically possible.

11. Buyer / Consignee's Right Of Rejection (Return Policy):

- i. The Goods delivered shall bear the self certified Manufacturer's/Seller's Warranty/Guaranty. Buyer / Consignee shall have the right to inspect the supplied Goods themselves and/or through their appointed agency at consignee's own cost, at Consignee's site(s) after receipt and accept or reject on proper justification any consignment of the Goods received within a period of 10 days (unless otherwise specified in STC or ATC) of receipt of consignment of goods. The date of receipt shall be reckoned from the date of receipt of the Goods as notified in the Provisional Receipt Certificate (PRC) which will be issued online by consignee immediately after receipt of Goods.
- ii. In case of Service contract, the Buyer reserves right to reject the same in conformance with the terms and conditions of the agreed Service Level Agreement

(SLA). However, such right to reject services offered by the Seller under the contract shall be exercised by the Buyer within 10 days (unless otherwise specified in STC or ATC) of the date of receipt of the Service. The date & time of start and completion of the Service, shall be indicated by the Seller while raising on-line invoice for a specified period of Service as per Service Level Agreement (SLA). The date of such invoice or the date of completion of the service, whichever is later shall be reckoned as date of receipt of the Service.

- iii. On Acceptance / Part Acceptance or Rejection of Goods / Services, Consignee will issue an on line 'Consignee's Receipt cum Acceptance Certificate' (CRAC), which will form the basis of Payments to the Seller.
- iv. No payment shall be made for rejected goods or services. After intimation of the rejection / part rejection by the Buyer/ Consignee, the Seller shall be liable to remove / lift back such rejected Goods within 10 days without any extra charge/cost to the Buyer / Consignee failing which suitable ground rent / warehousing charges would be payable by the Seller to the Buyer /Consignee.If the Seller fails to remove / lift back such rejected Goods within reasonable time period, the Buyer / Consignee shall have the right to dispose off such rejected goods at the risk and cost of the seller.

12. Payment Authority and Payment Terms:

Payments shall be made to the Seller in the manner below:

i. For Goods :

In case of goods, 100% payment will be released within ten (10) days of issue of consignee receipt-cum-acceptance certificate (CRAC) and on-line submission of bills unless otherwise specified in STC / ATC.

ii. For Services:

In case of services, 100% payments on the basis of monthly (unless otherwise specified) bills will be paid within ten (10) days of issue of consignee receipt- cum-acceptance certificate (CRAC) and on-line submission of bills unless otherwise specified in STC / ATC.

13. Terms of Delivery:

All the Goods or Services in the GeM shall be offered on Free Delivery at Site basis including loading/unloading. In respect of items requiring installation, commissioning and other services in the scope of supply (as indicated in respective product category specification / STC / ATC), the cost of the same shall also be included in the offer price.

14. Delivery Period

Seller shall indicate the quantity which can be supplied over the specified time period(s). The Seller would offer these details, which would constitute the part of the awarded Contract(s) in the GeM and would make a binding Contract between the Seller & the Buyer. Any modification thereto shall be mutually agreed and incorporated in the Contract. This Delivery Period/Time shall be deemed to be essence of the Contract and delivery must be completed not later than such date(s).

15. Extension of Delivery Period and Liquidated Damages:

Buyer may, on the request of the Seller or otherwise, extend the delivery date suitably subject to the following conditions:

- i. The original Delivery Period may be re-fixed by the Buyer without any Liquidated damages subject to Force Majeure conditions mentioned below and also on the ground/reasons of delay attributable to the Buyer / Consignee.
- ii. For other cases, provided the price trend is not lower, the Delivery Period may be suitably extended for which an amount equal to the Liquidated Damages for the extended period(s) for delay in the supply of the Goods/Services after the expiry of contract delivery period /re-fixed delivery period, shall be recovered from the Seller as mentioned hereinafter for the extended period.No increase in price on any ground after the original/re-fixed delivery date shall be admissible during such extended period(s). Nevertheless the Buyer shall be entitled to the benefit of any decrease in price on account of reduction in GST taking place during extended delivery period.
- iii. **Liquidated Damages:** If the Seller/Service Provider fails to deliver any or all of the Goods/Services within the original/re-fixed delivery period(s) specified in the contract, the Buyer will be entitled to deduct/recover the Liquidated Damages for the delay, unless covered under Force Majeure conditions aforesaid, @ 0.5% of the contract value of delayed quantity per week or part of the week of delayed period as pre-estimated damages not exceeding 10% of the contract value of delayed quantity without any controversy/dispute of any sort whatsoever.
- iv. **Force Majeure Conditions :**

If at any time during the continuance of the Contract, the performance in whole or in part by either party of any obligation under this Contract shall be prevented or delayed by the reasons of any war, hostility, acts of the public enemy, epidemics, civil commotion, sabotage, fires, floods, explosion, quarantine restrictions, strikes, lockouts or act of God provided notice of happening of such event duly evidenced with documents is given by one party to the other within 10 days from the date of occurrence thereof, neither party shall be by reasons of such event, be entitled to terminate the Contract nor shall either party have any claim for damages against the other in respect of such non-performance or the delay in performance, and deliveries under the contract shall be resumed as

soon as practicable after such event has come to an end or ceased to exist, and the decision of the Buyer as to whether the deliveries have been so resumed or not, shall be final and conclusive, Provided further that if the performance in whole or part of any obligation under this contract is prevented or delayed by reason of any such event for a period exceeding **10 days**, either party may at its option terminate the contract provided also that the Buyer shall be at liberty to take over from the Seller at a price to be fixed by Buyer, which shall be final, all unused, undamaged and accepted material, bought out components and Goods in course of manufacture in the possession of the Seller at the time of such termination or such portion thereof as the Buyer may deem fit excepting such materials, bought out components and Goods as the Seller may with the concurrence of the Buyer elect to retain.

16. DISPUTE RESOLUTION BETWEEN THE BUYER AND THE SELLER / SERVICE PROVIDER

16.1 AMICABLE SETTLEMENT:

- i. The Parties (i.e., the Buyer and the Seller/ Service Provider) undertake that any conflict or dispute that may arise between them shall first be dealt with in the manner stated below, irrespective of any other recourse, which any Party may have in law or in equity.
- ii. In the event of any conflict or dispute arising out of or in connection with the Contract placed through GeM, the Parties shall endeavor to settle such disputes amicably. If a dispute is not resolved within 30 (thirty) days after a written notice of any dispute by one Party to the other, the same shall then be resolved through the mechanism of a Dispute Resolution Committee. This Dispute Resolution Committee shall comprise of representatives of both the Buyer and the Seller / Service Provider and shall be chaired by the Primary User of the Buyer organization/department or any other person as authorized by the Primary User. If the Dispute Resolution Committee is not able to resolve the matter within 30(thirty) days of its formation, the dispute shall then be referred to Arbitration.

16.2 ARBITRATION:

In the event of any conflict / dispute arising out of or in connection with the Contract placed through GeM, which has not been resolved in accordance with the procedure laid down in Clause 16.1 above, the aggrieved Party may invoke Arbitration by sending a written notice to the other Party. The procedure for appointment of the Arbitral Tribunal shall be as follows.

- i. In cases where the total value of the Contract is less than INR 1,00,00,000/- (Indian Rupees One Crore only) the same shall be referred to a sole arbitrator mutually appointed by both the Parties.
- ii. Where the total value of the Contract exceeds INR 1,00,00,000/- (Indian Rupees One Crore only), the arbitration shall be conducted by a quorum of three arbitrators. Each party shall be entitled to appoint an arbitrator and the two party-appointed arbitrators shall within 30 (thirty) days from their nomination, appoint a third arbitrator i.e., the Presiding Arbitrator.

- iii. In case of failure to appoint the Presiding Arbitrator within a period of 30 (thirty) days from the date of nomination of the two arbitrators by the respective parties, the aggrieved party shall approach the High Court (under whose jurisdiction the principal place of business of the Buyer department/ organization is located) to appoint the Presiding Arbitrator as per the provisions of the Arbitration and Conciliation Act, 1996 (as amended up to date).
 - iv. The arbitration shall be conducted in the English language. Arbitration proceedings can also be conducted online, as per the discretion of the Arbitral Tribunal.
 - v. The cost of the Arbitration shall be equally borne by both the Parties.
 - vi. The award of the arbitrator shall be final and binding on the Parties to the Contract. The arbitration shall be governed by the Arbitration and Conciliation Act, 1996, as amended up to date. The seat of arbitration shall be at the place where the principal place of business of the Buyer department / organization is located.
 - vii. The Contract shall be interpreted and governed in all respects in accordance with the laws of India. All disputes in connection with or arising out of the Contract, shall be subject to the exclusive jurisdiction of the Court within the local limits of whose jurisdiction principal place of business of the Buyer department / organization is located.
- 16.3** Both the Parties understand and agree that GeM being an Intermediary cannot be made a party to any dispute in connection with or arising out of the Contract and/or the arbitration proceedings between the Parties

17. Laws Governing the Contract:

- i. The contract shall be governed by the laws of India for the time being in force.
- ii. Irrespective of the place of delivery, the place of performance or the place of payment under the contract, the contract shall be deemed to have been made at the registered address of the Buyer and / or Primary Buyer.
- iii. Jurisdiction of Courts: The courts of the place from where the contract has been made shall alone have jurisdiction to decide any dispute arising out of or in respect of the contract.
- iv. GeM SPV would not be a party to any such litigation.
- v. In case any Seller / Service provider makes GeM a party / respondent in any case involving any dispute between Buyer and Seller arising out of a concluded contract or arising out of bidding process initiated / concluded by the Buyer on GeM, it would be obligatory on the part of the Buyer to represent GeM also through their Counsel / Lawyer in the proceedings before the legal authority and ensure timely filing of replies / affidavits etc provided by GeM also through their Counsel / Lawyer before the concerned legal authority during the course of litigation. A standard reply on behalf of GeM, covering following aspects shall be incorporated in all replies / affidavits filed by the Buyer in such cases:

“Government e-Marketplace is a National Public Procurement Portal; an end-to-end online Marketplace for Central and State Government Ministries / Departments, Central & State Public Sector Undertakings (CPSUs & SPSUs), Autonomous institutions and Local bodies, for procurement of common use goods & services. Prima facie, the dispute in the present case appears to be between the Buyer and Seller arising out a contract placed / bid created by the Buyer on Government e-Marketplace. As per Clause 16, Clause 17 and Clause 22 of the General Terms and Conditions of Government e-Marketplace (duly accepted by the Buyer and Seller), GeM is not to be made a party to any dispute between the Buyer and the Seller. As such Government e-Marketplace is liable to be deleted from the array of parties.

In light of the above, we request your goodself to kindly delete Government e-Marketplace from the array of parties.”

18. Limitation of Liability:

Notwithstanding anything contained in this agreement, no party will be liable for any special, incidental or consequential damages arising out of or in connection with this agreement or any breach hereof (including for loss of data or profits, or cost of cover), whether or not such party has been advised of the possibility of such damages, and whether under a theory of contract, tort (including negligence) or otherwise; except for liabilities arising out of any violation, misappropriation or infringement of a party’s intellectual property rights, or from a breach by either party of its obligation. In no event will either party’s aggregate liability arising out of or in connection with this agreement or any breach hereof (whether under a theory of contract, tort (including negligence), warranty or otherwise) exceed the Contract Price entered into the Contract between Buyer and Seller.

19. Termination for Default:

If the Seller does not perform its obligations within the Delivery Period/Date mentioned in the Contract, the same would constitute the breach of the Contract and the Buyer shall have the right to Cancel or withdraw the Contract for the unsupplied portion after the expiry of the original or re-fixed delivery date or period stipulated in the Contract. Such cancellation of contract on account of non - performance by the Seller would entitle the Buyer to forfeit the performance security besides other actions such as downgrading the Seller’s rating or debarment from the GeM for specified period as decided by GeM on merits.

20. Closure of Transaction:

After satisfactory completion of all the obligations under the Contract and release of payments for the goods / services, the transaction shall be treated as closed.

21. Grounds for Administrative Action

(i) Administrative actions may be taken by GeM against the Buyer or the Seller either suo-moto on the basis of the platform mechanisms identified through analytics or on the basis of a complaint or report made to GeM by any stakeholders or any third party information or upon Court order, inter –alia, for non-adherence to the GeM Website Policies including Terms and Conditions and the Incident Management Policy published on the GeM Website.

(ii) The Seller would be liable for administrative actions such as suspension / debarment / removal from GeM, if they fail to abide by any of the Website Policies including the terms & conditions stipulated in this document and/or on anyone or more of the following grounds:

- (a) Listing the products/services not in the relevant categories and/or listing the same with vague/conflicting product specifications/details and irrelevant product photographs.
 - (b) Offering Goods / Services without having proper authorization
 - (c) Supplies goods of inferior/ substandard quality
 - (d) Supplies or offers to supply refurbished or counterfeit or fake products
 - (e) Withdraws or modify or impairs or derogates from the bid in any respect within the period of validity of its bid;
 - (f) Seller furnishes inaccurate, false, misleading or forged or fails to furnish any information / documents, within the prescribed time limits, to GeM or to a Buyer, including during e-Bidding/RA process;
 - (g) Fails to furnish requisite performance security / PBG within stipulated time required as per e-bid / RA conditions;
 - (h) Fails to update GeM about any change in information furnished within the prescribed time limits;
 - (i) Executes services without conforming to requirement given in Service Level Agreement (SLA);
 - (j) Fails to execute an order/ contract or fail to execute it satisfactorily
 - (k) Is declared bankrupt or insolvent;
 - (l) Fails to produce the requisite documents/ information during the course of inspection / assessment at any stage;
 - (m) Performs any activity which is listed as prohibited activities on GeM.
 - (n) On any other ground for which, in the opinion of GeM, the retention of the seller or any of its offered product in GeM is not in Public Interest.
 - (o) The grounds mentioned above are illustrative only. Users are also advised to read the list of prohibited activities published on the website.
- (iii) Notwithstanding anything contained in the GTC, GeM reserves the right to cancel or annul the registration of any Seller or remove any of the Good/Services listed by a Seller on the GeM Website to comply with

- any provision of the Applicable Laws and / or Court Orders.
- (iv) GeM may take an administrative action in terms of the GeM Website Policies against a Buyer which may include reporting of any breach or misconduct to the Buyer Primary User and/or to the competent authority and GeM reserves the right to review the rating of such Buyer, and / or block Buyer's account for such time as considered appropriate by GeM.
 - (v) The Seller and the Buyer understands that the grounds for administrative action as provided under the Contract are only indicative and additional grounds may be provided under the GeM Website Policies including the Incident Management policy. The Seller / Buyer warrants to abide by all additional grounds as may be specified by GeM in the GeM Website Policies from time to time.

22. Role of Government E- Marketplace - Gem SPV

Government e-Marketplace – GeM SPV is the owner of the GeM portal which monitors and supervises all the business transactions on the portal. The role and responsibilities of the company are as under:

- 22.1** To develop, operate and maintain technology driven e-marketplace, through a Managed Service Provider (MSP), to be used by government agencies for procurement of various goods and services in a transparent and efficient manner.
- 22.2** Overall supervision and monitoring of GeM portal operations, policy management, finalization and implementation of various business processes and work flows in adherence with the applicable law and executive orders issued from time to time . To provide tools for on-line Bidding, on-line Reverse Auction and Business Analytics Tools on GeM.
- 22.3** To work continuously for improvements in the Business Processes and Work Flows for various activities / functions on GeM based on feedback from various stakeholders to enhance transparency, efficiency, competitiveness, equality, economy in procurement of goods and services by government agencies.
- 22.4** To finalize General Terms and Conditions for sale and purchase of Goods and Services on GeM, Product / Service Specific Special Terms and Conditions, Special Terms and Conditions for Bunching of Goods / Services, Bid Specific Special Conditions, Project Specific Special Conditions etc.
- 22.5** To finalize, upload and approve Technical Specification Frameworks for various item / service categories on GeM and to monitor conformity of offered products to the larger framework so finalized and uploaded.
- 22.6** To decide addition / deletion of any of the offered product(s)/Product category (ies) and their framework of technical parameters on GeM.
- 22.7** To work and co-ordinate with different Organizations/Departments / Agencies for integration of their Databases with the GeM portal on real time basis for the purpose of verification/authentication of data entries made by stakeholders.

- 22.8 To offer and manage Demand Aggregation services for identified categories across buyers with assured reasonability of price, recommending for placement of orders by individual buyers
- 22.9 To co-ordinate with MSP for conducting workshops for the various Stakeholders in capacity building and in change management associated with the implementation of technology enabled procurement process.
- 22.10 To monitor MSP that the Buyers, Sellers and Service Providers are being assisted properly by them to onboard their goods and services on the GeM platform.
- 22.11 To identify and offer services of 3rd parties for Vendor Assessment relating to technical, financial capacity, past experience of sellers including manufacturing / testing facilities / quality control arrangement(s) of manufacturing premises and/or any of the premises related to manufacturing process of products / services offered by the seller / service provider on GeM.
- 22.12 To identify and offer services of 3rd parties for testing and certifying the quality of the product offered/ supplied, through documents, test reports/ certificates, testing at any independent lab or through inspection/testing by its authorized representative/s at firm's premises or at user's premises, that buyer choose to use.
- 22.13 Overall monitoring and management of Call Centre/Help desk operations being provided by the MSP.
- 22.14 Removal / debarring the Sellers/Buyers and Goods / services in GeM.
- 22.15 Management of complaints and their redressal mechanism in GeM (not disputes related to concluded contracts).
- 22.16 To identify, integrate and manage MoUs with verifying, certifying and validating entities across government(s) and also professional agencies to reinforce the online paperless, contactless and cashless system on GeM.
- 22.17 To issue Notices, Circulars, News, Flashes, Updates etc in GeM
- 22.18 Reporting and MIS mechanism in GeM
- 22.19 Any other related activities in the GeM
- 22.20 In exceptional circumstances, for ensuring propriety of procurement processes or to obviate possible misuse of GeM functionalities, GeM SPV as GeM Admin may keep any Bidding / RA process on hold for some time as considered appropriate.
- 22.21 To take approved User Charges from Buyers and Sellers for the various transactions on the GeM portal as decided and notified on the GeM portal.

23. Miscellaneous Provisions

- 23.1 Assignment:** Users understand and agree that the GTC, STC and ATC provisions, rights and obligations granted by GeM are non- transferrable or assignable by the User to any third party, without the prior written consent of GeM.

If same is permitted by GeM, all the conditions, rights and obligations of the GTC or any on-going STC/ATC shall also be binding upon such third party assignee besides the User.

23.2 Indemnification: The Seller shall at all time indemnify Buyer against all suits and claims which may be made in respect of the goods/services for infringement of any right protected by patent, registration of designs or trade mark. Provided always that in the event of any claim and suit in respect of alleged breach of patent, registered designs or trade-mark being made against the Buyer, the Buyer shall notify the Seller/ Service Provider of the same who shall at its own expense either settle any such dispute or conduct and litigation that may arise there from.

Buyers and Sellers agree to indemnify, defend and hold harmless GeM, its officials, Managed Service Provider (herein after individually and collectively referred to as "indemnified parties") from and against any and all losses, liabilities, claims, suits, proceedings, penalties, interests, damages, demands, costs and expenses (including legal and other statutory fees and disbursements in connection therewith and interest chargeable thereon) asserted against or incurred by the indemnified parties that arise out of, result from, or in connection with

- 23.2.1 Breach of the contract(s); or
- 23.2.2 Any claims made by any third party due to, or arising out of, or in connection with, use of the Website; or
- 23.2.3 Any claim made by any third party regarding content/ information or materials provided by Seller cause any damage to a third party; or arising out of, or in connection with, use of the Website.
- 23.2.4 Violation of any intellectual property rights or any other rights.

Once GeM notifies the Buyer/ Seller of such claims, they shall defend and indemnify GeM for the same. Further, in no case they shall compromise or settle any claim or admit any liability on the part of GeM without the express or prior written consent of GeM which can be withheld or denied or modified by GeM in its sole discretion or as per the Applicable Laws.

23.3 Severability: If due to any change in Applicable laws, certain part of the GTC or any applicable STC or any provisions of the GeM policies or portions thereof, becomes unenforceable, the remaining provisions shall continue in full force and effect so as to give effect to the intent of the parties.

23.4 Website Terms and Policies Updation: Buyers and Sellers are advised to check the website terms and conditions as well as policies such as Privacy Policy and the Website Disclaimer at all times, as GeM may update the Website and such terms from time to time.

23.5 List of Prohibitive Activities (Suggestive And Non-Exhaustive):

LIST OF PROHIBITIVE ACTIVITIES: The following is an indicative list of prohibitive activities which the Buyers and the Sellers registered on GeM platform shall not perform on the GeM platform. A breach of any of the prohibited activities shall give the right to GeM under the Applicable Laws or in terms of these GTC or the GeM Website Policies to take administrative action which may include partial or permanent disabling of account on GeM Website, debarment etc. Additionally, GeM may remove any non-compliant information and reserves the right to preserve and share with the appropriate authority such information and associated records for investigation purposes. The Buyer and the Seller understand that this list is only indicative and additional activities may be prohibited under the GeM Website Policies. The Buyers and the Sellers shall undertake to provide their full support that may be required by GeM for removal and disabling of the non compliant information. The prohibited activities include:

- (i) Indulging in cyber crime or other criminal activities which can become a threat to GeM, GeM Website, to the Government of India or to any State Government or Government Agency.
- (ii) Advertising, exhibiting, representing, publishing, pronouncing, listing, delivering, offering to sell or selling any kind of Goods/Services which can cause any kind of infringement or disparagement of intellectual property rights.
- (iii) Selling refurbished, counterfeit and/or fake Goods / Services under a brand or misusing others brand name.
- (iv) Offering to sell or selling above the MRP any Goods or misrepresenting the MRP.
- (v) Delivering some other Goods or Services instead of the Goods or Services Contracted for or delivering empty parcels or used Goods in breach of the terms of the Contract.
- (vi) Offering to sell or selling freebies which are 'Not for sale' Goods.
- (vii) Listing of the Goods on GeM Website without authorization to sell Goods manufactured by the OEM in open market or without proper authorisation, if any required, for providing the Service.
- (viii) Listing of the Goods or Services is done on GeM Website without guarantee/warranty or without a genuine guarantee/warranty.
- (ix) Listing of the Goods or Services in irrelevant or inappropriate categories or with vague or conflicting specifications or description (including descriptive or pictorial description).

- (x) The Buyer /Seller registering on GeM and/or offering or buying the Goods and/or Services and/or participating in e-bidding/reverse auction on GeM, without the requisite authorization to enter into contract on behalf of the concerned legal entity. Failing which such individual(s) shall be individually liable for its actions and also for any liability arising out of such actions.
- (xi) If any Seller has been debarred from GeM then such Seller or their authorized sellers shall also not be permitted to register and offer/sell their products on GeM and / or participate in Bids / RA on GeM.
- (xii) Using GeM prices for making procurement outside GeM Portal.
- (xiii) Splitting of demands by creating multiple Bids/RAs of same goods / services or making repeated procurements of same goods/services through Direct Purchase / L-1 buying as per rule 149(i) and 9(ii) of GFR- 2017.
- (xiv) Uploading goods / services containing information that —
 - (a) belongs to another person and to which the user does not have any right to;
 - (b) is grossly harmful, harassing, blasphemous, defamatory, obscene, pornographic, paedophilic, libellous, invasive of another's privacy, hateful, or racially, ethnically objectionable, disparaging, relating or encouraging money laundering or gambling, or otherwise unlawful in any manner whatever;
 - (c) harm minors in any way;
 - (d) infringes any patent, trademark, copyright or other proprietary rights;
 - (e) violates any law for the time being in force;
 - (f) deceives or misleads the addressee about the origin of such messages or communicates any information which is grossly offensive or menacing in nature;
 - (g) impersonate another person;
 - (h) contains software viruses or any other computer code, files or programs designed to interrupt, destroy or limit the functionality of any computer resource;
- (xv) threatens the unity, integrity, defence, security or sovereignty of India, friendly relations with foreign states, or public order or causes incitement to the commission of any cognizable offence or prevents investigation of any offence or is insulting any other nation.
- (xvi) Achieving or trying to achieve illegal access to features on GeM Website not specifically authorised or exceeding the scope of authorized access to or other features of the GeM Website;

- (xvii) Obstructing or causing GeM to lose (in whole or in part) the services provided by any internet service provider ("ISPs") or carrying out any cyber security incident;
- (xviii) Sending unsolicited emails, bulk messaging, auto messaging, junk email, spam and like.

24. Incident management Policy on GeM: GeM is a trust based system and self-declaration is the key, along with a strong automated process to penalize any deviant behaviour on part of Sellers / Buyers. For this purpose, deviations from the terms and conditions of procurement on GeM, including general terms and conditions, special and additional terms and conditions and any other relevant Government rules and guidelines, are termed as "deviation". A deviation can occur while listing the products on GeM, at pre-contract stage, during bidding or at post contract stage on GeM. The mechanism for reporting and initiating action on such deviation has been detailed in the Incident Management Policy available on GeM portal under Resources. All stake holders of GeM shall be bound by the actions as detailed in the Incident Management Policy.

All administrative actions under this Incident management Policy, taken by GeM against any of the stakeholders shall not cause any limitation on the legal and/or contractual remedies including any financial recoveries, available to Buyers/Sellers under the Terms and Conditions of contract and/or GeM policies. In case the Buyer / Seller choose to pursue any of these remedies, GeM shall not be made party to such proceedings / remedial actions taken by Buyer/Seller under the contractual provisions.

25. Use of Aadhaar Number in GeM: Purpose of the Aadhaar authentication in GeM is to identify the user using eKYC. GeM has provisioned the option for Sellers and Buyers to provide virtual Aadhaar ID instead Aadhaar number. GeM receives First Name, Last Name, Mobile Number, Email ID, DOB and Gender details. It is used to link the mobile number with the user who is registering on GeM; on which subsequently OTP is sent for achieving the property of non-repudiation in different artefacts / documents generated on GeM. GeM has provisioned an alternative Identity Information option through PAN based verification to Sellers.

26. Compliance of Restrictions under Rule 144 (xi) of GFR 2017: Restrictions on procurement from a bidder of a country which shares a land border with India

- I. Any bidder from a country which shares a land border with India will be eligible to bid in this tender only if the bidder is registered with the Competent Authority.
- II. "Bidder" (Seller / Service Provider) means any person or firm or company, including any member of a consortium or joint venture (that is an association of several persons, or firms or companies), every artificial juridical person not falling in any of the descriptions of bidders stated hereinbefore, including any agency branch or office controlled by such person, participating in a procurement process.
- III. "Bidder from a country which shares a land border with India" for the purpose of this Order means: -

- a. An entity incorporated, established, or registered in such a country; or
- b. A subsidiary of an entity incorporated, established, or registered in such a country; or
- c. An entity substantially controlled through entities incorporated, established, or registered in such a country; or
- d. An entity whose beneficial owner is situated in such a country; or
- e. An Indian (or other) agent of such an entity; or
- f. A natural person who is a citizen of such a country; or
- g. A consortium or joint venture where any member of the consortium or joint venture falls under any of the above

IV. The beneficial owner for the purpose of (iii) above will be as under:

1. In case of a company or Limited Liability Partnership, the beneficial owner is the natural person(s), who, whether acting alone or together, or through one or more juridical person, has a controlling ownership interest or who exercises control through other means. Explanation—
 - a. "Controlling ownership interest" means ownership of or entitlement to more than twenty-five per cent. of shares or capital or profits of the company;
 - b. "Control" shall include the right to appoint majority of the directors or to control the management or policy decisions including by virtue of their shareholding or management rights or shareholders agreements or voting agreements;
2. In case of a partnership firm, the beneficial owner is the natural person(s) who, whether acting alone or together, or through one or more juridical person, has ownership of entitlement to more than fifteen percent of capital or profits of the partnership;
3. In case of an unincorporated association or body of individuals, the beneficial owner is the natural person(s), who, whether acting alone or together, or through one or more juridical person, has ownership of

or

entitlement to more than fifteen percent of the property or capital or profits of such association or body of individuals;
4. Where no natural person is identified under (1) or (2) or (3) above, the beneficial owner is the relevant natural person who holds the position of senior managing official;
5. In case of a trust, the identification of beneficial owner(s) shall include identification of the author of the trust, the trustee, the beneficiaries with fifteen percent or more interest in the trust and any other natural person exercising ultimate effective control over the trust through a chain of control

or ownership.

- V. An Agent is a person employed to do any act for another, or to represent another in dealings with third person.
- VI. The successful bidder shall not be allowed to sub-contract works to any contractor from a country which shares a land border with India unless such contractor is registered with the Competent Authority.

Any false declaration and non-compliance of the above would be a ground for immediate termination of the contract and further legal action in accordance with the laws.

Clause 27: Caution Money Deposit:

(i) All sellers on GeM are required to deposit a one-time amount as under as caution money:

- a) Seller Turnover less than 1 Crore: Rs 5,000/-
- b) Seller Turn over > 1 Crore but < 10 Crore: Rs 10,000/-
- c) Seller Turn over > 10 Crore: Rs 25,000/-

(ii) The above caution money shall remain at the disposal of GeM SPV. This can be forfeited in part or in full (as per approval of CEO (GeM)) in following circumstances:

- a) Seller rejects or does not accept any Direct Purchase / L-1 Purchase order within defined timelines leading to order auto cancellation.
- b) Failure of the seller in executing any GeM contract or if the Seller fails or neglects to observe or perform any of his obligations under the contract (applicable only in respect of contracts that did not have provision of Performance Security / PBG).
- c) Withdraws any bid submitted on GeM within the period of validity of the bid.
- d) Fails to furnish requisite performance security / PBG as per GeM e-bid / RA conditions.

(iii) In case the Caution Money of any seller is forfeited in full or part and his caution money deposit goes below the threshold indicated in para 1 above, the seller account shall be put on hold till the seller re-coups the caution Money account to required value. Seller's stock will become zero for all categories and seller will not be allowed to update anything till the caution money is topped up to minimum required amount.

(iv) Forfeiture of caution money as per above shall be over and above any other actions taken against such sellers as per GeM Incident Management Policy and shall be without any prejudice to the rights and remedies available to GeM and / or Buyer as per provisions of the relevant contracts.

Clause 28: CMS 3.0 and OEM - Reseller responsibility matrix:

GeM has implemented enhanced Catalogue Management System (CMS 3.0) on GeM Portal. The Primary Objective of CMS 3.0 is to offer higher level of ownership & accountability to OEMs & its approved Resellers while maintaining Efficiency, Transparency & Inclusiveness of GeM. Complete and detailed Obligations and Privileges matrix of the different stakeholders in different quadrants is given in CMS document available on GeM Portal and OEMs and Resellers are bound to operate on GeM in compliance with the CMS document as updated from time to time.

1) CMS Quadrant 1 (CMS Q1): Product offers in categories under Q1 will be solely offered by GeM validated OEMs. OEM shall be exclusively responsible for maintaining currency and sanity of catalogue and its offer in the Market Place. OEM shall be absolutely and exclusively responsible and be legally liable for sanity and quality of offers including Warranty and After Sales Service obligations.

2) CMS Quadrant 2 (CMS Q2): OEMs as well as pre-Authorized Resellers can offer products in Q2. OEMs shall operate Market Place subject to providing its complete list of Open market authorized sellers along with formal commitment to list and maintain all appropriate and current Product Catalogue for pairing by its Resellers. OEM shall be absolutely and exclusively responsible and be legally liable for sanity and quality of catalogues including Warranty and After Sales Service obligations. Authorize Resellers shall be responsible for Pairing their offer with the already existing Product Catalogue created by the OEM. However, resellers can Update their Offer Price, Stock and Delivery Locations solely at their own discretion and shall be solely responsible for the same.

3) CMS Quadrant 3 (CMS Q3): Catalogue creation in categories under Q3 can be from OEMs and/or their Authorized Resellers concurrently. In case OEM has not created Product Catalogue, Authorized Resellers of OEMs are also permitted to do the same. However, OEM (when registered on GeM and taken OEM Dashboard) shall be responsible for Validating & verifying the Catalogue uploaded by Reseller, Maintaining the Catalogue by adding/updating the Specifications, MRP etc. specific to catalogue. OEM shall also assume all responsibility and legal liability for sanity and quality of offers including Warranty and After Sales Service obligations. However, resellers can Update their Offer Price, Stock and Delivery Locations solely at their own discretion and shall be solely responsible for the same.

4) CMS Quadrant 4 (CMS Q4): Catalogue creation in categories under Q4 can be done by OEMs as well as by any Reseller also. However, OEM (when registered on GeM and taken OEM Dashboard) shall be responsible for Validating & verifying the Catalogue uploaded by Reseller, Maintaining the Catalogue by adding/updating the Specifications, MRP etc. specific to catalogue. However, there is no requirement of any endorsement or authorization of the reseller by the OEM. Resellers can Update their Offer Price, Stock and Delivery Locations solely at their own discretion and shall be solely responsible for the same. Reseller will also be responsible for providing Replacement Warranty in case of Q4 products and Buyer shall not be required to take up with OEM for any warranty claims.

5) CMS (Special Category) : The Special Category is a specialized segment outside the four quadrants for select few categories that require a customized behavior such as Self-Help Groups (SHG) categories.

In Q3 and Q4, in case of re-sellers, if the reseller has not been approved as an authorized re-seller by the OEM on GeM, the re-seller is required to give an undertaking as under while uploading the product, while accepting any order and while participating in any bid:

“I hereby undertake that I have made arrangements for getting the stores from authorized distributor / dealer / channel partner of the OEM of the offered product. At the time of delivery of goods, I will provide necessary chain documents to prove that the supplied goods are genuine and are being sourced from authorized distributor / dealer / channel partner of the OEM. In case of any complaint from the Buyer / Consignee about genuineness of the supplied products, I shall be responsible for providing genuine replacement supplies.”

By uploading any product on GeM or accepting any order on GeM or by participating in any bid on GeM, the re-seller is deemed to have given above undertaking and is liable for compliance of the same.

Further in view of the on-line verification of Seller credentials by the OEM on GeM platform, there is no need for Buyer to ask for or insist on furnishing of OEM authorization in bids in respect of “OEM verified Catalogue” offered by "OEM Verified Reseller". OEM authorization is also not required to be sought and checked by Buyers in case of bids for products in Q1 or Q2.

Clause 29: One Bid per Bidder

A Bidder shall submit only one bid in a particular bidding process (unless otherwise allowed in the bid STC / ATC conditions). In case of a holding company having more than one independent manufacturing units or more than one unit having common business ownership / management, only one unit should quote. Similar restrictions shall apply to closely related sister companies. Bidder's sister/ Associated/ Allied concern(s) participating or applying against the same tender, shall lead to disqualification of Bidders. Sister/ Associated/ Allied concern means a company, society, partnership firm or proprietorship firm having one or more common persons as Director/ Partner/ Member/ Owner. A Bidder who submits more than one bid will cause all the proposals submitted in the particular bid to be disqualified. In relation to the above, a person will include firm(s) of Proprietorship / Partnership Firm / Limited Liability Partnership / Private Limited / Limited company / Society registered under Society's Act / Statutory Bodies / any other legal entity, as the case maybe, & will be deemed to have submitted multiple bids in a particular bid if a person bids in any of the two formats given below:

- a) individual or proprietorship format and/or
- b) a partnership or association of persons format and/or
- c) a company format

Whereby,

- A company shall for this purpose include any artificial person whether constituted under the Indian laws or of any other country.
- A person shall be deemed to have bid in a partnership format or in association of persons format if he is a partner of the firm which has submitted the bid or is a member of any association of persons which has submitted a bid.
- A person shall be deemed to have bid in a company format if the person holds:
 - a) more than 10% (ten percent) of the voting share capital of the company which has submitted a bid, or
 - b) is a director and / or Key Managerial Personnel of the company which has submitted a bid, or
 - c) holds more than 10% (ten percent) of voting share capital in and/or is a director and / or Key Managerial Personnel of a holding company of that company which has submitted the bid.

By making a bid pursuant to the Tender Documents, the bidder / tenderer shall be deemed to have declared that the bidder / tenderer has not made any other bid or multiple bids as understood or deemed in terms of this clause.

All the bids of a bidder who has submitted multiple bids, as per the clause, shall be rejected and Earnest Money Deposit for all such bids shall be forfeited, not by way of penalty or liquidated damages but by way of reimbursement of the pre-estimated costs likely to be incurred by the buyer towards bidding process and in the scrutiny & evaluation of bids.

In addition to the above, bidders found to be in contravention to the said clause will be liable for administrative actions.

***** END OF DOCUMENT *****

ANNEXURE-A
BID SPECIFIC ADDITIONAL TERMS & CONDITIONS FOR THE
PROCUREMENT OF B7, B16 & COMMERCIAL GRADE FASTENERS

SI No	BHEL requirement	Agree / Disagree
1	<p>SCOPE OF SUPPLY-</p> <p>i) Manufacture & Supply of B7, B16 & Commercial grade Fasteners as per Indian Standards, BHEL drawings, BPS & TDC as applicable.</p> <p>ii) To be despatched to Ward 55, BHEL Trichy Stores</p> <p>iii) List of items shall be as per Unpriced bid enclosed (Annexure-B).</p>	
2	<p>TECHNICAL REQUIREMENT-</p> <ol style="list-style-type: none"> 1. Bidders shall comply with all the technical requirements mentioned in respective Indian standards, drawings, TDC & BPS in Unpriced bid (Annexure-B). 2. Submit duly filled in Unpriced bid enclosed (Annexure-B). 3. Submit duly filled in Checklist enclosed along with supporting documents (Annexure-F). 4. Submit duly signed BPS, TDC:5:164 & drawings for Compliance to BOQ Specifications. 5. Quantity mentioned against each item may vary up to +/- 25% of the enquiry quantity. Bidders are bound to accept the orders accordingly. 6. Bids qualifying the PQR criteria (Annexure-C) shall be evaluated for techno-commercial soundness. Only bids of techno-commercially qualified bidders shall be considered for price evaluation. <p>Deviation if any shall be clearly indicated in a separate sheet. UNDISCLOSED DEVIATIONS ARE NOT ACCEPTABLE.</p>	
3	<p>VALIDITY OF OFFER-</p> <p>The quotation shall be valid at least for a period of 90 days from the date of technical bid opening / 60 days from the date of price evaluation whichever is later. Offer with lesser validity may not be considered.</p>	
4	<p>DELIVERY PERIOD-</p> <p>90 days from the date of PO</p> <p>Delivery is the essence of the contract. Supplies are to be completed within 45 days from LOI/PO date. As delivery will affect our project requirements, kindly quote for the above delivery period only. Bidder has to strictly confirm to the delivery terms.</p>	
5	<p>LIQUIDATED DAMAGES-</p> <p>If the bidder fails to deliver the item within the period specified in the contract the purchaser shall deduct Liquidated Damages, a sum equivalent to 0.5% of the price for each week of delay up to a maximum of 10% of the price of delayed/undelivered portion.</p> <p>LD will be reckoned from the date of Invoice date / Lorry Way bill date / E-Way Bill date whichever is later. Applicability of LD shall be on undelivered portion of the PO.</p>	
6	<p>DELIVERY TERM-</p> <p>FOR Ward 55, BHEL Trichy Stores basis</p> <p>Dispatch of items shall be made to Ward 55, BHEL Trichy Stores, Tamil Nadu state, India based on Delivery instructions by BHEL-PC.</p>	
7	<p>EVALUATION & ORDERING-</p> <ol style="list-style-type: none"> 1. Only Techno-commercially qualified bidders shall be considered for price evaluation. Price evaluation shall be through Reverse auction in GeM portal with H1-Highest Priced Bid Elimination. 2. Evaluation of bids and ranking of bidders shall be done on package basis. Bidder shall quote for all items of a package mandatorily. 3. Quoted rates shall be inclusive of GST. 4. Minimum Order Quantity (MOQ) / Minimum Order Value (MOV) condition will not be accepted. Bids of such suppliers (if any) insisting for MOQ / MOV will be rejected. <p>THIS IS A FIXED PRICE CONTRACT AND PRICES ARE FIRM TROUGHOUT THE EXECUTION OF THE CONTRACT.</p>	
8	<p>PREFERENCE TO MAKE IN INDIA PRODUCTS (FOR BIDS < 200 CRORE)-</p> <p>Preference shall be given to Class 1 local supplier as defined in public procurement (Preference to Make in India), Order 2017 as amended from time to time and its subsequent Orders/Notifications issued by concerned Nodal Ministry for</p>	

ANNEXURE-A

**BID SPECIFIC ADDITIONAL TERMS & CONDITIONS FOR THE
PROCUREMENT OF B7, B16 & COMMERCIAL GRADE FASTENERS**

	<p>specific Goods/Products. The minimum local content to qualify as a Class 1 local supplier is denote in the bid document. If the bidder (manufacturer) wants to avail the Purchase preference, the bidder must upload a certificate (as per Annexure-D) regarding the percentage of the local content and the details of locations at which the local value addition is made along with their bid, failing which no purchase preference shall be granted. In case the bid value is more than Rs 10 Crore, the declaration relating to percentage of local content shall be certified by the statutory auditor or cost auditor, if the OEM is a company and by a practicing cost accountant or a chartered accountant for OEMs other than companies as per the Public Procurement (preference to Make-in -India) order 2017 dated 04.06.2020.</p> <p>Only Class-I and Class-II Local suppliers as per MII order dated 4.6.2020 will be eligible to bid. Non - Local suppliers as per MII order dated 04.06.2020 are not eligible to participate. However, eligible micro and small enterprises will be allowed to participate. In case Buyer has selected Purchase preference to Micro and Small Enterprises clause in the bid, the same will get precedence over this clause.</p>	
9	<p>PURCHASE PREFERENCE TO MICRO AND SMALL ENTERPRISES (MSES)- Purchase preference will be given to MSEs as defined in Public Procurement Policy for Micro and Small Enterprises (MSEs) Order, 2012 dated 23.03.2012 issued by Ministry of Micro, Small and Medium Enterprises and its subsequent Orders / Notifications issued by concerned Ministry. If the bidder wants to avail the Purchase preference, the bidder must be the manufacturer of the offered product in case of bid for supply of goods. Traders are excluded from the purview of Public Procurement Policy for Micro and Small Enterprises. Udyam Registration certification shall be submitted.</p> <p>If L-1 is not an MSE and MSE Seller (s) has/have quoted price within L-1+ 15% (Selected by Buyer) of margin of purchase preference / price band defined in relevant policy, such Seller shall be given opportunity to match L-1 price and contract will be awarded for 25% (selected by Buyer) percentage of total QUANTITY.</p>	
10	<p>GUARANTEE- The materials are to be guaranteed for satisfactory performance for a period of 24 months from the date of dispatch or 18 months from the date of commissioning / putting into use whichever is earlier. Pipe suppliers shall guarantee for the coating on the pipes also.</p> <p>Any defect noticed during the above period, the same shall be rectified / replaced free of cost on FOR destination basis within a reasonable time, maximum limited to the agreed delivery period, to the satisfaction of BHEL and the End User.</p> <p>To this effect a guarantee certificate should be sent along with the dispatch documents in the event of an order. No deviation in this regard shall be accepted.</p>	
11	<p>INSPECTION- Inspection requirements and documents / certification shall be as per BHEL drawings, BPS & TDC as applicable. Inspection will be done by BHEL / Authorized agency (TUV SUD / Bureau Veritas India Pvt Ltd). Inspection charges of BHEL / Their representative are to BHEL A/c. Any other testing charges should be included in the quoted prices.</p> <ul style="list-style-type: none">➤ All facilities, equipment and instruments required for inspection shall be provided by the contractor free of cost. BHEL's Representatives will have free access to contractor's works during the currency of the contract.➤ BHEL shall have general supervision and direction over the work. BHEL has the authority to stop the work, whenever such stoppage may be necessary to ensure the proper execution of the contract. BHEL shall also have the authority to reject all the work which does not conform to the specification. <p>BHEL if required may test the finished sample per lot/size at NABL approved Lab at the bidder's cost.</p>	
12	<p>QUALITY DOCUMENTS One original + two copies of Quality Documents, as called for in the Inspection test plan/Purchase order shall be sent to Purchase / Piping centre BHEL Chennai immediately after the shipment / despatch of Items. All the quality documents are to be submitted in soft copy (in CD format) apart from the hard copy.</p>	

ANNEXURE-A

**BID SPECIFIC ADDITIONAL TERMS & CONDITIONS FOR THE
PROCUREMENT OF B7, B16 & COMMERCIAL GRADE FASTENERS**

13	<p>TERMS OF PAYMENT: Payment terms shall be as per Clause “Payment Timelines” of the GeM bid, i.e., 100% payment within 90 days of issue of CRAC.</p> <p>However, preference in payment shall be given as following:</p> <ol style="list-style-type: none">a. 100% payment within 60 days of issue of CRAC for Medium category bidders subject to submission of relevant documents.b. 100% payment within 45 days of issue of CRAC for MSE (Micro and small) bidders subject to submission of relevant documents. <p><u>No other payment terms will be accepted. If bidders propose for any other payment term other than indicated above, such bids will be rejected.</u></p> <p><u>PAYMENT DOCUMENTS -</u></p> <p>Payment shall be made against presentation of following documents to Finance Department by Purchase department:</p> <ol style="list-style-type: none">a) Tax Invoice in triplicateb) Delivery Challan in triplicate whichever is applicablec) Guarantee certificated) Lorry Way Bill & E-way bill (Original + Two copies)e) CRAC (Consignee Receipt & Acceptance Certificate) in GeMf) Quality documents (as per approved QP/PO) <p>Hence,</p> <ol style="list-style-type: none">1. Soft copy of Invoice and LR should be sent immediately after dispatch by e-mail to Purchase.2. Hard copy should be sent subsequently within 1 week. <p>Payment shall be processed only after receipt of CRAC in GeM.</p>	
14	<p><u>CANCELLATION / TERMINATION OF CONTRACT, DEFAULT / BREACH OF CONTRACT AND RISK PURCHASE:</u></p> <p>In case of abnormal delays (beyond the maximum late delivery period as per Penalty clause) in supplies / defective supplies or non-fulfilment of any other terms and conditions given in Purchase Order as enumerated subsequently in this clause, Purchaser shall be entitled to cancel the Order / Contract either in whole or portion thereof without compensation to Seller / Contractor and if the Purchaser so desires, may procure upon such terms and in such manner as deemed appropriate, stores not so delivered or others of similar description where stores exactly complying with particulars are not, in the opinion of the Purchaser, which shall be final, readily procurable, at the risk and cost of the Seller / Contractor and the Seller / Contractor shall be liable to the Purchaser for any excess costs provided that the Seller / Contractor shall continue the performance of the Order / Contract to the extent not cancelled under the provisions of this clause. The Seller / Contractor shall on no account be entitled to any gain on such repurchases. If bidder does not agree to the above Risk Purchase Clause, BHEL reserves the right to reject the offer.</p> <p>Risk & Cost Clause, in line with Conditions of Contract may be invoked in any of the following cases:</p> <ol style="list-style-type: none">i. Contractor / supplier’s poor progress of the work vis-à-vis execution timeline as stipulated in the Contract, backlog attributable to contractor/ supplier including unexecuted portion of work / supply does not appear to be executable within balance available period (#) considering its performance of execution.ii. Withdrawal from or abandonment of the work by contractor before completion of the work as per contract.iii. Non completion of work / Non-supply by the Contractor / supplier within scheduled completion / delivery period as per Contract or as extended from time to time, for the reasons attributable to the contractor / supplier.iv. Termination of Contract on account of any other reason (s) attributable to Contractor / Supplier.v. Assignment, transfer, subletting of Contract without BHEL’s written permission resulting in termination of Contract or part thereof by BHEL.vi. Non-compliance to any contractual condition or any other default attributable to Contractor / Supplier. <p>Risk and Cost amount against Balance Work: Risk & Cost Amount= [(A-B) + (A x H/100)] Where, A= Value of Balance scope of Work / Supply (*) as per rates of new contract B= Value of Balance scope of Work / Supply (*) as per rates of old contract being paid to the contractor / supplier at the time of termination of contract i.e. inclusive of PVC & ORC, if any.</p>	

ANNEXURE-A

**BID SPECIFIC ADDITIONAL TERMS & CONDITIONS FOR THE
PROCUREMENT OF B7, B16 & COMMERCIAL GRADE FASTENERS**

	<p>H= Overhead Factor to be taken as 5</p> <p>In case (A-B) is less than 0 (zero), value of (A-B) shall be taken as 0 (zero).</p> <p>*(Balance scope of work / supply)</p> <p>Difference of Contract Quantities and Executed Quantities as on the date of issue of Letter for 'Termination of Contract', shall be taken as balance scope of Work / Supply for calculating risk & cost amount.</p> <p>Contract quantities are the quantities as per original contract. If, Contract has been amended, quantities as per amended Contract shall be considered as Contract Quantities.</p> <p>Items for which total quantities to be executed have exceeded the Contract Quantities based on drawings issued to contractor from time to time till issue of Termination letter, then for these items total Quantities as per issued drawings would be deemed to be contract quantities.</p> <p>Substitute / extra items whose rates have already been approved would form part of contract quantities for this purpose. Substitute / extra items which have been executed but rates have not been approved, would also form part of contract quantities for this purpose and rates of such items shall be determined in line with contractual provisions.</p> <p>However, increase in quantities on account of additional scope in new tender shall not be considered for this purpose. Note: In case portion of work is being withdrawn, contract quantities pertaining to portion of work withdrawn shall be considered as 'Balance scope of work / supply' for calculating Risk & Cost amount.</p> <p><u>LD against delay in executed work / supply in case of Termination of Contract in case of Risk and Cost Option</u></p> <p>LD against delay in executed work / supply shall be calculated in line with LD clause of the contract for the delay attributable to contractor / supplier. For limiting maximum LD value, contract value shall be taken as Executed Value of work / supply.</p> <p>Method for calculation of "LD against delay in executed work / supply" is given below.</p> <p>i. Let the time period from scheduled date of start of work till termination of contract excluding the period of Hold (if any) not attributable to contractor / supplier= T1</p> <p>ii. Let the value of executed work / supply till the time of termination of contract= X</p> <p>iii. Let the Total Executable Value of work / supply for which inputs / fronts were made available to contractor / supplier and were planned for execution till termination of contract= Y</p> <p>iv. Delay in executed work / supply attributable to contractor/supplier i.e. T2= (1- X/Y) * T1</p> <p>v. LD shall be calculated in line with LD clause of the Contract for the delay attributable to contractor / supplier taking "X" as Contract Value and "T2" as delay attributable to contractor / supplier.</p> <p>Note: In case portion of work / supply is withdrawn, no LD shall be applicable for portion of work / supply withdrawn.</p> <p>Recovery from Supplier</p> <p>Recoveries from contractor / supplier on whom risk & cost has been invoked shall be made from the following:</p> <p>i. Dues available in the form of Bills payable to contractor / supplier, SD, BG's against the same contract.</p> <p>ii. Dues payable to contractor / supplier against other contracts in the same Region / Unit / Division of BHEL.</p> <p>iii. Dues payable to contractor / supplier against other contracts in the different Region / Unit / division of BHEL.</p> <p>Legal Options for recovery of dues payable by the supplier / contractor.</p> <p>Bids deviating from the above BHEL's standard condition will be rejected.</p>	
15	<p><u>NON-DISCLOSURE AGREEMENT (NDA):</u></p> <p>The bidders shall enter into the Non-disclosure agreement totally voluntarily, with full knowledge of its meaning and without duress. (Format attached – as per Annexure-E).</p>	

ANNEXURE-A

**BID SPECIFIC ADDITIONAL TERMS & CONDITIONS FOR THE
PROCUREMENT OF B7, B16 & COMMERCIAL GRADE FASTENERS**

16	<p><u>FRAUD PREVENTION POLICY:</u></p> <p>The Bidder along with its associate/ collaborators/ sub-contractors/ sub-Bidders/ consultants/ service providers shall strictly adhere to BHEL Fraud Prevention Policy displayed on BHEL website http://www.bhel.com and shall immediately bring to the notice of BHEL Management about any fraud or suspected fraud as soon as it comes to their notice.</p>	
17	<p><u>SUSPENSION OF BUSINESS DEALINGS WITH SUPPLIERS / CONTRACTORS:</u></p> <p>The offers of the bidders who are under suspension as also the offers of the bidders, who engage the services of the banned firms /principal/agents, shall be rejected. The list of banned firms is available on BHEL web site www.bhel.com.</p> <p>Integrity commitment, performance of the contract and punitive action thereof:</p> <p>Commitment by BHEL</p> <p>BHEL commits to take all measures necessary to prevent corruption in connection with the tender process and execution of the contract. BHEL will during the tender process treat all Bidder(s) in a transparent and fair manner, and with equity.</p> <p>Commitment by Bidder/ Supplier/ Contractor</p> <ul style="list-style-type: none">• The bidder/ supplier/ contractor commit to take all measures to prevent corruption and will not directly or indirectly influence any decision or benefit which he is not legally entitled to nor will act or omit in any manner which tantamount to an offence punishable under any provision of the Indian Penal Code, 1860 or any other law in force in India.• The bidder/ supplier/ contractor will, when presenting his bid, disclose any and all payments he has made, and is committed to or intends to make to agents, brokers or any other intermediaries in connection with the award of the contract and shall adhere to relevant guidelines issued from time to time by Govt. of India/ BHEL.• The bidder/ supplier/ contractor will perform/ execute the contract as per the contract terms & conditions and will not default without any reasonable cause, which causes loss of business/ money/ reputation, to BHEL. <p>If any bidder/ supplier/ contractor during pre-tendering/ tendering/ post tendering/ award/ execution/ post execution stage indulges in any act, including but not limited to, mal-practices, cheating, bribery, fraud or and other misconduct or formation of cartel so as to influence the bidding process or influence the price or tampers the tendering process or acts or omits in any manner which tantamount to an offence punishable under any provision of the Indian Penal Code, 1860 or any other law in force in India, then, action may be taken against such bidder/ supplier/ contractor as per extant guidelines of the company available on www. bhel.com and/or under applicable legal provisions. Guidelines for suspension of business dealings is available in the webpage: http://www.bhel.com/vender_registration/vender.php.</p>	
18	<p><u>PROHIBITED ACTS UNDER COMPETITION ACT, 2002:</u></p> <p>All the bidders should desist from doing any acts prohibited under Chapter-II of the Competition Act, 2002. If any such instance is observed during this tender will attract disciplinary action as per BHEL policies.</p>	
19	<p><u>IN THE EVENT OF FORCE MAJEURE:</u></p> <ol style="list-style-type: none">a. Notwithstanding the provisions contained in other clauses, the supplier shall not be liable for imposition of any such sanction so long the delay and/or failure of the supplier in fulfilling its obligations under the contract is the result of an event of Force Majeure. For purposes of this clause, Force Majeure means an event beyond the control of the supplier and not involving the supplier's fault or negligence and which is not foreseeable and not brought about at the instance of the party claiming to be affected by such event and which has caused the non – performance or delay in performance. Such events may include, but are not restricted to, wars or revolutions, hostility, acts of public enemy, civil commotion, sabotage, fires, floods, explosions, epidemics, quarantine restrictions, strikes excluding by its employees, lockouts excluding by its management, freight embargoes and Acts of GOD.b. If a Force Majeure situation arises, the supplier shall promptly notify the Purchaser/Consignee in writing of such conditions and the cause thereof within twenty-one days of occurrence of such event. Unless otherwise directed by the Purchaser/Consignee in writing, the supplier shall continue to perform its obligations under the contract as far as reasonably practical, and shall seek all reasonable alternative means for performance not prevented by the Force Majeure event.c. If the performance in whole or in part or any obligation under this contract is prevented or delayed by any reason of Force Majeure for a period exceeding sixty days, either party may at its option terminate the contract without any financial repercussion on either side.	



ANNEXURE-A

**BID SPECIFIC ADDITIONAL TERMS & CONDITIONS FOR THE
PROCUREMENT OF B7, B16 & COMMERCIAL GRADE FASTENERS**

	In case due to a Force Majeure event the Purchaser/Consignee is unable to fulfil its contractual commitment and responsibility, the Purchaser/Consignee will notify the supplier accordingly and subsequent actions taken on similar lines described in above sub-paragraphs.	
20	<u>LAWS GOVERNING THE CONTRACT:</u> a. The contract shall be governed by the Laws of the Government of India in force. b. Irrespective of the place of execution of the contract, place of delivery, place of payment under the contract, the contract shall be deemed to have been made at the place at which the Acceptance of the tender has been issued.	
21	<u>JURISDICTION OF THE COURT</u> The Courts of the place from where the acceptance of the tender has been issued shall alone have jurisdiction to decide any dispute arising out of or in respect of the contract.	
22	<u>RESOLUTION OF DISPUTES:</u> The Parties agree that if at any time (whether before, during or after the arbitral or judicial proceedings), any Disputes (which term shall mean and include any dispute, difference, question or disagreement arising in connection with construction, meaning, operation, effect, interpretation or breach of the contract/tender which the Parties are unable to settle mutually), arise inter-se the Parties, the same may, be referred by either party to Conciliation to be conducted through Independent Experts Committee to be appointed by competent authority of BHEL from the BHEL Panel of Conciliators. The proceedings of Conciliation shall broadly be governed by Part-III of the Arbitration and Conciliation Act 1996 or any statutory modification thereof. Notes: 1. No serving or a retired employee of BHEL/Administrative Ministry of BHEL shall be included in the BHEL Panel of Conciliators. 2. Any other person(s) can be appointed as Conciliator(s) who is/are mutually agreeable to both the parties from outside the BHEL Panel of Conciliators. The proceedings of Conciliation shall broadly be governed by Part-III of the Arbitration and Conciliation Act 1996 or any statutory modification thereof. Except as provided elsewhere in this Contract, in case amicable settlement is not reached between the parties, in respect of any dispute or difference; arising out of the formation, breach, termination, validity or execution of the Contract; or, the respective rights and liabilities of the Parties; or, in relation to interpretation of any provision of the Contract ; or , in any manner touching upon the Contract, then, either Party may , by a notice in writing to other Party refer such dispute or difference to sole arbitration of an arbitrator appointed as per the Arbitration and Conciliation Act, 1996 (India) or statutory modification or re-enactment thereof and the rules made thereunder and for the time being in force. The Arbitrator shall pass a reasoned award and the award of the Arbitrator shall be final and binding upon the parties. Subject as aforesaid, the provision of Arbitration & Conciliation Act 1996 (India) or statutory modification or re-enactment thereof and the rules made thereunder and for the time being in force shall apply to the arbitration proceeding under this clause. The seat of arbitration shall be Chennai, Tamil Nadu, India. The cost of arbitration shall be borne as per the award of the Arbitrator. Subject to arbitration in terms of clause above, the Courts at Chennai, Tamil Nadu, India shall have exclusive jurisdiction over any matter arising out of or in connection with this Contract. Notwithstanding the existence or any dispute or difference and/or reference for the arbitration, the vendor shall proceed with and continue without hindrance the performance of its obligation under this Contract with due diligence and expedition in a professional manner except where the Contract has been terminated by either Party in terms of this Contract. <u>In Case of Contract with Public Sector Enterprise (PSE) or a Government Department, the following shall be applicable:</u> In the event of any dispute or difference relating to the interpretation and application of the provisions of commercial contract(s) between Central Public Sector Enterprises (CPSEs)/Port Trusts inter se and also between CPSEs and Government Departments/Organizations (Excluding disputes concerning Railways, Income Tax, Customs & Excise Departments, such dispute or difference shall be taken up by either party for resolution through AMRCD as mentioned in DPE OM No. 4(1)/2013 –DPE (GM)/FTS-1835 dated 22-05-2018.	

ANNEXURE-A

**BID SPECIFIC ADDITIONAL TERMS & CONDITIONS FOR THE
PROCUREMENT OF B7, B16 & COMMERCIAL GRADE FASTENERS**

23	<p><u>SET-OFF CLAUSE:</u></p> <p>BHEL, Piping Centre, Chennai shall have the right to recover any money which in the sole opinion of BHEL is due from the Contractor from any money due to the Contractor like Payment of bills, payment of any amounts due, release of Security Deposit or return of Bank Guarantees furnished</p> <ul style="list-style-type: none">a. Under this tender/contract (OR)b. Any other contract placed on the contractor by BHEL, Piping centre, Chennai (OR)c. Any other contract placed on the contractor by any Unit/s of BHEL <p>BHEL, Piping Centre, Chennai also reserves the right to set off the amount of the contractor available in any form, against any claims of any other contract with BHEL.</p>	
24	<p><u>CAUTION:</u></p> <p>a) The suppliers are severely cautioned to note that the price bid document accepts the price in figures only. It does not allow the supplier to write the value by words. Therefore, all care shall be exercised by the supplier while filling in the figures. Once the price bid is opened no option is available for the supplier to retract the offer under any grounds. If a supplier, for any reason whatsoever approaches BHEL with a request for change in the price, it would be treated as going back on the offer submitted. In such cases, action would be initiated by BHEL for suspending further business dealings with such suppliers as per policy of BHEL which prevails at that point of time.</p> <p>b) The language in the tender documents downloaded by the Bidders shall at no point of time be changed, altered or modified in any manner by the Tenderer. If such changes are made by any tenderer, it shall be considered as tampering with BHEL's terms and the offer shall be summarily rejected, whenever it is noticed by BHEL. Such Bidders would be disqualified from the Bidding Process and their offers would be forfeited / Bank Guarantees invoked. They would also not be allowed to participate in future tenders of BHEL.</p>	
25	<p><u>GENERAL:</u></p> <ul style="list-style-type: none">i. The PO copy with all details will be given to successful bidders in soft mode only.ii. Acknowledgement for receipt of PO shall be sent within one week from the date of receipt.iii. BHEL reserves the right to cancel this tender without assigning any reasons what so ever.iv. Deviation taken after placement of order will not be accepted (Both technical as well as on delivery).v. Suppliers to analyze in detail, at the time of submission of offer with reference to our "delivery" requirement of item and confirm compliance.vi. BHEL reserves the right to negotiate or re-float the tender opened, if L1 price / other details are not acceptable to them.vii. Any other terms or conditions mentioned in your offer other than the above mentioned formats will not be evaluated and will be considered null & void. Hence your offer shall contain ONLY the above mentioned formats.viii. Bids not accepting to above conditions will be liable for rejection.ix. For verification of data submitted towards evaluation of bidder's capability, BHEL may decide to visit the bidder(s) works. Any fact found deviating from submitted data shall make the bidder liable to be disqualified.	
26	<p><u>ENCLOSURES:</u></p> <div style="display: flex; justify-content: space-around; align-items: center;"><div style="text-align: center;"> Drawings & Technical Specificati</div><div style="text-align: center;"> Annexures to Bid specific ATC.pdf</div></div>	

UNPRICED BID – B7, B16 & COMMERCIAL GRADE FASTENERS

Schedule	Item No	Material code	Material description	Material Specification	Qty in Nos	Applicable Drawing number	Quoted / Not Quoted
Schedule 1	1	411061610000	STUD M16 X 2 X 100 SA193B16	SA 193 GR B16	116	BPS 41106, TDC:5:164	
Schedule 1 Total					116		
Schedule 2	1	411171610000	FT STUD-M16x100 -B7	SA 193 GR B7	45	BPS 41117, TDC:5:164	
Schedule 2	2	411171611000	STUD M16 X 2 X 110 SA193B7	SA 193 GR B7	54	BPS 41117, TDC:5:164	
Schedule 2	3	411171612000	FT STUD-M16x120 -B7	SA 193 GR B7	696	BPS 41117, TDC:5:164	
Schedule 2	4	411172012000	FT STUD-M20x120 -B7	SA 193 GR B7	757	BPS 41117, TDC:5:164	
Schedule 2	5	411172015000	FT STUD-M20x150 -B7	SA 193 GR B7	476	BPS 41117, TDC:5:164	
Schedule 2	6	411172414000	FT STUD-M24x140 -B7	SA 193 GR B7	92	BPS 41117, TDC:5:164	
Schedule 2	7	411172418000	FT STUD-M24x180 -B7	SA 193 GR B7	70	BPS 41117, TDC:5:164	
Schedule 2	8	411172718000	FT STUD-M27x180 -B7	SA 193 GR B7	126	BPS 41117, TDC:5:164	
Schedule 2	9	948222423700	STUD M 24 X 3 X 230 SA193B7	SA 193 GR B7	228	4-80-999-99308	
Schedule 2	10	948222723700	STUD M27X3X230 SA193GRB7	SA 193 GR B7	150	3-80-452-30043, VAR04	
Schedule 2	11	948223629700	STUD M36 X 4 X 290 SA193B7	SA 193 GR B7	28	4-80-999-99308	
Schedule 2	12	413240001600	NUT -M16 -GR7	SA 194 GR 7	288	BPS 41324, TDC:5:164	
Schedule 2	13	413240003600	Hex Nut M36x3-BPS 41324/04	SA 194 GR 7	12	BPS 41324, TDC:5:164	
Schedule 2	14	413244003600	HEX NUT M36 X 4 SA194GR7	SA 194 GR 7	4304	4-80-999-99045, TDC:5:164	
Schedule 2	15	413244005600	HEX NUT M56 X 4 SA194GR7	SA 194 GR 7	156	4-80-999-99045, TDC:5:164	
Schedule 2	16	413245004800	HEX NUT M48 X 5 SA194GR7	SA 194 GR 7	343	4-80-999-99045, TDC:5:164	
Schedule 2 Total					7825		

For Company Name:

Seal:

Signature:

UNPRICED BID – B7, B16 & COMMERCIAL GRADE FASTENERS

Schedule	Item No	Material code	Material description	Material Specification	Qty in Nos	Applicable Drawing number	Quoted / Not Quoted
Schedule 3	1	412152010002	HEX BOLT M20X100 (GALVANISED) IS1367	Property Class 6.8	200	BPS 41215	
Schedule 3	2	412152412000	BOLT-M24x120 -6.8-IS1364P1	Property Class 6.8	100	BPS 41215	
Schedule 3	3	412152712000	HEX BOLT M27X3X120 P CL 6.8 GR A STEEL	Property Class 6.8	548	BPS 41215	
Schedule 3	4	412211612000	BOLT-M16x120 -4.6-IS1363P1	Property Class 4.6	16	BPS 41221	
Schedule 3	5	412212009000	BOLT-M20x90 -4.6-IS1363P1 BPS 41221	Property Class 4.6	645	BPS 41221	
Schedule 3	6	413010002002	HEX NUT M20 (GALVANISED)P CL 6	Property Class 6	200	BPS 41301	
Schedule 3	7	413040001000	NUT -M10 -CL4-IS1363P3	Property Class 4	23564	BPS 41304	
Schedule 3	8	413040002000	NUT -M20 -CL4-IS1363P3	Property Class 4	13141	BPS 41304	
Schedule 3	9	413040002400	NUT -M24 -CL4-IS1363P3	Property Class 4	26	BPS 41304	
Schedule 3	10	413040005600	BL HEX NUT M 56 X 4 P CL.4 GR C STEEL	Property Class 4	331	BPS 41304	
Schedule 3	11	413190002400	Hex Nut Gr B M24 T425 BPS 41319	SA 194-2H	746	BPS 41319, TDC:5:164	
Schedule 3	12	413190003000	NUT -M30 -2H	SA 194-2H	880	BPS 41319, TDC:5:164	
Schedule 3	13	413193003600	NUT -M36x3 -2H	SA 194-2H	650	BPS 41319, TDC:5:164	
Schedule 3	14	413195004800	HEX NUT M48 X 5 SA194GR2H	SA 194-2H	27	4-80-999-99290, TDC:5:164	
Schedule 3	15	413950052000	HEX NUT M52 X 5 SA194GR2H	SA 194-2H	600	BPS 41319, TDC:5:164, 4-80-363-84522-R00	
Schedule 3	16	414080003000	PUNCHED WASHER A 33 IS:2016/LATEST	As per IS 2016 (latest)	472	BPS 41408	
Schedule 3	17	414080007200	PUNCHED WASHER A 78(ID)- IS:2016	As per IS 2016 (latest)	105	BPS 41408	
Schedule 3	18	417041006300	SPLIT PIN 10x63 IS:549	As per IS 549 (latest)	556	BPS 41704	
Schedule 3	19	417044002500	SPLIT PIN-4x25 -IS:549	As per IS 549 (latest)	240	BPS 41704	
Schedule 3	20	417046304500	SPLIT PIN-6.3x45 -IS:549	As per IS 549 (latest)	764	BPS 41704	

Schedule 3 Total**43811****Grand Total****51752**

For Company Name:

Seal:

Signature:

PRE – QUALIFICATION REQUIREMENT (PQR) FOR SUPPLY OF B7, B16 & COMMERCIAL GRADE FASTENERS

SI No.	PQR Description	Documents to be submitted	** Bidder response (Submitted / Not submitted)
1	Bidder shall be manufacturer . Bids from Traders / distributors / dealers are not acceptable.	Any one of the following documents may be considered as valid proof as Manufacturer: a. Valid ISO 9001:2015 certificate b. Udyam Registration c. Factory License	
2	Experience in supplying the product/s: Bidder shall have prior experience in manufacture and supply of fasteners for the tendered specifications (B7, B16, Commercial Grades). The experience shall be counted 4 years prior to the date of Enquiry.	For fulfilling the experience criteria any one of the following documents may be considered as valid proof for meeting the experience criteria: a. One or more purchase order/s of B7, B16, Commercial Grade fasteners relevant to the quoted schedule along with relevant drawings from any customer. PO date should be 27.04.2018 or afterwards. The invoice copy w.r.t submitted PO are also required as proof of order completion. b. Execution certificate by client with order value. c. Any other document in support of order execution like Third Party Inspection release note etc.,	
3	FINANCIAL SOUNDNESS: Bidder should have made a turnover of at least Rs. 6 lakhs for anyone of last 4 audited Financial Years. Start-up which has commenced operations only in the current Financial year (FY 2022-23) but meeting financial turnover criteria shall submit certificate from CA certifying the turnover made up to the current month of FY (FY 2022-23).	Audited Balance Sheet and Audited Profit & Loss Account for the past four financial years. In case bidders have commenced operations within the past 4 years from the date of enquiry, audited Balance Sheet and P&L statement for the available years shall be submitted.	

***Supporting documents to be enclosed without fail.**

Note –

- Bids fulfilling the above criteria will be considered for further techno-commercial evaluation.
- For Startups and MSE bidders, Annual Financial Turnover criteria (Sl. No: 3 above) is relaxed by 50%, during anyone of the Financial years in the past 4 years and prior experience criteria (Sl. No: 2 above) is relaxed to last 5 years from the date of Enquiry. Relaxation is subject to bidder meeting technical and quality criteria of the PQR. Bidders proposing to avail relaxation as above need to submit necessary document proof along with Pre-Qualification bid.
 - Startups - Certificate of Recognition by Department of Industrial Policy & Promotion
 - MSE – Udyam Registration certificate
- Bidder to submit all supporting documents in English language. If documents submitted by bidder are in a language other than English, a self-attested English translated document shall also be submitted.
- Bidders referred to NCLT, NCLAT or firms having strictures / hold by any other Government agency will not be considered.

For Company Name:

Signature:

Seal:

**Declaration format for Make in India to be issued on Bidder's Company letter head –
SUPPLY OF B7, B16 & COMMERCIAL GRADE FASTENERS**

Self-Declaration

Enquiry No.	
Enquiry Date	

In line with Government public procurement order Number P45021/2/2017-B.E-II dated 15.06.2017, and further modified order dt. 28.05.2018 & order 04.06.2020 issued by DPIIT.

I / We hereby declare that I / We are a “Local Supplier” meeting the requirement of minimum local content (.....%) defined in the above government notification for the goods against above mentioned enquiry Number.

Details of location at which local value addition will be made is as follows:

Door No.	
Street / Address 1	
Street / Address 2	
District	
State	
Country	
PIN Code	

We also understand that the false declarations will be considered as breach of Integrity and liable for action.

For Company Name:

Seal:

Signature:

Date:

Place:

(Please fill all the yellow colour fields)

BHARAT HEAVY ELECTRICALS LIMITED
PIPING CENTRE, PURCHASE
BHEL / CHENNAI – 600 017

THIRD PARTY NON-DISCLOSURE AGREEMENT

I, _____, on behalf of the _____ (Name of Company), acknowledge that the information received or generated, directly or indirectly, while working with BHEL, Piping Centre, Chennai on contract is confidential and that the nature of the business of the BHEL, Piping Centre, Chennai is such that the following conditions are reasonable, and therefore:

I warrant and agree as follows:

I, or any other personnel employed or engaged by our company, agree not to disclose, directly or indirectly, any information related to the BHEL, Piping Centre, Chennai Without restricting the generality of the foregoing, it is agreed that we will not disclose such information consisting but not necessarily limited to:

- Technical information: Methods, drawings, processes, formulae, compositions, systems, techniques, inventions, computer programs/data/configuration and research projects.
- Business information: Customer lists, project schedules, pricing data, estimates, financial or marketing data.

On conclusion of contract, I, or any other personnel employed or engaged by our company shall return to BHEL, Piping Centre, Chennai all documents and property of BHEL, Piping Centre, Chennai, including: drawings, blueprints, reports, manuals, computer programs/data/configuration, and all other materials and all copies thereof relating in any way to BHEL, Piping Centre, Chennai's business, or in any way obtained by me during the course of contract. I further agree that I, or any others employed or engaged by our company shall not retain copies, notes or abstracts of the foregoing.

This obligation of confidence shall continue after the conclusion of the contract also.

I acknowledge that the aforesaid restrictions are necessary and fundamental to the business of the BHEL, Piping Centre, Chennai and are reasonable given the nature of the business carried on by the BHEL, Piping Centre, Chennai I agree that this agreement shall be governed by and construed in accordance with the laws of country.

I enter into this agreement totally voluntarily, with full knowledge of its meaning, and without duress.

Dated at _____, this ____ day of _____, 20__.

Name

Company

Signature

CHECK LIST – SUPPLY OF B7, B16 & COMMERCIAL GRADE FASTENERS

NOTE: - Tenderers are required to fill in the following details and no column should be left blank

1	Name and Address of the Bidder		
2	Details about type of the Firm/Company	Proprietorship / Partnership / Private / Others	
3.a	Details of Contact person for this Tender	Name : Mr/Ms Designation: Telephone No: Mobile No: Email ID: Fax No:	
3.b	Details of alternate Contact person for this Tender	Name : Mr/Ms Designation: Telephone No: Mobile No: Email ID: Fax No:	
		APPLICABILITY (BY BHEL)	ENCLOSED / AGREED BY BIDDER
4	Whether the format for compliance with PRE QUALIFICATION CRITERIA (Annexure-C) is understood and filled with proper supporting documents referenced in the specified format?	Applicable	YES/NO
5	Audited Balance sheet, Profit and Loss Account for the last FOUR years	Applicable	YES/NO
6	Whether all pages of the Tender documents including annexures, appendices etc. are read and understood? Signed copy of Annexure-A enclosed?	Applicable	YES/NO
7	Whether duly filled and signed unpriced bid Annexure-B enclosed?	Applicable	YES/NO
8	Whether MII Purchase preference applicable? If Yes, duly filled and signed Annexure-D enclosed?	Applicable	YES/NO
9	Whether MSE Purchase Preference Applicable? If Yes, whether Udyam Registration certificate enclosed?	Applicable	YES/NO
10	Whether signed NDA format (Annexure-E) enclosed?	Applicable	YES/NO
11	Copy of PAN Card & GST Registration Certificate	Applicable	YES/NO
12	Bank Account Details for E-Payment	Applicable	YES/NO

NOTE: STRIKE OFF 'YES' OR 'NO', AS APPLICABLE. TENDER NOT ACCOMPANIED BY THE PRESCRIBED ABOVE APPLICABLE DOCUMENTS ARE LIABLE FOR REJECTION.

DATE:

AUTHORISED SIGNATORY

(With Name, Designation and Company seal)

DRAWING No
3-80-452-30043

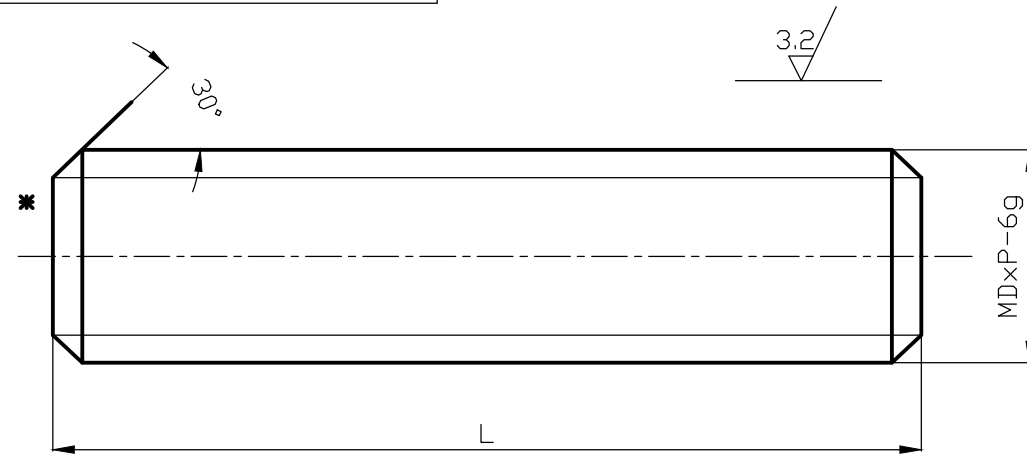

NOTES

01. MATERIAL IDENTIFICATION MARK 'B7' SHALL BE PUNCHED ON ANY ONE SIDE, AS MARKED WITH *.
02. ALL OTHER DIMENSIONS TO BE AS PER IS 1367

VAR No.	MDxP	L	MATERIAL CODE	WEIGHT kg	MATERIAL	
01	M16X2	140	948221614700	0.190	SA193B7	
02	M12X1.75	100	948221210700	0.100	SA193B7	
03	M27X3	200	948222720700	1.150	SA193B7	
04	M27X3	230	948222723700	1.230	SA193B7	
05	M27X3	280	948222728700	1.950	SA193B7	
06	M30X3.5	200	948223020700	1.100	SA193B7	
07	M33X3.5	180	948223318700	1.200	SA193B7	
08	M33X3.5	260	948223326700	1.750	SA193B7	
09	M39X3	320	948223932700	3.000	SA193B7	
10	M39X3	370	948223937700	3.500	SA193B7	
11	M48X5	380	948224838700	5.400	SA193B7	
12	M56X4	460	948225646700	8.800	SA193B7	
△	13	M42X4.5	300	948224230700	2.618	SA193B7
△	14	M30X3.5	300	948220430000	1.560	SA193B7

CAUTION THE INFORMATION ON THIS DOCUMENT IS THE PROPERTY OF BHARAT HEAVY ELECTRICALS LIMITED. IT MUST NOT BE USED DIRECTLY OR INDIRECTLY IN ANY WAY DETRIMENTAL TO THE INTEREST OF THE COMPANY

TYPE OF PRODUCT
OR NAME OF
CUSTOMER/PROJECT



BHARAT HEAVY ELECTRICALS LTD.,
PIPING CENTRE,
CHENNAI 600 017

DRN	NAME	SIGN	DATE	NO OF ITEMS
	G.DINESH	-sd-	24.10.12	
CHD	S.RAMAMURTHY	-sd-	24.10.12	
APPD	K.V.RAMANI	-sd-	24.10.12	

REV	DATE	ALTERED	RPS
01	18.09.19	APPROVED	IDBR
ZONE VAR.13-14 ADDED			
REVISIONS MARKED AS △			

DEPT.	GRADE OF UN TOL. DIM	SCALE	WEIGHT (Kg).	REF TO ASSY / OLD DRG	ITEM No.
	C/M/F	N.T.S			
TITLE			CARD CODE	DRAWING No.	REV
STUD SA193 GRB7			U 01	3-80-452-30043	01

CAUTION: The information on this document is the property of BHARAT HEAVY ELECTRICALS LTD. It must not be used directly or indirectly in any way detrimental to the interest of the company.

REV	DATE	ALTERED
		APPROVED

ALL DIMENSIONS ARE IN MILLIMETRES

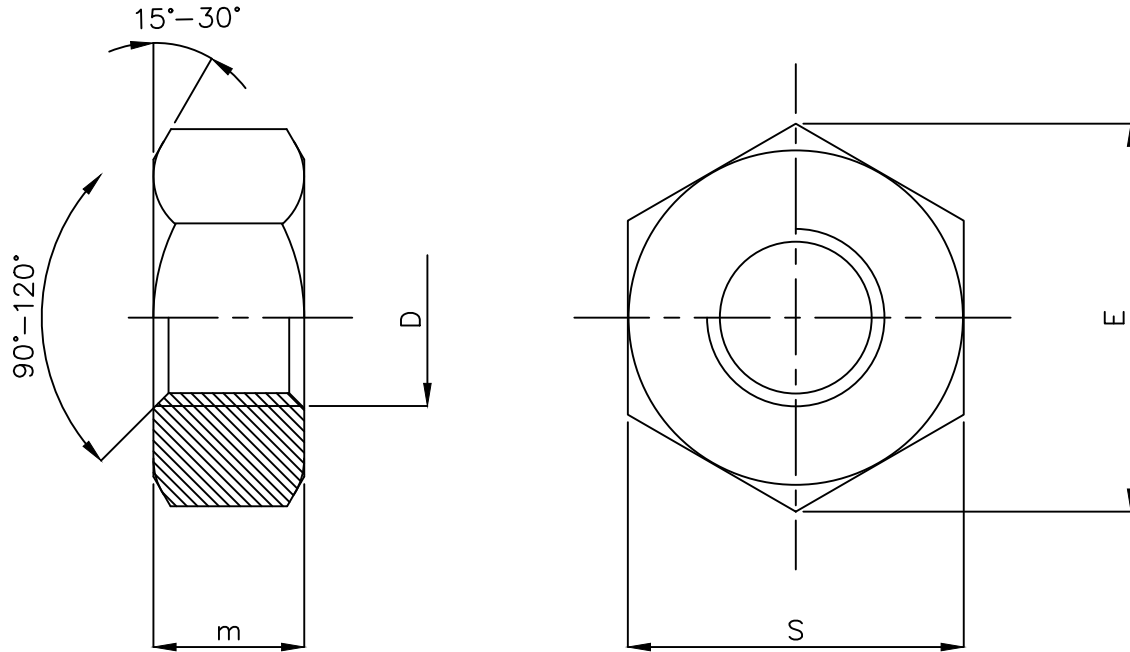

VAR. NO.	THREAD SIZE D	E	m	S
01	(M52 X 5)	89	52	79

NOTES:

01 THE NUT SHALL MEET OTHER TECHNICAL REQUIREMENTS AS PER BPS 41319.

01	HEX. NUT M52X5	413950052000			1	550
		SA194 GR2H				
VAR NO.	DESCRIPTION	STD	MATL. CODE	A	UNIT	UNIT.WT.(Kg)
			MATL. SPECN.	C	DI	QTY.

	BHARAT HEAVY ELECTRICALS LIMITED PIPING CENTRE CHENNAI 600 017		DRN	R.BHARATH	SIGN	DATE	NO.OF VAR
			CHD	IDB RAJU		25.02.22	
			APPD	IDB RAJU		25.02.22	
DEPT	GRADE OF UNTOL. DIM		SCALE	WEIGHT (KG).	REF. TO ASSY./OLD DRG.	ITEM NO.	NO. OF ITEMS
CODE	C / M / F		N.T.S	1.550			
TITLE				CARD CODE	DRAWING NO.		REV
HEX. NUT M52X5				U 01	4-80-363-84522		00

FIRST ANGLE PROJECTION (ALL DIMENSIONS IN MILLIMETRES)

REV	DATE	ALTERED	REV	DATE	ALTERED
01	26/04/88	CHECKED <i>S. Anand</i>	02	17/6	CHECKED <i>dia</i>
MATERIAL SPECN. & MATERIAL CODE CHANGED			VAR NO. 07 ADDED		

F

REV	DATE	ALTD	DRG
03	20/2/89	CHKD	S.J.K.
HEIGHT OF NUTS 'm' ALTERED ('m' & 'Md'). TOLERANCE COMMONLY CHANGED AS '6H' FOR ALL NUTS. NOTES 1 TO 3 ADDED. WEIGHT ALTERED.			

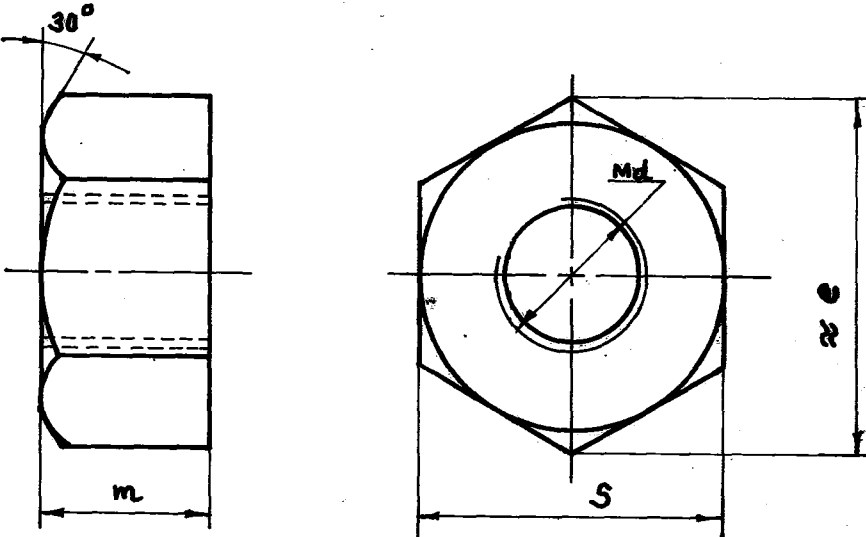

CAUTION: THIS INFORMATION ON THIS DOCUMENT IS THE PROPERTY OF BHARAT HEAVY ELECTRICALS LTD. IT MUST NOT BE USED DIRECTLY OR INDIRECTLY IN ANY WAY DETRIMENTAL TO THE INTEREST OF THE COMPANY.

SIZE	VAR	m	s	e	WT/PIECE	MATL. CODE	THREAD (INTERNAL)
Md-7H	NO.			≈	IN KG.	MATL. SPECN.	TOLERANCE
M42x4.5	01	42	65	75.1	0.81	413-24-45042 SA 194 Gr 7	6H
M64x4	02	64	95	110.0	2.26	413-24-40064 SA 194 Gr 7	6H
M68x4	03	68	100	115.0	2.79	413-24-40068 SA 194 Gr 7	6H
M48x5	04	48	75	86.5	1.24	413-24-50048 SA 194 Gr 7	6H
M36x4	05	36	55	60.79	0.43	413-24-40036 SA 194 Gr 7	6H
M56x4	06	56	85	98.0	1.76	413-24-40056 SA 194 Gr 7	6H
M72x6	07	72	105	121.0	3.24	413-24-60072 SA 194 Gr 7	6H

- NOTES:
- METRIC SCREW THREADS AS PER IS 4218.
 - TECHNICAL DELIVERY CONDITIONS, MANUFACTURE AND WORKMANSHIP AS PER IS 1367.
 - NUTS SHALL BE STAMPED ON ANY ONE FACE TO INDICATE THE GRADE & PROCESS OF MANUFACTURE.
'7' FOR HOT FORGED/COLD PUNCHED NUTS. '7B' FOR NUTS MACHINED FROM BAR STOCK

BHARAT HEAVY ELECTRICALS LTD. BOILER PLANT UNIT TIRUCHIRAPALLI- 620 014.	DRN.	NAME	SIGN	DATE
	CHD.	M. PUGAZH	H. [Signature]	30/11/87
	APPD.	[Signature]		

DEPT.	GRADE OF UNTO DIM	SCALE	WEIGHT (Kg)	REF TO ASSY/OLD DRG	ITEM No.
CODE	01M/F				

TITLE	CARD CODE	DRAWING No.
HEX. NUT		4-80-999-99045

REV 01	DATE 10/8/89	ALTERED APPROVED	REV 02	DATE	ALTERED APPROVED
NOTE-04 DELETED.					

CAUTION: THIS INFORMATION IS THE PROPERTY OF BHARAT HEAVY ELECTRICALS LTD. IT MUST NOT BE USED DIRECTLY OR INDIRECTLY IN ANY WAY DETRIMENTAL TO THE INTEREST OF THE COMPANY

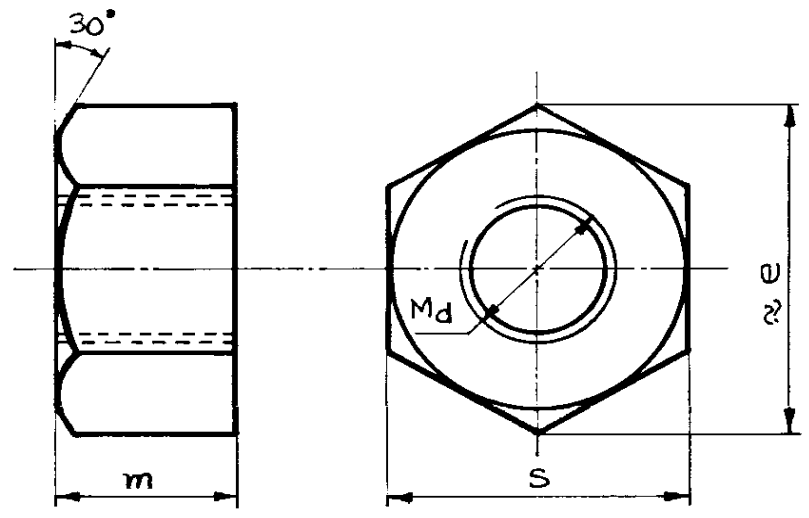

VAR NO.	SIZE Md	m	S	± e	THREAD (INTERNAL) TOLERANCE	WEIGHT (kg)	BIN CODE	REMARKS
01	M 36x4	36	55	60-79	6H	0.43	413-19-40036	
02	M 42x4.5	42	65	75.1	6H	0.81	41319-45042	
03	M 48x5	48	75	86.5	6H	1.24	41319-50048	
04	M 56x4	56	85	98.0	6H	1.76	41319-40056	
05	M 64x4	64	95	110.0	6H	2.46	41319-40064	
06	M 68x4	68	100	115.0	6H	2.79	41319-40068	
07	M 72x4	72	105	121.0	6H	3.24	41319-40072	

NOTES:—

01. MATERIAL : SA 194 GR 2H(C)
02. METRIC SCREW THREADS AS PER IS 4218.
03. TECHNICAL DELIVERY CONDITIONS, MANUFACTURE AND WORKMANSHIP AS PER IS 1367.
04. ~~NUTS SHALL COMPLY WITH Q-C-P 2:7:048~~
05. NUTS SHALL BE STAMPED WITH THE FOLLOWING MARKING ON ANY ONE FACE TO INDICATE THE GRADE & PROCESS OF MANUFACTURE.
'2H' FOR HOT FORGED/COLD PUNCHED NUTS. 2HB FOR NUTS MACHINED FROM BAR STOCK.



BHARAT HEAVY ELECTRICALS LTD.
BOILER PLANT UNIT
TRUCHIRAPALLI-620 014.

DFN	NAME D. HARIKRISHNAN	SIGN	DATE 11/12/1989
CHD	RANANTH	SIGN	
APP	S. JAYAKUMAR	SIGN	19/12/89

EPT.	GRADE OF UNTOLE DIM. C.M.F.	SCALE N.T.S.	WEIGHT (K) REFER TABLE	REF TO ASS/OLD DRG
------	-----------------------------	--------------	------------------------	--------------------

TITLE **HEX. NUT (CS)** 4-80-999-99290 01

CAUTION: THIS INFORMATION ON THIS DOCUMENT IS THE PROPERTY OF BHARAT HEAVY ELECTRICALS LTD. IT MUST NOT BE USED DIRECTLY OR INDIRECTLY IN ANY WAY DETRIMENTAL TO THE INTEREST OF THE COMPANY.

REV 01	DATE 4.5.90	ALTERED: H. M. Narayan	REV 02	DATE 1.8.90	ALTERED: R. SRINIVASAN	REV 03	DATE 28.8.90	ALTERED: R. SRINIVASAN
CHECKED: <i>[Signature]</i>			CHECKED: <i>[Signature]</i>			CHECKED: <i>[Signature]</i>		

'8g' changed to '6g' var. nos. 05 to 07 added. MATL CODE CHANGED FOR VAR. 01 DRG RETRACED FOR ADDING VAR. 01

NOTE NO.04 ADDED. VAR. NO.08 & 09 ADDED.

'Z' DIMENSION CHANGED FOR VAR. NOS.01,02 & 03!

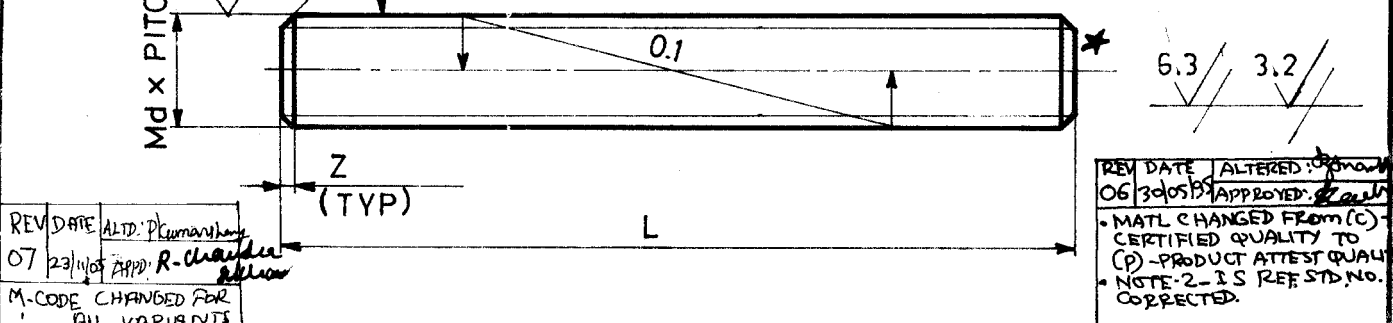

VAR. NO.	Md x PITCH	L	Z	MATL. CODE BIN. CODE	MATL. SPEC.	Wt. -Kg-	REMARKS
01	M20 x 2.5	160	2.5	15 039 086 94 822 20 16 700	SA.193 B7(P)	0.336	01 05
02	M24 x 3.0	230	3.0	15-039-086 94 822 24 23 700		0.690	03 04
03	M30 x 3.5	230	3.5	15-039-087 94 822 30 23 700		1.104	05
04	M36 x 4.0	290	4.0	15-039-116 94 822 36 29 700		2.001	
05	M12 x 1.75	140	1.75	15-039-115 94 822 12 14 700		0.112	07
06	M16 x 2.0	160	2.0	15-039-086 94 822 16 16 700		0.224	01 04
07	M20 x 2.5	190	2.5	15-039-086 94 822 20 19 700		0.400	
08	M20 x 2.5	225	2.5	15-039-086 94 822 20 23 700		0.470	
09	M16 x 2.0	200	2.0	15-039-086 94 822 16 20 700		0.280	02

NOTES.

- REFER IS-1367 FOR TECHNICAL DELIVERY CONDITION FOR THREADED STEEL FASTENERS.
- REFER IS-4218 FOR ISO METRIC SCREW THREADS.
- MATERIAL IDENTIFICATION MARK 'B-7' SHOULD BE PUNCHED ON ANY ONE SIDE, AS MARKED WITH *
- T.S. AND HARDNESS SHALL NOT BE LESS THAN 860 N/mm² AND 250 HB.

BHARAT HEAVY ELECTRICALS LTD. BOILER PLANT UNIT TIRUCHIRAPALLI-620014.		DRN.	NAME	SIGN	DATE
			N. M. Nathan	H. M. Narayan	04.05.90
		CHD.	M. M. Mani		
		APPD.	S. Jayakumar	<i>[Signature]</i>	5/5/90
DEPT. CODE	GRADE OF UNTOL DIM C/M/F	SCALE	WEIGHT (Kg)	REF TO ASSY/OLD DRG	
TITLE	STUD		CARD CODE	DRAWING No.	REV.
			U 01	4-80-999-99308	



PLANT STANDARD

HPBP TIRUCHIRAPPALLI

BPS 41106

Rev. No. 03

PAGE 1 OF 3

STUD BOLTS FOR HIGH TEMPERATURE USE

(For Temperature of Medium 425°-550°C)

1.0 SCOPE:

Covers the requirements for Stud Bolts for use in temperature of medium 425°C to 550°C in the size range M12 to M33.

2.0 SPECIFICATION AND REFERENCE STANDARDS:

Dimensions and preferred sizes	Table 1 of this standard	
Preferred length size combination	Table 2 of this standard	
Tolerance	Product Grade	A
	Indian Standard	IS:1367 (Part 2)
Thread	Pitch	Table 1 of this Standard
	Tolerance	T according to TP 023 18 96
Material	Steel according to ASTM A 193 B16 Certified in heat treated condition	
Manufacture	Thread rolling upto M 24	
Mechanical Properties	As specified in ASTM A 193 B16	
Marking	All studs shall be stamped 'B16' on any one side	
General Requirements	Studs shall comply with TDC:5:164 in respect of requirements not covered in this standard except for Cadmium plating	

2.1 Referred Standards (Only current versions are applicable)

IS: 1367 (Part-2) Technical supply conditions for threaded steel fasteners.

ASTM-A193 Specification for alloy steel and stainless bolting material for high temperature service

TP 023 18 96 Tolerances for ISO metric screw threads for high temperature application-external.

TDC:5:164 TDC for studs to ASTM A193 Gr B7 and ASTM A193 Gr B16.

Revisions

Brought upto date

Approved

STANDARDS SECTION
CONTRACT ENGINEERING AND CO-ORDINATION
HPBP, TIRUCHIRAPPALLI

Rev. No. 03

Amd. No.

Reaffirmed

Prepared

Issued

Dt of 1st Issue

Dt. 19-12-97

Dt.

Year

STANDARDS

STANDARDS

DEC 1976

COPYRIGHT AND CONFIDENTIAL

The information on this document is the property of BHARAT HEAVY ELECTRICALS LIMITED. It must not be used directly or indirectly in any way detrimental to the interest of the company.



PLANT STANDARD

HPBP TIRUCHIRAPPALLI

BPS 41106

Rev. No. 03

PAGE 2 of 3

3.0 DESIGNATION:

A Grade A Stud to this standard of thread size M12 and nominal length 60 mm shall be designated as:

3.1 On Drawings:

- i) Material Specification column: A 193 B-16
- ii) Description Column : STUD BOLT A T425-550 M12X60
- iii) Drawing Number Column : 4110612060
- iv) Material Code Column : 4110612060

3.2 Ordering Description:

For placing indents, issuing enquiries and on purchase order, the Ordering Description given below shall be followed.

Stud Bolt M12x60 BPS:41106-A-ASTM-A193-B16

4.0 ADDITIONAL INFORMATION:

4.1 Copies of the following Standards shall be enclosed along with Purchase Order.

- 1. TDC:5:164
- 2. TP 023 18 96
- 3. BPS:41106

12.5 (0.8/3.2)

TABLE 1 - DIMENSIONS FOR STUD BOLTS.

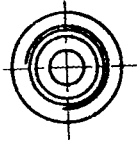
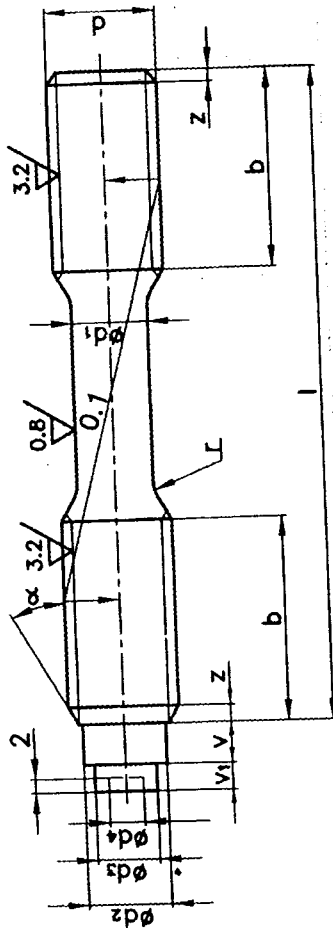

TABLE 2 - PREFERRED LENGTH SIZE COMBINATION FOR STUD BOLTS

NOMINAL LENGTH l	M12	M16	M20	M24	M30	(M33)
60	41.9					
70		98.2				
80						
90						
100		127				
110			216.6			
120				332.8		
140					261.1	
160						417.2
180						
200						
220						
240						

THREAD SIZE d	d1	d2	d3	d4	b	Z MAX.	v	v1	r	α
M12	9	8	6	4	25	2.2	4	3	20	30°
M16	12.5	12	9	7	30	2.5	6	4	20	30°
M20	15.5	14	11	8	35	3	8	4	20	30°
M24	18.5	14	11	8	40	3.5	8	4	30	30°
M30	23.5	18	14	11	50	4	10	4	30	45°
(M33)	26.5	25	19	14	55	4	10	4	30	45°

NOTE:-

1. ALL DIMENSIONS ARE IN MM
2. SIZES IN BRACKETS ARE NON-PREFERRED
3. PREFERRED LENGTHS ARE BETWEEN THE BOLD STEPPED LINES.
4. WEIGHTS ARE GIVEN IN KG PER 1000 NUMBERS ONLY.
5. FOR STOCKED SIZES REFER BPS COMPONENTS BOOKLET.
6. FOR TOLERANCE FOR UNTOLERANCED DIMENSIONS, REFER TP 023 0299.



PLANT STANDARD

HPBP TIRUCHIRAPALLI

BPS: 41704

PAGE 1 OF 4

Based on IS: 549-1974

SPLIT PINS

1.0 SCOPE

Covers the requirements for Split Pins in the diameter range 0.6 to 20mm.

2.0 SPECIFICATION AND REFERENCE STANDARDS

Dimensions and tolerances	Table 1 of this standard	
Preferred length and size combination	Table 2 of this standard	
Material	Mild Steel Wire (Half round)	
Finish	Bright self colour finish	
Sampling and Acceptability	Indian standard	IS: 6821
	General requirements	
Pins shall comply with IS: 549 in respect of requirements not covered in this standard		

2.1 Referred Standards (Only the current versions are applicable)

IS: 549 Specification for Split Pins.

IS: 6821 Methods for sampling non-threaded fasteners

COPYRIGHT AND CONFIDENTIAL

The information on this document is the property of BHARAT HEAVY ELECTRICALS LIMITED. It must not be used directly or indirectly in any way detrimental to the interest of the company.

REVISIONS

DATE

APPROVED

STANDARDS SECTION
ENGINEERING AND DEVELOPMENT CENTRE
HPBP TIRUCHIRAPALLI

PREPARED

HPBP TIRUCHY

ISSUED

STANDARDS
ENGG

DATE

DEC 1986



PLANT STANDARD

HPBP TIRUCHIRAPALLI

BPS: 41704

PAGE 2 OF 4

3.0 DESIGNATION

A Split Pin to this standard of nominal diameter 5mm and nominal length 56mm shall be designated as:

3.1 On Drawings:

- i) Material Specification column: IS: 549
- ii) Description column : PIN SPLIT 5x56
- iii) Drawing Number column : 4170405056
- iv) Material Code column : 4170450056

3.2 Ordering Description

For placing indents, issuing enquiries and on purchase order, the Ordering Description given below shall be followed.

Split Pin 5x56 IS: 549

COPYRIGHT AND CONFIDENTIAL

The information on this document is the property of BHARAT HEAVY ELECTRICALS LIMITED. It must not be used directly or indirectly in any way detrimental to the interest of the company.

DEC 1986

74



PLANT STANDARD

HPBP TIRUCHIRAPALLI

BPS: 41704

PAGE 3 OF 4

COPYRIGHT AND CONFIDENTIAL

The information on this document is the property of BHARAT HEAVY ELECTRICALS LIMITED. It must not be used directly or indirectly in any way detrimental to the interest of the company.

TABLE 1 - DIMENSIONS FOR SPLIT PINS
(All dimensions in millimetres)

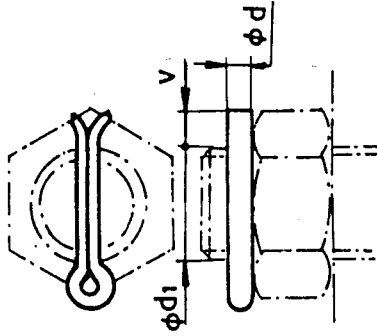
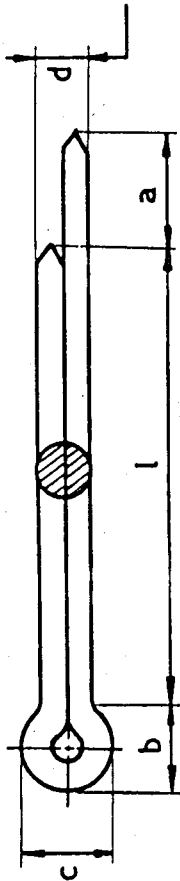

Dimensions	Nominal size	0.6	0.8	1.0	1.2	1.6	2.0	2.5	3.2	4.0	5.0	6.3	8.0	10	15	16	20
d	Max	0.5	0.7	0.9	1.0	1.4	1.8	2.3	2.9	3.7	4.6	5.9	7.5	9.5	12.4	15.4	19.3
	Min	0.4	0.6	0.8	0.9	1.3	1.7	2.1	2.7	3.5	4.4	5.7	7.3	9.3	12.1	15.1	19.0
a	Max	1.6	1.6	1.6	2.5	2.5	2.5	2.5	3.2	4.0	4.0	4.0	4.0	6.3	6.3	6.3	6.3
	≈	2.0	2.4	3.0	3.0	3.2	4.0	5.0	6.4	8.0	10	12.6	16	20	26	32	40
c	Max	1.0	1.4	1.8	2.0	2.8	3.6	4.6	5.8	7.4	9.2	11.8	15	19	24.8	30.8	38.6
	Min	0.9	1.2	1.6	1.7	2.4	3.2	4.0	5.1	6.5	8.0	10.3	13.1	16.6	21.7	27.0	33.8
Corres-ponding dia-meter d ₁	Over	--	2.5	3.5	4.5	5.5	7.0	9.0	11	14	20	27	39	56	80	120	170
	Up to	2.5	3.5	4.5	5.5	7.0	9.0	11	14	20	27	39	56	80	120	170	--
v	Over	--	2	3	4	5	6	8	9	12	17	23	29	44	69	110	160
	Up to	2	3	4	5	6	8	9	12	17	23	29	44	69	110	160	--
		3	3	4	5	5	6	6	8	8	10	12	14	16	20	25	32



PLANT STANDARD

HPBP TIRUCHIRAPALLI

BPS: 41704

PAGE 4 OF 4

TABLE 2 - PREFERRED LENGTH-SIZE COMBINATION FOR SPLIT PINS

(All dimensions in millimetres)

l Nom +1/2 IT 17	Nominal size																
	0.6	0.8	1.0	1.2	1.6	2.0	2.5	3.2	4.0	5.0	6.3	8.0	10	13	16	20	
4																	
5																	
6																	
8																	
10																	
12																	
14						0.4											
16																	
18																	
20																	
22									2.7								
25																	
28										5.5							
32									3.6								
36										6.5							
40									4.6		11.6						
45																	
50									5.6	8.4	13.4						
56										9.2							
63											17.2						
71																	
80																	
90																	
100																	
112																	
125																	
140																	
160																	
180																	
200																	
224																	
250																	
280																	

WEIGHTS

COPYRIGHT AND CONFIDENTIAL
 The information on this document is the property of BHARAT HEAVY ELECTRICALS LIMITED.
 It must not be used directly or indirectly in any way detrimental to the interest of the company.

- NOTE:**
- Weights are given in kg per 1000 numbers only
 - For stocked sizes refer BPS components booklet
 - Preferred lengths are in between the stepped bold lines



PLANT STANDARD

HPBP TIRUCHIRAPPALLI

BPS 41117

Rev. No. 02

PAGE 1 OF 2

STUD BOLTS FOR TEMPERATURE USE

(For medium of Temperature upto 425°C)

1.0 SCOPE

Covers the requirements for Stud Bolts for use in medium of temperature 425°C in the size range M12 to M39x3.

2.0 SPECIFICATION AND REFERENCE STANDARDS

Dimensions and preferred sizes	Fig 1 & Table 1 of this standard	
Preferred length size combination	Table 1 of this standard	
Tolerance	Product grade	A
	Indian Standard	IS: 1367 (Part 2)
Thread	Pitch	Table 1 of this standard
	Tolerance	6g
	Indian Standard	IS 4218 (Part 3, 5 & 6)
Material	Steel according to ASTM A193 - B7 Certified in quenched and tempered condition	
Manufacture	Thread rolling up to M24	
Mechanical Properties	As specified in ASTM A193-B7	
Marking	All studs shall be stamped B7 on any one side	
General requirements	Studs shall comply with TDC:5:164 in respect of requirements not covered in this standard except for cadmium plating.	

2.1 Referred standards (Only current versions are applicable)

IS 1367 Part 2	Technical supply conditions for threaded steel fasteners
IS 1368	Dimensions for ends of parts with external ISO metric threads
IS 4218 Part 3,5 & 6	ISO metric screw threads
ASTM A193	Specification for alloy steel and stainless steel bolting material for high temperature service
TDC:5:164	TDC for alloy steel studs to specification ASTM SA193 Gr B7 / B7m / B16 oil field equipment

3.0 DESIGNATION

A Grade 'A' Stud to this standard of thread size M16 and nominal length 90mm shall be designated as:

3.1 On Drawings

i) Material Specification column	A193 - B7
ii) Description Column	STUD BOLT GR A T425 M16x90
iii) Drawing Number Column	BPS 41117
iv) Material Code column:	4111716090

Revisions			Approved		
Brought upto date			STANDARDS SECTION CONTRACT ENGINEERING AND CO-ORDINATION HPBP, TIRUCHIRAPPALLI		
Rev. No. 02	Amd. No.	Reaffirmed	Prepared	Issued	Dt of 1st Issue
Dt. JUN. 1997	Dt.	Year	STANDARDS	STANDARDS	DEC 1986

COPYRIGHT AND CONFIDENTIAL

The information on this document is the property of BHARAT HEAVY ELECTRICALS LIMITED. It must not be used directly or indirectly in any way detrimental to the interest of the company.



PLANT STANDARD

HPBP TIRUCHIRAPPALLI

BPS 41117

Rev. No. 02

PAGE 2 OF 2

3.2 Ordering Description

For placing indents, issuing enquiries and on purchase order, Ordering Description given below shall be followed.

Stud M16x90 - BPS: 41117 A - ASTM A193-B7

4.0 ADDITIONAL INFORMATION

4.1 Copies of this standard and TDC:5:164 shall be enclosed along with the purchase order

FIG. 1. DIMENSIONS FOR STUD BOLTS
(All dimensions are in millimetres)

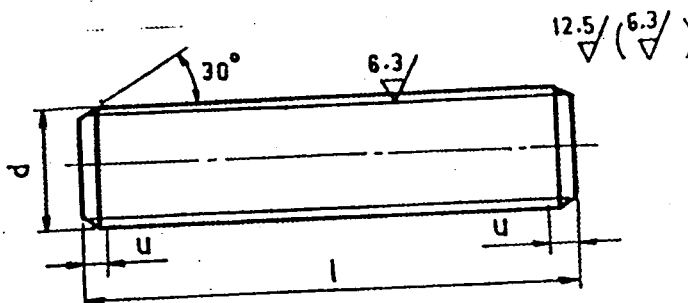

'u' according to IS:1368

TABLE 1 PREFERRED LENGTH - SIZE COMBINATION FOR STUD BOLTS
(All dimensions are in millimetres)

Thread Size d	Nominal Length (l)																		
	60	70	80	90	100	110	120	130	140	150	160	170	180	200	225	240	250	280	
	Weights																		
M12		62	70.9																357.1
M16				135.9	151.7		183.3												
M20				221.9			280.9		303					603.4					
M24							390.4			496.9				603.4					
(M27)									591.4					770.8					
M30									722.9		832.4								
(M33)														1208.6					
(M39x3)															1875.7				

Note:

1. Preferred lengths are in between the stepped bold lines
2. Weights are given in Kg per 1000 numbers only
3. Sizes in brackets are non-preferred



PLANT STANDARD

HPBP TIRUCHIRAPPALLI

BPS 41215

Rev. No. 03

PAGE 1 OF 3

HEXAGON HEAD BOLTS, PRODUCT GRADE 'B'

(Property Class 6.8)

1.0 SCOPE

Covers the requirements of hexagon head bolts in the size range M27, M33 and above.

2.0 SPECIFICATION AND REFERENCE STANDARDS

Dimensions and preferred sizes	Fig. 1 & Table 1 of this standard	
Preferred length size combination	Table 2 of this standard	
Tolerance	Product grade B	For products with $d > M24$ and $l > 10d$ or 150mm whichever is shorter
	Indian Standard	IS: 1367 (Part 2)
Thread	Pitch	Table 1 of this standard
	Tolerance	6g
	Indian Standard	IS 4218 (Part 3, 5 & 6)
Material	Steel	
Mechanical properties	Property class	6.8
	Indian Standard	IS: 1367 (Part 3)
Sampling and Acceptability	Indian Standard	IS: 1367 (Part 17)
General requirements	Bolts shall comply with IS: 1364 (Part 1) in respect of requirements not covered in this standard.	

2.1 Referred standards (Only current versions are applicable)

IS 1364 (Part 1)	Specification for hexagon head bolts, screws & nuts of product grade A&B
IS 1367 (Part 2, 3 & 17)	Technical supply conditions for threaded steel fasteners
IS 4218 (Part 3, 5 & 6)	ISO metric screw threads

3.0 DESIGNATION

A Grade 'B' Hexagon head bolt to this standard of thread size M36x3 and nominal length 180mm shall be designated as:

3.1 On Drawings

i) Material Specification column	-----
ii) Description Column	HEX BOLT GR B 6.8 M 36x3x180
iii) Drawing Number Column	BPS 41215
iv) Material Code column	4121536180

Revisions			Approved		
Brought upto date			STANDARDS SECTION PRODUCT ENGINEERING /FB HPBP, TIRUCHIRAPPALLI		
Rev. No. 03	Amd. No.	Reaffirmed	Prepared	Issued	Dt of 1st Issue
Dt. 24-07-2000	Dt.	Year	STANDARDS	STANDARDS	DEC 1986

3.2 Ordering Description

For placing indents, issuing enquiries and on purchase order, ordering description given below shall be followed. (Typical examples)

HEXAGON BOLT M27x120 to BPS:41215 - 6.8 for bolts with $d = M27$ and $M33$ and specified length
 HEXAGON BOLT M36x3x150 to BPS: 41215-6.8 for bolts with $d \geq M36 \times 3$ and specified length

4.0 ADDITIONAL INFORMATION

4.1 Copies of this standard shall be enclosed along with the purchase order for thread sizes M27, M33 and above

FIG. 1 DIMENSIONS FOR HEXAGON HEAD BOLTS
 (All dimensions are in millimetres)

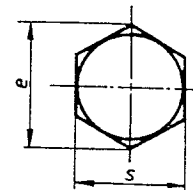
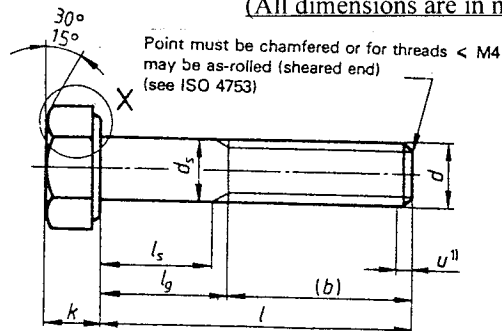

X

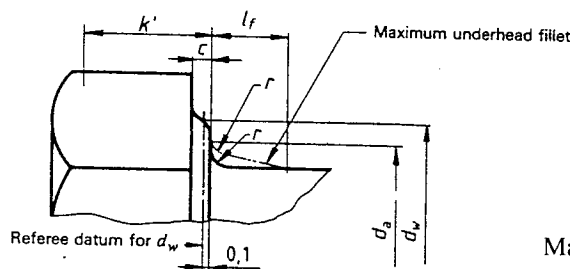

Maximum & Minimum underhead fillet
 DETAIL - X

u according to CE of IS:1368

$k' =$ Effective gauging height

$l_g \text{ Max} = l \text{ Nom} - b$, $l_s \text{ Min} = l \text{ Max} - 5 \times \text{Pitch}$

TABLE 1

(All dimensions are in millimeters)

Thread Size d	b			c		d _a Max	d _s		d _w Min		e Min		f Max	k				k' Min	r Min	S		
	1	2	3	Min	Max		Max	Min	+	++	+	++		+		++				ax	Min	
														Min	Max	Min	Max				+	++
(M27)	60	66	79	0.5 approx		30.4	27	26.67	36.9	36.9	45.20	45.20	4	16.65	17.35	16.65	17.35	11.65	1	41	40	40
(M33)	72	78	91	0.5 approx		36.4	33	32.61	45.0	45.0	55.37	55.37	6	20.58	21.42	20.58	21.42	14.40	1	50	49	49
(M36x3)	78	84	97	0.2	0.8	39.4	36	35.61	51.1	51.1	60.79	60.79	6	22.08	22.92	22.08	22.92	15.5	1	55	53.8	53.8
(M39x3)	84	90	103	0.5 approx		42.5	39	38.61	54.0	54.0	66.44	66.44	6	24.58	25.42	24.58	25.42	17.21	1	60	58.8	58.8

1) For length $l \leq 125\text{mm}$
 + For $l \leq 10d$ or 150mm ;

2) For Nom length $l > 125$ and $\leq 200\text{mm}$
 ++ For $l > 10d$ or 150mm

3) For Nom length $l > 200\text{mm}$



PLANT STANDARD

HPBP TIRUCHIRAPPALLI

BPS 41215

Rev. No. 03

PAGE 3 OF 3

TABLE - 2
PREFERRED LENGTH - SIZE COMBINATION FOR HEXAGON HEAD BOLTS
(All dimensions are in millimetres)

Nom	Length 'l'				Thread size d			
	l ≤ 10d or 150		l > 10d or 150		(M27)	(M33)	M36x3	(M39x3)
	Min	Max	Min	Max				
20	19.58	20.42						
25	24.58	25.42						
30	29.58	30.42						
35	34.5	35.5	33.75	36.25				
40	39.5	40.5	38.75	41.25				
45	44.5	45.5	43.75	46.23				
50	49.5	50.5	48.75	51.25				
55	54.4	55.6	53.5	56.5				
60	59.4	60.6	58.5	61.5				
65	64.4	65.6	63.5	66.5				
70	69.4	70.0	68.5	71.5				
80	79.4	80.6	78.5	81.5				
90	89.3	90.7	88.25	91.75		907		
(95)	94.3	95.7	93.25	96.75	578			
100	99.3	100.7	98.25	101.75	600			
110	109.3	110.7	108.25	111.75				
120	119.3	120.7	118.25	121.75				1620
130	129.2	130.8	128	132				
140	139.2	140.8	138	142				
150	149.2	150.8	148	152			1611	
160	159.2	160.8	158	162				
180	179.2	180.8	178	182			1438	
200	199.02	200.92	197.7	202.3				
220	219.02	220.92	217.7	222.3				
240	239.02	240.92	237.7	242.3				2400
260	258.95	261.05	257.4	262.6				
280	278.95	281.05	277.4	282.6				
300	298.95	301.05	297.4	302.6				

NOTE:

1. Sizes in brackets are non-preferred
2. Preferred lengths are in between the stepped bold lines
3. Weights are given in Kg per 1000 numbers only.



PLANT STANDARD

HPBP TIRUCHIRAPPALLI

BPS 41221

Rev. No. 02

PAGE 1 OF 3

HEXAGON HEAD BOLTS, PRODUCT GRADE 'C' (Property Class 4.6)

1.0 SCOPE

Covers the requirements of Hexagon Head Bolts in the size range M36x3 and above.

2.0 SPECIFICATION AND REFERENCE STANDARDS

Dimensions and preferred sizes	Table 1 of this standard	
preferred length size combination	Table 2 of this standard	
Tolerance	Product Grade C	
	Indian Standard	IS 1367 (Part 2)
Thread	Pitch	Table 1 of this standard
	Tolerance	8g
	Indian Standard	IS 4218 (Part 3, 5 & 6)
Material	Steel	
Mechanical properties	Property class	4.6
	Indian Standard	IS 1367 (Part 3)
Sampling & Acceptability	Indian Standard	IS 1367 (Part 17)
General requirements	Hexagon Head bolts shall comply with IS 1363 (Part 1) in respect of requirements not covered in this standard.	

2.1 Referred Standards (Only the relevant parts of current versions are applicable)

IS 1363(Part 1)

Specification for hexagon head bolts, screws and nuts of product grade C. Part 1 Hexagon Head bolts.

IS 1367 (Parts 2,3)

Technical supply conditions for threaded steel fasteners.

IS 1367 Part 17

Industrial fasteners - Threaded steel fasteners-Technical supply conditions:Part 17 - Inspection, sampling and acceptance procedure.

IS 4218

ISO Metric screw threads

3.0 DESIGNATION

A Grade C, Hexagon Head Bolt to this standard of thread size M36x3 and nominal length 180 mm shall be designated as:

Revisions 02 Brought upto date			Approved STANDARDS SECTION PRODUCT ENGINEERING / FOSSILE BOILER HPBP, TIRUCHIRAPPALLI		
Rev. No. 02	Amd. No.	Reaffirmed	Prepared	Issued	Dt of 1st Issue
Dt. 31-07-2000	Dt.	Year	STANDARDS	STANDARDS	DEC 1986

COPYRIGHT AND CONFIDENTIAL
The information on this document is the property of BHARAT HEAVY ELECTRICALS LIMITED. It must not be used directly or indirectly in any way detrimental to the interest of the company.

3.1 On Drawings:

- i) Description column : **BOLT HEX Gr C 4.6- M36x3 x 180**
- ii) Drawing Number column : **BPS 41221**
- iii) Material Code column : **4122136180**

3.2 Ordering Description

For placing indents, issuing enquiries and on purchase order, ordering description given below shall be followed (typical examples).

Hexagon head bolt M36X3 x 180 - BPS: 41221-4.6

4.0 ADDITIONAL INFORMATION

- 4.1 Copies of this standard shall be enclosed along with the purchase order for thread sizes M36x3 and above.

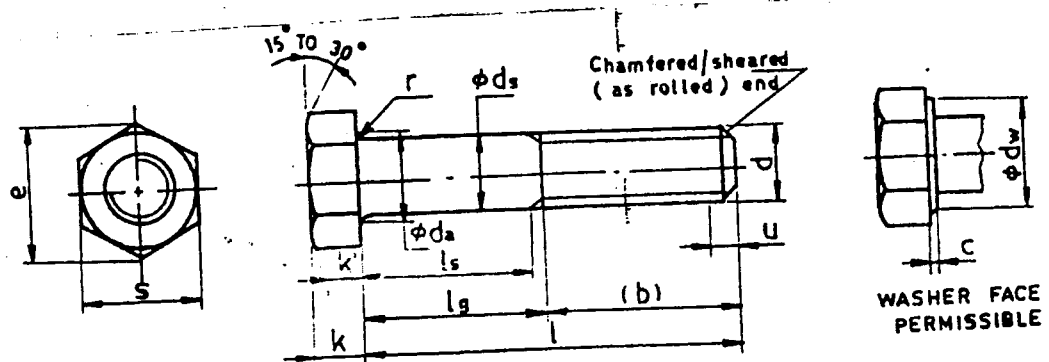

k' = Effective gauging height.

Table - 1
DIMENSIONS FOR HEXAGON BOLT
(All dimensions are in millimetres)

Thread size d	Pitch P	b * ** ***	c Max	da Max	ds Max Min	dw Min	e Min	k		r Min	s Max Min
								Min	Max		
M 36x3	3	78	0.8	42.4	37	51.1	60.79	21.45	15.0	1.0	55
		84			35			23.55			53.8
		97									
(M39x3)	3	84		45.4	40		66.44	23.95		1.0	60
		90			38			26.05			58.8
		103									

NOTE:

1. "u" according to "CE" of IS :1368- Dimensions of ends of bolts and screws.
2. * For nominal lengths 'l' ≤ 125 mm
- ** For nominal lengths 'l' > 125 and ≤ 200 mm
- *** For nominal lengths 'l' > 200 mm
3. l_g Max (grip length) = l Nom - b
- l_s Min (shank length) = l_g Max - 5 x Pitch



PLANT STANDARD

HPBP TIRUCHIRAPPALLI

BPS 41221

Rev. No. 02

PAGE 3 OF 3

TABLE 2
PREFERRED LENGTH- SIZE COMBINATION
FOR HEXAGON HEAD BOLTS
(All dimensions are in mm)

Thread size d M36x3 (M39x3)

Nom. Length 'l'

Nom	Min	Max
110	108.25	111.75
120	118.25	121.75
130	128	132
140	138	142
150	148	152
160	156	164
(170)	166	174
180	176	184
(190)	186	194
200	195.4	204.6
220	215.4	224.6
240	235.4	244.6
260	254.8	265.2
280	274.8	285.2
300	294.8	305.2

Note:

1. Size in brackets are non-preferred.
2. Preferred lengths are in between the stepped bolt lines.
3. Weights are given in Kg per 1000 numbers only.



PLANT STANDARD

HPBP TIRUCHIRAPPALLI

BPS 41301

Rev. No. 02

PAGE 1 OF 2

HEXAGON NUTS, PRODUCT GRADE 'B'

(Property Class 6 & 22H)

1.0 SCOPE

Covers the requirements of hexagon nuts in the size range M27, M33 and above.

2.0 SPECIFICATION AND REFERENCE STANDARDS

Dimensions and preferred sizes	Fig. 1 & Table 1 of this standard	
Tolerance	Product grade	B
	Indian Standard	IS 1367 (Part 2)
Thread	Pitch	Table 1 of this standard
	Tolerance	6H
	Indian Standard	IS 4218 (Part 3, 5 & 6)
Material	Steel	
Mechanical Properties	Property class	
	6 H for nuts with $d \leq M39 \times 3$	
	22H for nuts with $d > M39 \times 3$	
	Indian Standard	
	IS: 1367 (Part 6) for nuts with $d \leq M39 \times 3$	
	IS: 1367 (Part 7) for nuts with $d > M39 \times 3$	
Sampling and Acceptability	Indian Standard	IS: 1367 Part 17)
General requirements	Nuts shall comply with IS: 1364 (Part 3) in respect of requirements not covered in this standard.	

2.1 Referred standards (Only current versions are applicable)

IS 1364 Part 3	Specification for Hexagon head bolts & nuts of product grade A&B Part 3 Hexagon nuts.
IS 1367 Part 2,6,7 & 17	Technical supply conditions for threaded steel fasteners
IS 4218 Part 3,5 & 6	ISO metric screw threads
IS 3138	Hexagonal bolts and nuts

3.0 DESIGNATION

A Grade 'B' hexagon nut to this standard of thread size M36x3 shall be designated as :

3.1 On Drawings

i) Material Specification column	-----
ii) Description Column	HEX NUT M36x3-6
iii) Drawing Number Column	BPS 41301
iv) Material Code column:	4130100036

COPYRIGHT AND CONFIDENTIAL

The information on this document is the property of BHARAT HEAVY ELECTRICALS LIMITED. It must not be used directly or indirectly in any way detrimental to the interest of the company.

Revisions			Approved		
Brought upto date			STANDARDS SECTION CONTRACT ENGINEERING AND CO-ORDINATION HPBP, TIRUCHIRAPPALLI		
Rev. No. 02	Amd. No.	Reaffirmed	Prepared	Issued	Dt of 1st Issue
Dt. JUN. 1997	Dt.	Year	STANDARDS	STANDARDS	DEC 1986



PLANT STANDARD

HPBP TIRUCHIRAPPALLI

BPS 41301

Rev. No. 02

PAGE 2 OF 2

3.2 Ordering Description

For placing indents, issuing enquiries and on purchase order, Ordering Description given below shall be followed. (Typical examples)

- Hex Nut M27 to BPS : 41301 (for nuts with d=M27 & M33)
- Hex Nut M36x3 to BPS : 41301 (for nuts with d=M36x3 & M39x3)
- Hex Nut M42x3 to BPS : 41301 (for nuts with d=M42x3 & M48x3)

4.0 ADDITIONAL INFORMATION

- 4.1 The hardness values in Table 4 of IS: 1367 Part 6 (for coarse pitch series) shall be applicable for thread sizes M36x3 and M39x3 also.
- 4.2 The overall dimensions for thread sizes M42x3 and above are based on IS: 3138.
- 4.3 Copies of this standard shall be enclosed along with the purchase order.

FIG.1. DIMENSIONS FOR HEXAGON NUTS
(All dimensions are in millimetres)

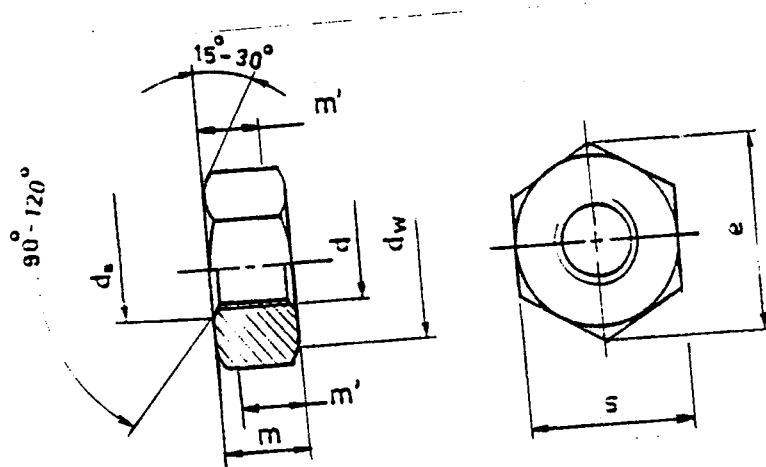

'm' = Effective gauging height

TABLE 1
(All dimensions are in millimetres)

Thread Size d	da		dw	e		m		m'	s		Weight
	Min	Max		Max	Min	Max	Min		Max	Min	
(M27)					45.20	22.0	20.7		41	40.0	166
(M33)					55.37	26.0	24.74		50	49.0	299
M36x3	36	38.9	51.1		60.79	31.0	29.4	23.52	55	53.8	364
(M39x3)					66.44	31.0	29.4		60	58.8	485
M42x3				75		34.0	33.0		65	63.8	569
M48x3				86.5		38.0	37.0		75	73.8	935

Note:

- 1. Sizes in brackets are non-preferred
- 2. Weights are given in Kg per 1000 numbers only



PLANT STANDARD

HPBP TIRUCHIRAPPALLI

BPS 41304

Rev. No. 02

PAGE 1 OF 2

HEXAGON NUTS, PRODUCTS GRADES 'B' & 'C'

(Property Class 4 & 14H)

1.0 SCOPE

Covers the requirements of hexagon nuts in the size range M27, M33 and above

2.0 SPECIFICATION AND REFERENCE STANDARDS

Dimensions and preferred sizes	Fig 1 & Table 1 of this standard	
Tolerance	Product grade	C for nuts with $d \leq M64$ B for nuts with $d > M64$
	Indian Standard	IS 1367 (Part 2) for nuts with $d \leq M39 \times 3$ IS: 3138 for nuts with $d \geq m42 \times 3$
Thread	Pitch	Table 1 of this standard*
	Tolerance	7H for nuts with $d \leq M39 \times 3$ 6H for nuts with $d \geq M42 \times 3$
	Indian Standard	IS 4218 (Part 3, 5 & 6)
Material	Steel	
Mechanical properties	Property class	4 for nuts with $d \leq M39 \times 3$ 14H for nuts with $d \geq M42 \times 3$
	Indian standard	IS: 1367 (Part 6&7)
Sampling and Acceptability	Indian Standard	IS: 1367 (Part 17)
General requirements	Nuts shall comply with IS: 1363 part 3 and IS: 3138 in respect of requirements not covered in this standard	

2.1 Referred standards (only current versions are applicable)

IS: 1367 (Part 2, 6, 7 & 17)

IS: 3138

IS: 4218 (Part 3, 5 & 6)

Technical supply conditions for threaded steel fasteners

Specification for hexagon bolts and nuts

ISO Metric screw threads

3.0 DESIGNATION

A Grade 'C' hexagon nut to this standard of thread size M36x3 shall be designated as :

3.1 On Drawings

- Material Specification column
- Description Column
- Drawing Number Column
- Material Code column:

HEX NUT GR C M36x3-4

BPS 41304

4130400036

Revisions

Brought upto date •

Approved

STANDARDS SECTION
CONTRACT ENGINEERING AND CO-ORDINATION
HPBP, TIRUCHIRAPPALLI

Rev. No. 02

Amd. No.

Reaffirmed

Prepared

Issued

Dt of 1st Issue

Dt. JUN 1997

Dt.

Year

STANDARDS

STANDARDS

DEC 1986



PLANT STANDARD

HPBP TIRUCHIRAPPALLI

BPS 41304

Rev. No 02

PAGE 2 OF 2

3.2 Ordering Description

For placing indents, issuing enquires and on purchase order, ordering description given below shall be followed. (Typical examples)

- i) HEXAGON NUT M33 TO BPS:41304 for nuts with $d=M27$ & M33
- II) HEXAGON NUT M36x3 TO BPS:41304 for nuts with $d \geq M36X3$

4.0 ADDITIONAL INFORMATION

Copies of this standard shall be enclosed alongwith the purchase order for thread sizes M27, M33 and above.

FIG. 1 DIMENSIONS FOR HEXAGON NUTS
(All dimensions are in millimetres)

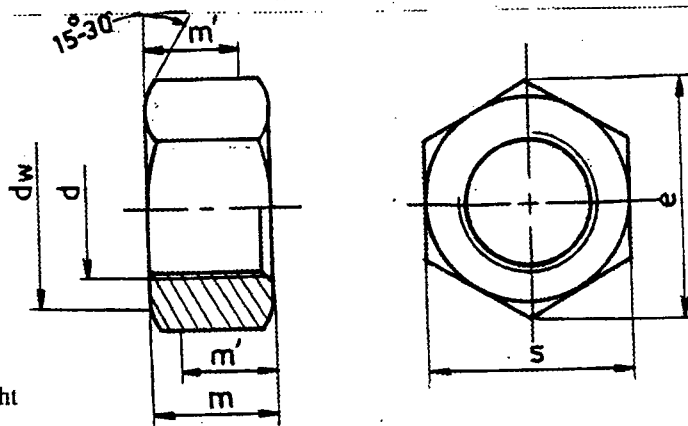

'm' = Effective gauging height

TABLE 1
(All dimensions are in millimetres)

Thread Size d	d _w Min	m		m' Min	s		e		Weight
		Max	Min		Max	Min	Min	Max	
(M27)		22.65	21.35		41	40.0	45.20		166
(M33)		26.65	25.35		50	49.0	55.37		299
M36x3	51.1	31.5	29.4	23.5	55	53.8	60.79		364
(M39x3)		31.8	30.2		60	58.8	66.44		485
(M45x3)		36.0	35.0		70	68.8		80.8	750
M48x3		38.0	37.0		75	73.8		86.5	935
M56x4		45.0	44.0		85	83.6		98	1355
(M60x4)		48.0	47.0		90	88.6		104	1625
M72x4		58.0	56.8		105	103.6		121	2430
M80x4		64.0	62.8		115	113.6		133	3190

NOTE:

1. Sizes in brackets are non-preferred.
2. Weights are given in Kg per 1000 numbers only.



PLANT STANDARD

HPBP TIRUCHIRAPPALLI

BPS 41319

Rev. No. 03

PAGE 1 OF 2

NUTS FOR TEMPERATURE USE

(For medium of temperature upto 425 ° C)

1.0 SCOPE

Covers the requirements of hexagon nuts for use in medium of temperature upto 425 ° C and in the size range M8 to M45x3.

2.0 SPECIFICATION AND REFERENCE STANDARDS

Dimensions and preferred sizes	Fig 1 & Table 1 of this standard	
Tolerance	Product grade	A for nuts with $d \leq M16$ B for nuts with $d > M16$
	Indian Standard	IS 1367 (Part 2)
Thread	Pitch	Table 1 of this standards
	Tolerance	6H
	Indian Standard	IS 4218 (Part 3, 5 & 6)
Material	Steel to ASTM A 194 2H Certified	
Testing	The finished nut shall satisfy the requirements of hardness, proof load and cone proof load, tests as specified in ASTM A194	
General requirements	Nuts shall comply with TDC:5:166 in respect of requirements not covered in this standard, except for cadmium plating	

2.1 Referred standards (Only the relevant parts of current versions are applicable)

IS 1367 (Part 2)	Technical supply conditions for threaded steel fasteners
IS 4218 (Part,3,5 & 6)	ISO metric screw threads
TDC:5:166	Carbon steel nuts for OFE & other applications as per A 194 GR 2H/2HM
ASTM A194	Specification for carbon and alloy steel nuts for bolts for high pressure and high temperature service.

3.0 DESIGNATION

A Grade 'A' hexagon nut to this standard of thread size M8 shall be designated as :

3.1 On Drawings

i) Material Specification column	ASTM A 194 - 2H
ii) Description Column	NUT HEX GR A T425 M8
iii) Drawing Number Column	BPS 41319
iv) Material Code column:	4131900008

COPYRIGHT AND CONFIDENTIAL

The information on this document is the property of BHARAT HEAVY ELECTRICALS LIMITED. It must not be used directly or indirectly in any way detrimental to the interest of the company.

Revisions Brought upto date			Approved STANDARDS SECTION CONTRACT ENGINEERING AND CO-ORDINATION HPBP, TIRUCHIRAPPALLI		
Rev. No. 03	Amd. No.	Reaffirmed	Prepared	Issued	Dt of 1st Issue
Dt. JUN 1997	Dt.	Year	STANDARDS	STANDARDS	DEC 1986



PLANT STANDARD

HPBP TIRUCHIRAPPALLI

BPS 41319

Rev. No. 03

PAGE 2 OF 2

3.2 Ordering Description

For placing indents, issuing enquiries and on purchase order, Ordering Description given below shall be followed. (Typical examples)

Hex Nut M8 to BPS : 41319-A-ASTM A194-2H for nuts with $d \leq M16$

Hex Nut M20 to BPS : 41319-B-ASTM A194-2H for nuts with $d > M16$ and $d < M36 \times 3$

Hex Nut M36x3 to BPS: 41319-B-ASTM A194-2H for nuts with $d \geq M36 \times 3$

4.0 ADDITIONAL INFORMATION

4.1 Copies of this standard and TDC:5:166 shall be enclosed along with the purchase order.

Figure 1 DIMENSIONS FOR HEXAGON NUTS

(All dimensions are in millimetres)

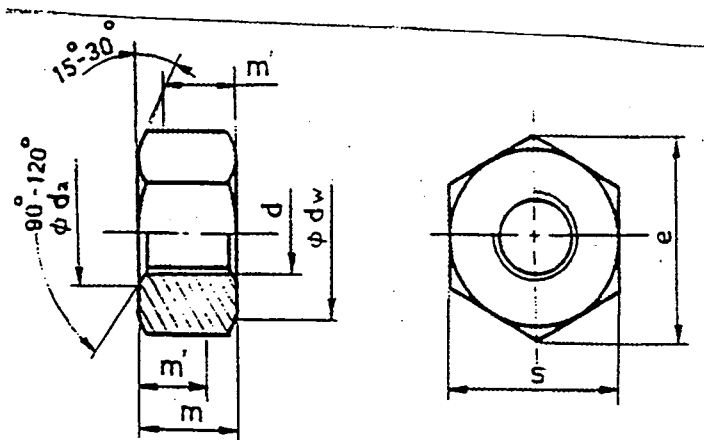

'm' = Effective gauging height

TABLE I

(All dimensions are in millimetres)

Thread Size d	d _a		d _w	e		m		m'	s		Weight
	Min	Max		Max	Min	Max	Min		Max	Min	
M8	8	8.75	11.6		14.38	8	7.64	6.1	13	12.73	6.0
M10	10	10.80	14.6		17.77	10	9.64	7.7	16	15.73	10.8
M12	12	13.00	16.6		20.03	12	11.57	9.3	18	17.73	16.5
M16	16	17.30	22.5		26.76	17.1	16.40	13.1	24	23.67	33.0
M20	20	21.60	27.7		32.95	20.7	19.40	15.5	30	29.16	64.5
M24	24	25.90	33.2		39.55	24.2	22.90	18.3	36	35.00	110.0
(M27)					45.20	27.6	26.30	21.0	41	40.00	166.0
M30	30	32.40	42.7		50.85	30.7	29.10	23.3	46	45.00	231.0
(M33)					55.37	33	31.40	25.1	50	49.00	299.0
M36x3	36	38.90	51.1		60.79	36.6	35.00	28.6	55	53.80	364.0
(M39x3)					66.44	39	37.40	29.9	60	58.80	485.0
(M45x3)				80.8		45	43.40	34.7	70	68.80	750.0

NOTE :

- Sizes in brackets are non-preferred.
- Weights are given in Kg per 1000 numbers only.



PLANT STANDARD

HPBP TIRUCHIRAPPALLI

BPS 41324

Rev. No. 04

PAGE 1 OF 2

NUTS FOR HIGH TEMPERATURE USE

(For medium of temperature from 525°C to 565°C)

1.0 SCOPE

Covers the requirements of hexagon nuts for use in medium of temperature from 525°C to 565°C and in the size M10 to M95x4.

2.0 SPECIFICATION AND REFERENCE STANDARDS

Dimensions and preferred sizes	Fig 1 & Table 1 of this standard	
Tolerance	Product grade	A for nuts with $d \leq M16$ B for nuts with $d > M16$
	Indian Standard	IS: 1367 :Part 2
Thread	Pitch	Table 1 of this standard
	Tolerance	6H
	Indian Standard	IS 4218: Part 3
Material	Steel to ASTM A194 Gr 7 certified in quenched and tempered condition	
General requirements	Nuts shall comply with TDS:5:166 in respect of requirements not covered in this standard except for cadmium plating.	

2.1 Referred standards (Only current versions are applicable)

IS 1367: Part 2 Technical supply conditions for threaded steel fasteners

IS 4218: Part 3 ISO metric screw threads

ASTM A194 Specification for carbon and alloy steel nuts for bolts for high pressure and high temperature service

TDC:5:166 Carbon & Alloy Steel Nuts to Specification SA 194 Gr2H/2HM/Gr4/Gr7 for Valves, Oil Field Equipment & other applications.

3.0 DESIGNATION

A Grade 'A' hexagon nut to this standard of thread size M10 shall be designated as:

3.1 On Drawings

- i) Material Specification column ASTM A 194 Gr 7
- ii) Description Column HEX NUT GR A T525 - 565 M10
- iii) Drawing Number Column BPS 41324
- iv) Material Code column: 4132400010

Revision 04
Size M64x6 Added

Approved

STANDARDS SECTION
I.T. SOLUTIONS & SERVICES
HPBP, TIRUCHIRAPPALLI

Rev. No. : 04

Amd. No.

Reaffirmed

Prepared

Issued

Dt of 1st Issue

Dt. 07-08- 2015

Dt.

Year

STANDARDS

STANDARDS

FEB 1990



PLANT STANDARD

HPBP TIRUCHIRAPPALLI

BPS 41324

Rev. No. 04

PAGE 2 OF 2

3.2 Ordering Description

For placing indents, issuing enquiries and on purchase order, Ordering Description given below shall be followed. (Typical examples)

Hex Nut M10 to BPS : 41324-A-ASTM A 194 Gr 7 for sizes upto M16

Hex Nut M30 to BPS : 41324-B-ASTM A 194 Gr 7 for sizes M20 to M30

Hex Nut M36x3 to BPS : 41324-C- ASTM A 194 Gr 7 for sizes M36x3 and above

4.0 ADDITIONAL INFORMATION

4.1 Copies of this standard and TDC: 5:166 shall be enclosed along with the purchase order.

FIG 1 DIMENSIONS FOR HEXAGON NUTS (All dimensions are in millimeters)

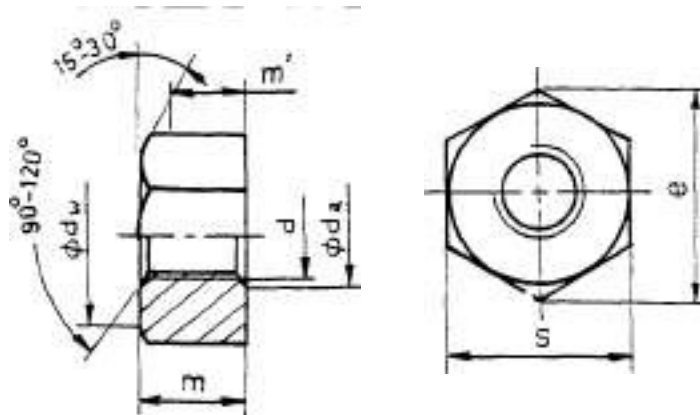

'm' = Effective gauging height

TABLE 1 (All dimensions are in millimeters)

Thread size d	d _a		d _w Min	e		m		M' Min	s		Weight
	Min	Max		Max	Min	Max	Min		Max	Min	
M10	10	10.8	14.6		17.77	10	9.64	7.7	16	15.73	10.8
M12	12	13.0	16.6		20.03	12	11.57	9.3	18	17.73	16.5
M16	16	17.3	22.5		26.75	17.1	16.40	13.1	24	23.67	33.0
M20	20	21.6	27.7		32.95	20.7	19.40	15.5	30	29.16	64.5
M24	24	25.9	33.2		39.55	24.2	22.90	18.3	36	35.0	110.0
(M27)					45.20	27.6	26.30	21.0	41	40.0	166.0
M30	30	32.4	42.7		50.85	30.7	29.10	23.3	46	45.0	231.0
M36x3	36	38.9	51.1		60.79	36.6	35.00	28.6	55	53.8	364.0
(M48x3)				86.5		48	46.40	37.1	75	73.8	935.0
M60x4	60	64.8		104		48	47		90	88.6	1625
M72x4	72	77.8		121		72	71		105	103.6	3020
M95x4	95	102.6		190		95	94		164.5	163	12200
M36x4	36	38.9	51.3	60.8	61.02	36	34.40	27.5	55	54	430
M42x4.5	42	45.4	60.8	75.1	72.32	42	40.40	32.3	65	64	810
M48x5	48	51.8	70.3	86.5	83.62	48	46.40	37.1	75	74	1240
M56x4	56	60.5	79.6	98	94.69	56	54.10	43.3	85	83.8	1760
M64x4	64	69.1	88.5	110	105.2	54	52.10	41.7	95	93.1	2460
(M64x6)	64	69.1	88.5	110	105.2	54	52.10	41.7	95	93.3	2460

NOTE:

1. Sizes in brackets are non-preferred
2. Weights are given in Kg per 1000 numbers only



PLANT STANDARD

HPBP TIRUCHIRAPPALLI

BPS 41408

Rev. No. 02

PAGE 1 OF 2

PUNCHED WASHERS - TYPE A

1.0 SCOPE

Covers the requirements for punched washers Type A in the size range 61 to 78 mm.

2.0 SPECIFICATION AND REFERENCE STANDARDS

DIMENSIONS & TOLERANCES	<i>Dimensions and tolerances</i>	Figure 1 and Table 1 of this standard	
MATERIAL	<i>Material</i>	Suitable steel	
FINISH	<i>Finish</i>	Natural finish	
SAMPLING & ACCEPTABILITY	<i>Sampling and acceptability</i>	Indian Standard	IS 6821 and IS 5369
GENERAL REQUIREMENTS	<i>General Requirements</i>	Washers shall comply with IS 2016 in respect of requirements not covered in this standard.	

2.1 Referred Standards (Only current versions are applicable)

IS 2016	Specification for plain washers.
IS 5369	General requirements for plain washers and lock washers.
IS 6821	Methods for sampling non-threaded fasteners.

3.0 DESIGNATION

A punched washer of size 61 to this standard for bolt/screw size M56 shall be designated as :

3.1 On Drawings

i) Material Specification column	:
ii) Description column	:	PUNCHED WASHER A 61
iii) Drawing Number column	:	BPS 41408
iv) Material Code column	:	4140800056

3.2 Ordering Description

For placing indents, issuing enquiries and on purchase order, ordering description given below shall be followed (typical examples).

Punched Washer A61 to BPS 41408

Revisions 02
Brought upto date .

Approved
STANDARDS SECTION
CONTRACT ENGINEERING AND CO-ORDINATION
HPBP, TIRUCHIRAPPALLI

Rev. No. 02	Amd. No.	Reaffirmed	Prepared	Issued	Dt of 1st Issue
Dt. JUNE 1997	Dt.	Year	STANDARDS	STANDARDS	DEC 1986

4.0 ADDITIONAL INFORMATION

- 4.1 These washers can be used with Product Grade C general purpose bolts and screws.
- 4.2 Copies of this standard shall be enclosed alongwith the purchase order.

Figure - 1

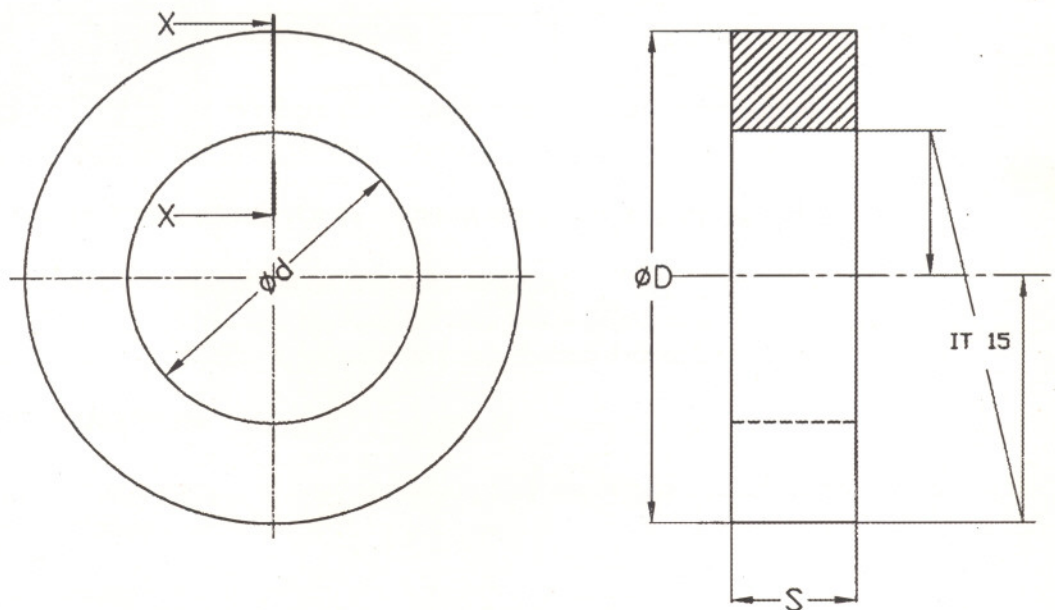

SECTION XX

Table - 1

(All dimensions are in millimetres)

Size ϕd	ϕD Nom	s Nom	For bolt/screw size	Weight
61	105	9.0	M56	405.0
78	122	10.0	M72	543.0

NOTE:

- 1. Weights are given in Kg per 1000 numbers.



Product: CARBON & ALLOY STEEL FASTENERS (STUDS, BOLTS & NUTS) FOR VALVES, OIL FIELD EQUIPMENT (OFE) AND OTHER APPLICATIONS

Revision Record: 00: 17.01.90: First issue. Rev: 01:21.06.90 Editorial corrections. Rev 02:21.04.91 TC for studs/bolts added. Rev 03: 04.04.96: Annexure I amended. CI 3.3.3 & 5.3 modified. Rev 04:20.10.96: NDT, Acid pickling added & re-written. Rev 05: 28.04.98: CI 3 modified to include MPI, certificate modified & CI 7.4 deleted. Rev 06:15.06.99: Title, CI 1 to 5 & 7.1 modified. CI 7.2 changed to CI 7.3. CI 7.3 changed to 7.4 and modified. CI 7.2 Galvanizing added. Test certificate sample format modified.

Rev 07: 15/06/2017: TDC: 5:166 for CS & AS Nuts has been merged with this TDC. Totally revised in line with changed requirements and Xylan coating requirements added.

Rev 08: 14/09/2019: CI 1.0, 2.0, 3.0, 4.0, 5.0 modified in line with API 6A 21st Ed 2018 Errata 1 and for better clarity.

1.0 MATERIAL SPECIFICATIONS:

All the codes, standards, specifications, drawings & procedures, etc., referred in this TDC shall be of latest revision as on the date of Purchase Order, unless specified otherwise.

Studs/Bolts - Alloy Steel	:	ASME/ASTM SA/A 193 Gr B7, B7M & B16.
Nuts - Carbon Steel	:	ASME/ASTM SA/A 194 Gr 2H & 2HM
Alloy Steel	:	ASME/ASTM SA/A 194 Gr 4 & 7
Additional Requirements	:	As listed below (Supplementary to the above material specifications)
Size and Quantity	:	As per Purchase Order (PO) & Applicable Drawing

2.0 GENERAL REQUIREMENTS:

- i. This TDC is applicable for Valves, OFE (API 6A 21st Ed 2018 Errata 1 & 16C 2nd Ed 2015 Addendum 1 Errata 4) and other applications including NACE MR0175 / ISO 15156:2015 Parts 1, 2 & 3. The products shall be manufactured to the relevant requirements specified in the applicable drawings, specifications, PO & this TDC.
- ii. *Studs / Bolts / Nuts used for OFE application:*
 - a. *Studs / Bolts / Nuts shall be qualified and manufactured in accordance with BSL 1 of API 20E. The qualification & requalification records as per API 20E shall be maintained by the Supplier. The supplier shall prepare and Manufacturing Process Specification(MPS) to include as a minimum allowable levels for all Studs/Bolts/Nuts manufacturing parameters including process control variables and heat treatment parameters as per API 20E and this TDC.*
 - b. *Raw material shall be fully wrought. Reduction ratio based on starting material diameter shall be a minimum of 4:1. The steel shall conform to the respective material specifications. Intentional addition of Boron is not allowed. All elements intentionally added to the heat shall be reported in the Test Certificate.*
 - c. *Furnace calibration shall be in accordance with API 6A Annex M; SAE AMS 2750; or SAE AMS H6875. For induction or direct resistant heat treatment, calibration shall be in accordance with manufacturer's written procedure. For forging furnaces, calibration shall be in accordance with manufacturer's written procedure*
- iii. Nuts shall be hot/cold forged or manufactured from hot rolled/cold drawn bars. If made from hexagonal bars, 100% MT is to be done on bars as per ASTM E709 to ensure freedom from surface/sub-surface defects.
- iv. Hot rolled & cold drawn bars, if used (for studs/bolts or nuts), shall be machined at least 2 mm (minimum) in radius (i.e. 4 mm in diameter) to remove the seams completely. After machining, at least 10% of the bars shall be tested by MPI as per ASTM E709 to ensure freedom from surface/sub-surface defects.
- v. Heat treatment of finished studs/bolts shall be carried as per the material specification requirements for corresponding grades. For heat treatment of finished components, salt bath



Product: CARBON & ALLOY STEEL FASTENERS (STUDS, BOLTS & NUTS) FOR VALVES, OIL FIELD EQUIPMENT (OFE) AND OTHER APPLICATIONS

or controlled atmosphere furnace shall be used. After heat treatment, the threads shall be thoroughly cleaned to remove all deposits. If acid pickling is done for cleaning, it shall be as per Cl. 6 (v) of this TDC.

- vi. Cadmium Plating (Cl 6 (i) of this TDC), Electroplating (Cl 6 (ii) of this TDC) and/or Xylan Coating (Cl 6 (iii) of this TDC) shall be done on the fasteners if specified in Drawing/PO. For all other cases, rust preventive coating (Cl 6 (iv) of this TDC) shall be done.

3.0 CHEMICAL, MECHANICAL PROPERTIES & NDE:

- i. Mill certificate from steel manufacturer for conformance to chemistry heat-wise shall be submitted. Additionally, product analysis shall be done on one sample/heat by the stud/bolt/nut manufacturer. *Methods and practices for chemical analysis shall be in accordance with ASTM A 751.*
- ii. *The microstructure and macrostructure shall conform to the requirements of the respective material specifications.*
- iii. **Tensile Testing for Studs/Bolts:** One tensile test/heat/size/ HT batch shall be carried out in the finished heat treated condition as per SA / A 193 and shall meet the material specification requirements for corresponding grades.
- iv. **Hardness Testing for Studs/Bolts:**

Hardness testing, including specimen preparation, shall be performed in accordance with ASTM A 370 including Annex A3, except that testing shall also be in conformance with ASTM E10 or ASTM E18.

- a) **For SA / A 193 Gr B7 & B16:** Hardness check shall be carried out on finished stud/ bolt as per SA / A 193, at least on 10% of the finished studs/bolts.
*Gr B7: Hardness: 25 to 34 HRC or 253 to 319 HBW.
Gr B16: Hardness: 25 to 35 HRC or 253 to 321 HBW.*

- b) **For SA / A 193 Gr B7M:**
Hardness check on 100% of studs/bolts as per SA193.
Gr B7M: Hardness: 94 to 99 HRB or 201 to 235 HBW.

v. **Mechanical Testing for Nuts:**

- a) **For SA / A 194 Gr 2H, Gr 4, & Gr 7:**
Hardness check on finished nuts shall be as per SA / A 194 (including quantum of testing).
*Gr 4: Hardness: 24 to 35 HRC or 248 to 327 HBW.
Gr 2H & Gr 7: Hardness: 24 to 34 HRC or 248 to 319 HBW.*
- b) **For SA / A 194 Gr 2HM:**
Hardness check on 100% of finished nuts shall be carried out as per SA / A 194.
Gr 2HM: Hardness: 159 to 235 HBW.
- c) **Proof load test shall be done as per SA / A 194 for all grades of nuts** and shall meet the requirements of corresponding grades of the material specification.
- d) After final heat treatment, sample nuts shall be heat treated as per Table 1 and meet the corresponding hardness requirements.

Table 1.

Grade	Temperature (°C)	Soaking Time (Hr)	Cooling	Minimum Hardness (HBW) at room temperature
2H	540	24	Slow Cool	179
2HM	540	24	Slow Cool	159
4, 7	590	24	Slow Cool	201



Product: CARBON & ALLOY STEEL FASTENERS (STUDS, BOLTS & NUTS) FOR VALVES, OIL FIELD EQUIPMENT (OFE) AND OTHER APPLICATIONS

e) **Cone Stripping Test:** This test shall be performed as per SA / A 194 in case of visible surface discontinuities. On such cases Proof load shall be as per SA / A 194.

vi. **NDE:**

Magnetic particle inspection shall be carried out as per ASTM E709 in at least 10% of the finished studs/bolts of all grades. Cracks, linear indications (length \geq 3 times its width) are unacceptable.

4.0 SAMPLING INSPECTION:

All inspection shall be in accordance with relevant drawing or BPS (Boiler Plant Standard), PO, this TDC and SA / A 193 for studs/bolts and SA / A 194 for nuts. The threads shall be checked with calibrated ring gauges for studs/bolts & plug gauges for nuts in the final heat treated condition for black variety and in final plated/coated condition for the cadmium plated/electroplated/ xylan coated items.

Visual, dimensional checks and their acceptance shall be as per applicable drawing and ASME SA / A 193 for studs/bolts & SA / A 194 for nuts.

5.0 MARKING & PACKING:

- i. Punch/emboss each finished component with applicable material grade (B7/ B7M/ B16 for studs/bolts; 2H/2HM/4/7 for nuts) and supplier's emblem. Studs/bolts of grade B7M and nuts of Gr 2HM shall have a line under the grade symbol.
- ii. Punch/emboss serial number also in B7M studs/bolts and Gr 2HM nuts in addition to the above, to correlate with hardness. Protect the threaded ends with plastic end caps. Pack in wooden box/ gunny bag of convenient size for easy handling and transportation. Mark quantity in each box/gunny bag.
- iii. *In addition to the above, studs / Bolts / Nuts for OFE applications shall marked with unique heat lot identification and followed by "20E1". Each piece 1 in. nominal diameter and larger shall be marked. For studs / Bolts / Nuts less than 1 in. nominal diameter, the studs / Bolts / Nuts shall be securely containerized to maintain heat lot identification and traceability. Multiple heat lots shall not be mixed in a single container. Containers used in the processing, storing, and shipping of studs / Bolts / Nuts not individually marked shall be clearly labeled with all marking information required by the relevant material specifications and API 20E.*

6.0 SPECIAL REQUIREMENTS:

i. CADMIUM PLATING:

- a) Clean the fasteners to make them free from rust, grease, oil, scale, etc., before plating. When pickling is considered essential, it shall be done as per CI 6 (v) of this TDC.
- b) Apply Cadmium Plating to the specified thickness on specified areas. Thickness shall be measured on 5% of the PO quantity of fasteners.
- c) After plating, bake the parts at 175°C to 205°C for a minimum period of 3 hours. The elapsed time between plating and baking shall not exceed 8 hours.
- d) Apply a Chromate Conversion coating after plating and baking.

ii. ELECTROPLATING OF ZINC CHROMATE:

- a) Clean the fasteners to make them free from rust, grease, oil, scale, etc., by suitable organic solvents/ hand tool methods before electroplating. Then, pickling shall be done as per CI 6 (v) of this TDC.
- b) The fasteners shall then be electroplated as per the method and to the minimum coating thickness specified in the applicable drawing. Thickness shall be measured on 5% of the PO quantity of fasteners.

iii. XYLAN COATING:

- a) Clean the fasteners by blast cleaning to Sa2.5 to make them free from rust, grease, oil, scales, etc., before xylan coating.
- b) The fasteners shall then be xylan coated as per the requirements and to the minimum coating thickness specified in the applicable drawing.

	BHEL – Tiruchirappalli - 620014, India. Quality Assurance Department TECHNICAL DELIVERY CONDITIONS	DOC No: TDC:5:164 Rev: 08 Effective Date: 14/09/2019 Page: 4 of 6
	Product: CARBON & ALLOY STEEL FASTENERS (STUDS, BOLTS & NUTS) FOR VALVES, OIL FIELD EQUIPMENT (OFE) AND OTHER APPLICATIONS	

c) Tests for Xylan Coating:

The following test shall be carried out on Xylan coated fasteners and results to be reported in the Test certificate (in addition to the Test Certificate for the fastener material and other inspections requirements):

i) Thickness measurement:

Dry film thickness of Xylan coating to be measured using a magnetic induction or Eddy current type electronic gauge and the reading shall meet the drawing/PO requirement for thickness of coating of Xylan 1070. The thickness measurements shall be made in accordance with ASTM D7091. Thickness shall be measured on 5% of the PO quantity of fasteners.

ii) Cure Test:

This test method is for ensuring the completeness of cure of Xylan 1070 coating by evaluating the resistance of the cured coating to a solvent known to attack uncured film. The testing method shall be as per Whitford test method 115B (as recommended by the Xylan coating supplier).

Acceptance criteria: No white precipitate or stain shall be available after the test.

iii) Adhesion Test using Cross-hatch and Cello Tape:

Test as per ASTM D-3359 Method B for measuring Adhesion by Tape Test.

Acceptance Criteria: No loss of adhesion (5B Classification).

iv) Salt Spray Test:

Xylan coated fasteners should pass a minimum requirement of 500 hours of salt spray test as per ASTM B117. Certificate of compliance for meeting the salt spray test requirements shall be provided.

iv. RUST PREVENTIVE FLUIDS/COATING REQUIREMENTS:

a) Clean the fasteners to make them free from rust, grease, oil, scale, etc., by hand tool/ manual cleaning method.

b) Apply one coat of rust preventive fluid, of any of the following brands of the suppliers (Table 2), to obtain dry film thickness of 20 microns minimum:

Table 2. Rust Preventive Fluid/Coatings Brands

SI No	Brand/Chemical	Supplier Name and Address
1	BONITA-RPF	M/s Bonita Chemicals, 64, Industrial Estate, Nunhai, Agra-282 006
2	CHAMPION-RPF	M/s Guardian Chemicals, 8, Rajaji Hind st, West Lake Area, Nungambakkam, Madras-600 034
3	ECONOL RPF (non-drying type)	M/s Process Aids, Bangalore
4	TECTYL 506	M/s Plastipeel Chemicals and Plastics (P) Ltd, Thane-400 604
5	TRPF	M/s Sundaram Paints Pvt. Ltd., Thanjavur-613 004
6	TRPF	M/s Solar Paints, Pudukkottai.
7	WICOR-P	M/s Western India Paint and Color Co P. Ltd, Madras-600 017

Use of any other brand/chemical shall be done with the prior approval of BHEL.

v. ACID PICKLING:

a) Wherever pickling done, it shall be done using Hydrochloric acid of 5-10% concentration for a period of 5 to 10 minutes at room temperature with suitable inhibitor.



b) After pickling thorough rinsing shall be carried out with water to remove acid residues & further DM water rinsing. After thorough rinsing with DM water, the rinsing shall not show any red color (free acidity) when tested with methyl orange indicator.

	BHEL – Tiruchirappalli - 620014, India. Quality Assurance Department TECHNICAL DELIVERY CONDITIONS	DOC No: TDC:5:164 Rev: 08 Effective Date: 14/09/2019 Page: 5 of 6
	Product: CARBON & ALLOY STEEL FASTENERS (STUDS, BOLTS & NUTS) FOR VALVES, OIL FIELD EQUIPMENT (OFE) AND OTHER APPLICATIONS	

7.0 CERTIFICATION:

The manufacturer shall provide Test Certificates (TC) duly countersigned by the Authorized Inspecting Authority nominated by BHEL in P.O. (if specified) along with raw material TC from Steel Maker. Manufacturer's TC shall contain the following details as per the sample format attached as Annexure-1 to this TDC:

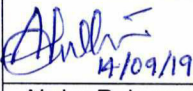
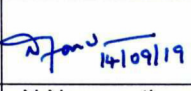
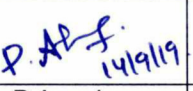
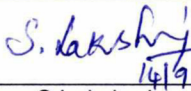
- i. BHEL PO No & PO Date
- ii. Technical Delivery Condition (TDC) No & its Revision No, Drawing & its revision no
- iii. Melt/Heat No, Serial No (if applicable)
- iv. Raw Material TC Number and Date
- v. Chemical and Mechanical properties for Studs/Bolts and Nuts
- vi. Heat treatment details (temperature, time, cooling medium, etc.)
- vii. NDE Results with reference and acceptance criteria
- viii. Type of Surface coating & its coating thickness – Cadmium Plating, Chromate conversion coating, Electroplating, Xylan Coating, Rust preventive coating, etc.
- ix. Test methods and results on Xylan Coating
- x. Baking details for cadmium plating, electroplating & Xylan coating
- xi. Manufacturers' identification mark
- xii. Certify soundness & confirmation to PO requirements.

 14/09/19	 14/09/19	 14/09/19	 14/09/19	 14/09/19	 14/09/2019
Abdur Rahman Sultan	N Nagamuthu Pandian	P Arun kumar	S Lakshmi	A Wilfred Joseph	J V V Aruna Kumar
SQAE/QA	DM/QA	SPE / Valves Engg	DGM/QA	AGM / Valves Purchase	SDGM / QA
Prepared By		Reviewed By		Approved By	



BHEL – Tiruchirappalli - 620014, India.
Quality Assurance Department
TECHNICAL DELIVERY CONDITIONS

DOC No: TDC:5:164 Rev: 08
Effective Date: 14/09/2019
Page: 6 of 6

Product: CARBON & ALLOY STEEL FASTENERS (STUDS, BOLTS & NUTS) FOR VALVES, OIL FIELD EQUIPMENT (OFE) AND OTHER APPLICATIONS

Annexure-1. Test certificate for Studs/Bolts & Nuts– Sample format

TC No:	Date:
Customer :	PO No./ Amd :
TDC No./Rev.:	DC No. :
Product :	Drg. No./Rev :
Description : (Spec, dia, pitch, length)	Thread Spec. :
Quantity :	

<u>Requirement</u> :	<u>Records/ Observation</u>
Size of bar - Before machining :	
- After machining :	
Type of furnace used for hardening :	

TDC Clause no.	Raw Material mill TC No:	TC Date:	
	Melt/Heat Number:		
2.0 & 3.0	a) Heat Treatment Details:		
	Hardening Temperature: °C; Soaking time:	Cooling Medium:	
	Tempering Temperature: °C; Soaking time:	Cooling Medium:	
	b) Additional Tempering for Nuts (after final tempering):		
	Temperature: °C; Soaking time:	Cooling Medium:	
3.0	a) Product analysis for chemistry		
	Report No & Date:		
	Spec	C Mn P S Si Cr Mo V Ni Others	
	Min.		
	Max.		
	Actual		
	b) Tensile test after H & T and final drying (Finished heat treated condition) – For Studs/Bolts		
		UTS (MPa)	YS (MPa) %Elongation %Red in Area
	Reqd/Spec Value		
	Test result		
	Spec Value	Test result Remarks	
	c) Hardness Test Result (for Studs/Bolts, Nuts):		
	d) Hardness Test Result (for Nuts after 24 hrs of tempering):		
	e) Proof load (kN) for nuts & result		
	f) Result of Cone Stripping test for nuts		
	g) NDE Result for Studs/Bolts:		
4.0	Visual and dimensional checking as per applicable drawing and ASME SA193 for studs/bolts & SA194 for nuts:		
5.0	Punching details (identification): End cap for threaded portion:		
6.0	a) Type of coating: Cadmium Plating /Chromate Conversion / Electroplating/ Xylan /Rust preventive coating (Tick applicable coating)		
	Coating thickness/DFT:		
	b) Tests for Xylan Coating	Results	
	c) Pickling Acid: Concentration:		
	Drying after pickling. Temperature: °C; Soaking time:		
This is to certify that the above results are correct and the parts meet specification and PO requirements.			
Signature with date Supplier: In-charge of Quality		Signature with date BHEL / Authorized Inspection Agency	

Note: Additional Sheets may be attached, if required.