



Bharat Heavy Electricals Limited

(A Govt. of India Undertaking)

Piping Centre, 80, G. N. Chetty Road, CHENNAI – 600 017

Phone : 91 (044) 28161965, e-mail: poongkodi@bhel.in

REF: GEM/2021/B/1750399

DT: 16.12.2021

Sub: Request For Quotation (RFQ) for supply of Welded Pipes conforming to IS3589- Reg.

Ref: Bid Number GEM/2021/B/1750399 dt 14.12.2021

BHEL/Piping Centre invites RFQ's for supply of Welded Pipes conforming to IS3589. The offers should be submitted in the Government e-procurement portal (<https://gem.gov.in/>). The offer will be opened at **14.30 hrs** on the **due date 24.12.2021**.

Please find the bid document and the general terms and conditions for the GeM enquiry. Relevant drawings, PQR criteria and Technical delivery conditions are enclosed herewith.

This is only a request for quotation and not an order.

Interested bidders may take a note of the same and provide your quotation in GeM.

Ms. Poongkodi.V
Deputy Manager / Purchase
BHEL, Piping Centre
80, G.N.Road, T.Nagar, Chennai –600 017
Phone – 9488451450. Email: poongkodi@bhel.in

For any clarifications on the Enquiry you may also contact

Mr. Venkataraman E, DGM / Purchase, Phone – 044-28161325, Email: vram@bhel.in

Ms. Priya Balaji, SDGM / Purchase, Phone – 044-28161244, Email: pb@bhel.in

Bid Document

Bid Details	
Bid End Date/Time	24-12-2021 14:00:00
Bid Opening Date/Time	24-12-2021 14:30:00
Bid Life Cycle (From Publish Date)	90 (Days)
Bid Offer Validity (From End Date)	80 (Days)
Ministry/State Name	Ministry Of Heavy Industries And Public Enterprises
Department Name	Department Of Heavy Industry
Organisation Name	Bharat Heavy Electricals Limited (bhel)
Office Name	10410005-pc Chennai
Total Quantity	6480
Item Category	159385490000 - PIPE DIA 219.1 X 6.0 IS3589-410MPA (Q3) , 159385380000 - PIPE DIA 273.1 X 6.0 IS3589-410MPA (Q3) , 159385390000 - PIPE DIA 323.9X6.4 IS3589FE410 MPA (Q3) , 159385260000 - PIPE DIA 406.4 X 6.0 EFW IS3589 LS/SPIRAL (Q3)
Minimum Average Annual Turnover of the Bidder	93 Lakh (s)
Years of Past Experience required	3 Year (s)
MSE Exemption for Years of Experience and Turnover	No
Startup Exemption for Years of Experience and Turnover	No
Document required from seller	Experience Criteria,Bidder Turnover,Certificate (Requested in ATC),Additional Doc 1 (Requested in ATC),Compliance of BoQ specification and supporting document *In case any bidder is seeking exemption from Experience / Turnover Criteria, the supporting documents to prove his eligibility for exemption must be uploaded for evaluation by the buyer
Bid to RA enabled	Yes
RA Qualification Rule	H1-Highest Priced Bid Elimination
Primary product category	159385260000 - PIPE DIA 406.4 X 6.0 EFW IS3589 LS/SPIRAL
Time allowed for Technical Clarifications during technical evaluation	2 Days
Evaluation Method	Item wise evaluation

EMD Detail

--	--

Required	No
----------	----

ePBG Detail

Required	No
----------	----

(a). The EMD % will be applicable for each schedule/group selected during Bid creation.

Splitting

Bid splitting not applied.

MII Purchase Preference

MII Purchase Preference	Yes
-------------------------	-----

MSE Purchase Preference

MSE Purchase Preference	Yes
-------------------------	-----

1. The minimum average annual financial turnover of the bidder during the last three years, ending on 31st March of the previous financial year, should be as indicated above in the bid document. Documentary evidence in the form of certified Audited Balance Sheets of relevant periods or a certificate from the Chartered Accountant / Cost Accountant indicating the turnover details for the relevant period shall be uploaded with the bid. In case the date of constitution / incorporation of the bidder is less than 3-year-old, the average turnover in respect of the completed financial years after the date of constitution shall be taken into account for this criteria.
2. Experience Criteria: In respect of the filter applied for experience criteria, the Bidder or its OEM {themselves or through reseller(s)} should have regularly, manufactured and supplied same or similar Category Products to any Central / State Govt Organization / PSU / Public Listed Company for number of Financial years as indicated above in the bid document before the bid opening date. Copies of relevant contracts to be submitted along with bid in support of having supplied some quantity during each of the Financial year. In case of bunch bids, the category of primary product having highest value should meet this criterion.
3. Preference to Make In India products (For bids < 200 Crore):Preference shall be given to Class 1 local supplier as defined in public procurement (Preference to Make in India), Order 2017 as amended from time to time and its subsequent Orders/Notifications issued by concerned Nodal Ministry for specific Goods/Products. The minimum local content to qualify as a Class 1 local supplier is denoted in the bid document. If the bidder wants to avail the Purchase preference, the bidder must upload a certificate from the OEM regarding the percentage of the local content and the details of locations at which the local value addition is made along with their bid, failing which no purchase preference shall be granted. In case the bid value is more than Rs 10 Crore, the declaration relating to percentage of local content shall be certified by the statutory auditor or cost auditor, if the OEM is a company and by a practicing cost accountant or a chartered accountant for OEMs other than companies as per the Public Procurement (preference to Make-in -India) order 2017 dated 04.06.2020. Only Class-I and Class-II Local suppliers as per MII order dated 4.6.2020 will be eligible to bid. Non - Local suppliers as per MII order dated 04.06.2020 are not eligible to participate. However, eligible micro and small enterprises will be allowed to participate .In case Buyer has selected Purchase preference to Micro and Small Enterprises clause in the bid, the same will get precedence over this clause.
4. Purchase preference to Micro and Small Enterprises (MSEs): Purchase preference will be given to MSEs as defined in Public Procurement Policy for Micro and Small Enterprises (MSEs) Order, 2012 dated 23.03.2012 issued by Ministry of Micro, Small and Medium Enterprises and its subsequent Orders/Notifications issued by concerned Ministry. If the bidder wants to avail the Purchase preference, the bidder must be the manufacturer of the offered product in case of bid for supply of goods. Traders are excluded from the purview of Public Procurement Policy for Micro and Small Enterprises. In respect of bid for Services, the bidder must be the Service provider of the offered

Service. Relevant documentary evidence in this regard shall be uploaded along with the bid in respect of the offered product or service. If L-1 is not an MSE and MSE Seller (s) has/have quoted price within L-1+ 15% (Selected by Buyer) of margin of purchase preference /price band defined in relevant policy, such Seller shall be given opportunity to match L-1 price and contract will be awarded for 25%(selected by Buyer) percentage of total QUANTITY.

5. Estimated Bid Value indicated above is being declared solely for the purpose of guidance on EMD amount and for determining the Eligibility Criteria related to Turn Over, Past Performance and Project / Past Experience etc. This has no relevance or bearing on the price to be quoted by the bidders and is also not going to have any impact on bid participation. Also this is not going to be used as a criteria in determining reasonableness of quoted prices which would be determined by the buyer based on its own assessment of reasonableness and based on competitive prices received in Bid / RA process.

6. Reverse Auction would be conducted amongst all the technically qualified bidders except the Highest quoting bidder. The technically qualified Highest Quoting bidder will not be allowed to participate in RA. However, H-1 will also be allowed to participate in RA in following cases:

- i. If number of technically qualified bidders are only 2 or 3.
- ii. If Buyer has chosen to split the bid amongst N sellers, and H1 bid is coming within N.
- iii. In case Primary product of only one OEM is left in contention for participation in RA on elimination of H-1.
- iv. If L-1 is non-MSE and H-1 is eligible MSE and H-1 price is coming within price band of 15% of Non-MSE L-1
- v. If L-1 is non-MII and H-1 is eligible MII and H-1 price is coming within price band of 20% of Non-MII L-1

Evaluation Method (Item Wise Evaluation Method)

Contract will be awarded schedulewise and the determination of L1 will be done separately for each schedule. The details of item-consignee combination covered under each schedule are as under:

Evaluation Schedules	Estimated Value	Item/Category	Quantity
Schedule 1	4667000	159385490000 - Pipe Dia 219.1 X 6.0 Is3589-410mpa	1300
Schedule 2	1591800	159385380000 - Pipe Dia 273.1 X 6.0 Is3589-410mpa	350
Schedule 3	9625400	159385390000 - Pipe Dia 323.9x6.4 Is3589fe410 Mpa	1700
Schedule 4	21017950	159385260000 - Pipe Dia 406.4 X 6.0 Efw Is3589 Ls/spiral	3130

159385490000 - PIPE DIA 219.1 X 6.0 IS3589-410MPA (1300 meter)

(Minimum 50% Local content required for MII compliance)

Brand Type	Unbranded
------------	-----------

Technical Specifications

Buyer Specification Document	Download
------------------------------	--------------------------

Consignees/Reporting Officer and Quantity

S.No.	Consignee/Reporting Officer	Address	Quantity	Delivery Days
1	Kavila Mohan Prabhakar	508115,The Assistant Divisional Engineer (Stores), Construction Division Yadadri TPS (5x800MW), Damaracherla (Mandal), Veeralapalem (Village), District - Nalgonda, Telangana - 508115.	1300	90

159385380000 - PIPE DIA 273.1 X 6.0 IS3589-410MPA (350 meter)

(Minimum 50% Local content required for MII compliance)

Brand Type	Unbranded
------------	-----------

Technical Specifications

Buyer Specification Document	Download
------------------------------	--------------------------

Consignees/Reporting Officer and Quantity

S.No.	Consignee/Reporting Officer	Address	Quantity	Delivery Days
1	Kavila Mohan Prabhakar	508115,The Assistant Divisional Engineer (Stores), Construction Division Yadadri TPS (5x800MW), Damaracherla (Mandal), Veeralapalem (Village), District - Nalgonda, Telangana - 508115.	350	90

159385390000 - PIPE DIA 323.9X6.4 IS3589FE410 MPA (1700 meter)

(Minimum 50% Local content required for MII compliance)

Brand Type	Unbranded
------------	-----------

Technical Specifications

Buyer Specification Document	Download
------------------------------	--------------------------

Consignees/Reporting Officer and Quantity

S.No.	Consignee/Reporting Officer	Address	Quantity	Delivery Days
1	Kavila Mohan Prabhakar	508115,The Assistant Divisional Engineer (Stores), Construction Division Yadadri TPS (5x800MW), Damaracherla (Mandal), Veeralapalem (Village), District - Nalgonda, Telangana - 508115.	1700	90

159385260000 - PIPE DIA 406.4 X 6.0 EFW IS3589 LS/SPIRAL (3130 meter)

(Minimum 50% Local content required for MII compliance)

Brand Type	Unbranded
------------	-----------

Technical Specifications

Buyer Specification Document	Download
------------------------------	--------------------------

Consignees/Reporting Officer and Quantity

S.No.	Consignee/Reporting Officer	Address	Quantity	Delivery Days
1	Kavila Mohan Prabhakar	508115,The Assistant Divisional Engineer (Stores), Construction Division Yadadri TPS (5x800MW), Damaracherla (Mandal), Veeralapalem (Village), District - Nalgonda, Telangana - 508115.	3130	90

Buyer added Bid Specific Additional Scope of Work

S.No.	Document Title	Description	Applicable i.r.o. Items
1	PQR Criteria View	Duly signed PQR sheet along with supporting documents to be furnished	159385490000 - PIPE DIA 219.1 X 6.0 IS3589-410MPA(1300),159385380000 - PIPE DIA 273.1 X 6.0 IS3589-410MPA(350),159385390000 - PIPE DIA 323.9X6.4 IS3589FE410 MPA(1700),159385260000 - PIPE DIA 406.4 X 6.0 EFW IS3589 LS/SPIRAL(3130)

S.No.	Document Title	Description	Applicable i.r.o. Items
2	Integrity Pact View	Integrity pact with signature of Authorized signatory, Witness and Full address of the firm	159385490000 - PIPE DIA 219.1 X 6.0 IS3589-410MPA(1300),159385380000 - PIPE DIA 273.1 X 6.0 IS3589-410MPA(350),159385390000 - PIPE DIA 323.9X6.4 IS3589FE410 MPA(1700),159385260000 - PIPE DIA 406.4 X 6.0 EFW IS3589 LS/SPIRAL(3130)
3	Testing and Inspection procedure for packing View	CI 3.2 shall be followed. Material for the Metallic end cap shall be minimum 0.8mm thick of specification IS1079.	159385490000 - PIPE DIA 219.1 X 6.0 IS3589-410MPA(1300),159385380000 - PIPE DIA 273.1 X 6.0 IS3589-410MPA(350),159385390000 - PIPE DIA 323.9X6.4 IS3589FE410 MPA(1700),159385260000 - PIPE DIA 406.4 X 6.0 EFW IS3589 LS/SPIRAL(3130)

The uploaded document only contains Buyer specific Additional Scope of Work and / or Drawings for the bid items added with due approval of Buyer's competent authority. Buyer has certified that these additional scope and drawings are generalized and would not lead to any restrictive bidding.

Buyer Added Bid Specific Terms and Conditions

1. Scope of Supply

Scope of supply (Bid price to include all cost components) : Only supply of Goods

2. Generic

Bidder shall submit the following documents along with their bid for Vendor Code Creation:

- Copy of PAN Card.
- Copy of GSTIN.
- Copy of Cancelled Cheque.
- Copy of EFT Mandate duly certified by Bank.

3. Generic

OPTION CLAUSE: The Purchaser reserves the right to increase or decrease the quantity to be ordered up to 25 percent of bid quantity at the time of placement of contract. The purchaser also reserves the right to increase the ordered quantity by up to 25% of the contracted quantity during the currency of the contract at the contracted rates. Bidders are bound to accept the orders accordingly.

4. Generic

- The Seller shall not assign the Contract in whole or part without obtaining the prior written consent of buyer.
- The Seller shall not sub-contract the Contract in whole or part to any entity without obtaining the prior written consent of buyer.
- The Seller shall, notwithstanding the consent and assignment/sub-contract, remain jointly and severally liable and responsible to buyer together with the assignee/ sub-contractor, for and in respect of the due performance of the Contract and the Sellers obligations there under.

5. **Generic**

Bidders are advised to check applicable GST on their own before quoting. Buyer will not take any responsibility in this regards. GST reimbursement will be as per actuals or as per applicable rates (whichever is lower), subject to the maximum of quoted GST %.

6. **Generic**

While generating invoice in GeM portal, the seller must upload scanned copy of GST invoice and the screenshot of GST portal confirming payment of GST.

7. **Certificates**

Material Test Certificate Should Be Sent Along with The Supply. The Material Will Be Checked by Buyer's Lab & the Results of the Lab will be the Sole Criteria for Acceptance of the Item.

8. **Certificates**

Bidder's offer is liable to be rejected if they don't upload any of the certificates / documents sought in the Bid document, ATC and Corrigendum if any.

9. **Inspection**

Nominated Inspection Agency: On behalf of the Buyer organization, any one of the following Inspection Agency would be conducting inspection of stores before acceptance:

Pre-dispatch Inspection at Seller Premises (applicable only if pre-dispatch inspection clause has been selected in ATC): BUREAU VERITAS / TUV SUD

Post Receipt Inspection at consignee site before acceptance of stores: YADADRI PROJECT SITE

10. **Buyer Added Bid Specific ATC**

Buyer uploaded ATC document [Click here to view the file.](#)

Disclaimer

The additional terms and conditions have been incorporated by the Buyer after approval of the Competent Authority in Buyer Organization. Buyer organization is solely responsible for the impact of these clauses on the bidding process, its outcome and consequences thereof including any eccentricity / restriction arising in the bidding process due to these ATCs and due to modification of technical specification and / or terms and conditions governing the bid. Any clause incorporated by the Buyer such as demanding Tender Sample, incorporating any clause against the MSME policy and Preference to make in India Policy, mandating any Brand names or Foreign Certification, changing the default time period for Acceptance of material or payment timeline governed by OM of Department of Expenditure shall be null and void and would not be considered part of bid. Further any reference of conditions published on any external site or reference to external documents / clauses shall also be null and void. If any seller has any objection / grievance against these additional clauses or otherwise on any aspect of this bid, they can raise their representation against the same by using the Representation window provided in the bid details field in Seller dashboard after logging in as a seller within 4 days of bid publication on GeM. Buyer is duty bound to reply to all such representations and would not be allowed to open bids if he fails to reply to such representations.

[This Bid is also governed by the General Terms and Conditions](#)

In terms of GeM GTC clause 26 regarding Restrictions on procurement from a bidder of a country which shares a land border with India, any bidder from a country which shares a land border with India will be eligible to bid in this tender only if the bidder is registered with the Competent Authority. While participating in bid, Bidder has to undertake compliance of this and any false declaration and non-compliance of this would be a ground for immediate termination of the contract and further legal action in accordance with the laws.

---Thank You---

General terms and conditions on GeM 3.0 (Version 1.19)

1. Introduction

This document is an electronic record published by GeM under the provisions of the Information Technology Act, 2000 and the rules made there under (as applicable) and shall act as valid agreement between Seller / Service Provider and Buyer. Further the use of GeM Portal for Sale / Purchase of Goods / Services and the **resulting Contracts shall be governed by the following General Terms and Conditions (GTC) (unless otherwise superseded by Product / Service specific Special Terms and Conditions (STC), Product / Track / Domain Specific STC of Particular Service including its SLA (Service Level Agreement) and BID/Reverse Auction Specific Additional Terms and Conditions (ATC) as applicable).**

Government e-Marketplace (GeM) is the National Public Procurement Portal; an end-to-end online Marketplace for Central and State Government Ministries / Departments, Central & State Public Sector Undertakings (CPSUs & SPSUs), Autonomous institutions and Local bodies, for procurement of common use goods & services. The portal is owned and managed by GeM SPV which is a Section 8 (Non-Profit) Company registered under the Companies Act, 2013. GeM SPV operates, monitors and supervises all the business transactions on the portal through the Managed Service Provider as per defined roles and responsibilities.

2. General Terms and Definitions:

- a. **“APPLICABLE LAWS”** shall mean any statute, law, ordinance, notification, rule, regulation, judgment, order, decree, bye-law, approval, directive, guideline, policy or other governmental restriction as may be in effect.
- b. **“GOODS”** shall mean an Article / product or an intangible product like software, technology transfer, licenses, patents or other intellectual properties being offered for sale on the GeM portal by Seller(s) on GeM. The term ‘Goods’ shall also include works and services which are incidental or consequential to the supply of such goods, such as, transportation, insurance, installation, commissioning, training and guarantee / warrantee obligations as defined in the scope of supply given in the contract.
- c. **“SERVICES”** shall mean the services offered or provided by the Seller such as IT Professional Services, Manpower Services, Security Services, Transport Services, etc. listed as Services on GeM. The term ‘Service’ shall also include supply of goods / articles which are incidental or consequential to the provisioning of such Services as defined in the scope of supply given in the contract.

- d. **“SERVICE LEVEL AGREEMENT (SLA)”** shall mean the Contractual Commitment that prevails between the Buyer and the Service Provider with regard to type of service to be provided, deliverables, desired performance level, reliability and responsiveness, monitoring process and service level reporting, response and issue resolution time-frame, repercussions / penalties / remedies for service provider not meeting its commitment. The SLA of a particular contract may carry the matrix regarding the delivery of the goods and/or services and the corresponding penalties or remedies and liquidated damages as applicable.
- e. **“CATEGORY SPECIFICATION”** shall mean the framework of technical features, functional capabilities, technical properties, certifications of the items etc. in a particular category. The Specifications shall identify the key parameters defining the products with all necessary validations related to configuration, type of data, restrictions, range / allowed values, allowed units etc. Sellers as well as Buyers while offering / buying the Goods / services shall have to comply with the validation rules / restrictions provided for in the Category Specification. Buyers / Sellers can not add parameters and / or drop down values not provided for in category Specification. If any Buyer / Seller desire to add new parameter, value, validation etc. against any category specification, they have to raise request for the same to GeM for incorporation in Category Specification.
- f. **“BUYER”** is the Contract placing authority, which includes Central/State Government Ministries/Departments including its attached/subordinate offices, Central/State Public Sector Units (PSUs) and Autonomous Bodies acting through its authorized officer(s) for and on behalf of President of India/Governor of the State /PSU/Autonomous Bodies, as the case may be, for purchase of Goods/Services offered by Sellers on GeM.
- g. **“SELLER / SERVICE PROVIDER”** on GeM shall mean any legal entity such as firm(s) of Proprietorship / Partnership Firm / Limited Liability Partnership / Private Limited / Limited company / Society registered under Society’s Act / Statutory Bodies etc., registered on GeM to sell its Good(s) / Service(s) to the Buyers registered on GeM.

The “Seller on GeM” will be either OEM (Original Equipment Manufacturer*) or Seller having authorization to sell products manufactured by the OEM in open market.

* OEM is the owner of the Brand / Trademark of the product being offered or in case of un-registered brand’s products / products with own brand, the actual manufacturer of the final product. To be recognized as an OEM on GeM, seller has to get Vendor Assessment Report from designated agency (unless exempted as per GeM VA policy) as per due process of vendor assessment notified on GeM portal

(which would include production of documentary evidences and demonstration of manufacturing facilities and / or capabilities as required).

In case of Services related to Goods, Service Provider on GeM will be either OEM or Service Provider having authorization to Service products manufactured by that OEM in open market. In respect of other Services, Service Provider on GeM will be any legal entity offering its services.

By registering on GeM portal , Seller / Service Provider hereby agrees to be bound by these General Terms and Conditions for Sale / Purchase of Goods and / or Services (GTC); Product / Service Specific Special Terms and Conditions (STC) and Service Level Agreements (SLAs) for various Services; and Additional (Bid Specific) Terms and Conditions (ATC) as applicable.

For the purpose of this document and transactions on GeM, Seller as well as Service Provider will be referred to as "Seller"

- h. **"USER ID and PASSWORD"** All users including Buyers and Sellers (primary as well as secondary) will get User ID and Password created on GeM following due registration process defined on GeM. It is the responsibility of the user to keep their User ID and Password secure and confidential. Individual user shall be solely and completely responsible for all transactions taking place on GeM portal using his / her User Id and Password and GeM shall not be responsible in any manner.
- i. **"LICENSE"** shall mean by registering the Seller and by offering Product / Service details on GeM, the Seller grants GeM a non-exclusive, royalty-free, irrevocable, perpetual and fully sub-licensable right to use, reproduce, modify, adapt, publish, translate, distribute, and/or display the content/materials which has been submitted to GeM excluding Aadhaar No. In case of registration of Primary user and creation of secondary user(s) by the Buyer/Seller, their Aadhaar (UID) details collected by GeM are solely for user verification and to apply e-signing on the documents. The e-sign is at par with digital signatures as per Information Technology Act Amendment 2008 and it works based on details available in Aadhaar database of UIDAI and there is no interference / intrusion in their personal details.
- j. **"CONTRACT"** shall mean the purchase order created / issued by the Buyer on GeM for supply of Goods / Services in electronic form which includes scope of supply, delivery instructions and specifications etc. as ordered by Buyer against such Contract besides the subject GTC, STC/ATC as the case may be.

3. Role, Responsibilities and Obligations of Seller/ Buyer:

A. Role and Responsibilities of Sellers on GeM are as under:

- i. Only Director (s) / Partner (s) / Proprietor (as applicable) are authorized to become Primary User and register any legal entity on GeM as Seller.
- ii. Once Seller/Service Provider is registered and account is created on GeM, the Primary user of the Seller/Service Provider can create Secondary User Accounts within Seller/Service Provider Organization with different Roles and Responsibilities. However, the Primary User creating Secondary User accounts shall continue to be fully responsible and accountable for all actions / transactions done by Secondary Users on GeM Portal.
- iii. Since GeM is a trust based Portal, the complete accuracy and integrity of data submitted in respect of the Seller and also in respect of the Goods / Services offered on GeM will be the sole responsibility of the Seller/Service Provider. Seller will be liable for administrative action as per GeM terms and conditions in case of any discrepancy / infirmity in any data / information submitted on GeM.
- iv. The Primary / Secondary Users of Sellers, offering Goods/Services and/or participating in e-Bidding / Reverse Auction on GeM, must ensure that they have the requisite authorization to enter into contract with Buyer(s) in GeM for and on behalf of the Seller, failing which such Seller as well as the individual(s) shall be vicariously liable for its actions and also for any liability arising out of such actions.
- v. Seller can offer any number of products. However, it will be the sole responsibility of the seller to satisfy themselves regarding possessing the requisites for doing business for the offered product(s). The Sellers are solely responsible for ensuring that there is no violation of any Intellectual Property Rights in their offer for sell / providing service on GeM.
- vi. The Seller should not exercise any corrupt influence on any aspect of contract and commit to take all measures necessary to prevent corruption maintaining complete transparency, integrity and fairness in all activities related to GeM.
- vii. The seller would represent its business on the GeM portal and is mandated to comply with all the terms and conditions of the platform. Sellers would be solely and absolutely responsible for the information provided about their organization, business, products and services on the portal and would be required to produce proof of such information, if requested at any point in time by the Buyer and / or GeM.

- viii. GeM would not allow creation of any fresh data related to Seller identity on GeM portal. All details provided by the Seller at the time of registration would be counter checked / verified through other data bases of Government such as PAN, MCA 21, Udyam Registration etc. For Financial details, PAN / Income tax Database shall be primary validating database and will override any conflicting data in any other database. If the data / details entered by the seller while registering on GeM is not verified with validating databases, registration will not be allowed. Further, in case of any conflict in details after registration, Seller's registration would be automatically suspended. It is the Seller's responsibility to keep all their information on GeM updated with the latest change(s). Non-updating of details on GeM within 7 days of such occurrence would make Seller liable for administrative actions.
- ix. Eligibility of Sellers in terms of Turn Over / Past Performance / Profitability etc. and also their eligibility for availing various benefits / advantages in terms of various Govt. Policies / Guidelines / Acts / Laws etc. shall be determined solely on the basis of data fetched / validated or verified through external agency / owner of that set of database such as IncomeTax / PAN Data Base, MCA 21, Udyam Registration, GSTN, Certifying Agencies such as BIS, BEE etc. In case of any discrepancy in data available in these databases, Seller has to get the same updated in the corresponding validating database before updating the same on GeM. Till such time only the existing validated information shall be used to decide seller's eligibility on GeM. Any default in sellers updating their data on partner sites / validating databases and any fall out of the same impacting adversely any transaction on GeM, shall entirely and exclusively be Seller's responsibility. GeM shall not be responsible for any consequential impact on any GeM transaction due to data discrepancy and / or suspension of seller account due to data discrepancy. Seller will be solely responsible for the same.
- x. The Seller shall be solely responsible for the Goods / Services including, without limitation, the applicable guarantee / warranty, shelf-life, quantity, quality and the title and for giving the correct and accurate details of the offer their Goods and / or /Services indicating product specifications, quantity which can be supplied over the specified time period, etc. as per catalogue or catalogue based template prescribed in GeM. Seller would ensure that the Goods or /Services offered are latest, new and complete in all respects. Where Seller is selling any Goods which needs spare parts, Seller should ensure and make available such spare parts for a minimum

period of three years from the date of expiry of warrantee period (unless otherwise specified). The individual Sellers shall ensure that the products offered in e-Bidding and/or ordered shall remain available on GeM during the bid / contract validity period.

- xi. Sellers shall offer minimum discount of 10% on the Maximum Retail Price (MRP) mandatorily (unless otherwise specified for offering their products on GeM). Sellers are free to offer higher discounts. The Seller must offer its best possible lowest price on GeM and undertake that it would not sell or offer to sell the same product outside GeM in comparable quantity on similar terms and conditions at a price equal to or lower than Offer Price on GeM. In case any such infringement by Seller is noticed, the Seller shall be liable to be removed / debarred from the GeM.
- xii. By offering their product on GeM, the Seller agrees for sharing price details of the offered Goods / Service by GeM authorities with other Government agencies including Department of Excise & Customs, Income tax, GST etc.
- xiii. Listing of Goods / Services in irrelevant / inappropriate categories is strictly prohibited. If any such infringement made by Seller leads to placement of a contract by any Buyer for such inappropriately offered product(s)/service(s) by the Seller, such contract shall be treated as null and void. No claim whatsoever against such contract shall be admissible and entertained.
- xiv. The Seller(s) shall pass on all the benefits associated with any scheme / offer / freebies provided by the OEM on any product from time to time on an "as-is basis" to the Buyer. This obligation will also apply to OEM's directly supplying the goods. Holding back any such offer or accounting such freebies in quantity supplied shall make such consignments liable to be rejected by the consignee and shall also be considered as inappropriate and against the GeM policies for which GeM reserves all rights to take necessary action against such Seller/OEM as deemed fit.
- xv. By registering on GeM and by participating in any bid on GeM, Seller undertakes that presently it is not "Debarred from Bidding" on the grounds mentioned in Rule 151 of GFR 2017.

B. Role and Responsibilities of Buyer on GeM:

Buyer Registration on GeM is divided in two categories:

- a. **Primary User:** In GeM , the Primary User is as under:

- i. Any officer of Central / State Government / PSU / Autonomous Bodies / Local Bodies / Constitutional Bodies / Statutory Bodies at the level of Deputy Secretary of the Government of India or equivalent
- ii. Head of the Office at Sub Centre / Unit / Branch, can Register his / her organization / unit on GeM portal as Primary User.

Primary User shall be responsible for registering the organization on GeM, for creating User accounts for Secondary Users, assigning them roles and responsibilities on GeM and for supervision of all transactions performed by Secondary Users under him / her.

Primary User shall also be vicariously responsible for ensuring compliance of General Financial Rules and / or Rules Governing Public Procurement in respect of their organization, all GeM terms and conditions and other Procurement Policies / Guidelines notified by the government from time to time, by all the secondary users including timely payments and for dispute resolutions as per GeM terms and conditions.

Primary user cannot perform any Procurement related transactions on GeM portal.

- b. **Secondary Users:** Secondary Users are officials responsible for procurement transactions on GeM including Placement of Contracts, Receipt of Stores, and Payments to the Sellers etc. The access rights permissible to registered Secondary users would be decided by the Primary User of the Department. Secondary Users may be given the roles of Buyer / Consignee / Drawing and Disbursement Office (DDO) / Paying Authority etc. For transaction on GeM portal, Buyer is the official who is responsible for processing procurement transaction up to Order Placement stage. Consignee is the Secondary User in Buyer Organization responsible for certifying receipt and acceptance of the goods procured.

Buyer's responsibilities on GeM portal are as under:

- i. The Buyers are responsible to ensure that the procurement done by them are in compliance of General Financial Rules and / or Rules Governing Public Procurement in respect of their organization, all GeM terms and conditions and other procurement Policies / Guidelines notified by the government from time to time, including timely payments as per GeM terms and conditions.
- ii. The Buyers (in all capacities i.e. as Buyer, Consignee, DDO, Paying Authority etc) are responsible to ensure that the procurement done by them are in compliance with GeM Terms and Conditions / Guidelines

and all contract related transactions are completed within time lines prescribed in GeM Contract.

- iii. The Buyers must ensure that they have the requisite authorization to enter into contract with Seller(s) on GeM for and on behalf of the organization, failing which such individual(s) shall be individually liable for its actions and also for any liability arising out of such actions.
- iv. While making procurement on GeM, the Buyers shall judiciously search and shortlist items using filters such as quantity, technical parameters, delivery period, warranty period, consignee location(s), Seller's eligibility etc. as per their approved requirements. Placement of contract for a product / service uploaded by the Seller in any wrong/inappropriate product category is strictly prohibited and such contracts shall be treated as null and void and such Buying shall adversely affect Buyer Rating on GeM.
- v. The Buyers shall satisfy themselves that the price of the selected offer is reasonable. Buyer is at liberty to utilize all the data / information and Business Analytics made available in GeM including e-bidding and reverse auction.
- vi. The Buyers, before placing the order on GeM, should have the required mandatory approval with prior sanction and approval of the competent authorities and shall be in compliance with and as per procedures outlined in GFR and other procurement guidelines issued by the Government from time to time.
- vii. On award of the Contract(s), it would be construed that the Buyer has obtained all necessary Administrative & Financial sanctions of the competent authority and adequate funds are available indicating the relevant Head of accounts in the awarded Contract(s).
- viii. The Buyers should not exercise any corrupt influence on any aspect of contract and commit to take all measures necessary to prevent corruption maintaining complete transparency and fairness in all activities related to GeM.
- ix. Buyers are not allowed to place any order at GeM prices outside GeM. The prices on GeM are only applicable if the procurement is made through GeM portal. Using GeM prices for procurement outside GeM portal is strictly prohibited. Further, Buyers are not allowed to place any off-line contract to the Seller directly based on the outcome of e-Bidding

/ RA conducted on GeM. All such contracts shall be treated as null and void and GeM reserves the right to delete all data related to such transactions from GeM database besides taking suitable actions against such Buyers including suspension from GeM and / or reduction of Buyer rating etc.

4. Enabling provisions of Rule 149 of General Financial Rules- 2017

Enabling provisions of Rule 149 of General Financial Rules- 2017 as amended vide Ministry of Finance OM dated 02.04.2019 regarding procurement through GeM and necessary guidelines and terms and conditions thereon:

GeM portal may be utilized by the Government buyers for on-line purchases as under:-

- i. Up to Rs.25,000/- through any of the available suppliers on the GeM, meeting the requisite quality, specification and delivery period.
- ii. Above Rs.25,000/- and up to Rs.5,00,000/- through the GeM Seller having lowest price amongst the available sellers (excluding Automobiles where limit of Rs.30,00,000/- will be applicable), of at least three different manufacturers, on GeM, meeting the requisite quality, specification and delivery period. The tools for online bidding and online reverse auction available on GeM can be used by the Buyer if decided by the competent authority.
- iii. Above Rs.5,00,000/- through the supplier having lowest price meeting the requisite quality, specification and delivery period after mandatorily obtaining bids, using online bidding or reverse auction tool provided on GeM (excluding Automobiles where limit of Rs.30,00,000/- will be applicable).
- iv. The Government Buyers may ascertain the reasonableness of prices before placement of order using the Business Analytics (BA) tools available on GeM including the Last Purchase Price on GeM, Department's own Last Purchase Price etc.
- v. GFR rule 149 allows direct on-line purchases on GeM up to Rs. 25,000/- through any of the available suppliers on the GeM, meeting the requisite quality, specification and delivery period. However this is subject to procuring authorities certifying the reasonability of rates. While making such direct on-line purchase below Rs. 25,000/-, the buyer should have

approval of competent authority and should also record reasons for selecting the specific product in case lowest priced products are not being accepted / ordered.

- vi. Tools have been deployed on GeM portal to show the price of compared products on other e-commerce sites (wherever available) and also the rates at which orders have been placed on GeM for such items in recent past. While taking decision on reasonableness of price, the buyers may also take into account the discount over MRP; Last Purchase Price on GeM, Department's own Last Purchase Price; rates on other e-commerce websites etc. The prices on e-commerce site give a broad idea and its terms and conditions may be different. If it is found that the price available on GeM marketplace is not reasonable or is substantially higher than e-commerce sites or LPP, the GeM Portal provides tools for online bidding or reverse auction which can be used by the Buyers to get better competitive rates and then satisfy themselves about reasonableness of the price as per GFR -2017 before placement of contract. Bidding should be considered as the preferred mode of procurement above Rs. 25,000/-.
- vii. In case of Direct Purchase, during carting period, rates for carted quantity, for that buyer, are frozen for carting period as notified from time to time on GeM against any upward revision by seller. However, advantage of any downward revision in the offer price of carted item shall be automatically provided to the buyer.
- viii. According to the provisions of Rule 149 (ii) of GFR, 2017, GeM shall be utilized by Government buyers for direct on-line purchases above Rs. 25,000/- and up to Rs. 5,00,000/- however such purchase has to be through the Seller having the lowest price (L-1) amongst the available Sellers on the GeM. In order to ensure that buyers select only L-1 available offer, the GeM portal requires that buyer first compares all the product options available on GeM to ensure that it meets its requirements/ specifications. While comparing, care should be taken that comparison has to be done between products of at least three different Manufacturers / OEMs. For L-1 buying, comparison has to be made between products of at least three different OEMs. If Buyer wants to buy any specific OEM's product then he has to go for Proprietary Article Certificate (PAC) buying after obtaining necessary approvals of competent authorities for PAC buying as per GFR-2017.
- ix. **Proprietary Article Certificate (PAC) Buying:** While making procurement under PAC Buying on GeM, Buyer has to comply with following conditions:

(a) In case a Govt. Buyer on GeM wants to make procurement on proprietary basis on the GeM Portal after obtaining the requisite approvals / PAC certificate from their competent authority as per Rule 166 of GFR-2017, the Buyer can use PAC filter provided on GeM for selecting a specific model/ make available from a particular GeM Seller. As per GFR, Proprietary Article Certificate in the following form should be available with Buyer before procuring the goods under PAC Buying:

(i) The indented goods are manufactured by M/s.

(ii) No other make or model is acceptable for the following reasons:

(iii) Concurrence of Finance wing to the proposal vide:

(iv) Approval of the competent authority vide:

(b) The Seller's price on the Portal is just their offer prices and the proper discovery of price generally happens through bidding/RA. Moreover, in PAC procurement irrespective of multiple listing by authorised sellers, the important issue of price control remaining with the OEM cannot be overlooked. Therefore, in case of all the PAC procurements, the Buyers will have to carry out extra due diligence in establishing the reasonableness of prices before placement of contract as per Para (vii) of Rule -149 of GFR-2017.

(c) Except for direct buying up to Rs. 25,000/- subject to establishing the reasonableness of price, the bidding will be mandatory for procurements above Rs. 25,000/-. As result of bidding, the response could be as under:

i. Only OEM is available or only single authorised seller is available.

ii. OEM as well as multiple authorised Sellers are available.

iii. Multiple authorised Sellers of the OEM are available.

(d) After bidding, under PAC buying, the Buyer may take decision with the approval of the competent authority to process the

procurement subject to establishing the reasonableness of prices before placement of contract as per Para (vii) of Rule - 149 of GFR-2017.

- x. In order to give flexibility to the buyers in sourcing their requirements through GeM, provision has been made in e-bid and RA modules for indicating delivery period in terms of “number of days from date of placement of contract”. While stipulating delivery period in their bid documents, Buyers are advised to be careful since un-realistic delivery period stipulations may result in elimination of some genuine sellers, lack of competition and may ultimately have impact on cost of procurement. While fixing delivery period in e-bid/ RA bid, buyers should not only take into consideration the quantity required and the essentiality of requirement of that quantity within stipulated time period but also the possible impact of shorter delivery period on competition in e-bidding / RA.
- xi. Splitting of demands by creating multiple Bids / RAs of same goods / services or making repeated procurements of same Goods / Services through L-1 buying as per rule 149(i) and 149(ii) of GFR-2017 are strictly prohibited on GeM. Splitting of demand deprives the organizations from achieving the best competitive prices leveraging economies of scale. It also implies avoiding the necessity of obtaining the sanction of higher authority required with reference to the estimated value of the total demand. It is a violation of Para Rule 149 (viii) of GFR -2017 and terms and conditions of GeM Portal and Buyer including the Primary Buyer shall be entirely responsible for the same. If any such splitting of demand is noticed, GeM shall have the right to take necessary action such as blocking of such Bids/RAs and / or cancelling such contracts.
- xii. GeM is a dynamic online marketplace. The product/service listings across the existing categories are dynamic. Moreover, new categories of products/services are continuously being added on GeM. In situations where there is only one offer available in a product/ service category and/or there is offer from only one Seller after filter based search, the buyer should not select such offer for buying. Efforts should be made by Buyer to get their past suppliers and prospective Sellers on-boarded on GeM so as to ensure availability of sufficient Sellers on GeM. This however will not apply for PAC procurement.
- xiii. e-Bidding and Reverse Auction (RA) on GeM**

- (a) The e-Bidding / RA module of GeM is a tool provided to the Buyer(s) for organizing bidding / RA from GeM Sellers of the particular product category for a pre-defined requirement i.e. quantity, technical parameters for Goods/ Services of the particular product category required for one or more Buyers / Consignees.
- (b) Prior to initiating e-Bidding / RA, the Buyer shall judiciously search and shortlist item among the items offered on GeM using filters such as quantity, technical parameters, warranty period, consignee location(s) etc. as per the requirement. In case the search made using actual quantity required, fails to identify sufficient offers, the Buyer may use an indicative quantity for initial search and selection of product and quantity may be amended to match the actual requirement at the time of finalizing e-Bidding / RA.
- (c) The technical parameters and warranty of the item identified by the Buyer shall be base parameters of the item for conducting e-Bidding / RA for the required Goods/Services.
- (d) The e-Bidding / RA document will be finalized by the Buyer(s) by stipulating requirements such as Quantity, Consignee Details, Terms of Delivery, Delivery Period, EMD, Performance Bank Guarantee, Time & Date for Start and End of Bid Submission and for Opening of Bids and required Bid Validity period etc. GeM system shall decide Start / Reference Price and Step Value of Decrement in case of RA based on product selection and / or outcome of bidding process.
- (e) Bid Life Cycle: Bid Life Cycle is the period within which a buyer has to complete the entire life cycle i.e. technical evaluation, financial evaluation and order creation of Bid process. By default, it is 90 days from the date of Bid publication. This can be configured to 120 / 150 or 180 days in exceptional cases through catalogue Management System (CMS) for a particular product category (not for a particular Buyer or Bid).
- (f) The e-Bidding / RA invitation / Notice shall be published on GEM, stipulating the last date for bid submission / opening of bids giving at least clear 10 days time after the publication. Any change in last date for bid submission will be intimated to

eligible bidders through e-mail / GeM. The e-Bidding invitation shall be extended to all the registered Sellers on GeM who have Goods / Services for that particular category listed on GeM, at least 2 hours prior to closing time of e-Bidding / RA. The GeM normally requires 48 hrs for approval / rejection of the product / service offered by Sellers before it is listed on the portal. Considering these time lines, the Sellers are required to offer their Goods / Services on GeM well in advance before bid closure. The decision of the Buyer/GeM regarding technical/commercial eligibility of the individual Seller to be invited for e-Bidding / RA shall be final.

- (g) The Seller participating in the e-bidding / RA may offer any one of their product(s) already listed on GeM. The bid submitted under e-Bidding / RA shall remain valid for 15 days (or as stipulated by the Buyer in the bid document) from the Bid Opening Date (till 24.00 Hrs IST). Bid Validity can be further extended with mutual consent between Buyer and Seller subject to the condition that total Bid Life Cycle cannot go beyond the stipulated time limit as per GeM CMS. The products offered in e-Bidding / RA can not be withdrawn by the Sellers from GeM during the bid validity period. The Buyer reserves the right to postpone/cancel the e-bidding and intimation thereof will be sent by e-mail / GeM to the Bidders. Any amendment / corrigendum to the e-bid invitation issued by the Buyer will be made online and shall be uploaded on the GeM. The participation by the Seller in e-bidding shall be construed as his / her acceptance for all the Terms and Conditions as outlined in the e-bidding including GTC, STC and ATC. However, the Buyer shall have right to decide the technical and commercial acceptability of the individual bids based on eligibility criteria and compliances as stipulated in the bid document. The technical parameters shown in the bid are from a particular catalogue as selected by the buyer while applying initial filters in selection of the product. The sellers are free to bid for same, equivalent or superior specifications catalogue / products. In the public interest, buyers will evaluate such bids based on their requirements / end use and

bid parameters and will accordingly technically accept or reject the bids on merits.

- (h) In bid documents, Buyers can incorporate suitable eligibility criteria and additional terms and conditions only using various filters and ATC module available in e-bidding / RA modules of GeM. Buyers are not allowed to incorporate eligibility criteria and / or additional / special terms and conditions exterior to the GeM portal by making reference to any other website / documents etc.
- (i) In case, two or more acceptable bidders are found to have quoted identical lowest bid price, Buyer has to conduct Reverse Auction for the required Goods among all technically qualified bidders in case of bids for Goods. In case of Services bids, if the multiple L-1 bidders have quoted the lowest allowed price for that service, Buyer shall have two options for placement of Contract:
 - a) Placement of contract by selection of an agency from amongst the L-1 bidders through a Random Algorithm run by GeM system.
 - b) Placement of contract on any one of the L-1 bidders based on any criteria as deemed fit by the Buyer with appropriate internal approvals
- (j) The Buyer reserves the right to accept/reject any bid including the lowest bid received through e-bid and/or annul the e-bidding process.
- (k) The participating bidders shall not disclose details of their bids or other details of their e-bids to other bidders or indulge in any anti-competitive behaviour including price manipulation in violation of Competition Act, 2002.
- (l) The Buyer/GeM will not be held responsible for consequential damages such as no internet connection, no power supply, system problems, loss of electronic information, power interruption etc.
- (m) Against any bidding or RA conducted on GeM, if a bidder quotes Nil Charges/consideration, the bid shall be treated as non-responsive and will not be considered.

(n) There shall be no EMD for Bids / RA having estimated value less than Rs. 5 lakh. For bids / RA having estimated value more than Rs 5 Lakh, while finalizing e-Bid / RA, Buyer shall indicate the exact amount of EMD required to be submitted by bidders in the form of Bank Guarantee on GeM portal in the prescribed format. Scanned copy of the same shall be uploaded by Seller in the online bid and hard copy of the same will have to be submitted directly to the Buyer within 5 days of bid opening. GeM recommends quantum of EMD @ 1% of estimated value of procurement. The Buyer also has the option to select EMD between 0.5% to 5%. The same should be valid for 45 days beyond the bid validity. Following categories of Sellers shall however, be exempted from furnishing EMD:

- i. Micro and Small Enterprises who are manufacturer of the Primary Product Category or Service Provider of the Primary Service Category and give specific confirmation to this effect at the time of bid submission and whose credentials are validated online through Udyam Registration and through uploaded supporting documents.
- ii. Start-ups as recognized by Department of Industrial Policy and Promotion (DIPP).
- iii. KVIC, ACASH , WDO, Coir Board, TRIFED and Kendriya Bhandar.
- iv. Sellers who have got their credentials verified through the process of Vendor Assessment by Vendor Assessment Agencies for the Primary Product / Primary Service for which Bid / RA has been invited.
- v. Sellers/ Service Provider having annual turnover of Rs 500 Crore.
- vi. Micro and Small Enterprises registered with NSIC for the Primary Product Category whose credentials are validated through NSIC database and through uploaded supporting documents.
- vii. Micro and Small Enterprises registered with DIC for the Primary Product Category whose credentials are validated through DIC database and through uploaded supporting documents.

- viii. Sellers / Service Providers holding BIS License for the Primary Product Category whose credentials are validated through BIS database and through uploaded supporting documents.
 - ix. Central / State PSUs.
 - x. Seller / Service Provider registered with designated Agency / Authority as specified in the bid document by the Buyer – such bidder shall have to upload scanned copy of relevant registration document in place of EMD document while bidding.
- (o) EMD submitted by the bidder shall be forfeited, if the bidder:
- i. Withdraws or modify or impairs or derogates from the bid in any respect within the period of validity of its bid; or
 - ii. If it comes to notice that the information / documents furnished in its bid is false, misleading or forged; or
 - iii. Fails to furnish requisite performance security / PBG within stipulated time required as per e-bid / RA conditions.
- (p) Notwithstanding above, GeM SPV / GeM Admin also reserve the right to debar such seller from GeM portal. Such debarment shall be for minimum 3 months initially on first such offence and on repeat offence, the debarment period can be increased suitably by GeM SPV / GeM Admin. By submitting a bid on GeM, the Bidder explicitly undertakes to abide by the above clause.
- (q) Earnest money of unsuccessful bidders shall be returned within 15 days after the award of contract or expiry of bid validity whichever is earlier. Earnest money of successful bidder shall be returned within 15 days after receipt of Performance Security / e-PBG.
- (r) In case of RA, Start / Reference Price and Step Value of Decrement shall be indicated to the Bidders at the start of the auction. Any participating bidder can bid one or multiple Step Decrement lower than the prevailing Lowest Bid at that time.
- (s) The Bidder shall be able to view Bid Start Price, Bid Decrement Value, Prevailing Lowest Bid value and last Bid Placed by him. Whenever a lower price bid is received in the closing moment

i.e. within 15 minutes of existing end time of Reverse Auction, the end time of reverse auction shall be extended automatically by another 15 minutes. All participant sellers of that RA shall be notified by the GeM system about extension of time through email and/or SMS and they shall be allowed to submit revised bid under the RA. The same process shall be repeated, if there is another lower bid received in the RA during last 15 minutes of RA.

(t) GeM / Buyer shall not have any liability to bidders for any interruption or delay in access to the GeM site / Reverse Auction link etc, irrespective of the cause.

(u) By creating a bid on GeM, the Buyer undertakes as under:

"I confirm that this tender document complies with the "Public Procurement (Preference to Make in India) Order, 2017" issued by DIPP and "Public Procurement Policy for Micro and Small Enterprises (MSEs) Order, 2012" issued by MoSME".

(v) **Bid to RA:** While creating bid on GeM, Buyer shall have the provision to select Bid to RA option. If this option is selected by the Buyer at the time of bid creation, Sellers would be required to submit their Technical and Commercial bids before bid closure. After completion of technical evaluation by the Buyer, Reverse Auction would be conducted amongst first 50% of the technically qualified bidders arranged in the order of prices from lowest to highest. Number of sellers eligible for participating in RA would be rounded off to next higher integer value if number of technically qualified bidders is odd (e.g. if 7 bids are technically qualified, then RA will be conducted amongst L-1 to L-4). In case number of technically qualified bidders are 2, RA will be between both without any elimination.

In case Primary products of only one OEM are left in contention for participation in RA based on lowest 50% bidders qualifying for RA, the number of sellers qualifying for RA would be increased to get at least products of one more OEM (directly participated or through its reseller) if available. Further, if bid(s) of any seller(s) eligible for SME preference is / are coming within price band of 15% of L-1 or if bid of any seller(s)

eligible for Make in India preference is / are coming within price band of 20% of L-1, then such SME / Make in India seller shall also be allowed to participate in the RA process. After the RA process, the award of contract(s) shall be made by the buyer keeping in view the Public Procurement Policy for Micro and Small Enterprises (MSEs) Order, 2012 and Public Procurement (Preference to Make-in-India) Order, 2017 last revised on 29.5.2019 as amended from time to time.

- (w) In case any Seller / Service provider has been debarred in any particular Department / Organization, Buyers of that particular Department / Organization only shall have the right to disqualify such Sellers / Service providers at the time of technical evaluation of Bids during the period of debarment, subject to the condition that orders of such debarment has been taken with approval of Competent Authority of that Department / Organization and has been communicated to the concerned Seller / Service Provider before bid opening date.
- (x) GeM is an end to end on-line procurement portal and not a tender publishing portal. GeM has detailed GTC, product / service specific STC and a rich ATC library in-built in the portal which can be used to create a comprehensive bid document. Based on the available terms and conditions, there is hardly any need to add any additional conditions to be attached with any GeM bid. However, for inclusion of some clause which is considered absolutely necessary for that particular bid for reasons to be explained in detail, a provision for inclusion of additional conditions in the bid through corrigendum is available in Request Management System. Only indispensable conditions that are not covered in and are not in conflict with GeM GTC, Product / Service STC and the standard ATC library, and which are in compliance with the Govt. orders on Public Procurement and are not restrictive and not against the core principals of transparency, fairness and efficiency enshrined in GeM, can be requested through RMS ATC request for making part of GeM bid through corrigendum. Each such request has to be made only after due approval of the Competent Authority in Buyer Organization confirming that the request has been made with the approval of the Competent

Authority. Buyer organization shall be solely responsible for the impact of the requested clauses on the bidding process and its outcome. The clauses which are already covered in standard ATC library available on GeM Portal, will not be allowed through RMS.

- (y) **Determination of eligibility in case of products requiring BIS License:** In case the bid requires availability of BIS License, bidder has to upload currently valid and operative BIS License copy (Valid on the date of bid opening) to be considered eligible. Submitted BIS License may be in the name of Bidder / OEM or in the name of the Manufacturer to whom the OEM has outsourced manufacturing of his brand of product. The name of the Brand of the offered product should be mentioned in the BIS License. BIS certificate issued under Compulsory registration Scheme for electronic products to OEM/Brand owners for the products marketed under their brand name wherein their products are manufactured at third-party manufacturing unit is valid and is allowed for participation in the bids floated on GeM. The Manufacturer's Authorization in all such cases wherein the manufacturing is done by a third party shall be issued by the Brand owner / OEM and not by the third-party manufacturing unit mentioned in the BIS certificate.
- (z) **Bid Splitting:** In case of critical / vital / safety / security nature of the item, and / or large quantity under procurement and / or urgent delivery requirements and / or inadequate vendor capacity, Buyer may decide to have more than one source of supply. In such cases Buyer may opt for Bid Splitting while creating the bid on GeM, clearly indicating the Bid Splitting ratio in which order will be split among L-1, L-2, L-3 etc as per ratio of splitting pre-disclosed in the bid . After technical and financial evaluation, before splitting the quantity, it should be ensured by the Buyer that the L1 price is reasonable. After deciding the acceptable reasonable price, L1 would be awarded contract for at least the first / highest percentage indicated in the bid splitting ratio. For the rest of the bid quantity, the L-1 rates / lowest accepted rate will be counter offered to the next higher quoting bidder(s) for price matching. On acceptance of the counter offer, the order will be placed on next higher

quoting bidder(s) for the respective percentage. In case of non-acceptance of the counter offer by the next higher quoting bidder(s), a similar offer shall be made to L3 and L4, and so on. In case counter offered rates are not accepted for ratio of splitting quantity as per bid document by any of the subsequent bidders, the left over quantity will be divided between bidders who have accepted the rates in the ratio of their originally allocated quantities subject to their confirmation and after getting consent on mutually agreed delivery schedule for the additional quantity.

5. Contract(s):

Following documents shall be construed to be part of the contract generated through GeM:

- i. Scope of supply including price as enumerated in the Contract Document.
- ii. General Terms and Conditions (GTC).
- iii. Product / Service specific Special Terms and Conditions (STC).
- iv. Product / Track / Domain Specific STC of Particular Service including its SLA (Service Level Agreement)
- v. Bid / RA specific Additional Terms and Conditions (ATC).

The Terms and Conditions stipulated in STC & SLA will supersede those in GTC and Terms and Conditions stipulated in ATC will supersede those in GTC and STC in case of any conflicting provisions.

6. Prices:

- i. **Offer price on GeM portal:** The prices of the offered Goods or Services shall be firm and fixed at any point of time and shall be indicated in INR for each accounting unit. The Seller can choose to offer Goods or Services with uniform all inclusive unit price for deliveries at locations across India on All India basis or for specified locations selected at the time of product listing. As such, for supply of Goods contract, no additional charges such as local levies / transportation / loading unloading charges etc., shall be payable over and above the contract price. For selected freight intensive products, as notified on GeM, the Seller may quote unit price inclusive of GST with delivery charge(s) (including transportation, loading unloading and local levies) payable extra as defined in the relevant categories. In

respect of items requiring installation and / or commissioning and other services (as indicated in technical details of the item), the charges for the same shall also be included in the offered price on GeM.

Once a Buyer carts a particular quantity of offered Goods / Service, during carting period as notified from time to time on GeM, rates for carted quantity, for that buyer, are frozen for the period as specified on the portal against any upward revision by seller. However, advantage of any downward revision in the offer price of carted item shall be automatically provided to the buyer.

- ii. **Offer price in e-bidding:** Bidder is required to indicate offer price in the price schedule as provided in the bidding document. Complete breakup of price as required must be indicated. However evaluation of the bid shall be on the basis of total all inclusive, landed price at consignee destination (unless otherwise specified in the ATC).
- iii. **Offer price in RA:** Bidder is required to indicate total offer price. Evaluation of the bid shall be on the basis of total all inclusive, landed price at consignee destination (unless otherwise specified in the ATC). Successful bidder shall have to provide complete breakup of the quoted price in the required price bid format before award of contract.

7. Performance Security and Performance:

- i. *There shall be no Performance security / PBG requirement for contracts:*
 - a) *Placed under Direct Purchase / L-1 Purchase Option under Para (i) and (ii) of GFR rule 149;*
 - b) *Placed through Bids / RA with estimated bid value up to Rs 5 Lakh (in case of Goods contracts); and*
 - c) *Placed through Bids / RA with estimated bid value up to Rs 5 Lakh (in case of Services contracts)*
- ii. In case of contracts placed following e-Bidding / RA, Performance Security / Performance Bank Guarantee (PBG) (in format provided on GeM) valid for 2 months beyond the date of completion of all contractual obligations including warrantee obligations, will be obtained from the successful Bidder, for ensuring due performance of the contract. GeM recommends quantum of Performance Security @ 2% of the value of contract. The Buyer also has the option to select Performance Security between 2% to 10%. While finalizing e-Bid / RA, Buyer shall indicate the % of Performance Security required to be submitted by successful bidders. In case of any extension of contract

obligation period, the seller shall be liable to suitably extend the validity of the Performance Security.

Such Performance Bank Guarantee, in prescribed format, from a scheduled commercial bank must be submitted by Seller to the Buyer within 15 days of award of contract on GeM. The payments to the seller shall become due only after receipt of Performance Bank Guarantee by the Buyer and verification of its genuineness.

If the Seller fails or neglects to observe or perform any of his obligations under the contract it shall be lawful for the Buyer to forfeit either in whole or in part, the Performance Security furnished by the Seller.

If the Seller duly performs and completes the contract in all respects the Buyer shall, refund the Performance Security to the Seller within 30 days of completion of all contractual obligations by the Seller.

8. Duties & Taxes:

- i. Offer Prices on GeM shall be on all inclusive basis i.e. including all taxes, duties, local levies / transportation / loading-unloading charges etc. In the case of Bid / RA, complete break-up of the quoted price in the required price bid format shall furnished by the Bidder, before award of contract.
- ii. Statutory variation in the rate of GST, taking place between the date of award of contract and the original / refixed delivery period, shall be to the Buyer's account. For claiming any change in price due to such Statutory variation, the seller shall have to lodge claim before the Buyer providing documentary evidence of change in rate of GST taking place after the date of award of contract and the date of supply within the original / refixed delivery period. Buyer shall issue necessary amendment in the contract to enable generation of supplementary invoice or revised invoice as the case may be.
- iii. No increase in price on account of statutory increase in the rate of GST taking place during the period of delivery period extension with liquidated Damages shall be admissible. Nevertheless the Buyer shall be entitled to the benefit of any decrease in price on account of reduction in GST taking place during extended delivery period.
- iv. The Bill Form / On-line invoice shall be generated by the Seller which may inter-alia include the following confirmations from the Seller:

- a. Certified that the Goods and Services Tax (GST) charged on this Bill is not more than what is payable under the provision of the relevant Act or the Rules made there under.
 - b. Certified that the goods on which GST has been charged have not been exempted under the GST Act or the rules made there under and the charges on account of GST on these goods are correct under the provisions of that Act or the Rules made there under.
 - c. Certified that the Seller is registered with above indicated GSTIN as dealer in the State where in their Billing address is located for the purpose of GST.
 - d. The on-line bill form / invoice generated on GeM is not a replacement for the GST invoice. The proper GST invoice as per requirements of GST rules shall be sent by the seller to the buyer / consignee directly along with the Goods / Services as and when deliveries are made to the consignee.
- v. Seller shall comply with all the necessary statutory compliances including but not limited to providing GST invoices or other documentation as per GST Law relating to the supply of Goods or Services, uploading the details of the invoices, payment of taxes, timely filing of valid statutory returns for the tax period in the GST portal. In case the Input Tax Credit of GST is denied or demand is recovered from Buyer on account of any act/ omission of the Seller in this regard, the Seller shall be liable in respect of all claims of tax, penalty and / or interest, loss, damages, costs, expenses and liability that may arise due to such non-compliance. Buyer shall have the right to recover such amount from any payments due to the Seller or from Performance Security, or any other legal recourse from the said Seller. If any tax is required to be paid by the Seller in pursuance of any demand from tax authorities, on account of Seller's suppression of facts, fraud or wilful misstatement of facts while offering the products or submitting the bids, then the same shall not be passed on to Buyer through debit notes or Invoices or Supplementary Invoices and the seller shall be solely liable for payment of the same.

9. Integrity Pact:

All the Users in GeM i.e. Seller as well as Buyer agree not to indulge in any corrupt practices including without limitation any activity or action to influence the transaction on any aspect of contract and commit to take all measures necessary to prevent corruption maintaining complete transparency and fairness in all

activities related to GeM. Users agree to follow and adhere with the Integrity Pact guidelines provided on GeM Portal.

10. Guarantee And Warrantee:

- i. The Goods/Services supplied under the Contract(s) shall be in accordance with the contract specifications & quality and the Goods shall be brand new and have standard Guarantee/Warrantee for one year period from the date of final acceptance by the consignee unless otherwise specified in category specifications, specific Bid/RA . Seller, at the time of listing their product on GeM portal or offering their products against any Bid / RA, may accordingly provide longer Guarantee/Warrantee period (i.e. more than 1 year) and in such case, Guarantee/Warrantee period stipulation made in category specifications / Bid / RA document, shall prevail over standard Guarantee / Warrantee period of 1 year stipulated in these General Terms and Conditions.
- ii. Notwithstanding the fact that the Buyer or its Quality Assurance Officer may have inspected and/or approved / accepted the said Goods, it is further guaranteed that if during the said guarantee / warrantee period, the Goods be discovered not to conform to the requisite description and quality and/or not giving satisfactory performance or have deteriorated, and the decision of the Buyer in that behalf shall be final and binding on the Seller and the Buyer shall be entitled to call upon the Seller to rectify and/or replace the Goods or such portion thereof as is found to be defective by the Buyer within 7 days. Otherwise, the Seller shall pay to the Buyer such compensations that may arise by reasons of the warranty therein contained. In cases requiring Spares, the Seller guarantees that they will supply Spare Parts, if and when required on agreed basis for an agreed price for a minimum period of three years from the date of expiry of warrantee period (unless otherwise specified in STC / ATC). The agreed basis could be, including but without any limitation, an agreed discount on the published catalogue or an agreed percentage of profit on the landed cost. The aforesaid provisions made specifically for Goods, shall also be applicable for Services to the extent the same are practically possible.

11. Buyer / Consignee's Right Of Rejection (Return Policy):

- i. The Goods delivered shall bear the self certified Manufacturer's/Seller's Warranty/Guaranty. Buyer / Consignee shall have the right to inspect the supplied Goods themselves and/or through their appointed agency at consignee's own cost, at Consignee's site(s) after receipt and accept or reject

on proper justification any consignment of the Goods received within a period of 10 days (unless otherwise specified in STC or ATC) of receipt of consignment of goods. The date of receipt shall be reckoned from the date of receipt of the Goods as notified in the Provisional Receipt Certificate (PRC) which will be issued online by consignee immediately after receipt of Goods.

- ii. In case of Service contract, the Buyer reserves right to reject the same in conformance with the terms and conditions of the agreed Service Level Agreement (SLA). However, such right to reject services offered by the Seller under the contract shall be exercised by the Buyer within 10 days (unless otherwise specified in STC or ATC) of the date of receipt of the Service. The date & time of start and completion of the Service, shall be indicated by the Seller while raising on-line invoice for a specified period of Service as per Service Level Agreement (SLA). The date of such invoice or the date of completion of the service, whichever is later shall be reckoned as date of receipt of the Service.
- iii. On Acceptance / Part Acceptance or Rejection of Goods / Services, Consignee will issue an on line 'Consignee's Receipt cum Acceptance Certificate' (CRAC), which will form the basis of Payments to the Seller.
- iv. No payment shall be made for rejected goods or services. After intimation of the rejection / part rejection by the Buyer/ Consignee, the Seller shall be liable to remove / lift back such rejected Goods within 10 days without any extra charge/cost to the Buyer / Consignee failing which suitable ground rent / warehousing charges would be payable by the Seller to the Buyer /Consignee. If the Seller fails to remove / lift back such rejected Goods within reasonable time period, the Buyer / Consignee shall have the right to dispose off such rejected goods at the risk and cost of the seller.

12. Payment Authority and Payment Terms:

Payments shall be made to the Seller in the manner below:

i. For Goods :

In case of goods, 100% payment will be released within ten (10) days of issue of consignee receipt-cum-acceptance certificate (CRAC) and on-line submission of bills unless otherwise specified in STC / ATC.

ii. For Services:

In case of services, 100% payments on the basis of monthly (unless otherwise specified) bills will be paid within ten (10) days of issue of consignee receipt-cum-acceptance certificate (CRAC) and on-line submission of bills unless otherwise specified in STC / ATC.

13. Terms of Delivery:

All the Goods or Services in the GeM shall be offered on Free Delivery at Site basis including loading/unloading. In respect of items requiring installation, commissioning and other services in the scope of supply (as indicated in respective product category specification / STC / ATC), the cost of the same shall also be included in the offer price.

14. Delivery Period

Seller shall indicate the quantity which can be supplied over the specified time period(s). The Seller would offer these details, which would constitute the part of the awarded Contract(s) in the GeM and would make a binding Contract between the Seller & the Buyer. Any modification thereto shall be mutually agreed and incorporated in the Contract. This Delivery Period/Time shall be deemed to be essence of the Contract and delivery must be completed not later than such date(s).

15. Extension of Delivery Period and Liquidated Damages:

Buyer may, on the request of the Seller or otherwise, extend the delivery date suitably subject to the following conditions:

- i. The original Delivery Period may be re-fixed by the Buyer without any Liquidated damages subject to Force Majeure conditions mentioned below and also on the ground/reasons of delay attributable to the Buyer / Consignee.
- ii. For other cases, provided the price trend is not lower, the Delivery Period may be suitably extended for which an amount equal to the Liquidated Damages for the extended period(s) for delay in the supply of the Goods/Services after the expiry of contract delivery period /re-fixed delivery period, shall be recovered from the Seller as mentioned hereinafter for the extended period. No increase in price on any ground after the original/re-fixed delivery date shall be admissible during such extended period(s). Nevertheless the Buyer shall be entitled to the benefit of any decrease in price on account of reduction in GST taking place during extended delivery period.

iii. **Liquidated Damages:** If the Seller/Service Provider fails to deliver any or all of the Goods/Services within the original/re-fixed delivery period(s) specified in the contract, the Buyer will be entitled to deduct/recover the Liquidated Damages for the delay, unless covered under Force Majeure conditions aforesaid, @ 0.5% of the contract value of delayed quantity per week or part of the week of delayed period as pre-estimated damages not exceeding 10% of the contract value of delayed quantity without any controversy/dispute of any sort whatsoever.

iv. **Force Majeure Conditions :**

If at any time during the continuance of the Contract, the performance in whole or in part by either party of any obligation under this Contract shall be prevented or delayed by the reasons of any war, hostility, acts of the public enemy, epidemics, civil commotion, sabotage, fires, floods, explosion, quarantine restrictions, strikes, lockouts or act of God provided notice of happening of such event duly evidenced with documents is given by one party to the other within 10 days from the date of occurrence thereof, neither party shall be by reasons of such event, be entitled to terminate the Contract nor shall either party have any claim for damages against the other in respect of such non-performance or the delay in performance, and deliveries under the contract shall be resumed as soon as practicable after such event has come to an end or ceased to exist, and the decision of the Buyer as to whether the deliveries have been so resumed or not, shall be final and conclusive, Provided further that if the performance in whole or part of any obligation under this contract is prevented or delayed by reason of any such event for a period exceeding **10 days**, either party may at its option terminate the contract provided also that the Buyer shall be at liberty to take over from the Seller at a price to be fixed by Buyer, which shall be final, all unused, undamaged and accepted material, bought out components and Goods in course of manufacture in the possession of the Seller at the time of such termination or such portion thereof as the Buyer may deem fit excepting such materials, bought out components and Goods as the Seller may with the concurrence of the Buyer elect to retain.

16. Dispute Resolution Between Buyer and Seller:

AMICABLE SETTLEMENT:

In the event of any question, dispute or difference arising connection with the Contract, the Parties shall use their respective reasonable endeavour to settle any dispute amicably. If a Dispute is not resolved within 30 days after written notice of

any dispute by one Party to the other, the same shall be resolved through the mechanism of a co-ordination committee to be formed by the Buyer and Seller/Service Provider and to be chaired by the Primary User of Buyer Organization/Department along with representatives from Buyer Department and Seller.

ARBITRATION:

In the event of any question, dispute or difference arising under the terms and conditions of the contract placed through GeM, the same shall be referred to the sole arbitration by an officer nominated as Arbitrator by the Primary Buyer of the concerned Buyer Organization. It will be no objection that the arbitrator is a Government Servant and that he had to deal with the matters to which the contract relates or that in the course of his duties as a Government servant he has expressed views on all or any of the matters in dispute or difference. The award of the arbitrator shall be final and binding on the parties to the contract. The arbitration shall be governed as per Indian Arbitration and Conciliation Act 1996 as amended up to date. The place for arbitration shall be at the place from where contract has been placed by the Buyer or at the place of Primary Buyer as decided by the Primary Buyer.

In the event of the Arbitrator dying, neglecting or refusing to act or resigning or being unable to act for any reason, or his award being set aside by the court for any reason, it shall be lawful for the Primary Buyer to appoint another arbitrator in place of the outgoing arbitrator in the manner aforesaid.

In respect of all contract placed through GeM, the dispute would not be referred or entertained by Micro and Small Enterprise Facilitation Council, Consumer Forum or any other adjudication forum.

All disputes in connection with the Contract, shall be subject to the exclusive jurisdiction of the Court within the local limits of whose jurisdiction, the place from where Contract was issued is situated

GeM SPV would not be a party to any such dispute/matter.

In case any Seller / Service provider makes GeM a party / respondent in any case involving any dispute between Buyer and Seller arising out of a concluded contract or arising out of bidding process initiated / concluded by the Buyer on GeM, it would be obligatory on the part of the Buyer to represent GeM also through their Counsel / Lawyer in the proceedings before the legal authority and ensure timely filing of replies / affidavits etc provided by GeM also through their Counsel / Lawyer before the concerned legal authority during the course of

litigation. A standard reply on behalf of GeM, covering following aspects shall be incorporated in all replies / affidavits filed by the Buyer in such cases:

“Government e-Marketplace is a National Public Procurement Portal; an end-to-end online Marketplace for Central and State Government Ministries / Departments, Central & State Public Sector Undertakings (CPSUs & SPSUs), Autonomous institutions and Local bodies, for procurement of common use goods & services. Prima facie, the dispute in the present case appears to be between the Buyer and Seller arising out a contract placed / bid created by the Buyer on Government e-Marketplace. As per Clause 16, Clause 17 and Clause 22 of the General Terms and Conditions of Government e-Marketplace (duly accepted by the Buyer and Seller), GeM is not to be made a party to any dispute between the Buyer and the Seller. As such Government e-Marketplace is liable to be deleted from the array of parties.

In light of the above, we request your goodself to kindly delete Government e-Marketplace from the array of parties.”

17. Laws Governing the Contract:

- i. The contract shall be governed by the laws of India for the time being in force.
- ii. Irrespective of the place of delivery, the place of performance or the place of payment under the contract, the contract shall be deemed to have been made at the registered address of the Buyer and / or Primary Buyer.
- iii. Jurisdiction of Courts: The courts of the place from where the contract has been made shall alone have jurisdiction to decide any dispute arising out of or in respect of the contract.
- iv. GeM SPV would not be a party to any such litigation.
- v. In case any Seller / Service provider makes GeM a party / respondent in any case involving any dispute between Buyer and Seller arising out of a concluded contract or arising out of bidding process initiated / concluded by the Buyer on GeM, it would be obligatory on the part of the Buyer to represent GeM also through their Counsel / Lawyer in the proceedings before the legal authority and ensure timely filing of replies / affidavits etc provided by GeM also through their Counsel / Lawyer before the concerned legal authority during the course of litigation. A standard reply on behalf of GeM, covering following aspects shall be incorporated in all replies / affidavits filed by the Buyer in such cases:

“Government e-Marketplace is a National Public Procurement Portal; an end-to-end online Marketplace for Central and State Government Ministries / Departments, Central & State Public Sector Undertakings (CPSUs & SPSUs), Autonomous institutions and Local bodies, for procurement of common use goods & services. Prima facie, the dispute in the present case appears to be between the Buyer and Seller arising out a contract placed / bid created by the Buyer on Government e-Marketplace. As per Clause 16, Clause 17 and Clause 22 of the General Terms and Conditions of Government e-Marketplace (duly accepted by the Buyer and Seller), GeM is not to be made a party to any dispute between the Buyer and the Seller. As such Government e-Marketplace is liable to be deleted from the array of parties.

In light of the above, we request your goodself to kindly delete Government e-Marketplace from the array of parties.”

18. Limitation of Liability:

Notwithstanding anything contained in this agreement, no party will be liable for any special, incidental or consequential damages arising out of or in connection with this agreement or any breach hereof (including for loss of data or profits, or cost of cover), whether or not such party has been advised of the possibility of such damages, and whether under a theory of contract, tort (including negligence) or otherwise; except for liabilities arising out of any violation, misappropriation or infringement of a party's intellectual property rights, or from a breach by either party of its obligation. In no event will either party's aggregate liability arising out of or in connection with this agreement or any breach hereof (whether under a theory of contract, tort (including negligence), warranty or otherwise) exceed the Contract Price entered into the Contract between Buyer and Seller.

19. Termination for Default:

If the Seller does not perform its obligations within the Delivery Period/Date mentioned in the Contract, the same would constitute the breach of the Contract and the Buyer shall have the right to Cancel or withdraw the Contract for the unsupplied portion after the expiry of the original or re-fixed delivery date or period stipulated in the Contract. Such cancellation of contract on account of non-performance by the Seller would entitle the Buyer to forfeit the performance security besides other actions such as downgrading the Seller's rating or debarment from the GeM for specified period as decided by GeM on merits.

20. Closure of Transaction:

After satisfactory completion of all the obligations under the Contract and release of payments for the goods / services, the transaction shall be treated as closed.

21. Grounds for Administrative Action

(i) Administrative actions may be taken by GeM against the Buyer or the Seller either suo-moto on the basis of the platform mechanisms identified through analytics or on the basis of a complaint or report made to GeM by any stakeholders or any third party information or upon Court order, inter –alia, for non-adherence to the GeM Website Policies including Terms and Conditions and the Incident Management Policy published on the GeM Website.

(ii) The Seller would be liable for administrative actions such as suspension / debarment / removal from GeM, if they fail to abide by any of the Website Policies including the terms & conditions stipulated in this document and/or on anyone or more of the following grounds:

- (a) Listing the products/services not in the relevant categories and/or listing the same with vague/conflicting product specifications/details and irrelevant product photographs.
- (b) Offering Goods / Services without having proper authorization
- (c) Supplies goods of inferior/ substandard quality
- (d) Supplies or offers to supply refurbished or counterfeit or fake products
- (e) Withdraws or modify or impairs or derogates from the bid in any respect within the period of validity of its bid;
- (f) Seller furnishes inaccurate, false, misleading or forged or fails to furnish any information / documents, within the prescribed time limits, to GeM or to a Buyer, including during e-Bidding/ RA process;
- (g) Fails to furnish requisite performance security / PBG within stipulated time required as per e-bid / RA conditions;
- (h) Fails to update GeM about any change in information furnished within the prescribed time limits;
- (i) Executes services without conforming to requirement given in Service Level Agreement (SLA);
- (j) Fails to execute an order/ contract or fail to execute it satisfactorily
- (k) Is declared bankrupt or insolvent;
- (l) Fails to produce the requisite documents/ information during the course of inspection / assessment at any stage;

- (m) Performs any activity which is listed as prohibited activities on GeM.
- (n) On any other ground for which, in the opinion of GeM, the retention of the seller or any of its offered product in GeM is not in Public Interest.
- (o) The grounds mentioned above are illustrative only. Users are also advised to read the list of prohibited activities published on the website.
- (iii) Notwithstanding anything contained in the GTC, GeM reserves the right to cancel or annul the registration of any Seller or remove any of the Good/Services listed by a Seller on the GeM Website to comply with any provision of the Applicable Laws and / or Court Orders.
- (iv) GeM may take an administrative action in terms of the GeM Website Policies against a Buyer which may include reporting of any breach or misconduct to the Buyer Primary User and/or to the competent authority and GeM reserves the right to review the rating of such Buyer, and / or block Buyer's account for such time as considered appropriate by GeM.
- (v) The Seller and the Buyer understands that the grounds for administrative action as provided under the Contract are only indicative and additional grounds may be provided under the GeM Website Policies including the Incident Management policy. The Seller / Buyer warrants to abide by all additional grounds as may be specified by GeM in the GeM Website Policies from time to time.

22. Role of Government E- Marketplace - Gem SPV

Government e-Marketplace – GeM SPV is the owner of the GeM portal which monitors and supervises all the business transactions on the portal. The role and responsibilities of the company are as under:

- a. To develop, operate and maintain technology driven e-marketplace, through a Managed Service Provider (MSP), to be used by government agencies for procurement of various goods and services in a transparent and efficient manner.
- b. Overall supervision and monitoring of GeM portal operations, policy management, finalization and implementation of various business processes and work flows in adherence with the applicable law and executive orders

issued from time to time . To provide tools for on-line Bidding, on-line Reverse Auction and Business Analytics Tools on GeM.

- c. To work continuously for improvements in the Business Processes and Work Flows for various activities / functions on GeM based on feedback from various stakeholders to enhance transparency, efficiency, competitiveness, equality, economy in procurement of goods and services by government agencies.
- d. To finalize General Terms and Conditions for sale and purchase of Goods and Services on GeM, Product / Service Specific Special Terms and Conditions, Special Terms and Conditions for Bunching of Goods / Services, Bid Specific Special Conditions, Project Specific Special Conditions etc.
- e. To finalize, upload and approve Technical Specification Frameworks for various item / service categories on GeM and to monitor conformity of offered products to the larger framework so finalized and uploaded.
- f. To decide addition / deletion of any of the offered product(s)/Product category (ies) and their framework of technical parameters on GeM.
- g. To work and co-ordinate with different Organizations/Departments / Agencies for integration of their Databases with the GeM portal on real time basis for the purpose of verification/authentication of data entries made by stakeholders.
- h. To offer and manage Demand Aggregation services for identified categories across buyers with assured reasonability of price, recommending for placement of orders by individual buyers
- i. To co-ordinate with MSP for conducting workshops for the various Stakeholders in capacity building and in change management associated with the implementation of technology enabled procurement process.
- j. To monitor MSP that the Buyers, Sellers and Service Providers are being assisted properly by them to onboard their goods and services on the GeM platform.
- k. To identify and offer services of 3rd parties for Vendor Assessment relating to technical, financial capacity, past experience of sellers including manufacturing / testing facilities / quality control arrangement(s) of manufacturing premises and/or any of the premises related to manufacturing process of products / services offered by the seller / service provider on GeM.

- l. To identify and offer services of 3rd parties for testing and certifying the quality of the product offered/ supplied, through documents, test reports/ certificates, testing at any independent lab or through inspection/testing by its authorized representative/s at firm's premises or at user's premises, that buyer choose to use.
- m. Overall monitoring and management of Call Centre/Help desk operations being provided by the MSP.
- n. Removal / debarring the Sellers/Buyers and Goods / services in GeM.
- o. Management of complaints and their redressal mechanism in GeM (not disputes related to concluded contracts).
- p. To identify, integrate and manage MoUs with verifying, certifying and validating entities across government(s) and also professional agencies to reinforce the online paperless, contactless and cashless system on GeM.
- q. To issue Notices, Circulars, News, Flashes, Updates etc in GeM
- r. Reporting and MIS mechanism in GeM
- s. Any other related activities in the GeM
- t. In exceptional circumstances, for ensuring propriety of procurement processes or to obviate possible misuse of GeM functionalities, GeM SPV as GeM Admin may keep any Bidding / RA process on hold for some time as considered appropriate.
- u. To take approved User Charges from Buyers and Sellers for the various transactions on the GeM portal as decided and notified on the GeM portal.

23. Miscellaneous Provisions

- a. **Assignment:** Users understand and agree that the GTC, STC and ATC provisions, rights and obligations granted by GeM are non- transferrable or assignable by the User to any third party, without the prior written consent of GeM. If same is permitted by GeM, all the conditions, rights and obligations of the GTC or any on-going STC/ATC shall also be binding upon such third party assignee besides the User.
- b. **Indemnification:** The Seller shall at all time indemnify Buyer against all suits and claims which may be made in respect of the goods/services for infringement of any right protected by patent, registration of designs or trade mark. Provided always that in the event of any claim and suit in respect of alleged breach of patent, registered designs or trade-mark being

made against the Buyer, the Buyer shall notify the Seller/ Service Provider of the same who shall at its own expense either settle any such dispute or conduct and litigation that may arise there from.

Buyers and Sellers agree to indemnify, defend and hold harmless GeM, its officials, Managed Service Provider (herein after individually and collectively referred to as "indemnified parties") from and against any and all losses, liabilities, claims, suits, proceedings, penalties, interests, damages, demands, costs and expenses (including legal and other statutory fees and disbursements in connection therewith and interest chargeable thereon) asserted against or incurred by the indemnified parties that arise out of, result from, or in connection with

- i. Breach of the contract(s); or
- ii. Any claims made by any third party due to, or arising out of, or in connection with, use of the Website; or
- iii. Any claim made by any third party regarding content/ information or materials provided by Seller cause any damage to a third party; or arising out of, or in connection with, use of the Website.
- iv. Violation of any intellectual property rights or any other rights.

Once GeM notifies the Buyer/ Seller of such claims, they shall defend and indemnify GeM for the same. Further, in no case they shall compromise or settle any claim or admit any liability on the part of GeM without the express or prior written consent of GeM which can be withheld or denied or modified by GeM in its sole discretion or as per the Applicable Laws.

- c. **Severability:** If due to any change in Applicable laws, certain part of the GTC or any applicable STC or any provisions of the GeM policies or portions thereof, becomes unenforceable, the remaining provisions shall continue in full force and effect so as to give effect to the intent of the parties.
- d. **Website Terms and Policies Updation:** Buyers and Sellers are advised to check the website terms and conditions as well as policies such as Privacy Policy and the Website Disclaimer at all times, as GeM may update the Website and such terms from time to time.
- e. **List of Prohibitive Activities (Suggestive And Non-Exhaustive):**

LIST OF PROHIBITIVE ACTIVITIES: The following is an indicative list of prohibitive activities which the Buyers and the Sellers registered on GeM platform shall not perform on the GeM platform. A breach of any of the prohibited activities shall give the right to GeM under the Applicable Laws or in terms of these GTC or the GeM Website Policies to take administrative action which may include partial or permanent disabling of account on GeM Website, debarment etc. Additionally, GeM may remove any non-compliant information and reserves the right to preserve and share with the appropriate authority such information and associated records for investigation purposes. The Buyer and the Seller understand that this list is only indicative and additional activities may be prohibited under the GeM Website Policies. The Buyers and the Sellers shall undertake to provide their full support that may be required by GeM for removal and disabling of the non compliant information. The prohibited activities include:

- (i) Indulging in cyber crime or other criminal activities which can become a threat to GeM, GeM Website, to the Government of India or to any State Government or Government Agency.
- (ii) Advertising, exhibiting, representing, publishing, pronouncing, listing, delivering, offering to sell or selling any kind of Goods/Services which can cause any kind of infringement or disparagement of intellectual property rights.
- (iii) Selling refurbished, counterfeit and/or fake Goods / Services under a brand or misusing others brand name.
- (iv) Offering to sell or selling above the MRP any Goods or misrepresenting the MRP.
- (v) Delivering some other Goods or Services instead of the Goods or Services Contracted for or delivering empty parcels or used Goods in breach of the terms of the Contract.
- (vi) Offering to sell or selling freebies which are 'Not for sale' Goods.
- (vii) Listing of the Goods on GeM Website without authorization to sell Goods manufactured by the OEM in open market or without proper authorisation, if any required, for providing the Service.
- (viii) Listing of the Goods or Services is done on GeM Website without guarantee/warranty or without a genuine guarantee/warranty.

- (ix) Listing of the Goods or Services in irrelevant or inappropriate categories or with vague or conflicting specifications or description (including descriptive or pictorial description).
- (x) The Buyer /Seller registering on GeM and/or offering or buying the Goods and/or Services and/or participating in e-bidding/reverse auction on GeM, without the requisite authorization to enter into contract on behalf of the concerned legal entity. Failing which such individual(s) shall be individually liable for its actions and also for any liability arising out of such actions.
- (xi) If any Seller has been debarred from GeM then such Seller or their authorized sellers shall also not be permitted to register and offer/sell their products on GeM and / or participate in Bids / RA on GeM.
- (xii) Using GeM prices for making procurement outside GeM Portal.
- (xiii) Splitting of demands by creating multiple Bids/RAs of same goods / services or making repeated procurements of same goods/services through Direct Purchase / L-1 buying as per rule 149(i) and 9(ii) of GFR-2017.
- (xiv) Uploading goods / services containing information that —
 - (a) belongs to another person and to which the user does not have any right to;
 - (b) is grossly harmful, harassing, blasphemous, defamatory, obscene, pornographic, paedophilic, libellous, invasive of another's privacy, hateful, or racially, ethnically objectionable, disparaging, relating or encouraging money laundering or gambling, or otherwise unlawful in any manner whatever;
 - (c) harm minors in any way;
 - (d) infringes any patent, trademark, copyright or other proprietary rights;
 - (e) violates any law for the time being in force;
 - (f) deceives or misleads the addressee about the origin of such messages or communicates any information which is grossly offensive or menacing in nature;
 - (g) impersonate another person;

- (h) contains software viruses or any other computer code, files or programs designed to interrupt, destroy or limit the functionality of any computer resource;
- (xv) threatens the unity, integrity, defence, security or sovereignty of India, friendly relations with foreign states, or public order or causes incitement to the commission of any cognizable offence or prevents investigation of any offence or is insulting any other nation.
- (xvi) Achieving or trying to achieve illegal access to features on GeM Website not specifically authorised or exceeding the scope of authorized access to or other features of the GeM Website;
- (xvii) Obstructing or causing GeM to lose (in whole or in part) the services provided by any internet service provider ("ISPs") or carrying out any cyber security incident;
- (xviii) Sending unsolicited emails, bulk messaging, auto messaging, junk email, spam and like.

24. Incident management Policy on GeM: GeM is a trust based system and self-declaration is the key, along with a strong automated process to penalize any deviant behaviour on part of Sellers / Buyers. For this purpose, deviations from the terms and conditions of procurement on GeM, including general terms and conditions, special and additional terms and conditions and any other relevant Government rules and guidelines, are termed as "deviation". A deviation can occur while listing the products on GeM, at pre-contract stage, during bidding or at post contract stage on GeM. The mechanism for reporting and initiating action on such deviation has been detailed in the Incident Management Policy available on GeM portal under Resources. All stake holders of GeM shall be bound by the actions as detailed in the Incident Management Policy.

All administrative actions under this Incident management Policy, taken by GeM against any of the stakeholders shall not cause any limitation on the legal and/or contractual remedies including any financial recoveries, available to Buyers/Sellers under the Terms and Conditions of contract and/or GeM policies. In case the Buyer / Seller choose to pursue any of these remedies, GeM shall not be made party to such proceedings / remedial actions taken by Buyer/Seller under the contractual provisions.

25. Use of Aadhaar Number in GeM: Purpose of the Aadhaar authentication in GeM is to identify the user using eKYC. GeM has provisioned the option for Sellers and Buyers to provide virtual Aadhaar ID instead Aadhaar number. GeM receives First Name, Last Name, Mobile Number, Email ID, DOB and Gender details. It is used to link the mobile number with the user who is registering on GeM; on which subsequently OTP is sent for

achieving the property of non-repudiation in different artefacts / documents generated on GeM. GeM has provisioned an alternative Identity Information option through PAN based verification to Sellers.

26. Compliance of Restrictions under Rule 144 (xi) of GFR 2017: Restrictions on procurement from a bidder of a country which shares a land border with India

- I. Any bidder from a country which shares a land border with India will be eligible to bid in this tender only if the bidder is registered with the Competent Authority.
- II. "Bidder" (Seller / Service Provider) means any person or firm or company, including any member of a consortium or joint venture (that is an association of several persons, or firms or companies), every artificial juridical person not falling in any of the descriptions of bidders stated hereinbefore, including any agency branch or office controlled by such person, participating in a procurement process.
- III. "Bidder from a country which shares a land border with India" for the purpose of this Order means: -
 - a. An entity incorporated, established, or registered in such a country; or
 - b. A subsidiary of an entity incorporated, established, or registered in such a country; or
 - c. An entity substantially controlled through entities incorporated, established, or registered in such a country; or
 - d. An entity whose beneficial owner is situated in such a country; or
 - e. An Indian (or other) agent of such an entity; or
 - f. A natural person who is a citizen of such a country; or
 - g. A consortium or joint venture where any member of the consortium or joint venture falls under any of the above
- IV. The beneficial owner for the purpose of (iii) above will be as under:
 1. In case of a company or Limited Liability Partnership, the beneficial owner is the natural person(s), who, whether acting alone or together, or through one or more juridical person, has a controlling ownership interest or who exercises control through other means. Explanation—
 - a. "Controlling ownership interest" means ownership of or entitlement to more than twenty-five per cent. of shares or capital or profits of the company;
 - b. "Control" shall include the right to appoint majority of the directors or to control the management or policy decisions including by virtue of their shareholding or management rights or

shareholders agreements or voting agreements;

2. In case of a partnership firm, the beneficial owner is the natural person(s) who, whether acting alone or together, or through one or more juridical person, has ownership of entitlement to more than fifteen percent of capital or profits of the partnership;
3. In case of an unincorporated association or body of individuals, the

beneficial owner is the natural person(s), who, whether acting alone or together, or through one or more juridical person, has ownership of

or

entitlement to more than fifteen percent of the property or capital or profits of such association or body of individuals;

4. Where no natural person is identified under (1) or (2) or (3) above, the beneficial owner is the relevant natural person who holds the position of senior managing official;
 5. In case of a trust, the identification of beneficial owner(s) shall include identification of the author of the trust, the trustee, the beneficiaries with fifteen percent or more interest in the trust and any other natural person exercising ultimate effective control over the trust through a chain of control or ownership.
- V. An Agent is a person employed to do any act for another, or to represent another in dealings with third person.
- VI. The successful bidder shall not be allowed to sub-contract works to any contractor from a country which shares a land border with India unless such contractor is registered with the Competent Authority.

Any false declaration and non-compliance of the above would be a ground for immediate termination of the contract and further legal action in accordance with the laws.

Clause 27: Caution Money Deposit:

(i) All sellers on GeM are required to deposit a one-time amount as under as caution money:

- a) Seller Turnover less than 1 Crore: Rs 5,000/-
- b) Seller Turn over > 1 Crore but < 10 Crore: Rs 10,000/-
- c) Seller Turn over > 10 Crore: Rs 25,000/-

(ii) The above caution money shall remain at the disposal of GeM SPV. This can be forfeited in part or in full (as per approval of CEO (GeM)) in following circumstances:

- a) Seller rejects or does not accept any Direct Purchase / L-1 Purchase order within defined timelines leading to order auto cancellation.
- b) Failure of the seller in executing any GeM contract or if the Seller fails or neglects to observe or perform any of his obligations under the contract (applicable only in respect of contracts that did not have provision of Performance Security / PBG).

- c) Withdraws any bid submitted on GeM within the period of validity of the bid.
- d) Fails to furnish requisite performance security / PBG as per GeM e-bid / RA conditions.

(iii) In case the Caution Money of any seller is forfeited in full or part and his caution money deposit goes below the threshold indicated in para 1 above, the seller account shall be put on hold till the seller re-coups the caution Money account to required value. Seller's stock will become zero for all categories and seller will not be allowed to update anything till the caution money is topped up to minimum required amount.

(iv) Forfeiture of caution money as per above shall be over and above any other actions taken against such sellers as per GeM Incident Management Policy and shall be without any prejudice to the rights and remedies available to GeM and / or Buyer as per provisions of the relevant contracts.

Clause 28: CMS 3.0 and OEM - Reseller responsibility matrix:

GeM has implemented enhanced Catalogue Management System (CMS 3.0) on GeM Portal. The Primary Objective of CMS 3.0 is to offer higher level of ownership & accountability to OEMs & its approved Resellers while maintaining Efficiency, Transparency & Inclusiveness of GeM. Complete and detailed Obligations and Privileges matrix of the different stakeholders in different quadrants is given in CMS document available on GeM Portal and OEMs and Resellers are bound to operate on GeM in compliance with the CMS document as updated from time to time.

1) CMS Quadrant 1 (CMS Q1): Product offers in categories under Q1 will be solely offered by GeM validated OEMs. OEM shall be exclusively responsible for maintaining currency and sanity of catalogue and its offer in the Market Place. OEM shall be absolutely and exclusively responsible and be legally liable for sanity and quality of offers including Warranty and After Sales Service obligations.

2) CMS Quadrant 2 (CMS Q2): OEMs as well as pre-Authorized Resellers can offer products in Q2. OEMs shall operate Market Place subject to providing its complete list of Open market authorized sellers along with formal commitment to list and maintain all appropriate and current Product Catalogue for pairing by its Resellers. OEM shall be absolutely and exclusively responsible and be legally liable for sanity and quality of catalogues including Warranty and After Sales Service obligations. Authorize Resellers shall be responsible for Pairing their offer with the already existing Product Catalogue created by the OEM. However, resellers can Update their Offer Price, Stock and Delivery Locations solely at their own discretion and shall be solely responsible for the same.

3) CMS Quadrant 3 (CMS Q3): Catalogue creation in categories under Q3 can be from OEMs and/or their Authorized Resellers concurrently. In case OEM has not created Product Catalogue, Authorized Resellers of OEMs are also permitted to do the same. However, OEM (when registered on GeM and taken OEM Dashboard) shall be responsible for Validating & verifying the Catalogue uploaded by Reseller, Maintaining the Catalogue by adding/updating the Specifications, MRP etc. specific to catalogue. OEM shall also assume all responsibility and legal liability for sanity and quality of offers including Warranty and After Sales Service obligations. However, resellers can Update their Offer Price, Stock and Delivery Locations solely at their own discretion and shall be solely responsible for the same.

4) CMS Quadrant 4 (CMS Q4): Catalogue creation in categories under Q4 can be done by OEMs as well as by any Reseller also. However, OEM (when registered on GeM and taken OEM Dashboard) shall be responsible for Validating & verifying the Catalogue uploaded by Reseller, Maintaining the Catalogue by adding/updating the Specifications, MRP etc. specific to catalogue. However, there is no requirement of any endorsement or authorization of the reseller by the OEM. Resellers can Update their Offer Price, Stock and Delivery Locations solely at their own discretion and shall be solely responsible for the same. Reseller will also be responsible for providing Replacement Warranty in case of Q4 products and Buyer shall not be required to take up with OEM for any warranty claims.

5) CMS (Special Category) : The Special Category is a specialized segment outside the four quadrants for select few categories that require a customized behavior such as Self-Help Groups (SHG) categories.

In Q3 and Q4, in case of re-sellers, if the reseller has not been approved as an authorized re-seller by the OEM on GeM, the re-seller is required to give an undertaking as under while uploading the product, while accepting any order and while participating in any bid:

“I hereby undertake that I have made arrangements for getting the stores from authorized distributor / dealer / channel partner of the OEM of the offered product. At the time of delivery of goods, I will provide necessary chain documents to prove that the supplied goods are genuine and are being sourced from authorized distributor / dealer / channel partner of the OEM. In case of any complaint from the Buyer / Consignee about genuineness of the supplied products, I shall be responsible for providing genuine replacement supplies.”

By uploading any product on GeM or accepting any order on GeM or by participating in any bid on GeM, the re-seller is deemed to have given above undertaking and is liable for compliance of the same.

Further in view of the on-line verification of Seller credentials by the OEM on GeM platform, there is no need for Buyer to ask for or insist on furnishing of OEM authorization in bids in respect of "OEM verified Catalogue" offered by "OEM Verified Reseller". OEM authorization is also not required to be sought and checked by Buyers in case of bids for products in Q1 or Q2.

Clause 29: One Bid per Bidder

A Bidder shall submit only one bid in a particular bidding process (unless otherwise allowed in the bid STC / ATC conditions). In case of a holding company having more than one independent manufacturing units or more than one unit having common business ownership / management, only one unit should quote. Similar restrictions shall apply to closely related sister companies. Bidder's sister/ Associated/ Allied concern(s) participating or applying against the same tender, shall lead to disqualification of Bidders. Sister/ Associated/ Allied concern means a company, society, partnership firm or proprietorship firm having one or more common persons as Director/ Partner/ Member/ Owner. A Bidder who submits more than one bid will cause all the proposals submitted in the particular bid to be disqualified. In relation to the above, a person will include firm(s) of Proprietorship / Partnership Firm / Limited Liability Partnership / Private Limited / Limited company / Society registered under Society's Act / Statutory Bodies / any other legal entity, as the case may be, & will be deemed to have submitted multiple bids in a particular bid if a person bids in any of the two formats given below:

- a) individual or proprietorship format and/or
- b) a partnership or association of persons format and/or
- c) a company format

Whereby,

- A company shall for this purpose include any artificial person whether constituted under the Indian laws or of any other country.
- A person shall be deemed to have bid in a partnership format or in association of persons format if he is a partner of the firm which has submitted the bid or is a member of any association of persons which has submitted a bid.
- A person shall be deemed to have bid in a company format if the person holds:
 - a) more than 10% (ten percent) of the voting share capital of the company which has submitted a bid, or
 - b) is a director and / or Key Managerial Personnel of the company which has submitted a bid, or
 - c) holds more than 10% (ten percent) of voting share capital in and/or is a director and / or Key Managerial Personnel of a holding company of that company which has submitted the bid.

By making a bid pursuant to the Tender Documents, the bidder / tenderer shall be deemed to have declared that the bidder / tenderer has not made any other bid or multiple bids as understood or deemed in terms of this clause.

All the bids of a bidder who has submitted multiple bids, as per the clause, shall be rejected and Earnest Money Deposit for all such bids shall be forfeited, not by way of penalty or liquidated damages but by way of reimbursement of the pre-estimated costs likely to be incurred by the buyer towards bidding process and in the scrutiny & evaluation of bids.

In addition to the above, bidders found to be in contravention to the said clause will be liable for administrative actions.

ADDITIONAL TERMS & CONDITIONS FOR WELDED PIPES

SI No	BHEL requirement																									
1	<p>SCOPE OF SUPPLY-</p> <p>i) Manufacture / Fabrication & Supply of welded pipes conforming to IS 3589 Gr.410 meeting BHEL drawing & technical requirements for YADADRI Project.</p> <p>ii) To be delivered at YADADRI project site</p> <table border="1" style="width: 100%; border-collapse: collapse; margin-top: 10px;"> <thead> <tr> <th style="width: 10%;">Item No.</th> <th style="width: 15%;">Material Code</th> <th style="width: 45%;">Item Description</th> <th style="width: 15%;">Qty in Meters</th> <th style="width: 15%;">Wt in MT</th> </tr> </thead> <tbody> <tr> <td style="text-align: center;">1</td> <td style="text-align: center;">159385490000</td> <td>PIPE DIA 219.1 X 6.0 IS3589-410MPA</td> <td style="text-align: center;">1300.00</td> <td style="text-align: center;">40.99</td> </tr> <tr> <td style="text-align: center;">2</td> <td style="text-align: center;">159385380000</td> <td>PIPE DIA 273.1 X 6.0 IS3589-410MPA</td> <td style="text-align: center;">350.00</td> <td style="text-align: center;">13.83</td> </tr> <tr> <td style="text-align: center;">3</td> <td style="text-align: center;">159385390000</td> <td>PIPE DIA 323.9X6.4 IS3589FE410 PA</td> <td style="text-align: center;">1700.00</td> <td style="text-align: center;">85.09</td> </tr> <tr> <td style="text-align: center;">4</td> <td style="text-align: center;">159385260000</td> <td>PIPE DIA 406.4 X 6.0 EFW IS3589 LS/SPIRAL</td> <td style="text-align: center;">3130.00</td> <td style="text-align: center;">185.42</td> </tr> </tbody> </table>	Item No.	Material Code	Item Description	Qty in Meters	Wt in MT	1	159385490000	PIPE DIA 219.1 X 6.0 IS3589-410MPA	1300.00	40.99	2	159385380000	PIPE DIA 273.1 X 6.0 IS3589-410MPA	350.00	13.83	3	159385390000	PIPE DIA 323.9X6.4 IS3589FE410 PA	1700.00	85.09	4	159385260000	PIPE DIA 406.4 X 6.0 EFW IS3589 LS/SPIRAL	3130.00	185.42
Item No.	Material Code	Item Description	Qty in Meters	Wt in MT																						
1	159385490000	PIPE DIA 219.1 X 6.0 IS3589-410MPA	1300.00	40.99																						
2	159385380000	PIPE DIA 273.1 X 6.0 IS3589-410MPA	350.00	13.83																						
3	159385390000	PIPE DIA 323.9X6.4 IS3589FE410 PA	1700.00	85.09																						
4	159385260000	PIPE DIA 406.4 X 6.0 EFW IS3589 LS/SPIRAL	3130.00	185.42																						
2	<p>TECHNICAL REQUIREMENT-</p> <p><u>A) PIPE REQUIREMENT</u></p> <p>i) Welded pipes conforming to IS 3589 Gr.410 shall be manufactured / fabricated (as applicable) and supplied meeting BHEL Technical Delivery Condition TDC: TDG:07 Rev. 08 dt 05.12.19.</p> <p>If Raw materials (Pipes) are received directly from RM Manufacturer's work meeting the requirements of TDC:TDG:07 Rev. 08 dt 05.12.19, the materials shall be accepted based on</p> <ol style="list-style-type: none"> a. Correlation of Heat Number on material with TCs b. Verification of TCs <p>If Raw materials (Pipes) are received from DEALERS meeting the requirements of TDC:TDG:07 Rev. 08 dt 05.12.19, Check test (Chemical and Mechanical tests on one sample per Heat / Size) shall be done at NABL approved Lab. This shall be made part of the Quality plan for approval by BHEL. BHEL shall identify the sample and witness the check test.</p> <p>ii) Pipe shall be supplied as per Drawing No. 3-80-477-36910-R00 (Refer production notes). Tolerance on total length of pipe given in Note: 02 is for manufacturing purpose only and Payment shall be made as per length mentioned in enquiry / PO or actual length supplied whichever is less.</p> <p>iii) Edge preparation shall be as per Drawing No 4-80-999-93079_Rev 00 (STYLE D).</p> <p>iv) WPS/PQR available with bidder shall be submitted.</p> <p>v) Typical Quality plan available with bidder shall be submitted.</p> <p>vi) Bidder shall submit detailed process flow chart from raw material stage including manufacturing of pipe (applicable for pipe manufacturers) / procurement of pipe from BHEL approved MAKES (applicable for fabricators), welding if any (to fabricate the required length), Edge Preparation, coating & testing.</p> <p>vii) Bidder shall submit valid ISO 9001:2015 certificate or Quality Management system Certificate or written down procedure.</p> <p>viii) Bidder shall comply to all requirements mentioned in TDC: TDG:07 Rev. 08 dt 05.12.19. In addition to the requirements in TDC: TDG:07 Rev. 08 dt 05.12.19, Cl 3.2 of TIP:07:0 dt 10.09.93 shall be followed for protection of EP. Material for the Metallic end cap shall be minimum 0.8mm thick of specification IS1079. Bidders are requested to submit drawing for the relevant end caps of tendered sizes for approval by BHEL along with Part-1 bid.</p> <p>ix) Submit duly filled in Unpriced bid enclosed (Annexure-A).</p> <p>x) Submit duly filled in Checklist enclosed along with supporting documents (Annexure-D).</p> <p>xi) Submit duly filled in Pre-Qualification Criteria (Annexure-F).</p> <p>xii) Bids qualifying the PQR conditions shall be evaluated for techno-commercial soundness. Only bids of techno-commercially qualified bidders shall be considered for price evaluation.</p>																									

ADDITIONAL TERMS & CONDITIONS FOR WELDED PIPES

Sl No	BHEL requirement
2	<p><u>B) COATING REQUIREMENT</u> Painting Scheme Reference for YADADRI QP NO: 7295: QPC: 12 Rev. 01 dt. 11.09.2018</p> <p><u>EXTERNAL COATING FOR OVERGROUND PIPE (OG) – All pipe sizes</u> Blast cleaning SSPC SP-10 SA 2 1/2 Epoxy based Zinc Phosphate to IS 13238 - 1 x 50 Microns Epoxy based MIO pigmented Intermediate coat – 2 x 75 Microns Epoxy based finish paint to IS 14209 – 1 x 25 Microns (Smoke grey shade no 692 of IS 5) Aliphatic Acrylic PU paint to IS 13213 – 1 x 25 Microns Total DFT 250 microns</p>
3	<p><u>DELIVERY PERIOD-</u> 90 DAYS from the date of Purchase order.</p>
4	<p><u>LIQUIDATED DAMAGES-</u> If the Seller/Service Provider fails to deliver any or all of the Goods/Services within the original/re-fixed delivery period(s) specified in the contract, the Buyer will be entitled to deduct/recover the Liquidated Damages for the delay, unless covered under Force Majeure conditions aforesaid, @ 0.5% of the contract value of delayed quantity per week or part of the week of delayed period as pre-estimated damages not exceeding 10% of the contract value of delayed quantity without any controversy/dispute of any sort whatsoever.</p>
5	<p><u>DELIVERY TERM-</u> 'FOR' Yadadri Project Site (all incl of P&F, F&I, testing, inspection charges etc).</p>
6	<p><u>EVALUATION & ORDERING-</u></p> <ol style="list-style-type: none"> 1. Evaluation of bids and ranking of bidders shall be done item wise. 2. Quoted rates shall be inclusive of GST. 3. Minimum Order Quantity (MOQ) / Minimum Order Value (MOV) condition will not be accepted. Bids of such bidders (if any) insisting for MOQ / MOV will be rejected.
7	<p><u>PREFERENCE TO MAKE IN INDIA PRODUCTS (FOR BIDS < 200 CRORE)-</u> Preference shall be given to Class 1 local supplier as defined in public procurement (Preference to Make in India), Order 2017 as amended from time to time and its subsequent Orders/Notifications issued by concerned Nodal Ministry for specific Goods/Products. The minimum local content to qualify as a Class 1 local supplier is denoted in the bid document. If the bidder (manufacturer) wants to avail the Purchase preference, the bidder must upload a certificate (as per Annexure-E) regarding the percentage of the local content and the details of locations at which the local value addition is made along with their bid, failing which no purchase preference shall be granted. In case the bid value is more than Rs 10 Crore, the declaration relating to percentage of local content shall be certified by the statutory auditor or cost auditor, if the OEM is a company and by a practicing cost accountant or a chartered accountant for OEMs other than companies as per the Public Procurement (preference to Make-in -India) order 2017 dated 04.06.2020.</p> <p>Only Class-I and Class-II Local suppliers as per MII order dated 4.6.2020 will be eligible to bid. Non - Local suppliers as per MII order dated 04.06.2020 are not eligible to participate. However, eligible micro and small enterprises will be allowed to participate. In case Buyer has selected Purchase preference to Micro and Small Enterprises clause in the bid, the same will get precedence over this clause.</p>

ADDITIONAL TERMS & CONDITIONS FOR WELDED PIPES

SI No	BHEL requirement
8	<p>PURCHASE PREFERENCE TO MICRO AND SMALL ENTERPRISES (MSES)- Purchase preference will be given to MSEs as defined in Public Procurement Policy for Micro and Small Enterprises (MSEs) Order, 2012 dated 23.03.2012 issued by Ministry of Micro, Small and Medium Enterprises and its subsequent Orders / Notifications issued by concerned Ministry. If the bidder wants to avail the Purchase preference, the bidder must be the manufacturer of the offered product in case of bid for supply of goods. Traders are excluded from the purview of Public Procurement Policy for Micro and Small Enterprises. Udyam Registration certification shall be submitted. If L-1 is not an MSE and MSE Seller (s) has/have quoted price within L-1+ 15% (Selected by Buyer) of margin of purchase preference / price band defined in relevant policy, such Seller shall be given opportunity to match L-1 price and contract will be awarded for 25% (selected by Buyer) percentage of total QUANTITY.</p>
9	<p>QUALITY PLAN After placement of Purchase order vendor shall submit Quality plan for fabrication of pipe, meeting the agreed tender requirements for review/approval immediately within 7 days from date of PO. Manufacturing / Fabrication shall commence subjected to approval of above QP by BHEL.</p>
10	<p>TESTING AND TEST CERTIFICATES Test certificates as called for in the TDC & approved QP shall be sent to Purchase / Piping Centre BHEL Chennai immediately after the shipment / dispatch of items. Inspection documents shall be furnished for each batch of dispatch / consignment. Soft copy in CD format of the all the test certificates shall also be submitted. Year of Code for the standards shall be latest and the specific year is to be mentioned in the Manufacturer's test certificates.</p>
11	<p>GUARANTEE- Bidders shall guarantee the supplies for a period of 24 months from the date of dispatch of materials or 18 months from the date of their commissioning whichever is earlier. To this effect a Guarantee certificate should be sent along with the dispatch documents in the event an order is placed on you. Material shall be guaranteed against manufacturing defects or faulty workmanship for a period of 24 months from the date of receipt of pipes with coating at project site. Any defect noticed during this period shall be repaired/replaced free of cost, to the satisfaction of BHEL and the End User. No deviation in this regard shall be accepted.</p>
12	<p>INSPECTION- Inspection shall be as per BHEL approved QP. Inspection will be done by BHEL / Authorized agency (Bureau Veritas India Pvt Ltd / TUV SUD). Inspection charges of BHEL / Their representative are to BHEL A/c. Any other testing charges should be included in the quoted prices. Inspection requirements and documents / certification shall be as per Cl 11 of TDC: TDG:07 Rev. 08 dt 05.12.19.</p> <ul style="list-style-type: none"> ➤ All facilities, equipment and instruments required for inspection shall be provided by the contractor free of cost. BHEL's Representatives will have free access to contractor's works during the currency of the contract. ➤ BHEL shall have general supervision and direction over the work. BHEL has the authority to stop the work, whenever such stoppage may be necessary to ensure the proper execution of the contract. BHEL shall also have the authority to reject all the work which does not conform to the specification. ➤ BHEL if required may test the finished sample per lot/size at NABL approved Lab at the bidder's cost
13	<p>QUALITY DOCUMENTS One original + two copies of Quality Documents, as called for in the quality plan/Purchase order shall be sent to Purchase / Piping centre BHEL Chennai immediately after the shipment / despatch of Items. All the quality documents are to be submitted in soft copy (in CD format) apart from the hard copy.</p>

ADDITIONAL TERMS & CONDITIONS FOR WELDED PIPES

SI No	BHEL requirement																	
14	<p><u>PAYMENT DOCUMENTS -</u></p> <p>Payment shall be made against presentation of following documents to our Finance Department. However, a copy of Invoice and LR shall be sent to Purchase department immediately after the dispatch is effected.</p> <p>a) Commercial Invoice in triplicate b) Delivery Challan in triplicate whichever is applicable c) Guarantee certificate d) Lorry Way Bill (Original + Two copies) e) Soft copy of Site Ack. Lorry Way Bill & Original Site Ack. Lorry Way Bill for regularising f) Quality documents (as per approved QP/PO)</p> <p>Soft copy of Invoice and LR should be sent immediately after dispatch by e-mail to Purchase. Hard copy should be sent subsequently within two weeks. Payment shall be processed only after receipt of soft copy of site acknowledgement. However preference in payment shall be given to MSE bidders as per MSMED Act 2006.</p>																	
15	<p><u>INTEGRITY PACT –</u> Format being sent. Your bid will be considered only after signing and submitting the Integrity pact.</p> <p>a) IP is a tool to ensure that activities and transactions between the Company and its Bidders / Contractors are handled in a fair, transparent and corruption free manner. Following Independent External Monitors (IEMs) on the present panel have been appointed by BHEL with the approval of CVC to oversee implementation of IP in BHEL.</p> <table style="width: 100%; border-collapse: collapse;"> <thead> <tr> <th style="text-align: left;">SI No</th> <th style="text-align: left;">IEM</th> <th style="text-align: left;">Email</th> </tr> </thead> <tbody> <tr> <td style="text-align: left;">1</td> <td style="text-align: left;">Shri Arun Chandra Verma, IPS (Retd.)</td> <td style="text-align: left;">acverma1@gmail.com</td> </tr> <tr> <td style="text-align: left;">2</td> <td style="text-align: left;">Shri Virendra Bahadur Singh, IPS (Retd.),</td> <td style="text-align: left;">vbsinghips@gmail.com</td> </tr> </tbody> </table> <p>b) The IP as enclosed with the tender is to be submitted (duly signed by authorized signatory) along with Techno-Commercial bid (Part-I, in case of two / three part bid). Only those bidders who have entered into such an IP with BHEL would be competent to participate in the bidding. In other words, entering into this Pact would be a preliminary qualification.</p> <p>c) Please refer Section-8 of IP for Role and Responsibilities of IEMs. In case of any complaint arising out of the tendering process, the matter may be referred to any of the above IEM(s). All correspondence with the IEMs shall be done through email only.</p> <p>Note: No routine correspondence shall be addressed to the IEM (phone / post / email) regarding the clarifications, time extensions or any other administrative queries, etc on the tender issued. All such clarification / issues shall be addressed directly to the tender issuing (procurement) department's officials whose contact details are provided below.</p> <table style="width: 100%; border-collapse: collapse;"> <tbody> <tr> <td style="width: 50%;">Ms. Poongkodi.V</td> <td style="width: 50%;">Mr. Venkataraman E</td> </tr> <tr> <td>Deputy Manager / Purchase</td> <td>DGM / Purchase</td> </tr> <tr> <td>Phone – 9488451450</td> <td>Phone – 8754666021</td> </tr> <tr> <td>Email: poongkodi@bhel.in</td> <td>Email: vram@bhel.in</td> </tr> </tbody> </table>	SI No	IEM	Email	1	Shri Arun Chandra Verma, IPS (Retd.)	acverma1@gmail.com	2	Shri Virendra Bahadur Singh, IPS (Retd.),	vbsinghips@gmail.com	Ms. Poongkodi.V	Mr. Venkataraman E	Deputy Manager / Purchase	DGM / Purchase	Phone – 9488451450	Phone – 8754666021	Email: poongkodi@bhel.in	Email: vram@bhel.in
SI No	IEM	Email																
1	Shri Arun Chandra Verma, IPS (Retd.)	acverma1@gmail.com																
2	Shri Virendra Bahadur Singh, IPS (Retd.),	vbsinghips@gmail.com																
Ms. Poongkodi.V	Mr. Venkataraman E																	
Deputy Manager / Purchase	DGM / Purchase																	
Phone – 9488451450	Phone – 8754666021																	
Email: poongkodi@bhel.in	Email: vram@bhel.in																	

UNPRICED BID – WELDED PIPES

Item No	Item Description	Qty in Meters	Weight in MT	Manufacturer / Fabricator	Quoted / Not Quoted
1	PIPE DIA 219.1 X 6.0 IS3589-410MPA	1300.00	40.99		
2	PIPE DIA 273.1 X 6.0 IS3589-410MPA	350.00	13.83		
3	PIPE DIA 323.9X6.4 IS3589FE410 PA	1700.00	85.09		
4	PIPE DIA 406.4 X 6.0 EFW IS3589 LS/SPIRAL	3130.00	185.42		

For Company Name:

Seal:

Signature:

Annexure-B
List of BHEL approved Paint sources

SL NO.	PAINT DESCRIPTION	BHEL VENDOR NAME
1	EPOXY BASED PAINTS & THINNERS	DOOALL CORPRO INDIA
2	EPOXY BASED PAINTS & THINNERS	GRAUER & WEIL (INDIA) LTD.,
3	EPOXY BASED PAINTS & THINNERS	POWER LIGHT PAINTS
4	EPOXY BASED PAINTS & THINNERS	CHEMECOAT PAINTS INDIA PVT LTD.
5	EPOXY BASED PAINTS & THINNERS	JOTUN INDIA PVT LTD
6	EPOXY BASED PAINTS & THINNERS	BERGER PAINTS INDIA LTD.,
7	EPOXY BASED PAINTS & THINNERS	GRAND POLYCOATS CO. PVT. LTD,
8	EPOXY BASED PAINTS & THINNERS	SYNORGANIC PAINTS PVT LTD
9	EPOXY BASED PAINTS & THINNERS	ADVANCE PAINTS PVT LTD.,
10	EPOXY BASED PAINTS & THINNERS	ASIAN PAINTS PPG PRIVATE LTD.
11	EPOXY BASED PAINTS & THINNERS	CARBOLINE INDIA PRIVATE LTD
12	EPOXY BASED PAINTS & THINNERS	WESTERN INDIA PAINT& COLOUR CO. (P)
13	EPOXY BASED PAINTS & THINNERS	NOVAA PAINTS
14	EPOXY BASED PAINTS & THINNERS	KANSAI NEROLAC PAINTS LIMITED,
15	EPOXY BASED PAINTS & THINNERS	SHEENLAC PAINTS LIMITED
1	EPOXY FINISH PAINTS	SYNORGANIC PAINTS PVT LTD
2	EPOXY FINISH PAINTS	CHEMECOAT PAINTS INDIA PVT LTD.
3	EPOXY FINISH PAINTS	SHEENLAC PAINTS LIMITED
4	EPOXY FINISH PAINTS	DOOALL CORPRO INDIA
5	EPOXY FINISH PAINTS	GRAUER & WEIL (INDIA) LTD.,
6	EPOXY FINISH PAINTS	POWER LIGHT PAINTS
7	EPOXY FINISH PAINTS	JOTUN INDIA PVT LTD
8	EPOXY FINISH PAINTS	GRAND POLYCOATS CO. PVT. LTD,
9	EPOXY FINISH PAINTS	ADVANCE PAINTS PVT LTD.,
10	EPOXY FINISH PAINTS	ASIAN PAINTS PPG PRIVATE LTD.
11	EPOXY FINISH PAINTS	WESTERN INDIA PAINT& COLOUR CO. (P)
12	EPOXY FINISH PAINTS	NOVAA PAINTS
13	EPOXY FINISH PAINTS	KANSAI NEROLAC PAINTS LIMITED,
14	EPOXY FINISH PAINTS	CARBOLINE INDIA PRIVATE LTD
15	EPOXY FINISH PAINTS	BERGER PAINTS INDIA LTD.,

Annexure- C

List of approved RM sources for IS3589 pipes up to NB400

Sl. No.	BHEL APPROVED IS3589 PIPE SOURCE	LOCATION	APPROVED RANGE
1	ASIAN MILLS PVT LTD	AHMEDABAD	UPTO NB400
2	GAJANAN TUBES PVT LTD	KOLKATA	UPTO NB300
3	GAURANG PRODUCTS PVT LTD	GHAZIABAD.	UPTO NB400
4	GOODLUCK INDIA LIMITED	GHAZIABAD	UPTO NB250
5	INDUS TUBES LTD	NEW DELHI	UPTO NB250
6	JINDAL SAW LTD.,	NEW DELHI.	UPTO NB400
7	MKK METAL SECTIONS PVT LTD	RANIPET	UPTO NB350
8	MUKAT TANKS AND VESSELS PVT LTD	MUMBAI.	UPTO NB400
9	RATNAMANI METALS & TUBES LTD.,	AHEMEDABAD	UPTO NB400
10	RIDDHI STEEL & TUBES (P) LTD	AHMEDABAD.	UPTO NB200
11	SG HEAVY ENGINEERING PVT LTD	PALGHAR.	UPTO NB400
12	SURYA ROSHNI LTD	BAHADUR GARH	UPTO NB400
13	SWASTIK PIPES LIMITED,	NEW DELHI	UPTO NB400

CHECK LIST**NOTE: - Tenderers are required to fill in the following details and no column should be left blank**

1	Name and Address of the Tenderer		
2	Details about type of the Firm/Company	Proprietorship / Partnership / Private / Others	
3.a	Details of Contact person for this Tender	Name : Mr/Ms Designation: Telephone No: Mobile No: Email ID: Fax No:	
3.b	Details of alternate Contact person for this Tender	Name : Mr/Ms Designation: Telephone No: Mobile No: Email ID: Fax No:	
		APPLICABILITY (BY BHEL)	ENCLOSED / AGREED BY BIDDER
4	Whether the format for compliance with PRE QUALIFICATION CRITERIA is understood and filled with proper supporting documents referenced in the specified format	Applicable	YES / NO
5	Audited Balance sheet, Profit and Loss Account for the last three years	Applicable	YES/NO
6	Copy of PAN Card & GST Registration Certificate	Applicable	YES/NO
7	Whether all pages of the Tender documents including annexures, appendices etc. are read and understood	Applicable	YES/NO
8	Bank Account Details for E-Payment	Applicable	YES/NO
9	Whether agreed to procure RM pipes from BHEL approved sources mentioned in Annexure-C	Applicable for fabricators only	YES/NO
10	Whether agreed to use Paint brands from BHEL approved sources mentioned in Annexure-B	Applicable	YES/NO

NOTE: STRIKE OFF 'YES' OR 'NO', AS APPLICABLE. TENDER NOT ACCOMPANIED BY THE PRESCRIBED **ABOVE APPLICABLE DOCUMENTS** ARE LIABLE FOR REJECTION.

DATE:**AUTHORISED SIGNATORY**

(With Name, Designation and Company seal)

Declaration format for Make in India to be issued on Bidder's Company letter head

Self-Declaration

Enquiry No.	
Enquiry Date	

In line with Government public procurement order Number P45021/2/2017-B.E-II dated 15.06.2017, and further modified order dt. 28.05.2018 & order 04.06.2020 issued by DPIIT

I / We hereby declare that I / We are a "Local Supplier" meeting the requirement of minimum local content (.....%) defined in the above government notification for the goods against above mentioned enquiry Number.

Details of location at which local value addition will be made is as follows:

Door No.	
Street / Address 1	
Street / Address 2	
District	
State	
Country	
PIN Code	

We also understand that the false declarations will be considered as breach of Integrity and liable for action.

For Company Name:

Seal:

Signature:

Date:

Place:

(Please fill all the yellow colour fields)

INTEGRITY PACT

Between

Bharat Heavy Electricals Ltd. (BHEL), a company registered under the Companies Act 1956 and having its registered office at "BHEL House", Siri Fort, New Delhi - 110049 (India) hereinafter referred to as "The Principal", which expression unless repugnant to the context or meaning hereof shall include its successors or assigns of the ONE PART

and

_____, (description of the party along with address), hereinafter referred to as "The Bidder/ Contractor" which expression unless repugnant to the context or meaning hereof shall include its successors or assigns of the OTHER PART

Preamble

The Principal intends to award, under laid-down organizational procedures, contract/s for ENQUIRY REFERENCE GEM/2021/B/1750399 DT 10.12.2021 - SUPPLY OF WELDED PIPES TO YADADRI PROJECT SITE

_____. The Principal values full compliance with all relevant laws of the land, rules and regulations, and the principles of economic use of resources, and of fairness and transparency in its relations with its Bidder(s)/ Contractor(s).

In order to achieve these goals, the Principal will appoint Independent External Monitor(s), who will monitor the tender process and the execution of the contract for compliance with the principles mentioned above.

Section 1- Commitments of the Principal

1.1 The Principal commits itself to take all measures necessary to prevent corruption and to observe the following principles:-

1.1.1 No employee of the Principal, personally or through family members, will in connection with the tender for, or the execution of a contract, demand, take a promise for or accept, for self or third person, any material or immaterial benefit which the person is not legally entitled to.

1.1.2 The Principal will, during the tender process treat all Bidder(s) with equity and reason. The Principal will in particular, before and during the tender process, provide to all Bidder(s) the same information and will not provide to any Bidder(s) confidential/ additional information through which the Bidder(s) could obtain an advantage in relation to the tender process or the contract execution.

1.1.3 The Principal will exclude from the process all known prejudiced persons.

1.2 If the Principal obtains information on the conduct of any of its employees which is a penal offence under the Indian Penal Code 1860 and Prevention of Corruption Act 1988 or any other statutory penal enactment, or if there be a substantive suspicion in this regard, the Principal will inform its Vigilance Office and in addition can initiate disciplinary actions.

Section 2 - Commitments of the Bidder(s)/ Contractor(s)

- 2.1 The Bidder(s)/ Contractor(s) commit himself to take all measures necessary to prevent corruption. He commits himself to observe the following principles during his participation in the tender process and during the contract execution.
- 2.1.1 The Bidder(s)/ Contractor(s) will not, directly or through any other person or firm, offer, promise or give to the Principal or to any of the Principal's employees involved in the tender process or the execution of the contract or to any third person any material, immaterial or any other benefit which he/ she is not legally entitled to, in order to obtain in exchange any advantage of any kind whatsoever during the tender process or during the execution of the contract.
- 2.1.2 The Bidder(s)/ Contractor(s) will not enter with other Bidder(s) into any illegal or undisclosed agreement or understanding, whether formal or informal. This applies in particular to prices, specifications, certifications, subsidiary contracts, submission or non-submission of bids or any other actions to restrict competitiveness or to introduce cartelization in the bidding process.
- 2.1.3 The Bidder(s)/ Contractor(s) will not commit any penal offence under the relevant Indian Penal Code (IPC) and Prevention of Corruption Act; further the Bidder(s)/ Contractor(s) will not use improperly, for purposes of competition or personal gain, or pass on to others, any information or document provided by the Principal as part of the business relationship, regarding plans, technical proposals and business details, including information contained or transmitted electronically.
- 2.1.4 Foreign Bidder(s)/ Contractor(s) shall disclose the name and address of agents and representatives in India and Indian Bidder(s)/ Contractor(s) to disclose their foreign principals or associates. The Bidder(s)/ Contractor(s) will, when presenting his bid, disclose any and all payments he has made, and is committed to or intends to make to agents, brokers or any other intermediaries in connection with the award of the contract.
- 2.2 The Bidder(s)/ Contractor(s) will not instigate third persons to commit offences outlined above or be an accessory to such offences.
- 2.3 The Bidder(s)/ Contractor(s) shall not approach the Courts while representing the matters to IEMs and will await their decision in the matter.

Section 3 - Disqualification from tender process and exclusion from future contracts

If the Bidder(s)/ Contractor(s), before award or during execution has committed a transgression through a violation of Section 2 above, or acts in any other manner such as to put his reliability or credibility in question, the Principal is entitled to disqualify the Bidder(s)/ Contractor(s) from the tender process or take action as per the separate "Guidelines on Banning of Business dealings with Suppliers/ Contractors", framed by the Principal.

Section 4 - Compensation for Damages

- 4.1 If the Principal has disqualified the Bidder from the tender process prior to the award according to Section 3, the Principal is entitled to demand and recover the damages equivalent Earnest Money Deposit/ Bid Security.
- 4.2 If the Principal has terminated the contract according to Section 3, or if the Principal is entitled to terminate the contract according to section 3, the Principal shall be entitled to

demand and recover from the Contractor liquidated damages equivalent to 5% of the contract value or the amount equivalent to Security Deposit/ Performance Bank Guarantee, whichever is higher.

Section 5 - Previous Transgression

- 5.1 The Bidder declares that no previous transgressions occurred in the last 3 years with any other company in any country conforming to the anti-corruption approach or with any other Public Sector Enterprise in India that could justify his exclusion from the tender process.
- 5.2 If the Bidder makes incorrect statement on this subject, he can be disqualified from the tender process or the contract, if already awarded, can be terminated for such reason.

Section 6 - Equal treatment of all Bidders/ Contractors / Sub-contractors

- 6.1 The Principal will enter into agreements with identical conditions as this one with all Bidders and Contractors. In case of sub-contracting, the Principal contractor shall be responsible for the adoption of IP by his sub-contractors and shall continue to remain responsible for any default by his sub-contractors.
- 6.2 The Principal will disqualify from the tender process all bidders who do not sign this pact or violate its provisions.

Section 7 - Criminal Charges against violating Bidders/ Contractors /Subcontractors

If the Principal obtains knowledge of conduct of a Bidder, Contractor or Subcontractor, or of an employee or a representative or an associate of a Bidder, Contractor or Subcontractor which constitutes corruption, or if the Principal has substantive suspicion in this regard, the Principal will inform the Vigilance Office.

Section 8 -Independent External Monitor(s)

- 8.1 The Principal appoints competent and credible Independent External Monitor for this Pact. The task of the Monitor is to review independently and objectively, whether and to what extent the parties comply with the obligations under this agreement.
- 8.2 The Monitor is not subject to instructions by the representatives of the parties and performs his functions neutrally and independently. He reports to the CMD, BHEL.
- 8.3 The Bidder(s)/ Contractor(s) accepts that the Monitor has the right to access without restriction to all contract documentation of the Principal including that provided by the Bidder(s)/ Contractor(s). The Bidder(s)/ Contractor(s) will grant the monitor, upon his request and demonstration of a valid interest, unrestricted and unconditional access to his contract documentation. The same is applicable to Sub-contractor(s). The Monitor is under contractual obligation to treat the information and documents of the Bidder(s)/ Contractor(s) / Sub-contractor(s) with confidentiality in line with Non- disclosure agreement.
- 8.4 The Principal will provide to the Monitor sufficient information about all meetings among the parties related to the contract provided such meetings could have an impact on the contractual relations between the Principal and the Contractor. The parties offer to the Monitor the option to participate in such meetings.
- 8.5 The role of IEMs is advisory, would not be legally binding and it is restricted to resolving issues raised by an intending bidder regarding any aspect of the tender which allegedly

restricts competition or bias towards some bidders. At the same time, it must be understood that IEMs are not consultants to the Management. Their role is independent in nature and the advice once tendered would not be subject to review at the request of the organization.

- 8.6 For ensuring the desired transparency and objectivity in dealing with the complaints arising out of any tendering process, the matter should be examined by the full panel of IEMs jointly as far as possible, who would look into the records, conduct an investigation, and submit their joint recommendations to the Management.
- 8.7 The IEMs would examine all complaints received by them and give their recommendations/ views to CMD, BHEL, at the earliest. They may also send their report directly to the CVO and the Commission, in case of suspicion of serious irregularities requiring legal/ administrative action. IEMs will tender their advice on the complaints within 10 days as far as possible.
- 8.8 The CMD, BHEL shall decide the compensation to be paid to the Monitor and its terms and conditions.
- 8.9 IEM should examine the process integrity, they are not expected to concern themselves with fixing of responsibility of officers. Complaints alleging mala fide on the part of any officer of the organization should be looked into by the CVO of the concerned organisation.
- 8.10 If the Monitor has reported to the CMD, BHEL, a substantiated suspicion of an offence under relevant Indian Penal Code/ Prevention of Corruption Act, and the CMD, BHEL has not, within reasonable time, taken visible action to proceed against such offence or reported it to the Vigilance Office, the Monitor may also transmit this information directly to the Central Vigilance Commissioner, Government of India.
- 8.11 The number of Independent External Monitor(s) shall be decided by the CMD, BHEL.
- 8.12 The word 'Monitor' would include both singular and plural.

Section 9 - Pact Duration

- 9.1 This Pact shall be operative from the date IP is signed by both the parties till the final completion of contract for successful bidder and for all other bidders 6 months after the contract has been awarded. Issues like warranty / guarantee etc. should be outside the purview of IEMs.
- 9.2 If any claim is made/ lodged during currency of IP, the same shall be binding and continue to be valid despite the lapse of this pact as specified above, unless it is discharged/ determined by the CMD, BHEL.

Section 10 - Other Provisions

- 10.1 This agreement is subject to Indian Laws and jurisdiction shall be registered office of the Principal, i.e. New Delhi.
- 10.2 Changes and supplements as well as termination notices need to be made in writing. Side agreements have not been made.

10.3 If the Contractor is a partnership or a consortium, this agreement must be signed by all partners or consortium members.

10.4 Should one or several provisions of this agreement turn out to be invalid, the remainder of this agreement remains valid. In this case, the parties will strive to come to an agreement to their original intentions.

10.5 Only those bidders / contractors who have entered into this agreement with the Principal would be competent to participate in the bidding. In other words, entering into this agreement would be a preliminary qualification.

POONGKODI V Digitally signed by POONGKODI V
Date: 2021.12.10 11:44:49 +05'30'

For & On behalf of the Principal

(Office Seal)

For & On behalf of the Bidder/

Contractor

(Office Seal)

Place-CHENNAI-----

Date-10.12.2021-----

Witness: **GANESAN**
VINOTH Digitally signed by GANESAN
VINOTH
Date: 2021.12.10 11:53:19
+05'30'

(Name & Address) _____

Witness: _____

(Name & Address) _____

ENQUIRY REF GEM/2021/B/1750399

PRE – QUALIFICATION REQUIREMENT (PQR) FOR SUPPLY OF IS-3589 PIPES

Annexure-F

SI No.	PQR Description	Documents to be submitted	** Bidder response (Submitted / Not submitted)
1	<p>Bidder shall be Manufacturer OR Fabricator OR Authorized agent of the manufacturer.</p> <p>However, agents submitting bid on behalf of original manufacturer / supplier shall not represent more than one manufacturer / supplier in the same Tender. In case bids are received from both – the manufacturer / supplier and the agent, the Bid by the agent shall be ignored.</p> <p>Bids from traders, distributors and stockists are not acceptable and will not be considered for evaluation.</p>	<p>1) Any Proof Certificate for being a manufacturer or Fabricator viz Certificate of Registration / Factory license etc</p> <p>2) In case of Agent, Agency Agreement with Manufacturer</p>	
2	<p><u>ORGANIZATIONAL CAPABILITY:</u></p> <p>Bidder shall have necessary facilities for manufacturing / fabrication, testing (in-house or outsourced), handling, space for storage & coating.</p> <p>Requisite personnel to fabricate the tendered items as per the Drawing and Technical requirements.</p>	<p>List of manufacturing / fabrication, testing (in-house or outsourced) & handling facilities, storage area available and list of personnel at registered factory address shall be furnished.</p>	
3	<p><u>EXPERIENCE CRITERIA:</u></p> <p>Bidder shall have prior experience in supply of IS 3589 Pipes.</p> <p>Minimum size of experience shall be NB200. Supply experience being furnished shall not be prior to 4 years from the date of the Enquiry.</p> <p>Supply Experience POST part-1 bid opening date shall not be considered.</p>	<p>Reference list containing Customer name, PO ref, PO Date, Size & Quantity, Month and year of their supplies to be furnished.</p> <p>Latest PO copies along with Proof of Supply completion shall be furnished.</p> <p>End customer details shall be provided to verify the performance, if required.</p>	

ENQUIRY REF GEM/2021/B/1750399

PRE – QUALIFICATION REQUIREMENT (PQR) FOR SUPPLY OF IS-3589 PIPES

Annexure-F

SI No.	PQR Description	Documents to be submitted	** Bidder response (Submitted / Not submitted)
4	<p><u>FINANCIAL SOUNDNESS:</u> Bidder should have made a turnover of at least Rs. 93 lakhs for anyone of last 4 audited Financial Years (FYs 2020-21, 2019-20, 2018-19, 2017-18). Start-up which has commenced operations only in the current Financial year (FY 2021-22) but meeting financial turnover criteria shall submit certificate from CA certifying the turnover made up to the current month of FY (FY 2021-22).</p>	<p>Audited Balance Sheet and Audited Profit & Loss Account for the past four financial years (FYs 2020-21, 2019-20, 2018-19, 2017-18). In case bidders have commenced operations within the past 4 years from the date of enquiry, audited Balance Sheet and P&L statement for the available years shall be submitted.</p>	

**** Supporting documents to be enclosed without fail.**

Note –

1. Bids fulfilling the above criteria will be considered for further techno-commercial evaluation.
2. For Startups and MSE bidders, Annual Financial Turnover criteria (Sl. No: 4 above) is relaxed by 50% (Rs. 46.5 lakhs), during anyone of the Financial years in the past 4 years and prior experience criteria (Sl. No: 3 above) is relaxed to last 5 years from the date of Enquiry.
Relaxation is subject to bidder meeting technical and quality criteria of the PQR. Bidders proposing to avail relaxation as above need to submit necessary document proof along with Pre-Qualification bid.
 - a) Startups - Certificate of Recognition by Department of Industrial Policy & Promotion
 - b) MSE – Udyam Registration certificate
3. Bidder to submit all supporting documents in English language. If documents submitted by bidder are in a language other than English, a self-attested English translated document shall also be submitted.
4. Bidders referred to NCLT, NCLAT or firms having strictures / hold by any other Government agency will not be considered.

For Company Name:

Seal:

Signature:

3-80-477-36910
DRAWING NO.

NOTES: -

- 01 ALL PIPES ARE TO BE SUPPLIED WITH EDGE PREPARATION AS PER DRG NO. 4-80-999-93079. FOR EP STYLE & WELD END DIA ($\phi d1$), REFER THE TABLE. INSIDE BEVEL IS REQUIRED, ONLY IF D1 VALUE IS HIGHER THAN INSIDE DIAMETER.
- 02 TOLERANCE ON TOTAL LENGTH OF PIPE IS ± 2 METERS, IF TOTAL LENGTH IS $>350M$. OTHERWISE TOLERANCE ON TOTAL LENGTH OF PIPE IS $\pm 0.5M$.
- 03 FOR SHOP PAINTING/COATING DETAILS, REFER CUSTOMER APPROVED PAINTING SCHEDULE & QUALITY PLAN FOR THE PROJECT.
- 04 FOR PIPE DIAMETER $> 1000mm$, SPIDER ARRANGEMENT HAS TO BE PROVIDED AT THE ENDS AFTER EDGE PREPARATION, AS PER DRG. NO. 4-80-999-93078. FOR PIPE DIAMETER $< 1000mm$, SPIDER ARRANGEMENT IS NOT REQUIRED.



SL. No.	DU NO.	PGMA	PIPE DESCRIPTION	QTY (in Meters)	SPECIFIC LENGTH	MATL. CODE	EDGE PREPARATION AS PER DRG NO. 4-80-999-93079		CUST NO.	SYSTEM DESCRIPTION
						MATL. SPEC.	STYLE	$\phi d1$		
01	093	80-477	PIPE OD406.4x6 (OVER GROUND PIPING)	3130	06 m TO 14 m	15 938 526 0000 IS3589-410MPA	STYLE-D	394.4	7300	PLANT WATER & SERVICE WATER
02	094	80-477	PIPE OD323.9x6.4 (OVER GROUND PIPING)	1700	06 m TO 14 m	15 938 539 0000 IS3589-410MPA	STYLE-D	311.1	7300	PLANT WATER & SERVICE WATER
03	095	80-477	PIPE OD273.1x6 (OVER GROUND PIPING)	350	06 m TO 14 m	15 938 538 0000 IS3589-410MPA	STYLE-D	261.0	7300	PLANT WATER & SERVICE WATER
04	096	80-477	PIPE OD219.1x6 (OVER GROUND PIPING)	1300	06 m TO 14 m	15 938 549 0000 IS3589-410MPA	STYLE-D	207.0	7300	PLANT WATER & SERVICE WATER

CUSTOMER NO. : 7300									
NAME OF PROJECT : YADADRI TPS 5X800MW									
NAME OF CUSTOMER : TELANGANA STATE POWER GENERATION CO. LTD.									
	BHARAT HEAVY ELECTRICALS LTD.,		DRN	NAME	SIGN	DATE	NO OF ITEMS		
	PIPING CENTRE, MADRAS		CHD	TRINADHA RAO		29.11.21			
			APPD	VENKAT		29.11.21			
REV 01	DATE	ALTERED APPROVED	DEPT.	GRADE OF UN TOL DIM		SCALE	WEIGHT (Kg)	NAME OF ORIGINAL ORGANISATION	ITEM No.
ZONE			CODE	C/M/F		N.T.S			
TITLE PRODUCTION NOTES FOR LP PIPING SYSTEM							CARD CODE U 01	DRAWING No. 3-80-477-36910	REV 00

CAUTION: The information on this document is the property of BHARAT HEAVY ELECTRICALS LTD. It must not be used directly or indirectly in any way detrimental to the interest of the company

CAUTION: The information on this document is the property of BHARAT HEAVY ELECTRICALS LTD. It must not be used directly or indirectly in any way detrimental to the interest of the company.

REV	DATE	ALTERED	ALL DIMENSIONS ARE IN MILLIMETRES
		APPROVED	

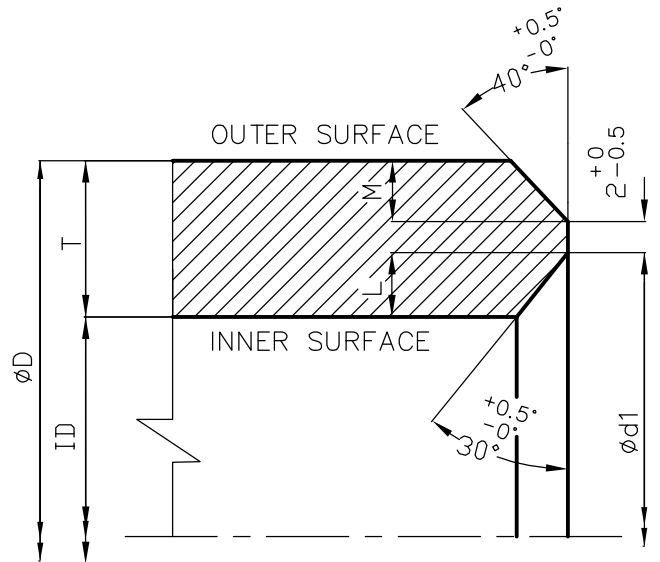

PIPE SIZE	M	L	ID	$\phi d1$
$\phi D \times T$	5	T-7	D-2T	D-14

FIG-A E.P.DETAIL FOR PIPES OF THICKNESS ABOVE 14mm

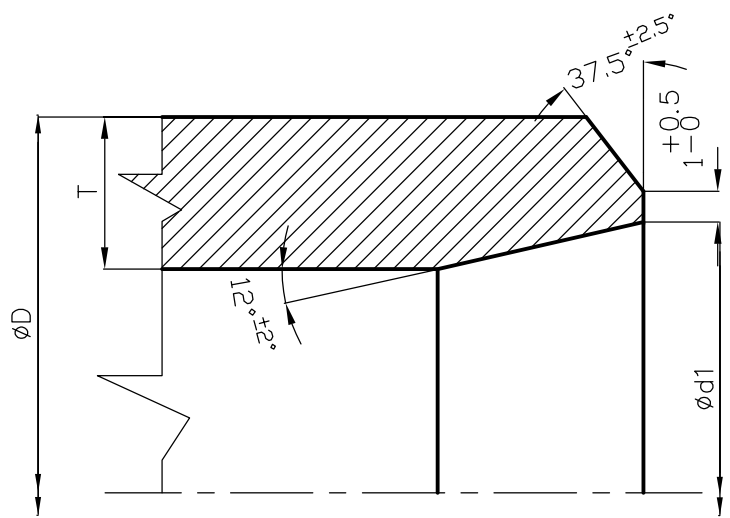

PIPE SIZE	$\phi d1$
$\phi D \times T$	D-2T

STYLE-D E.P.DETAIL FOR PIPES OF THICKNESS 14mm AND BELOW

STANDARD

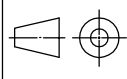
 BHARAT HEAVY ELECTRICALS LIMITED PIPING CENTRE CHENNAI 600 017	DRN	NAME	SIGN	DATE	NO. OF VAR		
	CHD	C.K.KARAN		11.04.08			
	APPD	C.K.KARAN		11.04.08			
DEPT	GRADE OF UNTOL. DIM		SCALE	WEIGHT (KG).	REF. TO ASSY./OLD DRG.	ITEM NO.	NO. OF ITEMS
CODE	C / M / F		N.T.S				
TITLE			CARD CODE	DRAWING NO.	REV		
EDGE PREPARATION DETAIL FOR PIPE DIA > 1000			U 01	4-80-999-93079	00		

**TELANGANA STATE POWER GENERATION CORPORATION LIMITED**

(A Govt. Of Telangana Undertaking)

VidyutSoudha, Hyderabad - 500082.

Phone: 040 - 23499261

Fax: 040 - 23499263

From:

The Chief Engineer,
Thermal Projects Construction,
TSGENCO, 3rd Floor, A-Block,
VidyutSoudha, Khairathabad
Hyderabad-500 082. cetpctgenco@gmail.com

To:

M/s Bharat Heavy Electricals Limited,
Piping Centre, #80, G.N. Chetty Road,
T.Nagar, Chennai - 600 017
Phone: 9500127314
Email ID: vishnujyoti@bhel.in

Kind Attention: Mrs. Vishnu Jyoti G.V.V, Deputy Manager/Comml

Lr.No.CE/TPC/SE-3/EME-14/YTPS/Painting Scheme/D.No.127/18,Dt:20.09.2018

Sir,

Sub:- TSGENCO-YTPS(5x800 MW) -PAINTING SCHEME FOR LP PIPING furnished by M/s BHEL/PC-Chennai - Approval - Reg.

Ref:- 1)M/s BHEL Ref:QP No. 7295:QPC:12,REV.No. 01 Dt: 11.09.2018.
2)M/s TCE e-Mail dated:17.09.2018.

Please refer to the letter 1st cited above, wherein M/s BHEL/PC-Chennai has submitted the revised Painting Scheme for LP piping pertaining to Yadadri TPS (5x800 MW) for review & approval.

The above Painting Scheme for LP Piping furnished by M/s BHEL/PC-Chennai is herewith reviewed and approved. An approved copy is herewith enclosed for taking further necessary action at your end.

It is requested to upload the above Painting Scheme for LP Piping in PEDM Portal.

Encl: As above

Yours faithfully,

Chief Engineer/TPC

Copy Communicated to:

- 1) Chief Engineer/Construction/YTPS Site/Damaracherla/Nalgonda Dist.
- 2) Sri Y.A.Srinivas Rao, BHEL/PMG Camp Office, Vidyut Soudha, Hyderabad.
- 3) DE/Tech to Director/Projects/TSGENCO/VS/Hyderabad.
- 4) M/s Tata Consulting Engineers Limited, 73/1, Sheriff Centre, St. Marks road, Bangalore-560 001.
- 5) M/s TCE /Room No.323 /Site Office/VidyutSoudha/Hyderabad



BHARAT HEAVY ELECTRICALS LIMITED
 PIPING CENTRE, CHENNAI- 17
 QUALITY ASSURANCE & CONTROL DEPT.

PAINTING SCHEME FOR LP PIPING

(CW / ACW / ECW / Plant water, Air Piping, etc...,)

PROJECT NAME : - YADADRI TPS - 5X800 MW
 BHEL CUSTOMER Nos : 7295,7296,7297,7298,7299,7300&7306

QPNo: 7295:QPC:12

REV.NO: 01

Dt : 11.09.2018

Sl. NO	PGMA / Description	Surface Preparation & Surface Profile	Primer coat		Intermediate coat			Finish coat			Total DFT Microns (Min.)	REMARKS	
			Primer	No of coats	Paint	No of coats	Shade	Paint	No of coats	Shade			
1	2	3	4	5	6	7	8	9	10	11	12	13	
1	(a) Internal Surface - CW Pipe (for pipe - dia - 1000 mm and above)	Blast Cleaning SSPC SP-10 SA 2½ (Refer Note 1)	Two part Epoxy Primer	1 (50 Microns Min. per coat)	Two part Polyamide cured solvent less Epoxy (100% solids)			300-350 Microns Min.		---	350-400 Microns	Refer Note 1&2	
	(b) Holiday test (Refer Note 3)	Holiday testing by low voltage (75 Volts Min.) wet sponge Holiday detector or by High voltage (Voltage per micron of DFT is as recommended by Paint Manufacturer subjected to minimum of 5V / Micron). Holiday test Equipment to be calibrated before testing.											
2	External Surface of CW --Buried Piping / Encased in concrete (Temporary Protection for transportation from works to site).	SSPC-SP3 / Power Tool Cleaning	Red Oxide Zinc Phosphate (Alkyd base to IS 12744)	1 (30 Microns per coat)	Further protection to be done by BHEL Erection Group as per Contract requirement (Rapping coating conforming to AWWA-C-203/IS15337)								
3	External Surface (over ground piping) of CW,ACW.(For all diameters)	Blast Cleaning SSPC SP-10 SA 2½	Epoxy based Zinc Phosphate to IS: 13238	1 (50 Microns per coat)	Epoxy Based MIO Pigmented Intermediate Coat.	2 (DFT=75 Micron Min Per coat)	---	Epoxy based finish paint to IS: 14209 + Aliphatic Acrylic PU Paint to IS: 13213	1 (25 microns per coat) + 1 (25 microns per coat)	Smoke Grey (Shade No. 692 of IS: 5)	250		
4	External Surface of ECW, Plant water (For all diameters)	Blast Cleaning SSPC SP-10 SA 2½	Epoxy based Zinc Phosphate to IS: 13238	1 (50 Microns per coat)	Epoxy Based MIO Pigmented Intermediate Coat.	2 (DFT=75 Micron Min Per coat)	---	Epoxy based finish paint to IS: 14209 + Aliphatic Acrylic PU Paint to IS: 13213	1 (25 microns per coat) + 1 (25 microns per coat)	Smoke Grey (Shade No. 692 of IS: 5)	250		
5	Galvanised and Stainless steel Piping	No painting											

Notes:

1. Blast cleaning & application of Polyamide cured solvent less Epoxy (100% solids) shall be done as per manufacturer's data sheet / recommendation, meeting the thickness requirements as per this document.
2. Witness by BHEL / BHEL nominated inspection agency.

<i>J. Nanthini</i>	<i>Vivekananda Yellu</i>	For Customer use :
PREPARED BY : J NANTHINI, Sr.Engr / QA	APPROVED BY : VIVEKANANDA YELLU, Dy.MGR / QA	

V. Srinivas
 Chief Engineer
 Thermal Projects Construction
 TSGENCO, Vidyut Soudha,
 Khairatabad, Hyd-500 082.



Bharat Heavy Electricals Limited, Piping Centre, Chennai

**Technical Delivery Conditions for IS 3589 Pipes /
Rolled & Welded Pipes using IS2062 plates or IS 10748
coils, confirming to IS 3589.**

Doc: TDG : 07
Rev : 08
Dt : 05.12.2019
Page 1 of 3

Records of Revn:07 :- Applicable Pipe Size indicated in para 1.3; *Para 2.0, 8.3 & 9.1 revised.
Para 4.4, 5.0 & 10.0 added further clauses re-numbered;*

Records of Revn:08 :- Modified based on Internal Discussion regarding BIS license
requirement dt 28.11.2019.

1.0 SCOPE

- 1.1 This Technical Delivery Conditions specify the requirements in addition to IS:3589 for electrically welded (ERW \ SAW) steel pipes.
- 1.2 The pipes are intended for water, air services (under Non-IBR Piping system only).
- 1.3 The pipes shall conform to the size, grade and quantity as specified in the purchase order.

Applicability: Pipe outside Diameter from 168.30mm to 2540.00mm.

2.0 RAW MATERIAL

Raw material (IS 2062 plates / IS 10748 coils) used for pipe shall meet the requirements as per IS: 3589 Grade Fe 410 MPa including Chemical (Ladle analysis) & Mechanical test requirements.

3.0 DIMENSIONAL TOLERANCES



- 3.1 The tolerances limits are:
- a) OD:- Upto NB 1600 mm: ± 4 mm; Above NB 1600 mm: ± 6 mm
 - b) Thickness:- Upto 14mm : +1.3mm / -0.8mm; Above 14 mm : +1.4mm / - 0.8mm.
 - c) Ovality (Difference between major and minor inside diameter): 0.5% maximum
 - d) Squareness of ends: The ends of pipe section shall not vary by more than 3mm at any point from a true plane perpendicular to the axis of the pipe and passing through the center of the pipe at the end.
 - e) Length and quantity tolerance as per P.O.
- 3.2 Other tolerances shall be as per IS: 3589

4.0 MANUFACTURING

- 4.1 The pipe shall be of longitudinally welded or spirally welded as indicated in the Tender/P.O.
- 4.2 The ends shall be edge prepared as indicated in the Tender/P.O.
- 4.3 Circumferential seams shall be minimum 1500 mm apart from each other and from ends.
- 4.4 For longitudinal SAW pipes the offset between any two subsequent longitudinal joints shall be more than 90deg.
- 4.5 All pipes shall be completely finished and free from surface, sub surface defects such as pits, cracks, weld spatters & laminations etc..

5.0 CHEMICAL & MECHANICAL TEST

- 5.1 **Product Analysis:-** Shall be done for One sample per heat per size as per IS3589. Chemical values shall meet the IS3589 table - 2 & 3 requirements.
- 5.2 **Mechanical Tests:-**
- (a) **Tensile test for ERW / SAW Pipes:** Shall be done for One sample per heat per size as per IS3589. Values shall meet the IS3589 table - 4 requirements.

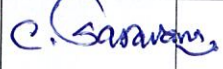
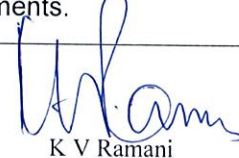
 J Nanthini Dy.Mgr/QA	 D Sandra Priya Dy.Mgr/QA	 K. Rajitha AGM/MM	 C Saravanan SDGM/Engg	 K V Ramani AGM/Engg & Quality
Prepared By	Reviewed By			Approved By



**Technical Delivery Conditions for IS 3589 Pipes /
Rolled & Welded Pipes using IS2062 plates or IS 10748
coils, confirming to IS 3589.**

(b) **Flattening test for ERW Pipes:** Shall be done for One sample per heat per size as per IS3589 and shall confirm to para 9.2.1 of IS3589.

(c) **Guided Bend test for SAW Pipes:** Shall be done for One sample per heat per size as per IS3589 and shall confirm to para 9.3.2 & 9.3.3 of IS3589.

6.0 NDE

6.1 For Pipe dia less than 1000mm:- 100 % Hydro test on each pipe + Radiography test for 100mm weld length at both the ends for 10% of the pipes.

6.2 For Pipe dia 1000 mm & above :-The NDT for each pipe shall be done by any one of the following options. The vendor shall indicate their choice in the offer.

a) 100 % Hydro test + Radiography test for 100mm weld length on both the ends of each pipe.

b) 100 % Ultrasonic test + 10 % Radiography test on weld length (including all T-joints and 100mm weld length at both the ends) for each pipe.

c) 100 % Radiography test on complete weld length of each pipe.

6.3 The Ultrasonic test / Radiography test shall be carried out as per ASME Sec-V and shall be accepted as per ASME B31.1 Cl:136.4.6 / Cl:136.4.5.

7.0 INSPECTION

7.1 All pipes shall be inspected by the vendor prior to BHEL / Customers' Inspection. BHEL or BHEL authorized inspector / Customer will select the pipes at random and carryout the inspection. The necessary Material Despatch Clearance Certificate is to be obtained by the vendor prior to the despatch of material.

8.0 PAINTING AND PACKING

8.1 The pipes if dispatched to BHEL Stores shall be coated with resin type translucent rust preventive on the outside unless otherwise specified in the Tender/P.O. Pipes of diameter above NB 450 mm, shall be coated inside also.

8.2 The pipes if dispatched to project site directly shall be coated outside & inside as indicated in Tender/P.O.

8.3 **Internal Coating:-** In case of any special coating like PU, Glass Flake, 100% Solid Epoxy etc.. the vendor shall use BHEL approved make/coating materials. And also vendor shall submit Inspection & Testing Plan (ITP) and Procedure for internal coating for BHEL approval.

8.4 Coating shall not be applied for cutback length (as specified in Tender/ PO) from each end to facilitate site joints.





8.5 Spiders are to be provided on both ends of the pipes as per the drawing indicated in the Tender / Purchase Order.

9.0 MARKING

9.1 The following details are to be marked on the pipes for identification.

1) Supplier's emblem/code 2) Size & Specification 3) Material code

4) Pipe number 5) Inspector's seal 6) Work Order-DU details

 J Nanthini Dy.Mgr/QA	 D Sandra Priya Dy.Mgr/QA	 K. Rajitha AGM/MM	 C Saravanan SDGM/Engg	 K V Ramani AGM/Engg & Quality
Prepared By	Reviewed By			Approved By

	Bharat Heavy Electricals Limited, Piping Centre, Chennai	Doc: TDG : 07
	Technical Delivery Conditions for IS 3589 Pipes / Rolled & Welded Pipes using IS2062 plates or IS 10748 coils, confirming to IS 3589.	Rev : 08 Dt : 05.12.2019 Page 3 of 3

	Pipes dispatched to BHEL Stores	Pipes dispatched to BHEL Project Site
Paint Stencilling	Details 1 to 6	Details 1 to 6
Hard Punch	Details 1, 2, & 5	Details 1, 4, 5 & 6

9.2 For the pipe dia 1000mm and above marking shall be done on internal surface in the uncoated area (i.e) within 150mm from pipe ends. The hard punching shall be done at one end and paint stencilling at other end. In case of pipes of dia less than 1000mm the marking shall be done on outside surface.





10.0 **QUALITY PLAN:-** Vendor shall submit QAP for BHEL approval before commencement of production.

11.0 **CERTIFICATES**

11.1 Three original test certificates typed in English shall be submitted along with the inspection report.

11.2 The test certificate shall furnish the following details.

- a. BHEL P.O Number & Amendment Number(if any)
- b. BHEL P.O. Serial Number
- c. Test Certificate number.
- d. Specification, grade, size, quantity
- e. Heat number of plate (or pipe number with traceability to heat number)
- f. Chemical composition and Mechanical properties
- g. Hydrostatic test, UT, RT reports as applicable.
- h. Dimensional report
- i. Painting details

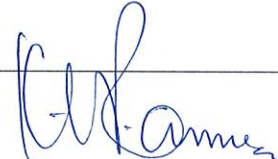
 J Nanthini Dy.Mgr/QA	 D Sandra Priya Dy.Mgr/QA	 K. Rajitha AGM/MM	 C Saravanan SDGM/Engg	 K V Ramani AGM/Engg &Quality
Prepared By	Reviewed By		Approved By	



BHARAT HEAVY ELECTRICALS LIMITED
PIPING CENTRE, MADRAS-600 017

Title : Inspection Procedure for Packing

Specification No : TIP:07:0

Project : All

Material : All

Equipment : -

--	--	--	--	--	--	--	--

Date: 10/09/93

Orig. Issue	Rev. 1	Rev. 2	Rev. 3	Rev. 4	Rev. 5	Rev. 6
-------------	--------	--------	--------	--------	--------	--------

Revised by

Approved by

Distribution :

Piping Centre

Quality Assurance Department

Page 1 of 7

MASTER COPY

1.0 SCOPE

This procedure describes the requirement of Packing and Inspection of packing of raw material and finished products.

2.0 GENERAL REQUIREMENTS FOR ALL PRODUCTS

- 2.1 All packing shall fulfil the following requirements and these requirements shall be checked during inspection.
- 2.2 All bundles shall have identification tags with details such as Material Code, Size, W.O., D.U., Quantity.
- 2.3 Specific instruction given in drawings, Purchase orders, QP, QCP etc. shall be carried out.
- 2.4 All crates /boxes, used shall be covered, fastened tightly and shall have coating or lining inside so as to avoid water seepage into the packing.
- 2.5 PVC coated gunny bags shall be used for packing and bags shall be firmly closed.
- 2.6 All forwarding instruction shall be strictly adhered to.
- 2.7 Tanks and vessels / pipes with attachments shall be positioned in the packing in such way that nozzle and other attachments like stubs, flanges etc. are not loaded.
- 2.8 Except for the structural material and other certain products mentioned in this document, all other products shall not be sent as loose piece. They shall be packed.

3.0 SPECIFIC REQUIREMENTS FOR PRODUCTS

- 3.1 The specific requirements product wise is given below. These requirements shall be adhered to.

3.2 Straight pipes / tubes:

3.2.1 Straight pipes and tube ends shall be covered by end caps as follows:

Type of End cover	Pipe / tube diameter
Plastic end cap	Dia \leq 76mm
Metallic cap	76mm > dia \leq 610mm
Metallic ring	610mm > dia

3.2.2 VCI pellets shall be used for tubes / pipes for diameter upto and including 610mm. Dosage shall be 100gms / cu.m.

3.2.3 VCI pellets shall not be used for SS pipes.

3.2.4 The pipes / tubes upto dia 76mm can be bundled in such a way that weight of the bundle shall not exceed 1000kgs.

3.2.5 The bundle shall be strapped with steel bands at 1 metre interval.

3.2.6 The pipes of dia above 76mm can be despatched loose.

3.3 Pipe Bends including Mitre Bends:

3.3.1 End covering and use of VCI pellets shall be as per 3.2.2. norms and shall be packed in wooden boxes for Nb upto 150mm.

3.3.2 Bends of above Nb 150 can be despatched as loose piece.

3.4 Pipe with attachments:

The packing shall be as per 3.3 and the attachments shall be covered with plastic or metal caps as per 3.2.1.

3.5 Rubber lined pipes and fittings:

Wooden blanks of minimum thickness of 12mm shall be provided at the flange ends. The wooden blanking shall be secured to the flange by 4 bolts and nuts at 90° apart.

3.6 Fittings other than IS:1239:

3.6.1 Fittings of nominal diameter upto Nb 150 and below shall be packed in wooden boxes. The boxes used for this purpose, shall have coating or lining inside so as to avoid any water seepage from outside.

3.6.2 Fittings above Nb 150 can be despatched as loose piece with proper end cover and VCI pellet. See para 3.2.2.

3.7 Tanks and Vessels:

The pipe ends shall be covered with plastic or metal caps as per 3.2.1.

Wooden blanks of minimum thickness of 12mm shall be provided at the flange ends. The wooden blanking shall be secured to the flange by 4 bolts and nuts at 90° apart.

The tank / vessel shall be supported by channel in the packing to avoid transit damage.

3.8 Clamp Assembly:

Components shall be assembled as per drawing. Grease shall be applied on threaded portion and plastic sleeve / VCI coated tape shall be used to protect the threads. All fasteners shall be tightened with spanners to avoid loss during transit. Clamp assemblies upto Nb 100 shall be packed in wooden boxes. Higher sizes can be sent as loose items.

3.9 Clamps and Tube Clips:

3.9.1 Tube Clips

Bundling shall be done in multiples of ten (for long clamps) / twenty (for short clamps) with G.I. wire. Packing shall be in the Standard (shipping) Wooden Box.

3.9.2 Clamps

Clamps shall be bundled with G.I. strap / wire in size wise and shall be packed in wooden box.

3.10 Insulation clamps & fixing components:

Clamps in multiples of 50 shall be bundled with G.I. wire and shall be packed in Standard (shipping) Wooden Box.

3.11 Tie Rods:

Proper rust preventive coating as per relevant painting schedule / QCP / QP shall be applied. Plastic sleeve / VCI coated tapes shall be used to protect the threaded ends. Tie rods shall be bundled size wise as per the table below:

Size -----	No. of piece in bundle -----
M12, M16	30 Max.
M20, M24	25 Max.
M30	Max. quantity restricted by the handling facility.

3.12 Fasteners:

3.12.1 Hex Nuts

Packing shall be in PVC coated polythene bags in multiples of "N" nos. The PVC coated gunny bags with weight not exceeding 10kgs shall be packed in wooden boxes.

The quantity of "N" hexagonal nuts for different sizes shall be as per the table below:

Size of Hex. Nut -----	No. "N" of nuts / Polythene bag -----
Dia ≤ 20mm	100
20mm > dia ≤ 36mm	50
36mm > dia ≤ 56mm	10
56mm > dia	5

3.12.2 Studs and Bolts

All studs and bolts shall be coated with rust preventive. Thread size above M20 shall be protected with plastic sleeve / VCI coated tape. All studs and bolts shall be put in PVC coated gunny bags size wise and DU wise. The PVC coated gunny bag shall be properly closed and packed in wooden boxes.

3.12.3 Washers

Rust preventive coating shall be applied. Packing shall be in PVC coated gunny bags in multiples of 50 nos with weight not exceeding 10kg packed in the wooden box.

3.12.4 Split Pins

Packing shall be in a good quality polythene bag such that each bag shall not weigh more than 0.5kg.

3.13 IS:1239 Black Fitting:

Edge prepared portion and inner portion of the fittings shall be coated with rust preventive. Outside shall be painted as per the relevant TDC.

Packing shall be in VCI coated polythene bag or PVC coated gunny bags with VCI pellet / powder, in multiples of 10 nos , each bag not weighing more than 10kgs. Size NB 150 and below shall be packed in wooden box.

3.14 IS:1239 G.I. Fitting:

Rust preventive shall be applied to threaded portions and packed in plain gunny bag / PVC coated bags with breather holes in multiples of 10 nos. such that each bag not weighing more than 10kgs. Proper end cap shall be provided. Nb 150mm and below shall be packed in wooden boxes.

3.15 CLH Bracket:

The CLH bracket shall be painted and shall be supplied as loose .

3.16 CLH Pins:

Galvanised pins shall be bundled in PVC coated bags with breather holes such that each bundle weighs less than 10kgs.

3.17 Hanger Components:

Hanger components such as weld on / bolt on clevis, eye nuts, turn buckle, bracket with hole, rod couplings shall be painted and the machined portion shall be treated with rust preventive. (GI and yellow chromotised components need not be treated with rust preventive). Packing for items other than galvanised and yellow chromatised, shall be in VCI coated polythene bags or PVC coated gunny bags with VCI pellets / powder, with maximum weight not more than 10kgs, and shall be kept in wooden boxes.

3.18 Rod type clamps:

Rust preventive coating shall be applied for threaded portion. Threads shall be covered with plastic sleeve / bitamax tape. Rods in multiples of 10 shall be bundled with G.I. wire such that weight shall not exceed 10kgs. Final packing shall be in wooden boxes.

3.19 CAF jointing / Rubber gaskets:

The jointing and rubber gaskets shall be rolled and tied before packing it in the wooden crates / boxes.

3.20 Boughtout items:

The suppliers shall use the packing procedures approved by BHEL.