

2- ϕ 20 TAPER (180° EACH)
 PRELIMINARY HOLE (ϕ 20)
 AND COUNTER BORE (ϕ 25)
 SHALL BE DRILLED BY VENDOR
 TAPER MACHINING TOGETHER WITH
 THE LIFTING COLUMN PIPE SHALL BE
 CARRIED OUT DURING ASSEMBLY AT SITE

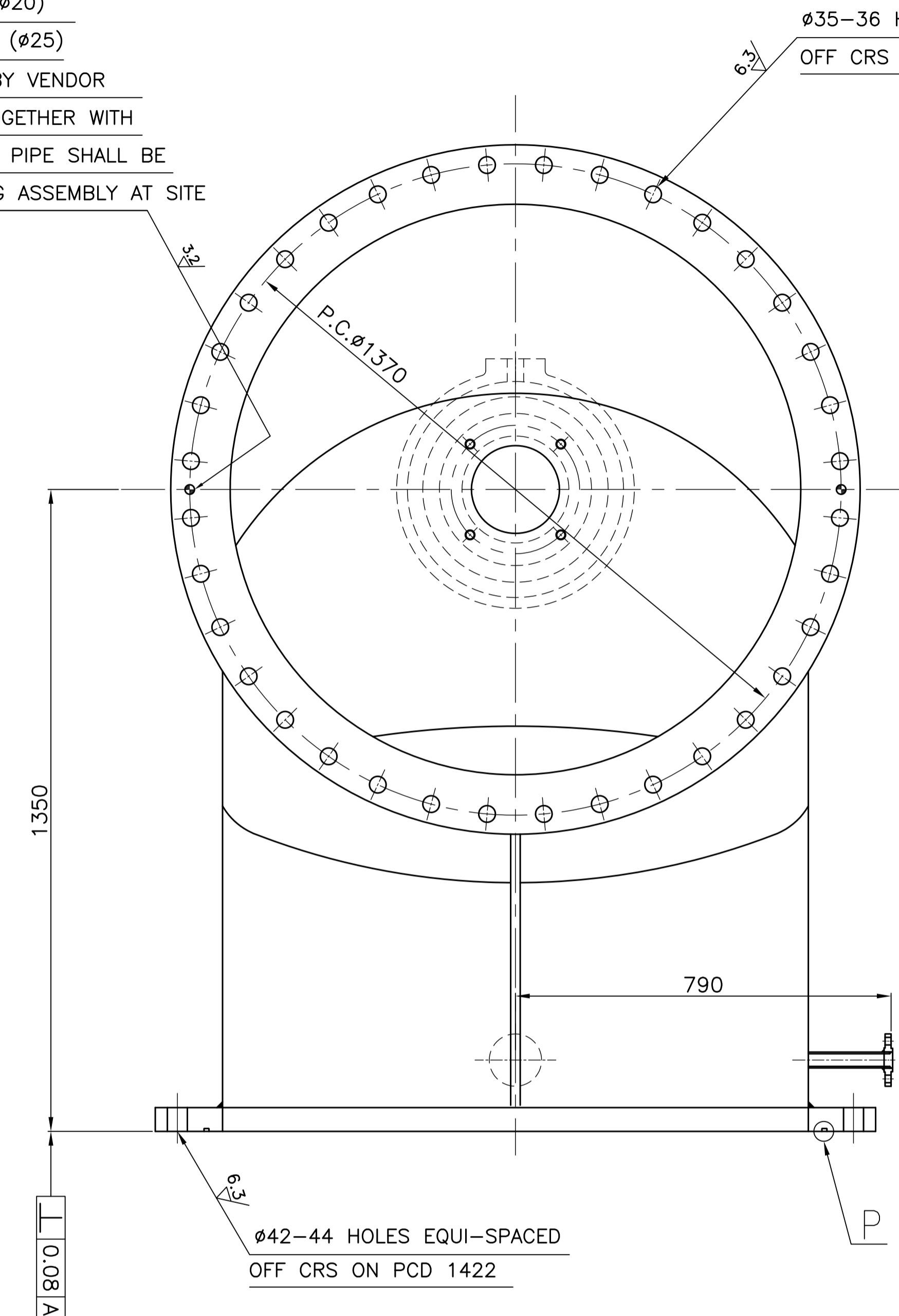

ϕ 35-36 HOLES EQUI-SPACED
 OFF CRS ON PCD 1370

MATERIAL: DUPLEX SS TO UNS 32750
 PREN (%CR+3.3%Mo+16%N) > 38

01

THE INFORMATION ON THIS DOCUMENT IS THE PROPERTY OF BHARAT HEAVY ELECTRICALS LIMITED.
 IT MUST NOT BE USED DIRECTLY OR INDIRECTLY IN ANY WAY DETRIMENTAL TO THE INTEREST OF THE COMPANY.

INVENTORY NO. SIGN. AND DATE REF. DRG. NO. COMPUTER FILE NAME:

REV.	DATE	ALTERED CHECKED	APPD.	REV.	DATE	ALTERED CHECKED	APPD.	REV.	DATE	ALTERED CHECKED	APPD.	REV.	DATE	ALTERED CHECKED	APPD.	REV.	DATE	ALTERED CHECKED	APPD.	REV.	DATE	ALTERED CHECKED	APPD.
1																							
3																							
4																							
5																							
6																							
7																							
8																							
9																							
10																							
11																							

ITEM NO.	DESCRIPTION	DRAWING NO.	VAR. NO.	RAW MATERIAL SIZE OR CASTING DRG.NO. OR FORGING DRG.NO.	MATERIAL CODE	NET WT.	GROSS WT.
01	DISCHARGE ELBOW	1 182 47 1 7018			FP9712011127	1590	1590
					DUPLEX SS 2205 TO UNS 32750		1

THE FOLLOWING CONDITIONS APPLY EXCEPT OTHERWISE STATED

- REF. TO HY0230261 FOR UN TOLERANCES.
- CHAMFER M/CD SHARP ED 1.2 TO 1.0 AT 45°.
- INTERNAL M/CD CORNER RADI 1 TO 0.7.
- THE SURFACE ROUGHNESS WHEREVER NOT SHOWN SHALL BE TAKEN FROM THE SURFACE ROUGHNESS SHOWN OUT SIDE BACK SLASHES GIVEN AT THE TOP MOST RIGHT CORNER OF THE DRG.

TYPE OF PRODUCT OR NAME OF CUSTOMER/PROJECT		CW10M OUTFALL PUMP	
DRN.	SRINIVAS	SIGN.	SRINIVAS
CHD.	SATISH	DATE	28.10.21
APPD.	MSRAM	DATE	28.10.21
APPD.	MSRAM	DATE	28.10.21
DEPT.	PUMPS	SCALE	WEIGHT (KG)
CODE	410	N.T.S	1590
TITLE	DISCHARGE ELBOW (1/2)		REV. NO.
			00
	DRAWING NO. 1 182 47 1 7018		NO. OF SHEETS 02