



PURCHASE-BOI DEPARTMENT
BHARAT HEAVY ELECTRICALS LIMITED,
HEAVY ELECTRICAL EQUIPMENT PLANT,
RANIPUR, HARIDWAR – 249 403 (UTTARAKHAND), INDIA

BHEL Ref. No.: B/4066/2025/3164/V1

Tender Enquiry for the requirement of Double Three Way Valve for DVC Raghunathpur Project

Bids are invited from bidders for the requirement of item **Double Three Way Valve As Per Sl. No. 1, Var.03 of ST47028 Rev.07** for **2X660 MW DVC Raghunathpur (Phase-II) project** as per detailed specifications. All tender documents uploaded along with this tender enquiry are as mentioned below:

LIST OF TENDER DOCUMENTS

S.No.	Document Name & No.	Total Pages
1.	PQR (PRE-QUALIFICATION REQUIREMENT)	02
2.	TECHNICAL SPECIFICATION NO. ST47028 Rev.07	03
3.	ADDITIONAL TERMS & CONDITIONS FOR TENDER (ANNEXURE-A) (in addition to General terms and conditions on GeM 4.0 or latest version as applicable)	16
4.	CHECK-LIST & ANNEXURES	12
5.	BHEL QUALITY PLAN No. QA_BI_QP_101_REV01	03

For and on behalf of BHEL

Engineer (PPX-BOI)
BHEL, HEEP, Haridwar



PPX-BOI DEPARTMENT
BHARAT HEAVY ELECTRICALS LIMITED
HEEP: HARDWAR-249 403 (Uttarakhand)
FAX: +91 1334 226462 TEL: +91 1334 28 1707

PACKAGE- Double 3-Way Valve As Per Sl. No. 1, Var.03
of ST47028 Rev.07

PROJECT: 2X660 MW DVC Raghunathpur (Ph-II) Project

Annexure A

BUYER ADDED BID SPECIFIC ADDITIONAL TERMS AND CONDITIONS (SCOPE OF ENQUIRY):

1. E-bids on GeM are invited from bidders for the supply of **Double Three Way Valve As Per Sl. No. 1, Var.03 of ST47028 Rev.07** for **2X660 MW DVC Raghunathpur (Ph-II) Project** as per requirement mentioned below:

Sl. No.	Material Code & Item Description	Total Quantity (in No.)	Lot No.	Lot Qty (In No.)	Present Material Requirement at site
1.	W90313137188 DOUBLE THREWAY VALVE AS PER SL. NO.01, VAR.03, ST47028 SPEC: ST47028 REV-07	1	1	1	04/08/2027
		1	2	1	04/02/2028

2. Consignee Details:

Sl. No.	Project Name	Site/ Project Address	Requirement Schedule	
1	2X660 MW DVC RAGHUNATHPUR (PH-II)	THE DEPUTY GENERAL MANAGER DAMODOR VALLEY CORPORATION, RTPS 2X660 MW RAGHUNATHPUR TPS (PHASE-II) RAGHUNATHPUR, PURULIA, WEST BENGAL-723133. GSTIN: 19AABCD0541M1ZO A/C. BHARAT HEAVY ELECTRICALS LIMITED	Lot-1	04-08-2027
2			Lot-2	04-02-2028

3. Buyers Specific Additional Terms & Conditions in addition to GTC

Note: Please fill your acceptance/ comments in confirmation column. Blank column will be understood as accepted by bidder.

S. No.	Terms	Description	Bidder's confirmation
1.	Compliance of GTC on GeM	In addition to the terms & conditions mentioned in below table, General Terms and Conditions on GeM 4.0 (Version 1.29) Dt. 25th Mar'2026 or it's latest revision (if revised prior to issuance of enquiry) shall be applicable against this enquiry. Kindly confirm same is acceptable to you.	
2.	Public Procurement (Preference to Make in India)	For this procurement, the local content to categorize, a supplier as a Class-I local supplier/ Class-II local Supplier/Non-Local supplier and purchase preference to Class-I local supplier, is as defined in Public Procurement (Preference to Make in India), PPP-MII Order No. P-45021/ 2/ 2017-PP (BE-II) dtd. 04/06/2020 issued by DPIIT. In case of subsequent Orders issued by the respective Nodal Ministry, changing the definition of local content for the items of the NIT, the same shall be applicable even if issued after issue of this NIT, but before opening of Part-II bids against this NIT.	
		Compliance to Restrictions under Rule 144 (xi) of GFR 2017: I. Any bidder from a country which shares a land border with India will be eligible to bid in this tender only if the bidder is registered with the Competent Authority. The Competent Authority for the purpose of this Clause shall be the Registration Committee constituted by the Department for Promotion of Industry and Internal Trade (DPIIT). II. "Bidder" (including the term 'tenderer', 'consultant' or 'service provider' in certain contexts) means any person or firm or company, including any member of a consortium or joint venture (that is an association of several persons, or firms or companies), every artificial juridical person not falling in	

(Signature of the Vendor with Seal)



		<p>any of the descriptions of bidders stated hereinbefore, including any agency branch or office controlled by such person, participating in a procurement process.</p> <p>III. "Bidder from a country which shares a land border with India" for the purpose of this Clause means: -</p> <ol style="list-style-type: none">An entity incorporated established or registered in such a country; orA subsidiary of an entity incorporated established or registered in such a country; orAn entity substantially controlled through entities incorporated, established or registered in such a country; orAn entity whose beneficial owner is situated in such a country; orAn Indian (or other) agent of such an entity; orA natural person who is a citizen of such a country; orA consortium or joint venture where any member of the consortium or joint venture falls under any of the above. <p>IV. The beneficial owner for the purpose of (III) above will be as under:</p> <ol style="list-style-type: none">In case of a company or Limited Liability Partnership, the beneficial owner is the natural person(s), who, whether acting alone or together or through one or more juridical person, has a controlling ownership interest or who exercises control through other means. Explanation<ol style="list-style-type: none">"Controlling ownership interest" means ownership of or entitlement to more than twenty-five per cent of shares or capital or profits of the company."Control" shall include the right to appoint majority of the directors or to control the management or policy decisions including by virtue of their shareholding or management rights or shareholders agreements or voting agreements.In case of a partnership firm, the beneficial owner is the natural person(s) who, whether acting alone or together, or through one or more juridical person, has ownership of entitlement to more than fifteen percent of capital or profits of the partnership.In case of an unincorporated association or body of individuals, the beneficial owner is the natural person(s), who, whether acting alone or together, or through one or more juridical person has ownership of or entitlement to more than fifteen percent of the property or capital or profits of the such association or body of individuals.Where no natural person is identified under (1) or (2) or (3) above, the beneficial owner is the relevant natural person who holds the position of senior managing official;In case of a trust, the identification of beneficial owner(s) shall include identification of the author of the trust, the trustee, the beneficiaries with fifteen percent or more interest in the trust and any other natural person exercising ultimate effective control over the trust through a chain of control or ownership. <p>V. An Agent is a person employed to do any act for another, or to represent another in dealings with third person. Note:</p> <ol style="list-style-type: none">The bidder shall provide undertaking for their compliance to this Clause, in the format provided in Annexure-13. <p>Registration of the bidder with Competent Authority should be valid at the time of submission of bids and at the time of acceptance of the bids.</p>	
3.	Submission of Offer	The offer/bid shall be signed and stamped on each page by authorized representative of the bidder.	



4.	Documents Checklist:	Please submit signed and stamped copy of your offer on each page along with following documents: <ul style="list-style-type: none">• Buyers' added bid specific additional terms & conditions.• Checklist & annexures (as per formats)• Technical documents, purchase specification• PQR (Pre-Qualification Requirements) related PO & other requisite documents• BHEL Quality Plan QA_BI_QP_101_REV02• Replica of price bid schedule without prices with Part-I offer.	
5.	Special Term	Techno-commercial terms as confirmed in this Annexure-A shall supersede the similar terms & conditions found contradictory written elsewhere in the offer. Kindly confirm the same.	
6.	Evaluation criteria	Evaluation will be done on the basis of total landed cost to BHEL for complete enquiry, with cost involved for delivery up to BHEL project site considering material cost, taxes & duties, Freight etc. for the complete requirement covered in the Bid.	
7.	Bid validity/ Validity of offer	Please note that validity of the offer shall be 180 days from the date opening of Techno-Commercial bid (Part-I bid) on GeM portal. Offer of bidder's having validity less than 180 days shall be liable to get rejected. Please confirm. The required validity is considering that offer is complete & clear w.r.t. PQR and all techno-commercial conditions. Vendors need to extend their offer validity for the time taken by them in responding BHEL's comments/clarification sought during techno-commercial scrutiny of the offer. In case regret by any bidder for such validity extension, their offer shall liable to be reject. Please confirm.	
8.	Pre-Qualification Requirements	<i>The Pre-Qualification Requirements have been enclosed / uploaded with tender documents. All the bidders should ensure submission of complete details and documents as called for in these requirements. The Offers submitted by the bidders would be scrutinized with respect to Pre-Qualification Requirements first. Techno-Commercial offer of only those bidders shall be evaluated who meet the Pre-Qualification Requirements.</i>	
9.	Prices / Basis of quotation:	The offered prices of the items shall remain firm and fixed till the execution of the contract. Please confirm. Prices should be quoted on door delivery basis up to BHEL project site basis i.e. including all taxes, duties, local levies/ transportation/freight charges, packing & forwarding charges etc. The evaluation currency for this tender shall be INR. Please confirm. Transit Insurance would be arranged by BHEL and not to be included in the prices. Bidder to quote prices accordingly. The prices are to be quoted on Ex-Works with freight Pre-paid up to project destination basis. The goods must be dispatched through any Bank approved transporters having their branch at Haridwar. The names and addresses of transporters approved by IBA as well as BHEL are posted at our website www.bhelhwr.co.in . Please note that, if you dispatch the material by any BHEL un-approved transporter then you will necessarily be required to furnish the MRC (Material Receipt Certificate)/ Receipted GR from respective Project Site for processing of your invoice. No demurrage charges would be borne by BHEL.	
10.	Regarding ITC based evaluation bid	Kindly note that this bid/tender has been availed with 100% ITC (Input tax credit) based evaluation. Bidders shall have to enter their Prices inclusive of all taxes including GST during participation in bid on GeM portal and also bidders to add/input the applicable GST amount in percentage separately as per provision made by GeM in the system. Kindly confirm your compliance to the above and submit your offer on GeM portal accordingly.	



11.	Declaration of Consignee Address	Consignee mentioned in GeM enquiry/ PO may be different. However, material to be dispatched to following consignee address: The Deputy General Manager, Damodar Valley Corporation, RTPS 2X660MW Raghunathpur TPP, Phase-II, Raghunathpur, Dist. - Purulia, West Bengal – 723133, A/c Bharat Heavy Electricals Limited.	
12.	Special Instruction of Technical requirement	1.	Bidders to refer BHEL PQR document (ref. STE-TL/DTWV/PQR/2024001 Rev.00 dated 12.06.2024), BHEL specification document ST47028 (Rev. 07) enclosed with this tender enquiry and submit their valuable offer in GeM portal. The Scope of Supply shall include complete valve along with flanges, gaskets, fasteners etc.
		2.	Bidder to keep Two copies of O&M Manual inside the dispatch box of Double 3-Way Valve and also to mention same in vendor's shipping list at the time of dispatches. Also submit PDF copy of O&M Manual to BHEL.
		3.	Material is to be despatched after receipt of MDCC on Door Delivery Basis to BHEL project site. Invoice, GR/LR, Packing list, Test Certificate/ Inspection reports, O&M Manual, Guarantee Certificate, GST compliance certificate are required in Original along with copy of E-Way bill after dispatch.
13.	Specification confirmation	Kindly confirm that quoted offer by you have been complied all technical requirements as given in tender documents and submit all documents to BHEL as per tender specifications/ drawings without any deviations.	
14.	Quality Requirements	Vendor to confirm and endorse the BHEL SQP QA_BI_QP_101, REV02.	
		Inspection shall be done by BHEL Nominated TPIA (M/s QUEST) As Per BHEL SQP QA_BI_QP_101, REV02. Please confirm.	
15.	Special Instruction:	Please note that as per BHEL's Policy, we cannot allow Price impact for the requirement / scope of supply, which is a part of specifications of our tender enquiry. Hence please read all specification / documents thoroughly and submit your offer as per specifications of tender enquiry. In case of any confusion / un-clarity on any of the clause / requirement of specification, please clarify the same from BHEL before submission of offer. Deviation / request regarding un-clarity / contradictory conditions / ambiguity of specifications would not be entertained after opening of techno-commercial offers. Further no price impact would be allowed for the requirement which is already part of the specifications of the tender enquiry, after opening of techno-commercial offers. Please note and confirm.	
16.	Document submission for approval from BHEL/ Customer	Drawings/Data sheets/documents etc. as called for in the specifications shall be submitted by Vendor for BHEL/ Customer approval within 30 days of purchase order. BHEL shall approve these drawings/data sheets/ documents etc. within 30 days of receipt. Any comments on the documents shall be given by BHEL within 7 days of submission and vendor shall submit revised document / reply to comments, within 7 days of BHEL comments. However, total time for Document approval submission and approval shall not exceed 30 days for respective party. Delivery is from the date of PO, accordingly, delay in submission / revision of the documents by the vendor will automatically account for to vendor. In case of delay on account of BHEL in comments / approval of the documents, the delivery shall be re-scheduled by the no of days taken by BHEL in excess to 30 days. For delay analysis cumulative no of days (including time taken in comments), shall be considered for delivery extension.	



17.	GeM charges	GeM charges if any shall be either side only i.e. buyer's GeM charges shall be in buyer's account and seller's GeM charges shall be on seller's account. Please confirm.									
18.	Contract execution	Bidder's are advised to read GeM related query & clarification carefully on GeM portal. Order shall be executed through GeM.									
19.	Payment Terms:	<p>100% payment will be released within tabulated timeline from date of LR Receipt/ material receipt at site (MRC) and On-line submission of bills.</p> <p>Consignee Receipt-Cum-Acceptance Certificate (CRAC) is also required for bill processing.</p> <p>The timeline for payments will be as under:</p> <table border="1"><thead><tr><th>Type of Bidder</th><th>Payment Terms (Number of Days from Material receipt at site)</th></tr></thead><tbody><tr><td>Micro & Small Enterprises (MSEs)</td><td>45 days</td></tr><tr><td>Medium Enterprises</td><td>60 days</td></tr><tr><td>Non MSME</td><td>90 days</td></tr></tbody></table> <p>Vendor to submit MSME certificate with offer in view of above and claim the same on GeM during offer submission.</p> <p>The Payment terms are subject to receipt of non-discrepant document from supplier. Please confirm.</p>	Type of Bidder	Payment Terms (Number of Days from Material receipt at site)	Micro & Small Enterprises (MSEs)	45 days	Medium Enterprises	60 days	Non MSME	90 days	
Type of Bidder	Payment Terms (Number of Days from Material receipt at site)										
Micro & Small Enterprises (MSEs)	45 days										
Medium Enterprises	60 days										
Non MSME	90 days										
20.	Documents required for Bill processing:	<p>The following documents are required to be sent for Bill Processing:</p> <ul style="list-style-type: none">• Original Tax Invoice (E-invoice, if the turnover exceeded Rs. 5 cr. in any financial year from 2017-18, else, a declaration for the same is required for processing of bill.)• Original LR• Packing list• Copy of E-way Bill• Guarantee/Warrantee certificate• Copy of MDCC issued by BHEL• Receipted Copy of LR / Proof of delivery (POD) / Material Receipt Certificate (MRC) from BHEL site• GST Compliance declaration• GeM Invoice• Consignee Receipt Cum Acceptance Certificate (CRAC)• Digitally Signed Invoice along with supporting documents to be uploaded at B2B Portal of BHEL Haridwar. https://suvidha.bhel.in/suvidha/• Rest documents as mentioned in the PO remarks.									
21.	MDCC clause	<p>Material shall be dispatched only after issue of material dispatch clearance certificate (MDCC) by BHEL. All test certificates/ Inspection Reports/COC and relevant documents are to be sent to BHEL before dispatch of material for issue of MDCC, which will be issued after review of test certificates/report/COC etc. MDCC will be issued within 07 days of receipt of these documents once found complete in all respects. In case of any delay on account of BHEL in issuing MDCC, delivery shall be extended by no. of days in excess of 7 days taken by BHEL in issuing MDCC and delays shall be dealt on merit basis.</p> <p>Material is to be dispatched within 07 days of receipt of MDCC from BHEL without waiting for PO amendment.</p>									



22.	Packing	Each item must be tagged with description & quantity same as in Vendor's Packing List. Kindly confirm.	
		Please ensure proper and sturdy packing suitable for handling at site or during transportation up to site in healthy condition.	
23.	Quantity Variation	<p>BHEL reserves the right to cancel tender or reject any or all the quotations without assigning any reasons thereof.</p> <p>BHEL also reserves the right to increase or decrease the tendered quantities or quantity of individual material code may be dropped as a whole also.</p> <p>Vendors should be prepared to accept order for reduced Quantity without any extra charges. Vendor should also be prepared for giving discount in case of Increase in Quantity.</p> <p>Vendor has to take manufacturing clearance from BHEL before starting manufacturing of material. In case ordered quantity is reduced at the time of manufacturing clearance, then payment shall be made accordingly as per decreased quantity.</p> <p>Kindly confirm.</p>	
24.	Delivery Schedule/ Period	<p>Delivery schedule mentioned in GeM enquiry is tentative and may revise after placement of PO as per delivery schedule mentioned in scope of enquiry or agreed delivery schedule in line with manufacturing period quoted by vendor and accepted by BHEL, whichever is later.</p> <p>However, Bidder may quote their best possible delivery.</p> <p>Kindly confirm.</p>	
25.	Liquidated Damages (LD) for late delivery	<p>If the Seller/Service Provider fails to deliver any or all of the Goods/Services within the original/re-fixed delivery period(s) specified in the contract, the Buyer will be entitled to deduct/recover the Liquidated Damages for the delay, unless covered under Force Majeure conditions aforesaid, @ 0.5% of the contract value per week or part of the week of delayed period as pre-estimated damages not exceeding 10% of the contract value without any controversy/dispute of any sort whatsoever.</p>	
		<p>The date of dispatch mentioned on LR/GR would be treated as the date of delivery for penalty purposes.</p>	
26.	GST Penalty	<p>Vendor to provide dispatch documents to BHEL Haridwar in the same month of dispatch of material. In case of delay in submission of the same, Any GST penalty levied due to change of month of billing to End customer with respect to LR date will be borne by vendor. Please confirm.</p>	
27.	Guarantee	<p>Kindly confirm that Guarantee would be provided for a period of "18 months after delivery or 12 months after commissioning, whichever is earlier".</p> <p>Supplier shall be responsible for free replacement of defective equipment / material at BHEL site.</p>	
		<p>Please note that offers with guarantee period lesser than above mentioned guarantee period may result in rejection of the offer.</p>	
28.	Settlement of Dispute, Conciliation & Arbitration:	<p>Settlement of Dispute</p> <p>If any dispute or difference of any kind whatsoever shall arise between BHEL and the Supplier/Vendor, arising out of the contract for the performance of the work whether during the progress of contract termination, abandonment or breach of the contract, it shall in the first place referred to Designated Officer / IEM for amicable resolution by the parties. Designated Officer / IEM who within 60 days after being requested shall give written notice of his decision to the contractor. Save as hereinafter provided, such decision in respect of every matter so referred shall forthwith be given effect to by the Supplier/Vendor who shall proceed with the work with all due diligence, whether he or BHEL desires to resolve the dispute as hereinafter provided or not. If after the Designated Engineer has given written notice of this decision to the party and no intention to pursue the dispute has been communicated to him by the affected party within 30 days from the receipt of such notice, the said decision shall become final and binding on the parties. In the event the Supplier/Vendor being dissatisfied with any such decision or if amicable settlement cannot be reached then all such disputed issues shall be resolved through conciliation in terms of the BHEL Conciliation Scheme 2018 as per 'CONCILIATION' Clause.</p> <p>CONCILIATION:</p> <p>Any dispute, difference or controversy of whatever nature howsoever arising under or out of or in relation to this Agreement (including its interpretation) between the Parties, and so notified in writing by either Party to the other Party (the "Dispute") shall, in the first instance, be attempted to be resolved amicably in accordance with the conciliation procedure as per BHEL Conciliation Scheme 2018. The</p>	



proceedings of Conciliation shall broadly be governed by Part-III of the Arbitration and Conciliation Act 1996 or any statutory modification thereof and as provided in - "Procedure for conduct of conciliation proceedings" (as available in www.bhel.com).

Note: Ministry of Finance has issued OM reference No. 1/2/24 dated 03.06.2024 regarding "Guidelines for Arbitration and Mediation in Contracts of Domestic Public Procurement. In the said OM it has been recommended that Government departments/ Entities/agencies are to encourage mediation under the Mediation Act. 2023. The said Act has not yet been notified by the Government. Therefore, the clause "Settlement of Disputes" shall be modified accordingly as and when the Mediation Act 2023 gets notified.

ARBITRATION:

Except as provided elsewhere in this Contract, in case Parties are unable to reach amicable settlement (whether by Conciliation to be conducted as provided herein above or otherwise) in respect of any dispute or difference; arising out of the formation, breach, termination, validity or execution of the Contract; or, the respective rights and liabilities of the Parties; or, in relation to interpretation of any provision of the Contract; or, in any manner touching upon the Contract (hereinafter referred to as the 'Dispute'), then, either Party may, refer the disputes to Arbitral Institution and such dispute to be adjudicated by Sole Arbitrator appointed in accordance with the Rules of said Arbitral Institution.

A party willing to commence arbitration proceeding shall invoke Arbitration Clause by giving notice to the other party in terms of section 21 of the Arbitration & Conciliation Act, 1996 (hereinafter referred to as the 'Notice') before referring the matter to arbitral institution. The Notice shall be addressed to the Head of the Region, Power Sector/ Unit, BHEL, executing the Contract and shall contain the particulars of all claims to be referred to arbitration with sufficient detail and shall also indicate the monetary amount of such claim including interest, if any.

After expiry of 30 days from the date of receipt of aforesaid notice, the party invoking the Arbitration shall submit that dispute to the Arbitral Institutions (shall be identified by the contract issuing agency) and that dispute shall be adjudicated in accordance with their respective Arbitration Rules. The matter shall be adjudicated by a Sole Arbitrator who shall necessarily be a Retd Judge having considerable experience in commercial matters to be appointed/nominated by the respective institution. The cost/expenses pertaining to the said Arbitration shall also be governed in accordance with the Rules of the respective Arbitral Institution. The decision of the party invoking the Arbitration for reference of dispute to a specific Arbitral institution for adjudication of that dispute shall be final and binding on both the parties and shall not be subject to any change thereafter. The institution once selected at the time of invocation of dispute shall remain unchanged.

The fee and expenses shall be borne by the parties as per the Arbitral Institutional rules.

The Arbitration proceedings shall be in English language and the seat and venue of Arbitration shall be at the court(s) of Haridwar.

Subject to the above, the provisions of Arbitration & Conciliation Act 1996 and any amendment thereof shall be applicable. All matters relating to this Contract and arising out of invocation of Arbitration clause are subject to the exclusive jurisdiction of the Court(s) situated at Haridwar, shall have exclusive jurisdiction.

Notwithstanding any reference to the Designated Engineer or Conciliation or Arbitration herein, a. the parties shall continue to perform their respective obligations under the Contract unless they otherwise agree. Settlement of Dispute clause cannot be invoked by the Contractor, if the Contract has been mutually closed or 'No Demand Certificate' has been furnished by the Contractor or any Settlement Agreement has been signed between the Employer and the Contractor.

It is agreed that Mechanism of resolution of disputes through arbitration shall be available only in the cases where the value of the dispute is less than Rs. 10 Crores.

In case the disputed amount Claim, Counter claim including interest is Rs. 10 crores and above, the parties shall be within their rights to take recourse to remedies other than Arbitration, as may be available to them under the applicable laws after prior intimation to the other party. Subject to the aforesaid conditions, provisions of the Arbitration and Conciliation Act, 1996 and any statutory



		<p>modifications or re-enactment thereof as amended from time to time, shall apply to the arbitration proceedings under this clause.</p> <p>In case, multiple arbitrations are invoked (whether sub-judice or arbitral award passed) by any party to under this contract, then the cumulative value of claims (including interest claimed or awarded) in all such arbitrations shall be taken in account while arriving at the total claim in dispute for the subject contract for the purpose of clause mentioned above. Disputes having cumulative value of less than 10 crores shall be resolved through arbitration and any additional dispute shall be adjudicated by the court of competent jurisdiction.</p>	
29.	Breach of Contract, Remedies and Termination:	<p>The following shall amount to breach of contract:</p> <p>I. Non-supply of material/ non-completion of work by the Supplier/Vendor within scheduled delivery/ completion period as per contract or as extended from time to time.</p> <p>II. The Supplier/Vendor fails to perform as per the activity schedule and there are sufficient reasons even before expiry of the delivery/ completion period to justify that supplies shall be inordinately delayed beyond contractual delivery/ completion period.</p> <p>III. The Supplier/Vendor delivers equipment/ material not of the contracted quality.</p> <p>IV. The Supplier/Vendor fails to replace the defective equipment/ material/ component as per guarantee clause.</p> <p>V. Withdrawal from or abandonment of the work by the Supplier/Vendor before completion as per contract.</p> <p>VI. Assignment, transfer, subletting of Contract by the Supplier/Vendor without BHEL's written permission resulting in termination of Contract or part thereof by BHEL.</p> <p>VII. Non-compliance to any contractual condition or any other default attributable to Supplier/Vendor.</p> <p>VIII. Any other reason(s) attributable to Vendor towards failure of performance of contract. In case of breach of contract, BHEL shall have the right to terminate the Purchase Order/ Contract either in whole or in part thereof without any compensation to the Supplier/Vendor.</p> <p>IX. Any of the declarations furnished by the contractor at the time of bidding and/ or entering into the contract for supply are found untruthful and such declarations were of a nature that could have resulted in non-award of contract to the contractor or could expose BHEL and/ or Owner to adverse consequences, financial or otherwise.</p> <p>X. Supplier/Vendor is convicted of any offence involving corrupt business practices, antinational activities or any such offence that compromises the business ethics of BHEL, in violation of the Integrity Pact entered into with BHEL has the potential to harm the overall business of BHEL/ Owner.</p> <p>Note-Once BHEL considers that a breach of contract has occurred on the part of Supplier/Vendor, BHEL shall notify the Supplier/Vendor by way of notice in this regard. Contractor shall be given an opportunity to rectify the reasons causing the breach of contract within a period of 14 days.</p> <p>In case the contractor fails to remedy the breach, as mentioned in the notice, to the satisfaction of BHEL, BHEL shall have the right to take recourse to any of the remedial actions available to it under the relevant provisions of contract.</p> <p>Remedies in case of Breach of Contract.</p> <p>i) Wherein the period as stipulated in the notice issued under above clause has expired and Supplier/Vendor has failed to remedy the breach, BHEL will have the right to terminate the contract on the ground of "Breach of Contract" without any further notice to contractor.</p> <p>ii) Upon termination of contract, BHEL shall be entitled to recover an amount equivalent to 10% of the Contract Value for the damages on account of breach of contract committed by the Supplier/Vendor. This amount shall be recovered by way of encashing the security instruments like performance bank guarantee etc available with BHEL against the said contract. In case the value of the security instruments available is less than 10% of the</p>	



		<p>contract value, the balance amount shall be recovered from other financial remedies (i.e. available bills of the Supplier/Vendor, retention amount, from the money due to the Supplier/Vendor etc. with BHEL) or the other legal remedies shall be pursued.</p> <p>iii) wherever the value of security instruments like performance bank guarantee available with BHEL against the said contract is 10% of the contract value or more, such security instruments to the extent of 10% contract value will be encashed. In case no security instruments are available or the value of the security instruments available is less than 10% of the contract value, the 10% of the contract value or the balance amount, as the case may be, will be recovered in all or any of the following manners:</p> <p>iv) In case the amount recovered under sub clause (a) above is not sufficient to fulfil the amount recoverable then; a demand notice to deposit the balance amount within 30 days shall be issued to Supplier/Vendor.</p> <p>v) If Supplier/Vendor fails to deposit the balance amount within the period as prescribed in demand notice, following action shall be taken for recovery of the balance amount:</p> <p>a) from dues available in the form of Bills payable to defaulted Supplier/Vendor against the same contract.</p> <p>b) If it is not possible to recover the dues available from the same contract or dues are insufficient to meet the recoverable amount, balance amount shall be recovered from any money(s) payable to Supplier/Vendor under any contract with other Units of BHEL including recovery from security deposits or any other deposit available in the form of security instruments of any kind against Security deposit or EMD.</p> <p>vi) In-case recoveries are not possible with any of the above available options, Legal action shall be initiated for recovery against defaulted supplier/Vendor.</p> <p>vii) It is an agreed term of contract that this amount shall be a genuine pre-estimate of damages that BHEL would incur in completion of balance contractual obligation of the contract through any other agency and BHEL will not be required to furnish any other evidence to the Supplier/Vendor for the purpose of estimation of damages.</p> <p>viii) In addition to the above, imposition of liquidated damages, debarment, termination, de-scoping, short-closure, etc., shall be applied as per provisions of the contract.</p> <p>Note:</p> <p>1) The defaulting Supplier/Vendor shall not be eligible for participation in any of the future enquiries floated by BHEL to complete the balance work. The defaulting contractor shall mean and include:</p> <p>(a) In case defaulted Supplier/Vendor is the Sole Proprietorship Firm, any Sole Proprietorship Firm owned by same Sole Proprietor.</p> <p>(b) In case defaulted Supplier/Vendor is The Partnership Firm, any firm comprising of same partners/ some of the same partners; or sole proprietorship firm owned by any partner(s) as a sole proprietor.</p>	
30.	Suspension of Business Dealings with Suppliers / Contractors:	<p>The offers of the bidders who are under suspension as also the offers of the bidders, who engage the services of the banned firms / principal / agents, shall be rejected. The list of banned firms is available on BHEL web site www.bhel.com.</p> <p>If any bidder / supplier / contractor during pre-tendering / tendering / post tendering / award / execution / post-execution stage indulges in any act, including but not limited to, mal-practices, cheating, bribery, fraud or and other misconduct or formation of cartel so as to influence the bidding process or influence the price or tampers the tendering process or acts or omits in any manner which tantamount to an offence punishable under any provision of the Indian Penal Code, 1860(Bhartiya Nyaya Samhita 2023) or any other law in force in India, or does anything which is actionable under the Guidelines for Suspension of Business dealings, action may be taken against such bidder / supplier / contractor as per extant guidelines of the company available on www.bhel.com and / or under applicable legal provisions. Guidelines for suspension of business dealings is available in the webpage: http://www.bhel.com/vender_registration/vender.php.</p>	



31.	Conflict of Interest Among Bidders/ Agents	<p>A bidder shall not have conflict of interest with other bidders. Such conflict of interest can lead to anti-competitive practices to the detriment of Procuring Entity's interests. The bidder found to have a conflict of interest shall be disqualified. A bidder may be considered to have a conflict of interest with one or more parties in this bidding process, if:</p> <p>a) they have controlling partner (s) in common; or</p> <p>b) they receive or have received any direct or indirect subsidy/ financial stake from any of them; or</p> <p>c) they have the same legal representative/agent for purposes of this bid; or</p> <p>d) they have relationship with each other, directly or through common third parties, that puts them in a position to have access to information about or influence on the bid of another Bidder, or</p> <p>e) Bidder participates in more than one bid in this bidding process. Participation by a Bidder in more than one Bid will result in the disqualification of all bids in which the parties are involved. However, this does not limit the inclusion of the components/ sub-assembly/ Assemblies from. one bidding manufacturer in more than one bid; or</p> <p>f) In cases of agents quoting in offshore procurements, on behalf of their principal manufacturers, one agent cannot represent two manufacturers or quote on their behalf in a particular tender enquiry. One manufacturer can also authorise only one agent/dealer. There can be only one bid from the following:</p> <p>1. The principal manufacturer directly or through one Indian agent on his behalf; and</p> <p>2. Indian/foreign agent on behalf of only one principal, or</p> <p>g) A Bidder or any of its affiliates participated as a consultant in the preparation of the design or technical specifications of the contract that is the subject of the Bid, or</p> <p>h) In case of a holding company having more than one independently manufacturing units, or more than one unit having common business ownership/management, only one unit should quote. Similar restrictions would apply to closely related sister companies. Bidders must proactively declare such sister/ common business/ management units in same/ similar line of business. "</p>													
32.	Micro and Small Enterprises (MSE):	<p>Any Bidder falling under MSE category shall furnish the following details & submit documentary evidence/ Govt. Certificate etc. in support of the same along with their techno-commercial offer.</p> <table border="1" data-bbox="349 1113 1282 1249"><thead><tr><th>Type under MSE</th><th>SC/ST owned</th><th>Women owned</th><th>Others (excluding SC/ ST & Women Owned)</th></tr></thead><tbody><tr><td>Micro</td><td></td><td></td><td></td></tr><tr><td>Small</td><td></td><td></td><td></td></tr></tbody></table> <p>Note: If the bidder does not furnish the above, offer shall be processed construing that the bidder is not falling under MSE category.</p> <p>a) MSE suppliers can avail the intended benefits in respect of the procurements related to the Goods and Services only (Definition of Goods and Services as enumerated by Govt. of India vide Office Memorandum F. No. 21(8)/2011-MA dtd. 09/11/2016 office of AS & DC, MSME) only if they submit along with the offer, attested copies of either Udyam Registration. Date to be reckoned for determining the deemed validity will be the last date of Technical Bid submission. Non-submission of supporting document in GeM portal will lead to consideration of their bids at par with other bidders. No benefits shall be applicable for this enquiry if the above required documents are not uploaded at the time of bid submission. Documents submitted by the bidder shall be verified by BHEL for rendering the applicable benefits.</p>	Type under MSE	SC/ST owned	Women owned	Others (excluding SC/ ST & Women Owned)	Micro				Small				
Type under MSE	SC/ST owned	Women owned	Others (excluding SC/ ST & Women Owned)												
Micro															
Small															
33.	Jurisdiction:	<p>This contract shall be governed by the Law for the time being in force in the Republic of India. Subject to clause(s) mentioned above of this contract, the Civil Court having original Civil Jurisdiction at Haridwar shall alone have exclusive jurisdiction in regard to all matters in respect of the Contract.</p>													



34.	Force Majeure	<p>"Force Majeure" shall mean circumstance which is: a) beyond control of either of the parties to contract, b) either of the parties could not reasonably have provided against the event before entering into the contract, c) having arisen, either of the parties could not reasonably have avoided or overcome, and d) is not substantially attributable to either of the parties And Prevents the performance of the contract, Such circumstances include but shall not be limited to: i) War, hostilities , invasion, act of foreign enemies. ii) Rebellion, terrorism, revolution, insurrection, military or usurped power, or civil war. iii) Riot, commotion or disorder by persons other than the contractor's personnel and other employees of the contractor and sub-contractors. iv) Strike or lockout not solely involving the contractor's personnel and other employees of the contractor and sub-contractors. v) Encountering munitions of war, explosive materials, ionizing radiation or contamination by radio-activity, except as may be attributable to the contractor's use of such munitions, explosives, radiation or radio- activity. vi) Natural catastrophes such as earthquake, tsunami, volcanic activity, hurricane or typhoon, flood, fire, cyclones etc. vii) Epidemic, pandemic etc.</p> <p>The following events are explicitly excluded from Force Majeure and are solely the responsibilities of the non-performing party: a) any strike, work-to-rule action, go slow or similar labour difficulty (b) late delivery of equipment or material (unless caused by Force Majeure event) and (c) economic hardship.</p> <p>If either party is prevented, hindered or delayed from or in performing any of its obligations under the Contract by an event of Force Majeure, then it shall notify the other in writing of the occurrence of such event and the circumstances thereof within 15 (fifteen) days after the occurrence of such event.</p> <p>The party who has given such notice shall be excused from the performance or punctual performance of its obligations under the Contract for so long as the relevant event of Force Majeure continues and to the extent that such party's performance is prevented, hindered or delayed. The Time for Completion shall be extended by a period of time equal to period of delay caused due to such Force Majeure event.</p> <p>Delay or non-performance by either party hereto caused by the occurrence of any event of Force Majeure shall not</p> <p>i) Constitute a default or breach of the Contract. ii) Give rise to any claim for damages or additional cost expense occasioned thereby, if and to the extent that such delay or non-performance is caused by the occurrence of an event of Force Majeure.</p> <p>BHEL at its discretion may consider short closure of contract after 1 year of imposition of Force Majeure in line with extant guidelines. In any case, Supplier/Vendor cannot consider deemed short-closure after 1 year of imposition of Force Majeure.</p>	
35.	Cartel Formation	<p>The Bidder declares that they will not enter into any illegal or undisclosed agreement or understanding, whether formal or informal with other Bidder(s). This applies in particular to prices, specifications, certifications, subsidiary contracts, submission or non-submission of bids or any other actions to restrict competitiveness or to introduce cartelization in the bidding process. In case, the Bidder is found having indulged in above activities, suitable action shall be taken by BHEL as per extant policies/ guidelines.</p>	
36.	Fraud Prevention Policy:	<p>Bidder along with its associate /collaborators /sub-contractors /sub-vendors / consultants / service providers shall strictly adhere to BHEL Fraud Prevention Policy displayed on BHEL website http://www.bhel.com and shall immediately bring to the notice of BHEL Management about any fraud or suspected fraud as soon as it comes to their notice.</p>	
37.	Action against Bidder/ vendor/ supplier/ contractor in case of default:	<p>In order to protect the commercial interests of BHEL, BHEL shall take action against supplies / contractors by way of suspension of business dealings, who either fail to perform or are in default without any reasonable cause, cause loss of business/ money/ reputation, indulge in malpractices, cheating, bribery, fraud or any other misconduct or formation of cartels so as to influence the bidding process or influence the price etc.</p> <p>Suspension of Business Dealings could be in the form of "Hold" or "Banning" a supplier/ contractor or a bidder and shall be as per "Guidelines for Suspension of Business Dealings with Suppliers/ Contractors" available at BHEL's website.</p> <p>https://www.bhel.com/guidelines-suspension-business-dealings-supplierscontractors</p>	



38.	Order of Precedence:	In the event of any ambiguity or conflict between the Tender Documents, the order of precedence shall be in the order below: a. Amendments/Clarifications/Corrigenda/Errata etc. issued in respect of the tender documents by BHEL. b. Buyer Added Bid Specific ATC c. GeM Bid Technical Conditions of Contract (TCC) d. GeM GTC	
39.	Bid to RA	Applicable as per GeM NIT	
40.	Note:	<ol style="list-style-type: none">1. In the event of our customer order covering this tender being cancelled /placed on hold /otherwise modified, BHEL would be constrained to accordingly cancel / hold / modify the tender at any stage of execution.2. BHEL may negotiate the L1 rate, if not meeting our budget / estimated cost. BHEL may re-float the tender opened, if L1 price is not acceptable to BHEL even after negotiation. Any deviation from the conditions specified in Techno-Commercial Terms and Conditions - Buyer Added Bid Specific Additional Terms & Conditions (ATC) and Technical specifications and requirements will lead to rejection of offer.3. Any change in applicable rates of Tax or any other statutory levies (Direct / Indirect) or any new introduction of any levy by means of statute and its corresponding liability for the deliveries beyond the agreed delivery date for reasons not attributable to BHEL will be to vendors account. BHEL will not reimburse the same and any subsequent claim in this respect will be summarily rejected.4. BHEL reserves its right to reject an offer due to unsatisfactory past performance by the respective Vendor in the execution of any contract to any BHEL project / Unit.5. The offers of the bidders who are under suspension and also the offers of the bidders, who engage the services of the banned firms /principal/agents, shall be rejected. The list of banned firms is available on BHEL website www.bhel.com.6. Recovery / deduction as applicable as per Direct and Indirect taxes as notified by Govt. Of India from time to time will be made and information/certificate for such deduction/recoveries shall be provided by BHEL to the vendor.	
41.	Enclosure:	<ol style="list-style-type: none">1. Annexure-1: Check List. -Applicable2. Annexure-2: Offer forwarding letter / tender submission letter -Applicable3. Annexure-3: No Deviation Certificate -Applicable4. Annexure-4: Declaration regarding Insolvency/ Liquidation/ Bankruptcy Proceedings - Applicable5. Annexure-5: Declaration by Authorized Signatory -Applicable (if required)6. Annexure-6: Declaration by Authorized Signatory regarding Authenticity of submitted Documents -Applicable7. Annexure-7: Non-Disclosure Certificate -Not Applicable8. Annexure-8: Integrity Pact -Not Applicable9. Annexure-9: Declaration confirming knowledge about Site Conditions -Not Applicable10. Annexure-10: Declaration reg. Related Firms & their areas of Activities -Applicable	



PPX-BOI DEPARTMENT
BHARAT HEAVY ELECTRICALS LIMITED
HEEP: HARDWAR-249 403 (Uttarakhand)
FAX: +91 1334 226462 TEL: +91 1334 28 1707

PACKAGE- Double 3-Way Valve As Per Sl. No. 1, Var.03
of ST47028 Rev.07
PROJECT: 2X660 MW DVC Raghunathpur (Ph-II) Project

		<p>11. Annexure-11: Declaration for relation in BHEL –Applicable</p> <p>12. Annexure- 12: Declaration reg. minimum local content in line with revised public procurement –Applicable</p> <p>13. Annexure- 13: Declaration regarding compliance to Restrictions under Rule 144 (xi) of GFR 2017 –Applicable</p> <p>14. Annexure-14: Bank Account Details for E-Payment – Applicable for Successful Vendor</p> <p>15. Annexure-15: Power of Attorney for submission of tender. –Not Applicable</p> <p>16. Annexure-16: Proforma of Bank Guarantee for Earnest Money. –Not Applicable</p> <p>17. Annexure-17: Proforma of Bank Guarantee for Performance Security. –Not Applicable</p> <p>18. Annexure-18: List of Consortium Bank. –Not Applicable</p> <p>19. Annexure-19: Declaration for treatment of cases regarding conflict of interest. – Applicable</p>			
42.	Contact detail of Bidder:	<p>For necessary communication, bidders are requested to provide the below details -</p> <p>1.Name of Contact Persons & Mobile numbers:</p> <p>_____</p> <p>_____</p> <p>2. Official email ids (at least two or three email id): _____</p> <p>_____</p> <p>3. Works address / Location:</p> <p>_____</p> <p>_____</p>			
43.	For clarifications:	<p>Bid should be free from correction, overwriting, using corrective fluid, etc. Any interlineation, cutting, erasure or overwriting shall be valid only if they are attested under full signature(s) of person(s) signing the bid else bid shall be liable for rejection. In the event of any Technical or Commercial queries, the same may please be addressed to the following BHEL concerned before Part I opening -</p> <table border="1"><tr><td>Mr. Rahul Kumar Rahi Designation: Engineer (PPX-BOI) 4th Floor, Main Administrative Building, HEEP, BHEL, Hardwar- 249403 Uttarakhand, India Email ID: rkrahi@bhel.in Tel: +91 1334 28 1707</td><td>Mr. Sagar Gupta Designation: Manager (PPX-BOI) 4th Floor, Main Administrative Building, HEEP, BHEL, Hardwar- 249403 Uttarakhand, India Email ID: sagargupta@bhel.in Tel: +91 1334 28 1045</td></tr></table>	Mr. Rahul Kumar Rahi Designation: Engineer (PPX-BOI) 4 th Floor, Main Administrative Building, HEEP, BHEL, Hardwar- 249403 Uttarakhand, India Email ID: rkrahi@bhel.in Tel: +91 1334 28 1707	Mr. Sagar Gupta Designation: Manager (PPX-BOI) 4 th Floor, Main Administrative Building, HEEP, BHEL, Hardwar- 249403 Uttarakhand, India Email ID: sagargupta@bhel.in Tel: +91 1334 28 1045	
Mr. Rahul Kumar Rahi Designation: Engineer (PPX-BOI) 4 th Floor, Main Administrative Building, HEEP, BHEL, Hardwar- 249403 Uttarakhand, India Email ID: rkrahi@bhel.in Tel: +91 1334 28 1707	Mr. Sagar Gupta Designation: Manager (PPX-BOI) 4 th Floor, Main Administrative Building, HEEP, BHEL, Hardwar- 249403 Uttarakhand, India Email ID: sagargupta@bhel.in Tel: +91 1334 28 1045				



44. **DECLARATION REGARDING MINIMUM LOCAL CONTENT IN LINE WITH**

REVISED PUBLIC PROCUREMENT (PREFERENCE TO MAKE IN INDIA), ORDER 2017 DATED 19TH JULY, 2024 AND SUBSEQUENT ORDER(S)

(To be typed and submitted in the Letter Head of the Entity/Firm providing certificate as applicable)

Sub: Declaration reg. minimum local content in line with Public Procurement (Preference to Make in India), Order 2017-Revision, dated 04th June, 2020 and subsequent order(s).

Ref: 1) Bid Specification No:
2) All other pertinent issues till date

We hereby certify that the items/works/services offered by..... (*specify the name of the organization here*) has a local content of _____ % and this meets the local content requirement for '**Class-I local supplier**' / '**Class II local supplier**' ** as defined in Public Procurement (Preference to Make in India), Order 2017-Revision dated 04.06.2020 issued by DPIIT and subsequent order(s).

The details of the location(s) at which the local value addition is made are as follows:

- | | |
|----------|----------|
| 1. _____ | 2. _____ |
| 3. _____ | 4. _____ |

Thanking you,
Yours faithfully,

*(Signature, Date
& Seal of Authorized
Signatory of the Bidder)*

** - *Strike out whichever is not applicable.*

45. **PRE-QUALIFICATION REQUIREMENTS:**

APPLICATION:

This requirement is for Double Three Way Valve (DTWV), which is used in oil applications as change-over valve for Oil coolers in steam turbines. Double three-way valve is used for directing oil to the cooler in operation, while at the same time shutting off the flow in reserve oil cooler. The arrangement of these valves should be such that one hand wheel shall operate both three way valves together to establish in flow and out flow for one oil cooler. During changeover operation, outlet oil flow must not stop in any condition/position of the valve. The scope of supply shall include complete valve along with, flanges, gaskets, fasteners. General construction idea of the valve is given in fig. below. Two casing are arranged one over another and valves in these two casings are operated with a common hand wheel. A flow indicator on the valves body to indicate the direction of flow shall be provided. No intermediate position is required for operation. All three flanges of each casing should be in one plane as shown in figure.

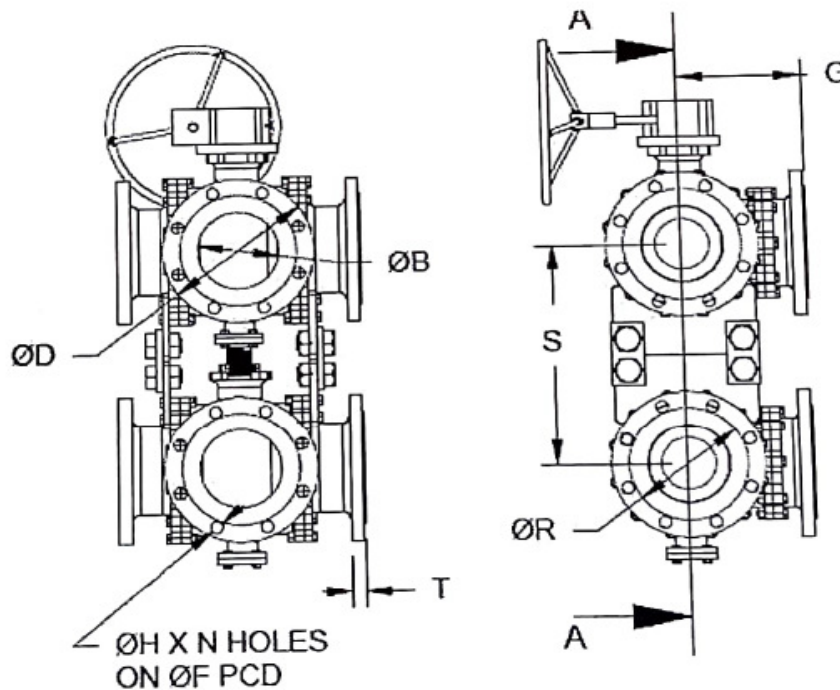



The Pre- Qualification Requirements pertaining to Engineering are as follows:

1. The Bidder should have successfully designed, manufactured, tested & supplied of DOUBLE THREE-WAY VALVE for water/oil application. Vendor should have supplied one (1) no. in at least one power/process plants in last seven (7) years from the date of issuance of enquiry with following technical details mentioned in table-1.

Table-1

Type:	DOUBLE THREE-WAY VALVE
Size Range:	NB100 & above
Rating:	CL150 & above
Body Material	Carbon Steel & above grade

2. The Bidder shall furnish the following documents in line with criteria given in above SL. NO.1 TABLE-1.
 - a. Executed Purchase order (P.O.) which should not be older than seven (7) years from the date of issuance of enquiry.
 - b. Approved GA drawing.
 - c. Dispatch document w.r.t above executed P. O. i.e., Delivery challan, Tax invoice, Inspection report, Packing List, Lorry way bill etc. for our review.

Note: -

1. BHEL reserves the right to verify the information submitted by vendor. Submission of false/incorrect information shall lead to rejection of offer and shall be taken seriously by BHEL.
2. BHEL reserves the right to ask for more pertinent information /documents / clarifications. Vendor shall provide this information to BHEL in a timely manner so that project schedule doesn't hamper.
3. All the documents furnished to BHEL shall be in English language only. If the documents are not in English, then they must be accompanied with duly certified English translations of the same.

----End of PQR----

SPECIAL NOTE FOR BIDDER:

Following documents are an integral part of this tender enquiry and endorsed copies of these documents (duly signed and stamped on each page, as a token of acceptance) are to be uploaded along with offer on GEM portal.

1. Please submit signed & Stamped copy (each page) of duly filled of confirmation column of "BUYER ADDED BID SPECIFIC ADDITIONAL TERMS AND CONDITIONS" and its clause wise supporting documents where required.
2. Any other documents required to be submitted as per your offer.
3. In case of blank document of Annexure-A of Buyer's Specific Terms & Conditions will be endorsed and submitted by bidder then it shall be deemed acceptable.
4. Copy/Replica of Price schedule (without prices) mentioning "Quoted' in place of price along with your techno-commercial (Part-1) offer.

CHECK LIST

NOTE: - Suppliers are required to fill in the following details in their Letterhead and no column should be left blank

A	Name and Address of the Supplier		
B	GSTN No. the Supplier (Place of Execution of Contract / Purchase Order)		
C	Details of Contact person for this Tender	Name: Mr./ Ms. Designation: Telephone No: Mobile No: Email ID:	
D	EMD DETAILS		
E	DESCRIPTION	APPLICABILITY (BY BHEL)	ENCLOSE BY BIDDER
i.	Whether Pre - Qualification Criteria is understood and provided proper supporting documents.	Applicable/ Not Applicable	YES / NO
ii.	Whether all pages of the Tender documents are read and understood	Applicable/ Not Applicable	YES / NO
iii.	Audited Balance Sheet and profit & Loss Account for the last three years	Applicable/ Not Applicable	YES / NO
iv.	Copy of PAN Card & GST registration	Applicable/ Not Applicable	YES / NO
v.	Submission of MSE certificate as specified in Tender	Applicable/ Not Applicable	YES / NO
vi.	Offer forwarding letter / tender submission letter as per Annexure – 2	Applicable/ Not Applicable	YES / NO
vii.	Submission of Certificate of No Deviation as per Annexure – 3	Applicable/ Not Applicable	YES / NO
viii.	Declaration regarding Insolvency/ Liquidation/Bankruptcy Proceedings as per Annexure – 4	Applicable/ Not Applicable	YES / NO
ix.	Declaration by Authorized Signatory as per Annexure – 5	Applicable/ Not Applicable	YES / NO

x.	Declaration by Authorized Signatory regarding Authenticity of submitted Documents Annexure – 6	Applicable/ Not Applicable	YES / NO
xi.	Submission of Non-Disclosure Certificate as per Annexure – 7	Applicable/ Not Applicable	YES / NO
xii.	Submission of Integrity Pact as specified in Tender as per Annexure – 8	Applicable/ Not Applicable	YES / NO
xiii.	Declaration confirming knowledge about Site Conditions as per Annexure – 9	Applicable/ Not Applicable	YES / NO
xiv.	Declaration reg. Related Firms & their areas of Activities as per Annexure – 10	Applicable/ Not Applicable	YES / NO
xv.	Declaration for relation in BHEL as per Annexure – 11	Applicable/ Not Applicable	YES / NO
xvi.	Declaration reg. minimum local content in line with revised public procurement as per Annexure – 12	Applicable/ Not Applicable	YES / NO
xvii.	Declaration regarding compliance to Restrictions under Rule 144 (xi) of GFR 2017 as per Annexure – 13	Applicable/ Not Applicable	YES / NO
xviii.	Bank Account Details for E-Payment as per Annexure – 14	Applicable/ Not Applicable	YES / NO
xix.	Power of Attorney for submission of tender as per Annexure – 15	Applicable/ Not Applicable	YES / NO
xx.	Proforma of Bank Guarantee for Earnest Money as per Annexure – 16	Applicable/ Not Applicable	YES / NO
xxi.	Proforma of Bank Guarantee for Performance Security as per Annexure – 17	Applicable/ Not Applicable	YES / NO
xxii.	List of Consortium Bank as per Annexure – 18	Applicable/ Not Applicable	YES / NO
xxiii.	Declaration for treatment of cases regarding conflict of interest as per Annexure – 19	Applicable/ Not Applicable	YES / NO

NOTE: Strike off 'YES' or 'NO', as applicable. Tender not accompanied by the prescribed **above applicable documents** are liable to be summarily rejected.

DATE:

**Sign. of the AUTHORISED SIGNATORY
(With Name, Designation and Company seal)**

OFFER FORWARDING LETTER / TENDER SUBMISSION LETTER

(To be typed and submitted in the Letter Head of the Company/Firm of Bidder)

Offer Reference No:

Date:

To,

(Write Name & Address of Officer of BHEL inviting the Tender)

Dear Sir,

Sub: Submission of Offer against Tender Enquiry No:

Having examined the tender documents against your Tender Enquiry No. _____ dated _____ and having understood the provisions of the said tender documents and having thoroughly studied the requirements of BHEL related to the work tendered for, in connection with _____ (name of work & project site), we hereby submit our offer for the proposed work in accordance with terms and conditions mentioned in the tender documents, at the prices quoted by us and as per the indicated delivery schedule.

Should our Offer be accepted by BHEL for Award, I/we further agree to furnish 'Performance Security' for the work as provided for in the Tender Conditions within the stipulated time as may be indicated by BHEL.

I/We further agree to execute all the works referred to in the said Tender documents upon the terms and conditions contained or referred to therein and as detailed in the appendices annexed thereto.

I/We have deposited herewith the requisite Earnest Money Deposit (EMD) as per details furnished in the Check List.

Authorized Representative of Bidder

Signature:

Name:

Address:

Place:

Date:

CERTIFICATE OF NO DEVIATION

(To be Typed & submitted in the Letter Head of the Company/Firm of Bidder)

To,

(Write Name & Address of Officer of BHEL inviting the Tender)

Dear Sir,

Subject: **No Deviation Certificate**

Ref: 1) Tender Enquiry No:,
2) All other pertinent issues till date

We hereby confirm that we have not changed/ modified/materially altered any of the tender documents as downloaded from the website/ issued by BHEL and in case of such observance at any stage, it shall be treated as null and void.

We also hereby confirm that we have neither set any Terms and Conditions and nor have we taken any deviation from the Tender conditions together with other references applicable for the above referred Tender Enquiry.

We further confirm our unqualified acceptance to all Terms and Conditions, unqualified compliance to Tender Conditions.

We confirm to have submitted offer in accordance with tender instructions and as per aforesaid references.

Thanking you,

Yours faithfully,

**(Signature, date & seal of authorized
representative of the bidder)**

Date:

Place:

UNDERTAKING

(To be typed and submitted in the Letter Head of the Company/Firm of Bidder)

To,

(Write Name & Address of Officer of BHEL inviting the Tender)

Dear Sir/Madam,

Sub: DECLARATION REGARDING INSOLVENCY/ LIQUIDATION/ BANKRUPTCY PROCEEDINGS

Ref: Tender Enquiry Specification No:

I/We, _____ declare that,

I/We am/are not admitted under insolvency resolution process or liquidation under Insolvency and Bankruptcy Code, 2016, as amended from time to time or under any other law as on date, by NCLT or any adjudicating authority/authorities.

**Sign. of the AUTHORISED SIGNATORY
(With Name, Designation and Company seal)**

Place:

Date:

DECLARATION BY AUTHORISED SIGNATORY OF BIDDER

(To be typed and submitted in the Letter Head of the Company/Firm of Bidder)

To,

(Write Name & Address of Officer of BHEL inviting the Tender)

Dear Sir,

Sub: **Declaration by Authorised Signatory**

Ref: 1) Tender Enquiry Specification No:

2) All other pertinent issues till date

I/We, hereby certify that all the information and data furnished by me with regard to the above Tender Specification are true and complete to the best of my knowledge. I have gone through the specifications, conditions, stipulations and all other pertinent issues till date, and agree to comply with the requirements and Intent of the specification.

I further certify that I am authorized to represent on behalf of my Company/Firm for the above-mentioned tender and a valid Power of Attorney to this effect is also enclosed.

Yours faithfully,

(Signature, Date & Seal of Authorized
Signatory of the Bidder)

Date:

Enclosed: Power of Attorney

DECLARATION BY AUTHORISED SIGNATORY OF BIDDER

(To be typed and submitted in the Letter Head of the Company/Firm of Bidder)

To,

(Write Name & Address of Officer of BHEL inviting the Tender)

Dear Sir,

Sub : **Declaration by Authorised Signatory regarding Authenticity of submitted documents.**

Ref : 1) Tender Enquiry No. & Date:

2) All other pertinent issues till date

I/We, hereby certify that all the documents submitted by us in support of possession of "Qualifying Requirements" are true copies of the original and are fully compliant required for qualifying / applying in the bid and shall produce the original of same as and when required by Bharat Heavy Electricals Limited.

I / We hereby further confirm that no tampering is done with documents submitted in support of our qualification as bidder. I / We understand that at any stage (during bidding process or while executing the awarded contract) if it is found that fake / false / forged bid qualifying / supporting documents / certificates were submitted, it would lead to summarily rejection of our bid / termination of contract. BHEL shall be at liberty to initiate other appropriate actions as per the terms of the Bid / Contract and other extant policies of Bharat Heavy Electricals Limited.

Yours faithfully,

**(Signature, Date & Seal of Authorized
Signatory of the Bidder)**

Date:

DECLARATION

Date: _____

To,

(Write Name & Address of Officer of BHEL inviting the Tender)

Dear Sir/ Madam,

Sub: **Details of related firms and their area of activities**

Please find below details of firms owned by our family members that are doing business/ registered for same item with BHEL, _____ (NA, if not applicable)

1	Material Category/ Work Description	
	Name of Firm	
	Address of Firm	
	Nature of Business	
	Name of Family Member	
	Relationship	
2	Material Category/ Work Description	
	Name of Firm	
	Address of Firm	
	Nature of Business	
	Name of Family Member	
	Relationship	
...		

Note: I certify that the above information is true and I agree for penal action from BHEL in case any of the above information furnished is found to be false.

Regards,

(_____)

From: M/s _____

Supplier Code: _____

Address: _____

DECLARATION FOR RELATION IN BHEL

(To be typed and submitted in the Letter Head of the Company/Firm of Bidder failing which the offer of Bidder is liable to be summarily rejected)

To,

(Write Name & Address of Officer of BHEL inviting the Tender)

Dear Sir,

Sub: Declaration for relation in BHEL

Ref: 1) Tender Enquiry Specification No:

I/We hereby submit the following information pertaining to relation/relatives of Proprieter/Partner(s)/ Director(s) employed in BHEL

Tick (√) any one as applicable:

1. The Proprieter, Partner(s), Director(s) of our Company/Firm DO NOT have any relation or relatives employed in BHEL

OR

2. The Proprieter, Partner(s), or Director(s) of our Company/Firm HAVE relation/relatives employed in BHEL and their particulars are as below:

i.

ii

.

(Signature, Date & Seal of Authorized Signatory of the Bidder)

Note:

1. Attach separate sheet, if necessary.
2. If BHEL Management comes to know at a later date that the information furnished by the Bidder is false, BHEL reserves the right to take suitable against the Bidder/Contractor.

**DECLARATION REGARDING MINIMUM LOCAL CONTENT IN LINE WITH
REVISED PUBLIC PROCUREMENT (PREFERENCE TO MAKE IN INDIA), ORDER 2017 DATED 19TH
JULY, 2024 AND SUBSEQUENT ORDER(S)**

(To be typed and submitted in the Letter Head of the Entity/Firm providing certificate as applicable)

To,

(Write Name & Address of Officer of BHEL inviting the Tender)

Dear Sir,

Sub: Declaration reg. minimum local content in line with Public Procurement (Preference to Make in India), Order 2017-Revision, dated 19th July, 2024 and subsequent order(s).

Ref: 1) Tender Enquiry Specification No:
2) All other pertinent issues till date

We hereby certify that the items/works/services offered by..... (*specify the name of the organization here*) has a local content of _____ % and this meets the local content requirement for '**Class-I local supplier**' / '**Class II local supplier**' ** as defined in Public Procurement (Preference to Make in India), Order 2017-Revision dated 04.06.2020 issued by DPIIT and subsequent order(s).

The details of the location(s) at which the local value addition is made are as follows:

1. _____ 2. _____

3. _____ 4. _____

...

Thanking you,
Yours faithfully,

**(Signature, Date & Seal of
Authorized Signatory of the Bidder)**

**** - Strike out whichever is not applicable.**

Note:

1. Bidders to note that above format, duly filled & signed by authorized signatory, shall be submitted along with the techno-commercial offer.
2. In case the bidder's quoted value is in excess of Rs. 10 crores, the authorized signatory for this declaration shall necessarily be the statutory auditor or cost auditor of the company (in the case of companies) or a practising cost accountant or practicing chartered accountant (in respect of suppliers other than companies).
3. In the event of false declaration, actions as per the above order and as per BHEL Guidelines shall be initiated against the bidder.

DECLARATION REGARDING COMPLIANCE TO RESTRICTIONS UNDER RULE 144 (xi) OF GFR 2017

(To be typed and submitted in the Letter Head of the Entity/ Firm providing certificate as applicable)

To,

(Write Name & Address of Officer of BHEL inviting the Tender)

Dear Sir,

Sub: Declaration regarding compliance to Restrictions under Rule 144 (xi) of GFR 2017

Ref: 1) Tender Enquiry Specification No:
2) All other pertinent issues till date

I have read the clause regarding restrictions on procurement from a bidder of a country which shares a land border with India. I certify that _____ (**SPECIFY THE NAME OF THE ORGANIZATION HERE**), is not from such a country/ has been registered with the Competent Authority (*attach valid registration by the Competent Authority, i.e., the Registration Committee constituted by the Dept. for Promotion of Industry and Internal Trade (DPIIT).*)

I hereby certify that we fulfil all requirements in this regard and is eligible to be considered.

Thanking you,
Yours faithfully,

**(Signature, Date & Seal of
Authorized Signatory of the Bidder)**

Note: Bidders to note that in case above certification given by a bidder, whose bid is accepted, is found to be false, then this would be a ground for immediate termination and for taking further action in accordance with law and as per BHEL guidelines.

Declaration for treatment of cases regarding conflict of interest

(To be typed and submitted in the Letter Head of the Company/Firm of Bidder)

To,

(Write Name & Address of Officer of BHEL inviting the Tender)

Dear Sir,

Sub: Declaration for treatment of cases regarding conflict of interest

Ref: Tender Reference No:

The bidder notes that a conflict of interest would said to have occurred in the tender process and execution of the resultant contract, in case of any of the following situations:

- i. If its personnel have a close personal, financial, or business relationship with any personnel of BHEL who are directly or indirectly related to the procurement or execution process of the contract, which can affect the decision of BHEL directly or indirectly;
- ii. The bidder (or his allied firm) provided services for the need assessment/ procurement planning of the Tender process in which it is participating;
- iii. Procurement of goods directly from the manufacturers/suppliers shall be preferred. However, if the OEM/Principal insists on engaging the services of an agent, such agent shall not be allowed to represent more than one manufacturer/ supplier in the same tender. Moreover, either the agent could bid on behalf of the manufacturer/ supplier or the manufacturer/ supplier could bid directly but not both. In case bids are received from both the manufacturer/ supplier and the agent, bid received from the agent shall be ignored. However, this shall not debar more than one Authorized distributor (with/ or without the OEM) from quoting equipment manufactured by an Original Equipment Manufacturer (OEM) in procurements under a Proprietary Article Certificate.
- iv. A bidder participates in more than one bid in this tender process. Participation in any capacity by a Bidder (including the participation of a Bidder as a partner/ JV member or sub-contractor in another bid or vice-versa) in more than one bid shall result in the disqualification of all bids in which he is a party. However, this does not limit the participation of an entity as a sub-contractor in more than one bid if he is not bidding independently in his own name or as a member of a JV.

The Bidder declares that they have read and understood the above aspects, and the bidder confirms that such conflict of interest does not exist and undertakes that they will not enter into any illegal or undisclosed agreement or understanding, whether formal or informal with other Bidder(s), in this regard. This applies in particular to prices, specifications, certifications, subsidiary contracts, submission or non-submission of bids or any other actions to restrict competitiveness or to introduce cartelization in the bidding process.

In case, the Bidder is found having indulged in above activities, the same will be considered as a violation of the tender conditions, and suitable action shall be taken by BHEL as per extant policies/ guidelines.

(Signature of the authorized signatory of the bidder)



**PRE-QUALIFICATION REQUIREMENT
DOUBLE THREE-WAY VALVE**

DOCUMENT NO.
STE-TL/DTWV/PQR/2024001
Rev:00 Dt:12.06.2024

APPLICATION:

This requirement is for Double Three Way Valve (DTWV), which is used in oil applications as change-over valve for Oil coolers in steam turbines. Double three-way valve is used for directing oil to the cooler in operation, while at the same time shutting off the flow in reserve oil cooler. The arrangement of these valves should be such that one hand wheel shall operate both three way valves together to establish in flow and out flow for one oil cooler. During changeover operation, outlet oil flow must not stop in any condition/position of the valve. The scope of supply shall include complete valve along with, flanges, gaskets, fasteners. General construction idea of the valve is given in fig. below. Two casing are arranged one over another and valves in these two casings are operated with a common hand wheel. A flow indicator on the valves body to indicate the direction of flow shall be provided. No intermediate position is required for operation. All three flanges of each casing should be in one plane as shown in figure.

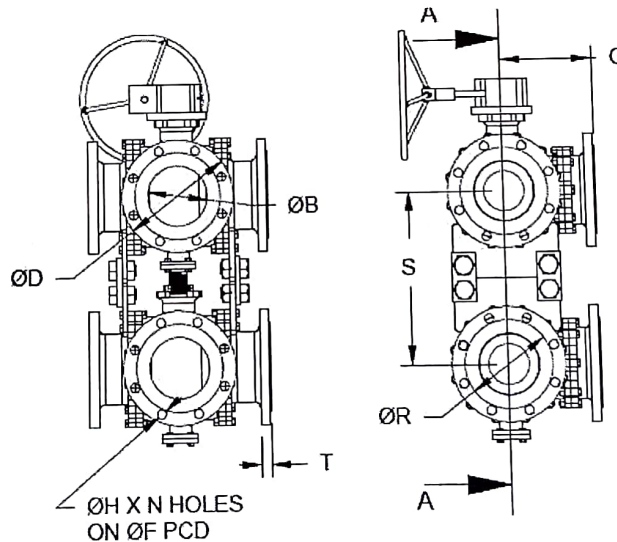

Prepared By <i>Sunil Kr. Sharma</i> SUNIL KR. SHARMA Engineer/STE-TL	Checked BY <i>Nilesh Kumar</i> NILESH KUMAR Manager/STE-TL	Approved By <i>S.K. Sonkar</i> S.K. SONKAR DGM/STE-TL
---	---	--



BHARAT HEAVY ELECTRICALS LIMITED, HARIDWAR
STE-TL ENGINEERING DEPARTMENT

**PRE-QUALIFICATION REQUIREMENT
DOUBLE THREE-WAY VALVE**

DOCUMENT NO.
STE-TL/DTWV/PQR/2024001
Rev:00 Dt:12.06.2024

The Pre- Qualification Requirements pertaining to Engineering are as follows:

1. The Bidder should have successfully designed, manufactured, tested & supplied of DOUBLE THREE-WAY VALVE for water/oil application. Vendor should have supplied one (1) no. in at least one power/process plants in last seven (7) years from the date of issuance of enquiry with following technical details mentioned in table-1.

Table-1

Type:	DOUBLE THREE-WAY VALVE
Size Range:	NB100 & above
Rating:	CL150 & above
Body Material	Carbon Steel & above grade

2. The Bidder shall furnish the following documents in line with criteria given in above SL. NO.1 TABLE-1.
 - a. Executed Purchase order (P.O.) which should not be older than seven (7) years from the date of issuance of enquiry.
 - b. Approved GA drawing.
 - c. Dispatch document w.r.t above executed P. O. i.e., Delivery challan, Tax invoice, Inspection report, Packing List, Lorry way bill etc. for our review.

Note: -

1. BHEL reserves the right to verify the information submitted by vendor. Submission of false/incorrect information shall lead to rejection of offer and shall be taken seriously by BHEL.
2. BHEL reserves the right to ask for more pertinent information /documents / clarifications. Vendor shall provide this information to BHEL in a timely manner so that project schedule doesn't hamper.
3. All the documents furnished to BHEL shall be in English language only. If the documents are not in English, then they must be accompanied with duly certified English translations of the same.

----End of PQR----

Page 2 of 2

Prepared By SUNIL KR. SHARMA Engineer/STE-TL	Checked BY NILESH KUMAR Manager/STE-TL	Approved By S.K. SONKAR DGM/STE-TL
--	--	--



उत्पाद मानक

ST- 47028

PRODUCT STANDARD
(STEAM TURBINE ENGINEERING)

पृष्ठ 03 का 01

Page 01 of 03

TECHNICAL SPECIFICATION FOR DOUBLE THREE WAY VALVE

1.0 SCOPE :-

- 1.1 The specification covers design, manufacturing, assembly, testing and supply of double three way valves, details as per table-1.
- 1.2 One set of all rubber (VITON) seals as commissioning spares.

TABLE-1:

SL. NO.	SIZE NB (mm)				MEDIUM	WORKING PARAMETER	BODY MATERIAL
	VAR. 01	VAR. 02	VAR. 03	VAR. 04			
01	125	200	150	100	TURBINE OIL VG46	12 Kg/cm ² 65°C	CARBON STEEL OR GGG40
02	200	150			FIRE RESISTANT FLUID (PHOSPHATE ESTER)	1 Kg/cm ² 55°C	CARBON STEEL
03	100				-DO-	12 Kg/cm ² 55°C	STAINLESS STEEL

2.0 FUNCTION:-The oil/Fire Resistant Fluid is cooled in oil cooler before it flows into the system.

Double three way valve is used for directing oil/Fire Resistant Fluid to the cooler in operation, while at the same time shutting off the flow in reserve oil cooler. The arrangement of these valves should be such that one hand wheel shall operate both three way valves to establish in flow and out flow for one oil/ Fire Resistant Fluid cooler.

3.0 CONSTRUCTION: - A general construction idea of the valve is given in fig. on page no-3. Two casing are arranged one over another and valves in these two casings are operated with a common hand wheel . A flow indicator on the valves body to indicate the direction of flow shall be provided. No intermediate position is required for operation. All three flanges of each casing should be in one plane as shown on page no-3.

4.0 MATERIAL :- Body- Refer table-1
Packing-VITON
Material of internals to be stainless steel.

5.0 END CONNECTION: - Flange as per rating PN 16 DIN 2633.

6.0 INSTALLATION: - In horizontal pipe lines, valve in vertical position.

अनुमोदक एवं हस्ताक्षर
SIGN & DATE

SUPERSEDES
INVENTORY NO.

सामग्री सूची संख्या को
अधिकृत करता है

COPYRIGHT AND CONFIDENTIAL
The information on this documents is the property of Bharat Heavy Electrical Limited. It must not be used directly or indirectly in any way detrimental to the interest of the company

स्वत्वाधिकार एवं गोपनीय
इस प्रलेख में दी गई सूचना भारत हेवी इलेक्ट्रिकल्स की संपत्ति है इसका प्रयोग एवं आरम्भ रूप से किसी भी तरह प्रयोग, जो कि कंपनी के हित में हानिकारक हो न किया जाए।

अनुमोदक एवं दिनांक
SIGN & DATE

सामग्री सूची संख्या
INVENTORY NO.

				नाम NAME	दिनांक एवं हस्ताक्षर SIGNATURE & DATE
TSX	LALIT KUMAR	Lalit Kumar	अनुवादक TRANSLATED BY	-	
MEMBER PSC	R.PANJA	R.PANJA	निर्माककर्ता WORKED BY	VIVEK RAWAT	Vivek Rawat
सहमत विभाग AGREED DEPTT.	नाम NAME	दिनांक एवं हस्ताक्षर DATE & SIGNATURE	जांचकर्ता CHECKED BY	A.KUMAR	Ashok
			पर्यवेक्षणकर्ता SUPERVISED BY	ANUJ JAIN	Anuj Jain
(SUPERSEDES)			स्वीकृति APPROVED :	(A.B.GUPTA) AGM	GR. No. 3-50
REV.NO. 07			निर्माण PREPARED :	PEP	DATE: 26.03. 84
Dt. 15.03.13			जारी ISSUED :	PEP	

उत्पाद मानक

PRODUCT STANDARD
 (STEAM TURBINE ENGINEERING)

 दिनांक एवं हस्ताक्षर
 SIGN & DATE

 SUPERSEDES
 INVENTORY

 सामग्री सूची संख्या को
 अतिरिक्तित करता है

COPYRIGHT AND CONFIDENTIAL
 The information on this document is the property of Bharat Heavy Electrical Limited. It must not be used directly or indirectly in any way detrimental to the interest of the company

स्वत्वाधिकार एवं गोपनीय
 इस प्रलेख में दी गई सूचना भारत हेवी इलेक्ट्रिकल्स की संपत्ति है इसका प्रकाश एवं आरक्षण रूप से किसी भी तरह प्रयोग, जो कि कंपनी के हित में हानिकारक हो न किया जाए।

 हस्ताक्षर एवं दिनांक
 SIGN & DATE

 सामग्री सूची संख्या
 INVENTORY NO.

- 7.0 The bidder shall furnish Quality Plan in specified format. However the min. test requirement envisaged by BHEL are as follows :
- 7.1 **Testing of Materials :-** The material of components of valve such as body, bonnet, stem & fasteners shall be tested as per relevant specification for its chemical composition & mechanical properties. For remaining components compliance certificate shall be furnished.
- 7.2 DPT on body, stem & seat and all welded joints.
- 7.3 Color matching of valve seat & plug in case of metal contact.
- 7.4 Function test. (Functional test to be furnished by vendor with offer for BHEL's approval)
- 7.5 All welding to be carried out as per qualified procedures and welders in according with ASME Sec. IX.
- 7.6 Hydraulic test at 1.5 times the design pressure.
- 7.7 **Seat leakage test:** - It shall be carried out at 1.1 times of the design pressure for 5 minutes. Acceptance norms shall be NIL leakage as per class rate 'A' of standard EN12266.

8.0 Painting Scheme :-

Paint (Cost)	Paint Type	No. of coat	DFT*
Primer Paint	Epoxy base Zinc rich primer paint	2 Coats	70
Intermediate Paint	Epoxy TiO ₂ Pigmented Polyamide Cured Paint	1 Coat	70
Finish (Final) Paint	Aliphatic Acrylic 2 Pack Polyurethane finish paint	2 Coats	60
Shade as per IS:5 or Equivalent	Smoke Grey ISC 692		
		Total	DFT 180

***DFT-Dry Film Thickness (Final) in microns.**
Color shade may be changed during execution of contract.

- 9.0 **GUARANTEE :-** The supplier shall guarantee trouble free and satisfactory operation of the equipment for a period of 18 months after delivery or 12 months after commissioning which ever is earlier.

REV. NO.

07

(SUPERSEDES

 निर्माणकर्ता
 WORKED BY

A.KUMAR

 जांचकर्ता
 CHECKED BY

ANUJ JAIN

16/3/13

16/3/13



उत्पाद मानक

PRODUCT STANDARD
(STEAM TURBINE ENGINEERING)

ST- 47028

पृष्ठ 03 का 03

Page 03 of 03

दिनांक एवं हस्ताक्षर
SIGN & DATE

SUPERSEDES
INVENTORY

सामग्री सूची संख्या को
अधिकृतित करता है

COPYRIGHT AND CONFIDENTIAL
The information on this documents is the property of Bharat Heavy Electrical Limited. It must not be used directly or indirectly in any way detrimental to the interest of the company

स्वत्साधिकार एवं गोपनीय
हर प्रलेख में दी गई सूचना भारत हेवी इलेक्ट्रिकल्स की संपत्ति है इसका प्रत्यक्ष एवं अप्रत्यक्ष रूप से किसी भी तरह प्रयोग, जो कि कंपनी के हित में हानिकारक हो न किया जाए।

हस्ताक्षर एवं दिनांक
SIGN & DATE

सामग्री सूची संख्या
INVENTORY NO.

10.0 DOCUMENT

10.1 DOCUMENTS REQUIRED ALONG WITH OFFER-

Acts of following documents in English language -

- (i) Cross sectional and dimensional drawing along with Bill Of Material and end connection details.
- (ii) Quality Plan.
- (iii) List of spares for 3 years of operation

10.2 DOCUMENTS AFTER PLACEMENT OF ORDER

- (i) Four copies of finalized contract drawings-within four weeks of placement of order.
- (ii) Ten copies of operation and maintenance instructions-within 12 weeks of placement of order.
- (iii) Six copies of test certificates.

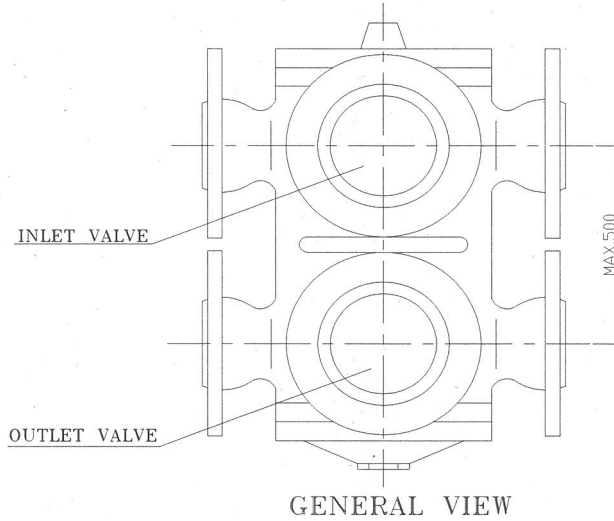

Cross referred standard:- ASME sec. IX

DIN 2633

IS: 5

ISC 692

EN 12266

REV. NO.

07

(SUPERSEDES)

निर्माणकर्ता
WORKED BY

A.KUMAR

जांचकर्ता
CHECKED BY

ANUJ JAIN

Aslok

16/3/13

Anuj

16/3/13

16/3/13

P-5579

MANUFACTURER'S NAME AND ADDRESS		STANDARD QUALITY PLAN				TO BE FILLED BY BHEL		TO BE FILLED BY BHEL				
BHEL	VENDOR'S NAME	ITEM	DOUBLE THREE-WAY VALVE		QP NO.	QA_BI_QP_101, REV02						
		DRG. NO.		AS PER PO								
		SPEC.		AS PER PO								
		REV		AS PER PO				Page 1 of 3				
SL. NO.	COMPONENT & OPERATIONS	CHARACTERISTICS	CLASS	TYPE OF CHECK	QUANTUM OF CHECK	REFERENCE DOCUMENT	ACCEPTANCE NORMS	FORMAT OF RECORDS		AGENCY		REMARKS
1	2	3	4	5	6	7	8	9	D	10	11	

1	GENERAL	QUALIFICATION WELDING PROCEDURE, WELDER, TESTING FACILITY	MAJOR	VISUAL	100%				√	P	V	-	SUB-VENDORS CERTIFICATE& SUPPORTING DOCUMENTS
2	CHANGE-OVER HOUSING	CHEMICAL ANALYSIS	MAJOR	CHEMICAL	100%	APPROVED DRAWING / DATA SHEET		TC	√	V	V	-	
		MECHANICAL PROPERTIES	MAJOR	MECHANICAL	100%			TC	√	V	V	-	
		D.P TEST OR ULTRASONIC TEST	MAJOR	NDT	100%			TC	√	V	V	-	
		DIMENSION	MAJOR	MEASUREMENT	100%			TC		V	-	-	
3	BALL	CHEMICAL ANALYSIS	MAJOR	CHEMICAL	100%	APPROVED DRAWING / DATA SHEET		TC	√	V	V	-	
		MECHANICAL PROPERTIES	MAJOR	MECHANICAL	100%			TC	√	V	V	-	
		DIMENSION	MAJOR	MEASUREMENT	100%			TC		V	-	-	
4	SPINDLE	CHEMICAL ANALYSIS	MAJOR	CHEMICAL	100%	APPROVED DRAWING / DATA SHEET		TC	√	V	V	-	
		MECHANICAL PROPERTIES	MAJOR	MECHANICAL	100%			TC	√	V	V	-	
		DIMENSION	MAJOR	MEASUREMENT	100%			TC		V	-	-	
5	FLANGE	CHEMICAL ANALYSIS	MAJOR	CHEMICAL	100%	APPROVED DRAWING / DATA SHEET		TC	√	V	V	-	
		MECHANICAL PROPERTIES	MAJOR	MECHANICAL	100%			TC	√	V	V	-	
		DIMENSION	MAJOR	MEASUREMENT	100%			TC		V	-	-	

		LEGEND: ! RECORDS IDENTIFIED WITH 'TICK' SHALL BE ESSENTIALLY INCLUDED BY CONTRACTOR IN QA DOCUMENTATION. M: MANUFACTURER / SUBCONTRACTOR B: BHEL / NOM. INSPECTION AGENCY N: CUSTOMER INDICATE 'P' PERFORM 'W' WITNESS AND 'V' VERIFICATION ALL 'W' INDICATED IN COLUMN 'N' SHALL BE 'CHP' OF CUSTOMER	FOR CUSTOMER USE	
MANUFACTURER/SUBCONTRACTOR				APPROVED BY

MANUFACTURER'S NAME AND ADDRESS		STANDARD QUALITY PLAN				TO BE FILLED BY BHEL		TO BE FILLED BY BHEL				
BHEL	VENDOR'S NAME	ITEM	DOUBLE THREE-WAY VALVE		QP NO.	QA_BI_QP_101, REV02						
				DATED	28.11.2025							
		DRG. NO.	AS PER PO									
		SPEC.	AS PER PO									
REV	AS PER PO				Page 2 of 3							
SL. NO.	COMPONENT & OPERATIONS	CHARACTERISTICS	CLASS	TYPE OF CHECK	QUANTUM OF CHECK	REFERENCE DOCUMENT	ACCEPTANCE NORMS	FORMAT OF RECORDS		AGENCY		REMARKS
1	2	3	4	5	6	7	8	9	D	10		11

6	PIPE	CHEMICAL ANALYSIS	MAJOR	CHEMICAL	100%	APPROVED DRAWING / DATA SHEET / SPECIFICATION	TC	√	V	V	-		
		MECHANICAL PROPERTIES	MAJOR	MECHANICAL	100%		TC	√	V	V	-		
		DIMENSION	MAJOR	MEASUREMENT	100%		TC		V	-	-		
7	HEX-BOLTS	CHEMICAL ANALYSIS	MAJOR	CHEMICAL	100%	APPROVED DRAWING / DATA SHEET / SPECIFICATION	TC	√	V	V	-		
		MECHANICAL PROPERTIES	MAJOR	MECHANICAL	100%		TC	√	V	V	-		
		DIMENSION	MAJOR	MEASUREMENT	100%		TC		V	-	-		
8	CHANGE-OVER VALVE'S FLANGE ASSEMBLY (WELDING)	DIMENSION	MAJOR	MEASUREMENT	100%	APPROVE DRAWING	INSPECTION REPORT		P	-	-		
		D.P.TEST	MAJOR	DPT	100%	VENDOR SPECIFICATION	COC	√	P	V	-		
9	CHANGE OVER VALVE ASSEMBLY	DIMENSION	MAJOR	MEASUREMENT	100%	APPROVE DRAWING	TC	√	P	W	-		
		SEAT LEAKAGE TEST (time 5 minutes)	MAJOR	LEAKAGE TEST	100%	VENDORS TENDOR	APPROVED DRAWING / DATA SHEET / SPECIFICATION	TC	√	P	W	-	
		FUNCTIONAL TEST TO CHECK SMOOTH OPENING / CLOSING	MAJOR	VISUAL	100%	VENDORS TENDOR	APPROVED DRAWING / DATA SHEET / SPECIFICATION	TC	√	P	W	-	

		LEGEND: ! RECORDS IDENTIFIED WITH 'TICK' SHALL BE ESSENTIALLY INCLUDED BY CONTRACTOR IN QA DOCUMENTATION. M: MANUFACTURER / SUBCONTRACTOR B: BHEL / NOM. INSPECTION AGENCY N: CUSTOMER INDICATE 'P' PERFORM 'W' WITNESS AND 'V' VERIFICATION ALL 'W' INDICATED IN COLUMN 'N' SHALL BE 'CHP' OF CUSTOMER	FOR CUSTOMER USE	
MANUFACTURER/SUBCONTRACTOR				APPROVED BY

MANUFACTURER'S NAME AND ADDRESS		STANDARD QUALITY PLAN				TO BE FILLED BY BHEL		TO BE FILLED BY BHEL				
BHEL	VENDOR'S NAME	ITEM	DOUBLE THREE-WAY VALVE		QP NO.	QA_BI_QP_101, REV02						
				DATED	28.11.2025							
		DRG. NO.	AS PER PO									
		SPEC.	AS PER PO									
SL. NO.	COMPONENT & OPERATIONS	CHARACTERISTICS	CLASS	TYPE OF CHECK	QUANTUM OF CHECK	REFERENCE DOCUMENT	ACCEPTANCE NORMS	FORMAT OF RECORDS	AGENCY			REMARKS
1	2	3	4	5	6	7	8	9	D	10		11

		HYDRO STATIC TEST (1.5 TIMES OF WORKING PRESSURE FOR 30 MINUTES)	MAJOR	HYDRAULIC TEST	100%	VENDORS TENDOR	APPROVED DRAWING / DATA SHEET / SPECIFICATION	TC	v	P	W	-	
		PAINTING (AS APPLICABLE)	MAJOR	VISUAL	100%	VENDORS TENDOR	APPROVED DRAWING / DATA SHEET / SPECIFICATION	TC	v	P	W	-	

NOTE:

1. COLOR MACTHING IS REQUIRED IF THERE IS METAL TO METAL CONTACT BETWEEN BALL AND SEAL CUP.
2. TEST CERTIFICATES SHALL BE SUBMITTED QP CLAUSE WISE MENTIONING CLAUSE NO. ON EACH PAGE.
3. CALIBRATED INSTRUMENTS WITH VALID CALIBRATION CERTIFICATE SHALL BE USED TO TESTING. INSPECTOR WILL CHECK THE CERTIFICATE BEFORE TESTING.

		LEGEND: ! RECORDS IDENTIFIED WITH 'TICK' SHALL BE ESSENTIALLY INCLUDED BY CONTRACTOR IN QA DOCUMENTATION. M: MANUFACTURER / SUBCONTRACTOR B: BHEL / NOM. INSPECTION AGENCY N: CUSTOMER INDICATE 'P' PERFORM 'W' WITNESS AND 'V' VERIFICATION ALL 'W' INDICATED IN COLUMN 'N' SHALL BE 'CHP' OF CUSTOMER	FOR CUSTOMER USE	
MANUFACTURER/SUBCONTRACTOR				APPROVED BY