



**Bharat Heavy Electricals Limited**  
Industrial Valves Plant  
Goindwal Sahib (Punjab)

**Enquiry No.**  
**2324-038E**

**Date:**  
**05.08.2023**

**NOTICE INVITING TENDER (NIT)**

Dear Sir / Madam,

BHEL Goindwal Sahib (Punjab) invites offers from interested bidders / suppliers for submission of their offer through e-procurement mode at <https://eprocurebhel.co.in/>. Offers in any other mode will not be accepted. In case of any difficulty faced while registering on BHEL's e-Procurement portal developed by NIC, queries may be addressed to 0120-4001002, 0120-4001005 and 0120-6277787; email: [support-eproc@nic.in](mailto:support-eproc@nic.in). These details are also available on 'Contact Us' page of the portal.

<b>Tender enquiry no. &amp; date</b>	2324-038E dated 05.08.2023
<b>Form of contract</b>	Supply
<b>Tender / Item description</b>	Foundation Bolts (Including Nuts and Washers)
<b>Material standard / Drawings</b>	As per attached Drawings
<b>Location(s) of Supply / Work</b>	NTPC Talcher, Distt. Angul, Odisha, India – 759107.
<b>Unloading of Material</b>	At NTPC Talcher Site by BHEL Site.
<b>Earnest Money Deposit (EMD)</b>	Not Applicable
<b>Quotation parts</b>	Two Part Bid
<b>Tender download / Bid submission start date</b>	<b>05.08.2023 (15:00 Hrs. IST)</b>
<b>Tender download / Bid submission end date</b>	<b>16.08.2023 (12:00 Hrs. IST)</b>
<b>Tender / Bid opening date</b>	<b>16.08.2023 (15:30 Hrs. IST)</b>
<b>Validity of offer (In days)</b>	70 days from techno commercial bid opening (Part I)
<b>Quantity variation</b>	+/- 10% of tender quantity
<b>Delivery schedule</b>	Within 75 days from the date of PO placement / LOI
<b>Tender evaluation</b>	Item - Wise
<b>Reverse auction</b>	Applicable
<b>Contact person details</b>	Sumeet Bansal, Sr. Manager 01859-224 628, <a href="mailto:sbansal@bhel.in">sbansal@bhel.in</a>  Pranshu, Dy. Manager 01859-224 685, <a href="mailto:pranshu@bhel.in">pranshu@bhel.in</a>

**PART-I (TECHNO-COMMERCIAL BID)**

(To be filled by bidder &amp; submit with offer as pdf file only)

**Tender Enquiry No. & Date****2324-038E Dt. 05.08.2023****Tender Description****Supply of Foundation Bolts**

Bidder must note following points:

1. This workbook is protected, except for cells where comments / confirmation is to be given by bidder.
2. Bidder is advised not to unprotect / tamper the sheet / alter the terms mentioned in the sheet.
3. Any alteration to terms mentioned by BHEL will be considered as tampering and bidder's offer shall be liable for rejection.
4. Bidders are advised to only fill the unprotected cells (shaded cells) by dropdown or writing the comments as applicable as their confirmation. **Bidders are advised to submit duly filled & signed 'PDF' file as techno-commercial (Part-I) bid**. Failure on the part of bidder in not returning this duly filled-up techno-commercial bid and / or submitting incomplete replies may lead to rejection of bidder's quotation.
5. All the commercial terms and conditions shall be indicated by vendor in this format only and nowhere else in his quotation. However, in case the space for vendor's reply is not sufficient against a particular question, the vendor shall furnish same by way of separate annexure / sheet attached to this questionnaire, indicating cross-reference of respective clauses.

**BIDDER'S DETAILS**

Sr. No.	Elements	Remarks
1	Bidder's Name/Name of the Firm	
2	Quotation reference no. & date	
3	Contact Person Name/Number/Designation	Name: Contact No: Designation:
4	Email ID (s)-(Can be provided more than one)	
5	Mobile No. (s)	
6	Tel. No. (s)	
7	Fax No.	
8	Registered Address	
9	Address for Correspondence	
10	Bidder Type (Indian / Foreign):	
11	Company's Establishment Year	
12	Company's Nature of Business (Tick the relevant option <input type="checkbox"/> )	<input type="checkbox"/> Manufacturer <input type="checkbox"/> Dealer/ Trader/ Stockist/Channel Partner/Agent/etc.
13	Company Category (Micro unit as per MSME / Small unit as per MSME /	
14	Status of the Company / Firm * (Relevant documents must be enclosed) (Tick the relevant option <input type="checkbox"/> )	<input type="checkbox"/> Public Limited; <input type="checkbox"/> Private Limited <input type="checkbox"/> Partnership Firm; <input type="checkbox"/> Single Ownership
15	Name of Owner / Partner's of Firm	
16	GST No.	

**TECHNICAL CONDITION DETAIL**

Sr. No.	Elements	Response	Remarks
1	Technical : Supply of Foundation Bolts as per tender documents (if selected 'Accepted with deviation', please mention the deviation clearly)	Select from the drop down list	

**COMMERCIAL CONDITIONS & DETAILS**

Sr. No.	Elements	Response	Remarks (if any)
1	IGST supply (%)	Select from the drop down list	
2	SGST supply (%)	Select from the drop down list	
3	CGST supply (%)	Select from the drop down list	
4	Validity: <b>70</b> days from techno commercial bid opening.	Select from the drop down list	
5	Delivery period: Within <b>75</b> days from placement of PO / LOI. (Refer special term S4)	Select from the drop down list	
6	Delivery Destination (refer tender special term S4)	Delivery will be at NTPC Talcher Site, Odisha	Select from the drop down list
7	Unloading (refer tender special term S4)	Unloading at Talcher Site to be arranged by BHEL Site.	Select from the drop down list
8	Welding Qualification (refer tender special term S1)	WPS,PQR,WQ to be reviewed/Witnessed (PQR-As per AWS D1.1).by QC BHEL IVP Goindwal. Supplier need to intimate to BHEL before starting of welding.	Select from the drop down list
9	Self Declaration by Bidder : It is hereby declared that Bidder is engaged in the manufacturing of Fasteners / Fabrication Jobs (Refer special terms S2.1).	Select from the drop down list	

## PART-I (TECHNO-COMMERCIAL BID)

(To be filled by bidder & submit with offer as pdf file only)

**Tender Enquiry No. & Date**

**2324-038E Dt. 05.08.2023**

**Tender Description**

**Supply of Foundation Bolts**

Bidder must note following points:

1. This workbook is protected, except for cells where comments / confirmation is to be given by bidder.
2. Bidder is advised not to unprotect / tamper the sheet / alter the terms mentioned in the sheet.
3. Any alteration to terms mentioned by BHEL will be considered as tampering and bidder's offer shall be liable for rejection.
4. **Bidders are advised to only fill the unprotected cells (shaded cells) by dropdown or writing the comments as applicable as their confirmation. Bidders are advised to submit duly filled & signed 'PDF' file as techno-commercial (Part-I) bid'. Failure on the part of bidder in not returning this duly filled-up techno-commercial bid and / or submitting incomplete replies may lead to rejection of bidder's quotation.**
5. All the commercial terms and conditions shall be indicated by vendor in this format only and nowhere else in his quotation. However, in case the space for vendor's reply is not sufficient against a particular question, the vendor shall furnish same by way of separate annexure / sheet attached to this questionnaire, indicating cross-reference of respective clauses.

10	Audited balance sheet, as applicable with minimum average turnover of Rs. 50 Lakhs/year over 3 financial years viz. FY 2019-20, 2020-21 and 2021-22 (Refer special terms S2.2)	Select from the drop down list	
11	Confirmations of Special terms as per <b>Annexure-P</b> (Refer special term S3 (d))	Select from the drop down list	
12	Conflict of Interest among Bidders / Agents (Refer clause no. 7 of General Contract conditions (GCC))	Not having Conflict of Interest with other Bidders	
13	LD clause: Penalty for late delivery will be applicable @ 0.5% per week or part thereof subject to a maximum of 10.0 %. (Refer Clause 11 of General Contract Conditions (GCC)).	Select from the drop down list	
14	Payment term: (Refer clause no. 13 of General Contract conditions (GCC))	Select from the drop down list	
15	<b>Warranty Period:</b> Supplier shall give a warrantee for a period of 18 months from the date of receipt. In case of non-acceptance of this term bid will be rejected. (Refer clause no. 18 of GCC)	Select from the drop down list	
16	Risk purchase: If the supplier fails to deliver the goods within the delivery specified in the Purchase Order, BHEL will be entitled to terminate the contract and to Purchase elsewhere at the risk and cost of the seller either the whole of the goods or any part which the supplier has failed to deliver or despatch within the delivery period mentioned in the Purchase Order. (Refer Cl. 21 of GCC in Tender Terms & Conditions)	Select from the drop down list	
17	Please attach valid MSE certificate latest MSME Guidelines (Refer clause no. 25 of GCC)	Select from drop down list	
18	Make in India (MII) (Refer clause no. 26 of GCC)	Local Content Declaration	Select from drop down list
		Details of location at which local value addition will be made is as follows:	Select from drop down list
19	Firm Price: The quoted / finalised rates shall be firm till execution of the supplies.	Select from the drop down list	
20	I have thoroughly gone through the attached tender terms & conditions and understood the above techno-commercial requirements	Select from drop down list	
21	If there is any deviation in reference to any of the tender term, kindly mention it <b>HERE</b> only. <b>Deviation specified elsewhere, will not be considered.</b>	Select from drop down list	

### Item detail

Item Sl. no.	Material Code	Description	Qty in Numbers	Quoted / not quoted
1	940760040000	FM FDN BLT DIA 50-1700 LONG	344	Select from the drop down list
2	940760030000	FM FDN BLT DIA 32-1050 LONG	4	Select from the drop down list
3	940670010000	FM FDN BLT DIA 25-900 LONG	36	Select from the drop down list
4	940760020000	FM FDN BLT DIA 40-1350 LONG	144	Select from the drop down list

We further, confirm that we have quoted the rates in the tender considering Inter-alia the

1. Tender Document(s)
2. Additional Document(s) (if any)
3. BOQ Document (Price Bid Format-Part-II)
4. Corrigendum (if any)
5. Pre Bid Meeting Minutes (if any)

We hereby certify that we have fully read and thoroughly understood the tender requirements and accept all terms and conditions of the tender including all corrigendum/addendum issued (if any). Our offer is in confirmation to all the terms and conditions of the tender including all corrigendum/addendum (if any) and minutes of the pre-bid meeting (if any). In the event our offer is found acceptable and Order is placed /Contract is awarded to us, the complete tender document shall be considered for constitution of Order / Contract Agreement.

[Validate](#)[Print](#)[Help](#)**Item Wise BoQ**

Tender Inviting Authority: BHEL IVP Goindwal Sahib

Name of Work: Supply of Foundation Bolts

Contract No: 2324-038E dated 05.08.2023

Name of the Bidder/ Bidding Firm / Company :

**PRICE SCHEDULE**

(This BOQ template must not be modified/replaced by the bidder and the same should be uploaded after filling the relevant columns, else the bidder is liable to be rejected for this tender. Bidders are allowed to enter the Bidder Name and Values only )

NUMBER #	TEXT #	TEXT #	NUMBER #	TEXT #	NUMBER #	NUMBER #	TEXT #
Sl. No.	Item Description <i>For all the items Delivery Destination is NTPC Talcher site</i>	Item Code / Make	Quantity	Units	BASIC RATE In Figures To be entered by the Bidder in Rs. Per Number	TOTAL AMOUNT excluding taxes in Rs. P	TOTAL AMOUNT In Words
1	2	3	4	5	7	11	13
1	FM FDN BLT DIA 50-1700 LONG	940760040000	344	Number		0.00	INR Zero Only
2	FM FDN BLT DIA 32-1050 LONG	940760030000	4	Number		0.00	INR Zero Only
3	FM FDN BLT DIA 25-900 LONG	940670010000	36	Number		0.00	INR Zero Only
4	FM FDN BLT DIA 40-1350 LONG	940760020000	144	Number		0.00	INR Zero Only



## SPECIAL TERMS AND CONDITIONS

Tender Enquiry No. 2324-038E Dated 05.08.2023 **Due date 16.08.2023**

**Tender Description:** Supply of Foundation Bolts

### S1. SCOPE OF SUPPLY

Material shall be supplied as per the applicable Technical Delivery Condition (TDC) / Drawing as mentioned in the Table – 1. National & International material standards shall have to be arranged by bidders themselves.

**Table 1 : List of Items along with Quantity, Drawing Number and Raw Material**

Sl. No.	Material Code	Description	Quantity (Nos.)	Drawing No.	Raw Material
1	940760040000	FM FDN BLT DIA 50-1700 LONG	344	2-FM-011-00003 Rev 04	IS2062E250A
2	940760030000	FM FDN BLT DIA 32-1050 LONG	4	2-FM-011-00010 Rev 01	IS2062E250A
3	940670010000	FM FDN BLT DIA 25-900 LONG	36	2-FM-011-00053 Rev 00	IS2062Fe410A
4	940760020000	FM FDN BLT DIA 40-1350 LONG	144	2-FM-011-00002 Rev 01	IS2062E250A

**Delivery Destination for all the items : NTPC Talcher Site.**

Hex Nuts to be Supplied as per IS-1363 P3 and Washers to be supplied as per IS-2016. This is applicable for ALL items.

(Specifications of Hex Nuts and Washers mentioned in the above drawings, (if any) are not Applicable).

“1 number” of Quantity = 1 Complete Fabricated Foundation Bolt along with Hex Nut and Washer, as detailed in the above referred Drawings.

Applicable ‘QUALITY CONTROL PROCEDURE’ for all the items: QCP:002/05 Dt. 07.03.2018.

**Additional Technical Information:**

Radiography Testing	Not applicable
MPI/LPI	To be done as per QCP002_rev 05
Applicable Quality document for fabricating Foundation Bolts.	QCP002_rev 05
Type of weld, Type of electrode, Total length of weld	As per applicable drawing
Welding Qualification	WPS, PQR, WQ to be reviewed/Witnessed (PQR-As per AWS D1.1).by QC BHEL IVP Goindwal. Supplier need to intimate to BHEL before starting of welding.
Pre-Heating for Welding and Flame cutting	Preheating procedure need to be followed as per clause of 4.3.3 of QCP002_rev05, Preheating temperature is 150 °C for welding and flame cutting.
Post Weld Heat Treatment	Not applicable

**Make in India (MII): Minimum 50% and 20% Local Content required for qualifying as Class 1 and Class 2 Local Supplier respectively.**



## SPECIAL TERMS AND CONDITIONS

Tender Enquiry No. 2324-038E Dated 05.08.2023 **Due date 16.08.2023**

**Tender Description:** Supply of Foundation Bolts

The **broad scope of work** in respect of all the items includes:

Procurement of raw materials, bought out items and consumables like electrodes, rust preventive oil etc. is to be done as per material Specifications/ Drawings/ Technical Delivery conditions (TDC's)/Quality Plan (QP).

Materials and consumables are to be procured with relevant Test Certificate (TC) and these have to be submitted/ produced in original during inspection. Any test, both destructive and non-destructive, if required, will have to be carried out by the vendors at their own cost. All such reports in original will have to be submitted during inspection. Vendors also shall verify the materials & TC to comply with the QP.

Manufacturing and fabrication of components shall be according to the drawings/Quality Plan (QP).

All handling charges till completion of fabrication & despatch up to destination is in Vendor's Scope. All costs towards testing & inspection including BHEL/ BHEL nominated agency as per BHEL's QP/PO /Drawings is in scope of supplier. However, BHEL will bear the cost for TPI during inspections.

- The rates quoted shall be firm and fixed. No price variation is proposed and allowed.
- Rates shall be quoted on **INR per No. basis**, excluding Taxes.
- Un-loading of material at Talcher Site shall be arranged by BHEL site.

### **S2. PRE-QUALIFICATION CRITERIA (POC)**

1. Bidder should either be engaged in manufacturing of Fasteners or should be engaged in fabrication jobs. Offers from Traders/Dealers/Stockists/agents will summarily be rejected. Submission of Certificate of Registration or UDYAM Certificate or Declaration from bidder for proof as a manufacturer is required to fulfil this criterion.
2. Bidder should have minimum average turnover of Rs. 50 Lakhs/year over three financial years viz. FY 2019-20, 2020-21 and 2021-22. To certify the same, bidder need to submit balance sheets of above stated three years. Balance sheets should be audited, as applicable. If the balance sheets are not audited, bidder need to submit CA certificate for the turnover.

**Start-ups shall be exempted** from the above criteria without any relaxation in quality standards or technical parameters as per D.O. No. 5(4)/2016-BE-I dated 15.02.2017. For claiming Start-Up exemption, vendors have to submit DPIIT (Dept. of Promotion of Industry and Internal Trade)/DIPP (Department for Industrial Policy and Promotion) recognition certificates.)

BHEL may carry out evaluation of bidder's capability. BHEL reserves the right to accept/reject any offer based on evaluation of bidder's capability. For verification of data presented for pre-qualification bid, BHEL may decide to visit the bidder(s) works. Any fact found deviating from bids during evaluation shall make the bidder liable to be dis-qualified.



## SPECIAL TERMS AND CONDITIONS

Tender Enquiry No. 2324-038E Dated 05.08.2023 **Due date 16.08.2023**

**Tender Description:** Supply of Foundation Bolts

### S3. PART-I: TECHNO-COMMERCIAL BID

Techno - Commercial Bid should contain *all the documents/confirmations as per following details:*

- a) Acceptance of Techno-Commercial terms and conditions shall be attached along with bid document. This can be attached either by signing each page of terms and conditions or a confirmation statement.

*IF THE OFFER IS NOT ACCOMPANIED WITH ACCEPTANCE OF TERMS AND CONDITIONS, IT SHALL BE CONCLUDED THAT ALL THE TERMS AND CONDITIONS ARE ACCEPTABLE AND NO CLAIM WHATSOEVER SHALL BE ENTERTAINED LATER ON.*

*IF THERE IS ANY DEVIATION IN REFERENCE TO ANY OF THE TENDER TERM, KINDLY MENTION IN PART-I TECHNO-COMMERCIAL BID ONLY. DEVIATION SPECIFIED ELSEWHERE, WILL NOT BE CONSIDERED.*

- b) MSE vendors should submit **UDYAM Registration Certificate** for availing applicable benefits for MSE vendors as per tender terms. Validity of document shall be considered as on date of Part I opening as per the latest available notification from Government.
- c) Documents as per pre-qualification terms.
- d) Duly filled Annexure – P (Confirmations of Special terms)

### S4. DELIVERY SCHEDULE

Delivery shall be within 75 days from date of Purchase Order/ Letter of Intent.

### S5. DELIVERY DESTINATION and SCOPE OF UNLOADING

Delivery Destination is NTPC Talcher. The material is to be supplied to NTPC Talcher Site at following address:

NTPC Talcher  
Project Site Address:  
Construction Manager,  
BHEL Site Office,  
2X660 MW NTPC Talcher,  
Distt. Angul – 759107  
Odisha, India

Contact Person:  
Sh. Mahesh Kumar  
Deputy Engineer  
Material Management  
NTPC Talcher Site  
Mobile: 95742 44431

**Unloading** of Material at NTPC Talcher Site is in the Scope of BHEL Site Office.

### S6. REVERSE AUCTION

Reverse auction will be conducted in this tender enquiry.



## SPECIAL TERMS AND CONDITIONS

Tender Enquiry No. 2324-038E Dated 05.08.2023 **Due date 16.08.2023**

**Tender Description:** Supply of Foundation Bolts

### **S7. DIFFERENTIAL FREIGHT CLAUSE**

The rates finalized against each schedule shall include cost of transporting finished products from Vendor's Works to delivery location specified in the tender.

All the consignments are normally envisaged for dispatch from Vendor's Works to specified location in the tender. However, in exceptional cases (in case of Project hold/ any unforeseen conditions), BHEL may permit Vendor(s) on case to case basis for handing over the consignments to some new location. BHEL's decision shall be final in this regard. In such case, differential freight charges shall be deducted or paid based on applicable distance.

#### **Differential Rates will be calculated as below:**

If BHEL advises to despatch material at any other location, then BHEL will calculate freight portion from vendor works to Location specified in tender (say it comes out amount 'X') and from vendor works to New location specified by BHEL (say it comes out amount 'Y'). Then differential freight cost will be calculated by subtracting both freight cost (Y-X). If it comes out to be positive, then this differential cost shall be given extra to vendor. If it comes out to be negative, then this differential amount shall be deducted from vendor. Kindly note that this extra payment to vendor/deduction from vendor shall be amended suitable in Purchase order before despatch.

For Calculation of Transportation freight, BHEL has mentioned Rate/KM/MT in INR from anywhere to anywhere in India. For calculating total cost, this needs to be multiplied by distance in KM & weight in MT.

#### **Rate/KM/MT from anywhere to anywhere is mentioned below:**

<b>Relevant category</b>	<b>Freight Rate per MT per KM</b>	<b>Remarks</b>
TAAA2	4.18	Anywhere to anywhere

Distance shall be taken in KM as shortest distance from Google map.

**Example:** Suppose one vendor is located in Ludhiana (Punjab). Distance from Ludhiana to BHEL Goindwal is approx. 150 KM & distance from Ludhiana to Talcher site is approx.1900 KM. The specified destination in tender is Talcher and the new location specified for delivery of material is Goindwal. Suppose weight of consignment is 60 MT  
Then freight from Ludhiana to Goindwal (Y) comes out to be Rs.  $4.18 \times 150 \times 60 = 37,620.00$ . The freight from Ludhiana to Talcher (X) comes out to be Rs.  $4.18 \times 1900 \times 60 = 4,76,520.00$ . Now differential cost (Y-X) comes out to be Rs.  $(- )4,38,900.00$ . Hence this differential amount will be deducted from vendor.



## SPECIAL TERMS AND CONDITIONS

Tender Enquiry No. 2324-038E Dated 05.08.2023 **Due date 16.08.2023**

**Tender Description:** Supply of Foundation Bolts

### **S8. PACKING OF MATERIAL**

The project name, PGMA, DU Number, quantity, weight, Vendor code shall be legibly stenciled for identification and dispatch as may be advised. Vendor code shall be punched using letter punch and bordered suitably for identification. Machined surfaces shall be protected with rust preventive oil. Threaded portions shall be protected with rust preventive oil and covered by tar impregnated Gunny cloth.

Material is to be sent in crates and the maximum weight in a single crate should not be more than 2MT.

**Example of packing is as below:**



### **S9. INSPECTION**

Bidders will submit TPI (Third party inspection) / BHEL Inspection report to BHEL IVP after inspection. Then based on Inspection report, BHEL will give dispatch clearance and then only the material shall be supplied to the respective consignee address.

### **S10. QUANTITY VARIATION**

+/-10% Variation in the quantity is applicable in this tender enquiry.

**These Special terms & conditions and General Contract Conditions (GCC) collectively are the part of tender terms and conditions.**



## General Conditions of Contract (GCC) of MM Tenders

**BHARAT HEAVY ELECTRICALS LIMITED**

Industrial Valve Plant: 433, Industrial Complex,  
Goindwal Sahib, Dist. Tarn Taran,  
Punjab-143422 (INDIA)

### TABLE OF CONTENTS

1. Instruction to Bidder .....	2
2. Scope of Supply .....	2
3. Price Basis.....	3
4. Discrepancy in Words And Figures.....	3
5. Evaluation in Case of More Than One L-1 Bidder.....	3
6. Reverse Auction.....	4
7. Conflict of Interest among Bidders / Agents .....	4
8. Validity of Offers.....	5
9. Supplied Material Adjustment.....	5
10. Delivery Schedule.....	5
11. Liquidated Damaged (LD).....	5
12. Acceptance of Material Supplied.....	5
13. Payment Terms .....	6
14. Taxes & Duties .....	7
15. Liability Under Reverse Charge (RCM).....	7
16. Access to Manufacturing Premises.....	7
17. Inspection.....	7
18. Warrantee and Corresponding Repair / Replacement of Goods.....	8
19. LOI (Letter of Intent).....	9
20. Sub-Contract .....	9
21. Risk Purchase.....	9
22. Force Majeure .....	9
23. Non-Disclosure Agreement .....	10
24. Clarifications.....	10
25. Preferences for Micro and Small Enterprises (MSEs).....	10
26. Preference to Make in India.....	11
27. Restrictions Under Rule 144(XI) of The General Financial Rules (GFR), 2017 .....	11
28. Resolution of Disputes.....	13
29. Fraud Prevention Policy.....	14
30. Preventive Checks to Eliminate Suspected Cartel Formation .....	15
31. Suspension of Business Dealings with Suppliers / Contractors .....	15
32. General.....	16
Annexure-X.....	18
Appendix-I of Annexure-X.....	24
Appendix-II of Annexure-X .....	25
Appendix-III of Annexure-X .....	26





## General Conditions of Contract (GCC) of MM Tenders

**BHARAT HEAVY ELECTRICALS LIMITED**

Industrial Valve Plant: 433, Industrial Complex,  
Goindwal Sahib, Dist. Tarn Taran,  
Punjab-143422 (INDIA)

### 1. Instruction to Bidder

Quotations shall be submitted before due date and time. Late offers are liable to be rejected, so please ensure to submit bid well within due date and time. Techno-commercial part will be opened on due date.

**Based on evaluation of techno-commercial offers, Price bids of bidders who qualify from techno-commercial evaluation shall be opened. BHEL may decide to open the Price bid same day at 1700 hrs. If not opened on the same day, all qualifying bidders shall be notified for date of opening of Price bids by email/fax/post/courier/E-procurement system generated email.**

#### 1.1 Instruction to Bidder (In case of Non-E-Procurement / Paper/ Manual/ Hard Copy based tenders)

Sealed Tenders can be dropped in the tender box labeled as 'Tender box for MM contracts.' This tender box is located at the entrance of Admin block BHEL Goindwal. Quotations can also be submitted through e-mail at **tendermm\_ivp@bhel.in**. Offers received in time shall be considered only when offers are complete in all respects. In case of bulky tenders, please handover quotation to Sh. Rakesh Kumar/ AGM - Head-MM or Sh. Sumeet Bansal / Sr. Manager - MM [Contact: 01859 224 615 / 628]. Bid can be sent to following address:

**BHEL, Industrial Valve Plant,  
#433, Industrial Complex,  
Goindwal Sahib, Distt. Tarn Taran,  
Punjab-143422.**

#### 1.2 Instruction to bidder (In case of E-Procurement)

1. Interested bidders / suppliers shall submit their offer through e-procurement mode at <https://eprocurebhel.co.in/>.
2. **Offers in any other mode will not be accepted.**
3. Procedure for submission of tender is available in the "Bidder Manual Kit" at e-tender portal <https://eprocurebhel.co.in/>.
4. In case of any difficulty faced while registering on BHEL's e-Procurement portal developed by NIC, queries may be addressed to 0120-4001002, 0120-4001005 and 0120-6277787; email: [support-eproc@nic.in](mailto:support-eproc@nic.in). These details are also available on 'Contact Us' page of the portal.
5. Before uploading scanned documents if any, the bidders shall sign on all the statements, documents, certificates uploaded by him, owning responsibility for their correctness / authenticity.
6. **Disclaimer clause:** Neither the Organization (Bharat Heavy Electricals Ltd.) nor the service provider is responsible for any failure of submission of bids due to failure of internet or other connectivity problems or reasons thereof.

### 2. Scope of Supply

Material shall be supplied as per the applicable latest Technical Delivery Conditions (TDC)/ Material Standard requirements/BPS/Drawing and other requirement as given in the Tender Enquiry. National & International material Standards shall have to be arranged by vendors themselves. Latest applicable revisions of standards/procedures to be referred.





## General Conditions of Contract (GCC) of MM Tenders

### BHARAT HEAVY ELECTRICALS LIMITED

Industrial Valve Plant: 433, Industrial Complex,  
Goindwal Sahib, Dist. Tarn Taran,  
Punjab-143422 (INDIA)

All required tests as called in referred material standard/BHEL/TDC/drawing etc. shall be carried out by vendor at no extra cost. Material Test Certificates (MTC), inspection reports and Compliance/Guarantee Certificate are to be provided along with the supplies.

### 3. Price Basis

1. Order of enquiry item sl. no. shall be maintained in the quotation.
2. The rates quoted shall be firm and fixed. No price variation is proposed and allowed.
3. Rates quoted should be FOR BHEL Goindwal basis. The offers quoted on other than FOR Goindwal basis are liable to be rejected.

In case bidder has quoted Ex-works prices, then he/she will be given an opportunity to accept price basis as FOR Goindwal either by accepting delivery as FOR Goindwal in same quoted price or by providing loading factor on his/her quoted ex-works prices to make them FOR prices.

**Variation in GST or any other statutory levies during contractual delivery period shall be to BHEL's account.**

### 4. Discrepancy in Words And Figures

1. If, in the price structure quoted for the required goods/ services/ works, there is discrepancy between the unit price and the total price (which is obtained by multiplying the unit price by the quantity}, the unit price shall prevail and the total price corrected accordingly, unless in the opinion of the purchaser there is an obvious misplacement of the decimal point in the unit price, in which case the total price as quoted shall govern and the unit price corrected accordingly.
2. If there is an error in a total corresponding to the addition or subtraction of subtotals, the subtotals shall prevail and the total shall be corrected; and
3. If there is a discrepancy between words and figures, the amount in words shall prevail, unless the amount expressed in words is related to an arithmetic error, in which case the amount in figures shall prevail subject of (a) and (b) above.
4. If there is such discrepancy in an offer, the same shall be conveyed to the bidder with target date upto which the bidder has to send his acceptance on the above lines and if the bidder does not agree to the decision of the purchaser, the bid is liable to be ignored.
5. Bids should be free from correction, overwriting, using corrective fluid, etc. Any interlineation, cutting, erasure or overwriting shall be valid only if they are attested under full signature(s) of person(s) signing the bid else shall be liable for rejection.
6. All overwriting/cutting, etc will be numbered by bid opening officials and announced during bid opening.

### 5. Evaluation in Case of More Than One L-1 Bidder

In the course of evaluation, if more than one bidder happens to occupy L1 status, effective L1 will be decided by soliciting discounts from the respective L1 bidders.

In case more than one bidder happens to occupy the L1 status even after soliciting discounts, the L1 bidder shall be decided by a toss / draw of lots, in the presence of the respective L1 bidder(s) or their representative(s).

Ranking will be done accordingly. BHEL's decision in such situations shall be final and binding.

Signature Not Verified  
Signed By: RAKESH  
KUMAR  
Location: BHEL, Goindwal  
Signing Date: 17.07.2023





## General Conditions of Contract (GCC) of MM Tenders

### BHARAT HEAVY ELECTRICALS LIMITED

Industrial Valve Plant: 433, Industrial Complex,  
Goindwal Sahib, Dist. Tarn Taran,  
Punjab-143422 (INDIA)

#### 6. Reverse Auction

In case, it is declared in special terms & conditions of tender enquiry that RA is applicable for the NIT, then RA will be conducted as per following clause:

BHEL shall be resorting to Reverse Auction (RA) (Guidelines as available on <https://www.bhel.com/>) for this tender. RA shall be conducted among the techno-commercially qualified bidders as per RA guidelines.

Price bids of all techno-commercially qualified bidders shall be opened and same shall be considered for RA. In case any bidder(s) do(es) not participate in online Reverse Auction, their sealed envelope price bid along with applicable loading, if any, shall be considered for ranking.

#### 7. Conflict of Interest among Bidders / Agents

A bidder shall not have conflict of interest with other bidders. Such conflict of interest can lead to anti-competitive practices to the detriment of Procuring Entity's interests. ***The bidder found to have a conflict of interest shall be disqualified.*** A bidder may be considered to have a conflict of interest with one or more parties in this bidding process, if:

- a) they have controlling partner (s) in common; **or**
- b) they receive or have received any direct or indirect subsidy/ financial stake from any of them; **or**
- c) they have the same legal representative/agent for purposes of this bid; **or**
- d) they have relationship with each other, directly or through common third parties, that puts them in a position to have access to information about or influence on the bid of another Bidder; **or**
- e) Bidder participates in more than one bid in this bidding process. Participation by a Bidder in more than one Bid will result in the disqualification of all bids in which the parties are involved. However, this does not limit the inclusion of the components/ sub-assembly/ Assemblies from one bidding manufacturer in more than one bid. **or**
- f) In cases of agents quoting in offshore procurements, on behalf of their principal manufacturers, one agent cannot represent two manufacturers or quote on their behalf in a particular tender enquiry. One manufacturer can also authorise only one agent/dealer. There can be only one bid from the following:
  1. The principal manufacturer directly or through one Indian agent on his behalf; and
  2. Indian/foreign agent on behalf of only one principal.**or**
- g) a Bidder or any of its affiliates participated as a consultant in the preparation of the design or technical specifications of the contract that is the subject of the Bid; **or**
- h) In case of a holding company having more than one independently manufacturing units, or more than one unit having common business ownership/management, only one unit should quote. Similar restrictions would apply to closely related sister companies. Bidders must proactively declare such sister/ common business/ management units in same/ similar line of business.





## General Conditions of Contract (GCC) of MM Tenders

**BHARAT HEAVY ELECTRICALS LIMITED**

Industrial Valve Plant: 433, Industrial Complex,  
Goindwal Sahib, Dist. Tarn Taran,  
Punjab-143422 (INDIA)

### 8. Validity of Offers

The offers shall be kept open for acceptance 'for number of days mentioned in special terms and conditions' from the date of opening of the tender. In case of tender extension, the bid validity shall be considered from the date of tender opening.

### 9. Supplied Material Adjustment

Item/s pending in previous PO has to be billed in previous PO only. Otherwise, BHEL will be free to adjust the supplies in previous PO. Any implication of tax will be on supplier's account. For this it is desirable that vendor should reconcile the pending PO statement every month/frequently with BHEL. Vendor can also view these details at Portal (<https://trichy.bhel.com/mm/index.jsp>).

### 10. Delivery Schedule

Supplies shall be affected and completed as per schedule mentioned in special terms and conditions. Commencement of delivery period shall be reckoned from the date of PO / LOI or any other agreed milestone.

### 11. Liquidated Damaged (LD)

- Time is the essence of the contract.
- The ordered items shall be delivered as per the delivery period mentioned in the Purchase Order.
- In case the supplier supplies the ordered items beyond the delivery period specified, Liquidated Damages -LD - as detailed below shall be will be levied from the supplier without prejudice to any other relief /compensation available to BHEL, Punjab under any other condition of the contract/applicable legal provisions.
- Failure to dispatch the materials in the time as per the delivery mentioned in our Purchase Order (PO) would make the supplier liable to an un-conditional LD at the rate of 0.5% of the undelivered order value per week of the delay or part thereof subject to a maximum of 10% of the undelivered order value.
- Any deviation from the above LD clause, loading will be applied to the extent to which it is not agreed by the bidder (at offered value).
- Indigenous: In case of Ex-works delivery terms, the document date (Invoice/Challan date) in Goods Receipt (GR) document shall be reckoned for LD deduction. In case of FOR Delivery terms, the posting date in GR document shall be reckoned for LD deduction.
- Import: For CFR terms, BL date will be considered for LD calculation.

BHEL reserves the right to receive or not receive the material after the due date of PO. Applicable GST shall also be recovered from suppliers/contractors on LD amount. For this Debit note will be issued by BHEL indicating the respective supply invoice number.

### 12. Acceptance of Material Supplied

- The supply shall strictly as per the specifications in the tender /purchase order.
- Delivery of the ordered items as per the delivery terms in the Purchase Order does not automatically constitute acceptance of the delivered items.
- Acceptance of the materials supplied will be based on the inspection and certification documents by the supplier as stipulated in the Purchase order. However, BHEL reserves the right to test the





## General Conditions of Contract (GCC) of MM Tenders

### BHARAT HEAVY ELECTRICALS LIMITED

Industrial Valve Plant: 433, Industrial Complex,  
Goindwal Sahib, Dist. Tarn Taran,  
Punjab-143422 (INDIA)

material supplied, if required, at BHEL Lab or any other approved/accredited lab and the result will be binding on the supplier.

4. The acceptance or otherwise of the delivered items will be separately communicated to the supplier by BHEL through B2B portal within 15 days from the delivery of items or delivery of the required test certificates /other documents whichever is later.
5. In case of rejection of the delivered items, either part or full, the vendor shall replace the rejected items as per the specification in the Purchase order/tender at their cost within 30 days of communication of rejection to the supplier. The supplier shall be given maximum two opportunities to replace the rejected items.
6. After the clearance of the 1st lot, in case of rejection of the delivered items, either part or full, if the supplier fails to replace the rejected items within 30 days of communication of the rejection, the same shall be treated as failure to execute the contract and actions as per the Guidelines for Suspension of Business Dealings with Suppliers /Contractors available in the webpage: <https://www.bhel.com> would be taken against such supplier.

### 13. Payment Terms

1. Payments shall be made to the Seller within the mentioned days (as per below table) from the date of receipt and acceptance of material.

Type of Bidder	Payment Terms (Number of days)
Micro & Small Enterprises (MSEs)	45 days
Medium Enterprises	60 days
Non MSME	90 days

To be considered as Micro, Small or Medium enterprise, bidder must be manufacturer of offer product and relevant valid certificate as per latest MSME guidelines is to be submitted along with bid.

**MSME bidders can avail benefits of payment through TReDS (Trade Receivable e Discounting System).**

In case of any deviation from standard payment term mentioned above, BHEL shall load on the item price at "Base rate of SBI (as applicable on the date of bid opening; Techno-commercial bid opening) + 6% for the period of relaxation sought by bidders.

2. Documents to be submitted (if applicable)
  - i) Tax invoice (Invoice shall be GST compliant and should contains all the required information such as GST No, HSN code etc.)
  - ii) Transporter copy along with material/consignment.
  - iii) Material Test Certificates (MTC) and
  - iv) Compliance Certificate.
3. GST registration number is to be submitted by qualified vendor as per GST law.
4. It is mandatory to mention proper material codes in the invoices and separate invoices to be raised for different POs.
5. **BHEL releases payment through EFT mode ONLY. Necessary details may please be submitted by filling required format before release of payment.**





## General Conditions of Contract (GCC) of MM Tenders

### BHARAT HEAVY ELECTRICALS LIMITED

Industrial Valve Plant: 433, Industrial Complex,  
Goindwal Sahib, Dist. Tarn Taran,  
Punjab-143422 (INDIA)

#### 14. Taxes & Duties

Payment of GST portion will be released to vendor only upon completion of statutory requirement and further subject to following:

- Vendor declaring such invoice in his GSTR-1 and
- Receipt of goods and Tax invoice by BHEL and
- Confirmation of payment of GST thereon by vendor on GSTN portal.
- Above is subject to receipt of goods/service and tax invoice thereof along with vendor declaring invoice in his return and paying GST within timeline prescribed for availing ITC by BHEL.

Following may please be noted for availing Input Tax Credit (ITC) by BHEL:

- Since ITC can be availed only when BHEL is in possession of GST Tax invoice and after receipt of goods. Thus, vendor to ensure timely dispatch of goods and Tax invoice. It may be noted that in case of any delay in receipt of Tax Invoice and/or receipt of goods, the ITC availment by BHEL will get delayed thus entailing additional cash outflow & may even get denied if ITC availment timelines are breached.
- Further ITC can be availed only when vendor has declared such invoice in his outward supply Return GSTR-1 and after GST thereon has been paid by him at the time of filing of monthly Return.
- If GST credit is delayed/denied to BHEL due to non/delayed receipt of goods and/or tax invoice or expiry of timeline prescribed in GST law for availing such ITC, or any other reasons not attributable to BHEL, GST amount shall be recoverable from vendor along with interest levied/leviable on BHEL.
- Further, in case vendor delays declaring such invoice in his return and GST credit availed by BHEL is denied or reversed subsequently as per GST law, GST amount paid by BHEL towards such ITC reversal as per GST law shall be recoverable from vendor/contractor along with interest levied/leviable on BHEL.

#### 15. Liability Under Reverse Charge (RCM)

Any GST liability arising on BHEL under Reverse Charge (RCM) before actual receipt of goods and/ or Invoice thereof would be subject to recovery of Interest leviable for the period between the date of such liability and actual date of eligibility of ITC based on receipt of goods, receipt of Invoices and other conditions specified in GST Law as applicable.

#### 16. Access to Manufacturing Premises

While Purchase Orders placed on the vendor are under execution, authorized representatives of BHEL shall be allowed free access to the manufacturing facilities for the purpose of inspection or monitoring the progress of purchase orders. This access will also be extended to representatives of BHEL's customers accompanying the authorized representative/s of BHEL (which shall be intimated in advance), if our contractual requirements with our customers call for the same.

#### 17. Inspection

- The seller shall give adequate notice, of 1 week or as mutually agreed period, in writing to the Purchaser about the date and place at which the goods will be ready for inspection/ testing, as provided for in the contract.





## General Conditions of Contract (GCC) of MM Tenders

### BHARAT HEAVY ELECTRICALS LIMITED

Industrial Valve Plant: 433, Industrial Complex,  
Goindwal Sahib, Dist. Tarn Taran,  
Punjab-143422 (INDIA)

2. Purchaser or his authorized representative shall be entitled to carry out inspection of material and workmanship/Surveillance Audit at Seller's premises or at his sub-contractor's premises at all reasonable times during execution of contract; Such inspection, examination and testing, if made, shall not absolve the Seller from his obligations under the contract. No additional charges shall be claimed for such inspections. Moreover, all required infrastructure (testing, tools etc) have to be arranged by supplier.
3. Any inspection carried out before supply by vendor/incoming stage at BHEL notwithstanding, if any defect/non-conformity is noted during processing, the same shall be attended/replaced by vendor at no extra cost.
4. BHEL representative from unit or CQ is authorized to carry out audits along with TPIA at vendor's works before clearing the items for dispatch.
5. Necessary tooling including thread gauges etc. have to be arranged by vendor. Only in exceptional cases, based on BHEL discretions item/nature, BHEL may consider request to provide gauges if available with BHEL. But in no case this shall be linked with delivery of material.
6. In case of following points, visit charges to be paid to Third Party Inspection Agency (TPIA) shall be imposed as penalty on Supplier:
  - a) Nothing/NIL material is offered during Inspection (whilst physical visit of Inspection Engineer at Supplier's work) with respect to "Offered Quantity" mentioned in raised Inspection Call.
  - b) Lapses on the account of supplier has led to rejection of offered material (as per approved QAP/ Technical Specifications/ Other pertinent requirement), while carrying out Inspection.
  - c) Less Quantity/ Short Quantity is offered during Inspection (whilst physical visit of Inspection Engineer at Supplier's work) with respect to "Offered Quantity" mentioned in raised Inspection Call for any of the line(s) item, leading to re-visit of Inspection Engineer.

### 18. Warrantee and Corresponding Repair / Replacement of Goods

Goods shall comply with the specifications for material, workmanship and performance. Unless otherwise specified, vendor shall give a warrantee against design & manufacturing defects for a period of 18 months from the date of receipt. In case of non-acceptance of this term, bid shall be liable for rejection.

If the delivery is found non-compliant during the warranty period, leading to rejection, the Seller shall arrange free replacement / repair of goods, within one month from the date of intimation. Corresponding quantity shall be treated as unsupplied against respective purchase order till replacement is received at BHEL. In the event of the Seller's failure to comply, Purchaser may take action as appropriate, including repair / replenish rejected goods, at the risk & cost of the Seller.

All incidental charges like freight, insurance and customs duty in respect of return of defective items are to vendor's account only. BHEL will inform related invoice, quantity etc. to supplier. Supplier has to give advance intimation / plan (Transporter, Vehicle details) for the lifting of material. Further supplier has to provide requisite documents (such as Credit Note, e-Way Bill etc.) to lift the rejected material. Material should be lifted within one month from date of intimation. After one-month, BHEL will not be responsible for rejected material and BHEL shall have the right to dispose off such rejected material.





## General Conditions of Contract (GCC) of MM Tenders

**BHARAT HEAVY ELECTRICALS LIMITED**

Industrial Valve Plant: 433, Industrial Complex,  
Goindwal Sahib, Dist. Tarn Taran,  
Punjab-143422 (INDIA)

The defective parts and components shall be collected by your Indian agent or / authorized person, only after completing the replacement / repairs. If the supplier fails to replace / rectify the defective/ damaged items on free of cost within one month of reporting from our end, the same shall be treated as failure to execute the contract and actions as per the Guidelines for Suspension of Business Dealings with Suppliers /Contractors available in the webpage: <https://www.bhel.com> would be taken against such supplier without prejudice to the other remedies available to BHEL under the contract and law in this regard.

### 19. LOI (Letter of Intent)

BHEL may issue LOI prior to the PO for any reason whatsoever. The LOI in such cases is to be treated as PO for all practical purposes and all the Terms & Conditions of the tender shall be applicable from the date of issue of LOI.

### 20. Sub-Contract

The purchase order or any part thereof shall not be sub-contracted, assigned or otherwise transferred without previously obtaining the BHEL's consent in writing.

### 21. Risk Purchase

1. In the event of any successful Tenderer's failure to fulfil any of the tender / Contract obligations including supply of whole or any part of the ordered items as per Contract / Agreement, BHEL has the right to terminate the contract and purchase from elsewhere, at the risk and cost of the defaulted supplier, either the whole of the goods or any part which the supplier has failed to deliver or dispatch within the time stipulated in the contract or if the same were not available, the best and nearest available substitute thereof. The supplier shall be liable for the additional expenditure/difference in Cost, if any, including consequential losses which BHEL may sustain by reason of risk purchase in addition to the applicable LD as per the Purchase order/contract.
2. The decision of BHEL with regard to the additional expenditure / difference in cost and consequential losses incurred by BHEL shall be final and binding on the supplier.
3. The amount recoverable under risk purchase shall be recovered from the defaulted supplier in all or any of the following manners:
  - from dues available in the form of Bills payable to defaulted supplier, SD, BGs against the same contract.
  - from the dues payable to defaulted supplier against other contracts in the same Region/Unit /any other region/unit. In-case recoveries are not possible with any of the above available options, Legal action shall be initiated for recovery against defaulted supplier.

### 22. Force Majeure

1. Notwithstanding the provisions contained in other clauses, the supplier shall not be liable for imposition of any such sanction so long the delay and/or failure of the supplier in fulfilling its obligations under the contract is the result of an event of Force Majeure. For purposes of this clause, Force Majeure means an event beyond the control of the supplier and not involving the supplier's fault or negligence and which is not foreseeable and not brought about at the instance of the party claiming to be affected by such event and which has caused the non – performance or delay in performance. Such events may include, but are not restricted to, wars or revolutions, hostility, acts

Signature Not Verified

Signed By: RAKESH

KUMAR

Location: BHEL, Goindwal

Signing Date: 17.07.2023





## General Conditions of Contract (GCC) of MM Tenders

### BHARAT HEAVY ELECTRICALS LIMITED

Industrial Valve Plant: 433, Industrial Complex,  
Goindwal Sahib, Dist. Tarn Taran,  
Punjab-143422 (INDIA)

of public enemy, civil commotion, sabotage, fires, floods, explosions, epidemics, quarantine restrictions, strikes excluding by its employees, lockouts excluding by its management, freight embargoes and Acts of GOD.

2. If a Force Majeure situation arises, the supplier shall promptly notify the Purchaser/Consignee in writing of such conditions and the cause thereof within twenty-one days of occurrence of such event. Unless otherwise directed by the Purchaser/Consignee in writing, the supplier shall continue to perform its obligations under the contract as far as reasonably practical, and shall seek all reasonable alternative means for performance not prevented by the Force Majeure event.
3. If the performance in whole or in part or any obligation under this contract is prevented or delayed by any reason of Force Majeure for a period exceeding sixty days, either party may at its option terminate the contract without any financial repercussion on either side.
4. In case due to a Force Majeure event the Purchaser/Consignee is unable to fulfil its contractual commitment and responsibility, the Purchaser/Consignee will notify the supplier accordingly and subsequent actions taken on similar lines described in above sub-paragraphs.

### 23. Non-Disclosure Agreement

All Drawing and technical documents relating to the product or it's manufacture submitted by one party to the other, prior or subsequent to the formation of contract, shall remain property of the submitting party. Drawing, technical documents or other technical information received by one party, shall not without the consent of the other party, be used for any other purpose than that, for which they were provided. Such technical information shall not without the consent of the submitting party, otherwise be used or copied, reproduced, transmitted or communicated to a third party. Patterns supplied by BHEL will remain BHEL's property which shall be returned by the bidder on demand to BHEL. Bidder shall in no way share or use such intellectual property of BHEL to promote his own business with others. ***BHEL reserves the right to claim damages from the bidder, or take appropriate penal action as deemed fit against the bidder, for any infringement of the provisions contained herein.***

### 24. Clarifications

The correspondence exchanged against the tender from both tenderer and BHEL through email/e-procurement are considered as valid document legally though it is not signed. It is treated as valid confirmations made on behalf of the respective company and very much comes under the legal ambit of the business transaction and hence it is binding on both the parties to the business. Any transaction pertaining to the tender from both the parties of business done round the clock irrespective of the office or business hours of the companies, are valid legally and binding on both the parties. This applies to the extent only in such cases where deadline time for transaction is not specifically declared by either or both the parties to the business.

### 25. Preferences for Micro and Small Enterprises (MSEs)

Preferences as mentioned in “Public Procurement Policy for Micro and Small Enterprises (MSEs) Order, 2012” & “Public Procurement Policy for Micro and Small Enterprises (MSEs) Amendment Order, 2018”, or as per latest guidelines issued by government shall be given to Micro and Small enterprises.





## General Conditions of Contract (GCC) of MM Tenders

### BHARAT HEAVY ELECTRICALS LIMITED

Industrial Valve Plant: 433, Industrial Complex,  
Goindwal Sahib, Dist. Tarn Taran,  
Punjab-143422 (INDIA)

Main points which are mentioned in the above orders are as follows:

- 25% Procurement of the tender value shall be made from MSE (Micro, Small Enterprises) firms.
- 25% of the 25% quantity (i.e. 6.25% of the tender quantity) offered to the MSE's shall be reserved for MSE's owned by SC/STs. Failure to participate by any MSE owned by SC/ST's; this 6.25% quantity shall be procured from other MSEs.
- 3% from within the 25% quantity offered to the MSE's shall be reserved for women owned MSE's. Failure to participate by any MSE owned by women; this 3% quantity shall be procured from other MSEs.
- EMD shall be exempted for MSE's. All these benefits are subject to production of all statutory documents
- In tender, participating Micro and Small Enterprises quoting price within price band of L1+15 per cent shall also be allowed to supply a portion of requirement by bringing down their price to L1 price in a situation where L1 price is from someone other than a Micro and Small Enterprise and such Micro and Small Enterprise shall be allowed to supply up to 25 per cent of total tendered value. In case of more than one such Micro and Small Enterprise, the supply shall be shared proportionately (to tendered quantity).

MSE suppliers can avail the intended benefits only if they submit **Udyam Registration Certificate** along with the offer. No other document shall be considered for availing MSE benefits. Non-submission of such document will lead to consideration of their bid at par with other bidders. No benefit shall be applicable for this enquiry if any deficiency in the above required documents is not cleared before price bid opening. If the tender is to be submitted through e-procurement portal, then the above required document is to be uploaded on the portal.

*Note: It may however be noted that MSE guidelines as on date (Date of Technical Bid Opening Part-1) shall prevail.*

## 26. Preference to Make in India

This procurement shall be governed by notification no. P-45021/2/2017-PP (BE-II) dated 16.09.2020 of Government of India issued by DPIIT and subsequent circulars issued afterwards. Accordingly, the minimum local content, the margin of purchase preference and the procedure for purchase preference to make in India shall be adhered.

## 27. Restrictions Under Rule 144(XI) of The General Financial Rules (GFR), 2017

Restrictions on procurement from a bidder of a country which shares a land border with India

- a) Any bidder from a country which shares a land border with India will be eligible to bid in this tender, whether of goods or services (including consultancy services and non-consultancy services), only if the bidder is registered with the Competent Authority.
- b) Further, any bidder (including an Indian bidder) who has a Specified Transfer of Technology (ToT) arrangement with an entity from a country which shares a land border with India will be eligible to bid in any procurement whether of goods or services (including consultancy services and non-consultancy services) only if the bidder is registered with the Competent Authority. *This clause shall be applicable only in the tenders which attract restrictions due to specified ToT.*

Signature Not Verified  
Signed By: RAKESH  
KUMAR  
Location: BHEL, Goindwal  
Signing Date: 17.07.2023





## General Conditions of Contract (GCC) of MM Tenders

### BHARAT HEAVY ELECTRICALS LIMITED

Industrial Valve Plant: 433, Industrial Complex,  
Goindwal Sahib, Dist. Tarn Taran,  
Punjab-143422 (INDIA)

- II. "Bidder" (Seller / Service Provider) means any person or firm or company, including any member of a consortium or joint venture (that is an association of several persons, or firms or companies), every artificial juridical person not falling in any of the descriptions of bidders stated hereinbefore, including any agency branch or office controlled by such person, participating in a procurement process.
- III. "Bidder (or entity) from a country which shares a land border with India" for the purpose of the Order means:
- An entity incorporated, established, or registered in such a country; or
  - A subsidiary of an entity incorporated, established, or registered in such a country; or
  - An entity substantially controlled through entities incorporated, established, or registered in such a country; or
  - An entity whose beneficial owner is situated in such a country; or
  - An Indian (or other) agent of such an entity; or
  - A natural person who is a citizen of such a country; or
  - A consortium or joint venture where any member of the consortium or joint venture falls under any of the above
- IV. The beneficial owner for the purpose of (iv) above will be as under
- In case of a company or Limited Liability Partnership, the beneficial owner is the natural person(s), who, whether acting alone or together, or through one or more juridical person, has a controlling ownership interest or who exercises control through other means.  
Explanation—
    - "Controlling ownership interest" means ownership of or entitlement to more than twenty-five per cent. of shares or capital or profits of the company;
    - "Control" shall include the right to appoint majority of the directors or to control the management or policy decisions including by virtue of their shareholding or management rights or shareholders agreements or voting agreements;
  - In case of a partnership firm, the beneficial owner is the natural person(s) who, whether acting alone or together, or through one or more juridical person, has ownership of entitlement to more than fifteen percent of capital or profits of the partnership;
  - In case of an unincorporated association or body of individuals, the beneficial owner is the natural person(s), who, whether acting alone or together, or through one or more juridical person, has ownership of or entitlement to more than fifteen percent of the property or capital or profits of such association or body of individuals;
  - Where no natural person is identified under (1) or (2) or (3) above, the beneficial owner is the relevant natural person who holds the position of senior managing official;
  - In case of a trust, the identification of beneficial owner(s) shall include identification of the author of the trust, the trustee, the beneficiaries with fifteen percent or more interest in the trust and any other natural person exercising ultimate effective control over the trust through a chain of control or ownership.
- V. An Agent is a person employed to do any act for another, or to represent another in dealings with third person.
- VI. The registration shall be valid at the time of submission of bid and at the time of acceptance of bid.
- VII. If the bidder was validly registered at the time of acceptance / placement of order, registration shall not be a relevant consideration during contract execution.

Signature Not Verified

Signed By: RAKESH

KUMAR

Location: BHEL, Goindwal

Signing Date: 17.07.2023





## General Conditions of Contract (GCC) of MM Tenders

**BHARAT HEAVY ELECTRICALS LIMITED**

Industrial Valve Plant: 433, Industrial Complex,  
Goindwal Sahib, Dist. Tarn Taran,  
Punjab-143422 (INDIA)

VIII. "Transfer of Technology" means dissemination and transfer of all forms of commercially usable knowledge such as transfer of know-how, skills, technical expertise, designs, processes and procedures, trade secrets, which enables the acquirer of such technology to perform activities using the transferred technology independently.

Any false declaration and non-compliance of the above would be a ground for debarment and further legal action in accordance with law.

### **Bidder has to submit a certificate certifying following along with offer:**

"I have read the clause regarding restrictions on procurement from a bidder of a country which shares a land border with India; I certify that this bidder is not from such a country or, if from such a country, has been registered with the Competent Authority. I hereby certify that this bidder fulfils all requirements in this regard and is eligible to be considered. [Where applicable, evidence of valid registration by the Competent Authority shall be Attached]."

### **28. Resolution of Disputes**

The Parties agree that if at any time (whether before, during or after the arbitral or judicial proceedings), any Disputes (which term shall mean and include any dispute, difference, question or disagreement arising in connection with construction, meaning, operation, effect, interpretation or breach of the contract/tender which the Parties are unable to settle mutually), arise inter-se the Parties, the same may, be referred by either party to Conciliation to be conducted through Independent Experts Committee to be appointed by competent authority of BHEL from the BHEL Panel of Conciliators.

Notes:

1. No serving or a retired employee of BHEL/Administrative Ministry of BHEL shall be included in the BHEL Panel of Conciliators.
2. Any other person(s) can be appointed as Conciliator(s) who is/are mutually agreeable to both the parties from outside the BHEL Panel of Conciliators.

The proceedings of Conciliation shall broadly be governed by Part-III of the Arbitration and Conciliation Act 1996 or any statutory modification thereof and as provided in Annexure-X to this GCC.

The Annexure-X together with its appendices will be treated as if the same is part and parcel hereof and shall be as effectual as if set out herein in this GCC.

Except as provided elsewhere in this Contract, in case amicable settlement is not reached between the parties, in respect of any dispute or difference; arising out of the formation, breach, termination, validity or execution of the Contract; or, the respective rights and liabilities of the Parties; or, in relation to interpretation of any provision of the Contract; or, in any manner touching upon the Contract, then, either Party may, by a notice in writing to other Party, refer such dispute or difference to sole arbitration of an arbitrator appointed as per the Arbitration and Conciliation Act, 1996 (India) or statutory modification or re-enactment thereof and the rules made thereunder and for the time being in force.

Signature Not Verified

Signed By: RAKESH

KUMAR

Location: BHEL, Goindwal

Signing Date: 17.07.2023





## General Conditions of Contract (GCC) of MM Tenders

**BHARAT HEAVY ELECTRICALS LIMITED**

Industrial Valve Plant: 433, Industrial Complex,  
Goindwal Sahib, Dist. Tarn Taran,  
Punjab-143422 (INDIA)

The Arbitrator shall pass a reasoned award and the award of the Arbitrator shall be final and binding upon the parties.

This contract shall be governed, construed and interpreted in accordance with the laws of India.

Subject as aforesaid, the provisions of Arbitration & Conciliation Act 1996 (India) or statutory modification or re-enactment thereof and the rules made thereunder and for the time being in force shall apply to the arbitration proceeding under this clause.

The seat of arbitration shall be Tarn Taran, Punjab, India.

The cost of arbitration shall be borne as per the award of the Arbitrator.

Subject to arbitration in terms of clause above, the Courts at Tarn Taran, Punjab, India shall have exclusive jurisdiction over any matter arising out of or in connection with this Contract.

Notwithstanding the existence or any dispute or difference and/or reference for the arbitration, the vendor/contractor shall proceed with and continue without hindrance the performance of its obligation under this Contract with due diligence and expedition in a professional manner except where the Contract has been terminated by either Party in terms of this Contract.

**In Case of Contract with Public Sector Enterprise (PSE) or a Government Department, the following shall be applicable:**

In the event of any dispute or difference relating to the interpretation and application of the provisions of commercial contract(s) between Central Public Sector Enterprises (CPSEs)/Port Trusts inter se and also between CPSEs and Government Departments/Organizations (Excluding disputes concerning Railways, Income Tax, Customs & Excise Departments, such dispute or difference shall be taken up by either party for its resolution through AMRCD as mentioned in DPE OM No.05/003/2019-FTS-10937 dated 14<sup>th</sup> December, 2022 and the decision of AMRCD on the said dispute will be binding on both the parties.”

Set off : BHEL shall have the right to recover any money which in the sole opinion of BHEL is due from the supplier from any money due to the supplier under this Contract or any other contract or from the Security Deposit/BG furnished by the supplier under this Contract or any other contract.

### **29. Fraud Prevention Policy**

The Bidder along with its associate / collaborators / sub-contractors / sub-vendors / consultants / service providers shall strictly adhere to BHEL Fraud Prevention Policy displayed on BHEL website <https://www.bhel.com/> and shall immediately bring to the notice of BHEL management about any fraud or suspected fraud as soon as it comes to their notice.





## General Conditions of Contract (GCC) of MM Tenders

**BHARAT HEAVY ELECTRICALS LIMITED**

Industrial Valve Plant: 433, Industrial Complex,  
Goindwal Sahib, Dist. Tarn Taran,  
Punjab-143422 (INDIA)

### 30. Preventive Checks to Eliminate Suspected Cartel Formation

The Bidder declares that they will not enter into any illegal or undisclosed agreement or understanding, whether formal or informal with other Bidder(s). This applies in particular to prices, specifications, certifications, subsidiary contracts, submission or non-submission of bids or any other actions to restrict competitiveness or to introduce cartelization in the bidding process.

In case, the Bidder is found having indulged in above activities, suitable action shall be taken by BHEL as per extant policies/ guidelines.

### 31. Suspension of Business Dealings with Suppliers / Contractors

The offers of the bidders who are under suspension as also the offers of the bidders, who engage the services of the firms debarred across BHEL, shall be rejected. The list of firms debarred across BHEL is available on BHEL web site <https://www.bhel.com/>.

#### INTEGRITY COMMITMENT, PERFORMANCE OF THE CONTRACT AND PUNITIVE ACTION THEREOF:

##### 31.1. Commitment by BHEL:

BHEL commits to take all measures necessary to prevent corruption in connection with the tender process and execution of the contract. BHEL will during the tender process treat all Bidder(s) in a transparent and fair manner, and with equity.

##### 31.2. Commitment by Bidder/ Supplier/ Contractor:

31.2.1. The bidder/ supplier/ contractor commits to take all measures to prevent corruption and will not directly or indirectly influence any decision or benefit which he is not legally entitled to nor will act or omit in any manner which tantamount to an offence punishable under any provision of the Indian Penal Code, 1860 or any other law in force in India.

31.2.2. The bidder/ supplier/ contractor will, when presenting his bid, disclose any and all payments he has made, and is committed to or intends to make to agents, brokers or any other intermediaries in connection with the award of the contract and shall adhere to relevant guidelines issued from time to time by Govt. of India/ BHEL.

31.2.3. The bidder/ supplier/ contractor will perform/ execute the contract as per the contract terms & conditions and will not default without any reasonable cause, which causes loss of business/ money/ reputation, to BHEL.

If any bidder/ supplier/ contractor during pre-tendering/ tendering/ post tendering/ award/ execution/ post-execution stage indulges in mal-practices, cheating, bribery, fraud or and other misconduct or formation of cartel so as to influence the bidding process or influence the price or acts or omits in any manner which tantamount to an offence punishable under any provision of the Indian Penal Code, 1860 or any other law in force in India, then, action may be taken against such bidder/ supplier/ contractor as





## General Conditions of Contract (GCC) of MM Tenders

### BHARAT HEAVY ELECTRICALS LIMITED

Industrial Valve Plant: 433, Industrial Complex,  
Goindwal Sahib, Dist. Tarn Taran,  
Punjab-143422 (INDIA)

per extant guidelines of the company available on <https://www.bhel.com/> and/or under applicable legal provisions

### 32. General

1. BHEL will not be bound by any power of attorney granted by the vendors or by changes in the composition of the firm made subsequent to the execution of the contract. They may, however, recognize such power of attorney and changes after obtaining proper legal advice, the cost of which will be chargeable to the vendor concerned.
2. BHEL reserves the right to extend the due date of opening, which shall be informed. Validity of offer shall be deemed to be revised accordingly.
3. BHEL reserves the right to accept or reject any part or whole of the tender of a bidder by assigning a valid reason thereof. BHEL reserves the right to cancel the tender without assigning any reason thereof and without any obligation before any commitment.
4. Acceptance of all terms and conditions, in the form of signed copy of T&C or confirmation separately written, shall be submitted along with quotation. If nothing is mentioned, it shall be concluded that these terms and conditions are acceptable.
5. BHEL may increase/decrease item/s based on BHEL requirement before price bid opening. Suitable price implication may be asked from suppliers.
6. BHEL may drop item/items from tender at any stage of tender before placing PO. BHEL may also delete PO with consent with supplier within delivery date of PO.
7. After releasing PO, it is assumed that supplier has accepted PO if we do not receive acknowledgement from supplier within 5 days of date of PO.
8. In case of unscheduled holiday on opening day of tender, the next working day will be treated as scheduled prescribed day of opening of tender.
9. On the due date of tender opening, only technical bids will be opened. The opened technical bids will be evaluated by us and clarifications required, if any, will be called for from the bidders on technical and commercial points. If no reply is received from the vendor for the clarification raised by BHEL with in the final cut-off date, those vendors offer will be processed with the documents available / submitted against this tender. Offers not meeting the required specification and technical condition will be summarily rejected. The price bids of technically suitable bidders will be opened on a later date with prior intimation to techno-commercially suitable bidders.
10. Ranking L-1, L-2 etc. shall be done for individual item for the techno-commercially acceptable offers on landed cost to BHEL, IVP Goindwal basis and BHEL reserves the right to place order for individual items with different vendors.
11. BHEL reserves the right to negotiate with L1 vendor or re-float the tender for items where, L1 price is not the lowest acceptable price; BHEL reserves the right to increase or decrease the tender quantity.
12. If supplier is mentioning delivery destination within state/ outside state depending upon his location of factory, Free on Road etc. these are assumed as on FOR Goindwal. If supplier is wishing to give delivery on Ex works basis, then he has to clearly mention about it.
13. The bidder has to keep track of any changes by viewing the addendum(s) / Corrigendum(s) issued by the Purchaser on time-to- time basis in the E-Procurement platform. The Company calling for tenders shall not be responsible for any claims/problems arising out of this.

Signature Not Verified

Signed By: RAKESH

KUMAR

Location: BHEL, Goindwal

Signing Date: 17.07.2023





## General Conditions of Contract (GCC) of MM Tenders

**BHARAT HEAVY ELECTRICALS LIMITED**

Industrial Valve Plant: 433, Industrial Complex,  
Goindwal Sahib, Dist. Tarn Taran,  
Punjab-143422 (INDIA)

14. Unregistered suppliers, who are techno-commercially qualified against the open tender, are requested to register with BHEL as permanent supplier by submitting the Supplier Registration Form (SRF) in online supplier registration portal (<https://supplier.bhel.in/>).
15. The General Conditions of Contract and the Special Conditions in each enquiry and the resulting purchase order constitute the entire contract between the parties. In case of any discrepancy between the provisions of General Conditions of Contract and Special Conditions of the Tender, the provisions in Special Conditions of the Tender shall prevail and interpretation of BHEL of such condition/clause will be final and binding on both the parties ..





## General Conditions of Contract (GCC) of MM Tenders

**BHARAT HEAVY ELECTRICALS LIMITED**

Industrial Valve Plant: 433, Industrial Complex,  
Goindwal Sahib, Dist. Tarn Taran,  
Punjab-143422 (INDIA)

### Annexure-X

#### **BRIEF PROCEDURE FOR CONDUCT OF CONCILIATION PROCEEDINGS**

1. The proceedings of Conciliation shall broadly be governed by Part-III of the Arbitration and Conciliation Act 1996 or any statutory modification thereof and as provided herein:
2. The party desirous of resorting to Conciliation shall send an invitation/notice in writing to the other party to conciliate specifying all points of Disputes with details of the amount claimed. The party concerned shall not raise any new issue thereafter. Parties shall also not claim any interest on claims/counter-claims from the date of notice invoking Conciliation till the conclusion of the Conciliation proceedings.
3. The party receiving the invitation/notice for Conciliation shall within 30 days of receipt of the notice of Conciliation intimate its consent for Conciliation along with its counter-claims, if any.
4. The Conciliation in a matter involving claim or counter-claim (whichever is higher) up to Rs 5 crores shall be carried out by sole Conciliator nominated by BHEL while in a matter involving claim or counter-claim (whichever is higher) of more than Rs 5 crores Conciliation shall be carried out by 3 Conciliators nominated by BHEL.
5. The Parties shall be represented by only their duly authorized in-house executives/officers and neither Party shall be represented by a Lawyer.
6. The first meeting of the IEC shall be convened by the IEC by sending appropriate communication/notice to both the parties as soon as possible but not later than 30 days from the date of his/their appointment. The hearings in the Conciliation proceeding shall ordinarily be concluded within two (2) months and, in exceptional cases where parties have expressed willingness to settle the matter or there exists possibility of settlement in the matter, the proceedings may be extended by the IEC by a maximum of further 2 months with the consent of the Parties subject to cogent reasons being recorded in writing.
7. The IEC shall thereafter formulate recommendations for settlement of the Disputes supported by reasons at the earliest but in any case, within 15 days from the date of conclusion of the last hearing. The recommendations so formulated along with the reasons shall be furnished by the IEC to both the Parties at the earliest but in any case, within 1 month from the date of conclusion of the last hearing.
8. Response/modifications/suggestions of the Parties on the recommendations of the IEC are to be submitted to the IEC within time limit stipulated by the IEC but not more than 15 days from the date of receipt of the recommendations from the IEC.
9. In the event, upon consideration, further review of the recommendations is considered necessary, whether by BHEL or by the other Party, then, the matter can be remitted back to the IEC with

Signature Not Verified

Signed By: RAKESH  
KUMAR  
Location: BHEL, Goindwal  
Signing Date: 17.07.2023





## General Conditions of Contract (GCC) of MM Tenders

**BHARAT HEAVY ELECTRICALS LIMITED**

Industrial Valve Plant: 433, Industrial Complex,  
Goindwal Sahib, Dist. Tarn Taran,  
Punjab-143422 (INDIA)

request to reconsider the same in light of the issues projected by either/both the Parties and to submit its recommendations thereon within the following 15 days from the date of remitting of the case by either of the Parties.

10. Upon the recommendations by the Parties, with or without modifications, as considered necessary, the IEC shall be called upon to draw up the Draft Settlement Agreement in terms of the recommendations.
11. When a consensus can be arrived at between the parties only in regard to any one or some of the issues referred for Conciliation the draft Settlement Agreement shall be accordingly formulated in regard to the said Issue(s), and the said Settlement Agreement, if signed, by the parties, shall be valid only for the said issues. As regards the balance issues not settled, the parties may seek to resolve them further as per terms and conditions provided in the contract.
12. In case no settlement can be reached between the parties, the IEC shall by a written declaration, pronounce that the Conciliation between the parties has failed and is accordingly terminated.
13. Unless the Conciliation proceedings are terminated in terms of para 22 (b), (c) & (d) herein below, the IEC shall forward his/its recommendations as to possible terms of settlement within one (1) month from the date of last hearing. The date of first hearing of Conciliation shall be the starting date for calculating the period of 2 months.
14. In case of 3 members IEC, 2 members of IEC present will constitute a valid quorum for IEC and meeting can take place to proceed in the matter after seeking consent from the member who is not available. If necessary, videoconferencing may be arranged for facilitating participation of the members. However, the IEC recommendations will be signed by all members. Where there is more than one (1) Conciliator, as a general rule they shall act jointly. In the event of differences between the Members of IEC, the decision/recommendations of the majority of the Members of IEC shall prevail and be construed as the recommendation of the IEC.
15. The Draft Settlement Agreement prepared by the IEC in terms of the consensus arrived at during the Conciliation proceedings between the Parties shall be given by the IEC to both the parties for putting up for approval of their respective Competent Authority.
16. Before submitting the draft settlement agreement to BHEL's Competent Authority viz. the Board Level Committee on Alternative Dispute Resolution (BLCADR) for approval, concurrence of the other party's Competent Authority to the draft settlement agreement shall be obtained by the other party and informed to BHEL within 15 days of receipt of the final draft settlement agreement by it. Upon approval by the Competent Authority, the Settlement Agreement would thereafter be signed by the authorized representatives of both the Parties and authenticated by the members of the IEC.
17. In case the Draft Settlement Agreement is rejected by the Competent Authority of BHEL or the other Party, the Conciliation proceedings would stand terminated.





## General Conditions of Contract (GCC) of MM Tenders

### BHARAT HEAVY ELECTRICALS LIMITED

Industrial Valve Plant: 433, Industrial Complex,  
Goindwal Sahib, Dist. Tarn Taran,  
Punjab-143422 (INDIA)

18. A Settlement Agreement shall contain a statement to the effect that each of the person(s) signing thereto (i) is fully authorized by the respective Party(ies) he/she represents, (ii) has fully understood the contents of the same and (iii) is signing on the same out of complete freewill and consent, without any pressure, undue influence.
19. The Settlement Agreement shall thereafter have the same legal status and effect as an arbitration award on agreed terms on the substance of the dispute rendered by an arbitral tribunal passed under section 30 of the Arbitration and Conciliation Act, 1996.
20. Acceptance of the Draft Settlement Agreement/recommendations of the Conciliator and/or signing of the Settlement Agreement by BHEL shall however, be subject to withdrawal/closure of any arbitral and/or judicial proceedings initiated by the concerned Party in regard to such settled issues.
21. Unless otherwise provided for in the agreement, contract or the Memorandum of Understanding, as the case may be, in the event of likelihood of prolonged absence of the Conciliator or any member of IEC, for any reason/incapacity, the Competent Authority/Head of Unit/Division/Region/Business Group of BHEL may substitute the Conciliator or such member at any stage of the proceedings. Upon appointment of the substitute Conciliator(s), such reconstituted IEC may, with the consent of the Parties, proceed with further Conciliation into the matter either de-novo or from the stage already reached by the previous IEC before the substitution.
22. The proceedings of Conciliation under this Scheme may be terminated as follows:
- On the date of signing of the Settlement agreement by the Parties; or,
  - By a written declaration of the IEC, after consultation with the parties, to the effect that further efforts at conciliation are no longer justified, on the date of the declaration; or,
  - By a written declaration of the Parties addressed to the IEC to the effect that the Conciliation proceedings are terminated, on the date of the declaration; or,
  - By a written declaration of a Party to the other Party and the IEC, if appointed, to the effect that the Conciliation proceedings are terminated, on the date of the declaration.
  - On rejection of the Draft Settlement Agreement by the Competent Authority of BHEL or the other Party.





## General Conditions of Contract (GCC) of MM Tenders

### BHARAT HEAVY ELECTRICALS LIMITED

Industrial Valve Plant: 433, Industrial Complex,  
Goindwal Sahib, Dist. Tarn Taran,  
Punjab-143422 (INDIA)

23. The Conciliator(s) shall be entitled to following fees and facilities:

Sr. No.	Particulars	Amount
1	Sitting fees	Each Member shall be paid a Lump Sum fee of Rs 75,000/- for the whole case payable in terms of paragraph No. 27 herein below.
2	Towards drafting of settlement agreement	<p>In cases involving claim and/or counter-claim of up to Rs 5crores. Rs 50,000/- (Sole Conciliator)</p> <p>In cases involving claim and/or counter-claim of exceeding Rs 5 crores but less than Rs 10 crores. Rs. 75,000 (per Conciliator)</p> <p>In cases involving claim and/or counter-claim of more than Rs 10 crores. Rs 1,00,000/- (per Conciliator)</p> <p>Note: The aforesaid fees for the drafting of the Settlement Agreement shall be paid on Signing of the Settlement Agreement after approval of the Competent Authority or Rejection of the proposed Settlement Agreement by the Competent Authority of BHEL.</p>
3	Secretarial expenses	<p>Rs 10,000/- (one time) for the whole case for Conciliation by a Sole Member IEC.</p> <p>Where Conciliation is by multi member Conciliators –Rs 30,000/- (one time)- to be paid to the IEC</p>
4	Travel and transportation and stay at outstation	As per entitlement of the equivalent officer (pay scale wise) in BHEL.
	<p>i Retired Senior Officials of other Public Sector Undertakings (pay scale wise equivalent to or more than E-8 level of BHEL)</p>	
	Others	As per the extant entitlement of whole time Functional Directors in BHEL.

Signature Not Verified

Signed By: RAKESH

KUMAR

Location: BHEL, Goindwal

Signing Date: 17.07.2023





## General Conditions of Contract (GCC) of MM Tenders BHARAT HEAVY ELECTRICALS LIMITED

Industrial Valve Plant: 433, Industrial Complex,  
Goindwal Sahib, Dist. Tarn Taran,  
Punjab-143422 (INDIA)

5	Venue for meeting	Unless otherwise agreed in the agreement, contract or the Memorandum of Understanding, as the case may be, the venue/seat of proceedings shall be the location of the concerned Unit / Division / Region / Business Group of BHEL. Without prejudice to the seat/venue of the Conciliation being at the location of concerned BHEL Unit / Division / Region / Business Group, the IEC after consulting the Parties may decide to hold the proceedings at any other place/venue to facilitate the proceedings. Unless, Parties agree to conduct Conciliation at BHEL premises, the venue is to be arranged by either Party alternately.
---	-------------------	--

24. The parties will bear their own costs including cost of presenting their cases/evidence/witness(es)/expert(s) on their behalf. The parties agree to rely upon documentary evidence in support of their claims and not to bring any oral evidence in IEC proceedings.

25. If any witness(es) or expert(s) is/are, with the consent of the parties, called upon to appear at the instance of the IEC in connection with the matter, then, the costs towards such witness(es)/expert(s) shall be determined by the IEC with the consent of the Parties and the cost so determined shall be borne equally by the Parties.

26. The other expenditures/costs in connection with the Conciliation proceedings as well as the IEC's fees and expenses shall be shared by the Parties equally.

27. Out of the lump sum fees of Rs 75,000/- for Sitting Fees, 50% shall be payable after the first meeting of the IEC and the remaining 50% of the Sitting Fees shall be payable only after termination of the conciliation proceedings in terms of para 22 hereinabove.

28. The travelling, transportation and stay at outstation shall be arranged by concerned Unit as per entitlements as per Serial No. 3 of the Table at para 23 above, and in case such arrangements are not made by the BHEL Unit, the same shall be reimbursed to the IEC on actuals limited to their entitlement as per Serial No. 4 of the Table at Para 23 above against supporting documents. The IEC Member(s) shall submit necessary invoice for claiming the fees/reimbursements.

29. The Parties shall keep confidential all matters relating to the conciliation proceedings. Confidentiality shall extend also to the settlement agreement, except where its disclosure is necessary for purposes of its implementation and enforcement or as required by or under a law or as per directions of a Court/Governmental authority/ regulatory body, as the case may be.

30. The Parties shall not rely upon or introduce as evidence in any further arbitral or judicial proceedings, whether or not such proceedings relate to the Disputes that is the subject of the Conciliation proceedings:

Signature Not Verified

Signed By: RAKESH

KUMAR

Location: BHEL, Goindwal

Signing Date: 17.07.2023





## General Conditions of Contract (GCC) of MM Tenders

**BHARAT HEAVY ELECTRICALS LIMITED**

Industrial Valve Plant: 433, Industrial Complex,  
Goindwal Sahib, Dist. Tarn Taran,  
Punjab-143422 (INDIA)

- a. Views expressed or suggestions made by the other party in respect of a possible settlement of the Disputes;
  - b. admissions made by the other party in the course of the Conciliator proceedings;
  - c. proposals made by the Conciliator;
  - d. The fact that the other Party had indicated his willingness to accept a proposal for settlement made by the Conciliator.
31. The Parties shall not present the Conciliator(s) as witness in any Alternative Dispute Resolution or Judicial proceedings in respect of a Disputes that is/was the subject of that particular Conciliation proceeding.
32. None of the Conciliators shall act as an arbitrator or as a representative or counsel of a Party in any arbitral or judicial proceeding in respect of a Disputes that is/was the subject of that particular Conciliation proceeding.
33. The Parties shall not initiate, during the Conciliation proceedings, any arbitral or judicial proceedings in respect of a Disputes that is the subject matter of the Conciliation proceedings except that a Party may initiate arbitral or judicial proceedings where, in his opinion, such proceedings are necessary for preserving his rights including for preventing expiry of period of limitation. Unless terminated as per the provisions of this Scheme, the Conciliation proceedings shall continue notwithstanding the commencement of the arbitral or judicial proceedings and the arbitral or judicial proceedings shall be primarily for the purpose of preserving rights including preventing expiry of period of limitation.
34. The official language of Conciliation proceedings under this Scheme shall be English unless the Parties agree to some other language.





## General Conditions of Contract (GCC) of MM Tenders

**BHARAT HEAVY ELECTRICALS LIMITED**

Industrial Valve Plant: 433, Industrial Complex,  
Goindwal Sahib, Dist. Tarn Taran,  
Punjab-143422 (INDIA)

### Appendix-I of Annexure-X

#### FORMAT FOR SEEKING CONSENT FOR REFERRING THE DISPUTES TO CONCILIATION THROUGH IEC

To,

M/s. (Stakeholder's name)

**Sub: Resolution of the Disputes through conciliation by Independent Expert Committee (IEC).**

Ref: Contract No/MoU/Agreement/LOI/LOA& date \_\_\_\_\_.

Sir,

With reference to above referred Contract/MoU/Agreement/LOI/LOA, you have raised certain Disputes/claims. Vide your letter dated\_\_\_\_ you have requested BHEL to refer the Disputes/claims to IEC for Conciliation.

We are enclosing herewith Format (3) for giving consent and the terms and conditions of BHEL Conciliation Scheme, 2018 governing conciliation through IEC. You are requested to give your unconditional consent to the said terms and conditions of the Scheme by returning the same duly sealed and signed on each page. On receipt of your consent, matter will be put to the Competent Authority for consideration and decision.

Please note that BHEL has also certain claims against you (if applicable). BHEL reserves its right to agree or not to agree conciliation of the said disputes through BHEL and this letter is being issued without prejudice to BHEL's rights and contentions available under the contract and law.

Yours faithfully,

**Representative of BHEL**





## General Conditions of Contract (GCC) of MM Tenders

**BHARAT HEAVY ELECTRICALS LIMITED**

Industrial Valve Plant: 433, Industrial Complex,  
Goindwal Sahib, Dist. Tarn Taran,  
Punjab-143422 (INDIA)

### Appendix-II of Annexure-X

#### FORMAT FOR GIVING CONSENT BY CONTRACTOR/VENDOR/CUSTOMER/COLLABORATOR/CONSORTI UM PARTNERS FOR REFERRING THE DISPUTES TO CONCILIATION THROUGH IEC

To,

BHEL

.....

**Sub: Resolution of Disputes through Conciliation by Independent Expert Committee (IEC).**

Ref: Contract/MoU/Agreement/LOI/LOA No

& date \_\_\_\_

With reference to above referred contract, our following bills/invoices/claims submitted to BHEL are still unpaid giving rise to Disputes:

SL. no.	Claim Description	Bill submitted to BHEL (no. and date)	Amount of the bill/claim	Amount received from BHEL	Outstanding Amount

Accordingly, we request you to kindly refer the Disputes in respect of above claims to IEC for Conciliation.

We hereby agree and give our unconditional consent to the terms and conditions of BHEL Conciliation Scheme, 2018 governing conciliation through IEC. We have signed the same on each page and enclosed it for your consideration.

Yours faithfully,

**(Signature with stamp)**

**Authorized Representative of Contractor  
Name, with designation Date**





## General Conditions of Contract (GCC) of MM Tenders

**BHARAT HEAVY ELECTRICALS LIMITED**

Industrial Valve Plant: 433, Industrial Complex,  
Goindwal Sahib, Dist. Tarn Taran,  
Punjab-143422 (INDIA)

### Appendix-III of Annexure-X

#### STATEMENT OF CLAIMS/COUNTER CLAIMS TO BE SUBMITTED TO THE IEC BY BOTH THE PARTIES

1. Chronology of the Disputes
2. Brief of the Contract/MoU/Agreement/LOI/LOA
3. Brief history of the Disputes:
4. Issues:
5. Details of Clam(s)/Counter Claim(s):

Sl. No.	Description of claim(s)/Counter Claim	Amount (in INR) Or currency applicable in the contract	Relevant contract clause

6. Basis/Ground of claim(s)/counter claim(s) (along with relevant clause of contract)

**Note**– The Statement of Claims/Counter Claims may ideally be restricted to maximum limit of 20 pages. Relevant documents may be compiled and submitted along with the statement of Claims/Counter Claims. The statement of Claims/Counter Claims is to be submitted to all IEC members and to the other party by post as well as by email.



**Tender Enquiry No. 2324-038E Dated 05.08.2023 Due date 16.08.2023**

**Tender Description:** Supply of Foundation Bolts

**(Annexure- P)**

**Confirmations of Special Terms :**

<b>SPECIAL TERMS</b>		<b>CONFIRMATION BY BIDDER</b>
<b>Delivery Destination and Scope of Unloading as per Tender Special Term S5</b>	NTPC Talcher Project Site Address:  Construction Manager, BHEL Site Office, 2X660 MW NTPC Talcher, Distt. Angul - 759107 Odisha, India  <b>Un-loading</b> of material at Talcher Site shall be arranged by BHEL site.	<b>Yes</b>
<b>Differential Freight (as per Tender Special Term S7)</b>		<b>Yes</b>
<b>Packing of Material (as per Tender Special Term S8)</b>		<b>Yes</b>
<b>Rates quoted by the bidder against this tender is Net of Taxes</b>		<b>Yes</b>
<b>Undertaking that Bidder have read and understand all Drawings/QCP and other terms and conditions and comply the same.</b>		<b>Yes</b>

Authorized Signatory with seal

Place:

Date:

2-FM-011-00003

DRAWING NO.

FOR TOLERANCES OF UNTOLERANCED DIMENSIONS DURING MANUFACTURE REFER PLANT STD. NO TP 023 0299

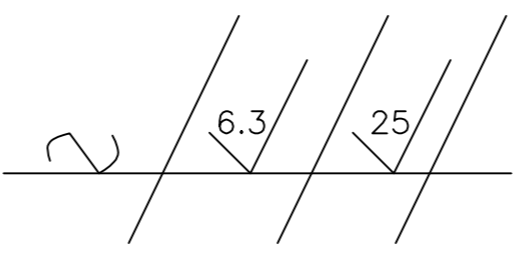
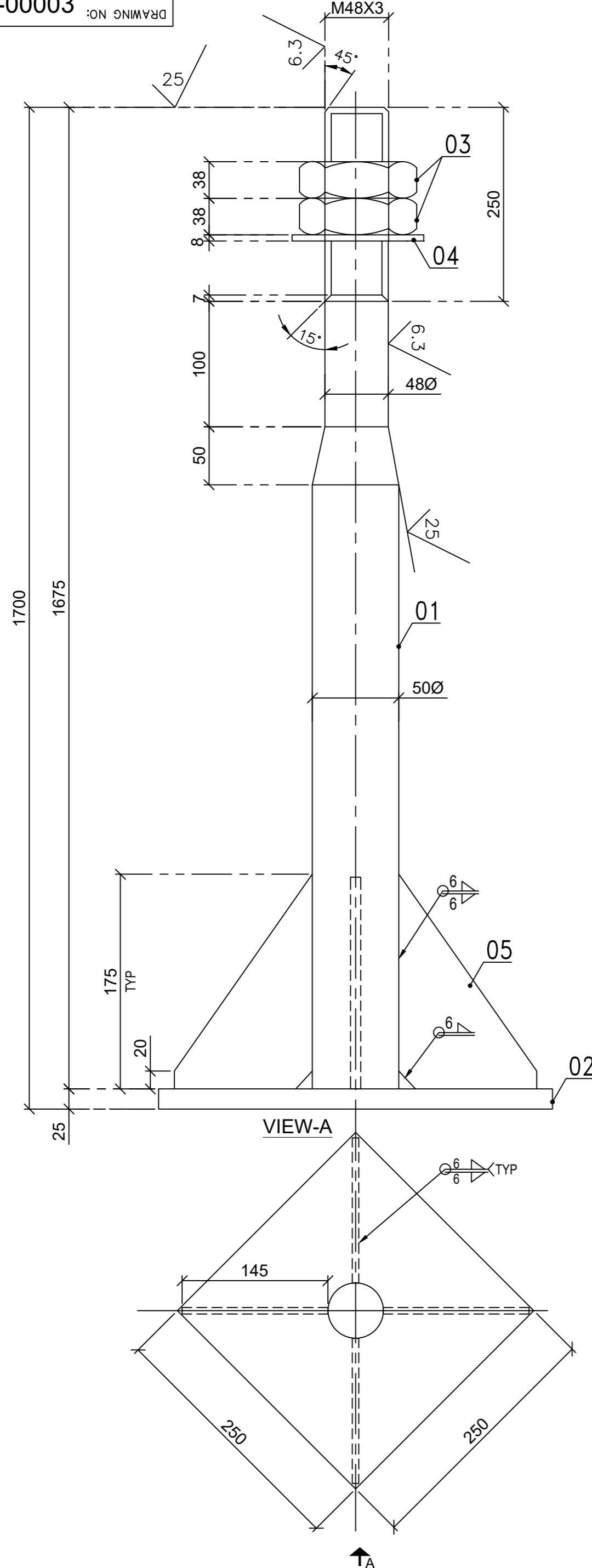

SIZE AND TYPE OF WELD	TYPE OF ELECTRODE	TOTAL LENGTH OF WELD IN MTRS
6 FILLET	E 7018	2.280

**NOTES :-**

- 01) FOUNDATION BOLT SHOULD NOT BE PAINTED.
- 02) THREAD ENDS OF BOLT TO BE COATED WITH RUST PROOF OIL AND PROTECTED AGAINST CORROSION .
- 03) MANUFACTURING REQUIRMENTS SHALL BE AS PER RELAVENT Q.C.P .
- 04) MATERIALS AND OTHERS REQUIREMENTS ARE GIVEN PER ASSEMBLY ONLY.

VARIANT NUMBER	ITEM NUMBER	DESCRIPTION	STD	DRAWING NUMBER	ITEM NO	MATERIAL CODE	A/C/P	UNIT	UNIT WEIGHT	CS	ZONE
VAR NO						MATERIAL SPECN		DI	QUANTITY		
	05	PLATE 8 175 X 145				15011027 IS2062E250A			0.888 4		
	04	WASHER PUNCHED A48				4140800045 IS 2016			0.224 1		
	03	HEX NUT GR C M48X3				4130430048 BPS-41304			0.870 2		
	02	PLATE 25 250X250				150110810000 IS2062E250A			12.266 1		
	01	ROD DIA 50 1700				150040230000 IS2062E250A			26.197 1		

REV	DATE	ALTERED : P.S.PANDIAN	REV	DATE	ALTERED : P.S.PANDIAN
04	07-09-2022	CHD & APPD : VSRK	02	29-06-2022	CHD & APPD : VSRK
04	07-09-2022	CHD & APPD : VSRK	01	25-04-2022	CHD & APPD : P.S.P/ K.S.P
04	07-09-2022	CHD & APPD : VSRK	01	25-04-2022	CHD & APPD : T.HARI/VSRK

CAUTION: The information on this document is the property of BHARAT HEAVY ELECTRICALS LTD. It must not be used directly or indirectly in any way detrimental to the interest of the company.

TYPE OF PRODUCT OR NAME OF CUSTOMER/PROJECT

**Bharat Heavy Electricals Ltd**  
UNIT: HIGH PRESSURE BOILER PLANT  
TIRUCHIRAPALLI - 620014

DRN	K.S.PANDIAN	SIGNATURE	DATE
CHD	T.HARI		23-12-2021
APPD	VSRK		24-12-2021

DEPT: ST  
CODE: 122  
ALL DIMENSIONS ARE IN MM  
PROJECTION: N.T.S  
SCALE: N.T.S  
WEIGHT (Kg):  
REF TO ASSY / OLD DWG

TITLE: **FOUNDATION BOLT 50 DIA-1700 LONG**

DRAWING NO : **2-FM-011-00003**

REV: **04**

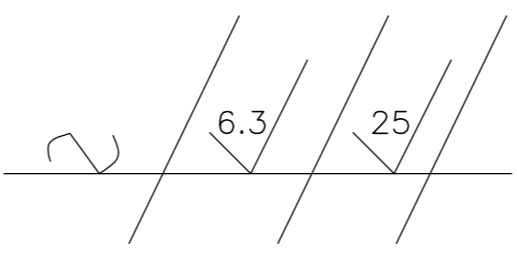
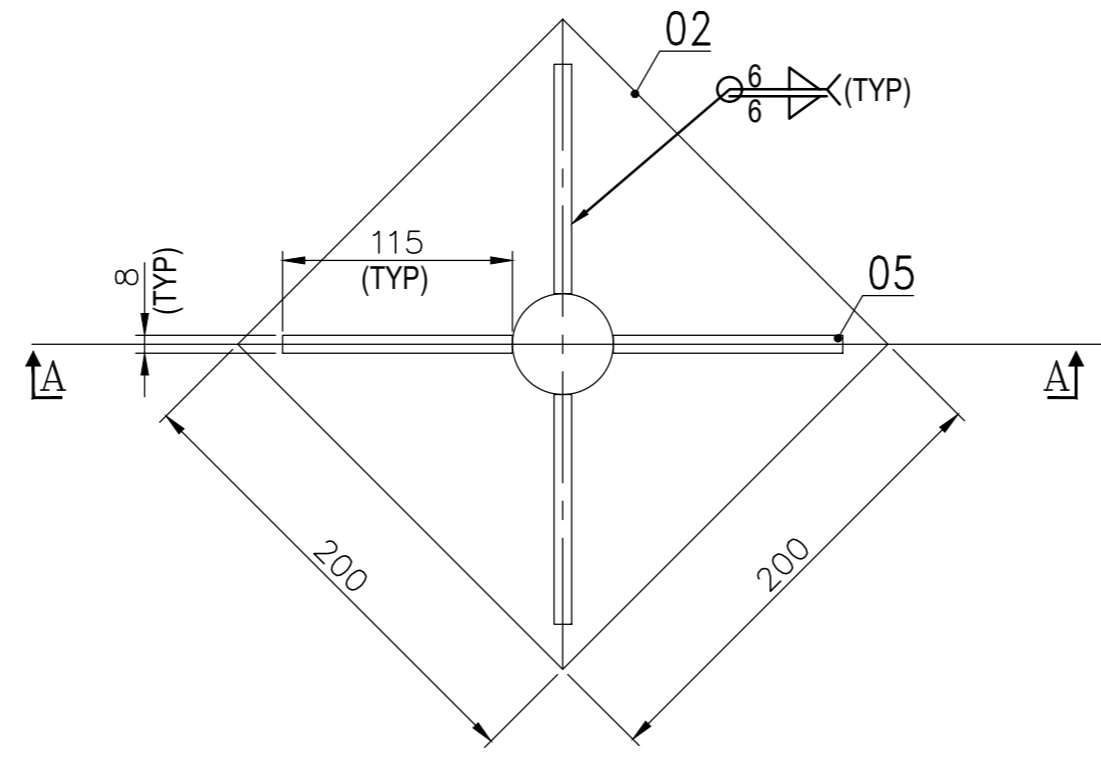
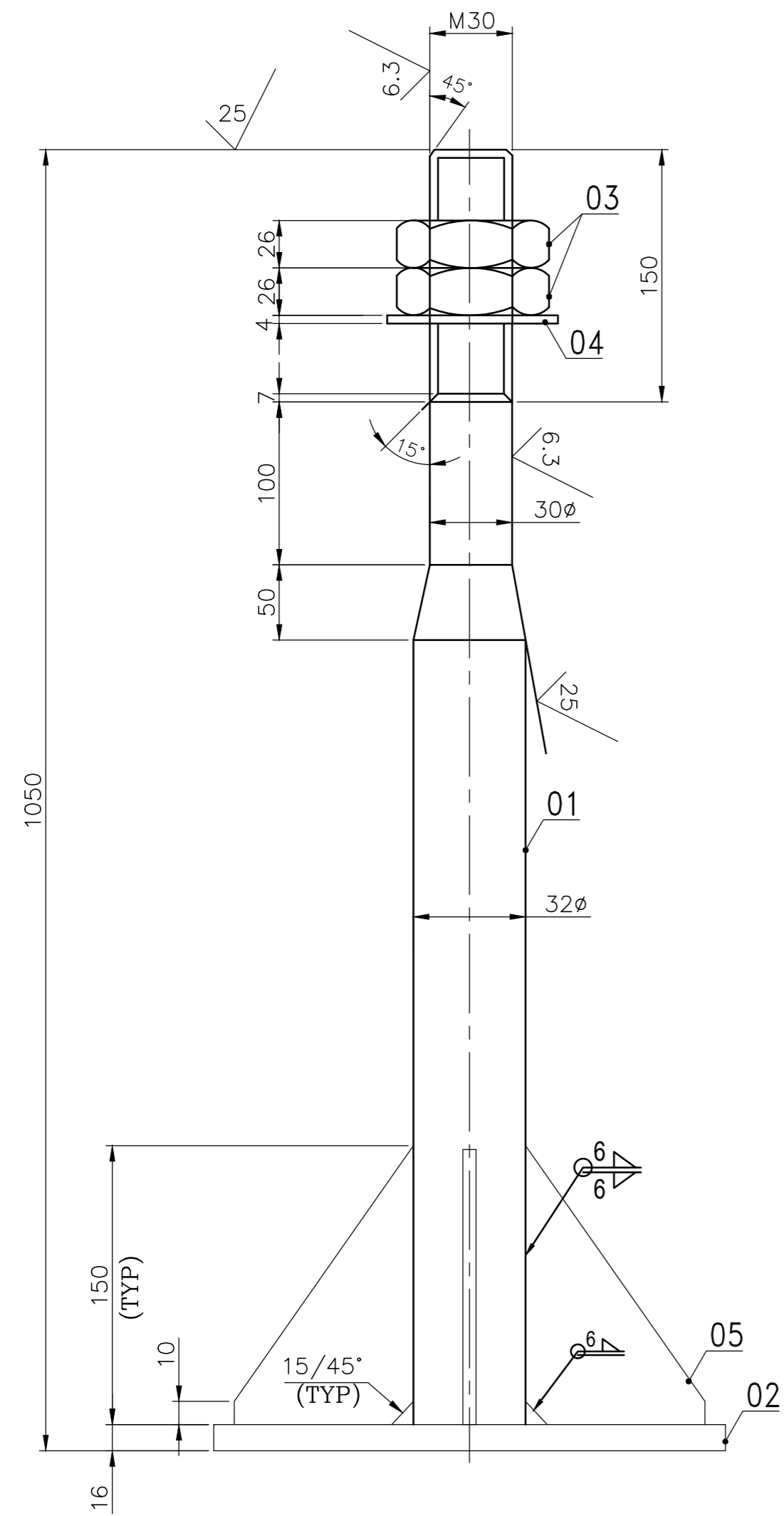

SIZE AND TYPE OF WELD	TYPE OF ELECTRODE	TOTAL LENGTH OF WELD IN MTRS
6 FILLET	E 7018	2.260

**NOTES :-**

- 01) FOUNDATION BOLT SHOULD NOT BE PAINTED.
- 02) THREAD ENDS OF BOLT TO BE COATED WITH RUST PROOF OIL AND PROTECTED AGAINST CORROSION .
- 03) MANUFACTURING REQUIRMENTS SHALL BE AS PER RELAVENT Q.C.P .
- 04) MATERIALS AND OTHERS REQUIREMENTS ARE GIVEN PER ASSEMBLY ONLY.

VARIANT NUMBER	ITEM NUMBER	DESCRIPTION	STD	DRAWING NUMBER	ITEM NO	MATERIAL CODE	A/C/P	UNIT	UNIT WEIGHT	CS	ZONE
VAR NO		MATERIAL SPECN					DI	QUANTITY			
	05	PLATE 8 115 X 150				15011027 IS2062E250A		No	0.577 4		
	04	WASHER PUNCHED A30				4140800030 IS 2016		No	0.050 1		
	03	HEX NUT GR C M30				4130400030 IS1364 P3		No	0.231 2		
	02	PLATE 16 200X200				15011026 IS2062E250A		No	5.024 1		
	01	ROD DIA 32 1034				15004018 IS2062E250A		No	6.520 1		

SECTION-AA

REV 01	DATE 07.07.2022	ALTERED : S.SETHUPATHI
ZONE 01	ITEM No.05 WEIGHT CORRECTED.	

CAUTION: The information on this document is the property of BHARAT HEAVY ELECTRICALS LTD. It must not be used directly or indirectly in any way detrimental to the interest of the company.	TYPE OF PRODUCT OR NAME OF CUSTOMER/PROJECT			
	Bharat Heavy Electricals Ltd UNIT: HIGH PRESSURE BOILER PLANT TIRUCHIRAPALLI - 620014		DRN	NAME
	355-054 DEPT ST CODE 122		CHD	SIGNATURE
	ALL DIMENSIONS ARE IN MM PROJECTION SCALE N.T.S WEIGHT (Kg) 14.366		APPD	DATE
TITLE			REF TO ASSY / OLD DWG	
FOUNDATION BOLT 32 DIA. 1050 LONG			DRAWING NO : 2-FM-011-00010	
			REV	01

2-FM-011-00053  
DRAWING NO.

FOR TOLERANCES OF UNTOLERANCED DIMENSIONS DURING MANUFACTURE REFER PLANT STD. NO TP 023 0299

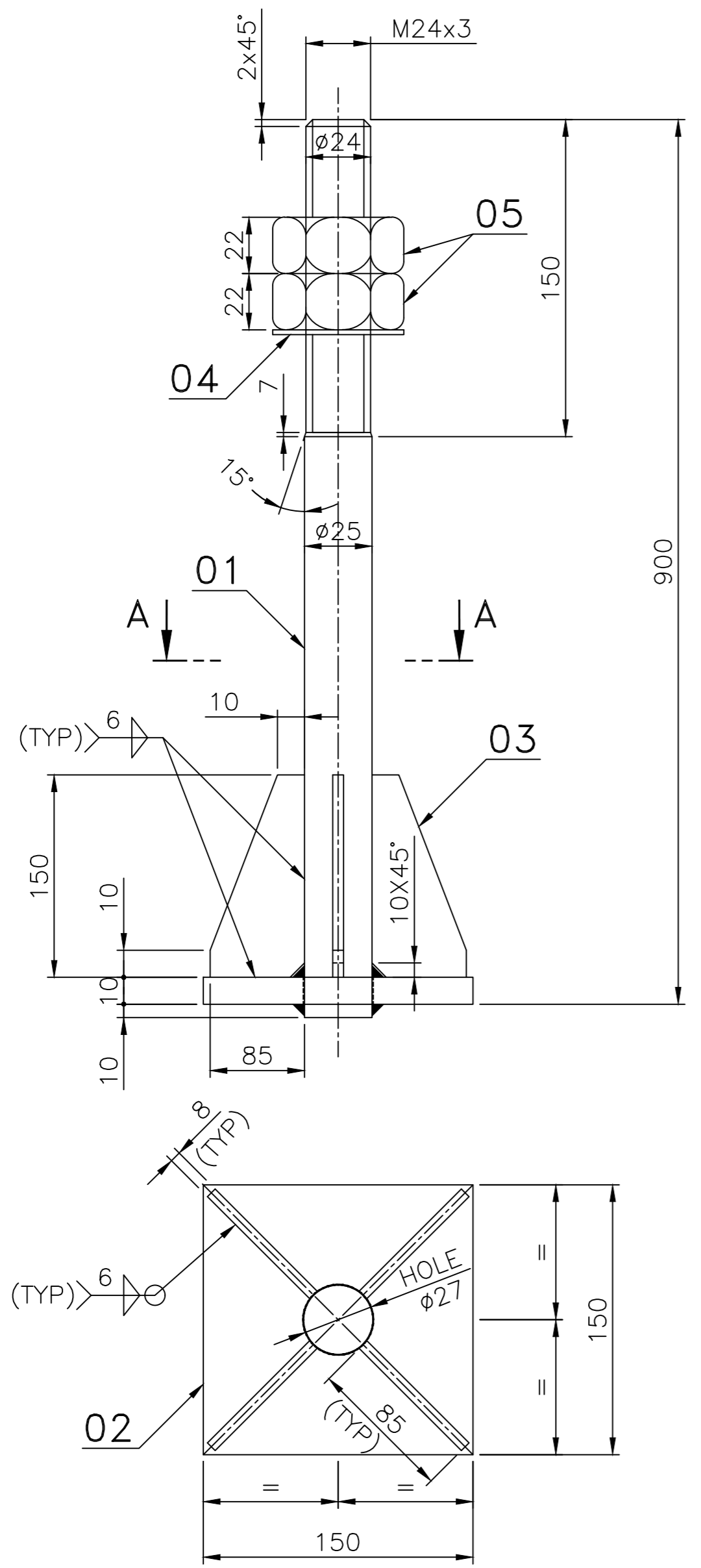

**NOTES:-**

01. FOUNDATION BOLT SHOULD NOT BE PAINTED.
02. THREAD ENDS OF BOLT TO BE COATED WITH RUST PREVENTIVE LUBRICANT AND COVERED BY TAR IMPREGNATED GUNNY CLOTH.
03. FOUNDATION BOLT THREAD PITCH IS TO BE FOLLOWED IN LINE WITH THE NUT.
04. BOLT AND NUT ARE TO BE SHOP ASSEMBLED.
05. MANUFACTURING REQUIREMENT SHALL BE AS PER APPLICABLE Q.C.P.
06. MATERIAL AND OTHER REQUIREMENTS ARE GIVEN PER ASSEMBLY ONLY.

VARIANT NUMBER	ITEM NUMBER	DESCRIPTION	STD	DRAWING NUMBER	ITEM NO	MATERIAL CODE	A/Q/P	UNIT	UNIT WEIGHT	CS	ZONE
					VAR NO	MATERIAL SPECN		DI	QUANTITY		
	05	HEX NUT M24				413040002400	No		0.110		
						CL4-IS1363P3			2		
	04	PUNCHED WASHER M24				414080002400	No		0.030		
						IS2016-A			1		
	03	PLATE 8 85x150				15011027	No		0.471		
						IS2062Fe410A			4		
	02	PLATE 10 150X150				152110980000	No		1.766		
						IS2062Fe410A			1		
	01	ROD DIA.25 910				150040270000	No		3.507		
						IS2062Fe410A			1		

CAUTION: The information on this document is the property of BHARAT HEAVY ELECTRICALS LTD. It must not be used directly or indirectly in any way detrimental to the interest of the company.	TYPE OF PRODUCT OR NAME OF CUSTOMER/PROJECT					
	Bharat Heavy Electricals Ltd UNIT: HIGH PRESSURE BOILER PLANT TIRUCHIRAPALLI - 620014		DRN	R.GOVINDASAMY	SIGNATURE	DATE
			CHD	M.PADMANABAN		08.04.2022
			APPD	K.RAJIVGANDHI		08.04.2022
DEPT	PE/FB	ALL DIMENSIONS ARE IN MM	PROJECTION	SCALE	WEIGHT (Kg)	REF TO ASSY / OLD DWG
CODE	122			N.T.S.	7.404	---
TITLE					DRAWING NO :	REV
FOUNDATION BOLT 25 DIA. 900mm LONG					2-FM-011-00053	00

REV	DATE	ALTERED :
01		CHD & APPD :
ZONE		

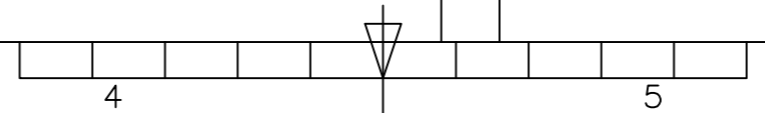

2-FM-011-00002  
DRAWING NO.

FOR TOLERANCES OF UNTOLERANCED DIMENSIONS DURING MANUFACTURE REFER PLANT STD. NO TP 023 0299

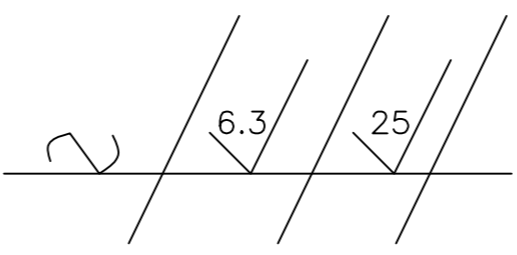
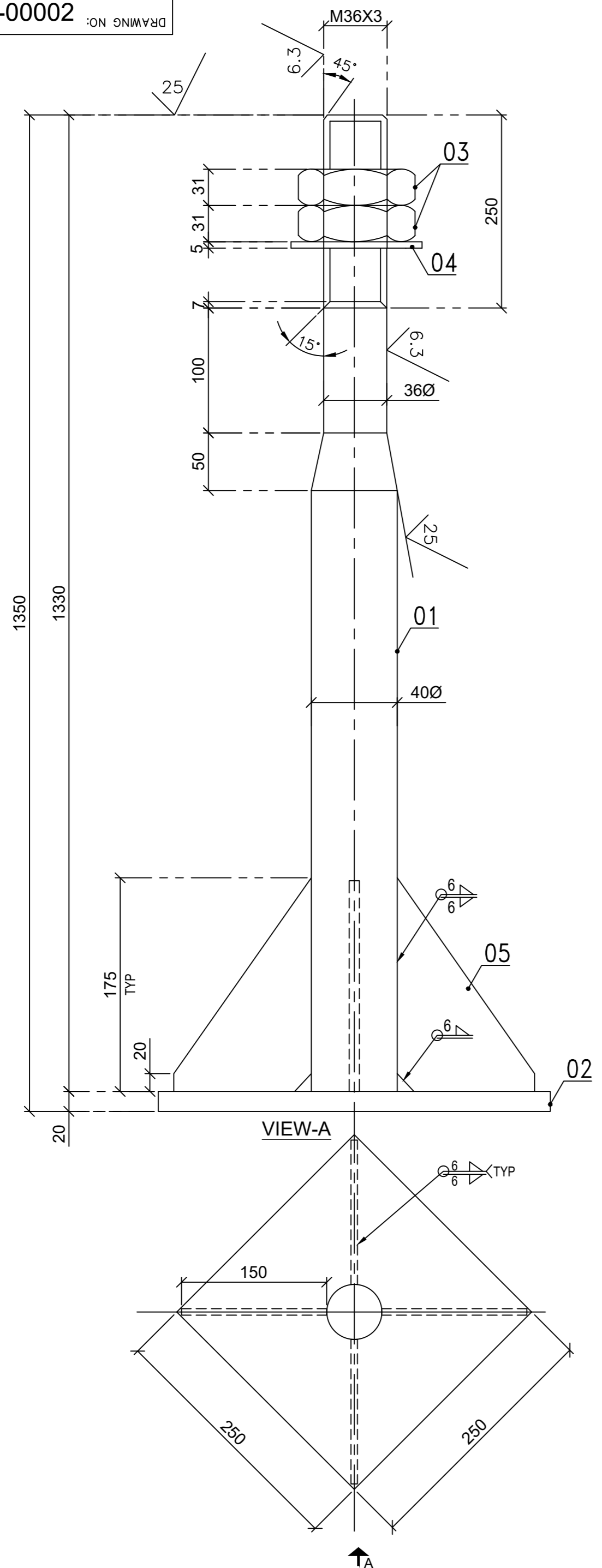

SIZE AND TYPE OF WELD	TYPE OF ELECTRODE	TOTAL LENGTH OF WELD IN MTRS
6 FILLET	E 7018	2.280

**NOTES :-**

- 01) FOUNDATION BOLT SHOULD NOT BE PAINTED.
- 02) THREAD ENDS OF BOLT TO BE COATED WITH RUST PROOF OIL AND PROTECTED AGAINST CORROSION .
- 03) MANUFACTURING REQUIRMENTS SHALL BE AS PER RELAVENT Q.C.P .
- 04) MATERIALS AND OTHERS REQUIREMENTS ARE GIVEN PER ASSEMBLY ONLY.

VARIANT NUMBER	ITEM NUMBER	DESCRIPTION	STD	DRAWING NUMBER	ITEM NO	MATERIAL CODE	A/C/P	UNIT	UNIT WEIGHT	CS	ZONE
VAR NO						MATERIAL SPECN		DI	QUANTITY		
	05	PLATE 8 175 X 150				15011027 IS2062E250A			0.918 4		
	04	WASHER PUNCHED A39				4140800036 IS 2016			0.087 1		
	03	HEX NUT GR C M36X3				4130100036 IS1364 P3			0.396 2		
	02	PLATE 20 250X250				15011150 IS2062E250A			9.813 1		
	01	ROD DIA 40 1350				15004007 IS2062E250A			13.311 1		

REV 01	DATE 13-07-2022	ALTERED : K.S.PANDIAN
ZONE	IT NO. 02 QTY REVISED.	

CAUTION: The information on this document is the property of BHARAT HEAVY ELECTRICALS LTD. It must not be used directly or indirectly in any way detrimental to the interest of the company.	TYPE OF PRODUCT OR NAME OF CUSTOMER/PROJECT			
	Bharat Heavy Electricals Ltd UNIT: HIGH PRESSURE BOILER PLANT TIRUCHIRAPALLI - 620014		DRN	K.S.PANDIAN
	355-054 DEPT ST CODE 122		SCALE	N.T.S
	ALL DIMENSIONS ARE IN MM PROJECTION SCALE N.T.S		WEIGHT (Kg)	REF TO ASSY / OLD DWG
TITLE			DRAWING NO :	
FOUNDATION BOLT 40 DIA-1350 LONG			2-FM-011-00002	
			REV	01



BHARAT HEAVY ELECTRICALS LIMITED  
TIRUCHIRAPPALLI - 620 014  
QUALITY ASSURANCE DEPARTMENT

AMENDMENT TO QUALITY WORK INSTRUCTIONS (QWI)

QWI NO: QCP:002 REV: 05

AMENDMENT SL NO: A1 DATE: 15.09.2018

**DESCRIPTION: QUALITY CONTROL PROCEDURE FOR NON- PRESSURE PARTS**

Clause No.	Existing...	Amended as...	Remarks / Basis for Amendment
4.1.7	Heat treatment shall be done after shearing for P3 materials for $t > 12.5\text{mm}$ and for P4 and P5 materials of all thickness with a holding time of 15 minutes minimum	Heat treatment shall be done after shearing for P3,P4 materials $t > 12.5\text{mm}$ and for P5 materials $t > 10\text{mm}$ .	Standard practice of BHEL is retained.
NOTE	The above-mentioned changes will be incorporated in the QWI during the next revision of the document.		
Prepared by: M.Jeyaram		Approved by: J V V Aruna Kumar	
 Signature & Dt: 15.09.18		 Signature & Dt: 15.09.18	

**BHARAT HEAVY ELECTRICALS LIMITED,  
TIRUCHIRAPPALI 620 014  
QUALITY ASSURANCE DEPARTMENT**

**QUALITY CONTROL PROCEDURE FOR  
NON- PRESSURE PARTS**

**QCP: 002 / 05**

Prepared by Quality Assurance	<i>M.Jeyaram</i> <i>M. Jeyaram</i> 07/3/18
REVIEWED BY	SIGNATURE
ENGINEERING ( <i>M. Shanmugam</i> )	<i>Shanmugam</i> 07/03/2018
OUT SOURCING ( <i>M. Arunmozhi Devan</i> )	<i>mc</i> — 7/3/18
QUALITY CONTROL ( <i>A. Rajasekar</i> )	<i>sh</i> 7/3/18
QUALITY ASSURANCE ( <i>J V V Aruna kumar</i> )	<i>J V V Aruna kumar</i> 7/3/2018

Revision No.	Date	Approved by	Signature
05	07/03/18	AGM / QA&BE	<i>Arun</i> 7/3/18
04	08/12/11	DGM/QA	-----
03	10/06/10	SM/QA	
02	24/04/04	SDGM/QA	
01	01/01/95	SM/QA	
00	01/04/93	SM/QA	

*Proprietary Data – For Internal Use only*

**RECORD OF REVISIONS**

Rev No...	Clause No	Details of revision
00	--	This document consolidates all the general requirements and technical disciplines covered in the various previous
01	--	All amendments issued has been regularized and editorial correction made for better clarity. Scope of machining added in this document.
02		Editorial correction made for better clarity. Scope of machining added in this document.
03		Shaded clauses & Type of joints for base plates incorporated. PWHT temperature for P4 material revised.
04		P91 & 92 Bar process requirements added.
05	1.0	Scope modified
	3.0	New materials added.
	3.6.3	TC added.
	4.1.7	Minimum holding time specified.
	4.1.8	P3 and P5 material requirements added.
	4.1.8.1	Alternate method of grinding for gas cut edges included
	4.3.1.3	Newly added
	4.3.2.2	Root gap for SAW defined.
	4.3.3.3	Preheat area defined.
	4.3.13	1:2.5 taper specified
	4.5.3	Hot correction temperatures given for alloy steels
	4.6.7	Table added
	4.6.8.1	Thickness for soaking time defined
	4.6.8.2	Effective thickness for combination of groove and fillet defined as per AWS D1.1 2015
	4.6.11	Width of heat band defined
	4.6.11.1	Width of insulation band defined
	8.1	Machined/bolted surface painting defined
		Fig-1 added
		Annexure A and B added for better clarity

## 1.0 SCOPE

- 1.1 This procedure details out the process control and quality requirements for manufacture of Non Pressure Parts **in addition to the requirements specified in SQPs and SIPs of the respective products/projects.**

## 2.0 REFERENCE DOCUMENTS

- 2.1 AWS D.1.1, D1.6, IS 7215 and **GE:M&P 5.11.2.3(b), 5.11.2.1(e) & 5.11.2.2(e)** as guidelines.

## 3.0 MATERIALS

- 3.1 CLASSIFICATION OF MATERIALS (commonly used):

<u>P No. Group</u>	<u>Specifications</u>
P1 - Group 1 -	Carbon steel : <b>IS 2062/E250A &amp; E250B0,BR&amp; C,</b> SA 515 Gr 60.SA106 GrB,A36, A53 GrB,
P1 - Group 2 -	H.Strength CS :SA105, SA 515 Gr 70, SA 299, SA 516 Gr 70,
P3 - Group 1	SA 588
P3- Group 2	SA 204 Gr B
P4 -	SA 387 Gr 11 & Gr 12, SA 182 Gr F 11 & F 12.
P5 A- Gr 1(LAS),	SA 387 Gr 22 Cl.1&CL.2, SA 182 Gr F 22
P5 B- Gr1( LAS)	SA387 Gr5 CL.1 &SA387 Gr.9 Cl.2
P15E Gr1	SA182 F91,F92,SA387 Gr91,Gr92, SA 335 P91,P92 SA213 T91,T92 ,SA234 WP91,WP92 & SA 336 F91,F92
P6 -	SA 240-410,429
P8 - Stainless steel	SA 240 - 304 ,309,310, 316, 321, 347 & 253MA
IS	<b>IS 2062/E350A,B0,BR&amp; C, E450BR, Fe410, IS3589,IS1079 , IS513 TYPE D,</b> IS 1239, IS 1161 YST 240.
EN	BS EN10025-2, EN10025-3

Any other materials as specified in the drawings.

- 3.2 Raw materials used shall conform to the relevant specification as given in drawings and applicable TDC/PO. Any substitution of materials shall be done only with prior approval of engineering through applicable documents. Where subcontractors procure the raw materials, the same shall have valid test certificates.
- 3.3 Raw materials shall be free from visual defects like cracks, seams, laps, laminations, heavy pitting etc. When defects are noticed in visual inspection the same shall be confirmed using appropriate NDE techniques and repaired using applicable approved process .
- 3.4 All materials are procured with permitted dimensional tolerances of the material specifications and / or TDC. Wherever required, the raw materials shall be corrected prior to fabrication to achieve the required product tolerances.
- 3.5 Customer supplied materials are to be verified as per SP 0626.
- 3.6 The requirements of material traceability shall be as indicated in the respective drawings.
- 3.6.1 Product Attest “P” items indicated as in drawings are traceable to the test certificates and identified with material Specification, grade and melt number by stamping.
- 3.6.2 CERTIFIED items indicated as "C" in drawings are traceable to material Specification / grade only and identified by stamping / engraving / stenciling / painting.

- 3.6.3 Raw materials not covered by the above shall be identified by its W.O.No / Material code / Specification / grade by painting / stenciling / engraving. **The Test certificates for raw materials shall be maintained by OVM vendors.**
- 3.6.4 All subdeliveries shall be identified by its material code by painting or through name plates / tags.
- 3.7 When materials ( including stock) are to be upgraded for special contract requirements QC shall ensure that the respective specification, **CQR** and contract TDC ( as applicable) are complied.

#### 4.0 FABRICATION

##### 4.1 MARKING, CUTTING AND PREPARATION

- 4.1.1 Raw material shall be marked and cut to size by shearing, machining, saw cutting, flame or plasma (for SS materials) cutting. Flame cut edges shall be cleaned to remove slag. Uneven edges shall be dressed by grinding. Gas cutting notches shall be filled up by grinding the notches smoothly for welding using compatible electrodes and ground before taking up for further fabrication.
- 4.1.2 Wherever raw materials supplied / available are not sufficient for the sizes required, the same can be built up using the splicing either by groove weld/fillet weld sufficient to hold the parts in place instructions given in the respective SQPs/ Drawings/DCN (Incl. Production Notes)
- 4.1.3 Layout for size and shape shall be marked before cutting (for other than CNC applications) The tolerance for marking shall be maintained within + 2mm unless otherwise specified. The diagonal difference shall be within 3 mm.
- 4.1.4 The markings shall be punched at convenient intervals and bordered with white paint.
- 4.1.5 Stainless Steel (SS) materials shall be cut using plasma cutting or shearing only. Any further dressing/ grinding of cut surfaces should be done with separate and clean abrasive wheels.
- 4.1.5.1 The cut edges should be smoothly ground.
- 4.1.5.2 Notches above 3 mm or 20 % 'T' shall be thoroughly cleaned and welded by using a qualified WPS and examined visually and by LPI . The repaired surfaces are to be cleaned to bright metal surface.
- 4.1.6 Clip / Cleat angles of carbon steel above **12** mm thick used for beam connections which are sheared to length shall require heat treatment. Shearing /Flame/gas cutting is prohibited on Gr 91 and Grade 92 materials. Use only bandsaw for cutting of Gr91&92 materials. However for plates use plasma/waterjet/ bandsaw only
- 4.1.7 Heat treatment shall be done after shearing for **P3** materials for  $t > 12.5\text{mm}$  and for P4 and P5 materials of **all thickness with a holding time of 15 minutes minimum.**
- 4.1.8 The requirements of preheat for gas cutting are as follows:
- |                                  |                        |                |
|----------------------------------|------------------------|----------------|
| Carbon steel                     | $t \leq 50\text{mm}$ : | : Nil          |
| Carbon steel                     | $t > 50\text{mm}$ :    | : 100 ° C.min. |
| Alloy steel ( <b>P3&amp;P4</b> ) | $t \leq 25\text{mm}$ : | : Nil          |
| Alloy steel ( <b>P3&amp;P4</b> ) | $t > 25\text{mm}$ :    | : 150 ° C      |

## Alloy steel (P5)

Sl no	P5 Material- thickness	Preheat temperature
1	t<13mm	120 °C.
2	For t=13 upto 25mm	150 °C.
3	t>25mm	200 °C.

Stainless steel Not applicable

- 4.1.8.1 Stress relieving for gas cut edges shall be as follows. **Alternatively, the cut surface can be ground / machined upto 3 mm to remove HAZ and checked by LPI/MPI.**

Material	Thickness	Heat treatment cycle
P1	> 50 mm	600 ° - 650 ° C for 15 minutes
P3	> 16 mm	620-650 ° C for 15 minutes.
P4	> 16 mm	650 ° – 700 ° C for 15 minutes.Furnace cool
P5	All	680 ° - 730 ° C for 15 minutes. Furnace cool
SS (plasma)	Any	Not required

For materials other than P5, P15E Gr 1(Grade 91) and Grade 92 this heat treatment may be clubbed with the final heat treatment of the product.

- 4.1.9 The prepared plates shall be visually inspected and repaired if required as per SIP:NP:06.
- 4.1.10 The raw materials after cutting shall be identified with relevant WO No., DU No., Part No. and Material Spec / Grade (transferred).

## 4.2 FORMING

- 4.2.1 Before forming , proper cutting plan (Drawing dimensions with process allowances) shall be prepared and cleared by the concerned agency. Forming shall be done using proper tooling free from damages. Method of forming and work centre shall be identified in OPS / relevant QWI refered in PO.
- 4.2.2 Built up (Forming) operations for Beams and columns shall be done done by suitable Fixtures,Machines ,WPS & other accessories required for forming. All the Forming operations of sheets / plates shall be done by rolling / pressing. For shell formed components Circularity of rolled shells shall be checked using templates (of length > ¼ of ID).
- 4.2.3 Suitable nonmetallic padding shall be provided while forming of stainless steels to avoid contamination.
- 4.2.4 All formed /Built up components shall be checked for orientation, angle, and other dimensions as per drg. All formed parts shall have smooth finish and shall be free from bends, folds and sudden transitions.
- 4.2.5 Minimum thickness after forming shall be ensured whenever specified in drg.
- 4.2.6 **Forming of U-ROD( Gr91&92)**
- 4.2.6.1 Identify, mark and cut the rod using bandsaw to a length of equivalent to the arc length indicated in the drawing with two arm length(upto butt joint) +20mm.

- 4.2.6.2 Mark the centre of the rod with a heat resistant chalk to be visible after heating. For temperature and other details refer the SQP:NP:15(Latest)
- 4.2.6.3 Remove the “U”rod and air cool to room temperature.
- 4.2.6.4 Visually inspect the bend surface and check dimensions and ensure no surface imperfections.
- 4.2.6.5 Normalizing and tempering of “U”Rods to be done within 72 hours after pressing/bending operation.(Ref.SQP:NP:15(latest)
- 4.2.6.6 Shot blast the “U”Rod to remove scaling and check the dimension. Conduct LPI/Wet MPI and ensure no surface indications.
- 4.2.6.7 Mark and cut the limbs of “U” rods such that the straight portion shall be as per drawing from the tangent point.
- 4.2.6.8 Edge prepare the “U”rod s for butt joint preparation as shown in the drawing by machining No gouging and grinding is allowed.
- 4.2.6.9 For Detailed operation of cold and hot forming of Gr 91 &Gr 92 materials refer SQP:NP:15(latest)

#### 4.2.7 **Threading of “U”Rods**

- 4.2.7.1 Mark and cut the rods equivalent to the straight portions as shown in the drawings.
- 4.2.7.2 Threading to be done on one end of the rod to thread size as mentioned in the drawing/ SQP:NP15(latest).
- 4.2.7.3 Edge prepare the other end of the rods by machining for butt welding as shown in the drawing.
- 4.2.7.4 Tolerances for formed components when not specified in drg. Shall be as follows
- a) St.Length / Dia, : + 1 mm/M, 5 mm Max  
Width & Height
  - b) Verticality : 1 mm / M, 5 mm Max
  - c) Squareness : 1 mm / M of length / Dia
  - d) Straightness : 1 mm / M, 5 mm Max
  - e) Radius : + 5 mm
  - f) Bend Angle : + 2°
  - g) Ovality : 1%
  - h) E.P Angle : + 5° / - 2.5°
  - i) Diagonal diff : 3 mm

### 4.3 **WELDING**

#### 4.3.1 **WELDING CONSUMABLES**

- 4.3.1.1 Welding consumables conforming to the qualified welding procedures shall be used. However the following guide lines are provided.

- 4.3.1.2 Unless specified otherwise in the WPS, basic coated electrodes E7018 shall be used for SMAW of all structural components involving materials of IS2062 E250 grade.
- 4.3.1.3 **All the electrodes are to be procured using Welding consumable procurement instruction (WCPI) issued by WTC.**
- 4.3.1.4 For duct welds, rutile electrodes (E6013) shall be used.
- 4.3.1.5 All low hydrogen electrodes shall be dried in the baking oven at 250-300 deg.C for 2 hours and the electrodes shall be held at 100-150 °C until they are used. Electrodes shall not be re-baked more than once and use of electrodes in wet condition is prohibited.
- 4.3.1.6 All rutile electrodes (EXX 13) shall be dried at 100-150 °C deg. C for 1 hour min. and held at 100-150 °C deg.C till use.
- 4.3.1.7 Fluxes for SAW shall be dried at 250 °C for 1 hour min. before use. Height of flux bed while drying in pan or oven, shall not be more than 100mm.
- 4.3.1.8 Unless otherwise specified, SS consumable shall be baked as per Electrode manufacturer's recommendations and stored at 100 ° - 150 ° C until use.
- 4.3.1.9 The type of welds employed in the structural fabrications (Girders, Columns, Beams & Base plates etc) are identified in the annexure –A along with sketch for better clarity and under standing. For further details the fabricator can ref the engg.drg. no.3-35-110-00995/00

#### 4.3.2 FIT UP

- 4.3.2.1 Proper fit up shall be ensured before welding as per Drawing. Tack welding or mechanical clampings shall be used to maintain the fit up requirements before and during welding. Bridge pieces used during fit up shall be of ferritic for ferritic materials and stainless for stainless steel materials. However for P15E Gr.1.(F91 & F92) prepare a fixture for fit-up of butt joint of „U“ rod with Straight rods
- 4.3.2.2 Dimensions of the cross sections of groove welded joint shall be within the following tolerances w.r.t . drawing requirements:

	Root not back gouged	Root back gouged
1. Root face of joint(land)	± 2 mm	Not limited
2. Root opening of joint (with out backing)	± 2 mm	+ 2 mm - 3 mm
Root opening of joint* with backing)	+ 6 mm - 2 mm	Not Applicable
3. Groove angle of of joint	+ 10° - 5°	+ 10° - 5°

\*(NOTE): Root opening wider than permitted by above tolerances but not greater than twice the thickness of the thinner part or **20mm**, whichever is less may be corrected by edge buildup to acceptable dimensions prior to welding. Such buildup edge shall be MPI / LPI checked. **For SAW process, the maximum root opening variation (minimum to maximum opening as fit-up) may not exceed 3 mm.**

- 4.3.2.3 For C. S. fillet welds, the parts shall be as close as practicable and gap shall be limited to 5 mm (If gap exceeds 2 mm, the leg of fillet shall be increased by the amount of gap but in no case shall exceed 4.8 mm). For thickness 75 mm and above gap up to 8 mm can be permitted provided suitable backing is used.
- 4.3.2.4 For S. S. fillet welds, the parts shall be as close as practicable. Gaps 2 mm and above upto 5mm are acceptable if the fillet size is increased by an amount equal to the gap.
- 4.3.2.4 Parts to be joined by butt welds shall be properly aligned. An offset not exceeding 10% of the thickness of the thinner part joined can be permitted, but in no case more than 3 mm, is permitted.
- 4.3.2.5 The types of weld joints indicated in the fabrication of structural components are identified with symbols in ANNEXUR -A & B .For further details refer the Engg standard drawing no.3-35-110-00995 (Latest)

### 4.3.3 PRE HEATING

- 4.3.3.1 Pre heating requirements for welding shall be as per Clause 4.6.7 and controls shall be exercised as detailed below. No preheating is required for stainless steels.
- 4.3.3.2 Preheating shall be maintained during the entire process of welding.
- 4.3.3.3 Preheating is to be done using gas burner or induction / resistance heating. The temperature must be uniform and verified using thermal chinks or thermocouples prior to start of welding as well as during welding for a width of 1.5 times the base metal thickness or 75 mm whichever is more, around the point of welding (not less than 25mm in case of tack welding in all directions).
- 4.3.3.4 Where interpass temperature control is required during welding, the temperature must be ensured using thermal chinks / thermocouples with recorder . Inter pass nitrogen / air cooling can be adopted to maintain inter pass temperature in case of stainless steels.
- 4.3.3.5 Wherever post heating is specified after welding, the preheating shall be continued till attaining the post heat temperature and maintained for the required time and cooled slowly by wrapping suitable insulating blankets like asbestos.
- 4.3.4 Welding shall be performed using qualified procedures and qualified personnel. Edge preparation and welding details shall be as per drawing.
- 4.3.5 For items to be manufactured at subcontractor's works (including away centre fabrication) , for requirements of procedure and personnel qualification SIP:NP: 07 (Latest) shall be followed.
- 4.3.6 When double bevel welding is adopted, back gouging and grinding is to be done. Back gouged groove shall be checked with PT / MT before welding from second side. However for P15E Gr.1.(F91 & F92) Only back grinding to be done after interstage PWHT.
- 4.3.7 Proper sequence of welding shall be adopted to minimise distortion. The distortion of the finished jobs, if any may be corrected by mechanical means / hot correction.

- 4.3.7.1 For welding of SS extreme care is to be taken in weld sequencing to minimize the weld distortion and shrinkage. For complex weldments a weld sequence instructions may be prepared by contractor prior to work commencement. Weld joints likely to have high shrinkage should be welded (with minimum restraints) before welding other joints providing allowance for shrinkage. For further details ref. SQP:NP:20
- 4.3.7.2 While cutting long web plates suitable camber may be provided /required to compensate for the distortion during cutting and welding.
- 4.3.8 All butt welds of divider plate and guide vanes in ducts shall be flush ground inside.
- 4.3.9 The use of jigs and fixtures is recommended where ever practicable. Suitable allowances shall be provided for weld shrinkage. Proper sequence of welding shall be followed to control the distortion during welding.
- 4.3.10 All temporary attachments shall be welded with the required preheat. After their removal welded spots shall be ground flush and LPI checked.
- 4.3.11 Groove welds shall preferably be made with minimum reinforcement unless and otherwise specified in drawing / SQP. In case of butt welds, reinforcement shall not exceed 3.2 mm. and shall have gradual transition to the plane of the base material surface.
- 4.3.12 The surface of the welds shall be free from coarse ripples, overlaps, undercuts and abrupt ridges to avoid stress raisers.
- 4.3.13 Where parts of different thicknesses are welded or surface offset is more, the transition shall be made gradual by grinding / machining with **1: 2.5 taper unless specified in the drawing.**
- 4.3.14 Stray arcs shall be avoided to the extent possible. Arc spots if noticed shall be ground and checked by LPI / MPI. Thickness requirements shall be ensured after grinding.
- 4.3.15 Pre heating of Gr 91 & Gr 92 shall be 220 °C. For other process parameters refer the applicable WPS

#### **4.4 WELD REPAIRS**

- 4.4.1 Removal of defective weld / portions of the base material may be done by machining, grinding, chipping, gas cutting, oxygen gouging or carbon arc gouging. Defective portions of the weld shall be removed without substantial removal of sound base metal.
- 4.4.2 For under sized welds additional weld metal shall be deposited using an electrode preferably smaller than that used for making original weld limited to 4mm in diameter. The surfaces shall be cleaned thoroughly before deposition.
- 4.4.3 Defective welds/base metal shall be repaired by removing or/and rewelding as follows:
- 4.4.3.1 Overlap / excess weld metal shall be removed by grinding.
- 4.4.3.2 For excess concavity, crater, undersize & undercuts, deposit additional weld metal after cleaning the weld surface.
- 4.4.3.3 For Cracks in weld or base metal, ascertain the extent of crack by suitable NDE /acid etching, remove the crack to sound metal upto each end of the crack by arresting the ends for further propagation and reweld.

4.4.3.4 For weld porosity, slag inclusions & lack of fusion remove defective portions & reweld.

#### **4.5 HOT CORRECTION**

4.5.1 Members which require hot correction are to be supported at suitable locations and mark the locations for heating.

4.5.2 Heat the locations marked by using neutral flame. Torches used for heating shall be moved continuously & uniformly over selected area to avoid localised over heating.

4.5.3 For Carbon steels the maximum temperature shall not exceed 650 ° C and shall be ensured using thermal chinks / thermocouples.

The temperatures for alloy steels shall not cross for P3 -649 ° C, P4 – 704° C , P5 – 732° C during hot corrections.

4.5.3.1 For Austenitic stainless steels the maximum temperature shall not exceed 430 ° C and shall be made known to inspection authorities . Otherwise , after hot correction solution annealing at 1050 – 1100 deg C is to be done.

4.5.3.2 For Ferritic/Martensitic/Duplex stainless steels the maximum temperature shall not exceed 315° C and shall be made known to inspection authorities . The temperature shall be ensured using thermal chinks / thermocouples.

4.5.4 Additional dead weights may be placed over the positive side of the bend depending upon the requirement to accelerate hot correction.

4.5.5 Allow for natural cooling. Accelerated cooling shall not be adopted. Remove the dead weights used after cooling.

4.5.6 Wherever the correction for distortion affects the weld joints, applicable NDE shall be repeated after the correction.

#### **4.6 POST WELD HEAT TREATMENT (PWHT)**

4.6.1 The process controls ( temperature control and recording) for heat treatment shall cover the activities before, during and after heat treatment.

4.6.2 The weldment shall be cleaned to free of grease, oil etc. prior to heat treatment.

4.6.3 PWHT shall be done in a furnace or by local heating a band ( including the entire weld and adjacent area of the base metal) .

4.6.4 The thermocouples and recording instruments shall be calibrated as per applicable standards and records maintained. The furnace shall have been qualified and calibrated.

4.6.5 All materials to be heat treated in furnace shall be loaded in such a way that they shall not be subjected to direct flame impingement. Jobs shall be preferably loaded on raised plat forms so that no material projects into the plane of burners. Alternatively flame deflectors may be provided in front of the burners to avoid direct flame impingement. Ensure loading of test coupons wherever applicable. The furnace temperature shall not exceed 315 ° C at the time of loading material / weldment.

4.6.6 Number of thermocouples and their location shall be decided covering maximum and minimum thickness and covering all the zones. The temperature variation within 5 meters shall not exceed 140 ° C during heating period ( above 315 ° C).

4.6.7 The **temperature requirements** for Pre heating, Post Weld Heat Treatment(PWHT) & temperatures **for welding** are given as below.( Unless otherwise specified in WPS.)

Material	Pre heating	PWHT	Remarks
<b>Butt/groove welds:</b>			
P1	For t> 38mm , 150 ° C	For t> 50 mm, 600-650 ° C	
P3	All thickness, 150 ° C	All welds when t >16 mm, 620-650 ° C.	For all butt welds in tension members, PWHT to be done.
P4	All thickness, 150 ° C	All welds when t >16 mm, 650-680 ° C.	For all butt welds in tension members, PWHT to be done.
P5	150 ° C (Note2)	680-710 ° C	All welds
P8	120 ° C, 300 type 205 ° C, 400 type	- -	
<b>Fillet welds :</b>			
P1	For t> 38mm , 150 ° C	-	
P3	All thickness, 150 ° C	if throat thickness>13mm, 620-650 ° C.	
P4	All thickness, 150 ° C	if throat thickness>13mm, 650-680 ° C.	
P5	150 ° C (Note2)	All thickness, 680-710 ° C	
P8	120 ° C,300 type 205 ° C ,400 type	-	

Note 1 All welds on P5 material shall be post heated at 250 ° C for 2 hrs or 150 ° C for 4 Hrs, immediately following welding.

4.6.7.1 The soaking time shall be as follows:

- For P1 materials the soaking time shall be 1 hr/inch of thickness(t) (2.5 mts / mm) upto 2" and 2 hrs + 15 minutes for each additional inch for t > 2".
- For P3, P4 & P5 materials the soaking time shall be 1 hr/inch of thickness (2.5 mts/ mm) upto 5" and 5 hrs + 15 minutes for each additional inch for t > 5".
- For combination cycles mentioned above, calculate the minimum soaking time for individual components as 2.5 minutes/mm of the thickness of weld/material whichever is applicable. Soaking time selected for the cycle shall not exceed the limits given below:

Material	Thickness (mm)	Max. soaking time (minutes)
P1 (A,B,C), P4,P5A,	Up to 25 mm	125
P1 (A,B) + P4	26 - 50 mm	200
P1C + P4, P1 + P3	51 - 80 mm	250
P4 + P5A	81 - 150mm	375
P15E Gr1		

4.6.7.2 Unless otherwise specified, in case of mixed loads of materials not covered under simulation HT, the following heat treatment temperatures shall be followed. In such cases, guidelines for soaking can be taken from Clause 4.6.9.

For components having butt joint between P1 & P4, or P3 & P4, the cycle shall be 630 – 670°C.

Where a component has a butt joint between P4 & P5A, the cycle shall be 680 - 720° C.

Where a component has a butt joint between P1 & P3, the cycle shall be 620-660 °C

For P1+P5A material combination, follow the WPS requirements

The following jobs shall not be combined in the same cycle during PWHT.

i. separate jobs of P1 and P4 ii. separate jobs of P4 and P5.

4.6.8 The following rules shall apply to establish the thickness to be used in determining the soaking time for PWHT.

4.6.8.1 For Butt welds, the thickness shall be **weld metal thickness**. For bar stock, the thickness shall be the diameter. **The holding time is based on the weld metal thickness even though some material in the weldment is thicker than the weld.**

4.6.8.2 For fillet welds, the thickness shall be the throat thickness. **The effective throat of a combination PJP bevel groove weld and a fillet weld shall be the shortest distance from the joint root to the weld face of the diagrammatic weld minus 1/8 in [3 mm] for any groove detail requiring such deduction as shown in Fig-1**

4.6.8.3 For partial penetration branch welds, the thickness shall be the depth of the groove prior to welding.

4.6.8.4 For repairs, thickness shall be the depth of the groove as prepared for repair welding.

4.6.8.5 For combination of different welds in a component, maximum thickness of weld shall govern.

4.6.9 Requirements of Rate of Heating (ROH) above loading temperature 315 °C and Rate of Cooling (ROC) are as given below. During heating and cooling, variation in temperature between thermocouples shall be 85 °C maximum, unless otherwise specified.

Thickness	ROH / ROC (Max) Above / upto 315 °C
Up to 25mm	220 °C / hour
26 - 50 mm	110 °C / hour
50 – 75 mm	75° C / hour
Above 75 mm	55 °C
For S.S Matl	200 °C / hour min (Forced air cooling)

- 4.6.10 In case of interruption during Heat treatment the following action has to be taken depending on the stage of occurrence:

Type of Heat treatment	Stage of interruption	Action
Annealing & stress relieving	Heating	Heat treat subsequently as specified
	Soaking	Heat treat subsequently for balance soaking <b>with minimum 15 minutes.</b>
	Cooling	If the ROC during interruption period meets the specified rate, cool subsequently at required rate upto 400° C. Otherwise, reheat to the soaking temperature, hold for 15 minutes and then cool at the specified rate
Normalising(N) Tempering (T) & Soln. annealing (S)	Heating	Heat treat subsequently as specified
	Soaking	Heat treat subsequently for full soaking(N,S) / Balance soaking (T)
	Cooling	Not applicable

- 4.6.11 Local heat treatment can be carried out by Resistance heating or Induction heating. For local heat treatment of weld joints, width of the heated band on either side of the weld must be **at least 3 times the width of the widest part of the weld groove but not less than twice the thickness of the thicker part welded.**
- 4.6.11.1 **The width of the insulation band on either side shall be at least twice the width of the heating band.**
- 4.6.11.2 A minimum of three thermocouples shall be placed such that at least one is on the weldment /HAZ and the other two on the base material on either side of the weldment.
- 4.6.11.3 The winding arrangement shall be established to attain the required temperature. The initial rate of heating shall be minimum such that it stabilises at the required rate of heating before reaching 400 deg C.
- 4.6.12 After heat treatment, the charts shall be correlated with the job and cleared by QC. The chart shall contain cycle no, Date, W.O and DU details. Temperature, ROH, ROC and soaking time shall be calculated, entered in the chart and signed off by QC.
- 4.6.13 Wherever applicable the test coupons shall be tested and reports obtained to complete the clearance of heat treatment operation.

## 5.0 NON-DESTRUCTIVE TESTING

- 5.1 The requirement of NDE, extent and type of examination shall be as per respective product SQP and / or CQP .Wherever product SQP is not existing the following requirements shall apply.
- 5.2 Visual inspection shall be performed as per SIP:NP:06 latest
- 5.3 RADIOGRAPHY.
- All Butt welds of Carbon steel for thickness  $t > 32\text{mm}$
  - All butt welds of alloy steels for thickness  $t > 12\text{mm}$  for P5 and  $t > 16\text{mm}$  for P4&P3.
  - All butt welds in monorails.
  - SS butt welds of  $t > 16\text{mm}$  unless otherwise specified.

- 5.3.1 All radiographic films shall possess Firm code, RT agency, Cust. No, Part No, RT reference Number. and weld location reference number. The job shall be numbered with Radiograph number.
- 5.4 MPI / LPI BEFORE PWHT
- All flame cut edges of Carbon steel for  $t \geq 38$  mm and alloy steels for  $t > 12$ mm.
  - All butt welds joining plate members in which one of the plate member is over 25 mm thick for Carbon steel and over 12 mm thick for alloy steel.
  - All fillet welds between tension flange and web.
  - All fillet welds joining plate members in which both the plate members are over 25 mm thick for Carbon steel and over 12 mm thick for alloy steel.
  - For all butt welds of CS & AS weld groove after back chipping prior to welding from second side.
  - All main fillet welds for SS require LPI
  - MPI/LPI for all fillet welds & HAZ of SA387 Gr.22 materials after HT.
- 5.5 All NDE shall be carried out by qualified personnel as per BHEL NDT procedures. Where subcontractors use their own procedures for NDE the same shall have the approval of BHEL NDTL.

## **6.0 MACHINING**

### **6.1 GENERAL**

- 6.1.1 Ensure of raw material identification throughout the machining process. Traceability to the contract shall be ensured by stamping or marking / painting or by tags( WO No.and DU / Part no.)
- 6.1.2 Where the material identification is likely to be removed during cutting or machining , the transfer of material identification shall be ensured.
- 6.1.3 In case of components / part processed items received from Subcontracting / other shops, ensure the completeness and clearance by QC / Customer Inspector through Inspection Reports / OPS.
- 6.1.4 Proper care shall be taken during handling of materials at all stages of manufacture. Items stored in the shop floor shall be properly identified and preserved to prevent mixup and damages / rusting / warpages.
- 6.1.5 All Machined surfaces shall be properly protected and stored. Wherever long storage is envisaged, they shall be preserved with grease / rust preventive oils and protected suitably with polythene / gunny bag or plastic peel off coatings.

### **6.2 MARKING**

- 6.2.1 The marking on machined components shall be in such a location which will not be detrimental to the surface finish requirements of the component.
- 6.2.2 Purpose of marking is to:
1. Ensure availability of machining allowance.
  2. Identify locations for machining.
  3. Provide reference for setting and inspection.

### 6.3 PROCESS CONTROLS

- 6.3.1 The following shall be ensured for selection of work centers, tools, jigs and fixtures:
- The work centre for machining shall be identified in OPS / loading sheet based on the process capability of the machine or Machine accuracy established to suit the tolerances.
  - Test hardware (Jigs, Fixtures and Templates) used as a means of inspection / process control shall have been qualified through first off trials and shall be regulated through valid number. The same shall be reflected in the OPS / loading sheet .
  - Softwares used in case of CNC / NC machines shall have been validated through trials or inspection of similar components produced and accepted.
  - All cutting tools shall have been ensured for its correctness before use. In case of regrinding of tools they shall be verified after regrinding.
- 6.3.2 The following shall be ensured before setting the job on the machine, during processing and after completion of machining:
- Ensure the verticality and flatness of the job after clamping by using the reference markings or dialing the surfaces. Ensure the adequacy of clamping.
  - Ensure proper clamping of the correct tool in to the tool holders.
  - After machining the machined surfaces shall be cleaned and all corners shall be deburred. After removing from the machine they shall be properly stored.
  - Before starting reaming ensure proper material allowance for finish operation.
  - During drilling, reaming and tapping the removal of chips shall be done periodically to prevent clogging of chips. For deep drilling ensure that run out and drill travel are verified in free condition and ensure proper clamping of the tools.

### 6.4 INSPECTION

- 6.4.1 Ensure completeness of all final machining operations. Dimensional inspection shall be done with relevant drawings. Ensure use of calibrated instruments / gauges.
- 6.4.2 Unless otherwise specified in the drawing or SQP, the following tolerances can be used for untoleranced dimensions.

#### 1. Linear Tolerance (:millimeters) - Medium

PERMISSIBLE DEVIATIONS FOR BASIC SIZE RANGE						
Up to 6	From 6 TO 30	from 30-120	From 120-400	From 400-1000	From 1000-2000	Above 2000
± 0.1	± 0.2	± 0.3	± 0.5	± 0.8	± 1.2	± 2.0

#### 2. Angular Tolerance

- Assembly characteristics ± 0.5°
- Other characteristics ± 1°

## 7.0 FINAL INSPECTION

7.1 All dimension shall be inspected as per relevant drawings. Tolerances for fabricated items when not specified in drawings shall be as per clause 4.0.

## 8.0 CLEANING AND PAINTING

8.1 All the temporary cleats, bridge pieces shall be removed carefully so as to avoid damage to parent material. Temporary tack welds shall be ground smooth. Complete assembly shall be cleaned to remove mill scales, spatter, slag, rust, oil or grease. Surfaces shall be prepared and painted as per SIP:PP:22 (latest). Site EPs shall be applied with weldable primer. All site EP shall be protected suitably from mechanical damage. **The machined/bolted surfaces shall be applied with rust preventive oil coating and painting shall not be done on these surfaces. All the machined and bolted surfaces should be suitably masked to avoid handling damages.**

8.2 All temporary stiffeners / attachments used for transportation and handling that are removed after site assembly shall be painted with yellow paint.

8.3 Match marking and flow direction for applicable components shall be as per the respective product SQP./Drawing

8.4 The following details shall be clearly marked with relevant details by paint, bordered and covered by one coat of transparent varnish

Project Name :  
 Work order number :  
 Component / Assly. Designation :  
 DU Number :  
 Weight :  
 Sub-contractor Name / Code :

8.5 Tension flanges in girders are to be identified by hard punching indicating 'TENSION FLANGE'.

8.6 Apply grease on the threaded portion of "U" rod and protect the threaded portion from damage with suitable plastic end caps.

8.7 For subcontracted items the firm code shall be punched and bordered with white paint.

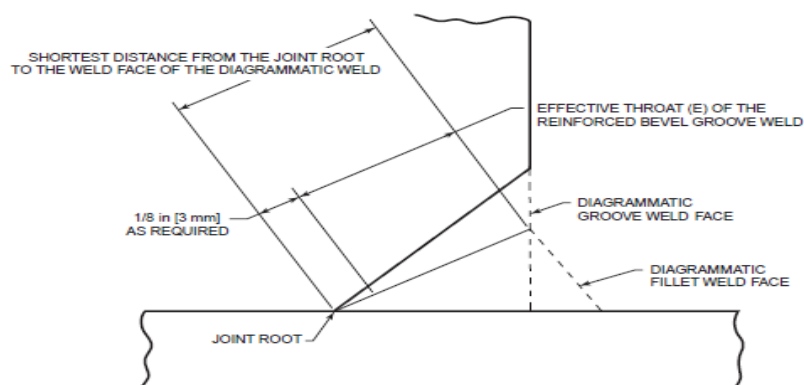
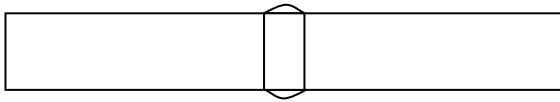

Fig-1

ANNEXURE - A

**SQUARE BUTT WLED**



**BEVEL WELD**

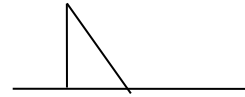

**K WELD**

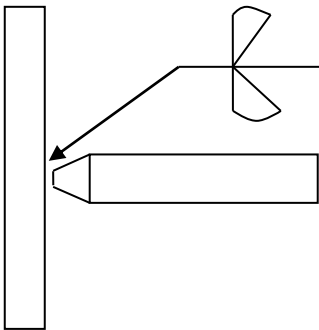

**FILLET WLED**

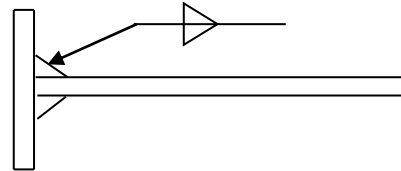

**SINGLE V JOINT**

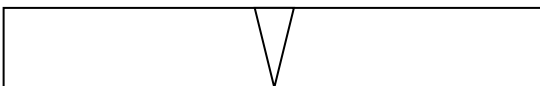

**DOUBLE V JOINT**

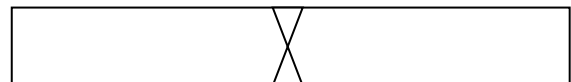

## ANNEXURE-B

Examples illustrated with sketch for P1 materials.

**Sketch-1 (Full penetration weld joint)**

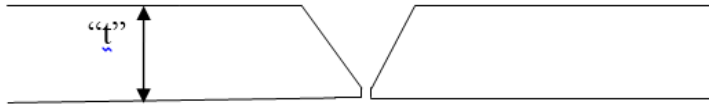

Where "t" is base metal thickness. If "t" is > 50mm PWHT to be done. RT is applicable and to be carried out as per Cl 5.3 and CQP.

**Sketch:2 (Full penetration weld joint double V )**



If " $t_1/t_2$ " > 50mm, PWHT to be done. RT is applicable and to be carried out as per Cl 5.3 and CQP.

**Sketch:3 (Partial penetration weld joint bevel)**

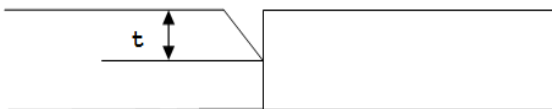

Where "t" is weld metal thickness. If weld depth is > 50mm PWHT to be done, RT is not applicable, MPI to be done.

**Sketch:4 (Partial penetration weld joint)**



PWHT & RT is not applicable in this case, since only seal welding is required and the weld thickness does not exceed 50 mm. MPI to be done.

**Sketch:5 (Partial penetration weld joint double V)**

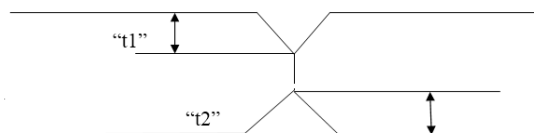

Where "t" is equal to  $t_1+t_2$ . If "t" is > 50mm PWHT to be done. RT is not applicable. MPI to be done

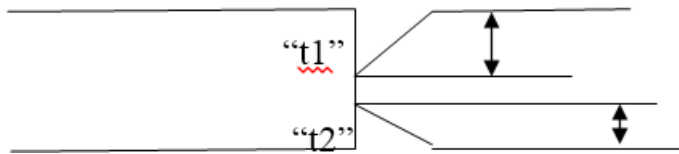
**Sketch:6 ( K connection Partial penetration weld joint)**

Where "t" is equal to  $t_1+t_2$ . If "t" is  $> 50\text{mm}$  PWHT to be carried out. RT is not applicable. MPI to be done.

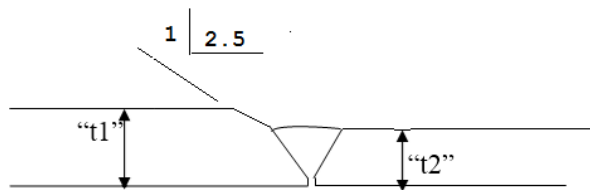
**Sketch: 7 (Bi thickness joint)**

If  $t_2$  is  $>50\text{mm}$  PWHT to be carried out and if  $t_2 > 32\text{mm}$  RT is to be carried out as per Cl 5.3 and CQP. Chamfering in  $t_1$  shall be taken with taper 1:2.5 (Unless specified in drawing)