



Bharat Heavy Electricals Limited
Industrial Valves Plant
Goindwal Sahib (Punjab)

Enquiry No.
2324-028E

Date:
10.07.2023

NOTICE INVITING TENDER (NIT)

Dear Sir / Madam,

BHEL Goindwal Sahib (Punjab) invites offers from interested bidders / suppliers for submission of their offer through e-procurement mode at <https://eprocurebhel.co.in/>. Offers in any other mode will not be accepted. In case of any difficulty faced while registering on BHEL's e-Procurement portal developed by NIC, queries may be addressed to 0120-4001002, 0120-4001005 and 0120-6277787; email: support-eproc@nic.in. These details are also available on 'Contact Us' page of the portal.

Tender enquiry no. & date	2324-028E dated 10.07.2023
Form of contract	Supply
Tender / Item description	Fasteners GVFST
Material standard / Drawings	As per attached TDC(s), Drawings and BPS.
Location(s) of Supply / Work	BHEL, IVP Goindwal, Punjab – 143422, India.
Earnest Money Deposit (EMD)	Not Applicable
Quotation parts	Two Part Bid
Tender download / Bid submission start date	10.07.2023 (17:00 Hrs. IST)
Tender download / Bid submission end date	21.07.2023 (12:00 Hrs. IST)
Tender / Bid opening date	21.07.2023 (15:30 Hrs. IST)
Validity of offer (In days)	70 days from techno commercial bid opening (Part I)
Quantity variation	+/- 10% of tender quantity
Delivery schedule	Within 90 days from the date of PO placement / LOI
Tender evaluation	Item Wise as detailed in Special Terms and Conditions
Reverse auction	Not Applicable
Make In India (MII) Purchase Preference	Applicable
MSE reserved	Items are reserved for MSE Manufactures
Contact person details	Sumeet Bansal, Sr. Manager 01859-224 628, sbansal@bhel.in Pranshu, Dy. Manager 01859-224 685, pranshu@bhel.in

PART-I (TECHNO-COMMERCIAL BID)

(To be filled by bidder & submit with offer as pdf file only)

Tender Enquiry No. & Date**2324-028E dated 10.07.2023****Tender Description****Supply of Fasteners GVFST**

Bidder must note following points:

1. This workbook is protected, except for cells where comments / confirmation is to be given by bidder.
2. Bidder is advised not to unprotect / tamper the sheet / alter the terms mentioned in the sheet.
3. Any alteration to terms mentioned by BHEL will be considered as tampering and bidder's offer shall be liable for rejection.
4. **Bidders are advised to only fill the unprotected cells (shaded cells) by dropdown or writing the comments as applicable as their confirmation. Bidders are advised to submit duly filled & signed 'PDF' file as techno-commercial (Part-I) bid'. Failure on the part of bidder in not returning this duly filled-up techno-commercial bid and / or submitting incomplete replies may lead to rejection of bidder's quotation.**
5. All the commercial terms and conditions shall be indicated by vendor in this format only and nowhere else in his quotation. However, in case the space for vendor's reply is not sufficient against a particular question, the vendor shall furnish same by way of separate annexure / sheet attached to this questionnaire, indicating cross-reference of respective clauses.

BIDDER'S DETAILS

Sr. No.	Elements	Remarks
1	Bidder's Name/Name of the Firm	
2	Quotation reference no. & date	
3	Contact Person Name/Number/Designation	Name: Contact No: Designation:
4	Email ID (s)-(Can be provided more than one)	
5	Mobile No. (s)	
6	Tel. No. (s)	
7	Fax No.	
8	Registered Address	
9	Address for Correspondence	
10	Bidder Type (Indian / Foreign):	
11	Company's Establishment Year	
12	Company's Nature of Business (Tick the relevant option <input type="checkbox"/>)	<input type="checkbox"/> Manufacturer <input type="checkbox"/> Dealer/ Trader/ Stockist/Channel Partner/Agent/etc.
13	Company Category (Micro unit as per MSME / Small unit as per MSME /	
14	Status of the Company / Firm * (Relevant documents must be enclosed) (Tick the relevant option <input type="checkbox"/>)	<input type="checkbox"/> Public Limited; <input type="checkbox"/> Private Limited <input type="checkbox"/> Partnership Firm; <input type="checkbox"/> Single Ownership
15	Name of Owner / Partner's of Firm	
16	GST No.	

TECHNICAL CONDITION DETAIL

Sr. No.	Elements	Response	Remarks
1	Technical : Supply of Fasteners GVFST as per tender documents (if selected 'Accepted with deviation', please mention the deviation clearly)	Select from the drop down list	

COMMERCIAL CONDITIONS & DETAILS

Sr. No.	Elements	Response	Remarks (if any)
1	IGST supply (%)	Select from drop down list	
2	SGST supply (%)	Select from drop down list	
3	CGST supply (%)	Select from drop down list	
4	Validity: 70 days from techno commercial bid opening. (refer tender terms & conditions)	Select from the drop down list	
5	Delivery period: Within 90 days from placement of PO / LOL. (refer tender terms & conditions)	Select from the drop down list	
6	Please attach Declaration for proof as a manufacturer (Refer special terms S2.1)	Select from drop down list	
7	Documents regarding Purchase Order/s of 'Fasteners' from any customer with minimum cumulative value of Rs. 4,00,000 along with the proof of execution (Refer special terms S2.2)	Select from the drop down list	
	Details of Submitted PO and their Proof of Execution has been filled in Annexure -P , as per above stated PQC term at Sr. no. S2.2.)	Select from drop down list	
8	Conflict of Interest among Bidders / Agents (Refer clause no. 7 of General Contract conditions (GCC))	Not having Conflict of Interest with other Bidders	
9	LD clause: Penalty for late delivery will be applicable @ 0.5% per week or part thereof subject to a maximum of 10.0 %. (Refer Clause 11 of General Contract Conditions (GCC)).	Select from the drop down list	

PART-I (TECHNO-COMMERCIAL BID)

(To be filled by bidder & submit with offer as pdf file only)

Tender Enquiry No. & Date

2324-028E dated 10.07.2023

Tender Description

Supply of Fasteners GVFST

Bidder must note following points:

1. This workbook is protected, except for cells where comments / confirmation is to be given by bidder.
2. Bidder is advised not to unprotect / tamper the sheet / alter the terms mentioned in the sheet.
3. Any alteration to terms mentioned by BHEL will be considered as tampering and bidder's offer shall be liable for rejection.
4. **Bidders are advised to only fill the unprotected cells (shaded cells) by dropdown or writing the comments as applicable as their confirmation. Bidders are advised to submit duly filled & signed 'PDF' file as techno-commercial (Part-I) bid'. Failure on the part of bidder in not returning this duly filled-up techno-commercial bid and / or submitting incomplete replies may lead to rejection of bidder's quotation.**
5. All the commercial terms and conditions shall be indicated by vendor in this format only and nowhere else in his quotation. However, in case the space for vendor's reply is not sufficient against a particular question, the vendor shall furnish same by way of separate annexure / sheet attached to this questionnaire, indicating cross-reference of respective clauses.

10	Payment term: (Refer clause no. 13 of General Contract conditions (GCC))	Select from the drop down list	
11	Warranty Period: Supplier shall give a warrantee for a period of 18 months from the date of receipt. In case of non-acceptance of this term bid will be rejected. (Refer clause no. 18 of GCC)	Select from the drop down list	
12	Risk purchase: If the supplier fails to deliver the goods within the delivery specified in the Purchase Order, BHEL will be entitled to terminate the contract and to Purchase elsewhere at the risk and cost of the seller either the whole of the goods or any part which the supplier has failed to deliver or despatch within the delivery period mentioned in the Purchase Order. (Refer Cl. 21 of GCC in Tender Terms & Conditions)	Select from the drop down list	
13	Please attach valid MSE certificate latest MSME Guidelines (Refer clause no. 25 of GCC)	Select from drop down list	
14	Make in India (MII) (Refer clause no. 26 of GCC)	Local Content Declaration	Select from drop down list
		Details of location at which local value addition will be made is as follows:	Select from drop down list
15	In line with clause no. 27 of GCC : This bidder certifying that, "I have read the clause regarding restrictions on procurement from a bidder of a country which shares a land border with India; I certify that this bidder is not from such a country or, if from such a country, has been registered with the Competent Authority. I hereby certify that this bidder fulfils all requirements in this regard and is eligible to be considered."	Select from drop down list	
16	Firm Price: The quoted / finalised rates shall be firm till execution of the supplies.	Select from the drop down list	
17	I have thoroughly gone through the attached tender terms & conditions and understood the above techno-commercial requirements	Select from drop down list	

Item details

Item Sl. no.	Material Code	Description	Qty in no	Quoted / not quoted
1	964562620000	BOLT-5/8"x70 -B7-N001	1,000	
2	964562800000	NUT -5/8" -2H-N025	1,000	
3	964655080000	FT STUD-M33x3.5x220 -B7-0025	200	
4	964652740000	NUT -M33x3.5 -2H-3234-H33	400	
5	964656370000	FT STUD-5/8"-11UNC-2A-105-B8M	1,000	
6	964656490000	HEX NUT-5/8"-11UNC-2B-GR.8M	2,000	
7	964656380000	FT STUD-5/8"-11UNC-2A-118-B8M	1,000	
8	964656490000 (Same as Sr. No. 6)	HEX NUT-5/8"-11UNC-2B-GR.8M	2,000	
9	964656390000	FT STUD-3/4"-10UNC-2A-120-B8M	1,000	
10	964656500000	HEX NUT-3/4"-10UNC-2B-GR.8M	2,000	
11	964656430000	FT STUD-1"-8UNC-2A-158-B8M	200	
12	964656520000	HEX NUT-1"-8UNC-2B-GR.8M	400	
13	930608660000	STUD-1076 M10X55	500	
14	413200001000	NUT -M10 -CL8-IS1364P3	500	
15	412370807500	BOLT-M 8x75 -8.8-IS1364-P1	1,500	
16	413200091600	NUT -M16 -CL8-IS1364P3-GALV	2,000	
17	413190001200	NUT -M12 -2H BPS 41319	1,000	
18	413200001000 (Same as Sr. No. 14)	NUT -M10 -CL8-IS1364P3	5,000	
19	413190001000	NUT -M10 -2H	2,000	

PART-I (TECHNO-COMMERCIAL BID)

(To be filled by bidder & submit with offer as pdf file only)

Tender Enquiry No. & Date

2324-028E dated 10.07.2023

Tender Description

Supply of Fasteners GVFST

Bidder must note following points:

1. This workbook is protected, except for cells where comments / confirmation is to be given by bidder.
2. Bidder is advised not to unprotect / tamper the sheet / alter the terms mentioned in the sheet.
3. Any alteration to terms mentioned by BHEL will be considered as tampering and bidder's offer shall be liable for rejection.
4. **Bidders are advised to only fill the unprotected cells (shaded cells) by dropdown or writing the comments as applicable as their confirmation. Bidders are advised to submit duly filled & signed 'PDF' file as techno-commercial (Part-I) bid'. Failure on the part of bidder in not returning this duly filled-up techno-commercial bid and / or submitting incomplete replies may lead to rejection of bidder's quotation.**
5. All the commercial terms and conditions shall be indicated by vendor in this format only and nowhere else in his quotation. However, in case the space for vendor's reply is not sufficient against a particular question, the vendor shall furnish same by way of separate annexure / sheet attached to this questionnaire, indicating cross-reference of respective clauses.

We further, confirm that we have quoted the rates in the tender considering Inter-alia the

1. Tender Document(s)
2. Additional Document(s) (if any)
3. BOQ Document (Price Bid Format-Part-II)
4. Corrigendum (if any)
5. Pre Bid Meeting Minutes (if any)

We hereby certify that we have fully read and thoroughly understood the tender requirements and accept all terms and conditions of the tender including all corrigendum/addendum issued (if any). Our offer is in confirmation to all the terms and conditions of the tender including all corrigendum/addendum (if any) and minutes of the pre-bid meeting (if any). In the event our offer is found acceptable and Order is placed /Contract is awarded to us, the complete tender document shall be considered for constitution of Order / Contract Agreement.

Validate

Print

Help

Item Wise BoQ

Tender Inviting Authority: BHEL Goindwal Sahib (Punjab)

Name of Work: Supply of Fasteners GVFST

Contract No: 2324-028E dated 10.07.2023

Name of the Bidder/ Bidding Firm / Company :	
--	--

PRICE SCHEDULE

(This BOQ template must not be modified/replaced by the bidder and the same should be uploaded after filling the relevant columns, else the bidder is liable to be rejected for this tender. Bidders are allowed to enter the Bidder Name and Values only)

NUMBER #	TEXT #	TEXT #	NUMBER #	TEXT #	NUMBER #	NUMBER #	TEXT #
Sl. No.	Item Description	Item Code / Make	Quantity	Units	BASIC RATE In Figures To be entered by the Bidder Rs. P	TOTAL AMOUNT Without Taxes	TOTAL AMOUNT In Words
1	2	3	4	5	13	53	55
1	BOLT-5/8"x70 -B7-N001	964562620000	1000	Nos		0.0000	INR Zero Only
2	NUT -5/8" -2H-N025	964562800000	1000	Nos		0.0000	INR Zero Only
3	FT STUD-M33x3.5x220 -B7-0025	964655080000	200	Nos		0.0000	INR Zero Only
4	NUT -M33x3.5 -2H-3234-H33	964652740000	400	Nos		0.0000	INR Zero Only
5	FT STUD-5/8"-11UNC-2A-105-B8M	964656370000	1000	Nos		0.0000	INR Zero Only
6	HEX NUT-5/8"-11UNC-2B-GR.8M	964656490000	2000	Nos		0.0000	INR Zero Only
7	FT STUD-5/8"-11UNC-2A-118-B8M	964656380000	1000	Nos		0.0000	INR Zero Only
8	HEX NUT-5/8"-11UNC-2B-GR.8M	964656490000 (Same as Sr. No. 6)	2000	Nos		0.0000	INR Zero Only
9	FT STUD-3/4"-10UNC-2A-120-B8M	964656390000	1000	Nos		0.0000	INR Zero Only
10	HEX NUT-3/4"-10UNC-2B-GR.8M	964656500000	2000	Nos		0.0000	INR Zero Only
11	FT STUD-1"-8UNC-2A-158-B8M	964656430000	200	Nos		0.0000	INR Zero Only
12	HEX NUT-1"-8UNC-2B-GR.8M	964656520000	400	Nos		0.0000	INR Zero Only
13	STUD-1076 M10X55	930608660000	500	Nos		0.0000	INR Zero Only
14	NUT -M10 -CL8-IS1364P3	413200001000	500	Nos		0.0000	INR Zero Only
15	BOLT-M 8x75 -8.8-IS1364-P1	412370807500	1500	Nos		0.0000	INR Zero Only
16	NUT -M16 -CL8-IS1364P3-GALV	413200091600	2000	Nos		0.0000	INR Zero Only
17	NUT -M12 -2H BPS 41319	413190001200	1000	Nos		0.0000	INR Zero Only
18	NUT -M10 -CL8-IS1364P3	413200001000 (Same as Sr. No. 14)	5000	Nos		0.0000	INR Zero Only
19	NUT -M10 -2H	413190001000	2000	Nos		0.0000	INR Zero Only
Total in Figures						0.0000	INR Zero Only
Quoted Rate in Words							



SPECIAL TERMS AND CONDITIONS

Tender Enquiry No. 2324-028E Dated 10.07.2023 **Due date 21.07.2023**

Tender Description: Supply of Fasteners GVFST

S1. SCOPE OF SUPPLY

Material shall be supplied as per the applicable TDC/drawing as mentioned in the Table - 1. National & International material standards shall have to be arranged by bidders themselves.

Table 1 : List of Items along with Applicable TDC (Technical Delivery Condition) and Drawing / BPS / IS Standard Number.

Sl. no.	Material Code	Description	Quantity (Nos.)	Material Type	Drawing / BPS / IS Std.	TDC No./ Rev no.	L1 Comparison will be done as (A)
1	964562620000	BOLT-5/8"x70 -B7-N001	1000		3VN00106881/04	TDC:5:164/09	SET
2	964562800000	NUT -5/8" -2H-N025	1000		3VN02506876/03	TDC:5:164/09	(1 Set = 1 Bolt + Nut)
3	964655080000	FT STUD-M33x3.5x220 - B7-0025	200		3V002520729/00	TDC:5:164/09	SET
4	964652740000	NUT -M33x3.5 -2H-3234-H33	400		3V323420717/00	TDC:5:164/09	(1 Set = 1 Stud + 2 Nuts)
5	964656370000	FT STUD-5/8"-11UNC-2A-105-B8M	1000	Stainless Steel	3V000323248/01		SET
6	964656490000	HEX NUT-5/8"-11UNC-2B-GR.8M	2000	Stainless Steel	3V000223249/00		(1 Set = 1 Stud + 2 Nuts)
7	964656380000	FT STUD-5/8"-11UNC-2A-118-B8M	1000	Stainless Steel	3V000423248/01		SET
8	964656490000	HEX NUT-5/8"-11UNC-2B-GR.8M	2000	Stainless Steel	3V000223249/00		(1 Set = 1 Stud + 2 Nuts)
9	964656390000	FT STUD-3/4"-10UNC-2A-120-B8M	1000	Stainless Steel	3V000523248/01		SET
10	964656500000	HEX NUT-3/4"-10UNC-2B-GR.8M	2000	Stainless Steel	3V000323249/00		(1 Set = 1 Stud + 2 Nuts)
11	964656430000	FT STUD-1"-8UNC-2A-158-B8M	200	Stainless Steel	3V000923248/01		SET
12	964656520000	HEX NUT-1"-8UNC-2B-GR.8M	400	Stainless Steel	3V000523249/00		(1 Set = 1 Stud + 2 Nuts)
13	930608660000	STUD-1076 M10X55	500		3V107603661/00	TDC:5:164/09	SET
14	413200001000	NUT -M10 -CL8- IS1364P3	500		IS-1364(P-3)		(1 Set = 1 Stud + 1 Nut)
15	412370807500	BOLT-M 8x75 -8.8- IS1364-P1	1500		IS-1364(P-1)		Number
16	413200091600	NUT -M16 -CL8- IS1364P3-GALV	2000		IS-1364(P-3)		Number
17	413190001200	NUT -M12 -2H BPS 41319	1000		BPS-41319		Number
18	413200001000	NUT -M10 -CL8- IS1364P3	5000		IS-1364(P-3)		Number
19	413190001000	NUT -M10 -2H	2000		BPS-41319		Number

Please take special attention of material type as stainless steel and class of fasteners and quote prices accordingly. For detail technical requirement please check applicable drawing/TDC/BPS/IS standard as mentioned in above list of items.



SPECIAL TERMS AND CONDITIONS

Tender Enquiry No. 2324-028E Dated 10.07.2023 **Due date 21.07.2023**

Tender Description: Supply of Fasteners GVFST

SPECIAL NOTES:

- a) *The L1 evaluation will be done as per Set wise or number wise as per unit of L1 Comparison mentioned in column A of above table, so please take special attention while quoting prices in Part-II (BOQ).*
- b) *Bidder has to submit Unit rate for Each item in the Price Bid/BOQ (Part-II), However evaluation of rates shall be done as per column A (L1 Comparison will be done as). Wherever of L1 Comparison is set, the bidder has to quote for both Bolt/Stud and Nut and also the material should be supply in assembled condition only. Wherever unit of L1 Comparison is number, the comparison will be done number-wise only.*
- c) *Wherever the nuts are repeating that is item Sl. nos. 6 & 8 and 14 & 18 of Table 1, minimum of the quoted rates will be considered for such nuts by the vendor.*
- d) *For item Sl. nos. 30 to 120, 1 SET = 1 STUD AND 2 NUTS.*
- e) *Quality Assurance Plan Applicable :
for Fasteners at Sr. no. 1 to 4 and 13 is document number BHE:QP:FAS:02 dt. 15.03.2019 and for Fasteners at Sr. no. 5 to 12 is document number BHE:SQAP:SS:01 dt. 12.08.2021 (B8M Fasteners) and for Fasteners at Sr. No. 14 to 19, as per Standard.*

ALL THESE ABOVE ITEMS ARE RESERVED FOR MSE MANUFACTURERS ONLY.

In case, no response is received from MSE bidder(s) for these items, then procurement will be made from Non-MSE bidder(s).

S2. PRE-QUALIFICATION CRITERIA (PQC)

Bidder has to submit following documents to fulfil PQC:

1. Supplier shall be manufacturer of Fasteners. Offers from Traders/Dealers/Stockists/agents will summarily be rejected. Submission of Certificate of Registration or UDYAM Certificate or Declaration from bidder for proof as a manufacturer is required to fulfil this criterion.
2. Bidder has to submit one or more purchase order/s of Fasteners from any customer with minimum cumulative value of Rs. 4,00,000 (Four Lacs) along with the proof of execution like Invoice / Consignee Receipt Note / Completion Certificate, from any customer(s). PO date should be 01.07.2020 or afterwards till bid opening date". PO value mentioned above is net of taxes.

The details of the submitted POs along with its proof of execution must be filled as per attached Annexure - P. **Also, please note that the proof of execution like Invoice / Consignee Receipt Note / Completion Certificate must include the Purchase Order reference number, otherwise that PO will not be considered for the fulfilment of this tender term.**

Start-ups shall be exempted from this criterion of Purchase order and invoice submission without any relaxation in quality standards or technical parameters as per D.O. No. 5(4)/2016-BE-I dated 15.02.2017. For claiming Start-Up exemption, vendors have to submit DPIIT (Dept. of Promotion of Industry and Internal Trade)/DIPP (Department for Industrial Policy and Promotion) recognition certificates.

S3. PART-I: TECHNO-COMMERCIAL BID

This tender is through e-procurement mode for supply of "Fasteners GVSFT" as per specifications mentioned in below tender terms. Bidder has to submit their offer on BHEL e-Procurement



SPECIAL TERMS AND CONDITIONS

Tender Enquiry No. 2324-028E Dated 10.07.2023 **Due date 21.07.2023**

Tender Description: Supply of Fasteners GVFST

portal at <https://eprocurebhel.co.in/>. **Offer in any other mode will not be accepted.** Please refer clause no. 1.2 of General Contract Conditions of MM Tenders (GCC), regarding instructions to bidder for submission of offer on BHEL e-procurement portal.

Tenders shall be submitted in Two parts on or before the due date and time indicated in the NIT

Part-I: Techno-Commercial Bid

Bid should contain all the documents/confirmations as per following details:

- a) Acceptance of Techno-Commercial terms and conditions shall be attached along with bid document (Duly filled Part-I Techno-Commercial Bid Questionnaire)

IF THE OFFER IS NOT ACCOMPANIED WITH ACCEPTANCE OF TERMS AND CONDITIONS, IT SHALL BE CONCLUDED THAT ALL THE TERMS AND CONDITIONS ARE ACCEPTABLE AND NO CLAIM WHATSOEVER SHALL BE ENTERTAINED LATER ON.

- b) Documents as per Pre-Qualification Criteria (PQC).
c) Duly filled Annexure - P (Details of Submitted PO and their Proof of Execution, as per above stated PQC term at Sr. no. S2. Cl. 2.)

Part-II: Price Bid

Price Bid as per the attached format.

S4. REVERSE AUCTION

Reverse auction will not be conducted in this tender enquiry.

S5. DELIVERY SCHEDULE

Delivery shall be within 90 days from date of Purchase Order/ Letter of Intent.

S6. LOADING CRITERIA CUM COUNTER OFFER

No counter-offer will be given in this Tender Enquiry.

S7. INSPECTION

Bidders will submit TPI (Third party inspection) / BHEL Inspection report to BHEL IVP after inspection. Then based on Inspection report, BHEL will give dispatch clearance and then only the material shall be supplied to the respective consignee address.

These Special terms & conditions along with NIT and General Contract Conditions (GCC) collectively are the part of tender terms and conditions.



General Conditions of Contract (GCC) of MM Tenders

BHARAT HEAVY ELECTRICALS LIMITED

Industrial Valve Plant: 433, Industrial Complex,
Goindwal Sahib, Dist. Tarn Taran,
Punjab-143422 (INDIA)

TABLE OF CONTENTS

1. Instruction to Bidder	2
2. Scope of Supply	2
3. Price Basis.....	3
4. Discrepancy in Words And Figures.....	3
5. Evaluation in Case of More Than One L-1 Bidder.....	3
6. Reverse Auction.....	4
7. Conflict of Interest among Bidders / Agents	4
8. Validity of Offers.....	5
9. Supplied Material Adjustment.....	5
10. Delivery Schedule.....	5
11. Liquidated Damaged (LD).....	5
12. Acceptance of Material Supplied.....	5
13. Payment Terms	6
14. Taxes & Duties	7
15. Liability Under Reverse Charge (RCM).....	7
16. Access to Manufacturing Premises.....	7
17. Inspection.....	7
18. Warrantee and Corresponding Repair / Replacement of Goods.....	8
19. LOI (Letter of Intent).....	9
20. Sub-Contract	9
21. Risk Purchase.....	9
22. Force Majeure	9
23. Non-Disclosure Agreement	10
24. Clarifications.....	10
25. Preferences for Micro and Small Enterprises (MSEs).....	10
26. Preference to Make in India.....	11
27. Restrictions Under Rule 144(XI) of The General Financial Rules (GFR), 2017	11
28. Resolution of Disputes.....	12
29. Fraud Prevention Policy.....	13
30. Preventive Checks to Eliminate Suspected Cartel Formation	13
31. Suspension of Business Dealings with Suppliers / Contractors	14
32. General.....	14
Annexure-X.....	17
Appendix-I of Annexure-X.....	23
Appendix-II of Annexure-X	24
Appendix-III of Annexure-X	25





General Conditions of Contract (GCC) of MM Tenders

BHARAT HEAVY ELECTRICALS LIMITED

Industrial Valve Plant: 433, Industrial Complex,
Goindwal Sahib, Dist. Tarn Taran,
Punjab-143422 (INDIA)

1. Instruction to Bidder

Quotations shall be submitted before due date and time. Late offers are liable to be rejected, so please ensure to submit bid well within due date and time. Techno-commercial part will be opened on due date.

Based on evaluation of techno-commercial offers, Price bids of bidders who qualify from techno-commercial evaluation shall be opened. BHEL may decide to open the Price bid same day at 1700 hrs. If not opened on the same day, all qualifying bidders shall be notified for date of opening of Price bids by email/fax/post/courier/E-procurement system generated email.

1.1 Instruction to Bidder (In case of Non-E-Procurement / Paper/ Manual/ Hard Copy based tenders)

Sealed Tenders can be dropped in the tender box labeled as 'Tender box for MM contracts'. This tender box is located at the entrance of Admin block BHEL Goindwal. Quotations can also be submitted through e-mail at tendermm_ivp@bhel.in. Offers received in time shall be considered only when offers are complete in all respects. In case of bulky tenders, please handover quotation to Sh. Rakesh Kumar/SDGM - Head-MM or Sh. Sumeet Bansal / Sr. Manager - MM [Contact: 01859 224 615 / 628]. Bid can be sent to following address:

**BHEL, Industrial Valve Plant,
#433, Industrial Complex,
Goindwal Sahib, Distt. Tarn Taran,
Punjab-143422.**

1.2 Instruction to bidder (In case of E-Procurement)

1. Interested bidders / suppliers shall submit their offer through e-procurement mode at <https://eprocurebhel.co.in/>.
2. **Offers in any other mode will not be accepted.**
3. Procedure for submission of tender is available in the "Bidder Manual Kit" at e-tender portal <https://eprocurebhel.co.in/>.
4. In case of any difficulty faced while registering on BHEL's e-Procurement portal developed by NIC, queries may be addressed to 0120-4001002, 0120-4001005 and 0120-6277787; email: support-eproc@nic.in. These details are also available on 'Contact Us' page of the portal.
5. Before uploading scanned documents if any, the bidders shall sign on all the statements, documents, certificates uploaded by him, owning responsibility for their correctness / authenticity.
6. **Disclaimer clause:** Neither the Organization (Bharat Heavy Electricals Ltd.) nor the service provider is responsible for any failure of submission of bids due to failure of internet or other connectivity problems or reasons thereof.

2. Scope of Supply

Material shall be supplied as per the applicable latest Technical Delivery Conditions (TDC)/ Material Standard requirements/BPS/Drawing and other requirement as given in the Tender Enquiry. National & International material Standards shall have to be arranged by vendors themselves. Latest applicable revisions of standards/procedures to be referred.





General Conditions of Contract (GCC) of MM Tenders

BHARAT HEAVY ELECTRICALS LIMITED

Industrial Valve Plant: 433, Industrial Complex,
Goindwal Sahib, Dist. Tarn Taran,
Punjab-143422 (INDIA)

All required tests as called in referred material standard/BHEL/TDC/drawing etc. shall be carried out by vendor at no extra cost. Material Test Certificates (MTC), inspection reports and Compliance/Guarantee Certificate are to be provided along with the supplies.

3. Price Basis

1. Order of enquiry item sl. no. shall be maintained in the quotation.
2. The rates quoted shall be firm and fixed. No price variation is proposed and allowed.
3. Rates quoted should be FOR BHEL Goindwal basis. The offers quoted on other than FOR Goindwal basis are liable to be rejected.

In case bidder has quoted Ex-works prices, then he/she will be given an opportunity to accept price basis as FOR Goindwal either by accepting delivery as FOR Goindwal in same quoted price or by providing loading factor on his/her quoted ex-works prices to make them FOR prices.

Variation in GST or any other statutory levies during contractual delivery period shall be to BHEL's account.

4. Discrepancy in Words And Figures

1. If, in the price structure quoted for the required goods/ services/ works, there is discrepancy between the unit price and the total price (which is obtained by multiplying the unit price by the quantity}, the unit price shall prevail and the total price corrected accordingly, unless in the opinion of the purchaser there is an obvious misplacement of the decimal point in the unit price, in which case the total price as quoted shall govern and the unit price corrected accordingly.
2. If there is an error in a total corresponding to the addition or subtraction of subtotals, the subtotals shall prevail and the total shall be corrected; and
3. If there is a discrepancy between words and figures, the amount in words shall prevail, unless the amount expressed in words is related to an arithmetic error, in which case the amount in figures shall prevail subject of (a) and (b) above.
4. If there is such discrepancy in an offer, the same shall be conveyed to the bidder with target date upto which the bidder has to send his acceptance on the above lines and if the bidder does not agree to the decision of the purchaser, the bid is liable to be ignored.
5. Bids should be free from correction, overwriting, using corrective fluid, etc. Any interlineation, cutting, erasure or overwriting shall be valid only if they are attested under full signature(s) of person(s) signing the bid else shall be liable for rejection.
6. All overwriting/cutting, etc will be numbered by bid opening officials and announced during bid opening.

5. Evaluation in Case of More Than One L-1 Bidder

In the course of evaluation, if more than one bidder happens to occupy L1 status, effective L1 will be decided by soliciting discounts from the respective L1 bidders.

In case more than one bidder happens to occupy the L1 status even after soliciting discounts, the L1 bidder shall be decided by a toss / draw of lots, in the presence of the respective L1 bidder(s) or their representative(s).

Ranking will be done accordingly. BHEL's decision in such situations shall be final and binding.

Signature Not Verified
Signed By: RAKESH
KUMAR
Location: BHEL, Goindwal
Signing Date: 05.04.2023





General Conditions of Contract (GCC) of MM Tenders

BHARAT HEAVY ELECTRICALS LIMITED

Industrial Valve Plant: 433, Industrial Complex,
Goindwal Sahib, Dist. Tarn Taran,
Punjab-143422 (INDIA)

6. Reverse Auction

In case, it is declared in special terms & conditions of tender enquiry that RA is applicable for the NIT, then RA will be conducted as per following clause:

BHEL shall be resorting to Reverse Auction (RA) (Guidelines as available on <https://www.bhel.com/>) for this tender. RA shall be conducted among the techno-commercially qualified bidders as per RA guidelines.

Price bids of all techno-commercially qualified bidders shall be opened and same shall be considered for RA. In case any bidder(s) do(es) not participate in online Reverse Auction, their sealed envelope price bid along with applicable loading, if any, shall be considered for ranking.

7. Conflict of Interest among Bidders / Agents

A bidder shall not have conflict of interest with other bidders. Such conflict of interest can lead to anti-competitive practices to the detriment of Procuring Entity's interests. ***The bidder found to have a conflict of interest shall be disqualified.*** A bidder may be considered to have a conflict of interest with one or more parties in this bidding process, if:

- a) they have controlling partner (s) in common; **or**
- b) they receive or have received any direct or indirect subsidy/ financial stake from any of them; **or**
- c) they have the same legal representative/agent for purposes of this bid; **or**
- d) they have relationship with each other, directly or through common third parties, that puts them in a position to have access to information about or influence on the bid of another Bidder; **or**
- e) Bidder participates in more than one bid in this bidding process. Participation by a Bidder in more than one Bid will result in the disqualification of all bids in which the parties are involved. However, this does not limit the inclusion of the components/ sub-assembly/ Assemblies from one bidding manufacturer in more than one bid. **or**
- f) In cases of agents quoting in offshore procurements, on behalf of their principal manufacturers, one agent cannot represent two manufacturers or quote on their behalf in a particular tender enquiry. One manufacturer can also authorise only one agent/dealer. There can be only one bid from the following:
 1. The principal manufacturer directly or through one Indian agent on his behalf; and
 2. Indian/foreign agent on behalf of only one principal.**or**
- g) a Bidder or any of its affiliates participated as a consultant in the preparation of the design or technical specifications of the contract that is the subject of the Bid; **or**
- h) In case of a holding company having more than one independently manufacturing units, or more than one unit having common business ownership/management, only one unit should quote. Similar restrictions would apply to closely related sister companies. Bidders must proactively declare such sister/ common business/ management units in same/ similar line of business.





General Conditions of Contract (GCC) of MM Tenders

BHARAT HEAVY ELECTRICALS LIMITED

Industrial Valve Plant: 433, Industrial Complex,
Goindwal Sahib, Dist. Tarn Taran,
Punjab-143422 (INDIA)

8. Validity of Offers

The offers shall be kept open for acceptance 'for number of days mentioned in special terms and conditions' from the date of opening of the tender. In case of tender extension, the bid validity shall be considered from the date of tender opening.

9. Supplied Material Adjustment

Item/s pending in previous PO has to be billed in previous PO only. Otherwise, BHEL will be free to adjust the supplies in previous PO. Any implication of tax will be on supplier's account. For this it is desirable that vendor should reconcile the pending PO statement every month/frequently with BHEL. Vendor can also view these details at Portal (<https://trichy.bhel.com/mm/index.jsp>).

10. Delivery Schedule

Supplies shall be affected and completed as per schedule mentioned in special terms and conditions. Commencement of delivery period shall be reckoned from the date of PO / LOI or any other agreed milestone.

11. Liquidated Damaged (LD)

- Time is the essence of the contract.
- The ordered items shall be delivered as per the delivery period mentioned in the Purchase Order.
- In case the supplier supplies the ordered items beyond the delivery period specified, Liquidated Damages -LD - as detailed below shall be will be levied from the supplier without prejudice to any other relief /compensation available to BHEL, Punjab under any other condition of the contract/applicable legal provisions.
- Failure to dispatch the materials in the time as per the delivery mentioned in our Purchase Order (PO) would make the supplier liable to an un-conditional LD at the rate of 0.5% of the undelivered order value per week of the delay or part thereof subject to a maximum of 10% of the undelivered order value.
- Any deviation from the above LD clause, loading will be applied to the extent to which it is not agreed by the bidder (at offered value).
- Indigenous: In case of Ex-works delivery terms, the document date (Invoice/Challan date) in Goods Receipt (GR) document shall be reckoned for LD deduction. In case of FOR Delivery terms, the posting date in GR document shall be reckoned for LD deduction.
- Import: For CFR terms, BL date will be considered for LD calculation.

BHEL reserves the right to receive or not receive the material after the due date of PO. Applicable GST shall also be recovered from suppliers/contractors on LD amount. For this Debit note will be issued by BHEL indicating the respective supply invoice number.

12. Acceptance of Material Supplied

- The supply shall strictly as per the specifications in the tender /purchase order.
- Delivery of the ordered items as per the delivery terms in the Purchase Order does not automatically constitute acceptance of the delivered items.
- Acceptance of the materials supplied will be based on the inspection and certification documents by the supplier as stipulated in the Purchase order. However, BHEL reserves the right to test the

Signature Not Verified

Signed By: RAKESH

KUMAR

Location: BHEL, Goindwal

Signing Date: 05.04.2023





General Conditions of Contract (GCC) of MM Tenders

BHARAT HEAVY ELECTRICALS LIMITED

Industrial Valve Plant: 433, Industrial Complex,
Goindwal Sahib, Dist. Tarn Taran,
Punjab-143422 (INDIA)

material supplied, if required, at BHEL Lab or any other approved/accredited lab and the result will be binding on the supplier.

4. The acceptance or otherwise of the delivered items will be separately communicated to the supplier by BHEL through B2B portal within 15 days from the delivery of items or delivery of the required test certificates /other documents whichever is later.
5. In case of rejection of the delivered items, either part or full, the vendor shall replace the rejected items as per the specification in the Purchase order/tender at their cost within 30 days of communication of rejection to the supplier. The supplier shall be given maximum two opportunities to replace the rejected items.
6. After the clearance of the 1st lot, in case of rejection of the delivered items, either part or full, if the supplier fails to replace the rejected items within 30 days of communication of the rejection, the same shall be treated as failure to execute the contract and actions as per the Guidelines for Suspension of Business Dealings with Suppliers /Contractors available in the webpage: <https://www.bhel.com> would be taken against such supplier.

13. Payment Terms

1. Payments shall be made to the Seller within the mentioned days (as per below table) from the date of receipt and acceptance of material.

Type of Bidder	Payment Terms (Number of days)
Micro & Small Enterprises (MSEs)	45 days
Medium Enterprises	60 days
Non MSME	90 days

To be considered as Micro, Small or Medium enterprise, bidder must be manufacturer of offer product and relevant valid certificate as per latest MSME guidelines is to be submitted along with bid.

MSME bidders can avail benefits of payment through TReDS (Trade Receivable e Discounting System).

In case of any deviation from standard payment term mentioned above, BHEL shall load on the item price at 'Base rate of SBI (as applicable on the date of bid opening; Techno-commercial bid opening) + 6% for the period of relaxation sought by bidders.

2. Documents to be submitted (if applicable)
 - i) Tax invoice (Invoice shall be GST compliant and should contains all the required information such as GST No, HSN code etc.)
 - ii) Transporter copy along with material/consignment.
 - iii) Material Test Certificates (MTC) and
 - iv) Compliance Certificate.
3. GST registration number is to be submitted by qualified vendor as per GST law.
4. It is mandatory to mention proper material codes in the invoices and separate invoices to be raised for different POs.
5. **BHEL releases payment through EFT mode ONLY. Necessary details may please be submitted by filling required format before release of payment.**





General Conditions of Contract (GCC) of MM Tenders

BHARAT HEAVY ELECTRICALS LIMITED

Industrial Valve Plant: 433, Industrial Complex,
Goindwal Sahib, Dist. Tarn Taran,
Punjab-143422 (INDIA)

14. Taxes & Duties

Payment of GST portion will be released to vendor only upon completion of statutory requirement and further subject to following:

- Vendor declaring such invoice in his GSTR-1 and
- Receipt of goods and Tax invoice by BHEL and
- Confirmation of payment of GST thereon by vendor on GSTN portal.
- Above is subject to receipt of goods/service and tax invoice thereof along with vendor declaring invoice in his return and paying GST within timeline prescribed for availing ITC by BHEL.

Following may please be noted for availing Input Tax Credit (ITC) by BHEL:

- Since ITC can be availed only when BHEL is in possession of GST Tax invoice and after receipt of goods. Thus, vendor to ensure timely dispatch of goods and Tax invoice. It may be noted that in case of any delay in receipt of Tax Invoice and/or receipt of goods, the ITC availment by BHEL will get delayed thus entailing additional cash outflow & may even get denied if ITC availment timelines are breached.
- Further ITC can be availed only when vendor has declared such invoice in his outward supply Return GSTR-1 and after GST thereon has been paid by him at the time of filing of monthly Return.
- If GST credit is delayed/denied to BHEL due to non/delayed receipt of goods and/or tax invoice or expiry of timeline prescribed in GST law for availing such ITC, or any other reasons not attributable to BHEL, GST amount shall be recoverable from vendor along with interest levied/leviable on BHEL.
- Further, in case vendor delays declaring such invoice in his return and GST credit availed by BHEL is denied or reversed subsequently as per GST law, GST amount paid by BHEL towards such ITC reversal as per GST law shall be recoverable from vendor/contractor along with interest levied/leviable on BHEL.

15. Liability Under Reverse Charge (RCM)

Any GST liability arising on BHEL under Reverse Charge (RCM) before actual receipt of goods and/ or Invoice thereof would be subject to recovery of Interest leviable for the period between the date of such liability and actual date of eligibility of ITC based on receipt of goods, receipt of Invoices and other conditions specified in GST Law as applicable.

16. Access to Manufacturing Premises

While Purchase Orders placed on the vendor are under execution, authorized representatives of BHEL shall be allowed free access to the manufacturing facilities for the purpose of inspection or monitoring the progress of purchase orders. This access will also be extended to representatives of BHEL's customers accompanying the authorized representative/s of BHEL (which shall be intimated in advance), if our contractual requirements with our customers call for the same.

17. Inspection

- The seller shall give adequate notice, of 1 week or as mutually agreed period, in writing to the Purchaser about the date and place at which the goods will be ready for inspection/ testing, as provided for in the contract.





General Conditions of Contract (GCC) of MM Tenders

BHARAT HEAVY ELECTRICALS LIMITED

Industrial Valve Plant: 433, Industrial Complex,
Goindwal Sahib, Dist. Tarn Taran,
Punjab-143422 (INDIA)

2. Purchaser or his authorized representative shall be entitled to carry out inspection of material and workmanship/Surveillance Audit at Seller's premises or at his sub-contractor's premises at all reasonable times during execution of contract; Such inspection, examination and testing, if made, shall not absolve the Seller from his obligations under the contract. No additional charges shall be claimed for such inspections. Moreover, all required infrastructure (testing, tools etc) have to be arranged by supplier.
3. Any inspection carried out before supply by vendor/incoming stage at BHEL notwithstanding, if any defect/non-conformity is noted during processing, the same shall be attended/replaced by vendor at no extra cost.
4. BHEL representative from unit or CQ is authorized to carry out audits along with TPIA at vendor's works before clearing the items for dispatch.
5. Necessary tooling including thread gauges etc. have to be arranged by vendor. Only in exceptional cases, based on BHEL discretions item/nature, BHEL may consider request to provide gauges if available with BHEL. But in no case this shall be linked with delivery of material.

18. Warrantee and Corresponding Repair / Replacement of Goods

Goods shall comply with the specifications for material, workmanship and performance. Unless otherwise specified, vendor shall give a warrantee against design & manufacturing defects for a period of 18 months from the date of receipt. In case of non-acceptance of this term, bid shall be liable for rejection.

If the delivery is found non-compliant during the warranty period, leading to rejection, the Seller shall arrange free replacement / repair of goods, within one month from the date of intimation. Corresponding quantity shall be treated as unsupplied against respective purchase order till replacement is received at BHEL. In the event of the Seller's failure to comply, Purchaser may take action as appropriate, including repair / replenish rejected goods, at the risk & cost of the Seller.

All incidental charges like freight, insurance and customs duty in respect of return of defective items are to vendor's account only. BHEL will inform related invoice, quantity etc. to supplier. Supplier has to give advance intimation / plan (Transporter, Vehicle details) for the lifting of material. Further supplier has to provide requisite documents (such as Credit Note, e-Way Bill etc.) to lift the rejected material. Material should be lifted within one month from date of intimation. After one-month, BHEL will not be responsible for rejected material and BHEL shall have the right to dispose off such rejected material.

The defective parts and components shall be collected by your Indian agent or / authorized person, only after completing the replacement / repairs. If the supplier fails to replace / rectify the defective/ damaged items on free of cost within one month of reporting from our end, the same shall be treated as failure to execute the contract and actions as per the Guidelines for Suspension of Business Dealings with Suppliers /Contractors available in the webpage: <https://www.bhel.com> would be taken against such supplier without prejudice to the other remedies available to BHEL under the contract and law in this regard.





General Conditions of Contract (GCC) of MM Tenders

BHARAT HEAVY ELECTRICALS LIMITED

Industrial Valve Plant: 433, Industrial Complex,
Goindwal Sahib, Dist. Tarn Taran,
Punjab-143422 (INDIA)

19. LOI (Letter of Intent)

BHEL may issue LOI prior to the PO for any reason whatsoever. The LOI in such cases is to be treated as PO for all practical purposes and all the Terms & Conditions of the tender shall be applicable from the date of issue of LOI.

20. Sub-Contract

The purchase order or any part thereof shall not be sub-contracted, assigned or otherwise transferred without previously obtaining the BHEL's consent in writing.

21. Risk Purchase

1. In the event of any successful Tenderer's failure to fulfil any of the tender / Contract obligations including supply of whole or any part of the ordered items as per Contract / Agreement, BHEL has the right to terminate the contract and purchase from elsewhere, at the risk and cost of the defaulted supplier, either the whole of the goods or any part which the supplier has failed to deliver or dispatch within the time stipulated in the contract or if the same were not available, the best and nearest available substitute thereof. The supplier shall be liable for the additional expenditure/difference in Cost, if any, including consequential losses which BHEL may sustain by reason of risk purchase in addition to the applicable LD as per the Purchase order/contract.
2. The decision of BHEL with regard to the additional expenditure / difference in cost and consequential losses incurred by BHEL shall be final and binding on the supplier.
3. The amount recoverable under risk purchase shall be recovered from the defaulted supplier in all or any of the following manners:
 - from dues available in the form of Bills payable to defaulted supplier, SD, BGs against the same contract.
 - from the dues payable to defaulted supplier against other contracts in the same Region/Unit /any other region/unit. In-case recoveries are not possible with any of the above available options, Legal action shall be initiated for recovery against defaulted supplier.

22. Force Majeure

1. Notwithstanding the provisions contained in other clauses, the supplier shall not be liable for imposition of any such sanction so long the delay and/or failure of the supplier in fulfilling its obligations under the contract is the result of an event of Force Majeure. For purposes of this clause, Force Majeure means an event beyond the control of the supplier and not involving the supplier's fault or negligence and which is not foreseeable and not brought about at the instance of the party claiming to be affected by such event and which has caused the non – performance or delay in performance. Such events may include, but are not restricted to, wars or revolutions, hostility, acts of public enemy, civil commotion, sabotage, fires, floods, explosions, epidemics, quarantine restrictions, strikes excluding by its employees, lockouts excluding by its management, freight embargoes and Acts of GOD.
2. If a Force Majeure situation arises, the supplier shall promptly notify the Purchaser/Consignee in writing of such conditions and the cause thereof within twenty-one days of occurrence of such event. Unless otherwise directed by the Purchaser/Consignee in writing, the supplier shall continue to perform its obligations under the contract as far as reasonably practical, and shall seek all reasonable alternative means for performance not prevented by the Force Majeure event.

Signature Not Verified

Signed By: RAKESH

KUMAR

Location: BHEL, Goindwal

Signing Date: 05.04.2023





General Conditions of Contract (GCC) of MM Tenders

BHARAT HEAVY ELECTRICALS LIMITED

Industrial Valve Plant: 433, Industrial Complex,
Goindwal Sahib, Dist. Tarn Taran,
Punjab-143422 (INDIA)

3. If the performance in whole or in part or any obligation under this contract is prevented or delayed by any reason of Force Majeure for a period exceeding sixty days, either party may at its option terminate the contract without any financial repercussion on either side.
4. In case due to a Force Majeure event the Purchaser/Consignee is unable to fulfil its contractual commitment and responsibility, the Purchaser/Consignee will notify the supplier accordingly and subsequent actions taken on similar lines described in above sub-paragraphs.

23. Non-Disclosure Agreement

All Drawing and technical documents relating to the product or it's manufacture submitted by one party to the other, prior or subsequent to the formation of contract, shall remain property of the submitting party. Drawing, technical documents or other technical information received by one party, shall not without the consent of the other party, be used for any other purpose than that, for which they were provided. Such technical information shall not without the consent of the submitting party, otherwise be used or copied, reproduced, transmitted or communicated to a third party. Patterns supplied by BHEL will remain BHEL's property which shall be returned by the bidder on demand to BHEL. Bidder shall in no way share or use such intellectual property of BHEL to promote his own business with others. ***BHEL reserves the right to claim damages from the bidder, or take appropriate penal action as deemed fit against the bidder, for any infringement of the provisions contained herein.***

24. Clarifications

The correspondence exchanged against the tender from both tenderer and BHEL through email/e-procurement are considered as valid document legally though it is not signed. It is treated as valid confirmations made on behalf of the respective company and very much comes under the legal ambit of the business transaction and hence it is binding on both the parties to the business. Any transaction pertaining to the tender from both the parties of business done round the clock irrespective of the office or business hours of the companies, are valid legally and binding on both the parties. This applies to the extent only in such cases where deadline time for transaction is not specifically declared by either or both the parties to the business.

25. Preferences for Micro and Small Enterprises (MSEs)

Preferences as mentioned in “Public Procurement Policy for Micro and Small Enterprises (MSEs) Order, 2012” & “Public Procurement Policy for Micro and Small Enterprises (MSEs) Amendment Order, 2018”, or as per latest guidelines issued by government shall be given to Micro and Small enterprises.

Main points which are mentioned in the above orders are as follows:

- 25% Procurement of the tender value shall be made from MSE (Micro, Small Enterprises) firms.
- 25% of the 25% quantity (i.e. 6.25% of the tender quantity) offered to the MSE's shall be reserved for MSE's owned by SC/STs. Failure to participate by any MSE owned by SC/ST's; this 6.25% quantity shall be procured from other MSEs.





General Conditions of Contract (GCC) of MM Tenders

BHARAT HEAVY ELECTRICALS LIMITED

Industrial Valve Plant: 433, Industrial Complex,
Goindwal Sahib, Dist. Tarn Taran,
Punjab-143422 (INDIA)

- 3% from within the 25% quantity offered to the MSE's shall be reserved for women owned MSE's. Failure to participate by any MSE owned by women; this 3% quantity shall be procured from other MSEs.
- EMD shall be exempted for MSE's. All these benefits are subject to production of all statutory documents
- In tender, participating Micro and Small Enterprises quoting price within price band of L1+15 per cent shall also be allowed to supply a portion of requirement by bringing down their price to L1 price in a situation where L1 price is from someone other than a Micro and Small Enterprise and such Micro and Small Enterprise shall be allowed to supply up to 25 per cent of total tendered value. In case of more than one such Micro and Small Enterprise, the supply shall be shared proportionately (to tendered quantity).

MSE suppliers can avail the intended benefits only if they submit **Udyam Registration Certificate** along with the offer. No other document shall be considered for availing MSE benefits. Non-submission of such document will lead to consideration of their bid at par with other bidders. No benefit shall be applicable for this enquiry if any deficiency in the above required documents is not cleared before price bid opening. If the tender is to be submitted through e-procurement portal, then the above required document is to be uploaded on the portal.

Note: It may however be noted that MSE guidelines as on date (Date of Technical Bid Opening Part-1) shall prevail.

26. Preference to Make in India

This procurement shall be governed by notification no. P-45021/2/2017-PP (BE-II) dated 16.09.2020 of Government of India issued by DPIIT and subsequent circulars issued afterwards. Accordingly, the minimum local content, the margin of purchase preference and the procedure for purchase preference to make in India shall be adhered.

27. Restrictions Under Rule 144(XI) of The General Financial Rules (GFR), 2017

All provisions of Order No. F.No.6/18/2019-PPD of Department of Expenditure (DoE) shall be applicable for this tender enquiry (Order copy is available at <https://doe.gov.in/procurementpolicy-divisions>). Accordingly, any bidder from a country which shares a land border with India (except the countries to which the Govt. of India has extended lines of credit or in which the Govt. of India is engaged in development projects for which list is available at <https://www.mea.gov.in/>) will be eligible to bid in this tender only if the bidder is registered with the Competent Authority as specified in Annex I of the said Order of DoE.

Updated list of the countries to which lines of credit have been extended or in which development projects are undertaken are available on the Ministry of External affairs website (<https://www.mea.gov.in/>)

For the purpose of this order, definition of Bidder from a country which shares a land border with India shall be same as defined in the Annex III of the said order.





General Conditions of Contract (GCC) of MM Tenders

BHARAT HEAVY ELECTRICALS LIMITED

Industrial Valve Plant: 433, Industrial Complex,
Goindwal Sahib, Dist. Tarn Taran,
Punjab-143422 (INDIA)

Registration with the competent authority as stipulated in the said order is responsibility of bidder.
Bidder has to submit a certificate certifying following along with offer:

"I have read the clause regarding restrictions on procurement from a bidder of a country which shares a land border with India; I certify that this bidder is not from such a country or, if from such a country, has been registered with the Competent Authority. I hereby certify that this bidder fulfils all requirements in this regard and is eligible to be considered. [Where applicable, evidence of valid registration by the Competent Authority shall be Attached]."

28. Resolution of Disputes

The Parties agree that if at any time (whether before, during or after the arbitral or judicial proceedings), any Disputes (which term shall mean and include any dispute, difference, question or disagreement arising in connection with construction, meaning, operation, effect, interpretation or breach of the contract/tender which the Parties are unable to settle mutually), arise inter-se the Parties, the same may, be referred by either party to Conciliation to be conducted through Independent Experts Committee to be appointed by competent authority of BHEL from the BHEL Panel of Conciliators.

Notes:

1. No serving or a retired employee of BHEL/Administrative Ministry of BHEL shall be included in the BHEL Panel of Conciliators.
2. Any other person(s) can be appointed as Conciliator(s) who is/are mutually agreeable to both the parties from outside the BHEL Panel of Conciliators.

The proceedings of Conciliation shall broadly be governed by Part-III of the Arbitration and Conciliation Act 1996 or any statutory modification thereof and as provided in Annexure-X to this GCC.

The Annexure-X together with its appendices will be treated as if the same is part and parcel hereof and shall be as effectual as if set out herein in this GCC.

Except as provided elsewhere in this Contract, in case amicable settlement is not reached between the parties, in respect of any dispute or difference; arising out of the formation, breach, termination, validity or execution of the Contract; or, the respective rights and liabilities of the Parties; or, in relation to interpretation of any provision of the Contract; or, in any manner touching upon the Contract, then, either Party may, by a notice in writing to other Party, refer such dispute or difference to sole arbitration of an arbitrator appointed as per the Arbitration and Conciliation Act, 1996 (India) or statutory modification or re-enactment thereof and the rules made thereunder and for the time being in force.

The Arbitrator shall pass a reasoned award and the award of the Arbitrator shall be final and binding upon the parties.

This contract shall be governed, construed and interpreted in accordance with the laws of India.





General Conditions of Contract (GCC) of MM Tenders

BHARAT HEAVY ELECTRICALS LIMITED

Industrial Valve Plant: 433, Industrial Complex,
Goindwal Sahib, Dist. Tarn Taran,
Punjab-143422 (INDIA)

Subject as aforesaid, the provisions of Arbitration & Conciliation Act 1996 (India) or statutory modification or re-enactment thereof and the rules made thereunder and for the time being in force shall apply to the arbitration proceeding under this clause.

The seat of arbitration shall be Tarn Taran, Punjab, India.

The cost of arbitration shall be borne as per the award of the Arbitrator.

Subject to arbitration in terms of clause above, the Courts at Tarn Taran, Punjab, India shall have exclusive jurisdiction over any matter arising out of or in connection with this Contract.

Notwithstanding the existence or any dispute or difference and/or reference for the arbitration, the vendor/contractor shall proceed with and continue without hindrance the performance of its obligation under this Contract with due diligence and expedition in a professional manner except where the Contract has been terminated by either Party in terms of this Contract.

In Case of Contract with Public Sector Enterprise (PSE) or a Government Department, the following shall be applicable:

In the event of any dispute or difference relating to the interpretation and application of the provisions of commercial contract(s) between Central Public Sector Enterprises (CPSEs)/Port Trusts inter se and also between CPSEs and Government Departments/Organizations (Excluding disputes concerning Railways, Income Tax, Customs & Excise Departments, such dispute or difference shall be taken up by either party for its resolution through AMRCD as mentioned in DPE OM No.05/003/2019-FTS-10937 dated 14th December, 2022 and the decision of AMRCD on the said dispute will be binding on both the parties.”

Set off : BHEL shall have the right to recover any money which in the sole opinion of BHEL is due from the supplier from any money due to the supplier under this Contract or any other contract or from the Security Deposit/BG furnished by the supplier under this Contract or any other contract.

29. Fraud Prevention Policy

The Bidder along with its associate / collaborators / sub-contractors / sub-vendors / consultants / service providers shall strictly adhere to BHEL Fraud Prevention Policy displayed on BHEL website <https://www.bhel.com/> and shall immediately bring to the notice of BHEL management about any fraud or suspected fraud as soon as it comes to their notice.

30. Preventive Checks to Eliminate Suspected Cartel Formation

The Bidder declares that they will not enter into any illegal or undisclosed agreement or understanding, whether formal or informal with other Bidder(s). This applies in particular to prices, specifications, certifications, subsidiary contracts, submission or non-submission of bids or any other actions to restrict competitiveness or to introduce cartelization in the bidding process.





General Conditions of Contract (GCC) of MM Tenders

BHARAT HEAVY ELECTRICALS LIMITED

Industrial Valve Plant: 433, Industrial Complex,
Goindwal Sahib, Dist. Tarn Taran,
Punjab-143422 (INDIA)

In case, the Bidder is found having indulged in above activities, suitable action shall be taken by BHEL as per extant policies/ guidelines.

31. Suspension of Business Dealings with Suppliers / Contractors

The offers of the bidders who are under suspension as also the offers of the bidders, who engage the services of the firms debarred across BHEL, shall be rejected. The list of firms debarred across BHEL is available on BHEL web site <https://www.bhel.com/>.

INTEGRITY COMMITMENT, PERFORMANCE OF THE CONTRACT AND PUNITIVE ACTION THEREOF:

31.1. Commitment by BHEL:

BHEL commits to take all measures necessary to prevent corruption in connection with the tender process and execution of the contract. BHEL will during the tender process treat all Bidder(s) in a transparent and fair manner, and with equity.

31.2. Commitment by Bidder/ Supplier/ Contractor:

31.2.1. The bidder/ supplier/ contractor commits to take all measures to prevent corruption and will not directly or indirectly influence any decision or benefit which he is not legally entitled to nor will act or omit in any manner which tantamount to an offence punishable under any provision of the Indian Penal Code, 1860 or any other law in force in India.

31.2.2. The bidder/ supplier/ contractor will, when presenting his bid, disclose any and all payments he has made, and is committed to or intends to make to agents, brokers or any other intermediaries in connection with the award of the contract and shall adhere to relevant guidelines issued from time to time by Govt. of India/ BHEL.

31.2.3. The bidder/ supplier/ contractor will perform/ execute the contract as per the contract terms & conditions and will not default without any reasonable cause, which causes loss of business/ money/ reputation, to BHEL.

If any bidder/ supplier/ contractor during pre-tendering/ tendering/ post tendering/ award/ execution/ post-execution stage indulges in mal-practices, cheating, bribery, fraud or and other misconduct or formation of cartel so as to influence the bidding process or influence the price or acts or omits in any manner which tantamount to an offence punishable under any provision of the Indian Penal Code, 1860 or any other law in force in India, then, action may be taken against such bidder/ supplier/ contractor as per extant guidelines of the company available on <https://www.bhel.com/> and/or under applicable legal provisions

32. General

1. BHEL will not be bound by any power of attorney granted by the vendors or by changes in the composition of the firm made subsequent to the execution of the contract. They may, however,





General Conditions of Contract (GCC) of MM Tenders

BHARAT HEAVY ELECTRICALS LIMITED

Industrial Valve Plant: 433, Industrial Complex,
Goindwal Sahib, Dist. Tarn Taran,
Punjab-143422 (INDIA)

- recognize such power of attorney and changes after obtaining proper legal advice, the cost of which will be chargeable to the vendor concerned.
2. BHEL reserves the right to extend the due date of opening, which shall be informed. Validity of offer shall be deemed to be revised accordingly.
 3. BHEL reserves the right to accept or reject any part or whole of the tender of a bidder by assigning a valid reason thereof. BHEL reserves the right to cancel the tender without assigning any reason thereof and without any obligation before any commitment.
 4. Acceptance of all terms and conditions, in the form of signed copy of T&C or confirmation separately written, shall be submitted along with quotation. If nothing is mentioned, it shall be concluded that these terms and conditions are acceptable.
 5. BHEL may increase/decrease item/s based on BHEL requirement before price bid opening. Suitable price implication may be asked from suppliers.
 6. BHEL may drop item/items from tender at any stage of tender before placing PO. BHEL may also delete PO with consent with supplier within delivery date of PO.
 7. After releasing PO, it is assumed that supplier has accepted PO if we do not receive acknowledgement from supplier within 5 days of date of PO.
 8. In case of unscheduled holiday on opening day of tender, the next working day will be treated as scheduled prescribed day of opening of tender.
 9. On the due date of tender opening, only technical bids will be opened. The opened technical bids will be evaluated by us and clarifications required, if any, will be called for from the bidders on technical and commercial points. If no reply is received from the vendor for the clarification raised by BHEL with in the final cut-off date, those vendors offer will be processed with the documents available / submitted against this tender. Offers not meeting the required specification and technical condition will be summarily rejected. The price bids of technically suitable bidders will be opened on a later date with prior intimation to techno-commercially suitable bidders.
 10. Ranking L-1, L-2 etc. shall be done for individual item for the techno-commercially acceptable offers on landed cost to BHEL, IVP Goindwal basis and BHEL reserves the right to place order for individual items with different vendors.
 11. BHEL reserves the right to negotiate with L1 vendor or re-float the tender for items where, L1 price is not the lowest acceptable price; BHEL reserves the right to increase or decrease the tender quantity.
 12. If supplier is mentioning delivery destination within state/ outside state depending upon his location of factory, Free on Road etc. these are assumed as on FOR Goindwal. If supplier is wishing to give delivery on Ex works basis, then he has to clearly mention about it.
 13. The bidder has to keep track of any changes by viewing the addendum(s) / Corrigendum(s) issued by the Purchaser on time-to- time basis in the E-Procurement platform. The Company calling for tenders shall not be responsible for any claims/problems arising out of this.
 14. Unregistered suppliers, who are techno-commercially qualified against the open tender, are requested to register with BHEL as permanent supplier by submitting the Supplier Registration Form (SRF) in online supplier registration portal (<https://supplier.bhel.in/>).
 15. The General Conditions of Contract and the Special Conditions in each enquiry and the resulting purchase order constitute the entire contract between the parties. In case of any discrepancy between the provisions of General Conditions of Contract and Special Conditions of the Tender,

Signature Not Verified

Signed By: RAKESH
KUMAR
Location: BHEL, Goindwal
Signing Date: 05.04.2023





General Conditions of Contract (GCC) of MM Tenders
BHARAT HEAVY ELECTRICALS LIMITED

Industrial Valve Plant: 433, Industrial Complex,
Goindwal Sahib, Dist. Tarn Taran,
Punjab-143422 (INDIA)

the provisions in Special Conditions of the Tender shall prevail and interpretation of BHEL of such condition/clause will be final and binding on both the parties ..





General Conditions of Contract (GCC) of MM Tenders

BHARAT HEAVY ELECTRICALS LIMITED

Industrial Valve Plant: 433, Industrial Complex,
Goindwal Sahib, Dist. Tarn Taran,
Punjab-143422 (INDIA)

Annexure-X

BRIEF PROCEDURE FOR CONDUCT OF CONCILIATION PROCEEDINGS

1. The proceedings of Conciliation shall broadly be governed by Part-III of the Arbitration and Conciliation Act 1996 or any statutory modification thereof and as provided herein:
2. The party desirous of resorting to Conciliation shall send an invitation/notice in writing to the other party to conciliate specifying all points of Disputes with details of the amount claimed. The party concerned shall not raise any new issue thereafter. Parties shall also not claim any interest on claims/counter-claims from the date of notice invoking Conciliation till the conclusion of the Conciliation proceedings.
3. The party receiving the invitation/notice for Conciliation shall within 30 days of receipt of the notice of Conciliation intimate its consent for Conciliation along with its counter-claims, if any.
4. The Conciliation in a matter involving claim or counter-claim (whichever is higher) up to Rs 5 crores shall be carried out by sole Conciliator nominated by BHEL while in a matter involving claim or counter-claim (whichever is higher) of more than Rs 5 crores Conciliation shall be carried out by 3 Conciliators nominated by BHEL.
5. The Parties shall be represented by only their duly authorized in-house executives/officers and neither Party shall be represented by a Lawyer.
6. The first meeting of the IEC shall be convened by the IEC by sending appropriate communication/notice to both the parties as soon as possible but not later than 30 days from the date of his/their appointment. The hearings in the Conciliation proceeding shall ordinarily be concluded within two (2) months and, in exceptional cases where parties have expressed willingness to settle the matter or there exists possibility of settlement in the matter, the proceedings may be extended by the IEC by a maximum of further 2 months with the consent of the Parties subject to cogent reasons being recorded in writing.
7. The IEC shall thereafter formulate recommendations for settlement of the Disputes supported by reasons at the earliest but in any case, within 15 days from the date of conclusion of the last hearing. The recommendations so formulated along with the reasons shall be furnished by the IEC to both the Parties at the earliest but in any case, within 1 month from the date of conclusion of the last hearing.
8. Response/modifications/suggestions of the Parties on the recommendations of the IEC are to be submitted to the IEC within time limit stipulated by the IEC but not more than 15 days from the date of receipt of the recommendations from the IEC.
9. In the event, upon consideration, further review of the recommendations is considered necessary, whether by BHEL or by the other Party, then, the matter can be remitted back to the IEC with

Signature Not Verified
Signed By: RAKESH
KUMAR
Location: BHEL, Goindwal
Signing Date: 05.04.2023





General Conditions of Contract (GCC) of MM Tenders

BHARAT HEAVY ELECTRICALS LIMITED

Industrial Valve Plant: 433, Industrial Complex,
Goindwal Sahib, Dist. Tarn Taran,
Punjab-143422 (INDIA)

request to reconsider the same in light of the issues projected by either/both the Parties and to submit its recommendations thereon within the following 15 days from the date of remitting of the case by either of the Parties.

10. Upon the recommendations by the Parties, with or without modifications, as considered necessary, the IEC shall be called upon to draw up the Draft Settlement Agreement in terms of the recommendations.
11. When a consensus can be arrived at between the parties only in regard to any one or some of the issues referred for Conciliation the draft Settlement Agreement shall be accordingly formulated in regard to the said Issue(s), and the said Settlement Agreement, if signed, by the parties, shall be valid only for the said issues. As regards the balance issues not settled, the parties may seek to resolve them further as per terms and conditions provided in the contract.
12. In case no settlement can be reached between the parties, the IEC shall by a written declaration, pronounce that the Conciliation between the parties has failed and is accordingly terminated.
13. Unless the Conciliation proceedings are terminated in terms of para 22 (b), (c) & (d) herein below, the IEC shall forward his/its recommendations as to possible terms of settlement within one (1) month from the date of last hearing. The date of first hearing of Conciliation shall be the starting date for calculating the period of 2 months.
14. In case of 3 members IEC, 2 members of IEC present will constitute a valid quorum for IEC and meeting can take place to proceed in the matter after seeking consent from the member who is not available. If necessary, videoconferencing may be arranged for facilitating participation of the members. However, the IEC recommendations will be signed by all members. Where there is more than one (1) Conciliator, as a general rule they shall act jointly. In the event of differences between the Members of IEC, the decision/recommendations of the majority of the Members of IEC shall prevail and be construed as the recommendation of the IEC.
15. The Draft Settlement Agreement prepared by the IEC in terms of the consensus arrived at during the Conciliation proceedings between the Parties shall be given by the IEC to both the parties for putting up for approval of their respective Competent Authority.
16. Before submitting the draft settlement agreement to BHEL's Competent Authority viz. the Board Level Committee on Alternative Dispute Resolution (BLCADR) for approval, concurrence of the other party's Competent Authority to the draft settlement agreement shall be obtained by the other party and informed to BHEL within 15 days of receipt of the final draft settlement agreement by it. Upon approval by the Competent Authority, the Settlement Agreement would thereafter be signed by the authorized representatives of both the Parties and authenticated by the members of the IEC.
17. In case the Draft Settlement Agreement is rejected by the Competent Authority of BHEL or the other Party, the Conciliation proceedings would stand terminated.





General Conditions of Contract (GCC) of MM Tenders

BHARAT HEAVY ELECTRICALS LIMITED

Industrial Valve Plant: 433, Industrial Complex,
Goindwal Sahib, Dist. Tarn Taran,
Punjab-143422 (INDIA)

18. A Settlement Agreement shall contain a statement to the effect that each of the person(s) signing thereto (i) is fully authorized by the respective Party(ies) he/she represents, (ii) has fully understood the contents of the same and (iii) is signing on the same out of complete freewill and consent, without any pressure, undue influence.
19. The Settlement Agreement shall thereafter have the same legal status and effect as an arbitration award on agreed terms on the substance of the dispute rendered by an arbitral tribunal passed under section 30 of the Arbitration and Conciliation Act, 1996.
20. Acceptance of the Draft Settlement Agreement/recommendations of the Conciliator and/or signing of the Settlement Agreement by BHEL shall however, be subject to withdrawal/closure of any arbitral and/or judicial proceedings initiated by the concerned Party in regard to such settled issues.
21. Unless otherwise provided for in the agreement, contract or the Memorandum of Understanding, as the case may be, in the event of likelihood of prolonged absence of the Conciliator or any member of IEC, for any reason/incapacity, the Competent Authority/Head of Unit/Division/Region/Business Group of BHEL may substitute the Conciliator or such member at any stage of the proceedings. Upon appointment of the substitute Conciliator(s), such reconstituted IEC may, with the consent of the Parties, proceed with further Conciliation into the matter either de-novo or from the stage already reached by the previous IEC before the substitution.
22. The proceedings of Conciliation under this Scheme may be terminated as follows:
- On the date of signing of the Settlement agreement by the Parties; or,
 - By a written declaration of the IEC, after consultation with the parties, to the effect that further efforts at conciliation are no longer justified, on the date of the declaration; or,
 - By a written declaration of the Parties addressed to the IEC to the effect that the Conciliation proceedings are terminated, on the date of the declaration; or,
 - By a written declaration of a Party to the other Party and the IEC, if appointed, to the effect that the Conciliation proceedings are terminated, on the date of the declaration.
 - On rejection of the Draft Settlement Agreement by the Competent Authority of BHEL or the other Party.





General Conditions of Contract (GCC) of MM Tenders

BHARAT HEAVY ELECTRICALS LIMITED

Industrial Valve Plant: 433, Industrial Complex,
Goindwal Sahib, Dist. Tarn Taran,
Punjab-143422 (INDIA)

23. The Conciliator(s) shall be entitled to following fees and facilities:

Sr. No.	Particulars	Amount
1	Sitting fees	Each Member shall be paid a Lump Sum fee of Rs 75,000/- for the whole case payable in terms of paragraph No. 27 herein below.
2	Towards drafting of settlement agreement	<p>In cases involving claim and/or counter-claim of up to Rs 5crores. Rs 50,000/- (Sole Conciliator)</p> <p>In cases involving claim and/or counter-claim of exceeding Rs 5 crores but less than Rs 10 crores. Rs. 75,000 (per Conciliator)</p> <p>In cases involving claim and/or counter-claim of more than Rs 10 crores. Rs 1,00,000/- (per Conciliator)</p> <p>Note: The aforesaid fees for the drafting of the Settlement Agreement shall be paid on Signing of the Settlement Agreement after approval of the Competent Authority or Rejection of the proposed Settlement Agreement by the Competent Authority of BHEL.</p>
3	Secretarial expenses	<p>Rs 10,000/- (one time) for the whole case for Conciliation by a Sole Member IEC.</p> <p>Where Conciliation is by multi member Conciliators –Rs 30,000/- (one time)- to be paid to the IEC</p>
4	Travel and transportation and stay at outstation	As per entitlement of the equivalent officer (pay scale wise) in BHEL.
	<p>i Retired Senior Officials of other Public Sector Undertakings (pay scale wise equivalent to or more than E-8 level of BHEL)</p> <p>Others</p>	
		As per the extant entitlement of whole time Functional Directors in BHEL.

Signature Not Verified

Signed By: RAKESH

KUMAR

Location: BHEL, Goindwal

Signing Date: 05.04.2023





General Conditions of Contract (GCC) of MM Tenders BHARAT HEAVY ELECTRICALS LIMITED

Industrial Valve Plant: 433, Industrial Complex,
Goindwal Sahib, Dist. Tarn Taran,
Punjab-143422 (INDIA)

5	Venue for meeting	Unless otherwise agreed in the agreement, contract or the Memorandum of Understanding, as the case may be, the venue/seat of proceedings shall be the location of the concerned Unit / Division / Region / Business Group of BHEL. Without prejudice to the seat/venue of the Conciliation being at the location of concerned BHEL Unit / Division / Region / Business Group, the IEC after consulting the Parties may decide to hold the proceedings at any other place/venue to facilitate the proceedings. Unless, Parties agree to conduct Conciliation at BHEL premises, the venue is to be arranged by either Party alternately.
---	-------------------	--

24. The parties will bear their own costs including cost of presenting their cases/evidence/witness(es)/expert(s) on their behalf. The parties agree to rely upon documentary evidence in support of their claims and not to bring any oral evidence in IEC proceedings.

25. If any witness(es) or expert(s) is/are, with the consent of the parties, called upon to appear at the instance of the IEC in connection with the matter, then, the costs towards such witness(es)/expert(s) shall be determined by the IEC with the consent of the Parties and the cost so determined shall be borne equally by the Parties.

26. The other expenditures/costs in connection with the Conciliation proceedings as well as the IEC's fees and expenses shall be shared by the Parties equally.

27. Out of the lump sum fees of Rs 75,000/- for Sitting Fees, 50% shall be payable after the first meeting of the IEC and the remaining 50% of the Sitting Fees shall be payable only after termination of the conciliation proceedings in terms of para 22 hereinabove.

28. The travelling, transportation and stay at outstation shall be arranged by concerned Unit as per entitlements as per Serial No. 3 of the Table at para 23 above, and in case such arrangements are not made by the BHEL Unit, the same shall be reimbursed to the IEC on actuals limited to their entitlement as per Serial No. 4 of the Table at Para 23 above against supporting documents. The IEC Member(s) shall submit necessary invoice for claiming the fees/reimbursements.

29. The Parties shall keep confidential all matters relating to the conciliation proceedings. Confidentiality shall extend also to the settlement agreement, except where its disclosure is necessary for purposes of its implementation and enforcement or as required by or under a law or as per directions of a Court/Governmental authority/ regulatory body, as the case may be.

30. The Parties shall not rely upon or introduce as evidence in any further arbitral or judicial proceedings, whether or not such proceedings relate to the Disputes that is the subject of the Conciliation proceedings:

Signature Not Verified

Signed By: RAKESH

KUMAR

Location: BHEL, Goindwal

Signing Date: 05.04.2023





General Conditions of Contract (GCC) of MM Tenders

BHARAT HEAVY ELECTRICALS LIMITED

Industrial Valve Plant: 433, Industrial Complex,
Goindwal Sahib, Dist. Tarn Taran,
Punjab-143422 (INDIA)

- a. Views expressed or suggestions made by the other party in respect of a possible settlement of the Disputes;
- b. admissions made by the other party in the course of the Conciliator proceedings;
- c. proposals made by the Conciliator;
- d. The fact that the other Party had indicated his willingness to accept a proposal for settlement made by the Conciliator.

31. The Parties shall not present the Conciliator(s) as witness in any Alternative Dispute Resolution or Judicial proceedings in respect of a Disputes that is/was the subject of that particular Conciliation proceeding.

32. None of the Conciliators shall act as an arbitrator or as a representative or counsel of a Party in any arbitral or judicial proceeding in respect of a Disputes that is/was the subject of that particular Conciliation proceeding.

33. The Parties shall not initiate, during the Conciliation proceedings, any arbitral or judicial proceedings in respect of a Disputes that is the subject matter of the Conciliation proceedings except that a Party may initiate arbitral or judicial proceedings where, in his opinion, such proceedings are necessary for preserving his rights including for preventing expiry of period of limitation. Unless terminated as per the provisions of this Scheme, the Conciliation proceedings shall continue notwithstanding the commencement of the arbitral or judicial proceedings and the arbitral or judicial proceedings shall be primarily for the purpose of preserving rights including preventing expiry of period of limitation.

34. The official language of Conciliation proceedings under this Scheme shall be English unless the Parties agree to some other language.





General Conditions of Contract (GCC) of MM Tenders

BHARAT HEAVY ELECTRICALS LIMITED

Industrial Valve Plant: 433, Industrial Complex,
Goindwal Sahib, Dist. Tarn Taran,
Punjab-143422 (INDIA)

Appendix-I of Annexure-X

FORMAT FOR SEEKING CONSENT FOR REFERRING THE DISPUTES TO CONCILIATION THROUGH IEC

To,

M/s. (Stakeholder's name)

Sub: Resolution of the Disputes through conciliation by Independent Expert Committee (IEC).

Ref: Contract No/MoU/Agreement/LOI/LOA& date _____.

Sir,

With reference to above referred Contract/MoU/Agreement/LOI/LOA, you have raised certain Disputes/claims. Vide your letter dated____ you have requested BHEL to refer the Disputes/claims to IEC for Conciliation.

We are enclosing herewith Format (3) for giving consent and the terms and conditions of BHEL Conciliation Scheme, 2018 governing conciliation through IEC. You are requested to give your unconditional consent to the said terms and conditions of the Scheme by returning the same duly sealed and signed on each page. On receipt of your consent, matter will be put to the Competent Authority for consideration and decision.

Please note that BHEL has also certain claims against you (if applicable). BHEL reserves its right to agree or not to agree conciliation of the said disputes through BHEL and this letter is being issued without prejudice to BHEL's rights and contentions available under the contract and law.

Yours faithfully,

Representative of BHEL





General Conditions of Contract (GCC) of MM Tenders

BHARAT HEAVY ELECTRICALS LIMITED

Industrial Valve Plant: 433, Industrial Complex,
Goindwal Sahib, Dist. Tarn Taran,
Punjab-143422 (INDIA)

Appendix-II of Annexure-X

FORMAT FOR GIVING CONSENT BY CONTRACTOR/VENDOR/CUSTOMER/COLLABORATOR/CONSORTIUM PARTNERS FOR REFERRING THE DISPUTES TO CONCILIATION THROUGH IEC

To,

BHEL

.....

Sub: Resolution of Disputes through Conciliation by Independent Expert Committee (IEC).

Ref: Contract/MoU/Agreement/LOI/LOA No

& date ____

With reference to above referred contract, our following bills/invoices/claims submitted to BHEL are still unpaid giving rise to Disputes:

SL. no.	Claim Description	Bill submitted to BHEL (no. and date)	Amount of the bill/claim	Amount received from BHEL	Outstanding Amount

Accordingly, we request you to kindly refer the Disputes in respect of above claims to IEC for Conciliation.

We hereby agree and give our unconditional consent to the terms and conditions of BHEL Conciliation Scheme, 2018 governing conciliation through IEC. We have signed the same on each page and enclosed it for your consideration.

Yours faithfully,

(Signature with stamp)

**Authorized Representative of Contractor
Name, with designation Date**





General Conditions of Contract (GCC) of MM Tenders

BHARAT HEAVY ELECTRICALS LIMITED

Industrial Valve Plant: 433, Industrial Complex,
Goindwal Sahib, Dist. Tarn Taran,
Punjab-143422 (INDIA)

Appendix-III of Annexure-X

STATEMENT OF CLAIMS/COUNTER CLAIMS TO BE SUBMITTED TO THE IEC BY BOTH THE PARTIES

1. Chronology of the Disputes
2. Brief of the Contract/MoU/Agreement/LOI/LOA
3. Brief history of the Disputes:
4. Issues:
5. Details of Claim(s)/Counter Claim(s):

Sl. No.	Description of claim(s)/Counter Claim	Amount (in INR) Or currency applicable in the contract	Relevant contract clause

6. Basis/Ground of claim(s)/counter claim(s) (along with relevant clause of contract)

Note– The Statement of Claims/Counter Claims may ideally be restricted to maximum limit of 20 pages. Relevant documents may be compiled and submitted along with the statement of Claims/Counter Claims. The statement of Claims/Counter Claims is to be submitted to all IEC members and to the other party by post as well as by email.



Tender Enquiry No. 2324-028E Dated 10.07.2023 Due date 21.07.2023

Tender Description: Supply of Fasteners GVFST

(Annexure - P)

Pre-Qualification Criteria – As per Tender Special Term S2.2						
S.N.	Executed order value (Net of Taxes) as per bidder (INR)	Purchase order no. and date [PO date should be on or after 01.07.2020 till bid opening date]	Purchase Order issued by (Client name) M/s	Item description as per PO	Documents submitted against completion /execution proof of the afore mentioned PO (Invoice / Consignee Receipt Note / Completion Certificate) [Document date should be on or after 01.07.2020 till bid opening date]	Full address of the client and contact person (Name & Details i.e. Mail ID, Mobile No. etc)
1						
2						
3						
4						
5						
6						
7						

More lines can be added, if required.

Notes :-

1. Kindly attach all the above stated documents in the Quotation.
2. All proof of execution like Invoice / Consignee Receipt Note / Completion Certificate must include the Purchase Order reference number, otherwise that PO will not be considered for the fulfilment of this tender term.

SL. No.	DRAWING No.	MATERIAL CODE	MATL. SPECN	THREAD SIZE	L	ød	b	k	S		e		r	FINISH Wt. (kg)	MATL. MARK	SIZE/RATING
									MAX	MIN	MAX	MIN				
01	3-V-N073-06881/04	96 456 260 0000	ASTM A193-B7, HT9 CERTIFY	1/2"-13UNC-2A	55	12.7	30	9	22.22	21.59	25.65	24.61	0.75	0.06	B7	2"150, 2"300 3"150, 3"300
02	3-V-N033-06881/04	96 456 261 0000		5/8"-11UNC-2A	60	15.875	38	10.7	26.97	26.19	31.17	29.85	1	0.10	B7	4"150, 4"300
03	3-V-N001-06881/04	96 456 262 0000		5/8"-11UNC-2A	70	15.875	38	10.7	26.97	26.19	31.17	29.85	1	0.14	B7	6", 8", 10", 12"/150 6", 8", 10"/300
04	3-V-N224-06881/03	96 456 231 0000		5/8"-11UNC-2A	80	15.875	38	10.7	26.97	26.19	31.17	29.85	1	0.16	B7	20"/150
05	3-V-C329-06881/03	96 456 433 0000		5/8"-11UNC-2A	75	15.875	38	10.7	26.97	26.19	31.17	29.85	1	0.15	B7	4"-C900
06	3-V-N204-06881/03	96 456 450 0000	SA307 Gy. B CERTIFY	3/4"-10UNC-2A	85	19.05	30	12.7	31.75	30.78	36.65	35.10	1	0.27	307-B	6"-C150
07	3-V-N205-06881/03	96 456 451 0000		3/4"-10UNC-2A	90	19.05	35	12.7	31.75	30.78	36.65	35.10	1	0.28	307-B	8"-C150
08	3-V-N207-06881/03	96 456 452 0000		7/8"-9UNC-2A	105	22.225	40	14.7	36.52	35.41	42.16	40.31	1	0.43	307-B	10" & 12"-C150

CAUTION: The information on this is the property of BHARAT HEAVY ELECTRICALS LIMITED. It must not be used directly or indirectly in any way detrimental to the interest of the company.

REV	DATE	ALTD:-
		CHE&APPD

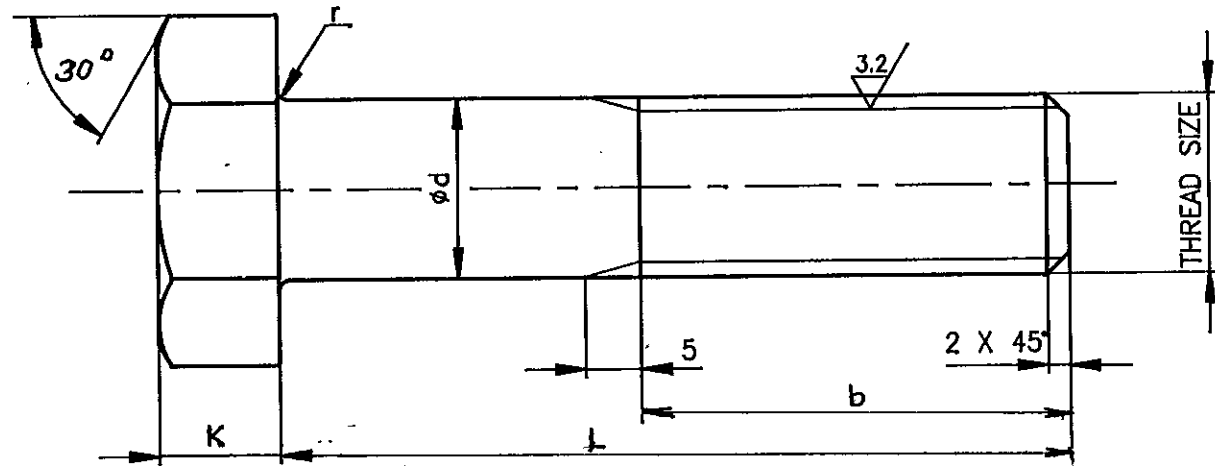

19 12.5/3.2

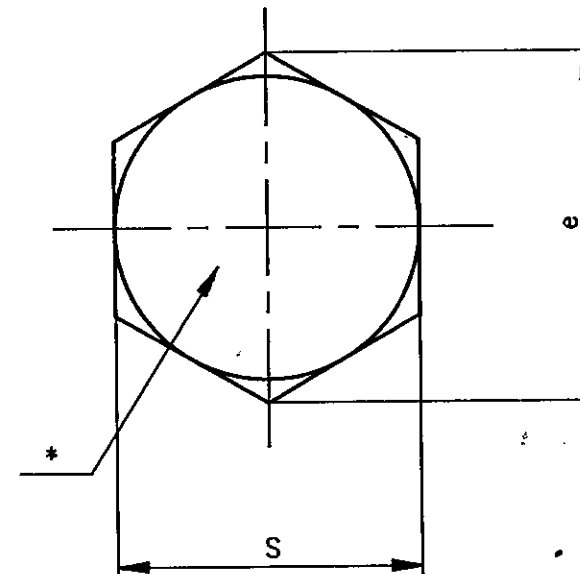

NOTES:-

- * PUNCH MATERIAL MARK.
- FOR QUALITY REQUIREMENTS REFER LATEST APPLICABLE TDC 5:164
- ~~THIS COMPONENTS SHOULD BE GALVANISED TO A DEPTH OF 8 TO 12 MICRONS~~

RETRACED WITH REV.07 ON 11.6.99

REV.	DATE	ALTD:-
		CHKD: S APPD
REV.	DATE	ALTD:-
		CHD&APPD
REV.	DATE	ALTD:-
07	11.6.99	CHE&APPD, M.R.K W

GALVANISING (NOTE 3) ELIMINATED.
DCN No. HM.0393

SL No	DESCRIPTION	MATL CODE	MATL SPECN	HEAT TREATMENT	SCRAP SORT	NET WT (kg)	GROSS WT (kg)	DRAWING No	ITEM No

BHARAT HEAVY ELECTRICALS LTD., BOILER PLANT UNIT, TIRUCHIRAPALLI-620 014.				NAME	SIGN	DATE
DRAWN	R.L					11.6.99
CHECKED						
APPROVED	M.R.K.					11/06/99

DEPT. VL	GRADE OF UNTOI DIM	FIRST ANGLE	SCALE	WEIGHT (kg)	ITEM No
340	E/M/T		NTS	REFERTABLE	

TITLE: **HEX. BOLT** DRG No: **3-V-0000-06881** REVISION: **07**

9/890-0000-Λ-Σ
DRAWING NO.

SL. No.	DRAWING No.	COMP. CODE	MATL. SPECN.	S		e		m		øD	MATL. MARK	NET WT. (Kg.)
				MAX.	MIN.	MAX.	MIN.	MAX.	MIN.			
01	3.V.N073.06876/03	96 456 279	ASTM A194 - 2H, CERTIFY	22.22	21.59	25.65	24.61	12.80	11.79	1/2"-13 UNC -2B	2H	0.02
02	3.V.N025.06876/03	96 456 280		26.97	26.19	31.17	29.85	16.03	14.91	5/8"-11 UNC -2B	2H	0.03
03	3.V.N057.06876/03	96 456 281		31.75	30.78	36.65	35.10	19.25	18.03	3/4"-10 UNC -2B	2H	0.08
04	3.V.N065.06876/03	96 456 282		41.28	40.01	47.65	45.62	25.70	24.28	1"-8 UNC -2B	2H	0.17
05	3.V.N105.06876/03	96 456 283		46.02	44.60	53.16	50.85	29.93	27.41	1.1/8"-8 UN -2B	2H	0.27
06	3.V.N206.06876/02	96 456 431		36.52	35.41	42.16	40.37	22.47	21.16	7/8"-9 UNC -2B	2H	0.11
07	3.V.N204.06876/02	96 456 453	SA 307 Gr.B CERTIFY	31.75	30.78	36.65	35.10	19.25	18.03	3/4"-10 UNC -2B	307 B	0.08
08	3.V.N207.06876/02	96 456 454		36.52	35.41	42.16	40.37	22.47	21.16	7/8"-9 UNC -2B	307 B	0.11
09	3.V.F505.06876/01	96 456 683	ASTM A194 - 2H, CERTIFY	50.8	49.23	58.65	56.11	31.78	30.15	1.1/4"-8 UN -2B	2H	0.22
10	3.V.N848.06876	96 453 667		55.57	53.8	64.16	61.37	35.0	33.27	1.3/8"-8 UN -2B	2H	0.42
11	3.V.N827.06876	96 453 668		60.33	58.42	69.65	66.59	38.23	36.40	1.1/2"-8 UN -2B	2H	0.52
12	3.V.N846.06876/01	96 453 669		69.85	67.61	80.65	77.09	44.68	42.65	1.3/4"-8 UN -2B	2H	0.81
13	3.V.NK44.06876	96 465 904		65.07	63.02	75.15	71.84	41.45	39.53	1.5/8"-8 UN -2B	2H	0.68
14	3.V.NK45.06876	96 465 906		79.37	76.84	91.64	87.61	51.13	48.90	2"-8 UN -2B	2H	1.36

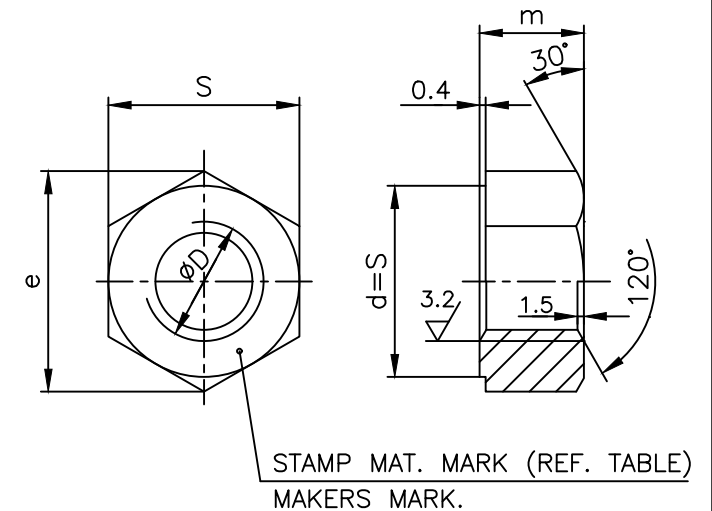

RETRACED WITH REV. 09 ON 26.11.18

NOTE:

1. FOR QUALITY REQUIREMENTS REFER LATEST APPLICABLE STANDARD(TDC:5:164).

NO OFF	DESCRIPTION	MATL CODE	MATL SPECN	HEAT TREATMENT	SCRAP SORT	NET WT (kg)	GROSS WT (kg)	DRAWING No	ITEM No
-	-	-	-	-	-	-	-	-	-

CAUTION: The information on this document is the property of BHARAT HEAVY ELECTRICALS LTD. It must not be used directly or indirectly in any way detrimental to the interest of the company.

TYPE OF PRODUCT OR NAME OF CUSTOMER/PROJECT

BHARAT HEAVY ELECTRICALS LTD.,
UNIT: HIGH PRESSURE BOILER PLANT.
TIRUCHIRAPALLI-620014.

DRN	M.SRINIVASAN	SIGN	DATE	NO.OF VAR.
CHD	N.DHANAPAL		22.04.96	
APPD	A.VISWANATHAN		22.04.96	

DEPT VL
CODE 320

SCALE NTS

WEIGHT (KG). REF. TABLE

REFERENCE INFORMATION CAD: C306876

TITLE HEX NUT

CARD CODE U 01

DRAWING NO. 3-V-0000-06876

NO. OF ITEMS

REV 09

REV	DATE	ALTERED	R.P.SINGH
09	26.11.18	CHD & APPD SSK & KRS	
		SL. No.13 & 14 INCLUDED.	

ALL DIMENSIONS ARE IN MILLIMETRES. FOR TOLERANCES OF UNTOLERANCED DIMENSIONS DURING MANUFACTURE REFER RELEVANT QCP / QP.

DRAWING NO. 6ZL0Z-0000-A-3									
SL No.	DRAWING No.	COMP. CODE	MATL. SPECN.	DIMENSIONS				WT(KG)	
				MDxP-6g	L	K			
01	3-V-0001-20729/02	964524410000	A193 B7, CERTIFY	M30x3	185	3		1.03	
02	3-V-0002-20729/02	964524420000		M30x3	280	3		1.55	
03	3-V-0003-20729/02	964524430000		M42x3	440	3		4.79	
04	3-V-0004-20729/02	964524440000		M48x3	520	3		7.39	
05	3-V-0005-20729/02	964526850000		M20x2.5	195	2.5		0.48	
06	3-V-0006-20729/02	964527050000		M30x3	270	3		1.49	
07	3-V-0007-20729/02	964527260000		M36x3	270	3		2.04	
08	3-V-0008-20729/02	964527270000		M36x3	500	3		3.78	
09	3-V-0009-20729/02	964527280000		M36x3	310	3		2.34	
10	3-V-0010-20729/02	964527290000		M20x2.5	165	2.5		0.52	
11	3-V-0011-20729/02	964527300000		M22x2.5	180	2.5		0.54	
12	3-V-0012-20729/02	964527310000		M24x3	190	3		0.68	
13	3-V-0013-20729/02	964527320000		M24x3	210	3		0.75	
14	3-V-0014-20729/02	964527330000		M24x3	250	3		0.89	
15	3-V-0015-20729/01	964534230000		M12x1.75	90	2		0.09	
16	3-V-0016-20729/01	964534240000		M16x2	125	2		0.20	
17	3-V-0017-20729/01	964534250000		M20x2.5	150	2.5		0.47	
18	3-V-0018-20729	964651670000		M42x3	220	3		2.4	
19	3-V-0019-20729	964660060000		M39x3	480	3		4.5	
20	3-V-0020-20729	964653440000		M39x3	240	3		2.2	
21	3-V-0021-20729	964653450000		M39x3	280	3		2.6	
22	3-V-0022-20729	964654080000		M42x3	340	3		3.5	
23	3-V-0023-20729	964655060000		M48x3	300	3		4.20	
24	3-V-0024-20729	964654870000		M30	240	3		1.3	
25	3-V-0025-20729	964655080000		M33	220	3.5		1.5	

SL No.	DRAWING No.	COMP. CODE	MATL. SPECN.	DIMENSIONS			WT(KG)
				MDxP-6g	L	K	
26	3-V-0026-20729/02	964524450000	A193 B16, CERTIFY	M30x3	185	3	1.03
27	3-V-0027-20729/02	964524460000		M30x3	280	3	1.55
28	3-V-0028-20729/02	964524470000		M42x3	440	3	4.79
29	3-V-0029-20729/02	964524480000		M48x3	520	3	7.39
30	3-V-0030-20729/02	964526860000		M20x2.5	195	2.5	0.48
31	3-V-0031-20729/02	964527060000		M30x3	270	3	1.49
32	3-V-0032-20729/02	964527340000		M36x3	270	3	2.04
33	3-V-0033-20729/02	964527350000		M36x3	500	3	3.78
34	3-V-0034-20729/02	964527360000		M36x3	310	3	2.34
35	3-V-0035-20729/02	964527370000		M20x2.5	165	2.5	0.52
36	3-V-0036-20729/02	964527380000		M22x2.5	180	2.5	0.54
37	3-V-0037-20729/02	964527390000		M24x3	190	3	0.68
38	3-V-0038-20729/02	964527400000		M24x3	210	3	0.75
39	3-V-0039-20729/02	964527410000		M24x3	250	3	0.89
40	3-V-0040-20729/01	964534260000		M12x1.75	90	2	0.09
41	3-V-0041-20729/01	964534270000		M16x2	125	2	0.20
42	3-V-0042-20729/01	964534280000		M20x2.5	150	2.5	0.47
43	3-V-0043-20729	964651700000		M42x3	220	3	2.4
44	3-V-0044-20729	964660070000		M39x3	480	3	4.5
45	3-V-0045-20729	964652610000		M39x3	240	3	2.2
46	3-V-0046-20729	964652620000		M39x3	280	3	2.6
47	3-V-0047-20729	964654090000		M42x3	340	3	3.5
48	3-V-0048-20729	964654150000		M27x3	180	3	0.8
49	3-V-0049-20729	964655740000		M33	220	3.5	1.5

12.5 / 3.2

NOTES:-

1. QUALITY REQUIREMENTS SHALL BE AS PER LATEST APPLICABLE QUALITY WORK INSTRUCTION.
- * 2. PUNCH MATL.MARK B7 FOR A193-B7 AND B16 FOR A193-B16

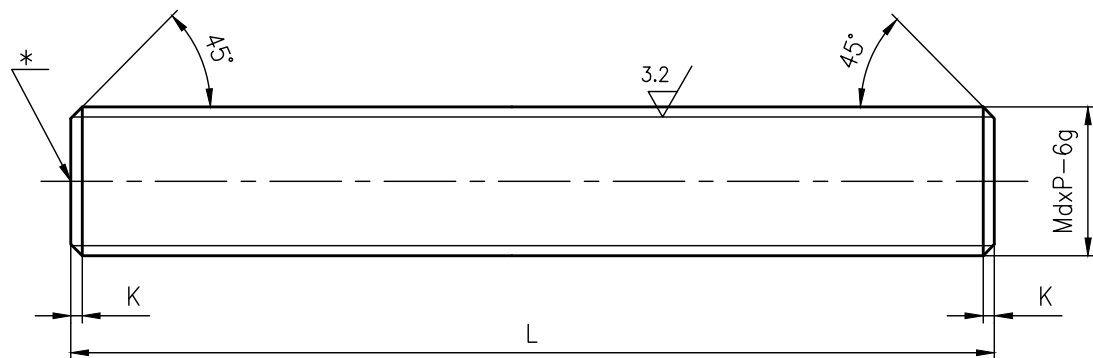

REV	DATE	ALTERED	GANESH	REV	DATE	ALTERED	GANESH
13	28.05.13	CHD & APPDK	RAJASEKARAN	12	14.03.13	CHD & APPD	M.RAJAKUMAR
		SL. No. 49 INCLUDED.				SL. No. 25 INCLUDED.	

CAUTION: The information on this document is the property of BHARAT HEAVY ELECTRICALS LTD. It must not be used directly or indirectly in any way detrimental to the interest of the company.

NO OFF	DESCRIPTION	MATL CODE	MATL SPECN	HEAT TREATMENT	SCRAP SORT	NET WT (kg)	GROSS WT (kg)	DRAWING No	ITEM No
	TYPE OF PRODUCT OR NAME OF CUSTOMER/PROJECT								
	BHARAT HEAVY ELECTRICALS LTD., UNIT: HIGH PRESSURE BOILER PLANT. TIRUCHIRAPALLI-620014.	DRN	V.BAIRAVAN	SIGN		DATE	15.3.04	NO.OF VAR.	
		CHD	K.RAJASEKARAN			DATE	15.3.04		
		APPD	M.RAJAKUMAR			DATE	15.3.04		
DEPT	VL	SCALE	WEIGHT (KG).	REFERENCE INFORMATION			NO. OF ITEMS		
CODE	320	NTS	REF. TABLE	CAD REF:-T320729					
TITLE			CARD CODE	DRAWING NO.		REV			
STUD			U 01	3-V-0000-20729		13			

ALL DIMENSIONS ARE IN MILLIMETRES. FOR TOLERANCES OF UNTOLERANCED DIMENSIONS DURING MANUFACTURE REFER RELEVANT QCP / QP.

3-V-0000-20717
DRAWING NO.

12.5 / 3.2

SL. NO.	DRAWING NO.	MATL. SPECN.	COMP.CODE	DIMENSIONS						FINISHED WT(kg)
				Md	P	H	B	C	øD	
01.	3-V-0001-20717	A194-2H, CERTIFY	96 452 160 0000	M22	2.5	18	32	37	31	0.07
02.	3-V-0002-20717		96 452 161 0000	M30	3	24	46	53.1	44	0.21
03.	3-V-0003-20717		96 452 312 0000	M42	3	42	65	75	62	0.29
04.	3-V-0004-20717/1		96 452 450 0000	M39	4	32	60 [△]	65	55	0.24
05.	3-V-0005-20717		96 452 688 0000	M5	0.8	4	8.3	9.2	7	0.01
06.	3-V-0006-20717		96 452 932 0000	M48	3	48	75	86.5	72	0.94
07.	3-V-0007-20717		96 453 057 0000	M52	3	52	80	92.4	77	1.2
08.	3-V-0008-20717		96 460 645 0000	M30	3	30	46	53.1	44	0.23
17.	3-V-0017-20717		96 453 358 0000	M22	2.5	22	32	37	31	0.09
18.	3-V-0018-20717/1		96 466 008 0000	M39	3	39	60 [△]	65	55	0.29
20.	3-V-3234-20717		96 465 274 0000	M33	3.5	33	50	57.7	49	0.32

SL. NO.	DRAWING NO.	MATL. SPECN.	COMP.CODE	DIMENSIONS						FINISHED WT(kg)
				Md	P	H	B	C	øD	
09.	3-V-0009-20717/1	A194-Gr.7, CERTIFY	96 452 309 0000	M22	2.5	18	32	37	31	0.07
10.	3-V-0010-20717/1		96 452 310 0000	M30	3	24	46	53.1	44	0.21
11.	3-V-0011-20717/1		96 452 311 0000	M42	3	42	65	75	62	0.29
12.	3-V-0012-20717/1		96 453 058 0000	M52	3	52	80	92.4	77	1.2
13.	3-V-0013-20717/1		96 460 647 0000	M30	3	30	46	53.1	44	0.23
14.	3-V-0014-20717/2		96 453 203 0000	M39	4	32	60 [△]	65	55	0.24
15.	3-V-L793-20717/1		96 460 741 0000	M42	4.5	42	65	75	62	0.29
16.	3-V-0016-20717/1		96 453 357 0000	M22	2.5	22	32	37	31	0.09
19.	3-V-0019-20717/1		96 466 009 0000	M39	3	39	60 [△]	65	55	0.29
21.	3-V-3237-20717		96 465 275 0000	M33	3.5	33	50	57.7	49	0.32

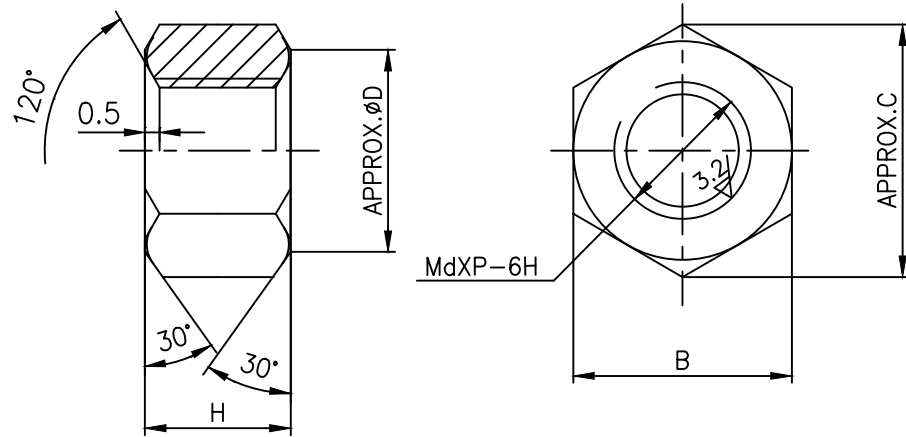

NOTES:-

- 01. LATEST APPLICABLE QUALITY WORK INSTRUCTION SHALL BE FOLLOWED IN ALL RESPECTS.

NO OFF	DESCRIPTION	MATL CODE	MATL SPECN	HEAT TREATMENT	SCRAP SORT	NET WT (kg)	GROSS WT (kg)	DRAWING No	ITEM No
-	-	-	-	-	-	-	-	-	-
TYPE OF PRODUCT OR NAME OF CUSTOMER/PROJECT									
BHARAT HEAVY ELECTRICALS LTD., UNIT: HIGH PRESSURE BOILER PLANT. TIRUCHIRAPALLI-620014.					DRN	NAME	SIGN	DATE	NO.OF VAR.
					CHD	K.RAJASEKARAN		17.3.07	
					APPD	M.RAJAKUMAR		17.3.07	
DEPT VL	SCALE	WEIGHT (KG).	REFERENCE INFORMATION			NO. OF ITEMS			
CODE 320	N T S		CAD REF: T320717 PT40						
TITLE					CARD CODE	DRAWING NO.			REV
NUT					U 01	3-V-0000-20717			06

REV	DATE	ALTERED	R.P.SINGH	REV	DATE	ALTERED	M.SRINIVASAN
06	04.11.17	CHD & APPD	SSK & KRS	05	10.05.08	CHD & APPD	K.S.RAMAN
DIMENSIONS 60 WAS 56 FOR M39				SL.NO. 20 & 21 INCLUDED.			
DCP NO.802298							

CAUTION: The information on this document is the property of BHARAT HEAVY ELECTRICALS LTD. It must not be used directly or indirectly in any way detrimental to the interest of the company.

DRAWING NO: 3-V-0000-23248

12.5 / 3.2

SL.No	DRAWING No.	MATERIAL	MATL. CODE	SIZE	L	WEIGHT IN Kgs.	MATL. MARK*
01	3-V-F522-23248/01	ASTM A193 Gr. B16	96 456 882 0000	7/8"-9UNC-2A	150	0.45	B16
02	3-V-F523-23248/01		96 456 883 0000	3/4"-10UNC-2A	133	0.30	B16
03	3-V-F524-23248/01		96 456 884 0000	1"-8UNC-2A	170	0.71	B16
04	3-V-F525-23248/01		96 456 885 0000	1.1/4"-8UN-2A	215	1.34	B16
05	3-V-F526-23248/01		96 456 886 0000	1.1/8"-8UN-2A	220	1.41	B16
06	3-V-F527-23248/02		96 456 887 0000	1.1/4"-8UN-2A	250	1.74	B16
07	3-V-0001-23248/01	ASTM A193-B8M CL.2, CERTIFY	96 465 635 0000	1/2"-13UNC-2A	80	0.08	B8M
08	3-V-0002-23248/01		96 465 636 0000	5/8"-11UNC-2A	86	0.13	B8M
09	3-V-0003-23248/01		96 465 637 0000	5/8"-11UNC-2A	105	0.16	B8M
10	3-V-0004-23248/01		96 465 638 0000	5/8"-11UNC-2A	118	0.18	B8M
11	3-V-0005-23248/01		96 465 639 0000	3/4"-10UNC-2A	120	0.26	B8M
12	3-V-0006-23248/01		96 465 640 0000	3/4"-10UNC-2A	133	0.29	B8M
13	3-V-0007-23248/01		96 465 641 0000	7/8"-9UNC-2A	150	0.45	B8M
14	3-V-0008-23248/01		96 465 642 0000	1"-8UNC-2A	135	0.53	B8M
15	3-V-0009-23248/01		96 465 643 0000	1"-8UNC-2A	158	0.62	B8M
16	3-V-0010-23248/01		96 465 644 0000	1"-8UNC-2A	170	0.67	B8M
17	3-V-0011-23248/01		96 465 645 0000	1.1/8"-8UN-2A	180	0.90	B8M
18	3-V-0012-23248/01		96 465 646 0000	1.1/4"-8UN-2A	215	1.32	B8M
19	3-V-0013-23248/01		96 465 647 0000	1.1/4"-8UN-2A	250	1.54	B8M
20	3-V-0014-23248/01		96 465 769 0000	7/8"-9UNC-2A	120	0.36	B8M
21	3-V-0016-23248/01		96 465 830 0000	1.1/8"-8UN-2A	140	0.87	B8M
22	3-V-0015-23248		96 465 794 0000	1/2"-13UNC-2A	95	0.09	B8M
23	3-V-F933-23248		96 465 938 0000	1.1/8"-8UN-2A	220	1.41	B8M

SL.No	DRAWING No.	MATERIAL	MATL. CODE	SIZE	L	WEIGHT IN Kgs.	MATL. MARK*	
24	3-V-0017-23248	ASTM A193 Gr. B7M	96 465 854 0000	1/2"-13UNC-2A	80	0.08	B7M	
25	3-V-0018-23248		96 465 855 0000	5/8"-11UNC-2A	86	0.13	B7M	
26	3-V-0019-23248		96 465 856 0000	5/8"-11UNC-2A	105	0.16	B7M	
27	3-V-0020-23248		96 465 857 0000	5/8"-11UNC-2A	118	0.18	B7M	
28	3-V-0021-23248		96 465 858 0000	3/4"-10UNC-2A	120	0.26	B7M	
29	3-V-0022-23248		96 465 859 0000	3/4"-10UNC-2A	133	0.29	B7M	
30	3-V-0023-23248		96 465 860 0000	7/8"-9UNC-2A	150	0.45	B7M	
31	3-V-0024-23248		96 465 861 0000	1"-8UNC-2A	135	0.53	B7M	
32	3-V-0025-23248		96 465 862 0000	1"-8UNC-2A	158	0.62	B7M	
33	3-V-0026-23248		96 465 863 0000	1"-8UNC-2A	170	0.67	B7M	
34	3-V-0027-23248		96 465 864 0000	1.1/8"-8UN-2A	180	0.90	B7M	
35	3-V-0028-23248		96 465 865 0000	1.1/4"-8UN-2A	215	1.32	B7M	
36	3-V-0029-23248		96 465 866 0000	1.1/4"-8UN-2A	250	1.54	B7M	
37	3-V-0030-23248		96 465 867 0000	7/8"-9UNC-2A	120	0.36	B7M	
38	3-V-0031-23248		96 465 868 0000	1.1/8"-8UN-2A	140	0.87	B7M	
39	3-V-NL92-23248		ASTM A193 Gr. B8M CL.2, CERTIFY	96 473 027 0000	1.1/4"-8UN-2A	150	0.94	B8M
40	3-V-Z135-23248			96 473 028 0000	1.1/4"-8UN-2A	180	1.11	B8M

NOTE

01. FOR QUALITY REQUIREMENTS: REFER LATEST APPLICABLE PROCEDURE.

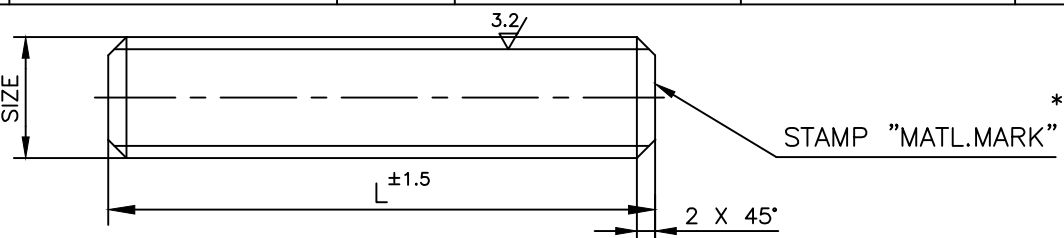

DCP No.	ALTD: TS	APPD: SSK	DCP No.	ALTD: RPS	APPD: SSK
-	CHD: RPS	DT: 07.09.22	-	CHD: SAB	DT: 22.02.21
REV 09	SL. No. 39 & 40 INCLUDED.			REV 08	3-V-F933-23248 INCLUDED.
ZONE -				ZONE -	

NO OFF	DESCRIPTION	MATL CODE	MATL SPECN	HEAT TREATMENT	SCRAP SORT	NET WT (kg)	GROSS WT (kg)	DRAWING No.	ITEM No
-	-	-	-	-	-	-	-	-	-

TYPE OF PRODUCT OR NAME OF CUSTOMER/PROJECT
REDRAWN WITH REV.5 ON 26.03.18

 BHARAT HEAVY ELECTRICALS LTD., UNIT: HIGH PRESSURE BOILER PLANT. TIRUCHIRAPALLI-620014. 365-191 02.03.2021	DRN	NAME	SIGN	DATE	NO. OF VAR.
	CHD	K.S.RAMAN		18.05.98	-
	APPD	N.NAGARAJAN		18.05.98	-

DEPT VL	SCALE NTS	WEIGHT (KG) REF.TABLE	REFERENCE INFORMATION B16 & B7M	NO. OF ITEMS -
CODE 320			CAD :C323248	
TITLE STUD	CARD CODE U 01	DRAWING NO. 3-V-0000-23248	REV 09	

DRAWING NO. 3-V-0000-23249

SL. No.	DRAWING No.	COMP. CODE	MATL. SPECN.	S		e		m		øD	MATL. MARK	NET WT. (Kg.)
				MAX.	MIN.	MAX.	MIN.	MAX.	MIN.			
01	3-V-F522-23249/02	96 456 888 0000	ASTM A194 - Gr.7	36.52	35.41	42.16	40.37	22.47	21.16	7/8"-9 UNC -2B	GR.7	0.11
02	3-V-F523-23249/02	96 456 889 0000	ASTM A194 - Gr.7	31.75	30.78	36.65	35.10	19.25	18.03	3/4"-10 UNC -2B	GR.7	0.08
03	3-V-F524-23249/02	96 456 890 0000	ASTM A194 - Gr.7	41.28	40.01	47.65	45.62	25.70	24.28	1"-8 UNC -2B	GR.7	0.17
04	3-V-F525-23249/02	96 456 891 0000	ASTM A194 - Gr.7	50.80	49.23	58.65	56.11	31.78	30.15	1.1/4"-8 UN -2B	GR.7	0.27
05	3-V-F526-23249/02	96 456 892 0000	ASTM A194 - Gr.7	46.02	44.60	53.16	50.85	29.93	27.41	1.1/8"-8 UN -2B	GR.7	0.22
06	3-V-0001-23249	96 465 648 0000	ASTM A194 - Gr.8M	22.22	21.59	25.65	24.61	12.80	11.79	1/2"-13 UNC -2B	GR.8M	0.02
07	3-V-0002-23249	96 465 649 0000	ASTM A194 - Gr.8M	26.97	26.19	31.17	29.85	16.03	14.91	5/8"-11 UNC -2B	GR.8M	0.03
08	3-V-0003-23249	96 465 650 0000	ASTM A194 - Gr.8M	31.75	30.78	36.65	35.10	19.25	18.03	3/4"-10 UNC -2B	GR.8M	0.08
09	3-V-0004-23249	96 465 651 0000	ASTM A194 - Gr.8M	36.52	35.41	42.16	40.37	22.47	21.16	7/8"-9 UNC -2B	GR.8M	0.11
10	3-V-0005-23249	96 465 652 0000	ASTM A194 - Gr.8M	41.28	40.01	47.65	45.62	25.70	24.28	1"-8 UNC -2B	GR.8M	0.17
11	3-V-0006-23249	96 465 653 0000	ASTM A194 - Gr.8M	46.02	44.60	53.16	50.85	29.93	27.41	1.1/8"-8 UN -2B	GR.8M	0.22
12	3-V-0007-23249	96 465 654 0000	ASTM A194 - Gr.8M	50.80	49.23	58.65	56.11	31.78	30.15	1.1/4"-8 UN -2B	GR.8M	0.27
13	3-V-0008-23249	96 465 847 0000	ASTM A194 - Gr.2HM	22.22	21.59	25.65	24.61	12.80	11.79	1/2"-13 UNC -2B	GR.2HM	0.02
14	3-V-0009-23249	96 465 848 0000	ASTM A194 - Gr.2HM	26.97	26.19	31.17	29.85	16.03	14.91	5/8"-11 UNC -2B	GR.2HM	0.03
15	3-V-0010-23249	96 465 849 0000	ASTM A194 - Gr.2HM	31.75	30.78	36.65	35.10	19.25	18.03	3/4"-10 UNC -2B	GR.2HM	0.08
16	3-V-0011-23249	96 465 850 0000	ASTM A194 - Gr.2HM	36.52	35.41	42.16	40.37	22.47	21.16	7/8"-9 UNC -2B	GR.2HM	0.11
17	3-V-0012-23249	96 465 851 0000	ASTM A194 - Gr.2HM	41.28	40.01	47.65	45.62	25.70	24.28	1"-8 UNC -2B	GR.2HM	0.17
18	3-V-0013-23249	96 465 852 0000	ASTM A194 - Gr.2HM	46.02	44.60	53.16	50.85	29.93	27.41	1.1/8"-8 UN -2B	GR.2HM	0.22
19	3-V-0014-23249	96 465 853 0000	ASTM A194 - Gr.2HM	50.80	49.23	58.65	56.11	31.78	30.15	1.1/4"-8 UN -2B	GR.2HM	0.27
20	3-V-0015-23249	96 465 940 0000	ASTM A194 - Gr.8M	55.57	53.8	64.16	61.37	35.0	33.27	1.3/8"-8 UN -2B	GR.8M	0.42

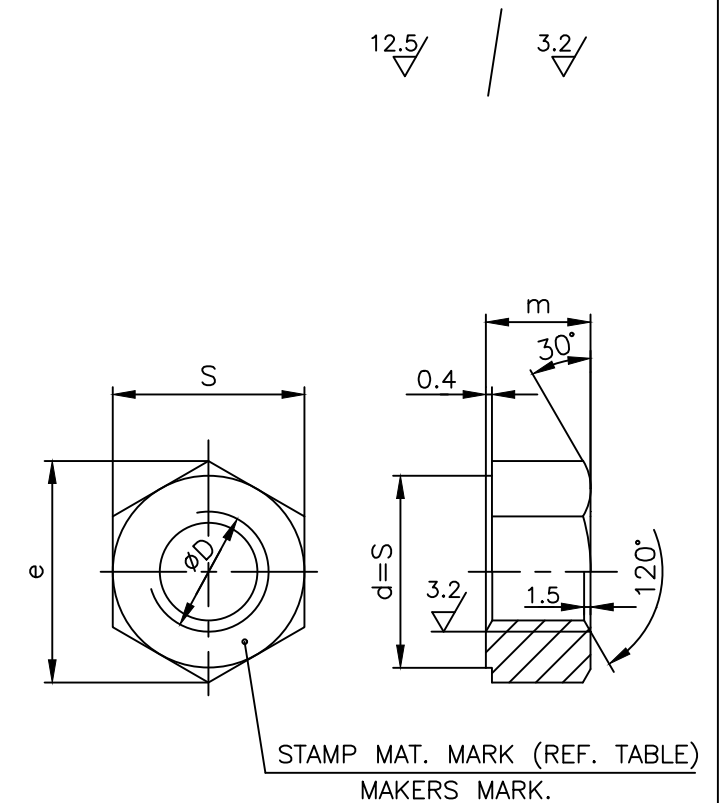

NOTE:

- FOR QUALITY REQUIREMENTS REFER LATEST APPLICABLE QUALITY PROCEDURE.
- SUITABLE OIL PRESERVATIVE SHALL BE APPLIED.

-	-	-	-	-	-	-	-	-	-	-
NO OFF	DESCRIPTION	MATL CODE	MATL SPECN	HEAT TREATMENT	SCRAP SORT	NET WT (kg)	GROSS WT (kg)	DRAWING No	ITEM No	

CAUTION: The information on this document is the property of BHARAT HEAVY ELECTRICALS LTD. It must not be used directly or indirectly in any way detrimental to the interest of the company.

TYPE OF PRODUCT OR NAME OF CUSTOMER/PROJECT

BHARAT HEAVY ELECTRICALS LTD.,
UNIT: HIGH PRESSURE BOILER PLANT.
TIRUCHIRAPALLI-620014.

DRN	M.SRINIVASAN	SIGN	DATE	NO.OF VAR.
CHD	N.DHANAPAL		23.04.96	
APPD	A.VISWANATHAN		23.04.96	

DEPT VL 365-121

SCALE NTS

WEIGHT (KG) REF. TABLE

REFERENCE INFORMATION CAD: F323249

TITLE **HEX NUT**

CARD CODE U 01

DRAWING NO. **3-V-0000-23249**

REV **05**

REV	DATE	ALTERED	R.P.SINGH
05	03.03.21	CHD & APPD	SAMEER & SSK

SL. No. 20 INCLUDED.

SL. No.	DRAWING No.	MATERIAL DETAILS					DIMENSIONS							NET Wt. (kg)	COMP. CODE	SL. No.	
		SPECN.	SIZE	CODE	HEAT TREATMENT	SCRAP SORT	GROSS WT. (kg)	L	L ₁	L ₂ ^{+17/17}	X	C	M _d				1713
1	3.V.1134.03661/1	ASTM A193-B7, CERTIFY	φ16x65	15039115	HARDENED & TEMPERED	20	0.103	45	26	13 ^{+1.8}	3.5	1.5	M10	0.27	0.036	930595160000	1
2	3.V.1135.03661/1		φ20x85	15039084			0.210	55	38	23 ^{+2.1}	5	2	M16	0.27	0.123	930595170000	2
3	3.V.1132.03661/1		φ25x90	15039086			0.347	60	46	23 ^{+2.1}	6	2.5	M20	0.33	0.205	930595180000	3
4	3.V.2663.03661/1		φ20x75	15039084			0.185	46	35	23 ^{+2.1}	5	2	M16	0.27	0.12	930602550000	4
5	3.V.1076.03661		φ16x80	15039115			0.13	55	35	20 ^{+2.1}	3.5	1.5	M10	0.27	0.05	930608660000	5
6	3.V.1705.03661		φ25x100	15039086			0.386	70	46	23 ^{+2.1}	6	2.5	M20	0.33	0.21	930609390000	6
7	3.V.5402.03661		φ20x118	15039084			0.29	85	38	23 ^{+2.1}	5	2	M16	0.27	0.19	930678070000	7
8	3.V.2899.03661		φ25x110	15039086			0.424	75	30	32 ^{+2.8}	6	2.5	M20	0.33	0.26	931006060000	8
9	3.V.2956.03661		φ16x70	15039115			0.11	45	25	20 ^{+2.1}	3.5	1.5	M10	0.27	0.04	931017320000	9
10	3.V.2961.03661		φ20x100	15039084			0.25	70	40	23 ^{+2.1}	5	2	M16	0.27	0.15	931019960000	10
11	3.V.P208.03661		φ25x110	15039086			0.42	65	35	35 ^{+2.8}	6	2.5	M20	0.33	0.25	931026230000	11
12	3.V.B555-03661	φ25x95	15039086	0.36	50	35	35 ^{+2.8}	6	2.5	M20	0.33	0.21	931035410000	12			
13	3.V.5142-03661	A193 B16	φ32x130	15039165	0.82	85	60	35 ^{+2.8}	6	2.5	M27	0.33	0.54	931037190000	13		
14	3.V.5618-03661	A193-B7, CERTIFY	φ16x95	15039115	HARDENED & TEMPERED	20	0.15	67	25	20 ^{+2.1}	3.5	1.5	M10	0.27	0.05	931666030000	14

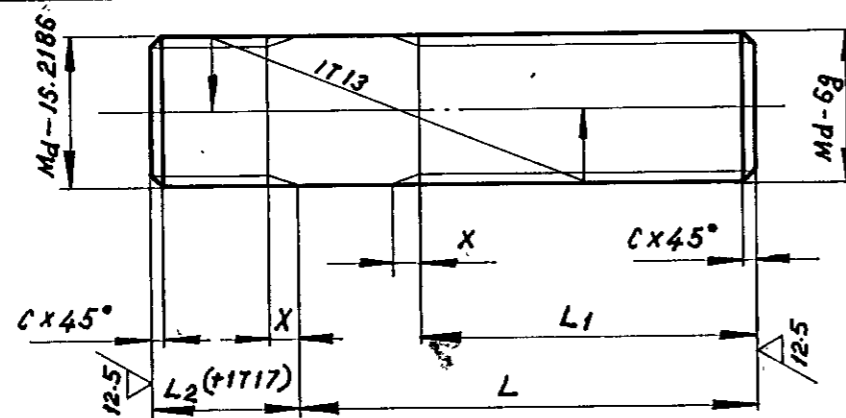

NO. OF PIECES	DESCRIPTION	SEM PRO./SEQ.NO.	INT. MAT. / SEQ. NO.	FINAL MATERIAL	SCRAP SORT	NET Wt (kg)	GROSS Wt (kg)	DRAWING NO.	ITEM NO.
RETRACED WITH REV. No. 10 ON 15.6.95									
BHARAT HEAVY ELECTRICALS LTD. BOILER PLANT UNIT, TIRUCHIRAPALLI-14									
FIRST ANGLE	SCALE	DRAWN	CHECKED	APPROVED	DATE	TOTAL NET WT. (kg)	TYPE	NEW/OLD DRG. NO.	
	NTS	R.L. Ramesh	R.L. Ramesh	M.R.K. An	15.6.95				
CAUTION THE INFORMATION CONTAINED IN THIS DRAWING IS THE PROPERTY OF BHARAT HEAVY ELECTRICALS LTD., BOILER PLANT UNIT, TIRUCHY-14 AND SHALL NOT BE USED WITHOUT THEIR EXPRESS WRITTEN PERMISSION IN ANY FORM OR PART THEREOF FOR ANY OTHER PURPOSE THAN FOR WHICH IT IS SENT TO YOU.									
								33-115	
STUD								DRAWING NO.	
3.V.0000.03661								REVISION	
10								10	

REV.	DATE	ALTERED	REV.	DATE	ALTERED	REV.	DATE	ALTERED
		CHE & APPD.			CHE & APPD.			CHE & APPD.
		CHE & APPD.			CHE & APPD.			CHE & APPD.
		CHE & APPD.			CHE & APPD.			CHE & APPD.
		CHE & APPD.			CHE & APPD.			CHE & APPD.



PLANT STANDARD

HPBP TIRUCHIRAPPALLI

BPS 41319

Rev. No. 03

PAGE 1 OF 2

NUTS FOR TEMPERATURE USE

(For medium of temperature upto 425 ° C)

1.0 SCOPE

Covers the requirements of hexagon nuts for use in medium of temperature upto 425 ° C and in the size range M8 to M45x3.

2.0 SPECIFICATION AND REFERENCE STANDARDS

Dimensions and preferred sizes	Fig 1 & Table 1 of this standard	
Tolerance	Product grade	A for nuts with $d \leq M16$ B for nuts with $d > M16$
	Indian Standard	IS 1367 (Part 2)
Thread	Pitch	Table 1 of this standards
	Tolerance	6H
	Indian Standard	IS 4218 (Part 3, 5 & 6)
Material	Steel to ASTM A 194 2H Certified	
Testing	The finished nut shall satisfy the requirements of hardness, proof load and cone proof load, tests as specified in ASTM A194	
General requirements	Nuts shall comply with TDC:5:166 in respect of requirements not covered in this standard, except for cadmium plating	

2.1 Referred standards (Only the relevant parts of current versions are applicable)

IS 1367 (Part 2)	Technical supply conditions for threaded steel fasteners
IS 4218 (Part,3,5 & 6)	ISO metric screw threads
TDC:5:166	Carbon steel nuts for OFE & other applications as per A 194 GR 2H/2HM
ASTM A194	Specification for carbon and alloy steel nuts for bolts for high pressure and high temperature service.

3.0 DESIGNATION

A Grade 'A' hexagon nut to this standard of thread size M8 shall be designated as :

3.1 On Drawings

i) Material Specification column	ASTM A 194 - 2H
ii) Description Column	NUT HEX GR A T425 M8
iii) Drawing Number Column	BPS 41319
iv) Material Code column:	4131900008

Revisions

Brought upto date

Approved

STANDARDS SECTION
CONTRACT ENGINEERING AND CO-ORDINATION
HPBP, TIRUCHIRAPPALLI

Rev. No. 03

Amd. No.

Reaffirmed

Prepared

Issued

Dt of 1st Issue

Dt. JUN 1997

Dt.

Year

STANDARDS

STANDARDS

DEC 1986

COPYRIGHT AND CONFIDENTIAL

The information on this document is the property of BHARAT HEAVY ELECTRICALS LIMITED. It must not be used directly or indirectly in any way detrimental to the interest of the company.

3.2 Ordering Description

For placing indents, issuing enquiries and on purchase order, Ordering Description given below shall be followed. (Typical examples)

Hex Nut M8 to BPS : 41319-A-ASTM A194-2H for nuts with $d \leq M16$

Hex Nut M20 to BPS : 41319-B-ASTM A194-2H for nuts with $d > M16$ and $d < M36 \times 3$

Hex Nut M36x3 to BPS: 41319-B-ASTM A194-2H for nuts with $d \geq M36 \times 3$

4.0 ADDITIONAL INFORMATION

4.1 Copies of this standard and TDC:5:166 shall be enclosed along with the purchase order.

Figure 1 DIMENSIONS FOR HEXAGON NUTS

(All dimensions are in millimetres)

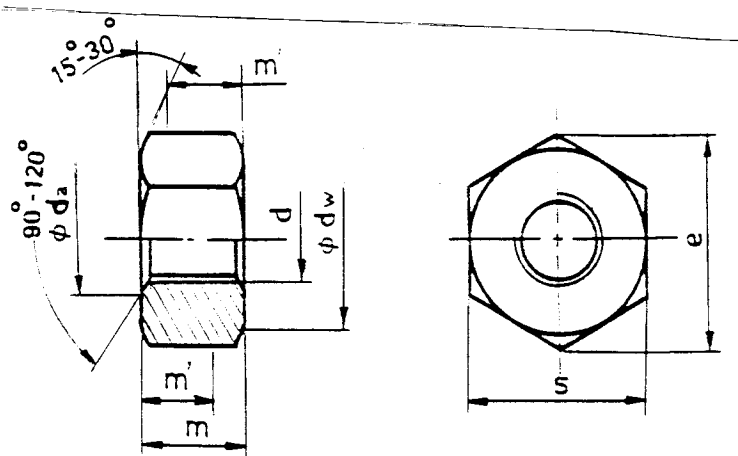

'm' = Effective gauging height

TABLE 1

(All dimensions are in millimetres)

Thread Size d	d _a		d _w	e		m		m'	s		Weight
	Min	Max		Min	Max	Min	Max		Min	Max	
M8	8	8.75	11.6		14.38	8	7.64	6.1	13	12.73	6.0
M10	10	10.80	14.6		17.77	10	9.64	7.7	16	15.73	10.8
M12	12	13.00	16.6		20.03	12	11.57	9.3	18	17.73	16.5
M16	16	17.30	22.5		26.75	17.1	16.40	13.1	24	23.67	33.0
M20	20	21.60	27.7		32.95	20.7	19.40	15.5	30	29.16	64.5
M24	24	25.90	33.2		39.55	24.2	22.90	18.3	36	35.00	110.0
(M27)					45.20	27.6	26.30	21.0	41	40.00	166.0
M30	30	32.40	42.7		50.85	30.7	29.10	23.3	46	45.00	231.0
(M33)					55.37	33	31.40	25.1	50	49.00	299.0
M36x3	36	38.90	51.1		60.79	36.6	35.00	28.6	55	53.80	364.0
(M39x3)					66.44	39	37.40	29.9	60	58.80	485.0
(M45x3)				80.8		45	43.40	34.7	70	68.80	750.0

NOTE :

1. Sizes in brackets are non-preferred.
2. Weights are given in Kg per 1000 numbers only.



Product: CARBON & ALLOY STEEL FASTENERS (STUDS, BOLTS & NUTS) FOR VALVES, OIL FIELD EQUIPMENT (OFE) AND OTHER APPLICATIONS

Revision Record: 00: 17.01.90: First issue. Rev: 01:21.06.90 Editorial corrections. Rev 02:21.04.91 TC for studs/bolts added. Rev 03: 04.04.96: Annexure I amended. CI 3.3.3 & 5.3 modified. Rev 04:20.10.96: NDT, Acid pickling added & re-written. Rev 05: 28.04.98: CI 3 modified to include MPI, certificate modified & CI 7.4 deleted. Rev 06:15.06.99: Title, CI 1 to 5 & 7.1 modified. CI 7.2 changed to CI 7.3. CI 7.3 changed to 7.4 and modified. CI 7.2 Galvanizing added. Test certificate sample format modified.
Rev 07: 15/06/2017: TDC: 5:166 for CS & AS Nuts has been merged with this TDC. Totally revised in line with changed requirements and Xylan coating requirements added.
Rev 08: 14/09/2019: CI 1.0, 2.0, 3.0, 4.0, 5.0 modified in line with API 6A 21st Ed 2018 Errata 1 and for better clarity.
Rev.09: 19/02/2021: Latest version of the referred Standards/Specifications indicated throughout TDC; CI.2.0 iid added; CI.4.1 added; Annexure-1 modified;

1.0 MATERIAL SPECIFICATIONS:

All the codes, standards, specifications, drawings & procedures, etc., referred in this TDC shall be of latest revision as on the date of Purchase Order, unless specified otherwise.

Studs/Bolts - Alloy Steel	:	ASME SA 193-19 /ASTM A 193-20 Gr B7, B7M & B16.
Nuts - Carbon Steel	:	ASME SA 194-19 /ASTM A 194-20A Gr 2H & 2HM
Alloy Steel	:	ASME SA 194-19 /ASTM A 194-20A Gr 4 & 7
Additional Requirements	:	As listed below (Supplementary to the above material specifications)
Size and Quantity	:	As per Purchase Order (PO) & Applicable Drawing

2.0 GENERAL REQUIREMENTS:

- i. This TDC is applicable for Valves, OFE (API 6A 21st Ed 2018 Errata 3 Addendum 1 & API 16C 2nd Ed 2015 Addendum 1 Errata 4) and other applications including NACE MR0175 / ISO 15156:2015 Parts 1, 2 & 3. The products shall be manufactured to the relevant requirements specified in the applicable drawings, specifications, PO & this TDC.
- ii. Studs / Bolts / Nuts used for OFE application:
 - a. Studs / Bolts / Nuts shall be qualified and manufactured in accordance with BSL 1 of API 20E. The qualification & requalification records as per API 20E Ed 2017 Addendum 2 shall be maintained by the Supplier. The supplier shall prepare Manufacturing Process Specification(MPS) to include as a minimum allowable levels for all Studs/Bolts/Nuts manufacturing parameters including process control variables and heat treatment parameters as per API 20E Ed 2017 Addendum 2 and this TDC.
 - b. Raw material shall be fully wrought. Reduction ratio based on starting material diameter shall be a minimum of 4:1. The steel shall conform to the respective material specifications. Intentional addition of Boron is not allowed. All elements intentionally added to the heat shall be reported in the Test Certificate.
 - c. Furnace calibration shall be in accordance with API 6A 21st Ed 2018 Annex M; SAE AMS 2750 Rev.F; or SAE AMS H6875 Rev.C. For induction or direct resistant heat treatment, calibration shall be in accordance with manufacturer's written procedure. For forging furnaces, calibration shall be in accordance with manufacturer's written procedure
 - d. Heat lot:
 - Batch furnace: bolting or raw material of a single heat and diameter, heat treated together as a single austenitizing, quenching, tempering, and stress-relieving charge.
 - Continuous furnace: bolting or raw material of a single heat and diameter heat treated without interruption in a continuous charge
- iii. Nuts shall be hot/cold forged or manufactured from hot rolled/cold drawn bars. If made from

	BHEL – Tiruchirappalli - 620014, India. Quality Assurance Department TECHNICAL DELIVERY CONDITIONS	DOC No: TDC:5:164 Rev: 09 Effective Date: 19/02/2021 Page: 2 of 7
Product: CARBON & ALLOY STEEL FASTENERS (STUDS, BOLTS & NUTS) FOR VALVES, OIL FIELD EQUIPMENT (OFE) AND OTHER APPLICATIONS		

hexagonal bars, 100% MT is to be done on bars as per ASTM E709-15 to ensure freedom from surface/sub-surface defects.

- iv. Hot rolled & cold drawn bars, if used (for studs/bolts or nuts), shall be machined at least 2 mm (minimum) in radius (i.e. 4 mm in diameter) to remove the seams completely. After machining, at least 10% of the bars shall be tested by MPI as per ASTM E709-15 to ensure freedom from surface/sub-surface defects.
- v. Heat treatment of finished studs/bolts shall be carried as per the material specification requirements for corresponding grades. For heat treatment of finished components, salt bath or controlled atmosphere furnace shall be used. After heat treatment, the threads shall be thoroughly cleaned to remove all deposits. If acid pickling is done for cleaning, it shall be as per Cl. 6 (v) of this TDC.
- vi. Cadmium Plating (Cl 6 (i) of this TDC), Electroplating (Cl 6 (ii) of this TDC) and/or Xylan Coating (Cl 6 (iii) of this TDC) shall be done on the fasteners if specified in Drawing/PO. For all other cases, rust preventive coating (Cl 6 (iv) of this TDC) shall be done.

3.0 CHEMICAL, MECHANICAL PROPERTIES & NDE:

- i. Mill certificate from steel manufacturer for conformance to chemistry heat-wise shall be submitted. Additionally, product analysis shall be done on one sample/heat by the stud/bolt/nut manufacturer. Methods and practices for chemical analysis shall be in accordance with ASTM A 751-20.
- ii. The microstructure and macrostructure shall conform to the requirements of the respective material specifications.
- iii. **Tensile Testing for Studs/Bolts:** One tensile test/heat/size/ HT batch shall be carried out in the finished heat treated condition as per SA / A 193 and shall meet the material specification requirements for corresponding grades.

iv. Hardness Testing for Studs/Bolts:

Hardness testing, including specimen preparation, shall be performed in accordance with ASTM A 370-20 including Annex A3, except that testing shall also be in conformance with ASTM E10-18 or ASTM E18-20.

- a) **For ASME SA 193-19 / ASTM A 193-20 Gr B7 & B16:** Hardness check shall be carried out on finished stud/ bolt as per ASME SA 193-19 / ASTM A 193-20, at least on 10% of the finished studs/bolts.

Gr B7: Hardness: 25 to 34 HRC or 253 to 319 HBW.
Gr B16: Hardness: 25 to 35 HRC or 253 to 321 HBW.

- b) **For ASME SA 193-19 / ASTM A 193-20 Gr B7M:**

Hardness check on 100% of studs/bolts as per SA193.
Gr B7M: Hardness: 94 to 99 HRB or 201 to 235 HBW.

v. Mechanical Testing for Nuts:

- a) **For ASME SA 194-19 / ASTM A 194-20A Gr 2H, Gr 4, & Gr 7:**

Hardness check on finished nuts shall be as per ASME SA 194-19 / ASTM A 194-20A (including quantum of testing).

Gr 4: Hardness: 24 to 35 HRC or 248 to 327 HBW.

Gr 2H & Gr 7: Hardness: 24 to 34 HRC or 248 to 319 HBW.

- b) **For ASME SA 194-19 / ASTM A 194-20A Gr 2HM:**

Hardness check on 100% of finished nuts shall be carried out as per ASME SA 194-19 /



Product: CARBON & ALLOY STEEL FASTENERS (STUDS, BOLTS & NUTS) FOR VALVES, OIL FIELD EQUIPMENT (OFE) AND OTHER APPLICATIONS

ASTM A 194-20A.
Gr 2HM: Hardness: 159 to 235 HBW.

- c) **Proof load test shall be done as per ASME SA 194-19 / ASTM A 194-20A for all grades of nuts** and shall meet the requirements of corresponding grades of the material specification.
- d) After final heat treatment, sample nuts shall be heat treated as per Table 1 and meet the corresponding hardness requirements.

Table 1.

Grade	Temperature (°C)	Soaking Time (Hr)	Cooling	Minimum Hardness (HBW) at room temperature
2H	540	24	Slow Cool	179
2HM	540	24	Slow Cool	159
4, 7	590	24	Slow Cool	201

- e) **Cone Stripping Test:** This test shall be performed as per ASME SA 194-19 / ASTM A 194-20A in case of visible surface discontinuities. On such cases Proof load shall be as per ASME SA 194-19 / ASTM A 194-20A.
- vi. **NDE:**
Magnetic particle inspection shall be carried out as per ASTM E709-15 in at least 10% of the finished studs/bolts of all grades. Cracks, linear indications (length \geq 3 times its width) are unacceptable.

4.0 SAMPLING INSPECTION:

All inspection shall be in accordance with relevant drawing or BPS (Boiler Plant Standard), PO, this TDC and ASME SA 193-19 / ASTM A 193-20 for studs/bolts and ASME SA 194-20 / ASTM A 194-20A for nuts. The threads shall be checked with calibrated ring gauges for studs/bolts & plug gauges for nuts in the final heat treated condition for black variety and *prior to* final plated/coated condition for the cadmium plated/electroplated/ xylan coated items.

Visual, dimensional checks and their acceptance shall be as per applicable drawing and ASME SA 193-19 / ASTM A 193-20 for studs/bolts & ASME SA 194-20 / ASTM A 194-20A for nuts.

4.1 Gauging Requirements for Xylan along with Zinc Coated Fasteners

- i. **Studs**
- No under sizing is allowed
 - Prior to Xylan and Zinc Coating, Class 2A Gauge to be used for inspection
 - After coating, No Gauge inspection is required
- ii. **Nut**
- Under sizing is allowed to maximum of 0.2mm in the internal diameter of threads
 - Prior to under sizing, Class 2B Gauge to be used for inspection
 - After under sizing, a gauge having an allowance as per Class 2B along with 0.2mm under sizing allowance to be made and inspected thereof
- iii. **Assembly of Stud and Nut**
- Free run of nut over stud to be ensured
 - No play is allowed
 - After free run of nut over stud, Xylan coating should not get peeled off.

5.0 MARKING & PACKING:

- Punch/emboss each finished component with applicable material grade (B7/ B7M/ B16 for studs/bolts; 2H/2HM/4/7 for nuts) and supplier's emblem. Studs/bolts of grade B7M and nuts of Gr 2HM shall have a line under the grade symbol.
- Punch/emboss serial number also in B7M studs/bolts and Gr 2HM nuts in addition to the above, to correlate with hardness. Protect the threaded ends with plastic end caps. Pack in wooden



Product: CARBON & ALLOY STEEL FASTENERS (STUDS, BOLTS & NUTS) FOR VALVES, OIL FIELD EQUIPMENT (OFE) AND OTHER APPLICATIONS

box/ gunny bag of convenient size for easy handling and transportation. Mark quantity in each box/gunny bag.

- iii. In addition to the above, studs / Bolts / Nuts for OFE applications shall marked with unique heat lot identification and followed by "20E1". Each piece 1 in. nominal diameter and larger shall be marked. For studs / Bolts / Nuts less than 1 in. nominal diameter, the studs / Bolts / Nuts shall be securely containerized to maintain heat lot identification and traceability. Multiple heat lots shall not be mixed in a single container. Containers used in the processing, storing, and shipping of studs / Bolts / Nuts not individually marked shall be clearly labeled with all marking information required by the relevant material specifications and API 20E Ed 2017 Addendum 2.

6.0 SPECIAL REQUIREMENTS:

i. CADMIUM PLATING:

- a) Clean the fasteners to make them free from rust, grease, oil, scale, etc., before plating. When pickling is considered essential, it shall be done as per Cl 6 (v) of this TDC.
- b) Apply Cadmium Plating to the specified thickness on specified areas. Thickness shall be measured on 5% of the PO quantity of fasteners.
- c) After plating, bake the parts at 175°C to 205°C for a minimum period of 3 hours. The elapsed time between plating and baking shall not exceed 8 hours.
- d) Apply a Chromate Conversion coating after plating and baking.

ii. ELECTROPLATING OF ZINC CHROMATE:

- a) Clean the fasteners to make them free from rust, grease, oil, scale, etc., by suitable organic solvents/ hand tool methods before electroplating. Then, pickling shall be done as per Cl 6 (v) of this TDC.
- b) The fasteners shall then be electroplated as per the method and to the minimum coating thickness specified in the applicable drawing. Thickness shall be measured on 5% of the PO quantity of fasteners.
- c) All electroplated parts (regardless of strength level) shall be baked within 2 hours after plating at 375 °F–425 °F (191 °C–218 °C) for 8 hours minimum at temperature

iii. XYLAN COATING:

- a) Clean the fasteners by blast cleaning to Sa2.5 to make them free from rust, grease, oil, scales, etc., before xylan coating.
- b) The fasteners shall then be xylan coated as per the requirements and to the minimum coating thickness specified in the applicable drawing.

c) Tests for Xylan Coating:

The following test shall be carried out on Xylan coated fasteners and results to be reported in the Test certificate (in addition to the Test Certificate for the fastener material and other inspections requirements):

i) Thickness measurement:

Dry film thickness of Xylan coating to be measured using a magnetic induction or Eddy current type electronic gauge and the reading shall meet the drawing/PO requirement for thickness of coating of Xylan 1070. The thickness measurements shall be made in accordance with ASTM D7091-20. Thickness shall be measured on 5% of the PO quantity of fasteners.

ii) Cure Test:

This test method is for ensuring the completeness of cure of Xylan 1070 coating by evaluating the resistance of the cured coating to a solvent known to attack uncured film. The testing method shall be as per Whitford test method 115B (as recommended by the Xylan coating supplier).

Acceptance criteria: No white precipitate or stain shall be available after the test.

iii) Adhesion Test using Cross-hatch and Cello Tape:

	BHEL – Tiruchirappalli - 620014, India. Quality Assurance Department TECHNICAL DELIVERY CONDITIONS	DOC No: TDC:5:164 Rev: 09 Effective Date: 19/02/2021 Page: 5 of 7
	Product: CARBON & ALLOY STEEL FASTENERS (STUDS, BOLTS & NUTS) FOR VALVES, OIL FIELD EQUIPMENT (OFE) AND OTHER APPLICATIONS	

Test as per ASTM D3359-17 Method B for measuring Adhesion by Tape Test.
Acceptance Criteria: No loss of adhesion (5B Classification).

iv) Salt Spray Test:

Xylan coated fasteners should pass a minimum requirement of 500 hours of salt spray test as per ASTM B117-19. Certificate of compliance for meeting the salt spray test requirements shall be provided.

iv. RUST PREVENTIVE FLUIDS/COATING REQUIREMENTS:

- a) Clean the fasteners to make them free from rust, grease, oil, scale, etc., by hand tool/ manual cleaning method.
- b) Apply one coat of rust preventive fluid, of any of the following brands of the suppliers (Table 2), to obtain dry film thickness of 20 microns minimum:

Table 2. Rust Preventive Fluid/Coatings Brands

SI No	Brand/Chemical	Supplier Name and Address
1	BONITA-RPF	M/s Bonita Chemicals, 64, Industrial Estate, Nunhai, Agra-282 006
2	CHAMPION-RPF	M/s Guardian Chemicals, 8, Rajaji Hind st, West Lake Area, Nungambakkam, Madras-600 034
3	ECONOL RPF (non-drying type)	M/s Process Aids, Bangalore
4	TECTYL 506	M/s Plastipeel Chemicals and Plastics (P) Ltd, Thane-400 604
5	TRPF	M/s Sundaram Paints Pvt. Ltd., Thanjavur-613 004
6	TRPF	M/s Solar Paints, Pudukkotai.
7	WICOR-P	M/s Western India Paint and Color Co P. Ltd, Madras-600 017

Use of any other brand/chemical shall be done with the prior approval of BHEL.

v. ACID PICKLING:

- a) Wherever pickling done, it shall be done using Hydrochloric acid of 5-10% concentration for a period of 5 to 10 minutes at room temperature with suitable inhibitor.
- b) After pickling thorough rinsing shall be carried out with water to remove acid residues & further DM water rinsing. After thorough rinsing with DM water, the rinsing shall not show any red color (free acidity) when tested with methyl orange indicator.

7.0 CERTIFICATION:

The manufacturer shall provide Test Certificates (TC) duly countersigned by the Authorized Inspecting Authority nominated by BHEL in P.O. (if specified) along with raw material TC from Steel Maker. *The applicable versions of the referred Codes, Standards and Specifications shall be reported in the Test Certificates and NDE reports.* Manufacturer's TC shall contain the following details as per the sample format attached as Annexure-1 to this TDC:





- i. BHEL PO No & PO Date
- ii. Technical Delivery Condition (TDC) No & its Revision No, Drawing & its revision no
- iii. Melt/Heat No, Serial No (if applicable)
- iv. Raw Material TC Number and Date
- v. Chemical and Mechanical properties for Studs/Bolts and Nuts *including the location and orientation of test specimens*
- vi. Heat treatment details (temperature, time, cooling medium, etc.)
- vii. *NDE reports with NDE Personnel qualification records, all relevant NDE operating parameters and NDE Results with reference and acceptance criteria*
- viii. Type of Surface coating & its coating thickness – Cadmium Plating, Chromate conversion coating, Electroplating, Xylan Coating, Rust preventive coating, etc.
- ix. Test methods and results on Xylan Coating
- x. Baking details for cadmium plating, electroplating & Xylan coating
- xi. Manufacturers' identification mark
- xii. Certify soundness & confirmation to PO requirements.

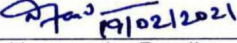

BHEL – Tiruchirappalli - 620014, India.
Quality Assurance Department
TECHNICAL DELIVERY CONDITIONS

DOC No: TDC:5:164 Rev: 09
Effective Date: 19/02/2021
Page: 6 of 7

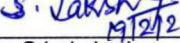
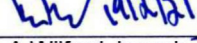
Product: CARBON & ALLOY STEEL FASTENERS (STUDS, BOLTS & NUTS) FOR VALVES, OIL FIELD EQUIPMENT (OFE) AND OTHER APPLICATIONS

 19/02/2021	 19/2/21	 19/2/21	 19/2/21	 19/02/2021
N Nagamuthu Pandian	P Arun kumar	S Lakshmi	A Wilfred Joseph	J V V Aruna Kumar
Manager/QA	DM / Valves Engg	DGM/QA	AGM / Valves/MM	SDGM / QA
Prepared By	Reviewed By			Approved By



Product: CARBON & ALLOY STEEL FASTENERS (STUDS, BOLTS & NUTS) FOR VALVES, OIL FIELD EQUIPMENT (OFE) AND OTHER APPLICATIONS

Annexure-1. Test certificate for Studs/Bolts & Nuts– Sample format

TC No:	Date:
Customer :	PO No./ Amd :
TDC No./Rev.:	DC No. :
Product :	Drg. No./Rev :
Description : (Spec, dia, pitch, length)	Thread Spec. :
Quantity :	
<u>Requirement</u> :	<u>Records/ Observation</u>
Size of bar - Before machining :	
- After machining :	
Type of furnace used for hardening :	

TDC Clause no.	Raw Material mill TC No: Melt/Heat Number:	TC Date: Reduction Ratio:
2.0 & 3.0	a) Heat Treatment Details: Hardening Temperature: °C; Soaking time: Cooling Medium: Tempering Temperature: °C; Soaking time: Cooling Medium: b) Additional Tempering for Nuts (after final tempering): Temperature: °C; Soaking time: Cooling Medium:	
3.0	a) Product analysis for chemistry	
	Report No & Date:	
	Spec	C Mn P S Si Cr Mo V Ni Others
	Min.	
	Max.	
	Actual	
	b) Tensile test after H & T and final drying (Finished heat treated condition) – For Studs/Bolts	
		UTS (MPa) YS (MPa) %Elongation %Red in Area
	Reqd/Spec Value	
	Test result	
	Spec Value Test result Remarks	
	c) Hardness Test Result (for Studs/Bolts, Nuts):	
	d) Hardness Test Result (for Nuts after 24 hrs of tempering):	
	e) Proof load (kN) for nuts & result	
	f) Result of Cone Stripping test for nuts	
	g) NDE Result for Studs/Bolts:	
4.0	Visual and dimensional checking as per applicable drawing for studs/bolts & nuts:	
5.0	Punching details (identification): End cap for threaded portion:	
6.0	a) Type of coating: Cadmium Plating /Chromate Conversion / Electroplating/ Xylan /Rust preventive coating (Tick applicable coating) Coating thickness/DFT:	
	b) Tests for Xylan Coating	Results
	c) Pickling Acid: Concentration: Drying after pickling. Temperature: °C; Soaking time:	

This is to certify that the above results are correct and the parts meet specification and PO requirements.

Signature with date Supplier: In-charge of Quality	Signature with date BHEL / Authorized Inspection Agency
---	--

Note: Additional Sheets may be attached, if required.



भारत हैवी इलेक्ट्रिकल्स लिमिटेड

(भारत सरकार का उपक्रम)

इंडस्ट्रियल वाल्वस प्लांट

Bharat Heavy Electricals Limited

(A Govt. of India Undertaking)

Industrial Valves Plant

Quality Assurance Plan for Fasteners*:
NUT, BOLT (INCL EYE BOLT, LIFTING EYE BOLT), STUD

BHE:QAP:FAS:02
Dt:15.03.2019

SN	Stage of inspection	Inspection type		Ref doc	Quantum of check	Format of Record	Agency	
							M	BHEL/TPIA
1	Raw material	Chemical/Mechanical properties		Material test certificate	100%	MTC report	V	V
2	Finished product	Chemical Analysis	Chemical composition	Material specification in drg	one sample per heat	Annex 1 of TDC	P	W
		Mechanical Properties	Tensile strength	Material specification in drg	one sample per heat	Annex 1 of TDC	P	W
			Mechanical testing for nut		10% or 20 nos			
			Hardness		hardness check at manufacturer end, one sample each type per heat for TPIA or BHEL**			
		Dimension	As per drawing, Thread with GO/ NO GO Gauge	Material drg/BPS	10% or 20 nos/type.	Inspection report	P	P
		Visual	Free from burrs, physical damages		100%	Annex 1 of TDC	P	P
MPI	ASTM E709	As per procedure	10% or 20 nos/type.	MPI report	P	W		
Marking/Identification	Material grade/supplier name or symbol	As per PO/Drawing/TDC	10%	Annex 1 of TDC	P	W		

Vid
15/03/19
(MKS/MP)

S. R. Kanwar
15/03/19
(S. R. Kanwar)

S. R. Kanwar
15/03/19
S. R. Kanwar



भारत हैवी इलेक्ट्रिकल्स लिमिटेड

(भारत सरकार का उपक्रम)

इंडस्ट्रियल वाल्वस प्लांट

Bharat Heavy Electricals Limited



(A Govt. of India Undertaking)

Industrial Valves Plant

3	Rust preventive oil		As per TDC:5:164	100%	Annex 1 of TDC	P	W
	Packing	Packed in wooden/cardbo ard box with layer to layer cushioning material.		10%	Annex 1 of TDC	P	W
	Test certificate	MTC			Annex 1 of TDC	P	V

M-Manufacturer, V-Verification, W-Witness, P-Perform

- * QAP IS PREPARED TO MEET REQUIREMENT OF TDC:5:164 (latest), PLS REFER IT, IN CASE OF AMBIGUITY ARISES.
- ** TPIA/BHEL MAY INCREASE SAMPLE QTY UP TO 10%.

 Vikas Kumar Sr. Engr / QM Prepared	 Samir Shandilya Sr Mgr/ QM &HSE Reviewed	 S R Kenny AGM/QM, HSE, Engg, TEC & SM) Approved
---	---	--



भारत हेवी इलेक्ट्रिकल्स लिमिटेड
 (भारत सरकार का उपक्रम)
इंडस्ट्रियल वाल्वस प्लांट
Bharat Heavy Electricals Limited
 (A Govt. of India Undertaking)
Industrial Valves Plant

Standard Quality Assurance Plan for Stainless steel fasteners

BHE:SQAP:SS:01

Dt:12.08.2021

SN	Stage of inspection	Inspection type		Ref doc	Quantum of check	Format of Record	Agency	
							M	BHEL/TPIA
1	Raw material	Chemical/Mechanical properties		Material test certificate	100%	MTC report	V	V
2	Finished product	Chemical Analysis	Chemical composition (for both stud and nut)	Material specification in drawing/PO	one sample per heat	Chemical Test Report	P	W
		Mechanical Properties	Tensile strength	Material specification in drawing/PO	one sample per heat	Mechanical Test Report	P	W
			Yield strength/Proof Load (for both stud and nut)		one sample per heat			
			Elongation		one sample per heat			
			Reduction of area		one sample per heat			
			Hardness (for both stud and nut)		10% or 20 nos.			
Dimension	As per drawing, Thread with GO/ NO GO Gauge (for both stud and nut)	Material drg/BPS	10% or 20 nos/type whichever is lower.	Inspection report	P	P		

अमनप्रीत सिंह / Amanpreet Singh
 उप प्रबंधक / Dy. Manager (QM)
 भारत हेवी इलेक्ट्रिकल्स लिमिटेड
 Bharat Heavy Electricals Limited
 (A Govt. of India Undertaking)
 इंडस्ट्रियल वाल्व प्लांट / Industrial Valves Plant
 गोइंदवाल साहिब / Goindwal Sahib (Tarn Taran) - 147 122

Manvir Singh
 Sr. Manager (QM)
 BHEL, IVP, Goindwal

(Signature)



भारत हेवी इलेक्ट्रिकल्स लिमिटेड
 (भारत सरकार का उपक्रम)
इंडस्ट्रियल वाल्वस प्लांट
Bharat Heavy Electricals Limited
 (A Govt. of India Undertaking)
Industrial Valves Plant

	Heat Treatment	-----	Material specification in drawing/PO	100%	Heat Treatment Report	P	V
	Visual	Free from burrs, physical damages		100%		P	P
	Marking/Identification	Material grade and supplier name or symbol	As per PO/Drawing/Applicable Standard	10%		P	W
3	Packing	Packed in wooden/cardboard box with layer to layer cushioning material.	As per PO/Drawing/Applicable Standard	10%		P	W

M-Manufacturer, V-Verification, W-Witness, P-Perform

- QAP IS PREPARED TO MEET REQUIREMENT OF ASTM 193 & ASTM 194 (Latest Revisions), PLS REFER IT, IN CASE OF AMBIGUITY ARISES.
- TPIA/BHEL MAY INCREASE SAMPLE QTY UP TO 10%.

 अमनप्रीत सिंह / Amanpreet Singh उप प्रबंधक / Dy. Manager (QM) भारत हेवी इलेक्ट्रिकल्स लिमिटेड Bharat Heavy Electricals Limited (A Govt. of India Undertaking) इंडस्ट्रियल वाल्वस प्लांट / Industrial Valves Plant गोइन्दवाल साहिब / Goindwal Sahib (Dist. Tarn Taran)	 Manvir Singh Sr. Manager (QM) BHEL, IVP, Goindwal	
Amanpreet Singh Dy. Manager / QM	Manvir Singh Sr Mgr/ QM & BE	S R Kenny AGM/QM & BE
Prepared	Reviewed	Approved