



Bharat Heavy Electricals Limited
Industrial Valves Plant
Goindwal Sahib (Punjab)

Enquiry No.
2223-045E

Date:
28.09.2022

NOTICE INVITING TENDER (NIT)

Dear Sir / Madam,

BHEL Goindwal Sahib (Punjab) invites offers from interested bidders / suppliers for submission of their offer through e-procurement mode at <https://eprocurebhel.co.in/>. Offers in any other mode will not be accepted. In case of any difficulty faced while registering on BHEL's e-Procurement portal developed by NIC, queries may be addressed to 0120-4001002, 0120-4001005 and 0120-6277787; email: support-eproc@nic.in. These details are also available on 'Contact Us' page of the portal.

This tender is referred to M/s. Dalbir Engg. Works, Goindwal Sahib (Punjab).

Tender enquiry no. & date	2223-045E dated 28.09.2022
Form of contract	Supply
Tender / Item description	Supply of Wooden Boxes & Planks
Material standard / Drawings	As per attached TDC(s) & Drawings
Location(s) of Supply / Work	BHEL, Industrial Valve Plant, Goindwal Sahib, Dist. Tarn Taran -143422 (Punjab)
Earnest Money Deposit (EMD)	Not Applicable
Quotation parts	Two Part Bid
Tender download / Bid submission start date	28.09.2022 (17:30 Hrs. IST)
Tender download / Bid submission end date	10.10.2022 (12:00 Hrs. IST)
Tender / Bid opening date	10.10.2022 (15:30 Hrs. IST)
Validity of offer (In days)	30 days from techno commercial bid opening (Part-I)
Reverse auction	Not Applicable
Integrity pact (IP)	Not Applicable
Non-disclosure agreement	Not Applicable
Contact person details	Sh. Sumeet Bansal, Sr. Manager 01859-224 628, sbansal@bhel.in Sh. Sahil Malhotra, Dy. Manager 01859-224 603, sahil@bhel.in



BHEL IVP
GOINDWAL SAHIB

SPECIAL TERMS AND CONDITIONS

Tender enquiry no. 2223-045E dated 28.09.2022 Due date 10.10.2022

Tender Description: Supply Wooden Boxes & Planks

This tender is through e-procurement mode. Tender documents can be downloaded from <https://eprocarebhel.co.in>

This tender is referred to M/s. Dalbir Engg. Works, Goindwal Sahib (Punjab).

Tender enquiry no. & date	2223-045E dated 28.09.2022
Tender / Item description	Supply of Wooden Boxes & Planks
Material standard / Drawings	As per attached TDC(s) & Drawings
Location(s) of Supply / Work	BHEL, Industrial Valve Plant, Goindwal Sahib, Dist. Tarn Taran -143422 (Punjab)
Quotation parts	Two Part Bid
Tender download / Bid submission start date	28.09.2022 (17:30 Hrs. IST)
Tender download / Bid submission end date	10.10.2022 (12:00 Hrs. IST)
Tender / Bid opening date	10.10.2022 (15:30 Hrs. IST)
Validity of offer (In days)	30 days from techno commercial bid opening (Part-I)
Reverse Auction	Not Applicable

Note: The wooden packing boxes can also be assembled by vendors in the premises of BHEL IVP Goindwal Sahib. Unloading of material at Main Stores of BHEL shall be arranged by BHEL.

S1 SCOPE OF SUPPLY

Material shall be supplied as per the applicable Material Standard requirements/BPS/Drawing/IS and other requirement as mentioned in this tender document/Purchase Orders against this tender enquiry.

Material Code	Material description	Drawing no. / Rev no.	TDC no. / Rev no.	Quantity, nos.
GWB67035002	Box no 2A	4-V-4000-071B3	TDC:WOODENBOX/06	10
GWB67035009	Box no 10A	2-SH-BW-022/15	TDC:WOODENBOX/06	10
GWB67035014	Box no 16	2-SH-BW-022/15	TDC:WOODENBOX/06	10
GWB67035108	WOODEN PLANK 1"X4"X36" (INCHES)	-----	TDC:WOODENBOX/06	100
GWB67035106	WOODEN PLANK 2"X4"X38" (INCHES)	-----	TDC:WOODENBOX/06	100



BHEL IVP
GOINDWAL SAHIB

SPECIAL TERMS AND CONDITIONS

Tender enquiry no. 2223-045E dated 28.09.2022 Due date 10.10.2022

Tender Description: Supply Wooden Boxes & Planks

S2 **PART-I: TECHNO-COMMERCIAL BID** should contain *all the documents / confirmations as per following details:*

- a) Acceptance of Techno-Commercial terms and conditions shall be attached along with bid document. This can be attached either by signing each page of terms and conditions or a confirmation statement.

IF THE OFFER IS NOT ACCOMPANIED WITH ACCEPTANCE OF TERMS AND CONDITIONS, IT SHALL BE CONCLUDED THAT ALL THE TERMS AND CONDITIONS ARE ACCEPTABLE AND NO CLAIM WHATSOEVER SHALL BE ENTERTAINED LATER ON.

- b) MSE vendors should submit **Udyam Registration Certificate** for availing applicable benefits for MSE vendors as per tender terms.

S3 **PRICE BASIS**

- a. Rates shall be quoted on **rate INR per piece basis & on FOR GOINDWAL basis. Comparison shall be made on landed rate per piece to BHEL Goindwal for deciding L1 offer. Evaluation shall be done line item wise.**
- b. Unloading of material at Main Stores of BHEL shall be arranged by BHEL.
- c. Order of enquiry item sl. no. shall be maintained in the quotation.
- d. Quoted rates shall be firm during the currency of the contract.

S4 **DELIVERY SCHEDULE**

Delivery shall be within 60 days from the date of Purchase Order.

S5 **VALIDITY OF OFFERS**

The offers shall be kept valid for 30 days from the actual date of techno-commercial bid (Part-I) opening.

S6 **SECURITY DEPOSIT**

An amount equal to 1% of basic value shall be deducted each invoice. Interest free Security Deposit (full or partial after deduction of any amount chargeable from vendor) shall be refunded after successful completion of order(s) against this rate contract.

S7 **Others**

Liquidated damages (LD) for late delivery (i.e. clause no. 10 of GCC) and risk purchase clause (i.e. clause no. 19 of GCC) will not be applicable in this tender.

These Special terms and conditions and General Contract Conditions (GCC) collectively form the part of tender terms and conditions. Any term in special tender terms and conditions will supersede the GCC.



General Contract Conditions (GCC) of MM Tenders

BHARAT HEAVY ELECTRICALS LIMITED

Industrial Valve Plant: 433, Industrial Complex,
Goindwal Sahib, Dist. Tarn Taran,
Punjab-143422 (INDIA)

TABLE OF CONTENTS

1. INSTRUCTION TO BIDDER.....	2
2. SCOPE OF SUPPLY	2
3. PRICE BASIS	3
4. DISCREPANCY IN WORDS AND FIGURES.....	3
5. EVALUATION IN CASE OF MORE THAN ONE L-1 BIDDER.....	3
6. REVERSE AUCTION	4
7. VALIDITY OF OFFERS	4
8. SUPPLIED MATERIAL ADJUSTMENT.....	4
9. DELIVERY SCHEDULE	4
10. LIQUIDATED DAMAGES (LD) FOR LATE DELIVERY	4
11. PAYMENT TERMS	5
12. TAXES & DUTIES.....	5
13. LIABILITY UNDER REVERSE CHARGE (RCM)	6
14. ACCESS TO MANUFACTURING PREMISES	6
15. INSPECTION	6
16. GUARANTEE / WARRANTEE AND CORRESPONDING REPAIR / REPLACEMENT OF GOODS.....	7
17. LOI (LETTER OF INTENT).....	7
18. SUB-CONTRACT	7
19. RISK PURCHASE.....	7
20. FORCE MAJEURE	8
21. NON-DISCLOSURE AGREEMENT.....	9
22. CLARIFICATIONS	9
23. PREFERENCES FOR MICRO AND SMALL ENTERPRISES (MSEs).....	9
24. PREFERENCE TO MAKE IN INDIA	10
25. RESTRICTIONS UNDER RULE 144(XI) OF THE GENERAL FINANCIAL RULES (GFRs), 2017	10
26. DISPUTES.....	11
27. JURISDICTION.....	11
28. BANNED FIRMS	11
29. FRAUD PREVENTION POLICY.....	11
30. PREVENTIVE CHECKS TO ELIMINATE SUSPECTED CARTEL FORMATION .	11
31. SUSPENSION OF BUSINESS DEALINGS WITH DEFAULTERS.....	11
32. GENERAL.....	12





General Contract Conditions (GCC) of MM Tenders

BHARAT HEAVY ELECTRICALS LIMITED

Industrial Valve Plant: 433, Industrial Complex,
Goindwal Sahib, Dist. Tarn Taran,
Punjab-143422 (INDIA)

1. INSTRUCTION TO BIDDER

Quotations shall be submitted before due date and time. Late offers are liable to be rejected, so please ensure to submit bid well within due date and time. Techno-commercial part will be opened on due date.

Based on evaluation of techno-commercial offers, Price bids of bidders who qualify from techno-commercial evaluation shall be opened. BHEL may decide to open the Price bid same day at 1700 hrs. If not opened on the same day, all qualifying bidders shall be notified for date of opening of Price bids by email/fax/post/courier/E-procurement system generated email.

1.1 Instruction to Bidder (In case of Non-E-Procurement / Paper/ Manual/ Hard Copy based tenders)

Sealed Tenders can be dropped in the tender box labeled as 'Tender box for MM contracts'. This tender box is located at the entrance of Admin block BHEL Goindwal. Quotations can also be submitted through e-mail at tendermm_ivp@bhel.in. Offers received in time shall be considered only when offers are complete in all respects. In case of bulky tenders, please handover quotation to Sh. Rakesh Kumar/ SDGM - Head-MM or Sh. Sumeet Bansal / Sr. Manager - MM [Contact: 01859 224 615 / 628]. Bid can be sent to following address:

**BHEL, Industrial Valve Plant,
#433, Industrial Complex,
Goindwal Sahib, Distt. Tarn Taran,
Punjab-143422.**

1.2 Instruction to bidder (In case of E-Procurement)

- Interested bidders / suppliers shall submit their offer through e-procurement mode at <https://eprocurebhel.co.in/>.
- Offers in any other mode will not be accepted.**
- Procedure for submission of tender is available in the "Bidder Manual Kit" at e-tender portal <https://eprocurebhel.co.in/>.
- In case of any difficulty faced while registering on BHEL's e-Procurement portal developed by NIC, queries may be addressed to 0120-4001002, 0120-4001005 and 0120-6277787; email: support-eproc@nic.in. These details are also available on 'Contact Us' page of the portal.
- Before uploading scanned documents if any, the bidders shall sign on all the statements, documents, certificates uploaded by him, owning responsibility for their correctness / authenticity.
- Disclaimer clause:** Neither the Organization (Bharat Heavy Electricals Ltd.) nor the service provider is responsible for any failure of submission of bids due to failure of internet or other connectivity problems or reasons thereof.

2. SCOPE OF SUPPLY

Material shall be supplied as per the applicable latest Technical Delivery Conditions (TDC)/ Material Standard requirements/BPS/Drawing and other requirement as given in the Tender Enquiry. National





General Contract Conditions (GCC) of MM Tenders

BHARAT HEAVY ELECTRICALS LIMITED

Industrial Valve Plant: 433, Industrial Complex,
Goindwal Sahib, Dist. Tarn Taran,
Punjab-143422 (INDIA)

& International material Standards shall have to be arranged by vendors themselves. Latest applicable revisions of standards/procedures to be referred.

All required tests as called in referred material standard/BHEL/TDC/drawing etc. shall be carried out by vendor at no extra cost. Material Test Certificates (MTC), inspection reports and Compliance/Guarantee Certificate are to be provided along with the supplies.

3. PRICE BASIS

1. Order of enquiry item sl. no. shall be maintained in the quotation.
2. The rates quoted shall be firm and fixed. No price variation is proposed and allowed.
3. Rates quoted should be FOR BHEL Goindwal basis. The offers quoted on other than FOR Goindwal basis are liable to be rejected.

In case bidder has quoted Ex-works prices, then he/she will be given an opportunity to accept price basis as FOR Goindwal either by accepting delivery as FOR Goindwal in same quoted price or by providing loading factor on his/her quoted ex-works prices to make them FOR prices.

Variation in GST or any other statutory levies during contractual delivery period shall be to BHEL's account.

4. DISCREPANCY IN WORDS AND FIGURES

1. If, in the price structure quoted for the required goods/ services/ works, there is discrepancy between the unit price and the total price (which is obtained by multiplying the unit price by the quantity}, the unit price shall prevail and the total price corrected accordingly, unless in the opinion of the purchaser there is an obvious misplacement of the decimal point in the unit price, in which case the total price as quoted shall govern and the unit price corrected accordingly.
2. If there is an error in a total corresponding to the addition or subtraction of subtotals, the subtotals shall prevail and the total shall be corrected; and
3. If there is a discrepancy between words and figures, the amount in words shall prevail, unless the amount expressed in words is related to an arithmetic error, in which case the amount in figures shall prevail subject of (a) and (b) above.
4. If there is such discrepancy in an offer, the same shall be conveyed to the bidder with target date upto which the bidder has to send his acceptance on the above lines and if the bidder does not agree to the decision of the purchaser, the bid is liable to be ignored.
5. Bids should be free from correction, overwriting, using corrective fluid, etc. Any interlineation, cutting, erasure or overwriting shall be valid only if they are attested under full signature(s) of person(s) signing the bid else shall be liable for rejection.
6. All overwriting/cutting, etc will be numbered by bid opening officials and announced during bid opening.

5. EVALUATION IN CASE OF MORE THAN ONE L-1 BIDDER

In the course of evaluation, if more than one bidder happens to occupy L1 status, effective L1 will be decided by soliciting discounts from the respective L1 bidders.





General Contract Conditions (GCC) of MM Tenders

BHARAT HEAVY ELECTRICALS LIMITED

Industrial Valve Plant: 433, Industrial Complex,
Goindwal Sahib, Dist. Tarn Taran,
Punjab-143422 (INDIA)

In case more than one bidder happens to occupy the L1 status even after soliciting discounts, the L1 bidder shall be decided by a toss / draw of lots, in the presence of the respective L1 bidder(s) or their representative(s).

Ranking will be done accordingly. BHEL's decision in such situations shall be final and binding.

6. REVERSE AUCTION

In case, it is declared in special terms & conditions of tender enquiry that RA is applicable for the NIT, then RA will be conducted as per following clause:

BHEL shall be resorting to Reverse Auction (RA) (Guidelines as available on <https://www.bhel.com/>) for this tender. RA shall be conducted among the techno-commercially qualified bidders as per RA guidelines.

Price bids of all techno-commercially qualified bidders shall be opened and same shall be considered for RA. In case any bidder(s) do(es) not participate in online Reverse Auction, their sealed envelope price bid along with applicable loading, if any, shall be considered for ranking.

7. VALIDITY OF OFFERS

The offers shall be kept open for acceptance 'for number of days mentioned in special terms and conditions' from the date of opening of the tender. In case of tender extension, the bid validity shall be considered from the date of tender opening.

8. SUPPLIED MATERIAL ADJUSTMENT

Item/s pending in previous PO has to be billed in previous PO only. Otherwise, BHEL will be free to adjust the supplies in previous PO. Any implication of tax will be on supplier's account. For this it is desirable that vendor should reconcile the pending PO statement every month/frequently with BHEL. Vendor can also view these details at Portal (<https://trichy.bhel.com/mm/index.jsp>).

9. DELIVERY SCHEDULE

Supplies shall be affected and completed as per schedule mentioned in special terms and conditions. **Further, BHEL may release delivery schedule from time to time based upon our requirement with mutual understanding.** Vendor shall be required to complete the order as per the BHEL schedule requested. Commencement of delivery period shall be reckoned from the date of PO / LOI or any other agreed milestone.

10. LIQUIDATED DAMAGES (LD) FOR LATE DELIVERY

Time is the essence of the contract'. As such, delivery of goods specified in the Purchase Orders released under the scope of this contract shall be made within the time limit prescribed therein. Penalty for late delivery will be applicable @0.5% of the undelivered portion per week of the delay or part thereof subject to a maximum of 10% of the undelivered portion.





General Contract Conditions (GCC) of MM Tenders

BHARAT HEAVY ELECTRICALS LIMITED

Industrial Valve Plant: 433, Industrial Complex,
Goindwal Sahib, Dist. Tarn Taran,
Punjab-143422 (INDIA)

In case of Ex-works delivery terms for indigenous supplies, the document date (Invoice/Challan date) in Goods Receipt (GR) document shall be reckoned for LD deduction. In case of FOR Delivery terms for Indigenous supplies, the posting date in GR document shall be reckoned for LD deduction.

If any vendor does not accept LD ½% of the supply for each week of delay subject to a maximum of 5%, their offer is likely to be rejected by BHEL and the price bid shall not be opened. Bidders accepting for 10% LD shall not be loaded on account of LD. However, bidders who offer any other % LD [between 5% to 10%] shall be loaded @ % deviation from 10% and their accepted %. e.g. If a bidder accepts for a max of 7% LD only, their offer would be loaded @ 3% (10 – 7 = 3).

BHEL reserves the right to receive or not receive the material after the due date of PO. Applicable GST shall also be recovered from suppliers/contractors on LD amount. For this Debit note will be issued by BHEL indicating the respective supply invoice number.

11. PAYMENT TERMS

1. Due payment against supplies received shall be due after 30 days of receipt and acceptance of material and shall be paid within next 15 days' period. In case of any deviation from standard payment term mentioned, BHEL at its discretion may load on the item price at 'Base rate of SBI (as applicable on the date of bid opening; Techno-commercial bid opening) + 6% shall be considered for loading for the period of relaxation sought by bidders.
2. Documents to be submitted (if applicable)
 - i) Tax invoice (Invoice shall be GST compliant and should contains all the required information such as GST No, HSN code etc.)
 - ii) Transporter copy along with material/consignment.
 - iii) Material Test Certificates (MTC) and
 - iv) Compliance Certificate.
3. GST registration number is to be submitted by qualified vendor as per GST law.
4. It is mandatory to mention proper material codes in the invoices and separate invoices to be raised for different POs.
5. **BHEL releases payment through EFT mode ONLY. Necessary details may please be submitted by filling required format before release of payment.**

12. TAXES & DUTIES

Payment of GST portion will be released to vendor only upon completion of statutory requirement and further subject to following:

- a) Vendor declaring such invoice in his GSTR-1 and
- b) Receipt of goods and Tax invoice by BHEL and
- c) Confirmation of payment of GST thereon by vendor on GSTN portal.
- d) Above is subject to receipt of goods/service and tax invoice thereof along with vendor declaring invoice in his return and paying GST within timeline prescribed for availing ITC by BHEL.

Following may please be noted for availing Input Tax Credit (ITC) by BHEL:





General Contract Conditions (GCC) of MM Tenders

BHARAT HEAVY ELECTRICALS LIMITED

Industrial Valve Plant: 433, Industrial Complex,
Goindwal Sahib, Dist. Tarn Taran,
Punjab-143422 (INDIA)

1. Since ITC can be availed only when BHEL is in possession of GST Tax invoice and after receipt of goods. Thus, vendor to ensure timely dispatch of goods and Tax invoice. It may be noted that in case of any delay in receipt of Tax Invoice and/or receipt of goods, the ITC availment by BHEL will get delayed thus entailing additional cash outflow & may even get denied if ITC availment timelines are breached.
2. Further ITC can be availed only when vendor has declared such invoice in his outward supply Return GSTR-1 and after GST thereon has been paid by him at the time of filing of monthly Return.
3. If GST credit is delayed/denied to BHEL due to non/delayed receipt of goods and/or tax invoice or expiry of timeline prescribed in GST law for availing such ITC, or any other reasons not attributable to BHEL, GST amount shall be recoverable from vendor along with interest levied/leviable on BHEL.
4. Further, in case vendor delays declaring such invoice in his return and GST credit availed by BHEL is denied or reversed subsequently as per GST law, GST amount paid by BHEL towards such ITC reversal as per GST law shall be recoverable from vendor/contractor along with interest levied/leviable on BHEL.

13. LIABILITY UNDER REVERSE CHARGE (RCM)

Any GST liability arising on BHEL under Reverse Charge (RCM) before actual receipt of goods and/or Invoice thereof would be subject to recovery of Interest leviable for the period between the date of such liability and actual date of eligibility of ITC based on receipt of goods, receipt of Invoices and other conditions specified in GST Law as applicable.

14. ACCESS TO MANUFACTURING PREMISES

While Purchase Orders placed on the vendor are under execution, authorized representatives of BHEL shall be allowed free access to the manufacturing facilities for the purpose of inspection or monitoring the progress of purchase orders. This access will also be extended to representatives of BHEL's customers accompanying the authorized representative/s of BHEL (which shall be intimated in advance), if our contractual requirements with our customers call for the same.

15. INSPECTION

1. The seller shall give adequate notice, of 1 week or as mutually agreed period, in writing to the Purchaser about the date and place at which the goods will be ready for inspection/ testing, as provided for in the contract.
2. Purchaser or his authorized representative shall be entitled to carry out inspection of material and workmanship/Surveillance Audit at Seller's premises or at his sub-contractor's premises at all reasonable times during execution of contract; Such inspection, examination and testing, if made, shall not absolve the Seller from his obligations under the contract. No additional charges shall be claimed for such inspections. Moreover, all required infrastructure (testing, tools etc) have to be arranged by supplier.
3. Any inspection carried out before supply by vendor/incoming stage at BHEL notwithstanding, if any defect/non-conformity is noted during processing, the same shall be attended/replaced by vendor at no extra cost.
4. BHEL representative from unit or CQ is authorized to carry out audits along with TPIA at vendor's works before clearing the items for dispatch.





General Contract Conditions (GCC) of MM Tenders

BHARAT HEAVY ELECTRICALS LIMITED

Industrial Valve Plant: 433, Industrial Complex,
Goindwal Sahib, Dist. Tarn Taran,
Punjab-143422 (INDIA)

5. Necessary tooling including thread gauges etc. have to be arranged by vendor. Only in exceptional cases, based on BHEL discretions item/nature, BHEL may consider request to provide gauges if available with BHEL. But in no case this shall be linked with delivery of material.

16. GUARANTEE / WARRANTEE AND CORRESPONDING REPAIR / REPLACEMENT OF GOODS

Goods shall comply with the specifications for material, workmanship and performance. Unless otherwise specified, vendor shall give a guarantee / warrantee for a period of 18 months from the date of receipt. In case of non-acceptance of this term, bid shall be liable for rejection.

If the delivery is found non-compliant during the warranty period, leading to rejection, the Seller shall arrange free replacement / repair of goods, within one month from the date of intimation or any mutually agreed period. Corresponding quantity shall be treated as unsupplied against respective purchase order till replacement is received at BHEL.. In the event of the Seller's failure to comply, Purchaser may take action as appropriate, including repair / replenish rejected goods, at the risk & cost of the Seller.

Lifting of rejected material is under Supplier's scope. BHEL will inform related invoice, quantity etc. to supplier. Supplier has to give advance intimation / plan (Transporter, Vehicle details) for the lifting of material. Further supplier has to provide requisite documents (such as Credit Note, e-Way Bill etc.) to lift the rejected material. Material should be lifted within one month from date of intimation. After one-month, BHEL will not be responsible for rejected material and BHEL shall have the right to dispose off such rejected material.

17. LOI (LETTER OF INTENT)

BHEL may issue LOI prior to the PO for any reason whatsoever. The LOI in such cases is to be treated as PO for all practical purposes and all the Terms & Conditions of the tender shall be applicable from the date of issue of LOI.

18. SUB-CONTRACT

The purchase order or any part thereof shall not be sub-contracted, assigned or otherwise transferred without previously obtaining the BHEL's consent in writing.

19. RISK PURCHASE

Risk & Cost Clause, in line with Conditions of PO may be invoked in any of the following cases:

- i) Supplier's poor progress of the supply vis-à-vis delivery/execution timeline as stipulated in the Contract, backlog attributable to supplier including unexecuted portion of supply that does not appear to be executable within balance available period
- ii) Withdrawal from or abandonment of the supply by contractor before completion as per contract.
- iii) Non-supply by the Supplier within scheduled completion/delivery period as per Contract or as extended from time to time, for the reasons attributable to the supplier.





General Contract Conditions (GCC) of MM Tenders

BHARAT HEAVY ELECTRICALS LIMITED

Industrial Valve Plant: 433, Industrial Complex,
Goindwal Sahib, Dist. Tarn Taran,
Punjab-143422 (INDIA)

- iv) Termination of Contract on account of any other reason (s) attributable to Supplier.
- v) Assignment, transfer, subletting of Contract without BHEL's written permission resulting in termination of Contract or part thereof by BHEL.
- vi) Non-compliance to any contractual condition or any other default attributable to Supplier.

The value shall be calculated as follows:

$$\text{Risk \& Cost Amount} = [(A-B) + (A \times H/100)]$$

Where,

A= Value of Balance scope of Supply (*) as per rates of new contract

B= Value of Balance scope of Supply (*) as per rates of old contract being paid to the supplier at the time of termination of contract i.e. inclusive of PVC, if any.

H = Overhead Factor shall be taken as 5

In case (A-B) is less than 0 (zero), value of (A-B) shall be taken as 0 (zero).

*** Balance Scope of Supply:** Difference of Contract Quantities and Executed Quantities as on the date of issue of Letter for 'Termination of Contract', shall be taken as balance scope of Supply for calculating risk & cost amount.

Contract quantities are the quantities as per original contract. If, Contract has been amended, quantities as per amended Contract shall be considered as Contract Quantities.

Recoveries from the supplier on whom Risk & Cost has been invoked shall be made from following:

- (i) Dues available in the form of Bills payable to supplier, SD, BGs against the same contract.
- (ii) Dues payable to supplier against other contracts in the same Unit of BHEL.
- (iii) Dues payable to supplier against other contracts in the different Regions / Units of BHEL.
- (iv) Legal options for recovery of dues payable by the supplier.

20. FORCE MAJEURE

If at any time during the continuance of the contract, the performance in which or in any part by either party of any obligations under the contract are prevented or delayed by reason of any war, hostilities, acts of public enemy, civil commotion, sabotage, fires, explosions, epidemics, quarantine restrictions, or acts of God (hereinafter referred to "an events" then provided the notice of happening of any such event is given by either party to the other within 21 days of the occurrence thereof, neither party shall by reason of such event be entitled to terminate the contract nor shall either party have any claim for damages against the other in respect of such non-performance and delay in performance and delivery under the contract shall be resumed as soon as practicable after such event has come to an end or ceased to exist. If the performance in whole or part of any obligation under the contract is prevented or delayed by reason of any such event, claims of extension of time shall be granted for periods considered reasonable by BHEL subject to prior notification by the vendor to BHEL of the particulars of the event and supply to BHEL, if required, of any supporting evidence. Any waiver of time in respect of partial installment shall not be deemed a waiver of time in respect of remaining deliveries.





General Contract Conditions (GCC) of MM Tenders

BHARAT HEAVY ELECTRICALS LIMITED

Industrial Valve Plant: 433, Industrial Complex,
Goindwal Sahib, Dist. Tarn Taran,
Punjab-143422 (INDIA)

21. NON-DISCLOSURE AGREEMENT

All Drawing and technical documents relating to the product or it's manufacture submitted by one party to the other, prior or subsequent to the formation of contract, shall remain property of the submitting party. Drawing, technical documents or other technical information received by one party, shall not without the consent of the other party, be used for any other purpose than that, for which they were provided. Such technical information shall not without the consent of the submitting party, otherwise be used or copied, reproduced, transmitted or communicated to a third party. Patterns supplied by BHEL will remain BHEL's property which shall be returned by the bidder on demand to BHEL. Bidder shall in no way share or use such intellectual property of BHEL to promote his own business with others. ***BHEL reserves the right to claim damages from the bidder, or take appropriate penal action as deemed fit against the bidder, for any infringement of the provisions contained herein.***

22. CLARIFICATIONS

The correspondence exchanged against the tender from both tenderer and BHEL through email/e-procurement are considered as valid document legally though it is not signed. It is treated as valid confirmations made on behalf of the respective company and very much comes under the legal ambit of the business transaction and hence it is binding on both the parties to the business. Any transaction pertaining to the tender from both the parties of business done round the clock irrespective of the office or business hours of the companies, are valid legally and binding on both the parties. This applies to the extent only in such cases where deadline time for transaction is not specifically declared by either or both the parties to the business.

23. PREFERENCES FOR MICRO AND SMALL ENTERPRISES (MSEs)

Preferences as mentioned in “Public Procurement Policy for Micro and Small Enterprises (MSEs) Order, 2012” & “Public Procurement Policy for Micro and Small Enterprises (MSEs) Amendment Order, 2018”, or as per latest guidelines issued by government shall be given to Micro and Small enterprises.

Main points which are mentioned in the above orders are as follows:

- 25% Procurement of the tender value shall be made from MSE (Micro, Small Enterprises) firms.
- 25% of the 25% quantity (i.e. 6.25% of the tender quantity) offered to the MSE's shall be reserved for MSE's owned by SC/STs. Failure to participate by any MSE owned by SC/ST's; this 6.25% quantity shall be procured from other MSEs.
- 3% from within the 25% quantity offered to the MSE's shall be reserved for women owned MSE's. Failure to participate by any MSE owned by women; this 3% quantity shall be procured from other MSEs.
- EMD shall be exempted for MSE's. All these benefits are subject to production of all statutory documents





General Contract Conditions (GCC) of MM Tenders

BHARAT HEAVY ELECTRICALS LIMITED

Industrial Valve Plant: 433, Industrial Complex,
Goindwal Sahib, Dist. Tarn Taran,
Punjab-143422 (INDIA)

- In tender, participating Micro and Small Enterprises quoting price within price band of L1+15 per cent shall also be allowed to supply a portion of requirement by bringing down their price to L1 price in a situation where L1 price is from someone other than a Micro and Small Enterprise and such Micro and Small Enterprise shall be allowed to supply up to 25 per cent of total tendered value. In case of more than one such Micro and Small Enterprise, the supply shall be shared proportionately (to tendered quantity).

MSE suppliers can avail the intended benefits only if they submit **Udyam Registration Certificate** along with the offer. No other document shall be considered for availing MSE benefits. Non-submission of such document will lead to consideration of their bid at par with other bidders. No benefit shall be applicable for this enquiry if any deficiency in the above required documents is not cleared before price bid opening. If the tender is to be submitted through e-procurement portal, then the above required document is to be uploaded on the portal.

Note: It may however be noted that MSE guidelines as on date (Date of Technical Bid Opening Part-I) shall prevail.

24. PREFERENCE TO MAKE IN INDIA

This procurement shall be governed by notification no. P-45021/2/2017-PP (BE-II) dated 16.09.2020 of Government of India issued by DPIIT and subsequent circulars issued afterwards. Accordingly, the minimum local content, the margin of purchase preference and the procedure for purchase preference to make in India shall be adhered.

25. RESTRICTIONS UNDER RULE 144(XI) OF THE GENERAL FINANCIAL RULES (GFRs), 2017

All provisions of Order No. F.No.6/18/2019-PPD of Department of Expenditure (DoE) shall be applicable for this tender enquiry (Order copy is available at <https://doe.gov.in/procurementpolicy-divisions>). Accordingly, any bidder from a country which shares a land border with India (except the countries to which the Govt. of India has extended lines of credit or in which the Govt. of India is engaged in development projects for which list is available at <https://www.mea.gov.in/>) will be eligible to bid in this tender only if the bidder is registered with the Competent Authority as specified in Annex I of the said Order of DoE.

Updated list of the countries to which lines of credit have been extended or in which development projects are undertaken are available on the Ministry of External affairs website (<https://www.mea.gov.in/>)

For the purpose of this order, definition of Bidder from a country which shares a land border with India shall be same as defined in the Annex III of the said order.

Registration with the competent authority as stipulated in the said order is responsibility of bidder. **Bidder has to submit a certificate certifying following along with offer:**

"I have read the clause regarding restrictions on procurement from a bidder of a country which shares a land border with India; I certify that this bidder is not from such a country or, if from such a country,





General Contract Conditions (GCC) of MM Tenders

BHARAT HEAVY ELECTRICALS LIMITED

Industrial Valve Plant: 433, Industrial Complex,
Goindwal Sahib, Dist. Tarn Taran,
Punjab-143422 (INDIA)

has been registered with the Competent Authority. I hereby certify that this bidder fulfils all requirements in this regard and is eligible to be considered. [*Where applicable, evidence of valid registration by the Competent Authority shall be Attached*].”

26. DISPUTES

In the event of any dispute and/or difference arising between the Vendor and BHEL as to interpretation and/or execution of the contract and/or the respective rights and liabilities of the parties, such disputes and/or differences shall be referred to the sole arbitrator nominated by BHEL. The provisions of the Indian Arbitration Act and the rules there under shall apply to such arbitration. The award passed by the arbitrator shall be final and conclusively binding on all the parties.

27. JURISDICTION

The court of the place from where the purchase order is issued shall alone have jurisdiction to decide any dispute arising out of or in connection with the purchase order.

28. BANNED FIRMS

The offers of the bidders who are on the banned list as also the offer of the bidders, who engage in the services of the banned firms, shall be rejected. The list of banned firms is available on BHEL website <https://www.bhel.com/>.

29. FRAUD PREVENTION POLICY

The Bidder along with its associate / collaborators / sub-contractors / sub-vendors / consultants / service providers shall strictly adhere to BHEL Fraud Prevention Policy displayed on BHEL website <https://www.bhel.com/> and shall immediately bring to the notice of BHEL management about any fraud or suspected fraud as soon as it comes to their notice.

30. PREVENTIVE CHECKS TO ELIMINATE SUSPECTED CARTEL FORMATION

The Bidder declares that they will not enter into any illegal or undisclosed agreement or understanding, whether formal or informal with other Bidder(s). This applies in particular to prices, specifications, certifications, subsidiary contracts, submission or non-submission of bids or any other actions to restrict competitiveness or to introduce cartelization in the bidding process. In case, the Bidder is found having indulged in above activities, suitable action shall be taken by BHEL as per extant policies/ guidelines.

31. SUSPENSION OF BUSINESS DEALINGS WITH DEFAULTERS

The offers of the bidders who are under suspension as also the offers of the bidders, who engage the services of the banned firms, shall be rejected. The list of banned firms is available on BHEL web site <https://www.bhel.com/>.

1.0 Integrity commitment, performance of the contract and punitive action thereof:

1.1. Commitment by BHEL:





General Contract Conditions (GCC) of MM Tenders

BHARAT HEAVY ELECTRICALS LIMITED

Industrial Valve Plant: 433, Industrial Complex,
Goindwal Sahib, Dist. Tarn Taran,
Punjab-143422 (INDIA)

BHEL commits to take all measures necessary to prevent corruption in connection with the tender process and execution of the contract. BHEL will during the tender process treat all Bidder(s) in a transparent and fair manner, and with equity.

1.2. Commitment by Bidder/ Supplier/ Contractor:

1.2.1. The bidder/ supplier/ contractor commits to take all measures to prevent corruption and will not directly or indirectly influence any decision or benefit which he is not legally entitled to nor will act or omit in any manner which tantamount to an offence punishable under any provision of the Indian Penal Code, 1860 or any other law in force in India.

1.2.2. The bidder/ supplier/ contractor will, when presenting his bid, disclose any and all payments he has made, and is committed to or intends to make to agents, brokers or any other intermediaries in connection with the award of the contract and shall adhere to relevant guidelines issued from time to time by Govt. of India/ BHEL.

1.2.3. The bidder/ supplier/ contractor will perform/ execute the contract as per the contract terms & conditions and will not default without any reasonable cause, which causes loss of business/ money/ reputation, to BHEL.

If any bidder/ supplier/ contractor during pre-tendering/ tendering/ post tendering/ award/ execution/ post-execution stage indulges in mal-practices, cheating, bribery, fraud or and other misconduct or formation of cartel so as to influence the bidding process or influence the price or acts or omits in any manner which tantamount to an offence punishable under any provision of the Indian Penal Code, 1860 or any other law in force in India, then, action may be taken against such bidder/ supplier/ contractor as per extant guidelines of the company available on <https://www.bhel.com/> and/or under applicable legal provisions

32. GENERAL

1. BHEL will not be bound by any power of attorney granted by the vendors or by changes in the composition of the firm made subsequent to the execution of the contract. They may, however, recognize such power of attorney and changes after obtaining proper legal advice, the cost of which will be chargeable to the vendor concerned.
2. BHEL reserves the right to extend the due date of opening, which shall be informed. Validity of offer shall be deemed to be revised accordingly.
3. BHEL reserves the right to accept or reject any part or whole of the tender of a bidder by assigning a valid reason thereof. BHEL reserves the right to cancel the tender without assigning any reason thereof and without any obligation before any commitment.
4. Acceptance of all terms and conditions, in the form of signed copy of T&C or confirmation separately written, shall be submitted along with quotation. If nothing is mentioned, it shall be concluded that terms and conditions are acceptable.
5. BHEL may increase/decrease item/s based on BHEL requirement before price bid opening. Suitable price implication may be asked from suppliers.
6. BHEL may drop item/items from tender at any stage of tender before placing PO. BHEL may also delete PO with consent with supplier within delivery date of PO.





General Contract Conditions (GCC) of MM Tenders

BHARAT HEAVY ELECTRICALS LIMITED

Industrial Valve Plant: 433, Industrial Complex,
Goindwal Sahib, Dist. Tarn Taran,
Punjab-143422 (INDIA)

7. After releasing PO, it is assumed that supplier has accepted PO if we do not receive acknowledgement from supplier within 5 days of date of PO.
8. In case of unscheduled holiday on opening day of tender, the next working day will be treated as scheduled prescribed day of opening of tender.
9. On the due date of tender opening, only technical bids will be opened. The opened technical bids will be evaluated by us and clarifications required, if any, will be called for from the bidders on technical and commercial points. If no reply is received from the vendor for the clarification raised by BHEL with in the final cut-off date, those vendors offer will be processed with the documents available / submitted against this tender. Offers not meeting the required specification and technical condition will be summarily rejected. The price bids of technically suitable bidders will be opened on a later date with prior intimation to techno-commercially suitable bidders.
10. Ranking L-1, L-2 etc. shall be done for individual item for the techno-commercially acceptable offers on landed cost to BHEL, IVP Goindwal basis and BHEL reserves the right to place order for individual items with different vendors.
11. BHEL reserves the right to negotiate with L1 vendor or re-float the tender for items where, L1 price is not the lowest acceptable price; BHEL reserves the right to increase or decrease the tender quantity.
12. If supplier is mentioning delivery destination within state/ outside state depending upon his location of factory, Free on Road etc. these are assumed as on FOR Goindwal. If supplier is wishing to give delivery on Ex works basis, then he has to clearly mention about it.
13. The bidder has to keep track of any changes by viewing the addendum(s) / Corrigendum(s) issued by the Purchaser on time-to- time basis in the E-Procurement platform. The Company calling for tenders shall not be responsible for any claims/problems arising out of this.
14. Unregistered suppliers, who are techno-commercially qualified against the open tender, are requested to register with BHEL as permanent supplier by submitting the Supplier Registration Form (SRF). SRF is available at <https://www.bhel.com/supplier-registration>.
15. Any term in special tender terms and conditions will supersede the GCC.



DRAWING NO.

SECTION - PP

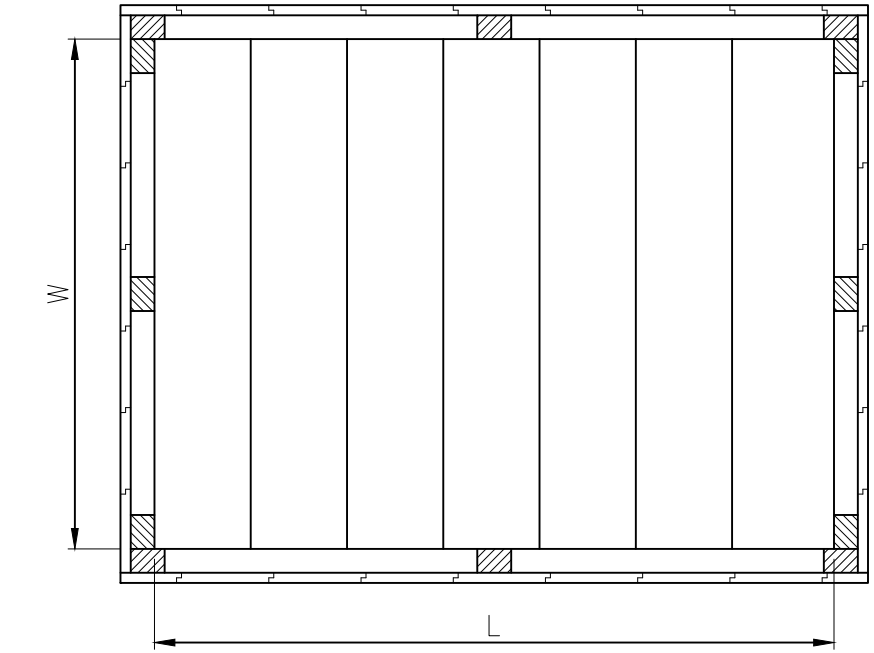
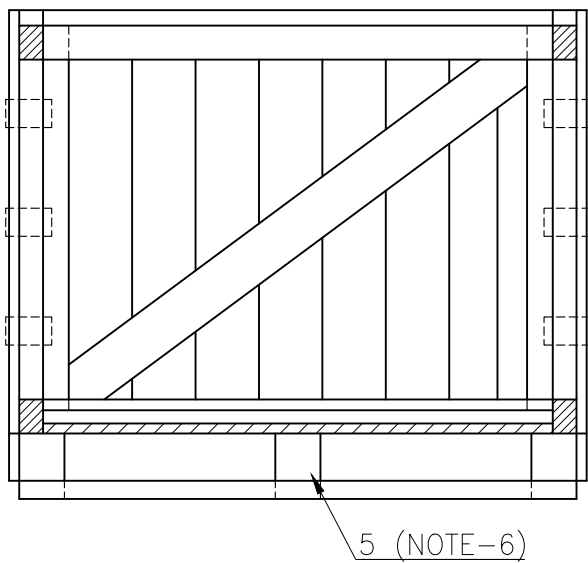
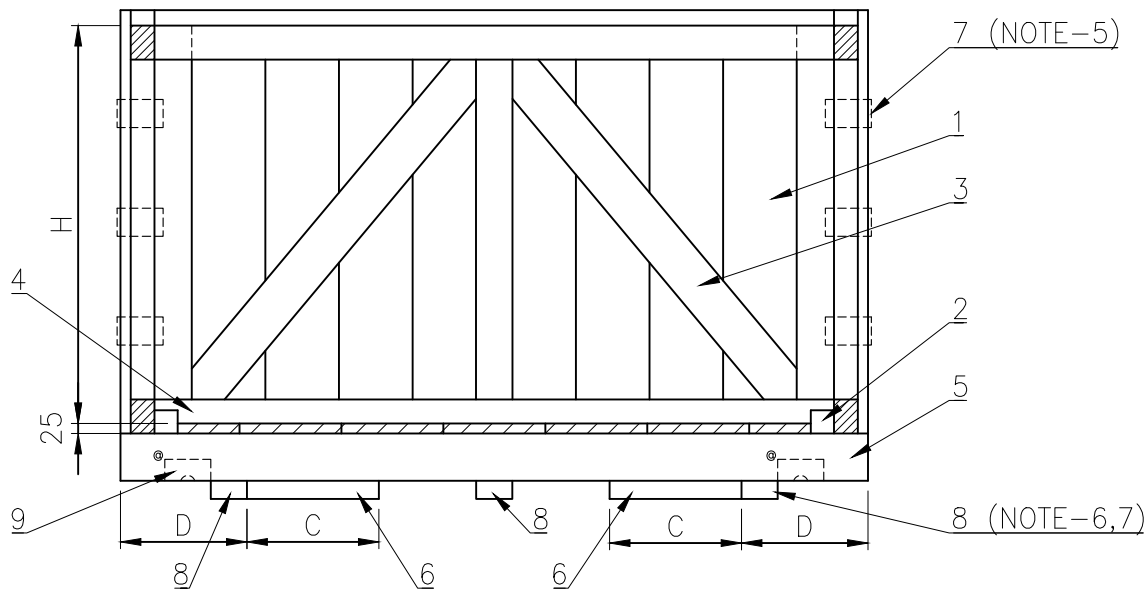
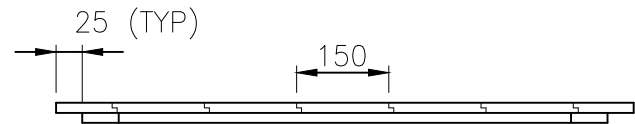
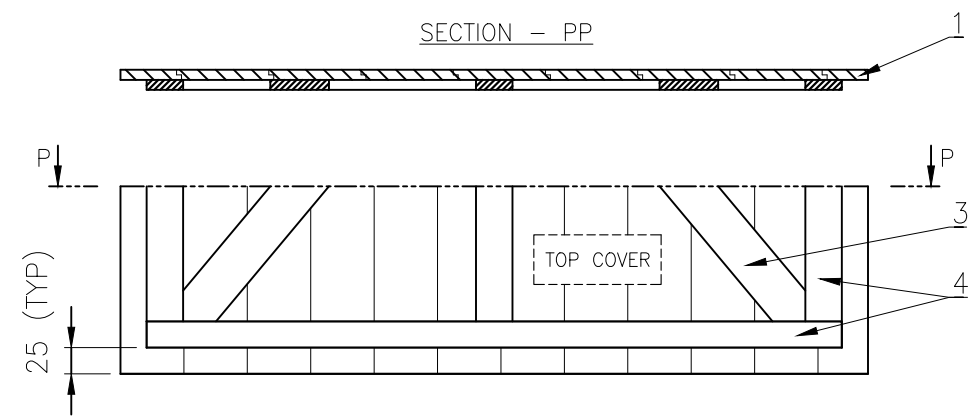

NOTES:

1. TO AVOID RAIN WATER ENTRY, THE INSIDE OF ALL SIDES EXCEPT BOTTOM SHALL BE FULLY COVERED BY POLYTHENE FILM (REFER LATEST APPLICABLE TDC).
2. SECURE THE ASSEMBLIES WITH ENOUGH SIDE SUPPORTS TO AVOID MOVEMENT OF ASSEMBLIES DURING TRANSIT.
3. PLANK SIZE: 20X150 MM FOR S.NO. 1 TO 7
25X150 MM FOR S.NO. 8 TO 17.
4. FOR S.NO. 1 TO 5, ITEM-6 IS CONTINUOUS.
5. ITEM-7 IS 2 NOS. (FOR S.NO. 1 TO 9) AND 3 NOS. (FOR S.NO. 10 TO 17) AT EACH VERTICAL CORNER.
6. CENTER RUNNER AND ITEM-8 ARE APPLICABLE FOR S.NO. 12, 13, 14, 15, 16, 17 ONLY.
7. FOR S.NO. 17, 04 NOS. OF ITEM-8 WITH EQUAL SPACING TO BE USED.

S.NO.	MATERIAL	BOX TYPE	DIMENSIONS				
			L	W	H	C	D
1	GWB67035003	3A	670	670	500	-	200
2	GWB67035004	4	710	630	600	-	200
3	GWB67035005	5	850	630	670	-	200
4	GWB67035006	6	1000	770	670	-	200
5	GWB67035007	7	1100	430	670	-	200
6	GWB67035008	9A	1250	570	710	300	200
7	GWB67035009	10A	1300	770	850	300	200
8	GWB67035010	13A	1500	650	710	300	200
9	GWB67035011	14A	1850	700	710	300	200
10	GWB67035012	14B	1850	700	1050	300	200
11	GWB67035013	15	2000	800	800	400	200
12	GWB67035014	16	2134	915	1220	400	250
13	GWB67035015	16A	2743	1220	1070	400	250*
14	GWB67035044	16C	2520	1210	1320	400	250
15	GWB67035047	16B	2743	1220	1525	400	250
16	GWB67035051	16D	2743	1400	1525	400	250
17	GWB67035052	17	4200	1420	1525	500	300

ITEM NO.	DESCRIPTION	SIZE (mm)	MATERIAL
1	SOFT WOOD PLANK	NOTE-3	WOOD
2	END TRAVERSE BAR	50 X 50	WOOD
3	DIAGONAL BRACE	75 X 25	WOOD
4	SOFT WOOD BATTERNS	75 X 25	WOOD
5	RUNNER	100 X 100	WOOD
6	RESTING BEAM	100 X 50	WOOD
7	SIDE PLATE	100 x 150 x1.5	M.S. SHEET
8	CROSS BEAM	100 x 50	WOOD
9	SLING PLATE	100 x 150 x1 #	M.S. SHEET

REV	DATE	ALTERED	REV	DATE	ALTERED	REV	DATE	ALTERED	REV	DATE	ALTERED	REV	DATE	ALTERED	REV	DATE	ALTERED
		CHD & APPD			CHD & APPD			CHD & APPD			CHD & APPD			CHD & APPD			CHD & APPD
				17.08.20	S.NO. 16, 17 ADDED.		13.03.20	© ITEM-9, LOCATION MODIFIED.		22.08.18	# FOR ITEM-9, THICKNESS 1 WAS 1.5.						
					NOTE-7 ADDED.			FOR SL.NO. 12, DIM 250 WAS 200.									

CAUTION: The information on this document is the property of BHARAT HEAVY ELECTRICALS LTD. It must not be used directly or indirectly in any way detrimental to the interest of the company.

SL No.	DESCRIPTION	MATL CODE	MATL SPECN	HEAT TREATMENT	SCRAP SORT	NET WT (kg)	GROSS WT (kg)	DRAWING No	ITEM No
TYPE OF PRODUCT OR NAME OF CUSTOMER/PROJECT CS									
BHARAT HEAVY ELECTRICALS LTD. UNIT: INDUSTRIAL VALVE PLANT. GOINDWAL SAHIB - 143422.				DRN	NAME	SIGN	DATE	NO.OF VAR.	
				CHD	RAVINDER SINGH	R.S.	06.01.14		
				APPD	RAKESH KUMAR	R.K.	06.01.14		
DEPT	SCALE	WEIGHT (KG).	REFERENCE INFORMATIONS						
	NTS								
TITLE PACKING BOX (WOOD)							CARD CODE	DRAWING NO.	REV
							U 01	2-SH-BW-022	15

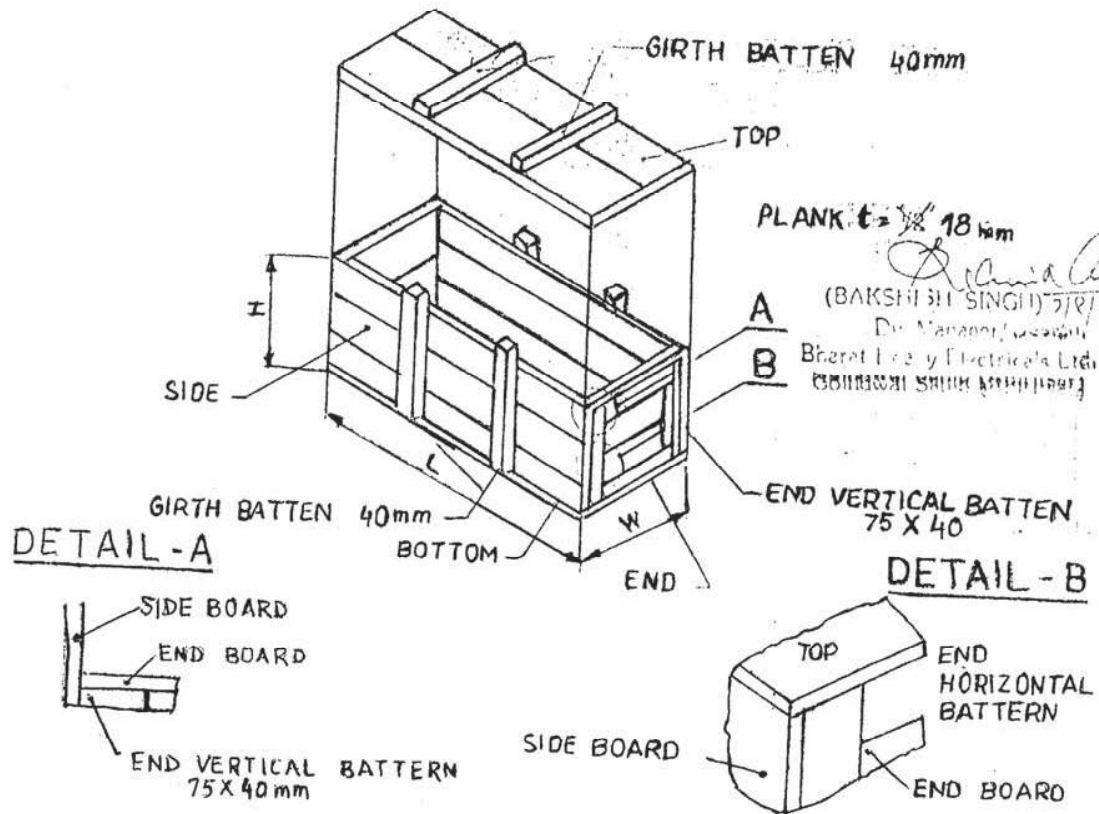

Box Type No 2A is added.
(Signature)
 24/8/2002

TYPE NO				
	L	W	H	
1A	320	250	260	
1	320	250	430	
2	430	370	430	
2A	500	450	550	

NOTES:-

1. ALL DIMENSIONS ARE IN mm.
2. L, W, H ARE INNER DIMENSIONS OF THE BOX.



BHEL –IVP-Goindwal
Quality Department
Technical Delivery Conditions

DOC NO TDC:WOODENBOX:
Rev:06
Rev date: 18.08.2018

Product: : Assembled Wooden boxes and loose wooden planks

1. General:

This TDC lays down instructions for supply of assembled wooden boxes and loose wooden planks at industrial valves plant for transportation of the valves/wall blowers/Loose Components & other finished products.

2. Wood Species:

The following wood species can be used for Wooden boxes/planks:

Coniferous Wood:

Trade Name	Botanical Name
Fir	Abies pindrow
Deodar	Cedrus deodara
Chir	Pinus roxburghil
Kali	Pinus wallichians
Khasi Pine	Pinus khasya
Spruce	Picea smithiana boiss

Non Coniferous Wood:

Trade Name	Botanical Name
Rubber wood	Hevea brasiliensis
Salai	Boswellia serrata
Bahera	Terminalia bellirica
Jaman	Syzygium cumini
Lendi	Lagerstroemia parviflora
Mango	Hangifera indica
Machilus(Kalamavu)	Machilus macrantha
Irul	Xylis xylocarpa
Irulbaken	Hopes
Karumarudu	Terminalia tomentosa
Murtenga	Bursera serrata
Nangal	Mesua ferrea
Pillamarudu	Terminalia panicutala
Sal	Shorea Robusta

Any other species of wood as per Groups I, II of IS 6662 will also be accepted.



BHEL –IVP-Goindwal
Quality Department
Technical Delivery Conditions

DOC NO TDC:WOODENBOX:
Rev:06
Rev date: 18.08.2018

Product: : Assembled Wooden boxes and loose wooden planks

3. Compliance With Standards:

Assistance has been derived from the following standards in the preparation of this specification.

BHEL Corporate Packing Standard No.. : AA 51402 for non-coniferous wood

BHEL Corporate Packing Standard No.. : AA 51401 for coniferous wood

IS 1326-1992: Non-Coniferous Sawn Timber (Baulks & Scantling)

IS 5966-1993: Non-Coniferous Timber in Converted Form for General Purposes

IS: 190 – 1991 Grade I:Coniferous Sawn Timber (Baulks & Scantling)

IS: 6662 – 1993 : Timber Species Suitable For Wooden Packaging Groups I & II

4. Requirements:

- 4.1 Wooden boxes shall be duly provided with a 70 GSM (Colourless/Transparent) Multi Layered Cross Laminated Polythene Film Specification No: AA51420 on inner surface of four sides of box & inner surface of top cover using blue nails to protect the valves from outside rain water or condensing moisture. The length of blue nails shall be 16mm.
- 4.2 Wherever 2 pieces of Cross laminated poly film are used, the joint shall have an overlap of minimum 20 mm. The film used for top cover shall project outside on 4 sides by at least 100 mm and shall be nailed properly on sides. The film is not required for the base of the boxes.
- 4.3 Corner plates and sling plates made of mild steel sheet measuring as per drawing shall be used.
- 4.4 Two consecutive planks shall be joined by lap joint as per drawing.
- 4.5 The dia. of the nails shall be 3.15mm. The length of the nails shall be 65mm wherever two planks of 25mm thickness are joined and 85mm wherever a 25mm planks is joined to a 50mm plank. The extra length of nail after nailing in both planks shall be bend properly. Nailing should be done in such a way that head of nail shall be outside the box. Distance between any two nails shall not be more than 100mm.

5. Dimensions and Tolerances:

Width, thickness and length of all components of wood used in wooden boxes shall be as specified in drawing/Purchase Order. Dimensional tolerances shall be as follows:

Width: +/- 5mm

Thickness : +2/-1 mm (for thickness less than 20 mm)

+3/-1 mm (for thickness \geq 20 mm)

Length: +/- 2% of total length or 25 mm whichever is lower.



BHEL –IVP-Goindwal
Quality Department
Technical Delivery Conditions

DOC NO TDC:WOODENBOX:
Rev:06
Rev date: 18.08.2018

Product: : Assembled Wooden boxes and loose wooden planks

6. Moisture Content:

The timber shall have moisture content as stated below within a depth of 15mm from the surface excluding a length of 300 mm from each end at the time of inspection. The moisture content will be determined in accordance with IS: 287

October to June : 30%
July to September (Rainy season) : 40%.

7. Permissible Defects:

- 7.1 Brushness, splits across the grains, shakes, cups, twist, insect attack, centre heart in planks are the defects which are not acceptable.
- 7.2 **Bow:** Shall be permissible upto a maximum of 2mm for 300mm
- 7.3 **End Splits:** The largest end splits at each end shall be measured and the length added together. The added lengths of these shall not exceed 60 mm per meter run of the piece.
- 7.4 **Live / Dead Knots:** A maximum of 5 Knots/m length are permissible; however, the knots shall not be so grouped or located as to affect the strength of the piece. Knots above 35mm. diameter are not permissible. Major axis of the knot shall be taken as the diameter of this knot.
- 7.5 **Surface Cracks:** Surface cracks with a depth of 10% subjected to maximum of 10 mm are permissible. A continuous crack of any depth all along the length is not permissible.

8. Certificate:

The supplier shall furnish a certificate with each lot/consignment in support of the species of the wood, moisture content, size of the nails used, GSM of polythene used, dimension report of one piece per type per lot and any special information which the tenderer feel is essential for the quality of the packing boxes.

9. Identification and Marking:

The boxes shall be marked/painted in order to identify the source of supply on one of two small side faces.

- SUPPLIER NAME:
- BOX TYPE:
- BOX SERIAL NO.:
- SUPPLIER INVOICE NO.:

Following marking has to be done using paint/ink & stencil on one long side face-

- CONSIGNEE :
- INVOICE NO.:
- OA NO./WO. NO.:



BHEL –IVP-Goindwal
Quality Department
Technical Delivery Conditions

DOC NO TDC:WOODENBOX:
Rev:06
Rev date: 18.08.2018

Product: : Assembled Wooden boxes and loose wooden planks

- CASE NO.:
- MATERIAL/QTY:
- WEIGHT:
- FROM :BHEL/GOINDWAL/TARN TARAN

The ink shall be non-fading/indelible and non-washable by water.

Loose planks supplied by supplier as per PO shall be done colour coding on one end as per colour allotted to supplier.

10. Inspection: Supplier shall submit inspection report as per below format for one box of each type per lot of supply:

Inspection Format for wooden boxes and planks:									
Date of inspection:					Box inspection format no: Wooden box insp:001				
Supplier name									
Supplied batch details									
Observed dimensions									
Box type	L	W	H	C	D	Dimension	LENGTH	width	Thickness
						Plank			
						Resting Beam			
						others			
SN	Type of check			Remarks					
1	Polythene film								
2	Corner and sling plates								
3	Planks overlapping								
4	Moisture content								
5	Size of nails used								
6	Defect details (If found above permissible limit as per clause No. 7)								
7	Identification and Marking								
8	Other remarks(If any)								







BHEL –IVP-Goindwal
Quality Department
Technical Delivery Conditions

DOC NO TDC:WOODENBOX:
Rev:06
Rev date: 18.08.2018

Product: : Assembled Wooden boxes and loose wooden planks

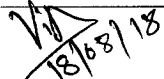
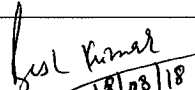
11. AUDIT CHECKS AT BHEL:

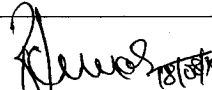
BHEL reserves the right to carry out audit checks for wood species, polythene film confirmation to standard, nails size, Corner & Sling plate material & dimension, planks & overall box dimensions. Items found defective during check at BHEL will be rejected.

 18/08/18	 18/08/18	 20/8/18	 18/08/18	 20/8/18
Vikas Kumar	Rajesh Kumar	Harpreet Rai	Rakesh Kumar	S R Kenny
Sr. Engr/QM	Dy Mgr/CML	Sr DGM/CML	Sr DGM/MM	AGM/QM &HSE
Prepared by		Reviewed by		Approved by

This page intentionally left blank



CORPORATE PURCHASING SPECIFICATION

AA51402

Rev No. 03

PAGE 1 of 5

NON-CONIFEROUS TIMBER FOR GENERAL PACKING PURPOSES

1 GENERAL

This specification governs the quality requirements of Non-Coniferous Timber supplied in the form of planks, battens, beams and sleepers.

2 APPLICATION

Used for general packing purposes.

3 COMPLIANCE WITH NATIONAL STANDARDS

There is no National standard covering this material. However, assistance has been derived from the following National standards:

- IS 1326-1992: Non-Coniferous Sawn Timber (Baulks & Scantling)
- IS 5966-1993: Non-Coniferous Timber in Converted Form for General Purposes
- IS 6662-1993 Groups I & II: Timber Species Suitable For Wooden Packaging

4 TERMINOLOGY

For the purpose of this specification, the definitions given in IS 707 (Glossary of terms applicable to timber and timber products) shall apply except for the beam which is defined as follows:

Beam is defined as converted timber whose cross-sectional dimensions exceed 50mm in both directions.

5 SPECIES

Shall be as stated on the order- Some standard species are:

Trade Name	Botanical Name
Rubber wood	Hevea brasiliensis
Salai	Boswellia serrata
Bahera	Terminalia bellirica
Jaman	Syzygium cumini
Trade Name	Botanical Name
Lendi	Lagerstroemia parviflora
Mango	Hangifera indica
Machilus(Kalamavu)	Machilus macrantha
Irul	Xylis xylocarpa
Irulbaken	Hopes
Karumarudu	Terminalia tomentosa
Murtenga	Bursera serrata
Nangal	Mesua ferrea
Pillamarudu	Terminalia paniculata
Sal	shorea robusta

Revisions:

Clause 6.2.3 of MOM of WG (T&PM)

APPROVED:

INTERPLANT MATERIAL RATIONALISATION COMMITTEE – MRC(T&PM)

Rev No.03	Amd No. 03	Reaffirmed	Prepared HEP, Bhopal	Issued Corp.R&D	Dt. of 1 st Issue 01-03-1980
Dt:01-10-1995	Dt:	Year:2018			



Silver oak	Grevillea robusta
Tada(Dhaman)	Grewia tillifolia

Any other species of wood as per Groups I & II of IS 6662 may also be ordered.

6 DIMENSIONS AND TOLERANCES

6.1 Sizes

Width, thickness and length of timber shall be clearly stated on the order.

6.2 Tolerances

6.2.1 Width: 50 to 250 mm, Tolerance: ± 3 mm

6.2.2 Thickness: 20 to 250 mm, Tolerance: $+3$ mm
 -1 mm

6.2.3 Length

Standard length : 1 to 12 metres in multiples of 0.5 metre

Tolerance : $\pm 2\%$ or ± 25 mm whichever is less.

Note

1) Measurements

1.1) When nominal sizes are ordered, length, width and thickness shall be measured on the basis of accepted sizes. Plus tolerances shall not be added while computing the volume.

1.2) The measurements of length, width, thickness and computation of volume shall be as follows:

- a) The length shall be measured in metres in midline of a piece. The fractions of a metre shall be rounded off to the nearest lower 10 mm.
- b) The width shall be measured at the narrowest place in millimetres and shall be rounded off to the nearest lower one millimetre.
- c) The thickness shall be measured at the narrowest place in millimetres and shall be rounded off to the nearest lower one millimetre.
- d) The volume shall be computed in cubic metres correct to three places of decimal on the basis of accepted sizes.

2) Single sampling plan based on IS 2500 shall be followed.

7 MOISTURE CONTENT

The timber shall have a moisture content as stated below within a depth of 15mm from the surface excluding a length of 300mm from each end at the time of inspection. The moisture content will be determined in accordance with Appendix-A of IS 287.

October to June : 30%

July to September (Rainy season) : 40%

8 FREE FROM DEFECTS

Timber shall be free from the following defects:

Brashness, splits across the grain, shakes, spring, twist, insect attack, any kind of decay (rot), any sign of infection, open centre heart, centre heart on planks and any other defect.

Defects to the extent specified below are permissible. These defects shall be measured in accordance with IS 3364.

8.1 Bow

Shall be permissible upto a maximum of 2mm for 300mm length.



CORPORATE PURCHASING SPECIFICATION

AA51402

Rev No. 03

PAGE 3 of 5

8.2 Wane

- a) For sections upto and including 150 X 150 mm:

Shall be permissible upto 1/5 of the width on the broad face subject to a maximum of 60mm and upto 1/3 of the width on the narrow face subject a maximum of 40mm, provided that one broad face is completely free from this defect. The wane shall be measured at its deepest part.

- b) For sections above 150 X 150 mm

The cumulative lengths of waness on all the sides should not be more than one length of the piece.

8.3 End splits

The longest end split at each end shall be measured and the lengths added together. The total length of these shall not exceed 60mm per metre run of the piece.

8.4 Live knots upto 35mm diameter

A maximum of 5 knots/metre length are permissible. However, the knots shall not be so grouped or located as to affect the strength of the piece.

Live knots above 35mm diameter are not permissible.

8.5 Dead knots

- a) Below 10mm diameter

A maximum of 3 knots/metre length are allowed provided that the knots are not so grouped or located as to affect the strength.

- b) From 10mm to upto and including 25mm diameter

A maximum of 2 knots allowed to the extent of 1 knot/metre length.

- c) Above 25mm diameter

Not allowed.

Note: (For clauses 8.4 & 8.5): Major axis of the knot should be taken as the diameter of the knot.

8.6 Surface cracks

Surface cracks with a depth of 10% subject to a maximum of 10mm are permissible. A continuous crack of any depth all along the length is not permissible.

8.7 Sap wood

Permissible upto a maximum of 12 percent of the cross sectional area.

9 END COATING

Timber shall be coated with any of the following effective compositions upto a distance of 80mm from each end.

9.1 Thick coal tar or bituminous paint.

9.2 Resin and lamp black (10:1) melted, mixed and applied hot.

9.3 Hardened gloss oil.

9.4 Paraffin wax.

9.5 Molasses and lime (3:1).

9.6 Geru/Yellow clay.



10 INSPECTION AT SUPPLIER'S WORKS

Whenever specified, tests and inspection are to be conducted in the presence of BHEL's representative. BHEL representative shall have free access at all times while work on the contract is being performed to all parts of the manufacturer works. The manufacturer shall offer BHEL's representative all reasonable facilities, without charge, to satisfy the latter that the material is being furnished in accordance with this specification.

The manufacturer shall prepare and provide necessary test specimens for testing to be carried out at his premises. If facilities are not available at his works the manufacturer shall make necessary arrangements for carrying out the prescribed tests elsewhere. The manufacturer shall notify BHEL in advance about the readiness of the material for inspection and testing.

BHEL reserves the right to test the material at BHEL's Works and the final, acceptance of the material shall be based on these test results.

11 TEST CERTIFICATES

Three copies of test certificate shall be supplied unless otherwise stated on the order.

In addition, supplier shall ensure to enclose one copy of test certificate along with their dispatch documents to facilitate quick clearance of the material.

The test certificate shall have the following information:

- AA51402, Rev.No.03 : NON-CONIFEROUS TIMBER FOR GENERAL PACKING PURPOSES
- BHEL order No. :
- Supplier's References :
- Type & Specie :
- Treatment, if any :
- Results of Dimensional Inspection :
- Moisture content :
- Defects as per clause 8 :
- Size :
- Quantity supplied :

12 MARKING

The timber shall be marked/painted with the following:

- AA51402
- BHEL order No.
- Supplier's Name
- Size & Quantity

13 REJECTION AND REPLACEMENT

If the material does not conform to the requirements of this specification or found defective during v further processing, such material shall be rejected notwithstanding any previous certification of satisfactory testing and/or inspection. The supplier shall under take to replace the rejected consignment at his own cost and the rejected material shall be taken back by the supplier after fulfilling the commercial terms and conditions.



CORPORATE PURCHASING SPECIFICATION

AA51402

Rev No. 03

PAGE 5 of 5

14 REFERRED STANDARDS

The following is the list of the latest standards, as published by the respective issuing bodies, referred to in this, specification.

- 1) IS 287
- 2) IS 707
- 3) IS 1326
- 4) IS 2500
- 5) IS 3364
- 6) IS 5966
- 7) IS 6662

**MULTILAYERED CROSS LAMINATED POLYETHYLENE FILM****1.0 GENERAL:**

This specification governs the quality requirements of multilayered cross laminated polyethylene film. The cross lamination gives qualities of extra toughness, together With flexibility and lightness coupled with good weather resistance to ultra violet rays.

2.0 APPLICATION:

Used for packing and allied purposes.

3.0 COMPLIANCE WITH NATIONAL STANDARDS:

There is no Indian Standard covering this type of material.

4.0 AVERAGE WEIGHT, DIMENSIONS AND TOLERANCES:**4.1 Average weight & Sizes:**

Average weight (G.S.M), Width and Length shall be as stated on the order.

4.2 Average Weight & Tolerance:

45, 60, 70, 90, 105, 120, 150, 200, & 250 GSM with a tolerance of $\pm 10\%$.

4.3 Width and tolerance:**4.3.1 Preferred widths:**

900, 1000, 1500, 2000, 2500, 3000 and 3660 mm.

4.3.2 Tolerance on width:

Width, mm		Tolerance(\pm) mm
Above	Upto & Includ.	
900	1250	8
1250	2500	20
2500	3000	40
3000	3660	50

Revisions :
As per e-mail dt. 4-08-2008 from Shri.Gopal Bhat,
SDGM, Bhopal

APPROVED:
INTERPLANT MATERIAL RATIONALISATION
COMMITTEE- WG (T&PM)

Rev. No. 02	Amd. No.	Reaffirmed	Prepared BHOPAL	Issued Corp. R&D	Dt. of 1st Issue 1st October 1995
Dt.: 01.11.2008	Dt:	Year:			

**5.0 MANUFACTURE:**

The film shall be comprised of several layers of plastic film placed criss-cross over one another and bonded by a special cold-roll technique. Film shall be resistant to most of organic & inorganic chemicals.

'BHEL' emblem of size A40 shall be embossed by thermostatic control on the film at an interval of 1000 mm along the length of the film.

The colour of the emblem shall be Air Craft Blue (Shade No. 108) as per IS: 5 or Black / Red.

One vertical heat sealing joint will be acceptable for films between 1200 mm and 2400 mm at the interval of 1200 mm width.

Two vertical heat sealing joint will be acceptable for films above 2400 mm at the interval of 1200 mm width.

6.0 APPEARANCE AND FINISH:

The film shall be uniform in colour, texture and finish. And also shall be free from pinholes, undispersed raw material, streaks and foreign particles and holes, tears or blisters. The edge shall be free of nicks and cuts to unaided eye.

7.0 COLOUR:

Unless otherwise specified, the film shall be supplied in Natural Colour (essentially colourless) for 45 GSM, yellow colour for 70 GSM & Blue colour for 90 GSM. Any other colour can also be ordered, if agreed mutually.

For film of other average weights, colour shall be as stated on the order.

8.0 ODOUR:

The film shall be free from any objectionable odour.

9.0 TEST METHOD:

Unless otherwise specified, the test shall be conducted in accordance with the relevant methods of IS : 2508.

10.0 TEST SAMPLES:

One Square metre (1 sq.m) of ordered thickness shall be supplied for testing purpose.

**11.0 PHYSICAL PROPERTIES:**

Substance (GSM): 45, 50, 60, 70, 90, 105, 120, 150, 200, & 250.

Tolerance: $\pm 10\%$.

12.0 MECHANICAL PROPERTIES:**12.1 Tensile Strength at Break:**

Direction N/mm^2 , min.

Direction - I 35

Direction - II 37

12.2 Elongation at Break:

Direction - I 500 percent, min.

Direction - II 400 percent, min.

12.3 Tear Resistance in/grams (ASTM – D 1922):

GSM 45 60 70 90 105 120 150 200 250

Direction I 800 1800 1800 2150 2500 3200 3500 4500 5500

Direction II 650 1500 1500 1950 2000 2000 2500 3500 4500

13.0 INSPECTION AT SUPPLIERS' WORKS:

Whenever specified, tests and inspection are to be conducted in the presence of BHEL'S representative.

BHEL'S representative shall have free access at all times while the work on the contract is being performed, to all parts of the manufacturer's works.

The manufacturer shall offer BHEL's representative all reasonable facilities without charge to satisfy the latter that the material is being furnished in accordance with this specification. The manufacturer shall prepare and provide necessary test specimens for testing to be carried out at his premises. If facilities do not exist at his works, the manufacturer shall make necessary arrangements for carrying out the prescribed tests elsewhere.

The manufacturer shall notify BHEL's representative in advance about the readiness of the material for inspection and testing.

BHEL reserves the right to test the material at BHEL's works and the final acceptance of the material shall be based on these test results.

**14.0 TEST CERTIFICATES:**

Three copies of test certificates shall be supplied unless otherwise stated on the order.

In addition, the supplier shall ensure to enclose one copy of the test certificate along with their dispatch documents to facilitate quick clearance of the material. The test certificate shall bear the following information:

AA 514 20: Multilayered Cross Laminated Polyethylene Film.

Rev. No. 02

BHEL Order No.

Batch / Lot No.

Results of dimensional inspection.

Test results of clauses 11 and 12.

15.0 PACKING AND MARKING:

To be supplied in bundles / packages suitably packed to prevent damage during transit and storage.

AA 514 20

BHEL Order No.

Manufacturer's name and grade

Batch No. / Lot No. and date of manufacture

Average weight, Width, Length and colour

Net weight of the Bundle / Package

16.0 REJECTION AND REPLACEMENT:

In the event of any film proving defective during the course of preparation, testing, subsequent use, etc such material shall be rejected notwithstanding any previous certification of satisfactory testing and / or inspection.

The supplier shall under take to replace the rejected film at his own cost and the rejected material shall be taken by the supplier after fulfilling the commercial terms and conditions.

17.0 REFERRED STANDARDS (Latest Publications Including Amendments) :

1. IS: 5 2. IS: 2508 3. ASTM - D 1992

This page intentionally left blank



CORPORATE PURCHASING SPECIFICATION

AA51401

Rev No. 03

PAGE 1 of 6

CONIFEROUS TIMBER FOR GENERAL PACKING PURPOSES

1.0 GENERAL:

This specification governs the quality requirements of Coniferous timber supplied in the form of planks, battens beams and sleepers. The coniferous timber differs from non-coniferous (broad leaf) timber in its gross appearance, anatomical structure and properties. In general, it works more easily under the tools and can be easily nailed.

2.0 APPLICATION:

Used for general packing purposes.

3.0 COMPLIANCE WITH NATIONAL STANDARDS:

There is no National standard covering this material. However, assistance has been derived from the following National standards:

IS: 190 – 1991 Grade I : Coniferous Sawn Timber (Baulks & Scantling)

IS: 6662 – 1993 : Timber Species Suitable For Wooden Packaging
Groups III & IV

4.0 TERMINOLOGY:

For the purpose of this specification, the definitions given in IS: 707 (Glossary of terms applicable to timber and timber products) shall apply except for the beam which is defined as follows:

Beam is defined as converted timber whose cross-sectional dimensions exceed 50mm in both directions.

5.0 SPECIES:

Shall be as stated on the order. Some standard species are:

<u>Trade Name</u>	<u>Botanical Name</u>	<u>Abbreviation</u>
Fir	Abies pindrow	FIR
Deodar	Cedrus deodara	DEO
Chir	Pinus roxburghil	CHR
Kali	Pinus wallichians	KAL
Khasi Pine	Pinus khasya	KPI
Spruce	Picca smithiana boiss	SPR

Revisions:

Cl. 6.2.2 of MOM of WG – (T&PM)

APPROVED:

INTERPLANT MATERIAL RATIONALISATION COMMITTEE – MRC(T&PM)

Rev No.03

Amd No.01

Reaffirmed

Prepared

Issued

Dt. of 1st Issue

Dt:01-10-1995

Dt:02-05-2002

Year:2018

HEP, Bhopal

Corp.R&D

MAR. '80

CORPORATE PURCHASING SPECIFICATION



6.0 DIMENSIONS AND TOLERANCES:

6.1 Sizes:

Width, thickness and length of timber shall be clearly stated on the order.

6.2 Tolerances:

6.2.1 Width : 50 to 250 mm Tolerance : +3 mm

6.2.2 Thickness: 20 to 250 mm Tolerance: +3 mm
- 1 mm

6.2.3 Length:

Standard length : 1 to 12 metres in multiples of 0.5 metre
Tolerance : $\pm 2\%$ or ± 25 mm whichever is less.

Note:

1.0 Measurements:

1.1 When nominal sizes are ordered, length, width and thickness shall be measured on the basis of accepted sizes. Plus tolerances shall not be added while computing the volume.

1.2 The measurements of length, width, thickness and computation of volume shall be as follows:

- a) The length shall be measured in metres in midline of a piece. The fractions of a metre shall be rounded off to the nearest lower 10 mm.
- b) The width shall be measured at the narrowest place in millimetres and shall be rounded off to the nearest lower one millimetre.
- c) The thickness shall be measured at the narrowest place in millimeters and shall be rounded off to the nearest lower one millimeter.
- d) The volume shall be computed in cubic meters correct to three places of decimal on the basis of accepted sizes

2.0 Single sampling plan based on IS: 2500 shall be followed.

7.0 MOISTURE CONTENT:

The timber shall have moisture content as stated below within a depth of 15mm from the surface excluding a length of 300mm from each end at the time of inspection. The moisture content will be determined in accordance with IS: 287

October to June : 30%

July to September (Rainy season): 40%



CORPORATE PURCHASING SPECIFICATION

AA51401

Rev No.03

PAGE 3 of 6

8.0 FREE FROM DEFECTS:

Timber shall be free from the following defects:

Brashness, splits across the grain, shakes, spring, twist, insect attack, any kind of decay (rot), any sign of Infection, open centre heart, centres heart on planks and any other defect.

Defects to the extent specified below are permissible. These defects shall be measured in accordance with IS: 3364.

8.1 Bow:

Shall be permissible up to a maximum of 2 mm for 300 mm length.

8.2 Cud:

Shall be permissible up to a maximum of 6 mm for 300 mm width

8.3 Centre heart:

Shall be permissible only on sleepers when it is not further than 35 mm from the nearest edge. This does not apply to beams of cross sections above 200 X 200 mm.

8.4 Wane:

- a) For sections up to and including 150 X 150 mm:

Shall be permissible upto $\frac{1}{5}$ of the width on the broad face subject to a maximum of 70 mm and upto $\frac{1}{3}$ of the width on the narrow face subject a maximum of 50 mm, provided that one broad face is completely free from this defect. The wane shall be measured at its deepest part

- b) For sections above 150 X 150 mm:

The cumulative lengths of waness on all the sides should not be more than one length of the piece.

8.5 End splits:

The longest end split at each end shall be measured and the lengths added together. The total length of these shall not exceed 80mm per meter run of the piece.

8.6 Live knots:

8.6.1 Knots on the surface:

- a) Up to & including 25 mm diameter:

A maximum of 5 knots/meter length are permissible. However, the knots shall not be so grouped or located as to affect the strength of the piece.

- b) Over 25mm and up to and including 70 mm diameter:

A maximum of 2 knots/metre length are permissible.

CORPORATE PURCHASING SPECIFICATION



8.6.2 Knots on the edges:

- a) Up to and including 10 mm diameter and for full thickness:

A maximum of 2 knots/metre length are permissible

- b) Over 10 mm and up to & including 50 mm diameter and for less than half thickness:

A maximum of 2 knots/metre length are permissible.

8.7 Dead knots:

- a) Below 10 mm diameter:

A maximum of 3 knots/metre length are allowed provided that the knots are not so grouped or located as to affect the strength.

- b) From 10 mm to up to and including 25mm diameter:

A maximum of 2 knots allowed to the extent of 1 knot/metre length.

- c) Above 25 mm diameter:

Not allowed

Note: (For clauses 8.6 & 8.7): Major axis of the knot should be taken as the diameter of the knot

8.8 Surface cracks:

Surface cracks with a maximum depth of 10% of the thickness are permissible. A continuous crack of any depth all along the length is not permissible.

8.9 Sap Wood:

Permissible up to a maximum of 12 percent of the cross sectional area.

9.0 END COATING:

Timber shall be coated with any of the following effective compositions upto a distance of 80 mm from each end

- 9.1 Thick coal tar or bituminous paint.

- 9.2 Resin and lamp black (10:1) melted, mixed and applied hot.

- 9.3 Hardened gloss oil.

- 9.4 Paraffin wax.

- 9.5 Molasses and lime (3:1).

- 9.6 Geru/Yellow clay



CORPORATE PURCHASING SPECIFICATION

AA51401

Rev No.03

PAGE 5 of 6

10.0 INSPECTION AT SUPPLIER'S WORKS:

Whenever specified, tests and inspection are to be conducted in the presence of BHEL's representative. BHEL representative shall have free access at all times while work on the contract is being performed to all parts of the manufacturer works. The manufacture shall offer BHEL's representative all reasonable facilities, without charge, to satisfy the latter that the material is being furnished in accordance with this specification.

The manufacturer shall prepare and provide necessary test specimens for testing to be carried out at his premises. If facilities are not available at his works the manufacturer, shall make necessary arrangements for carrying out the prescribed tests elsewhere. The manufacturer shall notify BHEL in advance about the readiness of the material for inspection and testing. BHEL reserves the right to test the material at BHEL's Works and the final acceptance of the material shall be based on these test results

11.0 TEST CERTIFICATES:

Three copies of test certificate shall be supplied unless otherwise stated on the order.

In addition, supplier shall ensure to enclose one copy of test certificate along with their dispatch documents to facilitate quick clearance of the material.

The test certificate shall have the following information:

AA51401 (Rev.No. 03): CONIFEROUS TIMBER FOR GENERAL PACKING PURPOSES

BHEL order No.:

Supplier's References:

Type & Specie:

Treatment, if any:

Results of Dimensional Inspection:

Moisture content:

Defects as per clause 8.0:

Size:

Quantity supplied:

12.0 MARKING:

The timber shall be marked/painted with the following:

AA 514 01

BHEL order No. :

Supplier's Name :

Size & Quantity :

CORPORATE PURCHASING SPECIFICATION



13.0 REJECTION AND REPLACEMENT:

If the material does not conform to the requirements of this specification or found defective during further processing, such material shall be rejected not withstanding any previous certification of satisfactory testing and/or inspection. The supplier shall under take to replace the rejected consignment at his own cost and the rejected material shall be taken back by the supplier after fulfilling the commercial terms and conditions.

14.0 REFERRED STANDARDS:

The following is the list of the latest standards, as published by the respective issuing bodies, referred to in this specification.

- | | | |
|-------------|-------------|-------------|
| 1) IS: 190 | 2) IS: 287 | 3) IS: 707 |
| 4) IS: 2500 | 5) IS: 3364 | 6) IS: 6662 |