

DISH END FOR AMMONIA TANK

Dish end for anhydrous Ammonia Tank shall be as per BHEL Drawing number: 3-SR-100-00044, with material specification SA516 Gr. 70N and as per technical delivery conditions TDC:6:406 Rev: 00)

Remarks

1. Supplier shall be from PESO certified fabrication shop.
2. Quality plan shall be submitted by vendor for approval in line with the sample quality plan enclosed.
3. Bidder shall submit compliance to Pre-qualification requirement Annexure-B along with supporting documents as mentioned in clause 7 of Annexure-B.

Annexure-B

Technical Pre-Qualification Requirement (PQR) for

Dished End of Anhydrous Ammonia Storage Tank

1. The bidder shall be PESO approved for design, manufacturing, testing of pressure vessels as per SMPV (U) rules of PESO.
2. The bidder shall have experience of design, manufacturing, testing and inspection of pressure vessels as per ASME Sec VIII Division1.
3. The vendor shall be an established **Dished End (petal type or formed type)** supplier and having adequate Engineering, Manufacturing, testing and servicing facilities and shall furnish technical backup documents in proof for above requirements.
4. The vendor shall have experience of having supplied **Dished End for storage tanks** as per the technical specification / drawing for anhydrous ammonia application or application of similar severity. Supply reference list with details of PO, PO date, customer name shall be submitted.
5. Proven track record is required. Minimum One end user certificate (to suit minimum volume of Tank is 185 m3) for their product supplied meeting requirements specified in enquiry specification or greater.

(or)

Successfully executed two POs for the tanks (to suit minimum volume of 185 m3) meeting requirements specified in enquiry specification or greater.

Vendor to submit the corresponding datasheets / drawings / technical documents of supplied item as per end user certificate/PO.

6. In case of ordering, the Vendor shall have the responsibility for the following and same to be confirmed point wise.
 - i) Vendor should have the component replacement responsibility in case of defect / failure.
 - ii) Experts from Vendor's side shall associate in commissioning activities at site, if required.
 - iii) Vendor should ensure the product performance during erection & commissioning and ensure performance guarantee.

7. Backup document checklist to meet PQR to the fullest satisfaction of BHEL:

| S. No | Document description | Check list |
|-------|--|--------------------------|
| 1 | Documents to meet clause(1&2) | <input type="checkbox"/> |
| 2 | Supply reference document (General reference list) to meet clause (3) | <input type="checkbox"/> |
| 3 | Product Catalogues to meet clause (4) | <input type="checkbox"/> |
| 4 | Min. one end user certificate (or) Two POs to meet clause (5) | <input type="checkbox"/> |
| 5 | Confirmation to clause meet clause (6) | <input type="checkbox"/> |



Product: PLATES FOR ANHYDROUS AMMONIA TANK FOR PATRATU (1828-1830), PANKI (1728), BHUSAWAL (1727) & YADADRI (1823-1827) PROJECTS

Record of revisions: Rev 00 Dt.21.11.2019: Fresh issue

1.0 MATERIALS

Specification : ASME (2017 Edition)
Carbon steel(CS) : SA 516 Gr. 70
Additional Requirements : As listed below (supplementary to Specification)
Size and Qty. : As per Purchase order(PO)

2.0 CHEMICAL COMPOSITION & PROCESS

- a) Fully killed steel
- b) Final rolling: lengthwise
- c) Plates may be made from ingots or strand cast slabs. Reduction ratio in thickness from slab/ingot to plate shall be at least 3:1.
Sufficient "Top of Ingot" to be discarded to ensure plate free of segregation. After top discard, the increase in Carbon content at the top-mid width, mid thickness of the plate shall not exceed 20% of the reported ladle analysis value. This value shall be reported in Test Certificate.
- d) Ladle analysis: minimum one sample per cast; Product analysis: minimum one sample per plate as rolled.
Maximum Carbon: 0.25%
Carbon Equivalent: As per S20 of SA20

3.0 HEAT TREATMENT (HT)

Normalize at 880-920 °C

4.0 SIMULATION HEAT TREATMENT for test coupons in addition to Cl.:3.0

CS: Normalize: 880-920 °C for 1hr/ inch of thickness, SR:610±15 °C for 3 hr/inch of thickness, furnace cool to 400°C; ROH/ROC for SR: < 220°C/hr divided by t in inches, but need not be slower than 55 °C/hr.

5.0 MECHANICAL TESTS on simulation Heat Treated coupon:

Extent of test: For each rolled/mother plate
Tensile test; Orientation of Specimen: Transverse to rolling direction
Hardness(max.): 175 BHN

6.0 NON DESTRUCTIVE TEST AFTER HT

Ultrasonic test: SA578. Acceptance: Level B.

7.0 DIMENSIONAL TEST

All dimensions shall be as per PO. Tolerance on thickness of plates shall be positive only

8.0 FINISH AND REPAIRS

Plates to be free of mill scales, edge crack & other injurious defects. Repairs by fusion welding are prohibited. Mechanical removal of defects is permitted subject to availability of min. thickness & smooth surface.

9.0 MARKING

Specification, grade, Melt number, Size, Plate number, Maker's emblem/ code and Inspecting Authority's seal to be stamped on each plate. The marking shall be by stenciling and low stress stamp and bordered by white paint. Rolling direction shall be marked by paint. PO No., "BHEL - Tiruchirappalli" & weight to be painted on the product.

10.0 INSPECTION AND CERTIFICATION

Products shall be inspected at works & test certificates (in English only) shall be countersigned by Inspecting Authority (any reputed third party).

All the products shall be accompanied by manufacturer's mill test certificate (in English only) supplied against every purchase order. Additionally, manufacturer's test certificate (in English only) shall be submitted meeting all the requirements contained in the purchase order, this TDC, and the applicable ASME specification with the following details.

- i. Purchase Order No (BHEL), TDC No & Rev No, Test certificate number & Date, Quantity.
- ii. Specification and Grade with applicable year of code, Heat Number, Plate number.





BHEL - Tiruchirappalli - 620014, India.
Quality Assurance Department
TECHNICAL DELIVERY CONDITIONS

DOC No: TDC:6:406 Rev No: 00
Effective Date: 21.11.2019
Page: 2 of 2

Product: PLATES FOR ANHYDROUS AMMONIA TANK FOR PATRATU (1828-1830), PANKI (1728), BHUSAWAL (1727) & YADADRI (1823-1827) PROJECTS

- iii. Steel making process, Chemistry including incidental elements - Ladle and Product analysis [as per CI 2(c) & 2(d)].
- iv. Heat Treatment details of material and test coupons like temperature, soaking time, cooling medium etc.
- v. The certification of reduction ratio in thickness $\geq 3:1$ from a strand-cast slab/ingot to plate shall be reported in the test certificate.
- vi. Mechanical test results including Hardness and grain size
- vii. NDE results with reference & acceptance standards.
- viii. Print of the stamp of Inspecting Officer, which is used on the plate.
- ix. The manufacturer shall furnish a certificate of compliance stating that the plates have been manufactured, inspected, and tested in accordance with the requirements of the applicable product specification.

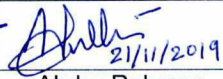
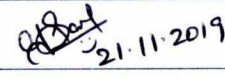
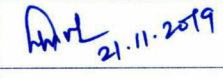
11.0 End Use: The plates are intended to manufacture Anhydrous Ammonia Tanks of Selective Catalytic Reduction systems meeting ASME Sec VIII Div. 1. These plate shall be capable of undergoing forming, bending and welding operations necessary for the application without developing defects.

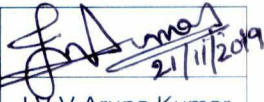
| | | | | | |
|--|---|---|--|---|---|
|  21.11.2019 |  21/11/2019 |  21.11.2019 |  21.11.2019 |  21/11/19 |  21/11/2019 |
| A Sakthi Ganesh | Abdur Rahman Sultan | G Saravana Kumar | M Nadanakumar | R. Dharmar | J V V Aruna Kumar |
| Dy Manager /QA | Sr Engineer/QA | DGM/PE-FB | AGM/MM | AGM/QC | SDGM/QA |
| Prepared By | | Reviewed By | | | Approved By |

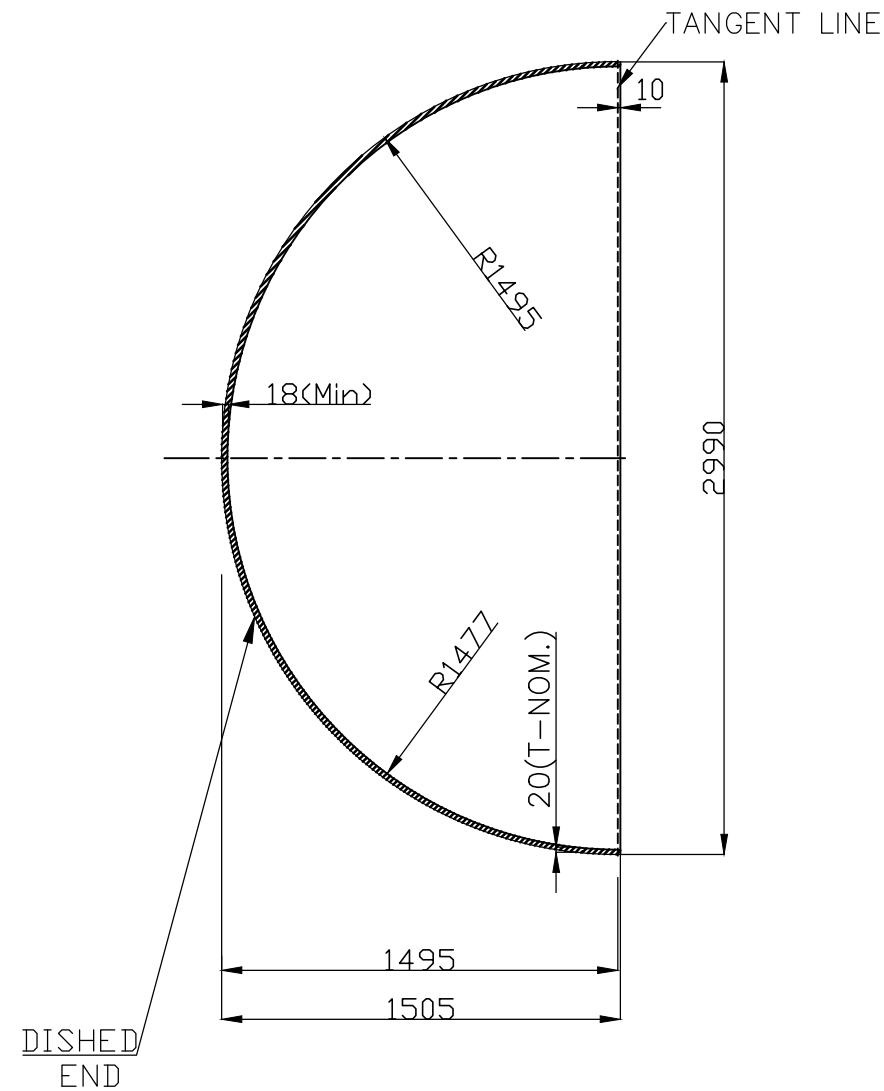

NOTES: -

- DESIGN,MANUFACTURING AND INSPECTION AS PER ASME SEC-VIII, DIVISION-1, LATEST EDITION.
- ALL DIMENSION SHOWN ARE FINISHED DIMENSIONS.
- DISHED END TO BE SUPPLIED WITHOUT EDGE PREPARATION BUT WITH ADDITIONAL STRAIGHT PORTION (10mm)AS INDICATED IN THE DRAWING.
- NORMALIZING IS TO BE DONE AFTER FORMING.
- MATERIAL SPECIFICATION :SA516 GR70N.
- DISHED CAN BE EITHER BE PETAL FORMED OR PRESS FORMED PROCESS.SUITABLE THINNING ALLOWANCE TO BE TAKEN CARE BY VENDOR TO ENSURE MIN.18mm THICKNESS.
- FOR MATERIAL PROCUREMENT VENDOR TO FOLLOW TDC ATTACHED WITH THIS ENQUIRY.
- VENDOR QUALITY PLAN SHALL BE PROVIDED FOR BHEL APPROVAL.
- VENDOR SHALL HAVE PESO CERTIFICATE FOR MANUFACTURING.
- VENDOR SHALL HAVE 'U' STAMP FOR ASME CALCULATION.
- VENDOR SHALL PROVIDE DESIGN CALCULATION AND DRAWING FOR BHEL APPROVAL BEFORE PROCEEDING WITH MANUFACTURE.

| | | | | | | | | | | |
|----------------|-------------|------------------|-----|----------------|---------|----------------|-------|------|-------------|----------------|
| VARIANT NUMBER | ITEM NUMBER | DESCRIPTION | STD | DRAWING NUMBER | ITEM NO | MATERIAL CODE | A/C/P | UNIT | UNIT WEIGHT | QTY |
| | | | | | VAR NO | MATERIAL SPECN | | | DI | |
| | 01 | DISHED END COVER | | | | SA 516 GR 70N | A | | ~2300 | AS PER ENQUIRY |

| | | |
|------|------|-------------|
| REV | DATE | ALTERED : |
| 01 | | CHD & APPD: |
| ZONE | | |

| | | | | | |
|--|--------------------------|---|------------|----------------|-----------------------|
| CAUTION: The information on this document is the property of BHARAT HEAVY ELECTRICALS LTD. It must not be used directly or indirectly in any way detrimental to the interest of the company. | | TYPE OF PRODUCT OR NAME OF CUSTOMER/PROJECT | | | |
| | | Bharat Heavy Electricals Ltd UNIT: HIGH PRESSURE BOILER PLANT TIRUCHIRAPALLI - 620014 | | | |
| DEPT | ALL DIMENSIONS ARE IN MM | PROJECTION | SCALE | WEIGHT (Kg) | REF TO ASSY / OLD DWG |
| 355-055 | | First Angle | NTS | ~2300 | |
| DRN | NAME | SIGNATURE | DATE | | |
| CHD | N. FAZIL | | 11.02.2022 | | |
| APPD | SRINIVASU. A | | 11.02.2022 | | |
| TITLE | | | | DRAWING NO : | REV |
| DISHED END FOR ANHYDROUS AMMONIA TANK | | | | 3-SR-100-00044 | 00 |

| | | | | | | | | | | | |
|--|---------------------------------|--|--|--|---|--|--|-------------------------------|--|--|--|
|  | MANUFACTURER'S NAME AND ADDRESS | SAMPLE QUALITY PLAN | | | | | | PROJECT : | | | |
| | | ITEM: Dished Ends for Anhydrous Ammonia Tanks | | | QP NO: CQP: DE:SCR Rev: 00 | | | PACKAGE : | | | |
| | | SUB-SYSTEM: SCR SYSTEM | | | DATE: 29-04-2022 | | | CONTRACT NO: BHEL CUST NO: | | | |
| Page 1 of 4 | | | | | | | | | | | |

| SL. NO | COMPONENT & OPERATIONS | CHARACTERISTICS | CLASS | TYPE OF CHECK | QUANTUM OF CHECK | REFERENCE DOCUMENT# | ACCEPTANCE NORMS | FORMAT OF RECORDS | | AGENCY | | | | REMARKS |
|--------|------------------------|-----------------|-------|---------------|------------------|---------------------|------------------|-------------------|----|--------|-----|--|--|---------|
| | | | | | | | | M | C | T | N | | | |
| 1. | 2. | 3. | 4. | 5. | 6. | 7. | 8. | 9. | D* | *** | 10. | | | 11. |

| | | | | | | | | | | | | | | |
|-------|---|------------------------------|---|--------------|------|---|------------------------------|--|--|---|---|--|--|--|
| 1.0 | Review of drawing and design calculation | correctness of documents | A | verification | 100% | ASME Sec VIII Div.1 & BHEL drawing | Drawing & design calculation | | | H | H | | | |
| 1.1 | Review of Procedures and Documents (Procedure to be submitted to BHEL and manufacturing shall start after review by BHEL) | | | | | | | | | | | | | |
| 1.1.2 | Review of PT procedure | Correctness and completeness | A | verification | 100% | ASME Sec V Article 6, ASME Sec VIII Div.1 & drawing | Proce dure | | | H | V | | | |
| 1.1.3 | Review of RT procedure | Correctness and completeness | A | verification | 100% | ASME Sec V Article 2, ASME Sec VIII Div.1 & drawing | Proce dure | | | H | V | | | |
| 1.1.4 | Review of UT procedure | Correctness and completeness | A | verification | 100% | ASME Sec V Article 4, ASME Sec VIII Div.1 & drawing | Proce dure | | | H | V | | | |
| 1.1.5 | Review of Forming Procedure | Correctness and completeness | A | verification | 100% | ASME Sec VIII Div.1 & drawing | Proce dure | | | H | V | | | |
| 1.1.6 | Review of Heat treatment procedure | Correctness and completeness | A | verification | 100% | ASME Sec VIII Div.1 & drawing | Proce dure | | | H | V | | | |

| | | | | | |
|-----------------------------|------------------------|---|-------------------------|--------------|--|
| | | LEGEND: *RECORDS IDENTIFIED WITH "TICK" (✓) SHALL BE ESSENTIALLY INCLUDED IN QA DOCUMENTATION *** M: MANUFACTURER, C: BHEL / BHEL NOMINATED INSPECTION AGENCY, T: PESO APPROVED TPIA (shall involve during manufacturing, as appropriate), N: CUSTOMER A:CRITICAL B:MAJOR C:MINOR WPS – WELDING PROCEDURE SPECIFICATION, WQR – WELDER QUALIFICATION RECORDS TC – TEST CERTIFICATES/REPORTS R: RECORDS, H: HOLD P: PERFORM, W: WITNESS, V: VERIFICATION OF DOCUMENTS/RECORDS | FOR CUSTOMER USE | DOCUMENT NO. | |
| A Sakthi Ganesh | M Jeyaram | | | | |
| PREPARED BY | REVIEWED & APPROVED BY | | | REVIEWE D BY | NAME & SIGN. OF APPROVING AUTHORITY & SEAL |
| NAME & SIGNATURE | | | | | |

| | | | | | | | | | | | |
|--|---------------------------------|--|--|--|---|--|--|-------------------------------|--|--|--|
|  | MANUFACTURER'S NAME AND ADDRESS | SAMPLE QUALITY PLAN | | | | | | PROJECT : | | | |
| | | ITEM: Dished Ends for Anhydrous Ammonia Tanks | | | QP NO: CQP: DE:SCR Rev: 00 DATE: 29-04-2022 | | | PACKAGE : | | | |
| | | SUB-SYSTEM: SCR SYSTEM | | | | | | CONTRACT NO: BHEL CUST NO: | | | |

Page 2 of 4

| SL. NO | COMPONENT & OPERATIONS | CHARACTERISTICS | CLASS | TYPE OF CHECK | QUANTUM OF CHECK | REFERENCE DOCUMENT# | ACCEPTANCE NORMS | FORMAT OF RECORDS | | AGENCY | | | | REMARKS |
|--------|------------------------|-----------------|-------|---------------|------------------|---------------------|------------------|-------------------|----|--------|-----|---|---|---------|
| | | | | | | | | M | C | T | N | M | C | |
| 1. | 2. | 3. | 4. | 5. | 6. | 7. | 8. | 9. | D* | *** | 10. | | | 11. |

| | | | | | | | | | | | | | | |
|-------|--|---|---|---|------------|--|-------------------|---|---|---|--|--|--|--|
| 2.0 | Plates for Dished Ends SA 516 Gr.70 ## | Chemical, Simulation heat treatment Mechanical tests Soundness (UT) @ | A | TC Verification | 100% | Material specification @ SA 578 to Level B | Manufacturer TC** | ✓ | P | V | | | | ** EN 10204 Ty 3.2 ## as per TDC:6:406 (latest) |
| 2.1 | Welding Consumables | Chemical, Mechanical tests, as applicable | A | TC Verification | Each batch | ASME Sec.II C | Manufacturer TC | ✓ | P | V | | | | |
| 2.2 | INPROCESS CONTROL | | | | | | | | | | | | | |
| 2.2.1 | Welding Procedure Qualification | PWHT for test coupon Tensile, Bend and Impact (as applicable) | B | Document Review Mechanical Test Impact Test | 100% | PWHT as required for equipment ASME Sec.IX, UG-84 | PQR & WPS | | P | V | | | | |
| 2.2.2 | Welders Performance Qualification | Weld Quality | B | NDE-RT | 100% | ASME Sec IX | WPQ | | P | V | | | | |
| 2.2.3 | Layout marking | Size and dimensions | B | Measurement | 100% | Drawing | - | | P | V | | | | |
| 2.2.4 | Cut edges of plates | Surface check | B | NDE-MPI/LPI | 100% | Mandatory Appendix 6 or 8 of ASME Sec VIII Div.1 | R | | P | V | | | | |

| | | | | | | | | | | | | |
|-----------------------------|--|--|--|--|--|--|-------------------------|--|--|--|--|--|
| | | LEGEND: *RECORDS IDENTIFIED WITH "TICK" (✓) SHALL BE ESSENTIALLY INCLUDED IN QA DOCUMENTATION *** M: MANUFACTURER, C: BHEL / BHEL NOMINATED INSPECTION AGENCY, T: PESO APPROVED TPIA (shall involve during manufacturing, as appropriate), N: CUSTOMER A:CRITICAL B:MAJOR C:MINOR WPS – WELDING PROCEDURE SPECIFICATION, WQR – WELDER QUALIFICATION RECORDS TC – TEST CERTIFICATES/REPORTS R: RECORDS, H: HOLD P: PERFORM, W: WITNESS, V: VERIFICATION OF DOCUMENTS/RECORDS | | | | | FOR CUSTOMER USE | | DOCUMENT NO. | | | |
| A Sakthi Ganesh | | M Jeyaram | | | | | | | | | | |
| PREPARED BY | | REVIEWED & APPROVED BY | | | | | | | | | | |
| NAME & SIGNATURE | | | | | | | REVIEWED BY | | NAME & SIGN. OF APPROVING AUTHORITY & SEAL | | | |

| | | | | | | | | | | | |
|--|---------------------------------|--|------------------|--|---------------------------|---------------|--|--------------|--|--|--|
|  | MANUFACTURER'S NAME AND ADDRESS | SAMPLE QUALITY PLAN | | | | | | PROJECT : | | | |
| | | ITEM: Dished Ends for Anhydrous Ammonia Tanks | | | QP NO: CQP: DE:SCR | | | PACKAGE : | | | |
| | | SUB-SYSTEM: SCR SYSTEM | | | Rev: 00 | | | CONTRACT NO: | | | |
| | | | DATE: 29-04-2022 | | | BHEL CUST NO: | | | | | |
| Page 3 of 4 | | | | | | | | | | | |

| SL. NO | COMPONENT & OPERATIONS | CHARACTERISTICS | CLASS | TYPE OF CHECK | QUANTUM OF CHECK | REFERENCE DOCUMENT# | ACCEPTANCE NORMS | FORMAT OF RECORDS | | AGENCY | | | | REMARKS |
|--------|------------------------|-----------------|-------|---------------|------------------|---------------------|------------------|-------------------|----|--------|-----|---|---|---------|
| | | | | | | | | M | C | T | N | M | C | |
| 1. | 2. | 3. | 4. | 5. | 6. | 7. | 8. | 9. | D* | *** | 10. | | | 11. |

| | | | | | | | | | | | | | | |
|-------|---|---|---|-----------------------------|------|--|---|---|---|---|--|--|--|--|
| 2.3 | FORMING | | | | | | | | | | | | | |
| 2.3.1 | HT after cold forming - Dished end | Time, Temperature control | A | Review of chart | 100% | Stress Relieve (SR) if F.E >5% SR : SA 516 Gr. 70-610±15 °C | R | ✓ | P | V | | | | F.E: Fibre Elongation Single radius=50t/R |
| 2.3.2 | HT after hot forming of Dished end (when hot forming is applicable) @ | Time, Temperature control | A | Review of chart | 100% | Normalizing## | R | ✓ | P | V | | | | @ if hot forming temperature exceeds Normalizing range Hot forming shall not be below 621 °C ## as per Mill TC |
| 2.3.3 | Dished End – petal joint & petal to crown (if applicable) | Fitup – Alignment, root gap, dimension, profile | B | Visual & measurement | 100% | Inspection Report | R | ✓ | P | V | | | | |
| | | completed weld - Weld reinforcement, size and surface quality | B | Visual, Measurement MPI/LPI | 100% | Drawing, Mandatory Appendix 6 or 8 of ASME Sec VIII Div.1 | R | ✓ | P | V | | | | MPI/LPI on the inside and outside surface |
| | | Weld quality | B | NDE – MPI/LPI @# | 100% | Mandatory Appendix 6 or 8 of ASME Sec VIII Div.1 | R | ✓ | P | W | | | | @# after back grinding, if done |
| | | Weld quality | B | NDE-RT | 100% | UW 51 of ASME & Appendix 4 of Sec.VIII-Div.1 | R | ✓ | P | W | | | | |

| | | | | | | |
|-----------------------------|------------------------|---|-------------------------|--|--------------|--|
| | | LEGEND: *RECORDS IDENTIFIED WITH “TICK” (✓) SHALL BE ESSENTIALLY INCLUDED IN QA DOCUMENTATION *** M: MANUFACTURER, C: BHEL / BHEL NOMINATED INSPECTION AGENCY, T: PESO APPROVED TPIA (shall involve during manufacturing, as appropriate), N: CUSTOMER A:CRITICAL B:MAJOR C:MINOR WPS – WELDING PROCEDURE SPECIFICATION, WQR – WELDER QUALIFICATION RECORDS TC – TEST CERTIFICATES/REPORTS R: RECORDS, H: HOLD P: PERFORM, W: WITNESS, V: VERIFICATION OF DOCUMENTS/RECORDS | FOR CUSTOMER USE | | DOCUMENT NO. | |
| A Sakthi Ganesh | M Jeyaram | | | | | |
| PREPARED BY | REVIEWED & APPROVED BY | | | | | |
| NAME & SIGNATURE | | | REVIEWED BY | NAME & SIGN. OF APPROVING AUTHORITY & SEAL | | |

| | | | | | | | | | | | |
|--|---------------------------------|--|--|--|---|--|--|-------------------------------|--|--|--|
|  | MANUFACTURER'S NAME AND ADDRESS | SAMPLE QUALITY PLAN | | | | | | PROJECT : | | | |
| | | ITEM: Dished Ends for Anhydrous Ammonia Tanks | | | QP NO: CQP: DE:SCR Rev: 00 | | | PACKAGE : | | | |
| | | SUB-SYSTEM: SCR SYSTEM | | | DATE: 29-04-2022 | | | CONTRACT NO: BHEL CUST NO: | | | |
| Page 4 of 4 | | | | | | | | | | | |

| SL. NO | COMPONENT & OPERATIONS | CHARACTERISTICS | CLASS | TYPE OF CHECK | QUANTUM OF CHECK | REFERENCE DOCUMENT# | ACCEPTANCE NORMS | FORMAT OF RECORDS | | AGENCY | | | | REMARKS |
|--------|------------------------|-----------------|-------|---------------|------------------|---------------------|------------------|-------------------|----|--------|-----|--|--|---------|
| | | | | | | | | M | C | T | N | | | |
| 1. | 2. | 3. | 4. | 5. | 6. | 7. | 8. | 9. | D* | *** | 10. | | | 11. |

| | | | | | | | | | | | | | | |
|-------|---------------------------------|---|---|--------------|------|---|--|----------|---|---|---|--|--|----------------------------|
| 2.3.4 | Dimension Inspection Dished end | Profile, Diameter, Height, Thickness & Ovality | B | Measurement | 100% | Drawing | | R | ✓ | P | W | | | |
| 2.4 | PWHT | Time & temperature | B | Verification | 100% | WPS, ASME Sec VIII Div.1 | | HT Chart | ✓ | P | V | | | |
| 3.0 | Verification of completion | Visual, Overall Dimensions, Orientation, Review of Test Reports | B | Verification | 100% | Drawings & In-process records | | R | | P | W | | | |
| 3.1 | Identification | Stamping details | A | Visual | 100% | Drawing | | R | ✓ | P | W | | | |
| 3.2 | Surface preparation and coating | Surface condition, appearance | C | Visual | 100% | Rust preventive coat@ | | R | ✓ | P | W | | | @ after shot blasting |
| 3.3 | Certification | Documentation | A | Compilation | 100% | Contents noted under column D | | R | | P | V | | | Data Folder to be prepared |
| 3.4 | Packing and Despatch | Protection and Stability | C | Visual | 100% | Packing procedure, Despatch detail markings | | - | | P | W | | | |

| | | | | | |
|-----------------------------|------------------------|---|-------------------------|--|--|
| | | LEGEND: *RECORDS IDENTIFIED WITH "TICK" (✓) SHALL BE ESSENTIALLY INCLUDED IN QA DOCUMENTATION *** M: MANUFACTURER, C: BHEL / BHEL NOMINATED INSPECTION AGENCY, T: PESO APPROVED TPIA (shall involve during manufacturing, as appropriate), N: CUSTOMER A:CRITICAL B:MAJOR C:MINOR WPS – WELDING PROCEDURE SPECIFICATION, WQR – WELDER QUALIFICATION RECORDS TC – TEST CERTIFICATES/REPORTS R: RECORDS, H: HOLD P: PERFORM, W: WITNESS, V: VERIFICATION OF DOCUMENTS/RECORDS | FOR CUSTOMER USE | DOCUMENT NO. | |
| A Sakthi Ganesh | M Jeyaram | | | | |
| PREPARED BY | REVIEWED & APPROVED BY | | | | |
| NAME & SIGNATURE | | | REVIEWED BY | NAME & SIGN. OF APPROVING AUTHORITY & SEAL | |

Annexure – A- Additional Terms and Conditions for GeM Enquiry

The terms and condition mentioned in this document are applicable in addition to the GeM General Terms and Conditions. Bidders shall furnish pointwise confirmation/details.

| | | |
|--------------------------------------|--|--|
| Description of the Equipment: | | Dish End for Anhydrous Ammonia Tank |
| BHEL Tender No. & Date | | BID NO: GEM/2022/B/2149751 |
| <i>To be filled by bidder</i> | | |
| Name of the firm (Bidder) | | : |
| Offer reference and date | | : |
| Address | | : |
| Contact details | | <u>Contact person 1</u> Name: Designation: Office Phone: Mobile: e-mail: <u>Contact person 2</u> Name: Designation: Office Phone: Mobile: e-mail: |
| Sl. No | Terms and conditions | Vendor's confirmation |
| 1 (a) | Technical: Supply shall be as per BHEL Drawing number: 3-SR-100-00044, with material specification SA516 Gr. 70N and as per technical delivery conditions TDC:6:406 Rev: 00. Any clarifications/deviations to the specification requirements are to be clearly indicated. Hidden deviations indicated elsewhere in the offer will not be evaluated. Quality Plan meeting the minimum requirements mentioned in the sample quality plan (CQP: DE:SCR, Rev: 00) shall be submitted by bidder for approval by BHEL in case of ordering. Supply shall be as per the quality plan approved by BHEL/End customer. | |
| 1 (b) | Pre-qualification requirement: Offer shall be considered only if bidder is meeting Tender Prequalification requirement (Annexure-B). Vendor to comply with Pre-Qualification requirement of the tender and submit along with their technical bid - the credentials and other documents as indicated in the PQR in the format prescribed. Otherwise their offer will get rejected. | |
| 1 (c) | Bidder's offer will be considered for price bid opening subject to fulfilment of techno commercial suitability. | |
| 1 (d) | Inspection by BHEL/ BHEL approved TPIA/End customer. | |
| 2 | Firm Price: The quoted / finalised rates shall be Firm till execution of the supplies. Offer with PVC clause will not be considered. | |

| | | |
|-------|--|--|
| 3 (a) | <p>Delivery term: The quote shall be on FOR BHEL Trichy Stores, Tamil Nadu destination basis as indicated below inclusive of Packing, forwarding, Freight also to yours account.</p> <p>Transit Insurance is under BHEL scope.</p> | |
| 3 (b) | <p>Payment terms: Non MSE Vendor: Payment within 90 days from CRAC and on-line submission of bills and against 10% PBG of Supply value. MSE Vendor: For Micro and Small Enterprises Payment will be within 45 days from CRAC against 10% PBG of Supply value. Medium Category vendor: For Medium Enterprises Payment will be within 60 days from CRAC against 10% PBG of Supply value.</p> | |
| 4 | <p>Performance Bank Guarantee: BHEL require a performance Bank Guarantee to a value of 10% of supply valve covering the Guarantee/Warranty period. The PBG shall be in BHEL format (Format attached) which is to be opened in any one of the banks mentioned under List of Consortium Banks attachment. All banks charges shall be to vendor account only. Any deviation on PBG leads to rejection of offer.</p> | |
| 5 (a) | <p>Guarantee / Warranty Period: 18 months from the date of supply or 12 months from the date of actual put in use, whichever is earlier.</p> | |
| 5 (b) | <p>Repair & replacements: Within the guarantee period vendor has to replace / rectify the defective/ damaged items on free of cost within a reasonable time of reporting from our end.</p> | |
| 5 (c) | <p>No Deviation is permitted. If still vendor offered any deviation on the Guarantee / warranty period, it may lead to rejection of offer.</p> | |
| 6 (a) | <p>Kindly Indicate the HSN Code for all items</p> | |
| 6 (b) | <p>Rate quoted in GeM portal should be on FOR destination basis inclusive of all taxes, P&F, freight etc. Transit Insurance is under BHEL scope.</p> <p>Please indicate the applicable GST %, P & F and freight cost (in % of material cost), which is included in your quoted rate in GeM portal.</p> | |
| 7 (a) | <p>Delivery Period: Delivery period shall be as given below.</p> <ul style="list-style-type: none"> • 75 days from the date of document approval for 4 numbers. • 120 days from the date of document approval for 10 numbers. <p>Material shall be dispatched after obtaining dispatch clearance from BHEL. Delivery period mentioned anywhere else in the bid document is for indicative purpose. Delivery schedule shall be as per this clause.</p> | |
| 7 (b) | <p>Document Submission: In case of PO placements, required documents have to be submitted for approval within 15 days from the date of PO & reply for any further clarification has to be within 7 days. Any delay beyond the above specified period will be considered during LD calculation.</p> | |
| 8 | <p>Invoice date/Bill of Lading date/Airway Bill date/e-way bill/Lorry way bill date/Railway Receipt date, whichever is later will be considered for LD calculation.</p> | |

| | | |
|----|---|--|
| 9 | <p>Documents are to be submitted along with technical bid (Part-1)</p> <ol style="list-style-type: none"> 01. Covering letter 02. Unpriced offer. 03. Filled technical specification and BHEL datasheets. 04. Filled BHEL Terms and condition sheet (Annexure-A) 05. Filled Annexure-B - PQR along with supporting documents. 06. Filled in no-deviation format 07. Self-Certification as per Make in India clause 08. MSE Certificates (if applicable) <p>Note: All the pages of documents are to be signed and sealed by authorized signatory of the company. Any query during enquiry stage shall be replied within three days failing which offer may be rejected as non-responsive.</p> | |
| 10 | <p>Inspection and testing requirements:</p> <p>Inspection and testing requirements are to be carried out as per the specification and BHEL/Customer approved Drawing (All documents shall be submitted within 15 days from the date of PO for our approval), Technical spec &QP and all test certificates are to be submitted in complete set.</p> <p>Inspection notice period: For TPI inspector visit to vendor works, a minimum of 3 working days' notice period.</p> | |
| 11 | <p>Vendors shall strictly adhere to the following.</p> <ol style="list-style-type: none"> a. After material readiness and inspection completion (by TPI/ BHEL/ End Customer), vendor shall seek dispatch clearance from BHEL. b. After obtaining dispatch clearance from BHEL, vendor shall proceed to generate dispatch documents. After generating dispatch documents (Invoice, LR, E-waybill etc.) vendor shall immediately share these documents to BHEL (scan copy over email) for accounting the materials and securing insurance coverage. c. After accounting, BHEL would be issuing movement clearance to vendor immediately. Only after movement clearance is received from BHEL, actual/physical movement of goods out of vendor's premises shall commence. d. Non-adherence to the above may lead to GST authorities seizing the vehicle & goods and imposing penalty & interest. Any such implication would be to vendors account only. e. Provision of GST Act highlighted below in connection to this - Pursuant to Sec 31 of CGST Act 2017, a tax invoice has to be raised by the registered person supplying taxable goods before or at the time of removal of goods for supply to the recipient, where the supply involves movement of goods. Where a taxable person supplies any goods without issue of any invoice, the tax authorities has powers to detain the consignment and impose penalties equivalent to 200% of the tax payable as per Section 129 of CGST Act 2017. | |
| 12 | <p>Response to Tenders for Indigenous supplier will be entertained only if the vendor has a valid GST registration Number (GSTIN) which should be clearly mentioned in the offer. If the dealer is exempted from GST registration, a declaration with due supporting documents need to be furnished for considering the offer. Dealers under composition scheme should declare that he is a composition dealer supported by the screen shot taken from GSTN portal. The dealer has to submit necessary documents if there is any change in status under GST.</p> | |

| | | |
|----|--|--|
| 13 | Supplier shall mention their GSTIN in all their invoices (incl. credit Notes, Debit Notes) and invoices shall be in the format as specified/prescribed under GST laws. Invoices shall necessarily contain Invoice number (in case of multiple numbering system is being followed for billing like SAP invoice no, commercial invoice no etc., then the Invoice No. which is linked/uploaded in GSTN network shall be clearly indicated), Billed to party (with GSTIN) & Shipped to party details, item description as per PO, Quantity, Rate, Value, applicable taxes with nomenclature (like IGST, SGST, CGST & UTGST) separately, HSN/ SAC Code, Place of Supply etc. Wherever E-Invoice is applicable, the tax invoice/ CN / DN submitted by the vendor must contain the QR code generated in E-Invoice Portal & IRN. | |
| 14 | All invoices shall bear the HSN Code for each item separately (Harmonized System of Nomenclature)/ SAC code (Services Accounting Code) | |
| 15 | Invoices will be processed only upon completion of statutory requirement and further subject to following: i. Vendor declaring such invoice in their GSTR-1 Return/ IFF ii. Receipt of Goods or Services and Tax invoice by BHEL | |
| 16 | As the continuous uploading of tax invoices in GSTN portal (in GSTR-1/ IFF) is available for all (i.e. both Small & Large) tax payers, all invoices raised on BHEL may be uploaded immediately in GST portal on dispatch of material /rendering of services. The supplier shall ensure availability of Invoice in GSTN portal before submission of invoice to BHEL. Invoices will be admitted by BHEL only if the invoices are available in GSTN portal (in BHEL's GSTR-2A/ GSTR-2B). | |
| 17 | In case of discrepancy in the data uploaded by the supplier in the GSTN portal or in case of any shortages or rejection in the supply, then BHEL will not be able to avail the tax credit and will notify the supplier of the same. Supplier has to rectify the data discrepancy in the GSTN portal or issue credit note or debit note (details also to be uploaded in GSTN portal) for the shortages or rejections in the supplies or additional claims, within the calendar month informed by BHEL. | |
| 18 | In case GST credit is denied to BHEL due to non-receipt or delayed receipt of goods and/ or tax invoice or expiry of timeline prescribed in GST law for availing such ITC, or any other reasons not attributable to BHEL, GST amount claimed in the invoice shall be disallowed to the vendor. | |
| 19 | Where any GST liability arising on BHEL under Reverse Charge (RCM), the vendor has to submit the invoices to BHEL well within the timeline prescribed in GST Law, to enable BHEL to discharge the GST liability. If there is a delay in submission of invoice by the vendor resulting in delayed payment of GST by BHEL along with Interest, then such Interest payable or paid shall be recovered from the vendor. | |
| 20 | Under GST regime, BHEL has to discharge GST liability on LD recovered from suppliers/contracts. Hence applicable GST shall also be recoverable from suppliers/contractors on LD amount. For this Tax Invoice will be issued by BHEL indicating the respective supply invoice number. | |
| 21 | GST TDS will be deducted as per Section 51 of CGST Act 2017 and in line with Notification 50/2018 – Central Tax dated 13.09.2018. GST TDS certificate will be generated in GSTN portal subsequent to vendor accepting the TDS deduction in the GSTN portal & the vendor can directly download the Certificate from the GSTN Portal. | |

| | | |
|----|---|--|
| 22 | <p>MSE VENDOR: <i>Udyam Registration certificate shall be submitted by MSE vendors for availing the benefits.</i> <i>Purchase preference will be provided only if bidder applies for the same in GeM portal.</i></p> | |
| 23 | <p><u>Make in India:</u> The local supplier at the time of tender, bidding or solicitation shall be required to provide self-certification that the item offered meets the minimum local content and shall give details of the location(s) at which the local value addition is made. Counter offering for Make in India will be on package basis (non-splittable) <i>Purchase preference will be provided only if bidder applies for the same in GeM portal.</i></p> | |
| 24 | <p><u>Fraud Prevention Policy</u> Bidder along with its associate /collaborators /sub-contractors /sub-vendors / consultants / service providers shall strictly adhere to BHEL Fraud Prevention Policy displayed on BHEL website http://www.bhel.com and shall immediately bring to the notice of BHEL Management about any fraud or suspected fraud as soon as it comes to their notice.</p> | |
| 25 | <p><u>Risk purchase clause:</u></p> <p>a. In the event of any successful Tenderer's failure to fulfil any of the tender / Contract obligations including supply of whole or any part of the ordered items as per Contract / Agreement, BHEL has the right to terminate the contract and purchase from elsewhere, at the risk and cost of the defaulted supplier, either the whole of the goods or any part which the supplier has failed to deliver or dispatch within the time stipulated in the contract or if the same were not available, the best and nearest available substitute thereof. The supplier shall be liable for the additional expenditure/difference in Cost, if any, including consequential losses which BHEL may sustain by reason of risk purchase in addition to the applicable LD as per the Purchase order/contract.</p> <p>b) The decision of BHEL with regard to the additional expenditure / difference in cost and consequential losses incurred by BHEL shall be final and binding on the supplier.</p> <p>c) The amount recoverable under risk purchase shall be recovered from the defaulted supplier in all or any of the following manners:</p> <ol style="list-style-type: none"> i. from dues available in the form of Bills payable to defaulted supplier, SD, BGs against the same contract. ii. from the dues payable to defaulted supplier against other contracts in the same Region/Unit /any other region/unit iii. In-case recoveries are not possible with any of the above available options, Legal action shall be initiated for recovery against defaulted supplier. | |
| 26 | <p><u>Packing Requirements:</u></p> <ul style="list-style-type: none"> • Items shall be packed in suitable enclosure (to prevent damage/rusting due to Seashore atmospheric conditions) from all sides and also it should be covered with polythene to make it water proof. • Packing and struts shall be used to arrest rolling of items and to avoid transit damage. • Suitable arrangement (lugs/hooks) for loading and unloading of the equipment in packed condition at site. | |
| 27 | <p>The offers of the bidders who are under suspension and also the offers of the bidders, who engage the services of the banned firms /principal/agents, shall be rejected. The list of banned firms is available on BHEL web site www.bhel.com.</p> | |

| | |
|-------------|--|
| Note | <ol style="list-style-type: none">1. In the event of our customer order covering this tender being cancelled /placed on hold / otherwise modified, BHEL would be constrained to accordingly cancel / hold / modify the tender at any stage of execution.2. BHEL may negotiate the L1 rate, if not meeting our budget / estimated cost. BHEL may re-float the tender opened, if L1 price is not acceptable to BHEL.3. BHEL reserves its right to reject an offer due to unsatisfactory past performance by the respective Vendor in the execution of any contract to any BHEL project / Unit.4. Any other Techno –Commercial Terms indicated by the vendor in their offer elsewhere will be ignored. BHEL will proceed with tender evaluation as per Annexure A only. |
|-------------|--|

PART-I (No Deviation Certificate)

Note: The following Declaration to be submitted on the bidder's Letter Head, duly signed & stamped and to be attached along with your Technical bid of the tender.

===== SUPPLY OF DISH END FOR ANHYDROUS AMMONIA TANK=====

Enquiry No.: **GEM/2022/B/2149751 dated 04.05.2022**

I/We M/s.
have read and clearly understood all the Terms and conditions in Tender Schedule of and accordingly accept the same without any deviation what so ever.

- I/ We unconditionally agree to all the tender conditions and no new conditions are imposed by us in the technical / price bid. I understand in the event of imposing any condition in the technical / price bid, such condition would be ignored by BHEL and only the prices will be considered for the purpose of evaluation". In case of any deviation (Technical or commercial) the same is mentioned below.

| | | |
|----------------|---|------------------------|
| SPECIFICATION | a) TDC:6:406 Rev 00; Technical delivery conditions for Plates for Anhydrous Ammonia Tank b) 3-SR-100-00044; Drawing for Dish end for Anhydrous Ammonia Tank. c) CQP:DE:SCR Rev 00 Sample Quality Plan | |
| DOC. REFERENCE | BHEL ENQ. CALLED FOR | FIRM'S ALTERNATE OFFER |
| -Nil- | -Nil- | -Nil- |

- I/ We confirm that none of our group concern or affiliates etc., appears on the list of banned firms / companies by BHEL (list available on www.bhel.com) nor any of the Director / Partner / proprietor of bidder / such group concern or affiliate etc. are involved with such company.
- I/ We also declare that, we have not been suspended or black listed or issued with Show Cause Notice by BHEL- Trichy or any other BHEL Unit or any PSU/ Government organization.
- I/ We confirm that other than us, none of our group concerns or affiliates etc. are participating in the tender either directly or indirectly through any other agency under same proprietor / common director(s) / common partner(s).
- I/ We confirm that if any of the above statement / information furnished by us in this tender is found to be false/ fake at any stage of tender evaluation or during execution of contract, BHEL will have the right to initiate appropriate action including legal proceeds / termination of contract, recovery of damages, penalties etc. as deemed fit.

(Contractor Signature with Seal)

Contractor Signature

Contractor Seal

/ On Bidder's office letter pad /

Self-Declaration

| | |
|---------------------|----------------------------------|
| Enquiry No. | <u>GEM/2022/B/2149751</u> |
| Enquiry Date | <u>04.05.2022</u> |

In line with Government public procurement order Number P-45021/2/2017-B.E-II dated 15.06.2017, and further modified order dt. 28.05.2018 and 04.06.2020,

I / We hereby declare that I / We are a “Local Supplier” meeting the requirement of minimum local content (**.....%**) defined in the above government notification for the goods against above mentioned enquiry Number.

Details of location at which local value addition will be made is as follows:

| | |
|--------------------|--|
| Door No. | |
| Street / Address 1 | |
| Street / Address 2 | |
| District | |
| State | |
| Country | |
| PIN Code | |

We also understand that the false declarations will be considered as breach of Integrity and liable for action.

For Company Name:

Seal:

Signature:

Date:

Place:

(Please fill all the yellow color field)

BANK GUARANTEE FOR PERFORMANCE SECURITY

(Non-Judicial Stamp paper/e-stamp paper of appropriate value as per Stamp Act prevailing in the State(s))

Bank Guarantee No:

Date:

To

NAME

& ADDRESSES OF THE BENEFICIARY

IFSC AND MICR CODE

Dear Sirs,

1. In consideration of Bharat Heavy Electricals Limited (hereinafter referred to as the 'Employer' which expression shall unless repugnant to the context or meaning thereof, include its successors and permitted assigns) incorporated under the Companies Act, 1956 and having its registered office at _____¹ through its Unit at.....(name of the Unit) having awarded to (Name of the Vendor / Contractor / Supplier) (VENDOR CODE) with its registered office at _____² hereinafter referred to as the 'Vendor / Contractor / Supplier ', which expression shall unless repugnant to the context or meaning thereof, include its successors and permitted assigns), a contract Ref No.....dated³ valued at Rs.....⁴ (Rupees -----)/FC.....(in words.....) for⁵ (hereinafter called the 'Contract') and the Vendor / Contractor / Supplier having agreed to provide a Contract Performance Bank Guarantee, equivalent to% (... Percent) of the said value of the Contract to the Employer for the faithful performance of the Contract,

2. we,, (hereinafter referred to as the Bank), having registered/Head office at and inter alia a branch at being the Guarantor under this Guarantee, hereby, irrevocably and unconditionally undertake to forthwith and immediately pay to the Employer any sum or sums upto a maximum amount of Rs -----⁶ (Rupees -----) without any demur, immediately on first demand from the Employer and without any reservation, protest, and recourse and without the Employer needing to prove or demonstrate reasons for its such demand.

3. Any such demand made on the Bank shall be conclusive as regards the amount due and payable by the Bank under this guarantee. However, our liability under this guarantee shall be restricted to an amount not exceeding Rs. _____.

4. We undertake to pay to the Employer any money so demanded notwithstanding any dispute or disputes raised by the Vendor / Contractor / Supplier in any suit or proceeding pending before any Court or Tribunal, Arbitrator or any other authority, our liability under this present being absolute and unequivocal.

5. The payment so made by us under this Guarantee shall be a valid discharge of our liability for payment thereunder and the Vendor / Contractor / Supplier shall have no claim against us for making such payment.

6. We thebank further agree that the guarantee herein contained shall remain in full force and effect during the period that would be taken for the performance of the said Contract/satisfactory completion of the performance guarantee period as per the terms of the Contract and that it shall continue to be enforceable till all the dues of the Employer under or by virtue of the said Contract have been fully paid and its claims satisfied or discharged.

7. We.....BANK further agree with the Employer that the Employer shall have the fullest liberty without our consent and without affecting in any manner our obligations hereunder to vary any of the terms and conditions of the said Contract or to extend time of performance by the said Vendor / Contractor / Supplier from time to time or to postpone for any time or from time to time any of the powers exercisable by the Employer against the said Vendor / Contractor / Supplier and to forbear or enforce any of the terms and conditions relating to the said Contract and we shall not be relieved from our liability by reason of any such variation, or extension being granted to the said Vendor / Contractor / Supplier or for any forbearance, act or omission on the part of the Employer or any indulgence by the Employer to the said Vendor / Contractor / Supplier or by any such matter or thing whatsoever which under the law relating to sureties would but for this provision have effect of so relieving us.

8. The Bank also agrees that the Employer at its option shall be entitled to enforce this Guarantee against the Bank as a principal debtor, in the first instance without proceeding against the Vendor / Contractor / Supplier and notwithstanding any security or other guarantee that the Employer may have in relation to the Vendor / Contractor / Supplier's liabilities.

9. This Guarantee shall remain in force upto and including.....⁷ and shall be extended from time to time for such period as may be desired by Employer.

10. This Guarantee shall not be determined or affected by liquidation or winding up, dissolution or change of constitution or insolvency of the Vendor / Contractor / Supplier but shall in all respects and for all purposes be binding and operative until payment of all money payable to the Employer in terms thereof.

11. Unless a demand or claim under this guarantee is made on us in writing on or before the⁸we shall be discharged from all liabilities under this guarantee thereafter.

12. Any claim or dispute arising under the terms of this document shall only be enforced or settled in the Courts at Tiruchirappalli.

13. We..... BANK lastly undertake not to revoke this guarantee during its currency except with the previous consent of the Employer in writing.

Notwithstanding anything to the contrary contained hereinabove:

- a) The liability of the Bank under this Guarantee shall not exceed.....⁶

- b) This Guarantee shall be valid up to⁷
- c) Unless the Bank is served a written claim or demand on or before (minimum 3 to 6 months from the expiry date ⁸ all rights under this guarantee shall be forfeited and the Bank shall be relieved and discharged from all liabilities under this guarantee irrespective of whether or not the original bank guarantee is returned to the Bank.

14. We, _____ Bank, have power to issue this Guarantee under law and the undersigned as a duly authorized person has full powers to sign this Guarantee on behalf of the Bank.

For and on behalf of
(Name of the Bank)

Dated.....

Place of Issue.....

BANK EMAIL ID:

BANK PHONE NO:

AUTHORISED SIGNATORIES CELL PHONE NO:

BANK FAX NO:

¹ NAME AND ADDRESS OF EMPLOYER I.e Bharat Heavy Electricals Limited

² NAME AND ADDRESS OF THE VENDOR /CONTRACTOR / SUPPLIER.

³ DETAILS ABOUT THE NOTICE OF AWARD/CONTRACT REFERENCE

⁴ CONTRACT VALUE

⁵ PROJECT/SUPPLY DETAILS

⁶ BG AMOUNT IN FIGURES AND WORDS

⁷ VALIDITY DATE

⁸ DATE OF EXPIRY OF CLAIM PERIOD

| List of Consortium Banks | |
|---------------------------------|---|
| Sl. No. | Name of the bank |
| 1. | State Bank of India |
| 2. | Canara Bank |
| 3. | Axis Bank |
| 4. | Bank of Baroda |
| 5. | Central bank |
| 6. | Citi Bank N.A. |
| 7. | Deutsche Bank |
| 8. | Exim Bank |
| 9. | Federal Bank Limited |
| 10. | HDFC Bank Limited |
| 11. | Hongkong and Shanghai Banking Corporation Limited |
| 12. | Indian Bank |
| 13. | ICICI Bank Limited |
| 14. | IDBI Bank Limited |
| 15. | IndusInd Bank Limited |
| 16. | Indian Overseas Bank |
| 17. | Kotak Mahindra Bank Limited |
| 18. | Punjab National Bank |
| 19. | RBL Bank Ltd. |
| 20. | Standard Chartered Bank |
| 21. | Union Bank of India |
| 22. | Yes Bank Limited |