



**Bharat Heavy Electricals Limited**  
**(A Govt. of India Undertaking)**  
Piping Centre, 80, G. N. Chetty Road, CHENNAI – 600 017

REF: GEM/2021/B/1570474

DT: 04.10.2021

**Sub: Request For Quotation (RFQ) for supply of Horizontal clamp assembly and Riser Clamp Assembly - Reg.**

**Ref: Bid Number GEM/2021/B/1570474 dt 03.10.2021**

BHEL/Piping Centre invites RFQ's for supply of Horizontal clamp assembly and Riser Clamp Assembly. The offers should be submitted in the Government e-procurement portal (<https://gem.gov.in/>). The offer will be opened at **19.30 hrs** on the **due date 13.10.2021**.

Please find the bid document and the general terms and conditions for the GeM enquiry. Relevant drawings and technical requirements are available along with specification.

This is only a request for quotation and not an order.

Interested bidders may take a note of the same and provide your quotation in GeM.

Ms. Poongodi.V  
Deputy Manager / Purchase  
BHEL, Piping Centre  
80, G.N.Road, T.Nagar, Chennai –600 017  
Phone – 044-28161965  
Email: [poongodi@bhel.in](mailto:poongodi@bhel.in)

For any clarifications on the Enquiry you may also contact

Mr. Venkataraman E, DGM / Purchase, Phone – 044-28161325, Email: [vram@bhel.in](mailto:vram@bhel.in)

Ms. Priya Balaji, SDGM / Purchase, Phone – 044-28161244, Email: [pb@bhel.in](mailto:pb@bhel.in)

### Bid Document

<b>Bid Details</b>	
<b>Bid End Date/Time</b>	13-10-2021 19:00:00
<b>Bid Opening Date/Time</b>	13-10-2021 19:30:00
<b>Bid Life Cycle (From Publish Date)</b>	90 (Days)
<b>Bid Offer Validity (From End Date)</b>	80 (Days)
<b>Ministry/State Name</b>	Ministry Of Heavy Industries And Public Enterprises
<b>Department Name</b>	Department Of Heavy Industry
<b>Organisation Name</b>	Bharat Heavy Electricals Limited (bhel)
<b>Office Name</b>	10410005-pc Chennai
<b>Total Quantity</b>	1
<b>Item Category</b>	BOQ
<b>Minimum Average Annual Turnover of the Bidder</b>	2 Lakh (s)
<b>Years of Past Experience required</b>	3 Year (s)
<b>MSE Exemption for Years of Experience and Turnover</b>	No
<b>Startup Exemption for Years of Experience and Turnover</b>	No
<b>Document required from seller</b>	Experience Criteria,Bidder Turnover,Certificate (Requested in ATC),Compliance of BoQ specification and supporting document *In case any bidder is seeking exemption from Experience / Turnover Criteria, the supporting documents to prove his eligibility for exemption must be uploaded for evaluation by the buyer
<b>Bid to RA enabled</b>	Yes
<b>RA Qualification Rule</b>	H1-Highest Priced Bid Elimination
<b>Time allowed for Technical Clarifications during technical evaluation</b>	2 Days
<b>Evaluation Method</b>	Total value wise evaluation

**EMD Detail**

Required	No
----------	----

**ePBG Detail**

Required	No
----------	----

## Splitting

Bid splitting not applied.

1. The minimum average annual financial turnover of the bidder during the last three years, ending on 31st March of the previous financial year, should be as indicated above in the bid document. Documentary evidence in the form of certified Audited Balance Sheets of relevant periods or a certificate from the Chartered Accountant / Cost Accountant indicating the turnover details for the relevant period shall be uploaded with the bid. In case the date of constitution / incorporation of the bidder is less than 3-year-old, the average turnover in respect of the completed financial years after the date of constitution shall be taken into account for this criteria.
2. Experience Criteria: In respect of the filter applied for experience criteria, the Bidder or its OEM {themselves or through reseller(s)} should have regularly, manufactured and supplied same or similar Category Products to any Central / State Govt Organization / PSU / Public Listed Company for number of Financial years as indicated above in the bid document before the bid opening date. Copies of relevant contracts to be submitted along with bid in support of having supplied some quantity during each of the Financial year. In case of bunch bids, the category of primary product having highest value should meet this criterion.
3. Estimated Bid Value indicated above is being declared solely for the purpose of guidance on EMD amount and for determining the Eligibility Criteria related to Turn Over, Past Performance and Project / Past Experience etc. This has no relevance or bearing on the price to be quoted by the bidders and is also not going to have any impact on bid participation. Also this is not going to be used as a criteria in determining reasonableness of quoted prices which would be determined by the buyer based on its own assessment of reasonableness and based on competitive prices received in Bid / RA process.
4. Reverse Auction would be conducted amongst all the technically qualified bidders except the Highest quoting bidder. The technically qualified Highest Quoting bidder will not be allowed to participate in RA. However, H-1 will also be allowed to participate in RA in following cases:
  - i. If number of technically qualified bidders are only 2 or 3.
  - ii. If Buyer has chosen to split the bid amongst N sellers, and H1 bid is coming within N.
  - iii. In case Primary product of only one OEM is left in contention for participation in RA on elimination of H-1.
  - iv. If L-1 is non-MSE and H-1 is eligible MSE and H-1 price is coming within price band of 15% of Non-MSE L-1
  - v. If L-1 is non-MII and H-1 is eligible MII and H-1 price is coming within price band of 20% of Non-MII L-1

## BOQ ( 1 pieces )

Brand Type	Unbranded
------------	-----------

## Technical Specifications

<b>Specification Document</b>	<a href="#">View File</a>
<b>BOQ Document</b>	<a href="#">View File</a>

Advisory-Please refer attached BOQ document for detailed consignee list and delivery period.

## Consignees/Reporting Officer and Quantity

S.No.	Consignee/Reporting Officer	Address	Quantity	Delivery Days
1	Billa Kumar Gangaraju	620014,Ward 55, BHEL Trichy Stores, Tiruchirappalli - 620014.	1	90

## Buyer Added Bid Specific Additional Terms and Conditions

1. Scope of supply (Bid price to include all cost components) : Only supply of Goods
2. Bidder shall submit the following documents along with their bid for Vendor Code Creation:
  - a. Copy of PAN Card.
  - b. Copy of GSTIN.
  - c. Copy of Cancelled Cheque.
  - d. Copy of EFT Mandate duly certified by Bank.
3. OPTION CLAUSE: The Purchaser reserves the right to increase or decrease the quantity to be ordered up to 25 percent of bid quantity at the time of placement of contract. The purchaser also reserves the right to increase the ordered quantity by up to 25% of the contracted quantity during the currency of the contract at the contracted rates. Bidders are bound to accept the orders accordingly.
4.
  1. The Seller shall not assign the Contract in whole or part without obtaining the prior written consent of buyer.
  2. The Seller shall not sub-contract the Contract in whole or part to any entity without obtaining the prior written consent of buyer.
  3. The Seller shall, notwithstanding the consent and assignment/sub-contract, remain jointly and severally liable and responsible to buyer together with the assignee/ sub-contractor, for and in respect of the due performance of the Contract and the Sellers obligations there under.
5. Bidders are advised to check applicable GST on their own before quoting. Buyer will not take any responsibility in this regards. GST reimbursement will be as per actuals or as per applicable rates (whichever is lower), subject to the maximum of quoted GST %.
6. While generating invoice in GeM portal, the seller must upload scanned copy of GST invoice and the screenshot of GST portal confirming payment of GST.
7. Bidder's offer is liable to be rejected if they don't upload any of the certificates / documents sought in the Bid document, ATC and Corrigendum if any.
8. Material Test Certificate Should Be Sent Along with The Supply. The Material Will Be Checked by Buyer's Lab & the Results of the Lab will be the Sole Criteria for Acceptance of the Item.
9. **Nominated Inspection Agency:** On behalf of the Buyer organization, any one of the following Inspection Agency would be conducting inspection of stores before acceptance:  
Pre-dispatch Inspection at Seller Premises (applicable only if pre-dispatch inspection clause has been selected in ATC): BUREAU VERITAS INDIA PVT LTD  
Post Receipt Inspection at consignee site before acceptance of stores: WARD 55, BHEL TRICHY STORES
10. Buyer uploaded ATC document [Click here to view the file.](#)

## Disclaimer

The additional terms and conditions have been incorporated by the Buyer after approval of the Competent Authority in Buyer Organization. Buyer organization is solely responsible for the impact of these clauses on the bidding process, its outcome and consequences thereof including any eccentricity / restriction arising in the bidding process due to these ATCs and due to modification of technical specification and / or terms and conditions governing the bid. Any clause incorporated by the Buyer such as demanding Tender Sample, incorporating any clause against the MSME policy and Preference to make in India Policy, mandating any Brand names or Foreign Certification, changing the default time period for Acceptance of material or payment timeline

governed by OM of Department of Expenditure shall be null and void and would not be considered part of bid. Further any reference of conditions published on any external site or reference to external documents / clauses shall also be null and void. If any seller has any objection / grievance against these additional clauses or otherwise on any aspect of this bid, they can raise their representation against the same by using the Representation window provided in the bid details field in Seller dashboard after logging in as a seller within 4 days of bid publication on GeM. Buyer is duty bound to reply to all such representations and would not be allowed to open bids if he fails to reply to such representations.

[This Bid is also governed by the General Terms and Conditions](#)

In terms of GeM GTC clause 26 regarding Restrictions on procurement from a bidder of a country which shares a land border with India, any bidder from a country which shares a land border with India will be eligible to bid in this tender only if the bidder is registered with the Competent Authority. While participating in bid, Bidder has to undertake compliance of this and any false declaration and non-compliance of this would be a ground for immediate termination of the contract and further legal action in accordance with the laws.

**---Thank You---**

# **General terms and conditions on GeM 3.0 (Version 1.19)**

## **1. Introduction**

This document is an electronic record published by GeM under the provisions of the Information Technology Act, 2000 and the rules made there under (as applicable) and shall act as valid agreement between Seller / Service Provider and Buyer. Further the use of GeM Portal for Sale / Purchase of Goods / Services and the **resulting Contracts shall be governed by the following General Terms and Conditions (GTC) (unless otherwise superseded by Product / Service specific Special Terms and Conditions (STC), Product / Track / Domain Specific STC of Particular Service including its SLA (Service Level Agreement) and BID/Reverse Auction Specific Additional Terms and Conditions (ATC) as applicable).**

Government e-Marketplace (GeM) is the National Public Procurement Portal; an end-to-end online Marketplace for Central and State Government Ministries / Departments, Central & State Public Sector Undertakings (CPSUs & SPSUs), Autonomous institutions and Local bodies, for procurement of common use goods & services. The portal is owned and managed by GeM SPV which is a Section 8 (Non-Profit) Company registered under the Companies Act, 2013. GeM SPV operates, monitors and supervises all the business transactions on the portal through the Managed Service Provider as per defined roles and responsibilities.

## **2. General Terms and Definitions:**

- a. **“APPLICABLE LAWS”** shall mean any statute, law, ordinance, notification, rule, regulation, judgment, order, decree, bye-law, approval, directive, guideline, policy or other governmental restriction as may be in effect.
- b. **“GOODS”** shall mean an Article / product or an intangible product like software, technology transfer, licenses, patents or other intellectual properties being offered for sale on the GeM portal by Seller(s) on GeM. The term ‘Goods’ shall also include works and services which are incidental or consequential to the supply of such goods, such as, transportation, insurance, installation, commissioning, training and guarantee / warrantee obligations as defined in the scope of supply given in the contract.
- c. **“SERVICES”** shall mean the services offered or provided by the Seller such as IT Professional Services, Manpower Services, Security Services, Transport Services, etc. listed as Services on GeM. The term ‘Service’ shall also include supply of goods / articles which are incidental or consequential to the provisioning of such Services as defined in the scope of supply given in the contract.

- d. **“SERVICE LEVEL AGREEMENT (SLA)”** shall mean the Contractual Commitment that prevails between the Buyer and the Service Provider with regard to type of service to be provided, deliverables, desired performance level, reliability and responsiveness, monitoring process and service level reporting, response and issue resolution time-frame, repercussions / penalties / remedies for service provider not meeting its commitment. The SLA of a particular contract may carry the matrix regarding the delivery of the goods and/or services and the corresponding penalties or remedies and liquidated damages as applicable.
- e. **“CATEGORY SPECIFICATION”** shall mean the framework of technical features, functional capabilities, technical properties, certifications of the items etc. in a particular category. The Specifications shall identify the key parameters defining the products with all necessary validations related to configuration, type of data, restrictions, range / allowed values, allowed units etc. Sellers as well as Buyers while offering / buying the Goods / services shall have to comply with the validation rules / restrictions provided for in the Category Specification. Buyers / Sellers can not add parameters and / or drop down values not provided for in category Specification. If any Buyer / Seller desire to add new parameter, value, validation etc. against any category specification, they have to raise request for the same to GeM for incorporation in Category Specification.
- f. **“BUYER”** is the Contract placing authority, which includes Central/State Government Ministries/Departments including its attached/subordinate offices, Central/State Public Sector Units (PSUs) and Autonomous Bodies acting through its authorized officer(s) for and on behalf of President of India/Governor of the State /PSU/Autonomous Bodies, as the case may be, for purchase of Goods/Services offered by Sellers on GeM.
- g. **“SELLER / SERVICE PROVIDER”** on GeM shall mean any legal entity such as firm(s) of Proprietorship / Partnership Firm / Limited Liability Partnership / Private Limited / Limited company / Society registered under Society’s Act / Statutory Bodies etc., registered on GeM to sell its Good(s) / Service(s) to the Buyers registered on GeM.

The “Seller on GeM” will be either OEM (Original Equipment Manufacturer\*) or Seller having authorization to sell products manufactured by the OEM in open market.

\* OEM is the owner of the Brand / Trademark of the product being offered or in case of un-registered brand’s products / products with own brand, the actual manufacturer of the final product. To be recognized as an OEM on GeM, seller has to get Vendor Assessment Report from designated agency (unless exempted as per GeM VA policy) as per due process of vendor assessment notified on GeM portal

(which would include production of documentary evidences and demonstration of manufacturing facilities and / or capabilities as required).

In case of Services related to Goods, Service Provider on GeM will be either OEM or Service Provider having authorization to Service products manufactured by that OEM in open market. In respect of other Services, Service Provider on GeM will be any legal entity offering its services.

By registering on GeM portal , Seller / Service Provider hereby agrees to be bound by these General Terms and Conditions for Sale / Purchase of Goods and / or Services (GTC); Product / Service Specific Special Terms and Conditions (STC) and Service Level Agreements (SLAs) for various Services; and Additional (Bid Specific) Terms and Conditions (ATC) as applicable.

For the purpose of this document and transactions on GeM, Seller as well as Service Provider will be referred to as "Seller"

- h. **"USER ID and PASSWORD"** All users including Buyers and Sellers (primary as well as secondary) will get User ID and Password created on GeM following due registration process defined on GeM. It is the responsibility of the user to keep their User ID and Password secure and confidential. Individual user shall be solely and completely responsible for all transactions taking place on GeM portal using his / her User Id and Password and GeM shall not be responsible in any manner.
- i. **"LICENSE"** shall mean by registering the Seller and by offering Product / Service details on GeM, the Seller grants GeM a non-exclusive, royalty-free, irrevocable, perpetual and fully sub-licensable right to use, reproduce, modify, adapt, publish, translate, distribute, and/or display the content/materials which has been submitted to GeM excluding Aadhaar No. In case of registration of Primary user and creation of secondary user(s) by the Buyer/Seller, their Aadhaar (UID) details collected by GeM are solely for user verification and to apply e-signing on the documents. The e-sign is at par with digital signatures as per Information Technology Act Amendment 2008 and it works based on details available in Aadhaar database of UIDAI and there is no interference / intrusion in their personal details.
- j. **"CONTRACT"** shall mean the purchase order created / issued by the Buyer on GeM for supply of Goods / Services in electronic form which includes scope of supply, delivery instructions and specifications etc. as ordered by Buyer against such Contract besides the subject GTC, STC/ATC as the case may be.

### **3. Role, Responsibilities and Obligations of Seller/ Buyer:**

#### **A. Role and Responsibilities of Sellers on GeM are as under:**

- i. Only Director (s) / Partner (s) / Proprietor (as applicable) are authorized to become Primary User and register any legal entity on GeM as Seller.
- ii. Once Seller/Service Provider is registered and account is created on GeM, the Primary user of the Seller/Service Provider can create Secondary User Accounts within Seller/Service Provider Organization with different Roles and Responsibilities. However, the Primary User creating Secondary User accounts shall continue to be fully responsible and accountable for all actions / transactions done by Secondary Users on GeM Portal.
- iii. Since GeM is a trust based Portal, the complete accuracy and integrity of data submitted in respect of the Seller and also in respect of the Goods / Services offered on GeM will be the sole responsibility of the Seller/Service Provider. Seller will be liable for administrative action as per GeM terms and conditions in case of any discrepancy / infirmity in any data / information submitted on GeM.
- iv. The Primary / Secondary Users of Sellers, offering Goods/Services and/or participating in e-Bidding / Reverse Auction on GeM, must ensure that they have the requisite authorization to enter into contract with Buyer(s) in GeM for and on behalf of the Seller, failing which such Seller as well as the individual(s) shall be vicariously liable for its actions and also for any liability arising out of such actions.
- v. Seller can offer any number of products. However, it will be the sole responsibility of the seller to satisfy themselves regarding possessing the requisites for doing business for the offered product(s). The Sellers are solely responsible for ensuring that there is no violation of any Intellectual Property Rights in their offer for sell / providing service on GeM.
- vi. The Seller should not exercise any corrupt influence on any aspect of contract and commit to take all measures necessary to prevent corruption maintaining complete transparency, integrity and fairness in all activities related to GeM.
- vii. The seller would represent its business on the GeM portal and is mandated to comply with all the terms and conditions of the platform. Sellers would be solely and absolutely responsible for the information provided about their organization, business, products and services on the portal and would be required to produce proof of such information, if requested at any point in time by the Buyer and / or GeM.

- viii. GeM would not allow creation of any fresh data related to Seller identity on GeM portal. All details provided by the Seller at the time of registration would be counter checked / verified through other data bases of Government such as PAN, MCA 21, Udyam Registration etc. For Financial details, PAN / Income tax Database shall be primary validating database and will override any conflicting data in any other database. If the data / details entered by the seller while registering on GeM is not verified with validating databases, registration will not be allowed. Further, in case of any conflict in details after registration, Seller's registration would be automatically suspended. It is the Seller's responsibility to keep all their information on GeM updated with the latest change(s). Non-updating of details on GeM within 7 days of such occurrence would make Seller liable for administrative actions.
- ix. Eligibility of Sellers in terms of Turn Over / Past Performance / Profitability etc. and also their eligibility for availing various benefits / advantages in terms of various Govt. Policies / Guidelines / Acts / Laws etc. shall be determined solely on the basis of data fetched / validated or verified through external agency / owner of that set of database such as IncomeTax / PAN Data Base, MCA 21, Udyam Registration, GSTN, Certifying Agencies such as BIS, BEE etc. In case of any discrepancy in data available in these databases, Seller has to get the same updated in the corresponding validating database before updating the same on GeM. Till such time only the existing validated information shall be used to decide seller's eligibility on GeM. Any default in sellers updating their data on partner sites / validating databases and any fall out of the same impacting adversely any transaction on GeM, shall entirely and exclusively be Seller's responsibility. GeM shall not be responsible for any consequential impact on any GeM transaction due to data discrepancy and / or suspension of seller account due to data discrepancy. Seller will be solely responsible for the same.
- x. The Seller shall be solely responsible for the Goods / Services including, without limitation, the applicable guarantee / warranty, shelf-life, quantity, quality and the title and for giving the correct and accurate details of the offer their Goods and / or /Services indicating product specifications, quantity which can be supplied over the specified time period, etc. as per catalogue or catalogue based template prescribed in GeM. Seller would ensure that the Goods or /Services offered are latest, new and complete in all respects. Where Seller is selling any Goods which needs spare parts, Seller should ensure and make available such spare parts for a minimum

period of three years from the date of expiry of warrantee period (unless otherwise specified). The individual Sellers shall ensure that the products offered in e-Bidding and/or ordered shall remain available on GeM during the bid / contract validity period.

- xi. Sellers shall offer minimum discount of 10% on the Maximum Retail Price (MRP) mandatorily (unless otherwise specified for offering their products on GeM). Sellers are free to offer higher discounts. The Seller must offer its best possible lowest price on GeM and undertake that it would not sell or offer to sell the same product outside GeM in comparable quantity on similar terms and conditions at a price equal to or lower than Offer Price on GeM. In case any such infringement by Seller is noticed, the Seller shall be liable to be removed / debarred from the GeM.
- xii. By offering their product on GeM, the Seller agrees for sharing price details of the offered Goods / Service by GeM authorities with other Government agencies including Department of Excise & Customs, Income tax, GST etc.
- xiii. Listing of Goods / Services in irrelevant / inappropriate categories is strictly prohibited. If any such infringement made by Seller leads to placement of a contract by any Buyer for such inappropriately offered product(s)/service(s) by the Seller, such contract shall be treated as null and void. No claim whatsoever against such contract shall be admissible and entertained.
- xiv. The Seller(s) shall pass on all the benefits associated with any scheme / offer / freebies provided by the OEM on any product from time to time on an "as-is basis" to the Buyer. This obligation will also apply to OEM's directly supplying the goods. Holding back any such offer or accounting such freebies in quantity supplied shall make such consignments liable to be rejected by the consignee and shall also be considered as inappropriate and against the GeM policies for which GeM reserves all rights to take necessary action against such Seller/OEM as deemed fit.
- xv. By registering on GeM and by participating in any bid on GeM, Seller undertakes that presently it is not "Debarred from Bidding" on the grounds mentioned in Rule 151 of GFR 2017.

**B. Role and Responsibilities of Buyer on GeM:**

Buyer Registration on GeM is divided in two categories:

- a. **Primary User:** In GeM , the Primary User is as under:

- i. Any officer of Central / State Government / PSU / Autonomous Bodies / Local Bodies / Constitutional Bodies / Statutory Bodies at the level of Deputy Secretary of the Government of India or equivalent
- ii. Head of the Office at Sub Centre / Unit / Branch, can Register his / her organization / unit on GeM portal as Primary User.

Primary User shall be responsible for registering the organization on GeM, for creating User accounts for Secondary Users, assigning them roles and responsibilities on GeM and for supervision of all transactions performed by Secondary Users under him / her.

Primary User shall also be vicariously responsible for ensuring compliance of General Financial Rules and / or Rules Governing Public Procurement in respect of their organization, all GeM terms and conditions and other Procurement Policies / Guidelines notified by the government from time to time, by all the secondary users including timely payments and for dispute resolutions as per GeM terms and conditions.

Primary user cannot perform any Procurement related transactions on GeM portal.

- b. **Secondary Users:** Secondary Users are officials responsible for procurement transactions on GeM including Placement of Contracts, Receipt of Stores, and Payments to the Sellers etc. The access rights permissible to registered Secondary users would be decided by the Primary User of the Department. Secondary Users may be given the roles of Buyer / Consignee / Drawing and Disbursement Office (DDO) / Paying Authority etc. For transaction on GeM portal, Buyer is the official who is responsible for processing procurement transaction up to Order Placement stage. Consignee is the Secondary User in Buyer Organization responsible for certifying receipt and acceptance of the goods procured.

Buyer's responsibilities on GeM portal are as under:

- i. The Buyers are responsible to ensure that the procurement done by them are in compliance of General Financial Rules and / or Rules Governing Public Procurement in respect of their organization, all GeM terms and conditions and other procurement Policies / Guidelines notified by the government from time to time, including timely payments as per GeM terms and conditions.
- ii. The Buyers (in all capacities i.e. as Buyer, Consignee, DDO, Paying Authority etc) are responsible to ensure that the procurement done by them are in compliance with GeM Terms and Conditions / Guidelines

and all contract related transactions are completed within time lines prescribed in GeM Contract.

- iii. The Buyers must ensure that they have the requisite authorization to enter into contract with Seller(s) on GeM for and on behalf of the organization, failing which such individual(s) shall be individually liable for its actions and also for any liability arising out of such actions.
- iv. While making procurement on GeM, the Buyers shall judiciously search and shortlist items using filters such as quantity, technical parameters, delivery period, warranty period, consignee location(s), Seller's eligibility etc. as per their approved requirements. Placement of contract for a product / service uploaded by the Seller in any wrong/inappropriate product category is strictly prohibited and such contracts shall be treated as null and void and such Buying shall adversely affect Buyer Rating on GeM.
- v. The Buyers shall satisfy themselves that the price of the selected offer is reasonable. Buyer is at liberty to utilize all the data / information and Business Analytics made available in GeM including e-bidding and reverse auction.
- vi. The Buyers, before placing the order on GeM, should have the required mandatory approval with prior sanction and approval of the competent authorities and shall be in compliance with and as per procedures outlined in GFR and other procurement guidelines issued by the Government from time to time.
- vii. On award of the Contract(s), it would be construed that the Buyer has obtained all necessary Administrative & Financial sanctions of the competent authority and adequate funds are available indicating the relevant Head of accounts in the awarded Contract(s).
- viii. The Buyers should not exercise any corrupt influence on any aspect of contract and commit to take all measures necessary to prevent corruption maintaining complete transparency and fairness in all activities related to GeM.
- ix. Buyers are not allowed to place any order at GeM prices outside GeM. The prices on GeM are only applicable if the procurement is made through GeM portal. Using GeM prices for procurement outside GeM portal is strictly prohibited. Further, Buyers are not allowed to place any off-line contract to the Seller directly based on the outcome of e-Bidding

/ RA conducted on GeM. All such contracts shall be treated as null and void and GeM reserves the right to delete all data related to such transactions from GeM database besides taking suitable actions against such Buyers including suspension from GeM and / or reduction of Buyer rating etc.

#### **4. Enabling provisions of Rule 149 of General Financial Rules- 2017**

Enabling provisions of Rule 149 of General Financial Rules- 2017 as amended vide Ministry of Finance OM dated 02.04.2019 regarding procurement through GeM and necessary guidelines and terms and conditions thereon:

GeM portal may be utilized by the Government buyers for on-line purchases as under:-

- i. Up to Rs.25,000/- through any of the available suppliers on the GeM, meeting the requisite quality, specification and delivery period.
- ii. Above Rs.25,000/- and up to Rs.5,00,000/- through the GeM Seller having lowest price amongst the available sellers (excluding Automobiles where limit of Rs.30,00,000/- will be applicable), of at least three different manufacturers, on GeM, meeting the requisite quality, specification and delivery period. The tools for online bidding and online reverse auction available on GeM can be used by the Buyer if decided by the competent authority.
- iii. Above Rs.5,00,000/- through the supplier having lowest price meeting the requisite quality, specification and delivery period after mandatorily obtaining bids, using online bidding or reverse auction tool provided on GeM (excluding Automobiles where limit of Rs.30,00,000/- will be applicable).
- iv. The Government Buyers may ascertain the reasonableness of prices before placement of order using the Business Analytics (BA) tools available on GeM including the Last Purchase Price on GeM, Department's own Last Purchase Price etc.
- v. GFR rule 149 allows direct on-line purchases on GeM up to Rs. 25,000/- through any of the available suppliers on the GeM, meeting the requisite quality, specification and delivery period. However this is subject to procuring authorities certifying the reasonability of rates. While making such direct on-line purchase below Rs. 25,000/-, the buyer should have

approval of competent authority and should also record reasons for selecting the specific product in case lowest priced products are not being accepted / ordered.

- vi. Tools have been deployed on GeM portal to show the price of compared products on other e-commerce sites (wherever available) and also the rates at which orders have been placed on GeM for such items in recent past. While taking decision on reasonableness of price, the buyers may also take into account the discount over MRP; Last Purchase Price on GeM, Department's own Last Purchase Price; rates on other e-commerce websites etc. The prices on e-commerce site give a broad idea and its terms and conditions may be different. If it is found that the price available on GeM marketplace is not reasonable or is substantially higher than e-commerce sites or LPP, the GeM Portal provides tools for online bidding or reverse auction which can be used by the Buyers to get better competitive rates and then satisfy themselves about reasonableness of the price as per GFR -2017 before placement of contract. Bidding should be considered as the preferred mode of procurement above Rs. 25,000/-.
- vii. In case of Direct Purchase, during carting period, rates for carted quantity, for that buyer, are frozen for carting period as notified from time to time on GeM against any upward revision by seller. However, advantage of any downward revision in the offer price of carted item shall be automatically provided to the buyer.
- viii. According to the provisions of Rule 149 (ii) of GFR, 2017, GeM shall be utilized by Government buyers for direct on-line purchases above Rs. 25,000/- and up to Rs. 5,00,000/- however such purchase has to be through the Seller having the lowest price (L-1) amongst the available Sellers on the GeM. In order to ensure that buyers select only L-1 available offer, the GeM portal requires that buyer first compares all the product options available on GeM to ensure that it meets its requirements/ specifications. While comparing, care should be taken that comparison has to be done between products of at least three different Manufacturers / OEMs. For L-1 buying, comparison has to be made between products of at least three different OEMs. If Buyer wants to buy any specific OEM's product then he has to go for Proprietary Article Certificate (PAC) buying after obtaining necessary approvals of competent authorities for PAC buying as per GFR-2017.
- ix. **Proprietary Article Certificate (PAC) Buying:** While making procurement under PAC Buying on GeM, Buyer has to comply with following conditions:

(a) In case a Govt. Buyer on GeM wants to make procurement on proprietary basis on the GeM Portal after obtaining the requisite approvals / PAC certificate from their competent authority as per Rule 166 of GFR-2017, the Buyer can use PAC filter provided on GeM for selecting a specific model/ make available from a particular GeM Seller. As per GFR, Proprietary Article Certificate in the following form should be available with Buyer before procuring the goods under PAC Buying:

(i) The indented goods are manufactured by M/s. ....

(ii) No other make or model is acceptable for the following reasons: .....

(iii) Concurrence of Finance wing to the proposal vide: .....

(iv) Approval of the competent authority vide: .....

(b) The Seller's price on the Portal is just their offer prices and the proper discovery of price generally happens through bidding/RA. Moreover, in PAC procurement irrespective of multiple listing by authorised sellers, the important issue of price control remaining with the OEM cannot be overlooked. Therefore, in case of all the PAC procurements, the Buyers will have to carry out extra due diligence in establishing the reasonableness of prices before placement of contract as per Para (vii) of Rule -149 of GFR-2017.

(c) Except for direct buying up to Rs. 25,000/- subject to establishing the reasonableness of price, the bidding will be mandatory for procurements above Rs. 25,000/-. As result of bidding, the response could be as under:

i. Only OEM is available or only single authorised seller is available.

ii. OEM as well as multiple authorised Sellers are available.

iii. Multiple authorised Sellers of the OEM are available.

(d) After bidding, under PAC buying, the Buyer may take decision with the approval of the competent authority to process the

procurement subject to establishing the reasonableness of prices before placement of contract as per Para (vii) of Rule - 149 of GFR-2017.

- x. In order to give flexibility to the buyers in sourcing their requirements through GeM, provision has been made in e-bid and RA modules for indicating delivery period in terms of “number of days from date of placement of contract”. While stipulating delivery period in their bid documents, Buyers are advised to be careful since un-realistic delivery period stipulations may result in elimination of some genuine sellers, lack of competition and may ultimately have impact on cost of procurement. While fixing delivery period in e-bid/ RA bid, buyers should not only take into consideration the quantity required and the essentiality of requirement of that quantity within stipulated time period but also the possible impact of shorter delivery period on competition in e-bidding / RA.
- xi. Splitting of demands by creating multiple Bids / RAs of same goods / services or making repeated procurements of same Goods / Services through L-1 buying as per rule 149(i) and 149(ii) of GFR-2017 are strictly prohibited on GeM. Splitting of demand deprives the organizations from achieving the best competitive prices leveraging economies of scale. It also implies avoiding the necessity of obtaining the sanction of higher authority required with reference to the estimated value of the total demand. It is a violation of Para Rule 149 (viii) of GFR -2017 and terms and conditions of GeM Portal and Buyer including the Primary Buyer shall be entirely responsible for the same. If any such splitting of demand is noticed, GeM shall have the right to take necessary action such as blocking of such Bids/RAs and / or cancelling such contracts.
- xii. GeM is a dynamic online marketplace. The product/service listings across the existing categories are dynamic. Moreover, new categories of products/services are continuously being added on GeM. In situations where there is only one offer available in a product/ service category and/or there is offer from only one Seller after filter based search, the buyer should not select such offer for buying. Efforts should be made by Buyer to get their past suppliers and prospective Sellers on-boarded on GeM so as to ensure availability of sufficient Sellers on GeM. This however will not apply for PAC procurement.
- xiii. e-Bidding and Reverse Auction (RA) on GeM**

- (a) The e-Bidding / RA module of GeM is a tool provided to the Buyer(s) for organizing bidding / RA from GeM Sellers of the particular product category for a pre-defined requirement i.e. quantity, technical parameters for Goods/ Services of the particular product category required for one or more Buyers / Consignees.
- (b) Prior to initiating e-Bidding / RA, the Buyer shall judiciously search and shortlist item among the items offered on GeM using filters such as quantity, technical parameters, warranty period, consignee location(s) etc. as per the requirement. In case the search made using actual quantity required, fails to identify sufficient offers, the Buyer may use an indicative quantity for initial search and selection of product and quantity may be amended to match the actual requirement at the time of finalizing e-Bidding / RA.
- (c) The technical parameters and warranty of the item identified by the Buyer shall be base parameters of the item for conducting e-Bidding / RA for the required Goods/Services.
- (d) The e-Bidding / RA document will be finalized by the Buyer(s) by stipulating requirements such as Quantity, Consignee Details, Terms of Delivery, Delivery Period, EMD, Performance Bank Guarantee, Time & Date for Start and End of Bid Submission and for Opening of Bids and required Bid Validity period etc. GeM system shall decide Start / Reference Price and Step Value of Decrement in case of RA based on product selection and / or outcome of bidding process.
- (e) Bid Life Cycle: Bid Life Cycle is the period within which a buyer has to complete the entire life cycle i.e. technical evaluation, financial evaluation and order creation of Bid process. By default, it is 90 days from the date of Bid publication. This can be configured to 120 / 150 or 180 days in exceptional cases through catalogue Management System (CMS) for a particular product category (not for a particular Buyer or Bid).
- (f) The e-Bidding / RA invitation / Notice shall be published on GEM, stipulating the last date for bid submission / opening of bids giving at least clear 10 days time after the publication. Any change in last date for bid submission will be intimated to

eligible bidders through e-mail / GeM. The e-Bidding invitation shall be extended to all the registered Sellers on GeM who have Goods / Services for that particular category listed on GeM, at least 2 hours prior to closing time of e-Bidding / RA. The GeM normally requires 48 hrs for approval / rejection of the product / service offered by Sellers before it is listed on the portal. Considering these time lines, the Sellers are required to offer their Goods / Services on GeM well in advance before bid closure. The decision of the Buyer/GeM regarding technical/commercial eligibility of the individual Seller to be invited for e-Bidding / RA shall be final.

- (g) The Seller participating in the e-bidding / RA may offer any one of their product(s) already listed on GeM. The bid submitted under e-Bidding / RA shall remain valid for 15 days (or as stipulated by the Buyer in the bid document) from the Bid Opening Date (till 24.00 Hrs IST). Bid Validity can be further extended with mutual consent between Buyer and Seller subject to the condition that total Bid Life Cycle cannot go beyond the stipulated time limit as per GeM CMS. The products offered in e-Bidding / RA can not be withdrawn by the Sellers from GeM during the bid validity period. The Buyer reserves the right to postpone/cancel the e-bidding and intimation thereof will be sent by e-mail / GeM to the Bidders. Any amendment / corrigendum to the e-bid invitation issued by the Buyer will be made online and shall be uploaded on the GeM. The participation by the Seller in e-bidding shall be construed as his / her acceptance for all the Terms and Conditions as outlined in the e-bidding including GTC, STC and ATC. However, the Buyer shall have right to decide the technical and commercial acceptability of the individual bids based on eligibility criteria and compliances as stipulated in the bid document. The technical parameters shown in the bid are from a particular catalogue as selected by the buyer while applying initial filters in selection of the product. The sellers are free to bid for same, equivalent or superior specifications catalogue / products. In the public interest, buyers will evaluate such bids based on their requirements / end use and

bid parameters and will accordingly technically accept or reject the bids on merits.

- (h) In bid documents, Buyers can incorporate suitable eligibility criteria and additional terms and conditions only using various filters and ATC module available in e-bidding / RA modules of GeM. Buyers are not allowed to incorporate eligibility criteria and / or additional / special terms and conditions exterior to the GeM portal by making reference to any other website / documents etc.
- (i) In case, two or more acceptable bidders are found to have quoted identical lowest bid price, Buyer has to conduct Reverse Auction for the required Goods among all technically qualified bidders in case of bids for Goods. In case of Services bids, if the multiple L-1 bidders have quoted the lowest allowed price for that service, Buyer shall have two options for placement of Contract:
  - a) Placement of contract by selection of an agency from amongst the L-1 bidders through a Random Algorithm run by GeM system.
  - b) Placement of contract on any one of the L-1 bidders based on any criteria as deemed fit by the Buyer with appropriate internal approvals
- (j) The Buyer reserves the right to accept/reject any bid including the lowest bid received through e-bid and/or annul the e-bidding process.
- (k) The participating bidders shall not disclose details of their bids or other details of their e-bids to other bidders or indulge in any anti-competitive behaviour including price manipulation in violation of Competition Act, 2002.
- (l) The Buyer/GeM will not be held responsible for consequential damages such as no internet connection, no power supply, system problems, loss of electronic information, power interruption etc.
- (m) Against any bidding or RA conducted on GeM, if a bidder quotes Nil Charges/consideration, the bid shall be treated as non-responsive and will not be considered.

(n) There shall be no EMD for Bids / RA having estimated value less than Rs. 5 lakh. For bids / RA having estimated value more than Rs 5 Lakh, while finalizing e-Bid / RA, Buyer shall indicate the exact amount of EMD required to be submitted by bidders in the form of Bank Guarantee on GeM portal in the prescribed format. Scanned copy of the same shall be uploaded by Seller in the online bid and hard copy of the same will have to be submitted directly to the Buyer within 5 days of bid opening. GeM recommends quantum of EMD @ 1% of estimated value of procurement. The Buyer also has the option to select EMD between 0.5% to 5%. The same should be valid for 45 days beyond the bid validity. Following categories of Sellers shall however, be exempted from furnishing EMD:

- i. Micro and Small Enterprises who are manufacturer of the Primary Product Category or Service Provider of the Primary Service Category and give specific confirmation to this effect at the time of bid submission and whose credentials are validated online through Udyam Registration and through uploaded supporting documents.
- ii. Start-ups as recognized by Department of Industrial Policy and Promotion (DIPP).
- iii. KVIC, ACASH , WDO, Coir Board, TRIFED and Kendriya Bhandar.
- iv. Sellers who have got their credentials verified through the process of Vendor Assessment by Vendor Assessment Agencies for the Primary Product / Primary Service for which Bid / RA has been invited.
- v. Sellers/ Service Provider having annual turnover of Rs 500 Crore.
- vi. Micro and Small Enterprises registered with NSIC for the Primary Product Category whose credentials are validated through NSIC database and through uploaded supporting documents.
- vii. Micro and Small Enterprises registered with DIC for the Primary Product Category whose credentials are validated through DIC database and through uploaded supporting documents.

- viii. Sellers / Service Providers holding BIS License for the Primary Product Category whose credentials are validated through BIS database and through uploaded supporting documents.
  - ix. Central / State PSUs.
  - x. Seller / Service Provider registered with designated Agency / Authority as specified in the bid document by the Buyer – such bidder shall have to upload scanned copy of relevant registration document in place of EMD document while bidding.
- (o) EMD submitted by the bidder shall be forfeited, if the bidder:
- i. Withdraws or modify or impairs or derogates from the bid in any respect within the period of validity of its bid; or
  - ii. If it comes to notice that the information / documents furnished in its bid is false, misleading or forged; or
  - iii. Fails to furnish requisite performance security / PBG within stipulated time required as per e-bid / RA conditions.
- (p) Notwithstanding above, GeM SPV / GeM Admin also reserve the right to debar such seller from GeM portal. Such debarment shall be for minimum 3 months initially on first such offence and on repeat offence, the debarment period can be increased suitably by GeM SPV / GeM Admin. By submitting a bid on GeM, the Bidder explicitly undertakes to abide by the above clause.
- (q) Earnest money of unsuccessful bidders shall be returned within 15 days after the award of contract or expiry of bid validity whichever is earlier. Earnest money of successful bidder shall be returned within 15 days after receipt of Performance Security / e-PBG.
- (r) In case of RA, Start / Reference Price and Step Value of Decrement shall be indicated to the Bidders at the start of the auction. Any participating bidder can bid one or multiple Step Decrement lower than the prevailing Lowest Bid at that time.
- (s) The Bidder shall be able to view Bid Start Price, Bid Decrement Value, Prevailing Lowest Bid value and last Bid Placed by him. Whenever a lower price bid is received in the closing moment

i.e. within 15 minutes of existing end time of Reverse Auction, the end time of reverse auction shall be extended automatically by another 15 minutes. All participant sellers of that RA shall be notified by the GeM system about extension of time through email and/or SMS and they shall be allowed to submit revised bid under the RA. The same process shall be repeated, if there is another lower bid received in the RA during last 15 minutes of RA.

(t) GeM / Buyer shall not have any liability to bidders for any interruption or delay in access to the GeM site / Reverse Auction link etc, irrespective of the cause.

(u) By creating a bid on GeM, the Buyer undertakes as under:

"I confirm that this tender document complies with the "Public Procurement (Preference to Make in India) Order, 2017" issued by DIPP and "Public Procurement Policy for Micro and Small Enterprises (MSEs) Order, 2012" issued by MoSME".

(v) **Bid to RA:** While creating bid on GeM, Buyer shall have the provision to select Bid to RA option. If this option is selected by the Buyer at the time of bid creation, Sellers would be required to submit their Technical and Commercial bids before bid closure. After completion of technical evaluation by the Buyer, Reverse Auction would be conducted amongst first 50% of the technically qualified bidders arranged in the order of prices from lowest to highest. Number of sellers eligible for participating in RA would be rounded off to next higher integer value if number of technically qualified bidders is odd (e.g. if 7 bids are technically qualified, then RA will be conducted amongst L-1 to L-4). In case number of technically qualified bidders are 2, RA will be between both without any elimination.

In case Primary products of only one OEM are left in contention for participation in RA based on lowest 50% bidders qualifying for RA, the number of sellers qualifying for RA would be increased to get at least products of one more OEM (directly participated or through its reseller) if available. Further, if bid(s) of any seller(s) eligible for SME preference is / are coming within price band of 15% of L-1 or if bid of any seller(s)

eligible for Make in India preference is / are coming within price band of 20% of L-1, then such SME / Make in India seller shall also be allowed to participate in the RA process. After the RA process, the award of contract(s) shall be made by the buyer keeping in view the Public Procurement Policy for Micro and Small Enterprises (MSEs) Order, 2012 and Public Procurement (Preference to Make-in-India) Order, 2017 last revised on 29.5.2019 as amended from time to time.

- (w) In case any Seller / Service provider has been debarred in any particular Department / Organization, Buyers of that particular Department / Organization only shall have the right to disqualify such Sellers / Service providers at the time of technical evaluation of Bids during the period of debarment, subject to the condition that orders of such debarment has been taken with approval of Competent Authority of that Department / Organization and has been communicated to the concerned Seller / Service Provider before bid opening date.
- (x) GeM is an end to end on-line procurement portal and not a tender publishing portal. GeM has detailed GTC, product / service specific STC and a rich ATC library in-built in the portal which can be used to create a comprehensive bid document. Based on the available terms and conditions, there is hardly any need to add any additional conditions to be attached with any GeM bid. However, for inclusion of some clause which is considered absolutely necessary for that particular bid for reasons to be explained in detail, a provision for inclusion of additional conditions in the bid through corrigendum is available in Request Management System. Only indispensable conditions that are not covered in and are not in conflict with GeM GTC, Product / Service STC and the standard ATC library, and which are in compliance with the Govt. orders on Public Procurement and are not restrictive and not against the core principals of transparency, fairness and efficiency enshrined in GeM, can be requested through RMS ATC request for making part of GeM bid through corrigendum. Each such request has to be made only after due approval of the Competent Authority in Buyer Organization confirming that the request has been made with the approval of the Competent

Authority. Buyer organization shall be solely responsible for the impact of the requested clauses on the bidding process and its outcome. The clauses which are already covered in standard ATC library available on GeM Portal, will not be allowed through RMS.

- (y) **Determination of eligibility in case of products requiring BIS License:** In case the bid requires availability of BIS License, bidder has to upload currently valid and operative BIS License copy (Valid on the date of bid opening) to be considered eligible. Submitted BIS License may be in the name of Bidder / OEM or in the name of the Manufacturer to whom the OEM has outsourced manufacturing of his brand of product. The name of the Brand of the offered product should be mentioned in the BIS License. BIS certificate issued under Compulsory registration Scheme for electronic products to OEM/Brand owners for the products marketed under their brand name wherein their products are manufactured at third-party manufacturing unit is valid and is allowed for participation in the bids floated on GeM. The Manufacturer's Authorization in all such cases wherein the manufacturing is done by a third party shall be issued by the Brand owner / OEM and not by the third-party manufacturing unit mentioned in the BIS certificate.
- (z) **Bid Splitting:** In case of critical / vital / safety / security nature of the item, and / or large quantity under procurement and / or urgent delivery requirements and / or inadequate vendor capacity, Buyer may decide to have more than one source of supply. In such cases Buyer may opt for Bid Splitting while creating the bid on GeM, clearly indicating the Bid Splitting ratio in which order will be split among L-1, L-2, L-3 etc as per ratio of splitting pre-disclosed in the bid . After technical and financial evaluation, before splitting the quantity, it should be ensured by the Buyer that the L1 price is reasonable. After deciding the acceptable reasonable price, L1 would be awarded contract for at least the first / highest percentage indicated in the bid splitting ratio. For the rest of the bid quantity, the L-1 rates / lowest accepted rate will be counter offered to the next higher quoting bidder(s) for price matching. On acceptance of the counter offer, the order will be placed on next higher

quoting bidder(s) for the respective percentage. In case of non-acceptance of the counter offer by the next higher quoting bidder(s), a similar offer shall be made to L3 and L4, and so on. In case counter offered rates are not accepted for ratio of splitting quantity as per bid document by any of the subsequent bidders, the left over quantity will be divided between bidders who have accepted the rates in the ratio of their originally allocated quantities subject to their confirmation and after getting consent on mutually agreed delivery schedule for the additional quantity.

## 5. Contract(s):

Following documents shall be construed to be part of the contract generated through GeM:

- i. Scope of supply including price as enumerated in the Contract Document.
- ii. General Terms and Conditions (GTC).
- iii. Product / Service specific Special Terms and Conditions (STC).
- iv. Product / Track / Domain Specific STC of Particular Service including its SLA (Service Level Agreement)
- v. Bid / RA specific Additional Terms and Conditions (ATC).

The Terms and Conditions stipulated in STC & SLA will supersede those in GTC and Terms and Conditions stipulated in ATC will supersede those in GTC and STC in case of any conflicting provisions.

## 6. Prices:

- i. **Offer price on GeM portal:** The prices of the offered Goods or Services shall be firm and fixed at any point of time and shall be indicated in INR for each accounting unit. The Seller can choose to offer Goods or Services with uniform all inclusive unit price for deliveries at locations across India on All India basis or for specified locations selected at the time of product listing. As such, for supply of Goods contract, no additional charges such as local levies / transportation / loading unloading charges etc., shall be payable over and above the contract price. For selected freight intensive products, as notified on GeM, the Seller may quote unit price inclusive of GST with delivery charge(s) (including transportation, loading unloading and local levies) payable extra as defined in the relevant categories. In

respect of items requiring installation and / or commissioning and other services (as indicated in technical details of the item), the charges for the same shall also be included in the offered price on GeM.

Once a Buyer carts a particular quantity of offered Goods / Service, during carting period as notified from time to time on GeM, rates for carted quantity, for that buyer, are frozen for the period as specified on the portal against any upward revision by seller. However, advantage of any downward revision in the offer price of carted item shall be automatically provided to the buyer.

- ii. **Offer price in e-bidding:** Bidder is required to indicate offer price in the price schedule as provided in the bidding document. Complete breakup of price as required must be indicated. However evaluation of the bid shall be on the basis of total all inclusive, landed price at consignee destination (unless otherwise specified in the ATC).
- iii. **Offer price in RA:** Bidder is required to indicate total offer price. Evaluation of the bid shall be on the basis of total all inclusive, landed price at consignee destination (unless otherwise specified in the ATC). Successful bidder shall have to provide complete breakup of the quoted price in the required price bid format before award of contract.

## **7. Performance Security and Performance:**

- i. *There shall be no Performance security / PBG requirement for contracts:*
  - a) *Placed under Direct Purchase / L-1 Purchase Option under Para (i) and (ii) of GFR rule 149;*
  - b) *Placed through Bids / RA with estimated bid value up to Rs 5 Lakh (in case of Goods contracts); and*
  - c) *Placed through Bids / RA with estimated bid value up to Rs 5 Lakh (in case of Services contracts)*
- ii. In case of contracts placed following e-Bidding / RA, Performance Security / Performance Bank Guarantee (PBG) (in format provided on GeM) valid for 2 months beyond the date of completion of all contractual obligations including warrantee obligations, will be obtained from the successful Bidder, for ensuring due performance of the contract. GeM recommends quantum of Performance Security @ 2% of the value of contract. The Buyer also has the option to select Performance Security between 2% to 10%. While finalizing e-Bid / RA, Buyer shall indicate the % of Performance Security required to be submitted by successful bidders. In case of any extension of contract

obligation period, the seller shall be liable to suitably extend the validity of the Performance Security.

Such Performance Bank Guarantee, in prescribed format, from a scheduled commercial bank must be submitted by Seller to the Buyer within 15 days of award of contract on GeM. The payments to the seller shall become due only after receipt of Performance Bank Guarantee by the Buyer and verification of its genuineness.

If the Seller fails or neglects to observe or perform any of his obligations under the contract it shall be lawful for the Buyer to forfeit either in whole or in part, the Performance Security furnished by the Seller.

If the Seller duly performs and completes the contract in all respects the Buyer shall, refund the Performance Security to the Seller within 30 days of completion of all contractual obligations by the Seller.

## **8. Duties & Taxes:**

- i. Offer Prices on GeM shall be on all inclusive basis i.e. including all taxes, duties, local levies / transportation / loading-unloading charges etc. In the case of Bid / RA, complete break-up of the quoted price in the required price bid format shall furnished by the Bidder, before award of contract.
- ii. Statutory variation in the rate of GST, taking place between the date of award of contract and the original / refixed delivery period, shall be to the Buyer's account. For claiming any change in price due to such Statutory variation, the seller shall have to lodge claim before the Buyer providing documentary evidence of change in rate of GST taking place after the date of award of contract and the date of supply within the original / refixed delivery period. Buyer shall issue necessary amendment in the contract to enable generation of supplementary invoice or revised invoice as the case may be.
- iii. No increase in price on account of statutory increase in the rate of GST taking place during the period of delivery period extension with liquidated Damages shall be admissible. Nevertheless the Buyer shall be entitled to the benefit of any decrease in price on account of reduction in GST taking place during extended delivery period.
- iv. The Bill Form / On-line invoice shall be generated by the Seller which may inter-alia include the following confirmations from the Seller:

- a. Certified that the Goods and Services Tax (GST) charged on this Bill is not more than what is payable under the provision of the relevant Act or the Rules made there under.
  - b. Certified that the goods on which GST has been charged have not been exempted under the GST Act or the rules made there under and the charges on account of GST on these goods are correct under the provisions of that Act or the Rules made there under.
  - c. Certified that the Seller is registered with above indicated GSTIN as dealer in the State where in their Billing address is located for the purpose of GST.
  - d. The on-line bill form / invoice generated on GeM is not a replacement for the GST invoice. The proper GST invoice as per requirements of GST rules shall be sent by the seller to the buyer / consignee directly along with the Goods / Services as and when deliveries are made to the consignee.
- v. Seller shall comply with all the necessary statutory compliances including but not limited to providing GST invoices or other documentation as per GST Law relating to the supply of Goods or Services, uploading the details of the invoices, payment of taxes, timely filing of valid statutory returns for the tax period in the GST portal. In case the Input Tax Credit of GST is denied or demand is recovered from Buyer on account of any act/ omission of the Seller in this regard, the Seller shall be liable in respect of all claims of tax, penalty and / or interest, loss, damages, costs, expenses and liability that may arise due to such non-compliance. Buyer shall have the right to recover such amount from any payments due to the Seller or from Performance Security, or any other legal recourse from the said Seller. If any tax is required to be paid by the Seller in pursuance of any demand from tax authorities, on account of Seller's suppression of facts, fraud or wilful misstatement of facts while offering the products or submitting the bids, then the same shall not be passed on to Buyer through debit notes or Invoices or Supplementary Invoices and the seller shall be solely liable for payment of the same.

## **9. Integrity Pact:**

All the Users in GeM i.e. Seller as well as Buyer agree not to indulge in any corrupt practices including without limitation any activity or action to influence the transaction on any aspect of contract and commit to take all measures necessary to prevent corruption maintaining complete transparency and fairness in all

activities related to GeM. Users agree to follow and adhere with the Integrity Pact guidelines provided on GeM Portal.

#### **10. Guarantee And Warrantee:**

- i. The Goods/Services supplied under the Contract(s) shall be in accordance with the contract specifications & quality and the Goods shall be brand new and have standard Guarantee/Warrantee for one year period from the date of final acceptance by the consignee unless otherwise specified in category specifications, specific Bid/RA . Seller, at the time of listing their product on GeM portal or offering their products against any Bid / RA, may accordingly provide longer Guarantee/Warrantee period (i.e. more than 1 year) and in such case, Guarantee/Warrantee period stipulation made in category specifications / Bid / RA document, shall prevail over standard Guarantee / Warrantee period of 1 year stipulated in these General Terms and Conditions.
- ii. Notwithstanding the fact that the Buyer or its Quality Assurance Officer may have inspected and/or approved / accepted the said Goods, it is further guaranteed that if during the said guarantee / warrantee period, the Goods be discovered not to conform to the requisite description and quality and/or not giving satisfactory performance or have deteriorated, and the decision of the Buyer in that behalf shall be final and binding on the Seller and the Buyer shall be entitled to call upon the Seller to rectify and/or replace the Goods or such portion thereof as is found to be defective by the Buyer within 7 days. Otherwise, the Seller shall pay to the Buyer such compensations that may arise by reasons of the warranty therein contained. In cases requiring Spares, the Seller guarantees that they will supply Spare Parts, if and when required on agreed basis for an agreed price for a minimum period of three years from the date of expiry of warrantee period (unless otherwise specified in STC / ATC). The agreed basis could be, including but without any limitation, an agreed discount on the published catalogue or an agreed percentage of profit on the landed cost. The aforesaid provisions made specifically for Goods, shall also be applicable for Services to the extent the same are practically possible.

#### **11. Buyer / Consignee's Right Of Rejection (Return Policy):**

- i. The Goods delivered shall bear the self certified Manufacturer's/Seller's Warranty/Guaranty. Buyer / Consignee shall have the right to inspect the supplied Goods themselves and/or through their appointed agency at consignee's own cost, at Consignee's site(s) after receipt and accept or reject

on proper justification any consignment of the Goods received within a period of 10 days (unless otherwise specified in STC or ATC) of receipt of consignment of goods. The date of receipt shall be reckoned from the date of receipt of the Goods as notified in the Provisional Receipt Certificate (PRC) which will be issued online by consignee immediately after receipt of Goods.

- ii. In case of Service contract, the Buyer reserves right to reject the same in conformance with the terms and conditions of the agreed Service Level Agreement (SLA). However, such right to reject services offered by the Seller under the contract shall be exercised by the Buyer within 10 days (unless otherwise specified in STC or ATC) of the date of receipt of the Service. The date & time of start and completion of the Service, shall be indicated by the Seller while raising on-line invoice for a specified period of Service as per Service Level Agreement (SLA). The date of such invoice or the date of completion of the service, whichever is later shall be reckoned as date of receipt of the Service.
- iii. On Acceptance / Part Acceptance or Rejection of Goods / Services, Consignee will issue an on line 'Consignee's Receipt cum Acceptance Certificate' (CRAC), which will form the basis of Payments to the Seller.
- iv. No payment shall be made for rejected goods or services. After intimation of the rejection / part rejection by the Buyer/ Consignee, the Seller shall be liable to remove / lift back such rejected Goods within 10 days without any extra charge/cost to the Buyer / Consignee failing which suitable ground rent / warehousing charges would be payable by the Seller to the Buyer /Consignee. If the Seller fails to remove / lift back such rejected Goods within reasonable time period, the Buyer / Consignee shall have the right to dispose off such rejected goods at the risk and cost of the seller.

## **12. Payment Authority and Payment Terms:**

Payments shall be made to the Seller in the manner below:

### **i. For Goods :**

In case of goods, 100% payment will be released within ten (10) days of issue of consignee receipt-cum-acceptance certificate (CRAC) and on-line submission of bills unless otherwise specified in STC / ATC.

### **ii. For Services:**

In case of services, 100% payments on the basis of monthly (unless otherwise specified) bills will be paid within ten (10) days of issue of consignee receipt-cum-acceptance certificate (CRAC) and on-line submission of bills unless otherwise specified in STC / ATC.

### **13. Terms of Delivery:**

All the Goods or Services in the GeM shall be offered on Free Delivery at Site basis including loading/unloading. In respect of items requiring installation, commissioning and other services in the scope of supply (as indicated in respective product category specification / STC / ATC), the cost of the same shall also be included in the offer price.

### **14. Delivery Period**

Seller shall indicate the quantity which can be supplied over the specified time period(s). The Seller would offer these details, which would constitute the part of the awarded Contract(s) in the GeM and would make a binding Contract between the Seller & the Buyer. Any modification thereto shall be mutually agreed and incorporated in the Contract. This Delivery Period/Time shall be deemed to be essence of the Contract and delivery must be completed not later than such date(s).

### **15. Extension of Delivery Period and Liquidated Damages:**

Buyer may, on the request of the Seller or otherwise, extend the delivery date suitably subject to the following conditions:

- i. The original Delivery Period may be re-fixed by the Buyer without any Liquidated damages subject to Force Majeure conditions mentioned below and also on the ground/reasons of delay attributable to the Buyer / Consignee.
- ii. For other cases, provided the price trend is not lower, the Delivery Period may be suitably extended for which an amount equal to the Liquidated Damages for the extended period(s) for delay in the supply of the Goods/Services after the expiry of contract delivery period /re-fixed delivery period, shall be recovered from the Seller as mentioned hereinafter for the extended period. No increase in price on any ground after the original/re-fixed delivery date shall be admissible during such extended period(s). Nevertheless the Buyer shall be entitled to the benefit of any decrease in price on account of reduction in GST taking place during extended delivery period.

iii. **Liquidated Damages:** If the Seller/Service Provider fails to deliver any or all of the Goods/Services within the original/re-fixed delivery period(s) specified in the contract, the Buyer will be entitled to deduct/recover the Liquidated Damages for the delay, unless covered under Force Majeure conditions aforesaid, @ 0.5% of the contract value of delayed quantity per week or part of the week of delayed period as pre-estimated damages not exceeding 10% of the contract value of delayed quantity without any controversy/dispute of any sort whatsoever.

iv. **Force Majeure Conditions :**

If at any time during the continuance of the Contract, the performance in whole or in part by either party of any obligation under this Contract shall be prevented or delayed by the reasons of any war, hostility, acts of the public enemy, epidemics, civil commotion, sabotage, fires, floods, explosion, quarantine restrictions, strikes, lockouts or act of God provided notice of happening of such event duly evidenced with documents is given by one party to the other within 10 days from the date of occurrence thereof, neither party shall be by reasons of such event, be entitled to terminate the Contract nor shall either party have any claim for damages against the other in respect of such non-performance or the delay in performance, and deliveries under the contract shall be resumed as soon as practicable after such event has come to an end or ceased to exist, and the decision of the Buyer as to whether the deliveries have been so resumed or not, shall be final and conclusive, Provided further that if the performance in whole or part of any obligation under this contract is prevented or delayed by reason of any such event for a period exceeding **10 days**, either party may at its option terminate the contract provided also that the Buyer shall be at liberty to take over from the Seller at a price to be fixed by Buyer, which shall be final, all unused, undamaged and accepted material, bought out components and Goods in course of manufacture in the possession of the Seller at the time of such termination or such portion thereof as the Buyer may deem fit excepting such materials, bought out components and Goods as the Seller may with the concurrence of the Buyer elect to retain.

## **16. Dispute Resolution Between Buyer and Seller:**

### **AMICABLE SETTLEMENT:**

In the event of any question, dispute or difference arising connection with the Contract, the Parties shall use their respective reasonable endeavour to settle any dispute amicably. If a Dispute is not resolved within 30 days after written notice of

any dispute by one Party to the other, the same shall be resolved through the mechanism of a co-ordination committee to be formed by the Buyer and Seller/Service Provider and to be chaired by the Primary User of Buyer Organization/Department along with representatives from Buyer Department and Seller.

**ARBITRATION:**

In the event of any question, dispute or difference arising under the terms and conditions of the contract placed through GeM, the same shall be referred to the sole arbitration by an officer nominated as Arbitrator by the Primary Buyer of the concerned Buyer Organization. It will be no objection that the arbitrator is a Government Servant and that he had to deal with the matters to which the contract relates or that in the course of his duties as a Government servant he has expressed views on all or any of the matters in dispute or difference. The award of the arbitrator shall be final and binding on the parties to the contract. The arbitration shall be governed as per Indian Arbitration and Conciliation Act 1996 as amended up to date. The place for arbitration shall be at the place from where contract has been placed by the Buyer or at the place of Primary Buyer as decided by the Primary Buyer.

In the event of the Arbitrator dying, neglecting or refusing to act or resigning or being unable to act for any reason, or his award being set aside by the court for any reason, it shall be lawful for the Primary Buyer to appoint another arbitrator in place of the outgoing arbitrator in the manner aforesaid.

In respect of all contract placed through GeM, the dispute would not be referred or entertained by Micro and Small Enterprise Facilitation Council, Consumer Forum or any other adjudication forum.

All disputes in connection with the Contract, shall be subject to the exclusive jurisdiction of the Court within the local limits of whose jurisdiction, the place from where Contract was issued is situated

GeM SPV would not be a party to any such dispute/matter.

In case any Seller / Service provider makes GeM a party / respondent in any case involving any dispute between Buyer and Seller arising out of a concluded contract or arising out of bidding process initiated / concluded by the Buyer on GeM, it would be obligatory on the part of the Buyer to represent GeM also through their Counsel / Lawyer in the proceedings before the legal authority and ensure timely filing of replies / affidavits etc provided by GeM also through their Counsel / Lawyer before the concerned legal authority during the course of

litigation. A standard reply on behalf of GeM, covering following aspects shall be incorporated in all replies / affidavits filed by the Buyer in such cases:

*“Government e-Marketplace is a National Public Procurement Portal; an end-to-end online Marketplace for Central and State Government Ministries / Departments, Central & State Public Sector Undertakings (CPSUs & SPSUs), Autonomous institutions and Local bodies, for procurement of common use goods & services. Prima facie, the dispute in the present case appears to be between the Buyer and Seller arising out a contract placed / bid created by the Buyer on Government e-Marketplace. As per Clause 16, Clause 17 and Clause 22 of the General Terms and Conditions of Government e-Marketplace (duly accepted by the Buyer and Seller), GeM is not to be made a party to any dispute between the Buyer and the Seller. As such Government e-Marketplace is liable to be deleted from the array of parties.*

*In light of the above, we request your goodself to kindly delete Government e-Marketplace from the array of parties.”*

#### **17. Laws Governing the Contract:**

- i. The contract shall be governed by the laws of India for the time being in force.
- ii. Irrespective of the place of delivery, the place of performance or the place of payment under the contract, the contract shall be deemed to have been made at the registered address of the Buyer and / or Primary Buyer.
- iii. Jurisdiction of Courts: The courts of the place from where the contract has been made shall alone have jurisdiction to decide any dispute arising out of or in respect of the contract.
- iv. GeM SPV would not be a party to any such litigation.
- v. In case any Seller / Service provider makes GeM a party / respondent in any case involving any dispute between Buyer and Seller arising out of a concluded contract or arising out of bidding process initiated / concluded by the Buyer on GeM, it would be obligatory on the part of the Buyer to represent GeM also through their Counsel / Lawyer in the proceedings before the legal authority and ensure timely filing of replies / affidavits etc provided by GeM also through their Counsel / Lawyer before the concerned legal authority during the course of litigation. A standard reply on behalf of GeM, covering following aspects shall be incorporated in all replies / affidavits filed by the Buyer in such cases:

*“Government e-Marketplace is a National Public Procurement Portal; an end-to-end online Marketplace for Central and State Government Ministries / Departments, Central & State Public Sector Undertakings (CPSUs & SPSUs), Autonomous institutions and Local bodies, for procurement of common use goods & services. Prima facie, the dispute in the present case appears to be between the Buyer and Seller arising out a contract placed / bid created by the Buyer on Government e-Marketplace. As per Clause 16, Clause 17 and Clause 22 of the General Terms and Conditions of Government e-Marketplace (duly accepted by the Buyer and Seller), GeM is not to be made a party to any dispute between the Buyer and the Seller. As such Government e-Marketplace is liable to be deleted from the array of parties.*

*In light of the above, we request your goodself to kindly delete Government e-Marketplace from the array of parties.”*

#### **18. Limitation of Liability:**

Notwithstanding anything contained in this agreement, no party will be liable for any special, incidental or consequential damages arising out of or in connection with this agreement or any breach hereof (including for loss of data or profits, or cost of cover), whether or not such party has been advised of the possibility of such damages, and whether under a theory of contract, tort (including negligence) or otherwise; except for liabilities arising out of any violation, misappropriation or infringement of a party's intellectual property rights, or from a breach by either party of its obligation. In no event will either party's aggregate liability arising out of or in connection with this agreement or any breach hereof (whether under a theory of contract, tort (including negligence), warranty or otherwise) exceed the Contract Price entered into the Contract between Buyer and Seller.

#### **19. Termination for Default:**

If the Seller does not perform its obligations within the Delivery Period/Date mentioned in the Contract, the same would constitute the breach of the Contract and the Buyer shall have the right to Cancel or withdraw the Contract for the unsupplied portion after the expiry of the original or re-fixed delivery date or period stipulated in the Contract. Such cancellation of contract on account of non-performance by the Seller would entitle the Buyer to forfeit the performance security besides other actions such as downgrading the Seller's rating or debarment from the GeM for specified period as decided by GeM on merits.

## 20. Closure of Transaction:

After satisfactory completion of all the obligations under the Contract and release of payments for the goods / services, the transaction shall be treated as closed.

## 21. Grounds for Administrative Action

(i) Administrative actions may be taken by GeM against the Buyer or the Seller either suo-moto on the basis of the platform mechanisms identified through analytics or on the basis of a complaint or report made to GeM by any stakeholders or any third party information or upon Court order, inter –alia, for non-adherence to the GeM Website Policies including Terms and Conditions and the Incident Management Policy published on the GeM Website.

(ii) The Seller would be liable for administrative actions such as suspension / debarment / removal from GeM, if they fail to abide by any of the Website Policies including the terms & conditions stipulated in this document and/or on anyone or more of the following grounds:

- (a) Listing the products/services not in the relevant categories and/or listing the same with vague/conflicting product specifications/details and irrelevant product photographs.
- (b) Offering Goods / Services without having proper authorization
- (c) Supplies goods of inferior/ substandard quality
- (d) Supplies or offers to supply refurbished or counterfeit or fake products
- (e) Withdraws or modify or impairs or derogates from the bid in any respect within the period of validity of its bid;
- (f) Seller furnishes inaccurate, false, misleading or forged or fails to furnish any information / documents, within the prescribed time limits, to GeM or to a Buyer, including during e-Bidding/ RA process;
- (g) Fails to furnish requisite performance security / PBG within stipulated time required as per e-bid / RA conditions;
- (h) Fails to update GeM about any change in information furnished within the prescribed time limits;
- (i) Executes services without conforming to requirement given in Service Level Agreement (SLA);
- (j) Fails to execute an order/ contract or fail to execute it satisfactorily
- (k) Is declared bankrupt or insolvent;
- (l) Fails to produce the requisite documents/ information during the course of inspection / assessment at any stage;

- (m) Performs any activity which is listed as prohibited activities on GeM.
- (n) On any other ground for which, in the opinion of GeM, the retention of the seller or any of its offered product in GeM is not in Public Interest.
- (o) The grounds mentioned above are illustrative only. Users are also advised to read the list of prohibited activities published on the website.
- (iii) Notwithstanding anything contained in the GTC, GeM reserves the right to cancel or annul the registration of any Seller or remove any of the Good/Services listed by a Seller on the GeM Website to comply with any provision of the Applicable Laws and / or Court Orders.
- (iv) GeM may take an administrative action in terms of the GeM Website Policies against a Buyer which may include reporting of any breach or misconduct to the Buyer Primary User and/or to the competent authority and GeM reserves the right to review the rating of such Buyer, and / or block Buyer's account for such time as considered appropriate by GeM.
- (v) The Seller and the Buyer understands that the grounds for administrative action as provided under the Contract are only indicative and additional grounds may be provided under the GeM Website Policies including the Incident Management policy. The Seller / Buyer warrants to abide by all additional grounds as may be specified by GeM in the GeM Website Policies from time to time.

## **22. Role of Government E- Marketplace - Gem SPV**

Government e-Marketplace – GeM SPV is the owner of the GeM portal which monitors and supervises all the business transactions on the portal. The role and responsibilities of the company are as under:

- a. To develop, operate and maintain technology driven e-marketplace, through a Managed Service Provider (MSP), to be used by government agencies for procurement of various goods and services in a transparent and efficient manner.
- b. Overall supervision and monitoring of GeM portal operations, policy management, finalization and implementation of various business processes and work flows in adherence with the applicable law and executive orders

issued from time to time . To provide tools for on-line Bidding, on-line Reverse Auction and Business Analytics Tools on GeM.

- c. To work continuously for improvements in the Business Processes and Work Flows for various activities / functions on GeM based on feedback from various stakeholders to enhance transparency, efficiency, competitiveness, equality, economy in procurement of goods and services by government agencies.
- d. To finalize General Terms and Conditions for sale and purchase of Goods and Services on GeM, Product / Service Specific Special Terms and Conditions, Special Terms and Conditions for Bunching of Goods / Services, Bid Specific Special Conditions, Project Specific Special Conditions etc.
- e. To finalize, upload and approve Technical Specification Frameworks for various item / service categories on GeM and to monitor conformity of offered products to the larger framework so finalized and uploaded.
- f. To decide addition / deletion of any of the offered product(s)/Product category (ies) and their framework of technical parameters on GeM.
- g. To work and co-ordinate with different Organizations/Departments / Agencies for integration of their Databases with the GeM portal on real time basis for the purpose of verification/authentication of data entries made by stakeholders.
- h. To offer and manage Demand Aggregation services for identified categories across buyers with assured reasonability of price, recommending for placement of orders by individual buyers
- i. To co-ordinate with MSP for conducting workshops for the various Stakeholders in capacity building and in change management associated with the implementation of technology enabled procurement process.
- j. To monitor MSP that the Buyers, Sellers and Service Providers are being assisted properly by them to onboard their goods and services on the GeM platform.
- k. To identify and offer services of 3<sup>rd</sup> parties for Vendor Assessment relating to technical, financial capacity, past experience of sellers including manufacturing / testing facilities / quality control arrangement(s) of manufacturing premises and/or any of the premises related to manufacturing process of products / services offered by the seller / service provider on GeM.

- l. To identify and offer services of 3<sup>rd</sup> parties for testing and certifying the quality of the product offered/ supplied, through documents, test reports/ certificates, testing at any independent lab or through inspection/testing by its authorized representative/s at firm's premises or at user's premises, that buyer choose to use.
- m. Overall monitoring and management of Call Centre/Help desk operations being provided by the MSP.
- n. Removal / debarring the Sellers/Buyers and Goods / services in GeM.
- o. Management of complaints and their redressal mechanism in GeM (not disputes related to concluded contracts).
- p. To identify, integrate and manage MoUs with verifying, certifying and validating entities across government(s) and also professional agencies to reinforce the online paperless, contactless and cashless system on GeM.
- q. To issue Notices, Circulars, News, Flashes, Updates etc in GeM
- r. Reporting and MIS mechanism in GeM
- s. Any other related activities in the GeM
- t. In exceptional circumstances, for ensuring propriety of procurement processes or to obviate possible misuse of GeM functionalities, GeM SPV as GeM Admin may keep any Bidding / RA process on hold for some time as considered appropriate.
- u. To take approved User Charges from Buyers and Sellers for the various transactions on the GeM portal as decided and notified on the GeM portal.

### 23. Miscellaneous Provisions

- a. **Assignment:** Users understand and agree that the GTC, STC and ATC provisions, rights and obligations granted by GeM are non- transferrable or assignable by the User to any third party, without the prior written consent of GeM. If same is permitted by GeM, all the conditions, rights and obligations of the GTC or any on-going STC/ATC shall also be binding upon such third party assignee besides the User.
- b. **Indemnification:** The Seller shall at all time indemnify Buyer against all suits and claims which may be made in respect of the goods/services for infringement of any right protected by patent, registration of designs or trade mark. Provided always that in the event of any claim and suit in respect of alleged breach of patent, registered designs or trade-mark being

made against the Buyer, the Buyer shall notify the Seller/ Service Provider of the same who shall at its own expense either settle any such dispute or conduct and litigation that may arise there from.

Buyers and Sellers agree to indemnify, defend and hold harmless GeM, its officials, Managed Service Provider (herein after individually and collectively referred to as "indemnified parties") from and against any and all losses, liabilities, claims, suits, proceedings, penalties, interests, damages, demands, costs and expenses (including legal and other statutory fees and disbursements in connection therewith and interest chargeable thereon) asserted against or incurred by the indemnified parties that arise out of, result from, or in connection with

- i. Breach of the contract(s); or
- ii. Any claims made by any third party due to, or arising out of, or in connection with, use of the Website; or
- iii. Any claim made by any third party regarding content/ information or materials provided by Seller cause any damage to a third party; or arising out of, or in connection with, use of the Website.
- iv. Violation of any intellectual property rights or any other rights.

Once GeM notifies the Buyer/ Seller of such claims, they shall defend and indemnify GeM for the same. Further, in no case they shall compromise or settle any claim or admit any liability on the part of GeM without the express or prior written consent of GeM which can be withheld or denied or modified by GeM in its sole discretion or as per the Applicable Laws.

- c. **Severability:** If due to any change in Applicable laws, certain part of the GTC or any applicable STC or any provisions of the GeM policies or portions thereof, becomes unenforceable, the remaining provisions shall continue in full force and effect so as to give effect to the intent of the parties.
- d. **Website Terms and Policies Updation:** Buyers and Sellers are advised to check the website terms and conditions as well as policies such as Privacy Policy and the Website Disclaimer at all times, as GeM may update the Website and such terms from time to time.
- e. **List of Prohibitive Activities (Suggestive And Non-Exhaustive):**

**LIST OF PROHIBITIVE ACTIVITIES:** The following is an indicative list of prohibitive activities which the Buyers and the Sellers registered on GeM platform shall not perform on the GeM platform. A breach of any of the prohibited activities shall give the right to GeM under the Applicable Laws or in terms of these GTC or the GeM Website Policies to take administrative action which may include partial or permanent disabling of account on GeM Website, debarment etc. Additionally, GeM may remove any non-compliant information and reserves the right to preserve and share with the appropriate authority such information and associated records for investigation purposes. The Buyer and the Seller understand that this list is only indicative and additional activities may be prohibited under the GeM Website Policies. The Buyers and the Sellers shall undertake to provide their full support that may be required by GeM for removal and disabling of the non compliant information. The prohibited activities include:

- (i) Indulging in cyber crime or other criminal activities which can become a threat to GeM, GeM Website, to the Government of India or to any State Government or Government Agency.
- (ii) Advertising, exhibiting, representing, publishing, pronouncing, listing, delivering, offering to sell or selling any kind of Goods/Services which can cause any kind of infringement or disparagement of intellectual property rights.
- (iii) Selling refurbished, counterfeit and/or fake Goods / Services under a brand or misusing others brand name.
- (iv) Offering to sell or selling above the MRP any Goods or misrepresenting the MRP.
- (v) Delivering some other Goods or Services instead of the Goods or Services Contracted for or delivering empty parcels or used Goods in breach of the terms of the Contract.
- (vi) Offering to sell or selling freebies which are 'Not for sale' Goods.
- (vii) Listing of the Goods on GeM Website without authorization to sell Goods manufactured by the OEM in open market or without proper authorisation, if any required, for providing the Service.
- (viii) Listing of the Goods or Services is done on GeM Website without guarantee/warranty or without a genuine guarantee/warranty.

- (ix) Listing of the Goods or Services in irrelevant or inappropriate categories or with vague or conflicting specifications or description (including descriptive or pictorial description).
- (x) The Buyer /Seller registering on GeM and/or offering or buying the Goods and/or Services and/or participating in e-bidding/reverse auction on GeM, without the requisite authorization to enter into contract on behalf of the concerned legal entity. Failing which such individual(s) shall be individually liable for its actions and also for any liability arising out of such actions.
- (xi) If any Seller has been debarred from GeM then such Seller or their authorized sellers shall also not be permitted to register and offer/sell their products on GeM and / or participate in Bids / RA on GeM.
- (xii) Using GeM prices for making procurement outside GeM Portal.
- (xiii) Splitting of demands by creating multiple Bids/RAs of same goods / services or making repeated procurements of same goods/services through Direct Purchase / L-1 buying as per rule 149(i) and 9(ii) of GFR-2017.
- (xiv) Uploading goods / services containing information that —
  - (a) belongs to another person and to which the user does not have any right to;
  - (b) is grossly harmful, harassing, blasphemous, defamatory, obscene, pornographic, paedophilic, libellous, invasive of another's privacy, hateful, or racially, ethnically objectionable, disparaging, relating or encouraging money laundering or gambling, or otherwise unlawful in any manner whatever;
  - (c) harm minors in any way;
  - (d) infringes any patent, trademark, copyright or other proprietary rights;
  - (e) violates any law for the time being in force;
  - (f) deceives or misleads the addressee about the origin of such messages or communicates any information which is grossly offensive or menacing in nature;
  - (g) impersonate another person;

- (h) contains software viruses or any other computer code, files or programs designed to interrupt, destroy or limit the functionality of any computer resource;
- (xv) threatens the unity, integrity, defence, security or sovereignty of India, friendly relations with foreign states, or public order or causes incitement to the commission of any cognizable offence or prevents investigation of any offence or is insulting any other nation.
- (xvi) Achieving or trying to achieve illegal access to features on GeM Website not specifically authorised or exceeding the scope of authorized access to or other features of the GeM Website;
- (xvii) Obstructing or causing GeM to lose (in whole or in part) the services provided by any internet service provider ("ISPs") or carrying out any cyber security incident;
- (xviii) Sending unsolicited emails, bulk messaging, auto messaging, junk email, spam and like.

**24. Incident management Policy on GeM:** GeM is a trust based system and self-declaration is the key, along with a strong automated process to penalize any deviant behaviour on part of Sellers / Buyers. For this purpose, deviations from the terms and conditions of procurement on GeM, including general terms and conditions, special and additional terms and conditions and any other relevant Government rules and guidelines, are termed as “deviation”. A deviation can occur while listing the products on GeM, at pre-contract stage, during bidding or at post contract stage on GeM. The mechanism for reporting and initiating action on such deviation has been detailed in the Incident Management Policy available on GeM portal under Resources. All stake holders of GeM shall be bound by the actions as detailed in the Incident Management Policy.

All administrative actions under this Incident management Policy, taken by GeM against any of the stakeholders shall not cause any limitation on the legal and/or contractual remedies including any financial recoveries, available to Buyers/Sellers under the Terms and Conditions of contract and/or GeM policies. In case the Buyer / Seller choose to pursue any of these remedies, GeM shall not be made party to such proceedings / remedial actions taken by Buyer/Seller under the contractual provisions.

**25. Use of Aadhaar Number in GeM:** Purpose of the Aadhaar authentication in GeM is to identify the user using eKYC. GeM has provisioned the option for Sellers and Buyers to provide virtual Aadhaar ID instead Aadhaar number. GeM receives First Name, Last Name, Mobile Number, Email ID, DOB and Gender details. It is used to link the mobile number with the user who is registering on GeM; on which subsequently OTP is sent for

achieving the property of non-repudiation in different artefacts / documents generated on GeM. GeM has provisioned an alternative Identity Information option through PAN based verification to Sellers.

**26. Compliance of Restrictions under Rule 144 (xi) of GFR 2017:** Restrictions on procurement from a bidder of a country which shares a land border with India

- I. Any bidder from a country which shares a land border with India will be eligible to bid in this tender only if the bidder is registered with the Competent Authority.
- II. "Bidder" (Seller / Service Provider) means any person or firm or company, including any member of a consortium or joint venture (that is an association of several persons, or firms or companies), every artificial juridical person not falling in any of the descriptions of bidders stated hereinbefore, including any agency branch or office controlled by such person, participating in a procurement process.
- III. "Bidder from a country which shares a land border with India" for the purpose of this Order means: -
  - a. An entity incorporated, established, or registered in such a country; or
  - b. A subsidiary of an entity incorporated, established, or registered in such a country; or
  - c. An entity substantially controlled through entities incorporated, established, or registered in such a country; or
  - d. An entity whose beneficial owner is situated in such a country; or
  - e. An Indian (or other) agent of such an entity; or
  - f. A natural person who is a citizen of such a country; or
  - g. A consortium or joint venture where any member of the consortium or joint venture falls under any of the above
- IV. The beneficial owner for the purpose of (iii) above will be as under:
  1. In case of a company or Limited Liability Partnership, the beneficial owner is the natural person(s), who, whether acting alone or together, or through one or more juridical person, has a controlling ownership interest or who exercises control through other means. Explanation—
    - a. "Controlling ownership interest" means ownership of or entitlement to more than twenty-five per cent. of shares or capital or profits of the company;
    - b. "Control" shall include the right to appoint majority of the directors or to control the management or policy decisions including by virtue of their shareholding or management rights or

shareholders agreements or voting agreements;

2. In case of a partnership firm, the beneficial owner is the natural person(s) who, whether acting alone or together, or through one or more juridical person, has ownership of entitlement to more than fifteen percent of capital or profits of the partnership;
3. In case of an unincorporated association or body of individuals, the

beneficial owner is the natural person(s), who, whether acting alone or together, or through one or more juridical person, has ownership of

or

entitlement to more than fifteen percent of the property or capital or profits of such association or body of individuals;

4. Where no natural person is identified under (1) or (2) or (3) above, the beneficial owner is the relevant natural person who holds the position of senior managing official;
  5. In case of a trust, the identification of beneficial owner(s) shall include identification of the author of the trust, the trustee, the beneficiaries with fifteen percent or more interest in the trust and any other natural person exercising ultimate effective control over the trust through a chain of control or ownership.
- V. An Agent is a person employed to do any act for another, or to represent another in dealings with third person.
- VI. The successful bidder shall not be allowed to sub-contract works to any contractor from a country which shares a land border with India unless such contractor is registered with the Competent Authority.

Any false declaration and non-compliance of the above would be a ground for immediate termination of the contract and further legal action in accordance with the laws.

**Clause 27: Caution Money Deposit:**

(i) All sellers on GeM are required to deposit a one-time amount as under as caution money:

- a) Seller Turnover less than 1 Crore: Rs 5,000/-
- b) Seller Turn over > 1 Crore but < 10 Crore: Rs 10,000/-
- c) Seller Turn over > 10 Crore: Rs 25,000/-

(ii) The above caution money shall remain at the disposal of GeM SPV. This can be forfeited in part or in full (as per approval of CEO (GeM)) in following circumstances:

- a) Seller rejects or does not accept any Direct Purchase / L-1 Purchase order within defined timelines leading to order auto cancellation.
- b) Failure of the seller in executing any GeM contract or if the Seller fails or neglects to observe or perform any of his obligations under the contract (applicable only in respect of contracts that did not have provision of Performance Security / PBG).

- c) Withdraws any bid submitted on GeM within the period of validity of the bid.
- d) Fails to furnish requisite performance security / PBG as per GeM e-bid / RA conditions.

(iii) In case the Caution Money of any seller is forfeited in full or part and his caution money deposit goes below the threshold indicated in para 1 above, the seller account shall be put on hold till the seller re-coups the caution Money account to required value. Seller's stock will become zero for all categories and seller will not be allowed to update anything till the caution money is topped up to minimum required amount.

(iv) Forfeiture of caution money as per above shall be over and above any other actions taken against such sellers as per GeM Incident Management Policy and shall be without any prejudice to the rights and remedies available to GeM and / or Buyer as per provisions of the relevant contracts.

**Clause 28: CMS 3.0 and OEM - Reseller responsibility matrix:**

GeM has implemented enhanced Catalogue Management System (CMS 3.0) on GeM Portal. The Primary Objective of CMS 3.0 is to offer higher level of ownership & accountability to OEMs & its approved Resellers while maintaining Efficiency, Transparency & Inclusiveness of GeM. Complete and detailed Obligations and Privileges matrix of the different stakeholders in different quadrants is given in CMS document available on GeM Portal and OEMs and Resellers are bound to operate on GeM in compliance with the CMS document as updated from time to time.

1) CMS Quadrant 1 (CMS Q1): Product offers in categories under Q1 will be solely offered by GeM validated OEMs. OEM shall be exclusively responsible for maintaining currency and sanity of catalogue and its offer in the Market Place. OEM shall be absolutely and exclusively responsible and be legally liable for sanity and quality of offers including Warranty and After Sales Service obligations.

2) CMS Quadrant 2 (CMS Q2): OEMs as well as pre-Authorized Resellers can offer products in Q2. OEMs shall operate Market Place subject to providing its complete list of Open market authorized sellers along with formal commitment to list and maintain all appropriate and current Product Catalogue for pairing by its Resellers. OEM shall be absolutely and exclusively responsible and be legally liable for sanity and quality of catalogues including Warranty and After Sales Service obligations. Authorize Resellers shall be responsible for Pairing their offer with the already existing Product Catalogue created by the OEM. However, resellers can Update their Offer Price, Stock and Delivery Locations solely at their own discretion and shall be solely responsible for the same.

3) CMS Quadrant 3 (CMS Q3): Catalogue creation in categories under Q3 can be from OEMs and/or their Authorized Resellers concurrently. In case OEM has not created Product Catalogue, Authorized Resellers of OEMs are also permitted to do the same. However, OEM (when registered on GeM and taken OEM Dashboard) shall be responsible for Validating & verifying the Catalogue uploaded by Reseller, Maintaining the Catalogue by adding/updating the Specifications, MRP etc. specific to catalogue. OEM shall also assume all responsibility and legal liability for sanity and quality of offers including Warranty and After Sales Service obligations. However, resellers can Update their Offer Price, Stock and Delivery Locations solely at their own discretion and shall be solely responsible for the same.

4) CMS Quadrant 4 (CMS Q4): Catalogue creation in categories under Q4 can be done by OEMs as well as by any Reseller also. However, OEM (when registered on GeM and taken OEM Dashboard) shall be responsible for Validating & verifying the Catalogue uploaded by Reseller, Maintaining the Catalogue by adding/updating the Specifications, MRP etc. specific to catalogue. However, there is no requirement of any endorsement or authorization of the reseller by the OEM. Resellers can Update their Offer Price, Stock and Delivery Locations solely at their own discretion and shall be solely responsible for the same. Reseller will also be responsible for providing Replacement Warranty in case of Q4 products and Buyer shall not be required to take up with OEM for any warranty claims.

5) CMS (Special Category) : The Special Category is a specialized segment outside the four quadrants for select few categories that require a customized behavior such as Self-Help Groups (SHG) categories.

In Q3 and Q4, in case of re-sellers, if the reseller has not been approved as an authorized re-seller by the OEM on GeM, the re-seller is required to give an undertaking as under while uploading the product, while accepting any order and while participating in any bid:

“I hereby undertake that I have made arrangements for getting the stores from authorized distributor / dealer / channel partner of the OEM of the offered product. At the time of delivery of goods, I will provide necessary chain documents to prove that the supplied goods are genuine and are being sourced from authorized distributor / dealer / channel partner of the OEM. In case of any complaint from the Buyer / Consignee about genuineness of the supplied products, I shall be responsible for providing genuine replacement supplies.”

By uploading any product on GeM or accepting any order on GeM or by participating in any bid on GeM, the re-seller is deemed to have given above undertaking and is liable for compliance of the same.

Further in view of the on-line verification of Seller credentials by the OEM on GeM platform, there is no need for Buyer to ask for or insist on furnishing of OEM authorization in bids in respect of "OEM verified Catalogue" offered by "OEM Verified Reseller". OEM authorization is also not required to be sought and checked by Buyers in case of bids for products in Q1 or Q2.

#### **Clause 29: One Bid per Bidder**

A Bidder shall submit only one bid in a particular bidding process (unless otherwise allowed in the bid STC / ATC conditions). In case of a holding company having more than one independent manufacturing units or more than one unit having common business ownership / management, only one unit should quote. Similar restrictions shall apply to closely related sister companies. Bidder's sister/ Associated/ Allied concern(s) participating or applying against the same tender, shall lead to disqualification of Bidders. Sister/ Associated/ Allied concern means a company, society, partnership firm or proprietorship firm having one or more common persons as Director/ Partner/ Member/ Owner. A Bidder who submits more than one bid will cause all the proposals submitted in the particular bid to be disqualified. In relation to the above, a person will include firm(s) of Proprietorship / Partnership Firm / Limited Liability Partnership / Private Limited / Limited company / Society registered under Society's Act / Statutory Bodies / any other legal entity, as the case may be, & will be deemed to have submitted multiple bids in a particular bid if a person bids in any of the two formats given below:

- a) individual or proprietorship format and/or
- b) a partnership or association of persons format and/or
- c) a company format

Whereby,

- A company shall for this purpose include any artificial person whether constituted under the Indian laws or of any other country.
- A person shall be deemed to have bid in a partnership format or in association of persons format if he is a partner of the firm which has submitted the bid or is a member of any association of persons which has submitted a bid.
- A person shall be deemed to have bid in a company format if the person holds:
  - a) more than 10% (ten percent) of the voting share capital of the company which has submitted a bid, or
  - b) is a director and / or Key Managerial Personnel of the company which has submitted a bid, or
  - c) holds more than 10% (ten percent) of voting share capital in and/or is a director and / or Key Managerial Personnel of a holding company of that company which has submitted the bid.

By making a bid pursuant to the Tender Documents, the bidder / tenderer shall be deemed to have declared that the bidder / tenderer has not made any other bid or multiple bids as understood or deemed in terms of this clause.

All the bids of a bidder who has submitted multiple bids, as per the clause, shall be rejected and Earnest Money Deposit for all such bids shall be forfeited, not by way of penalty or liquidated damages but by way of reimbursement of the pre-estimated costs likely to be incurred by the buyer towards bidding process and in the scrutiny & evaluation of bids.

In addition to the above, bidders found to be in contravention to the said clause will be liable for administrative actions.

## ADDITIONAL TERMS & CONDITIONS FOR HORIZONTAL AND RISER CLAMP ASSEMBLIES

SI No	BHEL requirement																																																						
1	<p><b>SCOPE OF SUPPLY-</b></p> <p>i) Manufacture &amp; Supply of Horizontal pipe clamp assembly and Riser pipe clamp assembly as per BHEL drawings, QCP 06 &amp; QPG 45.</p> <p>ii) To be despatched to Ward 55, BHEL Trichy Stores</p> <table border="1" style="width: 100%; border-collapse: collapse;"> <thead> <tr> <th style="text-align: center;">Item No</th> <th style="text-align: center;">Material Code</th> <th style="text-align: center;">Item Description</th> <th style="text-align: center;">Qty in Nos</th> <th style="text-align: center;">Assembly drawing Ref &amp; Variant</th> </tr> </thead> <tbody> <tr> <td style="text-align: center;">1</td> <td style="text-align: center;">948219020000</td> <td>HOR CLAMP ASSY CS OD 88.9-VAR02</td> <td style="text-align: center;">595</td> <td style="text-align: center;">2-80-999-99251 Var 02</td> </tr> <tr> <td style="text-align: center;">2</td> <td style="text-align: center;">948219050000</td> <td>HOR CLAMP ASSY CS OD 168.3-VAR05</td> <td style="text-align: center;">291</td> <td style="text-align: center;">2-80-999-99251 Var 05</td> </tr> <tr> <td style="text-align: center;">3</td> <td style="text-align: center;">948219060000</td> <td>HOR CLAMP ASSY CS OD 219.1-VAR06</td> <td style="text-align: center;">610</td> <td style="text-align: center;">2-80-999-99251 Var 06</td> </tr> <tr> <td style="text-align: center;">4</td> <td style="text-align: center;">948219080000</td> <td>HOR CLAMP ASSY CS OD 273-VAR09</td> <td style="text-align: center;">336</td> <td style="text-align: center;">2-80-999-99251 Var 09</td> </tr> <tr> <td style="text-align: center;">5</td> <td style="text-align: center;">948219110000</td> <td>HOR CLAMP ASSY CS OD 323.9-VAR12</td> <td style="text-align: center;">86</td> <td style="text-align: center;">2-80-999-99251 Var 12</td> </tr> <tr> <td style="text-align: center;">6</td> <td style="text-align: center;">948219130000</td> <td>HOR CLAMP ASSY CS OD 355.6-VAR15</td> <td style="text-align: center;">129</td> <td style="text-align: center;">2-80-999-99251 Var 15</td> </tr> <tr> <td style="text-align: center;">7</td> <td style="text-align: center;">948219150000</td> <td>HOR CLAMP ASSY CS OD 406.4-VAR18</td> <td style="text-align: center;">63</td> <td style="text-align: center;">2-80-999-99251 Var 18</td> </tr> <tr> <td style="text-align: center;">8</td> <td style="text-align: center;">961753490000</td> <td>RISER CLAMP ASSY-OD-88.9-VAR03 ARM LENGTH-400</td> <td style="text-align: center;">46</td> <td style="text-align: center;">2-80-999-99258 Var 03</td> </tr> <tr> <td style="text-align: center;">9</td> <td style="text-align: center;">961753510000</td> <td>RISER CLAMP ASSY-OD-114.3-VAR05 ARM LENGTH-400</td> <td style="text-align: center;">52</td> <td style="text-align: center;">2-80-999-99258 Var 05</td> </tr> </tbody> </table> <p><b>For details of part drawings refer Annexure-A enclosed.</b></p>					Item No	Material Code	Item Description	Qty in Nos	Assembly drawing Ref & Variant	1	948219020000	HOR CLAMP ASSY CS OD 88.9-VAR02	595	2-80-999-99251 Var 02	2	948219050000	HOR CLAMP ASSY CS OD 168.3-VAR05	291	2-80-999-99251 Var 05	3	948219060000	HOR CLAMP ASSY CS OD 219.1-VAR06	610	2-80-999-99251 Var 06	4	948219080000	HOR CLAMP ASSY CS OD 273-VAR09	336	2-80-999-99251 Var 09	5	948219110000	HOR CLAMP ASSY CS OD 323.9-VAR12	86	2-80-999-99251 Var 12	6	948219130000	HOR CLAMP ASSY CS OD 355.6-VAR15	129	2-80-999-99251 Var 15	7	948219150000	HOR CLAMP ASSY CS OD 406.4-VAR18	63	2-80-999-99251 Var 18	8	961753490000	RISER CLAMP ASSY-OD-88.9-VAR03 ARM LENGTH-400	46	2-80-999-99258 Var 03	9	961753510000	RISER CLAMP ASSY-OD-114.3-VAR05 ARM LENGTH-400	52	2-80-999-99258 Var 05
Item No	Material Code	Item Description	Qty in Nos	Assembly drawing Ref & Variant																																																			
1	948219020000	HOR CLAMP ASSY CS OD 88.9-VAR02	595	2-80-999-99251 Var 02																																																			
2	948219050000	HOR CLAMP ASSY CS OD 168.3-VAR05	291	2-80-999-99251 Var 05																																																			
3	948219060000	HOR CLAMP ASSY CS OD 219.1-VAR06	610	2-80-999-99251 Var 06																																																			
4	948219080000	HOR CLAMP ASSY CS OD 273-VAR09	336	2-80-999-99251 Var 09																																																			
5	948219110000	HOR CLAMP ASSY CS OD 323.9-VAR12	86	2-80-999-99251 Var 12																																																			
6	948219130000	HOR CLAMP ASSY CS OD 355.6-VAR15	129	2-80-999-99251 Var 15																																																			
7	948219150000	HOR CLAMP ASSY CS OD 406.4-VAR18	63	2-80-999-99251 Var 18																																																			
8	961753490000	RISER CLAMP ASSY-OD-88.9-VAR03 ARM LENGTH-400	46	2-80-999-99258 Var 03																																																			
9	961753510000	RISER CLAMP ASSY-OD-114.3-VAR05 ARM LENGTH-400	52	2-80-999-99258 Var 05																																																			
2	<p><b>TECHNICAL REQUIREMENT-</b></p> <ol style="list-style-type: none"> <li>1. Supply of Horizontal pipe clamp assembly and Riser pipe clamp assembly as per BHEL drawings, QCP 06 &amp; QPG 45.</li> <li>2. Pipe clamps shall be manufactured from FLATS or from PLATES sheared along the grains and the edges dressed off sharp corners</li> <li>3. Substitution of plate materials IS 2002 Class 3 in place of SA 515 Gr 70 (C) is acceptable. <b>IS 2062 structural plates are not acceptable.</b></li> <li>4. All holes shall be match drilled by assembling the half clamps.</li> <li>5. Clamps shall be supplied in assembled condition along with fasteners etc as shown in the assembly drawings 2-80-999-99251 &amp; 2-80-999-99258.</li> <li>6. Marking and identification shall be as per Cl. 8 of QCP 06 Rev 07.</li> <li>7. Surface preparation, painting and colour coding shall be as per Cl. 9 of QCP 06 Rev 07.</li> <li>8. Items should be neatly packed and put in a separate wooden box indicating marking of the Material code, Item description, quantity and box no. in the Packing list.</li> </ol>																																																						
3	<p><b>EXPERIENCE CRITERIA:</b></p> <p>The Bidder shall be a manufacturer. Bidder (manufacturer) should have manufactured and supplied any grade of similar clamp assemblies. Such supply experience shall not be prior to 4 years from the date of bid opening.</p> <p>For fulfilling the experience criteria any one of the following documents may be considered as valid proof for meeting the experience criteria:</p> <ol style="list-style-type: none"> <li>a. Purchase Order copy along with Invoice(s) with self-certification by the bidder that supplies against the invoices have been executed.</li> <li>b. Execution certificate by client with order value.</li> <li>c. Any other document in support of order execution like Third Party Inspection release note etc.,</li> </ol> <p><b>For MSE vendors, experience is relaxed by 1 year and for Startups experience is relaxed by 2 years i.e., supply experience shall not be prior to 5 years for MSE and 2 years for Startups from the date of bid opening. Relaxation is subject to vendors meeting technical and quality criteria.</b></p>																																																						

## ADDITIONAL TERMS & CONDITIONS FOR HORIZONTAL AND RISER CLAMP ASSEMBLIES

SI No	BHEL requirement
4	<p><b>BIDDER TURN OVER CRITERIA:</b> The annual financial turnover of the bidder (manufacturer) during any one of the last three years, ending on 31st March of the previous financial year, should be as indicated in the bid document. Documentary evidence in the form of certified Audited Balance Sheets of relevant financial year from the bidder or a certificate from the Chartered Accountant / Cost Accountant indicating the turnover details for the relevant period shall be uploaded with the bid. In case the date of constitution / incorporation of the bidder is less than 3 year old, the average turnover in respect of the completed financial years after the date of constitution shall be taken into account for this criteria.</p> <p><b>For Startups and MSE vendors, financial turnover is relaxed by 50%. Relaxation is subject to vendors meeting technical and quality criteria.</b> Vendors proposing to avail relaxation in Experience &amp; Turnover criteria as above need to submit the following document proof along with other bid documents a) Startups - Certificate of Recognition by Department of Industrial Policy &amp; Promotion b) MSE - Udyam Registration certificate.</p>
5	<p><b>DELIVERY PERIOD-</b> <b>90 days</b> from the date of Purchase order.</p>
6	<p><b>LIQUIDATED DAMAGES-</b> If the Seller/Service Provider fails to deliver any or all of the Goods/Services within the original/re-fixed delivery period(s) specified in the contract, the Buyer will be entitled to deduct/recover the Liquidated Damages for the delay, unless covered under Force Majeure conditions aforesaid, @ 0.5% of the contract value of delayed quantity per week or part of the week of delayed period as pre-estimated damages not exceeding 10% of the contract value of delayed quantity without any controversy/dispute of any sort whatsoever.</p>
7	<p><b>DELIVERY TERM-</b> 'FOR' Ward 55 BHEL Trichy Stores (all incl of P&amp;F, F&amp;I, testing, inspection charges etc).</p>
8	<p><b>EVALUATION &amp; ORDERING-</b></p> <ol style="list-style-type: none"> <li>1. Evaluation of bids and ranking of bidders shall be done on package basis. Bidder shall quote for all items of a package mandatorily.</li> <li>2. Quoted rates shall be <b>inclusive of GST.</b></li> </ol> <p>Minimum Order Quantity (MOQ) / Minimum Order Value (MOV) condition will not be accepted. Bids of such bidders (if any) insisting for MOQ / MOV will be rejected.</p>
9	<p><b>GUARANTEE-</b> Bidders shall guarantee the supplies for a period of 24 months from the date of dispatch of materials or 18 months from the date of their commissioning whichever is earlier.</p> <p>To this effect a Guarantee certificate should be sent along with the dispatch documents in the event an order is placed on you.</p> <p>Material shall be guaranteed against manufacturing defects or faulty workmanship for a period of 24 months from the date of receipt of pipes with coating at project site. Any defect noticed during this period shall be repaired/replaced free of cost, to the satisfaction of BHEL and the End User. No deviation in this regard shall be accepted.</p>

## **ADDITIONAL TERMS & CONDITIONS FOR HORIZONTAL AND RISER CLAMP ASSEMBLIES**

<b>SI No</b>	<b>BHEL requirement</b>
10	<p><b>INSPECTION-</b> Inspection shall be as per BHEL drawings, QCP 06 &amp; QPG 45.</p> <p>Inspection will be done by <b>BHEL / Authorized agency (Bureau Veritas India Pvt Ltd)</b>. Inspection charges of BHEL / Their representative are to BHEL A/c. Any other testing charges should be included in the quoted prices.</p> <ul style="list-style-type: none"><li>➤ All facilities, equipment and instruments required for inspection shall be provided by the contractor free of cost. BHEL's Representatives will have free access to contractor's works during the currency of the contract.</li><li>➤ BHEL shall have general supervision and direction over the work. BHEL has the authority to stop the work, whenever such stoppage may be necessary to ensure the proper execution of the contract. BHEL shall also have the authority to reject all the work which does not conform to the specification.</li></ul> <p>BHEL if required may test the finished sample per lot/size at NABL approved Lab at the bidder's cost.</p>
11	<p><b>PAYMENT DOCUMENTS-</b> Payment shall be made against submission of the following documents-</p> <ul style="list-style-type: none"><li>a) Commercial Invoice in triplicate</li><li>b) Delivery Challan in triplicate whichever is applicable</li><li>c) Guarantee certificate</li><li>d) Lorry Way Bill (Original + Two copies)</li><li>e) Quality documents (as per approved QP/PO)</li></ul> <p>If one original certificate / LR is applicable for more than one invoice quantity / invoice, Xerox copy is acceptable with original correlation details on the Xerox copy with attestation by suppliers Quality in charge.</p>

FIRST ANGLE PROJECTION (ALL DIMENSIONS IN MILLIMETERS)

15766666-08-2

ON DRAWING

ASSY VAR.NO	PIPE SIZE	ITEM NO:01 PIPE CLAMP		ITEM NO:02 LOAD PIN		ITEM NO:03 STUD		ITEM NO:04 NUT		ITEM NO:05 STUD WASHER		ITEM NO:06 LOAD PIN WASHER		ITEM NO:07 SPLIT PIN		ITEM NO:08 SPACER RING		TOTAL WT(Kg)	BIN.CODE	REMARKS							
		DRAWING NO	QTY	DRAWING NO	QTY	DRAWING NO	QTY	DRAWING NO	QTY	DRAWING NO	QTY	DRAWING NO	QTY	DRAWING NO	QTY	DRAWING NO	QTY										
01	73.0	2.80.999.99250	01	2	4.80.999.99307	08	1	4.80.999.99308	05	2	413.19.12000	-	8	414.08.12000	-	4	414.08.16000	-	2	417.04.04025	-	2	4.80.999.99323	01	1	2.285	
02	88.9		02			08			05															01		2.525	
03	114.3		03			08			05															01		2.765	
04	168.3		04			08			05															01		2.865	
05	168.3		05			09			05				414.08.24000	-		417.04.06045	-						01		6.201		
06	219.1		06			08			05				414.08.16000	-		417.04.04025	-						01		5.805		
07	219.1		07			10			01		413.19.20000	-		414.08.20000	-		414.08.27000	-					07		13.083		
08	273.0		08			08			05		413.19.12000	-		414.08.12000	-		414.08.16000	-					01		3.825		
09	273.0		09			09			05		413.19.12000	-		414.08.12000	-		414.08.24000	-					01		10.901		
10	273.0		10			11			01		413.19.20000	-		414.08.20000	-		414.08.33000	-					07		17.381		
11	323.9		11			08			05		413.19.12000	-		414.08.12000	-		414.08.16000	-					01		7.425		
12	323.9		12			10			07		413.19.20000	-		414.08.20000	-		414.08.27000	-					07		18.931		
13	323.9		13			12			02		413.19.24000	-		414.08.24000	-		414.08.39000	-					09		30.347		
14	355.6		14			08			05		413.19.12000	-		414.08.12000	-		414.08.16000	-					01		8.005		
15	355.6		15			10			07		413.19.20000	-		414.08.20000	-		414.08.27000	-					07		20.231		
16	355.6		16			12			02		413.19.24000	-		414.08.24000	-		414.08.39000	-					09		33.607		
17	406.4		17			08			05		413.19.12000	-		414.08.12000	-		414.08.16000	-					01		8.765		
18	406.4		18			10			07		413.19.20000	-		414.08.20000	-		414.08.27000	-					07		23.391		
19	406.4		19			12			02		413.19.24000	-		414.08.24000	-		414.08.39000	-					09		39.217		
20	457.0		20			09			05		413.19.12000	-		414.08.12000	-		414.08.24000	-					02		15.523		
21	457.0		21			11			07		413.19.20000	-		414.08.20000	-		414.08.33000	-					07		30.409		
22	457.0		22			12			06	4	413.19.16000	-	16	414.08.16000	-	8	414.08.39000	-					06	2	42.744		
23	508.0		23			09			05	2	413.19.12000	-	8	414.08.12000	-	4	414.08.24000	-					03	1	16.886		
24	508.0		24			11			07		413.19.20000	-		414.08.20000	-		414.08.33000	-					07		32.889		
25	508.0		25			12			02		413.19.24000	-		414.08.24000	-		414.08.39000	-					09		47.947		
26	559.0		26			09			05		413.19.12000	-		414.08.12000	-		414.08.24000	-					04		18.671		
27	559.0		27			11			07		413.19.20000	-		414.08.20000	-		414.08.33000	-					07		43.009		
28	559.0		28			12			02		413.19.24000	-		414.08.24000	-		414.08.39000	-					09		55.087		
29	610.0		29			09			05		413.19.12000	-		414.08.12000	-		414.08.24000	-					05		24.177		
30	610.0		30			11			07		413.19.20000	-		414.08.20000	-		414.08.33000	-					08		44.793		
31	610.0		31			12			02		413.19.24000	-		414.08.24000	-		414.08.39000	-					09		65.107		

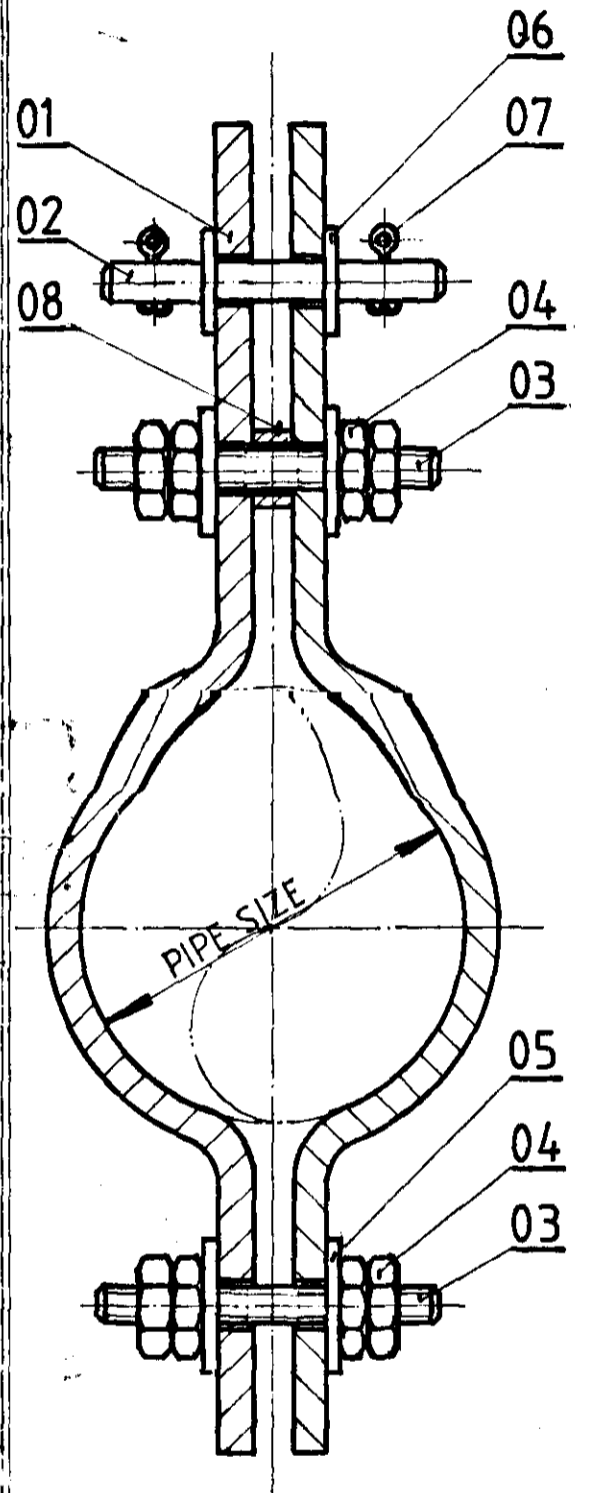

NOTE  
 01. REFER DRAWING NO: 2.80.999.99250. FOR NOTES.  
 02. REFER DRAWING NO: 2.80.999.99252. FOR CLAMP SELECTION.

2-80-999-99251

TYPE OF PRODUCT OR NAME OF CUSTOMER / PROJECT		STANDARD			
BHARAT HEAVY ELECTRICALS LTD., PIPING CENTRE, MADRAS		DRN	NAME R. SRINIVASAN	DATE	No. OF VAR
		CHD	R. ANANTH		
		APPD	S. JAYAKUMAR	5/5/70	
REV	DATE	ALTERED	R. SRINIVASAN	DEPT.	GRADE OF UN TOL DIM
01	19.04.91	CHECKED			C/M/F
FOR VAR. NOS. 07, 10, 13, 16, 19, 22, 25, 28 & 31. TOTAL ASSY. WT. ALTD		SCALE	NTS	WEIGHT (KG)	REFER TABLE
TITLE PIPE CLAMP ASSY (CS)		CARD CODE	DRAWING No.	REF TO ASSY/ GLO DRG	ITEM No.
		001	2.80.999.99251		01

03-22

CAUTION THE INFORMATION ON THIS DOCUMENT IS THE PROPERTY OF BHARAT HEAVY ELECTRICALS LTD. IT MUST NOT BE USED DIRECTLY OR INDIRECTLY IN ANY WAY DETRIMENTAL TO THE INTEREST OF THE COMPANY.

8

7

6

5

4

05-228/C

05266-666-08-2

DRAWING NO.

VAR NO	PIPE SIZE O.D	RAW MATL SIZE T x W x DL	L1	L2	L3	L4	∅ d1	∅ d2	F	H	R1	R2	θ°			TYPE	MATL CODE	WT (Kg)	REMARKS
01	73.0	8 x 50 x 265	24	90	227	18	15	18	10	—	38.2	16	57			A	15.942.222	0.83	
02	88.9	8 x 50 x 302	24	101	257	18	15	18	10	—	46.2	16	61			A	15.942.222	0.95	
03	114.3	8 x 50 x 339	24	97	282	18	15	18	10	—	59.2	16	66			A	15.942.222	1.07	
04	168.3	8 x 40 x 447	24	117	361	18	15	18	10	—	86.7	16	72			A	15.942.222	1.12	
05	168.3	12 x 60 x 463	36	121	381	18	15	26	10	—	86.7	24	68			A	15.942.110	2.62	
06	219.1	12 x 50 x 550	24	126	441	18	15	18	10	—	112.5	24	72			A	15.942.110	2.59	
07	219.1	16 x 75 x 586	42	131	473	30	23	30	12.5	—	112.5	32	68			A	15.942.112	5.52	
08	273.0	8 x 40 x 640	24	142	496	18	15	18	10	—	140	16	78			A	15.942.222	1.60	
09	273.0	16 x 60 x 659	36	136	527	18	15	26	10	—	140	32	72			A	15.942.112	4.97	
10	273.0	16 x 85 x 688	51	146	547	30	23	36	12.5	—	140	32	71			A	15.942.112	7.35	
11	323.9	12 x 50 x 723	24	131	557	18	15	18	10	—	165.8	24	77			A	15.942.110	3.40	
12	323.9	20 x 70 x 763	42	126	599	30	23	30	12.5	—	165.8	40	71			A	15.942.113	8.38	
13	323.9	20 x 105 x 788	62	143	621	36	27	41	15	—	165.8	40	71			A	15.942.113	13.00	
14	355.6	12 x 50 x 783	24	139	598	18	15	18	10	—	182	24	78			A	15.942.110	3.69	
15	355.6	20 x 70 x 822	42	134	641	30	23	30	12.5	—	182	40	73			A	15.942.113	9.03	
16	355.6	20 x 110 x 847	62	151	663	36	27	41	15	—	182	40	72			A	15.942.113	14.63	
17	406.4	12 x 50 x 863	24	138	650	18	15	18	10	—	207.8	24	79			A	15.942.110	4.07	
18	406.4	20 x 75 x 901	42	132	693	30	23	30	12.5	—	207.8	40	74			A	15.942.113	10.61	
19	406.4	20 x 120 x 926	62	149	715	36	27	41	15	—	207.8	40	74			A	15.942.113	17.45	
20	457	16 x 60 x 967	36	149	733	18	15	26	10.5	—	233.6	32	78			A	15.942.112	7.28	
21	457	25 x 70 x 1005	51	138	775	30	23	36	12.5	—	233.6	50	73			A	15.942.114	13.80	
22	457	20 x 125 x 997	62	164	771	24	19	41	15	70	233.6	40	75			B	15.942.113	19.56	
23	508	16 x 60 x 1056	36	158	795	18	15	26	11	—	259.5	32	79			A	15.942.112	7.96	
24	508	25 x 70 x 1095	51	146	837	30	23	36	12.5	—	259.5	50	75			A	15.942.114	15.04	
25	508	25 x 100 x 1111	62	154	850	36	27	41	15	—	259.5	50	74			A	15.942.114	21.80	
26	559	16 x 60 x 1175	36	196	885	18	15	26	12	—	285.5	32	80			A	15.942.112	8.85	
27	559	30 x 70 x 1219	51	172	939	30	23	36	12.5	—	285.5	60	74			A	15.942.199	20.10	
28	559	25 x 105 x 1231	62	192	942	36	27	41	15	—	285.5	50	76			A	15.942.114	25.37	
29	610	20 x 60 x 1231	36	160	921	18	15	26	13	—	311.4	40	79			A	15.942.113	11.60	
30	610	30 x 70 x 1273	51	146	967	30	23	36	13	—	311.4	60	75			A	15.942.199	20.99	
31	610	30 x 100 x 1290	62	154	981	36	27	41	15	—	311.4	60	75			A	15.942.199	30.38	

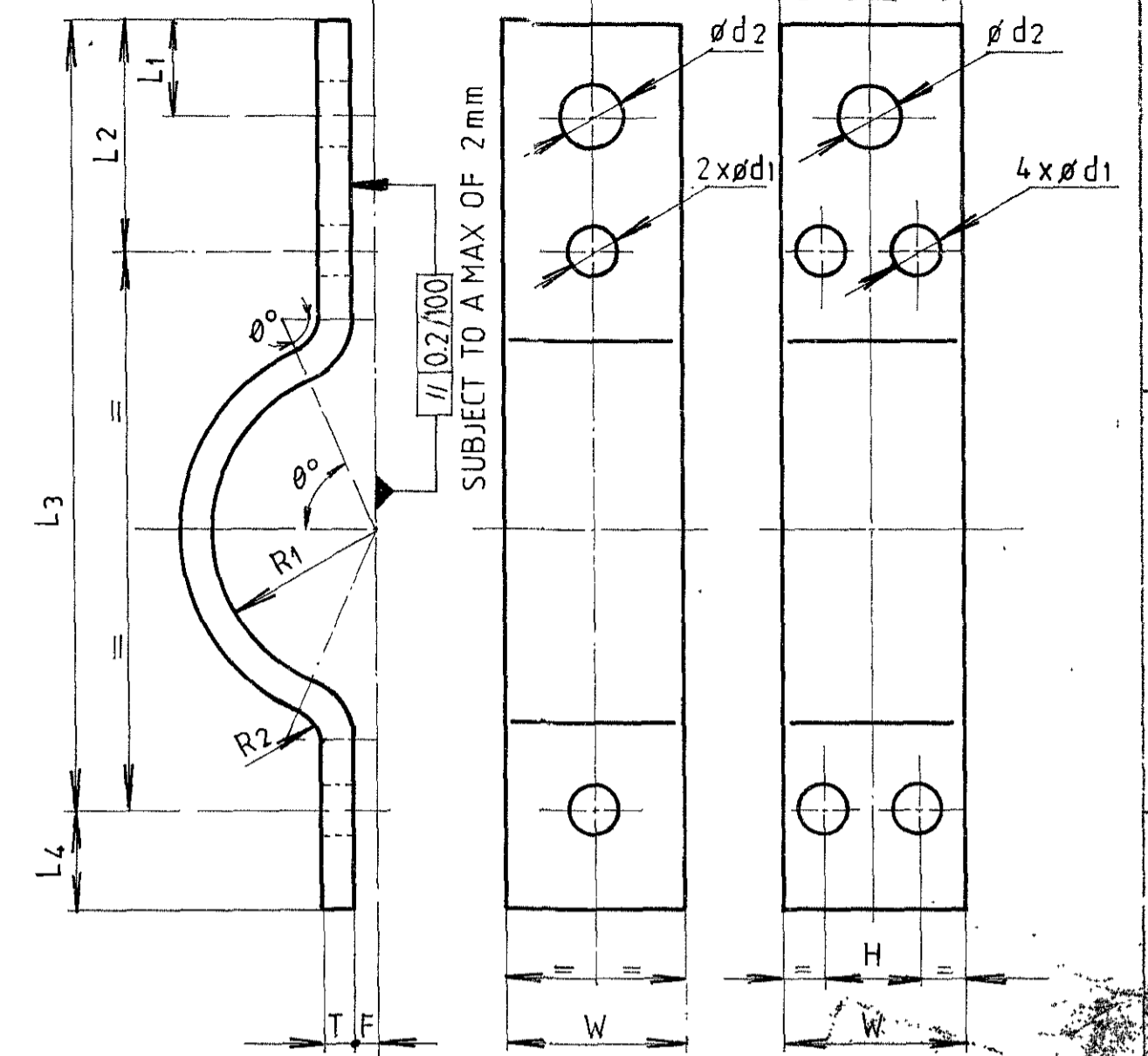

- NOTE:**
- PIPE CLAMPS SHALL BE MANUFACTURED FROM FLATS OR FROM PLATES SHEARED ALONG THE GRAINS AND THE EDGES DRESSED OFF SHARP CORNERS.
  - SUBSTITUTION OF PLATE MATERIALS IS-2002 CLASS.3 IN PLACE OF GR.70 (C) IS ACCEPTABLE
  - ALL HOLES TO BE MATCH DRILLED BY ASSEMBLING THE HALF CLAMPS.
  - MANUFACTURE AND INSPECTION SHALL BE AS PER QCP NO. 06 OF PIPING CENTRE.
  - DIMENSIONS W, H, L1, L2, L3 & L4 SHALL BE MAINTAINED WITH TOLERANCE OF ±1mm FROM THE EDGE.
  - REFER DRAWING NO: 2.80.999.99251 FOR BOM DETAILS & DRAWING NO: 2.80.999.99252 FOR CLAMP SELECTION.
  - CLAMPS SHALL BE SUPPLIED IN ASSEMBLED CONDITION ALONG WITH FASTENERS ETC AS SHOWN IN DRAWING NO: 2.80.999.99252.
  - BIN CODES SHALL BE PUNCHED ON THE CLAMP ASSY AFTER MANUFACTURE.

TYPE OF PRODUCT OR NAME OF CUSTOMER PROJECT		STANDARD MATERIAL SA.515 GR.70 (C)	
BHARAT HEAVY ELECTRICALS LTD., PIPING CENTRE, MADRAS		DRN R.SRINIVASAN CHD R.ANANTH APPD S.JAYAKUMAR	SIGN DATE 5/5/60
DEPT. CODE	GRADE OF UN TOL. DIM C/M/F	SCALE NTS	WEIGHT (Kg) REFER TABLE
TITLE PIPE CLAMP (C.S)		CARD CODE U 01	DRAWING No 2.80.999.99250. 02

REV DATE ALTD: 01 19 04 91 ALTERED R SRINIVASAN.  
 CHECKED  
 QCP NO. ALTERED IN ZONE FOR VAR.NOS.13,16,19,22,25,28, AND 31 HOLE ∅d2 ALTD FROM 43 To 41 mm  
 NOTE-4.

05-228/C  
CAUTION THE INFORMATION ON THIS DOCUMENT IS THE PROPERTY OF BHARAT HEAVY ELECTRICALS LTD. IT MUST NOT BE USED DIRECTLY OR INDIRECTLY IN ANY WAY DETRIMENTAL TO THE INTEREST OF THE COMPANY.

FIRST ANGLE PROJECTION (ALL DIMENSIONS IN MILLIMETRES)

VAR. NO	TYPE	PIPE SIZE DIA. m.m	L1		L2		L3	C	ød1	ød2	F	R1	R2	θ°	T x W	DEV. LENGTH		MATL. CODE	WEIGHT		REMARKS	VAR NO
			MIN	MAX	MIN	MAX										MIN	MAX		MIN	INCREMENT IN Kg/100mm		
01.	A	73.0	400	650	25	125	250	—	30	15	18	10			12 x 110	467	717	15.942.110	4.84	1.036		01
02.	A	73.0	400	650	37	120	245	—	30	15	26	10			16 x 140	490	740	15.942.112	8.62	1.758		02
03.	A	88.9	400	650	25	115	240	—	30	15	18	10			12 x 110	474	724	15.942.110	4.91	1.036		03
04.	A	88.9	400	650	37	109	234	—	30	15	26	10			16 x 135	497	747	15.942.112	8.43	1.696		04
05.	A	114.3	400	800	25	100	300	—	30	15	18	10			12 x 120	486	886	15.942.110	5.50	1.130		05
06.	A	114.3	400	800	37	87	287	—	30	15	26	10			20 x 110	506	906	15.942.113	8.74	1.727		06
07.	A	168.3	550	900	25	145	320	—	30	15	18	10			12 x 135	664	1014	15.942.110	8.44	1.272		07
08.	B	168.3	550	900	37	84	259	46	30	15	26	10			20 x 115	681	1031	15.942.113	12.30	1.806		08
09.	B	168.3	550	900	43	75	250	46	30	15	30	10			25 x 120	690	1040	15.942.114	16.25	2.355		09
10.	A	219.1	650	1000	25	167	342	—	30	15	18	10			12 x 145	791	1141	15.942.110	10.80	1.366		10
11.	A	219.1	650	1000	37	151	326	—	30	15	26	10			20 x 130	807	1157	15.942.113	16.47	2.041		11
12.	B	219.1	650	1000	43	95	270	46	30	15	30	10			25 x 130	815	1165	15.942.114	20.79	2.551		12
13.	A	273.0	750	1100	25	180	355	—	30	15	18	10			16 x 110	915	1265	15.942.112	12.64	1.382		13
14.	A	273.0	750	1100	37	171	346	—	30	15	26	10			20 x 140	935	1285	15.942.113	20.55	2.198		14
15.	B	273.0	750	1100	43	105	280	46	30	15	30	10			30 x 110	938	1288	15.942.199	24.30	2.591		15
16.	B	273.0	750	1100	52	81	256	52	35	19	36	15			40 x 135	943	1293	15.942.117	39.97	4.239		16
17.	A	323.9	900	1200	25	228	378	—	30	15	18	10			16 x 110	1093	1393	15.942.112	15.10	1.382		17
18.	B	323.9	900	1200	37	162	312	46	30	15	26	10			25 x 110	1106	1406	15.942.114	23.88	2.159		18
19.	B	323.9	900	1200	43	152	302	46	30	15	30	10			30 x 110	1114	1414	15.942.199	28.86	2.591		19
20.	B	323.9	900	1200	52	116	266	58	40	23	36	13			40 x 145	1120	1420	15.942.117	50.99	4.553		20
21.	A	355.6	900	1250	25	211	386	—	30	15	18	10			16 x 110	1110	1460	15.942.112	15.34	1.382		21
22.	B	355.6	900	1250	37	145	320	46	30	15	26	10			25 x 110	1123	1473	15.942.114	24.24	2.159		22
23.	B	355.6	900	1250	43	135	310	46	30	15	30	10			30 x 115	1130	1480	15.942.199	30.60	2.708		23
24.	B	355.6	900	1250	52	98	273	58	40	23	36	13			40 x 150	1135	1485	15.942.117	53.46	4.710		24
25.	A	406.4	950	1400	25	209	434	—	30	15	18	10			16 x 110	1189	1639	15.942.112	16.43	1.382		25
26.	B	406.4	950	1400	37	143	368	46	30	15	26	10			25 x 115	1201	1651	15.942.114	27.11	2.257		26
27.	B	406.4	950	1400	43	132	357	46	30	15	30	10			30 x 120	1207	1657	15.942.199	34.11	2.826		27
28.	B	406.4	950	1400	52	95	320	58	40	23	36	13			40 x 165	1211	1661	15.942.117	62.74	5.181		28
29.	A	457.0	1000	1500	25	209	459	—	30	15	18	13			16 x 115	1262	1762	15.942.112	18.23	1.444		29
30.	B	457.0	1000	1500	37	142	392	46	30	15	26	13			25 x 120	1274	1774	15.942.114	30.00	2.355		30
31.	B	457.0	1000	1500	43	122	372	52	35	19	30	15			30 x 130	1277	1777	15.942.199	39.10	3.062		31
32.	B	457.0	1000	1500	52	92	342	58	40	23	36	13			40 x 175	1287	1787	15.942.117	70.72	5.495		32
33.	A	508.0	1050	1500	25	207	432	—	30	15	18	13			16 x 110	1341	1791	15.942.112	18.53	1.382		33
34.	B	508.0	1050	1500	37	140	365	46	30	15	26	13			25 x 115	1352	1802	15.942.114	30.51	2.257		34
35.	B	508.0	1050	1500	43	120	345	52	35	19	30	15			30 x 125	1354	1804	15.942.199	39.86	2.944		35
36.	B	508.0	1050	1500	52	89	314	58	40	23	36	13			40 x 165	1364	1814	15.942.117	70.67	5.181		36
37.	A	559.0	1150	1550	25	231	431	—	30	15	18	13			16 x 110	1470	1870	15.942.112	20.31	1.382		37
38.	B	559.0	1150	1550	37	163	363	46	30	15	26	13			25 x 115	1480	1880	15.942.114	33.40	2.257		38
39.	B	559.0	1150	1550	43	143	343	52	35	19	30	15			30 x 125	1482	1882	15.942.199	43.63	2.944		39
40.	B	559.0	1150	1550	52	102	302	65	50	27	36	15			40 x 170	1488	1888	15.942.117	79.43	5.338		40
41.	A	610.0	1200	1600	25	229	429	—	30	15	18	13			16 x 110	1548	1948	15.942.112	21.39	1.382		41
42.	B	610.0	1200	1600	37	161	361	46	30	15	26	13			25 x 115	1558	1958	15.942.114	35.16	2.257		42
43.	B	610.0	1200	1600	43	141	341	52	35	19	30	15			30 x 125	1560	1960	15.942.199	45.92	2.944		43
44.	B	610.0	1200	1600	52	99	299	65	50	27	36	15			40 x 170	1566	1966	15.942.117	83.59	5.338		44

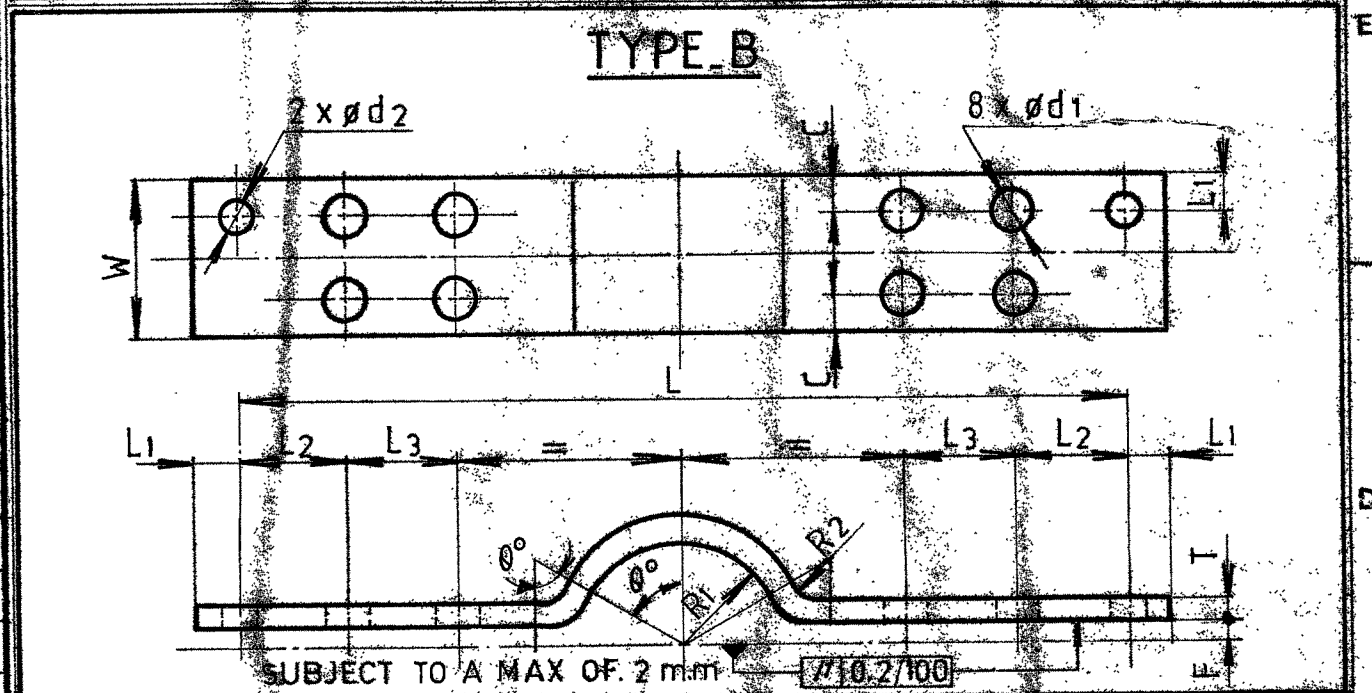
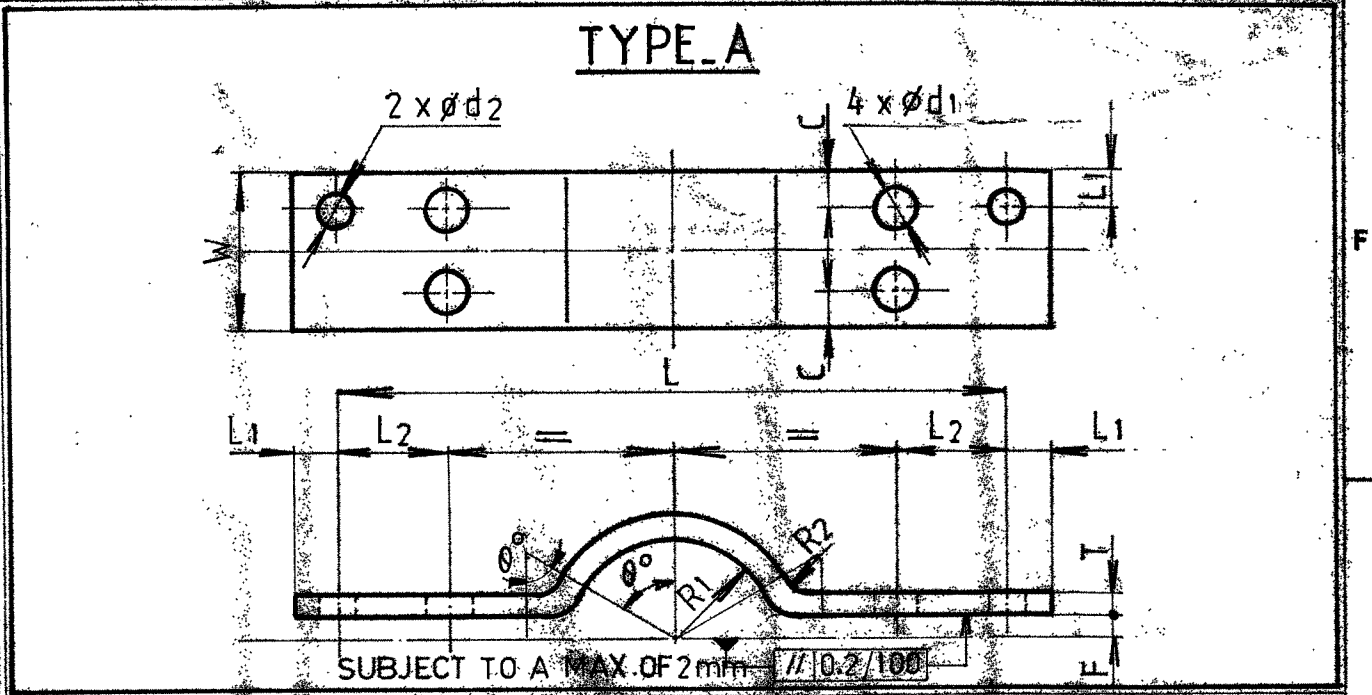

**NOTES:**

- FOR ACTUAL 'L' DIMENSION REFER G.M.S.
- 'L' VALUE SELECTED SHALL BE BETWEEN 'L' MIN. AND 'L' MAX.
- SUBSTITUTION OF PLATE MATERIAL IS: 2002 CLASS 3 IN PLACE OF SA-515 GR 70 (C) IS ACCEPTABLE.
- MANUFACTURE AND INSPECTION SHALL BE AS PER QCP NO. OF PIPING CENTRE.
- ALL HOLES SHALL BE MATCH DRILLED BY ASSEMBLING THE HALF CLAMPS.
- REFER DRAWING NO: 2.80.999.99258 FOR B.O.M. DETAILS & DRAWING NO: 2.80.999.99259 FOR CLAMP SELECTION.
- ACTUAL WEIGHT SHALL BE CALCULATED FROM 'L' ACTUAL (FROM G.M.S.)
- ACTUAL WEIGHT = WEIGHT FOR 'L' MIN +  $\frac{[L' ACTUAL - L' MIN] \times INCREMENT \times WT}{100}$
- ACTUAL DEVELOPED LENGTH = DL FOR 'L' MIN +  $\frac{[L' ACTUAL - L' MIN] \times T}{2}$
- CLAMPS SHALL BE SUPPLIED IN ASSEMBLED CONDITION ALONG WITH FASTENERS ETC AS SHOWN IN DRAWING NO: 2.80.999.99258.
- ACTUAL 'L2' =  $L2 \text{ MIN} + \frac{[L' ACTUAL - L' MIN] \times T}{2}$

TYPE OF PRODUCT OR NAME OF CUSTOMER | PROJECT **STANDARD MATERIAL: SA 515 GR 70 (C)**

DRN	R. SHRINIVASAN	DATE	
CHD	R. ANANTH		
APPD	S. JAYAKUMAR	DATE	3/1/24

DEPT. GRADE OR UN TOL DIM C/M/F SCALE NTS WEIGHT (KG) REFER TABLE

TITLE **RISER CLAMP (CS)** CARD CODE 01 DRAWING No. **2.80.999.99257** REV 02

REV DATE 02/20/10 APPD 3/2/24  
 APPROVED: [Signature]  
 QCP NO. ALTERED IN NOTE 4.

05-228/C

CAUTION: THE INFORMATION ON THIS DOCUMENT IS THE PROPERTY OF BHARAT HEAVY ELECTRICALS LTD. IT MUST NOT BE USED DIRECTLY OR INDIRECTLY IN ANY WAY DETRIMENTAL TO THE INTEREST OF THE COMPANY.

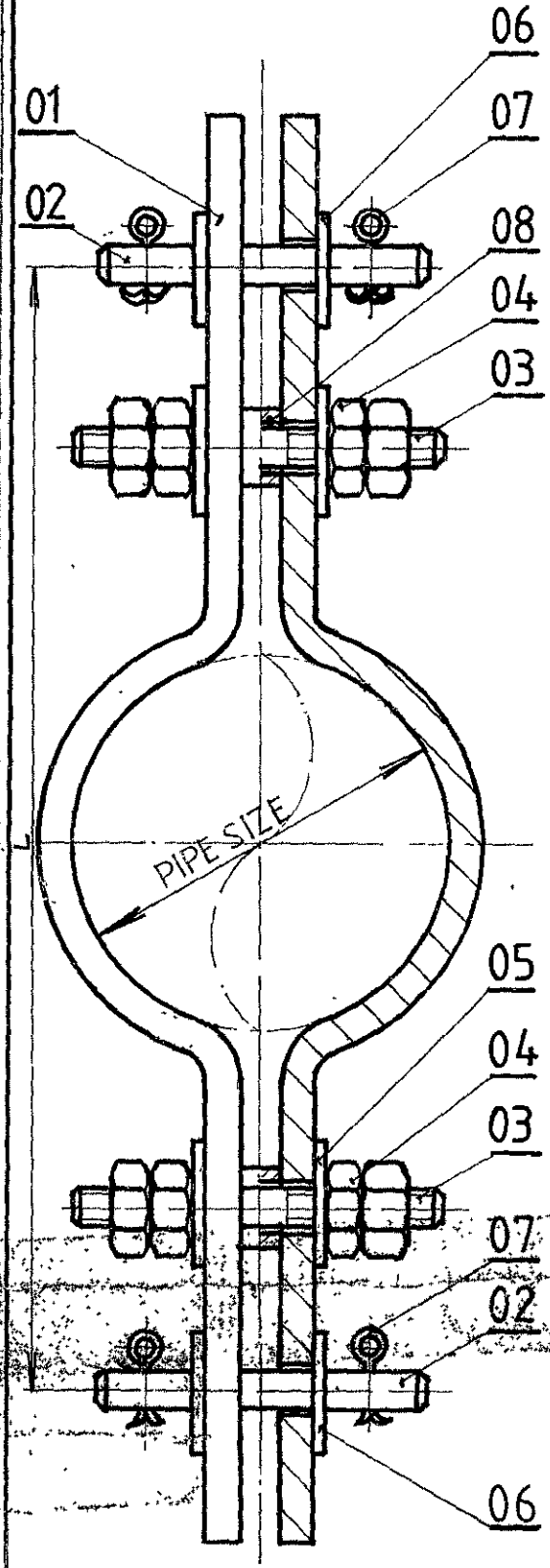

ASSY VAR. NO	PIPE SIZE	ITEM NO:01 RISER CLAMP		ITEM NO:02 LOAD PIN		ITEM NO:03 STUD		ITEM NO:04 NUT		ITEM NO:05 STUD WASHER		ITEM NO:06 LOAD PIN WASHER		ITEM NO:07 SPLIT PIN		ITEM NO:08 SPACER RING		L MIN	ASSY WT. FOR 100mm OF L	INCREMENT WT. Kg PER 100mm OF L	REMARKS									
		DRAWING NO.	VAR. NO.	QTY	DRAWING NO.	VAR. NO.	QTY	DRAWING NO.	VAR. NO.	QTY	DRAWING NO.	VAR. NO.	QTY	DRAWING NO.	VAR. NO.	QTY	DRAWING NO.					VAR. NO.	QTY							
01	73.0	2.80.999.99257	01	2	4.80.999.99307	08	2	4.80.999.99308	05	4	413.19.12000	-	16	414.08.12000	-	8	414.08.16000	-	4	417.04.04025	-	4	4.80.999.99323	01	4	400	11.036	2.072	01	
02	73.0		02		09												414.08.24000	-	4	417.04.06045	-					400	19.268	3.516	02	
03	88.9		03		08												414.08.16000	-		417.04.04025	-					400	11.176	2.072	03	
04	88.9		04		09												414.08.24000	-		417.04.06045	-					400	18.888	3.392	04	
05	114.3		05		08												414.08.16000	-		417.04.04025	-					400	12.356	2.260	05	
06	114.3		06		09												414.08.24000	-		417.04.06045	-					400	19.508	3.454	06	
07	168.3		07		08												414.08.16000	-		417.04.04025	-					550	18.236	2.544	07	
08	168.3		08		09				8								414.08.24000	-		417.04.06045	-				8	550	27.608	3.612	08	
09	168.3		09		10				8								414.08.27000	-		417.04.06045	-				8	550	35.860	4.710	09	
10	219.1		10		08				4								414.08.16000	-		417.04.04025	-				4	650	22.956	2.732	10	
11	219.1		11		09				4								414.08.24000	-		417.04.06045	-				4	650	34.968	4.082	11	
12	219.1		12		10				8								414.08.27000	-		417.04.06045	-				8	650	44.940	5.102	12	
13	273.0		13		08				4								414.08.16000	-		417.04.04025	-				4	750	26.636	2.764	13	
14	273.0		14		09				4								414.08.24000	-		417.04.06045	-				4	750	43.128	4.396	14	
15	273.0		15		14				8								414.08.27000	-		417.04.06045	-				8	750	52.200	5.182	15	
16	273.0		16		15			09	8	413.19.16000	-	32	414.08.16000	-	16	414.08.33000	-			417.04.08056	-		06	8	750	87.408	8.478	16		
17	323.9		17		08			05	4	413.19.12000	-	16	414.08.12000	-	8	414.08.16000	-			417.04.04025	-		01	4	900	31.556	2.764	17		
18	323.9		18		09				8								414.08.24000	-		417.04.06045	-				8	900	50.768	4.318	18	
19	323.9		19		14												414.08.27000	-		417.04.06045	-				8	900	61.320	5.182	19	
20	323.9		20		15			08		413.19.20000	-	32	414.08.20000	-	16	414.08.33000	-			417.04.08056	-		08	8	900	111.744	9.106	20		
21	355.6		21		08			05	4	413.19.12000	-	16	414.08.12000	-	8	414.08.16000	-			417.04.04025	-		01	4	900	32.036	2.764	21		
22	355.6		22		09				8								414.08.24000	-		417.04.06045	-				01	8	900	51.488	4.318	22
23	355.6		23		14												414.08.27000	-		417.04.06045	-				01	8	900	61.320	5.182	23
24	355.6		24		15			08		413.19.20000	-	32	414.08.20000	-	16	414.08.33000	-			417.04.08056	-		08	8	900	111.744	9.106	24		
25	406.4		25		08			05	4	413.19.12000	-	16	414.08.12000	-	8	414.08.16000	-			417.04.04025	-		01	4	950	34.216	2.764	25		
26	406.4		26		09				8								414.08.24000	-		417.04.06045	-				01	8	950	57.228	4.514	26
27	406.4		27		14												414.08.27000	-		417.04.06045	-				01	8	950	71.820	5.652	27
28	406.4		28		15			08		413.19.20000	-	32	414.08.20000	-	16	414.08.33000	-			417.04.08056	-		08	8	950	135.244	10.362	28		
29	457.0		29		08			05	4	413.19.12000	-	16	414.08.12000	-	8	414.08.16000	-			417.04.04025	-		05	4	1000	37.880	2.888	29		
30	457.0		30		09			05	8	413.19.12000	-	32	414.08.12000	-	16	414.08.24000	-			417.04.06045	-		05	8	1000	63.136	4.710	30		
31	457.0		31		14			09		413.19.16000	-	32	414.08.16000	-	16	414.08.27000	-			417.04.06045	-		06	8	1000	84.352	6.124	31		
32	457.0		32		15			08		413.19.20000	-	32	414.08.20000	-	16	414.08.33000	-			417.04.08056	-		08	8	1000	151.204	10.990	32		
33	508.0		33		08			05	4	413.19.12000	-	16	414.08.12000	-	8	414.08.16000	-			417.04.04025	-		05	4	1050	38.780	2.764	33		
34	508.0		34		09			05	8	413.19.12000	-	32	414.08.12000	-	16	414.08.24000	-			417.04.06045	-		05	8	1050	64.156	4.514	34		
35	508.0		35		14			09		413.19.16000	-	32	414.08.16000	-	16	414.08.27000	-			417.04.06045	-		06	8	1050	85.872	5.998	35		
36	508.0		36		15			08		413.19.20000	-	32	414.08.20000	-	16	414.08.33000	-			417.04.08056	-		08	8	1050	151.704	10.362	36		
37	559.0		37		08			05	4	413.19.12000	-	16	414.08.12000	-	8	414.08.16000	-			417.04.04025	-		05	4	1150	42.040	2.764	37		
38	559.0		38		09			05	8	413.19.12000	-	32	414.08.12000	-	16	414.08.24000	-			417.04.06045	-		05	8	1150	69.936	4.514	38		
39	559.0		39		14			09		413.19.16000	-	32	414.08.16000	-	16	414.08.27000	-			417.04.06045	-		06	8	1150	93.412	5.888	39		
40	559.0		40		15			02		413.19.24000	-	32	414.08.24000	-	16	414.08.33000	-			417.04.08056	-		09	8	1150	172.272	10.676	40		
41	610.0		41		08			05	4	413.19.12000	-	16	414.08.12000	-	8	414.08.16000	-			417.04.04025	-		05	4	1200	44.200	2.764	41		
42	610.0		42		09			05	8	413.19.12000	-	32	414.08.12000	-	16	414.08.24000	-			417.04.06045	-		05	8	1200	73.456	4.514	42		
43	610.0		43		14			09		413.19.16000	-	32	414.08.16000	-	16	414.08.27000	-			417.04.06045	-		06	8	1200	97.992	5.888	43		
44	610.0		44		15			02		413.19.24000	-	32	414.08.24000	-	16	414.08.33000	-			417.04.08056	-		09	8	1200	180.592	10.676	44		

NOTE:  
 01. ACTUAL ASSY WEIGHT = ASSY. WEIGHT FOR °L° MIN +  $\left[ \frac{(\text{°L° SELECTED} - \text{°L° MIN})}{100} \right] \times \text{INCREMENT} \times \text{WEIGHT FOR 100mm OF °L°}$   
 02. FOR ACTUAL °L° DIMENSION REFER GMS.

<b>STANDARD</b>		<b>BHARAT HEAVY ELECTRICALS LTD.</b>		DRN	R. SHRINIVASAN	SIGN	[Signature]	DATE		NO. OF	
		<b>PIPING CENTRE, MADRAS</b>		CHD	R. ANANTH.	SIGN	[Signature]			REV	
				APPD	S. JAYAKUMAR.	SIGN	[Signature]			ITEM	
REV	DATE	ALTERED R. SRINIVASAN.		DPT		GRADE OF UN TOL DIM		SCALE	WEIGHT (KG)	REFER TO ASSY/ OLD DRG	ITEM
01	19.04.91	CHECKED [Signature]		CODE		C/M/F		NTS	REFER TABLE		
ZONE		FOR VAR. NOS. 40 & 44		TITLE		RISER CLAMP ASSY. (CS)		CARD	DRAWING NO.	REV	
		ASSY WT. FOR °L° MIN ALTD.						U 01	2.80.999.99258.	01	

FIRST ANGLE PROJECTION (ALL DIMENSIONS IN MILLIMETRES)

REV 01	DATE 4.5.90	ALTERED N.M.NATHAN. CHECKED sd. s.s.	REV 02	DATE 21.6.90	ALTERED R.SRINIVASAN. CHECKED <i>DP</i>	REV 03	DATE 31.8.90	R.SRINIVASAN. <i>DP</i>
VAR NOS.08 TO 12 ADDED.			VAR NO.13 ADDED.			VAR NOS.14 & 15 ADDED FOR VAR NO:12 $\phi$ d MATL.CODE & WEIGHT ALTERED. DRG REDRAWN.		

REV 04	DATE 22.03.91	ALTERED: R.SRINIVASAN CHECKED: <i>DP</i>
VAR. NOS. 08 TO 15 BIN.CODE ADDED.		
REV 05	DATE 23.11.90	ALTERED: <i>Plumbing</i> APPROVED: R. <i>Chandrasekhar</i>
M.CODE CHANGED FOR ALL VARIANTS		

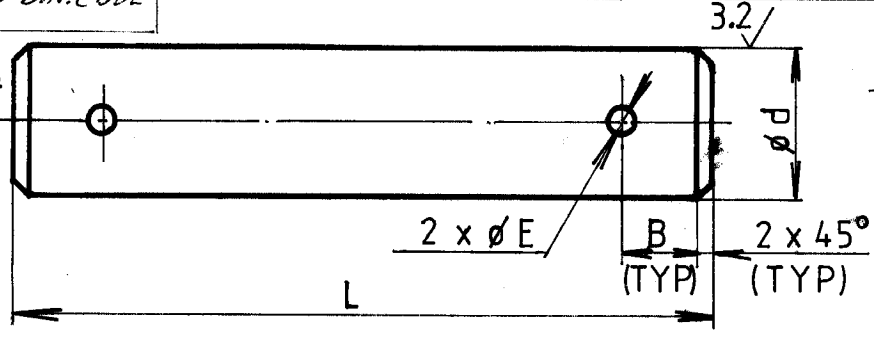

VAR NO	$\phi$ d	$\phi$ E	B	L	MATL.CODE BIN.CODE	MATL SPEC	WT(Kg)	REMARKS
01.	19	7	12	110	15 339 139 0000	SA-105 (C)	0.240	
02.	22	7	12	130	15 339 139 0000		0.380	
03.	24	7	12	150	15 339 139 0000		0.530	
04.	27	7	12	160	15 339 140 0000		0.710	
05.	30	9	15	150	15 339 140 0000		0.830	
06.	33	9	15	150	15 339 280 0000		1.000	
07.	36	9	15	150	15 339 141 0000		1.190	
08.	16	4	12	100	15-339-1390000 94 822 16 10 0000	$\triangle$ 05	0.160	
09.	24	6.3	12	125	15-339-1390000 94 822 24 13 0000		0.440	
10.	28	6.3	12	125	15-339-1400000 94 822 28 13 0000		0.600	$\triangle$ 01
11.	34	8	15	160	15-339-2800000 94 822 34 16 0000		1.140	
12.	39	8	15	165	15-339-1410000 94 822 39 17 0000		1.540	$\triangle$ 03 $\triangle$ 04
13.	46	10	15	165	15-339-1420000 94 822 46 17 0000		2.140	$\triangle$ 02
14.	28	6.3	12	150	15-339-1400000 94 822 28 15 0000		0.720	$\triangle$ 03
15.	34	8	15	180	15-339-2800000 94 822 34 18 0000		1.280	$\triangle$ 03

CAUTION: THIS INFORMATION ON THIS DOCUMENT IS THE PROPERTY OF BHARAT HEAVY ELECTRICALS LTD. IT MUST NOT BE USED DIRECTLY OR INDIRECTLY IN ANY WAY DETRIMENTAL TO THE INTEREST OF THE COMPANY.



**BHARAT HEAVY ELECTRICALS LTD.**  
BOILER PLANT UNIT  
TIRUCHIRAPALLI- 620 014.

DRN.	R.SRINIVASAN	SIGN	<i>R. Srinivasan</i>	DATE	
CHD.	M.M.MANI.	S/D	<i>S/D</i>		
APPD.	S.JAYAKUMAR.	S/D	<i>S/D 26.5.90</i>		

DEPT.	GRADE OF UNTOL DIM C/M/F	SCALE	WEIGHT (Kg)	REF TO ASSY/OLD DRG	ITEM No.
CODE		NTS	REFER TABLE		
TITLE			CARD CODE	DRAWING No.	REV.
LOAD PIN			U01	4.80.999-99307.	05

FIRST ANGLE PROJECTION (ALL DIMENSIONS IN MILLIMETRES)

REV 01	DATE 26.07.91	ALTERED CHECKED: <i>[Signature]</i>	R.SRINIVASAN	REV 02	DATE 29.8.90	ALTERED CHECKED: <i>[Signature]</i>	R.SRINIVASAN	REV 03	DATE 22.03.91	ALTERED CHD: <i>[Signature]</i>	R.SRINIVASAN
NOTE NOS. 01 & 02 ADDED.				NOTE NO.03 ADDED. TOLERANCES ON PARALLALITY & PERPENDICULARITY REMOVED.				VAR. NOS 01, 05, 06, 08 & 09 BIN. CODE ADDED.			

REV NO 04  
DATE 23/11/05  
ALTERED: *[Signature]*  
APPROVED: *[Signature]*  
M-CODE CHANGED FOR ALL VARIANTS

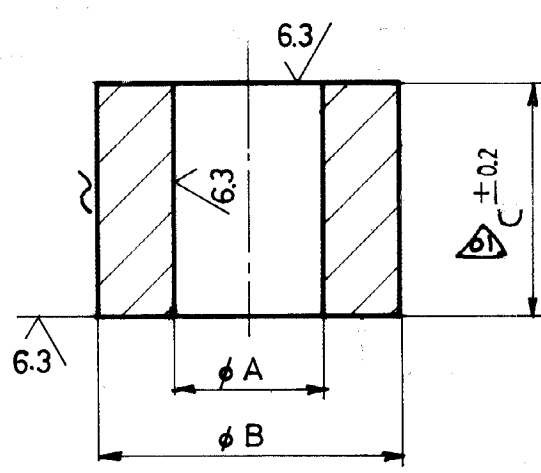

6.3  
✓ / /  
~ / /

CAUTION: THIS INFORMATION IN THIS DOCUMENT IS THE PROPERTY OF BHARAT HEAVY ELECTRICALS LTD. IT MUST NOT BE USED DIRECTLY OR INDIRECTLY IN ANY WAY DETRIMENTAL TO THE INTEREST OF THE COMPANY.

VAR. NO.	$\phi A$	$\phi B$	$C \pm 0.2$	MATL. SPEC.	MATL. CODE		Wt. - kg -	REMARKS
					BIN. CODE			
01	14	25	20	SA105 (C)	15-339-1390000	94 14 25 20 01 00	0.053	$\triangle 03$
02	14	25	21		15-339-1390000		0.055	
03	14	25	22				0.058	
04	14	25	24				0.063	
05	14	25	26		15-339-1390000	94 14 25 26 01 00	0.069	$\triangle 03$
06	18	32	30		15-339-1400000	94 18 32 30 01 00	0.130	$\triangle 03$
07	22	32	25		15-339-1400000		0.083	
08	22	32	26		15-339-1400000	94 22 32 26 01 00	0.087	$\triangle 03$
09	26	36	30		15-339-2800000	94 26 36 30 01 00	0.115	$\triangle 03$

NOTES:  $\triangle 01$   
 01. SUBSTITUTION OF MATERIAL IS: 226/2062 IN PLACE OF SA.105 IS ACCEPTABLE.  
 02. SUITABLE PIPE/TUBE MATERIAL MAY BE USED, IN CONSULTATION WITH ENGINEERING.  
 $\triangle 02$  03. THIS COMPONENT SHALL BE MACHINED TO THE DIMENSIONS ON LATHE IN SINGLE SETTING.

<b>BHARAT HEAVY ELECTRICALS LTD.</b> BOILER PLANT UNIT TIRUCHIRAPALLI-620 014.	DRN.	NAME <i>H. M. Nathan</i>	SIGN <i>[Signature]</i>	DATE 04.05.90
	CHD.	R. ANANTH	<i>[Signature]</i>	
	APPD.	S. Jayakumar	<i>[Signature]</i>	5/5/90

DEPT.	GRADE OF UNTOL DIM C/M/F	SCALE	WEIGHT (Kg)	REF TO ASSY/OLD DRG	ITEM No.
CODE					

TITLE <b>SPACER RING</b>	CARD CODE U 01	DRAWING No. <b>4-80-999-99323</b>	REV. <b>04</b>
-----------------------------	-------------------	--------------------------------------	-------------------



# PLANT STANDARD

HPBP TIRUCHIRAPPALLI

BPS 41319

Rev. No. 03

PAGE 1 OF 2

## NUTS FOR TEMPERATURE USE

(For medium of temperature upto 425 ° C)

### 1.0 SCOPE

Covers the requirements of hexagon nuts for use in medium of temperature upto 425 ° C and in the size range M8 to M45x3.

### 2.0 SPECIFICATION AND REFERENCE STANDARDS

Dimensions and preferred sizes	Fig 1 & Table 1 of this standard	
Tolerance	Product grade	A for nuts with $d \leq M16$ B for nuts with $d > M16$
	Indian Standard	IS 1367 (Part 2)
Thread	Pitch	Table 1 of this standards
	Tolerance	6H
	Indian Standard	IS 4218 (Part 3, 5 & 6)
Material	Steel to ASTM A 194 2H Certified	
Testing	The finished nut shall satisfy the requirements of hardness, proof load and cone proof load, tests as specified in ASTM A194	
General requirements	Nuts shall comply with TDC:5:166 in respect of requirements not covered in this standard, except for cadmium plating	

### 2.1 Referred standards (Only the relevant parts of current versions are applicable)

IS 1367 (Part 2)	Technical supply conditions for threaded steel fasteners
IS 4218 (Part 3,5 & 6)	ISO metric screw threads
TDC:5:166	Carbon steel nuts for OFE & other applications as per A 194 GR 2H/2HM
ASTM A194	Specification for carbon and alloy steel nuts for bolts for high pressure and high temperature service.

### 3.0 DESIGNATION

A Grade 'A' hexagon nut to this standard of thread size M8 shall be designated as :

### 3.1 On Drawings

i) Material Specification column	ASTM A 194 - 2H
ii) Description Column	NUT HEX GR A T425 M8
iii) Drawing Number Column	BPS 41319
iv) Material Code column:	4131900008

COPYRIGHT AND CONFIDENTIAL

The information on this document is the property of BHARAT HEAVY ELECTRICALS LIMITED. It must not be used directly or indirectly in any way detrimental to the interest of the company.

Revisions Brought upto date			Approved STANDARDS SECTION CONTRACT ENGINEERING AND CO-ORDINATION HPBP, TIRUCHIRAPPALLI		
Rev. No. 03	Amd. No.	Reaffirmed	Prepared	Issued	Dt of 1st Issue
Dt. JUN 1997	Dt.	Year	STANDARDS	STANDARDS	DEC 1986



# PLANT STANDARD

HPBP TIRUCHIRAPPALLI

BPS 41319

Rev. No. 03

PAGE 2 OF 2

## 3.2 Ordering Description

For placing indents, issuing enquiries and on purchase order, Ordering Description given below shall be followed. (Typical examples)

Hex Nut M8 to BPS : 41319-A-ASTM A194-2H for nuts with  $d \leq M16$

Hex Nut M20 to BPS : 41319-B-ASTM A194-2H for nuts with  $d > M16$  and  $d < M36 \times 3$

Hex Nut M36x3 to BPS: 41319-B-ASTM A194-2H for nuts with  $d \geq M36 \times 3$

## 4.0 ADDITIONAL INFORMATION

4.1 Copies of this standard and TDC:5:166 shall be enclosed along with the purchase order.

Figure 1 DIMENSIONS FOR HEXAGON NUTS

(All dimensions are in millimetres)

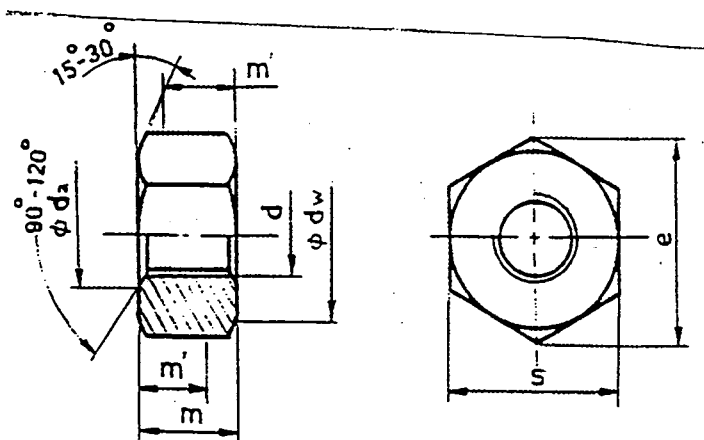

'm' = Effective gauging height

TABLE I

(All dimensions are in millimetres)

Thread Size d	d <sub>a</sub>		d <sub>w</sub>	e		m		m'	s		Weight
	Min	Max		Max	Min	Max	Min		Max	Min	
M8	8	8.75	11.6		14.38	8	7.64	6.1	13	12.73	6.0
M10	10	10.80	14.6		17.77	10	9.64	7.7	16	15.73	10.8
M12	12	13.00	16.6		20.03	12	11.57	9.3	18	17.73	16.5
M16	16	17.30	22.5		26.76	17.1	16.40	13.1	24	23.67	33.0
M20	20	21.60	27.7		32.95	20.7	19.40	15.5	30	29.16	64.5
M24	24	25.90	33.2		39.55	24.2	22.90	18.3	36	35.00	110.0
(M27)					45.20	27.6	26.30	21.0	41	40.00	166.0
M30	30	32.40	42.7		50.85	30.7	29.10	23.3	46	45.00	231.0
(M33)					55.37	33	31.40	25.1	50	49.00	299.0
M36x3	36	38.90	51.1		60.79	36.6	35.00	28.6	55	53.80	364.0
(M39x3)					66.44	39	37.40	29.9	60	58.80	485.0
(M45x3)				80.8		45	43.40	34.7	70	68.80	750.0

**NOTE :**

- Sizes in brackets are non-preferred.
- Weights are given in Kg per 1000 numbers only.



# PLANT STANDARD

HPBP TIRUCHIRAPALLI

BPS: 41408

PAGE 1 OF 3

Based on IS: 2016-1967

## PUNCHED WASHERS - TYPE A

### 1.0 SCOPE

Covers the requirements for punched washers Type A in the size range 1.8 to 78 mm.

### 2.0 SPECIFICATION AND REFERENCE STANDARDS

Dimensions and tolerances	Table 1 of this standard	
Material	Suitable Steel	
Finish	Natural finish	
Sampling and Acceptability	Indian Standard	IS: 6821 and IS: 5369
General requirements	Washers shall comply with IS: 2016 in respect of requirements not covered in this standard.	

### 2.1 Referred Standards (Only the current versions are applicable).

IS: 2016 Specification for plain washers

IS: 5369 General requirements for plain washers and lock washers

IS: 6821 Methods for sampling non-threaded fasteners

COPYRIGHT AND CONFIDENTIAL

The information on this document is the property of BHARAT HEAVY ELECTRICALS LIMITED. It must not be used directly or indirectly in any way detrimental to the interest of the company.

REVISIONS

DATE

APPROVED

STANDARDS SECTION  
ENGINEERING AND DEVELOPMENT CENTRE  
HPBP TIRUCHIRAPALLI

PREPARED

HPBP TIRUCHY

ISSUED  
STANDARDS  
ENGG

DATE

DEC 1986



# PLANT STANDARD

HPBP TIRUCHIRAPALLI

BPS: 41408

PAGE 2 OF 3

## 3.0 DESIGNATION

A punched washer to this standard for bolt/screw size M6 shall be designated as:

### 3.1 On Drawings:

- i) Material Specification column: IS: 2016-A
- ii) Description column : WASHER PNCHD A 6
- iii) Drawing Number column : 4140806000
- iv) Material code column : 4140800006

### 3.2 Ordering Description

For placing indents, issuing enquiries and on purchase orders, the ordering description given below shall be followed.

Punched Washer A 6.6\* IS: 2016 - Steel

## 4.0 ADDITIONAL INFORMATION

- 4.1 These washers can be used for Product Grade C of general purpose bolts and screws.
- \*4.2 While preparing ordering description, the actual hole size (corresponding to bolt/screw size) shall be filled in referring from Table.
- 4.3 Copies of this standard shall be enclosed alongwith the purchase orders for size 56mm and 72 mm.

COPYRIGHT AND CONFIDENTIAL

The information on this document is the property of BHARAT HEAVY ELECTRICALS LIMITED. It must not be used directly or indirectly in any way detrimental to the interest of the company.

DEC 1986

**TABLE 1 - DIMENSIONS FOR PUNCHED WASHERS**

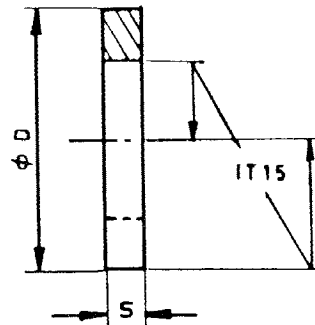
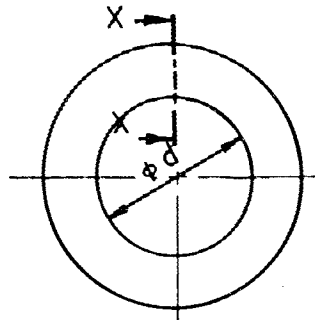

SECTION XX

(All dimensions are in millimetres)

Size d	D Nom	s Nom	For bolt/ screw size	Weight
1.8	4	0.4	M1.6	
2.4	5	0.4	M2	
3.4	7	0.5	M3	0.1
4.5	9	0.8	M4	
5.5	10	1.0	M5	
6.6	12.5	1.6	M6	1.1
9.0	17	1.6	M8	2.1
11	21	2.0	M10	3.9
14	24	2.5	M12	5.9
18	30	3.15	M16	11.1
22	37	3.15	M20	17.1
26	44	4.0	M24	31.0
(30)	50	4.0	(M27)	39.4
33	56	4.0	M30	50.4
(36)	60	5.0	(M33)	71.0
39	66	5.0	M36	87.3
(42)	72	6.0	(M39)	126.0
45	78	6.0	M42	
(48)	85	8.0	(M45)	
52	92	8.0	M48	284.0
61	105	9.0	M56	405.0
78	122	10.0	M72	543.0

**NOTE:**

1. Sizes in brackets are non-preferred.
2. Weights are given in kg per 1000 numbers only-
3. For stocked sizes refer BPScomponents booklet.



# PLANT STANDARD

HPBP TIRUCHIRAPALLI

BPS: 41704

PAGE 1 OF 4

Based on IS: 549-1974

## SPLIT PINS

### 1.0 SCOPE

Covers the requirements for Split Pins in the diameter range 0.6 to 20mm.

### 2.0 SPECIFICATION AND REFERENCE STANDARDS

Dimensions and tolerances	Table 1 of this standard	
Preferred length and size combination	Table 2 of this standard	
Material	Mild Steel Wire (Half round)	
Finish	Bright self colour finish	
Sampling and Acceptability	Indian standard	IS: 6821
	General requirements	
Pins shall comply with IS: 549 in respect of requirements not covered in this standard		

### 2.1 Referred Standards (Only the current versions are applicable)

IS: 549 Specification for Split Pins.

IS: 6821 Methods for sampling non-threaded fasteners

COPYRIGHT AND CONFIDENTIAL

The information on this document is the property of BHARAT HEAVY ELECTRICALS LIMITED. It must not be used directly or indirectly in any way detrimental to the interest of the company.

REVISIONS

DATE

APPROVED

STANDARDS SECTION  
ENGINEERING AND DEVELOPMENT CENTRE  
HPBP TIRUCHIRAPALLI

PREPARED

HPBP TIRUCHY

ISSUED

STANDARDS  
ENGG

DATE

DEC 1986



# PLANT STANDARD

HPBP TIRUCHIRAPALLI

BPS: 41704

PAGE 2 OF 4

## 3.0 DESIGNATION

A Split Pin to this standard of nominal diameter 5mm and nominal length 56mm shall be designated as:

### 3.1 On Drawings:

- i) Material Specification column: IS: 549
- ii) Description column : PIN SPLIT 5x56
- iii) Drawing Number column : 4170405056
- iv) Material Code column : 4170450056

### 3.2 Ordering Description

For placing indents, issuing enquiries and on purchase order, the Ordering Description given below shall be followed.

Split Pin 5x56 IS: 549

---

COPYRIGHT AND CONFIDENTIAL

The information on this document is the property of BHARAT HEAVY ELECTRICALS LIMITED. It must not be used directly or indirectly in any way detrimental to the interest of the company.

DEC 1986

74



# PLANT STANDARD

HPBP TIRUCHIRAPALLI

BPS: 41704

PAGE 3 OF 4

COPYRIGHT AND CONFIDENTIAL

The information on this document is the property of BHARAT HEAVY ELECTRICALS LIMITED. It must not be used directly or indirectly in any way detrimental to the interest of the company.

**TABLE 1 - DIMENSIONS FOR SPLIT PINS**  
(All dimensions in millimetres)

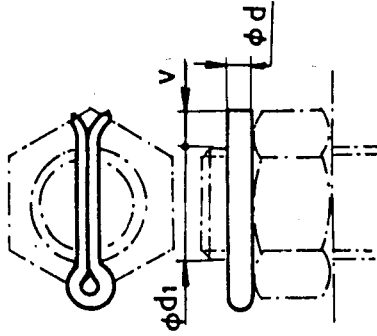
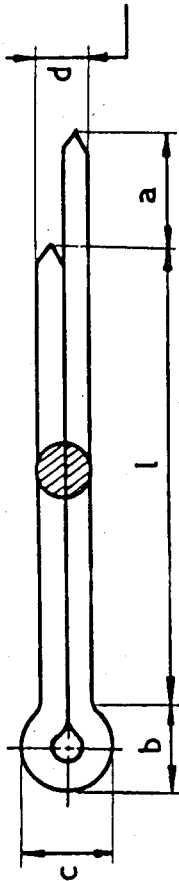

Dimensions	Nominal size	0.6	0.8	1.0	1.2	1.6	2.0	2.5	3.2	4.0	5.0	6.3	8.0	10	15	16	20
d	Max	0.5	0.7	0.9	1.0	1.4	1.8	2.3	2.9	3.7	4.6	5.9	7.5	9.5	12.4	15.4	19.3
	Min	0.4	0.6	0.8	0.9	1.3	1.7	2.1	2.7	3.5	4.4	5.7	7.3	9.3	12.1	15.1	19.0
a	Max	1.6	1.6	1.6	2.5	2.5	2.5	2.5	3.2	4.0	4.0	4.0	4.0	6.3	6.3	6.3	6.3
	≈	2.0	2.4	3.0	3.0	3.2	4.0	5.0	6.4	8.0	10	12.6	16	20	26	32	40
c	Max	1.0	1.4	1.8	2.0	2.8	3.6	4.6	5.8	7.4	9.2	11.8	15	19	24.8	30.8	38.6
	Min	0.9	1.2	1.6	1.7	2.4	3.2	4.0	5.1	6.5	8.0	10.3	13.1	16.6	21.7	27.0	33.8
Corres-ponding diameter d1	Over	--	2.5	3.5	4.5	5.5	7.0	9.0	11	14	20	27	39	56	80	120	170
	Up to	2.5	3.5	4.5	5.5	7.0	9.0	11	14	20	27	39	56	80	120	170	--
v	Over	--	2	3	4	5	6	8	9	12	17	23	29	44	69	110	160
	Up to	2	3	4	5	6	8	9	12	17	23	29	44	69	110	160	--
		3	3	4	5	5	6	6	8	8	10	12	14	16	20	25	32



# PLANT STANDARD

HPBP TIRUCHIRAPALLI

BPS: 41704

PAGE 4 OF 4

TABLE 2 - PREFERRED LENGTH-SIZE COMBINATION FOR SPLIT PINS

(All dimensions in millimetres)

1 Nom +1/2 IT 17	Nominal size																
	0.6	0.8	1.0	1.2	1.6	2.0	2.5	3.2	4.0	5.0	6.3	8.0	10	13	16	20	
4																	
5																	
6																	
8																	
10																	
12																	
14						0.4											
16																	
18																	
20																	
22									2.7								
25																	
28										5.5							
32									3.6								
36										6.5							
40									4.6		11.6						
45																	
50									5.6	8.4	13.4						
56										9.2							
63											17.2						
71																	
80																	
90																	
100																	
112																	
125																	
140																	
160																	
180																	
200																	
224																	
250																	
280																	

WEIGHTS

COPYRIGHT AND CONFIDENTIAL  
 The information on this document is the property of BHARAT HEAVY ELECTRICALS LIMITED.  
 It must not be used directly or indirectly in any way detrimental to the interest of the company.

- NOTE:**
- Weights are given in kg per 1000 numbers only
  - For stocked sizes refer BPS components booklet
  - Preferred lengths are in between the stepped bold lines

CAUTION: THIS INFORMATION ON THIS DOCUMENT IS THE PROPERTY OF BHARAT HEAVY ELECTRICALS LTD. IT MUST NOT BE USED DIRECTLY OR INDIRECTLY IN ANY WAY DETRIMENTAL TO THE INTEREST OF THE COMPANY.

REV 01	DATE 4.5.90	ALTERED: H. M. Narayan	CHECKED: [Signature]	REV 02	DATE 1.8.90	ALTERED: R. SRINIVASAN	CHECKED: [Signature]	REV 03	DATE 28.8.90	ALTERED: R. SRINIVASAN	CHECKED: [Signature]
'8g' changed to '6g' var. nos. 05 to 07 added. MATL. CODE CHANGED FOR VAR. 01 DRG RETRACED FOR ADDING VAR.				NOTE NO.04 ADDED. VAR. NO.08 & 09 ADDED.				'Z' DIMENSION CHANGED FOR VAR. NOS.01,02 & 03.			
REV 04 DATE 22.03.91 ALTERED: R. SRINIVASAN CHECKED: [Signature]				VAR NOS.02 & 05 TO 09 BIN. CODE ADDED.				REV 05 DATE 11.4.90 ALTERED: R. SRINIVASAN CHECKED: [Signature]			
M-CODE CHANGED FOR ALL VARIANTS				FOR VAR. NO. 01 BIN. CODE ADDED. INT. ALTERED FOR VAR. NOS. 01 TO 04.				REV 06 DATE 30.05.90 ALTERED: [Signature] APPROVED: [Signature]			

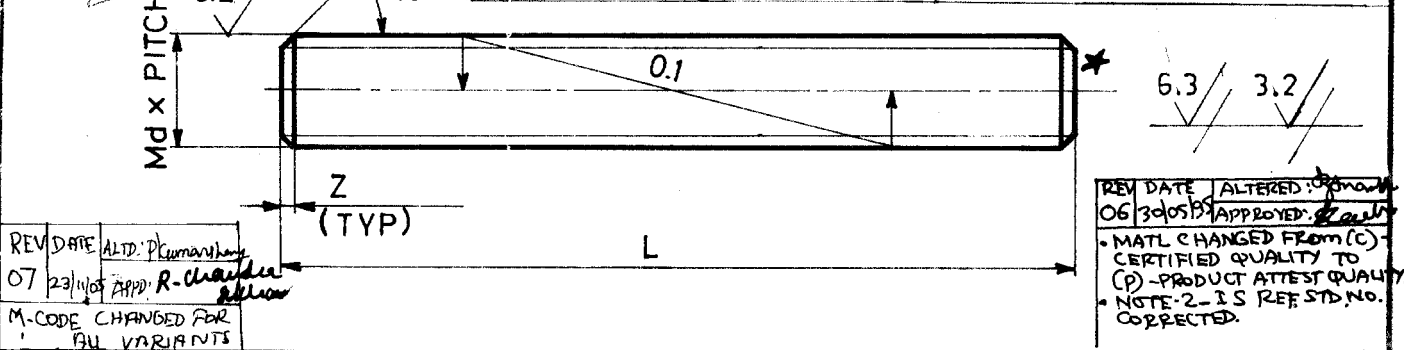

VAR. NO.	Md x PITCH	L	Z	MATL. CODE BIN. CODE	MATL. SPEC.	Wt. -Kg-	REMARKS
01	M20 x 2.5	160	2.5	15 039 086 94 822 20 16 700	SA.193 B7(P) 06	0.336	01 05
02	M24 x 3.0	230	3.0	15-039-086 94 822 24 23 700		0.690	03 04
03	M30 x 3.5	230	3.5	15-039-087 94 822 30 23 700		1.104	05
04	M36 x 4.0	290	4.0	15-039-116 94 822 36 29 700		2.001	
05	M12 x 1.75	140	1.75	15-039-115 94 822 12 14 700		0.112	07
06	M16 x 2.0	160	2.0	15-039-086 94 822 16 16 700		0.224	01 04
07	M 20x2.5	190	2.5	15-039-086 94 822 20 19 700		0.400	
08	M 20x2.5	225	2.5	15-039-086 94 822 20 23 700		0.470	
09	M 16 x 2.0	200	2.0	15-039-086 94 822 16 20 700		0.280	02

**NOTES.**

- REFER IS-1367 FOR TECHNICAL DELIVERY CONDITION FOR THREADED STEEL FASTENERS.
- REFER IS-4218 FOR ISO METRIC SCREW THREADS.
- MATERIAL IDENTIFICATION MARK 'B-7' SHOULD BE PUNCHED ON ANY ONE SIDE, AS MARKED WITH \*
- T.S. AND HARDNESS SHALL NOT BE LESS THAN  $860 \text{ N/mm}^2$  AND 250 HB.

<b>BHARAT HEAVY ELECTRICALS LTD.</b> BOILER PLANT UNIT TIRUCHIRAPALLI-620014.		DRN.	NAME	SIGN	DATE
			N. M. Nathan	H. M. Narayan	04.05.90
		CHD.	M. M. Mani		
		APPD.	S. Jayakumar	[Signature]	5/5/90
DEPT.	GRADE OF UNTOL DIM	SCALE	WEIGHT (Kg)	REF TO ASSY/OLD DRG	
CODE	C/M/F				
TITLE			CARD CODE	DRAWING No.	REV.
STUD			U 01	4-80-999-99308	



**BHARAT HEAVY ELECTRICALS LIMITED,  
PIPING CENTRE, CHENNAI - 600017.**

**QUALITY CONTROL PROCEDURE FOR  
FABRICATION OF PIPE CLAMPS**

**QCP No: 06  
REV No: 07**

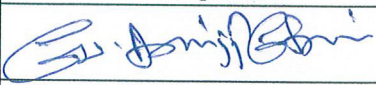
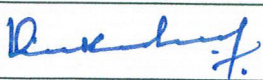
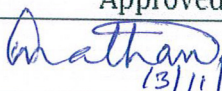
Prepared	Checked	Approved
		
Karthikeyan V (Dy.Engr/QA)	Vivekananda Yellu (Dy.Manager/QA)	Vaithianathan C (AGM/Quality)

*Proprietary Data of BHEL - For Internal Use Only*

REV No	Date	Revised Clause	Description
07	13.11.2018	All	Fabrication requirement of Gr.91/92, Stainless Steel added and full QCP revised for better clarity.

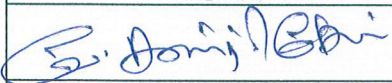
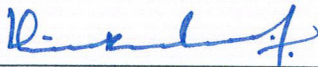
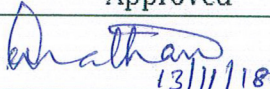
Prepared	Checked	Approved
		
Karthikeyan V (Dy.Engr/QA)	Vivekananda Yellu (Dy.Manager/QA)	Vaithianathan C (AGM/Quality)

1.0 **SCOPE:**

1.1 This Quality Control Procedure covers the quality requirements in fabrication/manufacturing of pipe clamps. (Rod type Clamp, U-Rod Clamp, Horizontal Clamps, Shock absorber Clamps, Trunnion Clamps, Riser Clamps, Bearing Clamps, Tube clips etc.,)

2.0 **MATERIALS:**

2.1 Raw Materials shall conform to the grades specified in drawings.

2.2 The Heat treatment condition of Rods & Plates shall be as follows:

Carbon Steel (P1 Group - SA105, SA515 Gr.60/70, SA 516 Gr.60/70.etc) - Normalised.

Alloy Steel (P4 Group - SA182 F11/F12, SA 387 GR 11/12, P5A Group - SA182F22, SA387 Gr 22, P15E Group - SA182 F91/92, SA387 Gr 91/92 etc.) - Normalised and Tempered.

Stainless Steel (P8Group - SA182F304/316/316L, SA240TP304/316/316L etc.)-Solution Annealed.

3.0 **FABRICATION:**

3.1 Marking & Identification:

a) Marking shall be done by scribing / light punching free of notch.

b) Specification punching and Heat no transfer to be done for Carbon steel, Alloy steel and Stainless steel plates/rods prior to cutting and recorded in cutting plan.

3.2 Cutting:

a) Plates shall be cut by shearing, saw cutting, Water jet cutting or gas cutting. Gas Cutting is PROHIBITED for Gr.91/92 materials.

b) For Plates of Gr.91/92 cutting shall be done along the grains.

c) Preheating shall be done as per TABLE - 1 during gas cutting. Gas cut edges shall be ground smooth up to depth of 6 mm minimum from cutting edge and then MPI/LPI (refer NDE clause) shall be conducted out to ensure defect free edges.

c) Rods shall be machined to the required length.

3.3 Forming:

a) All manufacturing operations shall be carried out by BHEL approved firms/vendors only.

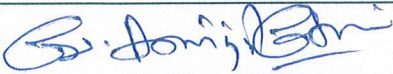
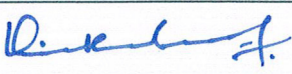
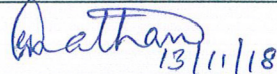
Prepared	Checked	Approved
		
Karthikeyan V (Dy.Engr/QA)	Vivekananda Yellu (Dy.Manager/QA)	Vaithianathan C (AGM/Quality)

b) Clamps shall be formed using non-striking dies (Forming by hammering is PROHIBITED).

c) Plates/Rods shall be Cold or Hot formed depending upon the radius of bend/ plate thickness / rod diameter.

d) Refer TABLE - 2 for Post Forming Heat treatment and TABLE - 4 for Rate of heating and Cooling.

e) Heat Treatment shall be done for full component.

### 3.4 Holes:

a) Holes/Slots shall be made only by drilling/boring/slotting.

b) Making holes by gas cutting is PROHIBITED.

c) Holes shall be drilled in similar to assembly condition, to avoid misalignment of holes during assembly.

### 3.5 Welding:

a) Welding shall be done using qualified WPS and welders qualified by BHEL as per AWS D1.1 or ASME Sec IX.

b) Weld edges shall be free from scale, slag, rust, moisture, grease or other foreign materials.

c) Pre heating, Electrode selection, welding parameters, post weld heating, shall be as per BHEL- Piping Centre qualified WPS.

e) Required Electrodes shall be baked in oven as per electrode manufacturer's recommendations before welding and kept in a thermal flask during welding.

### 3.6 Tolerance:

Dimensional tolerances shall be as per drawing,

### 4.0 **POST WELD HEAT TREATMENT:**

4.1 Clamps shall be Heat treated after welding as per TABLE - 3 (Post Welding) and rate of heating and cooling shall be as per TABLE - 4 as applicable.

4.2 Heat Treatment shall be done by BHEL approved Heat Treatment Agency. Heat Treatment by Resistance Heating is PROHIBITED for Gr91/92 materials.

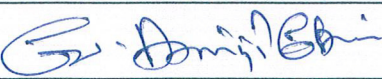
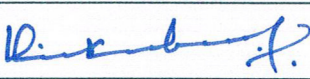
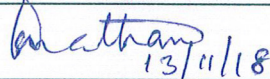
Prepared	Checked	Approved
		 13/11/18
Karthikeyan V (Dy.Engr/QA)	Vivekananda Yellu (Dy.Manager/QA)	Vaithianathan C (AGM/Quality)

4.3 Clamps made of Gr91/92 materials shall be brought to a temperature of 80~100°C after post heating and kept for minimum one hour. PWHT shall commence immediately thereafter.

5.0 **NDE - NON DESTRUCTIVE EXAMINATION:**

5.1 All NDE shall be carried out by BHEL approved agencies/Certified Level-II personnel as per SNT-TC-IA in the required NDE method.

5.2 Quantum of NDE is 10% for Carbon steels and 100% for Alloy Steels/Stainless Steel Clamps. NDE shall be done only after Heat Treatment wherever applicable.

5.3 All Clamps (Except Clamps of SS Material) shall be subjected to MPI on Weld area, Bend portion and Edges. For Gr91/92 clamps, Wet MPI method shall be used.

5.4 All Stainless Steel (SS) Clamps shall be subjected to LPI on Weld area, Bend portion and Edges.

5.5 MPI shall be as per ASME Sec V and evaluation as per ASME B31.1 CL.136.4.3. LPI shall be as per ASME Sec V and evaluation as per ASME B31.1 CL.136.4.4.

5.6 Clamps made of Gr91/92 materials shall be tested for Hardness on bend area and weld area randomly covering whole area of bending and welding. The value of hardness shall be 190 to 250 BHN.

5.7 Photo-Micrographic test shall be done for Gr91/92 clamps to conform microstructure as per ASME Material specification (Tempered Martensite). Test shall be done with photo micrographs 500X resolution minimum (actual magnification shall be indicated) and 3 replicas shall be taken in bend portion of one clamp per heat treatment batch.

6.0 **INSPECTION:**

6.1 Welding Inspection:

a) Welds shall be free from undercuts, ripples, valleys and notches.

b) Weld profile shall be dressed to suit NDE requirements.

c) Fillet weld sizes shall be checked with profile gauges.

6.2 Visual & Dimension Inspection:

a) All Clamps after Forming / Heat Treatment shall be visually inspected to ensure crack free surface.

b) All dimensions shall be as per BHEL drawing.

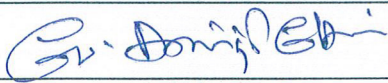
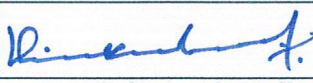
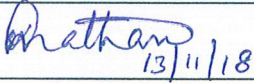
Prepared	Checked	Approved
		
Karthikeyan V (Dy.Engr/QA)	Vivekananda Yellu (Dy.Manager/QA)	Vaithianathan C (AGM/Quality)

c) Clamp profile/Final Clamp assembly shall be ensured by using layout checking method.

#### 7.0 **REPAIR:**

7.1 Defective welds shall be removed by grinding completely (ensured by NDE-LPI) and rewelded.

7.2 All the precautions, heat treatment and inspection as in the case of main weld shall be applicable for repair weld also.

#### 8.0 **IDENTIFICATION:**

8.1 Pipe clamps shall be identified as specified in P.O.

8.2 **If not specified in P.O**, pipe clamps sent to BHEL stores as **stock** shall be punched and stenciled with Firm code, Material code and Material spec alone **otherwise** Firm code, 14-digit WO/Du code, Material Spec, Quantity, Weight shall be Punched and stenciled. Punched area shall be highlighted by applying a coat of Aluminum paint or by bordering by Black paint.

Small Clamps like Tube clips, Rod clamps etc. of diameter/width less than 76.1mm and/or thickness less than 6mm, Material specification alone shall be punched, other details may be bundled and shall be stenciled by non-removable paint.

8.3 In Stainless Steel Clamps identification shall be by engraving/stenciling.

#### 9.0 **SURFACE PREPARATION, PAINTING AND COLOR CODING:**

9.1 Pipe clamps shall be Surface prepared and painted as per Project specific customer approved painting scheme.

9.2 Pipe clamps shall be painted as below **when not specified in Project specific Painting scheme / P.O/ Drawings**.

a) Surface preparation of the clamp except 91/92 and SS Clamps shall be as per SSPC-SP3 (Power tool cleaning).

b) Carbon Steel Clamps:

Shall be painted with one coat (1x30 microns) of Red-Oxide Zinc Phosphate Primer (Alkyd Base) to IS:12744 by brush/spray followed by two coats (2x20 microns) of Synthetic enamel paint to IS 2932 - SMOKE GREY COLOUR (Shade No.692 of IS 5).

c) Alloy Steel Clamps (Except 91/92 and SS Clamps):

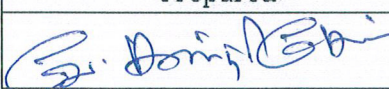
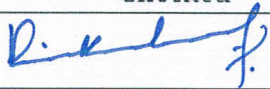
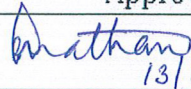
Prepared	Checked	Approved
		 13/11/18
Karthikeyan V (Dy.Engr/QA)	Vivekananda Yellu (Dy. Manager/QA)	Vaithianathan C (AGM/Quality)

Shall be painted with one coat (1x30 microns) of Red-Oxide Zinc Phosphate Primer (Alkyd Base) to IS:12744 by brush/spray followed by two coats (2x20 microns) of Synthetic enamel paint to IS 2932 - WHITE COLOUR.

d) Gr.91/92 Clamps:

Shall be surface prepared by Blast cleaning (SA2 ½) and shall be painted with two coat (2x20 microns) of Heat Resistant Aluminum paint to IS13183 Gr. I.

e) SS Clamps:

Shall be surface treated by pickling & passivation as per ASTM A380. No painting shall be done for SS clamps

9.3 Threaded portion of clamps shall be applied with rust preventive oil to avoid rusting.

9.4 Color Coding: **If not specified in P.O**, Clamps shall be Color coded as per the table below.

P. No Group	Material Specification	Color 1	Color 2	Color 3
P1	SA515 Gr.60 SA515 Gr.70/ SA105	Red Blue		
P4	SA387 Gr11 / SA182 F11 SA387 Gr12 / SA182 F12	Green Black	White Red	
P5A	SA387 Gr22 / SA182 F22	Blue	Red	
P15E	SA387 Gr91 / SA182 F91	Brown	Red	
P8	SA240 TP304 / SA182 F304 SA240 TP316 / SA182 F316 SA240 TP316L / SA182 F316L	Blue Black Blue	Yellow Green Brown	Yellow

Note: Each color band shall be of minimum 25mm, applied at visible ends preferably beyond packing.

**TABLE - 1**

***Pre Heating for Various materials***

Material	Plate Thickness (t)	Preheat Temperature
P1 Group	Below 25 mm 25 mm to 75 mm Above 75 mm	Nil 100 °C 150 °C
P4 Group	75mm and below Above 75mm	120 °C 150 °C
P5A Group	Below 13 mm 13mm to 25 mm Above 25mm	120 °C 150 °C 200 °C

Prepared	Checked	Approved
		 13/11/18
Karthikeyan V (Dy.Engr/QA)	Vivekananda Yellu (Dy.Manager/QA)	Vaithianathan C (AGM/Quality)

TABLE - 2

**Forming and Post Forming Heat Treatment****a) Forming**

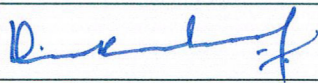
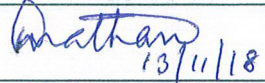

Process of Forming	Rod Dia (D) or Plate Thk (t) in mm	Radius of Bend ** (R) in mm	Forming Temp				
			Carbon Steel P1 Group	Alloy Steel P4 Group	Alloy Steel P5A Group	Alloy Steel P15E Group (Gr.91/92)	Stainless Steel P8 Group
<b>Cold Forming</b>	All	All	Room Temp	Room Temp	Room Temp	No Cold Forming	Room Temp
<b>Hot Forming - Controlled Temp (Furnace Heating)</b>	All	All	Forming Temp 620~980 °C	Forming Temp 720~1010 °C	Forming Temp 720~1010 °C	Forming Temp not less than 950 °C	Forming Temp not less than 1000 °C
<b>Hot Forming - Uncontrolled Temp</b>	All	All	Un Controlled Temp	Un Controlled Temp	Un Controlled Temp	Prohibited	Prohibited

**b) Post Forming Heat Treatment (PFHT)**

Process of Forming	Rod Dia (D)/ Plate Thk (t) in mm	Radius of Bend ** (R) in mm	Heat Treatment (PFHT) Temp with minimum Soaking time				
			Carbon Steel P1 Group	Alloy Steel P4 Group	Alloy Steel P5A Group	Alloy Steel P15E Group (Gr.91/92)	Stainless Steel P8 Group
<b>Cold Forming</b>	D ≤ 19 D > 19 t ≤ 12.7 t > 12.7	R ≥ 0.5D R > 2.5D R > t R > 2.5t	No PFHT	No PFHT	No PFHT	Prohibited	No PFHT
	D ≤ 19 D > 19 t ≤ 12.7 t > 12.7	R < 0.5D R < 2.5D R < t R < 2.5t	* SR at 595~625 °C (Min 1Hr soaking)	* SR at 650~680 °C (Min 1Hr soaking)	* SR at 680~720 °C (Min 1Hr soaking)		No PFHT
<b>Hot Forming - Controlled Temp (Furnace Heating)</b>	All	All	No PFHT	* SR at 650~680 °C (Min 1Hr soaking)	* SR at 680~720 °C (Min 1Hr soaking)	Normalise at 1040~ 1060 °C (Min 0.5Hr soaking) & Temper at 750~770 °C (Min 1Hr soaking )	Solution Anneal at 1050~ 1100 °C (Min 15 minutes soaking)
<b>Hot Forming - Uncontrolled Temp</b>	All	All	Normalise at 880~ 900 °C (Min 0.5Hr soaking)	Normalise at 920~ 950 °C (Min 0.5Hr soaking) & Temper at 650~680 °C (Min 1Hr soaking)	Normalise at 920~ 950 °C (Min 0.5Hr soaking) & Temper at 680~720 °C (Min 1Hr soaking)	Prohibited	Prohibited

\* - If welding is involved in these clamps, post forming Tempering/SR may be combined with PWHT.

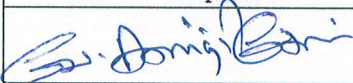
\*\* - Radius of bend to be measured at neutral axis of bend (R = smaller of R1 or R2 radius of clamps).

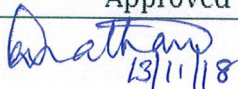
Prepared	Checked	Approved
		
Karthikeyan V (Dy.Engr/QA)	Vivekananda Yellu (Dy.Manager/QA)	Vaithianathan C (AGM/Quality)

**Table -2 Notes:**

- 1) No holding time required for forming.
- 2) Forming is not permitted on threaded areas.
- 3) Soaking or Holding time for SR/Tempering shall be calculated as 1 hour per 25mm thickness.
- 4) Soaking or Holding time for Normalising/Solution annealing shall be calculated as 0.5 hour per 25mm thickness.

**TABLE - 3*****Post Welding Heat Treatment (PWHT)***

Material Group	Thickness for Soaking Time Calculation (T)	PWHT Temperature and Min Soaking
Carbon Steel P1Group	Less than 19 mm	No HT
	19 mm and above	* Stress Reliving at 595~625°C (Min 1Hr soaking)
Alloy Steel P4Group (Gr.11/12)	All	* Stress Reliving at 650~680°C (Min 1Hr soaking)
Alloy Steel P5AGroup (Gr.22)	All	* Stress Relieving at 680~720°C (Min 1Hr soaking)
Alloy Steel P15EGroup (Gr.91/92)	All	Stress Reliving at 750~770°C (Min 1Hr soaking)
Stainless Steel P8Group (SS)	All	No HT

\* - Post forming Tempering/SR may be combined with PWHT.

**Notes:**

- 1) Soaking or Holding time shall be calculated as 1 hour per 25mm thickness (T).
- 2) T = Thickness for calculating Soaking or Holding time shall be taken as the greater value of Material Thickness or Rod Diameter or Weld Size in mm.

**TABLE - 4*****Rate of Heating and Rate of Cooling***

Material Thickness	Rate of Heating	Rate of Cooling
Upto 25mm	220°C/Hr	220°C/Hr
Over 25mm to 50mm	110°C/Hr	110°C/Hr
Over 50mm to 75mm	75°C/Hr	75°C/Hr
Over 75mm	55°C/Hr	55°C/Hr

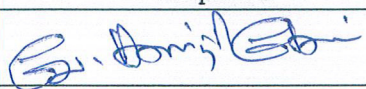
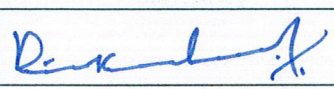
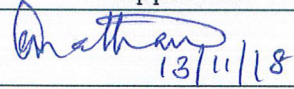
Prepared	Checked	Approved
		 13/11/18
Karthikeyan V (Dy.Engr/QA)	Vivekananda Yellu (Dy.Manager/QA)	Vaithianathan C (AGM/Quality)

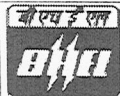

**STANDARD QUALITY PLAN FOR  
 PIPE CLAMPS**

SL. NO.	COMPONENT & OPERATIONS	CHARACTERISTICS	CLASS	TYPE OF CHECK	QUANTUM OF CHECK	REFERENCE DOCUMENT	ACCEPTANCE NORMS	FORMAT OF RECORD	AGENCY		REMARKS
									M	B	
1	2	3	4	5	6	7	8	9	10		11

<b>1.0</b>	<b>MATERIAL</b>										
1.1	Plates. SA 515 Gr 60,70. SA 387 Gr 11,22.	Chemical & Mechanical properties Soundness (UT)	Major	Review of Mill TC	100%	Material spec. as per Drg. & QCP 14	Mill TC	P	V		
			Major	Review of Mill TC	100%	ASTM A578 Level B	Mill TC	P	V		
1.2	Bars.	Chemical & Mechanical properties Soundness (UT)#	Major	Review of Mill TC	100%	Material spec. as per Drg. & QCP 14	Mill TC	P	V		
			Major	Review of Mill TC	100%	SA 388 and 3.3.4 of ASME Sec. VIII Div . 2	Mill TC	P	V		# UT only for dia. / thick ness above 50 mm.
<b>2.0</b>	<b>INPROCESS CONTROL</b>										
2.1	Process Qualification										
2.2	Welding/Welders qualification.	Procedure & Personnel qualification	Major	Review of Document	100%	ASME SEC- IX	*WPS / PQR	P	V		*Review of WPS /PQR, if the welder is already qualified by BHEL / Lloyds / SGS / BV / TUV / IRS.
3.0	Pipe Clamps – Plate Marking, Cutting & Preparation	Dimensions	Major	Measurement	100%	Drawing.	-	P	--		Otherwise the procedure & welder are to be qualified
3.1	Forming (Cold/Hot)	Time/Temp	Major	Doc. Review	100%	BHEL approved vendor forming procedure.	Log book	P	V		

**LEGEND:**

M : BHEL/BHEL Approved Vendor  
 B : BHEL/BHEL Authorized Inspection Agency  
 WPS – Welding procedure Specification  
 PQR – Procedure Qualification Report  
 P: Perform  
 V : Verification  
 W: Witness  
 IR – Inspection Report

*Suraj Kumar*

Prepared by SURAJ KUMAR  
 Engr / QA.

*Vivekananda Yellu*



Reviewed and Approved by VIVEKANANDA YELLU  
 Sr. Engr / QA



**STANDARD QUALITY PLAN FOR  
 PIPE CLAMPS**

SL. NO.	COMPONENT & OPERATIONS	CHARACTERISTICS	CLASS	TYPE OF CHECK	QUANTUM OF CHECK	REFERENCE DOCUMENT	ACCEPTANCE NORMS	FORMAT OF RECORD	AGENCY		REMARKS
									M	B	
1	2	3	4	5	6	7	8	9	10	11	

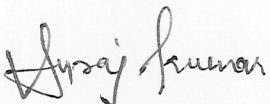
3.2	a) Heat treatment -Forming b) Heat treatment -Welding	Time/Temp Time/Temp	Major} Major}	Visual, Review of HT chart.	100% 100%	Note 1, & 2 Note 3		Chart Chart	P P	V V	
3.3	Machining, Drilling	Dimensions	Major	Measurement	100%	Drawing		Register	P	V	
3.4	NDE on a) Bend portion.	Surface Quality	Major	LPI/MPI \$	100%	ASME SEC V/ASME B 31.1 CL : 136.4.4 / 136.4.3		Report	P	W	\$ Only on the bend area
	b) Fillet Welds (RIBS)	Soundness	Major	LPI/MPI	100%	ASME SEC V/ASME B 31.1 CL : 136.4.4 / 136.4.3		Report	P	W	
3.5	PMI for Alloy Steel	Material Identification	critical	Spectrography / X-ray fluorescence	100%	Material Specification		Report	P	W	PMI – Positive Material Identification
<b>4.0</b>	<b>Final inspection.</b>										
4.1	Pipe clamp Assembly	Dimensions	Major	Measurement	100%	Drawing and Note 5 & 9		Register	P	W	
5.0	Painting and identification	Appearance ,DFT, Identification.	Major	Visual	100%	Note 6 & 7.		IR	P	W	
<b>6.0</b>	<b>Documentation</b>	QP compliance	Major	Compilation of Records.	100%	Mill TC,NDE Reports, HT Charts and inspection report.			P	V	

 Prepared by SURAJ KUMAR Engr / QA.	<b>LEGEND:</b> M : BHEL/BHEL Approved Vendor B : BHEL/BHEL Authorized Inspection Agency WPS – Welding procedure Specification PQR – Procedure Qualification Report P : Perform V : Verification W : Witness IR – Inspection Report	 Reviewed and Approved by VIVEKANANDA YELLU Sr. Engr / QA
--	--	--

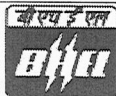

**STANDARD QUALITY PLAN FOR  
 PIPE CLAMPS**

SL. NO.	COMPONENT & OPERATIONS	CHARACTERISTICS	CLASS	TYPE OF CHECK	QUANTUM OF CHECK	REFERENCE DOCUMENT	ACCEPTANCE NORMS	FORMAT OF RECORD	AGENCY		REMARKS
									M	B	
1	2	3	4	5	6	7	8	9	10		11

**NOTE :-**

**1.0 Cold Forming**

- 1.1 Post forming Heat treatment is not required for following:
  - a) Material thickness upto 12.7 mm and inside radius (r2) 12.7 mm or more.
  - b) For materials thickness above 12.7 mm with inside radius (r2) is more than 2.5 times material thickness.
- 1.2 In other cases, carbon steel shall be heat treated at 600 – 620 Deg.C and alloy steel at 680 – 720 Deg.C with 2.5 mts/mm thickness holding ( not less than one hour ) followed by furnace cooling. Heating and cooling rate as per Note 4.0.

**2.0 Hot Forming :** Hot formed Pipe clamps shall be heat treated as below :-

- 2.1 Carbon steel (SA 515 Gr 60/70) :- Normalised at 870 – 900 Deg. C (Holding time 2.5 mts/mm minimum 1 Hr). Heating and cooling rate as per Note 4.0.
- 2.2 Alloy steel (SA 387 Gr 11/22) :- Normalised at 920 – 950 Deg. C and tempered at 680 – 720 Deg. (Holding time 2.5 mts/mm minimum 1 Hr). Heating and cooling rate as per Note 4.0.

3.0 For clamps having welding : if fillet thickness is >13mm for Alloy steel, and >19mm for carbon steel, stress relieving is applicable as indicated in Note 1.2. However PWHT may be combined with heat treatment cycle for forming.

4.0 Heating rate above 400 deg C shall be 220 deg C / hr for thickness up to 25 mm , 110 deg C / hr for thickness between 26 and 50 mm, 75 deg C / hr for thickness between 51 and 75 mm and 55 deg C / hr for thickness above 75 mm. Cooling rate up to 400 deg C shall 110 deg C for all thickness.

5.0 The following tolerances shall apply when not specified in the P.O./drawings.

- Radius of curvature - 1 , + 1mm .
- Distance between hole center - 0 , + 2 mm .
- Overall length - 0 , + 2 mm.
- Hole variation (Axis / Slot) - 0 , + 1 mm.

6.0 All pipe clamps shall be Hard punched and paint stenciled with Melt no., Matl Spec, Matl. Code and Manufacturer's seal, if clamps are sent to BHEL stores. Otherwise Work order- DU details, DU qty, Melt no, Matl. Spec. and Manufacturer's seal to be hard punched.

7.0 All pipe clamps shall be painted as below **when not specified in the P.O./Project Painting Scheme /Drawings.:-**

Carbon steel clamps:-Primer:-One coat of Redoxide zinc phosphate primer IS12744 – to 30 microns DFT  
 Finish:-Two coats of Synthetic enamel paint (long oil alkyd)to IS 2932. Smoke grey shade No 692 of IS 5- to 20 micron per coat.  
 Total DFT : Primer 30+Finish 40= 70 microns.

Alloy steel clamps:-Painting scheme as per Carbon Steel clamps , however the **Shade shall be white.**

8.0 All other components like LOAD PIN,STUD,NUT,RIBS,SPACER RING,STUD WASHER,LOAD PIN WASHER used in clamp assy shall be as per a plicable BPS/IS/ as indicated in Drawing.

9.0 All clamps shall be supplied in assembled condition along with fasteners etc., as shown in the drawing.

Prepared by SURAJ KUMAR  
 Engr / QA.

**LEGEND:**

- M : BHEL/BHEL Approved Vendor
- B : BHEL/BHEL Authorized Inspection Agency
- WPS – Welding procedure Specification
- PQR – Procedure Qualification Report
- P: Perform
- V : Verification
- W: Witness
- IR – Inspection Report

Reviewed and Approved by VIVEKANANDA YELLU  
 Sr. Engr / QA